

PLAN

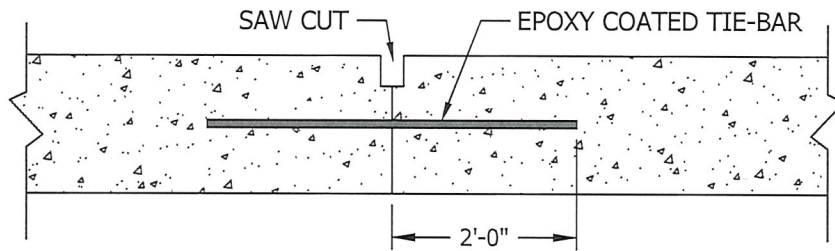

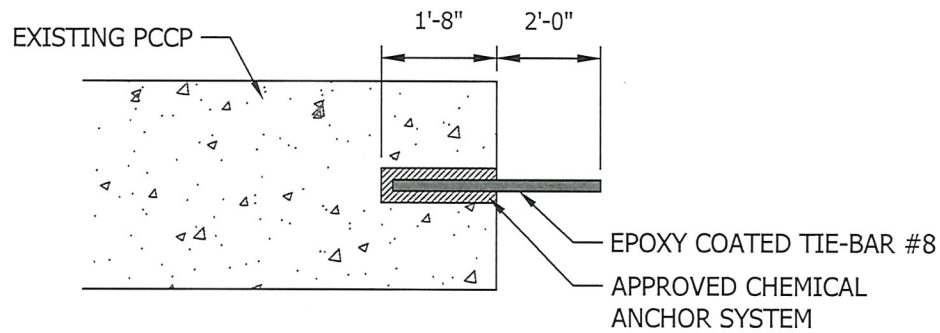

SECTION A-A



RETROFIT CONSTRUCTION TIE-BAR EMBEDMENT DETAIL

NOTES:

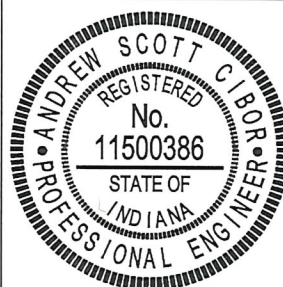
1. SAW CUTS AND JOINT SEAL MAY BE OMITTED IF PCCP IS TO BE OVERLAID.
2. MINIMUM OF 1'-6" HORIZONTAL DISTANCE BETWEEN RETROFITTED TIE BAR AND THE NEAREST D-1 CONTRACTION JOINT WITHIN THE PATCH OR THE END OF THE PATCH.
3. RETROFITTED TIE BARS ARE NOT TO BE PLACED LESS THAN 1'-6" FROM ANY TRANSVERSE JOINT OR RANDOM CRACK IN AN ADJACENT PCCP LANE OR PCCP SHOULDER.
4. A SURFACE PATCH NEEDS EXTENDED TO ADJACENT SEAM IF ANOTHER SEAM IS WITHIN 2' OF PATCH AREA.
5. SEE STANDARD DRAWING SC-6 FOR JOINT SEAL DETAIL.
6. REMOVE AND REPLACE CONCRETE TO NEAREST JOINTS.
7. ALLOW ADEQUATE CURE TIME BEFORE PERMITTING TRAFFIC ON CONCRETE
8. CONTRACTOR SHALL FOLLOW ALL MUTCD GUIDELINES.

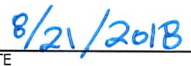
	CITY OF BLOOMINGTON
CONCRETE PAVEMENT PATCH DETAILS	
STANDARD DRAWING NO.- SC-4	
	 <small>ENGINEER</small>
	 <small>DATE</small>