

Board of Public Works Meeting

February 13, 2024



The City will offer virtual options, including CATS public access television (live and tape-delayed) and

Public comments and questions will be encouraged via Zoom or bloomington.in.gov rather than in person

The City is committed to providing equal access to information. However, despite our efforts, at times, portions of our board and commission packets are not accessible for some individuals. If you encounter difficulties accessing material in this packet, please contact April Rosenberger, Public Works Departmental Accessibility contact at april.rosenberger@bloomington.in.gov or 812.349.3411 and provide your name, contact information, and a link to or description of the document or web page you are having problems with.

AGENDA
BOARD OF PUBLIC WORKS
February 13, 2024

A Regular Meeting of the Board of Public Work will be held Tuesday, **February 13, 2024 at 5:30 p.m.** in the Council Chambers (Rm #115) of City Hall at the Showers Building, 401 N. Morton Street, Bloomington, Indiana and via Zoom by using the following link

<https://bloomington.zoom.us/j/81905668540?pwd=ncW9KCRFIfFsRajcULubV0FEuzy4Rn.1>

Meeting ID: 819 0566 8540 Passcode: 960413

I. MESSAGES FROM BOARD MEMBERS

II. PETITIONS AND REMONSTRANCES

III. TITLE VI ABATEMENT

1. Request for Abatement at 1919 N. College

IV. CONSENT AGENDA

1. Approval of Minutes; September 26, 2023
2. Approval of Minutes; October 10, 2023
3. Approval of Minutes; October 24, 2023
4. Approval of Minutes; November 08, 2023
5. Approval of Minutes; November 21, 2023
6. Resolution 2024-003; Declaration of ITS Surplus for Recycling
7. Resolution 2024-004; Declaration of ITS Surplus for Donation
8. Resolution 2024-005; Declaration of ITS Surplus for Donation
9. Precision Concrete 2024 Service Agreement
10. Renewal #2 with Groomer Construction for Sidewalk Assistance Program
11. Renewal #2 with Groomer Construction for Sidewalk Services
12. Approval of Payroll

V. NEW BUSINESS

1. Lane and Sidewalk Closure Requests from AEG
2. Lane and Sidewalk Closures Request from Lineal Contracting
3. Sidewalk Closure Request on E 3rd St from Strauser Construction (March 9- March 16, 2024)
4. Sidewalk Closure and Metered Parking Reservation Request from Gilliatte General Contractors (February 14-28, 2024)
5. Lane Closure Request from City of Bloomington Utilities
6. Contract with Applied Engineering Services for Walnut and Morton St. Garages

VI. STAFF REPORTS & OTHER BUSINESS

VII. APPROVAL OF CLAIMS

VIII. ADJOURNMENT

The City is committed to providing equal access to information. However, despite our efforts, at times, portions of our board and commission packets are not accessible for some individuals. If you encounter difficulties accessing material in this packet, please contact April Rosenberger, Public Works Departmental Accessibility contact at april.rosenberger@bloomington.in.gov or 812.349.3411 and provide your name, contact information, and a link to or description of the document or web page you are having problems with.

The City offers virtual options, including CATS public access television (live and tape- delayed). Comments and questions will be encouraged via Zoom or bloomington.in.gov rather than in person.

Auxiliary aids for people with disabilities are available upon request with adequate notice. Please call 812.349.3411 or email public.works@bloomington.in.gov

Staff Report

To: Board of Public Works

From: Rebecca Davis

Date: February 6, 2024

Re: Request to abate property at 1919 N. College Ave., Bloomington, Indiana

Attachments:

1. Notices of Violation issued 11/03/2023, 11/17/2023, 11/30/2023, 12/15/2023, 01/26/2024, and 02/01/2024.
2. Photograph(s) of the property
3. GIS property information
4. Proof Of Service Documents
5. Proposed Order for Abatement

Facts:

1. Bloomington Municipal Code § 6.06.020 makes it unlawful for “any person to throw, place, or scatter any garbage, rubbish, trash, or other refuse over or upon any premises, street, alley, either public or private, or to suffer or permit any garbage, rubbish, trash or other refuse to be placed or deposited on the premises owned, occupied or controlled by such person either with or without the intent to later remove, cover, or burn it.”
2. On November 3, 2023, a Neighborhood Compliance Office inspected the property located at 1919 N. College Ave., Bloomington, Indiana (hereinafter, the “Property”) for trash and litter on the Property and issued a Notice of Violation for garbage, rubbish, trash or other refuse in violation of BMC § 6.06.020.
3. On November 17, 2023; November 30, 2023; December 15, 2023; January 26, 2024; and February 1, 2024, a Neighborhood Compliance Officer re-inspected the Property and issued additional Notices of Violation for the trash and litter on the Property in violation of BMC § 6.06.020 (hereinafter, the November 3 Notice of Violation and the November 17, November 30, December 15, January 26, and February 1, 2024 Notices of Violation are collectively the “NOVs”).
4. The Steak and Shake, as an ongoing business concern, has been closed for business for several years and the building is unoccupied.
5. Each of the NOVs were issued to the owner of the property, Steak and Shake Operations, Inc. (hereinafter, the “Owner”), by mailing the NOV’s to the Owner’s last known address of: P.O. Box 460169 Houston, TX 77056 C/O Ryan, LLC, in accordance with BMC § 6.06.070(b).
6. The violations have not been corrected and the NOVs were not appealed.
7. The Notice of Request to Abate was served on the Owner of the Property by certified mail, and then by regular mail, both to the last known address of the Owner as identified above, all in accordance with BMC § 6.06.080(b).

Status of the Property and Reason for Abatement:

The Property remains out of compliance. Garbage remains thrown, placed and scattered on the Property. The Property needs to be abated to eliminate the violation and public nuisance.

Staff Recommendation:

Staff recommends that the Property be abated as soon as reasonably possible.



Notice of Violation

Housing & Neighborhood
Development Department (HAND)
P.O. Box 100
401 N. Morton Street
Bloomington, IN 47402
www.bloomington.in.gov/hand/

Date 1/03/2023 Time 10:13 AM Address/location 1919 N COLLEGE AVE 47404

Issued by: 219

BMC 6.04.110 Carts, containers and other articles to be picked up shall not be placed upon the street or sidewalk *so as to be visible* from the street more than twenty-four hours prior to the time when such solid waste, recycling or yard waste is to be collected. Carts and containers shall be removed from the street or sidewalk on the same day as the collection is made.

Fine Due: \$15.00 Warning (No fine due at this time) Ticket# _____

NOTE: Immediate compliance required in order to avoid additional violations/fines assessed at \$15.00/day per BMC 6.04.100(c).

BMC 6.06.020 It is unlawful for any person to throw, place, or scatter any garbage, recyclable materials or yard waste over or upon any premises, street, alley, either public or private, or to suffer or permit any garbage, recyclable materials or yard waste to be placed or deposited on the premises owned, occupied or controlled by such person either with or without the intent to remove, cover or burn it.

Fine Due: \$50 \$100 \$150 Warning (No fine due at this time) Ticket# 62023-11-1872

NOTE: Immediate compliance required in order to avoid additional violations/fines assessed at \$50.00, \$100, or \$150/day per BMC 6.06.070(c).

BMC 6.06.050 It is unlawful for the owner of any lot or tract of ground within the city to allow it to become overgrown with weeds, grass, or noxious plants beyond the height of 8 inches or to such extent that the growth is detrimental to the public health and constitutes a nuisance.

Fine Due: \$50 \$100 \$150 Warning (No fine due at this time) Ticket# _____

NOTE: Immediate compliance required in order to avoid additional violations/fines assessed at \$50.00, \$100, or \$150/day per BMC 6.06.070(c).

Comments: TRASH INSIDE OLD DUMPSTER LOCATION

1. Fine must be paid within 2 weeks from date of issuance of the Notice of Violation (NOV) to avoid this matter being forwarded to the City's Legal Department for further enforcement action. This NOV must be returned with payment. **You may pay in person or mail payment to the address listed above. Please make check/money order payable to "The City of Bloomington."** All fines listed above may be contested in the Monroe County Circuit Courts.
2. Fines shall not attach to non-possessory residential rental property owner(s) for a period of seven (7) days provided HAND is presented with a true and exact copy of any and all leases in effect during the time period covered by the NOV (per occurrence), at which time said tenant(s) shall be held responsible for fines due. A non-possessory residential rental property owner is the owner of record, but one that is not a resident of said property. Property owner(s) shall otherwise be held responsible for fines if a lease is not presented in the time period indicated.
3. The City may seek action by its Board of Public Works or the Monroe County Circuit Courts in assessing fines, ordering remediation of the property (the City has the authority to bring the property into compliance itself or the City may hire a private third-party contractor to bring the property into compliance) and/or assessing costs associated with clean-up of the property, and pursuing any other remedies available by law, including but not limited to injunctive relief. If the City or their designee, with permission from the City of Bloomington Board of Public Works, enters the property and abates the violation the owner shall be responsible for reimbursing the City for the abatement and all associated cost.
4. This NOV may be appealed to the City's Board of Public Works, provided a written appeal is filed with the Board, via the City's Public Works Department, within seven days of the date of issuance of this NOV.

Owner Name STEAK N SHAKE OPERATIONS INC
 Address c/o RYAN, LLC P.O. Box 460169
 City HOUSTEN State TX
 Zip Code 77056

Agent Name _____
 Address _____
 City _____ State _____
 Zip Code _____

BPW: _____

Mail Copies To: Resident: _____ Owner: X Agent: _____



Notice of Violation

Housing & Neighborhood Development Department (HAND)
P.O. Box 100
401 N. Morton Street
Bloomington, IN 47402
www.bloomington.in.gov/hand/

Date 11/16/2023 Time 4:41 PM Address/location 1919 N. COLLEGE AVE 47404

Issued by: 219

BMC 6.04.110 Carts, containers and other articles to be picked up shall not be placed upon the street or sidewalk *so as to be visible* from the street more than twenty-four hours prior to the time when such solid waste, recycling or yard waste is to be collected. Carts and containers shall be removed from the street or sidewalk on the same day as the collection is made.

Fine Due: \$15.00 Warning (No fine due at this time) Ticket# _____

NOTE: Immediate compliance required in order to avoid additional violations/fines assessed at \$15.00/day per BMC 6.04.100(c).

BMC 6.06.020 It is unlawful for any person to throw, place, or scatter any garbage, recyclable materials or yard waste over or upon any premises, street, alley, either public or private, or to suffer or permit any garbage, recyclable materials or yard waste to be placed or deposited on the premises owned, occupied or controlled by such person either with or without the intent to remove, cover or burn it.

Fine Due: ~~\$50~~ \$100 \$150 Warning (No fine due at this time) Ticket# 62023-11-1893

NOTE: Immediate compliance required in order to avoid additional violations/fines assessed at \$50.00, \$100, or \$150/day per BMC 6.06.070(c).

BMC 6.06.050 It is unlawful for the owner of any lot or tract of ground within the city to allow it to become overgrown with weeds, grass, or noxious plants beyond the height of 8 inches or to such extent that the growth is detrimental to the public health and constitutes a nuisance.

Fine Due: \$50 \$100 \$150 Warning (No fine due at this time) Ticket# _____

NOTE: Immediate compliance required in order to avoid additional violations/fines assessed at \$50.00, \$100, or \$150/day per BMC 6.06.070(c).

Comments: GARBAGE IN DUMPSTER FENCE

1. Fine must be paid within 2 weeks from date of issuance of the Notice of Violation (NOV) to avoid this matter being forwarded to the City's Legal Department for further enforcement action. This NOV must be returned with payment. **You may pay in person or mail payment to the address listed above. Please make check/money order payable to "The City of Bloomington."** All fines listed above may be contested in the Monroe County Circuit Courts.
2. Fines shall not attach to non-possessory residential rental property owner(s) for a period of seven (7) days provided HAND is presented with a true and exact copy of any and all leases in effect during the time period covered by the NOV (per occurrence), at which time said tenant(s) shall be held responsible for fines due. A non-possessory residential rental property owner is the owner of record, but one that is not a resident of said property. Property owner(s) shall otherwise be held responsible for fines if a lease is not presented in the time period indicated.
3. The City may seek action by its Board of Public Works or the Monroe County Circuit Courts in assessing fines, ordering remediation of the property (the City has the authority to bring the property into compliance itself or the City may hire a private third-party contractor to bring the property into compliance) and/or assessing costs associated with clean-up of the property, and pursuing any other remedies available by law, including but not limited to injunctive relief. If the City or their designee, with permission from the City of Bloomington Board of Public Works, enters the property and abates the violation the owner shall be responsible for reimbursing the City for the abatement and all associated cost.
4. This NOV may be appealed to the City's Board of Public Works, provided a written appeal is filed with the Board, via the City's Public Works Department, within seven days of the date of issuance of this NOV.

Owner Name STEVEN SHAKE OPERATIONS LLC
 Address 90 RYAN LLC P.O. BOX 460169
 City HOUSTON State TX
 Zip Code 77056

Agent Name _____
 Address _____
 City _____ State _____
 Zip Code _____

BPW: _____

Mail Copies To: Resident: _____ Owner: Agent:



Notice of Violation

**Housing & Neighborhood
Development Department (HAND)**
P.O. Box 100
401 N. Morton Street
Bloomington, IN 47402
www.bloomington.in.gov/hand/

Date 11/30/23 Time 3:19 PM Address/location 1919 N COLLEGE AVE 47404

Issued by: 219

BMC 6.04.110 Carts, containers and other articles to be picked up shall not be placed upon the street or sidewalk *so as to be visible* from the street more than twenty-four hours prior to the time when such solid waste, recycling or yard waste is to be collected. Carts and containers shall be removed from the street or sidewalk on the same day as the collection is made.

Fine Due: \$15.00 **Warning (No fine due at this time)** Ticket# _____

NOTE: Immediate compliance required in order to avoid additional violations/fines assessed at **\$15.00/day** per BMC 6.04.100(c).

BMC 6.06.020 It is unlawful for any person to throw, place, or scatter any garbage, recyclable materials or yard waste over or upon any premises, street, alley, either public or private, or to suffer or permit any garbage, recyclable materials or yard waste to be placed or deposited on the premises owned, occupied or controlled by such person either with or without the intent to remove, cover or burn it.

Fine Due: \$50 \$100 \$150 **Warning (No fine due at this time)** Ticket# 62023-11-1930

NOTE: Immediate compliance required in order to avoid additional violations/fines assessed at **\$50.00, \$100, or \$150/day** per BMC 6.06.070(c).

BMC 6.06.050 It is unlawful for the owner of any lot or tract of ground within the city to allow it to become overgrown with weeds, grass, or noxious plants beyond the height of 8 inches or to such extent that the growth is detrimental to the public health and constitutes a nuisance.

Fine Due: \$50 \$100 \$150 **Warning (No fine due at this time)** Ticket# _____

NOTE: Immediate compliance required in order to avoid additional violations/fines assessed at **\$50.00, \$100, or \$150/day** per BMC 6.06.070(c).

Comments: CLEAN OUT DUMPSTER AREA.

1. Fine must be paid within 2 weeks from date of issuance of the Notice of Violation (NOV) to avoid this matter being forwarded to the City's Legal Department for further enforcement action. This NOV must be returned with payment. **You may pay in person or mail payment to the address listed above. Please make check/money order payable to "The City of Bloomington."** All fines listed above may be contested in the Monroe County Circuit Courts.
2. Fines shall not attach to non-possessory residential rental property owner(s) for a period of seven (7) days provided HAND is presented with a true and exact copy of any and all leases in effect during the time period covered by the NOV (per occurrence), at which time said tenant(s) shall be held responsible for fines due. A non-possessory residential rental property owner is the owner of record, but one that is not a resident of said property. Property owner(s) shall otherwise be held responsible for fines if a lease is not presented in the time period indicated.
3. The City may seek action by its Board of Public Works or the Monroe County Circuit Courts in assessing fines, ordering remediation of the property (the City has the authority to bring the property into compliance itself or the City may hire a private third-party contractor to bring the property into compliance) and/or assessing costs associated with clean-up of the property, and pursuing any other remedies available by law, including but not limited to injunctive relief. If the City or their designee, with permission from the City of Bloomington Board of Public Works, enters the property and abates the violation the owner shall be responsible for reimbursing the City for the abatement and all associated cost.
4. This NOV may be appealed to the City's Board of Public Works, provided a written appeal is filed with the Board, via the City's Public Works Department, within seven days of the date of issuance of this NOV.

Owner Name STEAK N GITAKE OPERATIONS INC
90 RYAN, LLC
 Address P.O. BOX 460169
 City HOUSTON State TX
 Zip Code 77056

Agent Name _____
 Address _____
 City _____ State _____
 Zip Code _____

BPW: _____

Mail Copies To: Resident: _____ Owner: _____ Agent: _____

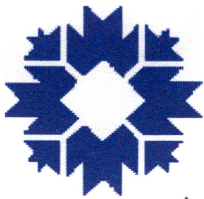

Notice of Violation

**Housing & Neighborhood
Development Department (HAND)**
P.O. Box 100
401 N. Morton Street
Bloomington, IN 47402
www.bloomington.in.gov/hand/

Date 12/15/23 Time 8:55 am Address/location 1919 N COLLEGE AVE

Issued by: 219

BMC 6.04.110 Carts, containers and other articles to be picked up shall not be placed upon the street or sidewalk *so as to be visible* from the street more than twenty-four hours prior to the time when such solid waste, recycling or yard waste is to be collected. Carts and containers shall be removed from the street or sidewalk on the same day as the collection is made.

Fine Due: \$15.00 **Warning (No fine due at this time)** Ticket# _____

NOTE: Immediate compliance required in order to avoid additional violations/fines assessed at \$15.00/day per BMC 6.04.100(c).

BMC 6.06.020 It is unlawful for any person to throw, place, or scatter any garbage, recyclable materials or yard waste over or upon any premises, street, alley, either public or private, or to suffer or permit any garbage, recyclable materials or yard waste to be placed or deposited on the premises owned, occupied or controlled by such person either with or without the intent to remove, cover or burn it.

Fine Due: \$50 \$100 \$150 **Warning (No fine due at this time)** Ticket# 62023-12-1979

NOTE: Immediate compliance required in order to avoid additional violations/fines assessed at \$50.00, \$100, or \$150/day per BMC 6.06.070(c).

BMC 6.06.050 It is unlawful for the owner of any lot or tract of ground within the city to allow it to become overgrown with weeds, grass, or noxious plants beyond the height of 8 inches or to such extent that the growth is detrimental to the public health and constitutes a nuisance.

Fine Due: \$50 \$100 \$150 **Warning (No fine due at this time)** Ticket# _____

NOTE: Immediate compliance required in order to avoid additional violations/fines assessed at \$50.00, \$100, or \$150/day per BMC 6.06.070(c).

Comments: NEXT TICKET TO BOARD OF PUBLIC WORKS FOR ABATEMENT.

REMOVE ALL GARBAGE FROM DUMPSTER AREA.

1. Fine must be paid within 2 weeks from date of issuance of the Notice of Violation (NOV) to avoid this matter being forwarded to the City's Legal Department for further enforcement action. This NOV must be returned with payment. **You may pay in person or mail payment to the address listed above. Please make check/money order payable to "The City of Bloomington."** All fines listed above may be contested in the Monroe County Circuit Courts.
2. Fines shall not attach to non-possessory residential rental property owner(s) for a period of seven (7) days provided HAND is presented with a true and exact copy of any and all leases in effect during the time period covered by the NOV (per occurrence), at which time said tenant(s) shall be held responsible for fines due. A non-possessory residential rental property owner is the owner of record, but one that is not a resident of said property. Property owner(s) shall otherwise be held responsible for fines if a lease is not presented in the time period indicated.
3. The City may seek action by its Board of Public Works or the Monroe County Circuit Courts in assessing fines, ordering remediation of the property (the City has the authority to bring the property into compliance itself or the City may hire a private third-party contractor to bring the property into compliance) and/or assessing costs associated with clean-up of the property, and pursuing any other remedies available by law, including but not limited to injunctive relief. If the City or their designee, with permission from the City of Bloomington Board of Public Works, enters the property and abates the violation the owner shall be responsible for reimbursing the City for the abatement and all associated cost.
4. This NOV may be appealed to the City's Board of Public Works, provided a written appeal is filed with the Board, via the City's Public Works Department, within seven days of the date of issuance of this NOV.

Owner Name STEAK N SHAKE OPERATIONS INC
c/o RYAN, LLC
 Address P.O. BOX 460169
 City HOUSTON State TX
 Zip Code 77056

Agent Name _____
 Address _____
 City _____ State _____
 Zip Code _____

BPW: _____

Mail Copies To: Resident: _____ Owner: _____ Agent: _____



Notice of Violation

Housing & Neighborhood
Development Department (HAND)
P.O. Box 100
401 N. Morton Street
Bloomington, IN 47402
www.bloomington.in.gov/hand/

Date 1/26/24 Time 8:53 Am Address/location 1919 N COLLEGE AVE 47404

Issued by: 219

BMC 6.04.110 Carts, containers and other articles to be picked up shall not be placed upon the street or sidewalk *so as to be visible* from the street more than twenty-four hours prior to the time when such solid waste, recycling or yard waste is to be collected. Carts and containers shall be removed from the street or sidewalk on the same day as the collection is made.

Fine Due: \$15.00 Warning (No fine due at this time) Ticket# _____

NOTE: Immediate compliance required in order to avoid additional violations/fines assessed at \$15.00/day per BMC 6.04.100(c).

BMC 6.06.020 It is unlawful for any person to throw, place, or scatter any garbage, recyclable materials or yard waste over or upon any premises, street, alley, either public or private, or to suffer or permit any garbage, recyclable materials or yard waste to be placed or deposited on the premises owned, occupied or controlled by such person either with or without the intent to remove, cover or burn it.

Fine Due: \$50 \$100 \$150 Warning (No fine due at this time) Ticket# 62024-01-2102

NOTE: Immediate compliance required in order to avoid additional violations/fines assessed at \$50.00, \$100, or \$150/day per BMC 6.06.070(c).

BMC 6.06.050 It is unlawful for the owner of any lot or tract of ground within the city to allow it to become overgrown with weeds, grass, or noxious plants beyond the height of 8 inches or to such extent that the growth is detrimental to the public health and constitutes a nuisance.

Fine Due: \$50 \$100 \$150 Warning (No fine due at this time) Ticket# _____

NOTE: Immediate compliance required in order to avoid additional violations/fines assessed at \$50.00, \$100, or \$150/day per BMC 6.06.070(c).

Comments: _____

1. Fine must be paid within 2 weeks from date of issuance of the Notice of Violation (NOV) to avoid this matter being forwarded to the City's Legal Department for further enforcement action. This NOV must be returned with payment. **You may pay in person or mail payment to the address listed above. Please make check/money order payable to "The City of Bloomington."** All fines listed above may be contested in the Monroe County Circuit Courts.
2. Fines shall not attach to non-possessory residential rental property owner(s) for a period of seven (7) days provided HAND is presented with a true and exact copy of any and all leases in effect during the time period covered by the NOV (per occurrence), at which time said tenant(s) shall be held responsible for fines due. A non-possessory residential rental property owner is the owner of record, but one that is not a resident of said property. Property owner(s) shall otherwise be held responsible for fines if a lease is not presented in the time period indicated.
3. The City may seek action by its Board of Public Works or the Monroe County Circuit Courts in assessing fines, ordering remediation of the property (the City has the authority to bring the property into compliance itself or the City may hire a private third-party contractor to bring the property into compliance) and/or assessing costs associated with clean-up of the property, and pursuing any other remedies available by law, including but not limited to injunctive relief. If the City or their designee, with permission from the City of Bloomington Board of Public Works, enters the property and abates the violation the owner shall be responsible for reimbursing the City for the abatement and all associated cost.
4. This NOV may be appealed to the City's Board of Public Works, provided a written appeal is filed with the Board, via the City's Public Works Department, within seven days of the date of issuance of this NOV.

Owner Name STEAK N SHAKE OPERATIONS INC / RYAN
 Address P.O. BOX 460169
 City HOUSTON State TX
 Zip Code 77056

Agent Name _____
 Address _____
 City _____ State _____
 Zip Code _____

BPW: _____

Mail Copies To: Resident: _____ Owner: Agent: _____



Notice of Violation

**Housing & Neighborhood
Development Department (HAND)**
P.O. Box 100
401 N. Morton Street
Bloomington, IN 47402
www.bloomington.in.gov/hand/

Date 2/1/2024 Time 2:25 pm Address/location 1919 N. COLLEGE AVE 47404

Issued by: 219

BMC 6.04.110 Carts, containers and other articles to be picked up shall not be placed upon the street or sidewalk *so as to be visible* from the street more than twenty-four hours prior to the time when such solid waste, recycling or yard waste is to be collected. Carts and containers shall be removed from the street or sidewalk on the same day as the collection is made.

Fine Due: \$15.00 **Warning (No fine due at this time)** Ticket# _____

NOTE: Immediate compliance required in order to avoid additional violations/fines assessed at \$15.00/day per BMC 6.04.100(c).

BMC 6.06.020 It is unlawful for any person to throw, place, or scatter any garbage, recyclable materials or yard waste over or upon any premises, street, alley, either public or private, or to suffer or permit any garbage, recyclable materials or yard waste to be placed or deposited on the premises owned, occupied or controlled by such person either with or without the intent to remove, cover or burn it.

Fine Due: \$50 \$100 \$150 **Warning (No fine due at this time)** Ticket# 62024-02-2106

NOTE: Immediate compliance required in order to avoid additional violations/fines assessed at \$50.00, \$100, or \$150/day per BMC 6.06.070(c).

BMC 6.06.050 It is unlawful for the owner of any lot or tract of ground within the city to allow it to become overgrown with weeds, grass, or noxious plants beyond the height of 8 inches or to such extent that the growth is detrimental to the public health and constitutes a nuisance.

Fine Due: \$50 \$100 \$150 **Warning (No fine due at this time)** Ticket# _____

NOTE: Immediate compliance required in order to avoid additional violations/fines assessed at \$50.00, \$100, or \$150/day per BMC 6.06.070(c).

Comments: GOING TO BOARD OF PUBLIC WORKS TO REQUEST PERMISSION TO ABATE.

1. Fine must be paid within 2 weeks from date of issuance of the Notice of Violation (NOV) to avoid this matter being forwarded to the City's Legal Department for further enforcement action. This NOV must be returned with payment. **You may pay in person or mail payment to the address listed above. Please make check/money order payable to "The City of Bloomington."** All fines listed above may be contested in the Monroe County Circuit Courts.
2. Fines shall not attach to non-possessory residential rental property owner(s) for a period of seven (7) days provided HAND is presented with a true and exact copy of any and all leases in effect during the time period covered by the NOV (per occurrence), at which time said tenant(s) shall be held responsible for fines due. A non-possessory residential rental property owner is the owner of record, but one that is not a resident of said property. Property owner(s) shall otherwise be held responsible for fines if a lease is not presented in the time period indicated.
3. The City may seek action by its Board of Public Works or the Monroe County Circuit Courts in assessing fines, ordering remediation of the property (the City has the authority to bring the property into compliance itself or the City may hire a private third-party contractor to bring the property into compliance) and/or assessing costs associated with clean-up of the property, and pursuing any other remedies available by law, including but not limited to injunctive relief. If the City or their designee, with permission from the City of Bloomington Board of Public Works, enters the property and abates the violation the owner shall be responsible for reimbursing the City for the abatement and all associated cost.
4. This NOV may be appealed to the City's Board of Public Works, provided a written appeal is filed with the Board, via the City's Public Works Department, within seven days of the date of issuance of this NOV.

Owner Name STEAK N SHAKE OPERATIONS INC
 Address PO Box 460169 C/O RYAN, LLC
 City HOUSTON State TX
 Zip Code 77056

Agent Name _____
 Address _____
 City _____ State _____
 Zip Code _____

BPW: 02/13/2024

Mail Copies To: Resident: _____ Owner: _____ Agent: _____



**City of Bloomington
Housing and Neighborhood Development**

NOTICE OF REQUEST FOR ABATEMENT

To: Steak N Shake Operations Inc. c/o Ryan (“Property Owner”)

The City of Bloomington Housing and Neighborhood Development (“HAND”) Department has requested that the Board of Public Works issue an order to abate the ordinance violation(s) noted on the attached ticket(s) at the property located at **1919 N College AVE, Bloomington 47404**, under parcel number 53-05-28-300-136.000-005 and whose legal description is 013-26360-00 PT NW SW 28-9-1W .61A; PLAT 42 (Hereinafter the “Property”).

If the Board of Public Works grants HAND’s request, then HAND or its third party contractor will enter into and onto the Property and abate the violation(s). The Property Owner shall be responsible for reimbursing the City for the abatement and all associated costs. If the Property Owner fails to reimburse the city for any and all costs associated with an abatement of his property, said costs shall be filed with the county auditor and placed on the tax duplicate for the property at issue; said costs being collected as taxes are collected.

If you do not immediately remedy the ongoing ordinance violations on your property, HAND will seek authorization for abatement of said violation(s) at the Board of Public Works meeting to be held at **5:30 P.M. Tuesday February 13, 2024 via ZOOM meetings and in person in the Council Chamber of City Hall, 401 N. Morton Street, Bloomington, Indiana 47404. You must contact the Office of Public Works at 812-349-3410 or email at public.works@bloomington.in.gov for further information.**

The Property Owner is entitled to present arguments and evidence in defense of this request for abatement.

Fines are not appealed at this meeting

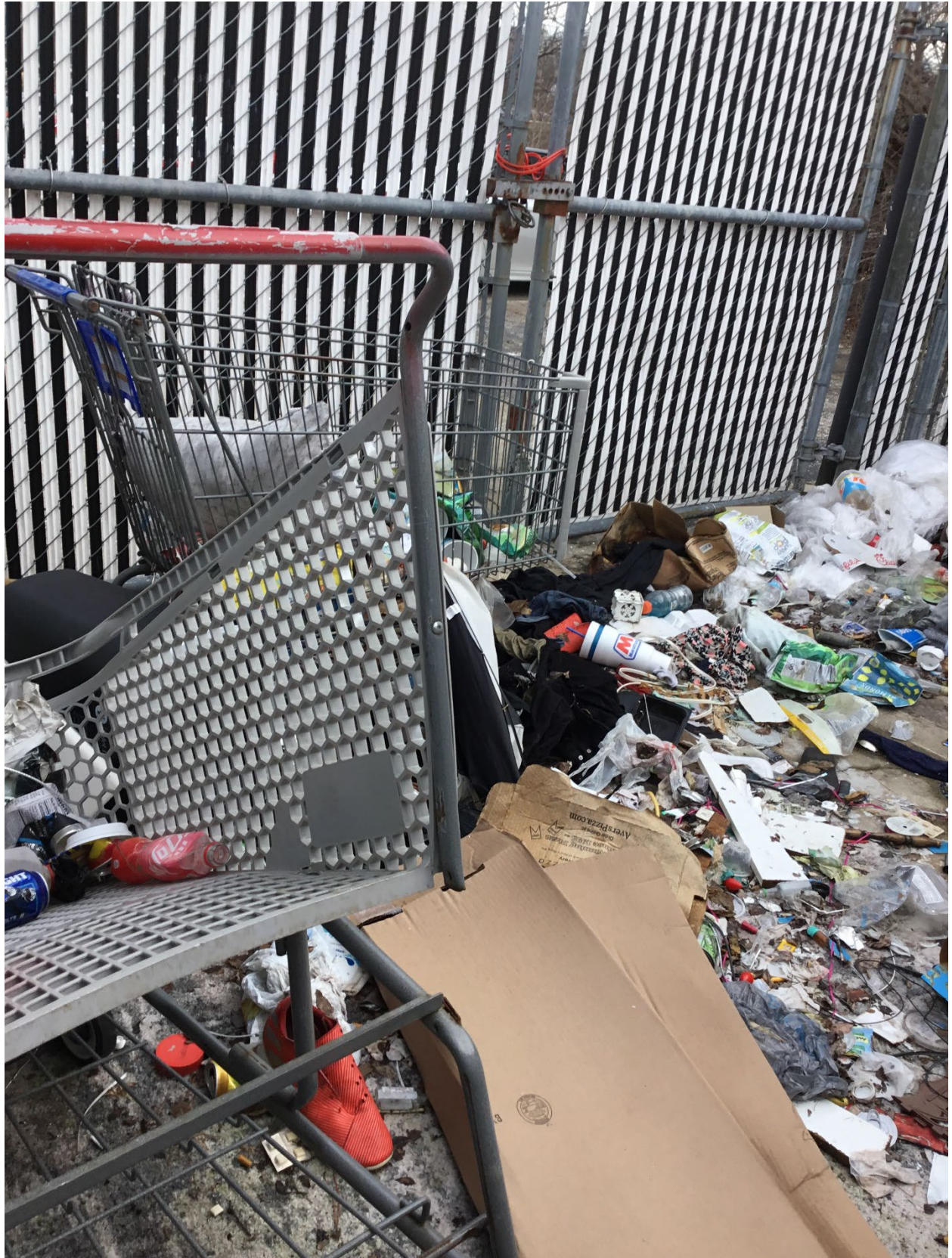



Monroe County, IN

1919 N College AVE, Bloomington, IN 47404
53-05-28-300-136.000-005

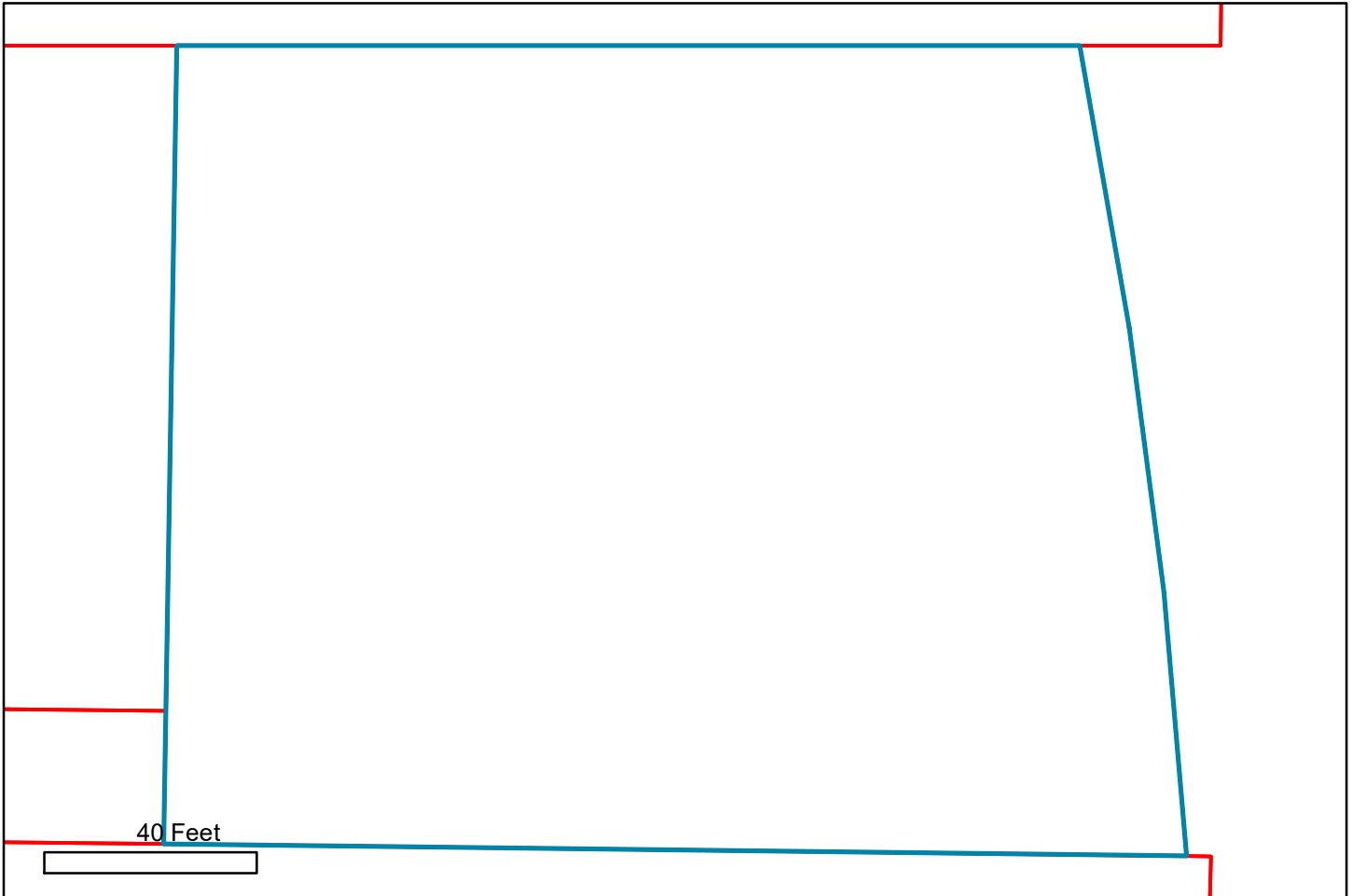

Parcel Information

Parcel Number: 53-05-28-300-136.000-005
Alt Parcel Number: 013-26360-00
Property Address: 1919 N College AVE
Bloomington, IN 47404
Neighborhood: 30 BLOOMINGTON CITY - COM - A
Property Class: Franchise-type Restaurant
Owner Name: Steak N Shake Operations Inc
Owner Address: C/O Ryan, LLC PO Box 460169
Houston, TX 77056
Legal Description: 013-26360-00 PT NW SW 28-9-1W .61A;
PLAT 42

Taxing District

Township: BLOOMINGTON TOWNSHIP
Corporation: MONROE COUNTY COMMUNITY

Land Description

<u>Land Type</u>	<u>Acreage</u>	<u>Dimensions</u>
11	0.61	

City of Bloomington's Board of Public Works
Order of Abatement for NOV

This matter is before the Board of Public Works for Abatement of Notice of Violations issued 11/03/2023, 11/17/2023, 11/30/2023, 12/15/2023, 01/26/2024, and 02/01/2024 (the "NOVs"). The Board of Public Works received information regarding the NOVs at its regular meeting on Tuesday, February 13, 2024.

The Board of Public Works now finds as follows:

1. Steak and Shake Operations, Inc. (hereinafter, the "Owner") owns the real estate located at 1919 N. College Ave., Bloomington, Indiana, with parcel number 53-05-28-300-136.000-005, and whose legal description is 013-26360-00 PT NW SW 28-9-1W .61A; PLAT 42 (hereinafter, the "Property").
2. On the dates noted above, Rebecca Davis, City of Bloomington Neighborhood Compliance Officer, issued the NOVs after personally observing garbage, rubbish, and trash deposited on the Property in violation of BMC § 6.06.020.
3. Substantial evidence in the form of photographs of the Property and eye witness testimony from Rebecca Davis establishes the need to abate the Property.
4. The NOVs were served on the Owner by mailing the NOV's to the Owner's last known address of: P.O. Box 460169 Houston, TX 77056 C/O Ryan, LLC, in accordance with BMC § 6.06.070(b).
5. The NOVs were not appealed and the violations were not remedied.
6. Notice of the City's request to abate the Property was served on the Owner of the Property by certified mail, and then by regular mail, both to the last known address of the Owner as identified above, all in accordance with BMC § 6.06.080(b).

After careful consideration of the evidence and testimony presented, the Board of Public Works now Orders as follows:

- A. The City, via either its employees or a third-party private contractor hired by the City, is authorized to enter into and onto the Property in order to bring said Property into compliance with Chapter 6.06 of the City of Bloomington Municipal Code. Specifically, the City, via either its employees or a third-party contractor hired by the City, is authorized to enter into and onto the Property to remove any and all garbage, rubbish, and trash as those terms are defined in Chapter 6.06 of the City of Bloomington Municipal Code.
- B. The City shall bill the Owner for all associated costs of abatement. The Owner shall remit payment in full no later than ten days from receipt of the bill.
- C. If the Owner fails to comply with paragraph B above, a certified copy of the statement of costs incurred by the City shall be filed in the office of the Monroe County Auditor. The Monroe County Auditor shall thereupon place the amount due on the tax duplicate for the Property.
- D. All appeals from the Board's decision on an abatement request shall be made to courts of competent jurisdiction within ten days.

So Ordered this 13th day of February, 2024.

Kyla Cox Deckard, President
Board of Public Works
City of Bloomington

The Board of Public Works meeting was held Tuesday, September 26, 2023 at 5:30 pm in the Council Chambers of City Hall at 401 N. Morton St., Bloomington, Indiana and virtually through Zoom with Kyla Cox Deckard presiding.

REGULAR MEETING OF THE BOARD OF PUBLIC WORKS

Present: Elizabeth Karon
Kyla Cox Deckard

ROLL CALL

City Staff: April Rosenberger - Public Works
Adam Wason – Public Works
Jason Kerr – Engineering
Michael Stewart -- Engineering
Alex Gray – Engineering
Maria McCormick -- Engineering
Driss Tahir – Engineering
Tim Street – Parks & Recreation
Larry Allen – Office of the Mayor
Aleks Pratt – Legal

Bid received from Ann-Kriss, LLC in the amount of \$138,000.00
Bid received from B&L Sheet Metal and Roofing in the amount \$161,900.00
Bids will be reviewed and an award of contract will be brought before the Board at a subsequent meeting.

OPENING OF SEALED BIDS
Restorative Roof Coating at Fire Station #2

None

MESSAGES FROM BOARD MEMBERS

David Ebbinghouse thanked the Board for tabling a motion at the previous meeting. He stated that for a lot of reasons, the public wasn't able to have a good engagement on this project. Ebbinghouse stated that he had been hearing from several people who are upset and he had become the "lightning rod" for this issue. He stated that the consensus is that people are upset with the aesthetics, placement and design, and the process by which the tower was selected. However, the upgrade to the park is most welcome.

PETITIONS & REMONSTRANCES

1. Approval of Minutes; July 18, 2023
2. Approval of Minutes; August 01, 2023
3. Approval of Minutes; August 15, 2023
4. Approval of Minutes; August 29, 2023
5. Approval of Minutes; September 12, 2023
6. Alley Closure Request from Economic & Sustainable Development for Mural Project
7. Resolution 2023-65; Renew Mobile Vendor; Top Shotta Jerk Chicken
8. Resolution 2023-66; Renew Mobile Vendor; Arepa Burger
9. Resolution 2023-67; Declaration of Bloomington Fire Department Surplus
10. Noise Permit Request for Harmony School Extravaganza
11. Approval of Payroll

CONSENT AGENDA

Board Comments: None

Karon made a motion to approve the Consent Agenda. Cox Deckard seconded. Cox Deckard took a roll call vote, all in favor, motion is passed.

Aleks Pratt, City Legal, presented Notice of Offering Real Estate for Sale; Bloomington Police Department Property with Extended Departure Date. See Meeting packet for details.

NEW BUSINESS
Notice of Offering Real Estate for Sale; Bloomington Police

**Department Property with
Extended Departure Date**

Board Comments: Karon asked for clarification on why the Board can recommend acceptance of an offer received at any time during the sales period, but bids could still continue to be received for up to 60 days. Pratt stated that this allows for bids to continue to be received, but in the event a bid looks acceptable, staff can bring that to the attention of the Board and the Board can consider accepting it at that point, even before the 60 day time period has expired. Cox Deckard asked what extended departure meant and if that occupancy is contingent on the departure of the Police Department from the facility. Pratt explained. Cox Deckard asked if that would be included as part of the purchase agreement. Pratt confirmed. Karon asked if the notice of publication is what the Board is considering and which department would be collecting the bid documents. Pratt stated staff would review and recommend to the Board any acceptable bid. Wason added that the Board is being asked to approve the notice of publication and that the next step for the Board of Public Works would be to approve an accepted offer based off of staff recommendation.

Public Comments: Dave Askins, B Square Bulletin, asked if the sale has to go before the City Council. He also asked about the difference in the bid opening process as his understanding is that bids will be opened and evaluated as they are received. Larry Allen, Deputy Mayor, explained that the process is different than a construction bid, in that it allows for an opening period of 60 days after the initial two weeks of notice. Allen confirmed that the City Council does have to approve. Karon asked if Allen could explain which bid process governs the opening process. Allen stated it is a very specific statute for the disposal of real estate.

Sally Jones, resident, asked about the timeline and the importance of the bid to go out in October if there is no date set for the Police Department to move. Wason explained that the public comment period is traditionally not used as a question and answer, but more so that the public can share their comments. Wason went on to say that as indicated in the Staff Report, the funding from the sale of the property would help fund the renovation of the Showers West facility that the Police Department would move into. Libby Karon, via zoom chat, asked who decides what constitutes a good bid. Wason explained that the information is outlined in the proposal process.

Karon made a motion to approve the Notice of Offering Real Estate for Sale; Bloomington Police Department Property with Extended Departure Date. Cox Deckard seconded. All in favor, motion is passed.

Jason Kerr, Engineering, presented Change Order #1 to Balance the Henderson St. Greenway Project. See meeting packet for details.

**Change Order #1 to Balance
the Henderson St. Greenway
Project**

Board Comments: None

Karon made a motion to approve the Change Order #1 to Balance the Henderson St. Greenway Project. Cox Deckard seconded. All in favor, motion is passed.

Jason Kerr, Engineering, presented Change Order #2 to Balance the Henderson St. Greenway Project. See meeting packet for details.

**Change Order #2 to Balance
the Allen St. Greenway Project**

Board Comments: None

Karon made a motion to approve the Change Order #2 to Balance the Henderson St. Greenway Project. Cox Deckard seconded. All in favor, motion is passed.

Mike Stewart, Engineering, presented Request from Shamrock Builders for Dumpster Placement in Right-of-Way at 201 N. Morton (October 2, 2023-January 15, 2024). See meeting packet for details.

**Request from Shamrock
Builders for Dumpster
Placement in Right-of-Way at
201 N. Morton (October 2,
2023-January 15, 2024)**

Board Comments: Karon asked if the dumpster would block sight lines. Stewart stated that it didn't appear so, that the dumpster has already been in place and hasn't proven to cause any issues.

Karon made a motion to approve Request from Shamrock Builders for Dumpster Placement in Right-of-Way at 201 N. Morton (October 2, 2023-January 15, 2024). Cox Deckard seconded. All in favor, motion is passed.

Adam Wason, Public Works, commented on the Lane and Sidewalk Closure Request from Reed and Sons for the Bloomington Gateway Project at Miller Showers Park (September 27, 2023 – December 22, 2023). Stated he recognizes that this item has received a lot of attention from the public. He stated he appreciates the Board's diligence in the matter. Wason reminded the public that the Board of Public Works did not approve the contracts for this project. Their purview is to consider the use of the public right-of-way. He asked the Board for their approval of the use of the right-of-way.

Lane and Sidewalk Closure Request from Reed and Sons for the Bloomington Gateway Project at Miller Showers Park (September 27, 2023 – December 22, 2023)

Board Comments: Cox Deckard asked if the information regarding the questions and comments would be available to the public who want to read more about the project. Tim Street, Parks and Recreation, stated that after corresponding with many people, the information is on the Parks website with a link on the project. Cox Deckard commented about the College and Walnut corridor study and is concerned how the activities will intersect. She asked to hear more about how updates for this project will be communicated with the College Walnut Corridor Committee. Wason stated the College Walnut corridor study covers a very large area of the north-south corridors of the city. Wason also said the Planning and Transportation staff is overseeing the corridor study and communication between their staff and other City staff happens constantly. He went on to state that the College Walnut Corridor study is just that, not a construction project. Cox Deckard stated she believe the Gateway element could be installed without the public improvements being made, which means even if the Board does not grant access to the right-of-way the structural elements of the gateway could be installed. Wason disagreed and stated that the basic permitted activities for the use of the right-of-way would still be needed in order for the structure to be installed. Cox Deckard clarified that the improvements being proposed are positive elements and would be much needed improvements to the area. Street stated that some of the public improvements could not be done without the right-of-way permit. Cox Deckard asked if this request included lane closure and accessibility of the crane. Street stated he did not believe so, that this request was to prepare the site for the installation of the structure. Street also stated that there are two contractors, so if there is an additional request, it may not come from Reed & Sons. Cox Deckard asked if the sidewalk work on the west side of Walnut Street was able to proceed, even though it is a separate project from what they are discussing. Wason stated it was paused because the Board delayed this right-of-way request and could not say for certain if it would move forward.

Public Comments: Sally Jones, Bloomington resident, said that there is enough that is unclear and asked the Board to deny any motions until alternatives to the monolith can be considered. She stated that the whole idea is not horrible, but it feels like an awful thing has been wrapped up in a nice package.

Susan Brackney, Bloomington resident, thanked the Board for tabling the request during the last meeting. She stated she went to the park and stood where the illuminated tower is supposed to be, so she could gain a better perspective. She stated she did not feel safe in that area. Brackney commented on the maintenance and long term upkeep. She stated that there are still a lot of unanswered questions that should be addressed before rushing to complete the project.

Cox Deckard stated that there are a lot of unanswered questions and that she still has concerns. Because of her questions and concerns, she stated she is not ready to vote for this

item and asked her fellow Board member to consider tabling the item again. Karon read a prepared statement regarding duties as a member of the Board of Public Works. She stated that after considerable time and thought, she would be voting in favor.

Karon made a motion to approve the Lane and Sidewalk Closure Request from Reed and Sons for the Bloomington Gateway Project at Miller Showers Park (September 27, 2023 – December 22, 2023). No second. Motion is failed.

Alex Gray, Engineering, presented Lane and Sidewalk Closure Request from Taycon at 613 E. 12th Street (September 6, 2023 - October 02, 2023). See meeting packet for details.

Board Comments: None

Karon made a motion to approve the Lane and Sidewalk Closure Request from Taycon at 613 E. 12th Street (September 6, 2023 - October 02, 2023). Cox Deckard seconded. Cox Deckard took a roll call vote, all in favor, motion is passed.

Maria McCormick, Engineering, presented Resolution 2023-59; Right-of-Way Encroachment request for Catalent Freezer Farm. See Meeting packet for details.

Board Comments: Karon asked what a freezer farm is. Bill Riggert, BRCJ, answered it is an enclosure of trailers, kept at -40 degrees Celsius that is used for long term storage of vaccines.

Karon made a motion to approve the Resolution 2023-59; Right-of-Way Encroachment request for Catalent Freezer Farm. Cox Deckard seconded. Cox Deckard took a roll call vote, all in favor, motion is passed.

Maria McCormick, Engineering, presented Road and Sidewalk Closure Request from Duke Energy at 1600 Block of S. Rogers St. (September 27, 2023-October 6, 2023). See Meeting packet for details.

Board Comments: Karon asked if residents had been notified of this closure. Liz Irwin, Duke Energy, stated that they have a process to notify residents and is usually includes a two day notification.

Karon made a motion to approve the Road and Sidewalk Closure Request from Duke Energy at 1600 Block of S. Rogers St. (September 27, 2023-October 6, 2023). Cox Deckard seconded. Cox Deckard took a roll call vote, all in favor, motion is passed.

Driss Tahir, Engineering, presented Lane and Sidewalk Closure Request from E&B Paving on S. Rogers St. (October 30, 2023-November 30, 2023). See meeting packet for details.

Board Comments: None

Karon made a motion to approve the Lane and Sidewalk Closure Request from E&B Paving on S. Rogers St. (October 30, 2023-November 30, 2023).

Wason commented that the upcoming weekend would be the 30th festival of Lotus.

Karon made a motion to approve claims in the amount of \$1,401,911.97. Cox Deckard seconded. Cox Deckard took a roll call vote, all in favor, motion is passed.

Cox Deckard called for adjournment at 6:03 p.m.

Lane and Sidewalk Closure Request from Taycon at 613 E. 12th Street (September 6, 2023-October 02, 2023)

Resolution 2023-59; Right-of-Way Encroachment request for Catalent Freezer Farm

Road and Sidewalk Closure Request from Duke Energy at 1600 Block of S. Rogers St. (September 27, 2023-October 6, 2023)

Lane and Sidewalk Closure Request from E&B Paving on S. Rogers St. (October 30, 2023-November 30, 2023)

STAFF REPORTS AND OTHER BUSINESS

APPROVAL OF CLAIMS

ADJOURNMENT

Accepted By:

Kyla Cox Deckard, President

Elizabeth Karon, Vice President

Date:

Attest to:

The Board of Public Works meeting was held Tuesday, October 10, 2023 at 5:30 pm in the Council Chambers of City Hall at 401 N. Morton St., Bloomington, Indiana and virtually through Zoom with Kyla Cox Deckard presiding.

**REGULAR MEETING OF
THE BOARD OF PUBLIC
WORKS**

Present: Kyla Cox Deckard
Elizabeth Karon
Jane Kupersmith

ROLL CALL

City Staff: April Rosenberger – Public Works
Adam Wason – Public Works
Beth Cate – Legal
Heather Lacy – Legal
Aleksandrina Pratt – Legal
Christopher Wheeler – Legal
Rob Council – HAND
Rebecca Davis – HAND
Maria McCormick – Engineering

Elizabeth Karon stated that there are a number of tragic things happening in the world and asked that participants retain some perspective during the meeting’s discussions.

**MESSAGES FROM BOARD
MEMBERS**

Kyla Cox Deckard extended a welcome to Board member Jane Kupersmith and thanked her for her service.

City Legal deferred to the appellant. After waiting several minutes, Cox Deckard asked the appellant to begin their report.

APPEALS
**Appeal Notice of Violation
62038-08-1314; 530 S.
Washington St.**

Adam Wason, Public Works, made a general statement about the appeal. Wason said that, in consultation with Corporation Counsel, City staff would be willing to meet with Mr. Davis on site to review the materials on his property, and that offer has been accepted by Mr. Davis. Wason said that City officials do intend to meet with Mr. Davis at his property, and added that the appeal should still proceed at this meeting.

Joe Davis, 530 S. Washington St., presented his appeal. Davis asked that Title 6 be displayed on the monitor, and added that his case depends on the parsing of Title 6. Wason stated that they did not currently have the ability to display Title 6, but the members of the Board were all furnished with copies. Davis asked that the appeal be delayed until Title 6 could be displayed for the benefit of the public to see and parse the language. Cox Deckard asked that the report continue and added that the Board did have hard copies of Title 6 in hand. Davis again asked that the report be delayed two weeks until the next meeting when the technology would allow the display of his materials. Wason stated that they would be able to display Title 6 at this meeting, and added that normally this kind of request should be made in advance but they would accommodate this instance, and to please proceed with the report. Davis again asked that the appeal be postponed until all of his documentation could be sent to the Board for review. Wason responded that every email sent by Mr. Davis had been submitted to the Board for review. Davis said that he also sent along 17 images, and asked if they had been included in the packet. Wason responded that the packet is not updated like that, and asked Davis to proceed with his appeal. Davis again asked that the appeal be postponed for two weeks until the next Board meeting so that his materials can be available to both the Board and the public at large. Davis added that he is being persecuted and singled-out. Cox Deckard acknowledged Davis’s request, and added that the appeal process is merely an opportunity for the appellant to present their case, and there is no guarantee of technology or other accommodations. Cox Deckard continued that this is the

opportunity to make the appeal, and that the Board is able to consider the appeal regardless of whether or not the appellant makes a report. Davis again asked for a two week delay for his appeal so that the public can review his materials. Cox Deckard asked Davis if he was declining to make his appeal at this time. Davis responded that he would like the appeal postponed. Cox Deckard acknowledged the request and asked that the City Legal Department begin their report. Wason asked Davis to vacate the podium and allow City staff to address the Board. Davis asked why City staff are going to make a presentation when he has requested that the appeal be delayed to the next Board meeting. Wason asked the Board if he could make a comment. Wason stated it had been a lengthy engagement between the City and Mr. Davis, lasting nearly 18 months, and there have been multiple postponements in recent week, at the City's request. Davis interrupted that he would like to request a postponement until the next Board meeting. Wason continued that this had been worked on in conjunction with Davis for many months, including information sharing, and that all materials have been shared with the Board members, and that the time for the appeal was at hand, and if Davis refused to make his appeal, then City staff would continue with the appeal process. Davis responded that it would be inappropriate for City staff to make a presentation if he was not able to make his full stated case, and that he was unable to make his case due to the technology not working and his materials not being entered into the Board packet. Wason stated that it is not the practice to allow Davis to dictate what is included in the Board packet, and added that there were other late requests that were not included in the packet because that is not how the process works. Wason again asked Davis if he would make his presentation or vacate the podium to allow the City Legal Department to make their presentation. Davis again stated it was not proper for City Legal to make a presentation if he was not allowed to make his full defense. Cox Deckard asked that City Legal make their presentation. Davis asked what will happen after City Legal taints the waters. Cox Deckard responded that the Board will make a decision on the appeal. Davis repeatedly asked that the appeal be delayed and that he was not being allowed to make his full case. Corporation Counsel Beth Cate asked to speak and Wason asked Davis to vacate the podium. Davis asked if he would still have the opportunity to present and Cox Deckard said they would afford him that opportunity. Davis stated that just prior to the meeting he was presented with images from City Legal Department member Chris Wheeler and that he did not have the opportunity to prepare a response. Cate made a statement that the City did indeed offer to have a multi-department meeting at Davis's property to review his materials, but she also made it clear that the relevant proceedings, both his appeal to the Board of Public Works at this meeting, and the Board of Zoning Appeals proceeding later in the month were on-going. Davis said that the meeting offer was made prior to the Board meeting, for a date in the future, and it would be inappropriate to deliver his appeal prior to the meeting taking place. Cate responded that the initial meeting offer message was sent to Davis unintentionally, which he accepted, and that the offer still stands. Cate again stated that she made it clear to Davis that the offer of a future meeting did not inhibit the relevant proceedings from going forward. Davis stated that he wanted the email exchange with Cate to be displayed at the meeting, and that he had not been receiving responses from City staff in relation to his case. Davis related a series of events he believed violated his right to due process, including that Christopher Wheeler had told City staff to not engage with him. Davis stated the images and descriptions of the items on his property were delivered to him only two business days before his appeal despite Board member Elizabeth Karon requesting them 8-10 months ago. Davis disagreed with the timeline and events described by Cate. Wason asked to make a statement and an offer to Davis: that the abatement of Davis's property would not happen until the meeting with City departments has taken place as described by Cate, but that the proceedings tonight must continue. Jane Kupersmith asked to make a comment, and stated that as a new member to the Board she felt she would be a good proxy for the public and would need to ask questions that would allow Davis to offer answers. City Legal asked to make a clarification on Wason's statements regarding Davis's court case but Davis would not yield the podium. Cox Deckard and Wason repeatedly asked Davis to vacate the podium so Legal could make their presentation. Davis repeatedly asked for a postponement of the appeal.

Cox Deckard called a recess at 6:10pm.

Christopher Wheeler, Legal, presented Appeal Notice of Violation 62038-08-1314; 530 S. Washington St. Rob Council, HAND, answered questions from Wheeler. The Board, Council, and Davis all reviewed a series of photos. Wheeler asked Council if the photos were taken by him and John Hewett of HAND. Council responded yes. Wheeler asked Council when the photos were taken. Council responded that they were taken the morning of September 26, 2023. Wheeler asked Council if he was on Davis's property when he took the photos. Council responded no. Wheeler asked Council if he was on the neighbor's property. Council said yes, and added that he had permission from both neighbors. Wheeler asked Council if he viewed the property on August 17, 2023, the day he issued the Notice of Violation. Council responded yes. Wheeler asked Council if the condition of the property on August 17 was reflected in the photos. Council responded yes. Wheeler asked Council if the exhibit list descriptions included with the photos, to help the Board understand the nature of the violations, was written by Council. Council responded yes. Wheeler asked Council if HAND believes that there are items of garbage or rubbish on the property. Council responded yes, and that they are violations of Title 6.

Board Comments: Kupersmith asked if the photos under review were different than what was circulated in the Board packet. Wheeler responded no.

Wheeler made a statement that the Notice of Violation was for a deposit of garbage on the property, and that Davis's characterization of the garbage as a random scattering is not what the City believed. Wheeler cited Municipal Code 6.06.020 and said that Davis's intentions for the garbage were not relevant, and that the continued deposit of garbage on his property resulted in the Notice of Violation. Wheeler said that the HAND department believed that Davis's appeal should be denied and the Notice of Violation should be upheld. Wheeler stated that if the Board believed the items in the photos are not garbage, then they should uphold Davis's appeal. The issue of storage of building materials would be discussed at the October 19, 2023 Board of Zoning Appeals, if the Board believed the items in the photos to be building materials, said Wheeler. Wheeler commented on Davis's Administrative Review Request of the Board's findings related to Notice of Violations and Abatements in the past, and stated that the court found Davis's complaint deficient, and dismissed the case. Wheeler added that Davis had appealed that decision.

Board Comments: Kupersmith asked if the August 17, 2023 Notice of Violation is the item being decided today. Wheeler responded yes, that was the only item under consideration for this appeal. Kupersmith asked about the amount of the fine. Wheeler responded that it would be \$50 total, and that a second fine within a 12 month period would be \$100, and a third and any subsequent fines within a 12 month period would be \$150. Kupersmith asked what an agreement between the City parties and Davis would look like and if Davis was amenable to such an agreement. Davis responded that he was amenable to the accepted offer of the verbal agreement, but not amenable to the follow-up email which revoked the offer. Wheeler said that he was not involved in the negotiations, it was Beth Cate. Wheeler added that when City staff visited Davis's property to help him identify items that were in violation, those staff were abused by Davis, who refused to allow them to do their job. Wheeler continued that the City is still open to an amicable resolution.

Karon asked if Cate was available to comment on the emails with Davis and the revoking of the agreement. Cate stated that the offer was not revoked, and it was made clear to Davis that the appeal process should still continue. Kupersmith asked about the paper trail of the proposed meeting at Davis's property. Wason explained to Cate about the deal to ensure the abatement of Davis's property would not happen until the interdepartmental meeting at his property. Kupersmith asked about what kind of contract or documents would be needed or helpful to articulate the deal, and Cate responded that the present documented Board

meeting would be adequate. Cate said that the City's enforcement of the City code is not dependent on the acquiescence of the party in violation of the code.

Cox Deckard stated that Davis would be given three minutes for any additional statements before the Board would render a decision. Davis objected to the proceedings and again asked for a postponement.

Cox Deckard called for recess at 6:45pm.

Cox Deckard made a motion to move two items to the end of the New Business agenda: 1) Appeal Notice of Violation 62038-08-1314; 530 S. Washington St., and 2) Request for Abatement at 530 S. Washington St. Karon seconded. Cox Deckard took a roll call vote, all in favor, motion is passed.

Mark Haggarty stated his concerns for the local government and alleged that rights are being violated. Haggarty reported an event where his wife was arrested for opposing the elimination of a greenspace near his home and lamented that a mayoral candidate was removed from the ballot.

Denice Valkyrie commented that she would like to see all three properties for the new county jail site be considered equally before a final decision is made.

Joe Davis commented that during a previous abatement experience, HAND workers removed materials from his truck and trailer. Davis said the abatement crew put the items back because they did not feel the items were garbage.

Jamie Shaw asked about the definition of garbage and recyclables through the lens of those who reuse and repurpose items. Shaw asked that local government play a role in defining what is considered waste and what is considered aesthetically pleasing.

Rebecca Davis, HAND, presented Request for Abatement at 1600 W. 3rd St. See meeting packet for details. Davis stated that she had been issuing citations from June through September, 2023.

Board Comments: Karon asked if Davis had any communications with the property owners, as they resided out of state. Davis stated that the initial citation was paid, indicating that it was received, but a later citation was returned through the mail. Davis said they tried sending to a new address but are uncertain if it was delivered. Karon asked if the Notice of Violations were issued for excessive growth or garbage. Davis responded the initial notice was for both, and the subsequent were for garbage.

Karon made a motion to approve the Request for Abatement at 1600 W. 3rd St. Kupersmith seconded. Cox Deckard took a roll call vote, all in favor, motion is passed.

1. Resolution 2023-71; New Mobile Vendor, Planted Bloomington, LLC
2. Resolution 2023-69; Bloomington Krampus Block Party
3. Resolution 2023-70; Fall Pop-Up Market
4. Outdoor Lighting Service Agreement with Duke Energy for Wingfield Subdivision
5. Addendum to Request for Sidewalk and Lane Closures from Centerpoint on Kinser Pike
6. Addendum to Request for Lane Closures from Centerpoint on E. 13th between N. Dunn and N. Walnut Grove
7. Approval of Payroll

Board Comments: None

Karon made a motion to approve the Consent Agenda. Kupersmith seconded. Cox Deckard

**PETITIONS&
REMONSTRANCES**

**TITLE VI ABATEMENT
REQUESTS
Request for Abatement at 1600
W. 3rd St.**

CONSENT AGENDA

took a roll call vote, all in favor, motion is passed.

Adam Wason, Public Works, asked that Professional Services Agreement with Griffin Realty to Assist with the Public Bidding Process for the Sale of the Police Building be removed from the agenda.

Karon made a motion to remove Professional Services Agreement with Griffin Realty to Assist with the Public Bidding Process for the Sale of the Police Building from the agenda. Kupersmith seconded. Cox Deckard took a roll call vote, all in favor, motion is passed.

Adam Wason, Public Works, asked that item #3 from the agenda be moved to item #2.

Karon made a motion to move Lane and Sidewalk Closure Request from Reed and Sons for the Bloomington Gateway Project at Miller Showers Park (October 16, 2023 –January 12, 2024) to item #2 on the agenda. Kupersmith seconded. Cox Deckard took a roll call vote, all in favor, motion is passed.

Adam Wason, Public Works, presented Lane and Sidewalk Closure Request from Reed and Sons for the Bloomington Gateway Project at Miller Showers Park (October 16, 2023 – January 12, 2024). See meeting packet for details. Wason explained there were two permits for lane closures under consideration: the first pertained to a number of public improvements in the Millers-Showers area, and the second pertained to the installation of a Gateway art piece that has been contracted through the Parks Department and has been approved by their Board.

Public Comments: Charlotte Zietlow spoke against the installation of the Gateway art piece. Zietlow said there did not seem to be adequate coverage of the approval process and that the piece was not aligned with Bloomington’s artistic sense and was not designed or built in Bloomington.

Susan Brackney asked the Board to approve permit #1 and table or deny permit #2. Brackney asked if the City is prepared for the variety of issues that would arrive along with the installation of the art piece, including damage to people and wildlife from the light pollution, and if there would be any corresponding changes to City code. Brackney said the Board is the last chance of pausing the installation of the art piece, even though that is not within the Board’s purview.

Betty Rose Nagle spoke against the installation of the Gateway art piece, and cited objections to the approval process and aesthetics. Nagle considered the art piece to be a mistake by Mayor Hamilton and asked the Board to save the city from his mistake. Nagle acknowledged that it is beyond the Board’s purview to deny the installation, but added they were the last opportunity to prevent the installation from proceeding.

Paula Hillary spoke against the installation of the Gateway art piece. Hillary said that she understood the Board should not be the ones to decide the fate of the project, but they were the last opportunity to stop it. Hillary cited problems with the art piece’s location, its representation of Bloomington, its impact on wildlife, and its use of funds that should be directed to other needs.

Joe Davis spoke against the installation of the Gateway art piece, and called it phallic and a waste of money.

David Ebbinghouse spoke against the installation of the Gateway art piece. Ebbinghouse acknowledged that it is beyond the Board’s purview to deny the installation, but added they were the failsafe to prevent the installation from proceeding. Ebbinghouse found it problematic that the improvements to the park were bundled together with the art

NEW BUSINESS
Professional Services Agreement with Griffin Realty to Assist with the Public Bidding Process for the Sale of the Police Building

Lane and Sidewalk Closure Request from Reed and Sons for the Bloomington Gateway Project at Miller Showers Park (October 16, 2023 –January 12, 2024)

installation.

Mark Riggins spoke against the installation of the Gateway art piece. Riggins stated that he and the public were not adequately informed about the project.

Jamie Shaw spoke against the installation of the Gateway art piece. Shaw cited the height and materials used in the art piece, and said that it would be a hazard if Bloomington were to experience an earthquake.

Jane Goodman, via Zoom, asked that the art piece be installed at a different location than Millers-Showers park, as it would disturb the wildlife at that location.

Unknown participant, via Zoom, spoke against the installation of the Gateway art piece.

Pileated via Zoom spoke against the installation of the Gateway art piece, and cited problems with the art piece's location, its representation of Bloomington, its impact on wildlife, and its use of funds that should be directed to other needs.

Unknown participant, via Zoom, spoke against the installation of the Gateway art piece, and added that the Board should table or deny the permit and let the City Council address it.

Shannon, via Zoom, spoke against the installation of the Gateway art piece, and cited concerns for environmental impact and negative effects on wildlife.

Andrea Kaiser, via Zoom, spoke against the installation of the Gateway art piece, and added that she has not heard any support for it.

Marilyn Behrman via Zoom spoke against the installation of the Gateway art piece, and added that she follows local news outlets closely and did not hear anything about the project.

Denice Valkyrie, via Zoom, spoke against the installation of the Gateway art piece. Valkyrie said that the public input process is inadequate. Valkyrie said there is already a monolith in Bloomington on the IU campus, intentionally placed where they do not want to attract birds, and to place a similar art piece in Millers-Showers park would negatively impact the wildlife there.

Shannon, via Zoom, said the light pollution from the art piece would negatively affect migrating birds who depend on darkness to navigate.

Diane, via Zoom, spoke against the installation of the Gateway art piece, and said that limestone should be used for the project.

Board Comments: Cox Deckard stated that the Board is tasked with approving the lane closure required for the site improvements, and that all other considerations for the project were made by the Parks Department and the Parks Board. Cox Deckard acknowledged the hard work of many City staff on the project, and their assistance with the associated questions from the Board and public. Cox Deckard asked that the Board be involved in the review process sooner, even if they are not signatories on a contract, and cited the current situation as problematic. Cox Deckard said there should be increased coordination between the various departments and stakeholders.

Karon made a motion to approve Lane and Sidewalk Closure Request from Reed and Sons for the Bloomington Gateway Project at Miller Showers Park (October 16, 2023 –January 12, 2024). No second. Motion failed.

Maria McCormick, Engineering, presented Sidewalk Closure Request from Michaelis Corp. on S. Walnut St. and E. Smith Ave. (Approximately 4 months). See meeting packet for details.

Sidewalk Closure Request from Michaelis Corp. on S. Walnut St. and E. Smith Ave. (Approximately 4 months)

Board Comments: Cox Deckard stated The Project School is in fall break for the upcoming weeks and have asked that the project move as quickly as possible.

Karon made a motion to approve Sidewalk Closure Request from Michaelis Corp. on S. Walnut St. and E. Smith Ave. (Approximately 4 months). Kupersmith seconded. Cox Deckard took a roll call vote, all in favor, motion is passed.

Adam Wason, Public Works, presented Contract with Ann-Kriss, LLC for Kitchen Renovations at Fire Station #2. See meeting packet for details.

Contract with Ann-Kriss, LLC for Kitchen Renovations at Fire Station #2

Kupersmith made a motion to approve Contract with Ann-Kriss, LLC for Kitchen Renovations at Fire Station #2. Cox Deckard seconded. Cox Deckard took a roll call vote, Karon abstained, Cox Deckard yes, Kupersmith yes, motion is passed.

Adam Wason, Public Works, presented Contract with Ann-Kriss, LLC for Restorative Roof Coating at Fire Station #2. See meeting packet for details.

Contract with Ann-Kriss, LLC for Restorative Roof Coating at Fire Station #2

Board Comments: None

Kupersmith made a motion to approve Contract with Ann-Kriss, LLC for Restorative Roof Coating at Fire Station #2. Cox Deckard seconded. Cox Deckard took a roll call vote, Karon abstained, Cox Deckard yes, Kupersmith yes, motion is passed.

Adam Wason, Public Works, presented Contract with Heflin, Industries, Inc. for Installation of Exhaust Hood at Fleet Maintenance Garage. See meeting packet for details.

Contract with Heflin, Industries, Inc. for Installation of Exhaust Hood at Fleet Maintenance Garage

Board Comments: None

Karon made a motion to approve Contract with Heflin, Industries, Inc. for Installation of Exhaust Hood at Fleet Maintenance Garage. Kupersmith seconded. Cox Deckard took a roll call vote, all in favor, motion is passed.

Cox Deckard called for a recess at 7:55pm.

Board Comments: Cox Deckard indicated her intention to move this appeal to the October 24, 2023 agenda. Cox Deckard commented that the Board packets are set in advance, typically the Friday prior to the meeting, and that there would be no adjustments or additions to the packets unless they are requested by the Board. Wason added that the public comment period is the opportunity for the public to share their input, and that such comments or materials are not added to the Board packet. Additional information from the public will be provided to Board members, but it will not necessarily be added to the packet. Cox Deckard clarified that there is no public comment opportunity for appeals as there is for abatements. Cox Deckard continued that there is no expectation by the appellant for technology or other support during the appeal, that it is intended to be an oral presentation supplemented by the materials supplied to the packet in advance. Cox Deckard said that there are practical time considerations as well, and that items sent to the Board in the hour before the meeting would likely not be reviewed. Wason stated that City staff still intend to meet with Mr. Davis as proposed. Wason and Cox Deckard agreed to allocate 15 minutes to both the appellant and City staff for their appeal presentations. Karon requested that all materials be shared with the Board at least 24 hours in advance.

APPEALS
Appeal Notice of Violation 62038-08-1314; 530 S. Washington St.

Cox Deckard made a motion to move Appeal Notice of Violation 62038-08-1314; 530 S.

Washington St. to the October 24, 2023 agenda. Kupersmith seconded. Cox Deckard took a roll call vote, all in favor, motion is passed.

Cox Deckard made a motion to move Request for Abatement at 530 S. Washington St. to the October 24, 2023 agenda. Kupersmith seconded. Cox Deckard took a roll call vote, all in favor, motion is passed.

**TITLE VI ABATEMENT
REQUESTS**
**Request for Abatement 530 S.
Washington St.**

Public Comments: Joe Davis requested that there be a court reporter available at the abatement and that he be able to cross-examine any City presenters.

Christopher Wheeler asked for clarification on the abatement proceedings in light of the Board’s request that all materials be submitted 24 hours in advance, and said that it is typical for the Board to ask about the condition of the property as it exists on the day of the abatement. The Board said it would issue guidance on that issue.

Jamie Shaw spoke in favor of Joe Davis and said he was an excellent teacher in the field of sustainable building practices. Shaw added that the materials in question on Davis’s property could be considered building materials or garbage depending on perspective, and said that the City’s stated goal of sustainability does not seem consistent with their persecution of the re-use of materials.

Cox Deckard commented that there will not be a court reporter present nor will there be the opportunity for cross-examination, as this is not a court of law.

Cox Deckard made a motion to move Request for Abatement at 530 S. Washington St. to the October 24, 2023 agenda. Kupersmith seconded. Cox Deckard took a roll call vote, all in favor, motion is passed.

**STAFF REPORTS AND
OTHER BUSINESS**

None

Karon made a motion to approve claims in the amount of \$1,921,311.25. Kupersmith seconded. Cox Deckard took a roll call vote, all in favor, motion is passed.

APPROVAL OF CLAIMS

Cox Deckard called for adjournment at 8:17 p.m.

ADJOURNMENT

Accepted By:

Kyla Cox Deckard, President

Elizabeth Karon, Vice President

Jane Kupersmith, Secretary

Date:

Attest to:

The Board of Public Works meeting was held Tuesday, October 24, 2023 at 5:30 pm in the Council Chambers of City Hall at 401 N. Morton St., Bloomington, Indiana and virtually through Zoom with Kyla Cox Deckard presiding.

REGULAR MEETING OF THE BOARD OF PUBLIC WORKS

Present: Elizabeth Karon
Kyla Cox Deckard

ROLL CALL

City Staff: April Rosenberger - Public Works
Adam Wason – Public Works
Rob Council – Housing & Neighborhood Development
Neil Kopper – Engineering
Driss Tahir - Engineering
Colleen Newbill – Legal
Aleks Pratt – Legal (Attended via Zoom)

None

MESSAGES FROM BOARD MEMBERS

Joe Davis, 530 S. Washington St., stated his concern for the amount of trash and discarded food that is in the proximity to the Shalom Center, and that this level of trash and food waste has led to a corresponding increase in the rat population around these areas. Davis removed a deceased rat from a bag as an example.

PETITIONS& REMONSTRANCES

Rob Council, HAND, presented Abatement at 2501 E. 8th Street. See meeting packet for details.

TITLE VI ABATEMENTS
Abatement at 2501 E. 8th Street.

Board Comments: Karon asked if there is anything the City can do to assist with the resident’s mental health concerns. Council confirmed that he has been working with this individual for a year and a half and has referred him to local agencies for help. Cox Deckard asked if the resident was present for comment. Council stated that he informed the resident of the public meeting and that he was invited to attend, but declined.

Karon made a motion to approve the request for Abatement at 2501 E. 8th Street. Cox Deckard seconded. Cox Deckard took a roll call vote, all in favor, motion is passed.

CONSENT AGENDA

1. Resolution 2023-68; Renewal for Mobile Vendor; Cup of Joy, LLC
2. Request for Installation of Protected Sidewalk Scaffolding at The Princess Theater
3. Alley Closure and Noise Permit for IU Film Production Event
4. Resolution 2023-73; Declaration of Surplus, City of Bloomington
5. Approval of Payroll

Board Comments: None

Karon made a motion to approve the Consent Agenda. Cox Deckard seconded. Cox Deckard took a roll call vote, all in favor, motion is passed.

Adam Wason, Public Works, and Neil Kopper, Engineering, presented Contract with American Structurepoint, Inc. for Signal Timing Project. See Meeting packet for details.

NEW BUSINESS
Contract with American Structurepoint, Inc. for Signal Timing Project

Board Comments: Karon asked if Kopper could state the last time a study of this kind was done and how frequently they typically happen. Kopper stated that the last study was 2016 and the guidance is to perform a study every five years.

Karon made a motion to approve the Contract with American Structurepoint, Inc. for Signal Timing Project. Cox Deckard seconded. Cox Deckard took a roll call vote, all in favor, motion is passed.

Neil Kopper, Engineering, presented MOU with CBU for Construction Cost Sharing on the Morningside Neighborhood Greenway Project. See meeting packet for details.

MOU with CBU for Construction Cost Sharing on the Morningside Neighborhood Greenway Project

Board Comments: None

Public Comments: Unidentified Zoom participant stated via chat that the local residents, specifically Park Ridge East neighborhood, were not informed of the project, and thus feedback was not received from those who will be affected by the project. Cox Deckard asked to clarify that there are still future items to be considered for this project. Kopper replied that there is still a bid process to go through and a proposed construction contract would still need to come before the Board for approval. Cox Deckard asked about the public input process. Kopper replied that the Planning and Transportation Department is charged with the public input process, in close coordination with Engineering, and that multiple avenues of input were included in this project.

Karon made a motion to approve the MOU with CBU for Construction Cost Sharing on the Morningside Neighborhood Greenway Project. Cox Deckard seconded. Cox Deckard took a roll call vote, all in favor, motion is passed.

Driss Tahir, Engineering, presented Lane and Alley Closures Request from Strauser Construction for New Building Project at 416 E Cottage Grove Ave. (December 12, 2023 – January 5, 2024). Tahir added that there is an additional closure request for the alley dating October 25, 2023 – July 15, 2024. See Meeting packet for details.

Lane and Alley Closures Request from Strauser Construction for New Building Project at 416 E Cottage Grove Ave. (December 12, 2023 – January 5, 2024)

Board Comments: Karon asked to clarify the dates. Tahir stated that the sidewalk closure is 14 days, December 12, 2023 – January 5, 2024, and the alley closure is October 25, 2023 – July 15, 2024, adding that the alley closure is partial, not total.

Karon made a motion to approve the Lane Closure Request from Strauser Construction for New Building Project at 416 E Cottage Grove Ave (December 12, 2023 – January 5, 2024) and Alley Closure Request from Strauser Construction for New Building Project at 416 E Cottage Grove Ave. (October 25, 2023 – July 15, 2024). Cox Deckard seconded. Cox Deckard took a roll call vote, all in favor, motion is passed.

Driss Tahir, Engineering, presented Sidewalk Closure Request from Strauser Construction for a Restoration Project at E .17th St. and N. Indiana Ave. (October 30, 2023-November 3, 2023). See Meeting packet for details. Adam Wason, Public Works, added that November 3 is a Friday, followed by a home IU football game on November 4, stating that they will ensure the sidewalk is open in time for the game.

Sidewalk Closure Request from Strauser Construction for a Restoration Project at E 17th St. and N. Indiana Ave. (October 30, 2023-November 3, 2023)

Board Comments: None

Karon made a motion to approve the Sidewalk Closure Request from Strauser Construction for a Restoration Project at E 17th St and N Indiana Ave (October 30, 2023-November 3, 2023.) Cox Deckard seconded. Cox Deckard took a roll call vote, all in favor, motion is passed.

Cox Deckard made a motion to add an agenda item: Noise Permit for 411 W. 8th St. for Gilliate General Contractors. Karon seconded. Cox Deckard took a roll call vote, all in favor, motion is passed.

Noise Permit for 411 W. 8th St. for Gilliate General Contractors (November 1, 2023)

Adam Wason, Public Works, presented Noise Permit for 411 W. 8th St. for Gilliate General Contractors. He explained that they are requesting two additional hours on either side of the permitted construction time, and that there are no residential areas that would be affected by the request.

Board Comments: Karon asked what dates are being requested for the permit. Wason responded that the request is for one day, November 1, 2023.

Karon made a motion to approve the Noise Permit for 411 W 8th St. for Gilliate General Contractors (November 1, 2023.) Cox Deckard seconded. Cox Deckard took a roll call vote, all in favor, motion is passed.

None

Board Comments: None

Karon made a motion to approve claims in the amount of \$1,050,776.14. Cox Deckard seconded. Cox Deckard took a roll call vote, all in favor, motion is passed.

Cox Deckard called for adjournment at 6:03 p.m.

Accepted By:

Kyla Cox Deckard, President

Elizabeth Karon, Vice President

**STAFF REPORTS AND
OTHER BUSINESS**

APPROVAL OF CLAIMS

ADJOURNMENT

Date:

Attest to:

The Board of Public Works meeting was held Tuesday, November 8, 2023 at 5:30 pm in the Council Chambers of City Hall at 401 N. Morton St., Bloomington, Indiana and virtually through Zoom with Kyla Cox Deckard presiding.

**REGULAR MEETING OF
THE BOARD OF PUBLIC
WORKS**

Present: Jane Kupersmith
Kyla Cox Deckard

ROLL CALL

City Staff: April Rosenberger – Public Works
J.D. Boruff – Public Works
Zac Rogers – Engineering
Colleen Newbill – Legal
Beth Cate – Legal
Alex Gray – Engineering
Maria McCormick – Engineering

None

**MESSAGES FROM BOARD
MEMBERS**

None

**PETITIONS &
REMONSTRANCES**

CONSENT AGENDA

1. Resolution 2023-64; Declaration of ITS Surplus
2. Resolution 2023-72; Declaration of ITS Surplus for Donation to Binary Heart
3. Resolution 2023-74; Canopy of Lights
4. Resolution 2023-75; Holiday Market
5. Outdoor Lighting Service Agreement with Duke Energy for the Franklin Road Business Park
6. Outdoor Lighting Service Agreement with Duke Energy for the Shadow Creek Subdivision
7. Addendum #1 to Contract with Ann-Kriss, LLC for Sanitation Garage Repairs
8. Addendum #1 to Contract with Ann-Kriss, LLC for Restorative Roof Coating at FS #2
9. 2024 Service Agreement with Ann-Kriss, LLC
10. 2024 Service Agreement with B&L Sheet Metal
11. 2024 Service Agreement with Bounds Flooring
12. 2024 Service Agreement with Bruce Home Improvements
13. 2024 Service Agreement with Cassidy Electric
14. 2024 Service Agreement with Commercial Service
15. 2024 Service Agreement with Economy Termite & Pest Control
16. 2024 Service Agreement with Everywhere Signs
17. Renewal #3 for ReCollect Systems, Inc.
18. Approval of Payroll

Board Comments: Cox Deckard made a motion to add the Service Agreements from the Consent Agenda to New Business for discussion as a whole. Kupersmith seconded. Cox Deckard took a roll call vote, all in favor, motion is passed.

Kupersmith made a motion to approve the Consent Agenda as amended. Cox Deckard seconded. Cox Deckard took a roll call vote, all in favor, motion is passed.

J.D. Boruff, Public Works, presented on the 2024 Service Agreements.

NEW BUSINESS
2024 Service Agreements

Board Comments: Kupersmith asked Boruff to explain the process for selecting these vendors and the rationale for using Service Agreements. Boruff explained that Service Agreements cover work with preferred vendors for routine repair and maintenance needs that fall below the \$5,000 threshold which would require a bid process, and they offer a more formalized process that protects the City in terms of liability. These types of work were previously approved at the staff level, as allowed by the State Board of Accounts, but it was determined by the City Legal and Controller Departments that a contract was required for any vendor that comes on to City property to perform work, and that a “hold harmless” clause must be included in such contracts along with their rates of service. Kupersmith asked Boruff how a vendor becomes a “preferred” vendor. Boruff responded that the City will often use vendors that they have used previously, who typically have working knowledge of City systems, and whose workmanship and practices they are comfortable with. As an example, Boruff cited HFI, who originally installed the City Hall HVAC system, and have been keeping it in good condition since then. Boruff added that, while the City will often rely on preferred vendors, they are actively adding new vendors, with a preference for local vendors, and they also will cease business with any vendors who are not performing adequately. Cox Deckard asked specifically about Commercial Service, and if this vendor offers a certain expertise. Boruff responded that the City is turning some facilities over to Commercial Service for maintenance now that the original warranty period has expired, citing Animal Care and Control as an example. Cox Deckard asked if Commercial Service performed the original installation of the Animal Care and Control system. Boruff responded that they did not, it was an out-of-town company.

Kupersmith made a motion to approve the 2024 Service Agreement with Ann-Kriss, LLC. Cox Deckard seconded. Cox Deckard took a roll call vote, all in favor, motion is passed.

Kupersmith made a motion to approve the 2024 Service Agreement with B&L Sheet Metal. Cox Deckard seconded. Cox Deckard took a roll call vote, all in favor, motion is passed.

Kupersmith made a motion to approve the 2024 Service Agreement with Bounds Flooring. Cox Deckard seconded. Cox Deckard took a roll call vote, all in favor, motion is passed.

Kupersmith made a motion to approve the 2024 Service Agreement with Bruce Home Improvements. Cox Deckard seconded. Cox Deckard took a roll call vote, all in favor, motion is passed.

Kupersmith made a motion to approve the 2024 Service Agreement with Cassady Electric. Cox Deckard seconded. Cox Deckard took a roll call vote, all in favor, motion is passed.

Kupersmith made a motion to approve the 2024 Service Agreement with Commercial Service. Cox Deckard seconded. Cox Deckard took a roll call vote, all in favor, motion is passed.

Kupersmith made a motion to approve the 2024 Service Agreement with Economy Termite & Pest Control. Cox Deckard seconded. Cox Deckard took a roll call vote, all in favor, motion is passed.

Kupersmith made a motion to approve the 2024 Service Agreement with Everywhere Signs. Cox Deckard seconded. Cox Deckard took a roll call vote, all in favor, motion is passed.

Zac Rogers, Engineering, presented Full Street Closure Request from Milestone Contractors on W. 2nd St. for Hopewell Project - Phase I. See meeting packet for details. Rogers added that 1st St. will be used as a detour, the north sidewalk on W. 2nd St. will remain open, and

**Full Street Closure Request
from Milestone Contractors on
W. 2nd St. for Hopewell**

relevant stakeholders will or have been notified.

Project - Phase I

Board Comments: Kupersmith asked if neighbors have been notified. A representative from Milestone confirmed that neighbors had been notified.

Kupersmith made a motion to approve the Full Street Closure Request from Milestone Contractors on W. 2nd St. for Hopewell Project - Phase I. Cox Deckard seconded. Cox Deckard took a roll call vote, all in favor, motion is passed.

Alex Gray, Engineering, presented Lane and Sidewalk Closure Request from Duke Energy along W. Belle Ave. near W. 3rd St. (December 01, 2023 - April 30, 2024). See meeting packet for details. Gray added that this request is different from the work happening on Rogers St. and the 17th and Dunn St. area, and that it will not involve metal poles, only replacing existing wooden poles. The closure will only affect the City right-of-way in the W. Belle Ave. area, and it will not be continuous for the whole 152 day time period. Duke will work with the local school to ensure communication. Cox Deckard asked if flaggers will be used to route pedestrian traffic, and Gray confirmed they will.

Lane and Sidewalk Closure Request from Duke Energy along W. Belle Ave. near W. 3rd St. (December 01, 2023 - April 30, 2024)

Kupersmith made a motion to approve the Lane and Sidewalk Closure Request from Duke Energy along W. Belle Ave. near W. 3rd St. (December 01, 2023 - April 30, 2024). Cox Deckard seconded. Cox Deckard took a roll call vote, all in favor, motion is passed.

Maria McCormick, Engineering, presented Sidewalk and Parking Lane Closure Request from Strauser Construction at 217 W. 6th St. to Remove Green Roof at Yellow Cab Company (November 13, 2023 – November 17, 2023). See meeting packet for details. McCormick added that pedestrians will be routed to the sidewalk on the north side of 6th St.

Sidewalk and Parking Lane Closure Request from Strauser Construction at 217 W. 6th St. to Remove Green Roof at Yellow Cab Company (November 13, 2023 – November 17, 2023)

Board Comments: Kupersmith asked if pedestrians will still be able to access businesses in the affected area. McCormick responded that she was not certain of the answer, but given the nature of the equipment being used, specifically a large crane, she guessed that there will not be pedestrian access. Kupersmith asked if information about the potential lack of pedestrian access has been communicated to relevant businesses. McCormick stated that she did not know, and added that the proposed work was something of an emergency situation, with time considerations to complete the work before snow and inclement weather would impact the roof, creating a potential failure. Cox Deckard added that the green roof was a stipulation of the plan approval, and the property owner will need to resolve that with the Planning and Transportation Department. McCormick stated that the owner is aware of that stipulation, and that the requested permit will not change the requirement for a green roof.

Kupersmith made a motion to approve the Sidewalk and Parking Lane Closure Request from Strauser Construction at 217 W. 6th St. to Remove Green Roof at Yellow Cab Company (November 13, 2023 – November 17, 2023). Cox Deckard seconded. Cox Deckard took a roll call vote, all in favor, motion is passed.

Maria McCormick, Engineering, presented Resolution 2023-76; Encroachment Agreement for 617 N. Madison. See meeting packet for details.

Resolution 2023-76; Encroachment Agreement for 617 N. Madison St.

Kupersmith made a motion to approve the Resolution 2023-76; Encroachment Agreement for 617 N. Madison St. Cox Deckard seconded. Cox Deckard took a roll call vote, all in favor, motion is passed.

None

STAFF REPORTS AND OTHER BUSINESS

Board Comments: None

APPROVAL OF CLAIMS

Kupersmith made a motion to approve claims in the amount of \$2,171,281.54. Cox Deckard seconded. Cox Deckard took a roll call vote, all in favor, motion is passed.

Cox Deckard called for adjournment at 5:53 p.m.

ADJOURNMENT

Accepted By:

Kyla Cox Deckard, President

Elizabeth Karon, Vice President

Date:

Attest to:

The Board of Public Works meeting was held Tuesday, November 21, 2023 at 5:30 pm in the Council Chambers of City Hall at 401 N. Morton St., Bloomington, Indiana and virtually through Zoom with Kyla Cox Deckard presiding.

REGULAR MEETING OF THE BOARD OF PUBLIC WORKS

Present: Kyla Cox Deckard
Elizabeth Karon
Jane Kupersmith

ROLL CALL

City Staff: April Rosenberger – Public Works
Adam Wason – Public Works
Aleksandrina Pratt – Legal (via Zoom)
Christopher Wheeler – Legal
Rob Council – HAND
Rachael Sargent – Planning and Transportation
Jason Moore – Fire

OPENING OF SEALED BIDS
Disposal Services of Municipal Solid Waste and Single Stream Recycling

Cox Deckard opened and read aloud two sealed bids.
Bid # 1 from Rumpke of Indiana, LLC. Item 1, Disposal Cost of Municipal Solid Waste Collected by the City, \$43/ton. Item 2, Disposal Cost of Single Stream Recycling Materials Collected by the City, \$68/ton.
Bid #2 from Republic Services of Indiana L.P. dba Transfer Station. Item 1, Disposal Cost of Municipal Solid Waste Collected by the City, \$43/ton. Item 2, Disposal Cost of Single Stream Recycling Materials Collected by the City, \$10/ton.

MESSAGES FROM BOARD MEMBERS

None

CONSENT AGENDA

1. 2024 Service Agreement with City Lawn
2. 2024 Service Agreement with Harrell Fish, Inc. for HVAC Repairs & Maintenance
3. 2024 Service Agreement with Harrell Fish, Inc. for Plumbing Repairs & Maintenance
4. 2024 Service Agreement with Indiana Door & Hardware
5. 2024 Service Agreement with Photizo dba Fish Window
6. Approval of Payroll

Karon made a motion to approve the Consent Agenda. Kupersmith seconded. Cox Deckard took a roll call vote, all in favor, motion is passed.

NEW BUSINESS
Resolution 2023-77; Renew Mobile Vendor, Community Kitchen

Adam Wason, Public Works, presented Resolution 2023-77; Renew Mobile Vendor, Community Kitchen. See Meeting Packet for details.

Board Comments: Kupersmith noted that Tim Klauer (sp?) is not the owner of the Community Kitchen, and said that it is likely just form language from the paperwork.

Kupersmith made a motion to approve Resolution 2023-77; Renew Mobile Vendor, Community Kitchen. Karon seconded. Karon took a roll call vote, Kupersmith yes, Karon yes, Cox Deckard abstained, motion is passed.

Cox Deckard made a motion to table the Lane and Sidewalk Closure Request from AEG.

Lane and Sidewalk Closure

Karon seconded. Cox Deckard took a roll call vote, all in favor, motion is passed.

Request from AEG

Rachael Sargent, Planning and Transportation, presented Consultant Agreement for the BMCMPPO 2050 Metropolitan Transportation Plan. See Meeting Packet for details.

Consultant Agreement for the BMCMPPO 2050 Metropolitan Transportation Plan

Karon made a motion to approve Consultant Agreement for the BMCMPPO 2050 Metropolitan Transportation Plan. Kupersmith seconded. Cox Deckard took a roll call vote, all in favor, motion is passed.

Jason Moore, Fire, presented Contract with Fox Construction for Fire Station #1 Renovation. See Meeting Packet for details.

Contract with Fox Construction for Fire Station #1 Renovation

Board Comments: Cox Deckard asked Moore to describe the location of Fire Station #1 and the purpose of the remodel. Moore said the location is 300 E. 4th St. Moore said the project was a long time in development and plans had to be redone after a flood in 2021. Moore said the project will be contained within the existing footprint of the building, with a part of it being slightly higher, the basement would be filled in, and it would result in a more modern fire station for all firefighters. Karon asked if the capacity for fire vehicles would be the same. Moore said yes.

Karon made a motion to approve Contract with Fox Construction for Fire Station #1 renovation. Kupersmith seconded. Cox Deckard took a roll call vote, all in favor, motion is passed.

Karon made a motion to approve Contract with Reed and Sons for Fire Station #1 Renovation. Kupersmith seconded. Cox Deckard took a roll call vote, all in favor, motion is passed.

Contract with Reed and Sons for Fire Station #1 Renovation

Moore stated that there was only one bid for this contract.

Contract with Harrell Fish, Inc. (HFI) for Fire Station #1 Renovation

Karon made a motion to approve Contract with Harrell Fish, Inc. (HFI) for Fire Station #1 Renovation. Kupersmith seconded. Cox Deckard took a roll call vote, all in favor, motion is passed.

Karon made a motion to approve Contract with Electric Plus for Fire Station #1 Renovation. Kupersmith seconded. Cox Deckard took a roll call vote, all in favor, motion is passed.

Contract with Electric Plus for Fire Station #1 Renovation

Cox Deckard referenced previously established parameters which stated there would be 15 minutes allocated for both the appellant and City staff.

APPEALS
Appeal Notice of Violation
62038-08-1314; 530 S.
Washington St

Joe Davis, 530 S. Washington St., presented his appeal. Davis said that his witnesses had not yet arrived and asked for a recess. Wason and Cox Deckard stated that there would be no recess and the time to present had begun. Davis repeated his request for a recess and Cox Deckard and Wason said no. Christopher Wheeler, Legal, stated that the City already made their case several weeks prior, and added that anybody who intended to present at the Board meeting should have arrived by the meeting's posted start time. Davis said that he was presented with images just prior to the meeting and did not have time to review them. Davis said that a meeting was held at his property on November 2 to review his materials, and was attended by John Zody, HAND, Scott Robinson, Planning and Transportation, Beth Cate,

Legal, Bobby LaRue, Monroe County Building Dept. Davis said that images and video were taken at this meeting. Davis said the images in the Board packet were out of date. Davis took issue with the presentation of the images. Davis said that it was agreed at the meeting that he would develop an inventory of the items on his property. Davis said that John Zody agreed to come to his property and review items one by one and that it would likely occur the following week. Davis said that Title 6 contains definitions of garbage but not definitions of building materials, and that the City referring to his items as garbage is not adequate proof that they are actually garbage. Davis felt that the City was not following through on the agreed-upon steps toward resolution and he didn't understand why his appeal was proceeding.

Wason said that the meeting did occur as Davis described, and that all materials submitted by Davis were passed along to the Board. Wason added that John Zody offered significant amounts of availability for a meeting but Davis had not accepted any of the times, and said that meeting could still occur in the future.

Board Comments: Cox Deckard asked Chris Wheeler, City Legal, which items on Davis's property were in violation of Title 6 and were under review. Wheeler referred to the photos that were presented during the October 10 Board of Public Works meeting, and gave a brief description of them, all of which were in various stages of decomposition, and were considered rubbish.

Cox Deckard allowed one minute for Davis to respond. Davis said that the items in the photos were not rubbish, and some were part of an art installation.

Karon made a motion to reject the Appeal Notice of Violation 62038-08-1314; 530 S. Washington St. Kupersmith seconded. Cox Deckard took a roll call vote, all in favor, motion is passed, appeal is denied.

Chris Wheeler, Legal, presented Request for Abatement 530 S. Washington St. Wheeler asked questions of Rob Council, HAND. Wheeler asked Council if he took the photographs that had been presented to the Board. Council said yes, the photos had been taken today, and they depicted the property at 530 S. Washington St. Wheeler asked Council how the Notice of Abatement was delivered to Davis. Council said he hand-delivered the Notice to Davis, and also sent a copy via certified mail, which was delivered and signed for by Davis on August 22, 2023. Wheeler asked Council if the photos showed the property in the same or very similar state as when the Notice was delivered to Davis. Council said yes. Wheeler asked Council if HAND recommends abatement as a result of failure to remedy. Council said yes.

Board Comments: Cox Deckard asked if there had been a previous abatement at this property. Council said yes, and added that the work was not completed within the one day allowed due to Davis preventing them from carrying out their tasks. Karon asked who was in attendance at the previous abatement. Council said it was himself, Chris Wheeler, Jo Stong, HAND, and three police officers, as well as the contractor used by the City for abatements. Wheeler said that there was a one-year time limit on carrying out an abatement after the notice was served, and asked that the Board deny any requests for continuances from Davis so that there would be adequate time to complete the abatement. Cox Deckard asked if this abatement pertains to any Title 20 violations in addition to Title 6. Wheeler said that the items under review were related to Title 6, and the Title 20 violations would go through a separate process involving the Planning and Transportation Department. Cox Deckard asked if the items depicted in the photos, described by the City as rubbish, would be the only items affected by this abatement. Wheeler said yes. Karon asked if the vehicles on the property would be affected by this abatement. Wheeler said no, vehicles are addressed under Title 20. Karon asked specifically about the vehicle parked in the street. Wheeler said that would be addressed by Parking through a separate

TITLE VI ABATEMENT
REQUESTS
Request for Abatement 530 S.
Washington St.

process. Wason said that HAND, Parking, and Planning and Transportation were working together to classify the items. Kupersmith asked if the abatement would include items on Davis's porch, or what the boundaries would be. Wheeler responded that HAND staff had been instructed to stay off the porch.

Davis was given 5 minutes to comment. Davis recalled the prior abatement and said that City staff were instructing the abatement contractors to remove items from his vehicle and other storage areas, but the contractors refused, saying the items were not garbage. Davis felt this demonstrated that there was not agreement about the nature of the materials on his property. Davis asked that the abatement proceedings be postponed until a meeting could occur with John Zody, HAND, to review and classify his materials.

Cox Deckard commented that it was important that the inventory of building materials be submitted as soon as possible. Wason said that it would be 10 business days before the abatement would commence, if approved. Davis again requested that the meeting with Zody occur. Cox Deckard stated that the email chain between Davis and Zody indicated that there was ample opportunity for the two to meet, but Davis did not take advantage. Cox Deckard added that the meeting could still occur during the 10 day period.

Davis continued to object to the proceedings.

Public Comments: Jamie Shaw spoke in support of Davis. Shaw expressed concern for the definitions or lack thereof used in Title 6 to describe items that are in violation.

Mark Haggerty described what he felt was gentrification in Bloomington, and said that for people like himself and Davis, the only option to live in the city was to be in an older low-cost home that needed repair. Haggerty was concerned about the lack of candidates on the recent election ballot.

Karon made a motion to approve the Request for Abatement 530 S. Washington St. Kupersmith seconded. Cox Deckard took a roll call vote, all in favor, motion is passed.

None.

None.

Cox Deckard called for adjournment at 6:48 p.m.

**STAFF REPORTS AND
OTHER BUSINESS**

APPROVAL OF CLAIMS

ADJOURNMENT

Accepted By:

Kyla Cox Deckard, President

Elizabeth Karon, Vice President

Jane Kupersmith, Secretary

Date:

Attest to:



Board of Public Works Staff Report

Project/Event: Disposal of Surplus Items by the City of Bloomington – Information & Technology Services

Staff Representative: Rick Dietz

Date: January 22, 2023

Report:

The Department of Information & Technology Services has a large stock of computer equipment and peripherals that are inoperable and/or recyclable.

The Department of Information & Technology Services staff believe that the expense of labor, equipment, and fuel required to organize and transport all of this equipment for a sale or transfer exceeds the value of the equipment. These items are identified in Exhibit A of Resolution 2024-03: City Civil Recycle Lot 28 beginning December 2023 and in Exhibit B of Resolution 2024-03: Bloomington Police Department Recycle Lot 66 beginning July 2023.

Recommendation and Supporting Justification:

Under Indiana Code § 5-22-22-6, the City of Bloomington Board of Public Works may determine these devices to be surplus property and may conduct a public or private sale or transfer the property without advertising, as there is more than one (1) item with an estimated value of less than five thousand dollars (\$5,000). Alternatively, under Indiana Code § 5-22-22-7, the City of Bloomington Board of Public Works may determine these devices to be surplus property and may sell the property at a public or private sale or transfer the property without advertising if the property may be recycled and has been collected in conjunction with a recycling program.

Recommend: Approval Denial by: Rick Dietz

**BOARD OF PUBLIC WORKS
RESOLUTION 2024-03**

**TO DISPOSE OF SURPLUS PERSONAL PROPERTY
OWNED BY THE CITY OF BLOOMINGTON**

WHEREAS, the City of Bloomington Information & Technology Services Department (“ITS”) purchases and provides equipment for City Departments including, but not limited to, computers, computer hard drives, keyboards, monitors, and other computer accessories, which are used by a significant portion of City employees in order to assist the employees in their work on behalf of the City; and

WHEREAS, all of this equipment has limited life cycles; and

WHEREAS, as this equipment becomes inoperable and/or outdated it is returned to ITS by City Departments, and ITS provides those Departments with new replacement equipment; and

WHEREAS, ITS has a large stock of returned equipment which ITS wishes to dispose of as surplus personal property; and

WHEREAS, this equipment is identified in Exhibit A and Exhibit B which are attached hereto and incorporated herein by reference; and

WHEREAS, pursuant to Indiana Code § 5-22-22-6, the City of Bloomington Board of Public Works (hereinafter “Board of Public Works”) may determine this equipment to be surplus property and may conduct a private sale or transfer the property without advertising, as there is more than one (1) item, and the value of this inoperable and/or outdated equipment is less than five thousand dollars (\$5,000); and

WHEREAS, ITS has assessed the value of this equipment contained in Exhibit A and Exhibit B to be less than five thousand dollars (\$5,000); and

WHEREAS, pursuant to Indiana Code § 5-22-22-8, the Board of Public Works is also authorized to consider this equipment worthless, if the value of the equipment is less than the estimated cost of the sale and transportation of the equipment; and

WHEREAS, in considering the expense of labor, equipment and fuel required to organize and transport all of this equipment contained in Exhibit A and Exhibit B for a sale or transfer, ITS believes that these costs exceed the value of the equipment; and

WHEREAS, ITS believes that the equipment should be transferred for destruction and/or recycling.

NOW, THEREFORE, be it hereby resolved by the Board of Public Works that:

1. The equipment contained in Exhibit A and Exhibit B are hereby declared to be surplus personal property.

2. The value of the equipment contained in the Exhibit is assessed to be less than five thousand dollars (\$5,000).
3. The costs of transporting this equipment and conducting a private sale exceed the value of the equipment.
4. The equipment contained in Exhibit A and Exhibit B are therefore determined to be worthless and, pursuant to Indiana Code § 5-22-22-8, may be demolished, offered for recycling, donated or junked.

PASSED AND ADOPTED by the City of Bloomington Board of Public Works this _____ day of _____, 2024.

BOARD OF PUBLIC WORKS

Kyla Cox Deckard, President

Elizabeth Karon, Vice President

James Roach, Secretary

DocuSigned by:
Rick Dietz
Attest: _____
E114F3F9AEE0424...
Rick Dietz, Director
Information & Technology Services

EXHIBIT A**ITS Department/City of Bloomington****Technology Recyclers Recycle Lot 28 - 2024**

Lot ID: 61 Date: 12/13/2023 Recycle

Recycle Items List

Asset ID	Asset No.	Serial No.	Name	Category	Division	Date	Recycle Location
3148	100349	A6LMTF022880	PLN100349	LCD 1	Planning	01/29/2024	Technology Recyclers Recycle Lot 28 - 2024
3043	1601868F	P002G29FRC	ESD1601868F	UPS	Economic & Sustainable Development	01/22/2024	Technology Recyclers Recycle Lot 28 - 2024
3583	1601868c		PRS1601868c	UPS	Parks and Recreation	01/22/2024	Technology Recyclers Recycle Lot 28 - 2024
3056	1602063E	P002G38JPT	PWS1602063E		Public Works	01/11/2024	Technology Recyclers Recycle Lot 28 - 2024
3504	120011	112NDMT8Y171	CNT120011	LCD 2	Controller	01/05/2024	Technology Recyclers Recycle Lot 28 - 2024
3574	100370	A7LMTF136449	ent100370	LCD 2	Controller	01/05/2024	Technology Recyclers Recycle Lot 28 - 2024
3503	130012	C1LMQT002060	CNT130012	LCD 1	Controller	01/05/2024	Technology Recyclers Recycle Lot 28 - 2024
7483	1805533K		PLN1805533K	UPS	Engineering	01/05/2024	Technology Recyclers Recycle Lot 28 - 2024
4166	1600972J	G002G03426	tlr1600972J	UPS	Twin Lakes Recreation Center	12/28/2023	Technology Recyclers Recycle Lot 28 - 2024
3048	070169	H2106B06252W0	esd070169	UPS	Economic & Sustainable Development	12/28/2023	Technology Recyclers Recycle Lot 28 - 2024
7477	231227C		231227C	Desktop Scanner	Customer Services	12/27/2023	Technology Recyclers Recycle Lot 28 - 2024
7475	231227A		231227A	TV	Dillman	12/27/2023	Technology Recyclers Recycle Lot 28 - 2024
7476	231227B		231227B	TV	Dillman	12/27/2023	Technology Recyclers Recycle Lot 28 - 2024
2895	1702755C	P002H06JR3	1702755C	UPS	HAND	12/26/2023	Technology Recyclers Recycle Lot 28 - 2024
3316	156354A	G002F16228	hrd156354A	UPS	Employee Services	12/26/2023	Technology Recyclers Recycle Lot 28 - 2024
5783	1805981I		TLR1805981I	Docking Station	Twin Lakes Recreation Center	12/20/2023	Technology Recyclers Recycle Lot 28 - 2024
3371	1702380E		CFR1702380E	UPS	Community and Family Resources	12/20/2023	Technology Recyclers Recycle Lot 28 - 2024
5567	1806068		STR1806068	Monitor	Street	12/18/2023	Technology Recyclers Recycle Lot 28 - 2024
7459	1504093B		STR1504093B	LCD 1		12/18/2023	Technology Recyclers Recycle Lot 28 - 2024
7457	100300		STR100300	LCD 1		12/18/2023	Technology Recyclers Recycle Lot 28 - 2024

Box #20 Keyboards, speakers, and cables**Box #21 Toner Cartridges****Box #22 Power strips, and batteries**

EXHIBIT B**ITS Department/City of Bloomington*****Recycle Lot 66 BPD Only - 2024**

Lot ID: 66 Date: 01/23/2024 Recycle

Recycle Items List

Asset ID	Asset No.	Serial No.	Name	Category	Division	Date	Recycle Location
5978	1806104C		dis1806104C	Desktop	Police Dispatch	01/24/2024	*Recycle Lot 66 BPD Only - 2024
5979	1806104b		dis1806104b	Desktop	Police Dispatch	01/24/2024	*Recycle Lot 66 BPD Only - 2024
1691	1525013g	1WYVV52	pws1525013g	Desktop	Public Works	01/24/2024	*Recycle Lot 66 BPD Only - 2024
5405	1805663g	B9GPHQ2	pop1805663g	Desktop	Uniformed Officers	01/24/2024	*Recycle Lot 66 BPD Only - 2024
4903	1703934b	4VWN0M2	dis1703934b	Desktop	Police Dispatch	01/24/2024	*Recycle Lot 66 BPD Only - 2024
6188	1907973b	1SS94Z2	pop1907973b	Desktop	Uniformed Officers	01/24/2024	*Recycle Lot 66 BPD Only - 2024
7546			Radio Monitor			01/24/2024	*Recycle Lot 66 BPD Only - 2024
7533	1702837F		Detective Monitor			01/23/2024	*Recycle Lot 66 BPD Only - 2024
7523	130579a		Dispatch Monitor			01/23/2024	*Recycle Lot 66 BPD Only - 2024
7532	120120		Detective Monitor			01/23/2024	*Recycle Lot 66 BPD Only - 2024
7531	130539		Dispatch Monitor			01/23/2024	*Recycle Lot 66 BPD Only - 2024
7530	130513		Dispatch Monitor			01/23/2024	*Recycle Lot 66 BPD Only - 2024
7529	130535		Dispatch Monitor			01/23/2024	*Recycle Lot 66 BPD Only - 2024
7528	130524		Dispatch Monitor			01/23/2024	*Recycle Lot 66 BPD Only - 2024
7527	130531A		Dispatch Monitor			01/23/2024	*Recycle Lot 66 BPD Only - 2024
7526	130531		Dispatch Monitor			01/23/2024	*Recycle Lot 66 BPD Only - 2024
7525	130571		Dispatch Monitor			01/23/2024	*Recycle Lot 66 BPD Only - 2024
7524	130584		Dispatch Monitor			01/23/2024	*Recycle Lot 66 BPD Only - 2024
7522	131111b		Dispatch Monitor			01/23/2024	*Recycle Lot 66 BPD Only - 2024
7534	100135		Detective Monitor			01/23/2024	*Recycle Lot 66 BPD Only - 2024
7535	1804271		Detective Monitor			01/23/2024	*Recycle Lot 66 BPD Only - 2024
7536	1908263N		Desktop PC			01/23/2024	*Recycle Lot 66 BPD Only - 2024
7537	1908263O		Desktop PC			01/23/2024	*Recycle Lot 66 BPD Only - 2024
7539	1908263K		Desktop PC			01/23/2024	*Recycle Lot 66 BPD Only - 2024
6180	1907973c	1ST34Z2	pod1907973c	Desktop	Detectives	01/23/2024	*Recycle Lot 66 BPD Only - 2024
7538	1908263L		Desktop PC			01/23/2024	*Recycle Lot 66 BPD Only - 2024
6300	1908263m	BSYFBZ2	pos1908263m	Desktop		01/23/2024	*Recycle Lot 66 BPD Only - 2024
5498	1805663h	B9HMHQ2	pod1805663h	Desktop	Detectives	01/23/2024	*Recycle Lot 66 BPD Only - 2024
4193	100364		f2x100364	NetworkPrinter		01/23/2024	*Recycle Lot 66 BPD Only - 2024
1689	15030075	CNF8H32FZ2	Morton St Parking Garage	NetworkPrinter		01/23/2024	*Recycle Lot 66 BPD Only - 2024
7507	130542		Dispatch Monitor			01/23/2024	*Recycle Lot 66 BPD Only - 2024
7493	130579A		Dispatch Monitor			01/23/2024	*Recycle Lot 66 BPD Only - 2024
7494	130519		Dispatch Monitor			01/23/2024	*Recycle Lot 66 BPD Only - 2024
7495	130538A		Dispatch Monitor			01/23/2024	*Recycle Lot 66 BPD Only - 2024
7496			Dispatch Monitor			01/23/2024	*Recycle Lot 66 BPD Only - 2024
7497	130580		Dispatch Monitor			01/23/2024	*Recycle Lot 66 BPD Only - 2024
7498	130532		Dispatch Monitor			01/23/2024	*Recycle Lot 66 BPD Only - 2024
7499	131111e		Dispatch Monitor			01/23/2024	*Recycle Lot 66 BPD Only - 2024

7500	130521		Dispatch Monitor			01/23/2024	*Recycle Lot 66 BPD Only - 2024
7501	130540		Dispatch Monitor			01/23/2024	*Recycle Lot 66 BPD Only - 2024
7502	130538		Dispatch Monitor			01/23/2024	*Recycle Lot 66 BPD Only - 2024
7503	130582		Dispatch Monitor			01/23/2024	*Recycle Lot 66 BPD Only - 2024
7504	130534		Dispatch Monitor			01/23/2024	*Recycle Lot 66 BPD Only - 2024
7505	131111a		Dispatch Monitor			01/23/2024	*Recycle Lot 66 BPD Only - 2024
7506	130576		Dispatch Monitor			01/23/2024	*Recycle Lot 66 BPD Only - 2024
7492	130549A		Dispatch Monitor			01/23/2024	*Recycle Lot 66 BPD Only - 2024
7508	130528		Dispatch Monitor			01/23/2024	*Recycle Lot 66 BPD Only - 2024
7509	130547		Dispatch Monitor			01/23/2024	*Recycle Lot 66 BPD Only - 2024
7510	1525657C		Dispatch Monitor			01/23/2024	*Recycle Lot 66 BPD Only - 2024
7511	100234		Dispatch Monitor			01/23/2024	*Recycle Lot 66 BPD Only - 2024
7512	100152		Dispatch Monitor			01/23/2024	*Recycle Lot 66 BPD Only - 2024
7513	1804278		Dispatch Monitor			01/23/2024	*Recycle Lot 66 BPD Only - 2024
7514	100159		Detective Monitor			01/23/2024	*Recycle Lot 66 BPD Only - 2024
7515	130536		Detective Monitor			01/23/2024	*Recycle Lot 66 BPD Only - 2024
7516	130572		Dispatch Monitor			01/23/2024	*Recycle Lot 66 BPD Only - 2024
7517	130579		Dispatch Monitor			01/23/2024	*Recycle Lot 66 BPD Only - 2024
7518	130518		Dispatch Monitor			01/23/2024	*Recycle Lot 66 BPD Only - 2024
7519	130530		Dispatch Monitor			01/23/2024	*Recycle Lot 66 BPD Only - 2024
7520	130526		Dispatch Monitor			01/23/2024	*Recycle Lot 66 BPD Only - 2024
7521	130549		Dispatch Monitor			01/23/2024	*Recycle Lot 66 BPD Only - 2024

- 1 Box of Keyboards Tech Recyclers
- 2 Box of Misc. Cables Tech Recyclers
- 3 TV Tech Recyclers
- 4 Box of Toner Tech Recyclers
- 5 2 projectors Tech Recyclers
- 6 Range Kiosk Cabinet Tech Recyclers
- 7 BPD Kiosk Tech Recyclers



Board of Public Works Staff Report

Project/Event: Disposal of Surplus Items by the City of Bloomington – Information & Technology Services

Staff Representative: Rick Dietz

Date: January 22, 2023

Report:

The Department of Information & Technology Services has a large stock of computer equipment and peripherals that are inoperable and/or outdated.

The Department of Information & Technology Services staff believe that the expense of labor, equipment, and fuel required to organize and transport all of this equipment for a sale or transfer, exceeds the value of the equipment. These items are identified in Exhibit A to Resolution 2024-04: Donation Lot 29 City Hall.

Recommendation and Supporting Justification:

Under Indiana Code § 5-22-22-6, the City of Bloomington Board of Public Works may determine these devices to be surplus property and may conduct a public or private sale or transfer the property without advertising, as there is more than one (1) item with an estimated value of less than five thousand dollars (\$5,000). Alternatively, under Indiana Code § 5-22-22-7, the City of Bloomington Board of Public Works may determine these devices to be surplus property and may sell the property at a public or private sale or transfer the property without advertising if the property may be recycled and has been collected in conjunction with a recycling program.

Recommend: Approval Denial by: Rick Dietz

**BOARD OF PUBLIC WORKS
RESOLUTION 2024-04**

**TO DISPOSE OF SURPLUS PERSONAL PROPERTY
OWNED BY THE CITY OF BLOOMINGTON**

WHEREAS, the City of Bloomington Information & Technology Services Department (“ITS”) purchases and provides equipment for City departments including, but not limited to, computers, computer hard drives, keyboards, monitors, and other computer accessories, which are used by a significant portion of City employees in order to assist the employees in their work on behalf of the City; and

WHEREAS, all of this equipment has limited life cycles; and

WHEREAS, as this equipment becomes inoperable and/or outdated it is returned to ITS by City departments; and

WHEREAS, ITS has a large stock of returned equipment which ITS wishes to dispose of as surplus personal property (the “Property”) and further identified in Exhibit A, which is attached hereto and incorporated by reference; and

WHEREAS, ITS wishes to transfer the Property without advertising; and

WHEREAS, Indiana Code § 5-22-22-6 permits the City of Bloomington Board of Public Works (the “Board”) to conduct a public or private sale or transfer the Property without advertising as there is more than one (1) item with an estimated value of less than five thousand dollars (\$5,000); and

WHEREAS, ITS has assessed the value of the Property to be less than five thousand dollars (\$5,000); and

WHEREAS, Indiana Code § 5-22-22-8 permits the Board to deem the Property if the value of the Property is less than the estimated cost of the sale and transportation of the Property; and

WHEREAS, in considering the expense of labor, equipment and fuel required to organize and transport the Property for sale or transfer, ITS believes that these costs exceed the value of the Property; and

WHEREAS, ITS has offered the Property as a donation to a local nonprofit organization.

NOW, THEREFORE, be it hereby resolved by the Board of Public Works that:

1. The City of Bloomington property described in Exhibit A is hereby declared to be surplus personal property.
2. The value of the Property is assessed to be less than five thousand dollars (\$5,000).

3. The costs to organize and transport the Property for sale or transfer exceed the value of the Property.
4. ITS shall donate and transfer the Property to that certain nonprofit organization stated in Exhibit A.

PASSED AND ADOPTED by the City of Bloomington Board of Public Works this _____ day of _____, 2024.

BOARD OF PUBLIC WORKS

Kyla Cox Deckard, President

Elizabeth Karon, Vice President

James Roach, Secretary

DocuSigned by:
Rick Dietz
Attest: _____
E114F9F9AEEB424...
Rick Dietz, Director
Information & Technology Services

EXHIBIT A

ITS Department/City of Bloomington
BinaryHeart Donation Lot 29 - 2024

Asset Num	Name/Make	Device Type	Installed Date	Pickup Organization	AssetTrack Removal Date
130138	MACBOOK	Laptop	01/01/13	BinaryHeart	12/07/2023
1501633	ITS1501633	Laptop	01/01/15	BinaryHeart	12/08/2023
1907313	CFR1907313	Laptop	08/08/2019	BinaryHeart	12/08/2023
1525667a	MACBOOK	Laptop	01/01/15	BinaryHeart	12/07/2023
1525667c	MACBOOK	Laptop	01/01/15	BinaryHeart	12/07/2023
1525667d	MACBOOK	Laptop	01/01/15	BinaryHeart	12/07/2023
1805419k	esd1805419k	Laptop	08/13/2018	BinaryHeart	12/08/2023
1805920b	its1805920b	Laptop	01/13/0201	BinaryHeart	12/07/2023
1805981A	PLN1805981A	Laptop	11/27/2018	BinaryHeart	12/08/2023
1908400B	LGL1908400B	Laptop	01/13/2020	BinaryHeart	12/07/2023
1908440Q	ITS1908440Q	Laptop	10/24/2019	BinaryHeart	12/07/2023
1908840B	ASH1908840B	Laptop	03/04/2020	BinaryHeart	12/08/2023
1908842B	PRS1908842B	Laptop	02/13/2020	BinaryHeart	12/08/2023
2008996B	DELL LAPTOP	LATITUDE 5500	02/13/2020	BinaryHeart	12/07/2023
2010926C	DELL LAPTOP	PRECISION 5540	02/13/2020	BinaryHeart	12/07/2023
		7 Laptop Bags		BinaryHeart	12/07/2023
		14 Power Cables		BinaryHeart	12/07/2023
		1 pair of headphones		BinaryHeart	12/07/2023



Board of Public Works Staff Report

Project/Event: Disposal of Surplus Items by the City of Bloomington – Information & Technology Services

Staff Representative: Rick Dietz

Date: January 22, 2023

Report:

The Department of Information & Technology Services has a large stock of computer equipment and peripherals that are inoperable and/or outdated.

The Department of Information & Technology Services staff believe that the expense of labor, equipment, and fuel required to organize and transport all of this equipment for a sale or transfer, exceeds the value of the equipment. These items are identified in Exhibit A to Resolution 2024-05: Donation Lot 30 City Hall.

Recommendation and Supporting Justification:

Under Indiana Code § 5-22-22-6, the City of Bloomington Board of Public Works may determine these devices to be surplus property and may conduct a public or private sale or transfer the property without advertising, as there is more than one (1) item with an estimated value of less than five thousand dollars (\$5,000). Alternatively, under Indiana Code § 5-22-22-7, the City of Bloomington Board of Public Works may determine these devices to be surplus property and may sell the property at a public or private sale or transfer the property without advertising if the property may be recycled and has been collected in conjunction with a recycling program.

Recommend: Approval Denial by: Rick Dietz

**BOARD OF PUBLIC WORKS
RESOLUTION 2024-05**

**TO DISPOSE OF SURPLUS PERSONAL PROPERTY
OWNED BY THE CITY OF BLOOMINGTON**

WHEREAS, the City of Bloomington Information & Technology Services Department (“ITS”) purchases and provides equipment for City departments including, but not limited to, computers, computer hard drives, keyboards, monitors, and other computer accessories, which are used by a significant portion of City employees in order to assist the employees in their work on behalf of the City; and

WHEREAS, all of this equipment has limited life cycles; and

WHEREAS, as this equipment becomes inoperable and/or outdated it is returned to ITS by City departments; and

WHEREAS, ITS has a large stock of returned equipment which ITS wishes to dispose of as surplus personal property (the “Property”) and further identified in Exhibit A, which is attached hereto and incorporated by reference; and

WHEREAS, ITS wishes to transfer the Property without advertising; and

WHEREAS, Indiana Code § 5-22-22-6 permits the City of Bloomington Board of Public Works (the “Board”) to conduct a public or private sale or transfer the Property without advertising as there is more than one (1) item with an estimated value of less than five thousand dollars (\$5,000); and

WHEREAS, ITS has assessed the value of the Property to be less than five thousand dollars (\$5,000); and

WHEREAS, Indiana Code § 5-22-22-8 permits the Board to deem the Property if the value of the Property is less than the estimated cost of the sale and transportation of the Property; and

WHEREAS, in considering the expense of labor, equipment and fuel required to organize and transport the Property for sale or transfer, ITS believes that these costs exceed the value of the Property; and

WHEREAS, ITS has offered the Property as a donation to a local nonprofit organization.

NOW, THEREFORE, be it hereby resolved by the Board of Public Works that:

1. The City of Bloomington property described in Exhibit A is hereby declared to be surplus personal property.
2. The value of the Property is assessed to be less than five thousand dollars (\$5,000).

3. The costs to organize and transport the Property for sale or transfer exceed the value of the Property.
4. ITS shall donate and transfer the Property to that certain nonprofit organization stated in Exhibit A.

PASSED AND ADOPTED by the City of Bloomington Board of Public Works this _____ day of _____, 2024.

BOARD OF PUBLIC WORKS

Kyla Cox Deckard, President

Elizabeth Karon, Vice President

James Roach, Secretary

DocuSigned by:
Rick Dietz
Attest: _____
E114E3E9AEEED424...
Rick Dietz, Director
Information & Technology Services

EXHIBIT A

ITS Department/City of Bloomington
MCCSC Donation Lot 30 - 2024

Asset Num	Name/Make	Device Type	Installed Date	Pickup Organization	AssetTrack Removal Date
1703926	hrd1703926	Laptop	01/13/2021	MCCSC	12/08/2023
1703994	FRS1703994	Laptop	12/15/2017	MCCSC	12/08/2023
18046646	DELL LAPTOP	LATITUDE 5580	01/24/2018	MCCSC	12/07/2023
1703080c	its1703080c	Laptop	09/21/2017	MCCSC	12/07/2023
1703563a	esd1703563a	Laptop	10/20/2017	MCCSC	12/08/2023
1703563B	DELL LAPTOP	LATITUDE 5480	10/20/2017	MCCSC	12/07/2023
1703720a	prs1703720a	Laptop	10/20/2017	MCCSC	12/07/2023
1703828a	clk1703828a	Laptop	01/25/2018	MCCSC	12/07/2023
1703828e	clk1703828e	Laptop	01/24/2018	MCCSC	12/07/2023
1703927c	fle1703927c	Laptop	02/08/2018	MCCSC	12/07/2023
1803323g	ash1803323g	Laptop	04/04/2018	MCCSC	12/08/2023
1803323h	ash1803323h	Laptop	04/09/2018	MCCSC	12/08/2023
1803323I	ASH1803323I	Laptop	06/26/2018	MCCSC	12/07/2023
1805419b	clk1805419b	Laptop	08/07/2018	MCCSC	12/07/2023
1805559b	cnt1805559b	Laptop	08/16/2018	MCCSC	12/07/2023
1805563e	lgl1805563e	Laptop	08/31/2018	MCCSC	12/07/2023
1805920c	its1805920c	Laptop	01/22/2019	MCCSC	12/08/2023
1907408b	pln1907408b	Laptop	06/25/2019	MCCSC	12/07/2023
2008855H	DELL LAPTOP	RUGGED EXTREME	06/26/2020	MCCSC	12/07/2023
		20 Power Cables		MCCSC	12/07/2023
		20 Laptop Bags		MCCSC	12/07/2023
		20 Mice		MCCSC	12/07/2023



Board of Public Works Staff Report

Project/Event: Contract Service Agreement
Petitioner/Representative: Street Department
Staff Representative: Joe Van Deventer
Meeting Date: February 13, 2024

Precision Concrete, Inc., is proposing a saw cut solution (not grinding) for the City of Bloomington, to remove sidewalk trip hazards on sidewalks located in various locations. Trip hazards will be eliminated leaving a maximum running slop (ramp) of 1:8 as permitted to meet ADA requirements. Precision Concrete Services will correct 1,350 trip hazards. This is a continuous project to repair trip hazards within the City.

Precision Concrete Cutting **\$ 100,000**

City of Bloomington Contract and Purchase Justification Form

Vendor: Precision Concrete, Inc.

Contract Amount: \$100,000

This form should be completed and attached to the contract documents and forwarded to the Legal Department Attorney assigned to your Department. Contracts will not be approved by the Controller if a completed form is not included with the contract documents.

PURCHASE INFORMATION

1. Check the box beside the procurement method used to initiate this procurement: (Attach a quote or bid tabulation if applicable)

<input type="checkbox"/> Request for Quote (RFQ)	<input type="checkbox"/> Request for Proposal (RFP)	<input type="checkbox"/> Sole Source	<input checked="" type="checkbox"/> Not Applicable (NA)
<input type="checkbox"/> Invitation to Bid (ITB)	<input type="checkbox"/> Request for Qualifications (RFQu)	<input type="checkbox"/> Emergency Purchase	

2. List the results of procurement process. Give further explanation where requested. Yes No

	Yes	No		
# of Submittals:			Was the lowest cost selected? (If no, please state below why it was not.)	<input checked="" type="checkbox"/> <input type="checkbox"/>
Met city requirements?	<input checked="" type="checkbox"/>	<input type="checkbox"/>	Municipal discount	
Met item or need requirements?	<input checked="" type="checkbox"/>	<input type="checkbox"/>		
Was an evaluation team used?	<input type="checkbox"/>	<input checked="" type="checkbox"/>		
Was scoring grid used?	<input type="checkbox"/>	<input checked="" type="checkbox"/>		
Were vendor presentations requested?	<input type="checkbox"/>	<input checked="" type="checkbox"/>		

3. State why this vendor was selected to receive the award and contract:

Precision Concrete, Inc. is proposing a saw cut solution (not grinding) for the City of Bloomington, to remove sidewalk trip hazards on sidewalks located in various locations. Trip hazards will be eliminated leaving a maximum running slop (ramp) of 1:8 as permitted to meet ADA requirements. Precision Concrete, Inc., will correct approximately 1,400 trip hazards.

Joe VanDeventer

Director of Operations

Public Works/Street Division

Print/Type Name

Print/Type Title

Department



January 22, 2024



City of Bloomington

Attn: Joe Van Deventer, Director of Street Operations
1981 S Henderson
Bloomington, IN 47401

Phone: (812) 349-3448 Cell: (812) 327-3336 Email: vandevej@bloomington.in.gov

Subject: **SIDEWALK TRIP HAZARD ELIMINATION, Proposal for City of Bloomington, Spring 2024**

Joe,

We appreciate the opportunity to submit this proposal for the City of Bloomington. Total cost for this project will **not exceed \$100,000** based on an agreed scope and job rate. Upon your review and acceptance of this proposal, **please sign and return** (or submit a valid purchase order referencing this proposal) via FAX to (616) 582-5951 or email us at **info@PCCMich.com**.

Our W-9 and proof of insurance (an ACORD) is current and on file. Let us know if any additional information or documents are required before we begin work. We appreciate the opportunity to provide our service.

Precision Concrete Cutting

Precision Concrete Cutting (PCC) has been removing trip hazards from uneven sidewalks and other concrete walkways across the nation for over 25 years. As the industry leader in technology and price, PCC can reduce liability associated with uneven sidewalk and help meet ADA compliance with a method more effective and less expensive than alternatives. PCC utilizes its patented tools and processes that it has developed and refined for trip hazard removal. Not only is trip hazard removal the specialty of PCC... it's the only thing we do. PCC has dozens of locations across the country. Precision Concrete, Inc. is the locally licensed business unit serving Indiana, Michigan, Central Illinois, and Missouri that leverages the proven tools, process, and training to provide this service.

The Advantage

The Precision Concrete Cutting (PCC) service removes the entire trip hazard from side to side on the entire sidewalk while other methods of repair often leave a portion of the trip hazard. Not only can PCC reach the edges of every sidewalk, we can remove trip hazards from virtually any angle and at any location. Trip hazards caused by cracked concrete or located in hard-to-reach places such as in gutters or adjacent to a wall, post, or railing will be eliminated without any damage to nearby impediments. **There is no other process of trip hazard removal available with the quality, flexibility, and diversity as that of PCC.**



Quality

The Precision Concrete Cutting (PCC) process involves the measurement of every sidewalk trip hazard identified. PCC inspects the sidewalks and takes specific measurements to identify and log each trip hazard size and location. These measurements are used to determine the size of repair that is required, and to guarantee that the repair is made to dimensional specifications.

The PCC finished repair is aesthetically pleasing, smooth, and of superior quality compared to alternatives. It does not leave grooves in the surface of the concrete, it is not uneven, and is left with an acceptable coefficient of friction to not create slip hazards.



Environmental & Community Friendly

The Precision Concrete Cutting (PCC) process does not require heavy equipment in the work area. The PCC equipment is small and maneuvered about by individual employees. No damage is created to buildings, landscaping, irrigation systems, or the surrounding environment. Complete cleanup of the work area is performed and dust abatement systems minimize dust. All materials removed are properly recycled.

PCC utilizes a patented dust collection system to keep dust to a minimum while performing its work. This is a great benefit over other repair processes that leave the area covered in concrete dust or slurry. PCC also cleans up the removed concrete and debris created while performing the repairs and disposes (for recycle) of it as part of the service. Being a complete solution, no follow-on tasks are required of the City of Bloomington staff. Sidewalks remain open with only minor disruption while PCC moves thru an area performing the trip hazard removals.

As a member of the U.S. Green Building Council (USGBC) we are proud of the fact that we reduce the impact to landfills and the environment as a result of our service. For example, **removing and replacing just 50 sidewalk panels would result in approximately 60,000 lbs of concrete being removed** (your average 5' x 5' panel weighs about 1,200 lbs). Using Precision Concrete Cutting, sidewalk trip hazard removal can be accomplished by removing about 400 lbs of concrete that will be recycled. No heavy equipment or hauling is required. Also, there is no damage to trees or adjoining landscape with Precision Concrete Cutting.



Real Savings

Precision Concrete Cutting (PCC) leverages new technology and unique equipment to perform sidewalk repairs at a 70-80% cost savings compared to sidewalk replacement. It is estimated that this project will **save City of Bloomington over \$500,000 on repairs.**

Professional Plan and Approach

Precision Concrete Cutting (PCC) will conduct a pre-construction planning meeting with the City's designated contact(s) using a PCC Project Manager to establish priorities, a high-level schedule for each job site, review risks/constraints, and safety plans. The Project Manager will assure schedule, scope, and budget objectives are attained for the project. The PCC Delivery Manager will assure quality and safety objectives are attained during the onsite work phase of the project.

PCC will deploy a well-marked light-duty pickup truck/van and full logo trailer used to mobilize up to three (3) full sets of cutting equipment and operators. Safety cones are placed wherever the truck/van and trailer park and they are placed on the sidewalks in front of and behind the operator area to assure pedestrian safety during cutting. All PCC staff (including project manager) wears high-visibility safety vests whenever they are outside their vehicle.



Scope and Cost

Precision Concrete Cutting (PCC) is proposing a SAW CUT solution (NOT GRINDING) for the City of Bloomington to remove contiguous sidewalk trip hazards on walkways to be determined by the City. PCC would typically bill for this project at the rate of \$58 per Inch Foot (defined as the average inch height of the trip hazard x linear feet of the hazard). However, PCC will offer a municipal project rate of \$44/IF. For this project, PCC will perform up to 2,273 IF of trip hazard removal (up to the established project budget). It is estimated this project will resolve over 1,350 sidewalk trip hazards. Billing will be based on actual work performed, **without exceeding the approved budget of \$100,000.**

The scope of the sidewalk trip hazards is defined as a differential in the walkway of .375" high but less than or equal to 1.5" high. Trip hazards will be eliminated leaving a maximum running slope (ramp) of 1:8 as permitted to meet ADA requirements. The work will be performed on City sidewalks in the project areas prioritized by the City. *Note: Areas to be determined by City may contain more than 2,272 IF of trip removal. PCC will work in the City's prioritized order, up to the approved or amended City project budget;*

Job No. (Area)	Location	(Remove and Replace)	Estimated # of Trip Hazards Cut	Estimated Linear Feet	Estimated Inch Feet	Cost	
1	Area 1 determined by City	0	135	567	227.27	\$13,181.82	
2	Area 2 determined by City (as budget allows)	0	135	567	227.27	\$13,181.82	
3	Area 3 determined by City (as budget allows)	0	135	567	227.27	\$13,181.82	
4	Area 4 determined by City (as budget allows)	0	135	567	227.27	\$13,181.82	
5	Area 5 determined by City (as budget allows)	0	135	567	227.27	\$13,181.82	
6	Area 6 determined by City (as budget allows)	0	135	567	227.27	\$13,181.82	
7	Area 7 determined by City (as budget allows)	0	135	567	227.27	\$13,181.82	
8	Area 8 determined by City (as budget allows)	0	135	567	227.27	\$13,181.82	
9	Area 9 determined by City (as budget allows)	0	135	567	227.27	\$13,181.82	
10	Area 10 determined by City (as budget allows)	0	135	567	227.27	\$13,181.82	
Totals		0	1,350	5,670	2,272.73	\$131,818.18	
						Additional Services:	\$0.00
						Travel and Expenses:	\$0.00
						Discount* :	-\$31,818.18
Net Proposed Total:							\$100,000.00

*Municipal discount will apply if project is accepted prior to March 1, 2024, and with an authorization to proceed with project by March 29, 2024 (weather and schedule permitting).

MAP: Work area(s) will be determined by City.

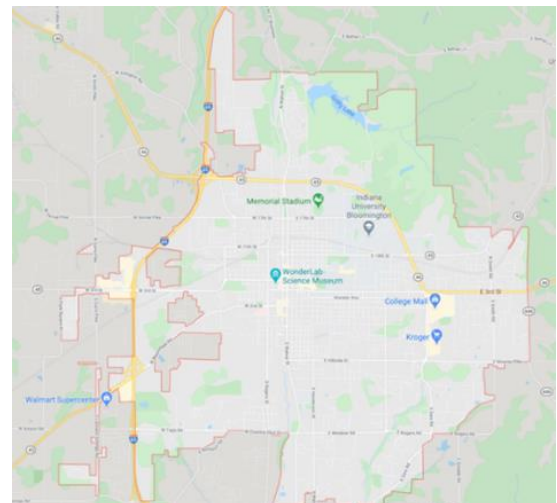

Sole Source Status

The technology that Precision Concrete Cutting uses to remove trip hazards has been developed and patented by Precision Concrete Cutting based in Provo, UT. Precision Concrete Cutting and its local branches are the only companies authorized to use the patented equipment and method for removing sidewalk trip hazards as described by the following patent numbers:

U.S. Patent No. 6,827,074
U.S. Patent No. 6,896,604
U.S. Patent No. 7,000,606

U.S. Patent No. 7,143,760
U.S. Patent No. 7,201,644
U.S. Patent No. 7,402,095

These patent numbers and the Precision Concrete Cutting (PCC) licensing agreement make Precision Concrete, Inc. a sole source for trip hazard removal in Indiana using this technology.

Invoicing

A Precision Concrete Cutting (PCC) invoice will be issued for work completed at the conclusion of the project. Payment terms are net 15 days from the date work is completed unless contract states otherwise. PCC will not charge the City of Bloomington any additional fees for mobilization, setup, cleanup, or travel / expenses. All such fees are included in the proposed price.

An itemized invoice listing the location of each trip hazard resolved will be listed and can be provided in hard copy or soft copy as required by the City of Bloomington. This itemized list provides the City with a completely auditable summary of the work performed by PCC. It is also a document that can support the fact that your organization has a proactive sidewalk maintenance program in place.

Summary

Precision Concrete Cutting is very interested in working with the City of Bloomington to deliver a proactive and cost-effective sidewalk maintenance program to help with the efforts of ADA compliance and reduce liabilities associated with sidewalk trip hazards. Our goal is to foster a long-term relationship in which we can help the City of Bloomington achieve its annual sidewalk maintenance objectives.



Thank you for your consideration. Signature and date below confirms your acceptance of this proposal.

Rick Anderson, Business Dev Manager, Indiana
and **Mark Bonkowski** (President)

Precision Concrete, Inc.
1896 Goldeneye Drive
Holland MI 49424

(317) 618-0611 Cell

(616) 403-1140 Office
(616) 582-5951 Fax

Customer

authorized signature / date

printed name / title

**AGREEMENT BETWEEN CITY OF BLOOMINGTON
PUBLIC WORKS DEPARTMENT AND
PRECISION CONCRETE, LLC**

This Agreement, entered into on this 13th day of February, 2024, by and between the City of Bloomington Department of Public Works (the “Department”), and Precision Concrete, LLC (“Contractor”).

Article 1. Scope of Services After receiving a **Notice to Proceed**, Contractor shall perform repair and maintenance services of the following types: remove trip hazards from uneven sidewalks and other concrete walkways within the City. Contractor shall diligently provide the Services under this Agreement and shall complete the Services described in this Agreement in a timely manner consistent with the Standard of Care identified in Article 2. Contractor shall complete the Services required under this Agreement on or before December 31, 2024, unless the parties mutually agree to a later completion date. Completion shall mean completion of all work related to the Services. In the performance of Contractor’s work, Contractor agrees to maintain such coordination with the Department as may be requested and desirable, including primary coordination with Joe Van Deventer, Director of Street Operations, Public Works Department. Contractor agrees that any information or documents, including digital GIS information, supplied by the Department pursuant to Article 3, below, shall be used by Contractor for this project only, and shall not be reused or reassigned for any other purpose without the written permission of the Department.

Article 2. Standard of Care Contractor shall be responsible for completion of the Services in a manner consistent with that degree of care and skill ordinarily exercised by members of the same profession currently practicing under similar circumstances (“Standard of Care”). The Department shall be the sole judge of the adequacy of Contractor’s work in meeting the Standard of Care; however, the Department shall not unreasonably withhold its approval as to the adequacy of Contractor’s performance. Upon notice to Contractor and by mutual agreement between the parties, Contractor will, without additional compensation, correct or replace any and all Services not meeting the Standard of Care.

Article 3. Responsibilities of the Department The Department shall provide all necessary information regarding requirements for the Services. The Department shall furnish such information as necessary for the orderly progress of the work, and Contractor shall be entitled to rely upon the accuracy and completeness of such information. The Department’s Project Manager shall act on its behalf with respect to this Agreement.

Article 4. Compensation The Department shall pay Contractor for all fees and expenses in an amount not to exceed One Hundred Thousand Dollars (\$100,000.00). Contractor shall submit an invoice to the Department upon the completion of the Services described in Article 1. The invoice shall be sent to: Joe Van Deventer, City of Bloomington Public Works, 401 N. Morton, Suite 120, Bloomington, Indiana 47404. Invoices may be sent via first class mail postage prepaid or via email. Payment will be remitted to Contractor within forty-five (45) days of receipt of invoice. Additional services not set forth in Article 1, or changes in the Services must be authorized in writing by the Department or its designated project coordinator prior to such work being performed, or expenses incurred. The Department shall not make payment for any unauthorized work or expenses.

Article 5. Appropriation of Funds Notwithstanding any other provision of this Agreement, if funds for the continued fulfillment of this Agreement by the Department are at any time not forthcoming or are insufficient, through failure of any entity, including the Department itself, to appropriate funds or otherwise, then the Department shall have the right to terminate this Agreement without penalty.

Article 6. Schedule Contractor shall perform the Services according to the following schedule: Services will be on as needed basis upon request of the Department. The time limits established by this schedule shall not be exceeded, except for reasonable cause as mutually agreed to by all parties.

Article 7. Termination In the event of a party's substantial failure to perform in accordance with the terms of this Agreement, the other party shall have the right to terminate the Agreement upon written notice. The nonperforming party shall have fourteen (14) calendar days from the receipt of the termination notice to cure or to submit a plan for cure acceptable to the other party. Additionally, the Department may terminate or suspend performance of this Agreement at the Department's prerogative at any time upon written notice to Contractor. Contractor shall terminate or suspend performance of the Services on a schedule acceptable to the Department and the Department shall pay the Contractor for all the Services performed up to the date that written notice is received, plus reasonable termination or suspension expenses. Upon restart, an equitable adjustment shall be made to Contractor's compensation and the schedule of services. Upon termination or suspension of this Agreement, all finished or unfinished reports, drawings, collections of data and other documents generated by Contractor in connection with this Agreement shall become the property of the Department, as set forth in Article 9 herein.

Article 8. Identity of the Contractor Contractor acknowledges that one of the primary reasons for its selection by the Department to perform the Services is the qualifications and experience of Contractor. Contractor thus agrees that the Services to be performed pursuant to this Agreement shall be performed by Contractor. Contractor shall not subcontract any part of the Services without the prior written permission of the Department. The Department reserves the right to reject any of the Contractor's personnel or proposed outside professional sub-Contractors, and the Department reserves the right to request that acceptable replacement personnel be assigned to the project.

Article 9. Ownership of Documents and Intellectual Property All documents, drawings and specifications, including digital format files, prepared by Contractor and furnished to the Department as part of the Services shall become the property of the Department. Contractor shall retain its ownership rights in its design, drawing details, specifications, databases, computer software and other proprietary property. Intellectual property developed, utilized or modified in the performance of the Services shall remain the property of Contractor.

Article 10. Independent Contractor Status During the entire term of this Agreement, Contractor shall be an independent contractor, and in no event shall any of its personnel, agents or sub-contractors be construed to be, or represent themselves to be, employees of the Department. Contractor shall be solely responsible for the payment and reporting of all employee and employer taxes, including social security, unemployment, and any other federal, state, or local taxes required to be withheld from employees or payable on behalf of employees.

Article 11. Indemnification Contractor shall indemnify and hold harmless the City of Bloomington, the Department, and the officers, agents and employees of the City and the Department from any and all claims, demands, damages, costs, expenses or other liability arising out of the Agreement or occasioned by the reckless or negligent performance of any provision thereof, including, but not limited to, any reckless or negligent act or failure to act or any misconduct on the part of the Contractor or its agents or employees, or any independent contractors directly responsible to it (collectively "Claims").

Article 12. Insurance During the performance of any and all Services under this Agreement, Contractor shall maintain the following insurance in full force and effect: a) General Liability Insurance, with a minimum combined single limit of \$1,000,000 for each occurrence and \$2,000,000 in the aggregate; b) Automobile Liability Insurance, with a minimum combined single limit of \$1,000,000 for each person and \$1,000,000 for each accident; c) Workers' Compensation Insurance in accordance with the statutory requirements of Title 22 of the Indiana Code; and d) Professional Liability Insurance ("Errors and Omissions Insurance") with a minimum limit of \$1,000,000 annual aggregate. All insurance policies shall be issued by an insurance company authorized to issue such insurance in the State of Indiana. The City of Bloomington, the Department, and the officers, employees and agents of each shall be named as insureds under the General Liability, Automobile, and Worker's Compensation policies, and such policies shall

stipulate that the insurance will operate as primary insurance and that no other insurance of the City's will be called upon to contribute to a loss hereunder. Contractor shall provide evidence of each insurance policy to the Department prior to the commencement of work under this Agreement.

Article 13. Conflict of Interest Contractor declares that it has no present interest, nor shall it acquire any interest, direct or indirect, which would conflict with the performance of Services under this Agreement. Contractor agrees that no person having any such interest shall be employed in the performance of this Agreement.

Article 14. Waiver No failure of either party to enforce a term of this Agreement against the other shall be construed as a waiver of that term, nor shall it in any way affect the party's right to enforce that term. No waiver by any party of any term of this Agreement shall be considered to be a waiver of any other term or breach thereof.

Article 15. Severability The invalidity, illegality or unenforceability of any provision of this Agreement or the occurrence of any event rendering any portion or provision of this Agreement void shall in no way affect the validity or enforceability of any other portion or provision of this Agreement. Any void provision shall be deemed severed from this Agreement, and the balance of the Agreement shall be construed and enforced as if it did not contain the particular provision to be held void. The parties further agree to amend this Agreement to replace any stricken provision with a valid provision that comes as close as possible to the intent of the stricken provision. The provisions of this Article shall not prevent this entire Agreement from being void should a provision which is of the essence of this Agreement be determined void.

Article 16. Assignment Neither the Department nor the Contractor shall assign any rights or duties under this Agreement without the prior written consent of the other party. Unless otherwise stated in the written consent to an assignment, no assignment will release or discharge the assignor from any obligation under this Agreement.

Article 17. Third Party Rights Nothing in this Agreement shall be construed to give any rights or benefits to anyone other than the parties.

Article 18. Governing Law and Venue This Agreement shall be governed by the laws of the State of Indiana. Venue of any disputes arising under this Agreement shall be in the Monroe Circuit Court, Monroe County, Indiana.

Article 19. Non-Discrimination Contractor shall comply with City of Bloomington Ordinance 2.21.020 and all other federal, state and local laws and regulations governing non-discrimination in all regards, including, but not limited to, employment. Contractor understands that the City of Bloomington prohibits its employees from engaging in harassment or discrimination of any kind, including harassing or discriminating against independent contractors doing work for the City. If the Contractor believes that a City employee engaged in such conduct towards Contractor and/or any of its employees, Contractor or its employees may file a complaint with the City department head in charge of the Contractor's work and/or with the City human resources department or the Bloomington Human Rights Commission. The City takes all complaints of harassment and discrimination seriously and will take appropriate disciplinary action if it finds that any City employee engaged in such prohibited conduct.

Article 20. Compliance with Laws In performing the Services under this Agreement, Contractor shall comply with any and all applicable federal, state and local statutes, ordinances, plans and regulations, including any and all regulations for protection of the environment. Where such statutes, ordinances, plans or regulations of any public authority having any jurisdiction over the project are in conflict, Contractor shall proceed using its best judgment only after attempting to resolve any such conflict between such governmental agencies, and shall notify the Department in a timely manner of the conflict, attempts of resolution, and planned course of action.

Article 21. E-Verify Contractor is required to enroll in and verify the work eligibility status of all newly-hired employees through the E-Verify program. (This is not required if the E-Verify program no longer exists). Contractor shall sign an affidavit, attached as Exhibit A, affirming that Contractor does not knowingly employ an unauthorized alien. Contractor shall require any subcontractors performing work under this contract to certify to the Contractor that, at the time of certification, the subcontractor does not knowingly employ or contract with an unauthorized alien and the subcontractor has enrolled in and is participating in the E-Verify program. Contractor shall maintain on file all subcontractors' certifications throughout the term of the contract with the City.

Article 22. Notices Any notice required by this Agreement shall be made in writing to the individuals/addresses specified below:

Department: City of Bloomington Public Works, Attn: Joe Van Deventer, 401 N. Morton, Suite 120, Bloomington, Indiana 47404.

Contractor: Precision Concrete, LLC, 1896 Goldeneye Drive, Holland, MI 49424.

Nothing contained in this Article shall be construed to restrict the transmission of routine communications between representatives of the Department and Contractor.

Article 23. Integration and Modification This Agreement, including all Exhibits incorporated by reference, represents the entire and integrated agreement between the Department and the Contractor. It supersedes all prior and contemporaneous communications, representations and agreements, whether oral or written, relating to the subject matter of this Agreement. This Agreement may be modified only by a written amendment signed by both parties hereto.

Article 24. Non-Collusion Contractor is required to certify that it has not, nor has any other member, representative, or agent of Contractor, entered into any combination, collusion, or agreement with any person relative to the price to be offered by any person nor prevented any person from making an offer nor induced anyone to refrain from making an offer and that this offer is made without reference to any other offer. Contractor shall sign an affidavit, attached hereto as Exhibit B, affirming that Contractor has not engaged in any collusive conduct. Exhibit B is attached hereto and incorporated by reference as though fully set forth.

Article 25. Living Wage Ordinance Contractors that are considered "covered employers" under City Ordinance 2.28, otherwise known as the "Living Wage Ordinance," or "LWO," are required to pay their covered employees at least a living wage. Currently, the living wage is \$15.75 per hour for covered employees, and up to 15% of that amount, or \$2.36, may be in the form the covered employer's contribution to health insurance available to the covered employee.

Contractor is determined to be a covered employer under the LWO. Contractor shall execute the Living Wage Ordinance Affidavit, attached as Exhibit C; shall abide by the LWO by paying their employees a living wage; and shall post the Living Wage Poster, provided by the City Legal Department, in areas frequented by their covered employees.

Article 26. Renewal This Agreement may be renewed for three additional one-year terms so long as none of the terms and conditions herein are modified in any way. Renewal shall only occur upon advanced written notice by the City to the Contractor that the City wishes to renew the Agreement at least thirty (30) days, but not more than sixty (60) days, prior to the end of the current term

CITY OF BLOOMINGTON

Precision Concrete, LLC

Margie Rice, Corporation Counsel

Bonnie K Bonkowski, Chief Financial Officer

CITY OF BLOOMINGTON PUBLIC WORKS

Adam Wason, Director

Kyla Cox Deckard, President, Board of Public Works

EXHIBIT B

STATE OF INDIANA)
) SS:
COUNTY OF _____)

NON-COLLUSION AFFIDAVIT

The undersigned offeror or agent, being duly sworn on oath, says that he has not, nor has any other member, representative, or agent of the firm, company, corporation or partnership represented by him, entered into any combination, collusion or agreement with any person relative to the price to be offered by any person nor to prevent any person from making an offer nor to induce anyone to refrain from making an offer and that this offer is made without reference to any other offer.

OATH AND AFFIRMATION

I affirm under the penalties of perjury that the foregoing facts and information are true and correct to the best of my knowledge and belief.

Dated this _____ day of _____, 20____.

Precision Concrete, LLC

By: _____

STATE OF INDIANA)
) SS:
COUNTY OF _____)

Before me, a Notary Public in and for said County and State, personally appeared _____ and acknowledged the execution of the foregoing this _____ day of _____, 2023.

Notary Public Printed Name

Notary Public's Signature

My Commission Expires: _____

County of Residence: _____

My Commission #: _____



Board of Public Works Staff Report

Project/Event: Renewal #2 Agreement for Sidewalk Assistance 50/50 Repair/Replacement Program

Petitioner/Representative: Street Department

Staff Representative: Joe Van Deventer

Meeting Date: February 13, 2024

On March 15, 2022, the Board of Public Works approved the 2022 Agreement with Groomer Construction, Inc. for Sidewalk Assistance 50/50 Repair/Replacement Program, as the lowest responsive and responsible quote. This Renewal #2 supplements that Sidewalk Assistance 50/50 Repair/Replacement Program with Groomer Construction, Inc. for 2024 as agreed by both City and Groomer Construction, Inc.

Groomer Construction, Inc. **\$ 100,000.00**

City of Bloomington Contract and Purchase Justification Form

Vendor: Groomer Construction, Inc.

Contract Amount: \$ 100,000

This form should be completed and attached to the contract documents and forwarded to the Legal Department Attorney assigned to your Department. Contracts will not be approved by the Controller if a completed form is not included with the contract documents.

PURCHASE INFORMATION

1. Check the box beside the procurement method used to initiate this procurement: (Attach a quote or bid tabulation if applicable)

<input type="checkbox"/> Request for Quote (RFQ)	<input type="checkbox"/> Request for Proposal (RFP)	<input type="checkbox"/> Sole Source	<input checked="" type="checkbox"/> Not Applicable (NA)
<input type="checkbox"/> Invitation to Bid (ITB)	<input type="checkbox"/> Request for Qualifications (RFQu)	<input type="checkbox"/> Emergency Purchase	

2. List the results of procurement process. Give further explanation where requested.

	Yes	No		Yes	No
# of Submittals:			Was the lowest cost selected? (If no, please state below why it was not.)	<input checked="" type="checkbox"/>	<input type="checkbox"/>
Met city requirements?	<input checked="" type="checkbox"/>	<input type="checkbox"/>			
Met item or need requirements?	<input checked="" type="checkbox"/>	<input type="checkbox"/>			
Was an evaluation team used?	<input type="checkbox"/>	<input checked="" type="checkbox"/>			
Was scoring grid used?	<input type="checkbox"/>	<input checked="" type="checkbox"/>			
Were vendor presentations requested?	<input type="checkbox"/>	<input type="checkbox"/>			

3. State why this vendor was selected to receive the award and contract:

On March 15, 2022, the Board of Public Works approved the 2022 Agreement with Groomer Construction, Inc. for Sidewalk Assistance 50/50 Repair/Replacement Program, as the lowest responsive and responsible quote. This Renewal #2 supplements that Sidewalk Assistance 50/50 Repair/Replacement Program with Groomer Construction, Inc. for 2024 as agreed by both City and Groomer Construction, Inc.

 Joe VanDeventer

Print/Type Name

 Director of Operations

Print/Type Title

 PW/Street Division

Department

**RENEWAL #2 TO AGREEMENT FOR SIDEWALK ASSISTANCE 50/50
REPAIR/REPLACEMENT PROGRAM**

Between the

CITY OF BLOOMINGTON

And

GROOMER CONSTRUCTION, INC.

In May of 2022, the Board of Public Works approved the 2022 Agreement with Groomer Construction, Inc., for Sidewalk Assistance 50/50 Repair/Replacement Program, as the lowest responsive and responsible bidder. This Renewal #2 supplements that Agreement for Sidewalk Assistance 50/50 Repair/Replacement Program with Groomer Construction, Inc. as follows:

1. **Article 25. Renewal** states the agreement maybe renewed for two additional one-year terms so long as noon of the terms and conditions herein are modified in anyway. Renewal shall only occur upon advanced written notice by the City to the Contractor that the City wishes to renew the Agreement at least thirty (30) days, but not more than sixty (60) days, prior to the end of the current term.
2. Groomer Construction, Inc. provided notice to the City on December 31, 2023 of its wish to renew this Agreement.
3. The City also wishes to renew this Agreement for 2024 Sidewalk Assistance 50/50 Repair/Replacement Program.
4. **Article 26. Living Wage Ordinance.** Contractor is considered a “covered employer” under City Ordinance 2.28, otherwise known as the “Living Wage Ordinance,” or “LWO,” and is required to pay their covered employees at least a living wage. Currently, the living wage is \$15.75 per hour for covered employees, and up to 15% of that amount, or \$2.36, may be in the form the covered employer’s contribution to health insurance available to the covered employee.
Contractor shall execute the Living Wage Ordinance Affidavit, attached as Exhibit C; shall abide by the LWO by paying their employees a living wage; and shall post the Living Wage Poster, provided by the City Legal Department, in areas frequented by their covered employees.
5. In all other respects, the Agreement shall remain in effect as originally written.

CITY OF BLOOMINGTON

GROOMER CONSTRUCTIONS, INC.

By: _____
Kyla Cox Deckard, President
Board of Public Works

By: _____
Richard Groomer, President

Date: _____

Date: _____

By: _____
Adam Wason, Director
Public Works Department

Date: _____

By: _____
Margie Rice, Corporation Counsel



Board of Public Works Staff Report

Project/Event: Renewal #2 Agreement for Sidewalk Repair/Replacement Services
Petitioner/Representative: Street Department
Staff Representative: Joe Van Deventer
Meeting Date: February 13, 2024

On May 24, 2022, the Board of Public Works approved the 2022 Agreement with Groomer Construction, Inc. for Sidewalk Repair/Replacement Services, as the lowest responsive and responsible bidder. This Renewal #2 supplements that Sidewalk Repair/Replacement Services with Groomer Construction, Inc. for 2024 as agreed by both City and Groomer Construction, Inc.

Groomer Construction, Inc. **\$ 200,000.00**

City of Bloomington Contract and Purchase Justification Form

Vendor: Groomer Construction, Inc.

Contract Amount: \$ 200,000

This form should be completed and attached to the contract documents and forwarded to the Legal Department Attorney assigned to your Department. Contracts will not be approved by the Controller if a completed form is not included with the contract documents.

PURCHASE INFORMATION

1. Check the box beside the procurement method used to initiate this procurement: (Attach a quote or bid tabulation if applicable)

<input type="checkbox"/> Request for Quote (RFQ)	<input type="checkbox"/> Request for Proposal (RFP)	<input type="checkbox"/> Sole Source	<input checked="" type="checkbox"/> Not Applicable (NA)
<input type="checkbox"/> Invitation to Bid (ITB)	<input type="checkbox"/> Request for Qualifications (RFQu)	<input type="checkbox"/> Emergency Purchase	

2. List the results of procurement process. Give further explanation where requested.

	Yes	No		Yes	No
# of Submittals:			Was the lowest cost selected? (If no, please state below why it was not.)	<input checked="" type="checkbox"/>	<input type="checkbox"/>
Met city requirements?	<input checked="" type="checkbox"/>	<input type="checkbox"/>			
Met item or need requirements?	<input checked="" type="checkbox"/>	<input type="checkbox"/>			
Was an evaluation team used?	<input type="checkbox"/>	<input checked="" type="checkbox"/>			
Was scoring grid used?	<input type="checkbox"/>	<input checked="" type="checkbox"/>			
Were vendor presentations requested?	<input type="checkbox"/>	<input type="checkbox"/>			

3. State why this vendor was selected to receive the award and contract:

On May 24 2022, the Board of Public Works approved the 2022 Agreement with Groomer Construction, Inc. for Sidewalk Services, as the lowest responsive and responsible quote. This Renewal #2 supplements that Sidewalk Services with Groomer Construction, Inc. for 2024 as agreed by both City and Groomer Construction, Inc.

 Joe VanDeventer

Print/Type Name

 Director of Operations

Print/Type Title

 PW/Street Division

Department

Groomer Construction, Inc.
Richard Groomer
6535 W. Ison Rd.
Bloomington, Indiana 47403
Ph# 812-825-2758
e-mail: groomconst2758@yahoo.com

Date: January 8,2024

To; Street Dept
1981 S. Henderson
Bloomington, Indiana 47401

To who it may concern Groomer Construction Inc will extend their contract for city Sidewalk Services for the 2024 year.

Thank You
Richard Groomer /President
Groomer Construction Inc.

Thank You,
Richard Groomer, President
Groomer Construction, Inc.

REGISTER OF PAYROLL CLAIMS
Board: Board of Public Works Claim Register

Date:	Type of Claim	FUND	Description	Bank Transfer	Amount
2/9/2024	Payroll				576,918.18
					<u>576,918.18</u>

ALLOWANCE OF CLAIMS

We have examined the claims listed on the foregoing register of claims, consisting of 1
claim, and except for the claims not allowed as shown on the register, such claims are hereby allowed in the
total amount of \$ 576,918.18

Dated this 13th day of February year of 2024.

Kyla Cox Deckard, President Elizabeth Karon, Vice President James Roach, Secretary

I hereby certify that each of the above listed voucher(s) or bill(s) is (are) true and correct and I have audited same in accordance with IC 5-11-10-1.6.

Fiscal Officer _____



Board of Public Works Staff Report

Project/Event:	Atlantic Engineering Group (AEG)
Staff Representative:	Alex Gray
Petitioner/Representative:	Bret Simons
Date:	February 13 th , 2024

Report: AEG is requesting lane closures and sidewalk closures in multiple locations of their project work areas. This request is to accommodate work on fiber installation via boring and aerial fiber installation. The traffic control will be in place after February 19th through the end of the project, which we're estimating to be 4 weeks per project area.

AEG has supplied various maintenance of traffic plans for all work. They are also placing door hangers for public notice to property owners about scope of their work and contact information for if there are any issues. (see packet for details).

AEG is requesting for 3 project areas to be granted through this BPW meeting. The following areas include...

N Crescent Rd	This will include underground fiber placement between W Gray St to W 17 th St and N Adams St to Highway 37/I-69. Work on N Crescent Rd and W Fountain Dr, primarily at the intersection and B-Line extension project work area, will be delayed until a later time and will be present in a separate permit.
N Pine St	This will include aerial and underground fiber placement between W Bloomfield Rd to W 9 th St and S Landmark Ave to E Elm St or S Walker St. Work on N Adams St will be in coordination with the sidewalk work the City's Project Managers will be overseeing this summer.
S Strong Dr	This will include aerial and underground fiber placement from W Countryside Ln neighborhoods north along S Rockport and S Rogers St to neighborhoods at S Patterson Dr and W Grimes Ln. Then the work continues north along S Patterson Dr to W Allen St and behind Catalent on Strong Dr.



P.O. Box 349 | Buford, Georgia 30515
Main Office: (706)654-2298
www.aeg.cc

To: City of Bloomington – Engineering Department
Subject: City of Bloomington Right of Way Application

Dear Board Members,

Atlantic Engineering Group is planning a large FTTH project across the entire City of Bloomington. This work will take place at different locations throughout the year. In order to facilitate these upcoming projects, AEG is respectfully requesting access to the ROW as planned out in the submitted permits.

Weekday hours will be from 8-4pm. Hours Saturday will be from 8-3pm. This will only be restoration, splicing and/or cable pulling. School zone hours will be from 8:30-2:30pm.

Traffic control plans will be attached to each permit. No long-term road closures or sidewalk closures are expected. Signs and flaggers will be present when needed and move with the project as it moves throughout the city. The areas will all be identified on the plans we submit to the city's Engineering Department.

Proper door hangers will be placed prior to the construction starting in a particular area. The door hangers will provide information about the construction and contact information if any issues arise.

Bret Simons
Engineering Project Coordinator
Atlantic Engineering Group



**Fiber Internet is coming
to Bloomington!**

You can subscribe now!

Get the Fastest Internet in Town

- ✓ Same Speeds Up and Down
- ✓ Ultimate Gaming with No Lag
- ✓ Stream without Buffering
- ✓ Video Chats without Interruption
- ✓ Use **All** Your Devices, **All** at the Same Time — No Problem!



GigabitNow
INDIANA

Internet How It Is Meant To Be

www.GigabitNowIndiana.com



Fiber Optic Internet is Coming to Your Neighborhood!

Over the next several weeks there will be construction crews in your area building a new fiber optic network. Fiber is the fastest and most reliable technology to deliver internet and Wi-Fi services.

Before we begin building, we must determine the location of existing underground utilities.

Construction areas will be marked with flags and paint that should remain in place for the duration of construction.

Please feel free to mark any private underground facilities that you believe are in the right of way. Examples of private facilities are: Sprinkler systems, dog fences, private gas line, pool systems, etc..

For additional information please call
1-800-315-3509



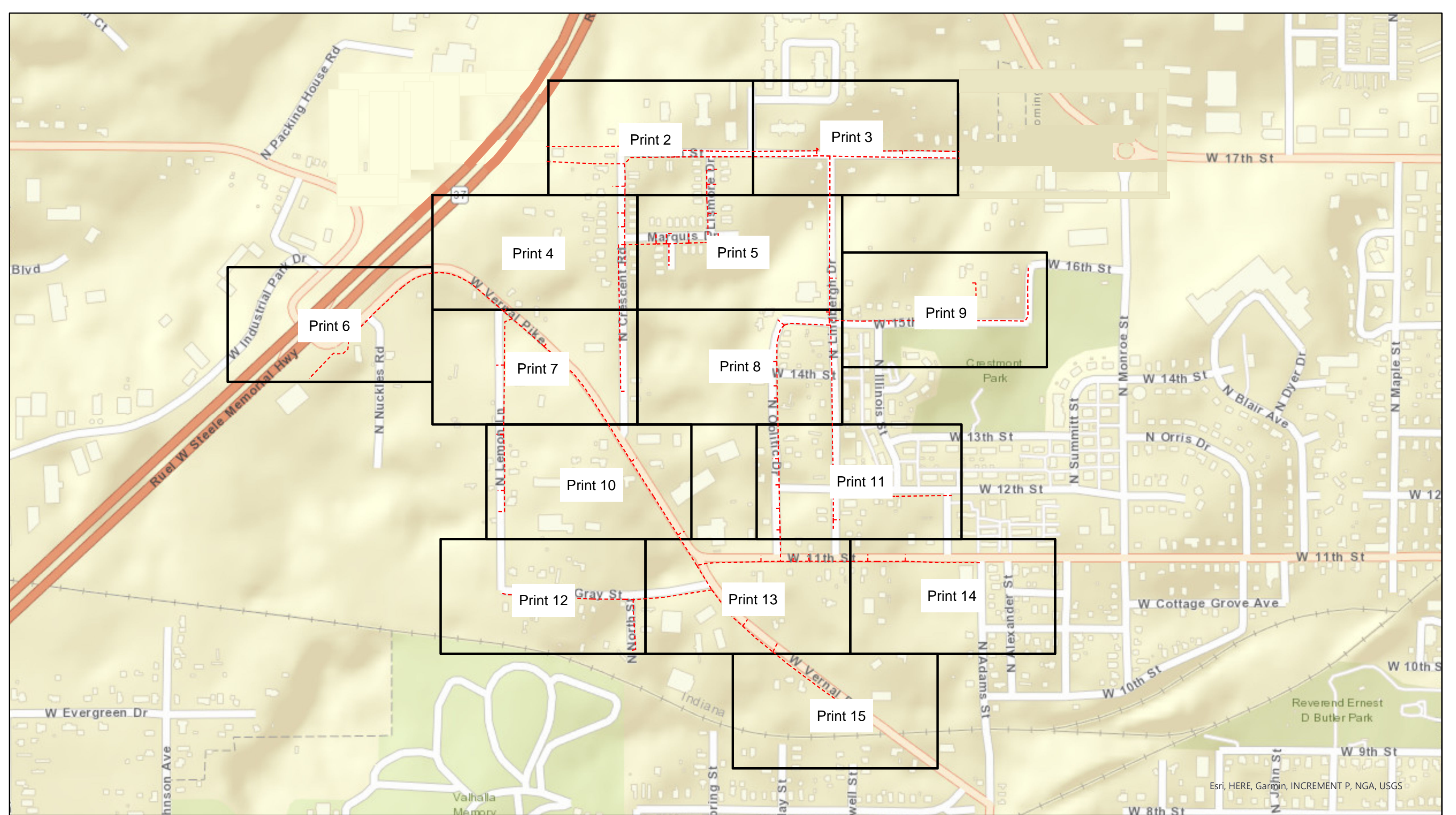

Esri, HERE, Garmin, INCREMENT P, NGA, USGS



Legend BLN01b-F13_N Crescent Rd

- Overhead Strand
- - - Conduit
- Grids



City of Bloomington, IN Permit:
Design View

INI	BY	DATE	DESCRIPTION

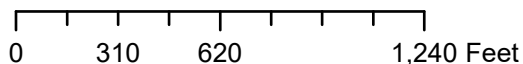

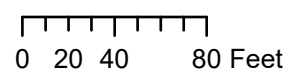
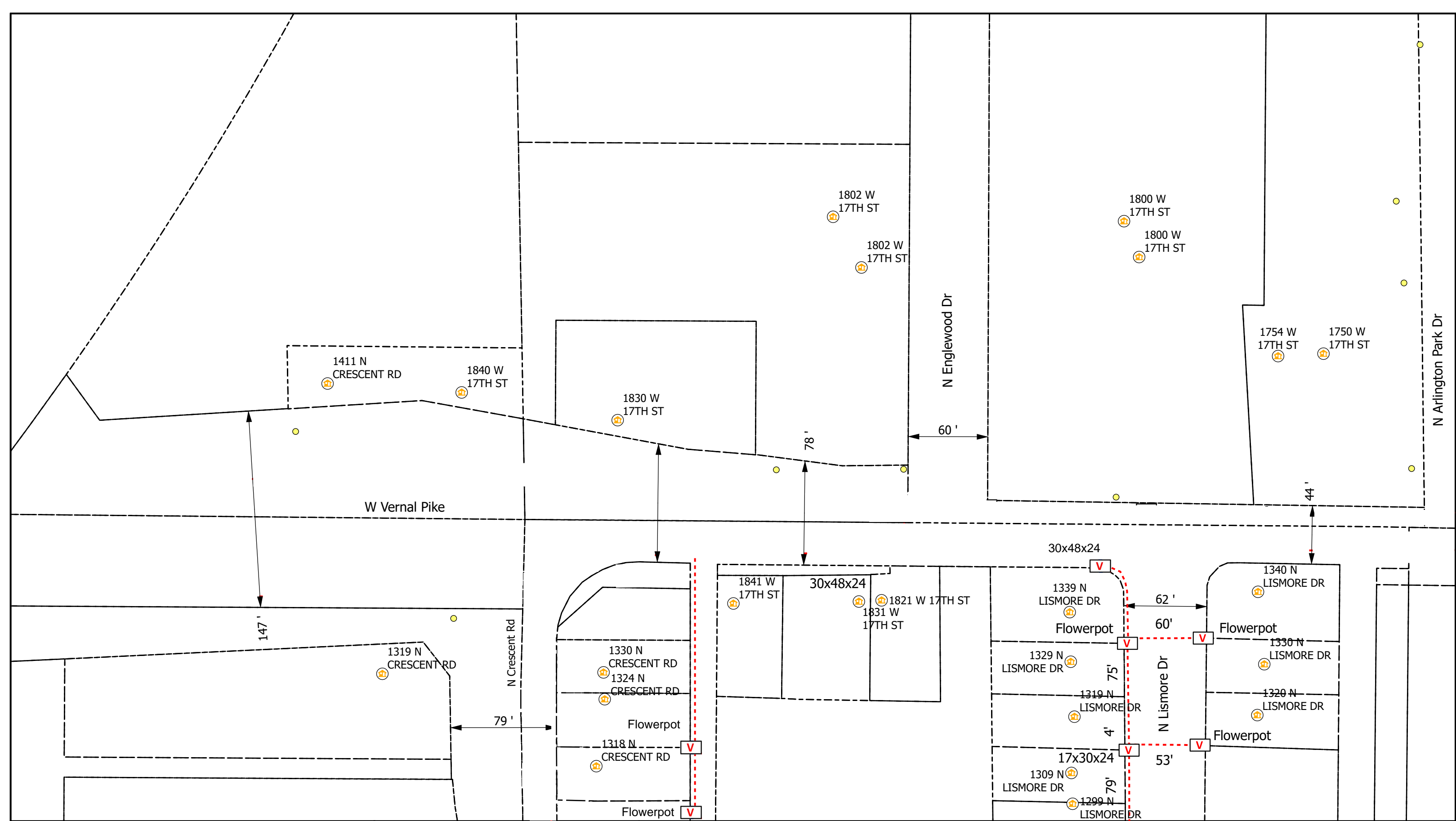

Legend

- Poles
- Vaults
- Overhead Strand
- Conduit
- Risers
- Address
- Anchor
- Sidewalk
- Bloomington_Parcels
- Grids

All Flowerpots 12" DIA



City of Bloomington, IN Permit:
Design View

INI	BY	DATE	DESCRIPTION



1488 N ARLINGTON PARK DR
 1488 N ARLINGTON PARK DR
 1488 N ARLINGTON PARK DR

1320 N ARLINGTON PARK DR
 1342 N ARLINGTON PARK DR

1342 N ARLINGTON PARK DR
 1330 N ARLINGTON PARK DR
 1330 N ARLINGTON PARK DR

1330 N ARLINGTON PARK DR
 1330 N ARLINGTON PARK DR
 1330 N ARLINGTON PARK DR

1600 W 17TH ST

1220 N ARLINGTON PARK DR
 1220 N ARLINGTON PARK DR
 1222 N ARLINGTON PARK DR
 1222 N ARLINGTON PARK DR
 1220 N ARLINGTON PARK DR
 1220 N ARLINGTON PARK DR
 1220 N ARLINGTON PARK DR
 1222 N ARLINGTON PARK DR
 1222 N ARLINGTON PARK DR
 1222 N ARLINGTON PARK DR

1604 W 17TH ST

1504 W 17TH ST

1412 W 17TH ST

1408 W 17TH ST

Continues into BLN01b-F12_W 17th St

W 17th St

1261 N LINDBERGH DR

1611 W 17TH ST

224'

Flowerpot

N Lindbergh Dr

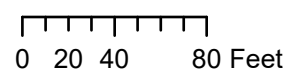

Legend

- Poles
- Vaults
- Overhead Strand
- Conduit
- Risers
- Address
- Anchor
- Sidewalk
- Bloomington_Parcels
- Grids

All Flowerpots 12" DIA



City of Bloomington, IN Permit:
Design View

INI	BY	DATE	DESCRIPTION



Ruel W Steele Memorial Hwy

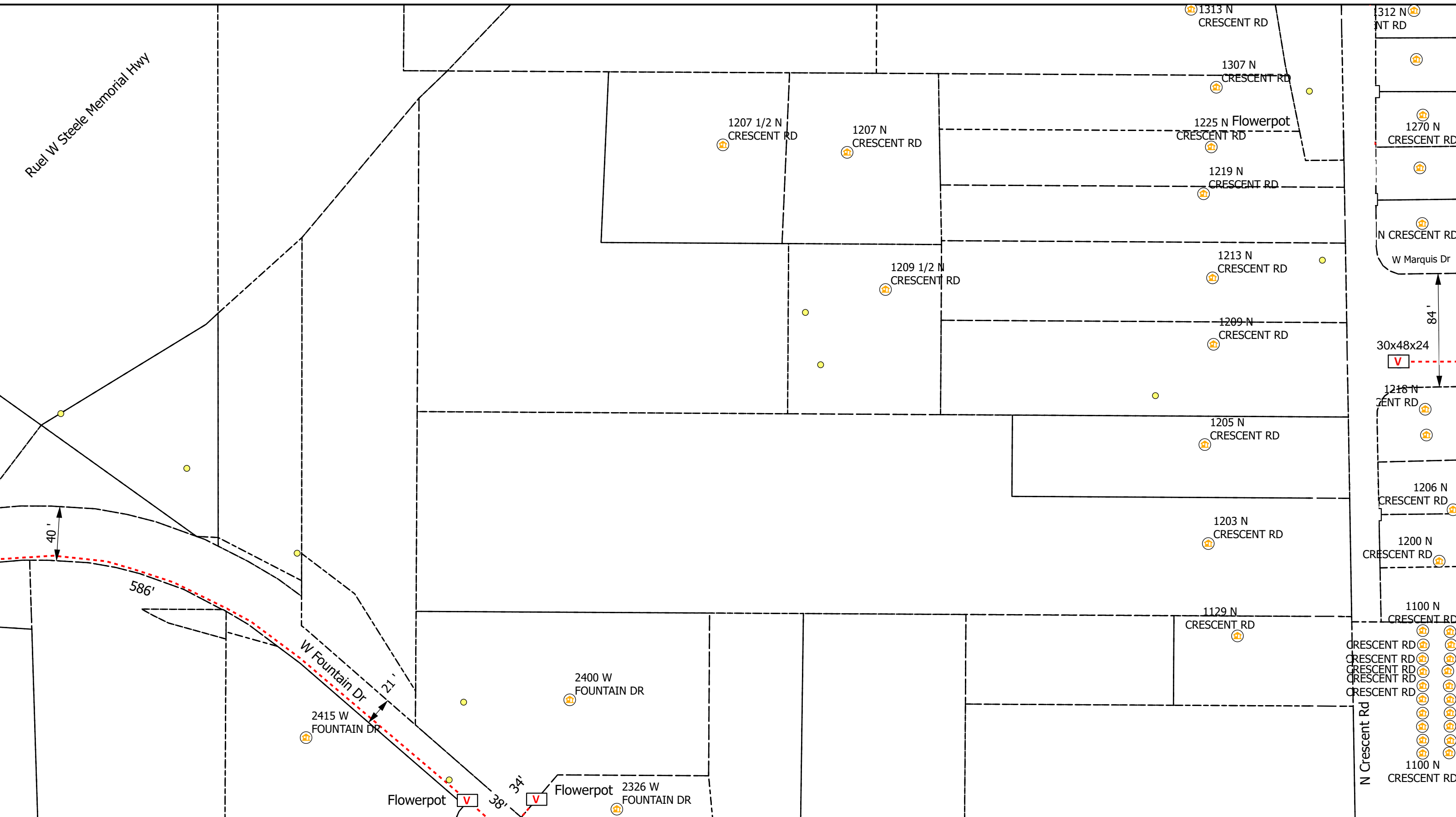

Legend

- Poles
- V Vaults
- Overhead Strand
- - - Conduit
- Ⓡ Risers
- Ⓜ Address
- Y Anchor
- └ Sidewalk
- Bloomington_Parcels
- Grids

All Flowerpots 12" DIA



City of Bloomington, IN Permit:
Design View

INI	BY	DATE	DESCRIPTION



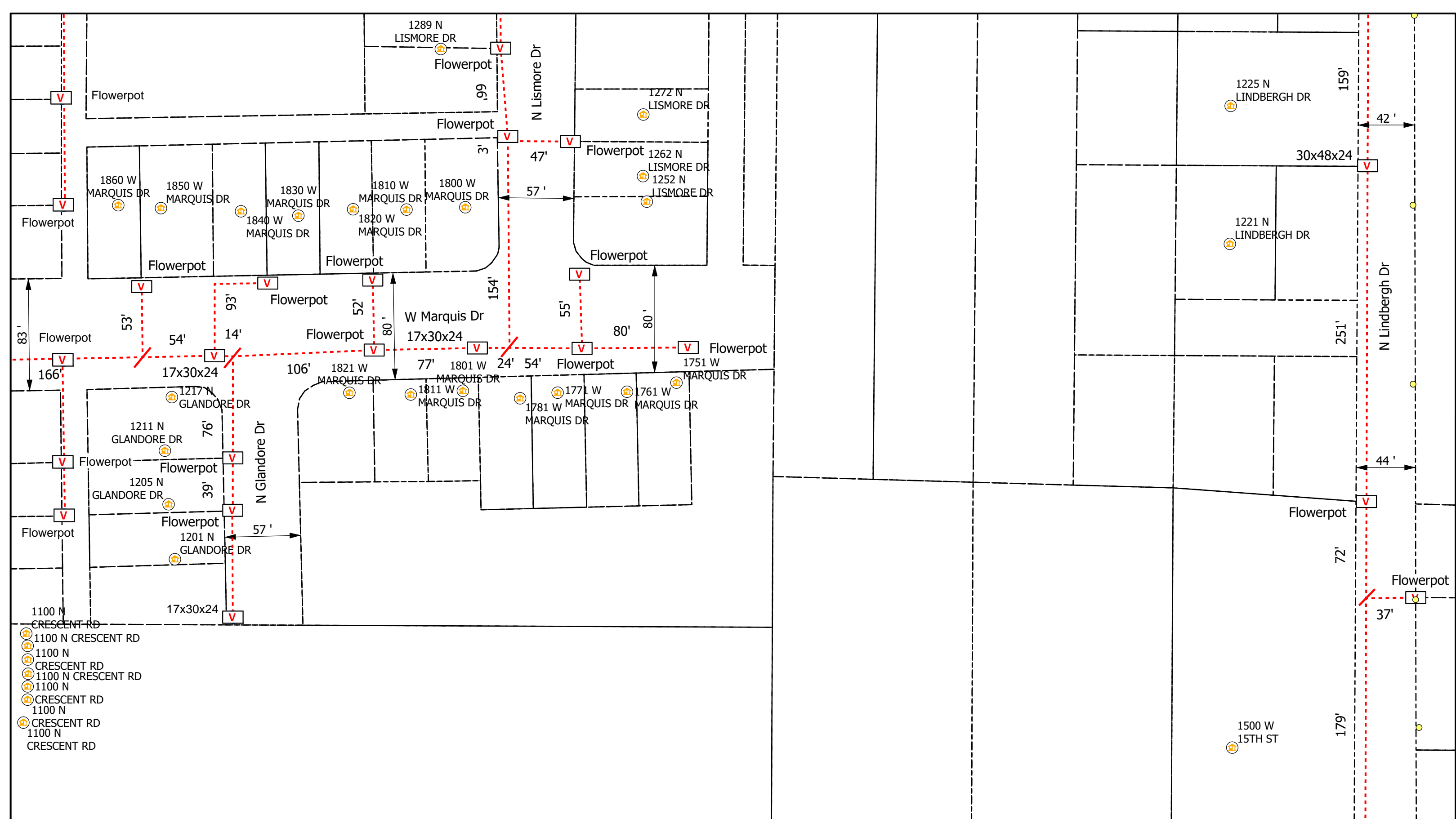

0 20 40 80 Feet

Legend

- Poles
- Ⓡ Risers
- ↖ Sidewalk
- Ⓟ Vaults
- 🏠 Address
- ❏ Bloomington_Parcels
- Overhead Strand
- Y Anchor
- Grids
- - - Conduit

All Flowerpots 12" DIA

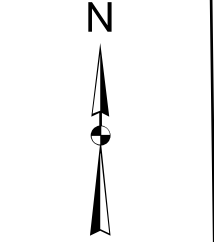

City of Bloomington, IN Permit:
Design View

INI	BY	DATE	DESCRIPTION

Print 5 of 15

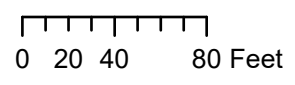
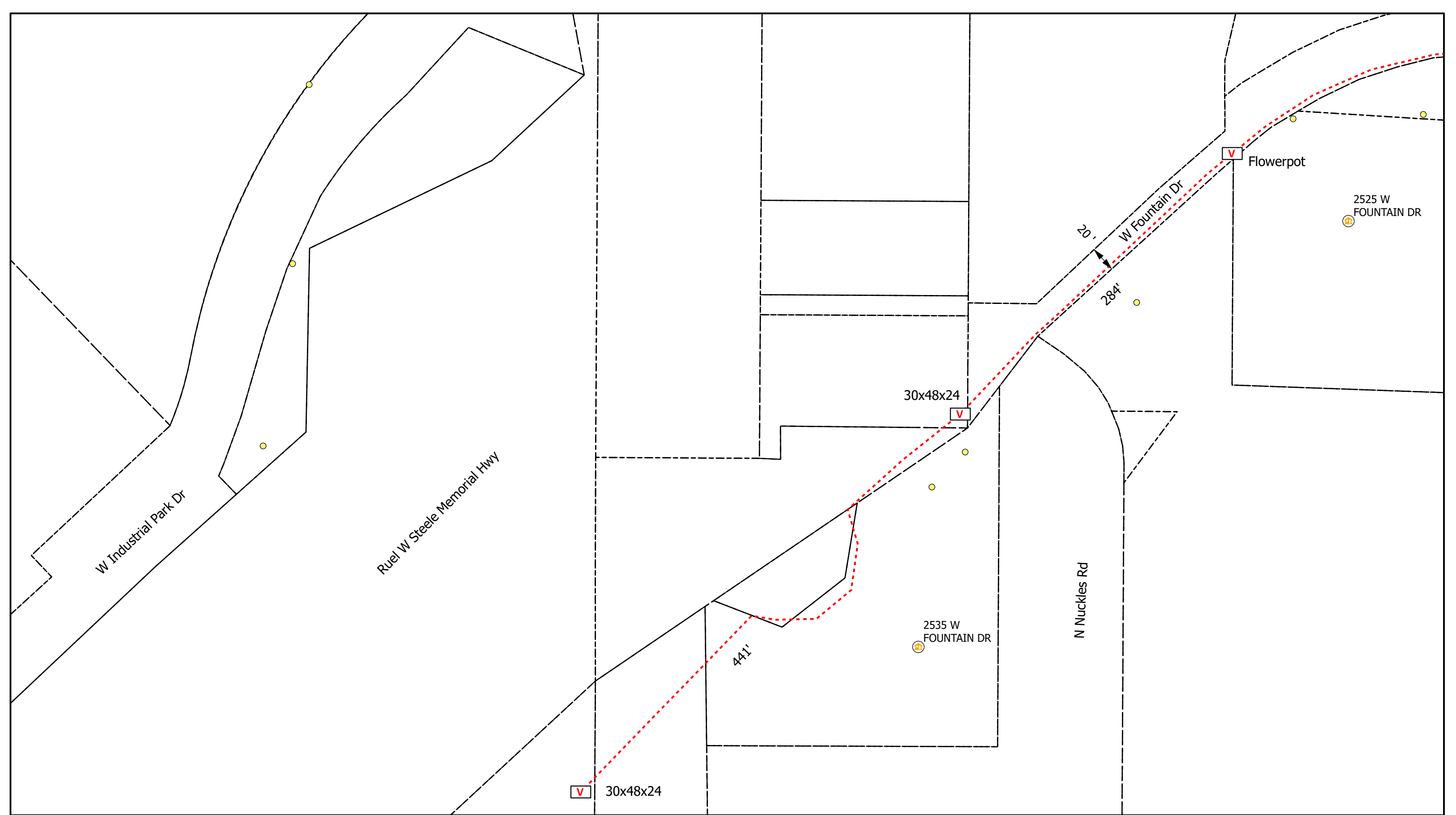

Legend

- Poles
- V Vaults
- Overhead Strand
- - - Conduit
- R Risers
- A Address
- Y Anchor
- └─┘ Sidewalk
- Bloomington_Parcels
- Grids

All Flowerpots 12" DIA



City of Bloomington, IN Permit:
Design View

INI	BY	DATE	DESCRIPTION



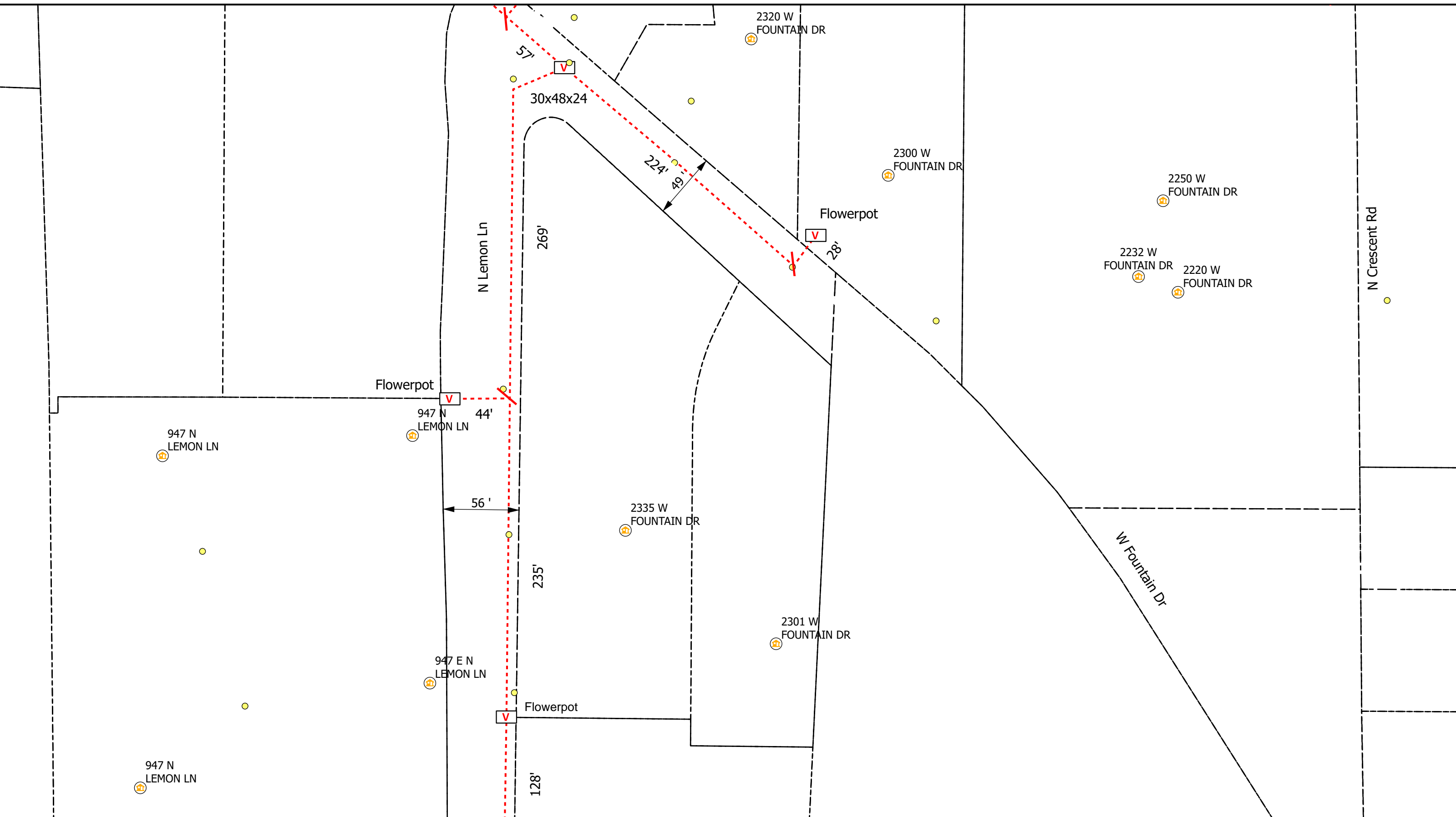

- Legend**
- Poles
 - V Vaults
 - Overhead Strand
 - Conduit
 - R Risers
 - A Address
 - Y Anchor
 - └─┘ Sidewalk
 - Bloomington_Parcels
 - Grids

All Flowerpots 12" DIA



City of Bloomington, IN Permit:
Design View

INI	BY	DATE	DESCRIPTION



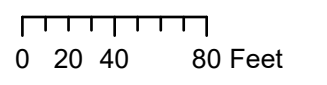
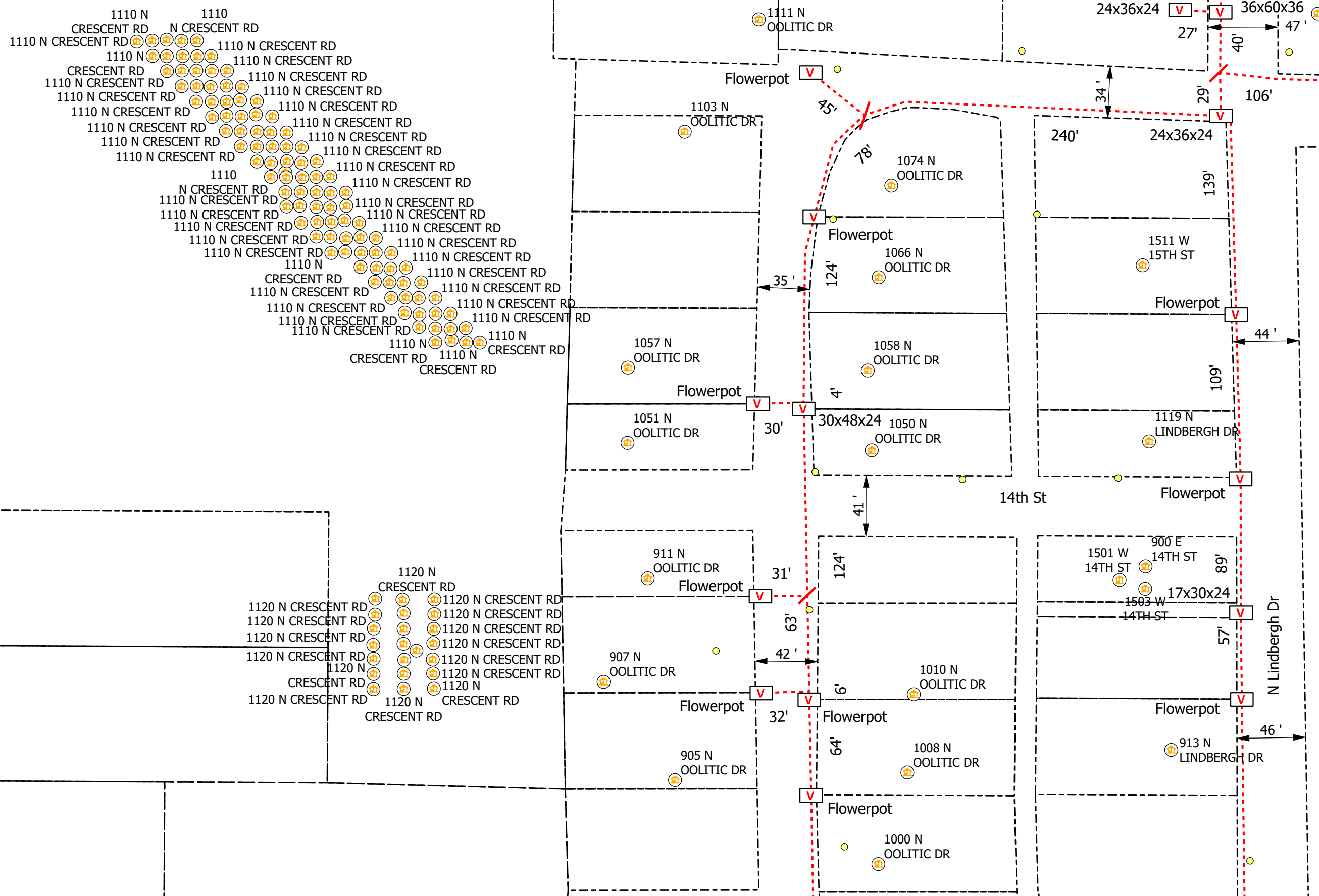

Legend

- Poles
- Ⓡ Risers
- Ⓜ Sidewalk
- V Vaults
- Overhead Strand
- Bloomington_Parcels
- Conduit
- Y Anchor
- Grids

All Flowerpots 12" DIA



City of Bloomington, IN Permit:
Design View

INI	BY	DATE	DESCRIPTION



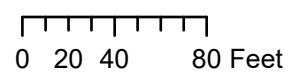
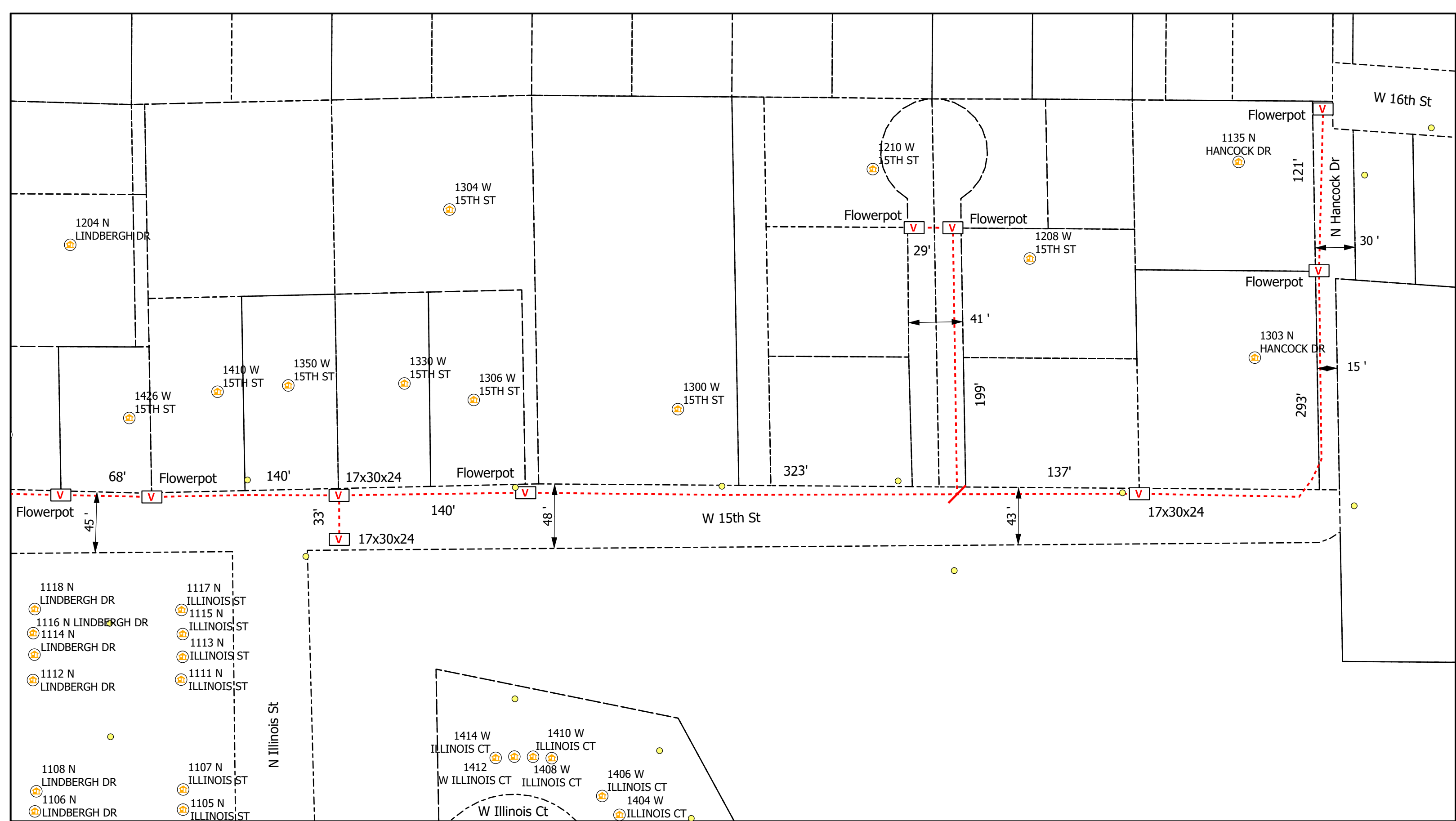

Legend

- Poles
- Ⓡ Risers
- Ⓜ Sidewalk
- V Vaults
- Ⓜ Address
- Bloomington_Parcels
- Overhead Strand
- Y Anchor
- - - Conduit
- Grids

All Flowerpots 12" DIA



City of Bloomington, IN Permit:
Design View

INI	BY	DATE	DESCRIPTION



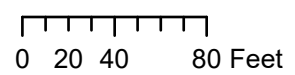
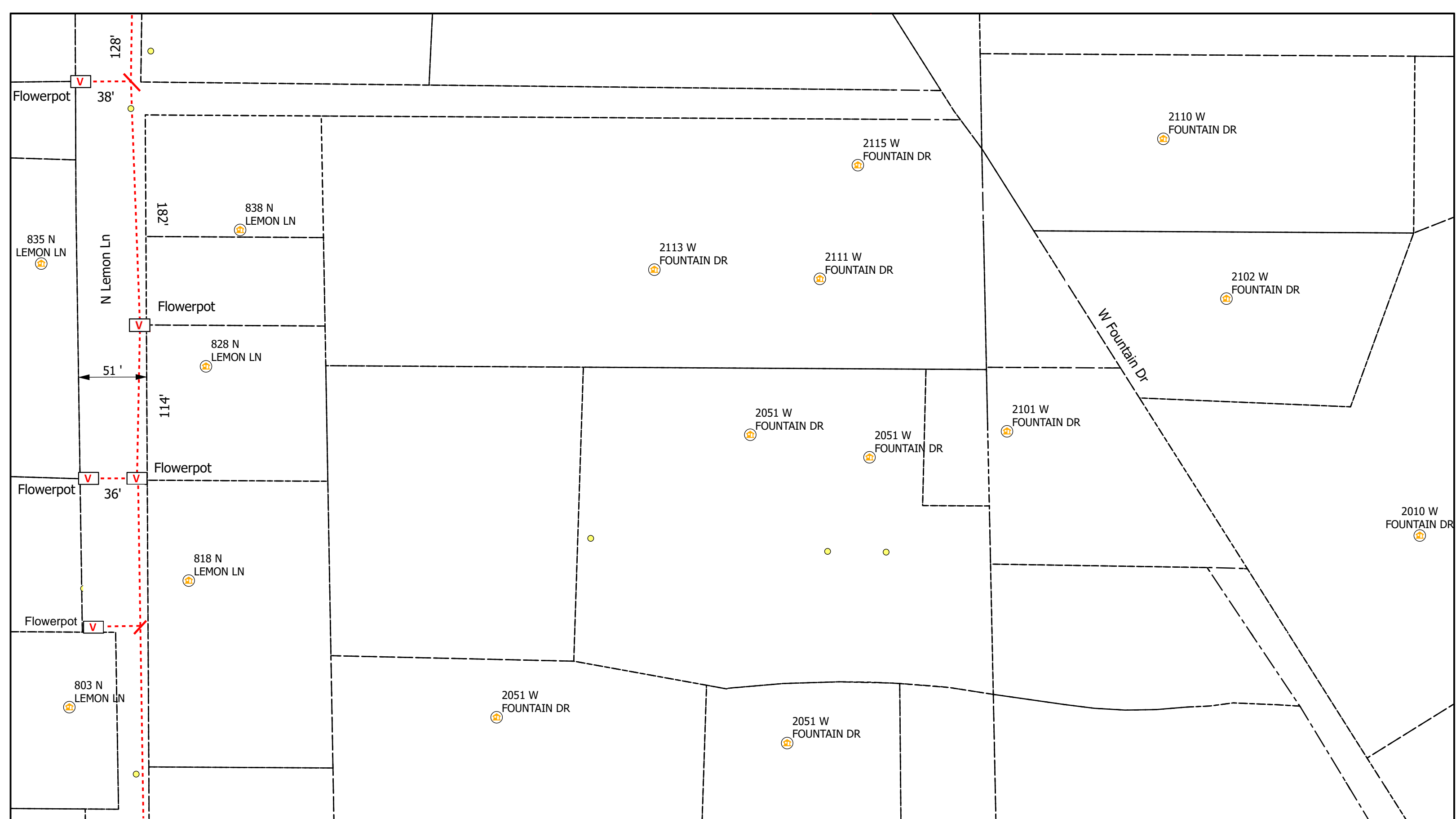

Legend

- Poles
- Ⓡ Risers
- Ⓜ Sidewalk
- V Vaults
- 🏠 Address
- Bloomington_Parcels
- Overhead Strand
- Conduit
- Y Anchor
- Grids

All Flowerpots 12" DIA



City of Bloomington, IN Permit:
Design View

INI	BY	DATE	DESCRIPTION



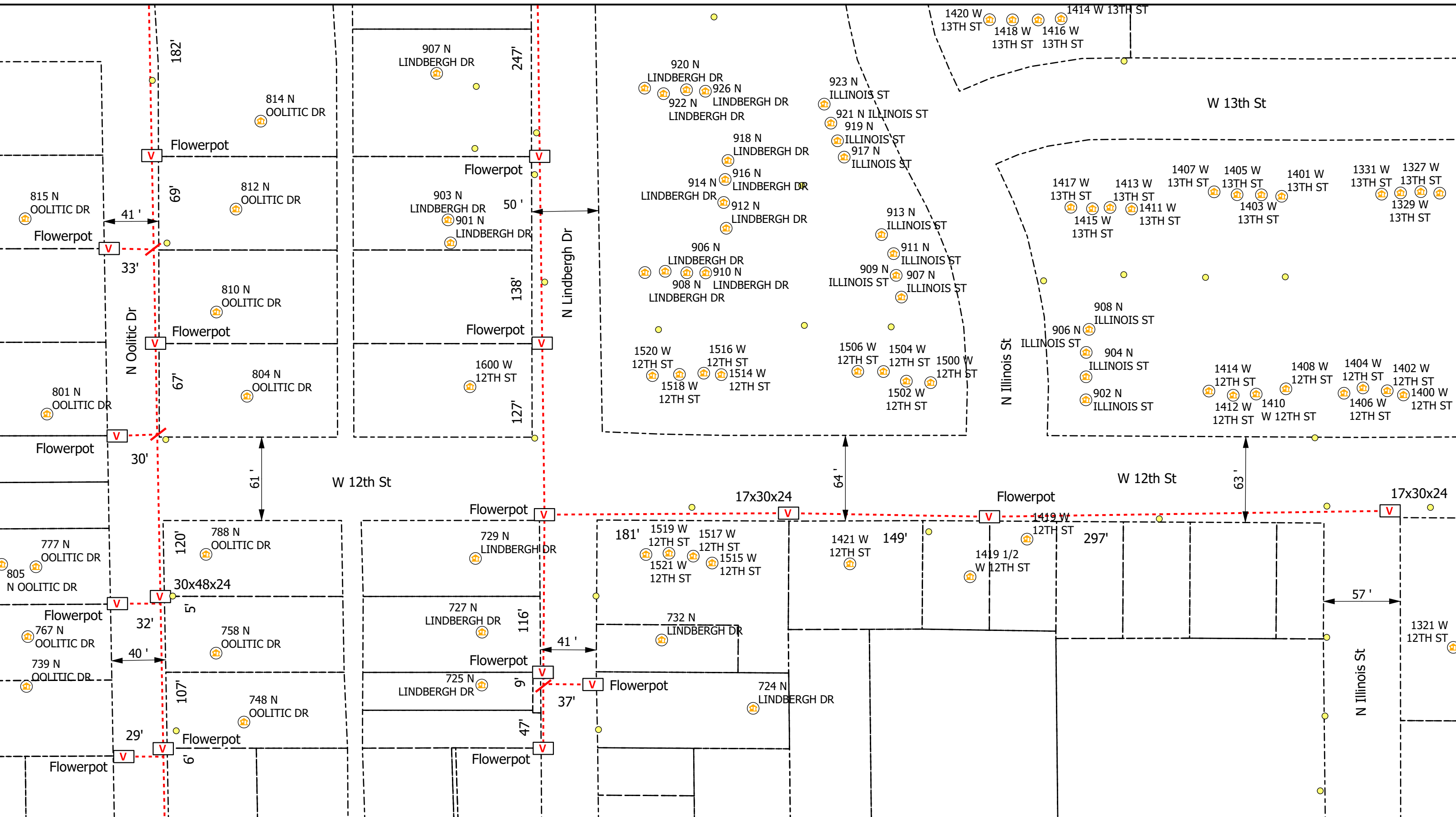

0 20 40 80 Feet

Legend

- Poles
- V Vaults
- Overhead Strand
- - - Conduit
- R Risers
- Ⓜ Address
- Y Anchor
- ↖ Sidewalk
- Bloomington_Parcels
- Grids

All Flowerpots 12" DIA

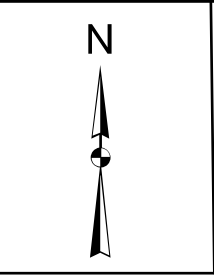

City of Bloomington, IN Permit:
Design View

INI	BY	DATE	DESCRIPTION

Print 11 of 15



0 20 40 80 Feet

Legend

- Poles
- Risers
- Sidewalk
- Vaults
- Address
- Bloomington_Parcels
- Overhead Strand
- Conduit
- Anchor
- Grids

All Flowerpots 12" DIA

N



City of Bloomington, IN Permit:
Design View

INI	BY	DATE	DESCRIPTION

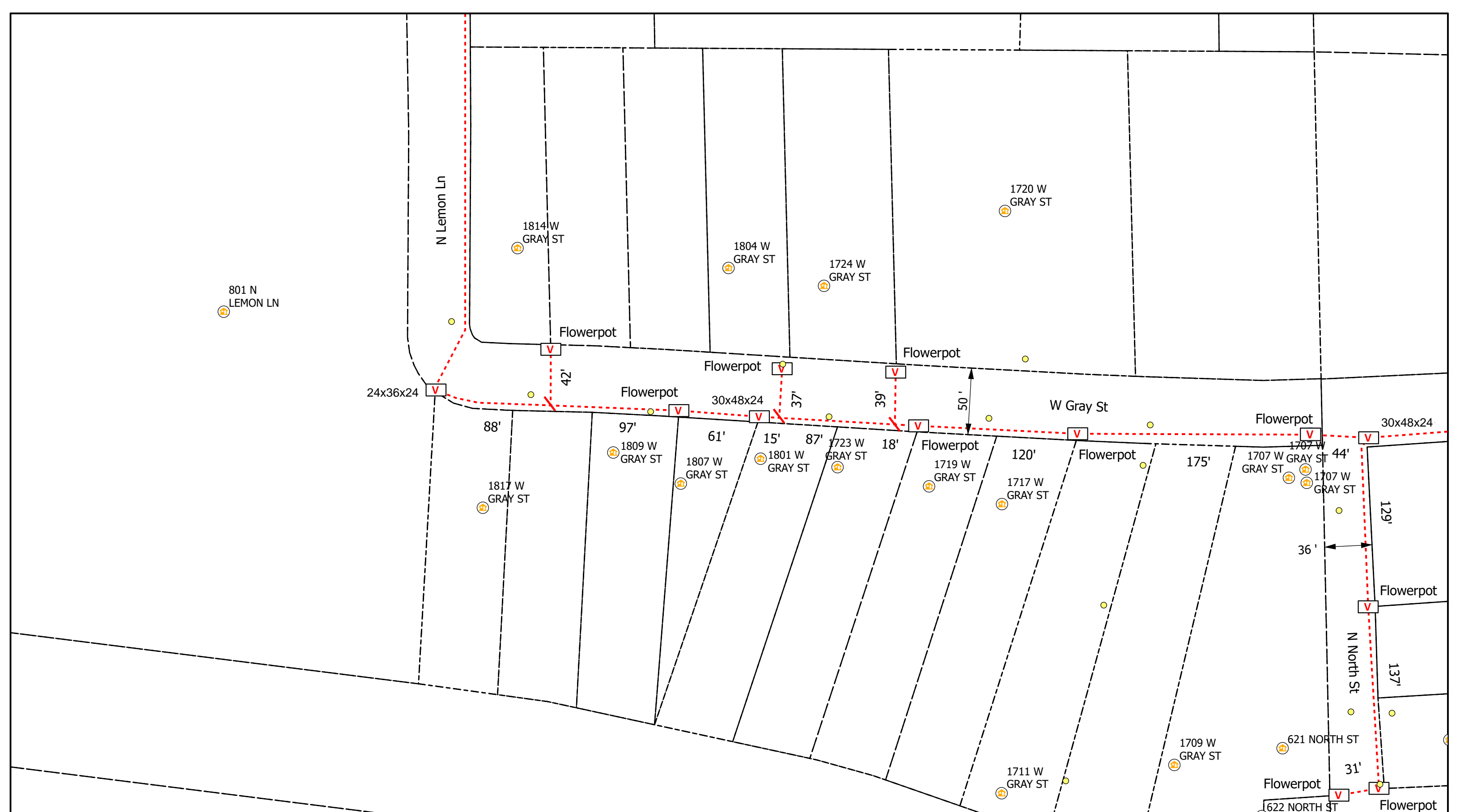

Vault might be in the dig path for some drainage work. Wait for coordination with crew completing the path extension project.

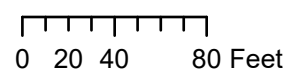
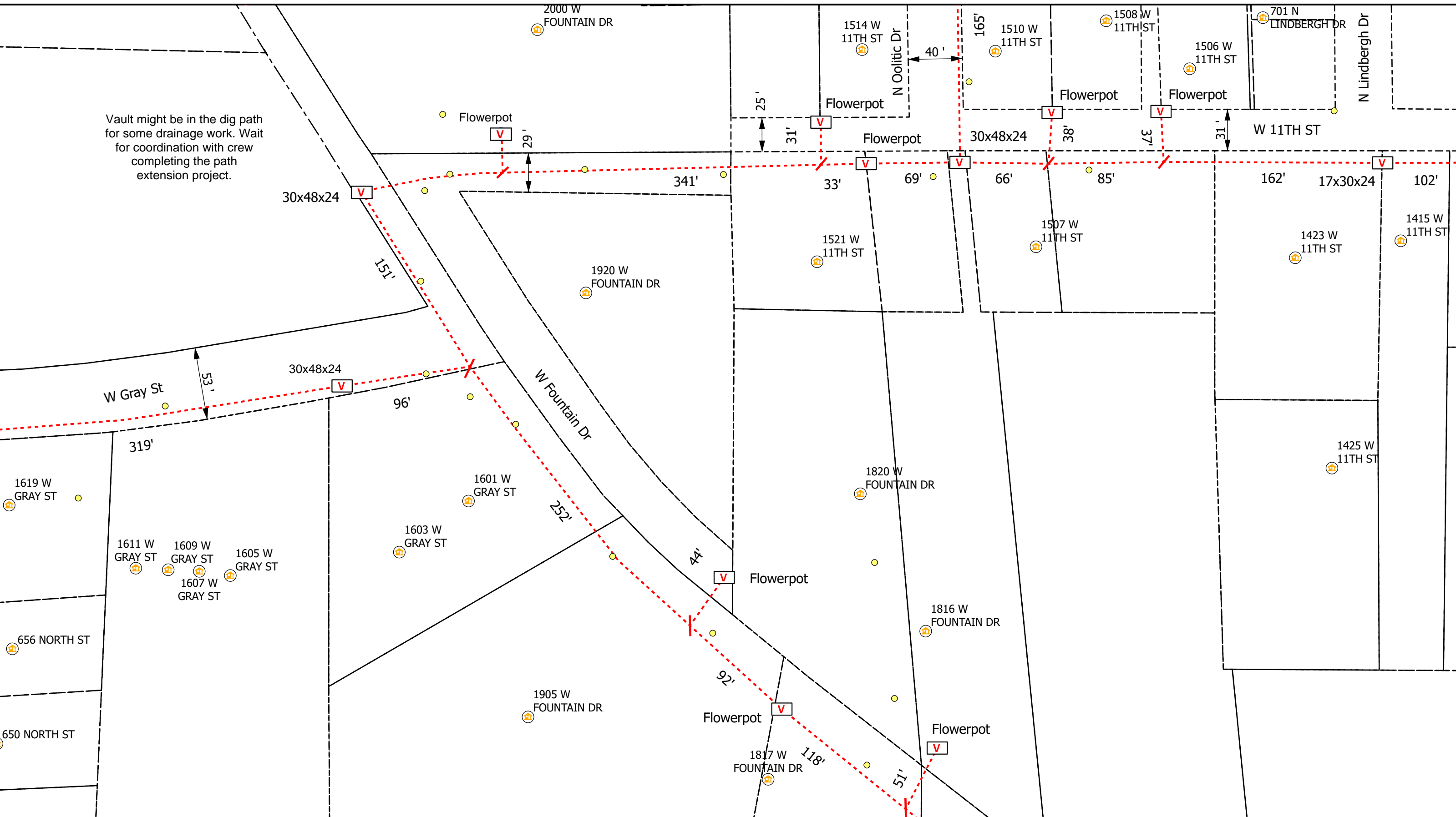

Legend

- Poles
- Ⓡ Risers
- V Vaults
- Overhead Strand
- Conduit
- Ⓜ Address
- Y Anchor
- ↖ Sidewalk
- Bloomington_Parcels
- Grids

All Flowerpots 12" DIA



City of Bloomington, IN Permit:
Design View

INI	BY	DATE	DESCRIPTION



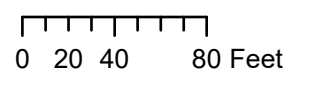
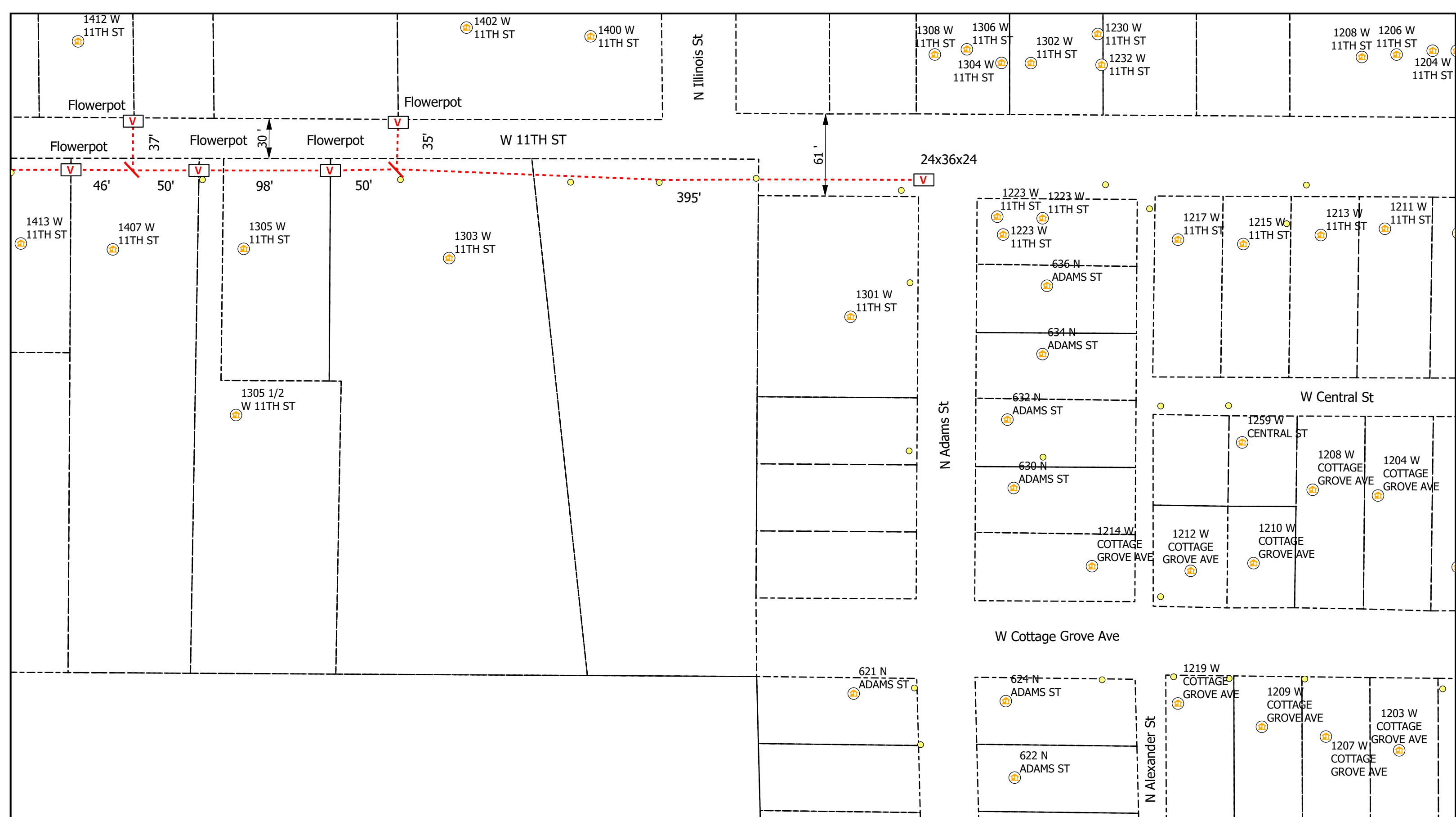

Legend

- Poles
- V Vaults
- Overhead Strand
- Conduit
- R Risers
- 🏠 Address
- Y Anchor
- ↖ Sidewalk
- Bloomington_Parcels
- Grids

All Flowerpots 12" DIA



City of Bloomington, IN Permit:
Design View

INI	BY	DATE	DESCRIPTION



1600 W FOUNTAIN DR

17x30x24

1803 W FOUNTAIN DR

444'

46'

Flowerpot

W Fountain Dr

Vault might be in the dig path for some drainage work. Wait for coordination with crew completing the path extension project.

1634 W 8TH ST
1630 W 8TH ST

425 N HAY ST

N Hay St

428 N HAY ST

424 N HAY ST

420 N HAY ST

429 N HOPEWELL ST

N Hopewell St

430 N HOPEWELL ST

420 N HOPEWELL ST

1313 W FOUNTAIN DR

1309 W FOUNTAIN DR

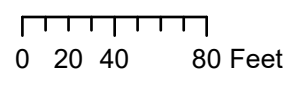

Legend

- Poles
- Vaults
- Overhead Strand
- Conduit
- Risers
- Address
- Anchor
- Sidewalk
- Bloomington_Parcels
- Grids

All Flowerpots 12" DIA



City of Bloomington, IN Permit:
Design View

INI	BY	DATE	DESCRIPTION



CONCEPTUAL SIDE VIEW

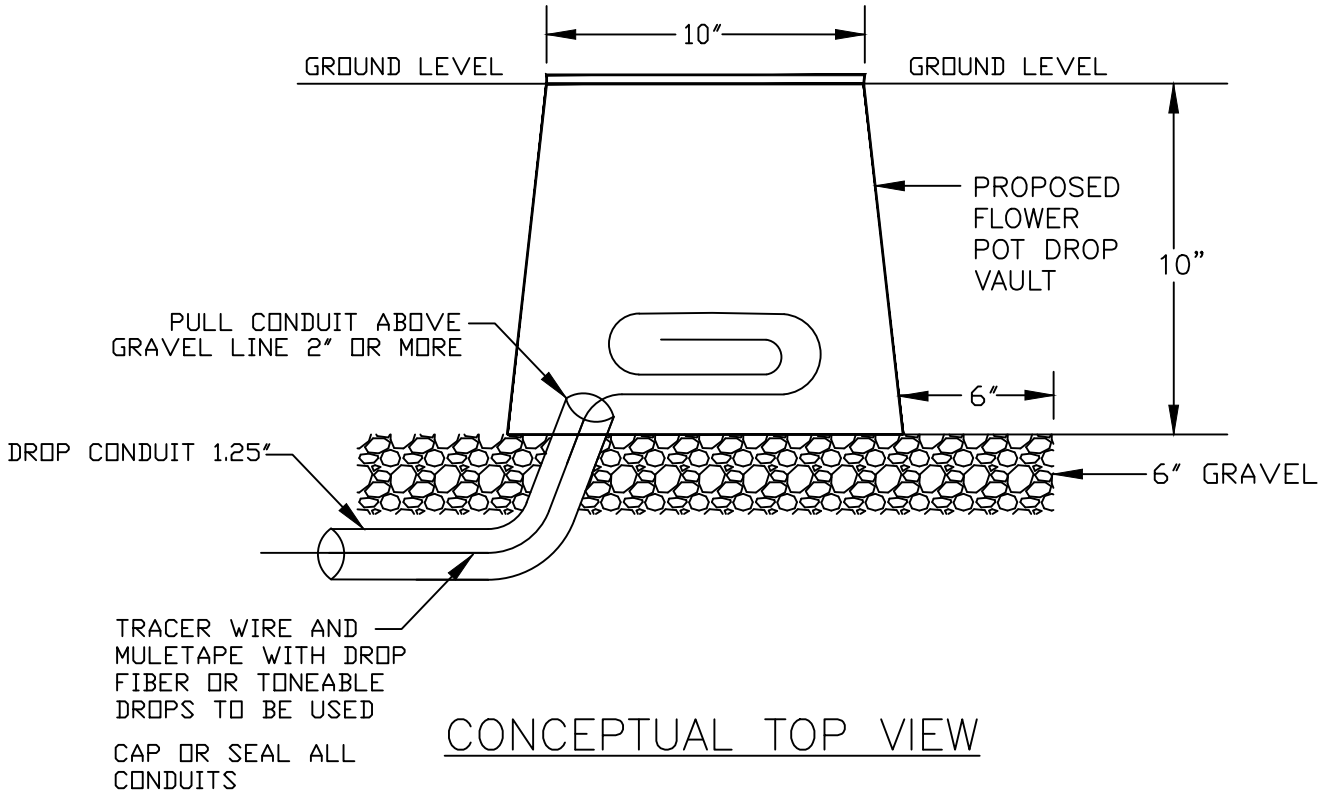

CONCEPTUAL TOP VIEW

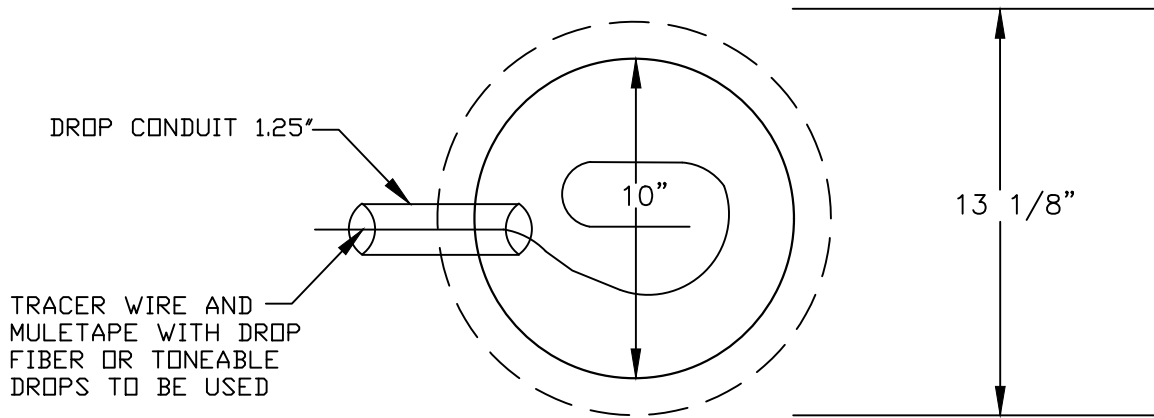

FLOWER POT

30"x48" PC UNIT, 2PC TIER 15/22
 18", 24", and 36" HEIGHT



AMERICAN POLYMER COMPANY

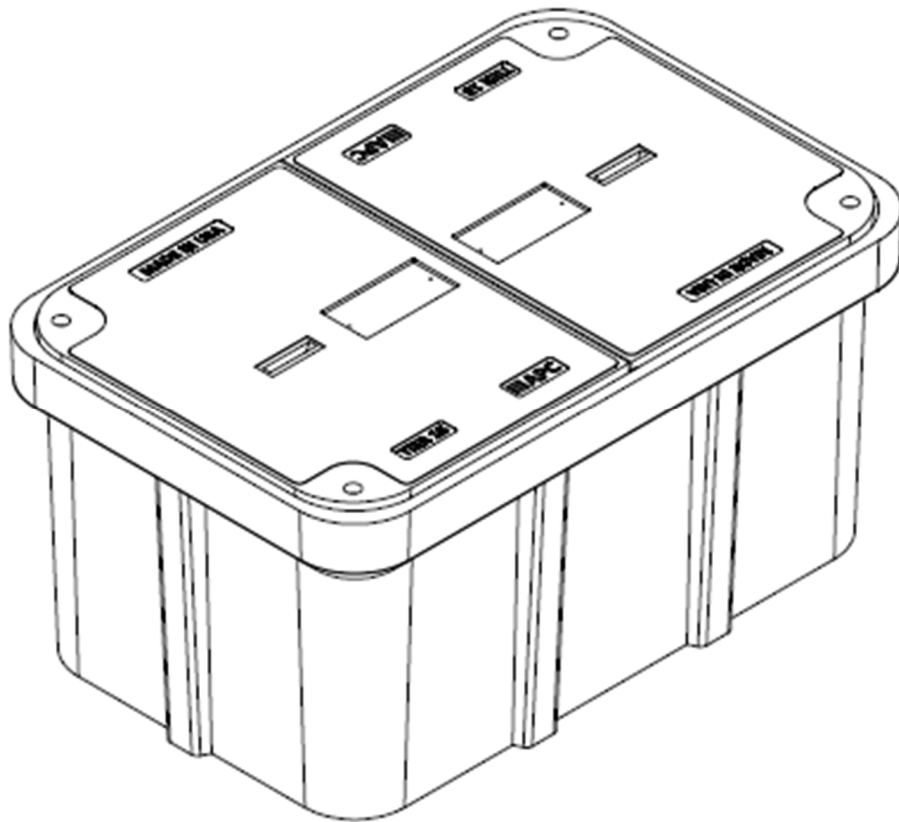

Description	Nominal Size	ANSI Tier	Part Number	Estimated Weight
PC Unit – TIER 15	30"x48"x18"	Tier 15	P304818HU15...	460 lbs.
PC Unit – TIER 22	30"x48"x18"	Tier 22	P304818HU22...	525 lbs.
PC Unit – TIER 15	30"x48"x24"	Tier 15	P304824HU15...	510 lbs.
PC Unit – TIER 22	30"x48"x24"	Tier 22	P304824HU22...	575 lbs.
PC Unit – TIER 15	30"x48"x36"	Tier 15	P304836HU15...	615 lbs.
PC Unit – TIER 22	30"x48"x36"	Tier 22	P304836HU22...	680 lbs.



30"x48" PC UNIT, 2PC TIER 15/22

18", 24", and 36" HEIGHT



AMERICAN POLYMER COMPANY

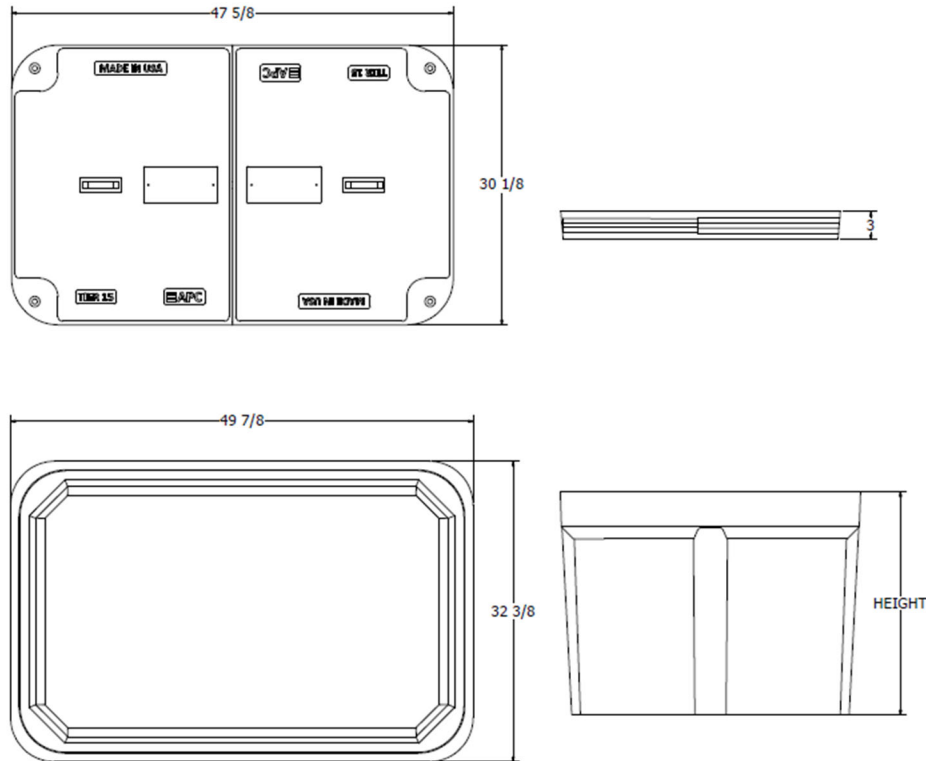

Components	Nominal Size	ANSI Tier	Part Number	Estimated Weight
Replacement Box	30"x48"x18"	Tier 22	P304818B22	185 lbs.
Replacement Box	30"x48"x24"	Tier 22	P304824B22	235 lbs.
Replacement Box	30"x48"x36"	Tier 22	P304836B22	340 lbs.
Replacement Lids - T15	30"x48" (half)	Tier 15	Various	150 lbs.
Replacement Lids - T22	30"x48" (half)	Tier 22	Various	170 lbs.

Bolt options



Machine Thread



Auger Thread



24"x36" PC UNIT, TIER 15/22
 18", 24", 30", and 36" HEIGHT



AMERICAN POLYMER COMPANY

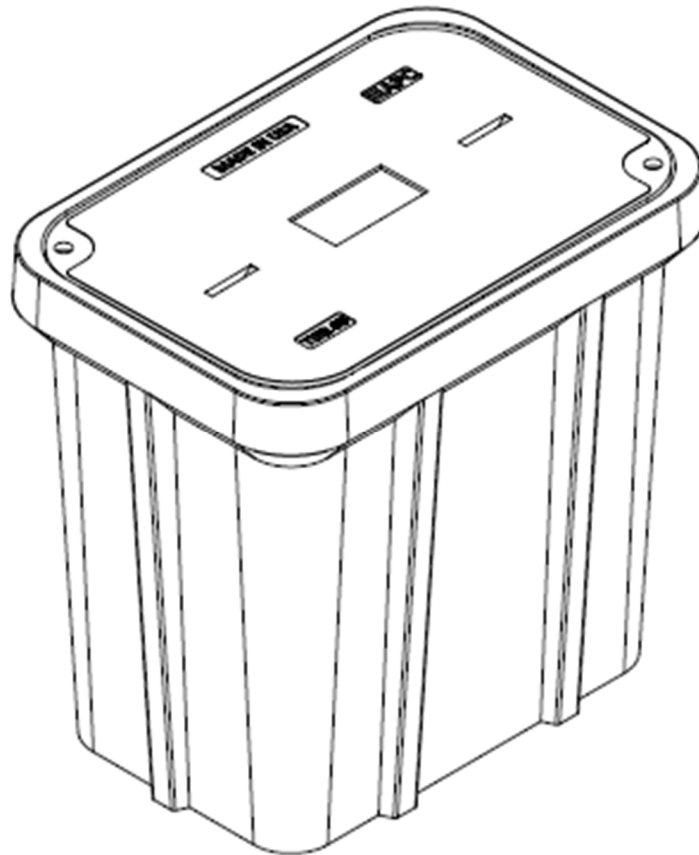

Description	Nominal Size	ANSI Tier	Part Number	Estimated Weight
PC Unit – TIER 15	24x36"x18"	Tier 15	P243618U15...	335 lbs.
PC Unit – TIER 22	24x36"x18"	Tier 22	P243618U22...	355 lbs.
PC Unit – TIER 15	24x36"x24"	Tier 15	P243624U15...	365 lbs.
PC Unit – TIER 22	24x36"x24"	Tier 22	P243624U22...	385 lbs.
PC Unit – TIER 15	24x36"x30"	Tier 15	P243630U15...	395 lbs.
PC Unit – TIER 22	24x36"x30"	Tier 22	P243630U22...	415 lbs.
PC Unit – TIER 15	24x36"x36"	Tier 15	P243636U15...	425 lbs.
PC Unit – TIER 22	24x36"x36"	Tier 22	P243636U22...	445 lbs.



24"x36" PC UNIT, TIER 15/22

18", 24", 30", and 36" HEIGHT



AMERICAN POLYMER COMPANY

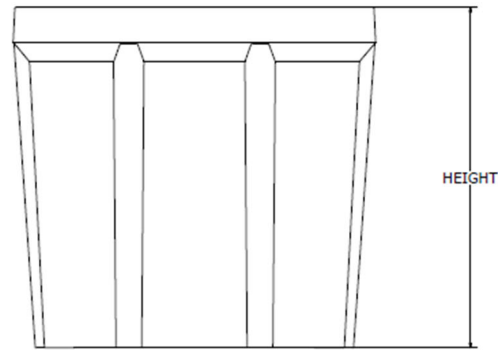
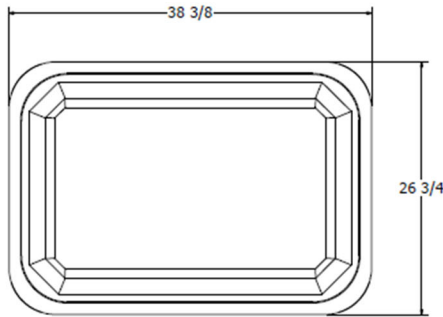
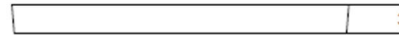
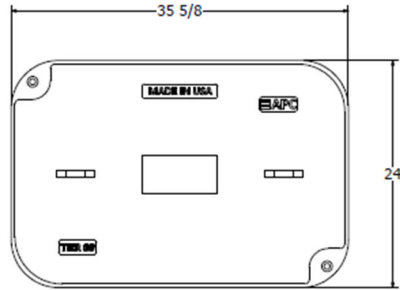

Components	Nominal Size	ANSI Tier	Part Number	Estimated Weight
Replacement Box	24"x36"x18"	Tier 22	P243618B22	165 lbs.
Replacement Box	24"x36"x24"	Tier 22	P243624B22	195 lbs.
Replacement Box	24"x36"x30"	Tier 22	P243630B22	225 lbs.
Replacement Box	24"x36"x36"	Tier 22	P243636B22	255 lbs.
Replacement Lids - T15	24"x36"	Tier 15	Various	170 lbs.
Replacement Lids - T22	24"x36"	Tier 22	Various	190 lbs.

Bolt options

Hex Head



Machine Thread



Penta Head



Auger Thread



17"x30" PC UNIT, TIER 15/22

12", 18", 24", and 30" HEIGHT



AMERICAN POLYMER COMPANY

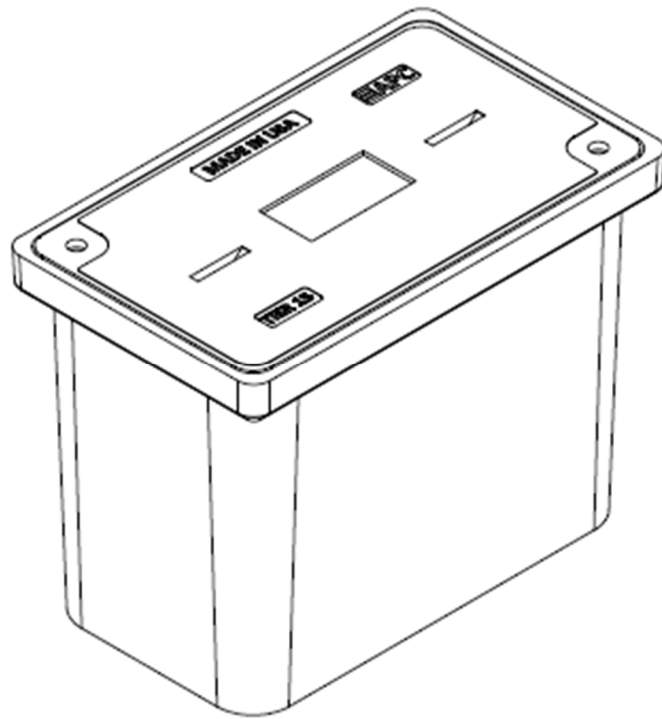

Description	Nominal Size	ANSI Tier	Part Number	Estimated Weight
PC Unit – TIER 15	17"x30"x12"	Tier 15	P173012U15...	138 lbs.
PC Unit – TIER 22	17"x30"x12"	Tier 22	P173012U22...	147 lbs.
PC Unit – TIER 15	17"x30"x18"	Tier 15	P173018U15...	172 lbs.
PC Unit – TIER 22	17"x30"x18"	Tier 22	P173018U22...	181 lbs.
PC Unit – TIER 15	17"x30"x24"	Tier 15	P173024U15...	192 lbs.
PC Unit – TIER 22	17"x30"x24"	Tier 22	P173024U22...	201 lbs.
PC Unit – TIER 15	17"x30"x30"	Tier 15	P173030U15...	217 lbs.
PC Unit – TIER 22	17"x30"x30"	Tier 22	P173030U22...	226 lbs.



17"x30" PC UNIT, TIER 15/22

12", 18", 24", and 30" HEIGHT



AMERICAN POLYMER COMPANY

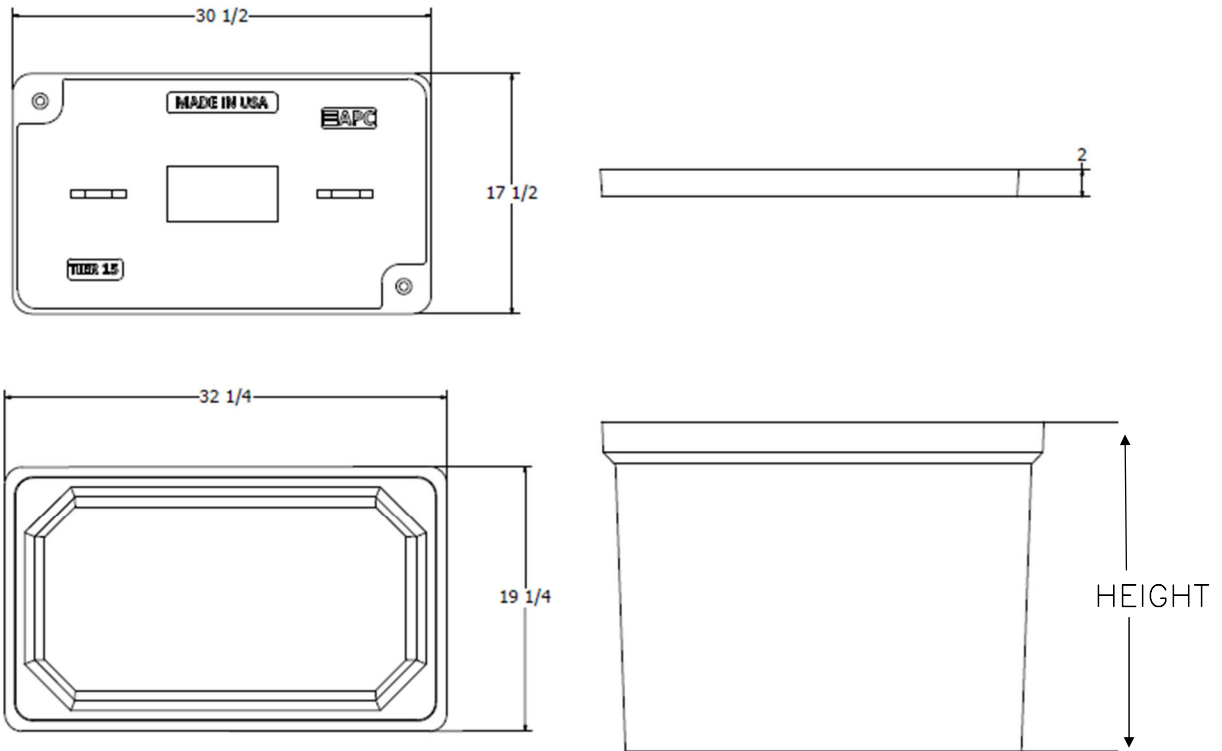

Components	Nominal Size	ANSI Tier	Part Number	Estimated Weight
Replacement Box	17"x30"x12"	Tier 22	P173012B22	66 lbs.
Replacement Box	17"x30"x18"	Tier 22	P173018B22	100 lbs.
Replacement Box	17"x30"x24"	Tier 22	P173024B22	120 lbs.
Replacement Box	17"x30"x30"	Tier 22	P173030B22	145 lbs.
Replacement Lids – T15	17"x30"	Tier 15	Various	72 lbs.
Replacement Lids – T22	17"x30"	Tier 22	Various	81 lbs.

Bolt options



Machine Thread



Auger Thread



33"x60" PC UNIT, 2PC TIER 15/22
36" HEIGHT



AMERICAN POLYMER COMPANY

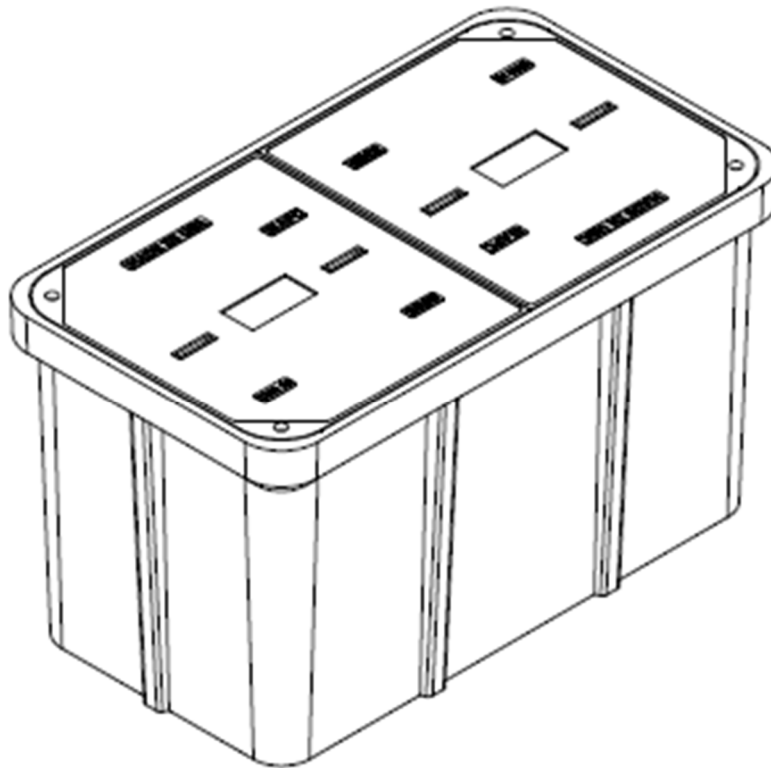

Description	Nominal Size	ANSI Tier	Part Number	Estimated Weight
PC Unit - TIER 15	33"x60"x36"	Tier 15	P336036U15...	930 lbs.
PC Unit - TIER 22	33"x60"x36"	Tier 22	P336036U22...	1030 lbs.



33"x60" PC UNIT, 2PC TIER 15/22

36" HEIGHT



AMERICAN POLYMER COMPANY

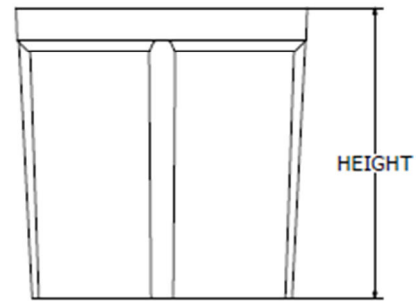
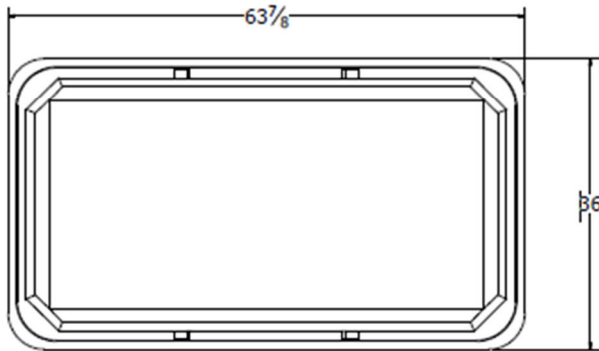
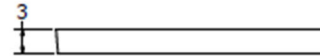
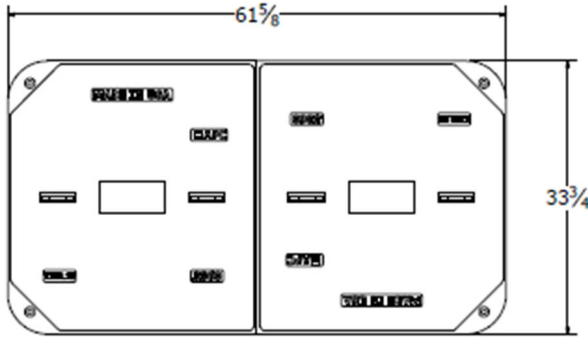

Components	Nominal Size	ANSI Tier	Part Number	Estimated Weight
Replacement Box	33"x60"x36"	Tier 22	P336036B22	530 lbs.
Replacement Lids - T15	33"x60" (half)	Tier 15	Various	200 lbs.
Replacement Lids - T22	33"x60" (half)	Tier 22	Various	250 lbs.

Bolt options

Hex Head



Machine Thread



Penta Head



Auger Thread





CITY OF BLOOMINGTON RIGHT-OF-WAY USE PERMIT APPLICATION

401 N Morton Street, Suite 130
P.O. Box 100
Bloomington, IN 47402

Phone: (812) 349-3913
Fax: (812) 349-3520
Email:
engineering@bloomington.in.gov

ROW EXCAVATION ROW USE

ADDRESS OF ROW ACTIVITY: BLN01b-F13_N Crescent Rd

A. APPLICANT/AGENT INFORMATION:		D. TRAFFIC CONTROL DEVICES*:	
APPLICANT NAME: <u>Bret Simons</u>		<input checked="" type="checkbox"/> CONES <input type="checkbox"/> ARROWBOARD	
E-MAIL: <u>bret.simons@aeg.cc</u>		<input type="checkbox"/> LIGHTED BARRELS <input checked="" type="checkbox"/> TYPE 3 BARRICADES	
COMPANY: <u>Atlantic Engineering Group</u>		<input checked="" type="checkbox"/> FLAGGERS <input type="checkbox"/> BPD OFFICER	
ADDRESS: <u>P.O. Box 349</u>		*PROVIDING MUTCD COMPLIANT TEMPORARY TRAFFIC CONTROL DEVICES AND MAINTENANCE OF TRAFFIC (MOT) PLAN IS YOUR RESPONSIBILITY AND REQUIRED. See page 3 for additional MOT resources; the graph paper can be used for your MOT site plan if needed or you can submit a separate sheet	
CITY, STATE, ZIP: <u>Buford, GA 30515</u>		E. METERED PARKING SPACES NEEDED: <input type="checkbox"/> Y <input type="checkbox"/> N	
24-HR EMERGENCY CONTACT NAME: <u>(706)654-2298</u>		IT IS THE RESPONSIBILITY OF THE APPLICANT TO RESERVE PARKING METER(S) APPLICATION LOCATED: https://bloomington.in.gov/transportation/parking/moving OR CONTACT PARKING SERVICES WITH QUESTIONS AT (812)349-3436	
24-HR CONTACT PHONE #: _____		F. IS THIS A <input type="checkbox"/> CBU* <input type="checkbox"/> COUNTY* <input type="checkbox"/> IU* <input type="checkbox"/> NP* PROJECT?	
INSURANCE #*: <u>TB5-691-473497-082</u> COMPANY: <u>ACORD</u>		PROJECT NAME: <u>BLN01b-F13 N Crescent Rd</u>	
BOND #*: <u>1160465</u> COMPANY: <u>LEXON</u>		PROJECT #: <u>BLN01b-F13 N Crescent Rd</u>	
*INSURANCE & BOND MUST BE ON FILE WITH THE CITY BEFORE PERMIT WILL BE ISSUED		PROJECT MGR.: <u>Patrick Brigman</u>	
SUBCONTRACTOR INFORMATION		PROJECT MGR. #: <u>215-847-8819</u>	
(LIST ALL COMPANIES WORKING UNDER PRIMARY CONTRACTOR PERMIT)		*CBU = CITY OF BLOOMINGTON UTILITIES *COUNTY = MONROE COUNTY	
COMPANY NAME: _____		*IU = INDIANA UNIVERSITY *NP = NOT-FOR-PROFIT AGENCY	
B. WORK DESCRIPTION:		G. EXCAVATIONS:	
<input type="checkbox"/> POD/DUMPSTER <input type="checkbox"/> CRANE <input type="checkbox"/> SCAFFOLDING <input checked="" type="checkbox"/> CONSTRUCTION USE*		SQ FT OF PAVEMENT* EXCAVATIONS : <u>N/A</u>	
(EXPLAIN): <u>Excavation</u>		*PAVEMENT INCLUDES: IN OR UNDER CONCRETE, OR ASPHALT INCLUDING CURBS	
EXCAVATION, LONG TERM USE FOR STORAGE OF MATERIAL/EQUIPMENT/WALKAROUND		SQ FT OF NON-PAVEMENT EXCAVATIONS: <u>287.18 Sq Ft</u>	
C. RIGHT OF WAY TO BE USED/CLOSED:		*DIRT, GRASS, GRAVEL, LANDSCAPE AREA OR OTHER UNPAVED SURFACE	
STREET NAME 1: <u>N Crescent Rd</u>		LINEAL FT OF BORE*: <u>17,918 Lineal Ft</u>	
1ST INTERSECTING STREET NAME: _____		*BORE PITS SHALL BE CALCULATED AS SQ FT EXCAVATIONS	
2ND INTERSECTING STREET NAME: _____		# OF POLE INSTALLATIONS/REMOVAL: <u>N/A</u>	
<input type="checkbox"/> ROAD CLOSURE <input checked="" type="checkbox"/> LANE CLOSURE 1 <input checked="" type="checkbox"/> 2 <input type="checkbox"/> 3 <input type="checkbox"/>		SQ FT OF SIDEWALK RECONSTRUCTION*: <u>N/A</u>	
<input checked="" type="checkbox"/> SIDEWALK* <input type="checkbox"/> BIKE LANE <input type="checkbox"/> OTHER		*CONCRETE OR ASPHALT SIDEWALK/PATH BEING IMPROVED/REPLACED	
TRANSIT STOP? <input type="checkbox"/> Y <input type="checkbox"/> N PARKING LANE(S)** <input type="checkbox"/> Y <input type="checkbox"/> N **NON-METERED		SQ FT OF SIDEWALK NEW CONSTRUCTION*: <u>N/A</u>	
START DATE: <u>Dec. 27th</u> END DATE: _____ # OF DAYS*: <u>30</u>		*CONCRETE OR ASPHALT SIDEWALK/PATH THAT IS NEW INFRASTRUCTURE	
STREET NAME 2: _____		#RESIDENTIAL DRIVEWAY INSTALLATION: <u>N/A</u>	
1ST INTERSECTING STREET NAME: _____		 <p>TO SUBMIT A LOCATE REQUEST 24 HRS A DAY, 7 DAYS A WEEK CALL 811 OR 800-382-5544 CALL 2 WORKING DAYS BEFORE YOU DIG. IT'S THE LAW.</p>	
2ND INTERSECTING STREET NAME: _____			
<input type="checkbox"/> ROAD CLOSURE <input type="checkbox"/> LANE CLOSURE 1 <input type="checkbox"/> 2 <input type="checkbox"/> 3 <input type="checkbox"/>		H. INDEMNIFICATION AGREEMENT:	
<input type="checkbox"/> SIDEWALK* <input type="checkbox"/> BIKE LANE <input type="checkbox"/> OTHER		The petitioner/applicant hereby agrees to hold harmless, defend and to indemnify the City of Bloomington from or against all claims, action, damages and expenses, including but not limited to reasonable attorney's fees or any alleged injury and/or death to any person or damage to any property arising, or alleged to have arisen out of any act of commission or omission on the part of the petitioner/applicant, his/her heirs, successors, or assigns regardless of whether such acts are the direct or indirect result of the public right-of-way use pursuant to this permit grant.	
TRANSIT STOP? <input type="checkbox"/> Y <input type="checkbox"/> N PARKING LANE(S)** <input type="checkbox"/> Y <input type="checkbox"/> N **NON-METERED		I AFFIRM, UNDER THE PENALTIES FOR PERJURY, THAT THE FOREGOING REPRESENTATIONS ARE TRUE.	
START DATE: _____ END DATE: _____ # OF DAYS*: _____		PRINT NAME: <u>Bret Simons</u>	
*SIDEWALK CLOSURES FOR A PERIOD OR PERIODS TOTALING 24HRS OR MORE SHALL INSTALL A WALKAROUND UNLESS OTHERWISE APPROVED DURING REVIEW		SIGNATURE: <u>Bret Simons</u>	
STANDARD CLOSURE HOURS MON-FRI*: 9:00 AM - 3:00 PM & 6:00 PM - 9:00 PM		DATE: <u>12/11/2023</u>	
STANDARD CLOSURE HOURS <input checked="" type="checkbox"/> *NON-STANDARD CLOSURE HOURS <input type="checkbox"/>			
REQUESTED CLOSURE HOURS: _____ AM - _____ PM			
*non-standard hours may not be allowed near schools, on arterials, or other circumstances and are subject to approval during the permitting process			
BMC 14.09.040 allows work from 6 AM to 10 PM without violating the noise ordinance (7AM to 9PM for pneumatic hammers)			

For Administration Use Only (applicable to CLOSURE approval)

Approved By: _____ BPW City Engineer Director Date: _____

Staff Representative: _____ Phone#: _____ Date: _____

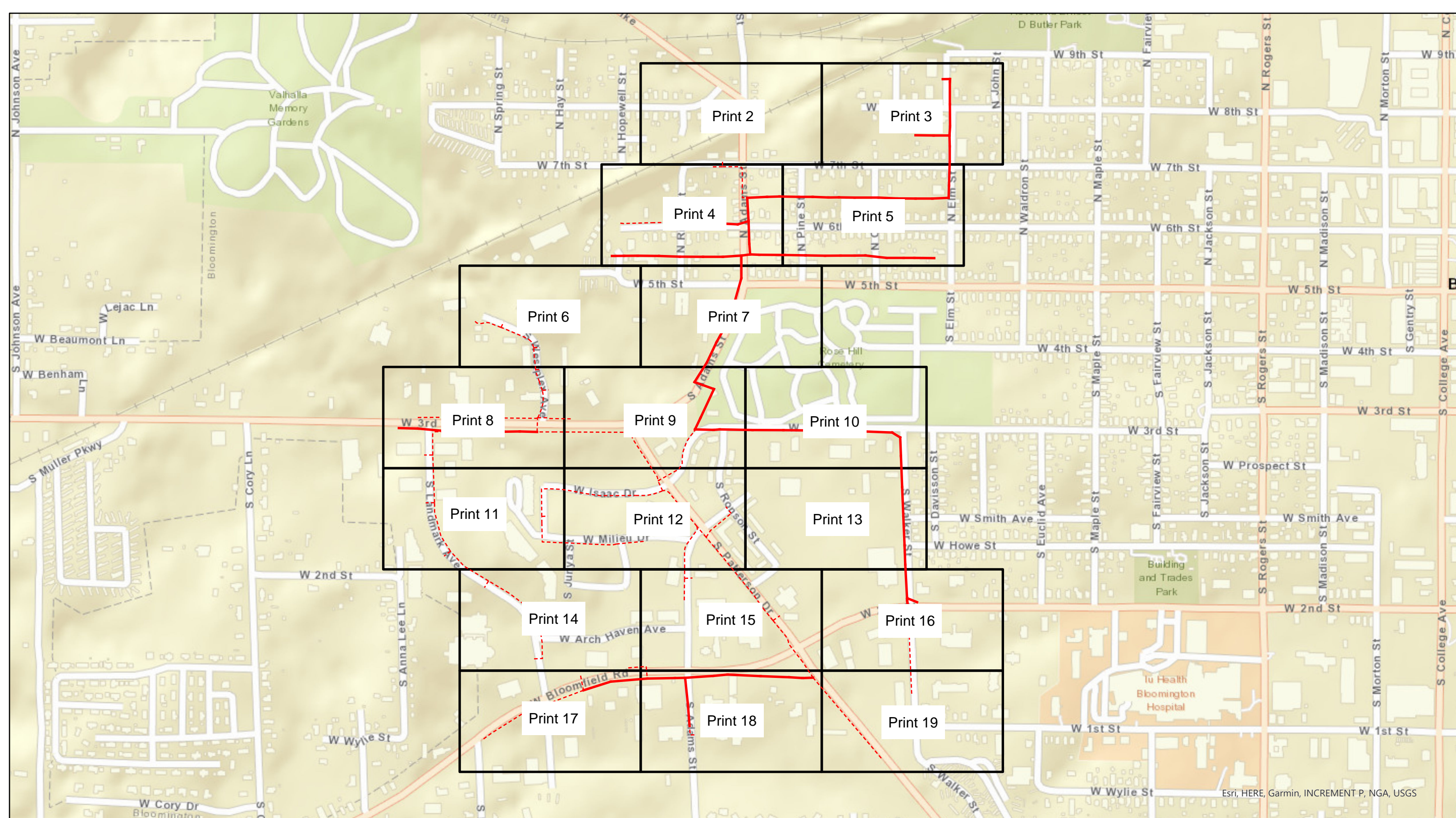

Esri, HERE, Garmin, INCREMENT P, NGA, USGS



Legend BLS01b-F09_N Pine St

- Overhead Strand
- - - Conduit
- Grids



City of Bloomington, IN Permit:
Design View

INI	BY	DATE	DESCRIPTION

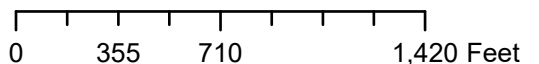

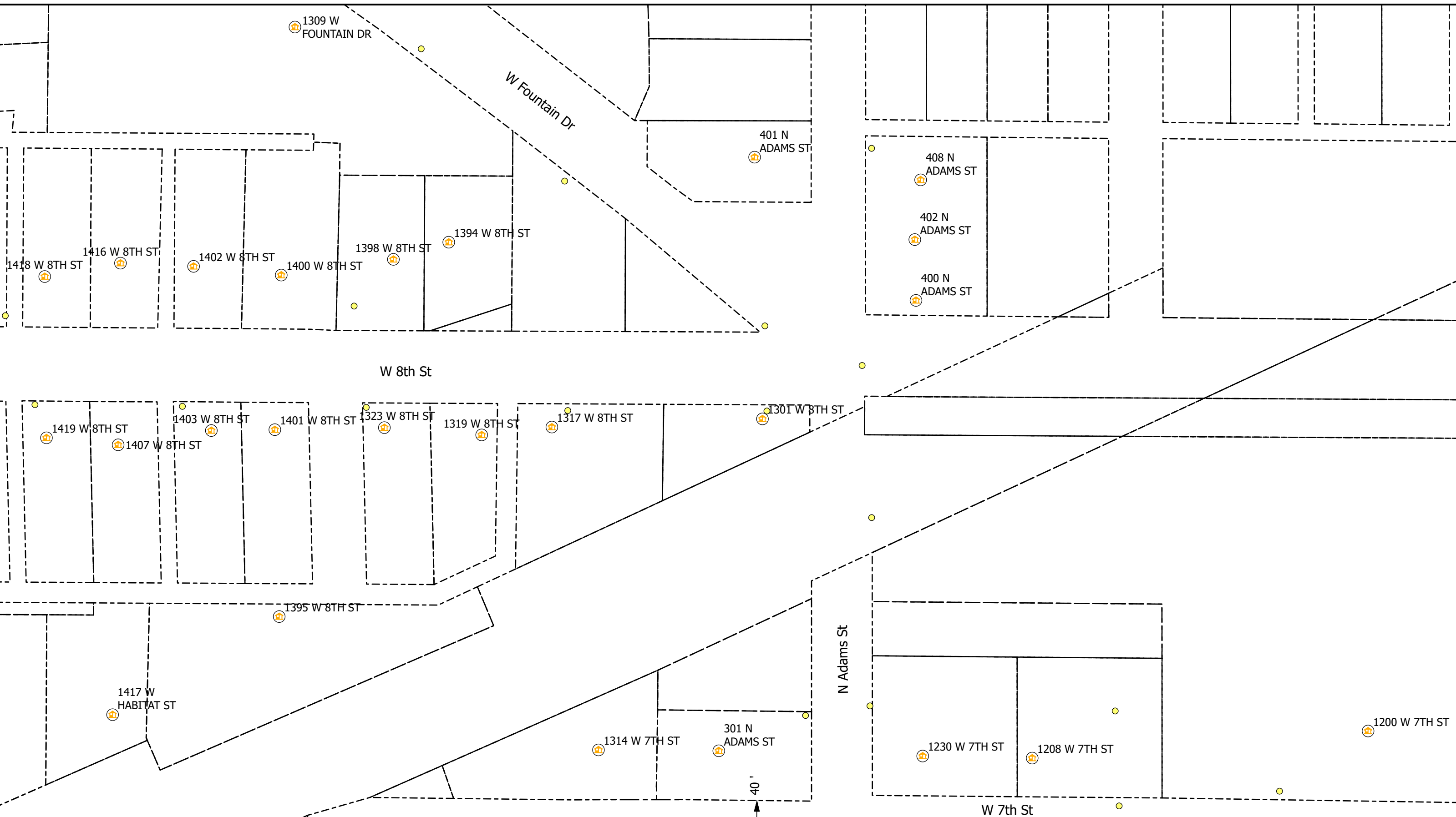

- Legend**
- Poles
 - Risers
 - Sidewalk
 - Vaults
 - Address
 - Bloomington_Parcels
 - Overhead Strand
 - Anchor
 - Conduit
 - Grids

All Flowerpots 12" DIA



City of Bloomington, IN Permit:
Design View

INI	BY	DATE	DESCRIPTION



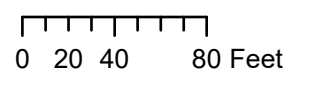
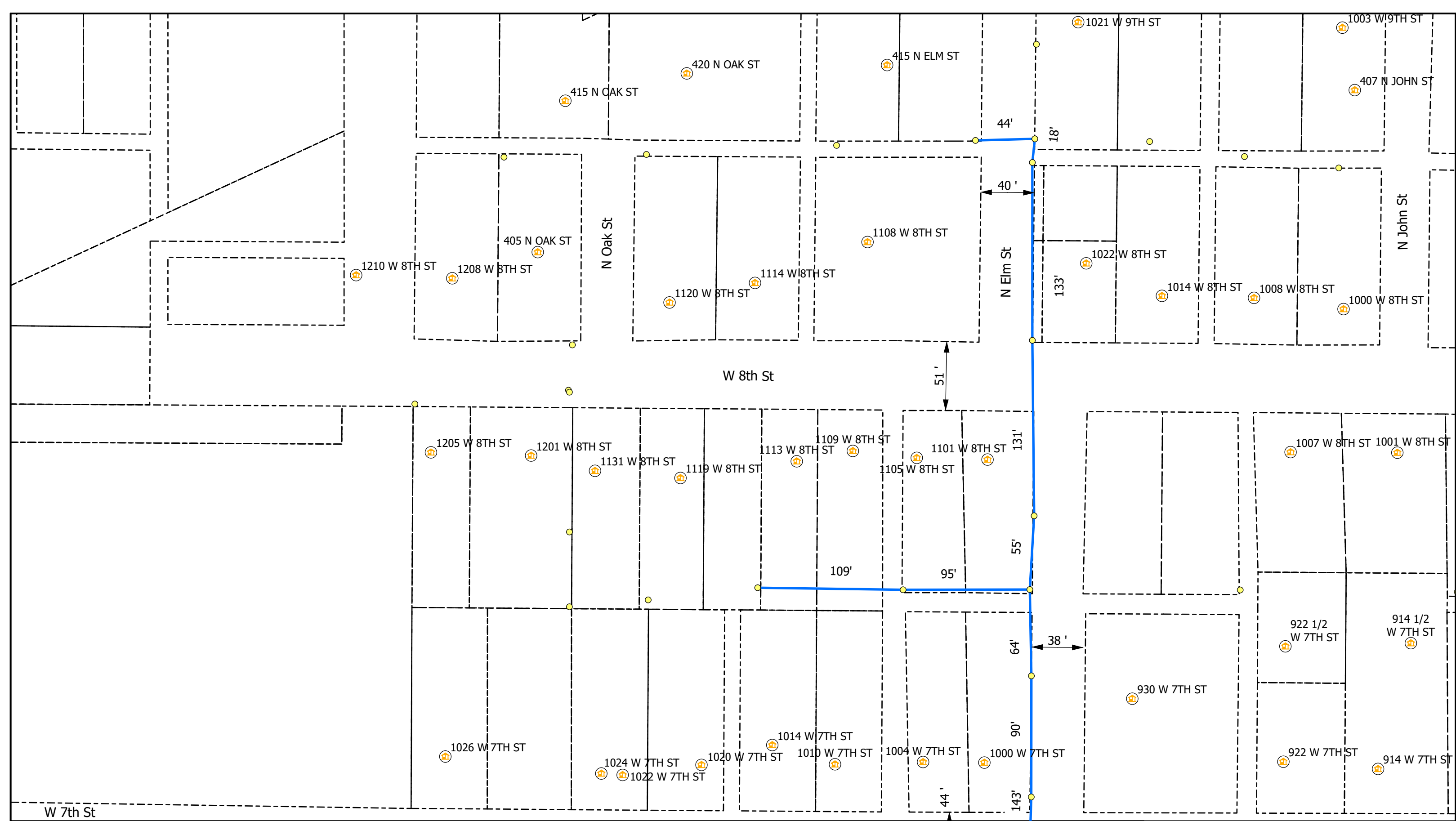

Legend

- Poles
- Ⓡ Risers
- Ⓜ Vaults
- Overhead Strand
- - - Conduit
- 🏠 Address
- Y Anchor
- ↖ Sidewalk
- Bloomington_Parcels
- Grids

All Flowerpots 12" DIA



City of Bloomington, IN Permit:
Design View

INI	BY	DATE	DESCRIPTION



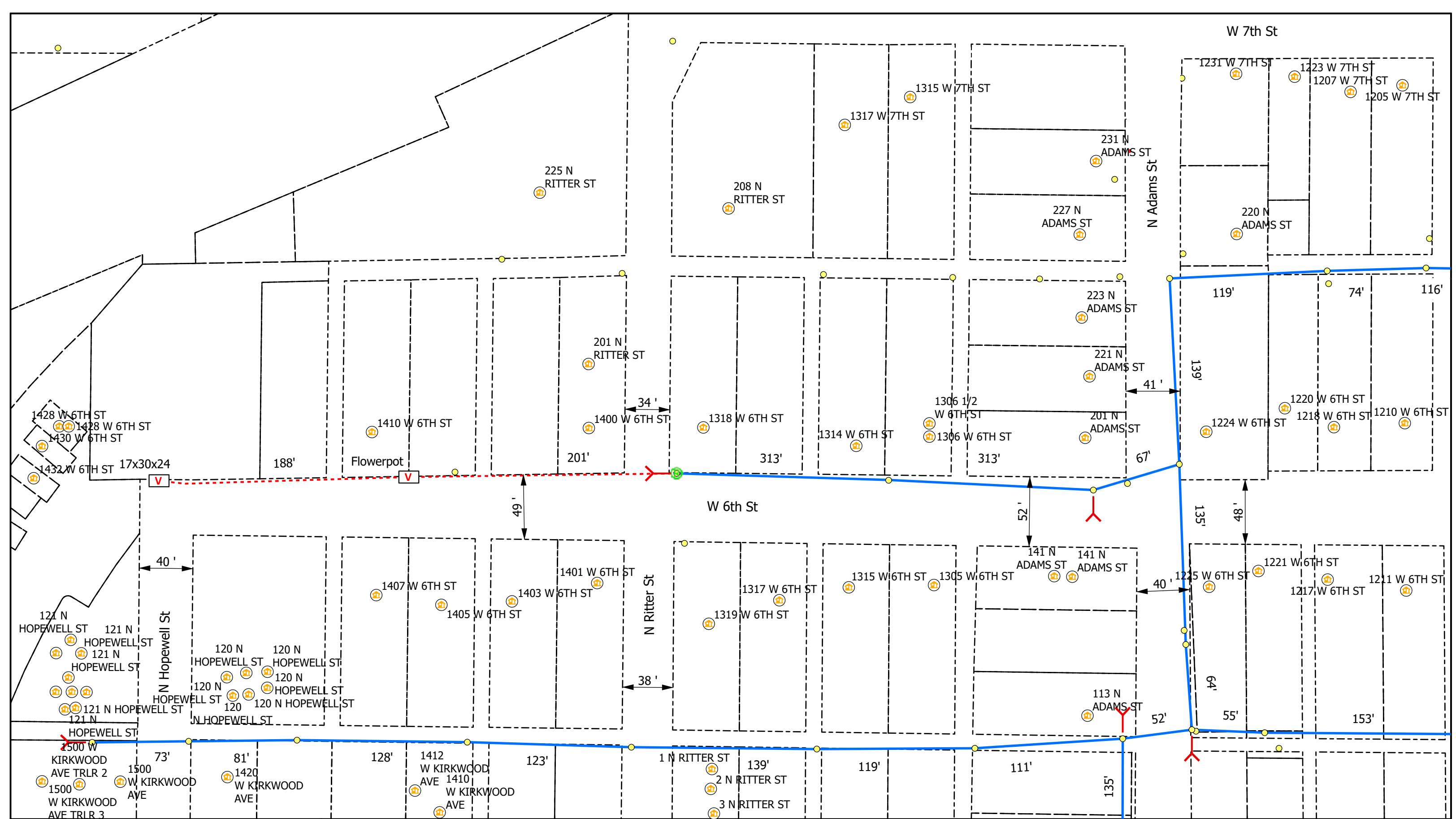

Legend

- Poles
- Ⓜ Vaults
- Overhead Strand
- - - Conduit
- Ⓢ Risers
- 🏠 Address
- ⌵ Anchor
- ↔ Sidewalk
- ⌚ Bloomington_Parcels
- ▭ Grids

All Flowerpots 12" DIA

City of Bloomington, IN Permit:
Design View

INI	BY	DATE	DESCRIPTION

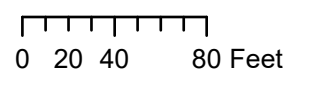
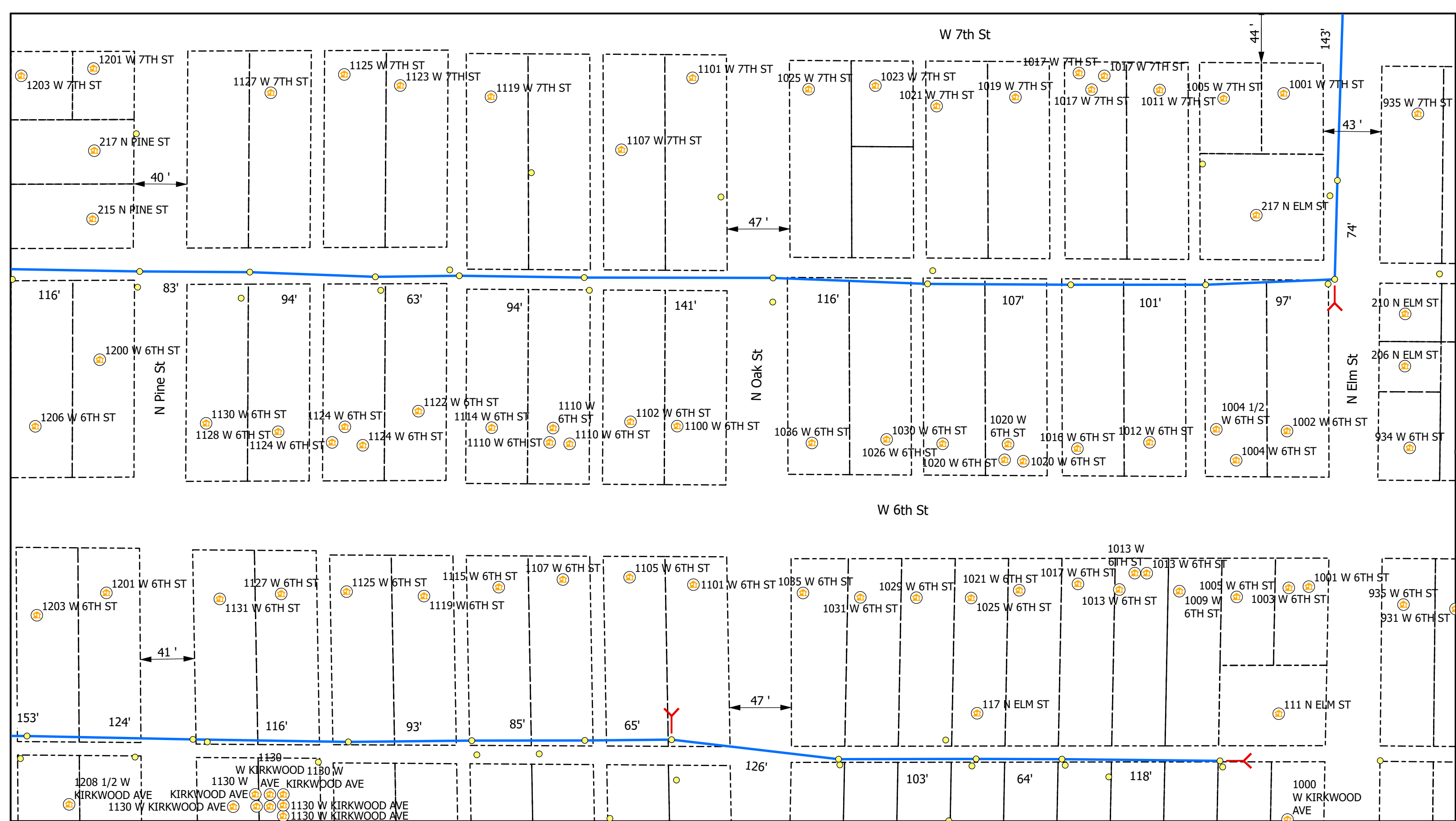

Legend

- Poles
- Ⓜ Risers
- V Vaults
- 🏠 Address
- Overhead Strand
- Conduit
- ↙ Sidewalk
- Bloomington_Parcels
- Grids
- Y Anchor

All Flowerpots 12" DIA



City of Bloomington, IN Permit:
Design View

INI	BY	DATE	DESCRIPTION



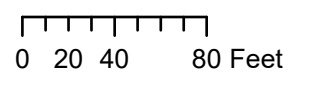
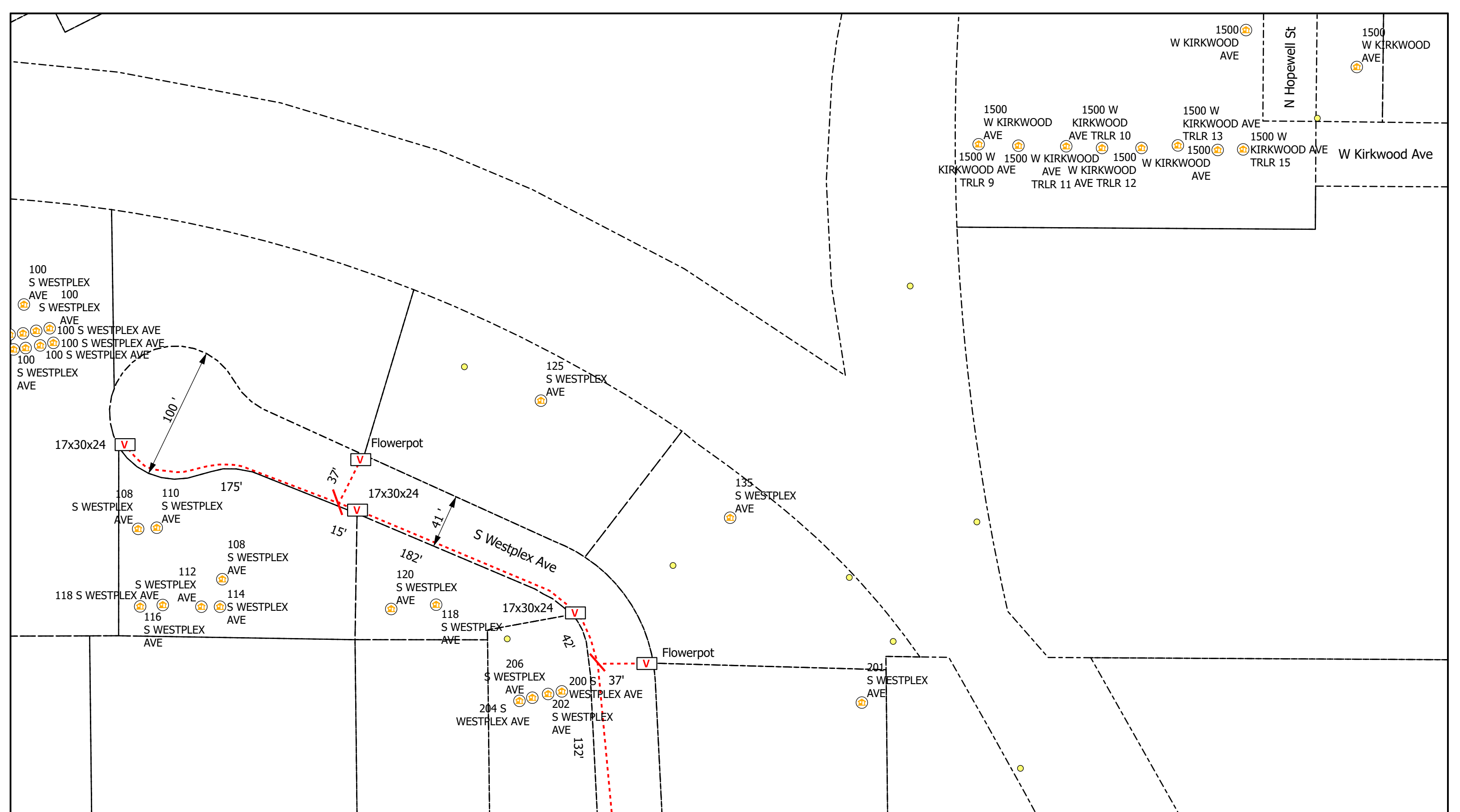

Legend

- Poles
- Ⓡ Risers
- Ⓜ Sidewalk
- V Vaults
- 🏠 Address
- Bloomington_Parcels
- Overhead Strand
- Conduit
- Y Anchor
- Grids

All Flowerpots 12" DIA



City of Bloomington, IN Permit:
Design View

INI	BY	DATE	DESCRIPTION



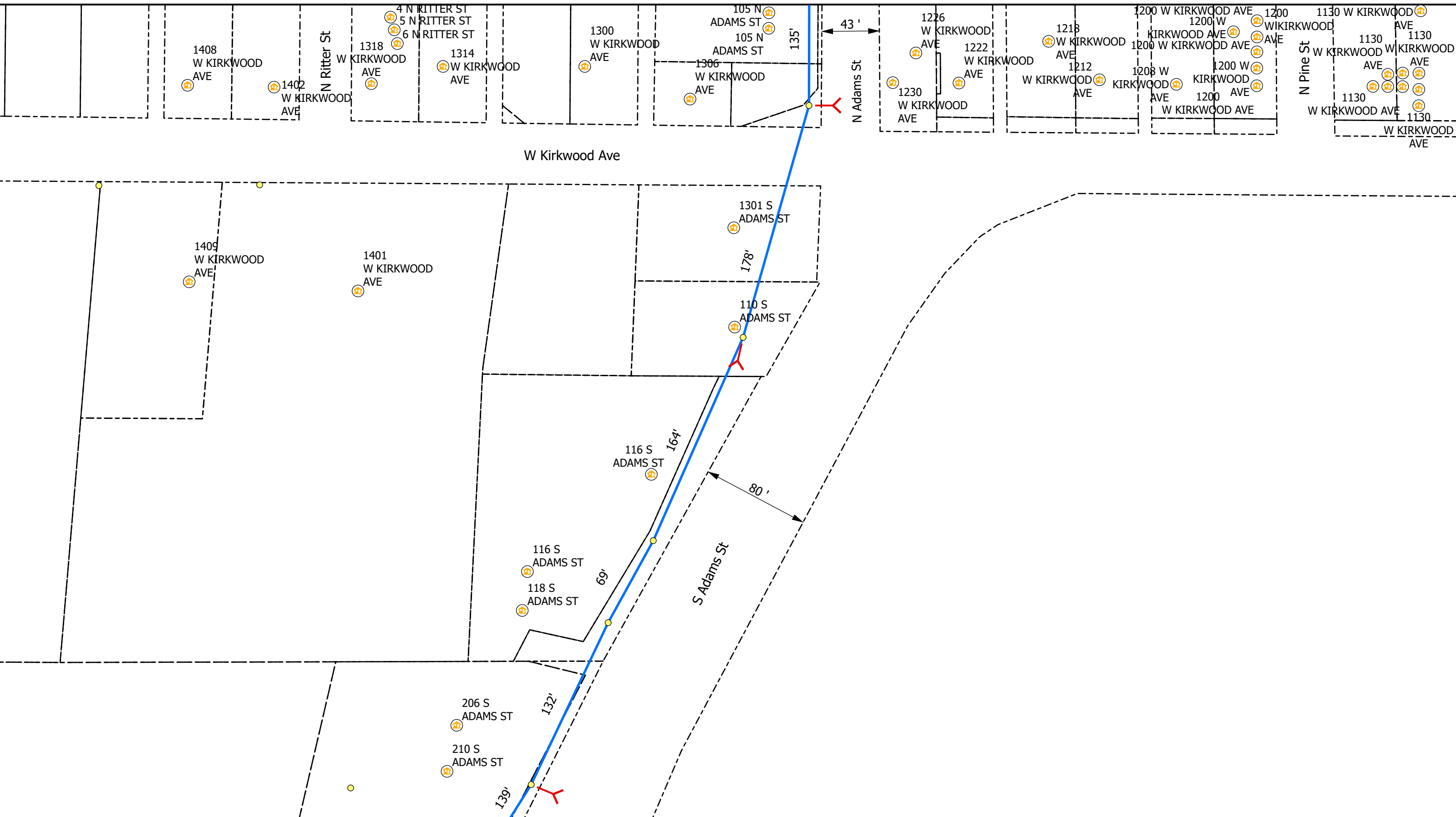

Legend

- Poles
- Ⓡ Risers
- ⏏ Sidewalk
- V Vaults
- 🏠 Address
- Bloomington_Parcels
- Overhead Strand
- Y Anchor
- Grids
- - - Conduit

All Flowerpots 12" DIA



City of Bloomington, IN Permit:
Design View

INI	BY	DATE	DESCRIPTION



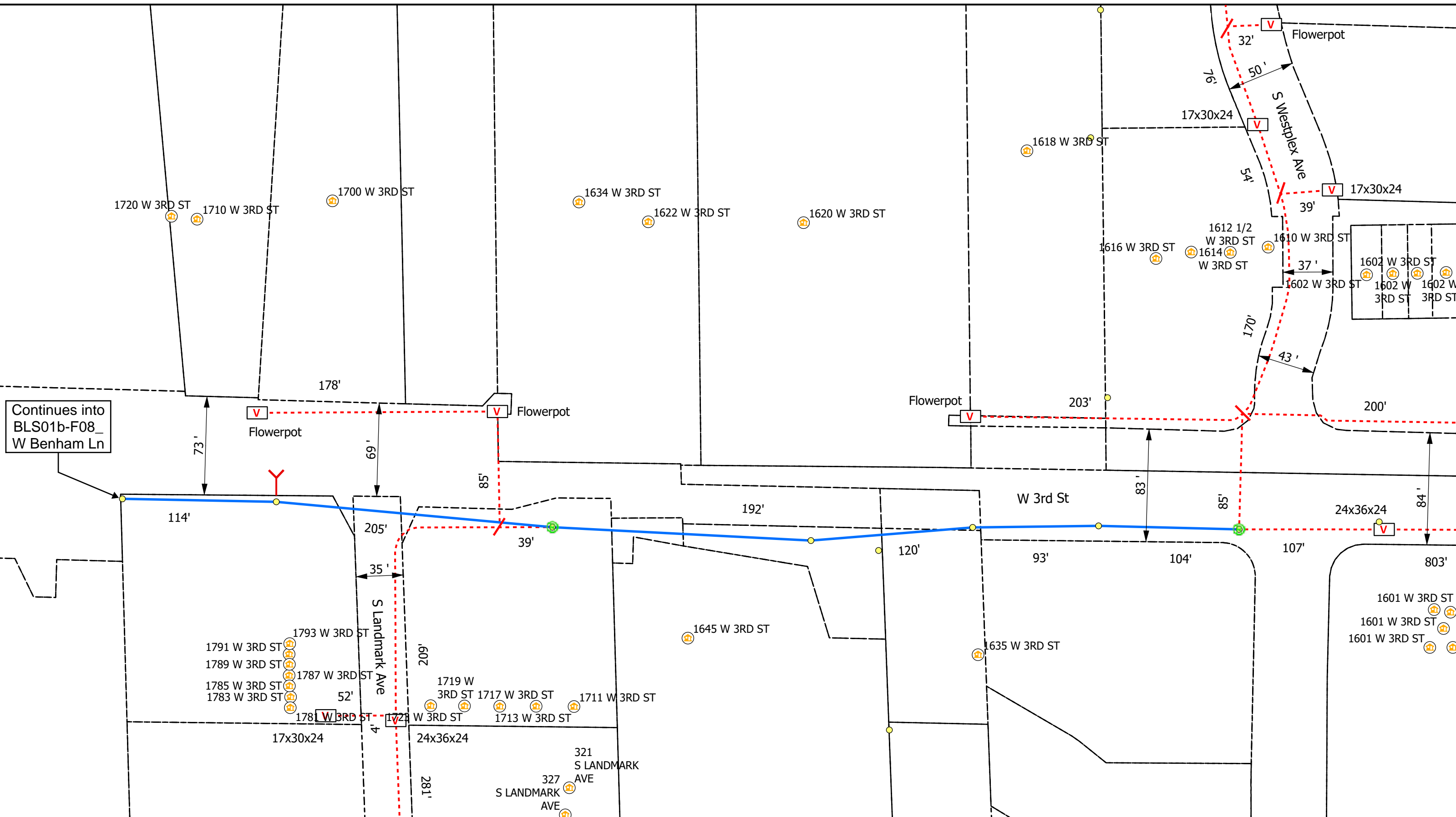

AEG

0 20 40 80 Feet

Legend

- Poles
- Vaults
- Overhead Strand
- Conduit
- Risers
- Address
- Anchor
- Sidewalk
- Bloomington_Parcels
- Grids

All Flowerpots 12" DIA

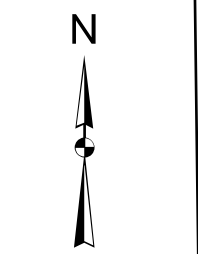

City of Bloomington, IN Permit:
Design View

INI	BY	DATE	DESCRIPTION

Print 8 of 19

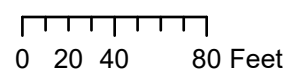
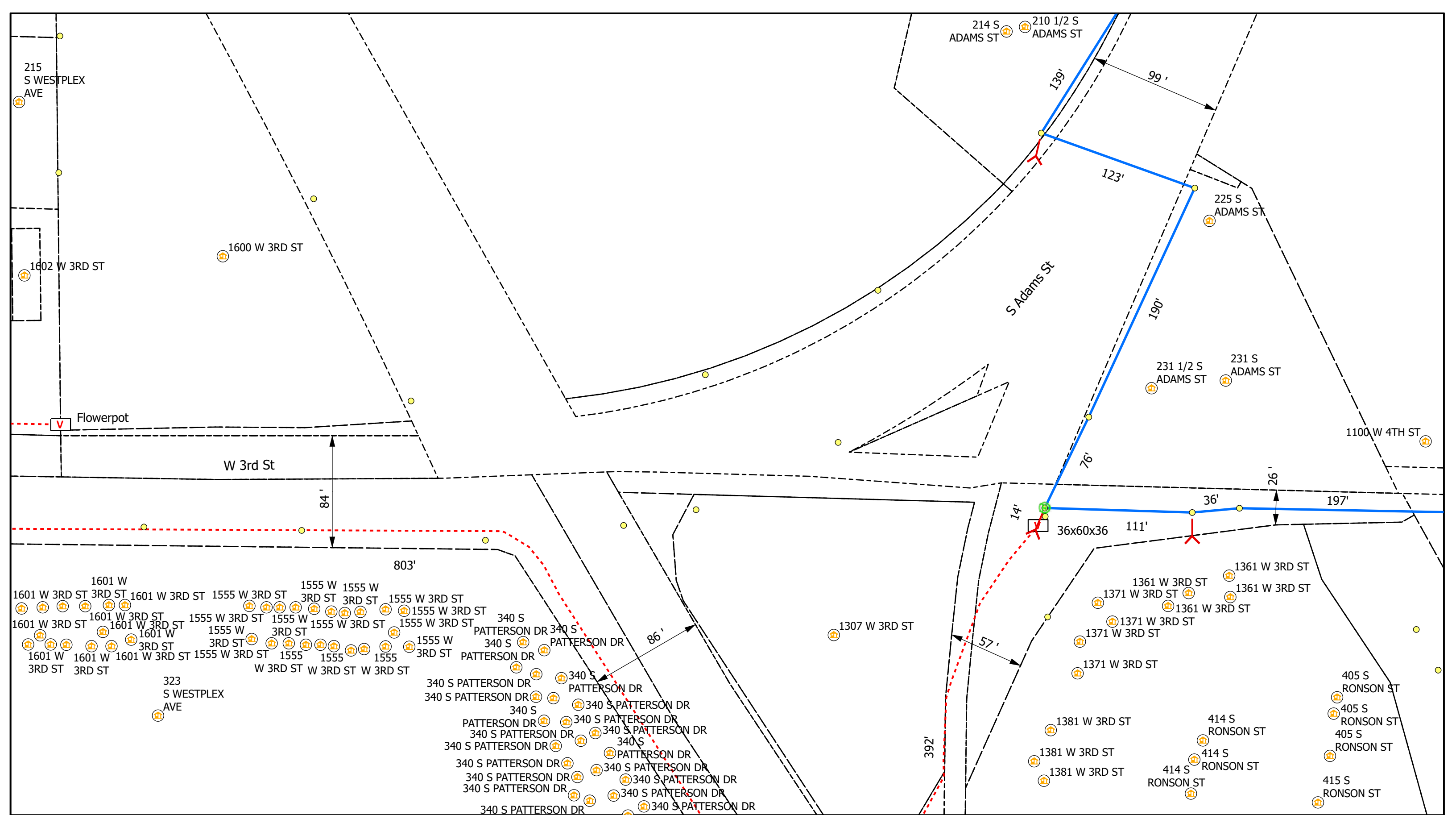

Legend

- Poles
- ⊕ Risers
- ⌞ Sidewalk
- V Vaults
- Ⓜ Address
- Bloomington_Parcels
- Overhead Strand
- - - Conduit
- Y Anchor
- Grids

All Flowerpots 12" DIA



City of Bloomington, IN Permit:
Design View

INI	BY	DATE	DESCRIPTION



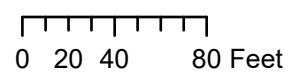
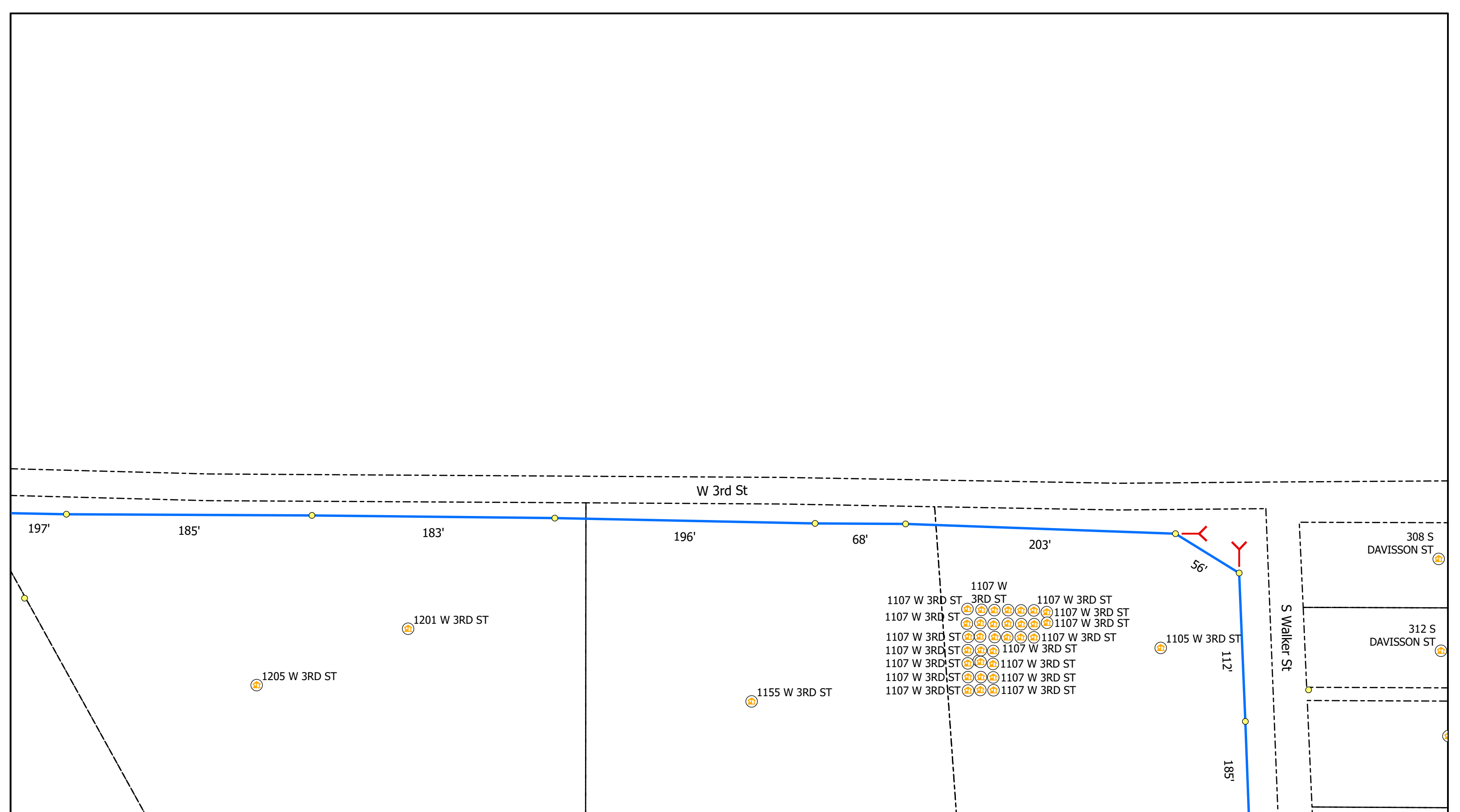

Legend

- Poles
- Ⓡ Risers
- Ⓜ Sidewalk
- V Vaults
- 🏠 Address
- Bloomington_Parcels
- Overhead Strand
- Y Anchor
- - - Conduit
- Grids

All Flowerpots 12" DIA



City of Bloomington, IN Permit:
Design View

INI	BY	DATE	DESCRIPTION



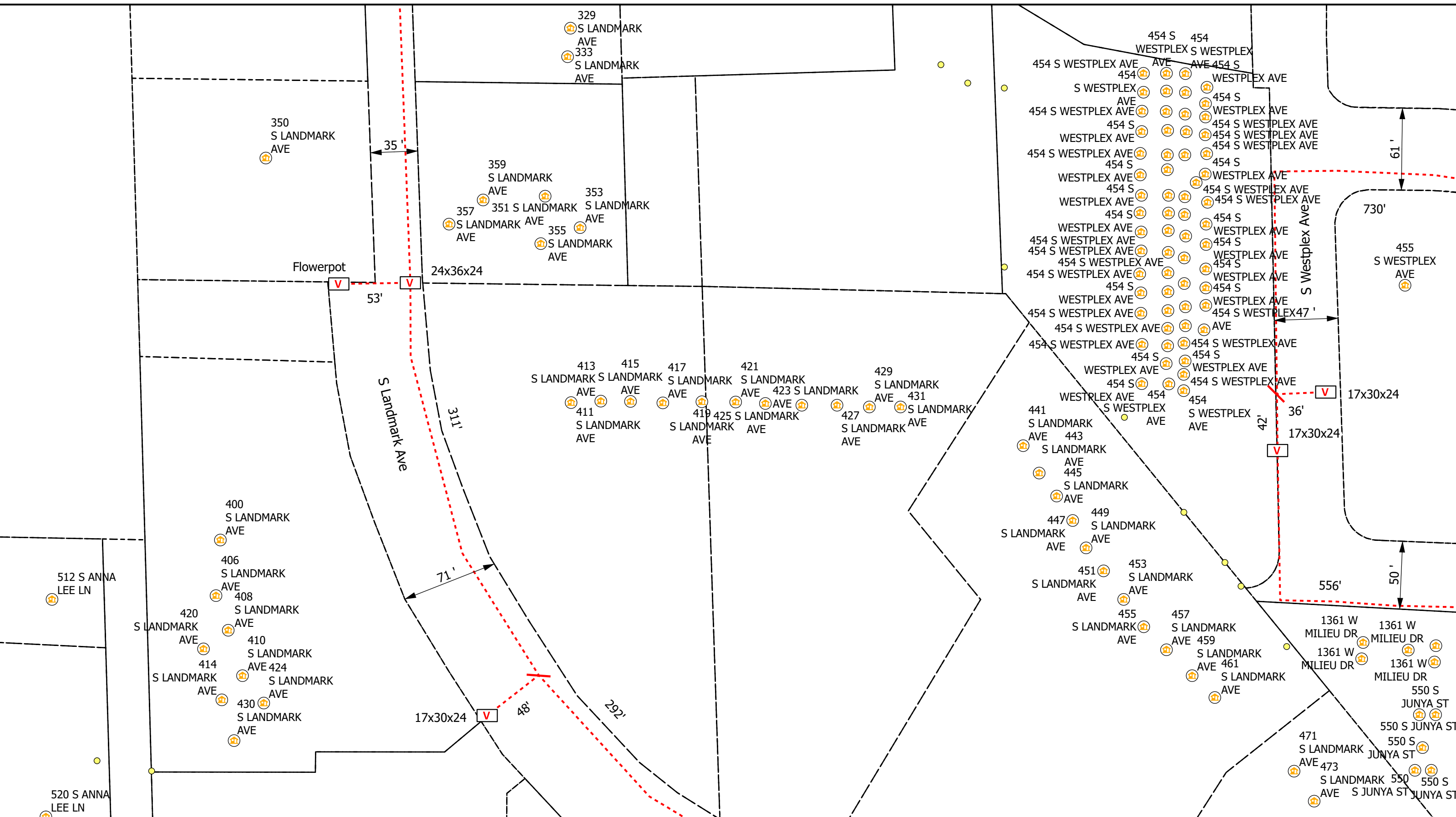

Legend

- Poles
- Ⓡ Risers
- Ⓜ Address
- Ⓜ Anchor
- V Vaults
- Overhead Strand
- Conduit
- ↖ Sidewalk
- Bloomington_Parcels
- Grids

All Flowerpots 12" DIA



City of Bloomington, IN Permit:
Design View

INI	BY	DATE	DESCRIPTION



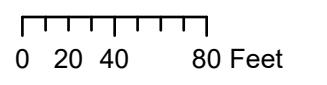
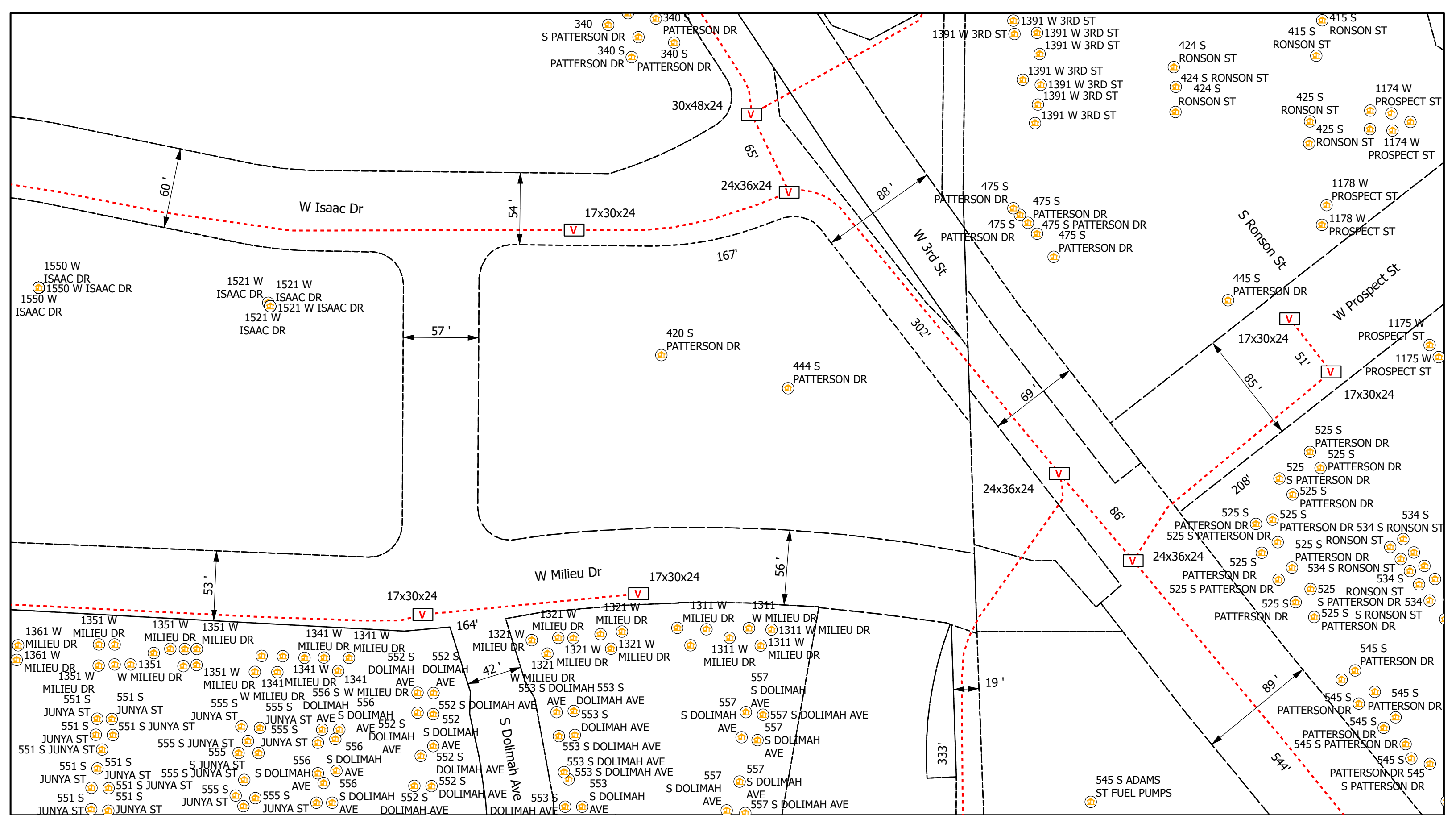

Legend

- Poles
- ⊕ Risers
- V Vaults
- Overhead Strand
- Conduit
- Ⓜ Address
- ↖ Sidewalk
- Bloomington_Parcels
- Grids
- Y Anchor

All Flowerpots 12" DIA



City of Bloomington, IN Permit:
Design View

INI	BY	DATE	DESCRIPTION



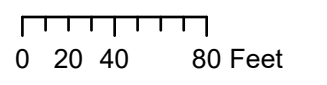

Legend

- Poles
- Ⓡ Risers
- ⏏ Sidewalk
- V Vaults
- 🏠 Address
- Bloomington_Parcels
- Overhead Strand
- Y Anchor
- Conduit
- Grids

All Flowerpots 12" DIA



City of Bloomington, IN Permit:
Design View

INI	BY	DATE	DESCRIPTION



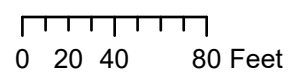
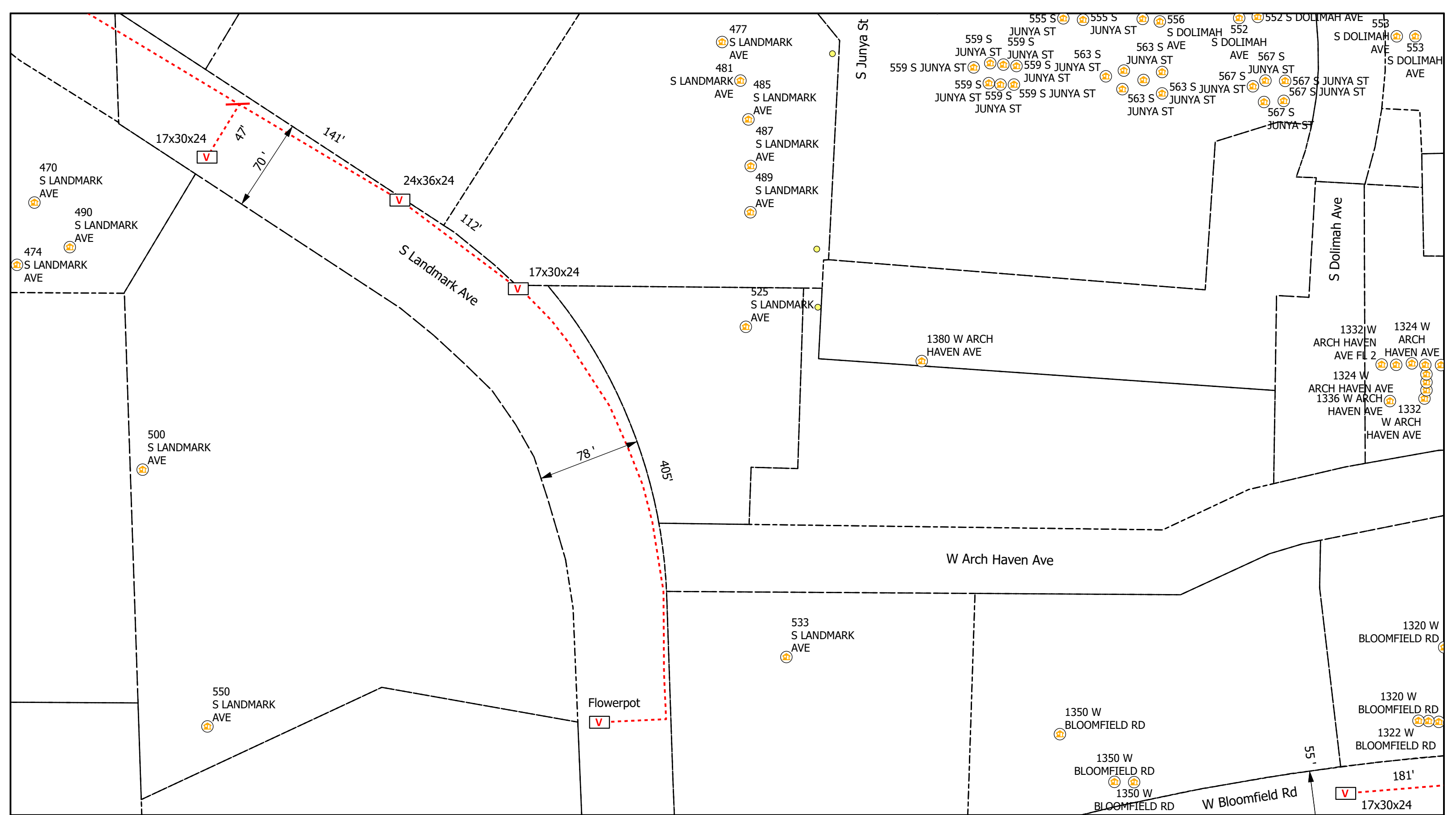

Legend

- Poles
- V Vaults
- Overhead Strand
- Conduit
- Ⓡ Risers
- Ⓜ Address
- Y Anchor
- ↖ Sidewalk
- Bloomington_Parcels
- Grids

All Flowerpots 12" DIA



City of Bloomington, IN Permit:
Design View

INI	BY	DATE	DESCRIPTION



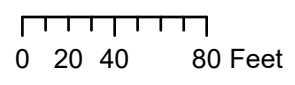
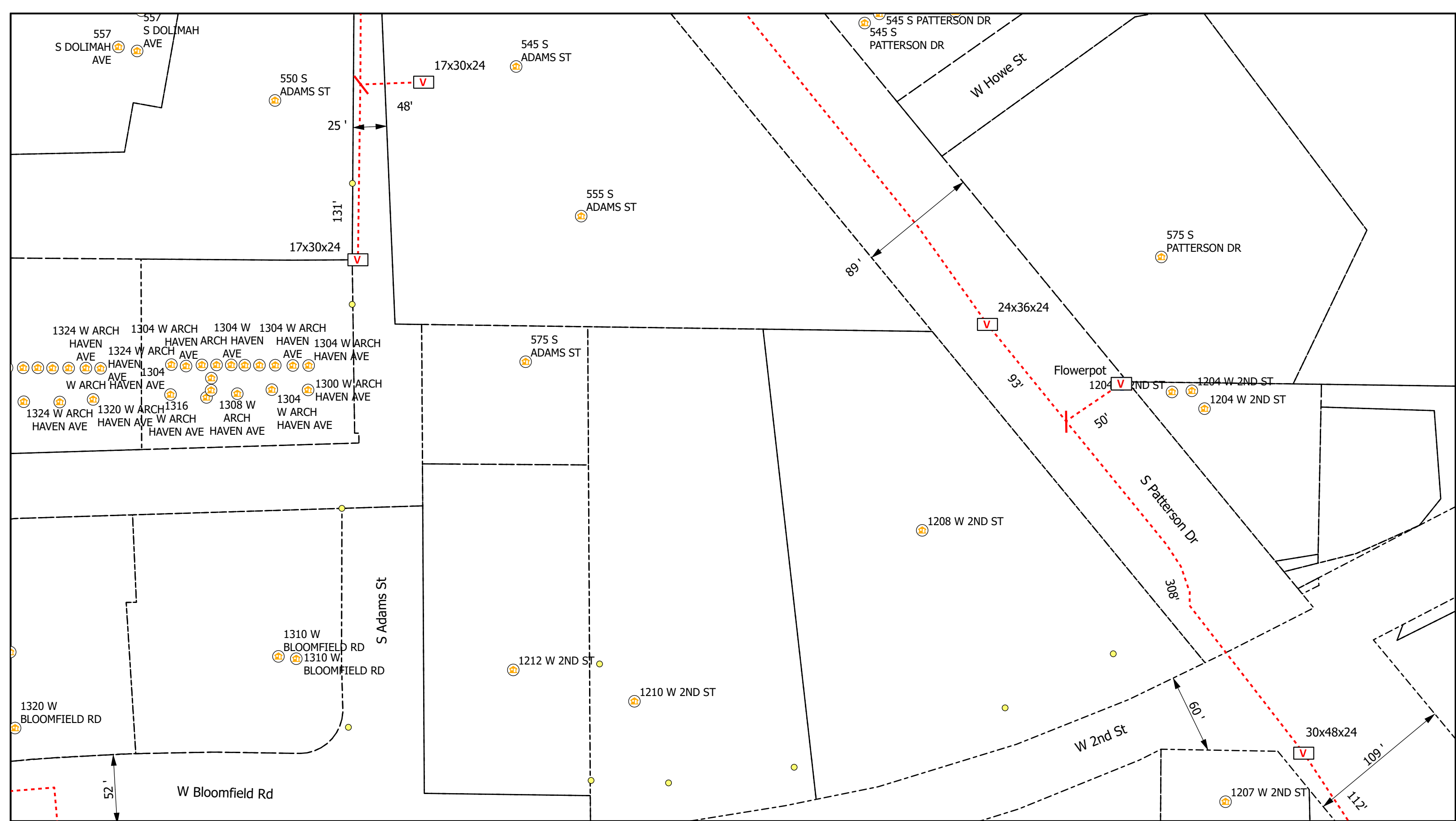

Legend

- Poles
- Ⓡ Risers
- Ⓜ Sidewalk
- V Vaults
- Overhead Strand
- - - Conduit
- 🏠 Address
- Y Anchor
- Bloomington_Parcels
- Grids

All Flowerpots 12" DIA



City of Bloomington, IN Permit:
Design View

INI	BY	DATE	DESCRIPTION



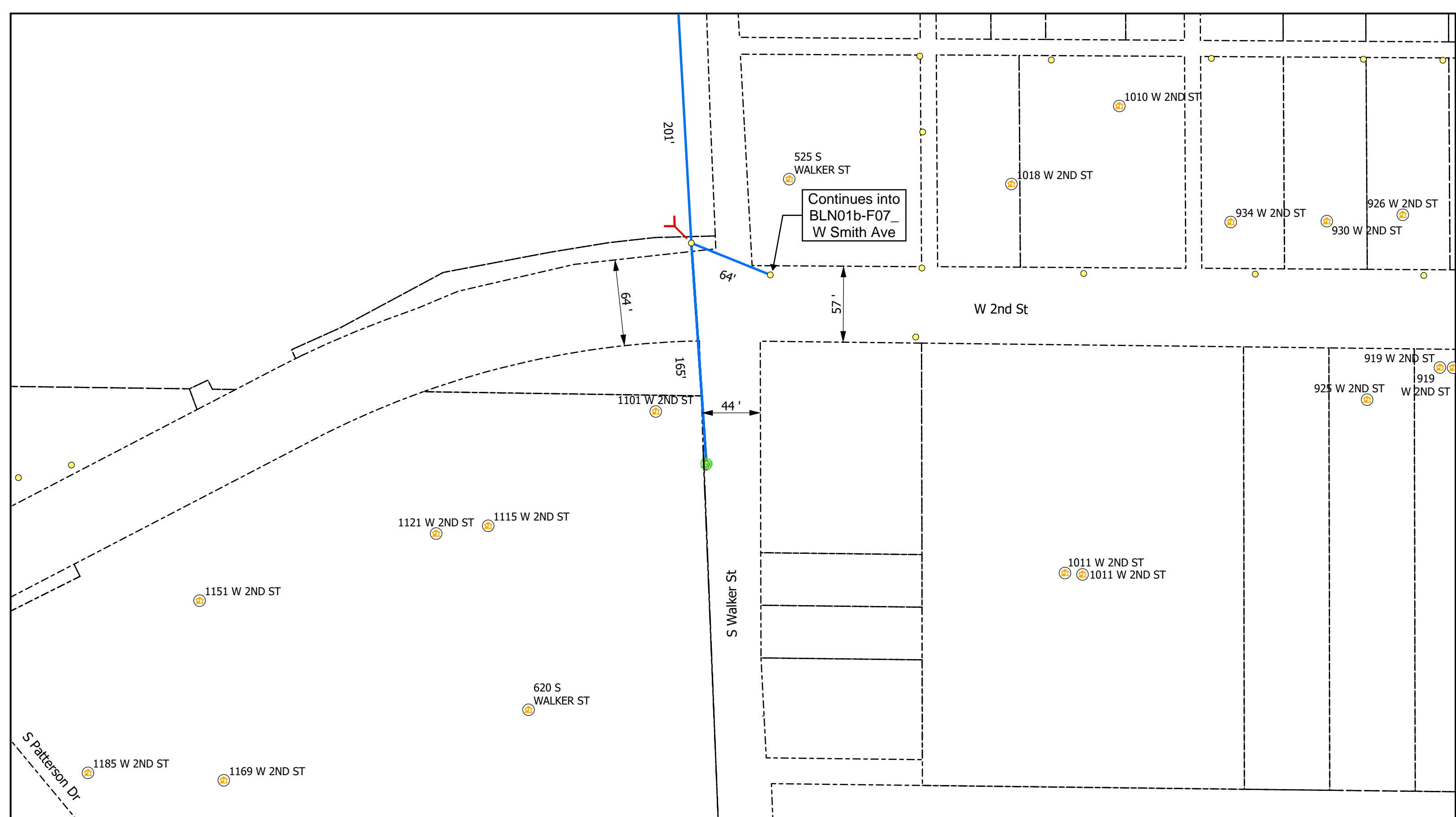

0 20 40 80 Feet

Legend

- Poles
- Ⓜ Risers
- Ⓜ Sidewalk
- V Vaults
- 🏠 Address
- Bloomington_Parcels
- Overhead Strand
- Y Anchor
- Conduit
- Grids

All Flowerpots 12" DIA



City of Bloomington, IN Permit:
Design View

INI	BY	DATE	DESCRIPTION



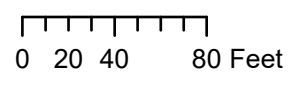
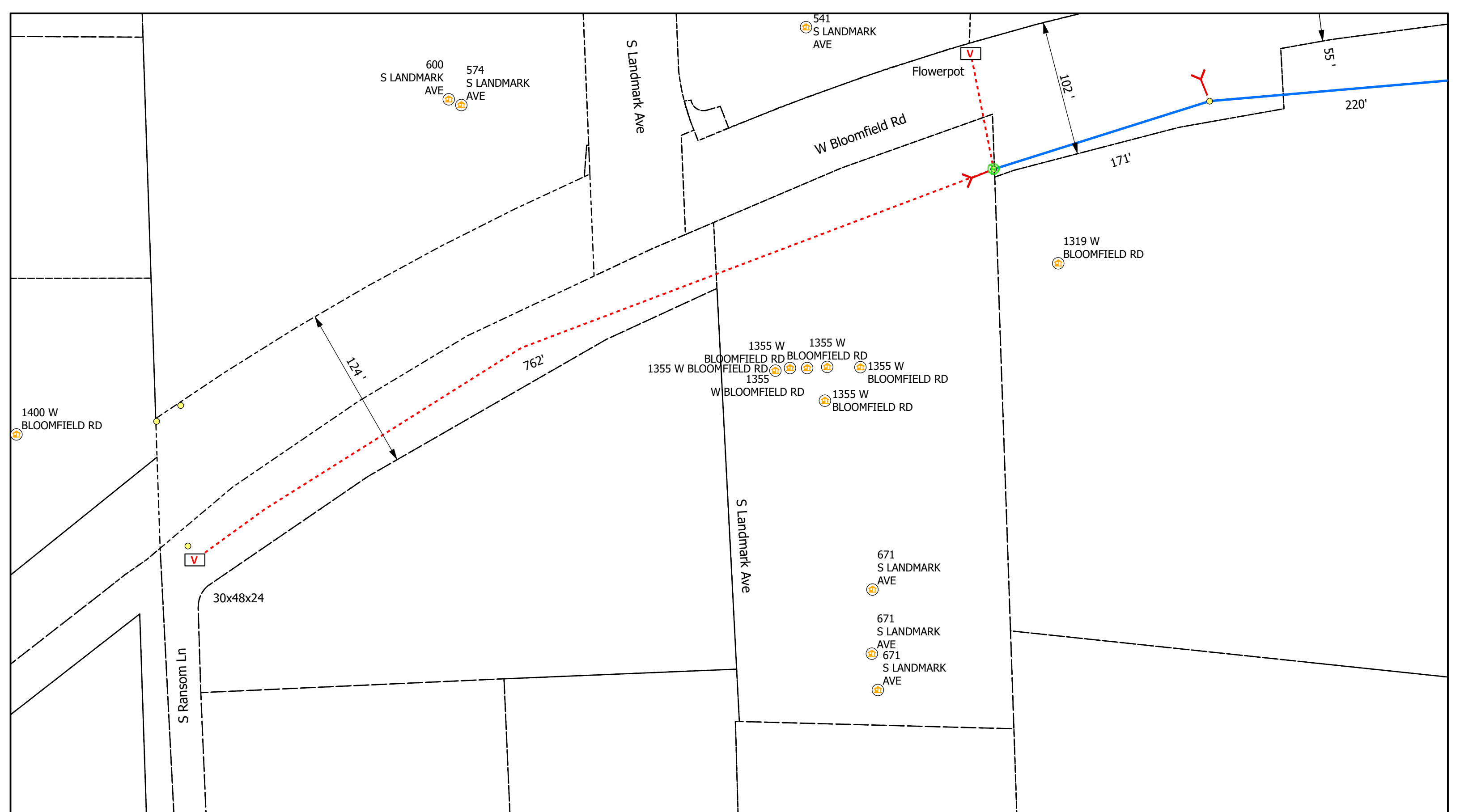

Legend

- Poles
- V Vaults
- Overhead Strand
- Conduit
- R Risers
- A Address
- Y Anchor
- ⤴ Sidewalk
- Bloomington_Parcels
- Grids

All Flowerpots 12" DIA



City of Bloomington, IN Permit:
Design View

INI	BY	DATE	DESCRIPTION



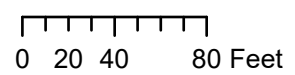
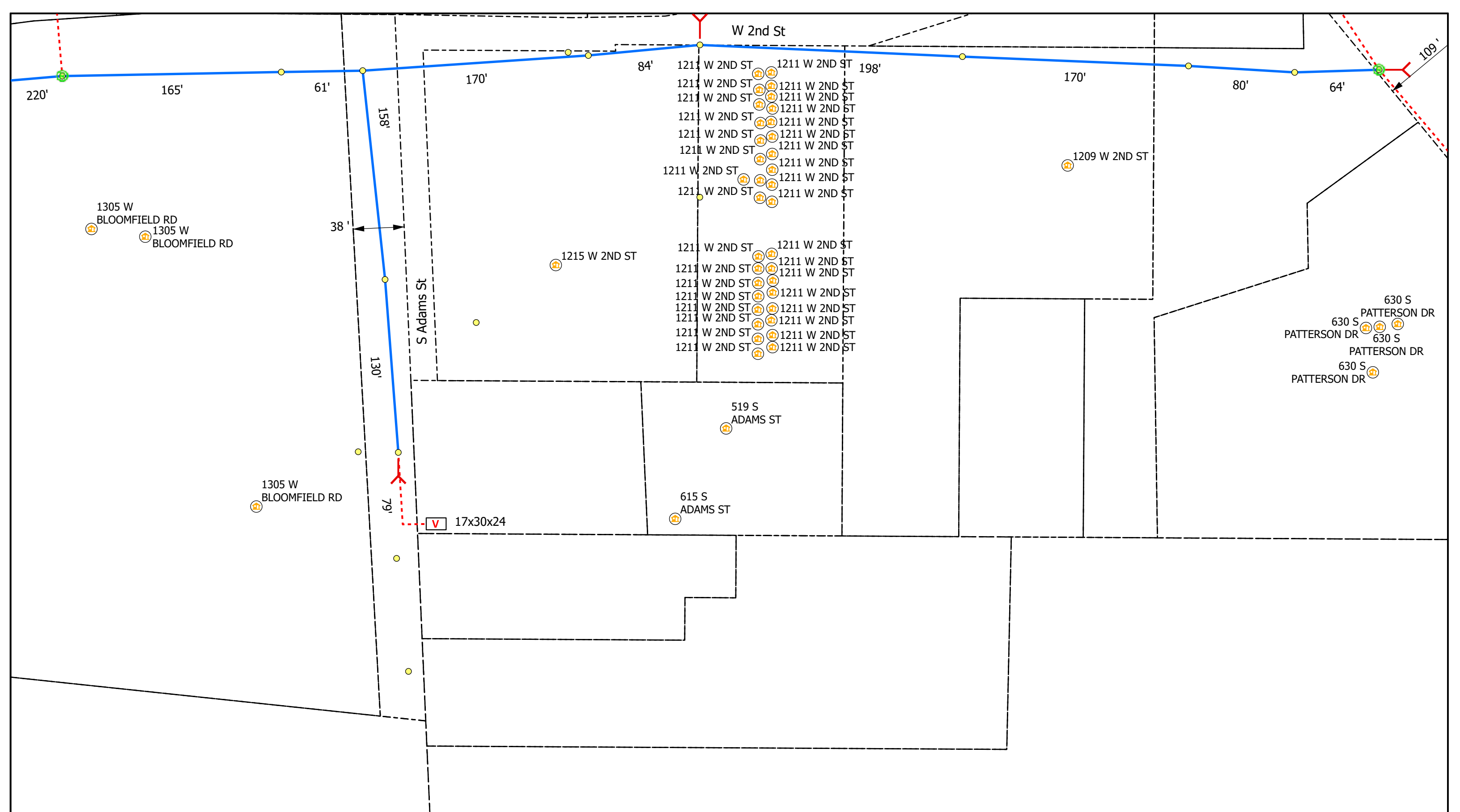

Legend

- Poles
- Ⓡ Risers
- Ⓜ Sidewalk
- V Vaults
- Ⓜ Address
- Bloomington_Parcels
- Overhead Strand
- Conduit
- Y Anchor
- Grids

All Flowerpots 12" DIA



City of Bloomington, IN Permit:
Design View

INI	BY	DATE	DESCRIPTION



Carlton® PV-Mold® Nonmetallic Pole Riser System

Carlton PV-Mold is a nonmetallic pole riser system designed to protect communications power cable installed on poles.

Features:

- Meets or exceeds requirements outlined in the National Electric Safety Code (NESC).
- Designed in accordance with NEMA TC-19 specifications.
- Ultraviolet, cold temperature and corrosive atmosphere resistant.
- Schedule 40 wall meets Schedule 80 PVC conduit impact requirements per NEMA TC-19.
- No grounding required.
- Belled end fits over each added section or conduit.
- Flame retardant.
- Requires no maintenance.
- PV-Mold acts as an insulator against electrical shock.
- Interchangeable parts and accessories to match the needs of specific requirements.



Steel U-Guard requires grounding strapping and does not have belled ends.



PV-Mold has belled ends, flanged design and does not require grounding.

Flanged Overall Length 10 Feet, Including Bell

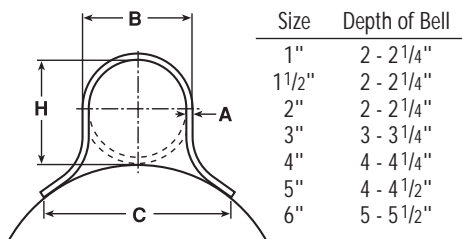

Slots are 1/2" from side to side, and allow for expansion and contraction.

Slot Dimensions: for sizes 2" through 6" are 5/16" wide, 3/4" long.

Slot Dimensions: for 1" and 1 1/2" are 3/16" wide, 3/4" long.

Slot Spacing: 18" from center, beginning 6" from end.

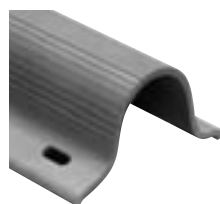

Standard Duty

Part No.	Size	Std. Ctn. Qty.	Std. Ctn. Wt. (lbs.)	Dimensions				Actual Impact @ 0°C 20 Pound Top
				A	B	C	H	
59208N	1"	294	1059	0.100"	1 5/8"	2 3/8"	1 5/8"	40 Ft.-Lbs.
59211N	2"	136	726	0.100"	2 3/8"	4 1/2"	2 3/8"	100 Ft.-Lbs.
59211X (5' length)	2"	136	363	0.100"	2 3/8"	4 1/2"	2 3/8"	100 Ft.-Lbs.
59213N	3"	66	761	0.150"	3 1/2"	6"	3 1/2"	110 Ft.-Lbs.
59213X (5' length)	3"	66	381	0.150"	3 1/2"	6"	3 1/2"	100 Ft.-Lbs.
59215N	4"	65	910	0.150"	4 1/2"	6 1/2"	4 1/2"	110 Ft.-Lbs.
59216N	5"	30	515	0.150"	5 1/2"	7 1/2"	5 1/2"	110 Ft.-Lbs.

Heavy Duty Schedule 40

59010N	1 1/2"	200	1142	0.145"	1 29/32"	3 1/2"	1 29/32"	100 Ft.-Lbs.
59011N	2"	136	1214	0.154"	2 3/8"	4 1/2"	2 3/8"	150 Ft.-Lbs.
59013N	3"	66	937	0.216"	3 1/2"	6"	3 9/32"	150 Ft.-Lbs.
59015N	4"	65	1621	0.237"	4 1/2"	6 1/2"	4 1/2"	260 Ft.-Lbs.
59015X (5' length)	4"	65	707	0.237"	4 1/2"	6 1/2"	4 1/2"	260 Ft.-Lbs.
59016N	5"	30	870	0.258"	5 1/2"	7 1/2"	5 1/2"	260 Ft.-Lbs.
59017N	6"	30	1160	0.280"	6 5/8"	8 3/4"	6 5/8"	260 Ft.-Lbs.

Extra Heavy Duty Schedule 80

59411N	2"	136	1549	0.218"	2 3/8"	4 1/2"	2 3/8"	300 Ft.-Lbs.
59413N	3"	66	1495	0.030"	3 1/2"	6"	3 1/2"	525 Ft.-Lbs.

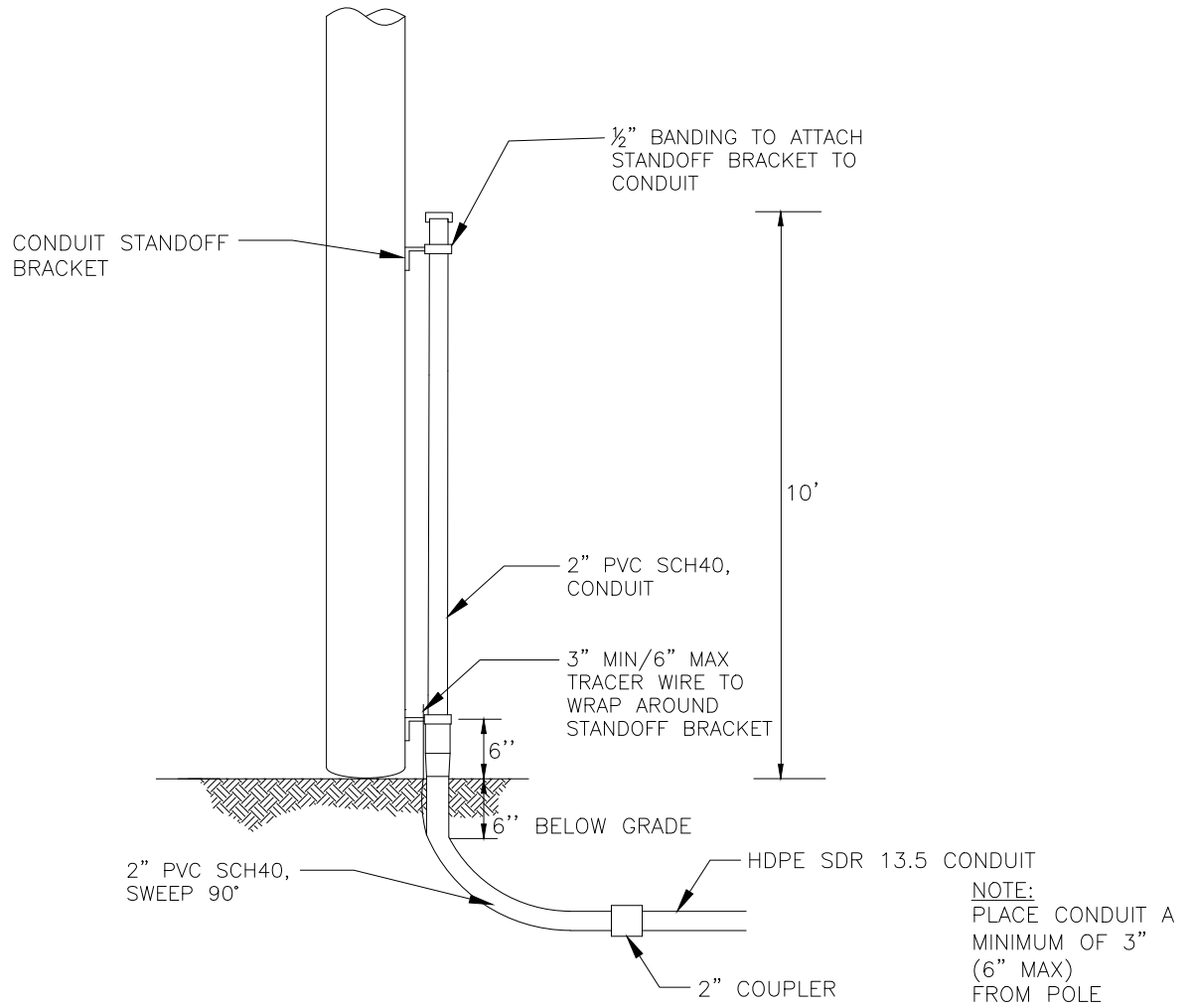

DESCRIPTION	QTY	MANUFACTURER (PREFERRED)	PART #
SCREW, LAG, 1/2" x 4-1/2"	10		
HDPE SDR 13.5 CONDUIT, VARIOUS SIZES	N/A		
2" PVC SCH40, RISER PIPE	1		
#12 TRACER WIRE	N/A		
2" PVC SCH40, SWEEP, 90 DEG	1		
CONDUIT STANDOFF BRACKET	VARIES		
CONDUIT STRAP KIT	VARIES		
2" COUPLER	1		



TYPICAL RISER
CONDUIT
WOOD POLE

(R2-W)

CONCEPTUAL SIDE VIEW

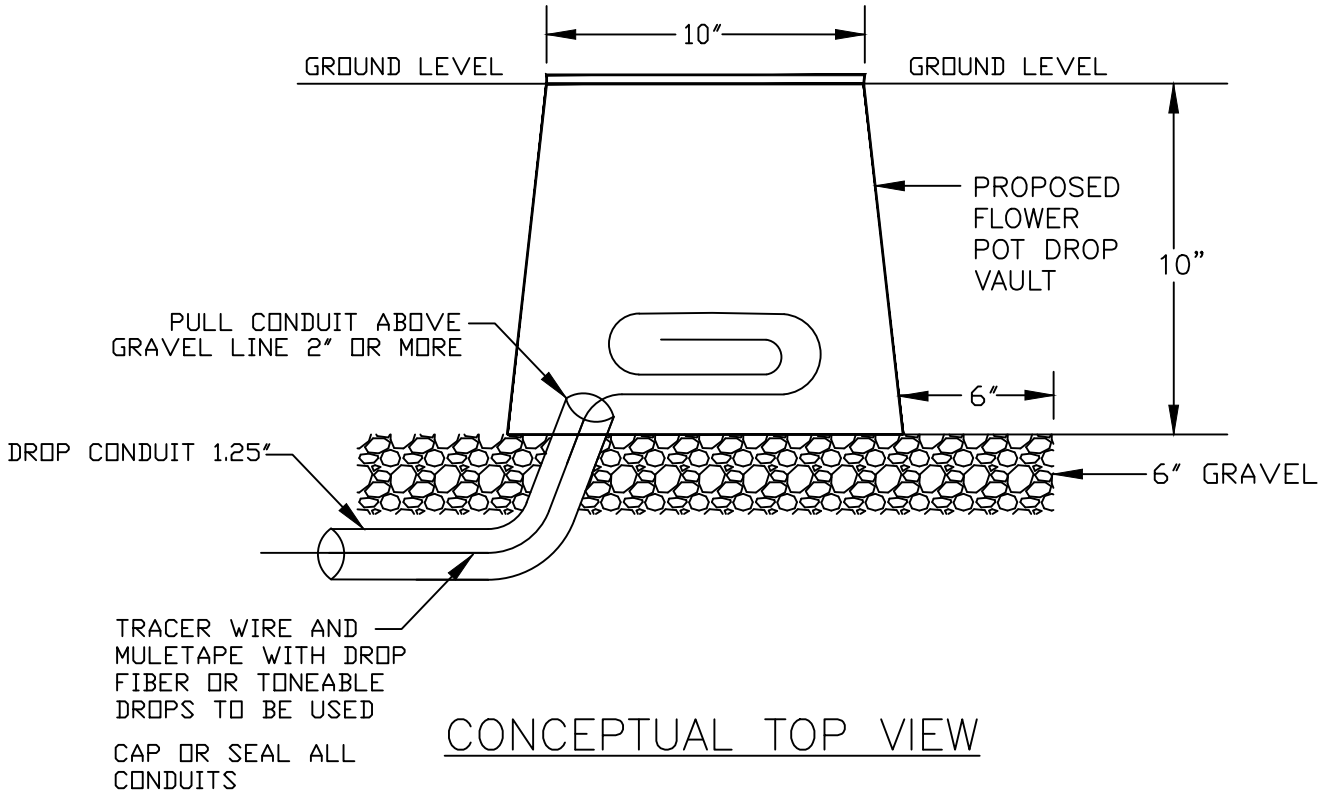

CONCEPTUAL TOP VIEW

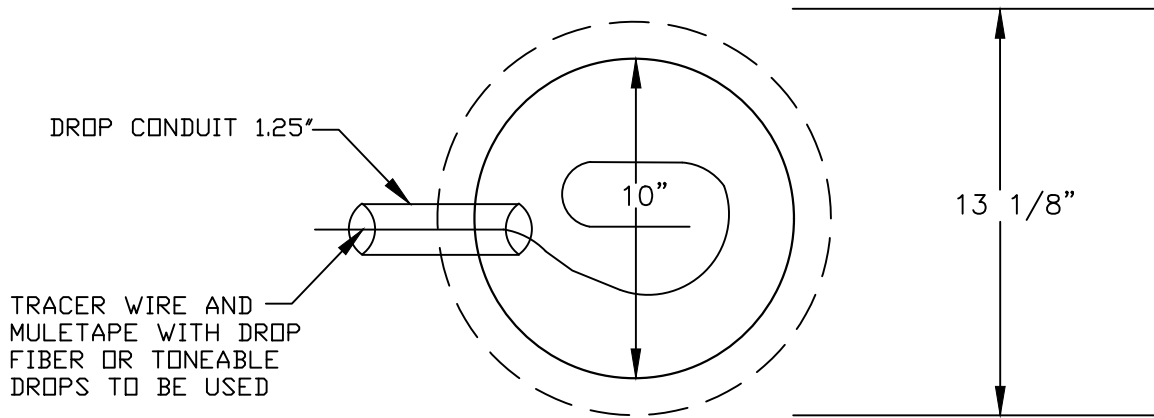

FLOWER POT

30"x48" PC UNIT, 2PC TIER 15/22
 18", 24", and 36" HEIGHT



AMERICAN POLYMER COMPANY

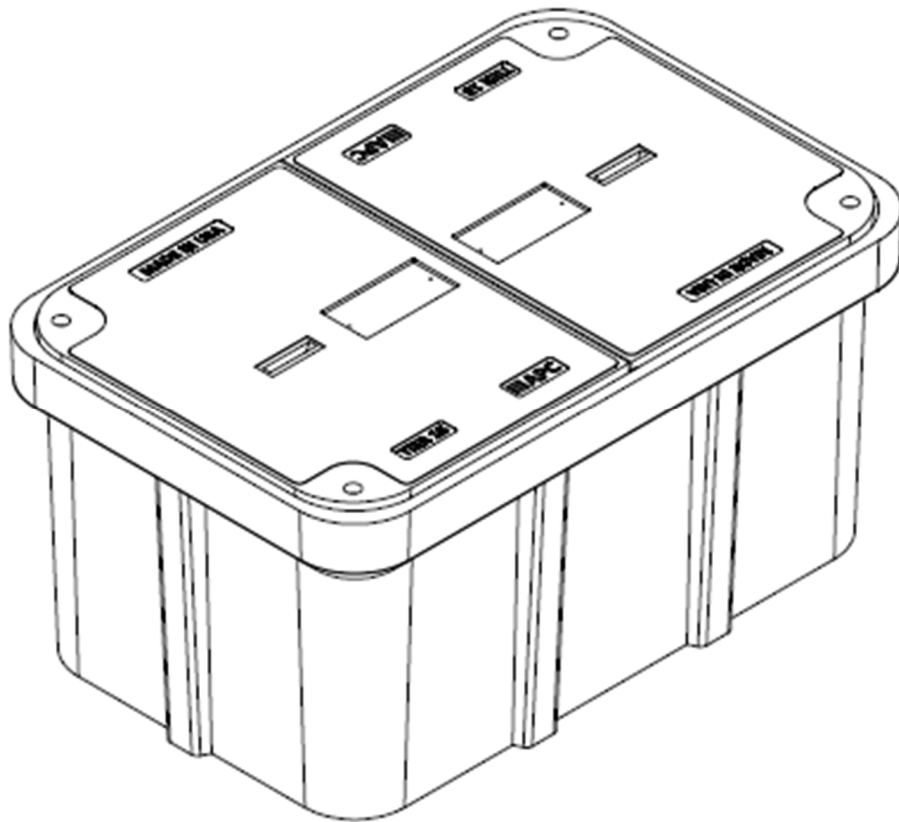

Description	Nominal Size	ANSI Tier	Part Number	Estimated Weight
PC Unit – TIER 15	30"x48"x18"	Tier 15	P304818HU15...	460 lbs.
PC Unit – TIER 22	30"x48"x18"	Tier 22	P304818HU22...	525 lbs.
PC Unit – TIER 15	30"x48"x24"	Tier 15	P304824HU15...	510 lbs.
PC Unit – TIER 22	30"x48"x24"	Tier 22	P304824HU22...	575 lbs.
PC Unit – TIER 15	30"x48"x36"	Tier 15	P304836HU15...	615 lbs.
PC Unit – TIER 22	30"x48"x36"	Tier 22	P304836HU22...	680 lbs.



30"x48" PC UNIT, 2PC TIER 15/22

18", 24", and 36" HEIGHT



AMERICAN POLYMER COMPANY

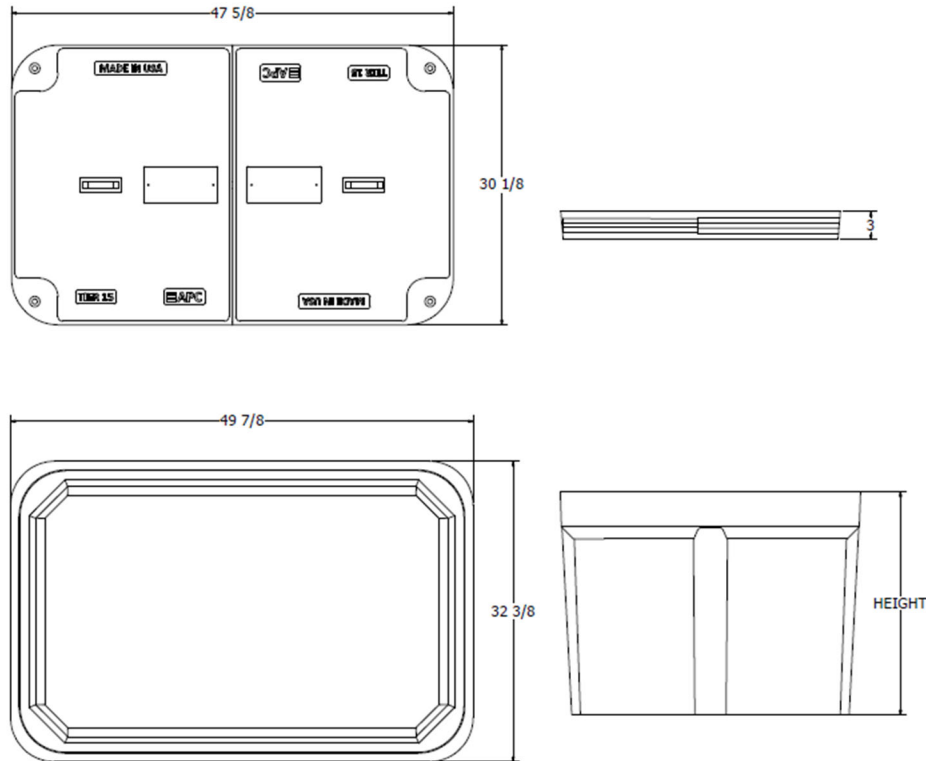

Components	Nominal Size	ANSI Tier	Part Number	Estimated Weight
Replacement Box	30"x48"x18"	Tier 22	P304818B22	185 lbs.
Replacement Box	30"x48"x24"	Tier 22	P304824B22	235 lbs.
Replacement Box	30"x48"x36"	Tier 22	P304836B22	340 lbs.
Replacement Lids - T15	30"x48" (half)	Tier 15	Various	150 lbs.
Replacement Lids - T22	30"x48" (half)	Tier 22	Various	170 lbs.

Bolt options



Machine Thread



Auger Thread



24"x36" PC UNIT, TIER 15/22
 18", 24", 30", and 36" HEIGHT



AMERICAN POLYMER COMPANY

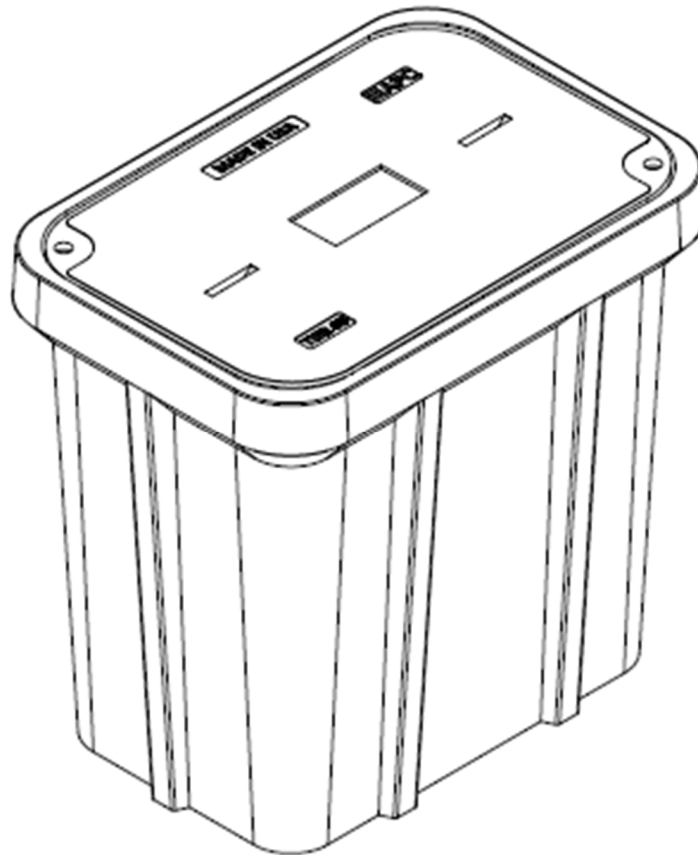

Description	Nominal Size	ANSI Tier	Part Number	Estimated Weight
PC Unit – TIER 15	24x36"x18"	Tier 15	P243618U15...	335 lbs.
PC Unit – TIER 22	24x36"x18"	Tier 22	P243618U22...	355 lbs.
PC Unit – TIER 15	24x36"x24"	Tier 15	P243624U15...	365 lbs.
PC Unit – TIER 22	24x36"x24"	Tier 22	P243624U22...	385 lbs.
PC Unit – TIER 15	24x36"x30"	Tier 15	P243630U15...	395 lbs.
PC Unit – TIER 22	24x36"x30"	Tier 22	P243630U22...	415 lbs.
PC Unit – TIER 15	24x36"x36"	Tier 15	P243636U15...	425 lbs.
PC Unit – TIER 22	24x36"x36"	Tier 22	P243636U22...	445 lbs.



24"x36" PC UNIT, TIER 15/22

18", 24", 30", and 36" HEIGHT



AMERICAN POLYMER COMPANY

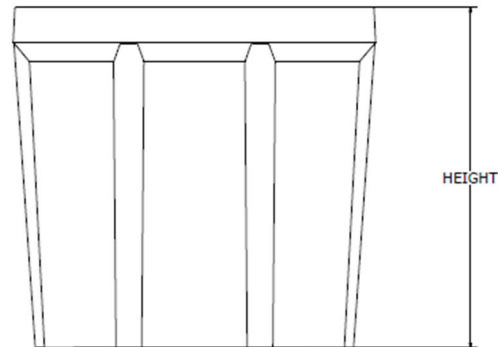
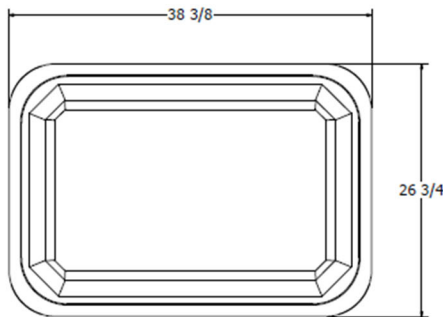
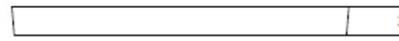
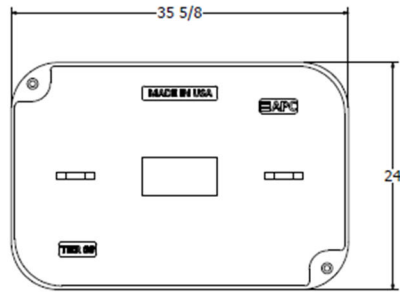

Components	Nominal Size	ANSI Tier	Part Number	Estimated Weight
Replacement Box	24"x36"x18"	Tier 22	P243618B22	165 lbs.
Replacement Box	24"x36"x24"	Tier 22	P243624B22	195 lbs.
Replacement Box	24"x36"x30"	Tier 22	P243630B22	225 lbs.
Replacement Box	24"x36"x36"	Tier 22	P243636B22	255 lbs.
Replacement Lids - T15	24"x36"	Tier 15	Various	170 lbs.
Replacement Lids - T22	24"x36"	Tier 22	Various	190 lbs.

Bolt options

Hex Head



Machine Thread



Penta Head



Auger Thread



17"x30" PC UNIT, TIER 15/22

12", 18", 24", and 30" HEIGHT



AMERICAN POLYMER COMPANY

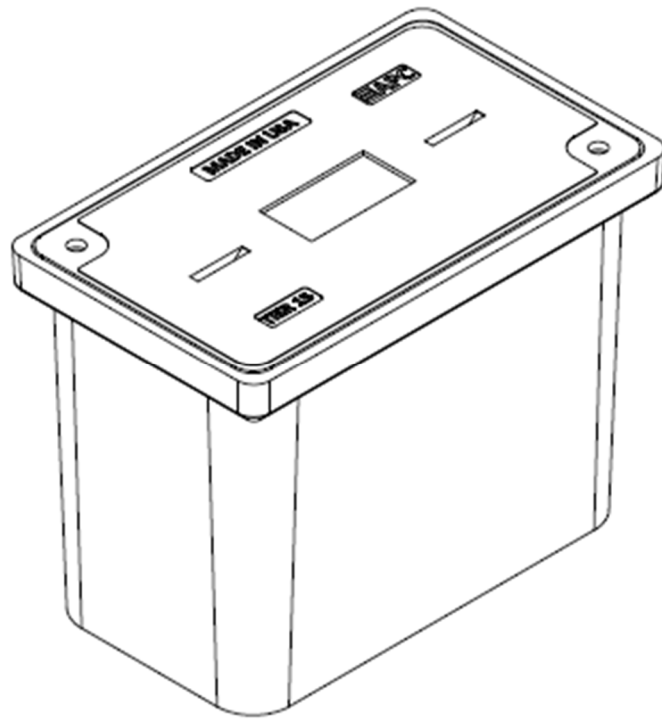

Description	Nominal Size	ANSI Tier	Part Number	Estimated Weight
PC Unit – TIER 15	17"x30"x12"	Tier 15	P173012U15...	138 lbs.
PC Unit – TIER 22	17"x30"x12"	Tier 22	P173012U22...	147 lbs.
PC Unit – TIER 15	17"x30"x18"	Tier 15	P173018U15...	172 lbs.
PC Unit – TIER 22	17"x30"x18"	Tier 22	P173018U22...	181 lbs.
PC Unit – TIER 15	17"x30"x24"	Tier 15	P173024U15...	192 lbs.
PC Unit – TIER 22	17"x30"x24"	Tier 22	P173024U22...	201 lbs.
PC Unit – TIER 15	17"x30"x30"	Tier 15	P173030U15...	217 lbs.
PC Unit – TIER 22	17"x30"x30"	Tier 22	P173030U22...	226 lbs.



17"x30" PC UNIT, TIER 15/22

12", 18", 24", and 30" HEIGHT



AMERICAN POLYMER COMPANY

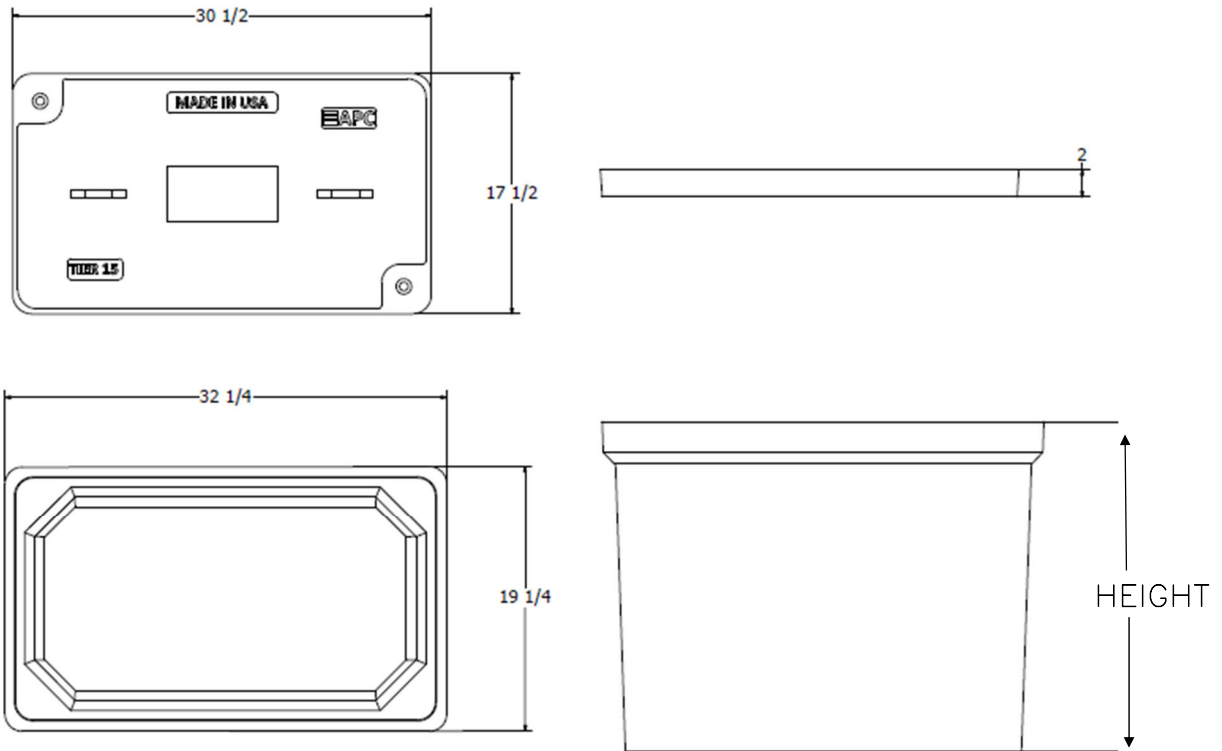

Components	Nominal Size	ANSI Tier	Part Number	Estimated Weight
Replacement Box	17"x30"x12"	Tier 22	P173012B22	66 lbs.
Replacement Box	17"x30"x18"	Tier 22	P173018B22	100 lbs.
Replacement Box	17"x30"x24"	Tier 22	P173024B22	120 lbs.
Replacement Box	17"x30"x30"	Tier 22	P173030B22	145 lbs.
Replacement Lids – T15	17"x30"	Tier 15	Various	72 lbs.
Replacement Lids – T22	17"x30"	Tier 22	Various	81 lbs.

Bolt options



Machine Thread



Auger Thread



33"x60" PC UNIT, 2PC TIER 15/22
36" HEIGHT



AMERICAN POLYMER COMPANY

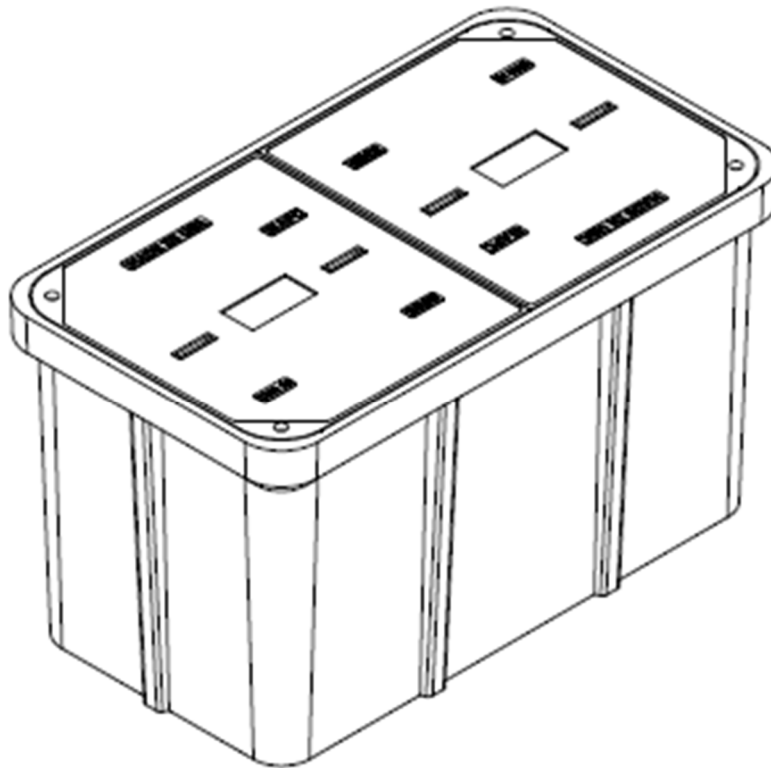

Description	Nominal Size	ANSI Tier	Part Number	Estimated Weight
PC Unit - TIER 15	33"x60"x36"	Tier 15	P336036U15...	930 lbs.
PC Unit - TIER 22	33"x60"x36"	Tier 22	P336036U22...	1030 lbs.



33"x60" PC UNIT, 2PC TIER 15/22

36" HEIGHT



AMERICAN POLYMER COMPANY

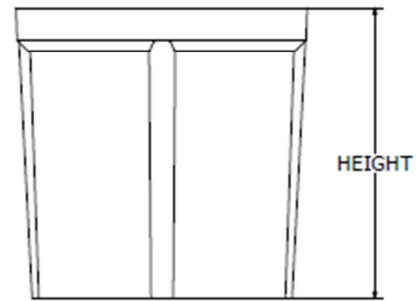
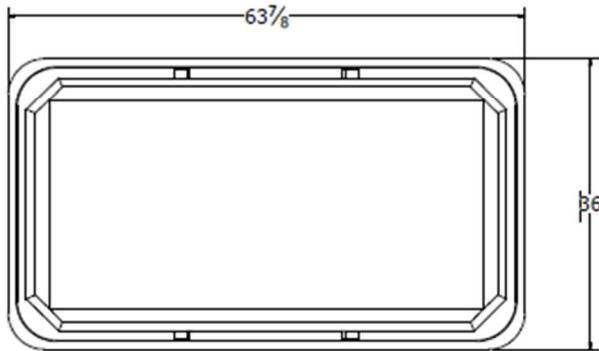
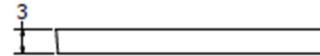
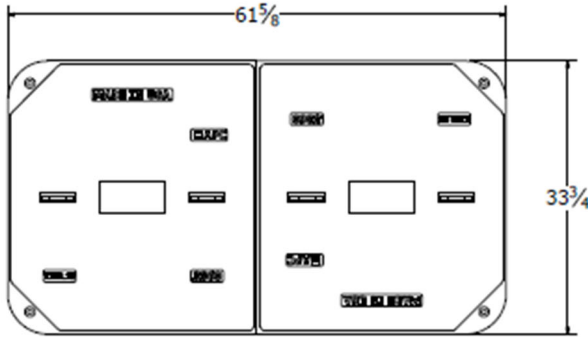

Components	Nominal Size	ANSI Tier	Part Number	Estimated Weight
Replacement Box	33"x60"x36"	Tier 22	P336036B22	530 lbs.
Replacement Lids - T15	33"x60" (half)	Tier 15	Various	200 lbs.
Replacement Lids - T22	33"x60" (half)	Tier 22	Various	250 lbs.

Bolt options

Hex Head



Machine Thread



Penta Head



Auger Thread



Speed (MPH) Prior To Road Work	SIGN SPACING, FT.		MUTCD Must be Approved by an Engineer				
	Non-Divided Highways	Divided Highways	BUFFER SPACE, FT.	TAPER LENGTH, FT.	CHANNELIZING SPACING, FT.		
	Length	Shoulder (10 ft. Width)	Lane (12 ft. Width)	Through Taper	Through Buffer/Work Area		
0-35	200	200	250	70	245	35	50
40-45	350	500	360	150	540	40	80
50-55	500	1000	495	185	660	50	100
60-70	SA-1000, SB-1500, SC-2640		730	235	840	60	120
Urban Low Speed - 100 FT							

APPROVED/ACCEPTED BY:
ENGINEER, OWNER, OR PRIME CONTRACTOR
 Check for Notice to Proceed.

Signature: _____

Company: _____

Date: 1/30/2024 **Project:** BLS01b-F09 N Pine St TCP1 :
Traffic Control Suggestion For: ATLANTIC ENGINEERING (AEG) :
By: Road Runner Safety Services, Inc. : Nathan

Comments:
 Drawing not to scale. Traffic control plan must be approved by an engineer. This is a suggestion only. Road Runners Safety Services, Inc. has no liability for this suggested traffic control plan. Actual placement and spacing of all traffic control devices will depend on field conditions and must conform to MUTCD standards.

- Legend**
- ADA Barricade
 - Arrow Board
 - Channelizer
 - Conduit
 - Flagger (Person)
 - Overhead Strand
 - Sign
 - Vault
 - Work Area

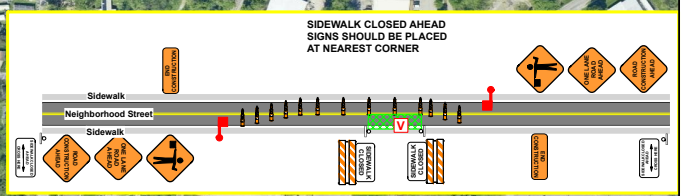
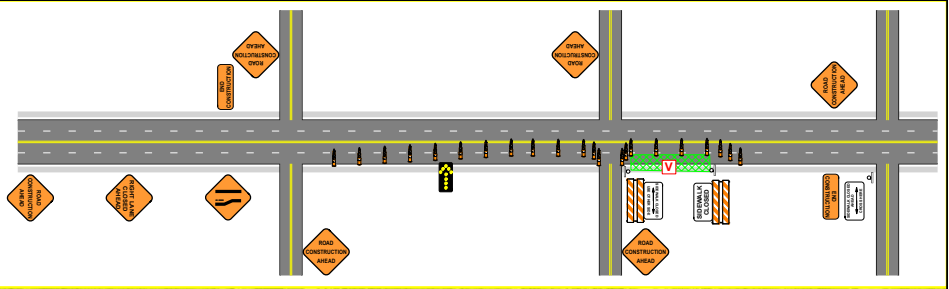
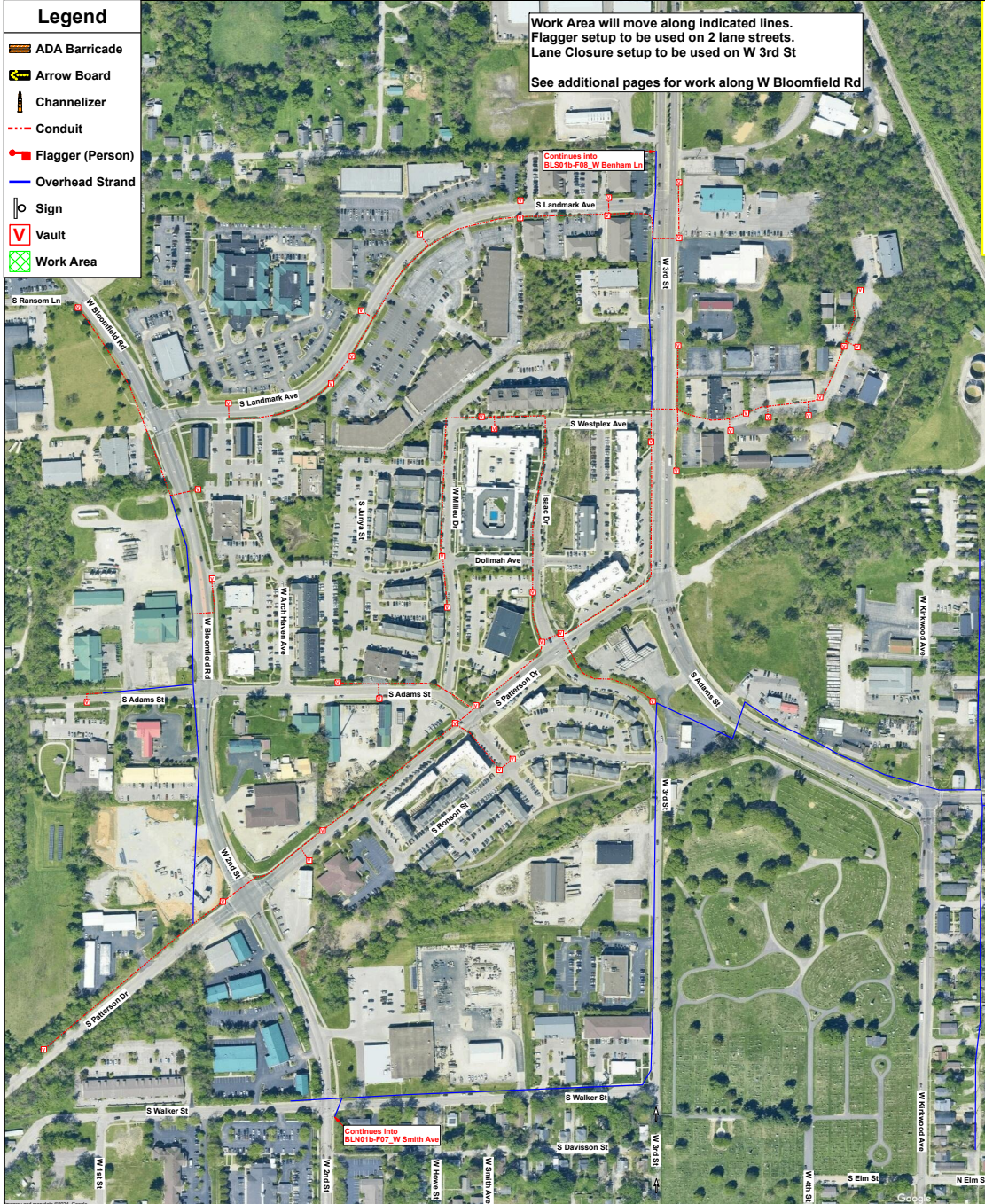

Speed (MPH) Prior To Road Work	SIGN SPACING, FT.		MUTCD Must be Approved by an Engineer				
	Non-Divided Highways	Divided Highways	BUFFER SPACE, FT.	TAPER LENGTH, FT.	CHANNELIZING SPACING, FT.		
	Length	Shoulder (10 ft. Width)	Lane (12 ft. Width)	Through Taper	Through Buffer/Work Area	Through Buffer/Work Area	
0-35	200	200	250	70	245	35	50
40-45	350	500	360	150	540	40	80
50-55	500	1000	495	185	660	50	100
60-70	SA-1000, SB-1500, SC-2640		730	235	840	60	120
Urban Low Speed - 100 FT							

APPROVED/ACCEPTED BY:
ENGINEER, OWNER, or PRIME CONTRACTOR
 Check for Notice to Proceed.

Signature: _____

Company: _____

Date: 1/30/2024 **Project:** BLS01b-F09 N Pine St TCP2 :
: **Traffic Control Suggestion For:** ATLANTIC ENGINEERING (AEG) :
By: Road Runner Safety Services, Inc. : Nathan

Comments:
Drawing not to scale. Traffic control plan must be approved by an engineer. This is a suggestion only. Road Runners Safety Services, Inc. has no liability for this suggested traffic control plan. Actual placement and spacing of all traffic control devices will depend on field conditions and must conform to MUTCD standards.

- Legend**
- Channelizer
 - Conduit
 - Overhead Strand
 - Vault
 - Work Area





CITY OF BLOOMINGTON RIGHT-OF-WAY USE PERMIT APPLICATION

401 N Morton Street, Suite 130
P.O. Box 100
Bloomington, IN 47402

Phone: (812) 349-3913
Fax: (812) 349-3520
Email:
engineering@bloomington.in.gov

ROW EXCAVATION ROW USE

ADDRESS OF ROW ACTIVITY: BLS01b-F09_N Pine St

A. APPLICANT/AGENT INFORMATION:		D. TRAFFIC CONTROL DEVICES*:	
APPLICANT NAME: <u>Bret Simons</u>		<input checked="" type="checkbox"/> CONES <input type="checkbox"/> ARROWBOARD	
E-MAIL: <u>bret.simons@aeg.cc</u>		<input type="checkbox"/> LIGHTED BARRELS <input checked="" type="checkbox"/> TYPE 3 BARRICADES	
COMPANY: <u>Atlantic Engineering Group</u>		<input checked="" type="checkbox"/> FLAGGERS <input type="checkbox"/> BPD OFFICER	
ADDRESS: <u>P.O. Box 349</u>		*PROVIDING MUTCD COMPLIANT TEMPORARY TRAFFIC CONTROL DEVICES AND MAINTENANCE OF TRAFFIC (MOT) PLAN IS YOUR RESPONSIBILITY AND REQUIRED. See page 3 for additional MOT resources; the graph paper can be used for your MOT site plan if needed or you can submit a separate sheet	
CITY, STATE, ZIP: <u>Buford, GA 30515</u>			
24-HR EMERGENCY CONTACT NAME: <u>(706)654-2298</u>		E. METERED PARKING SPACES NEEDED: <input type="checkbox"/> Y <input type="checkbox"/> N	
24-HR CONTACT PHONE #: _____		IT IS THE RESPONSIBILITY OF THE APPLICANT TO RESERVE PARKING METER(S) APPLICATION LOCATED: https://bloomington.in.gov/transportation/parking/moving OR CONTACT PARKING SERVICES WITH QUESTIONS AT (812)349-3436	
INSURANCE #*: <u>TB5-691-473497-082</u> COMPANY: <u>ACORD</u>		F. IS THIS A <input type="checkbox"/> CBU* <input type="checkbox"/> COUNTY* <input type="checkbox"/> IU* <input type="checkbox"/> NP* PROJECT?	
BOND #*: <u>1160465</u> COMPANY: <u>LEXON</u>		PROJECT NAME: <u>BLS01b-F09_N Pine St</u>	
*INSURANCE & BOND MUST BE ON FILE WITH THE CITY BEFORE PERMIT WILL BE ISSUED		PROJECT #: <u>BLS01b-F09_N Pine St</u>	
SUBCONTRACTOR INFORMATION		PROJECT MGR.: <u>Patrick Brigman</u>	
(LIST ALL COMPANIES WORKING UNDER PRIMARY CONTRACTOR PERMIT)		PROJECT MGR. #: <u>215-847-8819</u>	
COMPANY NAME: _____		*CBU = CITY OF BLOOMINGTON UTILITIES *COUNTY = MONROE COUNTY	
B. WORK DESCRIPTION:		*IU = INDIANA UNIVERSITY *NP = NOT-FOR-PROFIT AGENCY	
<input type="checkbox"/> POD/DUMPSTER <input type="checkbox"/> CRANE <input type="checkbox"/> SCAFFOLDING <input checked="" type="checkbox"/> CONSTRUCTION USE*		G. EXCAVATIONS:	
(EXPLAIN): <u>Excavation</u>		SQ FT OF PAVEMENT* EXCAVATIONS: <u>N/A</u>	
*EXCAVATION, LONG TERM USE FOR STORAGE OF MATERIAL/EQUIPMENT/WALKAROUND		*PAVEMENT INCLUDES: IN OR UNDER CONCRETE, OR ASPHALT INCLUDING CURBS	
C. RIGHT OF WAY TO BE USED/CLOSED:		SQ FT OF NON-PAVEMENT* EXCAVATIONS: <u>169.54 Sq Ft</u>	
STREET NAME 1: <u>N Pine St</u>		*DIRT, GRASS, GRAVEL, LANDSCAPE AREA OR OTHER UNPAVED SURFACE	
1ST INTERSECTING STREET NAME: _____		LINEAL FT OF BORE*: <u>11,237 Lineal Ft</u>	
2ND INTERSECTING STREET NAME: _____		*BORE PITS SHALL BE CALCULATED AS SQ FT EXCAVATIONS	
<input type="checkbox"/> ROAD CLOSURE <input checked="" type="checkbox"/> LANE CLOSURE 1 <input checked="" type="checkbox"/> 2 <input type="checkbox"/> 3 <input type="checkbox"/>		# OF POLE INSTALLATIONS/REMOVAL: <u>N/A</u>	
<input checked="" type="checkbox"/> SIDEWALK* <input type="checkbox"/> BIKE LANE <input type="checkbox"/> OTHER		SQ FT OF SIDEWALK RECONSTRUCTION*: <u>N/A</u>	
TRANSIT STOP? <input type="checkbox"/> Y <input type="checkbox"/> N PARKING LANE(S)** <input type="checkbox"/> Y <input type="checkbox"/> N **NON-METERED		*CONCRETE OR ASPHALT SIDEWALK/PATH BEING IMPROVED/REPLACED	
START DATE: <u>Feb. 28th</u> END DATE: _____ # OF DAYS*: <u>30</u>		SQ FT OF SIDEWALK NEW CONSTRUCTION*: <u>N/A</u>	
STREET NAME 2: _____		*CONCRETE OR ASPHALT SIDEWALK/PATH THAT IS NEW INFRASTRUCTURE	
1ST INTERSECTING STREET NAME: _____		#RESIDENTIAL DRIVEWAY INSTALLATION: <u>N/A</u>	
2ND INTERSECTING STREET NAME: _____		 <p>TO SUBMIT A LOCATE REQUEST 24 HRS A DAY, 7 DAYS A WEEK CALL 811 OR 800-382-5544 CALL 2 WORKING DAYS BEFORE YOU DIG. IT'S THE LAW.</p>	
<input type="checkbox"/> ROAD CLOSURE <input type="checkbox"/> LANE CLOSURE 1 <input type="checkbox"/> 2 <input type="checkbox"/> 3 <input type="checkbox"/>			
<input type="checkbox"/> SIDEWALK* <input type="checkbox"/> BIKE LANE <input type="checkbox"/> OTHER		H. INDEMNIFICATION AGREEMENT:	
TRANSIT STOP? <input type="checkbox"/> Y <input type="checkbox"/> N PARKING LANE(S)** <input type="checkbox"/> Y <input type="checkbox"/> N **NON-METERED		The petitioner/applicant hereby agrees to hold harmless, defend and to indemnify the City of Bloomington from or against all claims, action, damages and expenses, including but not limited to reasonable attorney's fees or any alleged injury and/or death to any person or damage to any property arising, or alleged to have arisen out of any act of commission or omission on the part of the petitioner/applicant, his/her heirs, successors, or assigns regardless of whether such acts are the direct or indirect result of the public right-of-way use pursuant to this permit grant.	
START DATE: _____ END DATE: _____ # OF DAYS*: _____		I AFFIRM, UNDER THE PENALTIES FOR PERJURY, THAT THE FOREGOING REPRESENTATIONS ARE TRUE.	
*SIDEWALK CLOSURES FOR A PERIOD OR PERIODS TOTALING 24HRS OR MORE SHALL INSTALL A WALKAROUND UNLESS OTHERWISE APPROVED DURING REVIEW		PRINT NAME: <u>Bret Simons</u>	
STANDARD CLOSURE HOURS MON-FRI*: 9:00 AM - 3:00 PM & 6:00 PM - 9:00 PM		SIGNATURE: <u>Bret Simons</u>	
STANDARD CLOSURE HOURS <input checked="" type="checkbox"/> *NON-STANDARD CLOSURE HOURS <input type="checkbox"/>		DATE: <u>2/5/2024</u>	
REQUESTED CLOSURE HOURS: _____ AM - _____ PM			
*non-standard hours may not be allowed near schools, on arterials, or other circumstances and are subject to approval during the permitting process			
BMC 14.09.040 allows work from 6 AM to 10 PM without violating the noise ordinance (7AM to 9PM for pneumatic hammers)			

For Administration Use Only (applicable to CLOSURE approval)

Approved By: _____ BPW City Engineer Director Date: _____

Staff Representative: _____ Phone#: _____ Date: _____

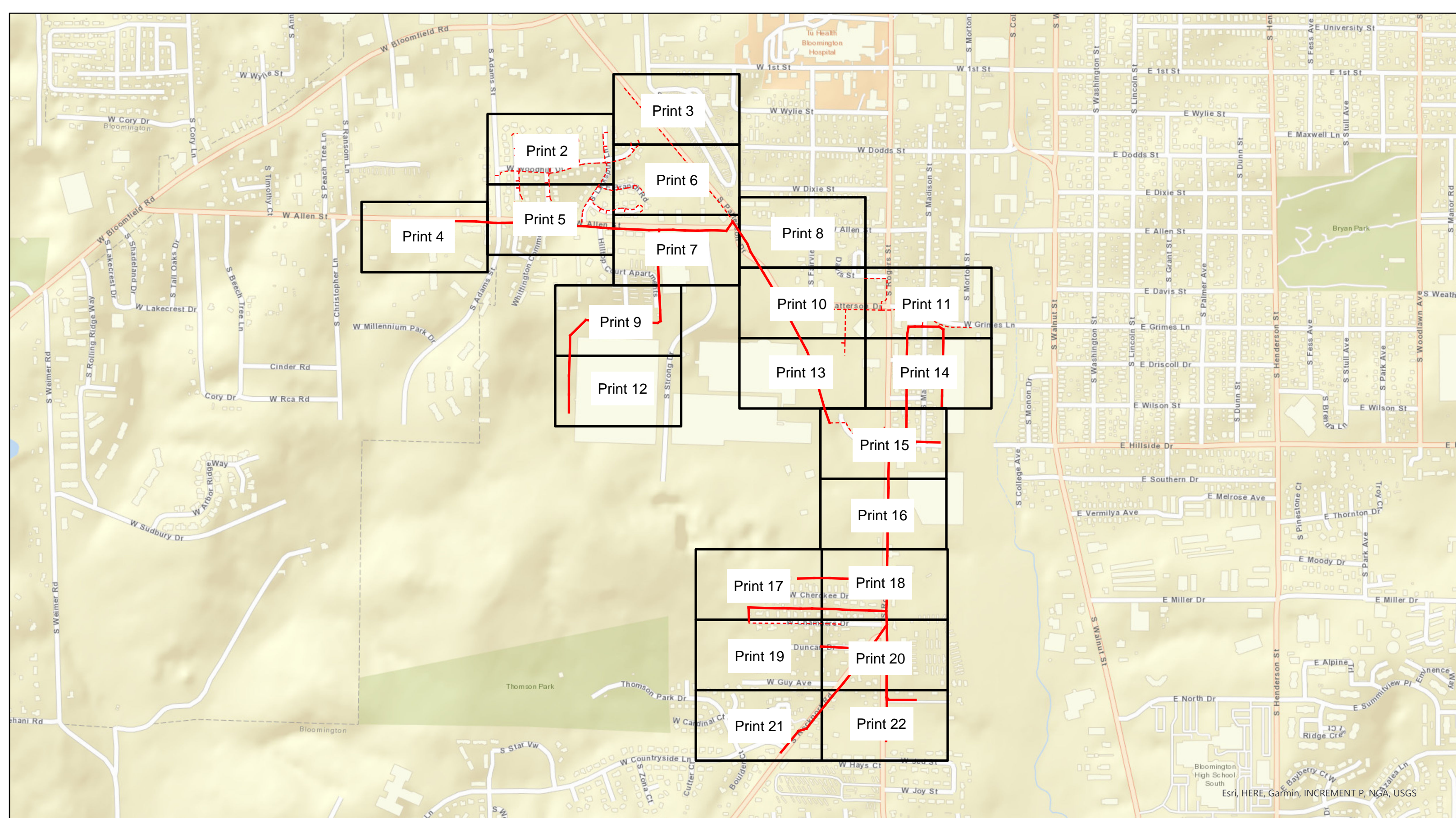

Esri, HERE, Garmin, INCREMENT P, NGA, USGS



Legend BLS01a-F07_S Strong St

- Overhead Strand
- - - Conduit
- Grids



City of Bloomington, IN Permit:
Design View

INI	BY	DATE	DESCRIPTION

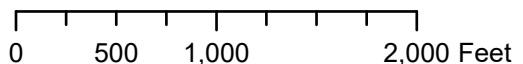

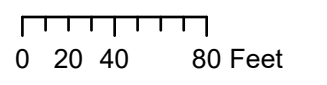
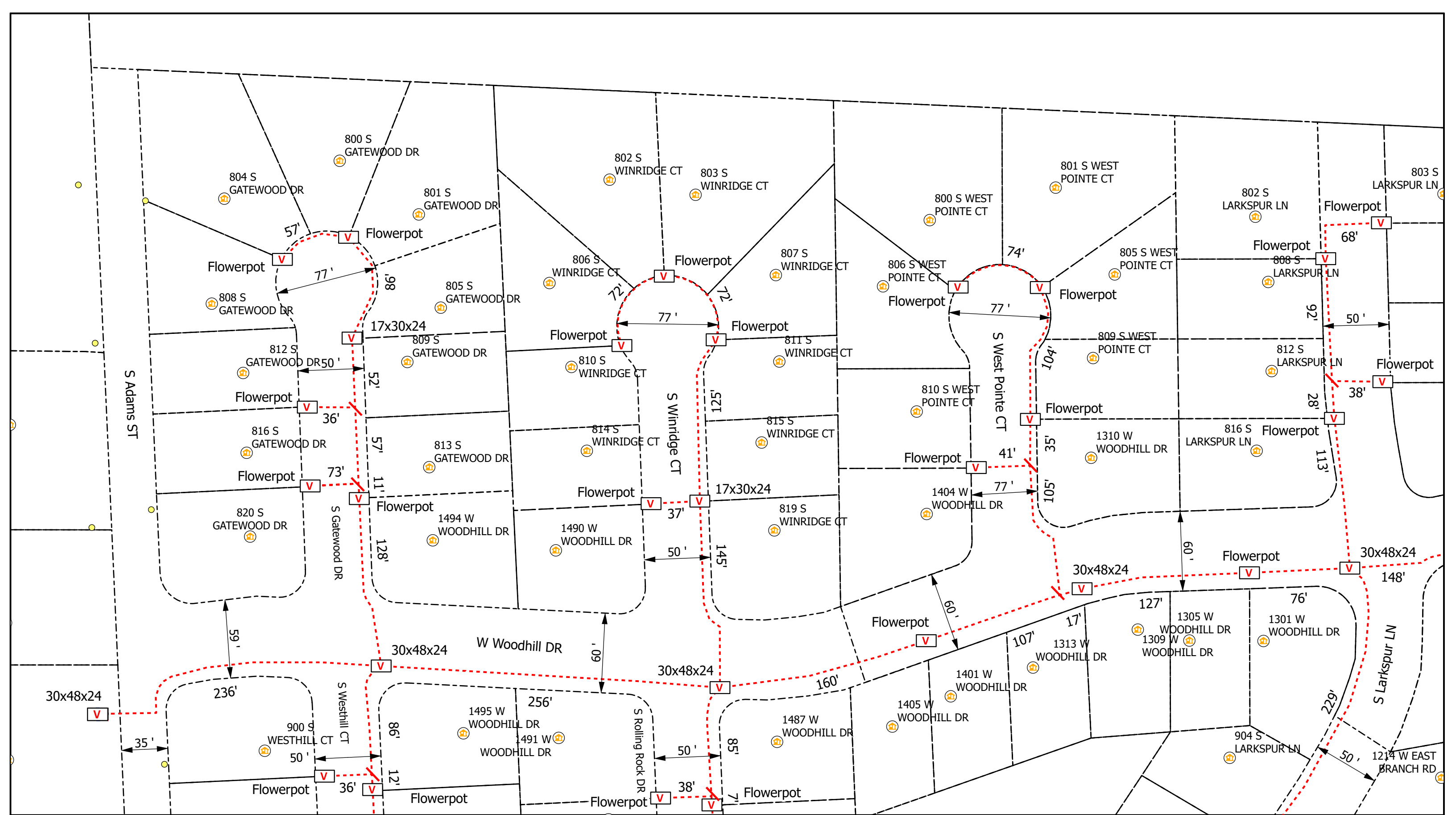

Legend

- Poles
- V Vaults
- Overhead Strand
- Conduit
- R Risers
- Ⓜ Address
- Y Anchor
- ↖ Sidewalk
- Bloomington_Parcels
- Grids

All Flowerpots 12" DIA



City of Bloomington, IN Permit:
Design View

INI	BY	DATE	DESCRIPTION



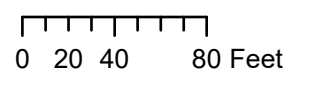
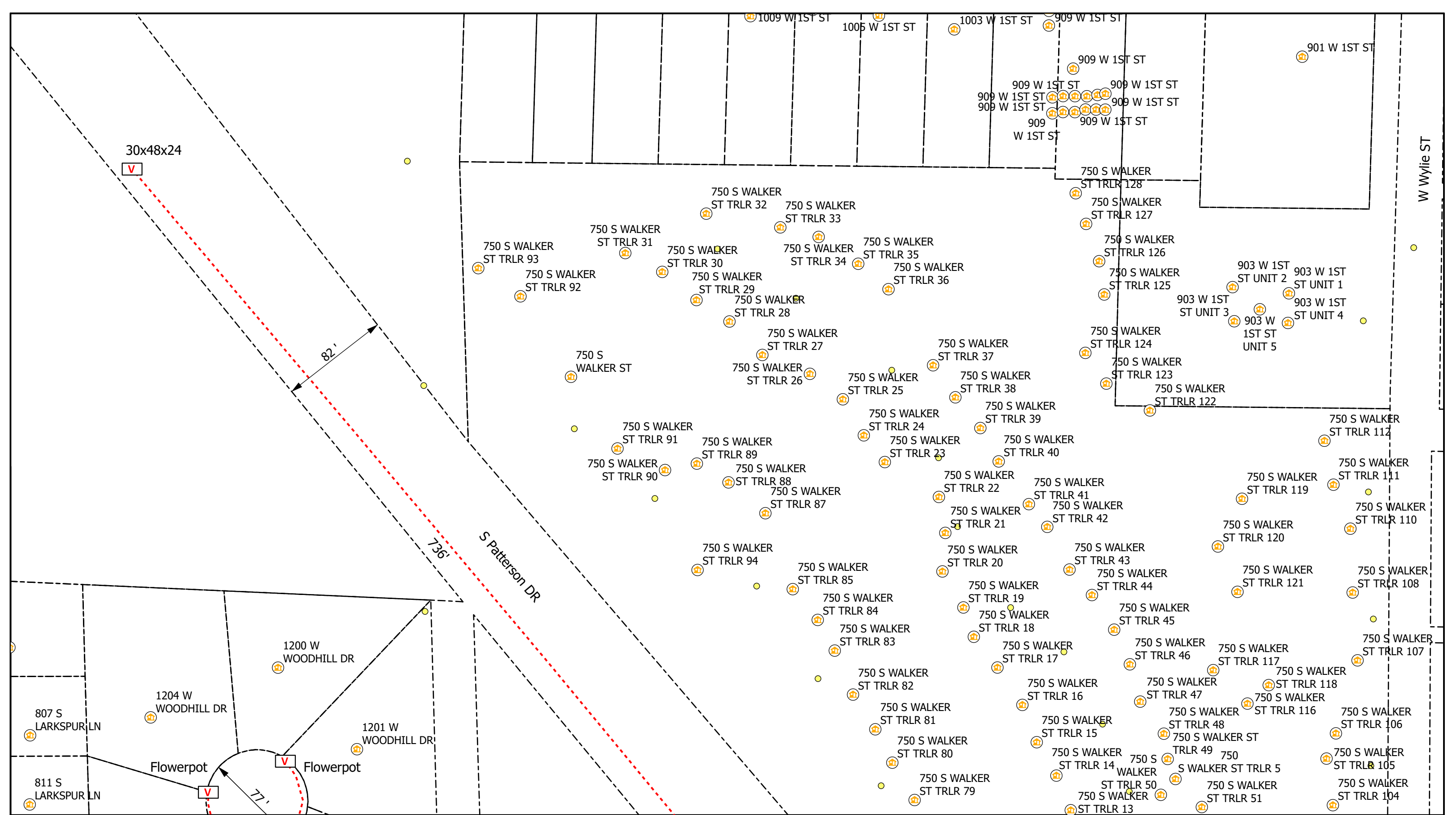

Legend

- Poles
- V Vaults
- Overhead Strand
- - - Conduit
- Ⓡ Risers
- Ⓜ Address
- Y Anchor
- ↖ Sidewalk
- Bloomington_Parcels
- Grids

All Flowerpots 12" DIA



City of Bloomington, IN Permit:
Design View

INI	BY	DATE	DESCRIPTION



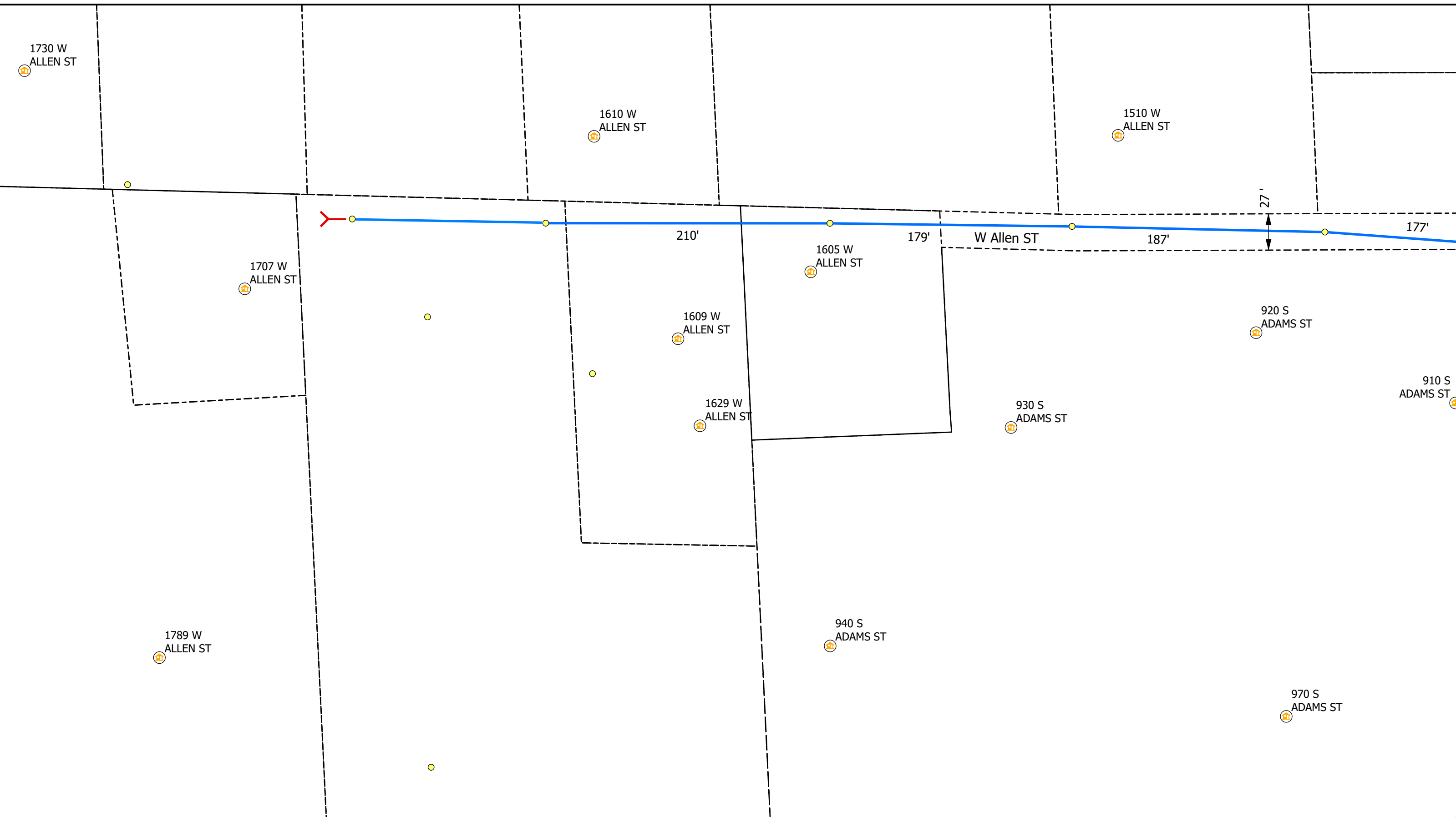

0 20 40 80 Feet

Legend

- Poles
- V Vaults
- Overhead Strand
- Conduit
- Ⓡ Risers
- Ⓜ Address
- Y Anchor
- └ Sidewalk
- Bloomington_Parcels
- Grids

All Flowerpots 12" DIA

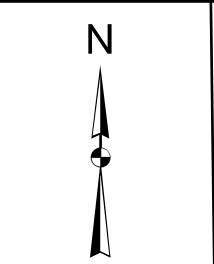

City of Bloomington, IN Permit:
Design View

INI	BY	DATE	DESCRIPTION

Print 4 of 22

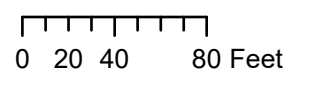
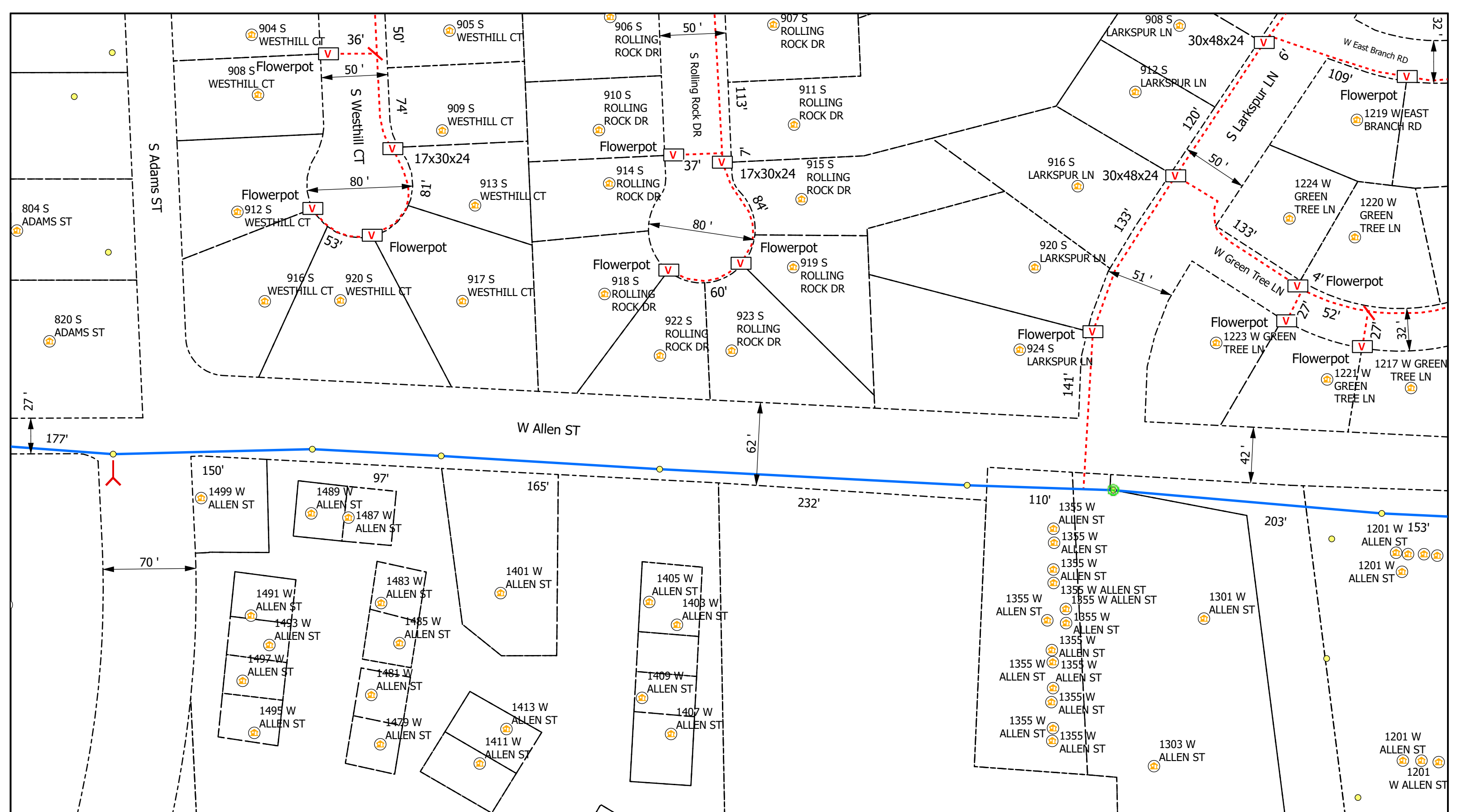

Legend

- Poles
- V Vaults
- Overhead Strand
- Conduit
- R Risers
- Ⓜ Address
- Y Anchor
- └ Sidewalk
- Bloomington_Parcels
- Grids

All Flowerpots 12" DIA



City of Bloomington, IN Permit:
Design View

INI	BY	DATE	DESCRIPTION



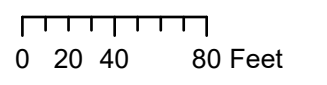
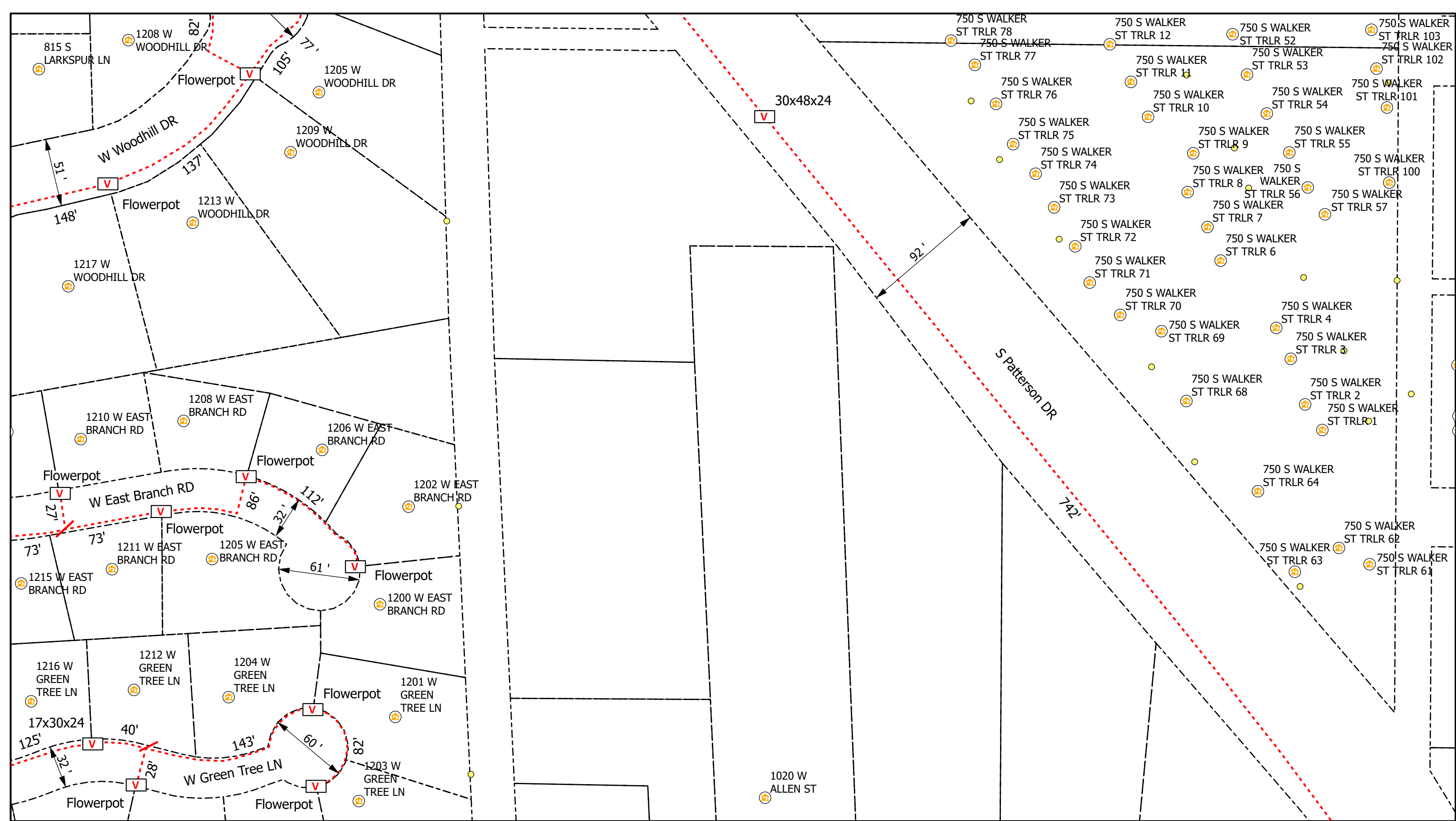

Legend

- Poles
- Ⓡ Risers
- Ⓜ Sidewalk
- V Vaults
- 🏠 Address
- Bloomington_Parcels
- Overhead Strand
- Conduit
- Y Anchor
- Grids

All Flowerpots 12" DIA



City of Bloomington, IN Permit:
Design View

INI	BY	DATE	DESCRIPTION



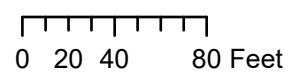
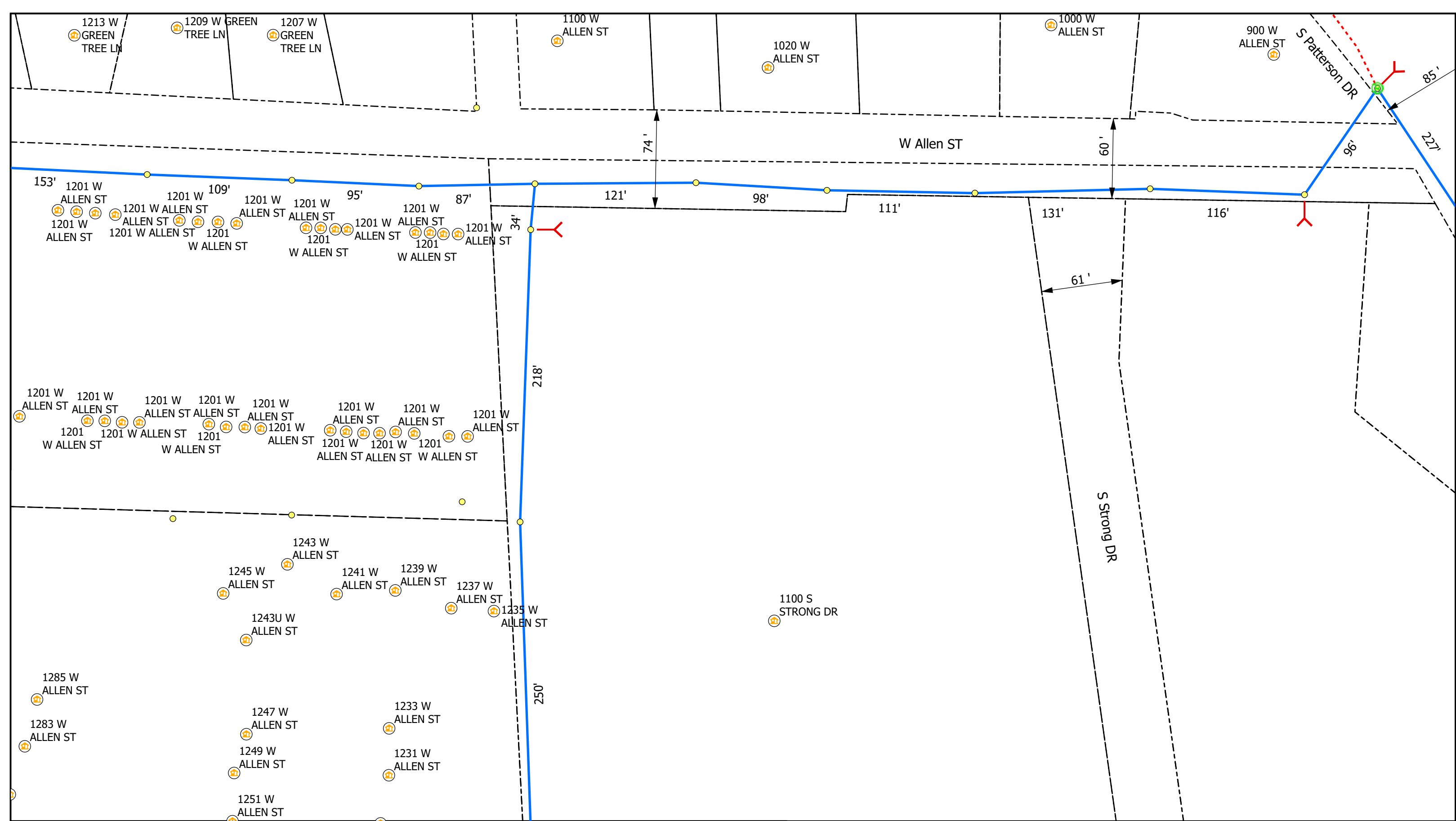

Legend

- Poles
- Ⓡ Risers
- ⌞ Sidewalk
- V Vaults
- 🏠 Address
- Bloomington_Parcels
- Overhead Strand
- Y Anchor
- - - Conduit
- Grids

All Flowerpots 12" DIA



City of Bloomington, IN Permit:
Design View

INI	BY	DATE	DESCRIPTION



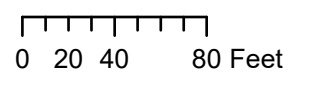

Legend

- Poles
- Risers
- Y Anchor
- V Vaults
- Y Address
- Conduit
- └─┘ Sidewalk
- Bloomington_Parcels
- Grids

All Flowerpots 12" DIA



City of Bloomington, IN Permit:
Design View

INI	BY	DATE	DESCRIPTION



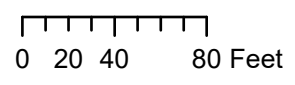
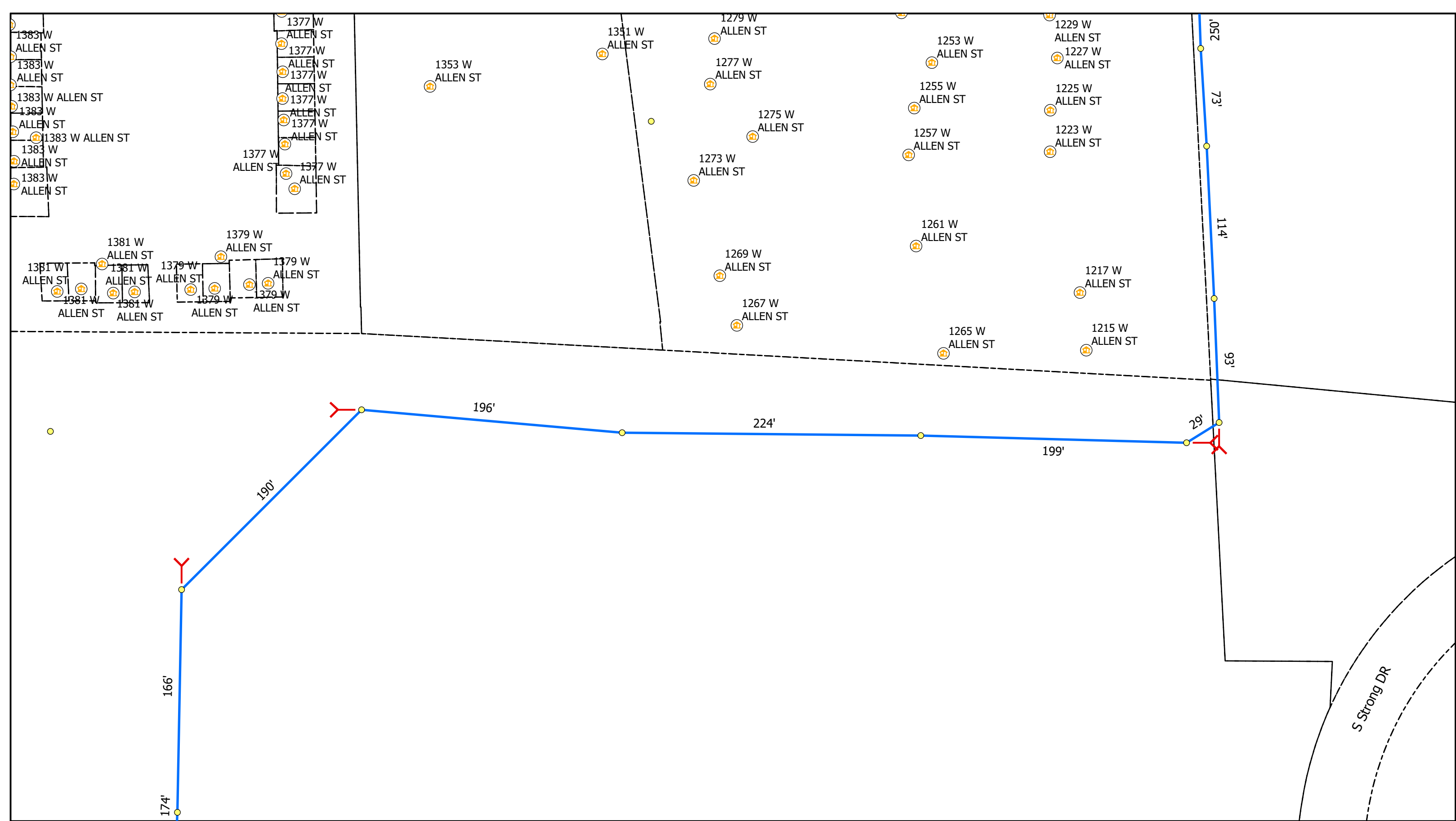

Legend

- Poles
- Ⓜ Risers
- V Vaults
- 🏠 Address
- Overhead Strand
- Y Anchor
- ⤴ Sidewalk
- Bloomington_Parcels
- Grids
- ⋯ Conduit

All Flowerpots 12" DIA



City of Bloomington, IN Permit:
Design View

INI	BY	DATE	DESCRIPTION



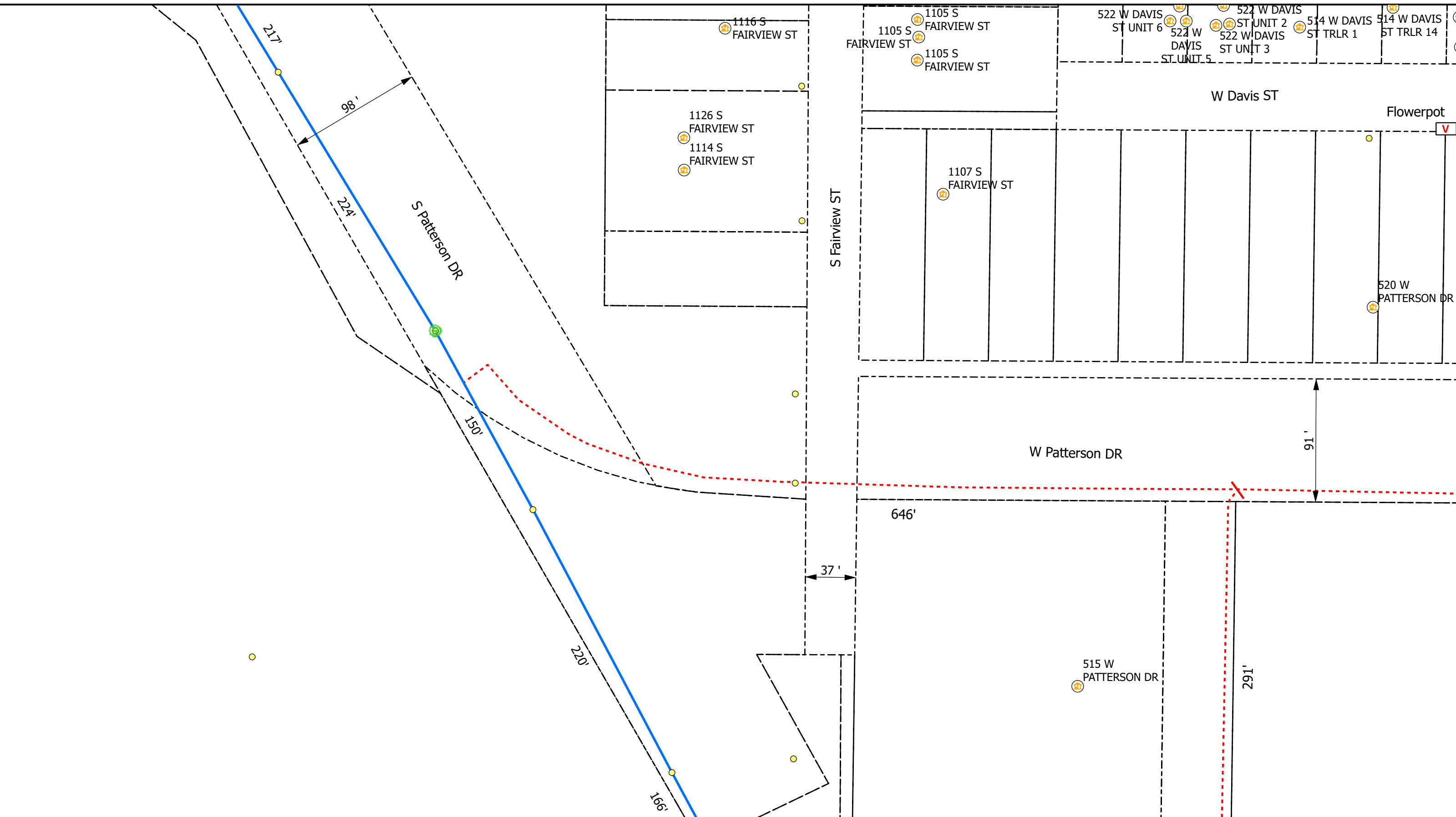

Legend

- Poles
- Risers
- Anchor
- Vaults
- Address
- Sidewalk
- Overhead Strand
- Conduit
- Bloomington_Parcels
- Grids

All Flowerpots 12" DIA

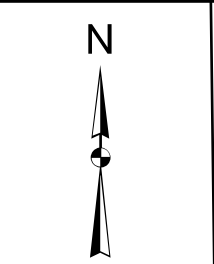

City of Bloomington, IN Permit:
Design View

INI	BY	DATE	DESCRIPTION

Print 10 of 22

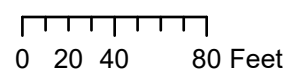
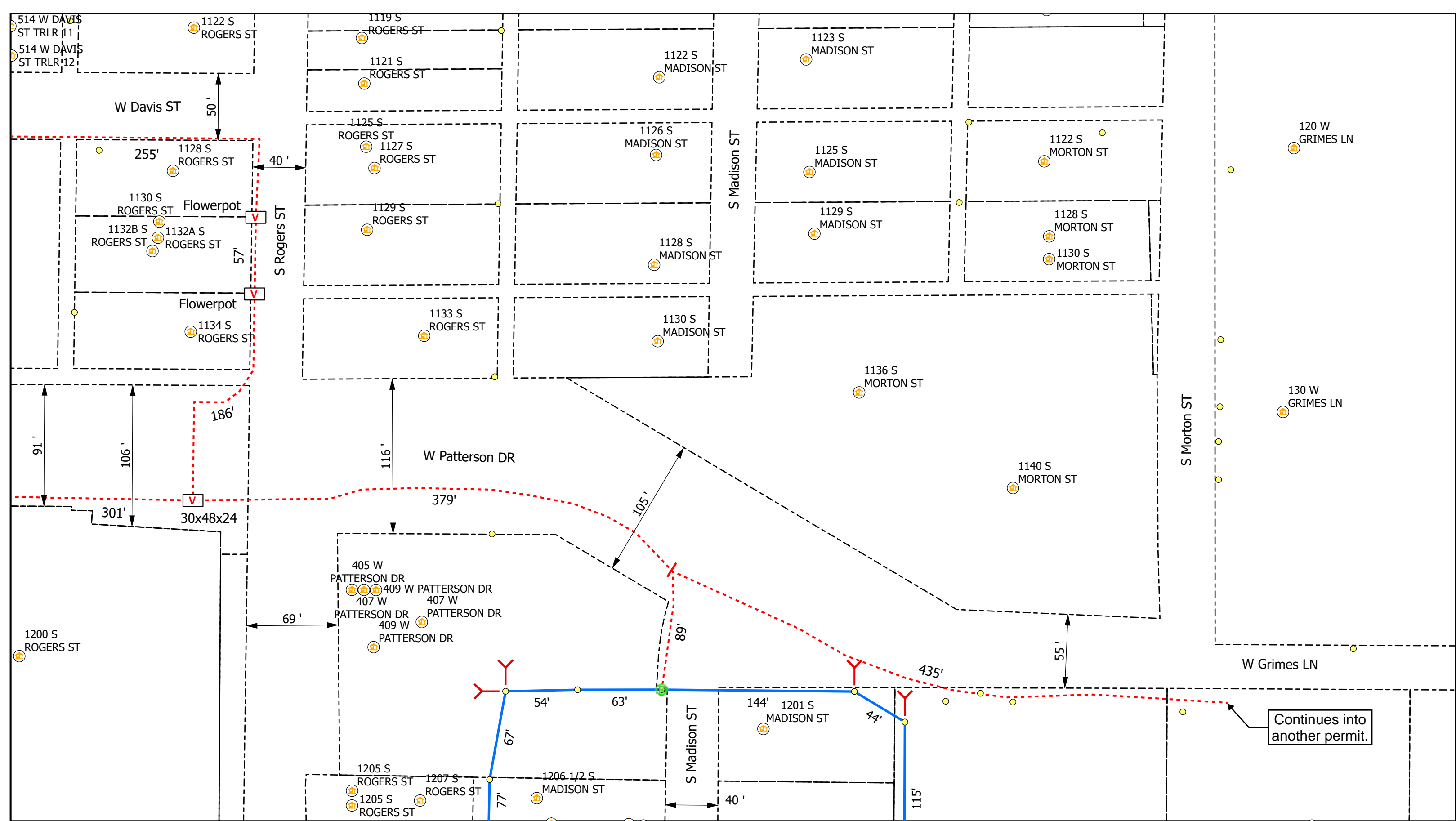

Legend

- Poles
- V Vaults
- Overhead Strand
- Conduit
- R Risers
- A Address
- Y Anchor
- ⤴ Sidewalk
- Bloomington_Parcels
- Grids

All Flowerpots 12" DIA



City of Bloomington, IN Permit:
Design View

INI	BY	DATE	DESCRIPTION



174'
165'
152'

1500 S
STRONG DR

S Strong DR



0 20 40 80 Feet

Legend

- Poles
- Ⓡ Risers
- Ⓜ Address
- Y Anchor
- V Vaults
- Overhead Strand
- - - Conduit
- ↖ Sidewalk
- Bloomington_Parcels
- Grids

All Flowerpots 12" DIA



City of Bloomington, IN Permit:
Design View

INI	BY	DATE	DESCRIPTION



1300 S
PATTERSON DR

1320 S
ROGERS ST

17x30x24 V 40'

17x30x24

166'

106'

23'

200'

200'

107'

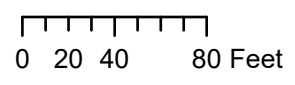

Legend

- Poles
- Ⓡ Risers
- ⌞ Sidewalk
- V Vaults
- 🏠 Address
- Bloomington_Parcels
- Overhead Strand
- Y Anchor
- - - Conduit
- Grids

All Flowerpots 12" DIA



City of Bloomington, IN Permit:
Design View

INI	BY	DATE	DESCRIPTION



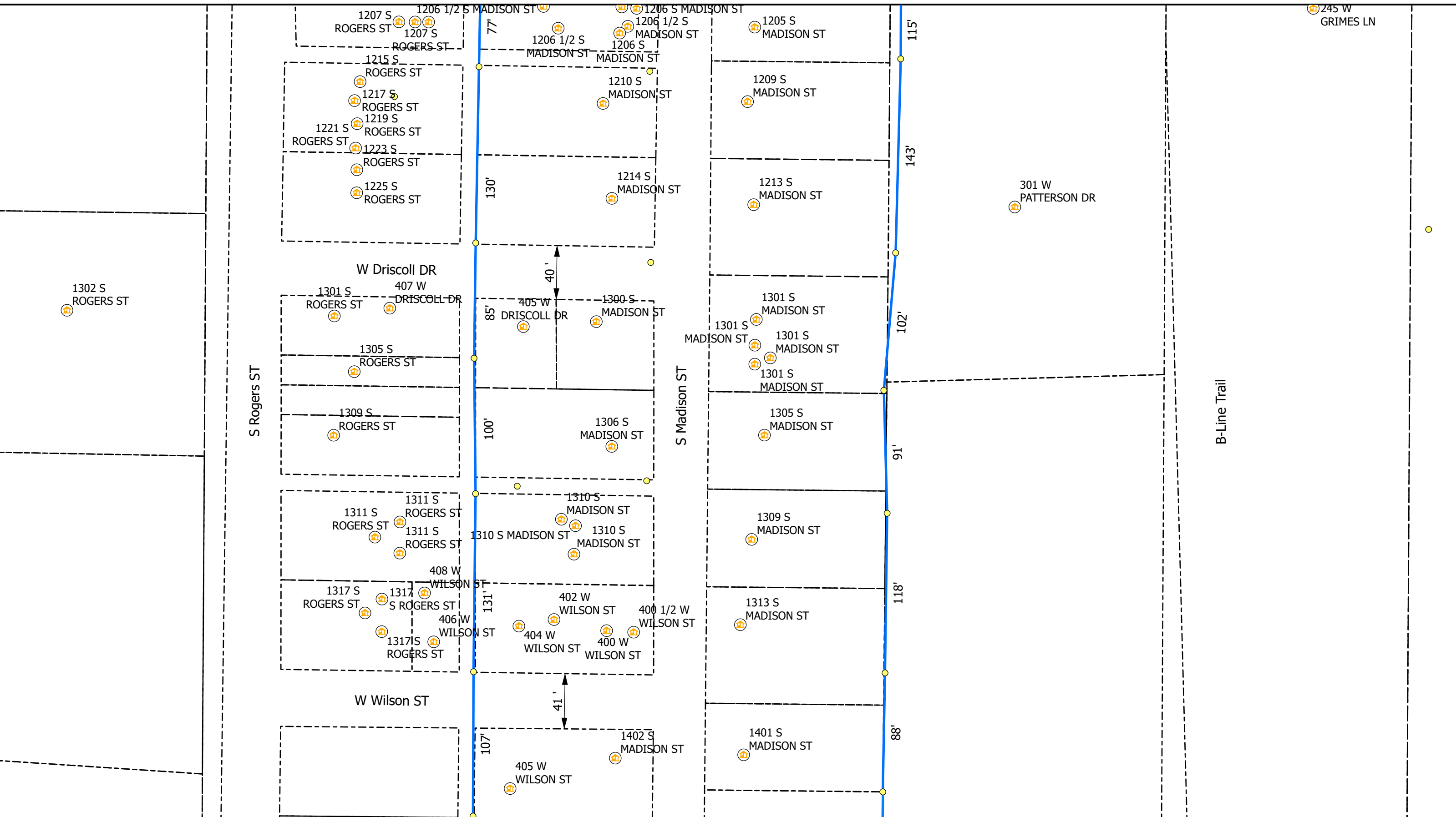

0 20 40 80 Feet

Legend

- Poles
- Ⓜ Vaults
- Overhead Strand
- - - Conduit
- Ⓜ Risers
- 🏠 Address
- ⚓ Anchor
- ↖ Sidewalk
- ⌚ Bloomington_Parcels
- ▭ Grids

All Flowerpots 12" DIA

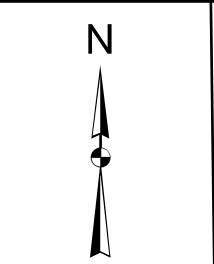

City of Bloomington, IN Permit:
Design View

INI	BY	DATE	DESCRIPTION

Print 14 of 22

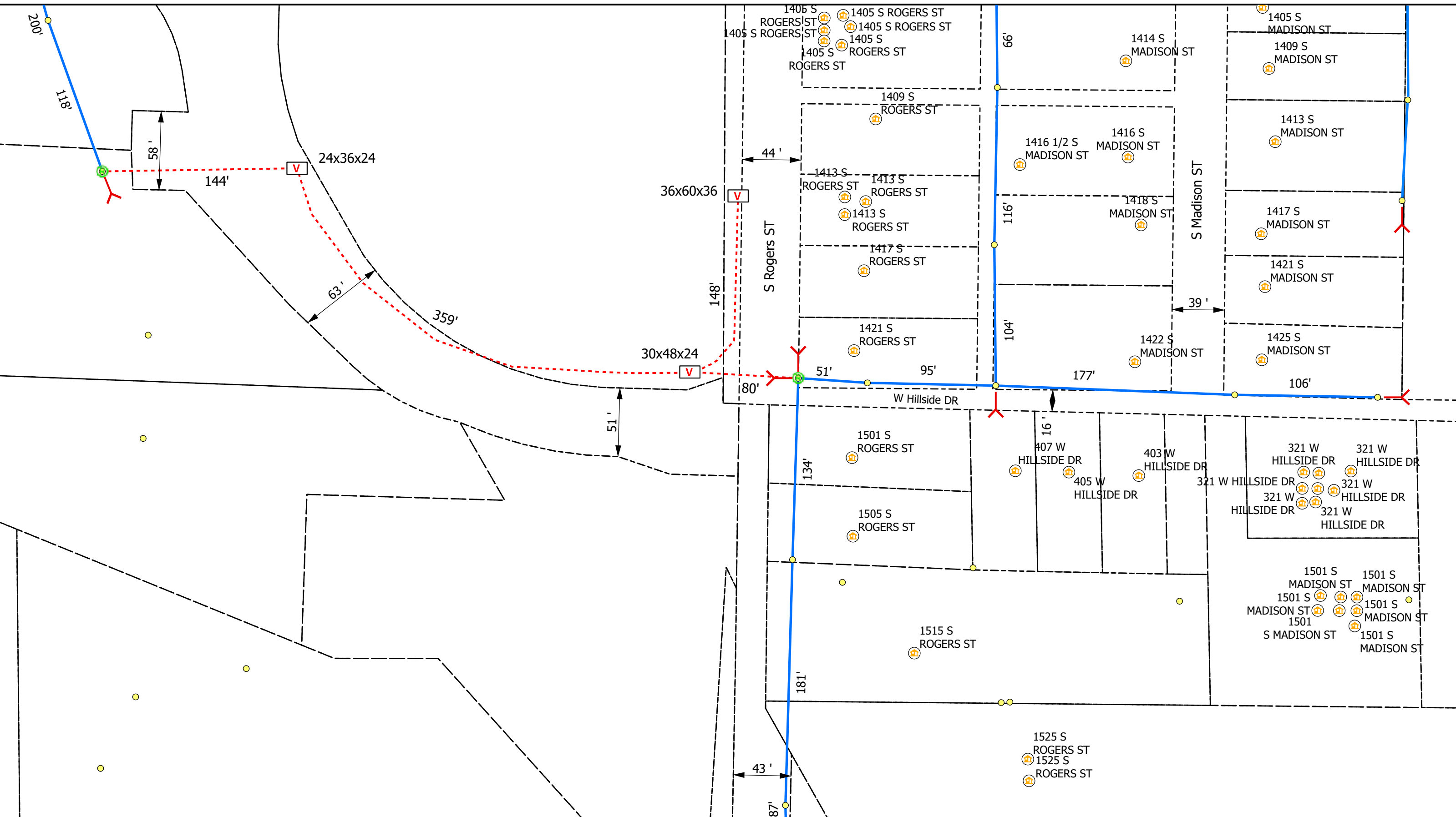

Legend

- Poles
- Ⓡ Risers
- Ⓜ Address
- Ⓜ Anchor
- V Vaults
- Overhead Strand
- - - Conduit
- ↖ Sidewalk
- Bloomington_Parcels
- Grids

All Flowerpots 12" DIA

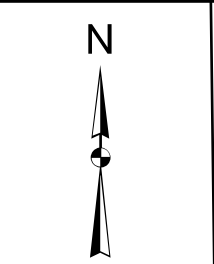

City of Bloomington, IN Permit:
Design View

INI	BY	DATE	DESCRIPTION

Print 15 of 22

1523 S
ROGERS ST

1525 S
ROGERS ST

1527 S
ROGERS ST

1529 S
ROGERS ST

1531 S
ROGERS ST

1533 S
ROGERS ST

1535 S
ROGERS ST

1537 S
ROGERS ST

1604 S
ROGERS ST
1606 S
ROGERS ST

S Rogers ST

87'

42'

131'

150'

62'

217'

89'



0 20 40 80 Feet

Legend

- Poles
- Ⓡ Risers
- ⌞ Sidewalk
- V Vaults
- 🏠 Address
- Bloomington_Parcels
- Overhead Strand
- Y Anchor
- - - Conduit
- Grids

All Flowerpots 12" DIA

N



City of Bloomington, IN Permit:
Design View

INI	BY	DATE	DESCRIPTION



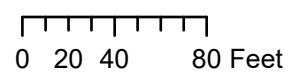
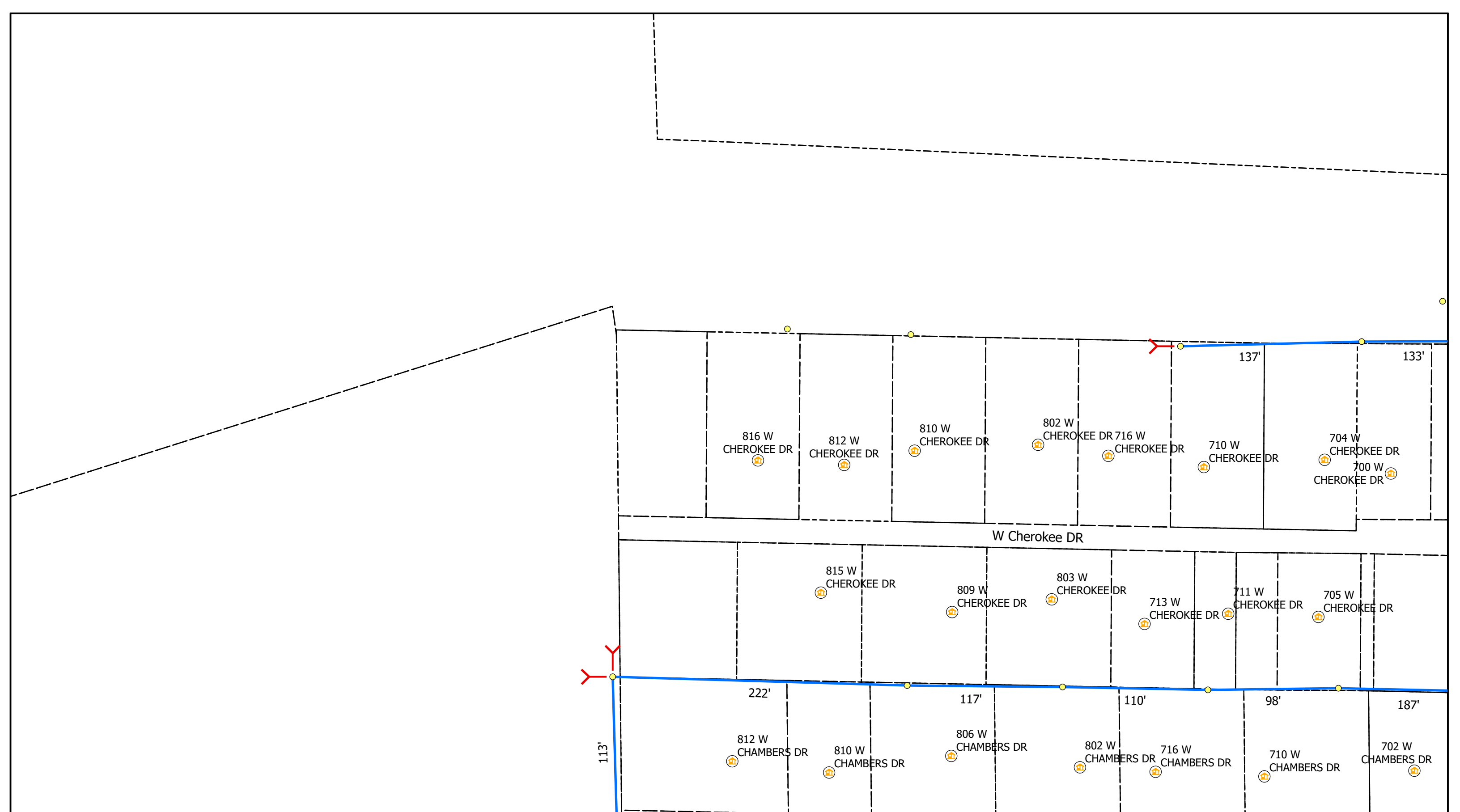

Legend

- Poles
- Ⓡ Risers
- Ⓜ Sidewalk
- V Vaults
- 🏠 Address
- Bloomington_Parcels
- Overhead Strand
- Y Anchor
- Grids
- - - Conduit

All Flowerpots 12" DIA



City of Bloomington, IN Permit:
Design View

INI	BY	DATE	DESCRIPTION



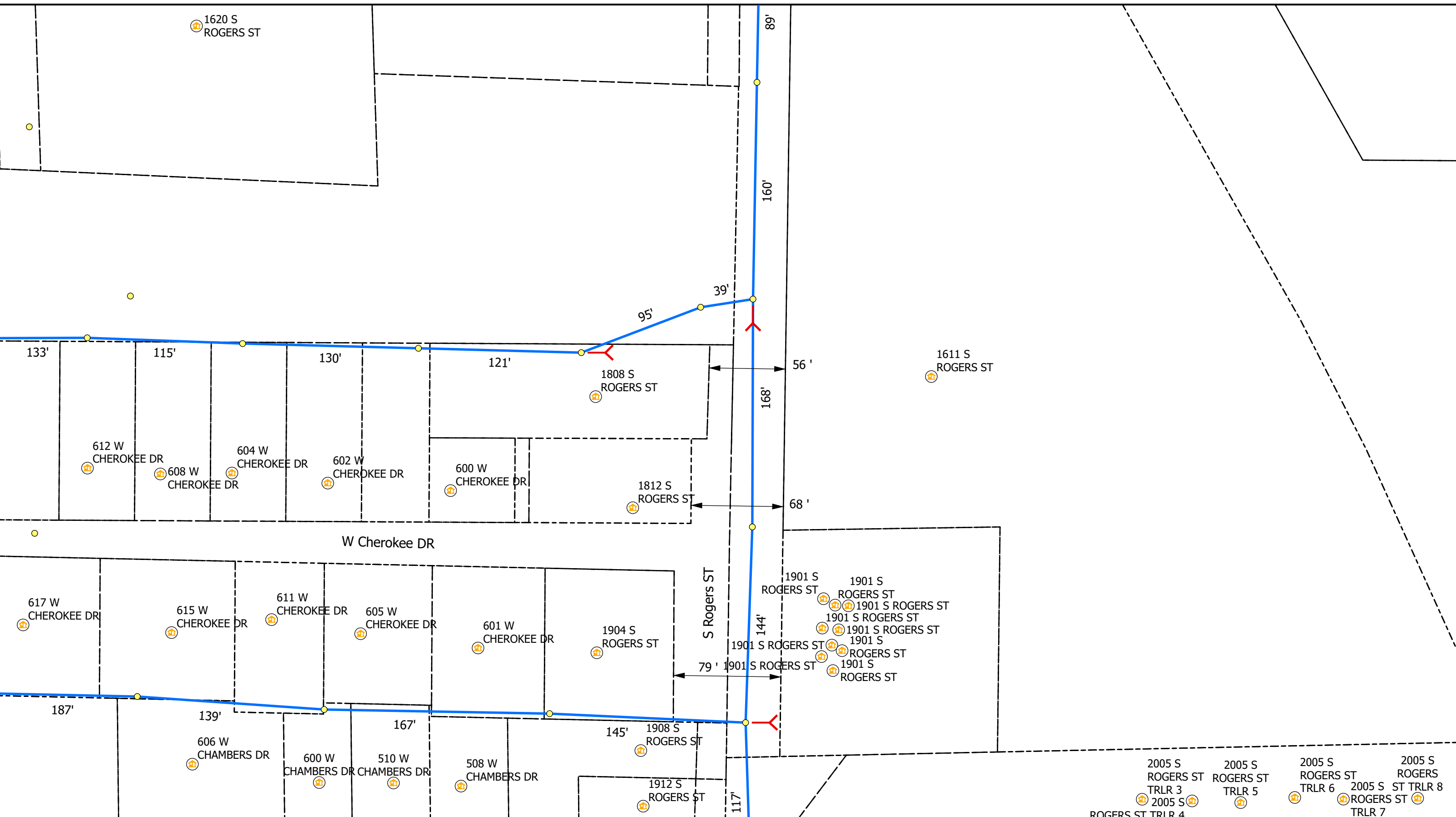

Legend

- Poles
- V Vaults
- Overhead Strand
- Conduit
- Ⓡ Risers
- 🏠 Address
- Y Anchor
- └ Sidewalk
- Bloomington_Parcels
- Grids

All Flowerpots 12" DIA

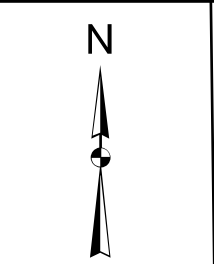

City of Bloomington, IN Permit:
Design View

INI	BY	DATE	DESCRIPTION

Print 18 of 22

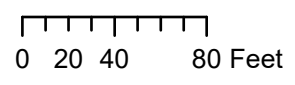
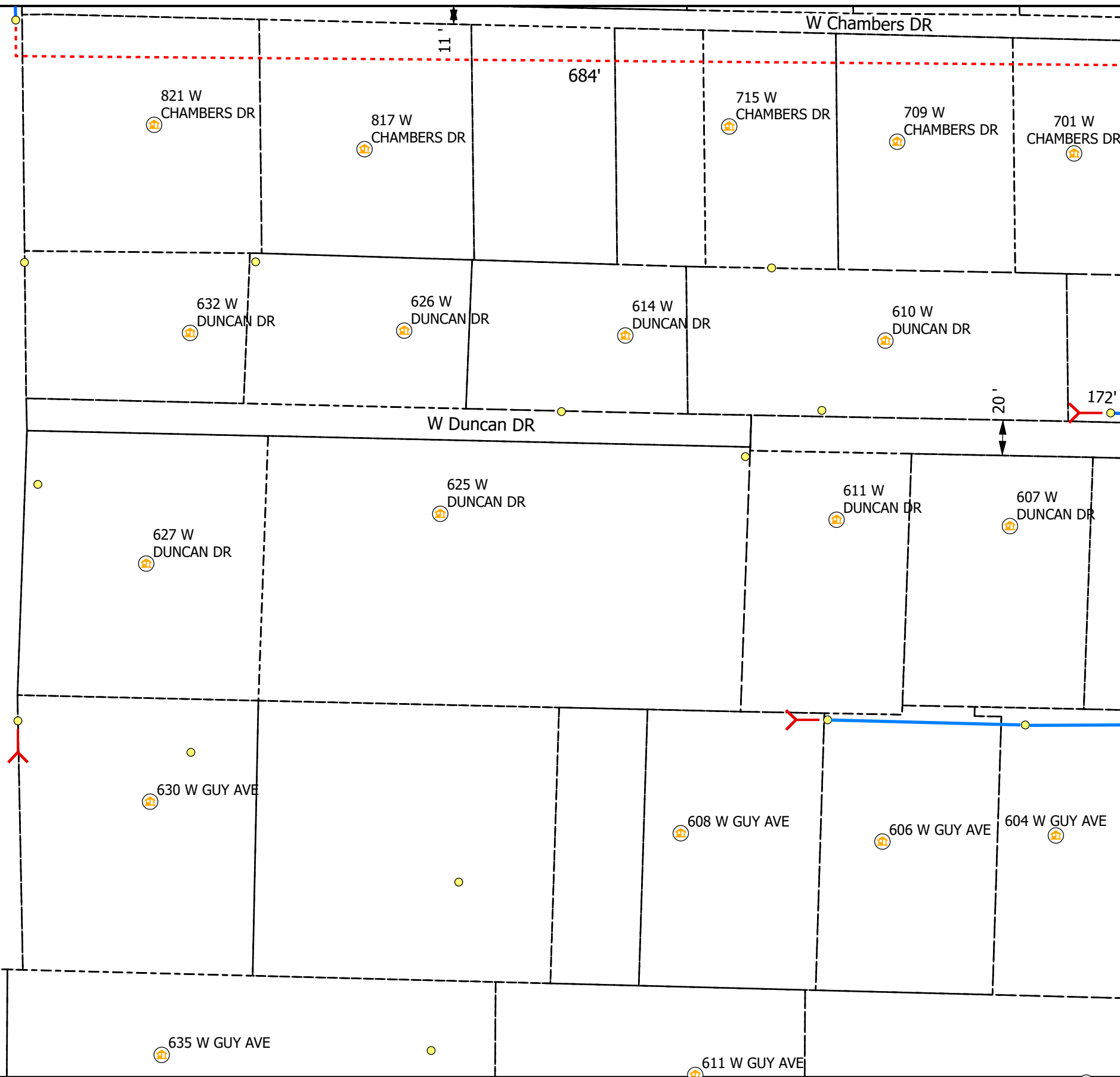

Legend

- Poles
- V Vaults
- Overhead Strand
- - - Conduit
- Ⓡ Risers
- Ⓜ Address
- Y Anchor
- └ Sidewalk
- Bloomington_Parcels
- Grids

All Flowerpots 12" DIA



City of Bloomington, IN Permit:
Design View

INI	BY	DATE	DESCRIPTION



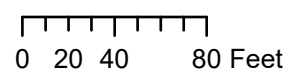
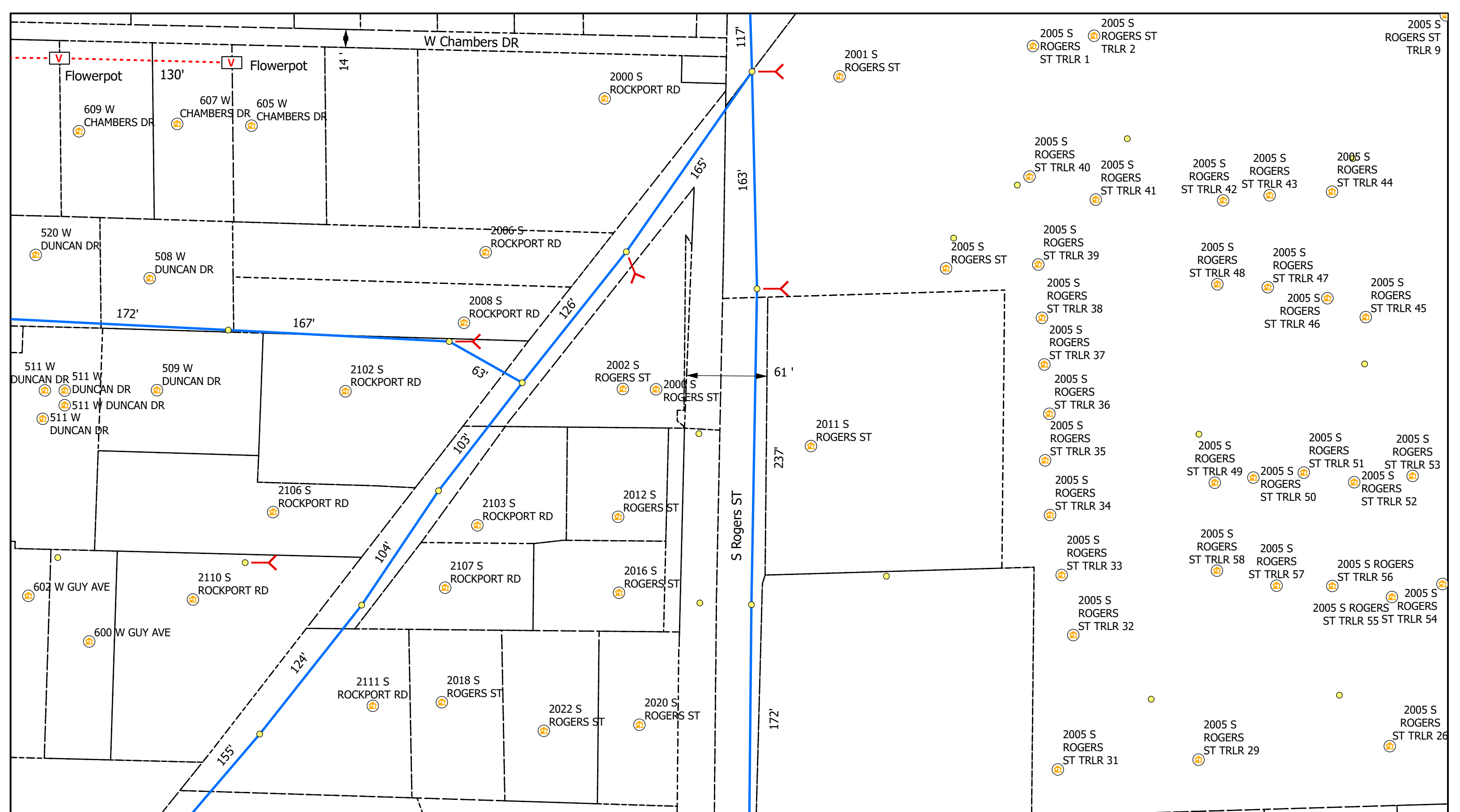

Legend

- Poles
- Ⓡ Risers
- Ⓜ Sidewalk
- V Vaults
- Ⓜ Address
- Ⓜ Bloomington_Parcels
- Overhead Strand
- Conduit
- Y Anchor
- Grids

All Flowerpots 12" DIA



City of Bloomington, IN Permit:
Design View

INI	BY	DATE	DESCRIPTION



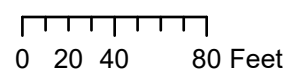
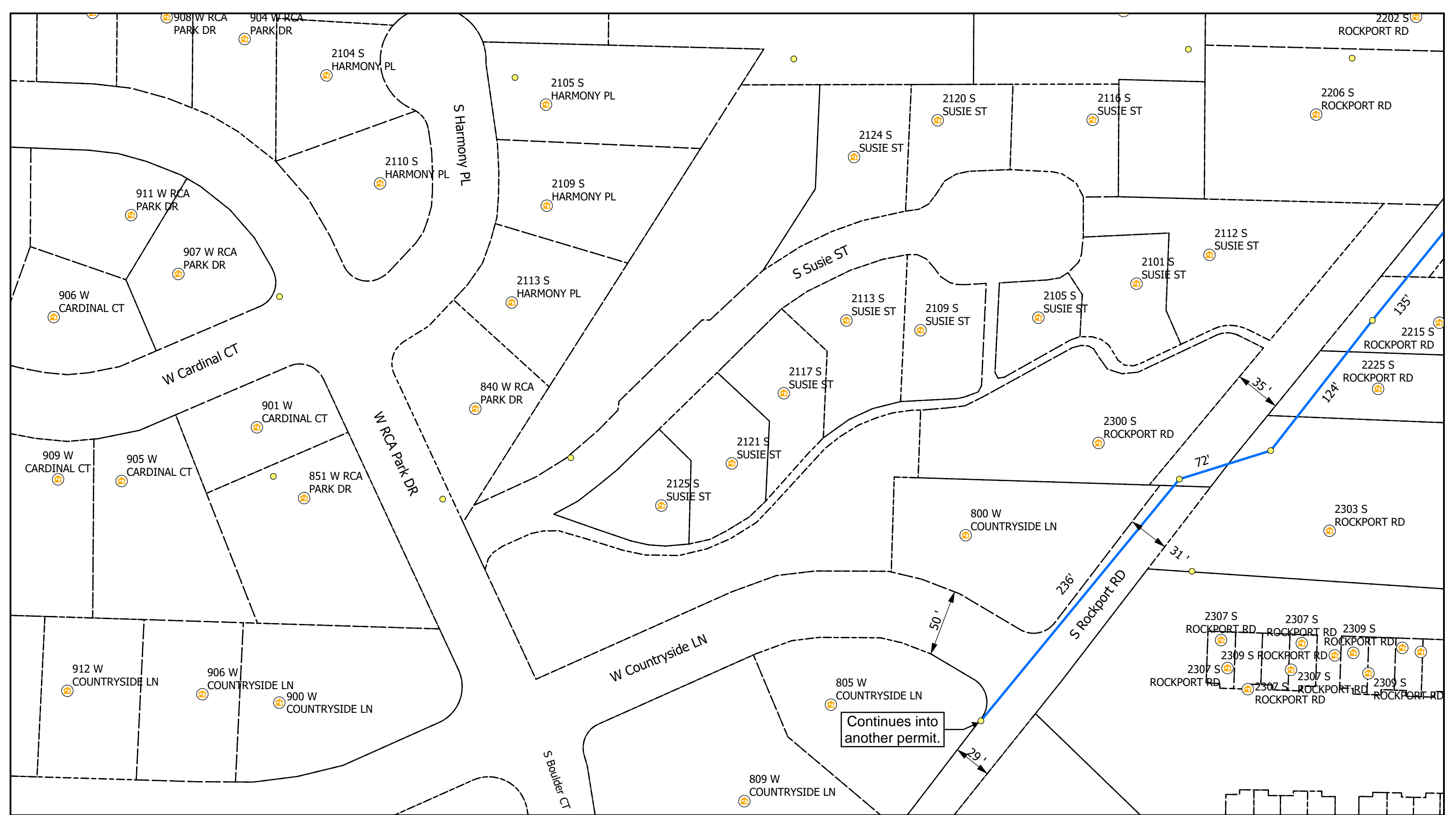

Legend

- Poles
- Ⓡ Risers
- Ⓜ Sidewalk
- V Vaults
- 🏠 Address
- Bloomington_Parcels
- Overhead Strand
- Y Anchor
- - - Conduit
- Grids

All Flowerpots 12" DIA



Continues into another permit.

City of Bloomington, IN Permit:
Design View

INI	BY	DATE	DESCRIPTION



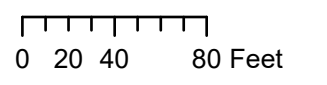
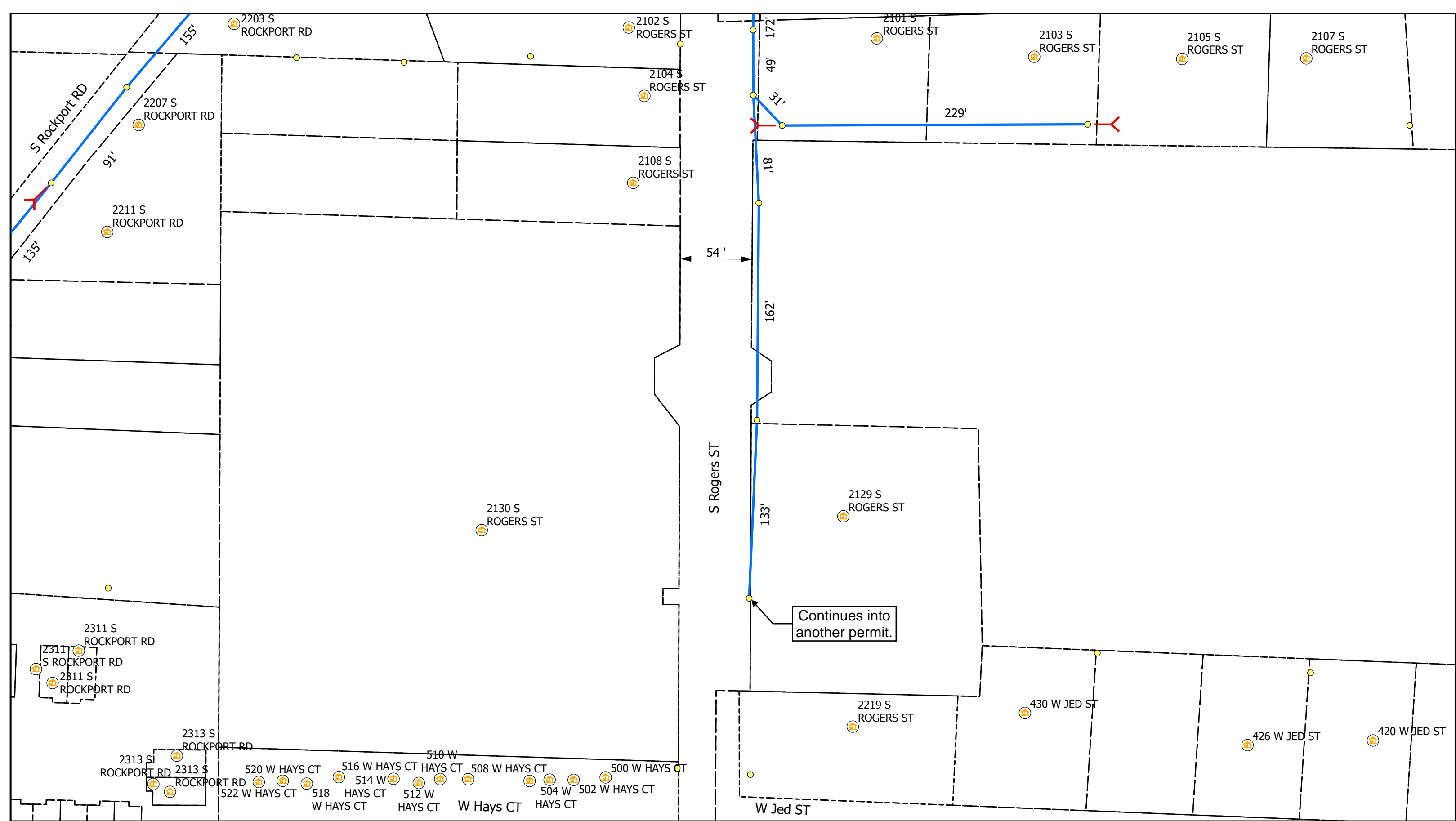

Legend

- Poles
- Ⓡ Risers
- ⏏ Sidewalk
- V Vaults
- 🏠 Address
- Bloomington_Parcels
- Overhead Strand
- Y Anchor
- - - Conduit
- Grids

All Flowerpots 12" DIA



City of Bloomington, IN Permit:
Design View

INI	BY	DATE	DESCRIPTION



Carlton® PV-Mold® Nonmetallic Pole Riser System

Carlton PV-Mold is a nonmetallic pole riser system designed to protect communications power cable installed on poles.

Features:

- Meets or exceeds requirements outlined in the National Electric Safety Code (NESC).
- Designed in accordance with NEMA TC-19 specifications.
- Ultraviolet, cold temperature and corrosive atmosphere resistant.
- Schedule 40 wall meets Schedule 80 PVC conduit impact requirements per NEMA TC-19.
- No grounding required.
- Belled end fits over each added section or conduit.
- Flame retardant.
- Requires no maintenance.
- PV-Mold acts as an insulator against electrical shock.
- Interchangeable parts and accessories to match the needs of specific requirements.



Steel U-Guard requires grounding strapping and does not have belled ends.



PV-Mold has belled ends, flanged design and does not require grounding.

Flanged Overall Length 10 Feet, Including Bell

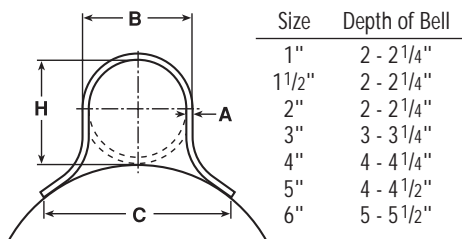

Slots are 1/2" from side to side, and allow for expansion and contraction.

Slot Dimensions: for sizes 2" through 6" are 5/16" wide, 3/4" long.

Slot Dimensions: for 1" and 1 1/2" are 3/16" wide, 3/4" long.

Slot Spacing: 18" from center, beginning 6" from end.

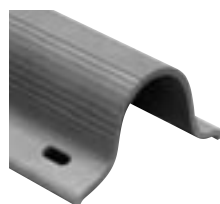

Standard Duty

Part No.	Size	Std. Ctn. Qty.	Std. Ctn. Wt. (lbs.)	Dimensions				Actual Impact @ 0°C 20 Pound Top
				A	B	C	H	
59208N	1"	294	1059	0.100"	1 5/8"	2 3/8"	1 5/8"	40 Ft.-Lbs.
59211N	2"	136	726	0.100"	2 3/8"	4 1/2"	2 3/8"	100 Ft.-Lbs.
59211X (5' length)	2"	136	363	0.100"	2 3/8"	4 1/2"	2 3/8"	100 Ft.-Lbs.
59213N	3"	66	761	0.150"	3 1/2"	6"	3 1/2"	110 Ft.-Lbs.
59213X (5' length)	3"	66	381	0.150"	3 1/2"	6"	3 1/2"	100 Ft.-Lbs.
59215N	4"	65	910	0.150"	4 1/2"	6 1/2"	4 1/2"	110 Ft.-Lbs.
59216N	5"	30	515	0.150"	5 1/2"	7 1/2"	5 1/2"	110 Ft.-Lbs.

Heavy Duty Schedule 40

59010N	1 1/2"	200	1142	0.145"	1 29/32"	3 1/2"	1 29/32"	100 Ft.-Lbs.
59011N	2"	136	1214	0.154"	2 3/8"	4 1/2"	2 3/8"	150 Ft.-Lbs.
59013N	3"	66	937	0.216"	3 1/2"	6"	3 9/32"	150 Ft.-Lbs.
59015N	4"	65	1621	0.237"	4 1/2"	6 1/2"	4 1/2"	260 Ft.-Lbs.
59015X (5' length)	4"	65	707	0.237"	4 1/2"	6 1/2"	4 1/2"	260 Ft.-Lbs.
59016N	5"	30	870	0.258"	5 1/2"	7 1/2"	5 1/2"	260 Ft.-Lbs.
59017N	6"	30	1160	0.280"	6 5/8"	8 3/4"	6 5/8"	260 Ft.-Lbs.

Extra Heavy Duty Schedule 80

59411N	2"	136	1549	0.218"	2 3/8"	4 1/2"	2 3/8"	300 Ft.-Lbs.
59413N	3"	66	1495	0.030"	3 1/2"	6"	3 1/2"	525 Ft.-Lbs.

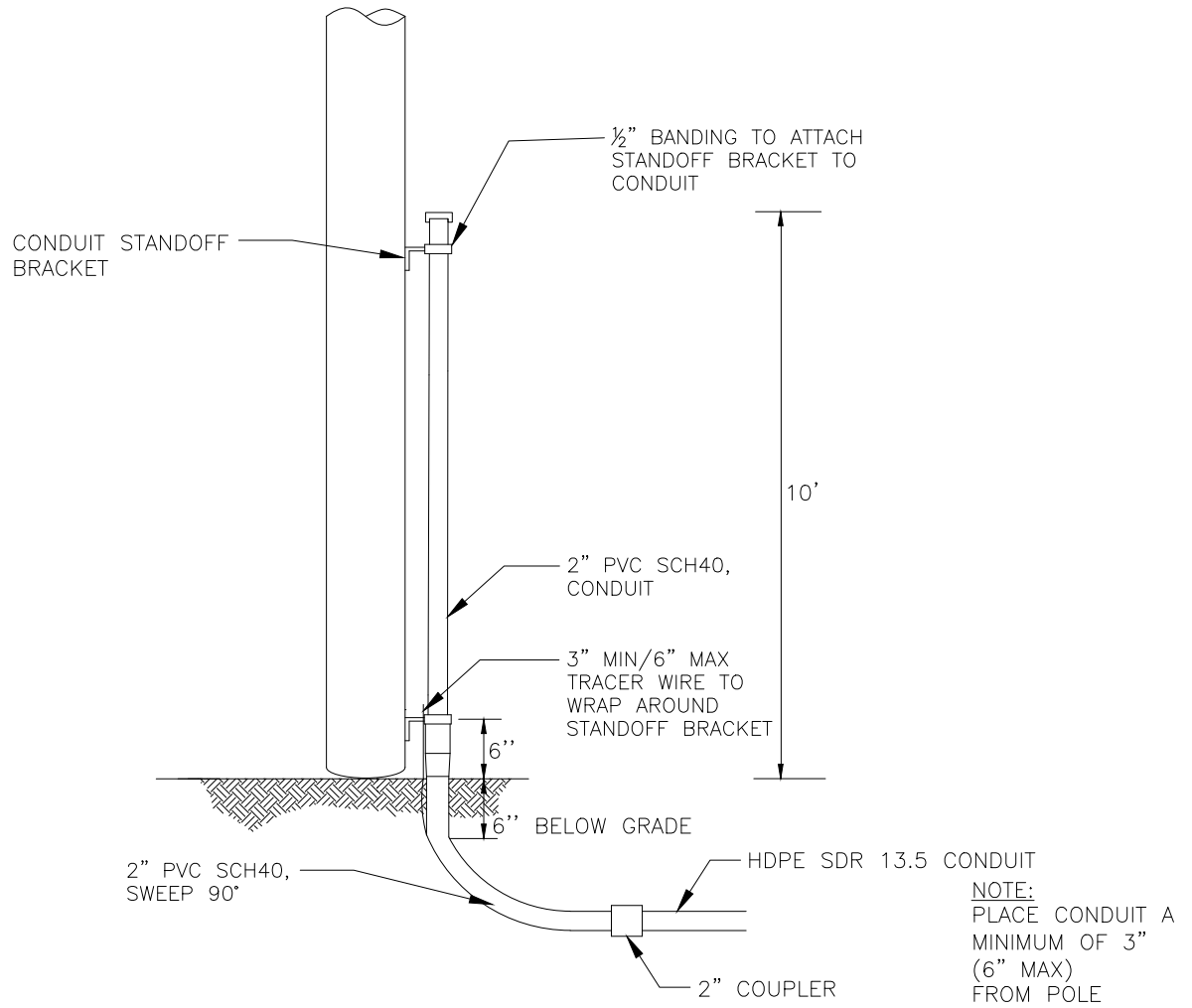

DESCRIPTION	QTY	MANUFACTURER (PREFERRED)	PART #
SCREW, LAG, 1/2" x 4-1/2"	10		
HDPE SDR 13.5 CONDUIT, VARIOUS SIZES	N/A		
2" PVC SCH40, RISER PIPE	1		
#12 TRACER WIRE	N/A		
2" PVC SCH40, SWEEP, 90 DEG	1		
CONDUIT STANDOFF BRACKET	VARIES		
CONDUIT STRAP KIT	VARIES		
2" COUPLER	1		



TYPICAL RISER
CONDUIT
WOOD POLE

(R2-W)

CONCEPTUAL SIDE VIEW

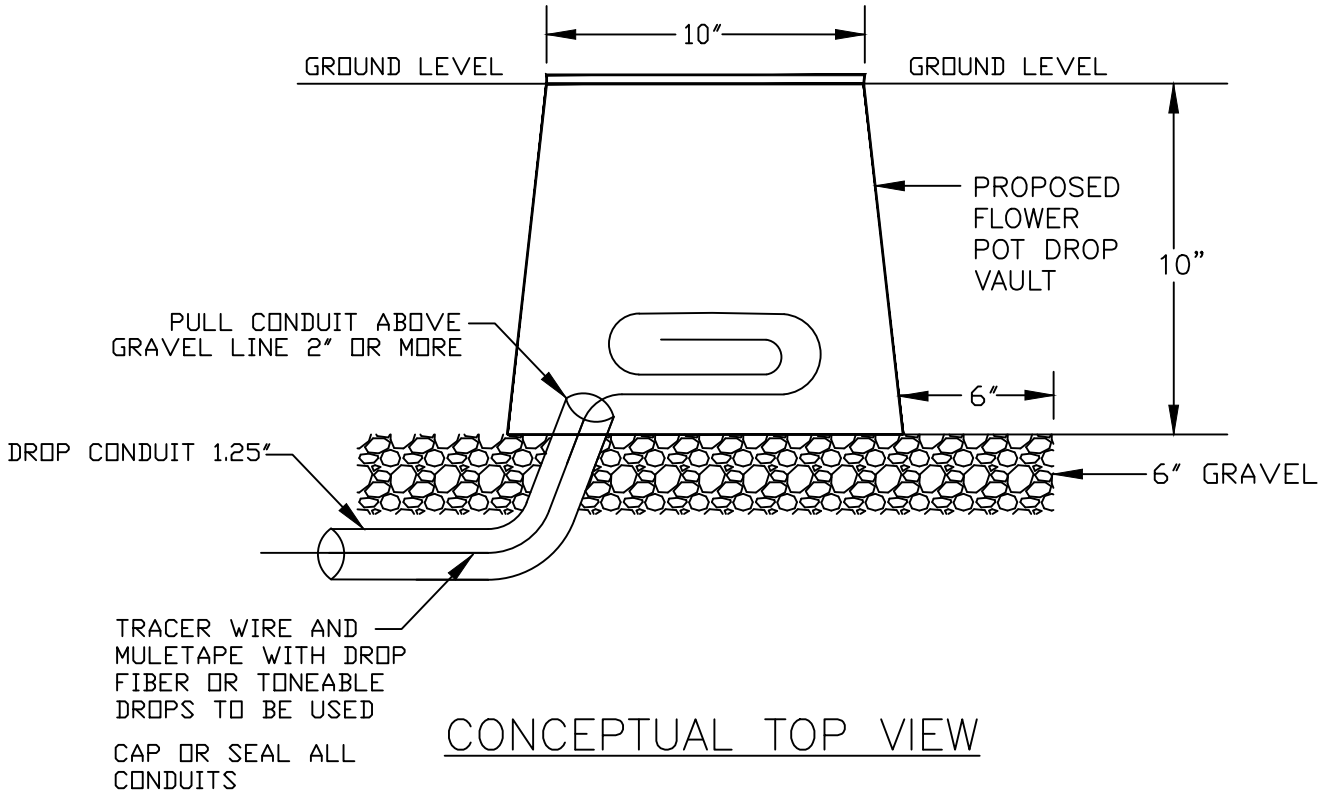

CONCEPTUAL TOP VIEW

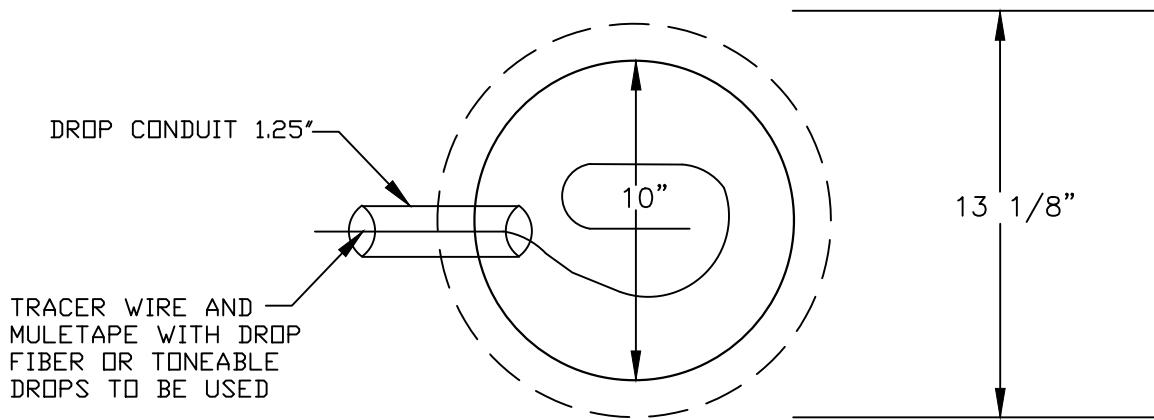

FLOWER POT

30"x48" PC UNIT, 2PC TIER 15/22
 18", 24", and 36" HEIGHT



AMERICAN POLYMER COMPANY

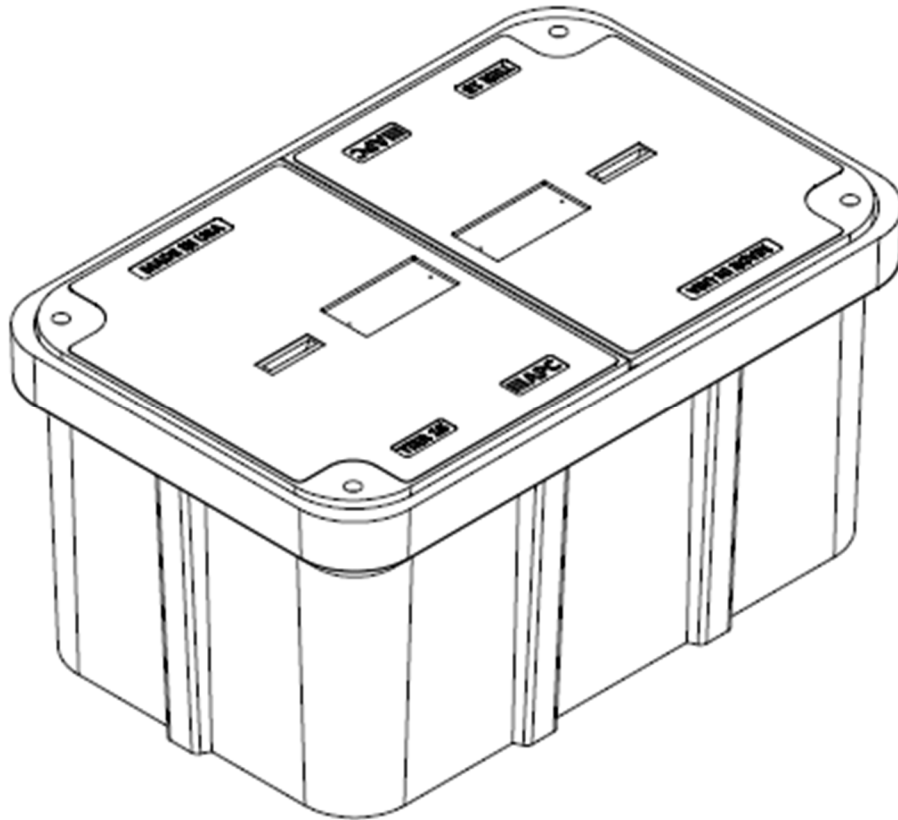

Description	Nominal Size	ANSI Tier	Part Number	Estimated Weight
PC Unit – TIER 15	30"x48"x18"	Tier 15	P304818HU15...	460 lbs.
PC Unit – TIER 22	30"x48"x18"	Tier 22	P304818HU22...	525 lbs.
PC Unit – TIER 15	30"x48"x24"	Tier 15	P304824HU15...	510 lbs.
PC Unit – TIER 22	30"x48"x24"	Tier 22	P304824HU22...	575 lbs.
PC Unit – TIER 15	30"x48"x36"	Tier 15	P304836HU15...	615 lbs.
PC Unit – TIER 22	30"x48"x36"	Tier 22	P304836HU22...	680 lbs.



30"x48" PC UNIT, 2PC TIER 15/22

18", 24", and 36" HEIGHT



AMERICAN POLYMER COMPANY

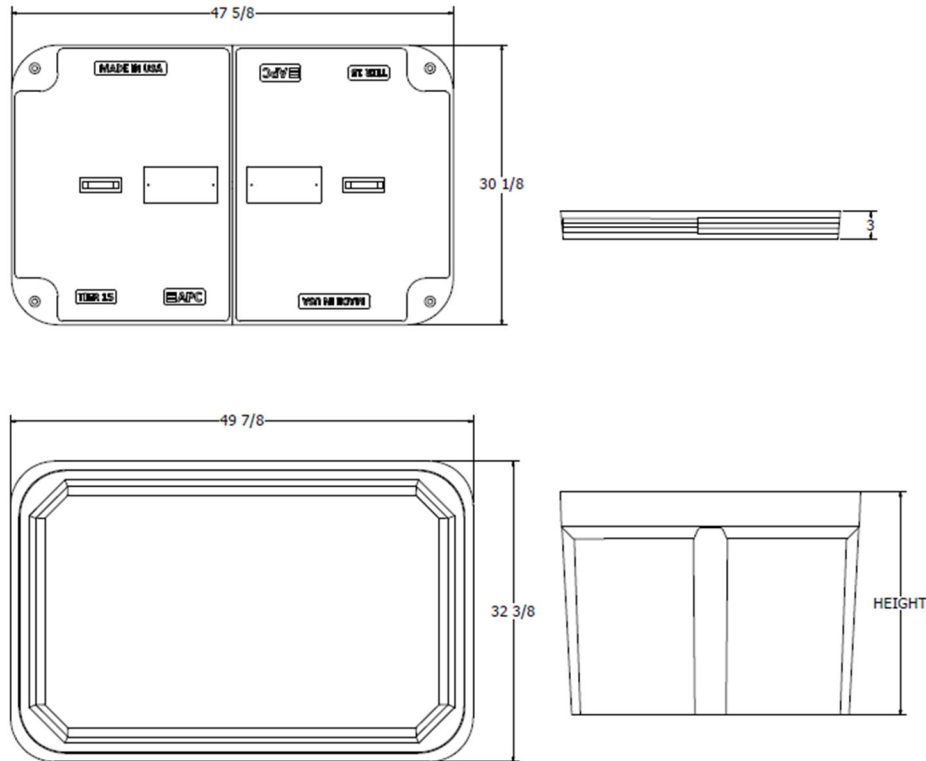

Components	Nominal Size	ANSI Tier	Part Number	Estimated Weight
Replacement Box	30"x48"x18"	Tier 22	P304818B22	185 lbs.
Replacement Box	30"x48"x24"	Tier 22	P304824B22	235 lbs.
Replacement Box	30"x48"x36"	Tier 22	P304836B22	340 lbs.
Replacement Lids - T15	30"x48" (half)	Tier 15	Various	150 lbs.
Replacement Lids - T22	30"x48" (half)	Tier 22	Various	170 lbs.

Bolt options



Machine Thread



Auger Thread



24"x36" PC UNIT, TIER 15/22
 18", 24", 30", and 36" HEIGHT



AMERICAN POLYMER COMPANY

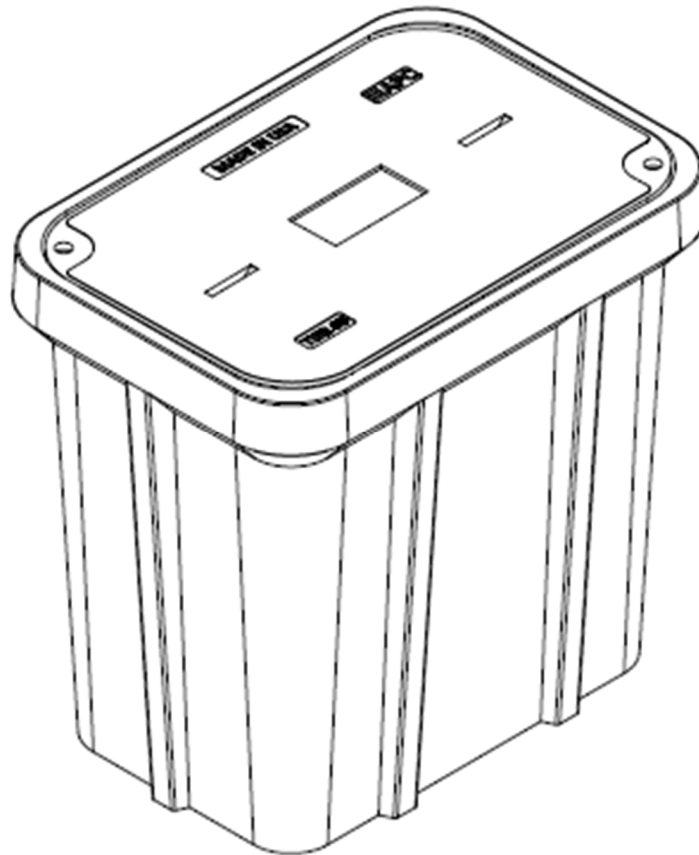

Description	Nominal Size	ANSI Tier	Part Number	Estimated Weight
PC Unit – TIER 15	24x36"x18"	Tier 15	P243618U15...	335 lbs.
PC Unit – TIER 22	24x36"x18"	Tier 22	P243618U22...	355 lbs.
PC Unit – TIER 15	24x36"x24"	Tier 15	P243624U15...	365 lbs.
PC Unit – TIER 22	24x36"x24"	Tier 22	P243624U22...	385 lbs.
PC Unit – TIER 15	24x36"x30"	Tier 15	P243630U15...	395 lbs.
PC Unit – TIER 22	24x36"x30"	Tier 22	P243630U22...	415 lbs.
PC Unit – TIER 15	24x36"x36"	Tier 15	P243636U15...	425 lbs.
PC Unit – TIER 22	24x36"x36"	Tier 22	P243636U22...	445 lbs.



24"x36" PC UNIT, TIER 15/22

18", 24", 30", and 36" HEIGHT



AMERICAN POLYMER COMPANY

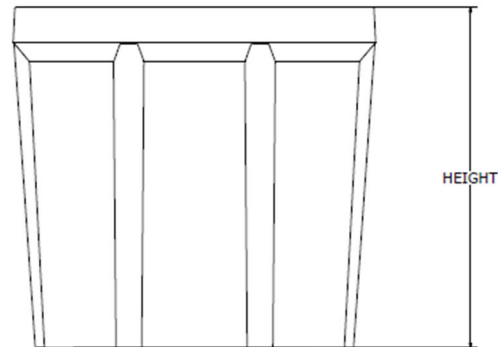
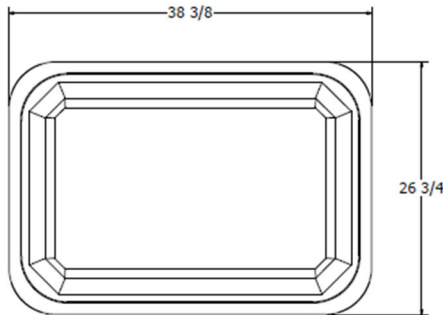
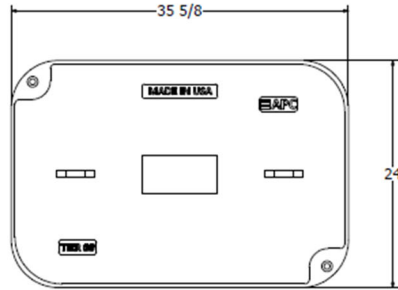

Components	Nominal Size	ANSI Tier	Part Number	Estimated Weight
Replacement Box	24"x36"x18"	Tier 22	P243618B22	165 lbs.
Replacement Box	24"x36"x24"	Tier 22	P243624B22	195 lbs.
Replacement Box	24"x36"x30"	Tier 22	P243630B22	225 lbs.
Replacement Box	24"x36"x36"	Tier 22	P243636B22	255 lbs.
Replacement Lids - T15	24"x36"	Tier 15	Various	170 lbs.
Replacement Lids - T22	24"x36"	Tier 22	Various	190 lbs.

Bolt options

Hex Head



Machine Thread



Penta Head



Auger Thread



17"x30" PC UNIT, TIER 15/22

12", 18", 24", and 30" HEIGHT



AMERICAN POLYMER COMPANY

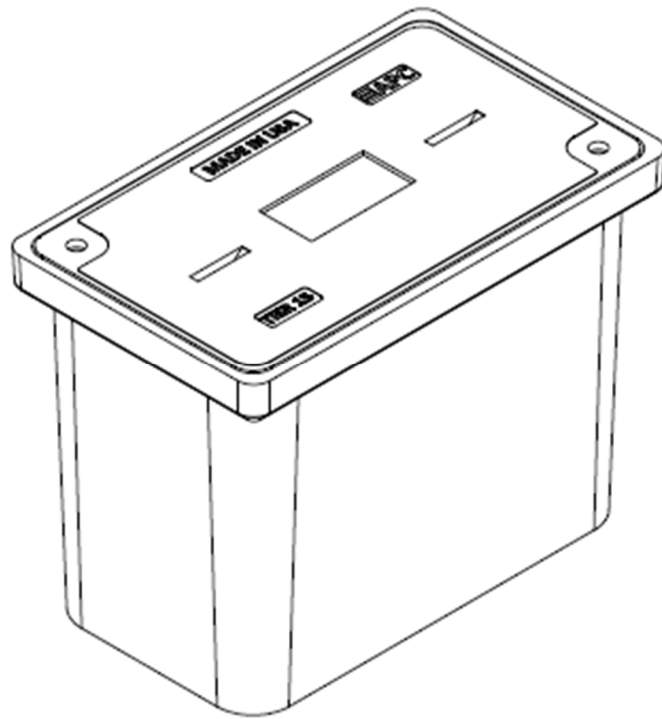

Description	Nominal Size	ANSI Tier	Part Number	Estimated Weight
PC Unit – TIER 15	17"x30"x12"	Tier 15	P173012U15...	138 lbs.
PC Unit – TIER 22	17"x30"x12"	Tier 22	P173012U22...	147 lbs.
PC Unit – TIER 15	17"x30"x18"	Tier 15	P173018U15...	172 lbs.
PC Unit – TIER 22	17"x30"x18"	Tier 22	P173018U22...	181 lbs.
PC Unit – TIER 15	17"x30"x24"	Tier 15	P173024U15...	192 lbs.
PC Unit – TIER 22	17"x30"x24"	Tier 22	P173024U22...	201 lbs.
PC Unit – TIER 15	17"x30"x30"	Tier 15	P173030U15...	217 lbs.
PC Unit – TIER 22	17"x30"x30"	Tier 22	P173030U22...	226 lbs.



17"x30" PC UNIT, TIER 15/22

12", 18", 24", and 30" HEIGHT



AMERICAN POLYMER COMPANY

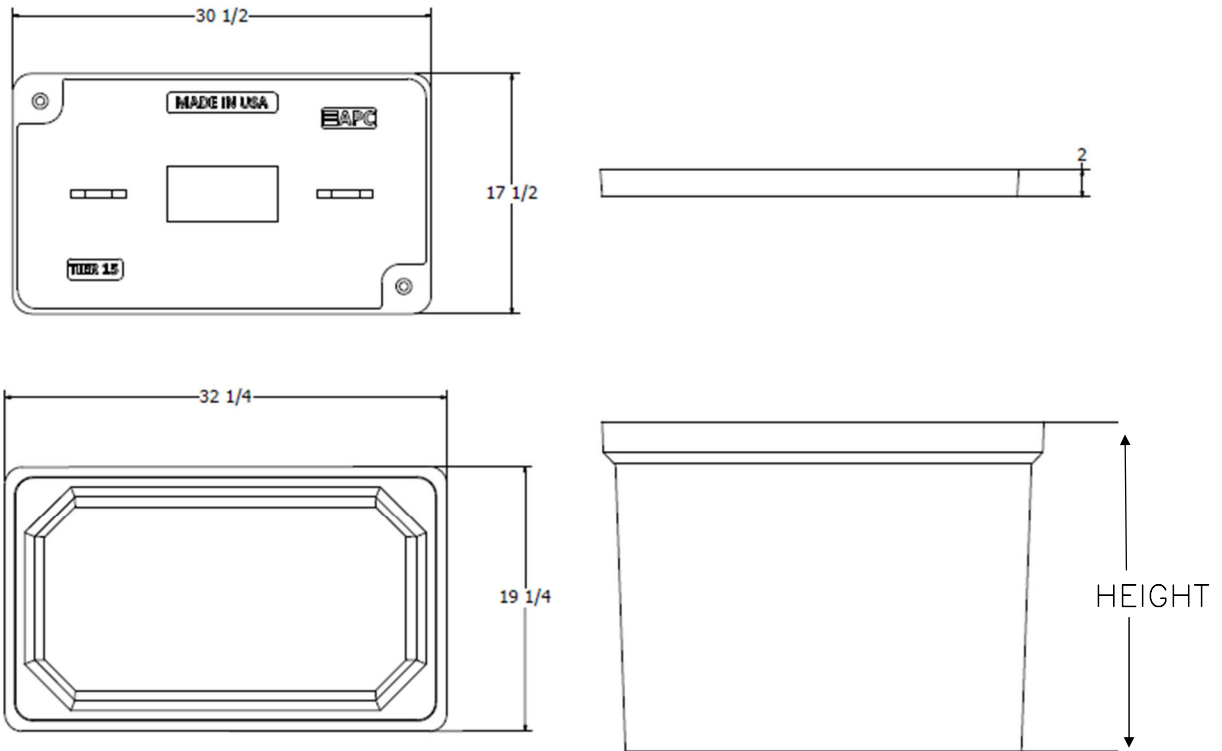

Components	Nominal Size	ANSI Tier	Part Number	Estimated Weight
Replacement Box	17"x30"X12"	Tier 22	P173012B22	66 lbs.
Replacement Box	17"x30"X18"	Tier 22	P173018B22	100 lbs.
Replacement Box	17"x30"X24"	Tier 22	P173024B22	120 lbs.
Replacement Box	17"x30"X30"	Tier 22	P173030B22	145 lbs.
Replacement Lids – T15	17"x30"	Tier 15	Various	72 lbs.
Replacement Lids – T22	17"x30"	Tier 22	Various	81 lbs.

Bolt options



Machine Thread



Auger Thread



33"x60" PC UNIT, 2PC TIER 15/22
36" HEIGHT



AMERICAN POLYMER COMPANY

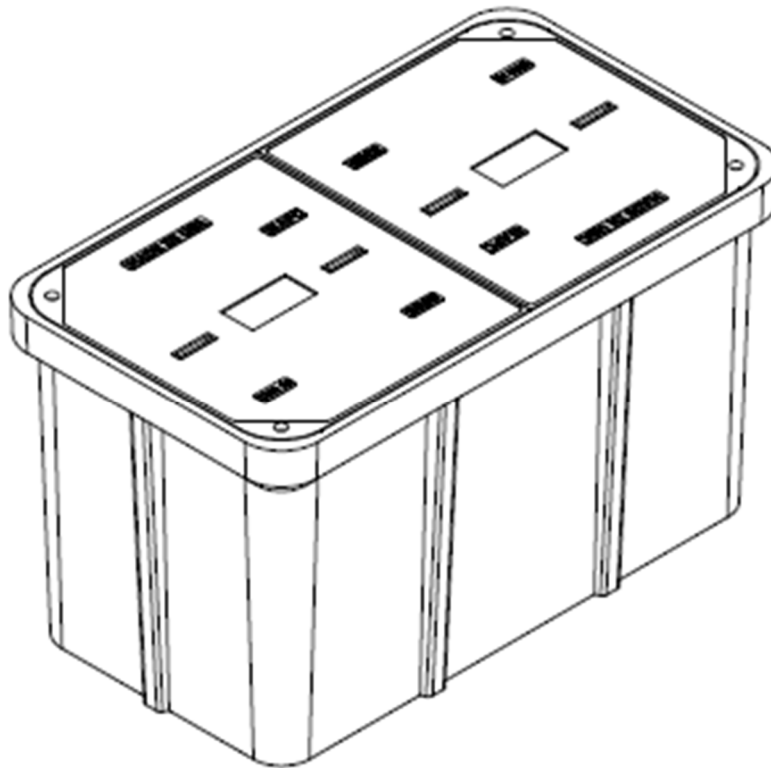

Description	Nominal Size	ANSI Tier	Part Number	Estimated Weight
PC Unit - TIER 15	33"x60"x36"	Tier 15	P336036U15...	930 lbs.
PC Unit - TIER 22	33"x60"x36"	Tier 22	P336036U22...	1030 lbs.



33"x60" PC UNIT, 2PC TIER 15/22

36" HEIGHT



AMERICAN POLYMER COMPANY

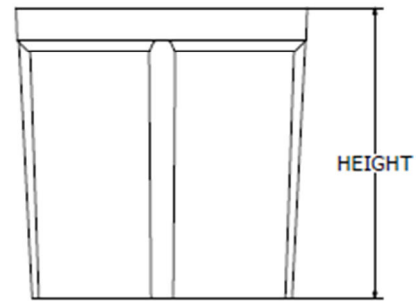
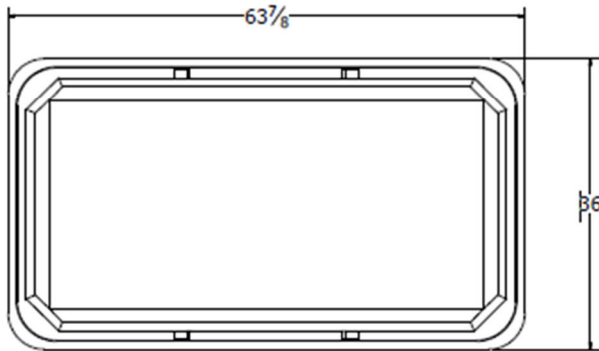
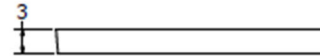
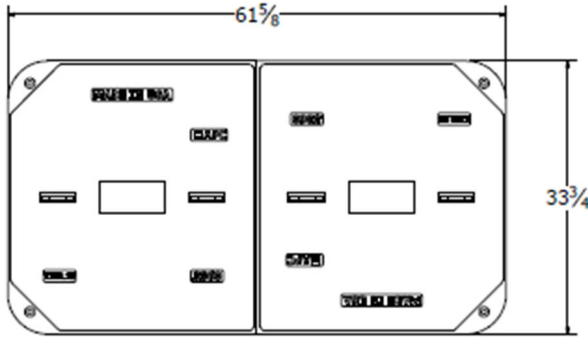

Components	Nominal Size	ANSI Tier	Part Number	Estimated Weight
Replacement Box	33"x60"x36"	Tier 22	P336036B22	530 lbs.
Replacement Lids - T15	33"x60" (half)	Tier 15	Various	200 lbs.
Replacement Lids - T22	33"x60" (half)	Tier 22	Various	250 lbs.

Bolt options

Hex Head



Machine Thread



Penta Head



Auger Thread



Spacing Charts Based on MUTCD		Must be Approved by an Engineer					
Speed (MPH) Prior To Road Work	SIGN SPACING, FT.		BUFFER SPACE, FT.	TAPER LENGTH, FT.	CHANNELIZING SPACING, FT.		
	Non-Divided Highways	Divided Highways	Length	Shoulder (10 ft. Width)	Lane (12 ft. Width)	Through Taper	Through Buffer/Work Area
0-35	200	200	250	70	245	35	50
40-45	350	500	360	150	540	40	80
50-55	500	1000	495	185	660	50	100
60-70	SA-1000, SB-1500, SC-2640		730	235	840	60	120
Urban Low Speed - 100 FT							

APPROVED/ACCEPTED BY:
ENGINEER, OWNER, or PRIME CONTRACTOR
 Check for Notice to Proceed.

Signature: _____

Company: _____



Date: 2/5/2024 Project: BLS01a-F07 S Strong St TCP1 :
Traffic Control Suggestion For: ATLANTIC ENGINEERING (AEG) :
By: Road Runner Safety Services, Inc. : Nathan

Comments:
Drawing not to scale. Traffic control plan must be approved by an engineer. This is a suggestion only. Road Runners Safety Services, Inc. has no liability for this suggested traffic control plan. Actual placement and spacing of all traffic control devices will depend on field conditions and must conform to MUTCD standards.

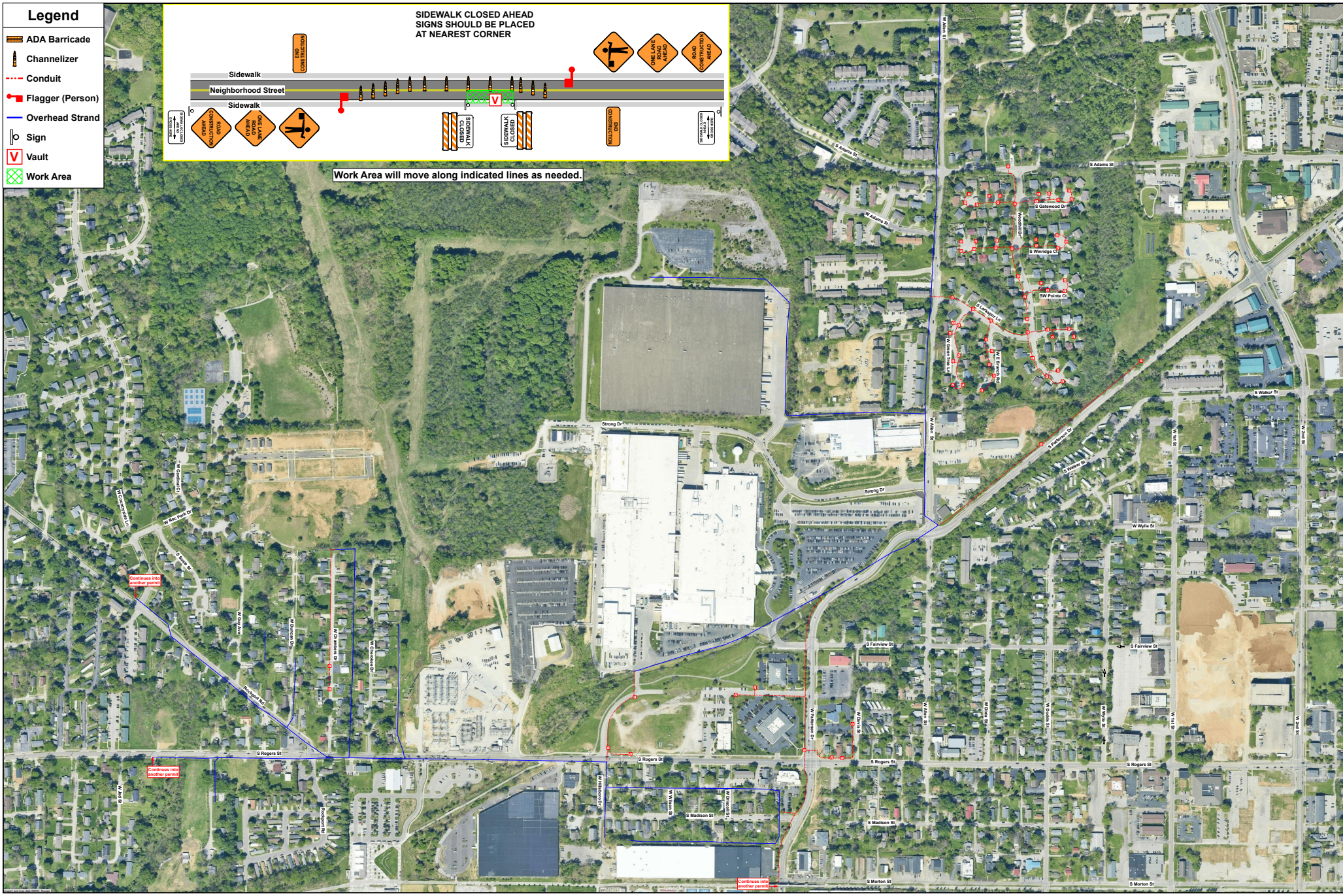



CITY OF BLOOMINGTON RIGHT-OF-WAY USE PERMIT APPLICATION

401 N Morton Street, Suite 130
P.O. Box 100
Bloomington, IN 47402

Phone: (812) 349-3913
Fax: (812) 349-3520
Email:
engineering@bloomington.in.gov

ROW EXCAVATION ROW USE

ADDRESS OF ROW ACTIVITY: BLS01a-F07_S Strong St

A. APPLICANT/AGENT INFORMATION:		D. TRAFFIC CONTROL DEVICES*:	
APPLICANT NAME: <u>Bret Simons</u>		<input checked="" type="checkbox"/> CONES <input type="checkbox"/> ARROWBOARD	
E-MAIL: <u>bret.simons@aeg.cc</u>		<input type="checkbox"/> LIGHTED BARRELS <input checked="" type="checkbox"/> TYPE 3 BARRICADES	
COMPANY: <u>Atlantic Engineering Group</u>		<input checked="" type="checkbox"/> FLAGGERS <input type="checkbox"/> BPD OFFICER	
ADDRESS: <u>P.O. Box 349</u>		*PROVIDING MUTCD COMPLIANT TEMPORARY TRAFFIC CONTROL DEVICES AND MAINTENANCE OF TRAFFIC (MOT) PLAN IS YOUR RESPONSIBILITY AND REQUIRED. See page 3 for additional MOT resources; the graph paper can be used for your MOT site plan if needed or you can submit a separate sheet	
CITY, STATE, ZIP: <u>Buford, GA 30515</u>			
24-HR EMERGENCY CONTACT NAME: <u>(706)654-2298</u>		E. METERED PARKING SPACES NEEDED: <input type="checkbox"/> Y <input type="checkbox"/> N	
24-HR CONTACT PHONE #: _____		IT IS THE RESPONSIBILITY OF THE APPLICANT TO RESERVE PARKING METER(S) APPLICATION LOCATED: https://bloomington.in.gov/transportation/parking/moving OR CONTACT PARKING SERVICES WITH QUESTIONS AT (812)349-3436	
INSURANCE #*: <u>TB5-691-473497-082</u> COMPANY: <u>ACORD</u>		F. IS THIS A <input type="checkbox"/> CBU* <input type="checkbox"/> COUNTY* <input type="checkbox"/> IU* <input type="checkbox"/> NP* PROJECT?	
BOND #*: <u>1160465</u> COMPANY: <u>LEXON</u>		PROJECT NAME: <u>BLS01a-F07_S Strong St</u>	
*INSURANCE & BOND MUST BE ON FILE WITH THE CITY BEFORE PERMIT WILL BE ISSUED		PROJECT #: <u>BLS01a-F07_S Strong St</u>	
SUBCONTRACTOR INFORMATION		PROJECT MGR.: <u>Patrick Brigman</u>	
(LIST ALL COMPANIES WORKING UNDER PRIMARY CONTRACTOR PERMIT)		PROJECT MGR. #: <u>215-847-8819</u>	
COMPANY NAME: _____		*CBU = CITY OF BLOOMINGTON UTILITIES *COUNTY = MONROE COUNTY	
B. WORK DESCRIPTION:		*IU = INDIANA UNIVERSITY *NP = NOT-FOR-PROFIT AGENCY	
<input type="checkbox"/> POD/DUMPSTER <input type="checkbox"/> CRANE <input type="checkbox"/> SCAFFOLDING <input checked="" type="checkbox"/> CONSTRUCTION USE*		G. EXCAVATIONS:	
(EXPLAIN): <u>Excavation</u>		SQ FT OF PAVEMENT* EXCAVATIONS: <u>N/A</u>	
*EXCAVATION, LONG TERM USE FOR STORAGE OF MATERIAL/EQUIPMENT/WALKAROUND		*PAVEMENT INCLUDES: IN OR UNDER CONCRETE, OR ASPHALT INCLUDING CURBS	
C. RIGHT OF WAY TO BE USED/CLOSED:		SQ FT OF NON-PAVEMENT* EXCAVATIONS: <u>206.78 Sq Ft</u>	
STREET NAME 1: <u>S Strong St</u>		*DIRT, GRASS, GRAVEL, LANDSCAPE AREA OR OTHER UNPAVED SURFACE	
1ST INTERSECTING STREET NAME: _____		LINEAL FT OF BORE*: <u>11,672 Lineal Ft</u>	
2ND INTERSECTING STREET NAME: _____		*BORE PITS SHALL BE CALCULATED AS SQ FT EXCAVATIONS	
<input type="checkbox"/> ROAD CLOSURE <input checked="" type="checkbox"/> LANE CLOSURE 1 <input checked="" type="checkbox"/> 2 <input type="checkbox"/> 3 <input type="checkbox"/>		# OF POLE INSTALLATIONS/REMOVAL: <u>N/A</u>	
<input checked="" type="checkbox"/> SIDEWALK* <input type="checkbox"/> BIKE LANE <input type="checkbox"/> OTHER		SQ FT OF SIDEWALK RECONSTRUCTION*: <u>N/A</u>	
TRANSIT STOP? <input type="checkbox"/> Y <input type="checkbox"/> N PARKING LANE(S)** <input type="checkbox"/> Y <input type="checkbox"/> N **NON-METERED		*CONCRETE OR ASPHALT SIDEWALK/PATH BEING IMPROVED/REPLACED	
START DATE: <u>Mar. 6th</u> END DATE: _____ # OF DAYS*: <u>30</u>		SQ FT OF SIDEWALK NEW CONSTRUCTION*: <u>N/A</u>	
STREET NAME 2: _____		*CONCRETE OR ASPHALT SIDEWALK/PATH THAT IS NEW INFRASTRUCTURE	
1ST INTERSECTING STREET NAME: _____		#RESIDENTIAL DRIVEWAY INSTALLATION: <u>N/A</u>	
2ND INTERSECTING STREET NAME: _____		 <p>TO SUBMIT A LOCATE REQUEST 24 HRS A DAY, 7 DAYS A WEEK CALL 811 OR 800-382-5544 CALL 2 WORKING DAYS BEFORE YOU DIG. IT'S THE LAW.</p>	
<input type="checkbox"/> ROAD CLOSURE <input type="checkbox"/> LANE CLOSURE 1 <input type="checkbox"/> 2 <input type="checkbox"/> 3 <input type="checkbox"/>			
<input type="checkbox"/> SIDEWALK* <input type="checkbox"/> BIKE LANE <input type="checkbox"/> OTHER		H. INDEMNIFICATION AGREEMENT:	
TRANSIT STOP? <input type="checkbox"/> Y <input type="checkbox"/> N PARKING LANE(S)** <input type="checkbox"/> Y <input type="checkbox"/> N **NON-METERED		The petitioner/applicant hereby agrees to hold harmless, defend and to indemnify the City of Bloomington from or against all claims, action, damages and expenses, including but not limited to reasonable attorney's fees or any alleged injury and/or death to any person or damage to any property arising, or alleged to have arisen out of any act of commission or omission on the part of the petitioner/applicant, his/her heirs, successors, or assigns regardless of whether such acts are the direct or indirect result of the public right-of-way use pursuant to this permit grant.	
START DATE: _____ END DATE: _____ # OF DAYS*: _____		I AFFIRM, UNDER THE PENALTIES FOR PERJURY, THAT THE FOREGOING REPRESENTATIONS ARE TRUE.	
*SIDEWALK CLOSURES FOR A PERIOD OR PERIODS TOTALING 24HRS OR MORE SHALL INSTALL A WALKAROUND UNLESS OTHERWISE APPROVED DURING REVIEW		PRINT NAME: <u>Bret Simons</u>	
STANDARD CLOSURE HOURS MON-FRI*: 9:00 AM - 3:00 PM & 6:00 PM - 9:00 PM		SIGNATURE: <u>Bret Simons</u>	
STANDARD CLOSURE HOURS <input checked="" type="checkbox"/> *NON-STANDARD CLOSURE HOURS <input type="checkbox"/>		DATE: <u>2/5/2024</u>	
REQUESTED CLOSURE HOURS: _____ AM - _____ PM			
*non-standard hours may not be allowed near schools, on arterials, or other circumstances and are subject to approval during the permitting process			
BMC 14.09.040 allows work from 6 AM to 10 PM without violating the noise ordinance (7AM to 9PM for pneumatic hammers)			

For Administration Use Only (applicable to CLOSURE approval)

Approved By: _____ BPW City Engineer Director Date: _____

Staff Representative: _____ Phone#: _____ Date: _____



Board of Public Works Staff Report

Project/Event: Permit Reinstatement for lane and sidewalk closures along The Stands, S Rogers St, S Rockport Rd, and W Country Club Dr

Staff Representative: Alex Gray

Petitioner/Representative: Lineal Contracting / Brian Busick

Date: February 13th, 2024

Report: Lineal Contracting is requesting the reinstatement of a previously approved permit request that was seen by the Board in July 2022. The request is for lane and sidewalk closures for underground and aerial fiber placement for AT&T in the neighborhoods of S Rogers St, S Rockport Rd, The Stands, and W Country Club Dr. Most of the work will be outside of the right-of-way, but short closures in the right-of-way are expected while work is occurring.

The timeline is expected to be shorter than the 90 days for The Stands neighborhood and 70 days for the S Rogers and W Country Club Dr areas. The timeline is still being discussed with the contractor, but will be confirmed prior to the Board meeting.

Note: All documents associated with the request are originally from 2022, including the original ROW permit that was issued.

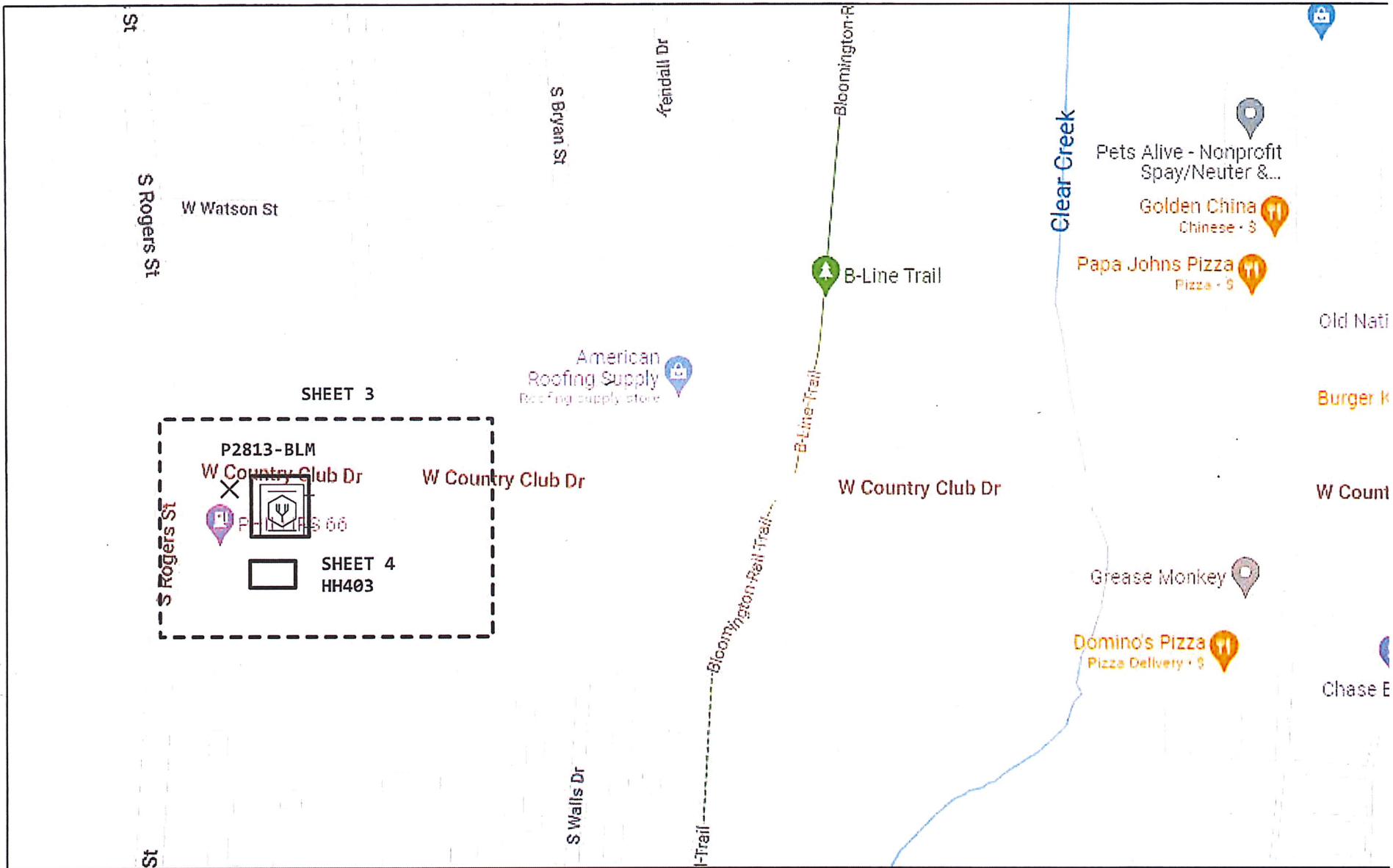

CONSTRUCTION NOTES

- 1 Think Safety - Work Safely
- 2 Coordinator: ANDREW MULLIS
- 3 KV - 301 TO 15KV
- 4 Run/Rope at minimum 24"

188

(1997) 822C 242'
3412LT-072

BL002, 73-74	NC	NC
<A00BV8X> BL001, 191-192	NC	NC
BL002, 77-78	NC	NC
<9505236> BL002, 13-14	NC	NC
<9505236> BL002, 15-18	NC	NC
BL002, 75-76	NC	NC
<A012E97> BL002, 99-102	NC	NC
(DD, 19-24)	<A025WFJ> BL002, 91-96	NC
(DD, 25-26)	NC	<A029ADZ> BL002, 103-104
DD, 27-48	NC	NC
BL001, 121-144	NC	NC

PUSHING FIBERS

SEE SHEET 3
TO P2813-BLM

188
PUSHING FIBERS

P814-4418

TO FIELD

MGNV

822C

1 SPlice FIBER

186

100

100

100

100

193

W COUNTRY CLUB DR

E WINSLOW RD

S WALNUT ST

187

(2007) 822C
5BQ2MT-072

BL001, 121-144	NC	PREV UT
BL002, 13-18	NC	
BL001, 191-192	NC	
(M, 33-38)	<A025WFJ> BL002, 91-96	
BL001, 159-168	NC	
43, 37-40	NC	
43, 35-36	NC	
DD, 7-8	NC	
43, 29-34	NC	
BL002, 99-108	NC	

140

(2005) 822C 110'
5BQ2MT-024
<A012E97> C, 1-4
<A00HNSM> C, 5-6
DF, 7-24

193

(2007) 822C 730'
5BQ2MT-072
DF, 1-4
DD, 5-6
DF, 7-14
<A012E97> R, 15-18
BL002, 103-108
DF, 25-32
BL001, 153-160
DF, 41-44
<A00HNSM> BL001, 165-166
BL001, 167-168
DF, 49-64
<9505236> E, 65-70
DF, 71-72

141

(2
5B
A,
BL
<
A,

186

PLACE 864 RETROFIT PFP INSIDE 403 COUNTY CLUB DR XBOX
 PLACE NEW 4"-PVC FROM HH TO XBOX
 PLACE NEW 4"-PVC FROM HH TO P814-4426-BLM

845C
 7
 4 SPLICE FIBER EXISTING RIB

4C
 13
 1 MW CWA ONLY INSPECTOR

85C
 6
 1 PLACE AND CLEAT RISER CAB

85C
 12
 1 MW CWA ONLY INSPECTOR

ROW

ROW

EOP/FOS

W COUNTRY CLUB DR

EOP/FOS

161
 TO FIELD

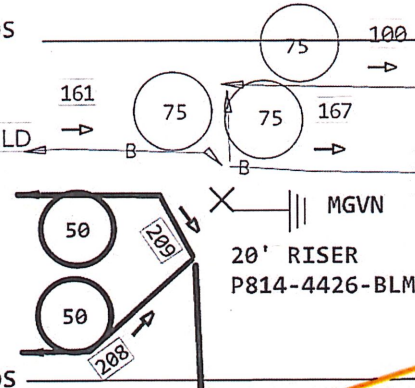

PUSHING FIBERS

SEE SHEET 4 TO HH403
 SEE SHEET 2 FROM P814-4418

BORE TRUCK PARKED FOR BORES. AERIAL TRUCK PARKED FOR AERIAL WORK. SIGNS IN PLACE FOR TRAFFIC CONTROL.

85C
 1
 ATT. 200002651
 BJFNA864-100ST
 1 MATERIAL ONLY
 1 SVA ONLY - PLACE PEDESTAL

207
 BLTNIN01PFP
 F 403-4 COUNTRY CLUB DR XB
 BJFNA864-100ST (PPA) 85C
 IN SPT3188PA,1-64
 OUT PON403CC,1-864

206
 PYTPINJ0023
 F 403-4 COUNTRY CLUB DR XB
 SPLAPC1X64CMD (PPA) 85C
 IN BL002,103-103
 85C 1X64 SPT3188PA,1-64

2
 85C
 CONT-PL-CABLE
 100 EXEMPT MATERIAL ONLY
 100 SVA ONLY - PLACE ITEM IN

209 (PPA) 85C 100'
 INV
 PFP STUB CA
 PON403CC,433-864

3
 85C
 CONT-PL-CABLE
 100 EXEMPT MATERIAL ONLY
 100 SVA ONLY - PLACE ITEM IN

208 (PPA) 85C 100'
 INV
 PFP STUB CA
 PON403CC,1-432

11
 85C
 3 TERMINATE

ORDER AND PLACE
 (1) 1X64 SPLITTER
 ATT.200004838

8
 85C
 SPLAPC1X64CMD
 1 PLACE MATERIAL ONLY PER E
 1 NO LABOR ASSOCIATED WITH

10
 85C
 @ PFP/SPT TO CO
 64 TESTING FIBER FACILITIES

9
 85C
 @ CO TO PFP/SPT
 64 TESTING FIBER FACILITIES

202 NEW 4"-PVC
 P-XB=70'

P2893

FENCE

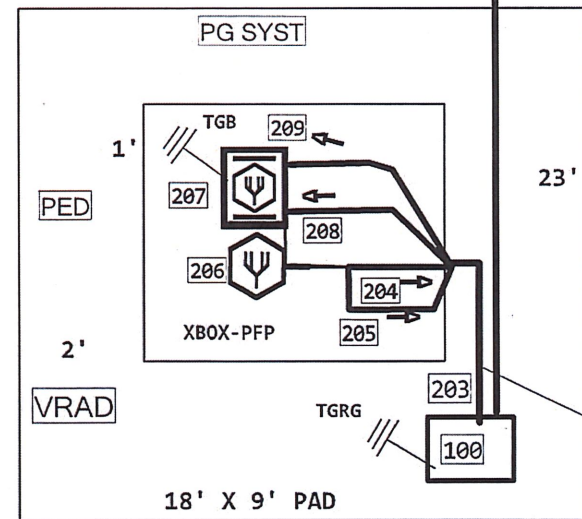

204 (PPA) 85C 0'

205 (PPA) 85C 0'

DRIVEWAY

NE
 HH

W COUNTRY CLUB DR

S ROGERS ST

NEW 4" - PVC
HH - XB = 5'

203

SEE SHEET 3
FROM PFP

SEE SHEET 3
FROM P814-4426-BLM

SEE SHEET 3
TO P814-4426-BLM

SEE SHEET 3
TO P814-4426-BLM

SEE SHEET 2
FRPM P814-4418

TO CO

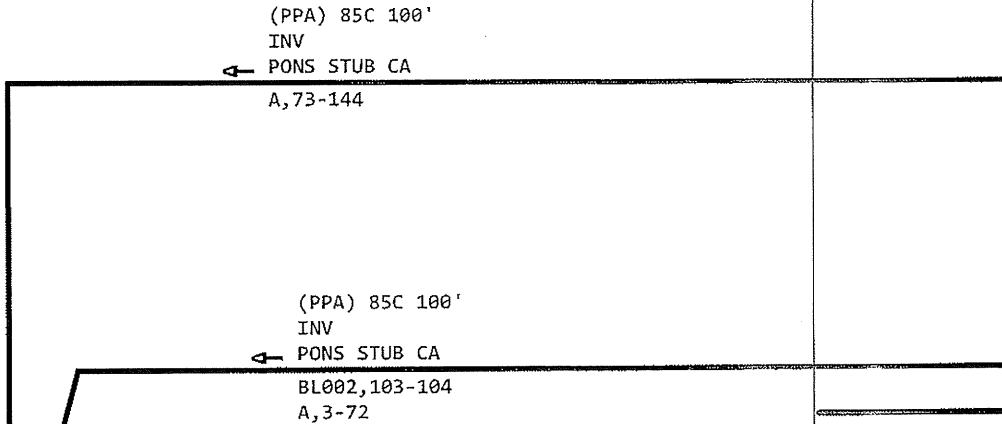
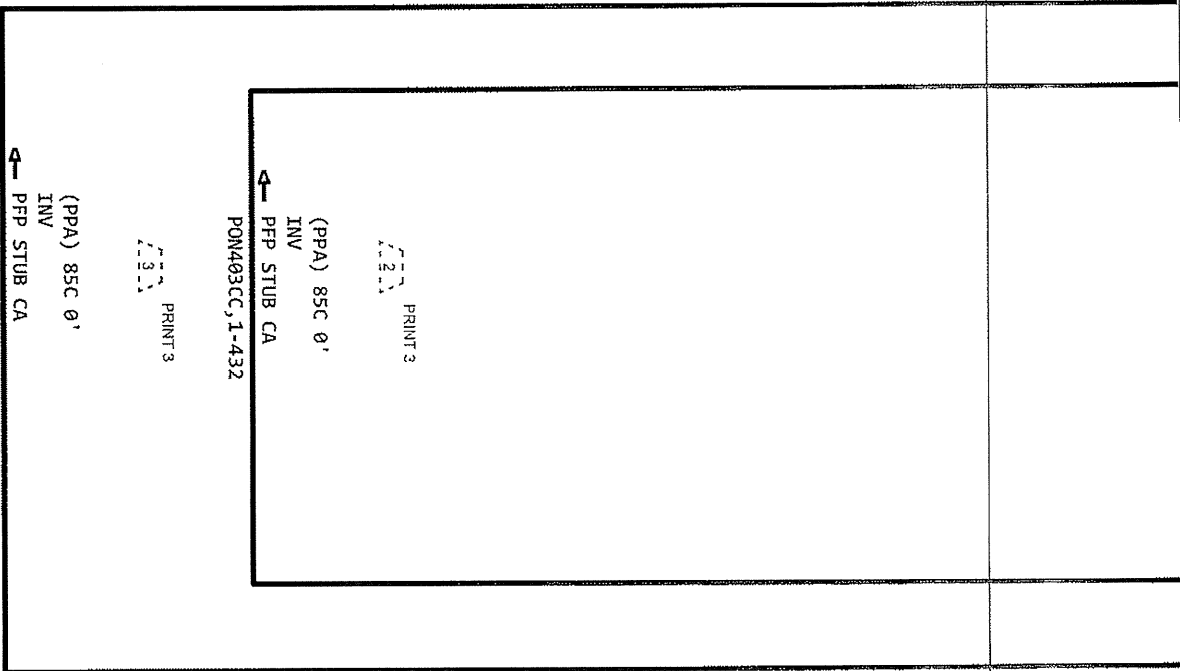

- 1 85C CONT-PL-CABLE 100 EXEMPT MATERIAL ONLY 100 SYA ONLY - PLACE ITEM IN
- 2 85C CONT-PL-CABLE 100 EXEMPT MATERIAL ONLY 100 SYA ONLY - PLACE ITEM IN

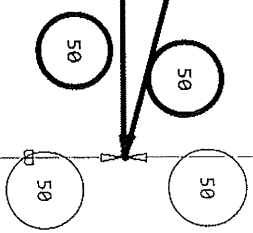

(2008) 845C 0' 5BQ2MT-024
BL001, 121-122 NC
<A00EC82> D, 3-4 NC
C, 5-12 NC
(C, 13-14) <A029ADZ> BL002, 103-104

REMOVE BT

ROW

RC

EOP/FOS

W COUNTRY CLUB DR

75'

35'

W COUNTRY CLUB DR

EOP/FOS

20' RISER
P814-4426-BLM

4" SIDEWALK

BOS ROW

NEW 4"-PVC
P-XB=70'

80'

PNT

2'

S ROGERS ST

FENCE

P2893

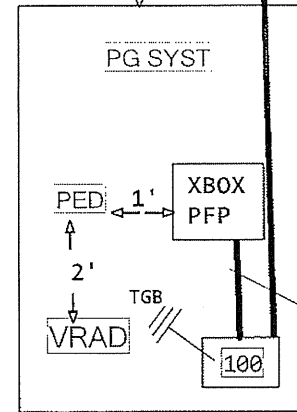

18' X 9' PAD

NEW 4"-PVC
HH-XB=5'

DRIVEWAY

23'



CITY OF BLOOMINGTON

RIGHT-OF-WAY USE PERMIT APPLICATION

RECEIVED

6/3/22

101 N. Morton Street, Suite 130
 P.O. Box 100
 Bloomington, IN 47402
 Phone: (812) 349-3913
 Fax: (812) 349-3520
 Email:
 engineering@bloomington.in.gov

ROW EXCAVATION ROW USE
 ADDRESS OF ROW ACTIVITY: _____

<p>A. APPLICANT/AGENT INFORMATION:</p> <p>APPLICANT NAME: <u>BRIAN BUSICK</u></p> <p>E-MAIL: <u>bbusick@linealcontracting.com</u></p> <p>COMPANY: <u>LINEAL CONTRACTING INC.</u></p> <p>ADDRESS: <u>2922 MITCHELL ROAD</u></p> <p>CITY, STATE, ZIP: <u>BEDFORD IN. 47421</u></p> <p>24-HR EMERGENCY CONTACT NAME: <u>BRIAN BUSICK</u></p> <p>24-HR CONTACT PHONE #: <u>812 - 521 - 3474</u></p> <p>INSURANCE #*: <u>5000142821</u> COMPANY: <u>THOMBURG</u></p> <p>BOND #: <u>69390442</u> COMPANY: <u>WESTERN SURETY</u></p> <p><small>* INSURANCE & BOND MUST BE ON FILE WITH THE CITY BEFORE PERMIT WILL BE ISSUED</small></p> <p style="text-align: center;">**SUBCONTRACTOR INFORMATION**</p> <p>(LIST ALL COMPANIES WORKING UNDER PRIMARY CONTRACTOR PERMIT)</p> <p>COMPANY NAME: _____</p>	<p>D. TRAFFIC CONTROL DEVICES*:</p> <p><input checked="" type="checkbox"/> CONES <input type="checkbox"/> ARROWBOARD</p> <p><input type="checkbox"/> LIGHTED BARRELS <input type="checkbox"/> TYPE 3 BARRICADES</p> <p><input checked="" type="checkbox"/> FLAGGERS <input type="checkbox"/> BPD OFFICER</p> <p><small>*PROVIDING MUTCD COMPLIANT TEMPORARY TRAFFIC CONTROL DEVICES AND MAINTENANCE OF TRAFFIC (NOT) PLAN IS YOUR RESPONSIBILITY AND REQUIRED See page 3 for additional MOT resources; the graph paper can be used for your MOT site plan if needed or you can submit a separate sheet</small></p>
<p>B. WORK DESCRIPTION:</p> <p><input type="checkbox"/> POD/DUMPSTER <input type="checkbox"/> CRANE <input type="checkbox"/> SCAFFOLDING <input type="checkbox"/> CONSTRUCTION USE*</p> <p>(EXPLAIN): <u>UNDERGROUND FIBER PLACEMENT , AERIAL</u></p> <p><small>*EXCAVATION, LONG TERM USE FOR STORAGE OF MATERIAL/EQUIPMENT/WALKAROUND</small></p>	<p>E. METERED PARKING SPACES NEEDED: <input type="checkbox"/> Y <input checked="" type="checkbox"/> N</p> <p><small>IT IS THE RESPONSIBILITY OF THE APPLICANT TO RESERVE PARKING METER(S) APPLICATION LOCATED: https://bloomington.in.gov/transportation/parking/moving OR CONTACT PARKING SERVICES WITH QUESTIONS AT (812)349-3436</small></p>
<p>C. RIGHT OF WAY TO BE USED/CLOSED:</p> <p>STREET NAME 1: <u>3034 S. ROGERS ST.</u></p> <p>1ST INTERSECTING STREET NAME: _____</p> <p>2ND INTERSECTING STREET NAME: _____</p> <p><input type="checkbox"/> ROAD CLOSURE <input type="checkbox"/> LANE CLOSURE 1 <input type="checkbox"/> 2 <input type="checkbox"/> 3 <input type="checkbox"/></p> <p><input type="checkbox"/> SIDEWALK* <input type="checkbox"/> BIKE LANE <input type="checkbox"/> OTHER</p> <p>TRANSIT STOP? <input type="checkbox"/> Y <input type="checkbox"/> N PARKING LANE(S)** <input type="checkbox"/> Y <input type="checkbox"/> N <small>**NON-METALLED</small></p> <p>START DATE: _____ END DATE: _____ # OF DAYS*: <u>15</u></p> <p>STREET NAME 2: _____</p> <p>1ST INTERSECTING STREET NAME: _____</p> <p>2ND INTERSECTING STREET NAME: _____</p> <p><input type="checkbox"/> ROAD CLOSURE <input type="checkbox"/> LANE CLOSURE 1 <input type="checkbox"/> 2 <input type="checkbox"/> 3 <input type="checkbox"/></p> <p><input type="checkbox"/> SIDEWALK* <input type="checkbox"/> BIKE LANE <input type="checkbox"/> OTHER</p> <p>TRANSIT STOP? <input type="checkbox"/> Y <input type="checkbox"/> N PARKING LANE(S)** <input type="checkbox"/> Y <input type="checkbox"/> N <small>**NON-METALLED</small></p> <p>START DATE: _____ END DATE: _____ # OF DAYS*:</p> <p><small>*SIDEWALK CLOSURES FOR A PERIOD OR PERIODS TOTALING 24 HRS OR MORE SHALL INSTALL A WALKAROUND UNLESS OTHERWISE APPROVED DURING REVIEW</small></p>	<p>F. IS THIS A <input type="checkbox"/> CBU* <input type="checkbox"/> COUNTY* <input type="checkbox"/> IU* <input type="checkbox"/> NP* PROJECT?</p> <p>PROJECT NAME: <u>3034 S. ROGERS ST.</u></p> <p>PROJECT #: <u>A029AE2</u></p> <p>PROJECT MGR.: <u>ZACHARY A. DECKARD</u></p> <p>PROJECT MGR. #: <u>812 - 521 - 3474</u></p> <p><small>*CBU = CITY OF BLOOMINGTON UTILITIES *COUNTY = MONROE COUNTY *IU = INDIANA UNIVERSITY *NP = NOT-FOR-PROFIT AGENCY</small></p>
<p>G. EXCAVATIONS:</p> <p>SQ FT OF PAVEMENT* EXCAVATIONS: _____</p> <p><small>*PAVEMENT INCLUDES: IN OR UNDER CONCRETE, OR ASPHALT INCLUDING CURBS</small></p> <p>SQ FT OF NON-PAVEMENT* EXCAVATIONS: <u>2</u></p> <p><small>*DIRT, GRASS, GRAVEL, LANDSCAPE AREA OR OTHER UNPAVED SURFACE</small></p> <p>LINEAL FT OF BORE*: <u>50'</u></p> <p><small>*BORE PITS SHALL BE CALCULATED AS SQ FT EXCAVATIONS</small></p> <p># OF POLE INSTALLATIONS/REMOVAL: _____</p> <p>SQ FT OF SIDEWALK RECONSTRUCTION*: _____</p> <p><small>*CONCRETE OR ASPHALT SIDEWALK/PATH BEING IMPROVED/REPLACED</small></p> <p>SQ FT OF SIDEWALK NEW CONSTRUCTION*: _____</p> <p><small>*CONCRETE OR ASPHALT SIDEWALK/PATH THAT IS NEW INFRASTRUCTURE</small></p> <p># RESIDENTIAL DRIVEWAY INSTALLATION: _____</p>	<p>H. INDEMNIFICATION AGREEMENT:</p> <p><small>The petitioner/applicant hereby agrees to hold harmless, defend and to indemnify the City of Bloomington from or against all claims, action, damages and expenses, including but not limited to reasonable attorney's fees or any alleged injury and/or death to any person or damage to any property arising or alleged to have arisen out of any act of commission or omission on the part of the petitioner/applicant, his/her heirs, successors, or assigns regardless of whether such acts are the direct or indirect result of the public right-of-way use pursuant to this permit grant.</small></p> <p>I AFFIRM, UNDER THE PENALTIES FOR PERJURY, THAT THE FOREGOING REPRESENTATIONS ARE TRUE.</p> <p>PRINT NAME: <u>BRIAN BUSICK</u></p> <p>SIGNATURE: </p> <p>DATE: <u>6/2/2022</u></p>



TO SUBMIT A LOCATE REQUEST 24 HRS A DAY,
 7 DAYS A WEEK
 CALL 811 OR 800-382-5544
 CALL 2 WORKING DAYS BEFORE YOU DIG.
 IT'S THE LAW.

For Administration Use Only (applicable to CLOSURE approval)

Approved By: _____ BPW City Engineer Director Date: _____

Staff Representative: _____ Phone#: _____ Date: _____



**CITY OF BLOOMINGTON
RIGHT-OF-WAY USE PERMIT APPLICATION**

RECEIVED
6/3/22

401 N. Morton Street, Suite 130
P.O. Box 100
Bloomington, IN 47402
Phone: (812) 349-3913
Fax: (812) 349-3520
Email:
engineering@bloomington.in.gov

ROW EXCAVATION ROW USE
ADDRESS OF ROW ACTIVITY: _____

<p>A. APPLICANT/AGENT INFORMATION:</p> <p>APPLICANT NAME: <u>LINEAL CONTRACTING INC.</u></p> <p>E-MAIL: <u>bbusick@linealcontracting.com</u></p> <p>COMPANY: <u>LINEAL CONTRACTING INC.</u></p> <p>ADDRESS: <u>2922 MITCHELL ROAD</u></p> <p>CITY, STATE, ZIP: <u>BEDFORD IN. 47421</u></p> <p>24-HR EMERGENCY CONTACT NAME: <u>BRIAN BUSICK</u></p> <p>24-HR CONTACT PHONE #: <u>812 - 521 - 3474</u></p> <p>INSURANCE #*: <u>5000142821</u> COMPANY: <u>THOMBURG</u></p> <p>BOND #*: <u>69390442</u> COMPANY: <u>WESTERN SURETY</u></p> <p><small>* INSURANCE & BOND MUST BE ON FILE WITH THE CITY BEFORE PERMIT WILL BE ISSUED</small></p> <p align="center">**SUBCONTRACTOR INFORMATION**</p> <p><small>(LIST ALL COMPANIES WORKING UNDER PRIMARY CONTRACTOR PERMIT)</small></p> <p>COMPANY NAME: _____</p> <p>B. WORK DESCRIPTION:</p> <p><input type="checkbox"/> POD/DUMPSTER <input type="checkbox"/> CRANE <input type="checkbox"/> SCAFFOLDING <input type="checkbox"/> CONSTRUCTION USE*</p> <p>(EXPLAIN): <u>AERIAL AND UNDERGROUND PLACEMENT</u></p> <p><small>*EXCAVATION, LONG TERM USE FOR STORAGE OF MATERIAL/EQUIPMENT/WALKAROUND</small></p> <p>C. RIGHT OF WAY TO BE USED/CLOSED:</p> <p>STREET NAME 1: <u>403 COUNTRY CLUB DR.</u></p> <p>1ST INTERSECTING STREET NAME: _____</p> <p>2ND INTERSECTING STREET NAME: _____</p> <p><input type="checkbox"/> ROAD CLOSURE <input type="checkbox"/> LANE CLOSURE 1 <input type="checkbox"/> 2 <input type="checkbox"/> 3 <input type="checkbox"/></p> <p><input type="checkbox"/> SIDEWALK* <input type="checkbox"/> BIKE LANE <input type="checkbox"/> OTHER</p> <p>TRANSIT STOP? <input type="checkbox"/> Y <input type="checkbox"/> N PARKING LANE(S)** <input type="checkbox"/> Y <input type="checkbox"/> N <small>**NON-METERED</small></p> <p>START DATE: _____ END DATE: _____ # OF DAYS*: <u>10</u></p> <p>STREET NAME 2: _____</p> <p>1ST INTERSECTING STREET NAME: _____</p> <p>2ND INTERSECTING STREET NAME: _____</p> <p><input type="checkbox"/> ROAD CLOSURE <input type="checkbox"/> LANE CLOSURE 1 <input type="checkbox"/> 2 <input type="checkbox"/> 3 <input type="checkbox"/></p> <p><input type="checkbox"/> SIDEWALK* <input type="checkbox"/> BIKE LANE <input type="checkbox"/> OTHER</p> <p>TRANSIT STOP? <input type="checkbox"/> Y <input type="checkbox"/> N PARKING LANE(S)** <input type="checkbox"/> Y <input type="checkbox"/> N <small>**NON-METERED</small></p> <p>START DATE: _____ END DATE: _____ # OF DAYS*:</p> <p><small>*SIDEWALK CLOSURES FOR A PERIOD OR PERIODS TOTALING 24 HRS OR MORE SHALL INSTALL A WALKAROUND UNLESS OTHERWISE APPROVED DURING REVIEW</small></p> <p>STANDARD CLOSURE HOURS MON-FRI*: <u>9:00 AM - 3:00 PM & 6:00 PM - 9:00 PM</u></p> <p>STANDARD CLOSURE HOURS <input type="checkbox"/> *NON-STANDARD CLOSURE HOURS <input type="checkbox"/></p> <p>REQUESTED CLOSURE HOURS: _____ AM - _____ PM</p> <p><small>*non-standard hours may not be allowed near schools, on arterials, or other circumstances and are subject to approval during the permitting process</small></p> <p><small>BMC 14.09.0-10 allows work from 6 AM to 10 PM without violating the noise ordinance (7AM to 9PM for pneumatic hammers)</small></p>	<p>D. TRAFFIC CONTROL DEVICES*:</p> <p><input checked="" type="checkbox"/> CONES <input type="checkbox"/> ARROWBOARD</p> <p><input type="checkbox"/> LIGHTED BARRELS <input type="checkbox"/> TYPE 3 BARRICADES</p> <p><input type="checkbox"/> FLAGGERS <input type="checkbox"/> BPD OFFICER</p> <p><small>*PROVIDING MUTCD COMPLIANT TEMPORARY TRAFFIC CONTROL DEVICES AND MAINTENANCE OF TRAFFIC (NOT) PLAN IS YOUR RESPONSIBILITY AND REQUIRED See page 3 for additional MOT resources; the graph paper can be used for your MOT site plan if needed or you can submit a separate sheet</small></p> <p>E. METERED PARKING SPACES NEEDED: <input type="checkbox"/> Y <input checked="" type="checkbox"/> N</p> <p><small>IT IS THE RESPONSIBILITY OF THE APPLICANT TO RESERVE PARKING METER(S) APPLICATION LOCATED: https://bloomington.in.gov/transportation/parking/ moving OR CONTACT PARKING SERVICES WITH QUESTIONS AT (812)349-3436</small></p> <p>F. IS THIS A <input type="checkbox"/> CBU* <input type="checkbox"/> COUNTY* <input type="checkbox"/> IU* <input type="checkbox"/> NP* PROJECT?</p> <p>PROJECT NAME: <u>COUNTRY CLUB DRIVE</u></p> <p>PROJECT #: <u>A029ADZ</u></p> <p>PROJECT MGR.: <u>ZACHARY A. DECKARD</u></p> <p>PROJECT MGR. #: <u>812 - 334 - 4585</u></p> <p><small>*CBU = CITY OF BLOOMINGTON UTILITIES *COUNTY = MONROE COUNTY *IU = INDIANA UNIVERSITY *NP = NOT-FOR-PROFIT AGENCY</small></p> <p>G. EXCAVATIONS:</p> <p>SQ FT OF PAVEMENT* EXCAVATIONS: _____</p> <p><small>*PAVEMENT INCLUDES: IN OR UNDER CONCRETE, OR ASPHALT INCLUDING CURBS</small></p> <p>SQ FT OF NON-PAVEMENT* EXCAVATIONS: <u>2</u></p> <p><small>*DIRT, GRASS, GRAVEL, LANDSCAPE AREA OR OTHER UNPAVED SURFACE</small></p> <p>LINEAL FT OF BORE*: <u>70'</u></p> <p><small>*BORE PITS SHALL BE CALCULATED AS SQ FT EXCAVATIONS</small></p> <p># OF POLE INSTALLATIONS/REMOVAL: _____</p> <p>SQ FT OF SIDEWALK RECONSTRUCTION*: _____</p> <p><small>*CONCRETE OR ASPHALT SIDEWALK/PATH BEING IMPROVED/REPLACED</small></p> <p>SQ FT OF SIDEWALK NEW CONSTRUCTION*: _____</p> <p><small>*CONCRETE OR ASPHALT SIDEWALK/PATH THAT IS NEW INFRASTRUCTURE</small></p> <p># RESIDENTIAL DRIVEWAY INSTALLATION: _____</p> <div style="border: 1px solid black; padding: 5px; margin-top: 10px;"> <p align="center">Indiana 811</p> <p align="center"><small>Know what's below. Call before you dig.</small></p> </div> <p><small>TO SUBMIT A LOCATE REQUEST 24 HRS A DAY, 7 DAYS A WEEK CALL 811 OR 800-382-5544 CALL 2 WORKING DAYS BEFORE YOU DIG. IT'S THE LAW.</small></p> <p>H. INDEMNIFICATION AGREEMENT:</p> <p><small>The petitioner/applicant hereby agrees to hold harmless, defend and to indemnify the City of Bloomington from or against all claims, action, damages and expenses, including but not limited to reasonable attorney's fees or any alleged injury and/or death to any person or damage to any property arising or alleged to have arisen out of any act of commission or omission on the part of the petitioner/applicant, his/her heirs, successors, or assigns regardless of whether such acts are the direct or indirect result of the public right-of-way use pursuant to this permit grant.</small></p> <p>I AFFIRM, UNDER THE PENALTIES FOR PERJURY, THAT THE FOREGOING REPRESENTATIONS ARE TRUE.</p> <p>PRINT NAME: <u>BRIAN BUSICK</u></p> <p>SIGNATURE: <u>Brian Busick</u></p> <p>DATE: <u>6/2/2022</u></p>
--	---

For Administration Use Only (applicable to CLOSURE approval)

Approved By: _____ BPW City Engineer Director Date: _____

Staff Representative: _____ Phone#: _____ Date: _____

LINEAL Contracting Inc.

2922 Mitchell Road
Bedford, IN 47421
Office: 812-277-0477
Fax: 812-275-6706

June 30, 2022

Board of Public Works
City of Bloomington
041 North Morton Street
Bloomington, IN 47404

RE: ROW Permits in The Stands, and the areas of S Rogers, Rockport, and Country Club

Dear Board Members:

AT&T is planning FTTH projects in the areas of The Stands, S Rogers, Rockport, and Country Club. These projects will be implemented by Lineal Contracting. In order to facilitate this project, Lineal Contracting is respectfully requesting access to the City of Bloomington ROW as described in the submitted plans. Where required, and as described in the attached, Lineal Contracting will be implementing the State of Indiana approved Maintenance of Traffic Control Plan.

There will be no long term closures of roads on any of these projects, however there will be vehicles parked on the shoulders while work is being completed. Signs and flaggers will be present while any roadway is obstructed. These areas are all identified on the plans submitted through the Planning Department.

Prior to construction starting on either project, Lineal Contracting will place AT&T provided door hangers on all affected properties. These door hangers will explain the nature of the project, the purpose, and provide a contact number should any issues arise.

Lineal Contracting respectfully requests the Board of Public Works approves the ROW permits referenced above.

Regards,
Brian Busick
Lineal Contracting, Inc

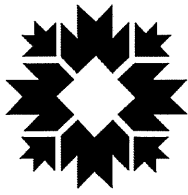

City of Bloomington
 Engineering Department
 bloomington.in.gov

401 N Morton St Suite 130
 PO Box 100
 Bloomington, IN 47404

Phone: (812) 349-3913
 Fax (812) 349-3520
 Email: engineering@bloomington.in.gov

Right Of Way Excavation Permit

Company	Lineal Contracting	Status	Active	Permit	C22-ROW-198
Responsible	Busick, Brian	Inspector	Paul Kehrberg	Date Issued	07/13/2022
Project	New fiber build	Permit Fee	\$307.0	Start Date	07/13/2022
Bond Amount	\$15,000.00	Expiration Date	08/22/2022	Invoice	Billed

Address	Cut Type	Utility	Description	Width	Length
S Rogers St	Bore	Telecom	Bore under streets and have temporary lane closures for overhead work per plans. Follow MUTCD guidance for all work within the right of way. Seed and straw disturbed areas within 14 days.	1	330
The Stands Drive	Bore	Telecom	Bore under streets in The Stands per plans. Follow MUTCD guidance for all work within the right of way. Seed and straw disturbed areas within 14 days.	1	740

Special Provisions

Application fee: \$100
 Bore fee: \$107
 Lane closure fee \$100

Standards Conditions of Approval

- 1 - Permittee is required to call the Engineering Department at 812-349-3913 for inspection of any work at the City of Bloomington Right of way prior to placing any concrete, or at any point specified in the Specific Conditions of Approval.
- 2 - This approval only covers concerns within the jurisdictions of the City of Bloomington Engineering Department, other entities or agencies may also need to grant approval for work done in the course of this project.
- 3 - Projects shall conform to all current A.D.A.,(Americans with Disabilities Act) requirements.
- 4 - All utility work shall conform to specifications to be obtained from the owner of the affected utility, and work on said utility shall be performed only with expressed permission of its owner. It shall be the responsibility of the permittee to obtain any necessary inspections or approvals from the owner of the utilities involved.
- 5 - Permittee shall be responsible for supplying and placing all required signs and barricades. All signs and barricades, and their placement, shall conform to current M.U.T.C.D. and I.N.D.O.T. standards. All required traffic control measures shall be in place before work begins.
- 6 - Erosion control measures complying with Bloomington Municipal Code 20.05.040 are required to be in place during the period of any earth disturbing activities, and remain in place until the site is stabilized.
- 7 - All bonding must remain current until a written release of such bonding is given by a representative of the City of Bloomington Engineering Department.
- 8 - Any work in a street shall conform to the City of Bloomington Street Cut Requirements. Copies of these requirements are available from Engineering Department. All damaged Public Improvements must be repaired to prior or improved conditions.
- 9 - Any brick or inlaid limestone sidewalks, or brick surfaced streets, shall remain undisturbed, unless specific permission is given by a representative of the Engineering Department. If they are disturbed the surface material shall be taken up, saved, and re-installed to City of Bloomington specifications. Backfill methods and materials must also meet these specifications.
- 10 - Any damage to any underground facility or utility must be reported immediately to the City of Bloomington Engineering Department and the owner of the facility or utility (if known). If not, the permittee will be required to re-excavate the damaged facility or utility, at their expense, to demonstrate that repairs have been made to the satisfaction of the owner of the damaged facility or utility,
- 11 - Any above ground appurtenances (line markers, switch boxes, meters, etc.), or structures, to be placed in the City Right of Way must be approved the City of Bloomington Engineering Department prior to installation.
- 12 - All existing regulatory signs (STOP, YIELD, NO PARKING, etc.) that are owned by the City of Bloomington shall be removed and replaced only by the City of Bloomington Traffic Division. Any regulatory signs removed, or installed, by the permittee are subject to removal or replacement by the Traffic Division with Permittee being billed for time and materials.

Paul Kehrberg

PLACE 938' OF NEW 6M STRAND
FROM 150-659-BLM (PRINT 17) TO P2 (PRINT 23)

R 2637-1 S MILTON DR
EVOLV4/100TIP (PPA) 822C
PON403CC, 117-120

S MILTON DR

TO CO
SEE PRINT 17

125'

MGNV

HOA=13'7"
150-667-BLM

R 2614-1 S ROGERS ST
EVOLV4/100TIP (PPA)
PON403CC, 125-128

102'

MGNV

150-668-BLM
HOA=16'4"

R 2620-1 S ROGERS
EVOLV4/100TIP (PPA)
PON403CC, 121-124

5

5

170'

LASH TO
NEW STRAND

150-758-BLM
HOA=16'1"

MGNV

176'

DIRECTION OF FNAP
CABLE PLACEMENT

S ROGERS ST

PLACE 938' OF NEW 6M STRAND
FROM 150-669-BLM(PRINT 17) TO P2 (PRINT 23)

822C
CONT-FI-CABLE
187 EXEMPT MATERIAL ONLY
187 SVA ONLY - ASH/GREY/BLK
PID#200008986
ORDER 200' TAIL
FOR F 2706-1

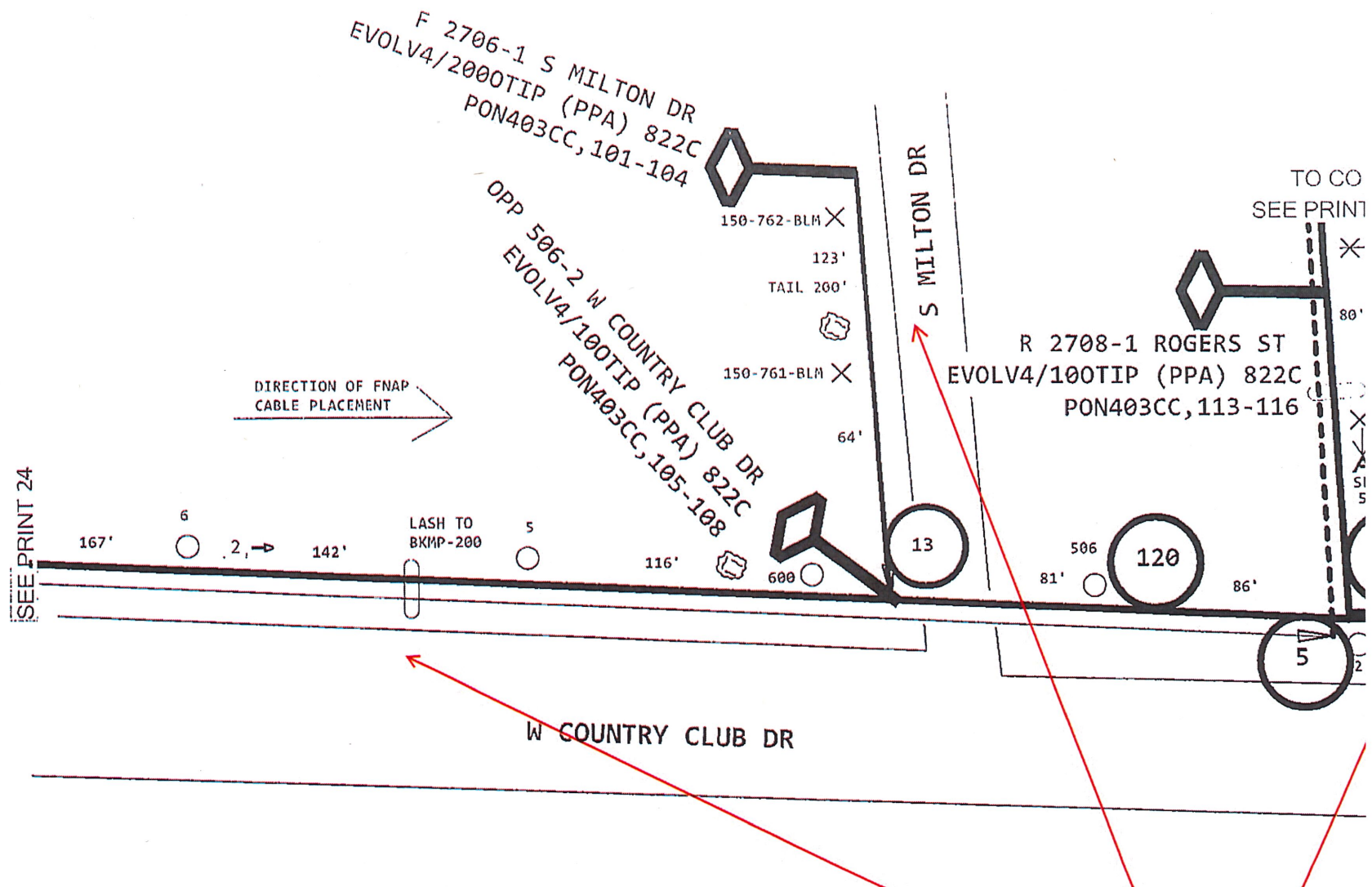

INT 25

F 716-2 W COUNTRY CLUB DR
EVOLV4/100TIP (PPA) 822C
PON403CC, 85-88

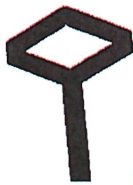

716

F 710-1 W COUNTRY CLUB DR
EVOLV4/500TIP (PPA) 822C
PON403CC, 93-96

F 712-2 W COUNTRY CLUB DR
EVOLV4/100TIP (PPA) 822C
PON403CC, 89-92



LASH TO

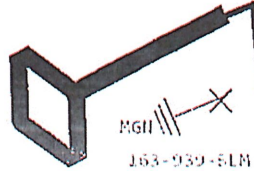

163-939-BLM

PID#200008988
ORDER 500' TAIL
FOR F 710-1

163-940-BLM X

500' TAIL

121'

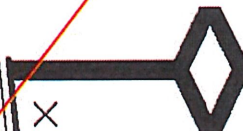

163-941-BLM

F 704-1 W
EVOLV4/20
PON403CC,

822C
CONT-PL-CABLE
156 EXEMPT MATERIAL ONLY
156 SVA ONLY - LASH CABLE/INN

200' TAIL

156'

PID#200008986
ORDER 200' TAIL
FOR F 704-1



LASH TO
BKMS-25



86

44

130'

CONT-PL-CABLE
156 EXEMPT MATERIAL ONLY
156 SVA ONLY - LASH CABLE/INN

LASH TO
BKMS-25

ROLLING
CONTROL
HANGING
CABLE. SI-
PLACE FO
CONTROL
ON SITE

812-2 W COUNTRY CLUB DR
EVOLV4/100TIP (PPA) 822C
PON403CC, 81-84

902-2 W COUNTRY CLUB DR
EVOLV8/100TIP (PPA) 822C
PON403CC, 73-80

DIRECTION OF ENAP
CABLE PLACEMENT

S BANTA AVE

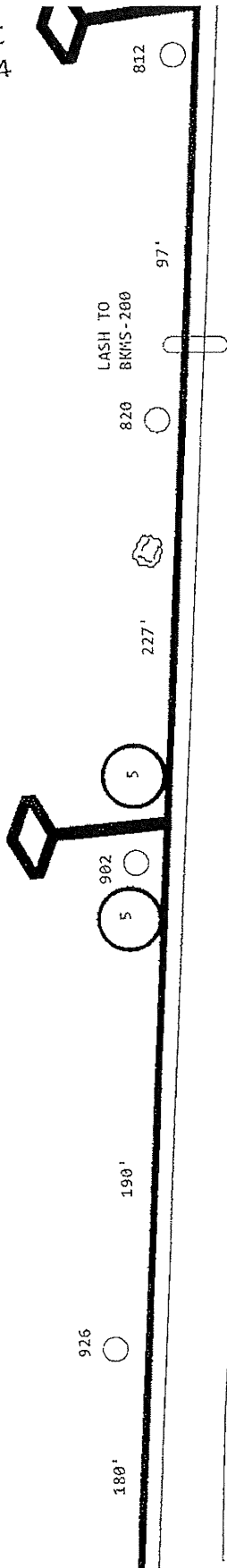

W COUNTRY CLUB DR

SEE PRINT 26

SEE PRINT 27

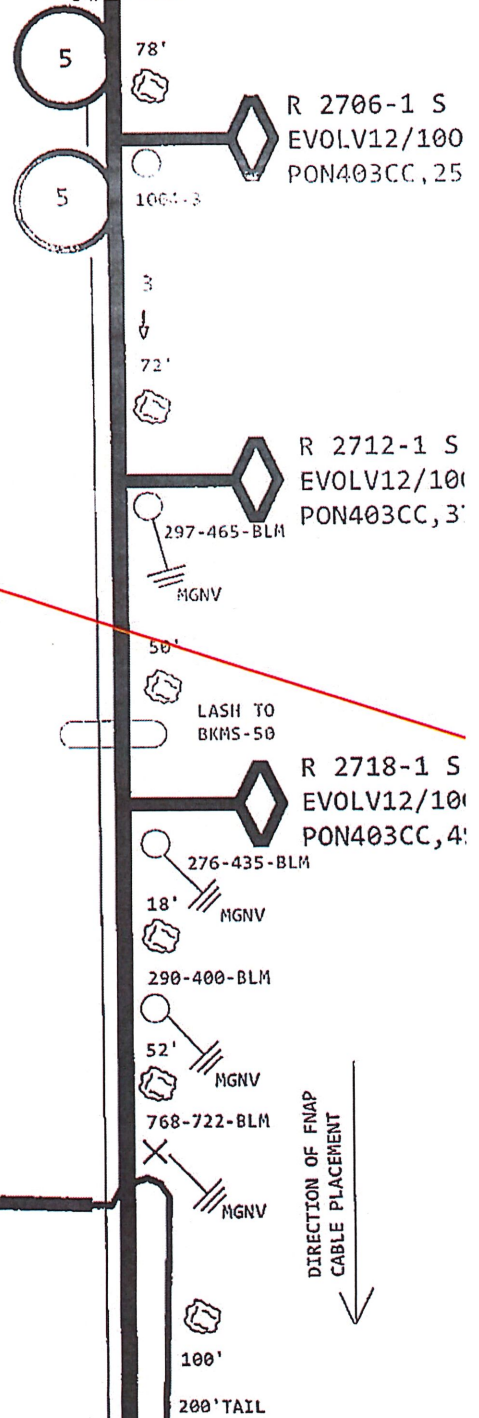

AERIAL TRUCK
PARKED FOR AERIAL
EASEMENT WORK

ROLLING TRAFFIC
CONTROL FOR
HANGING AERIAL
CABLE SIGNS IN
PLACE FOR TRAFFIC
CONTROL. FLAGGERS
ON SITE.

522C
CONT-PL-CABLE
118 EXEMPT MATERIAL ONLY
118 SVA ONLY - LASH CABLE/HHH
PID#200009014
ORDER 200' TAIL
FOR R1004-2

R 1004-2 W COUNTRY CLUB DR
EVOLV12/200TIP (PPA) 822C
PON403CC, 61-72

DIRECTION OF FMAP
CABLE PLACEMENT

DATE: 11/13/03
DRAWN BY: J. J. JONES
CHECKED BY: J. J. JONES
SCALE: AS SHOWN

TYPE OF PCD
DEPT. EMPLOYEES ONLY
FOR OFFICIAL USE ONLY
PROPERTY OF THE U.S. DEPARTMENT OF JUSTICE

PLACE 98' OF NEW 6M STRAND
FROM 168-733-BLM TO 168-732-BLM

PL 6M DG
PL 1" HELIX
H=21'
L=15"

HGNV
168-733-BLM
HOA=21'

98' LASH TO
NEW STRAND

MGNV
NEW
168
HOA=3

R 2600-1 S BANTA AVE
EVOLV8/100TIP (PPA) 822C
PON403CC, 17-24

TO W COUNTRY CLUB DR

1004E

LASH TO
BKMS-50

3

SEE PRINT 26
TO CO

DIRECTION OF FNAP
CABLE PLACEMENT

KF=4.844
F 2700-1 S BANTA AVE
EVOLV4/100TIP (PPA) 822C
PON403CC, 17-24

KF=4.68
F 1016-2 W COUNTRY CLUB DR
EVOLV4/100TIP (PPA) 822C
PON403CC, 5-8

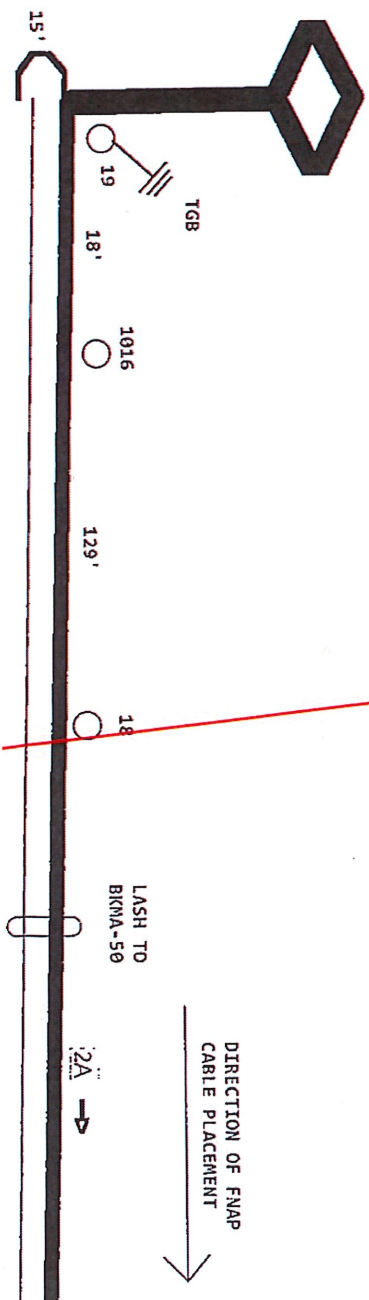

ROLLING TRAFFIC
CONTROL FOR
HANGING AERIAL
CABLE: SIGNS IN
PLACE FOR TRAFFIC
CONTROL. FLAGGERS
ON SITE

TO S BANTA AVE

DIRECTION OF FANAP
CABLE PLACEMENT
→

2A →

W RALSTON DR

MGNV

162-724-BLM
20' RISCR

S BANTA AVE

2604

2610

18'

99

49

162-810-BLM

2605

2607

BORE TRUCK
PARKED FOR
BORING. SIGNS IN
PLACE FOR TRAFFIC
CONTROL. FLAGGERS
AVAILABLE IF
NEEDED

CONSTRUCTION NOTE
PLACE HH AT BASE OF POLE
& UTILIZE POLE FOR DROPS

822C
@PPF
352 TESTING FIBER FACILITIES

95C
@PPF
4 TESTING FIBER FACILITIES

UNIDIRECTIONAL
TESTING

UNIDIRECTIONAL
TESTING

EML-PPF-TO FST @1310NM = 2.8 DB
EML-PPF-TO FST @1490NM = 2.9 DB

21M
7
TREE
3104 EXEMPT MATERIAL ONLY
3104 SVA ONLY - MAINTENANCE TR

21M
6
TREE
4372
4678

BULK CREDIT FOR
TREE TRIMMING
WITH NON-VEH ACCESS

RUI
TF
WIT

W COUNTRY CLUB DR

W COUNTRY CLUB DR

ROLLING TRAFFIC
CONTROL TO HANG
AERIAL CABLE. SIGNS
IN PLACE FOR
TRAFFIC CONTROL.
FLAGGERS ON SITE
AT ALL TIMES

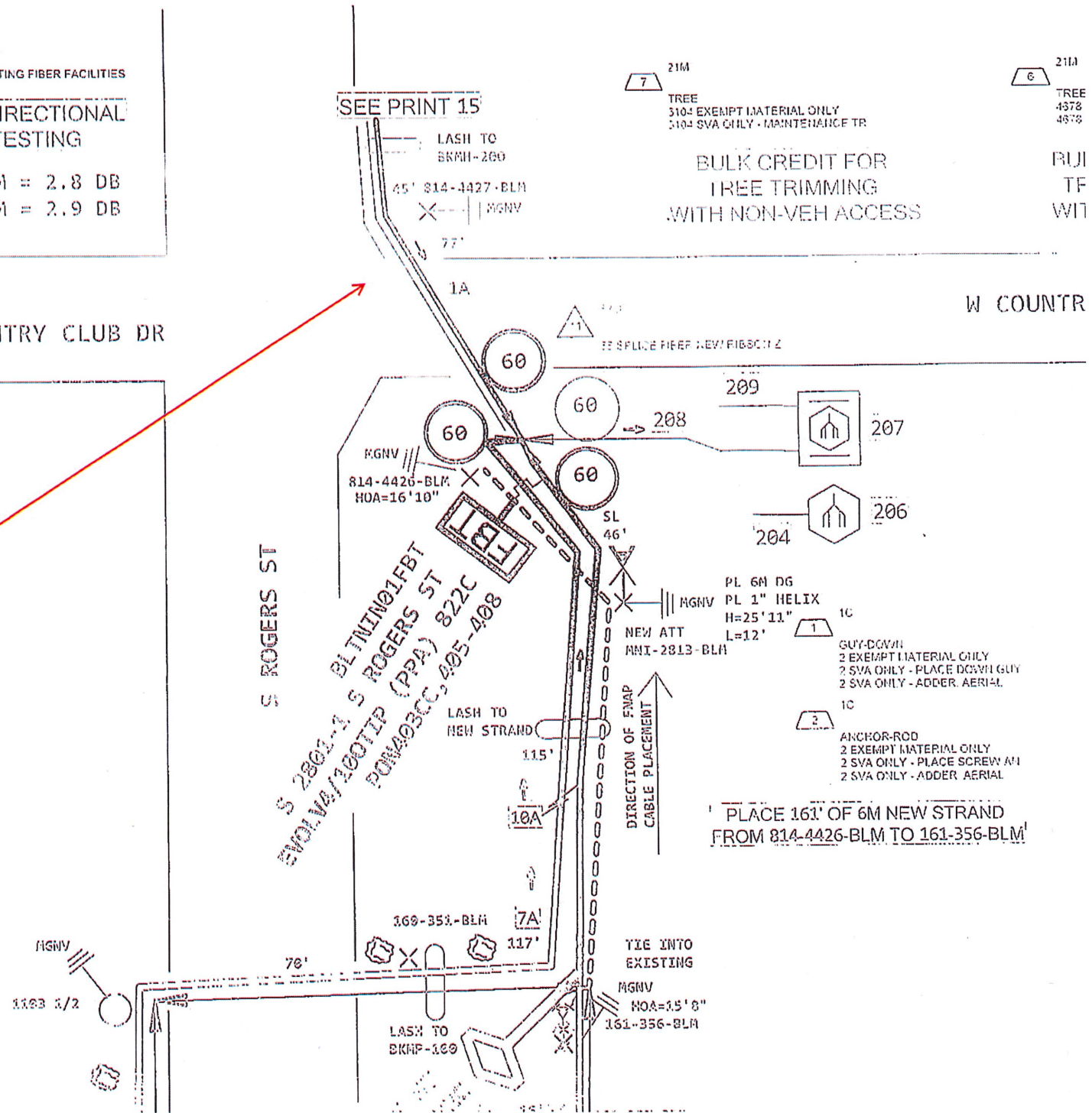

SEE PRINT 17

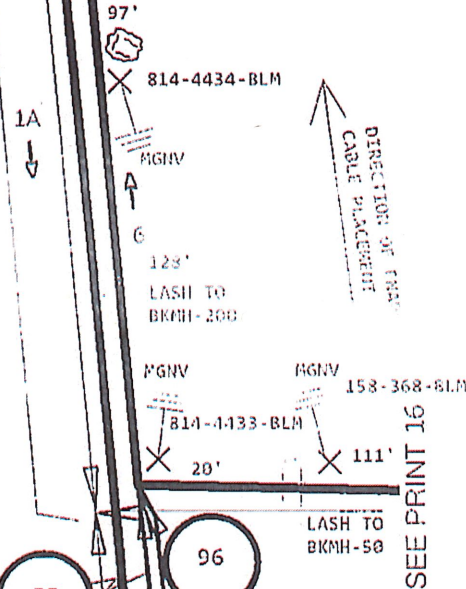

S ROGERS ST

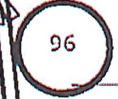

W WATSON ST

PID: 200008986
ORDER 200' TAIL
FOR F2709-2

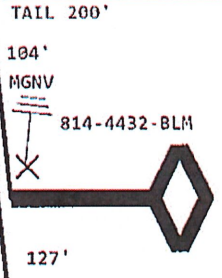

822C
CONT-PL-CABLE
104 EXEMPT MATERIAL ONLY
104 SVA ONLY - LASH CABLE WITH

F 2709-2 S ROGERS ST
EVOLV4/2000TIP (PPA) 822C
PON403CC, 229-232

ROLLING TRAFFIC CONTROL FOR HANGING AERIAL CABLE. SIGNS IN PLACE FOR TRAFFIC CONTROL. FLAGGERS ON SITE

400' TAIL

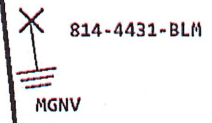

LASH TO BKMH-200

114'

ALLEY



822C
CONT-PL-CABLE
345 EXEMPT MATERIAL ONLY

TO CO
SEE PRINT 15

W WATSON ST

LASH TO
BKMP-50

F 408-2 W WATSON ST
EVOLV8/1000TIP (PPA) 822C
PON403CC, 217-224

158-369-BLM

158-370-BLM

133'

92'

NGNV

DIRECTION OF FNAP
CABLE PLACEMENT

S MADISON ST

SON ST

F 2627-2 S MADISON ST
EVOLV4/100TIP (PPA) 822C
PON403CC, 213-216

5

5

158-371-BLM

158-372-BLM

90'

NGNV

W WATSON ST

KF=2.42A
F 2626-
EVOLV
PON

15'

ENGINEERING

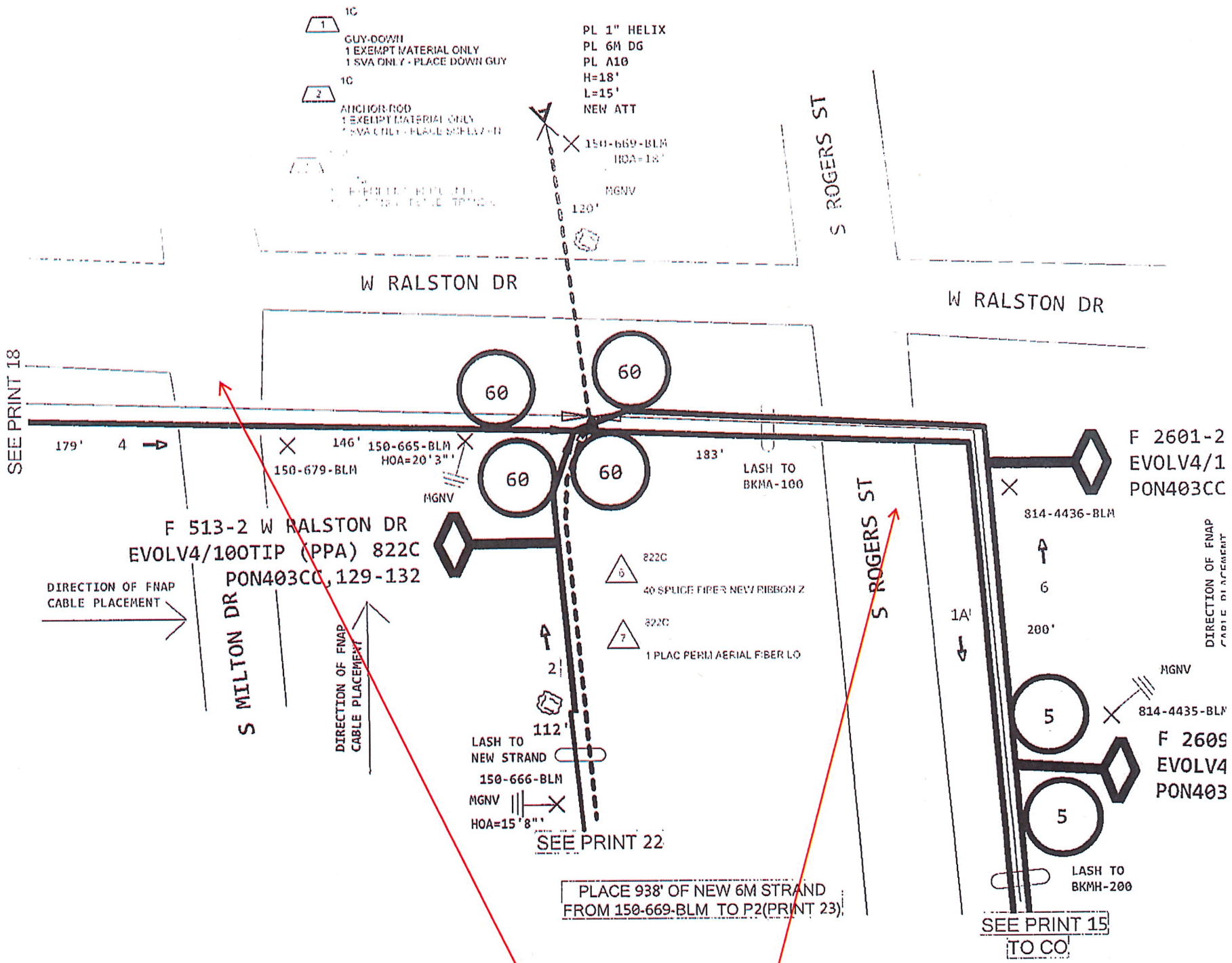

- 1C
1 GUY-DOWN
1 EXEMPT MATERIAL ONLY
1 SVA ONLY - PLACE DOWN GUY
- 2C
1 ANCHOR ROD
1 EXEMPT MATERIAL ONLY
1 SVA ONLY - PLACE DOWN GUY

PL 1" HELIX
PL 6M DG
PL A10
H=18'
L=15'
NEW ATT

F 513-2 W RALSTON DR
EVOLV4/100TIP (PPA) 822C
PON403CC, 129-132

F 2601-2
EVOLV4/1
PON403CC

F 2609
EVOLV4
PON403

PLACE 938' OF NEW 6M STRAND
FROM 150-669-BLM TO P2(PRINT 23)

SEE PRINT 18

SEE PRINT 22

SEE PRINT 15
TO CO.

DIRECTION OF FNAP
CABLE PLACEMENT

DIRECTION OF FNAP
CABLE PLACEMENT

DIRECTION OF FNAP
CABLE PLACEMENT

S MILTON DR

S ROGERS ST

S ROGERS ST

W RALSTON DR

W RALSTON DR

179' 4

146' 150-665-BLM
150-679-BLM
HOA=20'3"

150-669-BLM
HOA=18'

183' LASH TO
BKMA-100

814-4436-BLM

6
200'

814-4435-BLM

LASH TO
NEW STRAND
150-666-BLM
MGNV
HOA=15'8"

LASH TO
BKMH-200

- 822C
40 SPLICE FIBER NEW RIBBON Z
- 822C
1 PLAC PERM AERIAL FIBER LO

2

112'

1A'

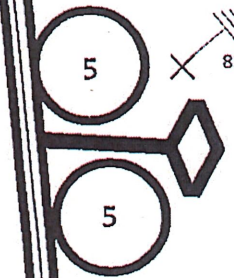
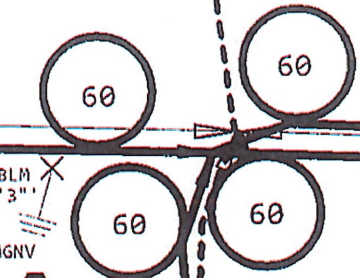
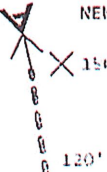

IX
2
AUG 10 2010
10:00 AM
GENERAL
ELECTRICAL
DRAWING

W RALSTON DR

SEE PRINT 19

CREATE FALSE DE
AND TIE INTO EXISTING



F 811-2 W RALSTON DR
EVOLV8/100TIP (PPA) 822C
PON403CC,177-184

F 717-2 W RALSTON DR
EVOLV4/100TIP (PPA) 822C
PON403CC,185-188

F 713-2 W RALSTON DR
EVOLV4/100TIP (PPA) 822C
PON403CC,189-192

F 621-2 W RALSTON DR
EVOLV4/100TIP (PPA) 822C
PON403CC,193-196

PLACE 1404' OF 6M NEW STRAND
FROM 150-721-BLM TO 179-368-BLM(PRINT 20)

DIRECTION OF FMAP
CABLE PLACEMENT

ROLLING TRAFFIC
CONTROL END

PLACE 1404' OF 6M NEW STRAND
FROM 150-721-BLM(PRINT 18) TO 179-368-BLM(PRINT 20)

15' LOOP FOR W RALSTON DR
TRIPLE TETHER

SEE PRINT 20

S BANTA AVE

40'
MGV
162-734-BLM
HOA=17'
20' RISER

90'

MT=210'

TAIL=300'

145'

LASH TO
NEW STAND

150-726-BLM
HOA=18'8"
MGV

130'

5 →

150-725-BLM
HOA=18'
MGV

160'

60'

DIRECTION OF FHAP
CABLE PLACEMENT

PID#200008966
ORDER 300' TAIL
FOR F2605-1

F 909-2 W RALSTON DR
EVOLV4/100TIP (PPA) 822C
PON403CC, 161-164

F 905-2 W RALSTON DR
EVOLV4/100TIP (PPA) 822C
PON403CC, 165-168

85C
1
CONT-PL-CABLE
210 EXEMPT MATERIAL ONLY
210 SVA ONLY - PLACE ITEM IN

822C
3
1 PLACE AND CL EAT RISER CAB

F 2605-1 S BANTA AVE
EVOLV4/300TIP (PPA) 85C
PON403CC, 157-160

49

ROLLING TRAFFIC
CONTROL FOR
HANGING AERIAL
CABLE. SIGNS IN
PLACE FOR TRAFFIC
CONTROL. FLAGGERS
ON SITE

BORE TRUCK
PARKED FOR BORE.
SIGNS IN PLACE FOR
TRAFFIC CONTROL.

49 F 2605
HH-13X19X12(PPA) 4C

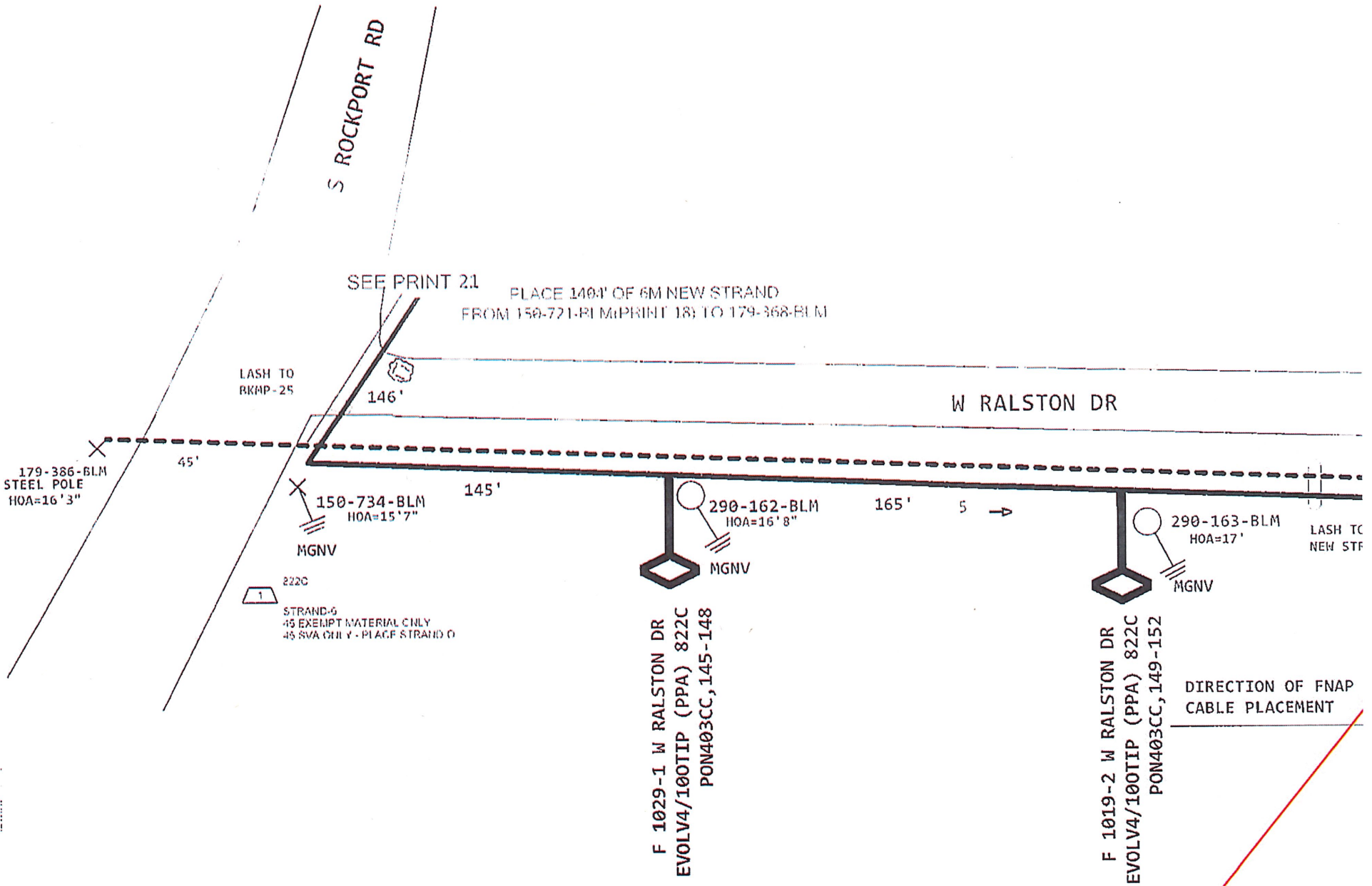

S ROCKPORT RD

SEE PRINT 2.1

PLACE 140' OF 6M NEW STRAND
FROM 150-721-BLM (PRINT 18) TO 179-368-BLM

LASH TO
BKMP-25

146'

W RALSTON DR

179-386-BLM
STEEL POLE
HOA=16'3"

45'

150-734-BLM
HOA=15'7"

145'

MGNV

822C

1

STRAND-G
45 EXEMPT MATERIAL ONLY
45 SVA ONLY - PLACE STRAND G

290-162-BLM
HOA=16'8"

165'

5



MGNV

290-163-BLM
HOA=17'

LASH TO
NEW STR

MGNV

F 1029-1 W RALSTON DR
EVOLV4/100TIP (PPA) 822C
PON403CC, 145-148

F 1019-2 W RALSTON DR
EVOLV4/100TIP (PPA) 822C
PON403CC, 149-152

DIRECTION OF FNAP
CABLE PLACEMENT

ROLLING TRAFFIC
CONTROL FOR
HANGING AERIAL
CABLE. SIGNS IN
PLACE FOR TRAFFIC

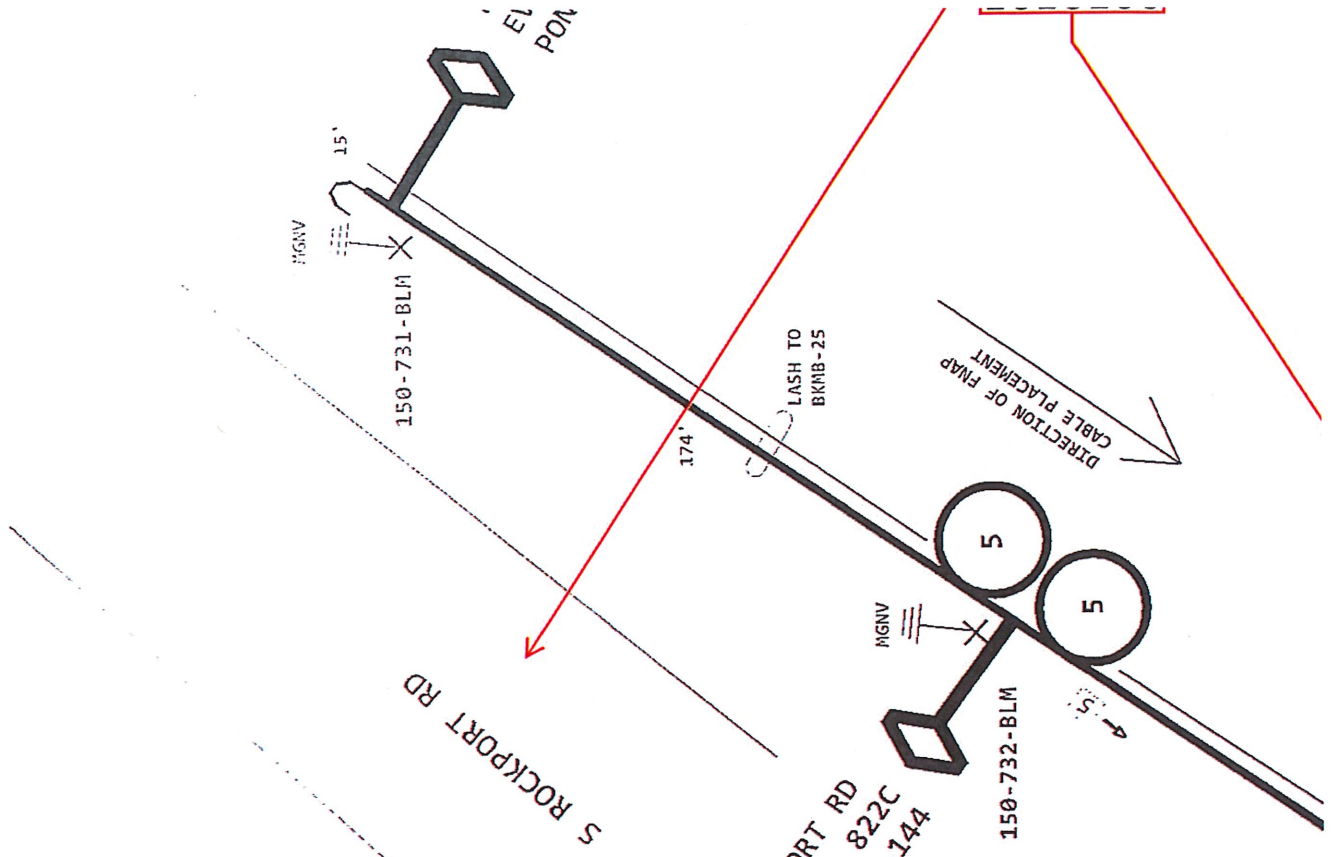

OPP 2616-1 S ROCKPORT RD
EVOLVA/100TIP (PPA) 822C
POM403CC, 141-144



91 364' INNERDUCT1-2" (PP)

TO CO
SEE PRINT 57

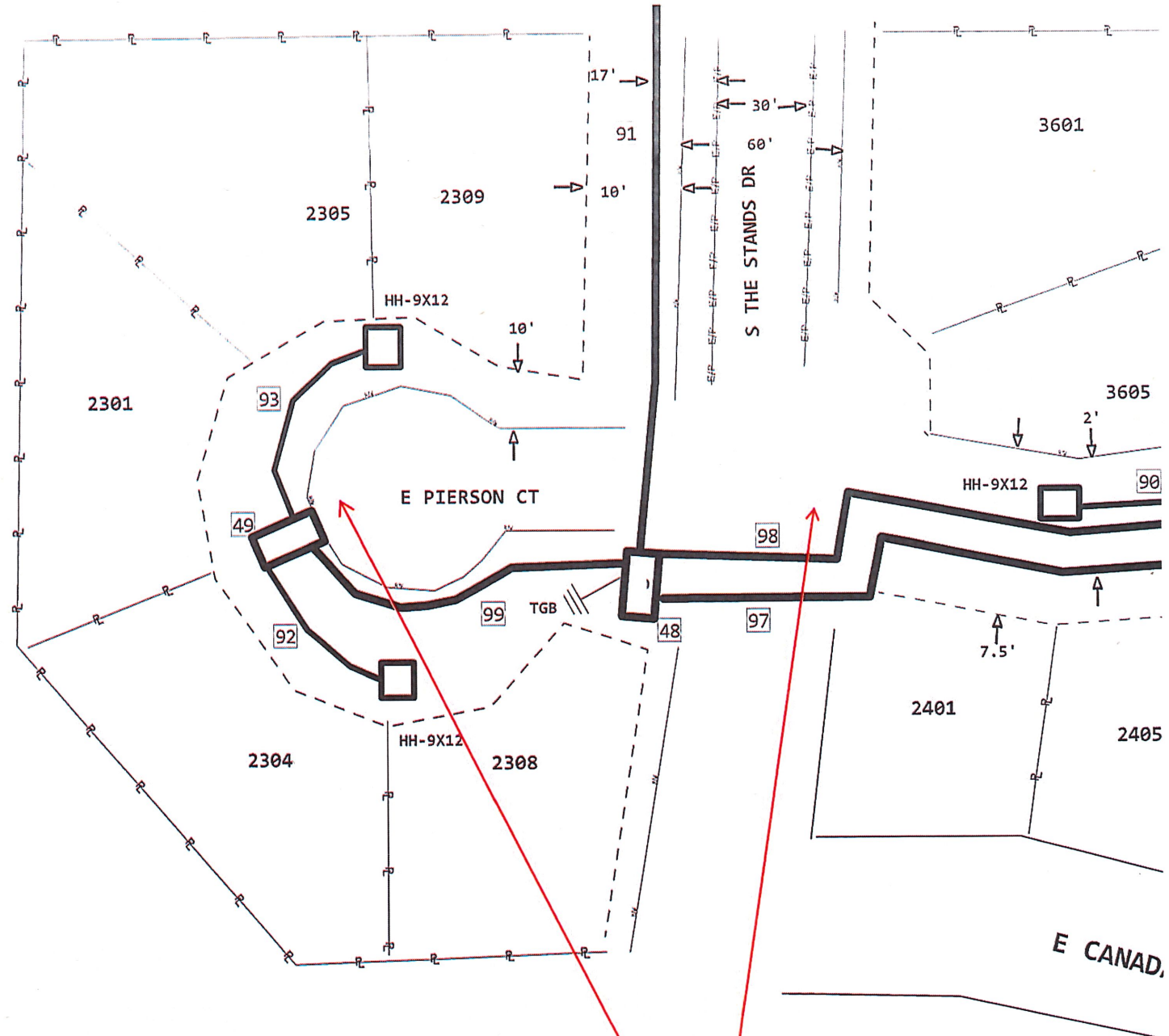

845C
 11 HH-9X12
 3 EXEMPT MATERIAL ONLY
 3 SVA ONLY - PLACE/REPLACE

4C
 10 HH-13X19X12
 4 EXEMPT MATERIAL ONLY
 4 SVA ONLY - PLACE/REPLACE

49 F2304
 HH-13X19X12 (PPA) 4C
 1 X 1.5 X 1 = 1.5

48 F2308
 HH-13X19X12 (PPA) 4C
 1 X 1.5 X 1 = 1.5

SEE PRINT 61

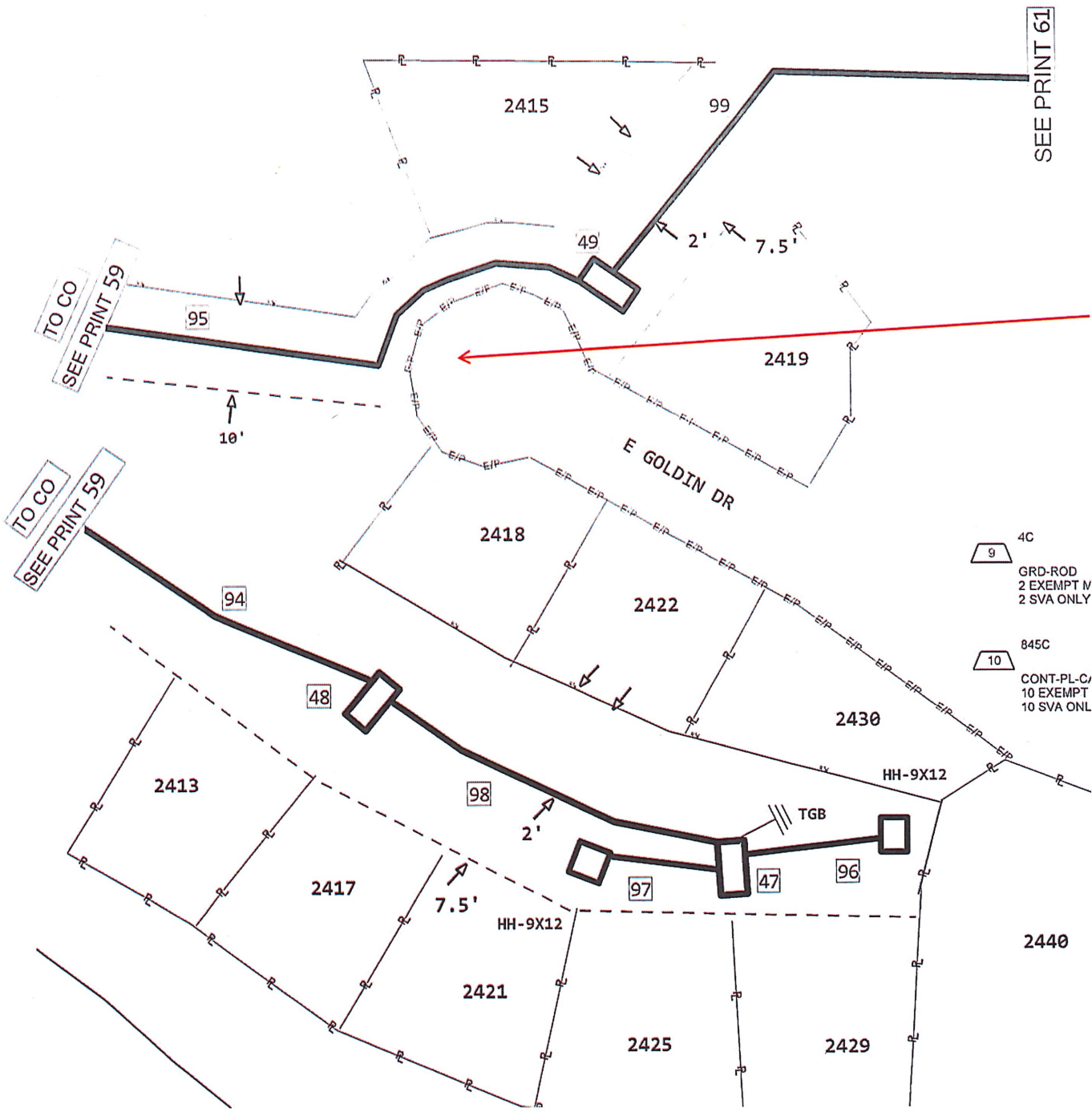

49 F2419
 HH-13X19X12 (PPA) 4C
 1 X 1.5 X 1 = 1.5

48 R2413
 HH-13X19X12 (PPA) 4C
 1 X 1.5 X 1 = 1.5

47 R2429
 HH-13X19X12 (PPA) 4C
 1 X 1.5 X 1 = 1.5

5 4C
 HH-13X19X12
 3 EXEMPT MATERIAL ONLY
 3 SVA ONLY - PLACE/REPLACE

6 845C
 HH-9X12
 2 EXEMPT MATERIAL ONLY
 2 SVA ONLY - PLACE/REPLACE

9 4C
 GRD-ROD
 2 EXEMPT M
 2 SVA ONLY

10 845C
 CONT-PL-C/
 10 EXEMPT
 10 SVA ONL

2440

TO CO
SEE PRINT 60

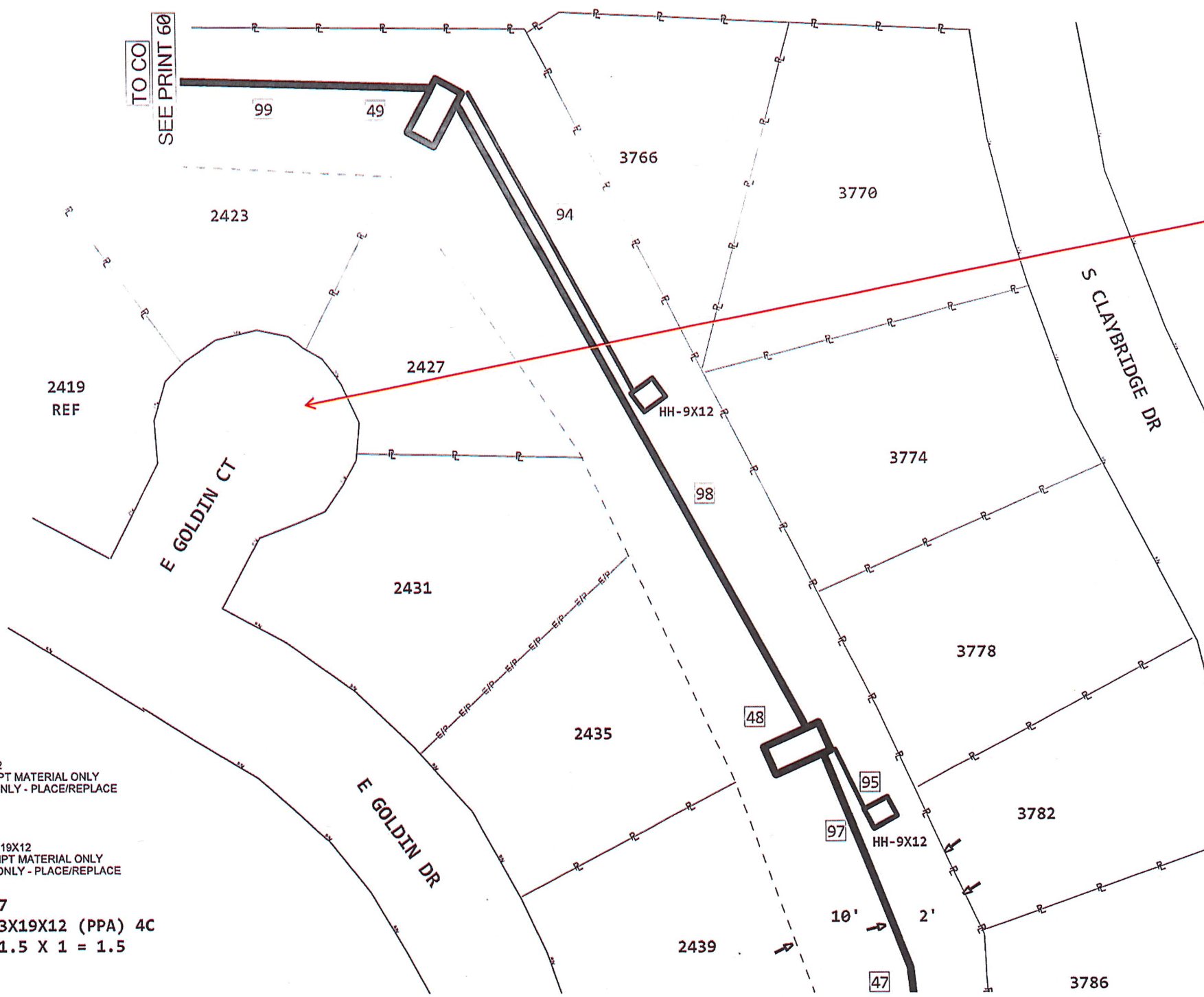

7 845C
 HH-9X12
 2 EXEMPT MATERIAL ONLY
 2 SVA ONLY - PLACE/REPLACE

6 4C
 HH-13X19X12
 3 EXEMPT MATERIAL ONLY
 3 SVA ONLY - PLACE/REPLACE

49 R2427
 HH-13X19X12 (PPA) 4C
 1 X 1.5 X 1 = 1.5

TO CO
SEE PRINT 6:

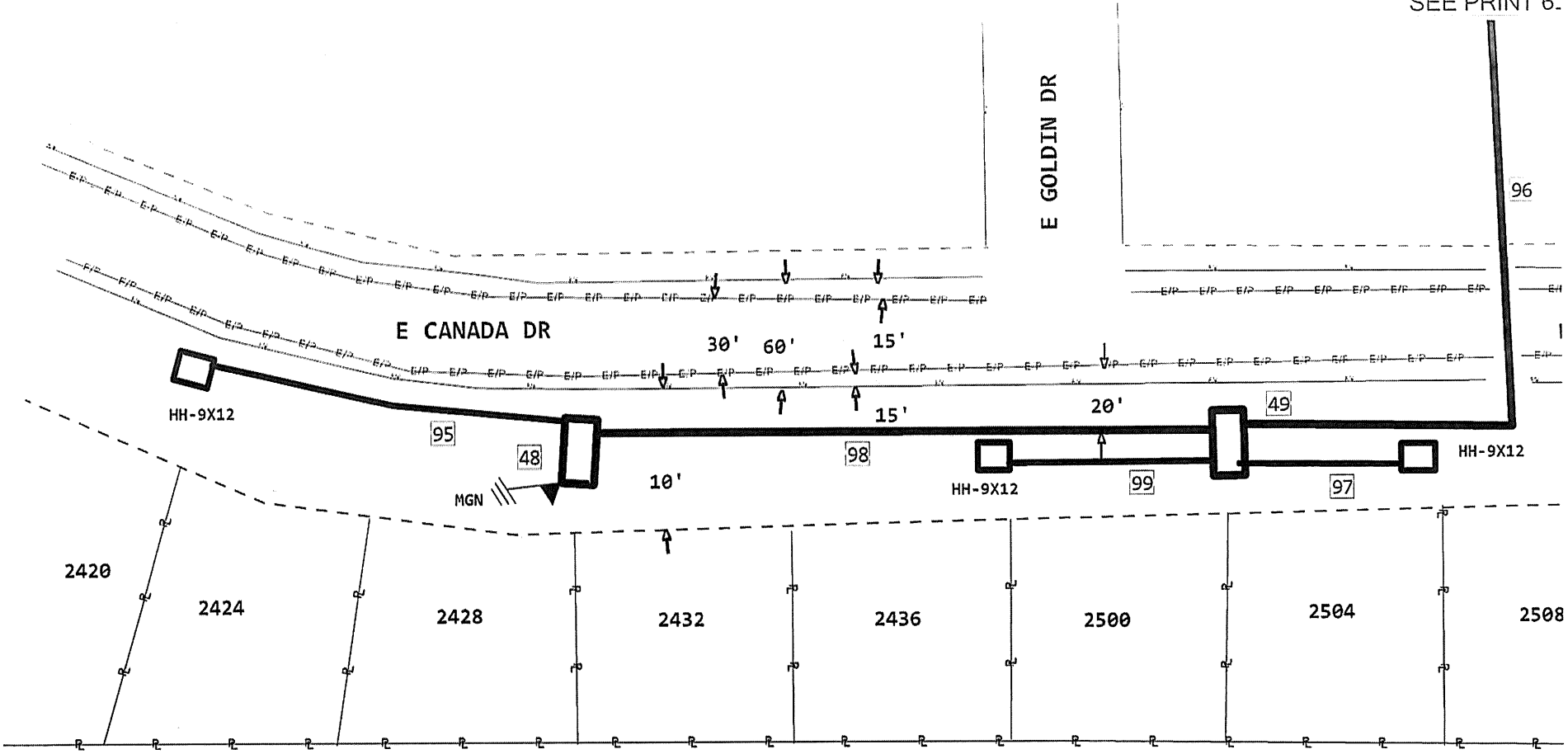

- 4C
5
HH-13X19X12
2 EXEMPT MATERIAL ONLY
2 SVA ONLY - PLACE/REPLACE
- 845C
6

1 4C

INNERDUCT1-2"
440 EXEMPT MATERIAL ONLY
440 BURY, ANY METHOD, ANY DEP

99 440' INNERDUCT1-2" (PPA) 4C

2 4C

INNERDUCT1-2"
226 EXEMPT MATERIAL ONLY
226 BURY, ANY METHOD, ANY DEP

94 226' INNERDUCT1-2" (PPA) 4C

3 845C

INNERDUCT1-1.25"
100 EXEMPT MATERIAL ONLY
100 BURY, ANY METHOD, ANY DEP DURALINE

98 100' INNERDUCT1-1.25" (PPA) 845C

2 PRINT 57

97 480' INNERDUCT1-2" (PPA) 4C

4 845C

INNERDUCT1-1.25"
100 EXEMPT MATERIAL ONLY
100 BURY, ANY METHOD, ANY DEP

96 100' INNERDUCT1-1.25" (PPA) 845C

3 PRINT 50

95 1450' INNERDUCT1-1.25" (PPA) 845C

Bore truck parked for boring. Signs in place for traffic control. Flaggers available if needed

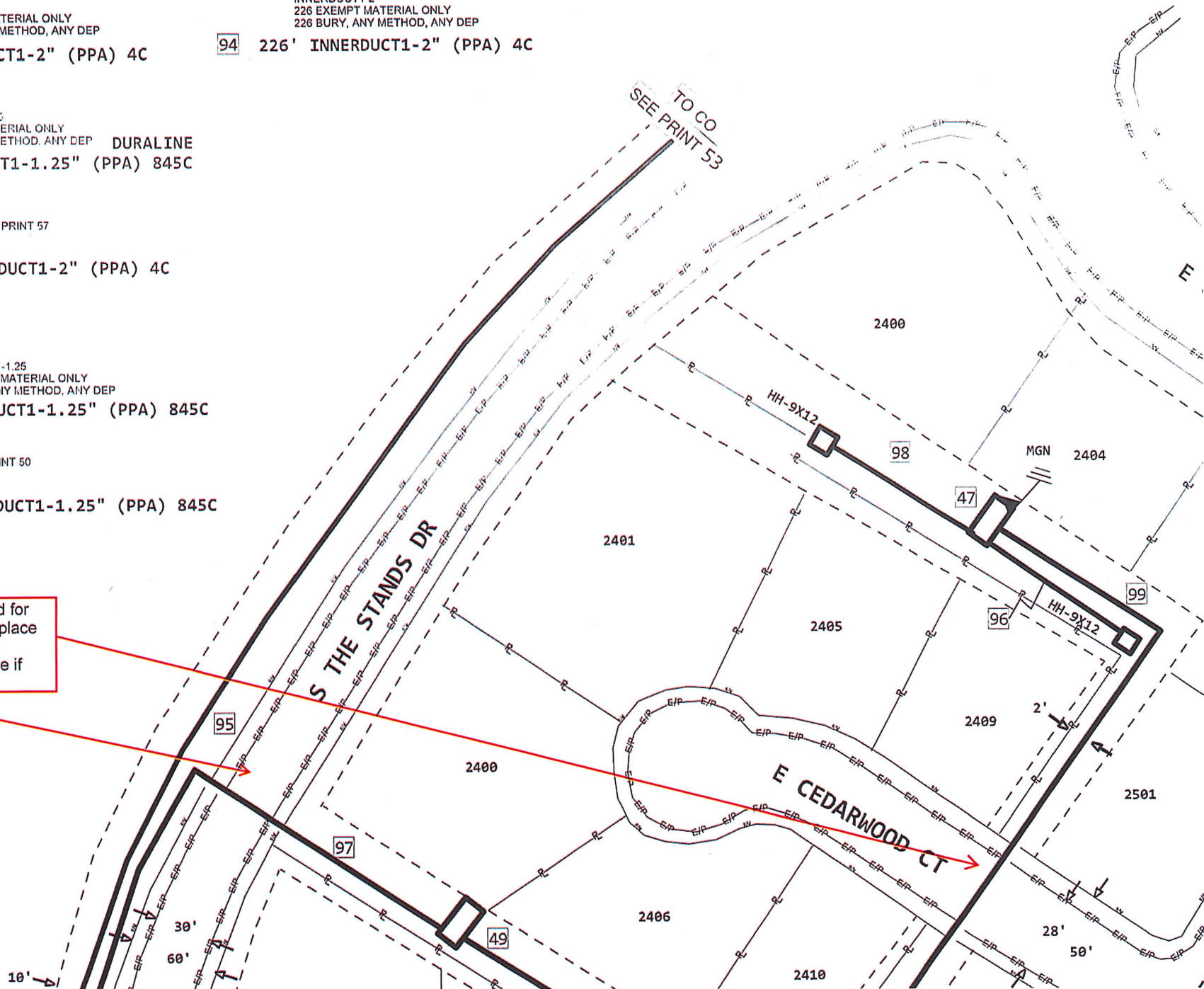

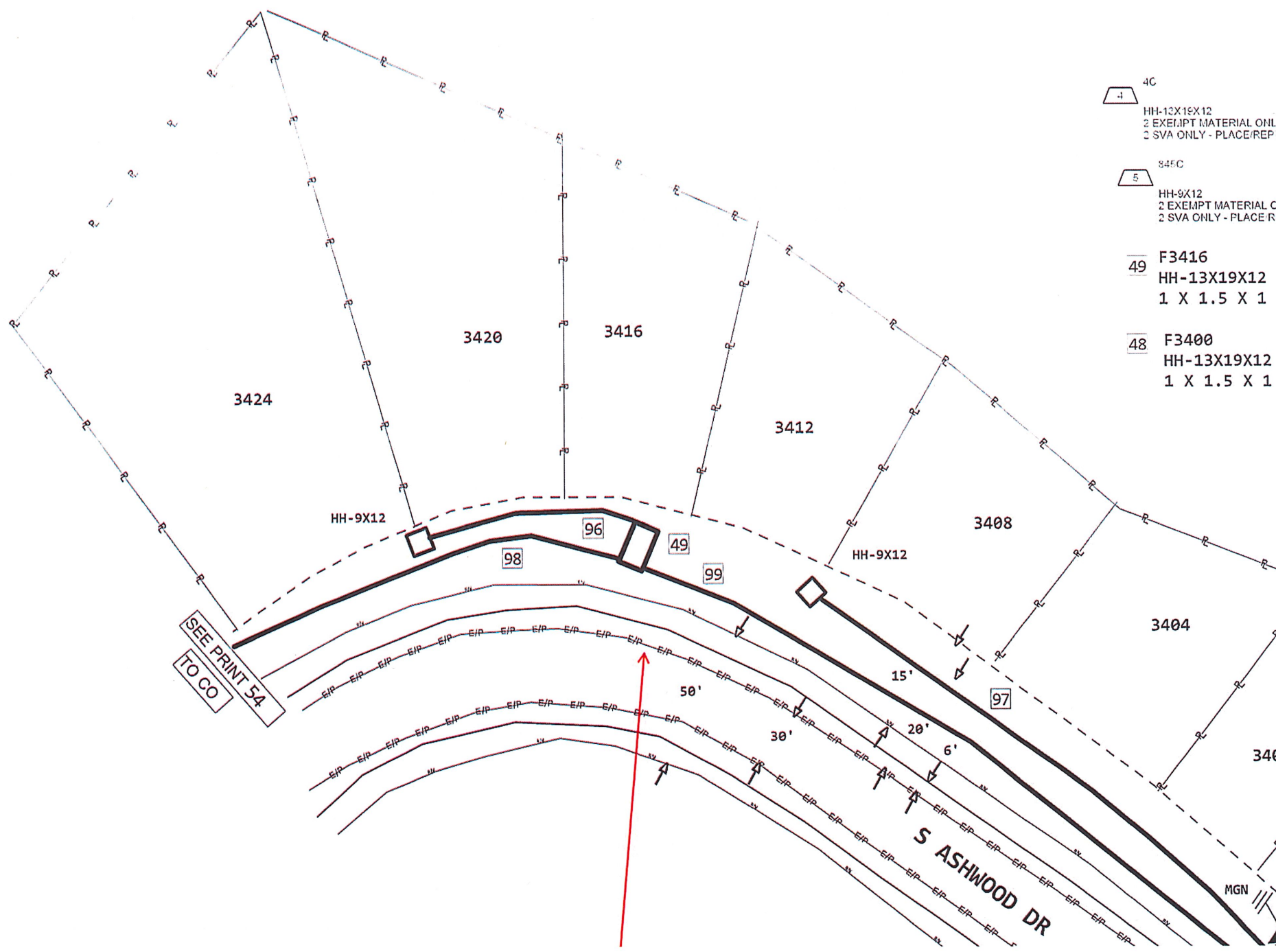

4C
 HH-13X19X12
 2 EXEMPT MATERIAL ONL
 2 SVA ONLY - PLACE/REP

845C
 5
 HH-9X12
 2 EXEMPT MATERIAL C
 2 SVA ONLY - PLACE R

49 F3416
 HH-13X19X12
 1 X 1.5 X 1

48 F3400
 HH-13X19X12
 1 X 1.5 X 1

SEE PRINT 54
 TO GO

S ASHWOOD DR

MGN

49 R2300
HH-13)
1 X 1.

4C
HH-13X19X
1 EXEMPT
1 SVA ONL

945C
HH-9X12
1 EXEMPT
1 SVA ONL

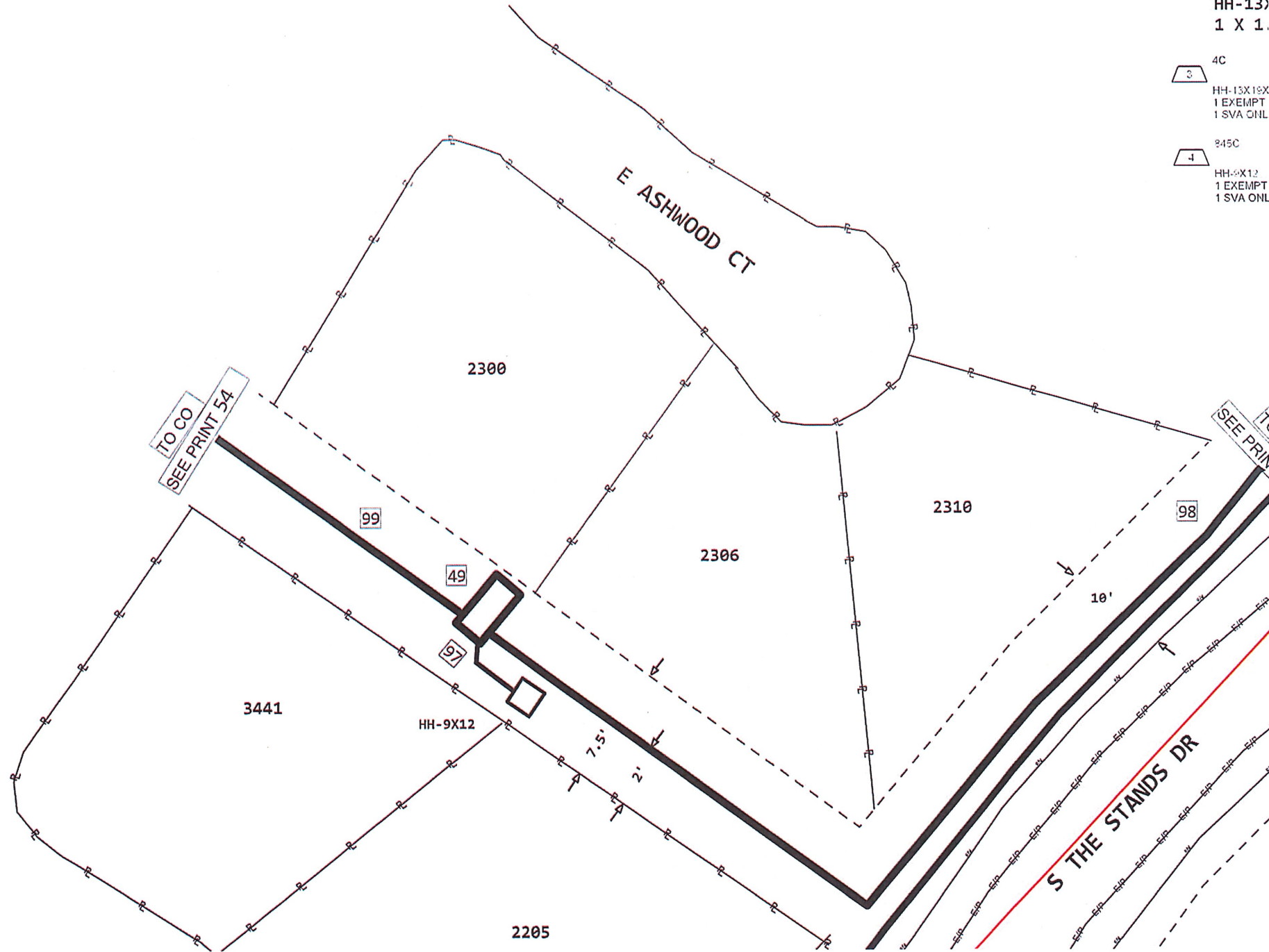

TO CO
SEE PRINT 54

SEE PRINT 54

S THE STANDS DR

49 F 3428
HH-13X19X12 (PPA) 4C
1 X 1.5 X 1= 1.5

48 F 3440
HH-13X19X12 (PPA) 4C
1 X 1.5 X 1= 1.5

4C
6
HH-13X19X12
2 EXEMPT MATERIAL ONLY
2 SVA ONLY - PLACE/REPLACE

845C
7
HH-9X12
2 EXEMPT MATERIAL ONLY
2 SVA ONLY - PLACE/REPLACE

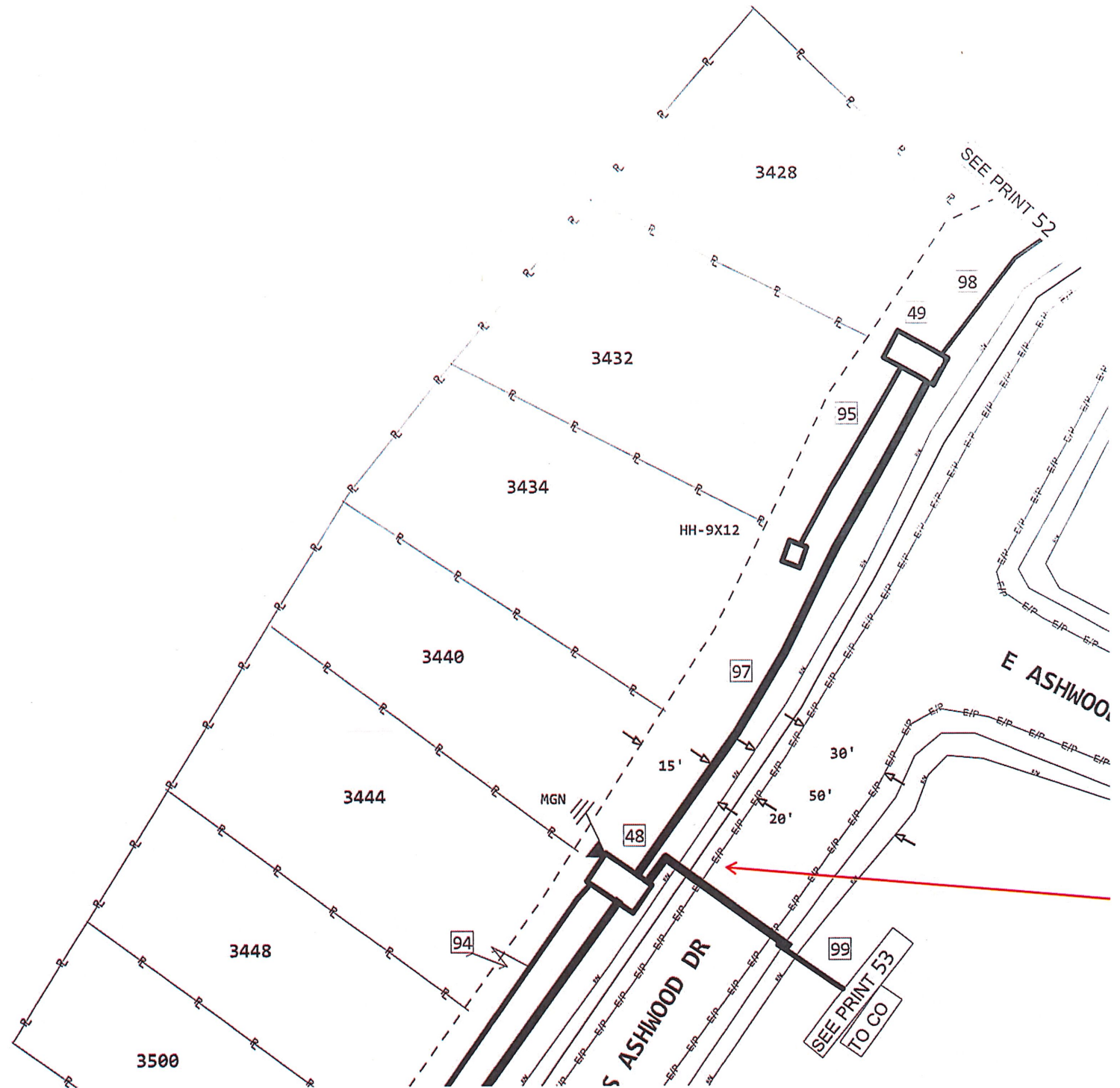

49 F3504
HH-13X19X12 (PPA) 4C
1 X 1.5 X 1 = 1.5

48 F2002
HH-13X19X12 (PPA) 4C
1 X 1.5 X 1 = 1.5

4C
5
HH-13X19X12
2 EXEMPT MATERIAL ONLY
2 SVA ONLY - PLACE/REPLACE

845C
6
HH-9X12
2 EXEMPT MATERIAL ONLY
2 SVA ONLY - PLACE/REPLACE

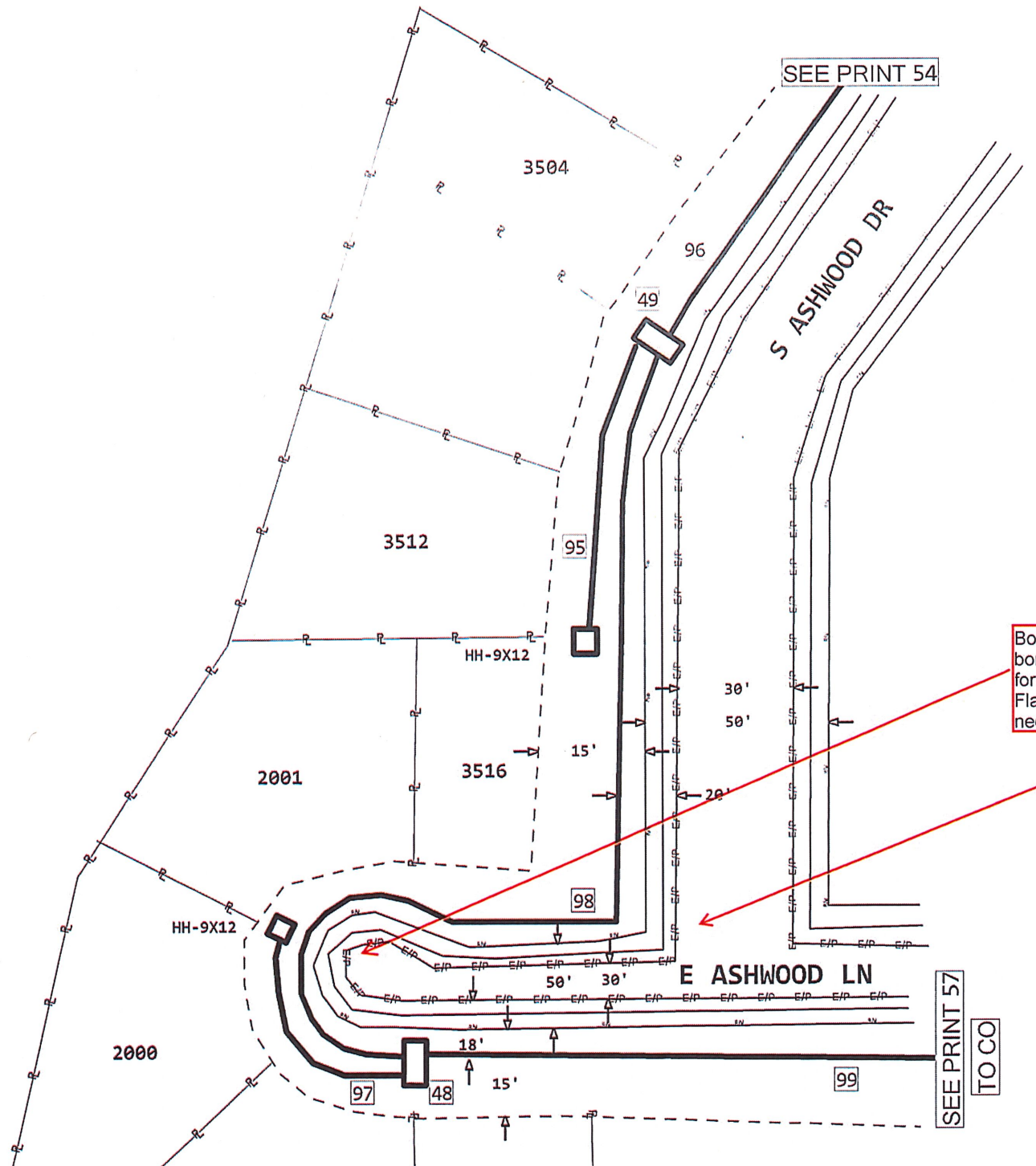

Bore truck boring. Sign for traffic co. Flaggers av needed

SEE PRINT 57
TO CO

49 F2210
HH-13X19X12 (PPA) 4C
1 X 1.5 X 1 = 1.5

48 F3509
HH-13X19X12 (PPA) 4C
1 X 1.5 X 1 = 1.5

4C
HH-13X19X12
2 EXEMPT MATERIAL ONLY
2 SVA ONLY - PLACE/REPLACE

845C
5
HH-9X12
2 EXEMPT MATERIAL ONLY
2 SVA ONLY - PLACE/REPLACE

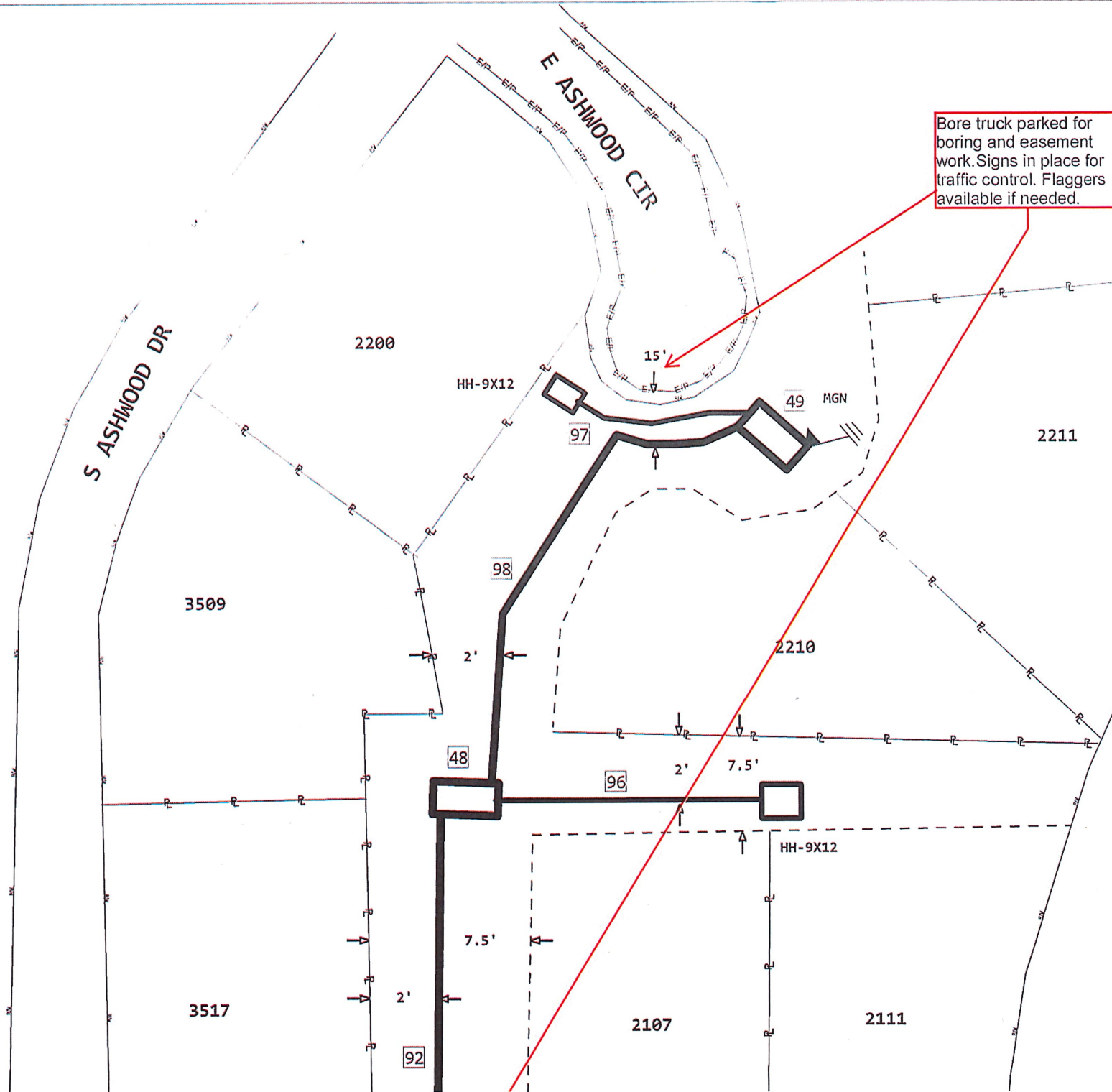

Bore truck parked for boring and easement work. Signs in place for traffic control. Flaggers available if needed.

49 F2416
HH-13X19X12 (PPA) 4C
1 X 1.5 X 1 = 1.5

48 R2500
HH-13X19X12 (PPA) 4C
1 X 1.5 X 1 = 1.5

4C
5
HH-13X19X12
2 EXEMPT MATERIAL ONLY
2 SVA ONLY - PLACE/REPLACE

845C
6
HH-9X12
3 EXEMPT MATERIAL ONLY
3 SVA ONLY - PLACE/REPLACE

Bore truck parked for boring and easement work. Signs in place for traffic control. Flaggers available if needed

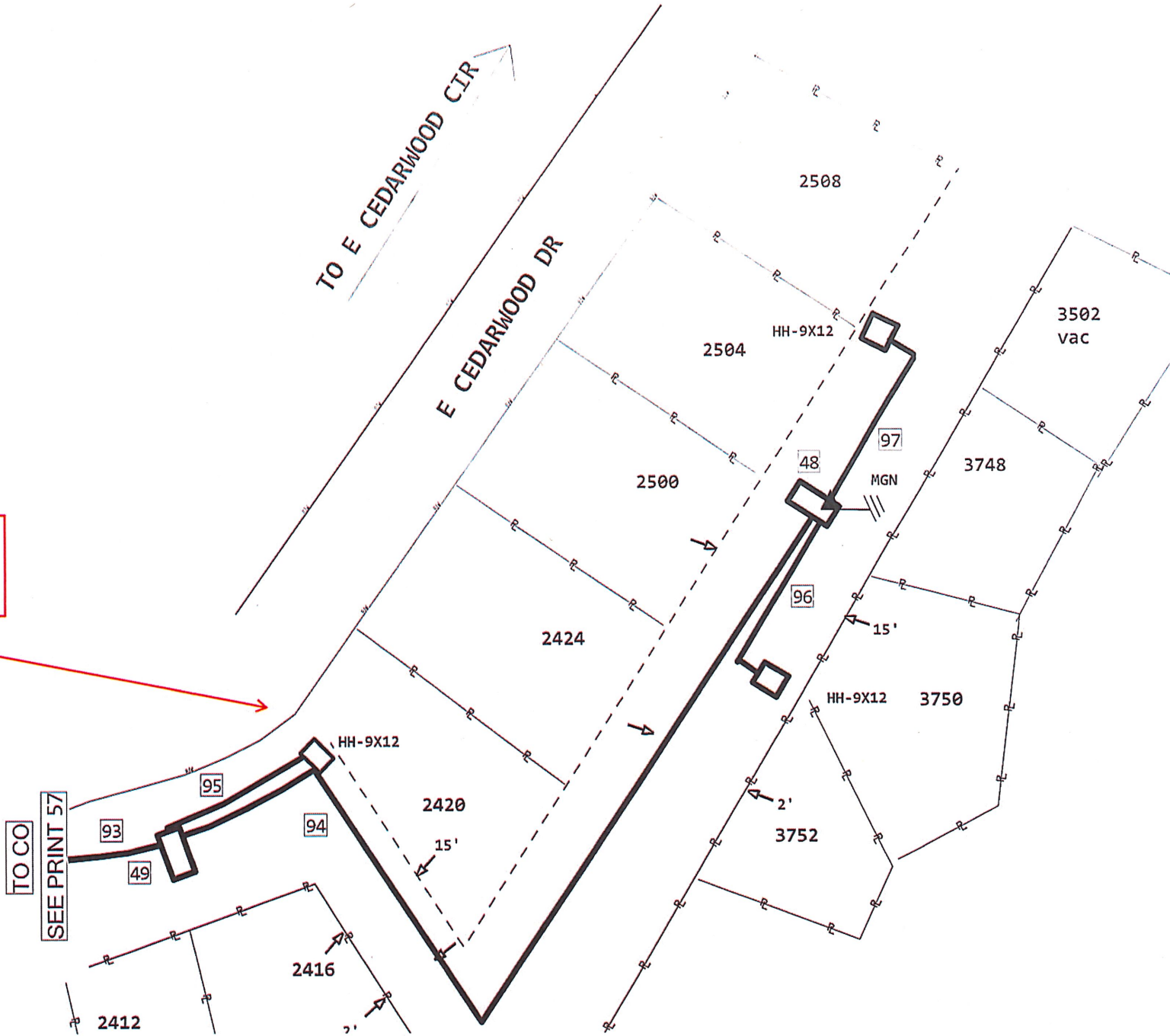

Bore truck parked for boring. Signs in place for traffic control. Flaggers available if needed

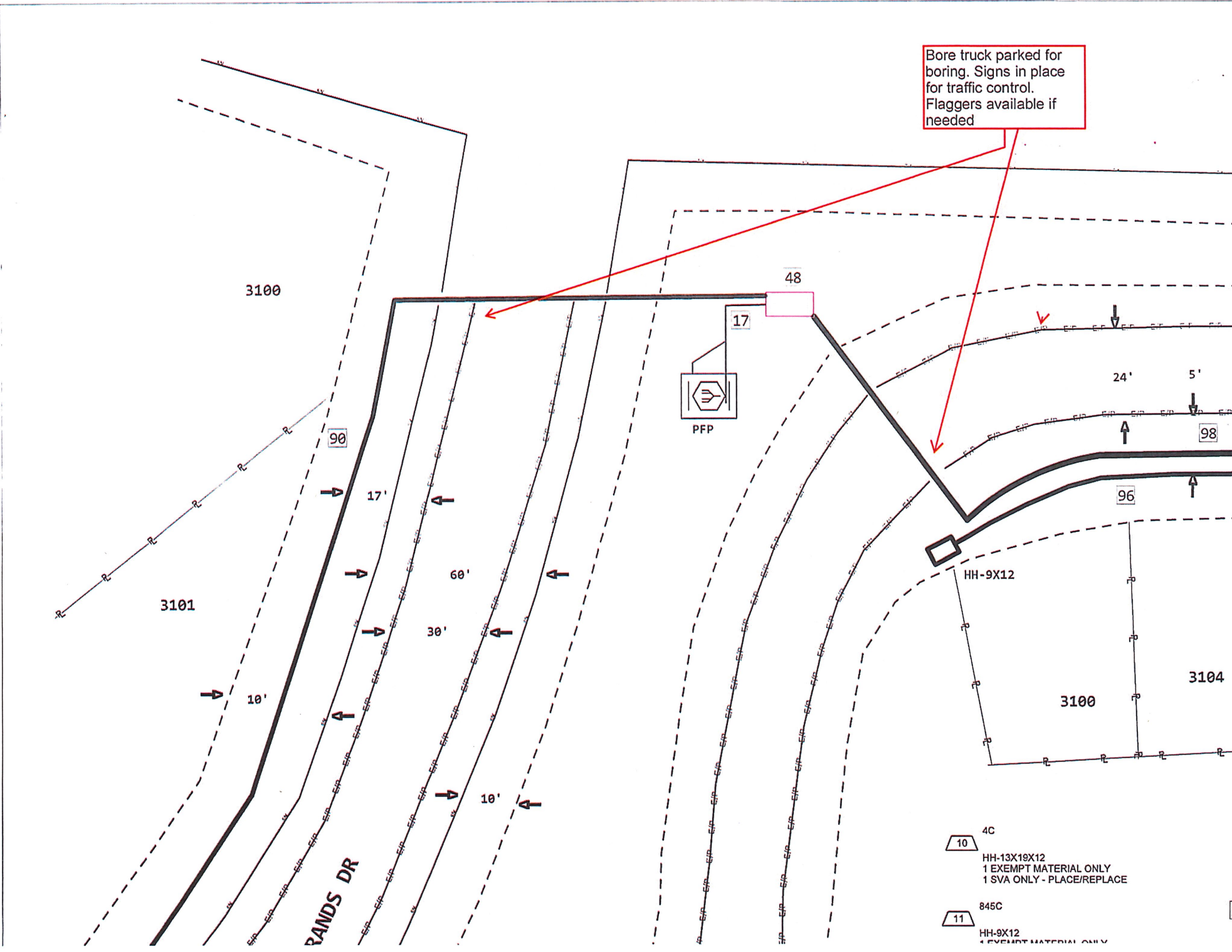

- 4C
 (10) HH-13X19X12
 1 EXEMPT MATERIAL ONLY
 1 SVA ONLY - PLACE/REPLACE
- 845C
 (11) HH-9X12
 1 EXEMPT MATERIAL ONLY

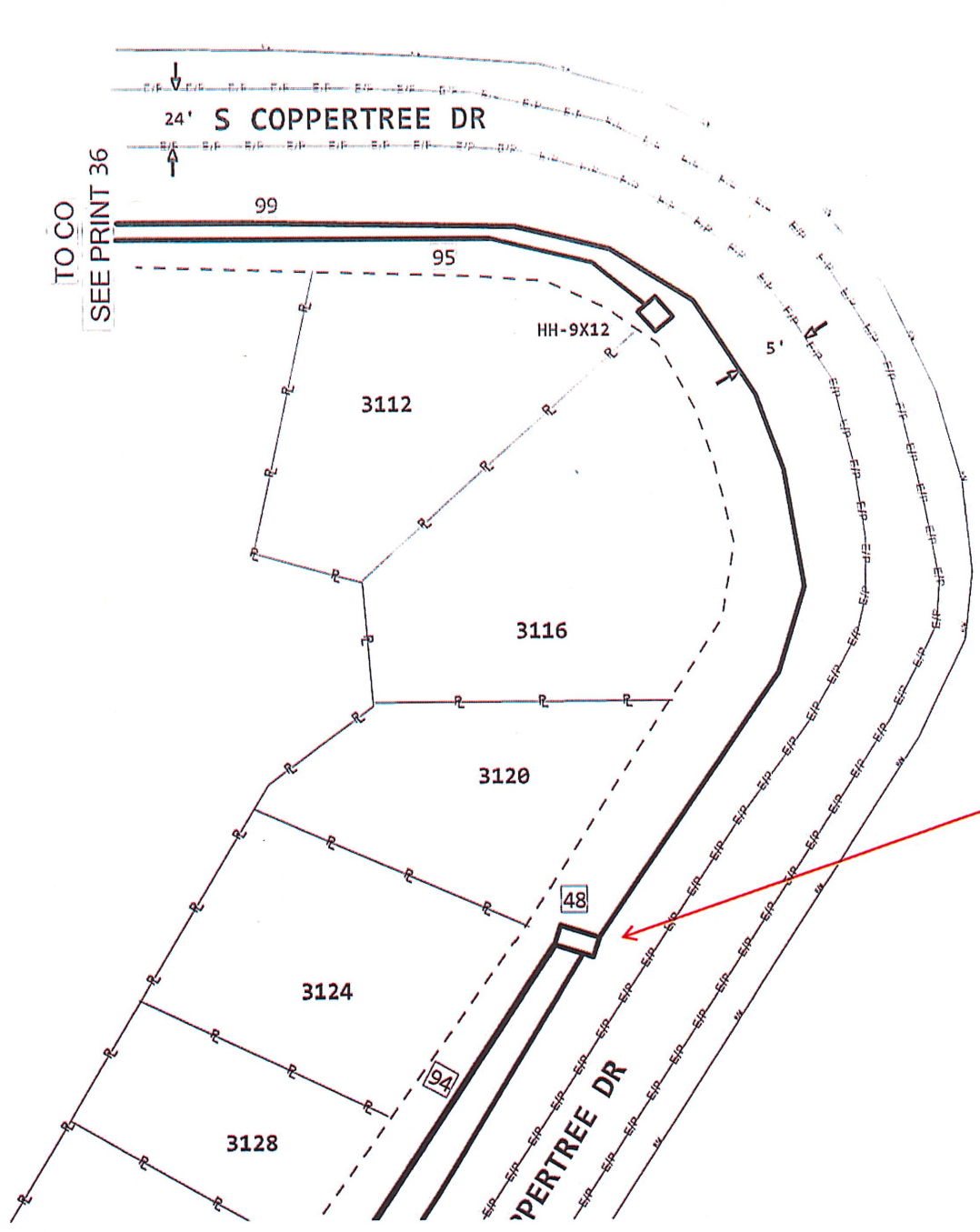

48 F3120
 HH-13X19X12 (PPA) 4C
 1 X 1.5 X 1 = 1.5

4C
 6 HH-13X19X12
 1 EXEMPT MATERIAL ONLY
 1 SVA ONLY - PLACE/REPLACE

845C
 7 HH-9X12
 2 EXEMPT MATERIAL ONLY
 2 SVA ONLY - PLACE/REPLACE

Bore tr
 boring.
 for traf
 Flagge
 needed

CABLE BEING PLAC
 RUN CONDUIT.

49 F3148
HH-13X19X12 (PPA) 4C
1 X 1.5 X 1 = 1.5

48 F3153
HH-13X19X12 (PPA) 4C
1 X 1.5 X 1 = 1.5

47 F3169
HH-13X19X12 (PPA) 4C
1 X 1.5 X 1 = 1.5

9
4C
HH-13X19X12
3 EXEMPT MATERIAL ONLY
3 SVA ONLY - PLACE/REPLACE

10
845C
HH-9X12
4 EXEMPT MATERIAL ONLY
4 SVA ONLY - PLACE/REPLACE

Bore truck parked for boring. Signs in place for traffic control. Flaggers available if needed

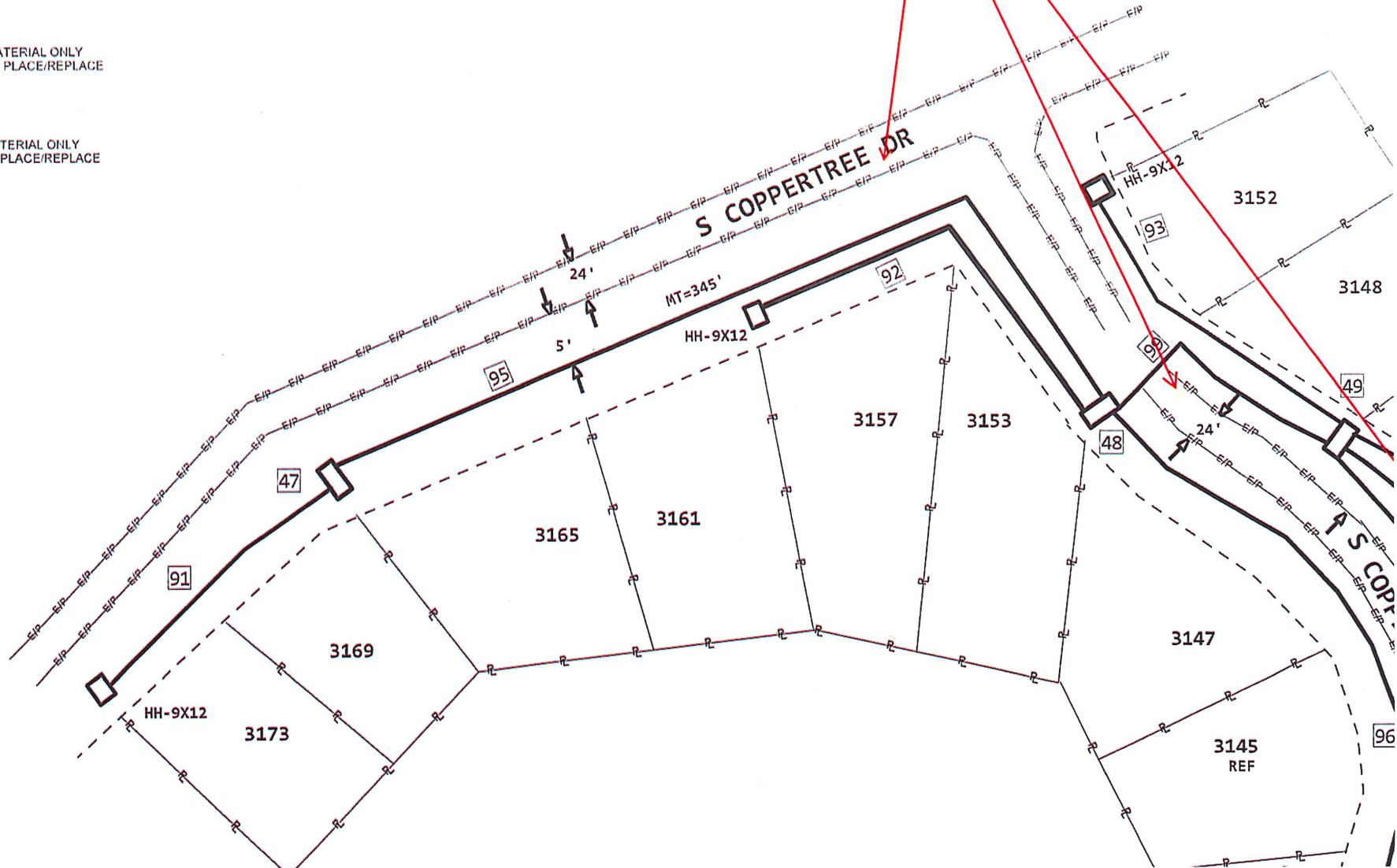

49 F3145
HH-13X19X12 (PPA) 4C
1 X 1.5 X 1 = 1.5

45 F3221
HH-13X19X12 (PPA) 4C
1 X 1.5 X 1 = 1.5

48 F3216
HH-13X19X12 (PPA) 4C
1 X 1.5 X 1 = 1.5

4C
10
HH-13X19X12
5 EXEMPT MATERIAL ONLY
5 SVA ONLY - PLACE/REPLACE

47 F3238
HH-13X19X12 (PPA) 4C
1 X 1.5 X 1 = 1.5

845C
11
HH-9X12
6 EXEMPT MATERIAL ONLY
6 SVA ONLY - PLACE/REPLACE

46 F3205
HH-13X19X12 (PPA) 4C
1 X 1.5 X 1 = 1.5

845C
7
INNERDUCT1-1.25
130 EXEMPT MATERIAL ONLY
130 BURY, ANY METHOD, ANY DEP

91 130' INNERDUCT1-1.25" (PPA) 845C
845C
8
INNERDUCT1-1.25
214 EXEMPT MATERIAL ONLY
214 BURY, ANY METHOD, ANY DEP

90 214' INNERDUCT1-1.25" (PPA) 845C
845C
9
INNERDUCT1-1.25
160 EXEMPT MATERIAL ONLY
160 BURY, ANY METHOD, ANY DEP

89 160' INNERDUCT1-1.25" (PPA) 845C DURALINE

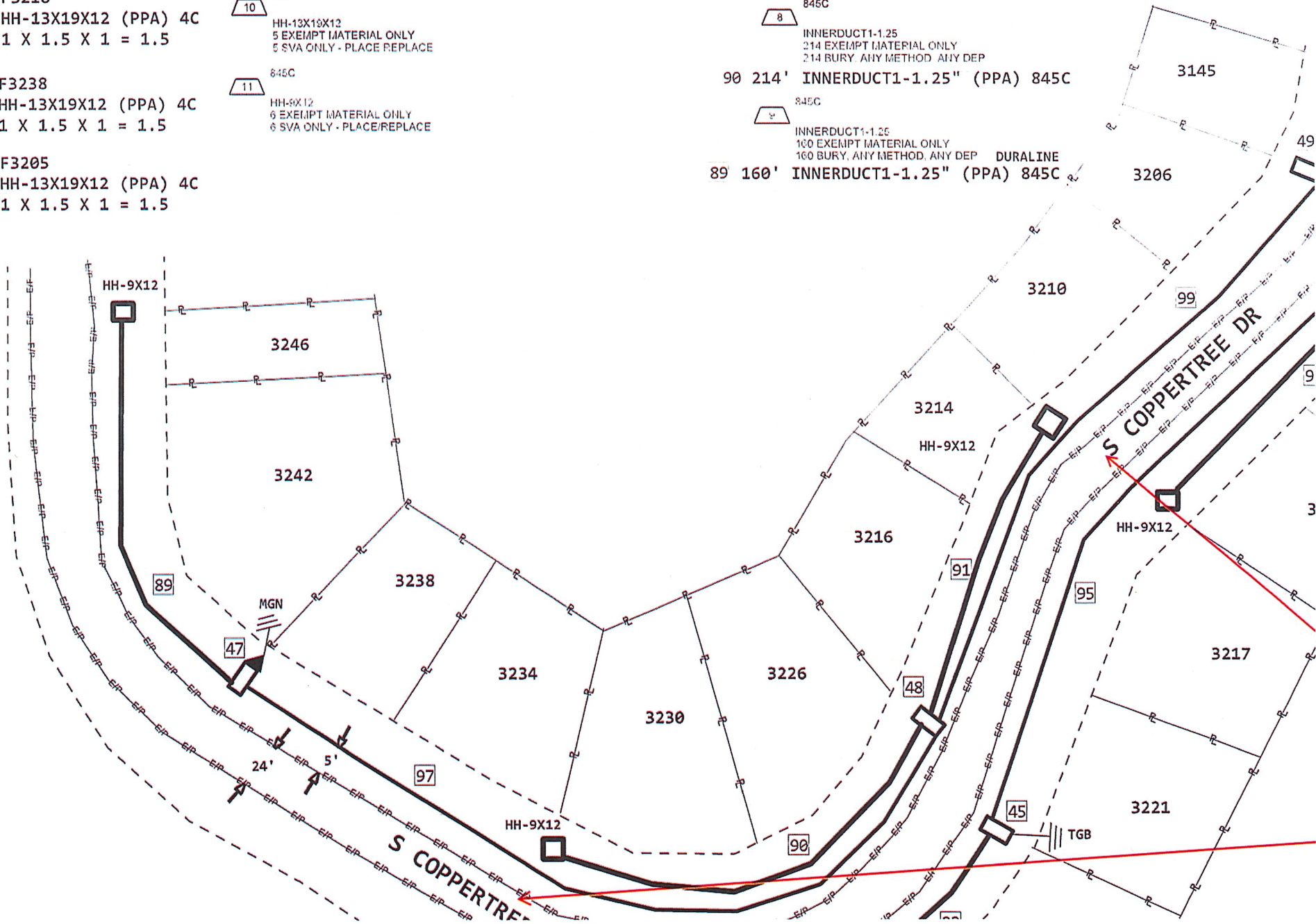

TO CO
SEE PRINT 41

6 4C

INNERDUCT1-2"
274 EXEMPT MATERIAL ONLY
274 BURY, ANY METHOD, ANY DEP

91 274' INNERDUCT1-2" (PPA) 4C

7 4C

INNERDUCT1-2"
358 EXEMPT MATERIAL ONL
358 BURY, ANY METHOD, AN

89 358' INNERDUCT1-2" (

12 845C

INNERDUCT1-1.25
274 EXEMPT MATERIAL ONLY
274 BURY, ANY METHOD, ANY DEP

90 274' INNERDUCT1-1.25" (PPA) 845C

9 845C

INNERDUCT1-1.25
96 EXEMPT MATERIAL ONLY
96 BURY, ANY METHOD, ANY

88 96' INNERDUCT1-1.25"

10 845C

INNERDUCT1-1.25
74 EXEMPT MATERIAL ONLY
74 BURY, ANY METHOD, ANY

87 74' INNERDUCT1-1.25'

11 845C

INNERDUCT1-1.25
86 EXEMPT MATERIAL ONLY
86 BURY, ANY METHOD, ANY

86 86' INNERDUCT1-1.25'

16 4C

GRD-ROD
2 EXEMPT M
2 SVA ONLY

17 845C

CONT-F
10 EXEM
10 SVA

S THE STANDS DR

E OAKMONT DR

E OAKM

98

49

97

60'

30'

17'

94

10'

25'

2401

2405

2409

2411

2402

3300

24

30'

60'

93

92

46

87

7.5'

88

HH-9X12

HH-9X12

TGB

48

96

25'

2'

25'

SEE PRINT 45

89

89

88

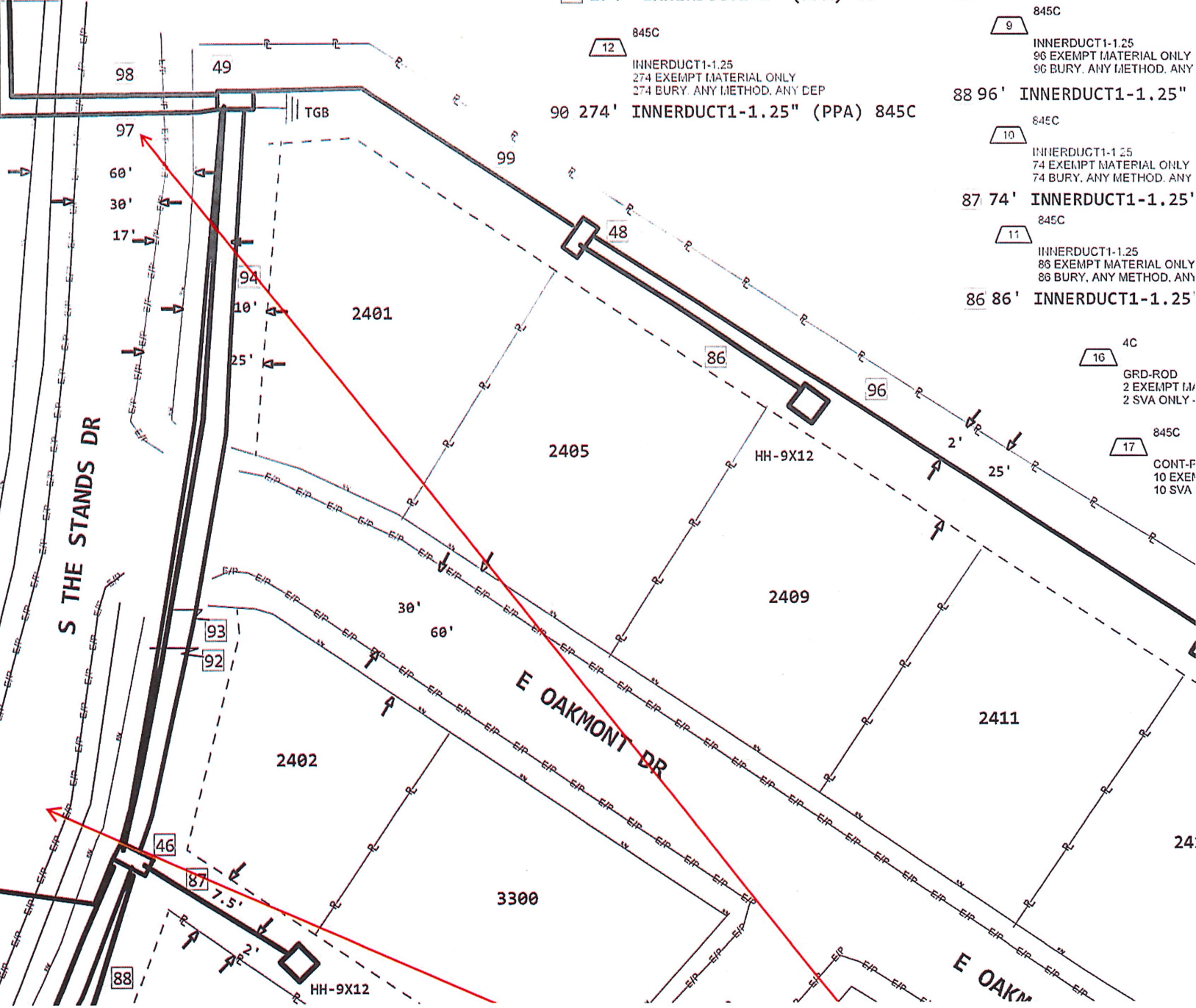

49 F3205
HH-13X19X12 (PPA) 4C
1 X 1.5 X 1 = 1.5

48 F3204
HH-13X19X12 (PPA) 4C
1 X 1.5 X 1 = 1.5

4C
HH-13X19X12
2 EXEMPT MATERIAL ONLY
2 SVA ONLY - PLACE/REPLACE

49
HH-9X12
3 EXEMPT MATERIAL ONLY
3 SVA ONLY - PLACE/REPLACE

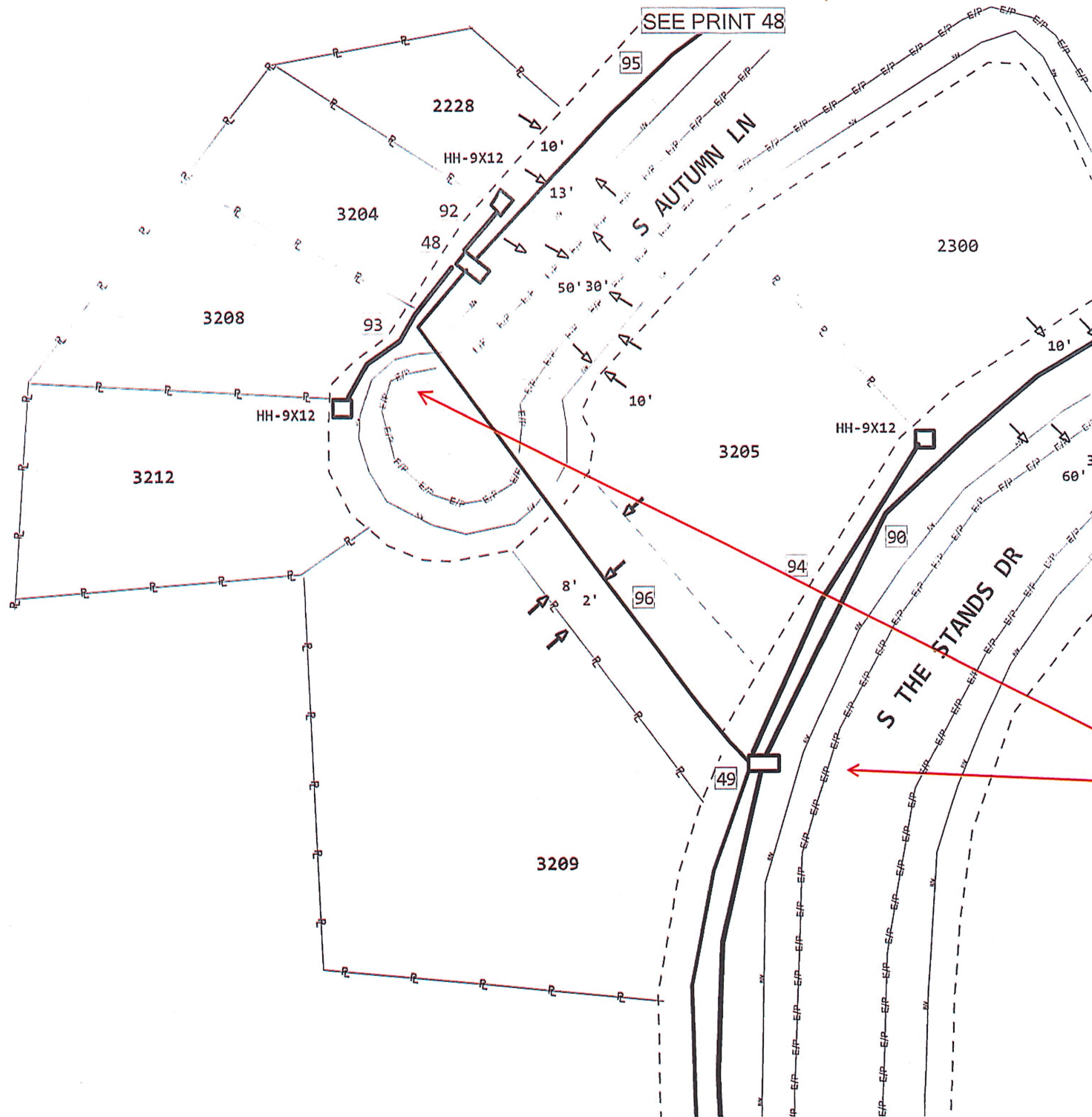

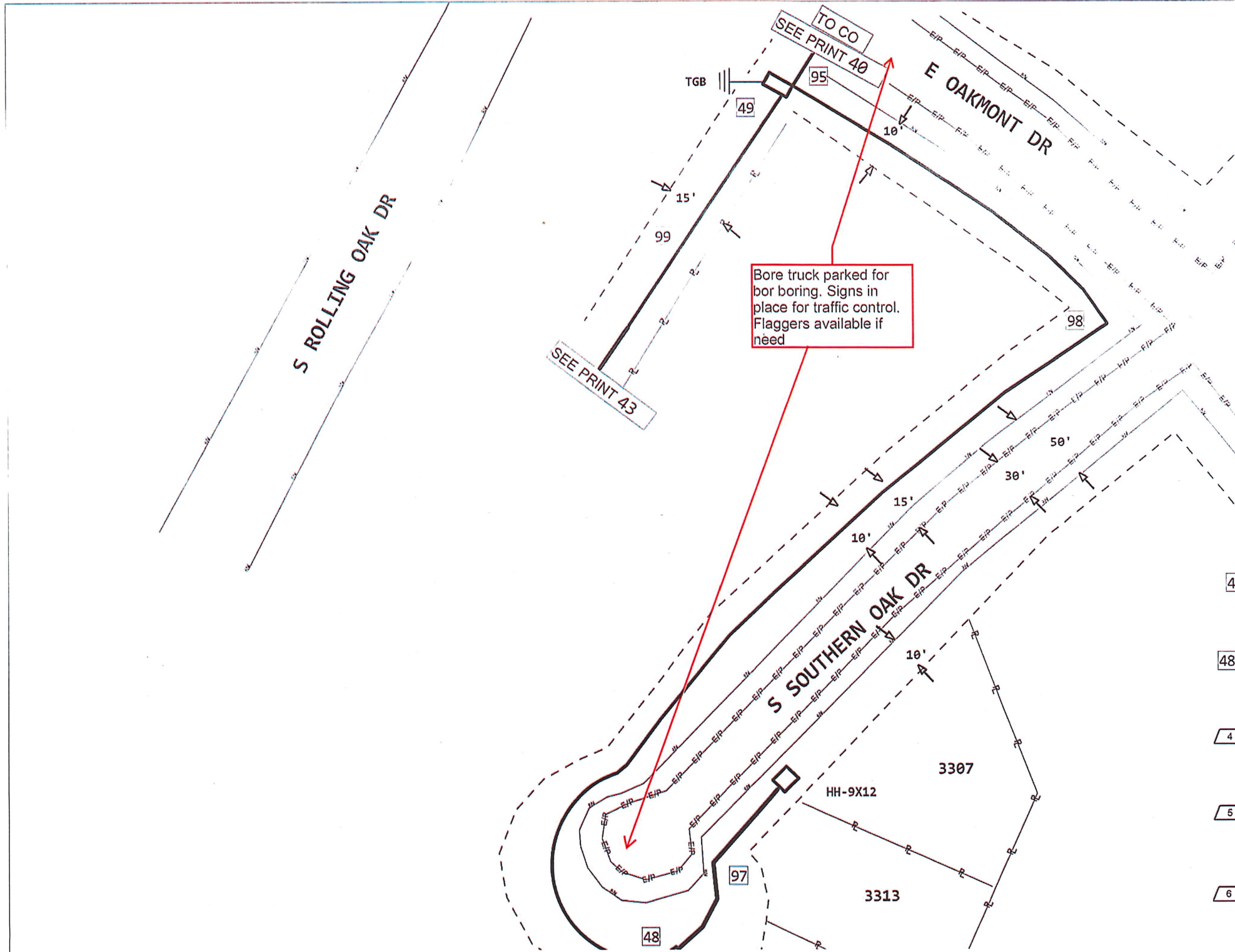

Bore truck parked for bor boring. Signs in place for traffic control. Flaggers available if need

S ROLLING OAK DR



- 4C
1
HH-13X19X12
3 EXEMPT MATERIAL
3 SVA ONLY - PLACE
- 845C
2
HH-9X12
3 EXEMPT MATEF
3 SVA ONLY - PL

845C
5
INNE
70 E
70 B

97 70'

845C
6
INNE
90 EX
90 BI

96 90'

845C
7
INNE
30 E
30 B

95 30'

845C
4

INNERDUCT1-1.25
80 EXEMPT MATERIAL ONLY
80 BURY. ANY METHOD. ANY DEP DURALINE

93 80' INNERDUCT1-1.25" (PPA) 845C

S ASHWOOD DR

S THE STANDS DR

S ROLLING OAK DR

2401

3349

3345

3341

3333

3337

2405

2409

2501

94

98

99

3412

E CEDARWOOD C

HH-9X12

HH-9X12

HH-9X12

HH-9X12

93

95

48

99

15'

2'

15'

2'

TGB

TGB

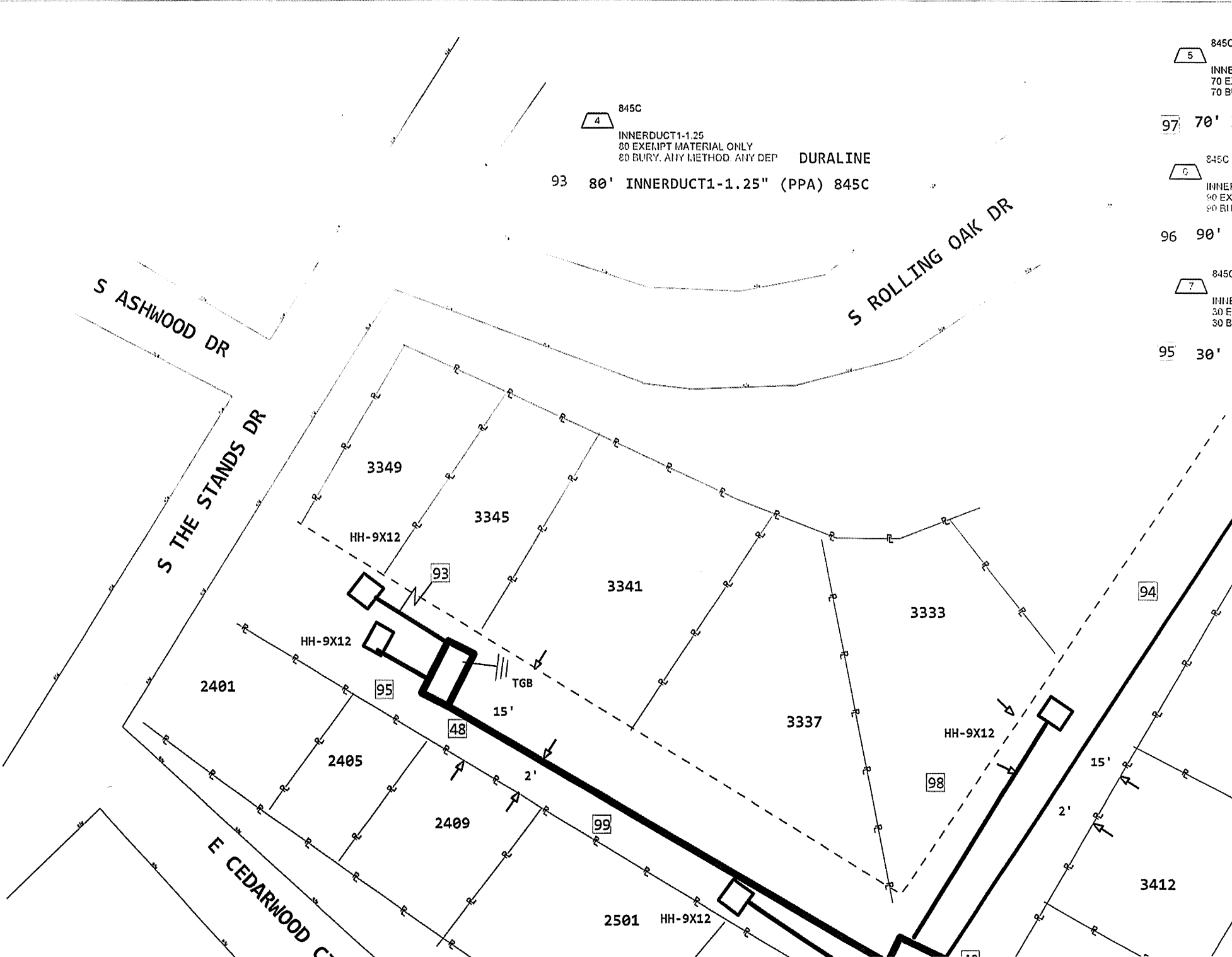

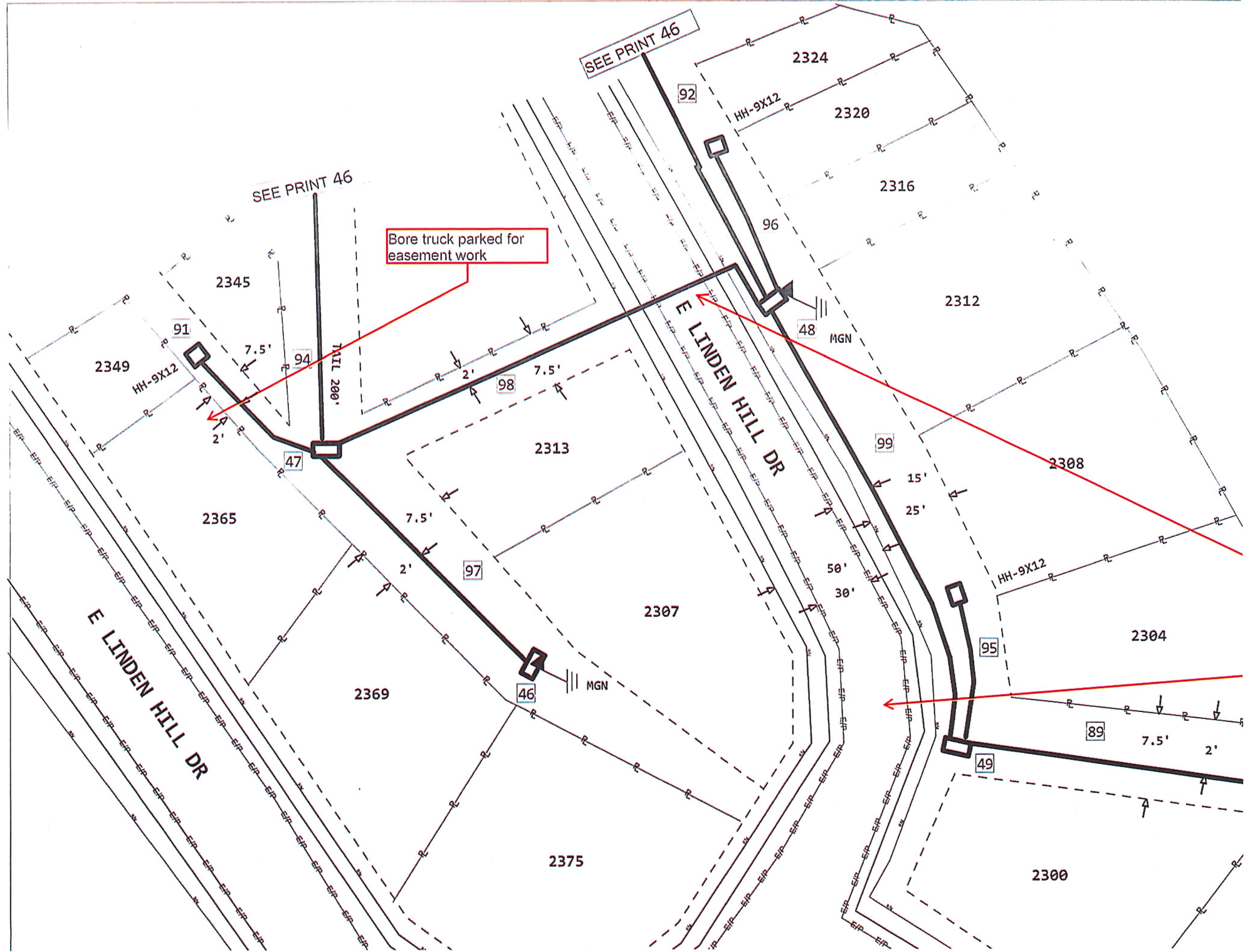

49 F2344
HH-13X19X12 (PPA) 4C
1 X 1.5 X 1 = 1.5

48 F2328
HH-13X19X12 (PPA) 4C
1 X 1.5 X 1 = 1.5

47 R2317
HH-13X19X12 (PPA) 4C
1 X 1.5 X 1 = 1.5

845C
2
HH-9X12
2 EXEMPT MATERIAL ONLY
2 SVA ONLY - PLACE/REPLACE
4C
1
HH-13X19X12
3 EXEMPT MATERIAL ONLY
3 SVA ONLY - PLACE/REPLACE

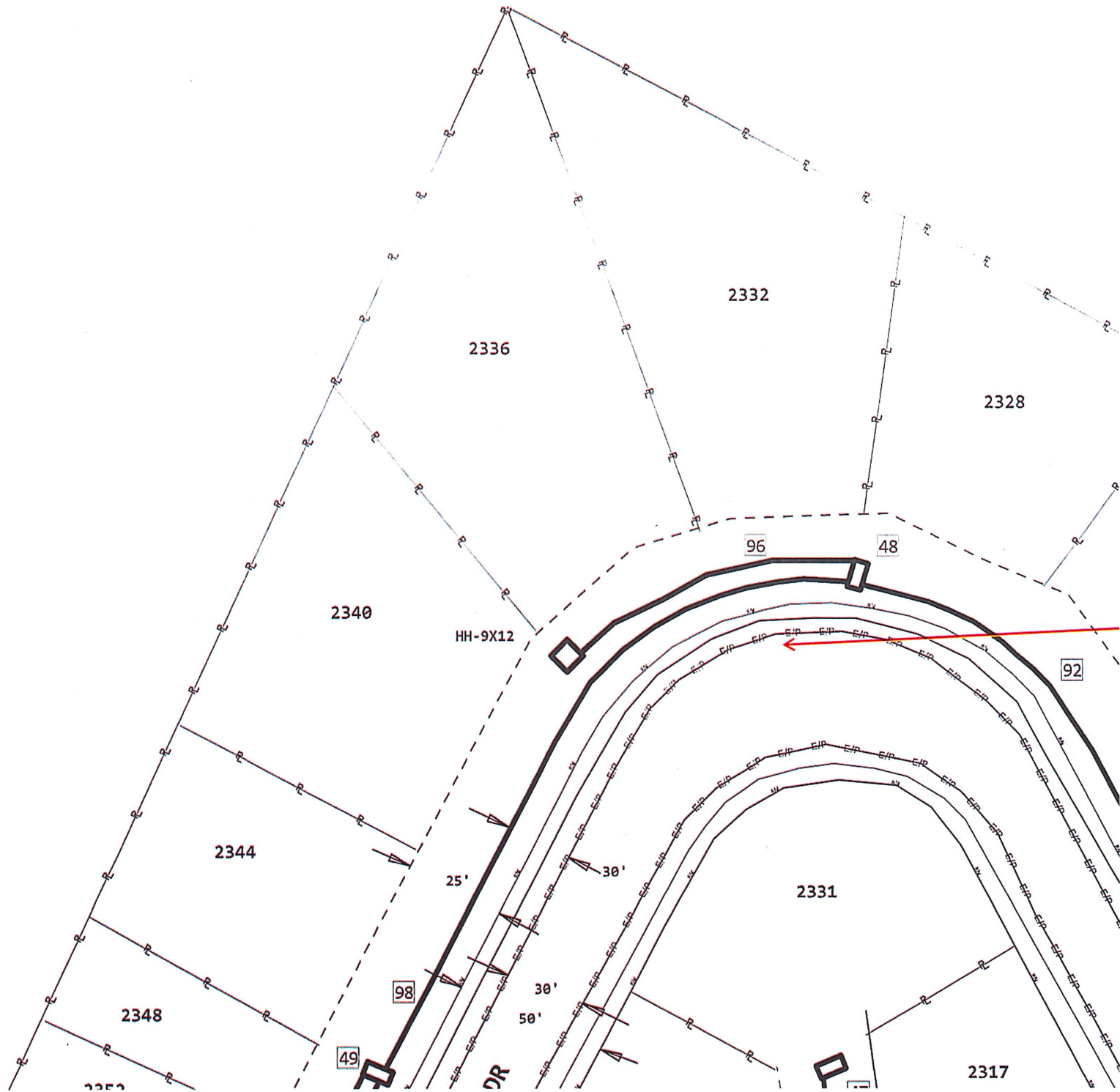

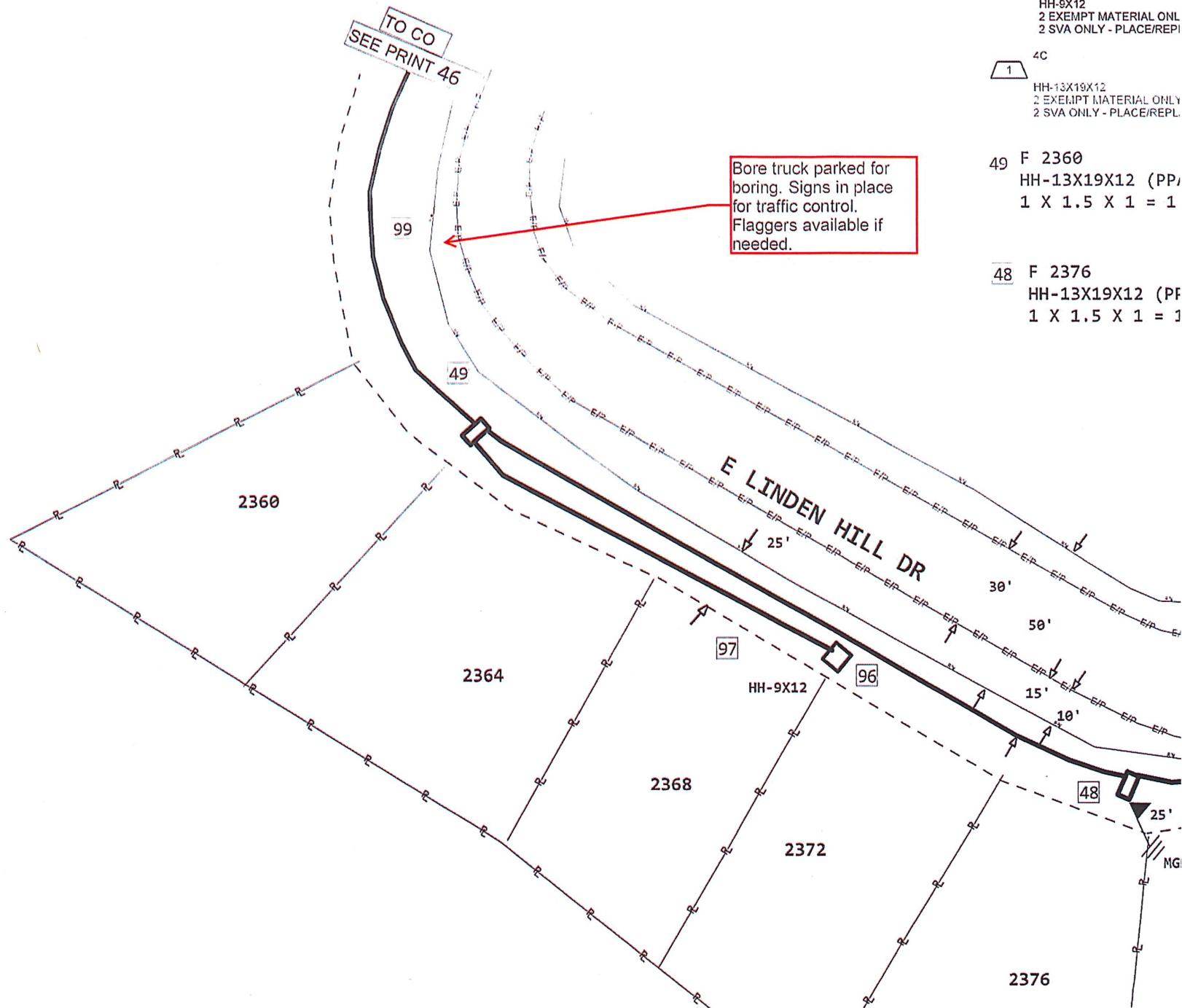

- 2 845C
 HH-9X12
 2 EXEMPT MATERIAL ONLY
 2 SVA ONLY - PLACE/REPL
- 1 4C
 HH-13X19X12
 2 EXEMPT MATERIAL ONLY
 2 SVA ONLY - PLACE/REPL

49 F 2360
 HH-13X19X12 (PP/
 1 X 1.5 X 1 = 1

48 F 2376
 HH-13X19X12 (PF
 1 X 1.5 X 1 = 1

Bore truck parked for boring. Signs in place for traffic control. Flaggers available if needed.

TO CO
 SEE PRINT 46

E LINDEN HILL DR

2360

2364

2368

2372

2376

99

49

97

HH-9X12

96

48

NGI

25'

30'

50'

15'

10'

25'

1 4C
 HH-13X19X12
 3 EXEMPT MATERIAL ONLY
 3 SVA ONLY - PLACE/REPLACE

2 845C
 HH-9X12
 4 EXEMPT MATERIAL ONLY
 4 SVA ONLY - PLACE/REPLACE

49 F2225
 HH-13X19X12 (PPA) 4C
 1 X 1.5 X 1 = 1.5

48 F2233
 HH-13X19X12 (PPA) 4C
 1 X 1.5 X 1 = 1.5

47 F3101
 HH-13X19X12 (PPA) 4C
 1 X 1.5 X 1 = 1.5

7 845C
 INNERDUCT1-1.25
 40 EXEMPT MATERIAL ONLY
 40 BURY, ANY METHOD, ANY DEP

92 40' INNERDUCT1-1.25" (PI

9 845C
 INNERDUCT1-1.25
 88 EXEMPT MATERIAL ONLY
 88 BURY, ANY METHOD, ANY DEF

93 88' INNERDUCT1-1.25" (

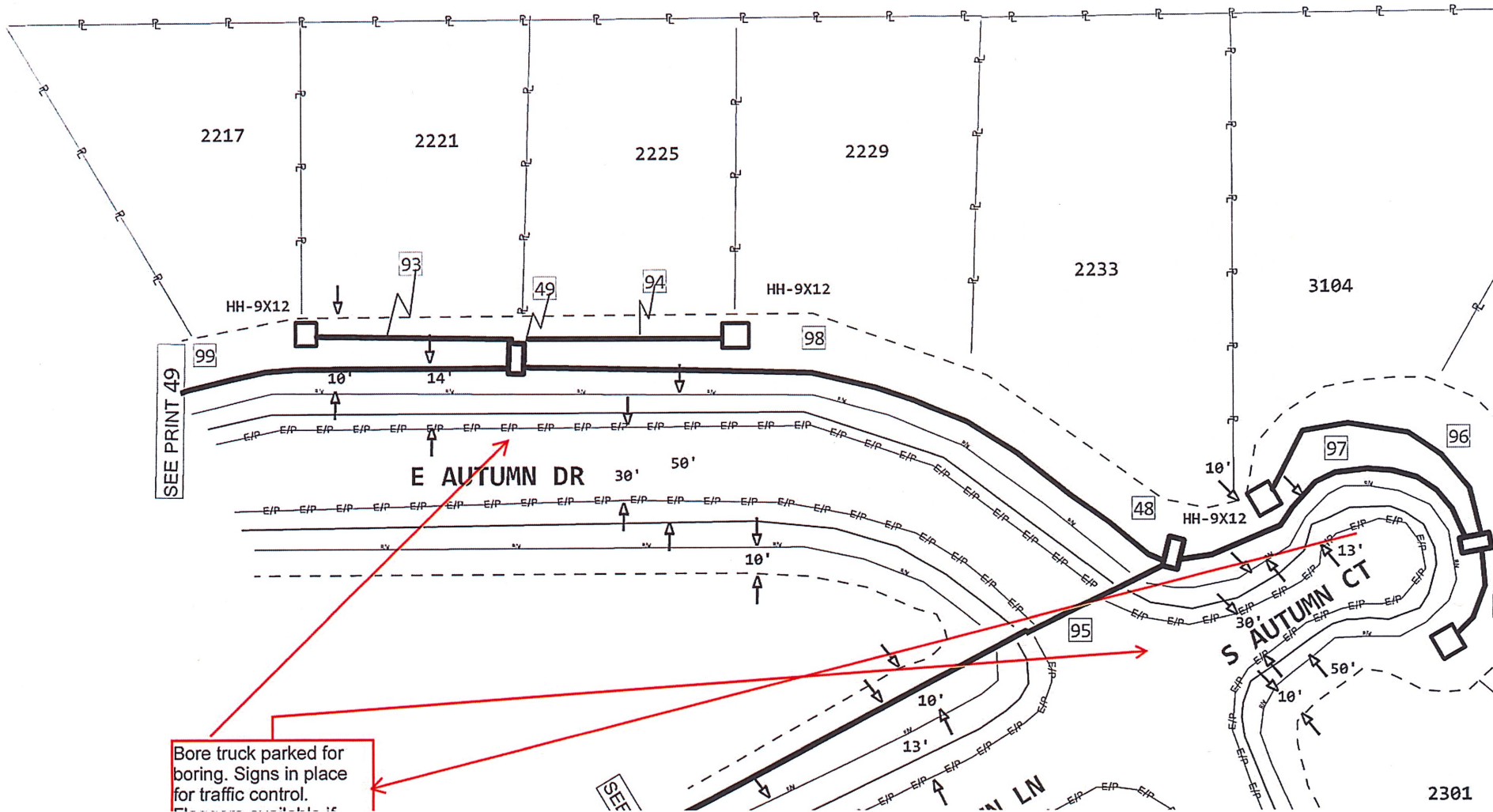

1 4C
HH-13X19X12
2 EXEMPT MATERIAL ONLY
2 SVA ONLY - PLACE/REPLACE

2 845C
HH-9X12
3 EXEMPT MATERIAL ONLY
3 SVA ONLY - PLACE/REPLACE

49 F2209
HH-13X19X12 (PPA) 4C
1 X 1.5 X 1 = 1.5

48 F2208
HH-13X19X12 (PPA) 4C
1 X 1.5 X 1 = 1.5

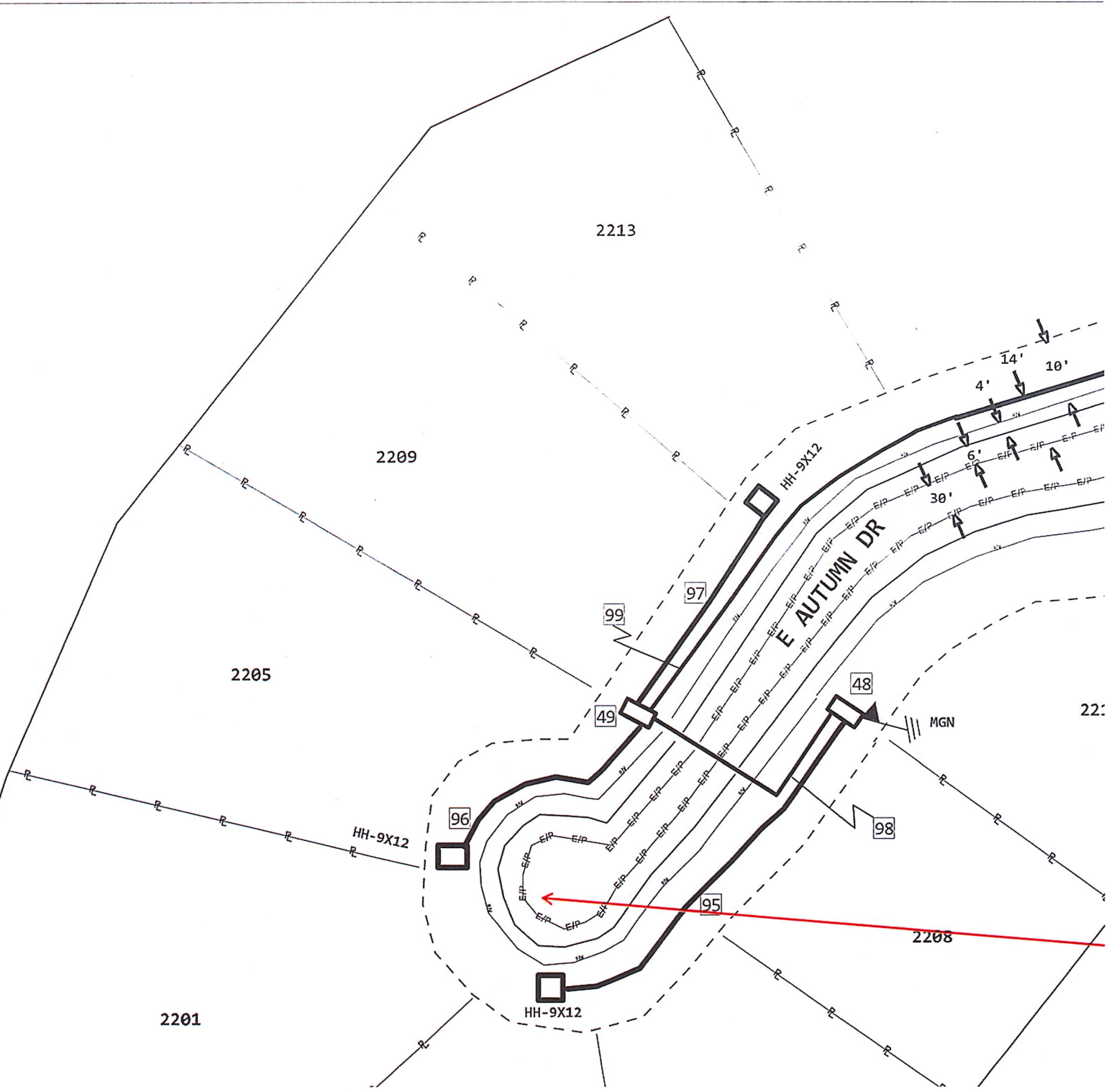

2201

2205

2209

2213

2214

2208

HH-9X12

HH-9X12

HH-9X12

E AUTUMN DR

MGN

96

99

97

98

95

4C

1

2

49

48

14'

10'

4'

6'

30'

TO CO
SEE PRINT 40

E OAKMONT DR

E LINDEN HILL DR

S THE STANDS DR

49 F3313
HH-13X19X12 (PPA) 4C
1 X 1.5 X 1 = 1.5

49 F3320
HH-13X19X12 (PPA) 4C
1 X 1.5 X 1 = 1.5

4C
5
HH-13X19X12
2 EXEMPT MATERIAL ONLY
2 SVA ONLY - PLACE/REPLACE

845C
6
HH-9X12
1 EXEMPT MATERIAL ONLY
1 SVA ONLY - PLACE/REPLACE

3312

3316

3320

3324

90

91

49

96

98

49

94

95

MGN

Bore truck
boring. Si
for traffic
Flaggers
needed

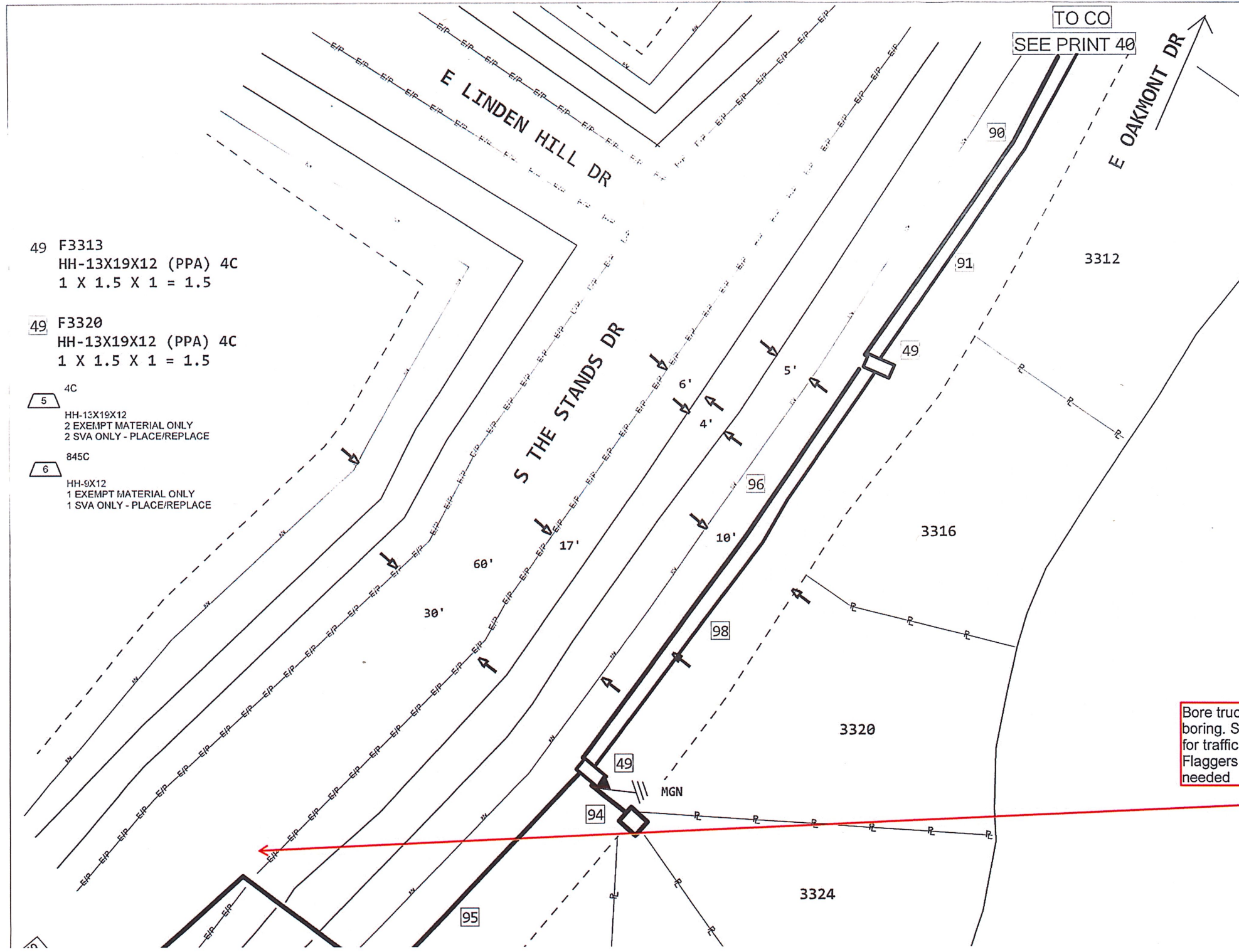

4C
 3
 HH-13X19X12
 2 EXEMPT MATERIAL ONLY
 2 SVA ONLY - PLACE/REPLACE

49 R3405
 HH-13X19X12 (PPA) 4C
 1 X 1.5 X 1 = 1.5

48 R3429
 HH-13X19X12 (PPA) 4C
 1 X 1.5 X 1 = 1.5

4C
 5
 GRD-ROD
 2 EXEMPT MATERIAL ONLY
 2 SVA ONLY - FURNISH AND PL

845C
 6
 CONT-PL-CABLE
 10 EXEMPT MATERIAL ONLY
 10 SVA ONLY - HAND DIG AND P

Bore truck parked for boring and easement work. Signs in place for traffic control. Flaggers available if needed

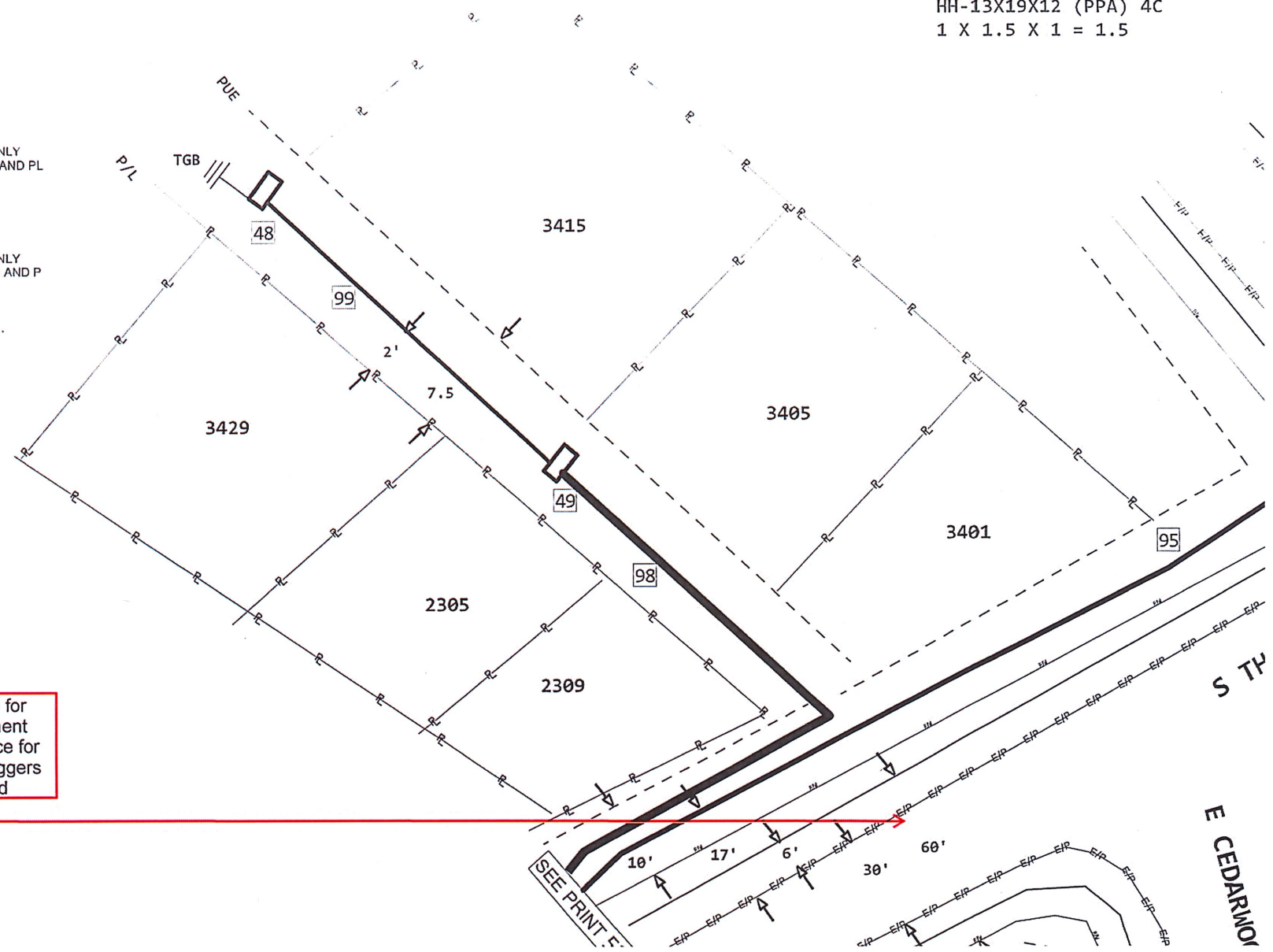

SEE PRINT E

S TH
 E CEDAR

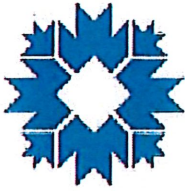

CITY OF BLOOMINGTON

RIGHT-OF-WAY USE PERMIT APPLICATION

401 N Morton Street, Suite 130
P.O. Box 100
Bloomington, IN 47402

Phone: (812) 349-3913
Fax: (812) 349-3520
Email: engineering@bloomington.in.gov

ROW EXCAVATION ROW USE
ADDRESS OF ROW ACTIVITY: _____

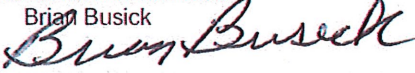
A. APPLICANT/AGENT INFORMATION: APPLICANT NAME: <u>Brian Busick</u> E-MAIL: <u>bbusick@linealcontracting.com</u> COMPANY: <u>Lineal Contracting Inc.</u> ADDRESS: <u>2922 Mitchell Road</u> CITY, STATE, ZIP: <u>Bedford In. 47421</u> 24-HR EMERGENCY CONTACT NAME: <u>Brian Busick</u> 24-HR CONTACT PHONE #: <u>812 - 521 - 3474</u> INSURANCE #*: <u>5000142821</u> COMPANY: <u>Thomburg</u> BOND #*: <u>69390442</u> COMPANY: <u>Western Surety</u> <small>* INSURANCE & BOND MUST BE ON FILE WITH THE CITY BEFORE PERMIT WILL BE ISSUED</small> **SUBCONTRACTOR INFORMATION** <small>(LIST ALL COMPANIES WORKING UNDER PRIMARY CONTRACTOR PERMIT)</small> COMPANY NAME: _____	D. TRAFFIC CONTROL DEVICES*: <input checked="" type="checkbox"/> CONES <input type="checkbox"/> ARROWBOARD <input type="checkbox"/> LIGHTED BARRELS <input type="checkbox"/> TYPE 3 BARRICADES <input checked="" type="checkbox"/> FLAGGERS <input type="checkbox"/> BPD OFFICER <small>*PROVIDING MUTCD COMPLIANT TEMPORARY TRAFFIC CONTROL DEVICES AND MAINTENANCE OF TRAFFIC (NOT) PLAN IS YOUR RESPONSIBILITY AND REQUIRED. See page 3 for additional MOT resources; the graph paper can be used for your MOT site plan if needed or you can submit a separate sheet</small>
B. WORK DESCRIPTION: <input type="checkbox"/> POD/DUMPSTER <input type="checkbox"/> CRANE <input type="checkbox"/> SCAFFOLDING <input type="checkbox"/> CONSTRUCTION USE* (EXPLAIN): <u>Aerial and Underground cable placement</u> <small>*EXCAVATION, LONG TERM USE FOR STORAGE OF MATERIAL/EQUIPMENT/WALKAROUND</small>	E. METERED PARKING SPACES NEEDED: <input type="checkbox"/> Y <input checked="" type="checkbox"/> N <small>IT IS THE RESPONSIBILITY OF THE APPLICANT TO RESERVE PARKING METER(S) APPLICATION LOCATED: https://bloomington.in.gov/transportation/parking/moving OR CONTACT PARKING SERVICES WITH QUESTIONS AT (812)349-3436</small>
C. RIGHT OF WAY TO BE USED/CLOSED: STREET NAME 1: <u>2801 S, Rogers St.</u> 1ST INTERSECTING STREET NAME: _____ 2ND INTERSECTING STREET NAME: _____ <input type="checkbox"/> ROAD CLOSURE <input type="checkbox"/> LANE CLOSURE 1 <input type="checkbox"/> 2 <input type="checkbox"/> 3 <input type="checkbox"/> <input type="checkbox"/> SIDEWALK* <input type="checkbox"/> BIKE LANE <input type="checkbox"/> OTHER _____ TRANSIT STOP? <input type="checkbox"/> Y <input type="checkbox"/> N PARKING LANE(S)** <input type="checkbox"/> Y <input type="checkbox"/> N <small>**NON-SCHEDULED</small> START DATE: _____ END DATE: _____ # OF DAYS*: <u>45</u> STREET NAME 2: _____ 1ST INTERSECTING STREET NAME: _____ 2ND INTERSECTING STREET NAME: _____ <input type="checkbox"/> ROAD CLOSURE <input type="checkbox"/> LANE CLOSURE 1 <input type="checkbox"/> 2 <input type="checkbox"/> 3 <input type="checkbox"/> <input type="checkbox"/> SIDEWALK* <input type="checkbox"/> BIKE LANE <input type="checkbox"/> OTHER _____ TRANSIT STOP? <input type="checkbox"/> Y <input type="checkbox"/> N PARKING LANE(S)** <input type="checkbox"/> Y <input type="checkbox"/> N <small>**NON-SCHEDULED</small> START DATE: _____ END DATE: _____ # OF DAYS*: _____ <small>*SIDEWALK CLOSURES FOR A PERIOD OR PERIODS TOTALING 2 HRS OR MORE SHALL INSTALL A WALKAROUND UNLESS OTHERWISE APPROVED DURING REVIEW</small>	F. IS THIS A <input type="checkbox"/> CBU* <input type="checkbox"/> COUNTY* <input type="checkbox"/> IU* <input type="checkbox"/> NP* PROJECT? PROJECT NAME: <u>S. Rogers St.</u> PROJECT #: <u>A029G86</u> PROJECT MGR.: <u>ZACHARY DECKARD</u> PROJECT MGR. #: <u>812 - 955 - 9437</u> <small>*CBU = CITY OF BLOOMINGTON UTILITIES *COUNTY = MONROE COUNTY *IU = INDIANA UNIVERSITY *NP = NOT-FOR-PROFIT AGENCY</small>
G. EXCAVATIONS: SQ FT OF PAVEMENT* EXCAVATIONS : _____ <small>*PAVEMENT INCLUDES: IN OR UNDER CONCRETE, OR ASPHALT INCLUDING CURBS</small> SQ FT OF NON-PAVEMENT* EXCAVATIONS: _____ <small>*DIRT, GRASS, GRAVEL, LANDSCAPE AREA OR OTHER UNPAVED SURFACE</small> LINEAL FT OF BORE*: <u>210 FEET</u> <small>*BORE PITS SHALL BE CALCULATED AS SQ FT EXCAVATIONS</small> # OF POLE INSTALLATIONS/REMOVAL: _____ SQ FT OF SIDEWALK RECONSTRUCTION*: _____ <small>*CONCRETE OR ASPHALT SIDEWALK/PATH BEING IMPROVED/REPLACED</small> SQ FT OF SIDEWALK NEW CONSTRUCTION*: _____ <small>*CONCRETE OR ASPHALT SIDEWALK/PATH THAT IS NEW INFRASTRUCTURE</small> # RESIDENTIAL DRIVEWAY INSTALLATION: _____	<div style="text-align: center;">  <small>Know Any Below. Call before you dig.</small> </div> <p style="text-align: center;"> <small>TO SUBMIT A LOCATE REQUEST 24 HRS A DAY, 7 DAYS A WEEK CALL 811 OR 800-382-5544 CALL 2 WORKING DAYS BEFORE YOU DIG. IT'S THE LAW.</small> </p>
STANDARD CLOSURE HOURS MON-FRI*: <u>9:00 AM - 3:00 PM & 6:00 PM - 9:00 PM</u> STANDARD CLOSURE HOURS <input type="checkbox"/> *NON-STANDARD CLOSURE HOURS <input type="checkbox"/> REQUESTED CLOSURE HOURS: _____ AM - _____ PM <small>*non-standard hours may not be allowed near schools, on arterials, or other circumstances and are subject to approval during the permitting process BMC 14.09.010 allows work from 6 AM to 10 PM without violating the noise ordinance (7AM to 9PM for pneumatic hammers)</small>	H. INDEMNIFICATION AGREEMENT: <small>The petitioner/applicant hereby agrees to hold harmless, defend and to indemnify the City of Bloomington from or against all claims, action, damages and expenses, including but not limited to reasonable attorney's fees or any alleged injury and/or death, to any person or damage to any property arising or alleged to have arisen out of any act of commission or omission on the part of the petitioner/applicant, his/her heirs, successors, or assigns regardless of whether such acts are the direct or indirect result of the public right-of-way use pursuant to this permit grant.</small> I AFFIRM, UNDER THE PENALTIES FOR PERJURY, THAT THE FOREGOING REPRESENTATIONS ARE TRUE. PRINT NAME: <u>Brian Busick</u> SIGNATURE:  DATE: <u>5 - 16 - 2022</u>

For Administration Use Only (applicable to CLOSURE approval)

Approved By: _____ BPW City Engineer Director Date: _____

Staff Representative: _____ Phone#: _____ Date: _____

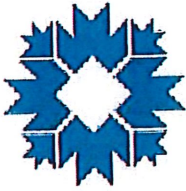

CITY OF BLOOMINGTON

RIGHT-OF-WAY USE PERMIT APPLICATION

401 N Morton Street, Suite 130
P.O. Box 100
Bloomington, IN 47402

Phone: (812) 349-3913
Fax: (812) 349-3520
Email:
engineering@bloomington.in.gov

ROW EXCAVATION ROW USE
ADDRESS OF ROW ACTIVITY: _____

<p>A. APPLICANT/AGENT INFORMATION:</p> <p>APPLICANT NAME: <u>Brian Busick</u></p> <p>E-MAIL: <u>bbusick@linealcontracting.com</u></p> <p>COMPANY: <u>Lineal Contracting Inc.</u></p> <p>ADDRESS: <u>2922 Mitchell Road</u></p> <p>CITY, STATE, ZIP: <u>Bedford In. 47421</u></p> <p>24-HR EMERGENCY CONTACT NAME: <u>Brian Busick</u></p> <p>24-HR CONTACT PHONE #: <u>812 - 521 - 3474</u></p> <p>INSURANCE #: <u>5000142821</u> COMPANY: <u>Thomburg</u></p> <p>BOND#: <u>69390442</u> COMPANY: <u>Western Surety</u></p> <p><small>* INSURANCE & BOND MUST BE ON FILE WITH THE CITY BEFORE PERMIT WILL BE ISSUED</small></p> <p style="text-align: center;">**SUBCONTRACTOR INFORMATION**</p> <p><small>(LIST ALL COMPANIES WORKING UNDER PRIMARY CONTRACTOR PERMIT)</small></p> <p>COMPANY NAME: _____</p>	<p>D. TRAFFIC CONTROL DEVICES*:</p> <p><input checked="" type="checkbox"/> CONES <input type="checkbox"/> ARROWBOARD</p> <p><input type="checkbox"/> LIGHTED BARRELS <input type="checkbox"/> TYPE 3 BARRICADES</p> <p><input checked="" type="checkbox"/> FLAGGERS <input type="checkbox"/> BPD OFFICER</p> <p><small>*PROVIDING MUTCD COMPLIANT TEMPORARY TRAFFIC CONTROL DEVICES AND MAINTENANCE OF TRAFFIC (NOT) PLAN IS YOUR RESPONSIBILITY AND REQUIRED. See page 3 for additional MOT resources; the graph paper can be used for your MOT site plan if needed or you can submit a separate sheet</small></p>
<p>B. WORK DESCRIPTION:</p> <p><input type="checkbox"/> POD/DUMPSTER <input type="checkbox"/> CRANE <input type="checkbox"/> SCAFFOLDING <input type="checkbox"/> CONSTRUCTION USE*</p> <p>(EXPLAIN): <u>Install underground fiber</u></p> <p><small>*EXCAVATION, LONG TERM USE FOR STORAGE OF MATERIAL/EQUIPMENT/WALKAROUND</small></p>	<p>E. METERED PARKING SPACES NEEDED: <input type="checkbox"/> Y <input type="checkbox"/> N</p> <p><small>IT IS THE RESPONSIBILITY OF THE APPLICANT TO RESERVE PARKING METER(S) APPLICATION LOCATED: https://bloomington.in.gov/transportation/parking/moving OR CONTACT PARKING SERVICES WITH QUESTIONS AT (812)349-3436</small></p>
<p>C. RIGHT OF WAY TO BE USED/CLOSED:</p> <p>STREET NAME 1: <u>S. STRANDS Dr.</u></p> <p>1ST INTERSECTING STREET NAME: _____</p> <p>2ND INTERSECTING STREET NAME: _____</p> <p><input type="checkbox"/> ROAD CLOSURE <input type="checkbox"/> LANE CLOSURE 1 <input type="checkbox"/> 2 <input type="checkbox"/> 3 <input type="checkbox"/></p> <p><input type="checkbox"/> SIDEWALK* <input type="checkbox"/> BIKE LANE <input type="checkbox"/> OTHER</p> <p>TRANSIT STOP? <input type="checkbox"/> Y <input type="checkbox"/> N PARKING LANE(S)** <input type="checkbox"/> Y <input type="checkbox"/> N <small>**NON-BUFFERED</small></p> <p>START DATE: _____ END DATE: _____ # OF DAYS*: <u>90</u></p> <p><small>When permit is issued</small></p> <p>STREET NAME 2: _____</p> <p>1ST INTERSECTING STREET NAME: _____</p> <p>2ND INTERSECTING STREET NAME: _____</p> <p><input type="checkbox"/> ROAD CLOSURE <input type="checkbox"/> LANE CLOSURE 1 <input type="checkbox"/> 2 <input type="checkbox"/> 3 <input type="checkbox"/></p> <p><input type="checkbox"/> SIDEWALK* <input type="checkbox"/> BIKE LANE <input type="checkbox"/> OTHER</p> <p>TRANSIT STOP? <input type="checkbox"/> Y <input type="checkbox"/> N PARKING LANE(S)** <input type="checkbox"/> Y <input type="checkbox"/> N <small>**NON-BUFFERED</small></p> <p>START DATE: _____ END DATE: _____ # OF DAYS*: _____</p> <p><small>*SIDEWALK CLOSURES FOR A PERIOD OR PERIODS TOTALING 24HRS OR MORE SHALL INSTALL A WALKAROUND UNLESS OTHERWISE APPROVED DURING REVIEW</small></p> <p>STANDARD CLOSURE HOURS MON-FRI*: <u>9:00 AM - 3:00 PM & 6:00 PM - 9:00 PM</u></p> <p>STANDARD CLOSURE HOURS <input type="checkbox"/> *NON-STANDARD CLOSURE HOURS <input type="checkbox"/></p> <p>REQUESTED CLOSURE HOURS: _____ AM - _____ PM</p> <p><small>*non-standard hours may not be allowed near schools, on arterials, or other circumstances and are subject to approval during the permitting process BMC 14.09.040 allows work from 6 AM to 10 PM without violating the noise ordinance (7AM to 9PM for pneumatic hammers)</small></p>	<p>F. IS THIS A <input type="checkbox"/> CBU* <input type="checkbox"/> COUNTY* <input type="checkbox"/> IU* <input type="checkbox"/> NP* PROJECT?</p> <p>PROJECT NAME: <u>S. Strands Dr.</u></p> <p>PROJECT #: <u>A0280AM</u></p> <p>PROJECT MGR: <u>Andrew Mullis</u></p> <p>PROJECT MGR #: <u>812 - 334 - 4521</u></p> <p><small>*CBU = CITY OF BLOOMINGTON UTILITIES *COUNTY = MONROE COUNTY *IU = INDIANA UNIVERSITY *NP = NOT-FOR-PROFIT AGENCY</small></p>
<p>G. EXCAVATIONS:</p> <p>SQ FT OF PAVEMENT* EXCAVATIONS : _____</p> <p><small>*PAVEMENT INCLUDES: IN OR UNDER CONCRETE, OR ASPHALT INCLUDING CURBS</small></p> <p>SQ FT OF NON-PAVEMENT* EXCAVATIONS: _____</p> <p><small>*DIRT, GRASS, GRAVEL, LANDSCAPE AREA OR OTHER UNPAVED SURFACE</small></p> <p>LINEAL FT OF BORE*: <u>20,000feet</u></p> <p><small>*BORE PITS SHALL BE CALCULATED AS SQ FT EXCAVATIONS</small></p> <p># OF POLE INSTALLATIONS/REMOVAL: _____</p> <p>SQ FT OF SIDEWALK RECONSTRUCTION*: _____</p> <p><small>*CONCRETE OR ASPHALT SIDEWALK/PATH BEING IMPROVED/REPLACED</small></p> <p>SQ FT OF SIDEWALK NEW CONSTRUCTION*: _____</p> <p><small>*CONCRETE OR ASPHALT SIDEWALK/PATH THAT IS NEW INFRASTRUCTURE</small></p> <p># RESIDENTIAL DRIVEWAY INSTALLATION: _____</p>	<div style="border: 1px solid black; padding: 5px;"> <p style="font-size: small;">TO SUBMIT A LOCATE REQUEST 24 HRS A DAY, 7 DAYS A WEEK CALL 811 OR 800-302-5544 CALL 2 WORKING DAYS BEFORE YOU DIG. IT'S THE LAW.</p> </div>
<p>H. INDEMNIFICATION AGREEMENT:</p> <p><small>The petitioner/applicant hereby agrees to hold harmless, defend and to indemnify the City of Bloomington from or against all claims, action, damages and expenses, including but not limited to reasonable attorney's fees or any alleged injury and/or death to any person or damage to any property arising, or alleged to have arisen out of any act of commission or omission on the part of the petitioner/applicant, his/her heirs, successors, or assigns regardless of whether such acts are the direct or indirect result of the public right-of-way use pursuant to this permit grant.</small></p> <p>I AFFIRM, UNDER THE PENALTIES FOR PERJURY, THAT THE FOREGOING REPRESENTATIONS ARE TRUE.</p> <p>PRINT NAME: <u>Brian Busick</u></p> <p>SIGNATURE: <u>Brian Busick</u></p> <p>DATE: <u>5/12/2022</u></p>	

For Administration Use Only (applicable to CLOSURE approval)

Approved By: _____ BPW City Engineer Director Date: _____

Staff Representative: _____ Phone#: _____ Date: _____



Board of Public Works Staff Report

Project/Event:	Sidewalk closure and replacement at Lofton Apartments
Staff Representative:	Alex Gray
Petitioner/Representative:	Strauser Construction
Date:	February 13 th , 2024

Report: Strauser Construction is working on the Lofton Apartments at 2611 E 3rd St before the Bypass and are requesting a sidewalk closure for finishing work at the apartments and for the replacement of the sidewalk. The closure would be from March 9th, 2024 through March 16th, 2024.

The detour route would be from the crosswalks at S Woodcrest Dr and E 3rd St to the crosswalk at the intersection of the Bypass and E 3rd St.



THE LOFTON - APARTMENTS
2611 E. THIRD STREET
BLOOMINGTON, IN 47401

Approved By:

Reviewed By: WSR

Sheet Issue/Revision Date:

8/13/2022	CITY REVIEW NO. 1 - RESPONSE
7/8/2022	ISSUED FOR CONSTRUCTION
8/10/2022	CBU REVIEW NO. 2 - RESPONSE
3/24/2023	PLAN UPDATE

Sheet Title:
MAINTENANCE OF TRAFFIC PLAN

Drawing Number:
C901

Project Number:
SDB-2020-520



ALL TRAFFIC CONTROL DEVICES, SIGNAGE, AND THEIR INSTALLATION SHALL COMPLY WITH THE INDIANA MANUAL ON TRAFFIC CONTROL DEVICES, INDOT STANDARDS, AND TO THE SATISFACTION OF THE CITY OF BLOOMINGTON ENGINEERS

LEGEND
 PROPOSED DETOUR
 CONSTRUCTION ZONE

- PLAN NOTES**
- "SIDEWALK CLOSED AHEAD (ARROW) CROSS HERE" (R9-11) SIGN TO BE PLACED AT THE NEAREST INTERSECTION WITH EXISTING TRAFFIC CONTROL DEVICES TO REROUTE SIDEWALK TRAFFIC TO THE OTHER SIDE OF THE ROAD.
 - "SIDEWALK CLOSED" (R9-9) SIGN TO BE PLACED WITH BARRICADES AT THE EXTENTS OF THE CONSTRUCTION CLOSURE AREA.
 - "DETOUR (PEDESTRIAN AND BICYCLE)" (M4-9a (L&R)) SIGNS TO BE PLACED AT ANY DIRECTIONAL CHANGES ALONG THE ALTERNATE ROUTE TO DIRECT TRAFFIC ALONG THE DETOUR. SIGNS SHALL BE PLACED ACCORDINGLY TO DISPLAY THE CORRECT DIRECTION OF THE DETOUR.

- GENERAL NOTES**
- COORDINATE LOCATION AND INSTALLATION OF TEMPORARY TRAFFIC CONTROL SIGNAGE WITH EMILY HERR, CITY OF BLOOMINGTON PUBLIC IMPROVEMENT MANAGER, (812) 349-3913
 - ALL TRAFFIC CONTROL DEVICES, SIGNAGE, PAVEMENT MARKINGS, AND THEIR INSTALLATION, SHALL COMPLY WITH THE INDIANA MANUAL ON UNIFORM TRAFFIC CONTROL DEVICES
 - SIGNAGE AND PAVEMENT MARKING TO BE MAINTAINED THROUGHOUT DURATION OF THE PROJECT
 - UPON COMPLETION OF PROJECT OR INTERIM MODIFICATIONS OF LANE CLOSURES, MODIFY SIGNAGE AND PAVEMENT MARKINGS TO PRE-EXISTING CONDITIONS. COORDINATE WITH CITY OF BLOOMINGTON REPRESENTATIVES.

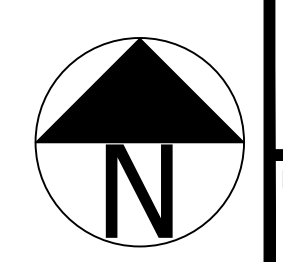



CITY OF BLOOMINGTON RIGHT-OF-WAY USE PERMIT APPLICATION

401 N Morton Street, Suite 130
P.O. Box 100
Bloomington, IN 47402

Phone: (812) 349-3913
Fax: (812) 349-3520
Email:
engineering@bloomington.in.gov

ROW EXCAVATION ROW USE

ADDRESS OF ROW ACTIVITY: 2611 E Third Street

A. APPLICANT/AGENT INFORMATION: APPLICANT NAME: <u>Strauser Construction Co., Inc.</u> E-MAIL: <u>wmorris@strausercci.com</u> COMPANY: <u>Strauser Construction Co., Inc.</u> ADDRESS: <u>453 S. Clarizz Blvd.</u> CITY, STATE, ZIP: <u>Bloomington, IN 47401</u> 24-HR EMERGENCY CONTACT NAME: <u>Ryan Strauser</u> 24-HR CONTACT PHONE #: <u>812-360-1503</u> INSURANCE #*: _____ COMPANY: <u>Hylant - Selective</u> BOND #*: _____ COMPANY: <u>Hylant -Nationwide</u> <small>* INSURANCE & BOND MUST BE ON FILE WITH THE CITY BEFORE PERMIT WILL BE ISSUED</small>	D. TRAFFIC CONTROL DEVICES*: <input checked="" type="checkbox"/> CONES <input checked="" type="checkbox"/> ARROWBOARD <input type="checkbox"/> LIGHTED BARRELS <input type="checkbox"/> TYPE 3 BARRICADES <input type="checkbox"/> FLAGGERS <input type="checkbox"/> BPD OFFICER <small>*PROVIDING MUTCD COMPLIANT TEMPORARY TRAFFIC CONTROL DEVICES AND MAINTENANCE OF TRAFFIC (MOT) PLAN IS YOUR RESPONSIBILITY AND REQUIRED See page 3 for additional MOT resources; the graph paper can be used for your MOT site plan if needed or you can submit a separate sheet</small>
SUBCONTRACTOR INFORMATION <small>(LIST ALL COMPANIES WORKING UNDER PRIMARY CONTRACTOR PERMIT)</small> COMPANY NAME: _____	E. METERED PARKING SPACES NEEDED: <input type="checkbox"/> Y <input checked="" type="checkbox"/> N <small>IT IS THE RESPONSIBILITY OF THE APPLICANT TO RESERVE PARKING METER(S) APPLICATION LOCATED: https://bloomington.in.gov/transportation/parking/moving OR CONTACT PARKING SERVICES WITH QUESTIONS AT (812)349-3436</small>
B. WORK DESCRIPTION: <input type="checkbox"/> POD/DUMPSTER <input type="checkbox"/> CRANE <input type="checkbox"/> SCAFFOLDING <input checked="" type="checkbox"/> CONSTRUCTION USE* (EXPLAIN): <u>Closure of sidewalk for work / replace at completion</u> <small>*EXCAVATION, LONG TERM USE FOR STORAGE OF MATERIAL/EQUIPMENT/WALKAROUND</small>	F. IS THIS A <input checked="" type="checkbox"/> CBU* <input type="checkbox"/> COUNTY* <input type="checkbox"/> IU* <input type="checkbox"/> NP* PROJECT? PROJECT NAME: <u>The Lofton Apartments</u> PROJECT #: _____ PROJECT MGR.: _____ <small>*CBU = CITY OF BLOOMINGTON UTILITIES *COUNTY = MONROE COUNTY *IU= INDIANA UNIVERSITY *NP= NOT-FOR-PROFIT AGENCY</small>
C. RIGHT OF WAY TO BE USED/CLOSED: STREET NAME 1: <u>Sidewalk along Third Street south of building</u> 1ST INTERSECTING STREET NAME: _____ 2ND INTERSECTING STREET NAME: _____ <input type="checkbox"/> ROAD CLOSURE <input type="checkbox"/> LANE CLOSURE 1 <input type="checkbox"/> 2 <input type="checkbox"/> 3 <input type="checkbox"/> <input checked="" type="checkbox"/> SIDEWALK* <input type="checkbox"/> BIKE LANE <input type="checkbox"/> OTHER TRANSIT STOP? <input type="checkbox"/> Y <input checked="" type="checkbox"/> N PARKING LANE(S)** <input type="checkbox"/> Y <input checked="" type="checkbox"/> N <small>**NON-METERED</small> START DATE: <u>3/09/24</u> END DATE: <u>3/16/24</u> # OF DAYS*: <u>8</u>	G. EXCAVATIONS: SQ FT OF PAVEMENT* EXCAVATIONS : <u>800 sf</u> <small>*PAVEMENT INCLUDES: IN OR UNDER CONCRETE, OR ASPHALT INCLUDING CURBS</small> SQ FT OF NON-PAVEMENT* EXCAVATIONS: <u>NA</u> <small>*DIRT, GRASS, GRAVEL, LANDSCAPE AREA OR OTHER UNPAVED SURFACE</small> LINEAL FT OF BORE*: <u>NA</u> <small>*BORE PITS SHALL BE CALCULATED AS SQ FT EXCAVATIONS</small> # OF POLE INSTALLATIONS/REMOVAL: <u>NA</u> SQ FT OF SIDEWALK RECONSTRUCTION*: <u>800 sf</u> <small>*CONCRETE OR ASPHALT SIDEWALK/PATH BEING IMPROVED/REPLACED</small> SQ FT OF SIDEWALK NEW CONSTRUCTION*: <u>NA</u> <small>*CONCRETE OR ASPHALT SIDEWALK/PATH THAT IS NEW INFRASTRUCTURE</small> #RESIDENTIAL DRIVEWAY INSTALLATION: <u>NA</u>
STREET NAME 2: _____ 1ST INTERSECTING STREET NAME: _____ 2ND INTERSECTING STREET NAME: _____ <input type="checkbox"/> ROAD CLOSURE <input type="checkbox"/> LANE CLOSURE 1 <input type="checkbox"/> 2 <input type="checkbox"/> 3 <input type="checkbox"/> <input type="checkbox"/> SIDEWALK* <input type="checkbox"/> BIKE LANE <input type="checkbox"/> OTHER TRANSIT STOP? <input type="checkbox"/> Y <input type="checkbox"/> N PARKING LANE(S)** <input type="checkbox"/> Y <input type="checkbox"/> N <small>**NON-METERED</small> START DATE: _____ END DATE: _____ # OF DAYS*: _____ <small>*SIDEWALK CLOSURES FOR A PERIOD OR PERIODS TOTALING 24HRS OR MORE SHALL INSTALL A WALKAROUND UNLESS OTHERWISE APPROVED DURING REVIEW</small>	 TO SUBMIT A LOCATE REQUEST 24 HRS A DAY, 7 DAYS A WEEK CALL 811 OR 800-382-5544 CALL 2 WORKING DAYS BEFORE YOU DIG. ITS THE LAW.
STANDARD CLOSURE HOURS MON-FRI*: 9:00 AM - 3:00 PM & 6:00 PM - 9:00 PM STANDARD CLOSURE HOURS <input type="checkbox"/> *NON-STANDARD CLOSURE HOURS <input type="checkbox"/> REQUESTED CLOSURE HOURS: <u>24 hours</u> AM - _____ PM <small>*non-standard hours may not be allowed near schools, on arterials, or other circumstances and are subject to approval during the permitting process BMC 14.09.040 allows work from 6 AM to 10 PM without violating the noise ordinance (7AM to 9PM for pneumatic hammers)</small>	H. INDEMNIFICATION AGREEMENT: The petitioner/applicant hereby agrees to hold harmless, defend and to indemnify the City of Bloomington from or against all claims, action, damages and expenses, including but not limited to reasonable attorney's fees or any alleged injury and/or death to any person or damage to any property arising, or alleged to have arisen out of any act of commission or omission on the part of the petitioner/applicant, his/her heirs, successors, or assigns regardless of whether such acts are the direct or indirect result of the public right-of-way use pursuant to this permit grant. I AFFIRM, UNDER THE PENALTIES FOR PERJURY, THAT THE FOREGOING REPRESENTATIONS ARE TRUE. PRINT NAME: <u>Ryan M. Strauser</u> SIGNATURE: <u>Ryan M. Strauser</u> DATE: <u>03/24/2024</u>

For Administration Use Only (applicable to CLOSURE approval)

Approved By: _____ BPW City Engineer Director Date: _____

Staff Representative: _____ Phone#: _____ Date: _____



Board of Public Works Staff Report

Project/Event: Gilliatte General Contractors
Staff Representative: Kyle Baugh
Petitioner/Representative: Thomas Rittman
Date: February 13, 2024

Report: Gilliatte General Contractors is requesting daily intermittent sidewalk closures on the west side of S Grant St along with metered parking reservation for 3 parking stalls. This request is to accommodate Material deliveries for work occurring at 228 S Grant. The traffic control would be in place from February 14th 2024 through February 28th 2024

Gilliatte General Contractors has supplied maintenance of traffic plans for all work. They have also sent notice to adjacent property owners, Bloomington Transit, and Bloomington Fire and Police Departments via a formal written letter.



GILLIATTE GENERAL CONTRACTORS, INC.
2515 Bloyd Avenue, Indianapolis, IN 46218
Phone: 317-638-3355 / Fax: 317-634-5997

February 5, 2024
Board of Public Works
401 N Morton St, Suite 120
Bloomington IN 47404

Dear Board Members:

Please accept this correspondence as a request to perform construction activities at 218 S. Grant Street within the City R.O.W. The work includes shutting down a portion of the sidewalk intermittently during the day to accept deliveries of material and exporting material and debris off the site as well as shutting down the (3) parking spaces next to the site for access in and out of the construction site.

It is our intent to shut down the sidewalk in front of the site for (2) weeks starting 2/14 while we complete earthwork and foundations. We will then get separate daily closures as needed when the sidewalk is being utilized. The (3) parking spaces will remain closed for the duration of the project. While the sidewalk is closed, we will redirect pedestrian traffic to the East side of Grant St. via crosswalks at 3rd St and 4th St. This is shown on the maintenance of traffic plan.

We plan to notify adjacent property owners, Bloomington Transit, and Bloomington Fire & Police Departments via a formal written letter describing our proposed street closure and to include with that letter a maintenance of traffic plan. We request to be included in the Board Meeting scheduled for 2/13/2024 seeking approval for this work.

Sincerely,
GILLIATTE GENERAL CONTRACTORS, INC.

Thomas Ritman
Project Manager

TR/ds

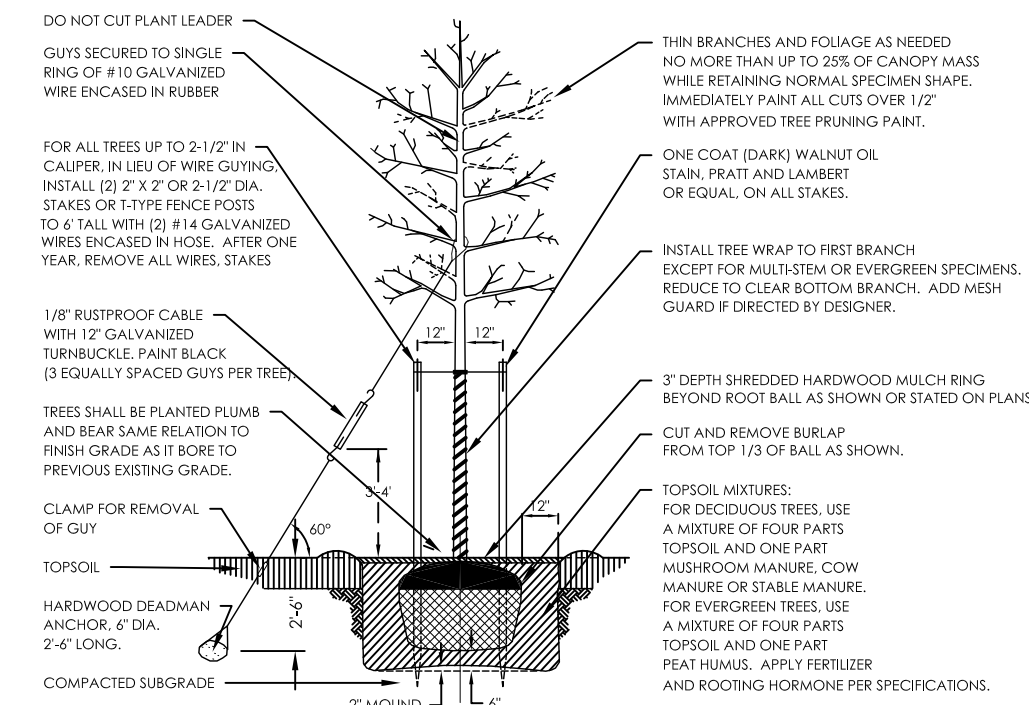

TREE PLANTING (with GUYING or STAKING)
NOT TO SCALE

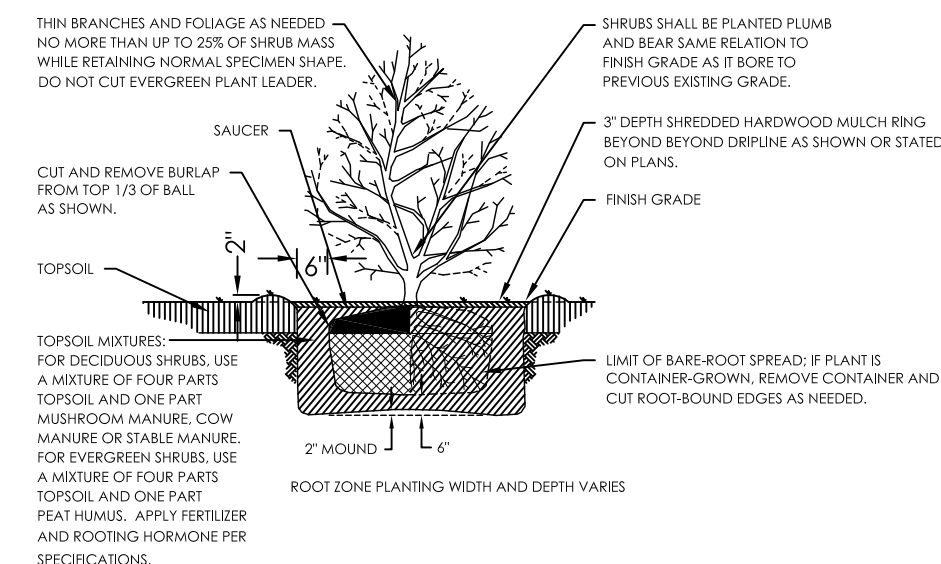

SHRUB PLANTING
NOT TO SCALE

LANDSCAPE PLANT LIST

SYMBOL	MARK	BOTANICAL NAME	COMMON NAME	QUANTITY	SIZE & CONDITION
LARGE DECIDUOUS TREES					
	AR	ACER REBRUM 'FRANKSRED'	RED SUNSET 'RED' MAPLE	-	2" CAL., B & B
DECIDUOUS ORNAMENTAL and SMALL STREETSCAPE TREES					
	Aa	AMELANCHIOR arborea	DOWNY SERVICEBERRY	1	2" CAL., B & B
	GB	GINKGO BILOBA	PRINCETON SENTRY GINKO	2	2" CAL., B & B
DECIDUOUS and BROADLEAF EVERGREEN SHRUBS					
	CA	CEANOTHUS AMERICANUS	NEW JERSEY TEA	-	3 GALLON
	FG	FOTHERGILLA GARDENII	DWARF FOTHERGILLA	4	3 GALLON
	IV	ITEA VIRGINICA SPRICH	LITTLE HENRY SWEETSPICE	-	3 GALLON
	VP	VIBURNUM DENTATUM	ARROWWOOD VIBURNUM	-	3 GALLON
PERENNIALS, GRASSES and FERNS					
	AA	ASTER AZUREUS	SKY BLUE ASTER	-	1 GALLON
	CP	CAREX PENNSYLVANICA	COMMON OAK SEDGE	11	1 GALLON
	KC	KOELERIA CRISTATA	JUNE GRASS	2	1 GALLON

NOTE: MINIMUM SIZE FOR PERENNIALS, GRASSES, FERNS and ENDANGERED PLANTS TO BE 1 GALLON. IF 1 GALLON SIZES ARE UNAVAILABLE, 2 PLUGS (MINIMUM 2"x3") CAN BE SUBSTITUTED FOR ONE, 1 GALLON PLANT

*CONTAINER OR BALL AND BURLAP CONDITION ACCEPTABLE

NOTE: PLANT SUBSTITUTIONS NOT PERMITTED WITHOUT PRIOR APPROVAL FROM C.O.B. PLANNING (812) 349-3423

PLANT LABELING LEGEND:

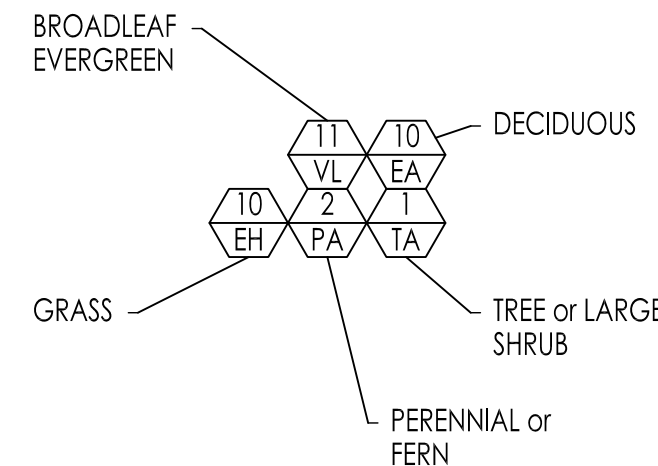

SITE PLAN NOTES:

- NOT USED.
- LANDSCAPE GRAVEL on (2) - LAYERS of 10 mil VISQUEEN.
- DRAINAGE SWALE with FLOW LINE SLOPE of 1/8" PER FOOT (MINIMUM).
- REMOVE HEAVY TIMBER RETAINING WALL and ADJUST GRADE BETWEEN BUILDINGS as SHOWN.
- NOT USED.
- NEW 4'-8" w. CONC. SIDEWALK.
- NEW POURED CONC. ENTRY STEPS.
- NEW WOOD FRAMED REAR DECK and STAIRS.
- NEW HVAC EXTERIOR CONDENSING UNITS on CONC. PADS.
- NEW WATER SERVICE LINE and METER.
- NEW SAN. SEWER LINE and CLEAN OUT.
- NEW UNDERGROUND ELECTRICAL SERVICE LINE from EXISTING POWER POLE.

NOTE: CONTRACTOR SHALL VERIFY ALL UTILITY LOCATIONS and DEPTHS and NOTIFY ARCHITECT/ENGINEER of ANY INACCURACIES in LOCATION or ELEVATION or ANY CONFLICTS PRIOR to and AFTER ANY EXCAVATION. NO PAYMENT SHALL BE MADE to CONTRACTOR for UTILITY DESTRUCTION or UNDERGROUND CHANGES REQUIRED DUE to CONFLICTING ELEVATIONS.

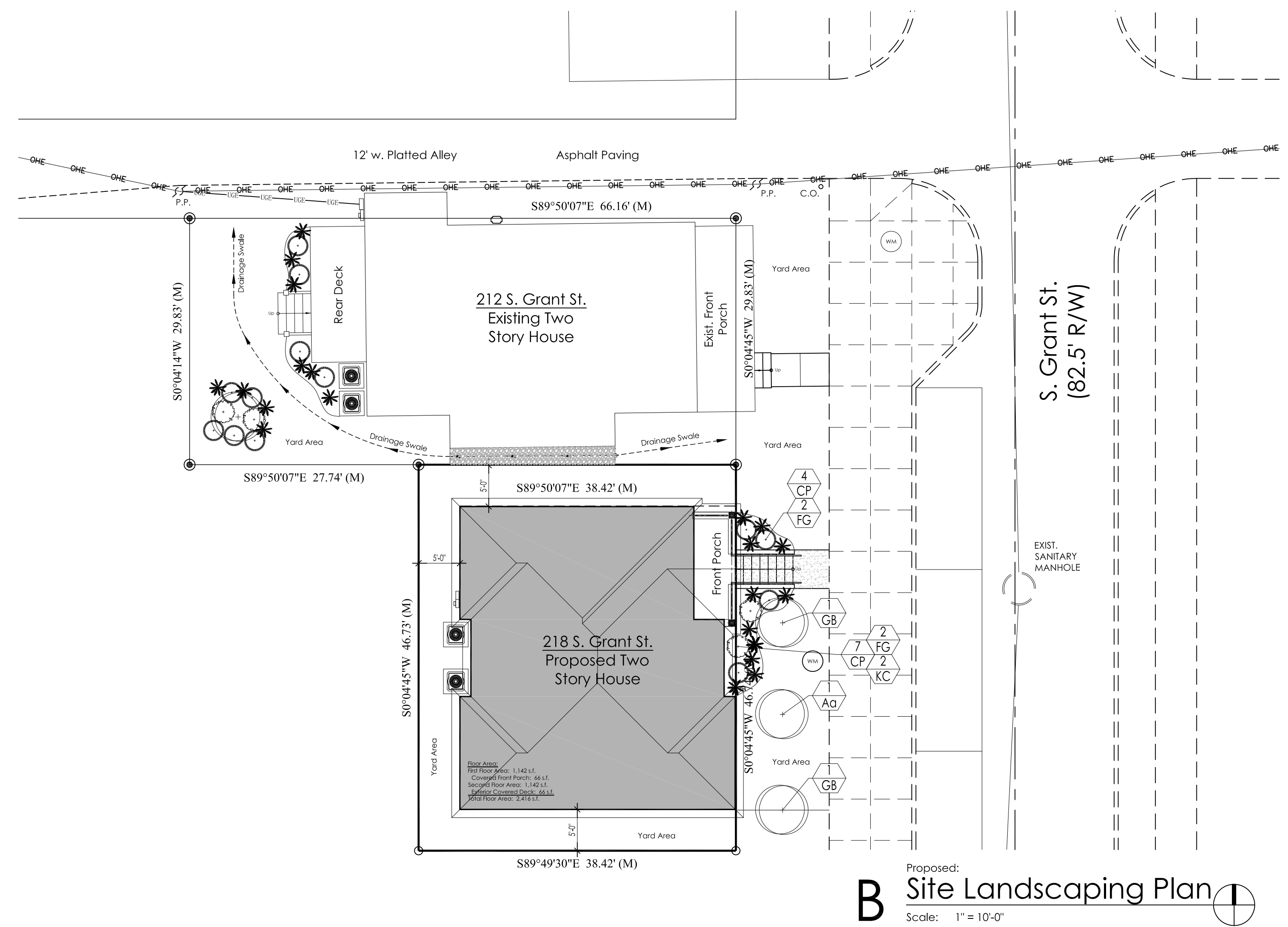

B Site Landscaping Plan
Scale: 1" = 10'-0"

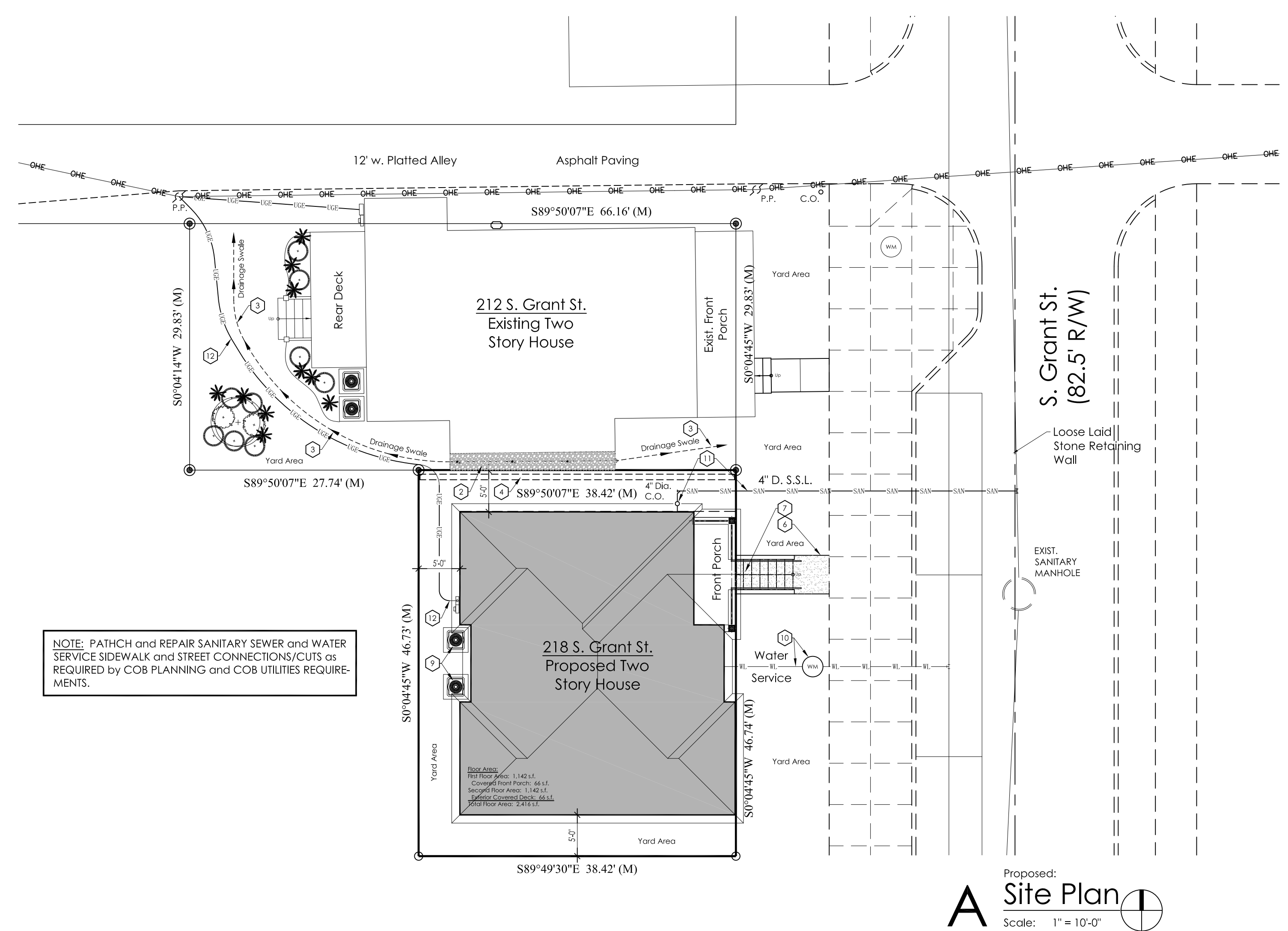

A Site Plan
Scale: 1" = 10'-0"

mca MARC CORNETT ARCHITECTS
101 EAST HURWOOD AVE
BLOOMINGTON, INDIANA 47408
P. 812.325.5964 E. MAIL: marc@cornettarch.com

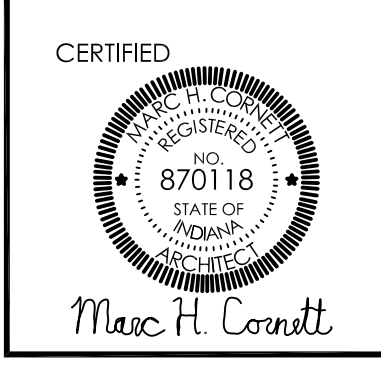

REVISIONS

Proposed:
GRANT STREET RESIDENCE
218 S. Grant Street
Bloomington, Indiana

PROJECT NO.: 2023-06
DATE: 11.13.23
DRAWN BY:
CHECKED BY: MHC

PROPOSED SITE PLAN and LANDSCAPING PLAN
C.101

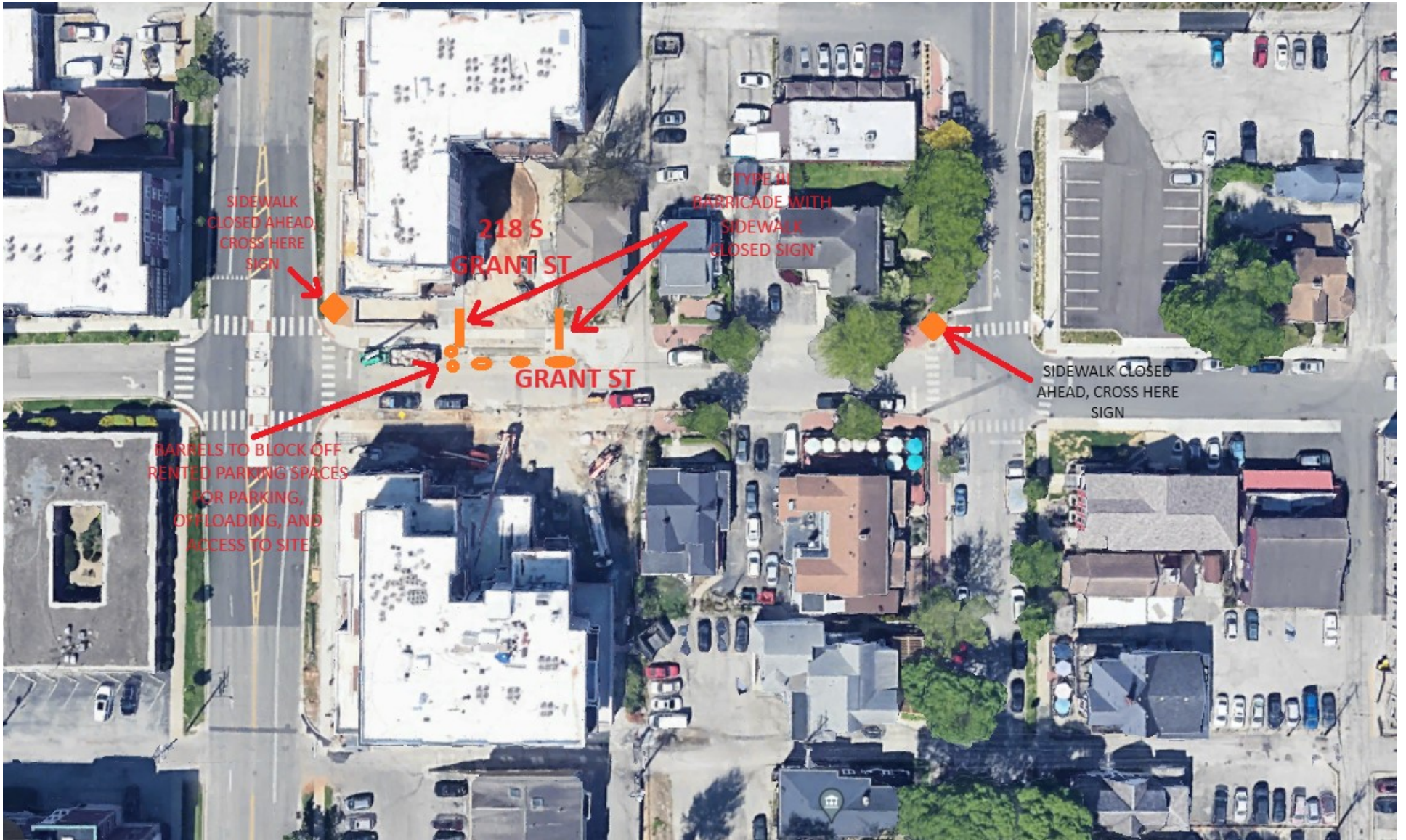

SIDEWALK
CLOSED AHEAD
CROSS HERE
SIGN

218 S
GRANT ST

TYPE A1
BARRICADE WITH
SIDEWALK
CLOSED SIGN

GRANT ST

SIDEWALK CLOSED
AHEAD, CROSS HERE
SIGN

BARRELS TO BLOCK OFF
RENTED PARKING SPACES
FOR PARKING,
OFFLOADING, AND
ACCESS TO SITE



Board of Public Works Staff Report

Project/Event: City of Bloomington Utilities Atlas Ballroom Storm Project

Staff Representative: Kyle Baugh

Petitioner/Representative: Matt Dabertin

Date: February 13th, 2024

Report: City of Bloomington Utilities is requesting a two week lane closure for a storm water reconstruction project next to 209 S College (Atlas Ballroom) for the eastern lane adjacent to the sidewalk during normal working hours. The work would start on March 25th and is expected to conclude on April 8th, 2024. City of Bloomington Utilities has supplied maintenance of traffic plans for the work.



Board of Public Works Staff Report

Project/Event: 2024 Applied Engineering Services Walnut St and Morton Street Garage on call and inspection services

Petitioner/Representative: PW Parking Services, Jess Goodman

Staff Representative: Jess Goodman

Date: 1.30.2024

Report:

Applied Engineering shall provide the following services:

SCOPE OF SERVICES – STUDY

1. The professional design services include the engineering to develop a narrative study, to be used solely with respect to this project, for the above-described Scope of Work.
2. Gather and review existing drawings for review if available.
3. Visit the site to review existing conditions.
4. Narrative Study review submittals at 75% Study Completion plus the Final Study. At each submittal, electronic files will be forwarded to the City of Bloomington for all printing and distribution.
5. Review comments from each study submittal will be returned to Applied for incorporation into the design. Applied will provide written responses to written review comments.
6. Virtual design review/presentation meetings corresponding to the review submittals, as requested.
7. Cost opinion for our design corresponding to the review submittal plus Final Study.
8. The final deliverable is the study set, consisting of a narrative and cost opinions as required, submitted to the City of Bloomington in PDF format.

We recommend using Applied Engineering Services for this project.

Total cost of contract = \$16,000.00

Project Funding Source: 101-26-260000-54510 (CRED Fund Line)



Recommend **Approval** **Denial by:** Jess Goodman

City of Bloomington Contract and Purchase Justification Form

Vendor: Applied Engineering Services

Contract Amount: \$16,000

This form should be completed and attached to the contract documents and forwarded to the Legal Department Attorney assigned to your Department. Contracts will not be approved by the Controller if a completed form is not included with the contract documents.

PURCHASE INFORMATION

1. Check the box beside the procurement method used to initiate this procurement: (Attach a quote or bid tabulation if applicable)

<input type="checkbox"/> Request for Quote (RFQ)	<input type="checkbox"/> Request for Proposal (RFP)	<input checked="" type="checkbox"/> Sole Source	<input type="checkbox"/> Not Applicable (NA)
<input type="checkbox"/> Invitation to Bid (ITB)	<input type="checkbox"/> Request for Qualifications (RFQu)	<input type="checkbox"/> Emergency Purchase	

2. List the results of procurement process. Give further explanation where requested.

# of Submittals:	Yes	No	Was the lowest cost selected? (If no, please state below why it was not.)
Met city requirements?	<input checked="" type="checkbox"/>	<input type="checkbox"/>	<input type="checkbox"/> Yes <input checked="" type="checkbox"/> No
Met item or need requirements?	<input checked="" type="checkbox"/>	<input type="checkbox"/>	Applied Engineering was recommended by CE Solutions for Mechanical, Electrical, and Plumbing engineering services for the Morton and Walnut St. garages.
Was an evaluation team used?	<input type="checkbox"/>	<input checked="" type="checkbox"/>	
Was scoring grid used?	<input type="checkbox"/>	<input checked="" type="checkbox"/>	
Were vendor presentations requested?	<input type="checkbox"/>	<input checked="" type="checkbox"/>	

3. State why this vendor was selected to receive the award and contract:

Applied Engineering was recommended for a Mechanical, Electric, and plumbing evaluation of the Morton and Walnut St. garages. CE Solutions is our current engineering services vendor for garage repair and is a sole source provider for garage engineering services. They were selected in 2017 for engineering services and produced our structural engineering report we have been using to repair our facilities.

Print/Type Name

Print/Type Title

Department

AGREEMENT FOR CONSULTING SERVICES

This Agreement, entered into on this 29th day of January, 2024, by and between the City of Bloomington Parking Services Department through the Board of Public Works (hereinafter referred to as "Board"), and Applied Engineering services, (hereinafter referred to as "Consultant"),

WITNESSETH:

WHEREAS, the Board wishes to enhance the services it provides by engaging in efforts to receive temporary Engineering services necessary to meet workload demands; and,

WHEREAS, the Board requires the services of a professional engineering consultant in order to perform tasks including Mechanical, Electrical, and Plumbing Engineering services for the City of Bloomington Morton St., and Walnut St. garage facilities, which shall be hereinafter referred to as "Services"; and

WHEREAS, it is in the public interest that such Services be undertaken and performed; and

WHEREAS, Consultant is willing and able to provide such Services to the Board;

NOW, THEREFORE, in consideration of the mutual covenants herein contained, the parties hereto agree as follows:

Article 1. Scope of Services: Consultant shall provide required Services for the Board as set for in Exhibit A, Scope of Services. Exhibit A is attached hereto and incorporated herein by reference as though fully set forth.

Consultant shall diligently pursue its work under this Agreement and shall complete the Services as described in Exhibit A in a timely manner. Consultant shall perform all Services as expeditiously as is consistent with professional skill and care and the orderly progress of the work.

In the performance of Consultant's work, Consultant agrees to maintain such coordination with the Board as may be requested and desirable, including primary coordination with the Parking Services Department officials designated by the Board as project coordinator(s).

Consultant agrees that any information or documents, including digital GIS information, supplied by the Board pursuant to Article 3, below, shall be used by Consultant for this project only, and shall not be reused or reassigned for any purpose.

Article 2. Standard of Care: Consultant shall perform all services under this Agreement in a skillful and competent manner in accordance with normally accepted standards of the architectural and engineering professions and with that degree of care and skill which a professional engineer or architect would exercise under the same or similar circumstance.

Article 3. Responsibilities of the Board: The Board shall have the following responsibilities under this Agreement and shall meet these responsibilities in a timely manner so as not to delay the orderly progress of the Services, and Consultant shall be entitled to rely upon the accuracy and completeness of information supplied by the Board:

A. Information/Reports

Provide Consultant with reports, studies, site characterizations, regulatory decisions and similar information relating to the Services that Consultant may rely upon without independent verification unless specifically identified as requiring such verification.

B. Representative

The Board hereby designates Jessica Goodman, Parking Garage Manager, Parking Services Department (“Goodman”), to serve as the Board’s representative for the project. “Goodman” shall have the authority to transmit instructions, receive information, interpret and define the Board’s requirements and make decisions with respect to the Services.

C. Decisions

Provide all criteria and full information as to Board’s requirements for the Services and make timely decisions on matters relating to the Services.

Article 4. Compensation: The Board shall pay Consultant a fee based on the payment schedule set forth in Exhibit B – Compensation. Exhibit B is attached hereto and incorporated herein by reference as though fully set forth. The total compensation paid for the project, including fees and expenses, shall not exceed the amount of sixteen thousand (\$16,000). These sums include salaries, payroll taxes and insurance, employee fringe benefits, general overhead costs, profit, and project related expenses. Payments will be made according to Consultant's monthly progress statements for each phase and shall be invoiced for the work completed only.

Additional assignments or additional services not set forth in Exhibit A, changes in work, or incurred expenses in excess of the rates set forth in Exhibit B must be authorized in writing by the Board or the Board's designated representative prior to such work being performed, or expenses incurred. The Board shall not make payment for any unauthorized work or expenses. Claims for additional work or expenses must be submitted within thirty (30) days of the completion of the work or expenditure, and must be accompanied by a statement of itemized costs.

1. Timing and Format for Billing:

Invoices shall be submitted monthly for Services completed at the time of billing and are due upon receipt. Invoices shall be considered past due if not paid within forty-five (45) calendar days of the due date. Such invoices shall be prepared in a form supported by documentation as the Board may reasonably require.

Tasks shall be invoiced separately, either as separate lines on a single invoice, or on separate invoices at the Board's direction.

2. Billing Records:

Consultant shall maintain accounting records of its costs in accordance with generally accepted accounting practices. Access to such records will be provided during normal business hours with reasonable notice during the term of this Agreement and for 3 years after completion.

Article 5. Appropriation of Funds: Notwithstanding any other provision of this Agreement, if funds for the continued fulfillment of this Agreement by the Board are at any time not forthcoming or are insufficient, through failure of any entity, including the Board itself, to appropriate funds or otherwise, then the Board shall have the right to terminate this Agreement without penalty as set forth in Article 7 herein.

Article 6. Schedule: Consultant shall perform the Services according to the schedule set forth in Exhibit C, Project Schedule. Exhibit C is attached hereto and incorporated herein by reference as though fully set forth. The time limits established by this schedule shall not be exceeded, except for reasonable cause as mutually agreed by the parties.

Article 7. Termination: In the event of a party's substantial failure to perform in accordance with the terms of this Agreement, the other party shall have the right to terminate the Agreement upon written notice. The nonperforming party shall have fourteen (14) calendar days from the receipt of the termination notice to cure or to submit a plan for cure acceptable to the other party.

The Board may terminate or suspend performance of this Agreement at the Board's prerogative at any time upon written notice to the Consultant. The Consultant shall terminate or suspend performance of the Services on a schedule acceptable to the Board, and the Board shall pay the Consultant for all the Services performed up to the date that written notice is received, plus reasonable termination or suspension expenses. Upon restart, an equitable adjustment shall be made to the Consultant's compensation and the schedule of services.

Upon termination or suspension of this Agreement, all finished or unfinished reports, drawings, collections of data and other documents generated by Consultant in connection with this Agreement shall become the property of the Board, as set forth in Article 11 herein.

Article 8. Identity of Consultant: Consultant acknowledges that one of the primary reasons for its selection by the Board to perform the duties described in this Agreement is the qualification and experience of the principal personnel whom Consultant has represented will be responsible there for. Consultant thus agrees that the work to be done pursuant to this Agreement shall be performed by the principal personnel described in Exhibit D, Key Personnel, and such other personnel in the employ under contract or under the supervision of Consultant. Exhibit D is attached hereto and incorporated herein by reference as though fully set forth. The Board reserves the right to reject any of the Consultant's personnel or proposed outside professional subconsultants, and the Board reserves the right to request that acceptable replacement personnel be assigned to the project.

Article 9. Cost Estimates: All estimates of construction cost to be provided by Consultant shall represent the best judgment of Consultant based upon the information currently available and upon Consultant's background and experience with respect to projects of this nature. It is recognized, however, that neither Consultant nor the Board has control over the cost of labor, materials or equipment, over contractors' method of determining costs for services, or over competitive bidding, market or negotiating conditions. Accordingly, Consultant cannot and does not warrant or represent that the proposals or construction bids received will not vary from the cost estimates provided pursuant to this Agreement.

Article 10. Reuse of Documents: All documents, including but not limited to, drawings, specifications and computer software prepared by Consultant pursuant to this Agreement are instruments of service in respect to this project. They are not intended or represented to be suitable for reuse by the Board or others on modifications or extensions of this project or on any other project. The Board may elect to reuse such documents; however, any reuse without prior written verification or adaptation by Consultant for the specific purpose intended will be at the Board's sole risk and without liability or legal exposure to the Consultant. The Board shall

indemnify and hold harmless the Consultant against all judgments, losses, damages, injuries and expenses arising out of or resulting from such reuse. Any verification or adaptation of documents by the Consultant will entitle the Consultant to additional compensation at rates to be agreed upon by the Board and the Consultant.

Article 11. Ownership of Documents and Intellectual Property: All documents, drawings and specifications, including digital format files, prepared by Consultant and furnished to the Board as part of the Services shall become the property of the Board. Consultant shall retain its ownership rights in its design, drawing details, specifications, data bases, computer software and other proprietary property. Intellectual property developed, utilized or modified in the performance of the Services shall remain the property of the Consultant.

Article 12. Independent Contractor Status: During the entire term of this Agreement, Consultant shall be an independent contractor, and in no event shall any of its personnel, agents or sub-contractors be construed to be, or represent themselves to be, employees of the Board.

Article 13. Indemnification: To the fullest extent permitted by law, Consultant shall indemnify and hold harmless the City of Bloomington, the Board, and the officers, agents and employees of the City and the Board from any and all claims, demands, damages, costs, expenses or other liability arising out of bodily injury or property damage (collectively "Claims") but only to the extent that such Claims are found on a comparative basis of fault to be caused by any negligent act or omission of Consultant or Consultant's officers, directors, partners, employees, or subconsultants in the performance of services under this Agreement.

Article 14. Insurance: During the performance of any and all Services under this Agreement, Consultant shall maintain the following insurance in full force and effect:

- a. General Liability Insurance, with a minimum combined single limit of \$1,000,000 for each occurrence and \$2,000,000 in the aggregate.
- b. Automobile Liability Insurance, with a minimum combined single limit of \$1,000,000 for each person and \$1,000,000 for each accident.
- c. Professional Liability Insurance ("Errors and Omissions Insurance") with a minimum combined single limit of \$1,000,000 for each occurrence, and \$2,000,000 in the aggregate.
- d. Workers' Compensation Insurance in accordance with the statutory requirements of Title 22 of the Indiana Code.

All insurance policies shall be issued by an insurance company authorized to issue such insurance in the State of Indiana. The City of Bloomington, the Board, and the officers, employees and agents of each shall be included as additional insured under both the General Liability Insurance and Automobile Liability Insurance policies, and the policies shall stipulate that the insurance will operate as primary insurance and that no other insurance effected by the City will be called upon to contribute to a loss hereunder.

Consultant shall provide evidence of each insurance policy to the Board prior to the commencement of work under the Agreement. Approval of the insurance by the Board shall not relieve or decrease the extent to which Consultant may be held responsible for payment of damages resulting from service or operations performed pursuant to this Agreement. If Consultant fails or refuses to procure or maintain the insurance required by these provisions, or fails or refuses to furnish the Board required proof that the insurance has been procured and is in force and paid for, Board shall have the right at Board's election to forthwith terminate the Agreement.

Article 15. Conflict of Interest: Consultant declares that it has no present interest, nor shall it acquire any interest, direct or indirect, which would conflict with the performance of Services required under this Agreement. The Consultant agrees that no person having any such interest shall be employed in the performance of this Agreement.

Article 16. Waiver: No failure of either party to enforce a term of this Agreement against the other shall be construed as a waiver of that term, nor shall it in any way affect the party's right to enforce that term. No waiver by any party of any term of this Agreement shall be considered to be a waiver of any other term or breach thereof.

Article 17. Severability: The invalidity, illegality or unenforceability of any provision of this Agreement or the occurrence of any event rendering any portion or provision of this Agreement void shall in no way affect the validity or enforceability of any other portion or provision of this Agreement. Any void provision shall be deemed severed from this Agreement, and the balance of the Agreement shall be construed and enforced as if it did not contain the particular provision to be held void. The parties further agree to amend this Agreement to replace any stricken provision with a valid provision that comes as close as possible to the intent of the stricken provision. The provisions of this Article shall not prevent this entire Agreement from being void should a provision which is of the essence of this Agreement be determined void.

Article 18. Assignment: Neither the Board nor the Consultant shall assign any rights or duties under this Agreement without the prior written consent of the other party; provided, however, Consultant may assign its rights to payment without the Board's consent. Unless otherwise stated in the written consent to an assignment, no assignment will release or discharge the assignor from any obligation under this Agreement.

Article 19. Third Party Rights: Nothing in this Agreement shall be construed to give any rights or benefits to anyone other than the Board and the Consultant.

Article 20. Governing Law and Venue: This Agreement shall be governed by the laws of the State of Indiana. Venue of any disputes arising under this Agreement shall be in the Monroe County Circuit Court, Monroe County, Indiana.

Article 21. Non-Discrimination: Consultant shall comply with City of Bloomington Ordinance 2.21.020 and all other federal, state and local laws and regulations governing non-discrimination in employment.

Consultant understands that the City of Bloomington prohibits its employees from engaging in harassment or discrimination of any kind, including harassing or discriminating against independent contractors doing work for the City. If the Consultant believes that a City employee engaged in such conduct towards Consultant and/or any of its employees, Contractor or its employees may file a complaint with the City department head in charge of the Consultant's work and/or with the City human resources department or the Bloomington Human Rights Commission. The City takes all complaints of harassment and discrimination seriously and will take appropriate disciplinary action if it finds that any City employee engaged in such prohibited conduct.

Article 22. Compliance with Laws: In performing the Services under this Agreement, Consultant shall exercise usual and customary professional care to comply with any and all applicable federal, state and local statutes, ordinances, plans, and regulations, including any and all regulations for protection of the environment. When appropriate, Consultant shall advise Board of any and all applicable regulations and approvals required by the Federal Environmental Management Agency (FEMA). Where such statutes, ordinances, plans or regulations of any public authority having any jurisdiction on the project are in conflict, Consultant shall proceed using its best judgment only after attempting to resolve any such conflict between such governmental agencies, and shall notify the Board in a timely manner of the conflict, attempts of resolution, and planned course of action.

Article 23. Notices: Any notice required by this Agreement shall be made in writing to the addresses specified below:

Board:

City of Bloomington
Parking Services Dept.
Attn: Jessica Goodman/Michelle Wahl
401 N. Morton Street, Suite 130
Bloomington, Indiana 47404

Consultant:

Applied Engineering Services
Attn: Mark Lehman, RCDD
5975 Castle Creek Parkway N Drive, Suite 300
Indianapolis, IN 46250

Nothing contained in this Article shall be construed to restrict the transmission of routine communications between representatives of the Board and the Consultant.

Article 24. Intent to be Bound: The Board and the Consultant each bind itself and its successors, executors, administrators, permitted assigns, legal representatives and, in the case of a partnership, its partners to the other party to this Agreement, and to the successors, executors, administrators, permitted assigns, legal representatives and partners of such other party in respect to all provisions of this Agreement.

Article 25. Integration and Modification: This Agreement, including all Exhibits incorporated by reference, represents the entire and integrated agreement between the Board and the Consultant. It supersedes all prior and contemporaneous communications, representations and agreements, whether oral or written, relating to the subject matter of this Agreement.

Article 26. Verification of New Employees' Employment Status: Consultant is required to enroll in and verify the work eligibility status of all newly-hired employees through the E-Verify program. (This is not required if the E-Verify program no longer exists.) Consultant shall sign an affidavit, attached as Exhibit E, affirming that Consultant does not knowingly employ an unauthorized alien. "Unauthorized alien" is defined at 8 U.S. Code 1324a(h)(3) as a person who is not a U.S. citizen or U.S. national and is not lawfully admitted for permanent residence or authorized to work in the U.S. under 8U.S. Code Chapter 12 or by the U.S. Attorney General.

Consultant and any of its subconsultants may not knowingly employ or contract with an unauthorized alien, or retain an employee or contract with a person that the Consultant or any of its subconsultants learns is an unauthorized alien. If the Board obtains information that the Consultant or any of its subconsultants employs or retains an employee who is an unauthorized alien, the Board shall notify the Consultant or its subconsultants of the Agreement violation and require that the violation be remedied within thirty (30) days of the date of notice. If the Consultant or any of its subconsultants verify the work eligibility status of the employee in

question through the E-Verify program, there is a rebuttable presumption that the Consultant or its subconsultant did not knowingly employ an unauthorized alien. If the Consultant or its subconsultant fails to remedy the violation within the thirty (30) day period, the Board shall terminate the Agreement, unless the Board determines that terminating the Agreement would be detrimental to the public interest or public property, in which case the Board may allow the Agreement to remain in effect until the Board procures a new Consultant. If the Board terminated the Agreement, the Consultant or its subconsultant is liable to the Board for actual damages.

Consultant shall require any subconsultants performing work under this Agreement to certify to the Consultant that, at the time of certification, the subconsultant does not knowingly employ or contract with an unauthorized alien and the subconsultant has enrolled in and is participating in the E-Verify program. Consultant shall maintain on file all subconsultants' certifications throughout the term of this Agreement with the Board.

Exhibit E is attached hereto and incorporated herein by reference as though fully set forth.

Article 27. No Collusion: Consultant is required to certify that it has not, nor has any other member, representative, or agent of Consultant, entered into any combination, collusion or agreement with any person relative to the price to be offered by any person nor prevented any person from making an offer nor induced anyone to refrain from making an offer and that this offer is made without reference to any other offer. Consultant shall sign an affidavit, attached hereto as **Exhibit F**, affirming that Consultant has not engaged in any collusive conduct.

Exhibit F is attached hereto and incorporated herein by reference as though fully set forth. This Agreement may be modified only by a written amendment signed by both parties hereto.

IN WITNESS WHEREOF, the parties hereto have caused this Agreement to be executed the day and year first written above.

Owner

Consultant

City of Bloomington
Board of Public Works

Applied Engineering Services

By: _____
Kyla Cox Deckard, President

Mark Lehman, RCDD, CxA Associate

By: _____
Elizabeth Karon, Vice President

By: _____
James Roach, Secretary

By: _____
Margie Rice, Corporation Counsel

January 24, 2024

Proposal No. 005-24

Ms. Jessica Goodman
Parking Garage Manager
City of Bloomington
401 North Morton Street
Bloomington, IN 47404

**Re: Engineering Services Proposal
Walnut and Morton Street Garage Assessment Study
Bloomington, Indiana**

Dear Jessica:

Applied Engineering Services (Applied) is pleased to submit this proposal to provide mechanical, electrical, and plumbing (MEP) engineering services for the above-referenced project. The basis for this proposal is our site visit on January 19, 2024. Thank you for this opportunity.

BACKGROUND

The City of Bloomington is looking to have an assessment of the existing MEP systems performed at two of their older parking garages. The assessment should determine which systems need to be replaced or upgraded within the next year, within the next 1-5 years, and after 5 years.

SCOPE OF WORK

We understand the scope of work to be as follows:

1. Assess the existing conditions of the electrical, mechanical, plumbing, and fire protection systems.
2. Provide a report noting observations of existing conditions and recommendations for repairs and upgrades.
3. The report should note the life expectancy of the existing systems and suggested timeframe for repairs or replacement.
4. The report should include associated costs for implementing recommendations.
5. The scope of work does not include design or construction documents. If desired, a separate proposal will be created for engineering construction documents and construction support.

SCOPE OF SERVICES – STUDY

1. The professional design services include the engineering to develop a narrative study, to be used solely with respect to this project, for the above-described Scope of Work.
2. Gather and review existing drawings for review if available.
3. Visit the site to review existing conditions.
4. Narrative Study review submittals at 75% Study Completion plus the Final Study. At each submittal, electronic files will be forwarded to the City of Bloomington for all printing and distribution.
5. Review comments from each study submittal will be returned to Applied for incorporation into the design. Applied will provide written responses to written review comments.
6. Virtual design review/presentation meetings corresponding to the review submittals, as requested.
7. Cost opinion for our design corresponding to the review submittal plus Final Study.
8. The final deliverable is the study set, consisting of a narrative and cost opinions as required, submitted to the City of Bloomington in PDF format.

ENGINEERING SERVICES INVESTMENT

We propose to complete the engineering work outlined herein on a fixed fee basis, including our typical expenses for mileage and shipping/courier. In determining our fee, we estimated the engineering-hours to accomplish this project effort. A detailed description of our proposed fee is as follows:

Basic Services

75% Study	\$ 11,700.00
Final Study	<u>4,300.00</u>
Total	\$ 16,000.00

We will invoice progress monthly. If additional construction phase meetings/site visits are requested, we may request Additional Services.

SCHEDULE

Applied proposes the following schedule. Changes to the schedule will be as agreed upon by both the City of Bloomington and Applied. Applied will start on the project upon written acceptance of this proposal or written notice-to-proceed.

Notice to Proceed - Design Start	Week 0
Site Visit (Suggested Date, TBD)	Week 2
Submit 75% Study	Week 6
75% Study Review Meeting	Week 7
Substantial Final Study	Week 9

STAFFING

The following design professionals are proposed as the leadership for this project:

Mark Lehman, RCDD, CxA
Tammy Murray, PE, LEED AP
David Chadburn

Project Manager
Electrical Engineer
Project Mechanical Engineer

ASSUMPTIONS

Applied assumes the following regarding the scope of work outlined in this proposal:

1. The City of Bloomington will provide the existing parking garage drawings in PDF format for Applied to evaluate existing systems.
2. Asbestos removal and related design, as applicable, is not included in this proposal.
3. All review comments will be received in a timely manner prior to issuance of the Final Study. Any review comments received after Final Study may be considered as Additional Services.
4. Site topographical surveys, including the depth of existing utilities, and landscape/tree identification of the relevant areas, are not included in this proposal and will be provided to Applied in AutoCAD format, if required.
5. Architectural, landscape, civil, and structural design services are outside the scope of this proposal.
6. Commissioning services and arc flash analysis services are outside the scope of this proposal.
7. Presentation drawings for use in fundraising or other communications are outside the scope of this proposal.
8. If successful with this proposal, it is anticipated that a Standard Form of Agreement between Owner and Architect (revised to Engineer) such as AIA B101 will be executed. It is also anticipated that this proposal letter will be an attachment to the Agreement.

ADDITIONAL SERVICES

Should it be determined the services provided by Applied will increase beyond the above-described scope of work and services due to influences beyond our control, notification will be given to the City of Bloomington. Applied will issue a formal request for adjustment, which shall provide the basis for the request and the impact on the project schedule. This will be based upon our standard Billing Rate Schedule. We will continue services on all other aspects of the project. We will proceed with the services as outlined on the additional service request after resolution of the issue in question.

We sincerely appreciate the opportunity to provide this proposal. If the terms of this proposal meet with your approval, please indicate your acceptance below and return a copy for our files. Please let me know if you have any questions or comments.

Sincerely,



Mark Lehman, RCDD, CxA
Associate

Accepted By: City of Bloomington

Signature: _____

Printed Name: _____

Title: _____

Date: _____



Board of Public Works Claim Register

Invoice Date Range 02/03/24 - 02/16/24

Vendor	Invoice Description	Contract #	Payment Date	Invoice Amount
Fund 101 - General Fund (S0101)				
Department 01 - Animal Shelter				
Program 010000 - Main				
Account 43430 - Animal Adoption Fees				
Zaid Al-Nasser	01-refund adoption fee-feline-1/26/24		02/16/2024	90.00
Michael Bass	01-refund adoption fee-canine-emergency surgery-1/23/24		02/16/2024	40.00
Kristina Kokot	01-refund adoption fee-canine-1/21/24		02/16/2024	100.00
Account 43430 - Animal Adoption Fees Totals			Invoice 3 Transactions	\$230.00
Account 52110 - Office Supplies				
6530 - Office Depot, INC	01-Large white board		02/16/2024	285.11
Account 52110 - Office Supplies Totals			Invoice 1 Transactions	\$285.11
Account 52210 - Institutional Supplies				
4045 - Datamars, INC	01-300 Microchips		02/16/2024	1,525.23
7508 - Elanco US INC	01-antibiotics		02/16/2024	369.64
4586 - Hill's Pet Nutrition Sales, INC	01-Dog food		02/16/2024	85.68
4586 - Hill's Pet Nutrition Sales, INC	01-dog food		02/16/2024	114.24
4586 - Hill's Pet Nutrition Sales, INC	01-Prescription Vet Food		02/16/2024	256.42
4633 - Midwest Veterinary Supply, INC	01-vinyl exam gloves (L)		02/16/2024	27.35
4633 - Midwest Veterinary Supply, INC	01-Nebulizer parts		02/16/2024	44.00
4633 - Midwest Veterinary Supply, INC	01-Fluids-lactated ringers		02/16/2024	78.72
4633 - Midwest Veterinary Supply, INC	01-Ketamine		02/16/2024	101.52
4633 - Midwest Veterinary Supply, INC	01-Anxiety meds, antifungal shampoos, syringes		02/16/2024	136.26



Board of Public Works Claim Register

Invoice Date Range 02/03/24 - 02/16/24

4633 - Midwest Veterinary Supply, INC	01-Antiparasitic, culture, antibiotics	02/16/2024	353.06
4633 - Midwest Veterinary Supply, INC	01-Antibiotics, syringes, antiparasitics	02/16/2024	549.90
4633 - Midwest Veterinary Supply, INC	01-Antibiotics, wound treatment, syringes	02/16/2024	790.06
Account 52210 - Institutional Supplies Totals		Invoice 13 Transactions	\$4,432.08
Account 52310 - Building Materials and Supplies			
4832 - Animal Care Equipment & Services, LLC	01-2 hose & reel replacements for Stray Rooms	02/16/2024	1,764.50
Account 52310 - Building Materials and Supplies Totals		Invoice 1 Transactions	\$1,764.50
Account 52340 - Other Repairs and Maintenance			
313 - Fastenal Company	01-6 bottle brushes	02/16/2024	30.96
313 - Fastenal Company	01-Laundry detergent	02/16/2024	96.98
313 - Fastenal Company	01-Mop head, squeegee, scrub brushes, towels	02/16/2024	387.92
Account 52340 - Other Repairs and Maintenance Totals		Invoice 3 Transactions	\$515.86
Account 53130 - Medical			
6529 - BloomingPaws, LLC	01-Spay/Neuter Surgeries	02/16/2024	686.64
3278 - Boehringer Ingelheim Animal Health (Merial, INC)	01-insulin	02/16/2024	167.16
54639 - Shake Veterinary Services, INC (Town & Country Vet	01-Spay/Neuter surgeries	02/16/2024	98.30
54639 - Shake Veterinary Services, INC (Town & Country Vet	01-Vet visit, x-rays, splinting	02/16/2024	161.00
54639 - Shake Veterinary Services, INC (Town & Country Vet	01-Spay/Neuter surgeries	02/16/2024	540.00
Account 53130 - Medical Totals		Invoice 5 Transactions	\$1,653.10
Account 53220 - Postage			
3560 - First Financial Bank / Credit Cards	01-UPS-BOH Shipping 01/17/24	02/16/2024	12.67
3560 - First Financial Bank / Credit Cards	01-USPS BOH Shipping 01/05/24	02/16/2024	13.15
453 - ULINE, INC	01 - shipping for product return	02/16/2024	133.66



Board of Public Works Claim Register

Invoice Date Range 02/03/24 - 02/16/24

Account 53220 - Postage Totals		Invoice 3	\$159.48
		Transactions	
Account 53510 - Electrical Services			
223 - Duke Energy	02-Facilities Summary-FS#4 bill-11/30/23-01/02/24	02/07/2024	1,456.31
Account 53510 - Electrical Services Totals		Invoice 1	\$1,456.31
		Transactions	
Account 53630 - Machinery and Equipment Repairs			
6253 - O'Dell Equipment & Supply, INC	01-Dryer Repair-1/27/24	02/16/2024	442.27
Account 53630 - Machinery and Equipment Repairs Totals		Invoice 1	\$442.27
		Transactions	
Account 53910 - Dues and Subscriptions			
3560 - First Financial Bank / Credit Cards	01-National Animal Care & Control Assoc Dues 2024	02/16/2024	150.00
Account 53910 - Dues and Subscriptions Totals		Invoice 1	\$150.00
		Transactions	
Program 010000 - Main Totals		Invoice 32	\$11,088.71
		Transactions	
Program 010001 - Donations Over \$5K			
Account 52210 - Institutional Supplies			
4137 - Patterson Veterinary Supply, INC	01-Thyroid meds	02/16/2024	11.72
4137 - Patterson Veterinary Supply, INC	01-heartworm med and antibiotics	02/16/2024	3,584.17
Account 52210 - Institutional Supplies Totals		Invoice 2	\$3,595.89
		Transactions	
Program 010001 - Donations Over \$5K Totals		Invoice 2	\$3,595.89
		Transactions	
Department 01 - Animal Shelter Totals		Invoice 34	\$14,684.60
		Transactions	
Department 02 - Public Works			
Program 020000 - Main			
Account 46060 - Other Violations			
Theodore Alling	26-Ticket balance was only \$30, mailed a check for \$60	02/16/2024	30.00
EAN Holdings LLC	26-Sent check for \$240, one ticket on check already paid	02/16/2024	60.00



Board of Public Works Claim Register

Invoice Date Range 02/03/24 - 02/16/24

Account **53160 - Instruction**

3560 - First Financial Bank / Credit Cards

02-Notary CE for April Rosenberger

Account **46060 - Other Violations** Totals Invoice 2 Transactions \$90.00

02/16/2024 49.37

Account **53160 - Instruction** Totals Invoice 1 Transactions \$49.37

Account **53410 - Liability / Casualty Premiums**

19618 - ONI Risk Partners, INC, DBA EPIC Insurance Midwest

12-Insurance Premium 01/01/24-01/01/25

02/16/2024 371,287.61

19618 - ONI Risk Partners, INC, DBA EPIC Insurance Midwest

12-Property Insurance Premium 01/01/24-01/01/25

02/16/2024 120,225.93

19618 - ONI Risk Partners, INC, DBA EPIC Insurance Midwest

12-Crime Renewal Insurance Premium 01/01/24-01/01/25

02/16/2024 521.67

19618 - ONI Risk Partners, INC, DBA EPIC Insurance Midwest

12-Excess Liability Insurance Premium 01/01/24-01/01/25

02/16/2024 16,923.70

19618 - ONI Risk Partners, INC, DBA EPIC Insurance Midwest

12-Excess Workers Comp Insurance Premium 01/01/24-01/01/25

02/16/2024 47,744.22

Account **53410 - Liability / Casualty Premiums** Totals Invoice 5 Transactions \$556,703.13

Account **53990 - Other Services and Charges**

1136 - The Indiana Rail Road Company

02-IN Rail Road Expenses for Repair of Retaining Wall on E 10th

02/16/2024 4,064.50

Account **53990 - Other Services and Charges** Totals Invoice 1 Transactions \$4,064.50

Account **54510 - Other Capital Outlays**

60 - Monroe County Solid Waste Management District

02-Forklift for DPW Sanitation Division

02/16/2024 5,000.00

19278 - Milestone Contractors, LP

20-Bd Held Retain ReleaseCCMG 2022-2 WInslow Rd Proj DES#2201321

02/16/2024 2,349.33

Account **54510 - Other Capital Outlays** Totals Invoice 2 Transactions \$7,349.33

Program **020000 - Main** Totals Invoice 11 Transactions \$568,256.33

Department **02 - Public Works** Totals Invoice 11 Transactions \$568,256.33

Department **03 - City Clerk**

Program **030000 - Main**

Account **52110 - Office Supplies**



Board of Public Works Claim Register

Invoice Date Range 02/03/24 - 02/16/24

6530 - Office Depot, INC	03-certificate holder, legal pads	02/16/2024	145.93
6530 - Office Depot, INC	03-Lysol spray, Lysol wipes, batteries	02/16/2024	21.90
6530 - Office Depot, INC	03-pens, labeler, black/white tape, card stock	02/16/2024	71.47
6530 - Office Depot, INC	03-note pads	02/16/2024	12.60
6530 - Office Depot, INC	03-tape dispenser	02/16/2024	23.99
Account 52110 - Office Supplies Totals		Invoice 5	<u>\$275.89</u>
		Transactions	
Account 52420 - Other Supplies			
3404 - J.R. Watkins & Family, INC (Signs Now)	03- update council nameplates	02/16/2024	182.00
6530 - Office Depot, INC	03-ceramic heater	02/16/2024	58.99
6530 - Office Depot, INC	03-shelf lamp	02/16/2024	129.99
6530 - Office Depot, INC	03-desk lamp	02/16/2024	54.99
Account 52420 - Other Supplies Totals		Invoice 4	<u>\$425.97</u>
		Transactions	
Account 53230 - Travel			
5461 - Nicole Bolden	03-Clerk AIM NEO conference Bolden travel expenses	02/16/2024	138.68
5461 - Nicole Bolden	03-Clerk Creating Change Conference Bolden travel expenses	02/16/2024	1,039.08
8674 - Jennifer Rose Crossley	03-Clerk AIM NEO conference Crossley travel expenses	02/16/2024	94.32
8662 - Sofia McDowell	03-per diem/pkg-AIM NEO-Indy-1/16-1/18/2024	02/16/2024	288.60
Account 53230 - Travel Totals		Invoice 4	<u>\$1,560.68</u>
		Transactions	
Account 53910 - Dues and Subscriptions			
7231 - International Institute of Municipal Clerks	03-IIMC 2024 annual dues-S. McDowell	02/16/2024	35.00
7231 - International Institute of Municipal Clerks	03- IIMC 2024 annual dues-N. Bolden	02/16/2024	85.00
Account 53910 - Dues and Subscriptions Totals		Invoice 2	<u>\$120.00</u>
		Transactions	
Program 030000 - Main Totals		Invoice 15	<u>\$2,382.54</u>
		Transactions	



Board of Public Works Claim Register

Invoice Date Range 02/03/24 - 02/16/24
 Invoice 15 \$2,382.54
 Transactions

Department **04 - Economic & Sustainable Dev**

Program **040000 - Main**

Account **52110 - Office Supplies**

53125 - Mr. Copy, INC

04-Art Exhibition at Black y Brown Festival 02/16/2024 123.30

Account **52110 - Office Supplies** Totals Invoice 1 \$123.30
 Transactions

Account **53910 - Dues and Subscriptions**

3560 - First Financial Bank / Credit Cards

04-MailChimp Monthly Subscription - Jan 2024 02/16/2024 45.00

3560 - First Financial Bank / Credit Cards

04-Prorated fee for Trello Subscription 1/5-7/8/2024 02/16/2024 60.49

Account **53910 - Dues and Subscriptions** Totals Invoice 2 \$105.49
 Transactions

Account **53960 - Grants**

4397 - A & D Cycling Enterprises, LLC (Revolution Bike)

04-E-Bike Voucher Program Grant 2023-Beal 02/16/2024 500.00

Account **53960 - Grants** Totals Invoice 1 \$500.00
 Transactions

Program **040000 - Main** Totals Invoice 4 \$728.79
 Transactions

Program **04TECH - Trades Tech Center**

Account **53990 - Other Services and Charges**

9150 - Multicraft Fire LLC

04-Trades District Tech Ctr-Fire Protection-Pay App 1 02/16/2024 6,650.00

9150 - Multicraft Fire LLC

04-Trades District Tech Ctr-Fire Protection-Pay App 2 02/16/2024 8,075.00

Account **53990 - Other Services and Charges** Totals Invoice 2 \$14,725.00
 Transactions

Program **04TECH - Trades Tech Center** Totals Invoice 2 \$14,725.00
 Transactions

Department **04 - Economic & Sustainable Dev** Totals Invoice 6 \$15,453.79
 Transactions

Department **05 - Common Council**

Program **050000 - Main**



Board of Public Works Claim Register

Invoice Date Range 02/03/24 - 02/16/24

Account 53910 - Dues and Subscriptions

3956 - West Publishing Corporation (Thomson Reuters)	10-2024 Annual Westlaw Electronic Subscription	02/16/2024	5,741.57
Account 53910 - Dues and Subscriptions Totals		Invoice 1	\$5,741.57
		Transactions	

Account 53990 - Other Services and Charges

3560 - First Financial Bank / Credit Cards	05 - Eventbrite Fee for Panel Discussion on Community Safety	02/16/2024	24.99
Account 53990 - Other Services and Charges Totals		Invoice 1	\$24.99
		Transactions	
Program 050000 - Main Totals		Invoice 2	\$5,766.56
		Transactions	
Department 05 - Common Council Totals		Invoice 2	\$5,766.56
		Transactions	

Department 06 - Controller's Office

Program 060000 - Main

Account 53160 - Instruction

3560 - First Financial Bank / Credit Cards	06-GFOA Conference registration June 9-12-24 (J.McClellan)	02/16/2024	500.00
3560 - First Financial Bank / Credit Cards	06-GFOA Conference registration June 9-12-24 (C. Gilliland)	02/16/2024	500.00
Account 53160 - Instruction Totals		Invoice 2	\$1,000.00
		Transactions	

Account 53640 - Hardware and Software Maintenance

3560 - First Financial Bank / Credit Cards	06-CFS Tax Software upgrade for electronic filing	02/16/2024	164.00
Account 53640 - Hardware and Software Maintenance Totals		Invoice 1	\$164.00
		Transactions	

Account 53730 - Machinery and Equipment Rental

371 - Pitney Bowes, INC	06-Mail Machine Analytics 10/26/23-01/25-24	02/16/2024	150.24
Account 53730 - Machinery and Equipment Rental Totals		Invoice 1	\$150.24
		Transactions	

Account 53910 - Dues and Subscriptions

3913 - Indiana League Of Municipal Clerks & Treasurers	06-2024 ILMCT Membership dues for Controller (J McClellan)	02/16/2024	282.00
371 - Pitney Bowes, INC	06-Mail Machine Analytics 10/26/23-01/25-24	02/16/2024	134.88



Board of Public Works Claim Register

Invoice Date Range 02/03/24 - 02/16/24

Account 53990 - Other Services and Charges

910 - FORVIS, LLP

5648 - Reedy Financial Group, PC

Account **53910 - Dues and Subscriptions** Totals

Invoice 2 Transactions \$416.88

06-Annual financial report for 2021, Interim for 2022

02/16/2024 27,720.00

06-Annexation Consulting - billing through 1/31/24

02/16/2024 15,518.10

Account **53990 - Other Services and Charges** Totals

Invoice 2 Transactions \$43,238.10

Program **060000 - Main** Totals

Invoice 8 \$44,969.22

Department **06 - Controller's Office** Totals

Transactions Invoice 8 \$44,969.22
Transactions

Department 07 - Engineering

Program 070000 - Main

Account 52430 - Uniforms and Tools

8541 - Amazon.com Sales, INC (Amazon.com Services LLC)

07-Digital Level

02/16/2024 121.30

8541 - Amazon.com Sales, INC (Amazon.com Services LLC)

07-Snow Brushes

02/16/2024 23.82

Account **52430 - Uniforms and Tools** Totals

Invoice 2 Transactions \$145.12

Account 53910 - Dues and Subscriptions

3560 - First Financial Bank / Credit Cards

07-2024 IACE Dues Renewal Andrew Cibor

02/16/2024 75.00

Account **53910 - Dues and Subscriptions** Totals

Invoice 1 Transactions \$75.00

Account 53990 - Other Services and Charges

3560 - First Financial Bank / Credit Cards

07-doxpop Subscription Public Records Access 1/13-2/12/24

02/16/2024 19.05

3444 - Rundell Ernstberger Associates, INC

07-On-Call Engineering Serv-thru 12/31/23

02/16/2024 2,245.00

6378 - ANN-KRISS, LLC

19-Eng Dept reconfiguration/remodel-2/1/24

BC 2024-001 02/16/2024 7,000.00

Account **53990 - Other Services and Charges** Totals

Invoice 3 Transactions \$9,264.05

Account 54310 - Improvements Other Than Building

5637 - Shrewsbury & Associates, LLC

07-DT Curb Ramps PH 3-CE-serv thru 08/26/23

BC 2022-065 02/16/2024 16,572.15



Board of Public Works Claim Register

Invoice Date Range 02/03/24 - 02/16/24

5637 - Shrewsberry & Associates, LLC	07-DT Curb Ramps PH 3-CE-serv thru 06/30/23	BC 2022-065	02/16/2024	8,935.42
5637 - Shrewsberry & Associates, LLC	07-DT Curb Ramps PH 3-CE-serv thru 09/30/23	BC 2022-065	02/16/2024	1,444.19
Account 54310 - Improvements Other Than Building Totals		Invoice 3		<u>\$26,951.76</u>
Program 070000 - Main Totals		Transactions		
		Invoice 9		<u>\$36,435.93</u>
Department 07 - Engineering Totals		Transactions		
		Invoice 9		<u>\$36,435.93</u>
		Transactions		
Department 09 - CFRD				
Program 090000 - Main				
Account 52420 - Other Supplies				
8541 - Amazon.com Sales, INC (Amazon.com Services LLC)	09-Popcorn Bags-500 ct-CFRD Programs & Events		02/16/2024	33.29
Account 52420 - Other Supplies Totals		Invoice 1		<u>\$33.29</u>
		Transactions		
Account 53160 - Instruction				
3560 - First Financial Bank / Credit Cards	09-Chamber of Commerce Event-Inspire-Tickets for 7 CFRD Staff		02/16/2024	105.00
Account 53160 - Instruction Totals		Invoice 1		<u>\$105.00</u>
		Transactions		
Account 53910 - Dues and Subscriptions				
3560 - First Financial Bank / Credit Cards	09-Constant Contact Monthly Subscription Fee-January 2024		02/16/2024	145.00
Account 53910 - Dues and Subscriptions Totals		Invoice 1		<u>\$145.00</u>
		Transactions		
Program 090000 - Main Totals		Invoice 3		<u>\$283.29</u>
Department 09 - CFRD Totals		Transactions		
		Invoice 3		<u>\$283.29</u>
		Transactions		
Department 10 - Legal				
Program 100000 - Main				
Account 52410 - Books				
3956 - West Publishing Corporation (Thomson Reuters)	10-law booksl-Jan 2024- last payment -now online		02/16/2024	1,312.50
Account 52410 - Books Totals		Invoice 1		<u>\$1,312.50</u>
		Transactions		



Board of Public Works Claim Register

Invoice Date Range 02/03/24 - 02/16/24

Account 53120 - Special Legal Services

50587 - Barnes & Thornburg LLP	10-legal serv-general municipal advice-October 2023	02/16/2024	770.00
50587 - Barnes & Thornburg LLP	10-legal serv-general municipal advice-November 2023	02/16/2024	287.50
50587 - Barnes & Thornburg LLP	10-ARPA Compliance legal services December 2023	02/16/2024	2,988.50
50587 - Barnes & Thornburg LLP	10-legal serv-general municipal advice-December 2023	02/16/2024	307.50
19660 - Bose McKinney & Evans, LLP	10-annexation remonstrance legal serv-November 2023	02/16/2024	7,384.78
19660 - Bose McKinney & Evans, LLP	10-annexation remonstrance legal serv-November 2023	02/16/2024	23,355.81
19660 - Bose McKinney & Evans, LLP	10-legal services civic center John Waldron-December 2023	02/16/2024	490.00
Account 53120 - Special Legal Services Totals		Invoice 7	\$35,584.09
		Transactions	

Account 53220 - Postage

3560 - First Financial Bank / Credit Cards	10-shipping to Dentons FEDex5-982-41425	02/16/2024	33.09
Account 53220 - Postage Totals		Invoice 1	\$33.09
		Transactions	

Account 53910 - Dues and Subscriptions

3560 - First Financial Bank / Credit Cards	10- 2024 dues Indy bar -Pratt	02/16/2024	155.00
3956 - West Publishing Corporation (Thomson Reuters)	10-2024 Annual Westlaw Electronic Subscription	02/16/2024	22,966.27
Account 53910 - Dues and Subscriptions Totals		Invoice 2	\$23,121.27
		Transactions	

Account 53990 - Other Services and Charges

199 - Monroe County Government	10-January 2024 copies (3)	02/16/2024	3.00
Account 53990 - Other Services and Charges Totals		Invoice 1	\$3.00
		Transactions	
Program 100000 - Main Totals		Invoice 12	\$60,053.95
		Transactions	
Department 10 - Legal Totals		Invoice 12	\$60,053.95
		Transactions	

Department 11 - Mayor's Office

Program 110000 - Main



Board of Public Works Claim Register

Invoice Date Range 02/03/24 - 02/16/24

Account 47080 - Other Reimbursements

9147 - Carolyn Thomson	11-reimbursement for food for BPD Mtg-1/9/24	02/16/2024	59.00
Account 47080 - Other Reimbursements Totals		Invoice 1	\$59.00
		Transactions	

Account 52110 - Office Supplies

8541 - Amazon.com Sales, INC (Amazon.com Services LLC)	11-supplies for office; rcvd stamp , and in & out box travs. mul	02/16/2024	122.17
Account 52110 - Office Supplies Totals		Invoice 1	\$122.17
		Transactions	

Account 52420 - Other Supplies

129 - FedEx Print Service, INC (Printing Only)	11- sign for health clinic-Acct #0547243307	02/16/2024	61.28
4549 - Kroger Limited Partnership I	11 - flowers for employee health clinic opening		39.96
Account 52420 - Other Supplies Totals		Invoice 2	\$101.24
		Transactions	

Account 53170 - Mgt. Fee, Consultants, and Workshops

3560 - First Financial Bank / Credit Cards	11- Our Choice Gala-fee-Mayor Thomson	02/16/2024	150.00
Account 53170 - Mgt. Fee, Consultants, and Workshops Totals		Invoice 1	\$150.00
		Transactions	

Account 53230 - Travel

3560 - First Financial Bank / Credit Cards	11-hotel-Mayor Thomson- Washington DC-1/16-1/19/24	02/16/2024	1,138.63
Account 53230 - Travel Totals		Invoice 1	\$1,138.63
		Transactions	

Account 53910 - Dues and Subscriptions

6891 - Gatehouse Media Indiana Holdings	11-Herald Times digital + print annual subscription	02/16/2024	492.00
53442 - Paragon Micro, INC	11-Power BI Pro-software subscription-billed monthly-11/30/23	02/16/2024	9.16
Account 53910 - Dues and Subscriptions Totals		Invoice 2	\$501.16
		Transactions	

Account 53990 - Other Services and Charges

205 - City Of Bloomington	11-2024 Black History Month platinum sponsorship	02/16/2024	500.00
3560 - First Financial Bank / Credit Cards	11-Brevo marketing 01/10/24-01/30/24	02/16/2024	116.77



Board of Public Works Claim Register

Invoice Date Range 02/03/24 - 02/16/24

3560 - First Financial Bank / Credit Cards	11-Trello 11 users for 12/24/23-12/24/24	02/16/2024	1,319.89
3560 - First Financial Bank / Credit Cards	11-Trello 1 addtl user for 01/17/24-12/24/24	02/16/2024	112.43
3560 - First Financial Bank / Credit Cards	11-Namify-22 name tags for employees	02/16/2024	269.45
3560 - First Financial Bank / Credit Cards	11-Namify-20 name tags for employees	02/16/2024	222.70
9119 - Griffin Realty Holdings, LLC (Griffin Realty)	11 - real estate services for 220 E 3rd St sale	02/16/2024	11,250.00
6915 - David John Wild (Wild Consulting & Innovations, LLC)	11-Innovation-Digital analysis of welfare checks 2 of 2	02/16/2024	4,750.00
Account 53990 - Other Services and Charges Totals		Invoice 8	<u>\$18,541.24</u>
Program 110000 - Main Totals		Transactions Invoice 16	<u>\$20,613.44</u>
Department 11 - Mayor's Office Totals		Transactions Invoice 16	<u>\$20,613.44</u>
Department 12 - Human Resources		Transactions	
Program 120000 - Main			
Account 53320 - Advertising			
3560 - First Financial Bank / Credit Cards	12-Job Posting - Benefits Manager	02/16/2024	50.00
3560 - First Financial Bank / Credit Cards	12-Job Posting - Payroll Coordinator	02/16/2024	50.00
Account 53320 - Advertising Totals		Invoice 2	<u>\$100.00</u>
		Transactions	
Account 53990 - Other Services and Charges			
8882 - Employers Choice Online INC	12-out of state background checks (7)	02/16/2024	232.33
Account 53990 - Other Services and Charges Totals		Invoice 1	<u>\$232.33</u>
Program 120000 - Main Totals		Transactions Invoice 3	<u>\$332.33</u>
Department 12 - Human Resources Totals		Transactions Invoice 3	<u>\$332.33</u>
Department 13 - Planning		Transactions	
Program 130000 - Main			
Account 52110 - Office Supplies			



Board of Public Works Claim Register

Invoice Date Range 02/03/24 - 02/16/24

8541 - Amazon.com Sales, INC (Amazon.com Services LLC)	13- Hand Sanitizer Refill		02/16/2024	11.35
8541 - Amazon.com Sales, INC (Amazon.com Services LLC)	13- First aid kit, pens, legal pads, kleenex, and notebooks		02/16/2024	108.15
Account 52110 - Office Supplies Totals			Invoice 2 Transactions	<u>\$119.50</u>
Account 53630 - Machinery and Equipment Repairs				
2895 - Rapid Reproductions, INC	13- Repair of plotter machine printhead -12/19/23		02/16/2024	345.00
Account 53630 - Machinery and Equipment Repairs Totals			Invoice 1 Transactions	<u>\$345.00</u>
Account 53960 - Grants				
2002 - Boys & Girls Club Of Bloomington, INC	13- Local-Motion Grant Program		02/16/2024	2,400.00
234 - Monroe County Community School Corporation (MCCSC)	13- Local-Motion Grant Program		02/16/2024	2,400.00
64 - Monroe County Public Library	13- Local-Motion Grant Program		02/16/2024	1,200.00
10990 - (YMCA) Young Men's Christian Assoc of Monroe CO, INC	13- Local-Motion Grant Program		02/16/2024	1,200.00
Account 53960 - Grants Totals			Invoice 4 Transactions	<u>\$7,200.00</u>
Account 53990 - Other Services and Charges				
3663 - WSP USA, INC	3-Neighborhood Greenways 11/01/23-12/31/23	BC 2023-098	02/16/2024	28,939.90
6235 - Toole Design Group, LLC	13- Safe Streets & Roads-All Action Plan-thru 12/31/23	BC 2023-036	02/16/2024	15,005.68
Account 53990 - Other Services and Charges Totals			Invoice 2 Transactions	<u>\$43,945.58</u>
Program 130000 - Main Totals			Invoice 9 Transactions	<u>\$51,610.08</u>
Department 13 - Planning Totals			Invoice 9 Transactions	<u>\$51,610.08</u>
Department 19 - Facilities Maintenance				
Program 190000 - Main				
Account 52310 - Building Materials and Supplies				
8541 - Amazon.com Sales, INC (Amazon.com Services LLC)	19 - Sanding Discs, 6 in Self Adhesive Stickyback Sandpaper disc		02/16/2024	283.06
8541 - Amazon.com Sales, INC (Amazon.com Services LLC)	19 - Sanding belts		02/16/2024	344.40



Board of Public Works Claim Register

Invoice Date Range 02/03/24 - 02/16/24

8541 - Amazon.com Sales, INC (Amazon.com Services LLC)	19- metal locking key cabinet for Facilities	02/16/2024	99.00
8541 - Amazon.com Sales, INC (Amazon.com Services LLC)	19 - Car battery jump starter	02/16/2024	303.96
413 - Bloomington Paint & Wallpaper Co	19 - paint for engineering dept remodel	02/16/2024	105.78
413 - Bloomington Paint & Wallpaper Co	19 - paint for engineering dept remodel	02/16/2024	158.67
651 - Engraving & Stamp Center, INC	19 - nameplates for City Hall	02/16/2024	23.83
177 - Indiana Oxygen Company, INC	19 - gases for various tools	02/16/2024	44.40
4574 - John Deere Financial f.s.b. (Rural King)	19-3 boxes of shop rags & 10 Drum liners	02/16/2024	235.87
395 - Kirby Risk Corp	19 - 5 in/6 in baffle led module	02/16/2024	14.29
395 - Kirby Risk Corp	19- Opening black wallplate, 20 cubic in work z for city hall	02/16/2024	41.36
8658 - Kleindorfer's Hardware LLC	19 -light bulbs, dowel rods, scraper, keys made, corner brackets	02/16/2024	94.49
8658 - Kleindorfer's Hardware LLC	19 - bracket rods, floor slides, brackets, Binge cords	02/16/2024	96.75
8658 - Kleindorfer's Hardware LLC	19 - trim screws, mattock handle & head, thermostat, door sweep	02/16/2024	146.06
8658 - Kleindorfer's Hardware LLC	19 - pikstiks, gloves, cable ties, private property signs, fans	02/16/2024	192.34
8658 - Kleindorfer's Hardware LLC	19 - jersey gloves, pliers, vise grip, screwdrivers, diag cutter	02/16/2024	217.71
Account 52310 - Building Materials and Supplies Totals		Invoice 16 Transactions	\$2,401.97
Account 52340 - Other Repairs and Maintenance			
8541 - Amazon.com Sales, INC (Amazon.com Services LLC)	19 - drill bits & scwdriver bits for impact driver power tool	02/16/2024	43.96
8541 - Amazon.com Sales, INC (Amazon.com Services LLC)	19 - Compact tool storage tote, moisture meter, tool baa	02/16/2024	88.58
8541 - Amazon.com Sales, INC (Amazon.com Services LLC)	19 - Winter Gloves for Brighten Btown Crew	02/16/2024	127.60
8541 - Amazon.com Sales, INC (Amazon.com Services LLC)	19 - Winter Gloves for Brighten Btown Crew	02/16/2024	175.45
Account 52340 - Other Repairs and Maintenance Totals		Invoice 4 Transactions	\$435.59
Account 52420 - Other Supplies			
8541 - Amazon.com Sales, INC (Amazon.com Services LLC)	19- Pole Mounted Metal Dog Waste Receptacle	02/16/2024	135.64



Board of Public Works Claim Register

Invoice Date Range 02/03/24 - 02/16/24

8541 - Amazon.com Sales, INC (Amazon.com Services LLC)	19-Project Mgmt. Guide		02/16/2024	149.96
	Account 52420 - Other Supplies Totals	Invoice 2		<u>\$285.60</u>
Account 52430 - Uniforms and Tools		Transactions		
19171 - Aramark Uniform & Career Apparel Group, INC	19 - Pants for R Flake - 1/25/2024		02/16/2024	12.41
	Account 52430 - Uniforms and Tools Totals	Invoice 1		<u>\$12.41</u>
Account 53510 - Electrical Services		Transactions		
223 - Duke Energy	02-Facilities Summary-FS#4 bill-11/30/23-01/02/24		02/07/2024	10,839.26
	Account 53510 - Electrical Services Totals	Invoice 1		<u>\$10,839.26</u>
Account 53610 - Building Repairs		Transactions		
6299 - Bounds Flooring, INC	19 - SA repair carpet in OOTC-C. Gilliland Office	BC 2023-066	02/16/2024	215.00
321 - Harrell Fish, INC (HFI)	19-SA-City Hall-Quarterly Planned Maintenance-Jan 2024	BC 2023-074	02/16/2024	2,088.00
6688 - SSW Enterprises, LLC (Office Pride)	19- SA Jan 2024 Cleaining Services at Animal Care & Control		02/16/2024	2,572.55
6688 - SSW Enterprises, LLC (Office Pride)	19- SA Jan 2024 Cleaining Services at City Hall		02/16/2024	14,308.80
6688 - SSW Enterprises, LLC (Office Pride)	19- SA Jan 2024 Cleaining Services at Fleet Maint garage		02/16/2024	1,123.98
6688 - SSW Enterprises, LLC (Office Pride)	19- SA Jan 2024 Cleaning Services at Sanitation		02/16/2024	1,087.68
6688 - SSW Enterprises, LLC (Office Pride)	19- SA Jan 2024 Cleaining Services at Street & Traffic		02/16/2024	1,745.92
	Account 53610 - Building Repairs Totals	Invoice 7		<u>\$23,141.93</u>
	Program 190000 - Main Totals	Transactions		
	Department 19 - Facilities Maintenance Totals	Invoice 31		<u>\$37,116.76</u>
		Transactions		
		Invoice 31		<u>\$37,116.76</u>
		Transactions		
Department 28 - ITS				
Program 280000 - Main				
Account 53160 - Instruction				
3560 - First Financial Bank / Credit Cards	28- Humanitix - Brader Digital Equity Conference Fee		02/16/2024	474.00



Board of Public Works Claim Register

Invoice Date Range 02/03/24 - 02/16/24

Account 53230 - Travel

3560 - First Financial Bank / Credit Cards

28- Southwest-Brader Flight-Digital Equity-PA-2/12-2/16/24

Invoice 1 Transactions \$474.00

02/16/2024 797.96

Account 53230 - Travel Totals

Invoice 1 Transactions \$797.96

Account 53640 - Hardware and Software Maintenance

5534 - Presidio Holdings, INC

28 - 25 Network AP Licenses

02/16/2024 3,793.50

5534 - Presidio Holdings, INC

28- Back up Switches & Firewall

02/16/2024 1,487.26

5534 - Presidio Holdings, INC

28-Back up Switches & Firewall

02/16/2024 2,478.68

Account 53640 - Hardware and Software Maintenance Totals

Invoice 3 Transactions \$7,759.44

Account 53910 - Dues and Subscriptions

6870 - Carahsoft Technology Corporation

28-LinkedIn Annual Subscription Renewal-3/26/24-3/25/25

02/16/2024 3,696.00

3560 - First Financial Bank / Credit Cards

28- BlueSky - Zoom Timer Subscription 1/4/24

02/16/2024 89.95

3560 - First Financial Bank / Credit Cards

28- ConnectWise - Annual Endpoint & Remote Access 2024

02/16/2024 660.00

3560 - First Financial Bank / Credit Cards

28-Google - Website & Application APIs & Domains-Jan 2024

02/16/2024 24.21

3560 - First Financial Bank / Credit Cards

28- Google - Website & Application APIs & Domains 2024

02/16/2024 262.86

3560 - First Financial Bank / Credit Cards

28-Ninite - 2024 Pro Renewal for 1000 Machines

02/16/2024 2,220.00

3560 - First Financial Bank / Credit Cards

28-Parted Magic - quarterly subscription 1/13/24

02/16/2024 13.00

3560 - First Financial Bank / Credit Cards

28-Submittable - Application Sub Software 01/27/24-02/27/24

02/16/2024 119.00

3560 - First Financial Bank / Credit Cards

28-Zoom-Subscriptions & Storage Fees 01/20/24-02/19/24

02/16/2024 430.00

3560 - First Financial Bank / Credit Cards

28-Domain-bloomigtonplanroom.com-1 year renewal-1/27/24

02/16/2024 12.00

8441 - Promevo Holdings, INC (Promevo, LLC)

28- Google Enterprise & gPanel Renewal & Archive 2024

02/16/2024 34.50

Account 53910 - Dues and Subscriptions Totals

Invoice 11 Transactions \$7,561.52

Program 280000 - Main Totals

Invoice 16 Transactions \$16,592.92



Board of Public Works Claim Register

Invoice Date Range 02/03/24 -

02/16/24

Department **28 - ITS** Totals
Fund **101 - General Fund (S0101)** Totals

Invoice 16	\$16,592.92
Transactions	
Invoice 175	\$874,551.74
Transactions	

Fund **153 - LIT – Economic Development**

Department **04 - Economic & Sustainable Dev**

Program **040000 - Main**

Account **53960 - Grants**

19922 - Center For Sustainable Living, INC	04-SEEL Energy Efficiency Grant- (611 W. 12th St)	02/16/2024	10,000.00
3560 - First Financial Bank / Credit Cards	04- Table Sponsor/Member Reg-Btn Women in Leadership	02/16/2024	530.00
9094 - David Brent Johnson	04: Public Art Grant - David Brent Johnson	02/16/2024	500.00
8550 - Veregy IN, LLC	04-Solar Repairs & Inverter Replacements-T&M Dillman WWTP	02/16/2024	1,748.44
8550 - Veregy IN, LLC	04-Solar Repairs & Inverter Replacements-T&M Arrav/Tiao Ontin	02/16/2024	3,562.74
8550 - Veregy IN, LLC	04-Solar Repairs & Inverter Replacements-Frank Southern Ctr	02/16/2024	8,215.10
8550 - Veregy IN, LLC	04-Solar Repairs & Inverter Replacements-T&M Services	02/16/2024	12,500.00
9137 - Sarah Caroyrn Welsh	04-Public Art Grant - Sarah Welsh	02/16/2024	1,000.00

Account **53960 - Grants** Totals Invoice 8 \$38,056.28

Transactions Invoice 8 \$38,056.28

Program **040000 - Main** Totals

Transactions Invoice 8 \$38,056.28

Department **04 - Economic & Sustainable Dev** Totals

Transactions

Department **19 - Facilities Maintenance**

Program **190000 - Main**

Account **53990 - Other Services and Charges**

421 - Centerstone Of Indiana, INC	02-Brighten B-Town Program-December 2023	BC 2023-001	02/16/2024	30,649.99
421 - Centerstone Of Indiana, INC	02 - Dec 2023 Vehicle expense (Lease through May 2024)		02/16/2024	649.00
4483 - City Lawn Corporation	19-SA-4th & WASHINGTON for 10/10 & 10/25/2023	BC 2023-073	02/16/2024	60.00



Board of Public Works Claim Register

Invoice Date Range 02/03/24 - 02/16/24

Account 53990 - Other Services and Charges Totals	Invoice 3	\$31,358.99
Program 190000 - Main Totals	Transactions Invoice 3	\$31,358.99
Department 19 - Facilities Maintenance Totals	Transactions Invoice 3	\$31,358.99
Department 28 - ITS	Transactions	
Program 280000 - Main		
Account 53980 - Community Access TV/Radio		
64 - Monroe County Public Library	28-Cable Access Television Serv (CATS)-Jan-March 2024 BC 2023-083 02/16/2024	116,242.25
Account 53980 - Community Access TV/Radio Totals	Invoice 1	\$116,242.25
Program 280000 - Main Totals	Transactions Invoice 1	\$116,242.25
Department 28 - ITS Totals	Transactions Invoice 1	\$116,242.25
Fund 153 - LIT - Economic Development Totals	Transactions Invoice 12	\$185,657.52
Fund 176 - ARPA Local Fiscal Recvry (S9512)	Transactions	
Department 04 - Economic & Sustainable Dev		
Program G21005 - ARPA COVID Local Fiscal Recovery		
Account 53960 - Grants		
7532 - Christina Elem	04-Consulting Services for public art- 01/02/24-01/16/24 02/16/2024	928.00
Account 53960 - Grants Totals	Invoice 1	\$928.00
Program G21005 - ARPA COVID Local Fiscal Recovery Totals	Transactions Invoice 1	\$928.00
Department 04 - Economic & Sustainable Dev Totals	Transactions Invoice 1	\$928.00
Department 07 - Engineering	Transactions	
Program G21005 - ARPA COVID Local Fiscal Recovery		
Account 54310 - Improvements Other Than Building		
5149 - E&B Paving, INC	07-Release Bd Held Retainage-West Allen Street Greenwav (CN) BC 2022-123 02/16/2024	14,503.50



Board of Public Works Claim Register

Invoice Date Range 02/03/24 -

02/16/24

Account 54310 - Improvements Other Than Building Totals	Invoice 1	\$14,503.50
Program G21005 - ARPA COVID Local Fiscal Recovery Totals	Transactions	
Department 07 - Engineering Totals	Invoice 1	\$14,503.50
Fund 176 - ARPA Local Fiscal Recvry (S9512) Totals	Transactions	
	Invoice 1	\$14,503.50
	Transactions	
	Invoice 2	\$15,431.50
	Transactions	
Fund 249 - Grants Non Approp		
Department 07 - Engineering		
Program G21017 - Comcast Fountain Dr		
Account 47250 - Grant - Other		
204 - State Of Indiana	15-B-Line Extension Local Match (CN) R-40293-A, Des 1700735	02/07/2024 32,000.00
	Account 47250 - Grant - Other Totals	Invoice 1 \$32,000.00
	Program G21017 - Comcast Fountain Dr Totals	Transactions
	Department 07 - Engineering Totals	Invoice 1 \$32,000.00
	Fund 249 - Grants Non Approp Totals	Transactions
		Invoice 1 \$32,000.00
		Transactions
Fund 312 - Community Services		
Department 09 - CFRD		
Program 090002 - Com Serv - MLK Comm		
Account 52420 - Other Supplies		
3560 - First Financial Bank / Credit Cards	09-Sam's Club-Mini Bottles of Water for 2024 MLK Event	02/16/2024 23.94
	Account 52420 - Other Supplies Totals	Invoice 1 \$23.94
		Transactions
Account 53990 - Other Services and Charges		
3560 - First Financial Bank / Credit Cards	09-Hilton Garden Inn-Jesse Hagopian Stay-MLK 2024	02/16/2024 108.00
7096 - Institute for Democratic Ed & Culture (SpeakOut)	09-Hagopian Speaker/Food/Travel Fees-MLK Jr. Birthday Event 2024	02/16/2024 4,660.42
	Account 53990 - Other Services and Charges Totals	Invoice 2 \$4,768.42
		Transactions



Board of Public Works Claim Register

Invoice Date Range 02/03/24 - 02/16/24
 Invoice 3 \$4,792.36

Program **090016 - Com Serv - Safe & Civil**

Account **52420 - Other Supplies**

4549 - Kroger Limited Partnership I	09-2 Gallons of Tea-Black History Month Kickoff	02/16/2024	6.58
5819 - Synchrony Bank	09-Mini Cheesecakes, Cookies, Brownies-Event Food	02/16/2024	61.86
11693 - The Award Center, INC	09-BHM Visionary Leader Awards 2024-2 Laser-Engraved Awards	02/16/2024	140.00
6284 - VTG Enterprises, LLC (PopKorn)	09-Black History Month Popkorn-80 bags-for Kickoff Guests	02/16/2024	100.00

Account **52420 - Other Supplies** Totals Invoice 4 \$308.44
 Transactions

Account **53990 - Other Services and Charges**

3560 - First Financial Bank / Credit Cards	09-Safe & Civil City Jotform-1/23-2/23/24-Act 1-mosss	02/16/2024	19.00
3560 - First Financial Bank / Credit Cards	09-Elfsight Subscription-BHM 2024 Online Calendar Embed Tech	02/16/2024	24.00
3560 - First Financial Bank / Credit Cards	09-Safe & Civil City Jotform-1/29-2/29/24-Acct 2-safeandcivil	02/16/2024	19.00

Account **53990 - Other Services and Charges** Totals Invoice 3 \$62.00
 Transactions

Program **090016 - Com Serv - Safe & Civil** Totals Invoice 7 \$370.44
 Transactions

Department **09 - CFRD** Totals Invoice 10 \$5,162.80
 Transactions

Fund **312 - Community Services** Totals Invoice 10 \$5,162.80
 Transactions

Fund **401 - Non-Reverting Telecom (S1146)**

Department **25 - Telecommunications**

Program **254000 - Infrastructure**

Account **53640 - Hardware and Software Maintenance**

13482 - Northern Lights Locating & Inspection, INC	25- BDU Line Locates-After Hrs Emergency Call Out-1/31/24	02/16/2024	200.00
--	---	------------	--------

Account **53640 - Hardware and Software Maintenance** Totals Invoice 1 \$200.00
 Transactions

Account **54310 - Improvements Other Than Building**



Board of Public Works Claim Register

Invoice Date Range 02/03/24 - 02/16/24

8541 - Amazon.com Sales, INC (Amazon.com Services LLC)	28-6 Server Adapters	02/16/2024	41.85
Account 54310 - Improvements Other Than Building Totals		Invoice 1	<u>\$41.85</u>
Program 254000 - Infrastructure Totals		Transactions Invoice 2	<u>\$241.85</u>
Program 256000 - Services		Transactions	
Account 53150 - Communications Contract			
203 - INDIANA UNIVERSITY	28-Fire Station Dark Fiber Service January 2024	02/16/2024	65.00
Account 53150 - Communications Contract Totals		Invoice 1	<u>\$65.00</u>
Account 54450 - Equipment		Transactions	
8541 - Amazon.com Sales, INC (Amazon.com Services LLC)	28 - CAPR Clerk Laptop Bag	02/16/2024	39.99
8541 - Amazon.com Sales, INC (Amazon.com Services LLC)	28-Monitor Enterprise Apps Team CapR	02/16/2024	119.99
8541 - Amazon.com Sales, INC (Amazon.com Services LLC)	28-CAPR Stock Peripherals-USB hub, keyboard & mouse combos. nowe	02/16/2024	1,919.25
Account 54450 - Equipment Totals		Invoice 3	<u>\$2,079.23</u>
Program 256000 - Services Totals		Transactions Invoice 4	<u>\$2,144.23</u>
Department 25 - Telecommunications Totals		Transactions Invoice 6	<u>\$2,386.08</u>
Fund 401 - Non-Reverting Telecom (S1146) Totals		Transactions Invoice 6	<u>\$2,386.08</u>
Fund 450 - Local Road and Street(S0706)		Transactions	
Department 20 - Street			
Program 200000 - Main			
Account 53520 - Street Lights / Traffic Signals			
223 - Duke Energy	02-Street Light (Misc Lights)-11/30/23-01/02/24	02/07/2024	3,589.88
223 - Duke Energy	02-Street Light (Misc Lights)-11/30/23-01/02/24	02/07/2024	1,772.61
223 - Duke Energy	02-Street Light (Misc Lights)-11/29/23-12/27/23	02/07/2024	1,180.87
223 - Duke Energy	02-Street Light (Misc Lights)-11/30/23-12/28/23	02/07/2024	6,870.20



Board of Public Works Claim Register

Invoice Date Range 02/03/24 - 02/16/24

223 - Duke Energy	02-Street Light (Misc Lights)-11/30/23-12/28/23	02/07/2024	972.39
223 - Duke Energy	02-Street Light (Misc Lights)-11/30/23-12/28/23	02/07/2024	1,216.08
223 - Duke Energy	02-Street Light (Misc Lights)-11/30/23-12/28/23	02/07/2024	736.70
223 - Duke Energy	02-Street Light (Misc Lights)-11/30/23-12/29/23	02/07/2024	427.56
223 - Duke Energy	02-Street Light (Misc Lights)-11/30/23-01/03/24	02/07/2024	670.01
223 - Duke Energy	02-Street Light (Misc Lights)-11/30/23-01/08/24	02/07/2024	527.94
223 - Duke Energy	02-Street Light (Misc Lights)-11/30/23-01/02/24	02/07/2024	416.17
Account 53520 - Street Lights / Traffic Signals Totals		Invoice 11	<u>\$18,380.41</u>
		Transactions	
Program 200000 - Main Totals		Invoice 11	<u>\$18,380.41</u>
		Transactions	
Department 20 - Street Totals		Invoice 11	<u>\$18,380.41</u>
		Transactions	
Fund 450 - Local Road and Street(S0706) Totals		Invoice 11	<u>\$18,380.41</u>
		Transactions	
Fund 451 - Motor Vehicle Highway(S0708)			
Department 20 - Street			
Program 200000 - Main			
Account 52110 - Office Supplies			
8541 - Amazon.com Sales, INC (Amazon.com Services LLC)	20-Dry Erase Calendar Board for Sidewalk Supervisor	02/16/2024	39.99
Account 52110 - Office Supplies Totals		Invoice 1	<u>\$39.99</u>
		Transactions	
Account 52210 - Institutional Supplies			
313 - Fastenal Company	20-Safety Supplies for Crews-gloves	02/16/2024	151.78
Account 52210 - Institutional Supplies Totals		Invoice 1	<u>\$151.78</u>
		Transactions	
Account 52240 - Fuel and Oil			
7854 - Premier AG CO-OP, INC (Premier Energy)	20-K1 Kerosene Clear for Hot Box (282 gallons)-12/11/23	02/16/2024	1,175.66
Account 52240 - Fuel and Oil Totals		Invoice 1	<u>\$1,175.66</u>
		Transactions	



Board of Public Works Claim Register

Invoice Date Range 02/03/24 - 02/16/24

Account 52420 - Other Supplies

3560 - First Financial Bank / Credit Cards	20-Supplies for Snow Control Crews Street/Fleet	02/16/2024	201.12
50594 - Barry Company, INC	20-Brine machine parts (true unions)	02/16/2024	62.89
409 - Black Lumber Co. INC	20-Tie down ratchet truck #4221	02/16/2024	19.96
409 - Black Lumber Co. INC	20-(2) bleach, (2) back saver sprayer for brine tank	02/16/2024	67.96
409 - Black Lumber Co. INC	20-Contractor hose & thumb pro nozzle for brine tank	02/16/2024	55.98
409 - Black Lumber Co. INC	20-(2) 128 oz bleach for brine tank	02/16/2024	13.98
409 - Black Lumber Co. INC	20-quikrete concrete gravel for Tavin Oaks Ridge	02/16/2024	7.99
409 - Black Lumber Co. INC	20-8PK litium battery for traffic building	02/16/2024	26.99
177 - Indiana Oxygen Company, INC	20-Propane for thermal cart	02/16/2024	169.65
4574 - John Deere Financial f.s.b. (Rural King)	20-Ratchet Straps for Unit #410	02/16/2024	59.97
8658 - Kleindorfer's Hardware LLC	20-Lucas Int. Detailer, Micfber towels, concrete duster for snow	02/16/2024	31.77
8658 - Kleindorfer's Hardware LLC	20-Flat. Alum. for snow control	02/16/2024	8.69
8658 - Kleindorfer's Hardware LLC	20-Supplies for Brine Machine-pvc cement, spigot adapter	02/16/2024	10.77
8658 - Kleindorfer's Hardware LLC	20-(3) shelf brackets, rubber glvoes	02/16/2024	33.16
8658 - Kleindorfer's Hardware LLC	20-25 ft 5/16 grd 70 ch, (2) 51 16 gcd 70 hook	02/16/2024	106.98
786 - Richard's Small Engine, INC	20-Helmet wheel suspensions & chain for tree crew	02/16/2024	88.77

Account **52420 - Other Supplies** Totals

Invoice 16 Transactions

\$966.63

Account 53160 - Instruction

3560 - First Financial Bank / Credit Cards	20-IAA 2024 Membership & Conference Fee for Sean McCov	02/16/2024	423.38
--	--	------------	--------

Account **53160 - Instruction** Totals

Invoice 1 Transactions

\$423.38

Account 53250 - Paggers

332 - Indiana Paging Network, INC	20-Pagers for Snow Control Crews March 2024	02/16/2024	111.48
-----------------------------------	---	------------	--------



Board of Public Works Claim Register

Invoice Date Range 02/03/24 - 02/16/24

		Account 53250 - Pagers Totals	Invoice 1	\$111.48
			Transactions	
Account 53410 - Liability / Casualty Premiums				
19618 - ONI Risk Partners, INC, DBA EPIC Insurance Midwest	12-Insurance Premium 01/01/24-01/01/25		02/16/2024	85,322.20
19618 - ONI Risk Partners, INC, DBA EPIC Insurance Midwest	12-Property Insurance Premium 01/01/24-01/01/25		02/16/2024	1,589.08
19618 - ONI Risk Partners, INC, DBA EPIC Insurance Midwest	12-Crime Renewal Insurance Premium 01/01/24-01/01/25		02/16/2024	50.93
19618 - ONI Risk Partners, INC, DBA EPIC Insurance Midwest	12-Excess Liability Insurance Premium 01/01/24-01/01/25		02/16/2024	769.48
19618 - ONI Risk Partners, INC, DBA EPIC Insurance Midwest	12-Excess Workers Comp Insurance Premium 01/01/24-01/01/25		02/16/2024	2,170.82
		Account 53410 - Liability / Casualty Premiums Totals	Invoice 5	\$89,902.51
			Transactions	
Account 53510 - Electrical Services				
223 - Duke Energy	02-Facilities Summary-FS#4 bill-11/30/23-01/02/24		02/07/2024	437.08
		Account 53510 - Electrical Services Totals	Invoice 1	\$437.08
			Transactions	
Account 53910 - Dues and Subscriptions				
3560 - First Financial Bank / Credit Cards	20-Sam's Club Membership for PW 2024		02/16/2024	95.00
2871 - International Municipal Signal Association (IMSA)	20-2024 Membership Dues for IMSA (Carroll & Morris)		02/16/2024	170.00
		Account 53910 - Dues and Subscriptions Totals	Invoice 2	\$265.00
			Transactions	
Account 53920 - Laundry and Other Sanitation Services				
19171 - Aramark Uniform & Career Apparel Group, INC	20-uniform rental (minus payroll ded)-1/24/24		02/16/2024	8.35
19171 - Aramark Uniform & Career Apparel Group, INC	20-mat/towel service-1/24/2024		02/16/2024	38.47
19171 - Aramark Uniform & Career Apparel Group, INC	20-uniform rental (minus payroll ded)-1/31/2024		02/16/2024	8.35
19171 - Aramark Uniform & Career Apparel Group, INC	20-mat/towel service-1/31/24		02/16/2024	38.47
		Account 53920 - Laundry and Other Sanitation Services Totals	Invoice 4	\$93.64
			Transactions	
Account 53990 - Other Services and Charges				
19444 - Jeffery D Todd (Todd Septic Tank Service)	20-Pump Salt Water Collection Tanks 01/12/24		02/16/2024	225.00



Board of Public Works Claim Register

Invoice Date Range 02/03/24 - 02/16/24

Account **53990 - Other Services and Charges** Totals
 Program **200000 - Main** Totals
 Department **20 - Street** Totals
 Fund **451 - Motor Vehicle Highway(S0708)** Totals

Invoice 1	\$225.00
Transactions	
Invoice 34	\$93,792.15
Transactions	
Invoice 34	\$93,792.15
Transactions	
Invoice 34	\$93,792.15
Transactions	

Fund **452 - Parking Facilities(S9502)**

Department **26 - Parking**

Program **260000 - Main**

Account **43160 - Lot/Garage Leases - Annual**

Peter Lanscioni
 26-Chose wrong garage, cancelled after one month, was charged 2
 Account **43160 - Lot/Garage Leases - Annual** Totals

02/16/2024	110.00
Invoice 1	\$110.00
Transactions	

Account **52210 - Institutional Supplies**

293 - J&S Locksmith Shop, INC
 26-copies of keys-Trades & 4th St garages (6)
 Account **52210 - Institutional Supplies** Totals

02/16/2024	21.00
Invoice 1	\$21.00
Transactions	

Account **52310 - Building Materials and Supplies**

8658 - Kleindorfer's Hardware LLC
 26-(2) keys & pad lock for server box at 4th St. Garage
 8658 - Kleindorfer's Hardware LLC
 26-(3) Locks for bike lockers
 8658 - Kleindorfer's Hardware LLC
 26-(4) can of air duster for parking equipment
 Account **52310 - Building Materials and Supplies** Totals

02/16/2024	11.49
02/16/2024	31.47
02/16/2024	31.96
Invoice 3	\$74.92
Transactions	

Account **53410 - Liability / Casualty Premiums**

19618 - ONI Risk Partners, INC, DBA EPIC Insurance Midwest
 12-Insurance Premium 01/01/24-01/01/25
 19618 - ONI Risk Partners, INC, DBA EPIC Insurance Midwest
 12-Crime Renewal Insurance Premium 01/01/24-01/01/25
 19618 - ONI Risk Partners, INC, DBA EPIC Insurance Midwest
 12-Excess Liability Insurance Premium 01/01/24-01/01/25
 19618 - ONI Risk Partners, INC, DBA EPIC Insurance Midwest
 12-Excess Workers Comp Insurance Premium 01/01/24-01/01/25

02/16/2024	4,185.94
02/16/2024	19.27
02/16/2024	624.14
02/16/2024	1,760.80



Board of Public Works Claim Register

Invoice Date Range 02/03/24 - 02/16/24

Account 53410 - Liability / Casualty Premiums Totals		Invoice 4	\$6,590.15
		Transactions	
Account 53510 - Electrical Services			
223 - Duke Energy	26-Walnut St Garage-300 N Walnut-elec chgs 12/02/23-01/02/24	02/07/2024	1,162.08
Account 53510 - Electrical Services Totals		Invoice 1	\$1,162.08
		Transactions	
Account 53630 - Machinery and Equipment Repairs			
8934 - Sierra Heating and Cooling LLC	26-4th St Gar-changed cassette blower motor in HVAC	02/16/2024	200.00
Account 53630 - Machinery and Equipment Repairs Totals		Invoice 1	\$200.00
		Transactions	
Account 53640 - Hardware and Software Maintenance			
3397 - Evens Time, INC	26-Walnut St Gar-wrong rate chg-updated rate files-10/6/23	02/16/2024	306.00
Account 53640 - Hardware and Software Maintenance Totals		Invoice 1	\$306.00
		Transactions	
Account 53840 - Lease Payments			
512 - 7th & Walnut , LLC	26-Walnut St Garage- March 2024 garage rent	02/16/2024	17,824.79
3887 - Mercury Development Group, LLC	26-Morton St Garage-March 2024 garage rent	02/16/2024	38,035.85
Account 53840 - Lease Payments Totals		Invoice 2	\$55,860.64
		Transactions	
Account 53940 - Temporary Contractual Employee			
1420 - Richard Trinkle (Trinkle SnowPlowing LLC)	26-Surface Lots 1-5-plowing/ice melt-1/13-1/19/2024	BC 2022-104 02/16/2024	4,640.00
Account 53940 - Temporary Contractual Employee Totals		Invoice 1	\$4,640.00
		Transactions	
Account 53990 - Other Services and Charges			
6688 - SSW Enterprises, LLC (Office Pride)	26-Parking Services office cleaning- 02/01/24	02/16/2024	100.00
Account 53990 - Other Services and Charges Totals		Invoice 1	\$100.00
		Transactions	
Program 260000 - Main Totals		Invoice 16	\$69,064.79
		Transactions	
Department 26 - Parking Totals		Invoice 16	\$69,064.79
		Transactions	
Fund 452 - Parking Facilities(S9502) Totals		Invoice 16	\$69,064.79
		Transactions	



Board of Public Works Claim Register

Invoice Date Range 02/03/24 - 02/16/24

Fund 454 - Alternative Transport(S6301)

Department **26 - Parking**

Program **260000 - Main**

Account **53990 - Other Services and Charges**

6688 - SSW Enterprises, LLC (Office Pride)	26-Parking Services office cleaning- 02/01/24	02/16/2024	77.40
	Account 53990 - Other Services and Charges Totals	Invoice 1	<u>\$77.40</u>
	Program 260000 - Main Totals	Transactions Invoice 1	<u>\$77.40</u>
	Department 26 - Parking Totals	Transactions Invoice 1	<u>\$77.40</u>
	Fund 454 - Alternative Transport(S6301) Totals	Transactions Invoice 1	<u>\$77.40</u>
		Transactions	

Fund 455 - Parking Meter Fund(S2141)

Department **26 - Parking**

Program **260000 - Main**

Account **52110 - Office Supplies**

6530 - Office Depot, INC	26-calculator for parking services	02/16/2024	14.99
	Account 52110 - Office Supplies Totals	Invoice 1	<u>\$14.99</u>
		Transactions	

Account 53410 - Liability / Casualty Premiums

19618 - ONI Risk Partners, INC, DBA EPIC Insurance Midwest	12-Insurance Premium 01/01/24-01/01/25	02/16/2024	4,185.94
19618 - ONI Risk Partners, INC, DBA EPIC Insurance Midwest	12-Crime Renewal Insurance Premium 01/01/24-01/01/25	02/16/2024	19.27
19618 - ONI Risk Partners, INC, DBA EPIC Insurance Midwest	12-Excess Liability Insurance Premium 01/01/24-01/01/25	02/16/2024	624.15
19618 - ONI Risk Partners, INC, DBA EPIC Insurance Midwest	12-Excess Workers Comp Insurance Premium 01/01/24-01/01/25	02/16/2024	1,760.81
	Account 53410 - Liability / Casualty Premiums Totals	Invoice 4	<u>\$6,590.17</u>
		Transactions	

Account **53990 - Other Services and Charges**

6688 - SSW Enterprises, LLC (Office Pride)	26-Parking Services office cleaning- 02/01/24	02/16/2024	309.60
--	---	------------	--------



Board of Public Works Claim Register

Invoice Date Range 02/03/24 - 02/16/24

Account 53990 - Other Services and Charges Totals	Invoice 1	\$309.60
	Transactions	
Program 260000 - Main Totals	Invoice 6	\$6,914.76
	Transactions	
Department 26 - Parking Totals	Invoice 6	\$6,914.76
	Transactions	
Fund 455 - Parking Meter Fund(S2141) Totals	Invoice 6	\$6,914.76
	Transactions	

Fund **456 - MVH Restricted**

Department **20 - Street**

Program **200000 - Main**

Account **52330 - Street , Alley, and Sewer Material**

334 - Irving Materials, INC	20-Concrete for Sidewalk Projects-1912 E. Kensington Ct	BC 2023-008	02/16/2024	660.00
334 - Irving Materials, INC	20-Concrete for Sidewalk Projects-530 S. College Mall Rd	BC 2023-008	02/16/2024	494.00
	Account 52330 - Street , Alley, and Sewer Material Totals	Invoice 2		\$1,154.00
		Transactions		
	Program 200000 - Main Totals	Invoice 2		\$1,154.00
		Transactions		
	Department 20 - Street Totals	Invoice 2		\$1,154.00
		Transactions		
	Fund 456 - MVH Restricted Totals	Invoice 2		\$1,154.00
		Transactions		

Fund **519 - 2016 GO Bonds Bond #2 (S0182)**

Department **06 - Controller's Office**

Program **060000 - Main**

Account **53810 - Principal**

5232 - The Huntington National Bank	06-General Obligation Bond Series 2016A-02/15/2024		02/07/2024	40,000.00
5232 - The Huntington National Bank	06-General Obligation Bond Series 2016B-02/15/2024		02/07/2024	15,000.00
5232 - The Huntington National Bank	06-General Obligation Bond Series 2016D-02/15/2024		02/07/2024	25,000.00
5232 - The Huntington National Bank	06-General Obligation Bond Series 2016E-02/15/2024		02/07/2024	65,000.00
5232 - The Huntington National Bank	06-General Obligation Bond Series 2016F-02/15/2024		02/07/2024	20,000.00



Board of Public Works Claim Register

Invoice Date Range 02/03/24 - 02/16/24

5232 - The Huntington National Bank	06-General Obligation Bond Series 2016G-02/15/2024	02/07/2024	80,000.00
5232 - The Huntington National Bank	06-General Obligation Bond Series 2016H-02/15/2024	02/07/2024	10,000.00
Account 53810 - Principal Totals		Invoice 7	<u>\$255,000.00</u>
		Transactions	
Account 53820 - Interest			
5232 - The Huntington National Bank	06-General Obligation Bond Series 2016A-02/15/2024	02/07/2024	22,950.00
5232 - The Huntington National Bank	06-General Obligation Bond Series 2016B-02/15/2024	02/07/2024	26,962.50
5232 - The Huntington National Bank	06-General Obligation Bond Series 2016C-02/15/2024	02/07/2024	39,493.75
5232 - The Huntington National Bank	06-General Obligation Bond Series 2016D-02/15/2024	02/07/2024	13,050.00
5232 - The Huntington National Bank	06-General Obligation Bond Series 2016E-02/15/2024	02/07/2024	22,043.75
5232 - The Huntington National Bank	06-General Obligation Bond Series 2016F-02/15/2024	02/07/2024	6,368.75
5232 - The Huntington National Bank	06-General Obligation Bond Series 2016G-02/15/2024	02/07/2024	9,587.50
5232 - The Huntington National Bank	06-General Obligation Bond Series 2016H-02/15/2024	02/07/2024	5,943.75
Account 53820 - Interest Totals		Invoice 8	<u>\$146,400.00</u>
		Transactions	
Program 060000 - Main Totals		Invoice 15	<u>\$401,400.00</u>
		Transactions	
Department 06 - Controller's Office Totals		Invoice 15	<u>\$401,400.00</u>
		Transactions	
Fund 519 - 2016 GO Bonds Bond #2 (S0182) Totals		Invoice 15	<u>\$401,400.00</u>
		Transactions	
Fund 520 - 2016 Parks GO Bond #3 (S0183)			
Department 06 - Controller's Office			
Program 060000 - Main			
Account 53810 - Principal			
5232 - The Huntington National Bank	06-Park District Bond Series 2016A-2/15/2024	02/07/2024	45,000.00
5232 - The Huntington National Bank	06-Park District Bond Series 2016B-2/15/2024	02/07/2024	20,000.00
5232 - The Huntington National Bank	06-Park District Bond Series 2016C-02/15/2024	02/07/2024	25,000.00



Board of Public Works Claim Register

Invoice Date Range 02/03/24 - 02/16/24

5232 - The Huntington National Bank	06-Park District Bond Series 2016D-02/15/2024	02/07/2024	35,000.00
5232 - The Huntington National Bank	06-Park District Bond Series 2016E-02/15/2024	02/07/2024	45,000.00
Account 53810 - Principal Totals		Invoice 5	<u>\$170,000.00</u>
		Transactions	
Account 53820 - Interest			
5232 - The Huntington National Bank	06-Park District Bond Series 2016A-2/15/2024	02/07/2024	23,400.00
5232 - The Huntington National Bank	06-Park District Bond Series 2016B-2/15/2024	02/07/2024	10,006.25
5232 - The Huntington National Bank	06-Park District Bond Series 2016C-02/15/2024	02/07/2024	13,196.88
5232 - The Huntington National Bank	06-Park District Bond Series 2016D-02/15/2024	02/07/2024	18,215.63
5232 - The Huntington National Bank	06-Park District Bond Series 2016E-02/15/2024	02/07/2024	23,640.63
Account 53820 - Interest Totals		Invoice 5	<u>\$88,459.39</u>
		Transactions	
Program 060000 - Main Totals		Invoice 10	<u>\$258,459.39</u>
		Transactions	
Department 06 - Controller's Office Totals		Invoice 10	<u>\$258,459.39</u>
		Transactions	
Fund 520 - 2016 Parks GO Bond #3 (S0183) Totals		Invoice 10	<u>\$258,459.39</u>
		Transactions	
Fund 522 - 2018 Parks Bicentennial (S1380)			
Department 06 - Controller's Office			
Program 060000 - Main			
Account 53810 - Principal			
5232 - The Huntington National Bank	06-Park District Bonds, Series 2018A-2/15/2024	02/07/2024	65,000.00
5232 - The Huntington National Bank	06-Park District Bonds, Series 2018B-2/15/2024	02/07/2024	75,000.00
5232 - The Huntington National Bank	06-Park District Bonds, Series 2018C-2/15/2024	02/07/2024	65,000.00
Account 53810 - Principal Totals		Invoice 3	<u>\$205,000.00</u>
		Transactions	
Account 53820 - Interest			
5232 - The Huntington National Bank	06-Park District Bonds, Series 2018A-2/15/2024	02/07/2024	57,500.00



Board of Public Works Claim Register

Invoice Date Range 02/03/24 - 02/16/24

5232 - The Huntington National Bank	06-Park District Bonds, Series 2018B-2/15/2024	02/07/2024	65,150.00
5232 - The Huntington National Bank	06-Park District Bonds, Series 2018C-2/15/2024	02/07/2024	39,940.63
	Account 53820 - Interest Totals	Invoice 3	<u>\$162,590.63</u>
	Program 060000 - Main Totals	Transactions Invoice 6	<u>\$367,590.63</u>
	Department 06 - Controller's Office Totals	Transactions Invoice 6	<u>\$367,590.63</u>
	Fund 522 - 2018 Parks Bicentennial (\$1380) Totals	Transactions Invoice 6	<u>\$367,590.63</u>
		Transactions	
Fund 526 - 2022 Parks GO Bond(Park Bond #2)			
Department 06 - Controller's Office			
Program 060000 - Main			
Account 53810 - Principal			
8795 - Regions Capital Advantage	06-Park District Bonds, Series 2022-2/15/24	02/07/2024	495,000.00
	Account 53810 - Principal Totals	Invoice 1	<u>\$495,000.00</u>
		Transactions	
Account 53820 - Interest			
8795 - Regions Capital Advantage	06-Park District Bonds, Series 2022-2/15/24	02/07/2024	63,114.00
	Account 53820 - Interest Totals	Invoice 1	<u>\$63,114.00</u>
	Program 060000 - Main Totals	Transactions Invoice 2	<u>\$558,114.00</u>
	Department 06 - Controller's Office Totals	Transactions Invoice 2	<u>\$558,114.00</u>
	Fund 526 - 2022 Parks GO Bond(Park Bond #2) Totals	Transactions Invoice 2	<u>\$558,114.00</u>
		Transactions	
Fund 527 - 2022 GO Bonds (Bond #4)			
Department 06 - Controller's Office			
Program 060000 - Main			
Account 53810 - Principal			
8795 - Regions Capital Advantage	06-City of Bloomington Go Bond-2/15/24	02/07/2024	495,000.00



Board of Public Works Claim Register

Invoice Date Range 02/03/24 - 02/16/24
 Invoice 1 \$495,000.00

Account **53820 - Interest**

8795 - Regions Capital Advantage

06-City of Bloomington Go Bond-2/15/24

Invoice 1
Transactions

02/07/2024 63,114.00

Account **53820 - Interest** Totals

Invoice 1
Transactions

\$63,114.00

Program **060000 - Main** Totals

Invoice 2
Transactions

\$558,114.00

Department **06 - Controller's Office** Totals

Invoice 2
Transactions

\$558,114.00

Fund **527 - 2022 GO Bonds (Bond #4)** Totals

Invoice 2
Transactions

\$558,114.00

Fund **601 - Cumulative Capital Devlp(S2391)**

Department **02 - Public Works**

Program **020000 - Main**

Account **52330 - Street , Alley, and Sewer Material**

18168 - Family Farm Supply, INC

20-Clear Lane De-icing Salt 01/31/24

02/16/2024 78,980.17

19278 - Milestone Contractors, LP

20-Asphalt for patching 01/30/24

BC 2023-009B 02/16/2024 200.72

19278 - Milestone Contractors, LP

20-Asphalt for patching 01/30/24

BC 2023-009B 02/16/2024 133.81

Account **52330 - Street , Alley, and Sewer Material** Totals

Invoice 3
Transactions

\$79,314.70

Program **020000 - Main** Totals

Invoice 3
Transactions

\$79,314.70

Department **02 - Public Works** Totals

Invoice 3
Transactions

\$79,314.70

Department **07 - Engineering**

Program **070000 - Main**

Account **54310 - Improvements Other Than Building**

3444 - Rundell Ernstberger Associates, INC

07-On-Call Engineering Serv-thru 12/31/23

BC 2023-043 02/16/2024 113.75

Account **54310 - Improvements Other Than Building** Totals

Invoice 1
Transactions

\$113.75

Program **070000 - Main** Totals

Invoice 1
Transactions

\$113.75



Board of Public Works Claim Register

Invoice Date Range 02/03/24 - 02/16/24

Department 07 - Engineering Totals	Invoice 1	\$113.75
Fund 601 - Cumulative Capital Devlp(S2391) Totals	Transactions	
	Invoice 4	\$79,428.45
	Transactions	

Fund **730 - Solid Waste (S6401)**

Department **16 - Sanitation**

Program **160000 - Main**

Account **52420 - Other Supplies**

3560 - First Financial Bank / Credit Cards	16 - Supplies during snow event	02/16/2024	48.14
48 - Continental Research Corporation	16-perma seal tape, air fresheners for trucks	02/16/2024	528.00
48 - Continental Research Corporation	16-air fresheners for restrooms-2 dozen	02/16/2024	489.16
48 - Continental Research Corporation	16-Truck Spill Kits (4)	02/16/2024	209.28
1743 - The Home City Ice Company	16-Ice for employees-73 7lb bags	02/16/2024	209.40

Account 52420 - Other Supplies Totals	Invoice 5	\$1,483.98
	Transactions	

Account **52430 - Uniforms and Tools**

793 - Indiana Safety Company, INC	16-brown jersey gloves for employees	02/16/2024	185.06
793 - Indiana Safety Company, INC	16-gauge palm coated knit gloves for employees	02/16/2024	456.12

Account 52430 - Uniforms and Tools Totals	Invoice 2	\$641.18
	Transactions	

Account **53140 - Exterminator Services**

51538 - Economy Termite & Pest Control, INC	16-Sanitation-montly pest control-12/27/23	BC 2023-070	02/16/2024	125.00
51538 - Economy Termite & Pest Control, INC	16 - Exterminator services for Sanitation 1-22-2024	BC 2023-070	02/16/2024	125.00

Account 53140 - Exterminator Services Totals	Invoice 2	\$250.00
	Transactions	

Account **53150 - Communications Contract**

5465 - Emergency Radio Service LLC (ERS-OCI Wireless)	16-antenna's for radios	02/16/2024	82.30
---	-------------------------	------------	-------

Account 53150 - Communications Contract Totals	Invoice 1	\$82.30
	Transactions	



Board of Public Works Claim Register

Invoice Date Range 02/03/24 - 02/16/24

Account 53240 - Freight / Other

48 - Continental Research Corporation	16-perma seal tape, air fresheners for trucks	02/16/2024	42.72
Account 53240 - Freight / Other Totals			Invoice 1 Transactions \$42.72

Account 53310 - Printing

7815 - A&M Graphics (Baugh Fine Print and Mailing)	16-50 -Non-Collection Notice Books (inc s/h)	02/16/2024	1,828.33
Account 53310 - Printing Totals			Invoice 1 Transactions \$1,828.33

Account 53410 - Liability / Casualty Premiums

19618 - ONI Risk Partners, INC, DBA EPIC Insurance Midwest	12-Insurance Premium 01/01/24-01/01/25	02/16/2024	56,235.55
19618 - ONI Risk Partners, INC, DBA EPIC Insurance Midwest	12-Property Insurance Premium 01/01/24-01/01/25	02/16/2024	1,508.81
19618 - ONI Risk Partners, INC, DBA EPIC Insurance Midwest	12-Crime Renewal Insurance Premium 01/01/24-01/01/25	02/16/2024	33.04
19618 - ONI Risk Partners, INC, DBA EPIC Insurance Midwest	12-Excess Liability Insurance Premium 01/01/24-01/01/25	02/16/2024	3,317.62
19618 - ONI Risk Partners, INC, DBA EPIC Insurance Midwest	12-Excess Workers Comp Insurance Premium 01/01/24-01/01/25	02/16/2024	9,359.49
8189 - Paragon Asset Recovery Services, LLC (Sedgwick)	16-Kathleen Mills Accident -12/4/23-#4A23124M71K (Wolford)	02/16/2024	5,000.00
Account 53410 - Liability / Casualty Premiums Totals			Invoice 6 Transactions \$75,454.51

Account 53510 - Electrical Services

223 - Duke Energy	02-Facilities Summary-FS#4 bill-11/30/23-01/02/24	02/07/2024	48.67
Account 53510 - Electrical Services Totals			Invoice 1 Transactions \$48.67

Account 53920 - Laundry and Other Sanitation Services

19171 - Aramark Uniform & Career Apparel Group, INC	16-uniform rental (minus payroll ded)- 1/03/2024	02/16/2024	7.97
19171 - Aramark Uniform & Career Apparel Group, INC	16-Mat Services - 01/3/2024	02/16/2024	26.76
19171 - Aramark Uniform & Career Apparel Group, INC	16-uniform rental (minus payroll ded)- 1/24/2024	02/16/2024	7.97
19171 - Aramark Uniform & Career Apparel Group, INC	16-Mat Services - 01/24/2024	02/16/2024	26.76
Account 53920 - Laundry and Other Sanitation Services Totals			Invoice 4 Transactions \$69.46



Board of Public Works Claim Register

Invoice Date Range 02/03/24 - 02/16/24

Program 160000 - Main Totals	Invoice 23	\$79,901.15
Department 16 - Sanitation Totals	Transactions	
	Invoice 23	\$79,901.15
Fund 730 - Solid Waste (S6401) Totals	Transactions	
	Invoice 23	\$79,901.15
	Transactions	

Fund 800 - Risk Management(S0203)

Department 10 - Legal

Program 100000 - Main

Account 53410 - Liability / Casualty Premiums

19618 - ONI Risk Partners, INC, DBA EPIC Insurance Midwest	12-Insurance Premium 01/01/24-01/01/25	02/16/2024	2,641.66
19618 - ONI Risk Partners, INC, DBA EPIC Insurance Midwest	12-Crime Renewal Insurance Premium 01/01/24-01/01/25	02/16/2024	4.13
19618 - ONI Risk Partners, INC, DBA EPIC Insurance Midwest	12-Excess Liability Insurance Premium 01/01/24-01/01/25	02/16/2024	75.32
19618 - ONI Risk Partners, INC, DBA EPIC Insurance Midwest	12-Excess Workers Comp Insurance Premium 01/01/24-01/01/25	02/16/2024	212.48

Account 53410 - Liability / Casualty Premiums Totals	Invoice 4	\$2,933.59
Program 100000 - Main Totals	Transactions	
Department 10 - Legal Totals	Invoice 4	\$2,933.59
Fund 800 - Risk Management(S0203) Totals	Transactions	
	Invoice 4	\$2,933.59
	Transactions	

Fund 801 - Health Insurance Trust

Department 12 - Human Resources

Program 120000 - Main

Account 53990 - Other Services and Charges

3977 - Cigna Health & Life Insurance Company	12 - January 2024 Cigna Dental/Vision	02/16/2024	9,960.61
18539 - Life Insurance Company Of North America	12-February 2024, Bill Ref # 103094_02/02/2024	02/16/2024	3,906.00
8609 - LoCascio Hadden & Dennis, LLC (LHD Benefit Advisor)	12-near-site employer clinic support-February 2024	02/16/2024	2,600.00
17785 - The Howard E. Nyhart Company, INC	12-Nyhart Admin Fees (FSA, HSA, Wellness)-December 2023	02/16/2024	1,336.50



Board of Public Works Claim Register

Invoice Date Range 02/03/24 - 02/16/24
1,459.05

17785 - The Howard E. Nyhart Company, INC	12-Admin Fees (FSA, HSA, Wellness)-January 2024	02/16/2024	1,459.05
	Account 53990 - Other Services and Charges Totals	Invoice 5	<u>\$19,262.16</u>
Account 53990.1201 - Other Services and Charges Health Insurance			
17785 - The Howard E. Nyhart Company, INC	12-HSA ER Contributions City - Leyenbeck, Richey	02/07/2024	3,310.00
	Account 53990.1201 - Other Services and Charges Health Insurance Totals	Invoice 1	<u>\$3,310.00</u>
Account 53990.1278 - Other Services and Charges Disability LTD			
18539 - Life Insurance Company Of North America	12-February 2024, Bill Ref # 103094_02/02/2024	02/16/2024	10,471.20
	Account 53990.1278 - Other Services and Charges Disability LTD Totals	Invoice 1	<u>\$10,471.20</u>
	Program 120000 - Main Totals	Transactions	<u>\$33,043.36</u>
	Department 12 - Human Resources Totals	Invoice 7	<u>\$33,043.36</u>
	Fund 801 - Health Insurance Trust Totals	Transactions	<u>\$33,043.36</u>
		Invoice 7	<u>\$33,043.36</u>
		Transactions	
Fund 802 - Fleet Maintenance(S9500)			
Department 17 - Fleet Maintenance			
Program 170000 - Main			
Account 52110 - Office Supplies			
6530 - Office Depot, INC	17 - Steno pad holder	02/16/2024	25.99
6530 - Office Depot, INC	17 - black vertical file	02/16/2024	4.34
	Account 52110 - Office Supplies Totals	Invoice 2	<u>\$30.33</u>
Account 52230 - Garage and Motor Supplies			
50605 - Bauer Built, INC	17 - Disposal Fees for Wide base & light truck tires	02/16/2024	329.00
50605 - Bauer Built, INC	17 - 9 retread, metal stem truck, flow thru valve & mounted	02/16/2024	3,110.60
4693 - Monroe County Tire & Supply, INC	17 - LT245/75R17 goodyear wrangler tires for 876	02/16/2024	346.50
4693 - Monroe County Tire & Supply, INC	17 -LT265/70R18 Goodyear wrangler enforcer tire for 319	02/16/2024	203.09



Board of Public Works Claim Register

Invoice Date Range 02/03/24 - 02/16/24

4693 - Monroe County Tire & Supply, INC	17 -(4) P225/50R17 Firestone all season tires for 245	02/16/2024	513.20
4693 - Monroe County Tire & Supply, INC	17 - LT245/75R17 firestone tires for 420	02/16/2024	633.32
Account 52230 - Garage and Motor Supplies Totals		Invoice 6 Transactions	<u>\$5,135.71</u>
Account 52240 - Fuel and Oil			
613 - Hoosier Penn Oil Company, INC	17 - HP FS CK4 5W40 oil for stock (200 gallons)	02/16/2024	2,760.81
7854 - Premier AG CO-OP, INC (Premier Energy)	17-fuel-B5 PDX4 Clear Winter on Road (7,365 gallons)- BC 2023-105B	02/16/2024	22,916.93
7854 - Premier AG CO-OP, INC (Premier Energy)	17 - DEF - Diesel Exhaust Fluid (300 gallons)- 1/31/24 BC2023-105B	02/16/2024	717.00
Account 52240 - Fuel and Oil Totals		Invoice 3 Transactions	<u>\$26,394.74</u>
Account 52320 - Motor Vehicle Repair			
244 - Bloomington Ford, INC	17 - Hose for 629	02/16/2024	31.00
244 - Bloomington Ford, INC	17 - Kit for P127	02/16/2024	41.25
5481 - Bright Equipment, INC (Bobcat of Ellettsville)	17 - #469 hydraulic oil- 2 2.5 gallon	02/16/2024	173.58
941 - Central Indiana Truck Equipment Corporation	17 - 7" HD Monitor (4 ports) for 963	02/16/2024	755.77
941 - Central Indiana Truck Equipment Corporation	17 - eject cylinder 187" for 963	02/16/2024	3,905.50
5792 - Clark Truck Equipment Co., INC	17 - Gearcase LH, Shift FSM unit for 495	02/16/2024	593.00
594 - Curry Auto Center, INC	17 - credit for returned N-Valve (Inv 5111597)	02/16/2024	(55.39)
594 - Curry Auto Center, INC	17 - credit for returned (2) N-Gaskets(Inv 5112558)	02/16/2024	(84.97)
594 - Curry Auto Center, INC	17 - core credit from converter for 293 (Inv 5113439)	02/16/2024	(400.00)
594 - Curry Auto Center, INC	17 - SL-N-Housing & SL-N-Sensor for 296	02/16/2024	112.94
594 - Curry Auto Center, INC	17 - #293 sensors and convertors	02/16/2024	1,915.84
51827 - Fire Service, INC	17 - Siren brake assembly for 343	02/16/2024	263.80
796 - Interstate Battery System of Bloomington, INC	17 -batteries-MT-34, MTP-46/H6, MTP-65HD, MTP-96R	02/16/2024	1,009.92
4439 - JX Enterprises, INC	17 - V-Band Clamp for 4221	02/16/2024	12.59



Board of Public Works Claim Register

Invoice Date Range 02/03/24 - 02/16/24

4439 - JX Enterprises, INC	17-FITT-#8 45 FEMSWVL reuse	02/16/2024	55.98
4439 - JX Enterprises, INC	17 - cap for 950	02/16/2024	117.99
4439 - JX Enterprises, INC	17 - Coolant level w/OBD module for 431	02/16/2024	154.99
4439 - JX Enterprises, INC	17 - T/S Switch kits for 959/960	02/16/2024	331.98
4439 - JX Enterprises, INC	17 - Coolant level probe sensor, sensor jumper & module w/OBD	02/16/2024	348.98
4439 - JX Enterprises, INC	17 - Cab latch & level for crane carrier	02/16/2024	629.97
4439 - JX Enterprises, INC	17 - Def tank assembly 3/8" return line for 959	02/16/2024	1,660.99
4439 - JX Enterprises, INC	17 - credit for core charge -Inv #27341248P	02/16/2024	(297.73)
4439 - JX Enterprises, INC	17 - credit for returned Air STL tank-Inv #27339516P	02/16/2024	(664.99)
53385 - O'Reilly Automotive Stores, INC	17 - Cabin Filter for 1218	02/16/2024	11.89
53385 - O'Reilly Automotive Stores, INC	17 - Exhaust manifold gasket for 293	02/16/2024	20.48
53385 - O'Reilly Automotive Stores, INC	17 - Torque mount for Ford sedan	02/16/2024	52.24
53385 - O'Reilly Automotive Stores, INC	17 - Torque mount for ford sedan	02/16/2024	52.24
53385 - O'Reilly Automotive Stores, INC	17 - New CV shift for sedan (P127)	02/16/2024	106.29
53385 - O'Reilly Automotive Stores, INC	17 - Brake rotor and ABS sensor for 872(Ford ranger)	02/16/2024	220.48
53385 - O'Reilly Automotive Stores, INC	17 - Torque mount & magnum gas for sedan (T156)	02/16/2024	252.40
53385 - O'Reilly Automotive Stores, INC	17 - Axle shaft for 1204	02/16/2024	473.59
16069 - Palmer Trucks, INC	17 - #774 10 bolt clutch shift	02/16/2024	1,792.45
476 - Southern Indiana Parts, INC (Napa Auto Parts)	17 - various parts for the month of January 2024	02/16/2024	10,148.71
54351 - Sternberg, INC	17 - Transioner, adjuster & fan belt for 692	02/16/2024	331.07
54351 - Sternberg, INC	17 - tensioner for 692	02/16/2024	391.06
54351 - Sternberg, INC	17 -shoe kit, barke drums, core deposit	02/16/2024	1,000.64
622 - Truck Country of Indiana, INC (Stoops Freightliner)	17 - 3 deg M2 support for 4211	02/16/2024	116.08



Board of Public Works Claim Register

Invoice Date Range 02/03/24 - 02/16/24

622 - Truck Country of Indiana, INC (Stoops Freightliner)	17 - end yoke, nut for 4211	02/16/2024	131.42
7555 - VoMac Truck Sales & Service INC	17 -reman shoe, brake drum, wheel stud, nut & relay valve - 958	02/16/2024	1,707.41
2096 - West Side Tractor Sales CO.	17 - Hydraulic cylinder kit, tie rod and assembly - 653	02/16/2024	2,083.60
2096 - West Side Tractor Sales CO.	17 - bolt & o-ring for 4571	02/16/2024	209.75
8183 - XL Parts LLC (XL Parts/Dealer Service Warehouse)	17 - 12 Oil filter for inventory	02/16/2024	89.88
8183 - XL Parts LLC (XL Parts/Dealer Service Warehouse)	17 - Ignition Coil Assembly	02/16/2024	112.00
8183 - XL Parts LLC (XL Parts/Dealer Service Warehouse)	17 - Ignition Coil Assembly, spark plugs	02/16/2024	258.98
8183 - XL Parts LLC (XL Parts/Dealer Service Warehouse)	17 - 3 inch Nerf bars for 628	02/16/2024	349.99

Account **52320 - Motor Vehicle Repair** Totals

Invoice 45 Transactions

\$30,525.64

Account **52420 - Other Supplies**

409 - Black Lumber Co. INC	17 - carbide steel demon & thick metal, diablo steel demon	02/16/2024	91.97
313 - Fastenal Company	17-gloves and liners	02/16/2024	65.82
3560 - First Financial Bank / Credit Cards	17 - software update - (2) 1 year tech subscriptions	02/16/2024	800.00
3560 - First Financial Bank / Credit Cards	17 - food for snow control	02/16/2024	162.64
4918 - HELM, INC	17 - Ford IDS software renewal one year thru 2/2/25	02/16/2024	800.00
4046 - Heritage-Crystal Clean, INC	17 - solvent for parts cleaner - 30 gal	02/16/2024	374.32
6759 - Interclean Equipment, LLC	17 - car wash soap-Six 55 gallon containers	02/16/2024	4,691.59
4140 - Interstate All Battery Center of Bloomington, INC	17 - 5 battery packs for shop	02/16/2024	999.75
8658 - Kleindorfer's Hardware LLC	17 - (12) 1/4 20 cage nuts	02/16/2024	28.68
8658 - Kleindorfer's Hardware LLC	17 - (18) nuts for 467	02/16/2024	48.42
8181 - Lawson Products, INC	17-bolts, cable ties, washers, brass fittings, lug nuts, etc	02/16/2024	990.41
480 - Proveli, LLC (Hall Signs, INC)	17 - 10" circle magnetic custom decals (10)	02/16/2024	72.50
6216 - Terminal Supply, INC	17-drill bit sets, oxide sanding, flap discs	02/16/2024	366.57



Board of Public Works Claim Register

Invoice Date Range 02/03/24 - 02/16/24
 Invoice 13 \$9,492.67

Account 53130 - Medical

231 - IU Health OCC Health Services	17-F. Robinson-hearing test-12/28/23	02/16/2024	37.00
-------------------------------------	--------------------------------------	------------	-------

Account 53130 - Medical Totals	Invoice 1	\$37.00
	Transactions	

Account 53240 - Freight / Other

19681 - Southeastern Equipment Co, INC	17 - #598 -water pump	02/16/2024	102.44
--	-----------------------	------------	--------

Account 53240 - Freight / Other Totals	Invoice 1	\$102.44
	Transactions	

Account 53410 - Liability / Casualty Premiums

19618 - ONI Risk Partners, INC, DBA EPIC Insurance Midwest	12-Insurance Premium 01/01/24-01/01/25	02/16/2024	10,616.30
19618 - ONI Risk Partners, INC, DBA EPIC Insurance Midwest	12-Property Insurance Premium 01/01/24-01/01/25	02/16/2024	1,475.22
19618 - ONI Risk Partners, INC, DBA EPIC Insurance Midwest	12-Crime Renewal Insurance Premium 01/01/24-01/01/25	02/16/2024	12.39
19618 - ONI Risk Partners, INC, DBA EPIC Insurance Midwest	12-Excess Liability Insurance Premium 01/01/24-01/01/25	02/16/2024	1,041.50
19618 - ONI Risk Partners, INC, DBA EPIC Insurance Midwest	12-Excess Workers Comp Insurance Premium 01/01/24-01/01/25	02/16/2024	2,938.22

Account 53410 - Liability / Casualty Premiums Totals	Invoice 5	\$16,083.63
	Transactions	

Account 53510 - Electrical Services

223 - Duke Energy	02-Facilities Summary-FS#4 bill-11/30/23-01/02/24	02/07/2024	664.62
-------------------	---	------------	--------

Account 53510 - Electrical Services Totals	Invoice 1	\$664.62
	Transactions	

Account 53530 - Water and Sewer

208 - City Of Bloomington Utilities	17-Fleet Maint-water/sewer bill-January 2024		569.02
-------------------------------------	--	--	--------

Account 53530 - Water and Sewer Totals	Invoice 1	\$569.02
	Transactions	

Account 53610 - Building Repairs

321 - Harrell Fish, INC (HFI)	17-no heat SE side of bldg-replaced filters-12/15/23	BC 2023-074 02/16/2024	415.88
321 - Harrell Fish, INC (HFI)	17 - new air line for the oil crusher -1/10/24	02/16/2024	1,534.94



Board of Public Works Claim Register

Invoice Date Range 02/03/24 - 02/16/24
 Invoice 2 \$1,950.82

Account **53610 - Building Repairs** Totals

Invoice 2
 Transactions

Account **53620 - Motor Repairs**

4336 - American Eagle Auto Glass of Terre Haute, INC	17 - windshield replacement for 829	02/16/2024	275.00
244 - Bloomington Ford, INC	17 - #P130 alignment	02/16/2024	99.95
244 - Bloomington Ford, INC	17 - #P135 alignment	02/16/2024	114.94
244 - Bloomington Ford, INC	17-replace heater core, put in new coolant-Unit 942	02/16/2024	1,210.68
594 - Curry Auto Center, INC	17 - #250 outside repairs - oil change & cooling svstem/Belts	02/16/2024	930.99
3560 - First Financial Bank / Credit Cards	17 - External tailpipe for 4861	02/16/2024	95.00
4474 - Ken's Westside Service & Towing, LLC	17 - tow- Unit#4141 Chevrolet Silverado-1/25/24	02/16/2024	95.00
4474 - Ken's Westside Service & Towing, LLC	17 - tow-Ford F-450 Super Duty-Unit #616-1/25/24	02/16/2024	95.00
4474 - Ken's Westside Service & Towing, LLC	17 - tow- Ford F-450 Super Duty-Unit #874-1/25/24	02/16/2024	95.00
4474 - Ken's Westside Service & Towing, LLC	17 - tow bills for Ford F-550 Super Duty-Unit #463-1/19/24	02/16/2024	250.00
4474 - Ken's Westside Service & Towing, LLC	17-tow-International Workstar 7400 (dump truck)-1/23/24	02/16/2024	325.00
19681 - Southeastern Equipment Co, INC	17 - #598 -water pump	02/16/2024	3,287.06
54351 - Sternberg, INC	17 - service and diagnostics for 938	02/16/2024	695.58
54351 - Sternberg, INC	17 - 938 -maintenance services & parts	02/16/2024	706.60
622 - Truck Country of Indiana, INC (Stoops Freightliner	17 - #964 parts & labor to repair oil leak	02/16/2024	7,294.48

Account **53620 - Motor Repairs** Totals

Invoice 15
 Transactions

\$15,570.28

Account **53650 - Other Repairs**

7052 - Automotive Lift Repair, LLC	17 - repairs to in ground lifts	02/16/2024	1,025.65
8143 - Cummins INC dba Cummins Sales and Service	17 - planned maintenance for the generator-11/30/23	BC 2022-103 02/16/2024	346.78

Account **53650 - Other Repairs** Totals

Invoice 2
 Transactions

\$1,372.43

Account **53920 - Laundry and Other Sanitation Services**



Board of Public Works Claim Register

Invoice Date Range 02/03/24 - 02/16/24

19171 - Aramark Uniform & Career Apparel Group, INC	17 - City portion Of uniform rentals - 1/17/2024	02/16/2024	19.45
19171 - Aramark Uniform & Career Apparel Group, INC	17 - mat and towel rentals - 1/17/2024	02/16/2024	93.35
19171 - Aramark Uniform & Career Apparel Group, INC	17 - City portion Of uniform rentals - 1/31/2024	02/16/2024	20.41
19171 - Aramark Uniform & Career Apparel Group, INC	17 - mat rentals and shop towels-1/31/2024	02/16/2024	93.35
Account 53920 - Laundry and Other Sanitation Services Totals		Invoice 4	<u>\$226.56</u>
Account 53990 - Other Services and Charges		Transactions	
3560 - First Financial Bank / Credit Cards	17 - bmv fees	02/16/2024	15.00
3560 - First Financial Bank / Credit Cards	17 - bmv fees	02/16/2024	45.00
6891 - Gatehouse Media Indiana Holdings	17 - advertising for auction - 12/20/23	02/16/2024	28.91
Account 53990 - Other Services and Charges Totals		Invoice 3	<u>\$88.91</u>
Account 54420 - Purchase of Equipment		Transactions	
8403 - Brennan Equipment Services	17-Hyundai Forklift & Attachments	02/16/2024	35,714.00
Account 54420 - Purchase of Equipment Totals		Invoice 1	<u>\$35,714.00</u>
Program 170000 - Main Totals		Transactions	
Department 17 - Fleet Maintenance Totals		Invoice 105	<u>\$143,958.80</u>
Fund 802 - Fleet Maintenance(\$9500) Totals		Transactions	
		Invoice 105	<u>\$143,958.80</u>
		Transactions	
		Invoice 105	<u>\$143,958.80</u>
		Transactions	
Fund 804 - Insurance Voluntary Trust			
Department 12 - Human Resources			
Program 120000 - Main			
Account 53990.1241 - Other Services and Charges Vision			
3977 - Cigna Health & Life Insurance Company	12 - January 2024 Cigna Dental/Vision	02/16/2024	(123.42)
Account 53990.1241 - Other Services and Charges Vision Totals		Invoice 1	<u>(\$123.42)</u>
Account 53990.1271 - Other Services and Charges Section 125 - URM- City		Transactions	



Board of Public Works Claim Register

Invoice Date Range 02/03/24 - 02/16/24

17785 - The Howard E. Nyhart Company, INC	12-City/Util URM	02/05/2024	80.88
17785 - The Howard E. Nyhart Company, INC	12-City URM	02/05/2024	46.17
17785 - The Howard E. Nyhart Company, INC	12-City URM	02/06/2024	66.94
17785 - The Howard E. Nyhart Company, INC	12-City URM	02/07/2024	264.24
17785 - The Howard E. Nyhart Company, INC	12-City/Util URM	02/08/2024	558.85
Account 53990.1271 - Other Services and Charges Section 125 - URM- City Totals		Invoice 5	<u>\$1,017.08</u>
Account 53990.1273 - Other Services and Charges Term Life		Transactions	
18539 - Life Insurance Company Of North America	12-February 2024, Bill Ref # 103094_02/02/2024	02/16/2024	20,391.06
Account 53990.1273 - Other Services and Charges Term Life Totals		Invoice 1	<u>\$20,391.06</u>
Account 53990.1277 - Other Services and Charges Disability STD		Transactions	
18539 - Life Insurance Company Of North America	12-February 2024, Bill Ref # 103094_02/02/2024	02/16/2024	10,356.71
Account 53990.1277 - Other Services and Charges Disability STD Totals		Invoice 1	<u>\$10,356.71</u>
Account 53990.1281 - Other Services and Charges Section 125 - URM- Util		Transactions	
17785 - The Howard E. Nyhart Company, INC	12-City/Util URM	02/05/2024	90.00
17785 - The Howard E. Nyhart Company, INC	12-City/Util URM	02/08/2024	34.96
Account 53990.1281 - Other Services and Charges Section 125 - URM- Util Totals		Invoice 2	<u>\$124.96</u>
Account 53990.1283 - Other Services and Charges Health Savings Account		Transactions	
17785 - The Howard E. Nyhart Company, INC	12-HSA Employee Contributions 2-9-2024	02/08/2024	26,759.02
Account 53990.1283 - Other Services and Charges Health Savings Account Totals		Invoice 1	<u>\$26,759.02</u>
Program 120000 - Main Totals		Transactions	
Department 12 - Human Resources Totals		Invoice 11	<u>\$58,525.41</u>
Fund 804 - Insurance Voluntary Trust Totals		Transactions	
Grand Totals		Invoice 11	<u>\$58,525.41</u>
		Transactions	
		Invoice 11	<u>\$58,525.41</u>
		Transactions	
		Invoice 11	<u>\$58,525.41</u>
		Transactions	
		Invoice 465	<u>\$3,846,041.93</u>
		Transactions	