



Board of Public Works Staff Report

Project/Event: Natural Gas Line Pressure Testing and Retrofitting
Staff Representative: Kyle Baugh
Petitioner/Representative: York Little
Date: March 12th, 2024

Report: Ensite USA is requesting lane shifts in various areas (see plan for detailed locations) including N. Dunn St, S. Walnut St, S. High St, and N. Smith Rd. The traffic control would be in place from 6/1/24 through 10/11/24.

Ensite USA is also requesting a multi-use path closure on S. High St on the east side of the road. The traffic control would be in place for one week with exact timing to be specified at a later date.

This request is to accommodate retro-fitting and pressure testing of Citizen Energy's natural gas pipeline.

Ensite USA has supplied maintenance of traffic plans for all work. They have also sent Public notice to property owners about the BPW meeting and scope of their work (see packet for details).



February 26, 2024

Via Electronic Delivery

Board of Public Works
City of Bloomington
401 North Morton Street
Bloomington, IN 47404

Project No. 7604.5142 8" NS5153 Needmore to Unionville Pressure Test & Retrofit

Dear Board Members:

CenterPoint Energy is planning a maintenance project to perform pipeline maintenance activities on an existing 8-inch pipeline during 2024 within the jurisdictions of Monroe County and the City of Bloomington. The maintenance project begins near the intersection of S State Road 37 and S Old State Road 37 and extends north and northeast to approximately N. Mount Gilead Road.

In order to facilitate this project, CenterPoint is respectfully requesting the temporary closure of S High Street, just south of the intersection of E Rock Creek Drive, as well as the sidewalk along the east side of S High Street. Closures will be in accordance with the attached Maintenance of Traffic Plan. CenterPoint is requesting these partial lane closures to occur for a maximum of one week per lane from June 3rd, 2024 through September 27, 2024.

CenterPoint will coordinate with the City of Bloomington and City of Bloomington Utilities, law enforcement, and transit providers to assure that this restriction and closure information is well communicated. Therefore, CenterPoint respectfully requests that the Board of Public Works approves the restrictions closure referenced above from June 3rd, 2024 through September 27, 2024.

Kind Regards,

A handwritten signature in blue ink that reads "Dylan Garrison".

Dylan Garrison, PE
Senior Engineer
dgarrison@ensiteusa.com
(606) 813-6629

From: Bloomington Legals <publicnotice@heraldt.com>
Sent: Monday, February 26, 2024 11:17 AM
To: York Little
Subject: Thank you for placing your order with us.

THANK YOU for your ad submission!

This is your confirmation that your order has been submitted. Below are the details of your transaction. Please save this confirmation for your records.

We appreciate you using our online self-service ads portal, available 24/7. Please continue to visit Bloomington Herald Times's online Classifieds [HERE](#) to place your legal notices in the future.

Changes and/or cancellations may not be honored up to 2 business days prior to your first publication date.

Job Details Order Number: LSBN0066451 Classification: Public Notices Package: General Package Base amount: \$40.22 Service fee: \$1.60 Cash/Check/ACH ◆ Discount: -\$0.00 Total payment: \$41.82 As an incentive for customers, we provide a discount off the total order cost equal to the 3.99% service fee if you pay with Cash/Check/ACH. Pay by Cash/Check/ACH and save! In no event are service fees refundable. Payment Type: visa	Schedule for ad number LSBN00664510 Wed Feb 28, 2024 Bloomington Herald Times <i>All Zones</i>
Account Details York Little 1055 Wellington Way Suite 225 Lexington, KY ◆ 40513 859-967-7372 ylittle@ensiteusa.com EnSiteUSA, Inc. Credit Card - visa *****1690	

CenterPoint Energy Pipeline
Maintenance Project
CenterPoint Energy will
perform pipeline maintenance
activities on an existing 8-inch
pipeline during 2024 within the
jurisdictions of Monroe County
and the City of Bloomington.
The maintenance project
begins near the intersection
of S State Road 37 and S Old
State Road 37 and extends
north and northeast to approxi-
mately N Mount Gilead Road.
This maintenance project will
be reviewed during the Board
of Public Works meeting on
Tuesday, March 12, 2024.
HSPAXLP
Publication Dates
L00000000

CAUTION: External Email

This email originated from outside the organization. Please validate the sender's email address and do not click links or open attachments unless you recognize the sender and are expecting the message.

8" NS5153 NEEDMORE TO UNIONVILLE PRESSURE TEST & RETROFIT

HYDROTEST SECTIONS - LINE SUMMARY		
TEST SECTION	TEST LENGTH (LF)	FRAC TANKS REQ. (EA)
1	53,600	8

MAP LEGEND:

- HYDROTEST SECTION 1
- PIPELINE REPLACEMENT/ RE-ROUTE
- EXISTING PIPE

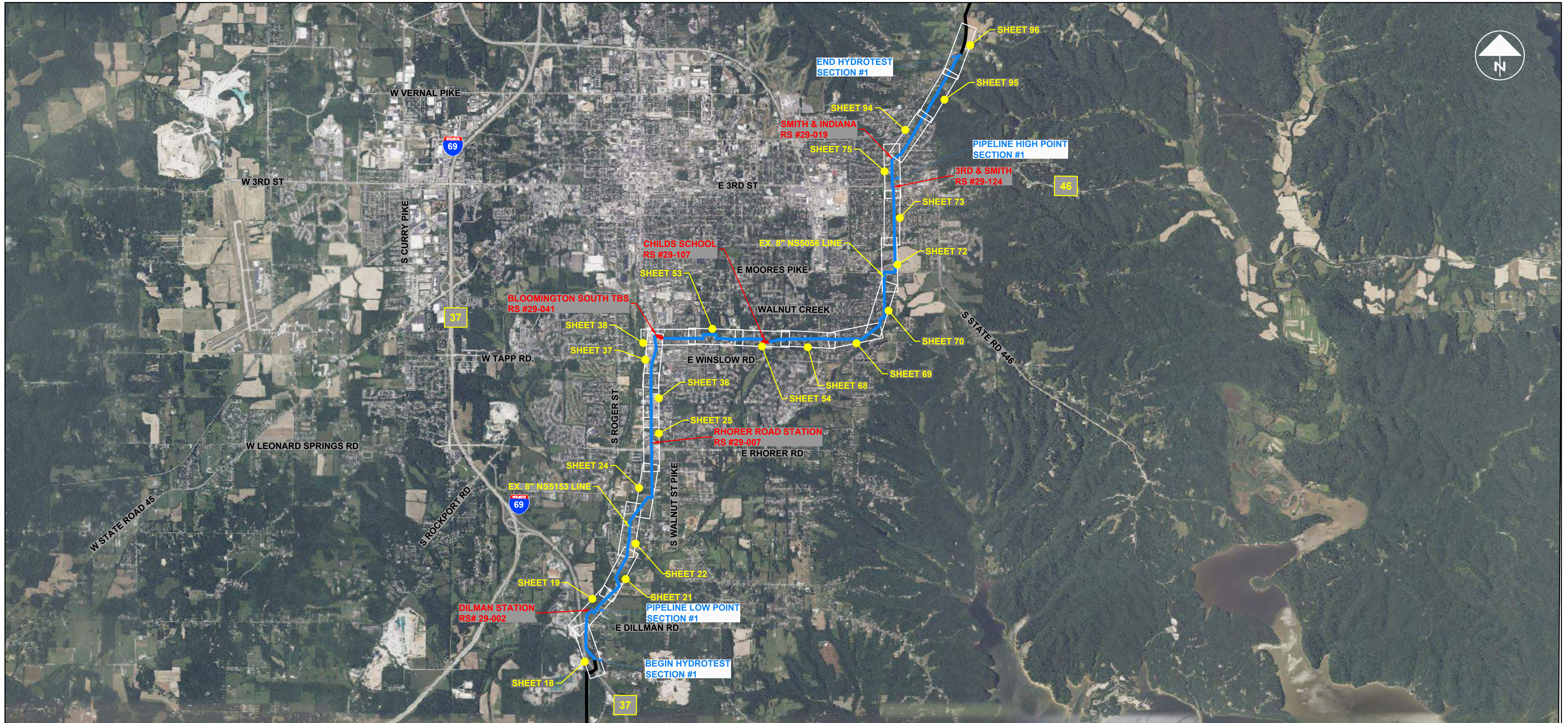

**GLOBAL, ALL SHEETS: CONFIRMED REVIEW
DATE W/ CNP IS TUESDAY, JANUARY 23, 2024.
PLEASE UPDATE ALL REV STAMPS/DATES.**

1/23/2024

**RE-ISSUED FOR REVIEW
NOT FOR CONSTRUCTION
1/17/2024**

**NOTE:
THE BEND ANGLE FOR FITTINGS HAS BEEN
ESTIMATED AND SHALL BE FIELD VERIFIED
BY CONTRACTOR.**

K:\7604-5142-8r-NS5056\Cover\7604-5142-0000\1102024-3-24-01 PM, Last Saved 1/17/2024 2:05:09 PM by DKESLING, Last Pnt 1/10/2024 3:24:01 PM by JESSICA LAMB



NOTE: DRAWINGS MAY HAVE BEEN ENLARGED OR REDUCED FROM THE ORIGINAL. THE GRAPHIC SCALE IS PROVIDED FOR REFERENCE.

REVISIONS			
NO.	DATE	BY	DESCRIPTION
B	07/24/2023	JCS	ISSUED FOR 60% REVIEW
C	9/8/2023	JCS	ISSUED FOR 90% REVIEW
0	10/17/2023	JCS	ISSUED FOR BID
D	1/17/2024	JCS	RE-ISSUED FOR REVIEW

OPERATING CENTER: BLOOMINGTON	DIVISION: VEDIN
PROJECT#: 7604.5142	SCALE: 1" = 3000'
CITY / TOWNSHIP: BLOOMINGTON	COUNTY: MONROE
STATE: IN	

8" NS5153 NEEDMORE TO UNIONVILLE PRESSURE TEST & RETROFIT GENERAL COVER		
EnSiteUSA DWG NO. 0000	SHEET NO. SHEET 1	REV. D



DISCLAIMER: ENSITEUSA MAKES NO GUARANTEE THAT THIS SURVEY OR THESE MAPS CONTAINS COMPLETE OR CONCLUSIVE UNDERGROUND OR ABOVEGROUND UTILITY INFORMATION. THE CONTRACTOR IS RESPONSIBLE FOR VERIFYING THE LOCATION & PRESERVATION OF ALL UNDERGROUND AND ABOVEGROUND UTILITIES WHETHER OR NOT DEPICTED ON THESE DRAWINGS. THE CONTRACTOR IS TO CONTACT ALL OWNERS OF UNDERGROUND AND ABOVEGROUND UTILITIES PRIOR TO ANY EXCAVATION.

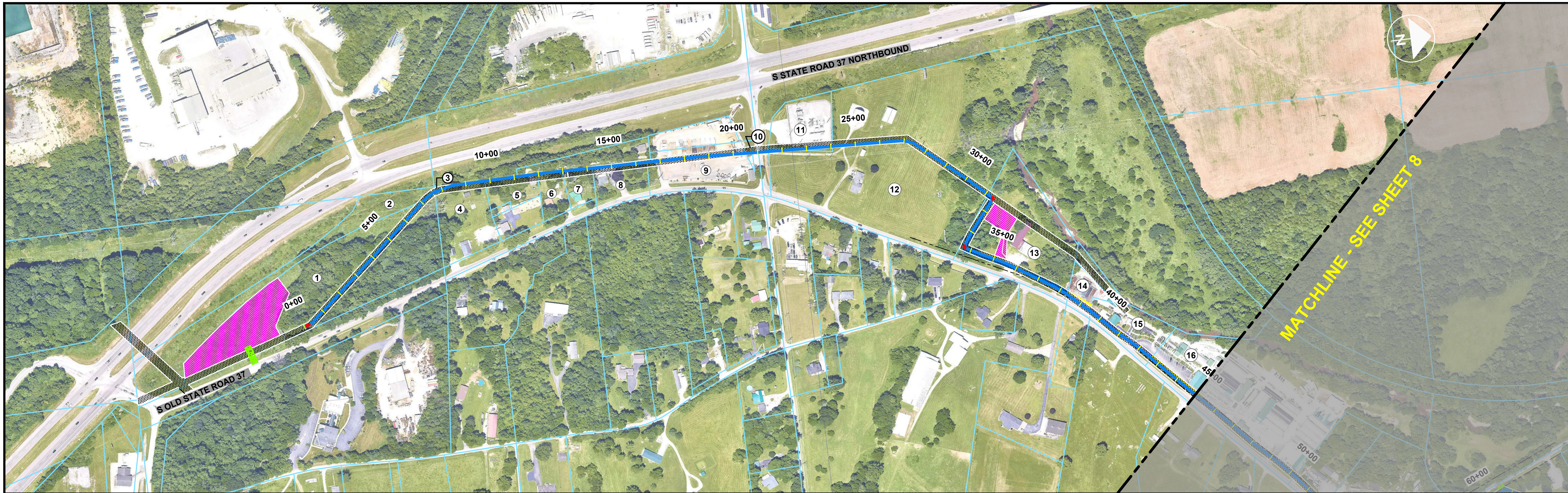

NUMBER	OWNER NAME	PARCEL ID	EXISTING EASEMENT	PROPOSED PERMANENT	PROPOSED TEMPORARY
1	ACACIA INVESTMENTS LLC	53-08-32-100-050.000-008	Y	N	Y
2	STATE OF INDIANA	53-08-32-100-043.000-008	Y	N	N
3	STATE OF INDIANA	53-08-32-100-033.000-008	Y	N	N
4	WEBB, ALBERT & MARGARET E	53-08-32-100-041.000-008	Y	N	N
5	GRUBB, KENNETH W. & DIANA L.	53-08-32-100-034.000-008	Y	N	N
6	GRUBB, KEVIN W	53-08-32-100-026.000-008	Y	N	N
7	IVERSON, MARY E	53-08-32-100-051.000-008	Y	N	N
8	LAWRENCE, JOHN W & CARRIE A	53-08-32-100-046.000-008	Y	N	N
9	JAMMS PROPERTIES LLC	53-08-32-100-052.000-008	Y	N	N
10	JAMMS PROPERTIES LLC	53-08-32-100-012.000-008	Y	N	N
11	PUBLIC SERVICE COMPANY	53-08-29-300-007.000-008	Y	N	N
12	MCKAMEY, JEFFREY	53-08-29-400-022.000-008	Y	N	N
13	BROWNFIELDS LLC	53-08-29-400-016.000-008	Y	N	Y
14	6522 SOUTH OLD STATE ROAD 37 LLC	53-08-29-400-038.000-008	Y	N	N
15	PENNINGTON, NATHANIEL C	53-08-29-400-021.000-008	Y	N	N
16	J & H MAY PROPERTIES LLC	53-08-29-400-029.000-008	Y	N	N

K:\7604-5142-8n-NS5056\0-Cover\7604-5142-0005\11022024-9-26-26 PM, Last Saved 11/16/2023 2:05:21 PM by DVEESLING, Last Plot 11/02/2024 3:36:28 PM by JESSICA LAMB

	RE-ISSUED FOR REVIEW NOT FOR CONSTRUCTION 1/X/2024	Know what's below. Call 811 before you dig.	 <small>NOTE: DRAWINGS MAY HAVE BEEN ENLARGED OR REDUCED FROM THE ORIGINAL. THE GRAPHIC SCALE IS PROVIDED FOR REFERENCE.</small>	REVISIONS		OPERATING CENTER: BLOOMINGTON	DIVISION: VEDIN	8" NS5153 NEEDMORE TO UNIONVILLE PRESSURE TEST & RETROFIT GENERAL PARCEL MAP																	
				<table border="1" style="width: 100%; border-collapse: collapse;"> <thead> <tr> <th style="width: 5%;">NO.</th> <th style="width: 10%;">DATE</th> <th style="width: 5%;">BY</th> <th style="width: 80%;">DESCRIPTION</th> </tr> </thead> <tbody> <tr> <td>A</td> <td>9/8/2023</td> <td>TMP</td> <td>ISSUED FOR 90% REVIEW</td> </tr> <tr> <td>0</td> <td>10/17/2023</td> <td>JCS</td> <td>ISSUED FOR BID</td> </tr> <tr> <td>0A</td> <td>10/31/2023</td> <td>JCS</td> <td>RE-ISSUED FOR BID</td> </tr> <tr> <td>B</td> <td>1/X/2024</td> <td>JCS</td> <td>RE-ISSUED FOR REVIEW</td> </tr> </tbody> </table>	NO.	DATE	BY	DESCRIPTION	A	9/8/2023		TMP	ISSUED FOR 90% REVIEW	0	10/17/2023	JCS	ISSUED FOR BID	0A	10/31/2023	JCS	RE-ISSUED FOR BID	B	1/X/2024	JCS	RE-ISSUED FOR REVIEW
NO.	DATE	BY	DESCRIPTION																						
A	9/8/2023	TMP	ISSUED FOR 90% REVIEW																						
0	10/17/2023	JCS	ISSUED FOR BID																						
0A	10/31/2023	JCS	RE-ISSUED FOR BID																						
B	1/X/2024	JCS	RE-ISSUED FOR REVIEW																						

DISCLAIMER: ENSITEUSA MAKES NO GUARANTEE THAT THIS SURVEY OR THESE MAPS CONTAINS COMPLETE OR CONCLUSIVE UNDERGROUND OR ABOVEGROUND UTILITY INFORMATION. THE CONTRACTOR IS RESPONSIBLE FOR VERIFYING THE LOCATION & PRESERVATION OF ALL UNDERGROUND AND ABOVEGROUND UTILITIES WHETHER OR NOT DEPICTED ON THESE DRAWINGS. THE CONTRACTOR IS TO CONTACT ALL OWNERS OF UNDERGROUND AND ABOVEGROUND UTILITIES PRIOR TO ANY EXCAVATION.

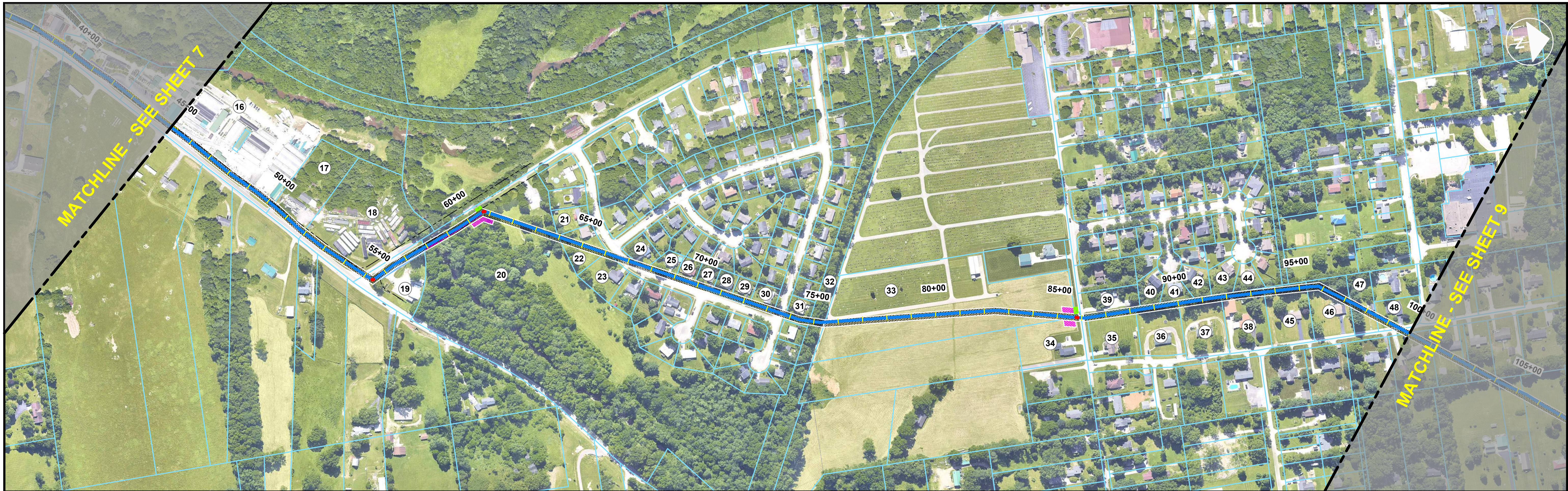

K:\7604-5142-8r-NS5060-Cover\7604-5142-000811\022024-2-26-2024-9:26:39 PM, Last Saved 11/16/2023 2:05:23 PM by DWEE/SLING, Last Plo 1/10/2024 3:26:39 PM by JESSICA LAMB

NUMBER	OWNER NAME	PARCEL ID	EXISTING EASEMENT	PROPOSED PERMANENT	PROPOSED TEMPORARY
16	J & H MAY PROPERTIES LLC	53-08-29-400-029.000-008	Y	N	N
17	DODGE, DANA L. & BETTY	53-08-29-400-025.000-008	Y	N	N
18	SHIELDS, ROBERT H & SALLY A	53-08-29-400-028.000-008	Y	N	N
19	KEEN, LEE R & SANDRA L	53-08-29-400-030.000-008	Y	N	N
20	MONROE COUNTY PARK & RECREATION BOARD	53-08-29-100-006.000-008	Y	N	Y
21	KERNAN, DAN	53-08-29-107-003.000-008	Y	N	N
22	FOUST, JOEL W & KIMBERLY A	53-08-29-107-005.000-008	Y	N	N
23	CHASTAIN, DOUGLAS R & REBECCA	53-08-29-107-002.000-008	Y	N	N
24	LUCASS, SHARON K	53-08-29-107-007.000-008	Y	N	N
25	REYNOLDS, MADONNA K.	53-08-29-107-011.000-008	Y	N	N
26	ANDERSON, LESLIE	53-08-29-101-009.000-008	Y	N	N
27	ARMSTRONG, AMANDA LEE; JOURDAN, MATTHEW CORY	53-08-29-101-016.000-008	Y	N	N
28	LONG, ANDREW D & ALANNA K	53-08-29-101-006.000-008	Y	N	N
29	MCGOVERN, JOSHUA J. & SARA B.	53-08-29-101-017.000-008	Y	N	N
30	DECKARD, ANA MARIA	53-08-29-101-013.000-008	Y	N	N
31	BARGER, CHRISTINA M	53-08-29-101-014.000-008	Y	N	N
32	NO READILY AVAILABLE OWNERSHIP DATA	53-08-29-100-026.000-008	Y	N	N

NUMBER	OWNER NAME	PARCEL ID	EXISTING EASEMENT	PROPOSED PERMANENT	PROPOSED TEMPORARY
33	CLEAR CREEK CEMETERY ASSOCIATION TRUSTEES OF	53-08-29-100-033.000-008	Y	N	Y
34	CLEAR, CREEK CEMETARY	53-08-28-200-027.000-008	Y	N	Y
35	BOWER, KIP LEE	53-08-21-300-084.000-008	Y	N	N
36	CORBIN, TED & SANDRA; WM BLACK	53-08-21-300-039.000-008	Y	N	N
37	CHESTNUT, LARRY D & GLENDA J	53-08-21-300-052.000-008	Y	N	N
38	BRUCE, JO ANNA	53-08-21-300-059.000-008	Y	N	N
39	HELTON, DANIEL K & ELIZABETH S	53-08-20-400-015.000-008	Y	N	N
40	WRIGHT, JOSEPH WILLIAM	53-08-20-400-116.000-008	Y	N	N
41	WARD, JOE DEAN & DENA DANETTE	53-08-20-400-121.000-008	Y	N	N
42	LAFFERTY, DUSTIN	53-08-20-400-111.000-008	Y	N	N
43	BUNCH, HANNAH C & LANDON A	53-08-20-400-107.000-008	Y	N	N
44	MCKENZIE, STEPHANIE L	53-08-20-400-113.000-008	Y	N	N
45	LARRY D & GLENDA J CHESTNUT TRUST	53-08-21-300-032.000-008	Y	N	N
46	CHESTNUT, LARRY D & GLENDA J	53-08-21-300-004.000-008	Y	N	N
47	LYSHER, NATALIE J; LYSHERL-SCHERER, JAYME	53-08-21-300-073.000-008	Y	N	N
48	LYSHER, NATALIE J; SCHERE, JAYME LYSHER	53-08-21-300-017.000-008	Y	N	N



RE-ISSUED FOR REVIEW
NOT FOR CONSTRUCTION
1/X/2024

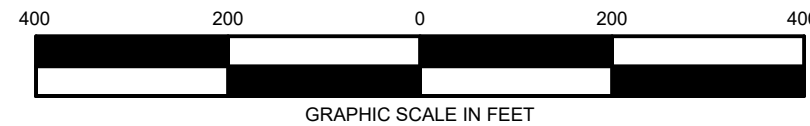

NOTE:
DRAWINGS MAY HAVE BEEN ENLARGED OR REDUCED FROM THE ORIGINAL.
THE GRAPHIC SCALE IS PROVIDED FOR REFERENCE.

REVISIONS		
NO.	DATE	BY DESCRIPTION
A	9/8/2023	TMP ISSUED FOR 90% REVIEW
0	10/17/2023	JCS ISSUED FOR BID
0A	10/31/2023	JCS RE-ISSUED FOR BID
B	1/X/2024	JCS RE-ISSUED FOR REVIEW

OPERATING CENTER: BLOOMINGTON		DIVISION: VEDIN	
PROJECT#: 7604.5142	SCALE: 1" = 200'		
CITY / TOWNSHIP: BLOOMINGTON	COUNTY: MONROE	STATE: IN	

8" NS5153 NEEDMORE TO UNIONVILLE PRESSURE TEST & RETROFIT GENERAL PARCEL MAP		
EnSiteUSA DWG NO. 0006	SHEET NO. SHEET 8	REV. B



DISCLAIMER: ENSITEUSA MAKES NO GUARANTEE THAT THIS SURVEY OR THESE MAPS CONTAINS COMPLETE OR CONCLUSIVE UNDERGROUND OR ABOVEGROUND UTILITY INFORMATION. THE CONTRACTOR IS RESPONSIBLE FOR VERIFYING THE LOCATION & PRESERVATION OF ALL UNDERGROUND AND ABOVEGROUND UTILITIES WHETHER OR NOT DEPICTED ON THESE DRAWINGS. THE CONTRACTOR IS TO CONTACT ALL OWNERS OF UNDERGROUND AND ABOVEGROUND UTILITIES PRIOR TO ANY EXCAVATION.



NUMBER	OWNER NAME	PARCEL ID	EXISTING EASEMENT	PROPOSED PERMANENT	PROPOSED TEMPORARY
49	BOARD OF COMMISSIONERS	53-08-21-300-047.000-008	Y	N	N
50	MAY, NATHAN W & KASIE L	53-08-21-300-050.000-008	Y	N	N
51	GLEYZE, JACQUES & LYDIA BELLE	53-08-21-300-021.000-008	Y	N	N
52	GLEYZE, JACQUES & LYDIA BELLE	53-08-21-300-019.000-008	Y	N	N
53	LARRY D & GLENDA J CHESTNUT REV TRUS	53-08-21-300-054.000-008	Y	N	N
54	HALDEMAN, ANDREW LAURENCE & JESSICA LYNN	53-08-21-300-044.000-008	Y	N	N
55	BRINEGAR, RICHARD T.	53-08-21-300-055.000-008	Y	N	N
56	ACTON, CHRISTOPHER P & REBECCA J	53-08-21-300-041.001-008	Y	N	N
57	EMPSON, LISA M & EMPSON, ANDREW S	53-08-21-300-041.000-008	Y	N	N
58	TODD, ROBERT G. & HARDIE, JANICE A	53-08-21-300-062.000-008	Y	N	N
59	PATEL, JAYANDRA; PATEL	53-08-21-300-064.000-008	Y	N	N
60	PATEL, JAYANDRAKUMAR D & JAGDISH	53-08-21-300-082.000-008	Y	N	N
61	ERLER, STEPHEN P	53-08-21-200-025.000-008	Y	N	N
62	GRUBB, DONALD E. & WANETA J. TRUST	53-08-21-200-023.000-008	Y	N	N
63	SUMMERS, SAM	53-08-21-200-020.000-008	Y	N	N
64	FREEMAN, MARK & YVONNE	53-08-21-200-035.000-008	Y	N	N
65	CHASTEEN, PAUL R. & TANYA S.	53-08-21-200-036.000-008	Y	N	N

NUMBER	OWNER NAME	PARCEL ID	EXISTING EASEMENT	PROPOSED PERMANENT	PROPOSED TEMPORARY
66	WALNUT STREET COURTYARD LLC	53-08-21-200-134.000-008	Y	N	N
67	BANKS, JEREMY	53-08-21-200-015.000-008	Y	N	N
68	LUNG, JENNIFER L	53-08-21-200-016.000-008	Y	N	N
69	DUNIGAN, CALEB W	53-08-21-200-037.000-008	Y	N	N
70	LANE, REGENIA IRENE	53-08-21-200-112.000-008	Y	N	N
71	PERRY, JOSEPH R & HEATHER M	53-08-21-200-137.000-008	Y	N	N
72	WHITE, TERENCE C & RUTH E	53-08-21-200-043.000-008	Y	N	N
73	WILSON, WILLIAM & BRADLEY	53-08-21-200-062.000-008	Y	N	N
74	KROGER LTD PARTNERSHIP	53-08-21-200-075.000-008	Y	N	N
75	CLEAR CREEK CROSSING LLC	53-08-21-200-087.000-008	Y	N	N
76	WM PARKS LLC	53-08-21-200-086.000-008	Y	N	N
77	BOARD OF COMMISSIONERS OF MONROE CO	53-08-21-200-111.000-008	Y	N	N
78	CAG INVESTMENTS, LLC	53-01-52-253-002.000-009	Y	N	N
79	RHOLJE LLC	53-01-53-130-500.000-009	Y	N	N
80	SCOTT, JERRY D & JOYCE D	53-01-53-131-500.000-009	Y	N	N
81	AUTO VEST II LLC	53-01-53-681-002.000-009	Y	N	Y

K:\7604-5142-8n-NS505610-Cover\7604-5142-0007\11/02/2024-9:26:51 PM, Last Saved 11/16/2023 2:05:25 PM by DWEEESLING, Last Plot 11/02/2024 9:26:51 PM by JESSICA LAMB



**RE-ISSUED FOR REVIEW
NOT FOR CONSTRUCTION
1/1/2024**

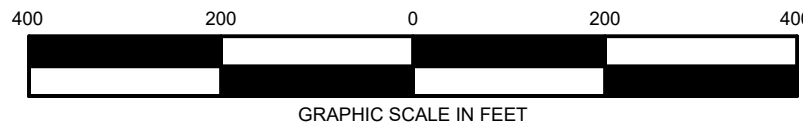

NOTE:
DRAWINGS MAY HAVE BEEN ENLARGED OR REDUCED FROM THE ORIGINAL.
THE GRAPHIC SCALE IS PROVIDED FOR REFERENCE.

REVISIONS			
NO.	DATE	BY	DESCRIPTION
A	9/8/2023	TMP	ISSUED FOR 90% REVIEW
0	10/17/2023	JCS	ISSUED FOR BID
B	1/1/2024	JCS	RE-ISSUED FOR REVIEW
----	----	----	----

OPERATING CENTER: BLOOMINGTON		DIVISION: VEDIN	
PROJECT#: 7604.5142	SCALE: 1" = 200'		
CITY / TOWNSHIP: BLOOMINGTON	COUNTY: MONROE	STATE: IN	

8" NS5153 NEEDMORE TO UNIONVILLE PRESSURE TEST & RETROFIT GENERAL PARCEL MAP		
EnSiteUSA DWG NO. 0007	SHEET NO. SHEET 9	REV. B



DISCLAIMER: ENSITEUSA MAKES NO GUARANTEE THAT THIS SURVEY OR THESE MAPS CONTAINS COMPLETE OR CONCLUSIVE UNDERGROUND OR ABOVEGROUND UTILITY INFORMATION. THE CONTRACTOR IS RESPONSIBLE FOR VERIFYING THE LOCATION & PRESERVATION OF ALL UNDERGROUND AND ABOVEGROUND UTILITIES WHETHER OR NOT DEPICTED ON THESE DRAWINGS. THE CONTRACTOR IS TO CONTACT ALL OWNERS OF UNDERGROUND AND ABOVEGROUND UTILITIES PRIOR TO ANY EXCAVATION.

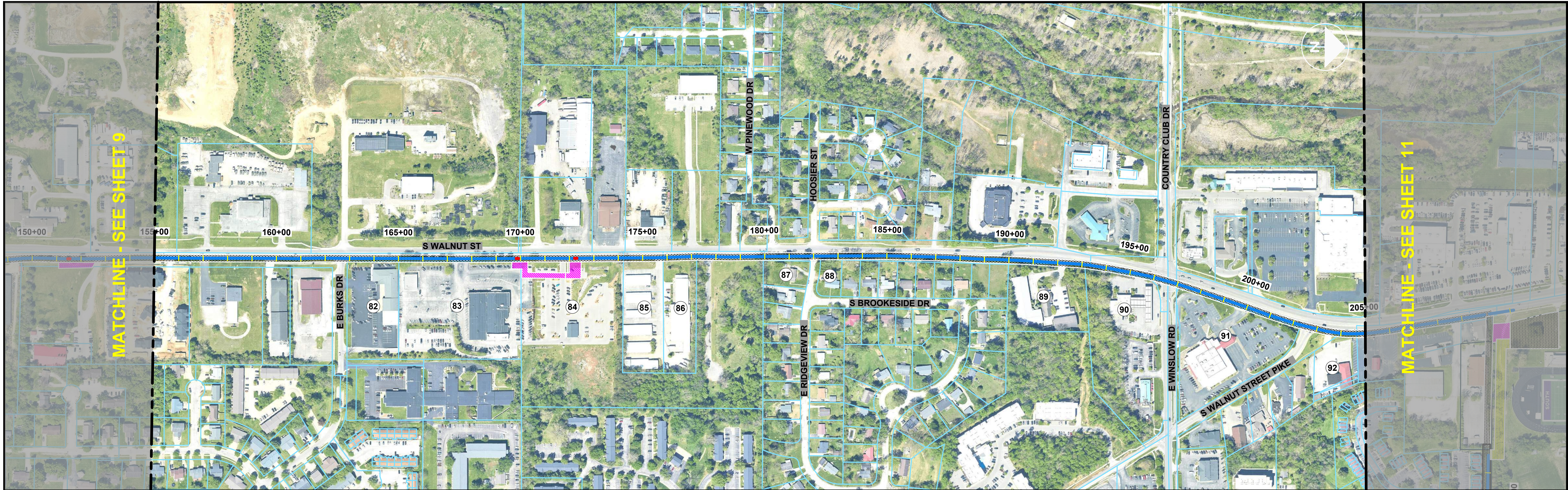

NUMBER	OWNER NAME	PARCEL ID	EXISTING EASEMENT	PROPOSED PERMANENT	PROPOSED TEMPORARY
82	ROYAL REALTY CO	53-08-16-300-045.000-009	Y	N	N
83	ROYAL REALTY CO	53-08-16-300-041.000-009	Y	N	Y
84	CRMR 2 LLC	53-08-16-206-003.000-009	Y	N	Y
85	STORAGE UNLIMITED LLC	53-08-16-205-002.000-009	Y	N	N
86	GORNALL EUBANKS 3001LLC	53-08-16-205-001.000-009	Y	N	N
87	MCCLANAHAN, COLIN A & ALLISON D	53-08-16-204-024.000-009	Y	N	N
88	WILBUR, MARY FRANCES	53-08-16-204-010.000-009	Y	N	N
89	AUTOVEST LLC	53-08-16-200-065.000-009	Y	N	N
90	WINSLOW & WALNUT, LLC	53-08-16-200-055.000-009	Y	N	N
91	INDIANA UNIVERSITY CREDIT UNION	53-08-09-300-007.000-009	Y	N	N
92	BAUGH, PAUL F. & REBECCA F.	53-08-09-300-010.000-009	Y	N	N

K:\7604_5142_Bn_NS5056\0-Cover\7604_5142_0008\11/02/2024 9:27:02 PM, Last Saved 11/16/2023 2:05:26 PM by DKESLINGS, Last Plot 11/02/2024 9:27:02 PM by JESSICA LAMB



**RE-ISSUED FOR REVIEW
NOT FOR CONSTRUCTION
1/X/2024**

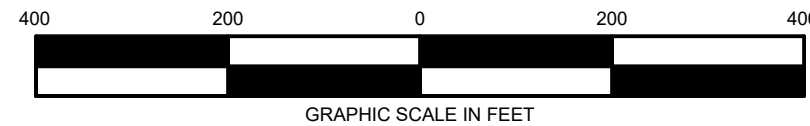

NOTE:
DRAWINGS MAY HAVE BEEN ENLARGED OR REDUCED FROM THE ORIGINAL.
THE GRAPHIC SCALE IS PROVIDED FOR REFERENCE.

REVISIONS			
NO.	DATE	BY	DESCRIPTION
A	9/8/2023	TMP	ISSUED FOR 90% REVIEW
0	10/17/2023	JCS	ISSUED FOR BID
B	1/X/2024	JCS	RE-ISSUED FOR REVIEW
----	----	----	----

OPERATING CENTER: BLOOMINGTON		DIVISION: VEDIN	
PROJECT#: 7604.5142	SCALE: 1" = 200'		
CITY / TOWNSHIP: BLOOMINGTON	COUNTY: MONROE	STATE: IN	

8" NS5153 NEEDMORE TO UNIONVILLE PRESSURE TEST & RETROFIT GENERAL PARCEL MAP			
EnSiteUSA DWG NO. 0008	SHEET NO. SHEET 10	REV. B	



DISCLAIMER: ENSITEUSA MAKES NO GUARANTEE THAT THIS SURVEY OR THESE MAPS CONTAINS COMPLETE OR CONCLUSIVE UNDERGROUND OR ABOVEGROUND UTILITY INFORMATION. THE CONTRACTOR IS RESPONSIBLE FOR VERIFYING THE LOCATION & PRESERVATION OF ALL UNDERGROUND AND ABOVEGROUND UTILITIES WHETHER OR NOT DEPICTED ON THESE DRAWINGS. THE CONTRACTOR IS TO CONTACT ALL OWNERS OF UNDERGROUND AND ABOVEGROUND UTILITIES PRIOR TO ANY EXCAVATION.

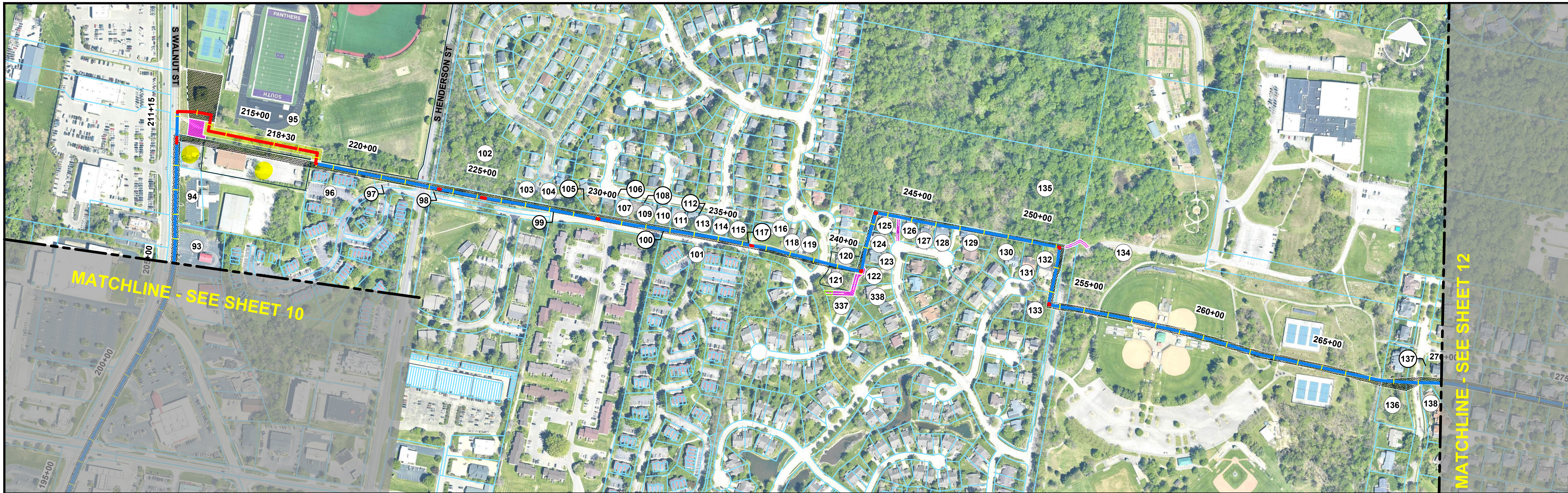

NUMBER	OWNER NAME	PARCEL ID	EXISTING EASEMENT	PROPOSED PERMANENT	PROPOSED TEMPORARY
93	MCCORD, LESLIE MARTIN	53-08-09-300-013.000-009	N	N	N
94	BUETEL, SHONNA R FLYNN CONARD	53-08-09-300-041.000-009	Y	N	N
95	MCCSC 1996 SCHOOL BUILDING CORPORATION	53-08-09-300-044.000-009	Y	Y	Y
96	TIMBER RIDGE HOMEOWNERS ASSOC	53-01-55-626-502.000-009	Y	N	N
97	TIMBER RIDGE HOMEOWNERS ASSOC	53-01-55-626-501.000-009	Y	N	N
98	CITY OF BLOOMINGTON	53-08-09-405-009.000-009	Y	N	N
99	NO READILY AVAILABLE OWNERSHIP DATA	53-08-09-405-010.000-009	Y	N	N
100	NO READILY AVAILABLE OWNERSHIP DATA	53-08-09-421-013.000-009	Y	N	N
101	WINSLOW, RIDGE CORP	53-08-09-424-021.000-009	Y	N	N
102	WINSLOW FARM COMMUNITY ASSOCIATION	53-08-09-405-077.000-009	Y	N	N
103	GONIN, MADELEINE	53-08-09-405-058.000-009	Y	N	N
104	KALPAKIDIS, GIORGIOS D & RICH	53-08-09-405-045.000-009	Y	N	N
105	BAILEY, JACOB	53-08-09-418-012.000-009	Y	N	N
106	BLOOMGARDEN, ANDREW J	53-08-09-418-006.000-009	Y	N	N
107	NEUFELD, JONATHAN D	53-08-09-418-010.000-009	Y	N	N
108	PENNINGTON, CADY H	53-08-09-418-011.000-009	Y	N	N
109	CLARK, REBECCA H	53-08-09-419-002.000-009	Y	N	N
110	YOU, ERKANG & XU, TIAN	53-08-09-419-010.000-009	Y	N	N
111	STEELE, CHARLES N & PATRICIA A	53-08-09-419-004.000-009	Y	N	N
112	LEMKE, JOHN & JULIE	53-08-09-419-005.000-009	Y	N	N
113	BOREN, ANDREW R & YODER, BRITTANY N	53-08-09-419-003.000-009	Y	N	N
114	OLIVER, GENEVIEVE T	53-08-09-420-005.000-009	Y	N	N
115	WOODSIDE, DANIEL JAY	53-08-09-420-006.000-009	Y	N	N
116	REITMEYER, CHAD & NICOLE	53-08-09-426-009.000-009	Y	N	N

NUMBER	OWNER NAME	PARCEL ID	EXISTING EASEMENT	PROPOSED PERMANENT	PROPOSED TEMPORARY
117	NO READILY AVAILABLE OWNERSHIP DATA	53-08-09-421-015.000-009	Y	N	N
118	FRIEDMAN, SETH A	53-08-09-426-016.000-009	Y	N	N
119	PARROTT, KATHY	53-08-09-426-004.000-009	Y	N	N
120	LEWIS, JOAN E	53-08-09-426-012.000-009	Y	N	N
121	JBM ACCEPTANCE, LLC	53-08-09-426-020.000-009	Y	N	N
122	STICKFORTH, THOMAS A	53-08-09-425-005.000-009	Y	N	Y
123	KOPP, AMY E	53-08-09-425-004.000-009	Y	N	N
124	PASSET, JOANNE E & WEHMAN, DEBORAH S	53-08-09-425-002.000-009	Y	N	N
125	Richard Straube	53-08-09-425-008.000-009	Y	N	Y
126	BROWN, SCOTT W.	53-08-09-425-007.000-009	Y	N	N
127	O'CONNOR, LOUISE C	53-08-09-425-014.000-009	Y	N	N
128	KOEHNLEIN, PHYLLIS EVELYN	53-08-09-425-017.000-009	Y	N	N
129	BENJAMIN, JOHN S & JANE M	53-08-09-425-015.000-009	Y	N	N
130	THOMAS, JEFFREY B & CONNIE M KUHLMAN REVOCABLE LIV	53-08-09-424-006.000-009	Y	N	N
131	RODRIGUEZ, JASON DANIEL & MEREDITH JANTZEN	53-08-09-424-005.000-009	Y	N	N
132	HORN, JOEL T	53-08-09-424-010.000-009	Y	N	N
133	BLACKBURN, CHRISTOPHER & MARLISE	53-08-09-424-014.000-009	Y	N	N
134	CITY OF BLOOMINGTON	53-08-10-300-045.000-009	Y	N	Y
135	CITY OF BLOOMINGTON	53-08-09-400-006.000-009	N	N	Y
136	HOPKINS, PATRICK E & HODDER, LESLIE D	53-08-10-300-067.000-009	Y	N	N
137	BENDER, DAVID C & SANDY X	53-08-10-300-076.000-009	Y	N	N
138	COOK, CARL & MARCY	53-08-10-300-064.000-009	Y	N	N
337	McMichael, Mary A	53-08-09-426-023.000-009	N	N	Y
338	Watson, Richard & Karen A	53-08-09-425-011.000-009	N	N	Y

K:\7604-5142-8m-NS505660-Cover\7604-5142-009\1102024-02-27-14-PM-Last Saved 11/16/2023 2:05:28 PM by DKESLINGS; Last Pk 11/02/2024 3:27:14 PM by JESSICA LAMB



**RE-ISSUED FOR REVIEW
NOT FOR CONSTRUCTION
1/1X/2024**



NOTE:
DRAWINGS MAY HAVE BEEN ENLARGED OR REDUCED FROM THE ORIGINAL.
THE GRAPHIC SCALE IS PROVIDED FOR REFERENCE.

REVISIONS			
NO.	DATE	BY	DESCRIPTION
A	9/8/2023	TMP	ISSUED FOR 90% REVIEW
0	10/17/2023	JCS	ISSUED FOR BID
0A	10/31/2023	JCS	RE-ISSUED FOR BID
B	1/1X/2024	JCS	RE-ISSUED FOR REVIEW

OPERATING CENTER: BLOOMINGTON	DIVISION: VEDIN
PROJECT#: 7604.5142	SCALE: 1" = 200'
CITY / TOWNSHIP: BLOOMINGTON	COUNTY: MONROE
STATE: IN	

8" NS5153 NEEDMORE TO UNIONVILLE PRESSURE TEST & RETROFIT GENERAL PARCEL MAP		
ENSiteUSA DWG NO. 0009	SHEET NO. SHEET 11	REV. B



DISCLAIMER: ENSITEUSA MAKES NO GUARANTEE THAT THIS SURVEY OR THESE MAPS CONTAINS COMPLETE OR CONCLUSIVE UNDERGROUND OR ABOVEGROUND UTILITY INFORMATION. THE CONTRACTOR IS RESPONSIBLE FOR VERIFYING THE LOCATION & PRESERVATION OF ALL UNDERGROUND AND ABOVEGROUND UTILITIES WHETHER OR NOT DEPICTED ON THESE DRAWINGS. THE CONTRACTOR IS TO CONTACT ALL OWNERS OF UNDERGROUND AND ABOVEGROUND UTILITIES PRIOR TO ANY EXCAVATION.

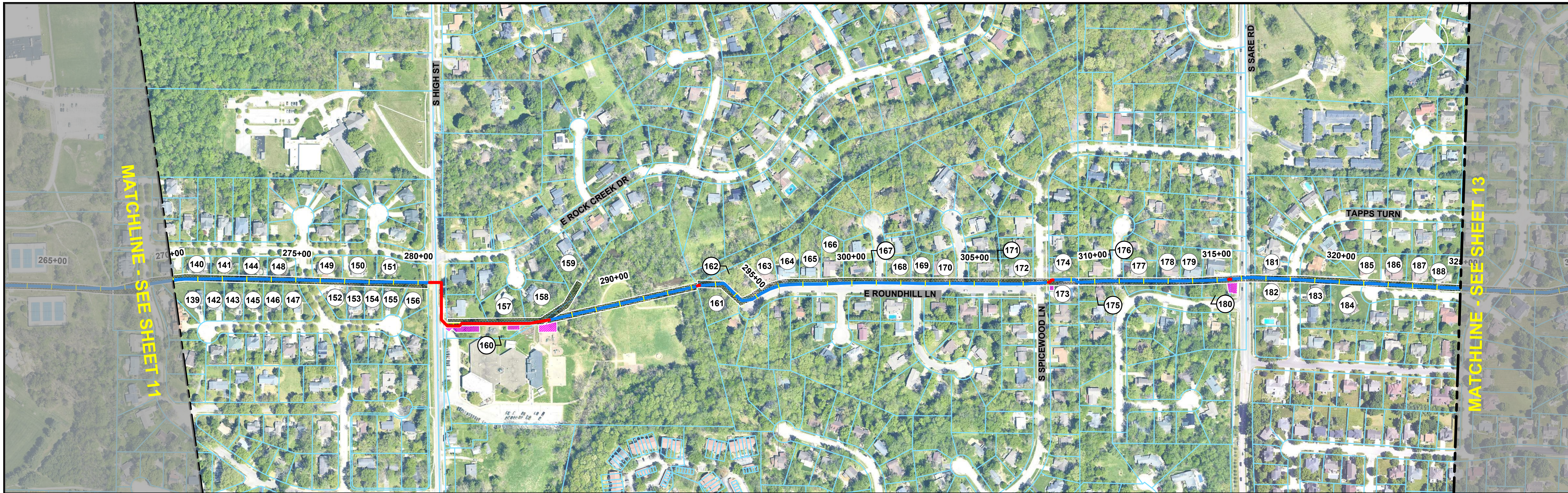

NUMBER	OWNER NAME	PARCEL ID	EXISTING EASEMENT	PROPOSED PERMANENT	PROPOSED TEMPORARY
139	WHEELER, KIRA M & RYAN	53-08-10-300-065.000-009	Y	N	N
140	WILLIAMS, STANLEY E	53-08-10-300-033.000-009	Y	N	N
141	POOL, LARRY DEWAYNE JR & PRASHANTI TEHANEER RATWATT	53-08-10-300-040.000-009	Y	N	N
142	GEORGE, STERLING R JR & JENNIFER L	53-08-10-300-069.000-009	Y	N	N
143	ECHOLS, WILLIAM G & MEREDITH E	53-08-10-300-038.000-009	Y	N	N
144	KERSCHBAUM, JOSEPH & VALERIE	53-08-10-300-039.000-009	Y	N	N
145	FULTON, BRAD & CARLA	53-08-10-300-032.000-009	Y	N	N
146	MURPHY, MARK W & JENNIFER M	53-08-10-300-034.000-009	Y	N	N
147	MERKLEY, KENNETH J & ANDREA C	53-08-10-300-070.000-009	Y	N	N
148	SUNG, ROBERT & WHANG, TALLEY B	53-08-10-300-081.000-009	Y	N	N
149	ROCHA, LUIS M & DEBORAH S	53-08-10-300-083.000-009	Y	N	N
150	SCHROEDER, JOSEPH H & AMANDA J	53-08-10-300-021.000-009	Y	N	N
151	WALTER, HARRY R	53-08-10-300-079.000-009	Y	N	N
152	GABALE, AMIT PRAMOD & UMA AMIT	53-08-10-300-073.000-009	Y	N	N
153	KOU, BINBIN; FANG, FANG	53-08-10-300-026.000-009	Y	N	N
154	MCMULLIN, JEFF L & MELANIE S	53-08-10-300-072.000-009	Y	N	N
155	ERKELENS, JEFFREY D & LINDSEY	53-08-10-300-063.000-009	Y	N	N
156	FITZGIBBONS, DIANA C	53-08-10-300-062.000-009	Y	N	N
157	FIERMAN, WILLIAM & HARRIETT	53-08-10-406-003.000-009	Y	N	N
158	MCGREGOR, EUGENE B. & CAROL C.	53-08-10-406-010.000-009	Y	N	N
159	CARLIN, JEFFREY B & CHRISTINE A	53-08-10-406-018.000-009	Y	N	N
160	MONROE COUNTY COMMUNITY SCHOOL CORP	53-08-10-400-003.000-009	Y	N	Y
161	SYER, HENRY WORONICZ & FONTAINE	53-08-10-402-017.000-009	Y	N	N
162	MEYER, CHRISTOPHER J; LOVE, CRYSTAL E	53-08-10-402-006.000-009	Y	N	N
163	STASNY & HORN IGP	53-08-10-402-016.000-009	Y	N	N

NUMBER	OWNER NAME	PARCEL ID	EXISTING EASEMENT	PROPOSED PERMANENT	PROPOSED TEMPORARY
164	FORTHOFER, SCOTT & KATHERINE C	53-08-10-402-010.000-009	Y	N	N
165	MELNICK, DANIEL & RACHEL	53-08-10-402-011.000-009	Y	N	N
166	PHELPS, R. J. & SHANNON J.	53-08-10-402-014.000-009	Y	N	N
167	MCFADDEN, LANE NEWTON & ANNE NEWTON	53-08-10-402-004.000-009	Y	N	N
168	JOHNSON, SYLVESTER A & HEATHER A NICHOLSON	53-08-10-402-019.000-009	Y	N	N
169	BRINEGAR, RONALD J & LORI J	53-08-10-403-006.000-009	Y	N	N
170	GUL, ALEXANDER	53-08-10-403-002.000-009	Y	N	N
171	KRAVITZ, BENJAMIN STEPHEN; BECHT, ROBIN LEE	53-08-10-403-026.000-009	Y	N	N
172	CAROLINE A DOWD-HIGGINS & C DAVID TR	53-08-10-403-021.000-009	Y	N	N
173	SCHWARTZMAN, EDWARD E & JAIMIE	53-08-10-412-005.000-009	Y	N	Y
174	MAY, SCOTT G JR	53-08-10-403-017.000-009	Y	N	N
175	PIZZO, FIORA G REVOCABLE LIVING TRUST	53-08-11-306-016.000-009	Y	N	N
176	PIPER, CLARK J & AMY	53-08-11-306-012.000-009	Y	N	N
177	MORRIS, MICHAEL J & JILL C	53-08-11-306-017.000-009	Y	N	N
178	VLASMAN, ALAN C & CINDY J	53-08-11-306-002.000-009	Y	N	N
179	SINN, CHARLES R III & TINA A IRVINE	53-08-11-306-003.000-009	Y	N	N
180	Sun Cho & Hi Jung Chong	53-08-11-306-001.000-009	Y	N	Y
181	BAVETTA, JAMES A IRREVOCABLE TRUST	53-08-11-308-045.000-009	Y	N	N
182	GOODMAN, JOSHUA L	53-08-11-308-043.000-009	Y	N	N
183	STRYKER, ROBERT E & KAREN M	53-08-11-308-012.000-009	Y	N	N
184	ABEL, DONALD C & DIANE S LEGOMSKY	53-08-11-308-057.000-009	Y	N	N
185	SILBERBERG, PHILLIP & SUSAN L	53-08-11-308-033.000-009	Y	N	N
186	WEBBER, RAYMOND DOUGLAS	53-08-11-308-031.000-009	Y	N	N
187	ROLF, NICOLE & BOYD, JAMES	53-08-11-308-014.000-009	Y	N	N
188	HARMAN, ROBERT E & ANN R	53-08-11-308-010.000-009	Y	N	N

K:\7604-5142-00-01\11020204-02-27-25.PNL Last Saved 11/16/2023 2:05:30 PM by DWEEESLING. Last Pk 11/02/2024 3:27:25 PM by JESSICA LAMB



**RE-ISSUED FOR REVIEW
NOT FOR CONSTRUCTION
1/1X/2024**



NOTE:
DRAWINGS MAY HAVE BEEN ENLARGED OR REDUCED FROM THE ORIGINAL.
THE GRAPHIC SCALE IS PROVIDED FOR REFERENCE.

REVISIONS			
NO.	DATE	BY	DESCRIPTION
A	9/8/2023	TMP	ISSUED FOR 90% REVIEW
0	10/17/2023	JCS	ISSUED FOR BID
B	1/1X/2024	JCS	RE-ISSUED FOR REVIEW

OPERATING CENTER: BLOOMINGTON		DIVISION: VEDIN	
PROJECT#: 7604.5142	SCALE: 1" = 200'		
CITY / TOWNSHIP: BLOOMINGTON	COUNTY: MONROE	STATE: IN	

8" NS5153 NEEDMORE TO UNIONVILLE PRESSURE TEST & RETROFIT GENERAL PARCEL MAP			
EnSiteUSA DWG NO. 0010	SHEET NO. SHEET 12	REV. B	



DISCLAIMER: ENSITEUSA MAKES NO GUARANTEE THAT THIS SURVEY OR THESE MAPS CONTAINS COMPLETE OR CONCLUSIVE UNDERGROUND OR ABOVEGROUND UTILITY INFORMATION. THE CONTRACTOR IS RESPONSIBLE FOR VERIFYING THE LOCATION & PRESERVATION OF ALL UNDERGROUND AND ABOVEGROUND UTILITIES WHETHER OR NOT DEPICTED ON THESE DRAWINGS. THE CONTRACTOR IS TO CONTACT ALL OWNERS OF UNDERGROUND AND ABOVEGROUND UTILITIES PRIOR TO ANY EXCAVATION.

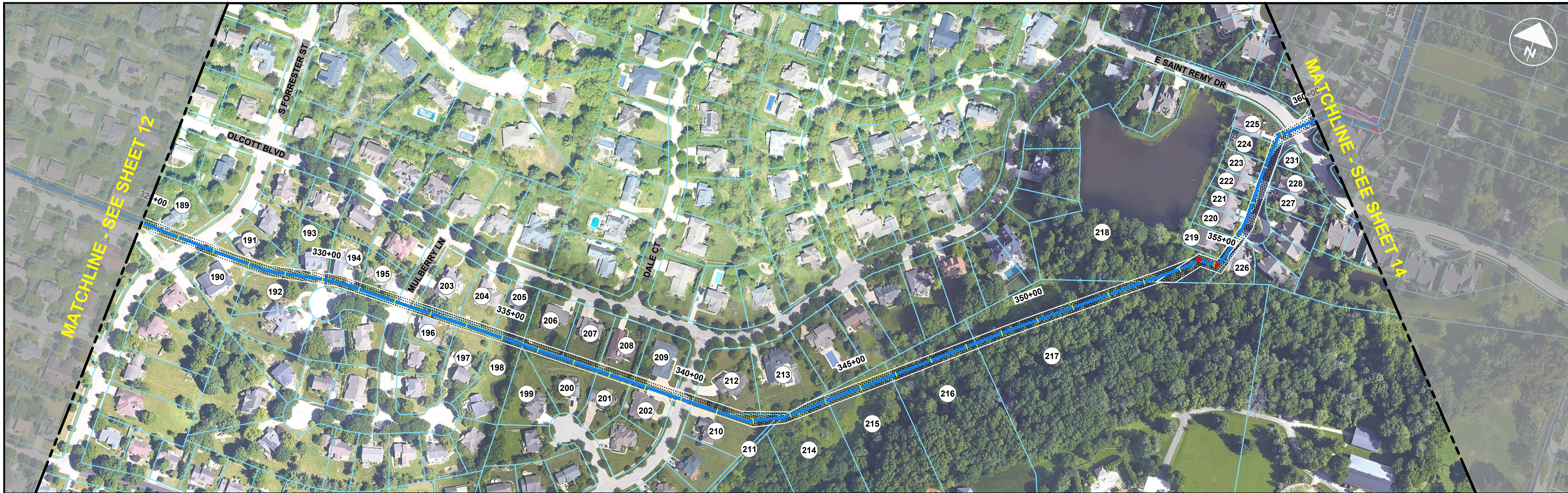

NUMBER	OWNER NAME	PARCEL ID	EXISTING EASEMENT	PROPOSED PERMANENT	PROPOSED TEMPORARY
189	DUNN, ELIZABETH	53-08-11-308-055.000-009	Y	N	N
190	DUNN, WANDELOHR & MARY ANN IRREVOCABLE TRUST & W/L	53-08-11-308-047.000-009	Y	N	N
191	RAGHAVACHARI TRUST	53-08-11-313-017.000-009	Y	N	N
192	MEHALECHKO, SUE HANNA REVOCABLE TRUST	53-08-11-313-011.000-009	Y	N	N
193	WHITE, MARK P & DEANNA E	53-08-11-313-001.000-009	Y	N	N
194	LIN, KANG; ZHOU, JINYING	53-08-11-313-012.000-009	Y	N	N
195	BIGGERSTAFF, LARRY T & WALTERS, CHARLA D	53-08-11-313-036.000-009	Y	N	N
196	SARGUNAM, ISSAC L PRINCE & MARY V P	53-08-11-313-013.000-009	Y	N	N
197	HUNT, MARION G	53-08-11-313-020.000-009	Y	N	N
198	MCKAMEY, JERRY L & DIANA L	53-08-11-313-021.000-009	Y	N	N
199	ACHARYA, RAJ & MYTRI	53-08-11-405-020.000-009	Y	N	N
200	COLE, BRUCE M & DOREEN L	53-08-11-405-010.000-009	Y	N	N
201	LACEFIELD, SONI M & SHIMODA	53-08-11-405-012.000-009	Y	N	N
202	K & L RESIDENTIAL LLC	53-08-11-405-008.000-009	Y	N	N
203	KENNEDY, DANIEL P & TANYA R L	53-08-11-313-033.000-009	Y	N	N
204	MITER, PETER & LONA	53-08-11-313-025.000-009	Y	N	N
205	FRALEY, JOHN A & HOLLY M	53-08-11-313-002.000-009	Y	N	N
206	DUPREE, RICHARD K & DIANA L	53-08-11-404-001.000-009	Y	N	N
207	WOODMAN, BRIAN J; PETERSON, ZOE D	53-08-11-404-060.000-009	Y	N	N
208	MITCHELL, CHRISTINE	53-01-53-069-521.000-009	Y	N	N
209	WRAY, RALPH D & MARTHA C	53-08-11-404-051.000-009	Y	N	N

NUMBER	OWNER NAME	PARCEL ID	EXISTING EASEMENT	PROPOSED PERMANENT	PROPOSED TEMPORARY
210	GEOGHEGAN, WILLIAM J & JENELLE L	53-08-11-405-013.000-009	Y	N	N
211	BLACKWELL CONSTRUCTION INC	53-08-11-405-019.000-009	Y	N	N
212	HUSTAD, THOMAS P	53-08-11-404-050.000-009	Y	N	N
213	HINNEFELD, JERRY W & JUDITH D	53-08-11-404-012.000-009	Y	N	N
214	CURRY, TYLER E & COLLEEN G	53-08-11-400-002.000-008	Y	N	N
215	NUNN, KENNETH L & NUNN, LEAH K	53-08-11-400-012.000-008	Y	N	N
216	MAGUIRE, RICHARD N & KAREN JOY	53-08-11-400-017.000-008	Y	N	N
217	GROSSMAN, R DANIEL M D	53-08-11-400-014.000-008	Y	N	N
218	SAINT REMY HOMEOWNERS ASSOC INC	53-08-11-401-029.000-009	Y	N	N
219	LEWISON, MITZI A FAMILY TRUST	53-08-11-401-009.000-009	Y	N	N
220	FOX, RAMONA RAY REVOCABLE TRUST	53-08-11-401-024.000-009	Y	N	N
221	BALDNER, BETTINA	53-08-11-401-006.000-009	Y	N	N
222	WELCH, DAVID L & PEGGY M	53-08-11-401-011.000-009	Y	N	N
223	CRAWFORD, JANE	53-08-11-401-025.000-009	Y	N	N
224	WELCH, DAVID L & PEGGY M TRUST	53-08-11-401-008.000-009	Y	N	N
225	CHILDES, G THOMAS & SUE E	53-08-11-401-026.000-009	Y	N	N
226	WATTS, ANDRE & BRAND, JOAN	53-08-11-401-004.000-009	Y	N	N
227	STUEBE, SUZANNE	53-08-11-401-002.000-009	Y	N	N
228	MARKS FAMILY LOCKBOX TRUST	53-08-11-401-012.000-009	Y	N	N
229	SAINT REMY HOMEOWNERS ASSOC INC	53-08-11-401-030.000-009	Y	N	N

K:\7604-5142-8r-NS5060-Cover\7604-5142-0011\11022024-9:27:37 PM.dwg Saved 11/16/2023 2:05:52 PM by DWEEESLING. Last Pk 11/02/2024 9:27:37 PM by JESSICA LAMB



**RE-ISSUED FOR REVIEW
NOT FOR CONSTRUCTION
1/1X/2024**



NOTE:
DRAWINGS MAY HAVE BEEN ENLARGED OR REDUCED FROM THE ORIGINAL.
THE GRAPHIC SCALE IS PROVIDED FOR REFERENCE.

REVISIONS			
NO.	DATE	BY	DESCRIPTION
A	9/8/2023	TMP	ISSUED FOR 90% REVIEW
0	10/17/2023	JCS	ISSUED FOR BID
B	1/1X/2024	JCS	RE-ISSUED FOR REVIEW

OPERATING CENTER: BLOOMINGTON	DIVISION: VEDIN
PROJECT#: 7604.5142	SCALE: 1" = 200'
CITY / TOWNSHIP: BLOOMINGTON	COUNTY: MONROE
STATE: IN	

8" NS5153 NEEDMORE TO UNIONVILLE PRESSURE TEST & RETROFIT GENERAL PARCEL MAP		
EnSiteUSA DWG NO. 0011	SHEET NO. SHEET 13	REV. B



DISCLAIMER: ENSITEUSA MAKES NO GUARANTEE THAT THIS SURVEY OR THESE MAPS CONTAINS COMPLETE OR CONCLUSIVE UNDERGROUND OR ABOVEGROUND UTILITY INFORMATION. THE CONTRACTOR IS RESPONSIBLE FOR VERIFYING THE LOCATION & PRESERVATION OF ALL UNDERGROUND AND ABOVEGROUND UTILITIES WHETHER OR NOT DEPICTED ON THESE DRAWINGS. THE CONTRACTOR IS TO CONTACT ALL OWNERS OF UNDERGROUND AND ABOVEGROUND UTILITIES PRIOR TO ANY EXCAVATION.



NUMBER	OWNER NAME	PARCEL ID	EXISTING EASEMENT	PROPOSED PERMANENT	PROPOSED TEMPORARY
230	KOBEN, RISE	53-08-11-401-014.000-009	Y	N	N
231	RUCKRIEGLE, JAMES R & KAREN R REV TRUST	53-08-11-401-023.000-009	Y	N	N
232	OGLESBY, WESLEY G & PATRICIA A	53-08-11-118-002.000-009	Y	N	Y
233	MABRY, RICHARD M & SUSAN G	53-08-11-118-001.000-009	Y	N	N
234	MERRY, LEE ANN	53-08-11-117-002.000-009	Y	N	N
235	TAYLOR, LINDA J REVOCABLE TRUST	53-08-11-117-001.000-009	Y	N	N
236	ENGBER, CHERYL A	53-08-11-111-001.000-009	Y	N	N
237	CRANDALL, SARAH C TRUST	53-08-11-111-002.000-009	Y	N	N
238	MEYER, TERESA A	53-08-11-110-002.000-009	Y	N	N
239	DRUCK, DIANE M	53-08-11-110-001.000-009	Y	N	N
240	PIEKARCZYK, ELIZABETH P & DANIEL	53-08-11-109-002.000-009	Y	N	N
241	ACITO, FRANKLIN & SANDRA JOINT REVOCABLE LIVING TR	53-08-11-109-011.000-009	Y	N	N
242	LEWIS, SEAN K	53-08-11-109-010.000-009	Y	N	N
243	QASIM, MUHAMMAD	53-08-11-109-003.000-009	Y	N	N
244	TANNEBERGER, JAMES M	53-08-11-107-002.000-009	Y	N	N
245	SWINGLEY, NATASHA L	53-08-11-107-013.000-009	Y	N	N
246	RATLIFF, MARY BURCH	53-08-11-102-011.000-009	Y	N	N
247	MCCLELLAN, B EDWARD & MARY C	53-08-11-102-018.000-009	Y	N	N
248	JENSEN, ESPEN & ANNA K	53-08-11-102-024.000-009	Y	N	N
249	WILD, DAVID J & SUSAN R	53-08-11-102-038.000-009	Y	N	N

NUMBER	OWNER NAME	PARCEL ID	EXISTING EASEMENT	PROPOSED PERMANENT	PROPOSED TEMPORARY
250	W/L/E, ATAR ARAD & MIMI ZWEIG	53-08-11-102-023.000-009	Y	N	N
251	CLAPACS, J. TERRY & PHYLLIS	53-08-11-102-067.000-009	Y	N	N
252	LOVEJOY, JOSEPH F & MARSHA E	53-08-11-102-025.000-009	Y	N	N
253	ARNOLD, DEAN J & SANDRA L	53-08-11-102-005.000-009	Y	N	N
254	COON, CHARLES F & DIANE S	53-08-11-102-044.000-009	Y	N	N
255	URIDEL, FAITH ARLENE REVOCABLE TRUST	53-01-52-862-201.000-009	Y	N	N
256	BRENNAN, ELIZABETH J	53-01-52-862-202.000-009	Y	N	N
257	YONKMAN, PETER & JANELL	53-01-52-862-203.000-009	Y	N	N
258	LEDON, WILLY REVOCABLE TRUST	53-01-52-862-204.000-009	Y	N	N
259	WALLS, CARL PHILIP	53-01-52-862-205.000-009	Y	N	N
260	KEFFABER, GARY L & BRENDA S	53-01-52-862-206.000-009	Y	N	N
261	MEGLICKI, ZDZISLAW	53-01-52-862-207.000-009	Y	N	N
262	COLEMAN, JOHN M	53-01-52-862-208.000-009	Y	N	N
263	SWANSON, JOHN & COLLEEN REVOCABLE LIVING TRUST	53-01-52-862-209.000-009	Y	N	N
264	BLICKENDORF, JAMES D & KARA A	53-01-52-862-210.000-009	Y	N	N
265	ANEY, ROB A	53-01-52-862-216.000-009	Y	N	N
266	FAALZADA, AHMED Z & SHUKRIA Z	53-01-52-862-217.000-009	Y	N	N
267	ZHONG, JINGHUA & HEI JESSIE WONG	53-08-02-408-063.000-009	Y	N	Y
268	LUBECK, DONNA L LIVING TRUST	53-08-02-408-051.000-009	Y	N	Y

K:\7604_5142_8in_NS5056\0-Cover\7604_5142_0012\10_2024_3:27:49 PM - Last Saved: 11/16/2023 2:05:34 PM by DKEESLING; Last Plot: 1/10/2024 3:27:49 PM by JESSICA LAMIE

RE-ISSUED FOR REVIEW
 NOT FOR CONSTRUCTION
 1/1/2024

NOTE: DRAWINGS MAY HAVE BEEN ENLARGED OR REDUCED FROM THE ORIGINAL. THE GRAPHIC SCALE IS PROVIDED FOR REFERENCE.

REVISIONS			
NO.	DATE	BY	DESCRIPTION
0	10/17/2023	TMP	ISSUED FOR BID
A	1/1/2024	JCS	RE-ISSUED FOR REVIEW

OPERATING CENTER: BLOOMINGTON		DIVISION: VEDIN	
PROJECT#: 7604.5142	SCALE: 1" = 200'		
CITY / TOWNSHIP: BLOOMINGTON	COUNTY: MONROE	STATE: IN	

8" NS5153 NEEDMORE TO UNIONVILLE
PRESSURE TEST & RETROFIT
GENERAL
PARCEL MAP

EnSiteUSA DWG NO. 0012	SHEET NO. SHEET 14	REV. A
------------------------	--------------------	--------

DISCLAIMER: ENSITEUSA MAKES NO GUARANTEE THAT THIS SURVEY OR THESE MAPS CONTAINS COMPLETE OR CONCLUSIVE UNDERGROUND OR ABOVEGROUND UTILITY INFORMATION. THE CONTRACTOR IS RESPONSIBLE FOR VERIFYING THE LOCATION & PRESERVATION OF ALL UNDERGROUND AND ABOVEGROUND UTILITIES WHETHER OR NOT DEPICTED ON THESE DRAWINGS. THE CONTRACTOR IS TO CONTACT ALL OWNERS OF UNDERGROUND AND ABOVEGROUND UTILITIES PRIOR TO ANY EXCAVATION.

K:\7604.5142_8in_NS5056\0-Cover\7604.5142.00\31/10/2024_3:28:00 PM; Last Saved: 11/16/2023 2:05:36 PM by DKEESLINGS; Last Plot: 1/10/2024 3:28:00 PM by JESSICA LAWE

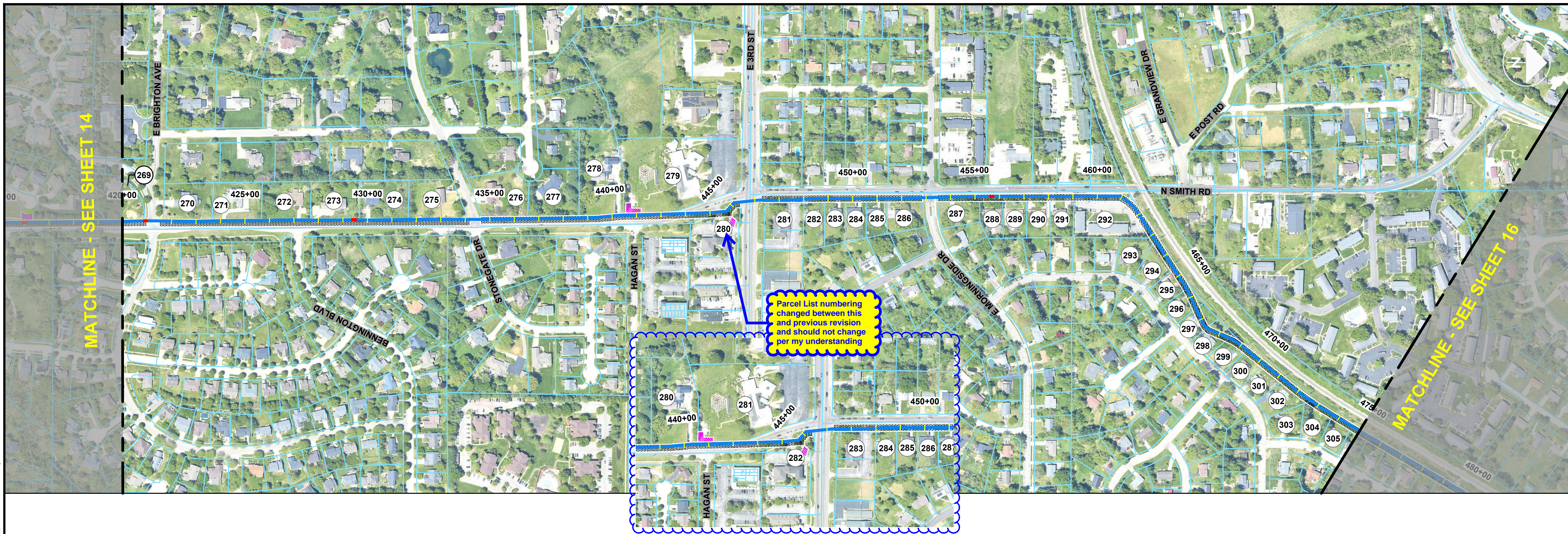

NUMBER	OWNER NAME	PARCEL ID	EXISTING EASEMENT	PROPOSED PERMANENT	PROPOSED TEMPORARY
269	BROWN, BARRY SPENCER & KATHRYN GRACE	53-08-02-408-084.021-009	Y	N	Y
270	LOSTUTTER, MICHAEL L & MARY Z	53-08-02-105-020.000-009	Y	N	N
271	MCLELLAND, STEVEN A & JEANNE M	53-08-02-105-002.000-009	Y	N	N
272	URBAN, RONALD C & BETTY J	53-08-02-105-008.000-009	Y	N	N
273	MITTELSTAEDT, MICHAEL G & CHERYL M	53-08-02-105-013.000-009	Y	N	N
274	WALTON, ANDREA	53-08-02-105-006.000-009	Y	N	N
275	JOHNSON, ASHLEY A	53-08-02-105-019.000-009	Y	N	N
276	MITTELSTAEDT, MICHAEL G & CHERYL M	53-08-02-101-008.000-009	Y	N	N
277	WALTON, ANDREA	53-08-02-101-011.000-009	Y	N	N
278	DECKARD, NORMAN W. & MARY LEE	53-08-02-100-010.000-009	Y	N	N
279	SAINT THOMAS EVANGELICAL LUTHERAN CHURCH INC	53-08-02-100-003.000-009	Y	N	Y
280	MITTELSTAEDT, MICHAEL G & CHERYL M	53-08-02-100-009.000-009	Y	N	Y
281	WALTON, ANDREA	53-05-36-304-013.000-005	Y	N	N
282	LUHOVSKYY, VALENTYN & LUGOVSKA, LUIDMYLA	53-05-36-304-089.000-005	Y	N	N
283	MARCHANT, GREGORY L	53-05-36-304-015.000-005	Y	N	N
284	MITTELSTAEDT, MICHAEL G & CHERYL M	53-05-36-304-018.000-005	Y	N	N
285	WALTON, ANDREA	53-05-36-304-008.000-005	Y	N	N
286	RUSU, DUMITRU DAN & RUSU, VICTOR	53-05-36-304-009.000-005	Y	N	N
287	ORENSTEIN, AVIVA	53-05-36-304-082.000-005	Y	N	N

NUMBER	OWNER NAME	PARCEL ID	EXISTING EASEMENT	PROPOSED PERMANENT	PROPOSED TEMPORARY
288	MITTELSTAEDT, MICHAEL G & CHERYL M	53-05-36-303-002.000-005	Y	N	N
289	WALTON, ANDREA	53-05-36-303-006.000-005	Y	N	N
290	PH PROPERTIES SMITH LLC	53-05-36-303-008.000-005	Y	N	N
291	CRIDER, ROBERT E.	53-05-36-303-005.000-005	Y	N	N
292	EASTSIDE APARTMENTS OF	53-05-36-300-001.000-005	Y	N	N
293	BAILEY, BRENN A W	53-05-36-302-008.000-005	Y	N	N
294	YOUNG, KIMBERLY M & STEVEN H REYNOLDS	53-05-36-302-046.000-005	Y	N	N
295	SMITH, DAVID A & SUSAN E KELLY	53-05-36-302-049.000-005	Y	N	N
296	PARKER, STEPHEN R & RAETTA L	53-05-36-302-054.000-005	Y	N	N
297	SPEICHERT, SUSAN E	53-05-36-302-061.000-005	Y	N	N
298	PETERSON, DORIS A	53-05-36-302-076.000-005	Y	N	N
299	MCBRIDE, DARIAN M	53-05-36-302-082.000-005	Y	N	N
300	MARTIN, NANCY RUTH	53-05-36-302-137.000-005	Y	N	N
301	HUFFMAN, JOHN C. & CAROLYN J.	53-05-36-302-092.000-005	Y	N	N
302	EFFNER, MEGAN A; SHAVER, MATTHEW	53-05-36-302-103.000-005	Y	N	N
303	HICKS, GLENN W	53-05-36-302-111.000-005	Y	N	N
304	DAVENPORT, JONATHAN G & CHRISTINE A	53-05-36-302-142.000-005	Y	N	N
305	MARTIN, REBECCA L & BENJAMIN D	53-05-36-302-009.000-005	Y	N	N



RE-ISSUED FOR REVIEW
NOT FOR CONSTRUCTION
1/1/2024



NOTE: DRAWINGS MAY HAVE BEEN ENLARGED OR REDUCED FROM THE ORIGINAL. THE GRAPHIC SCALE IS PROVIDED FOR REFERENCE.

REVISIONS			
NO.	DATE	BY	DESCRIPTION
0	10/17/2023	TMP	ISSUED FOR BID
A	1/1/2024	JCS	RE-ISSUED FOR REVIEW

OPERATING CENTER: BLOOMINGTON	DIVISION: VEDIN
PROJECT#: 7604.5142	SCALE: 1" = 200'
CITY / TOWNSHIP: BLOOMINGTON	COUNTY: MONROE
STATE: IN	

8" NS5153 NEEDMORE TO UNIONVILLE PRESSURE TEST & RETROFIT GENERAL PARCEL MAP		
EnSiteUSA DWG NO. 0013	SHEET NO. SHEET 15	REV. A



DISCLAIMER: ENSITEUSA MAKES NO GUARANTEE THAT THIS SURVEY OR THESE MAPS CONTAINS COMPLETE OR CONCLUSIVE UNDERGROUND OR ABOVEGROUND UTILITY INFORMATION. THE CONTRACTOR IS RESPONSIBLE FOR VERIFYING THE LOCATION & PRESERVATION OF ALL UNDERGROUND AND ABOVEGROUND UTILITIES WHETHER OR NOT DEPICTED ON THESE DRAWINGS. THE CONTRACTOR IS TO CONTACT ALL OWNERS OF UNDERGROUND AND ABOVEGROUND UTILITIES PRIOR TO ANY EXCAVATION.

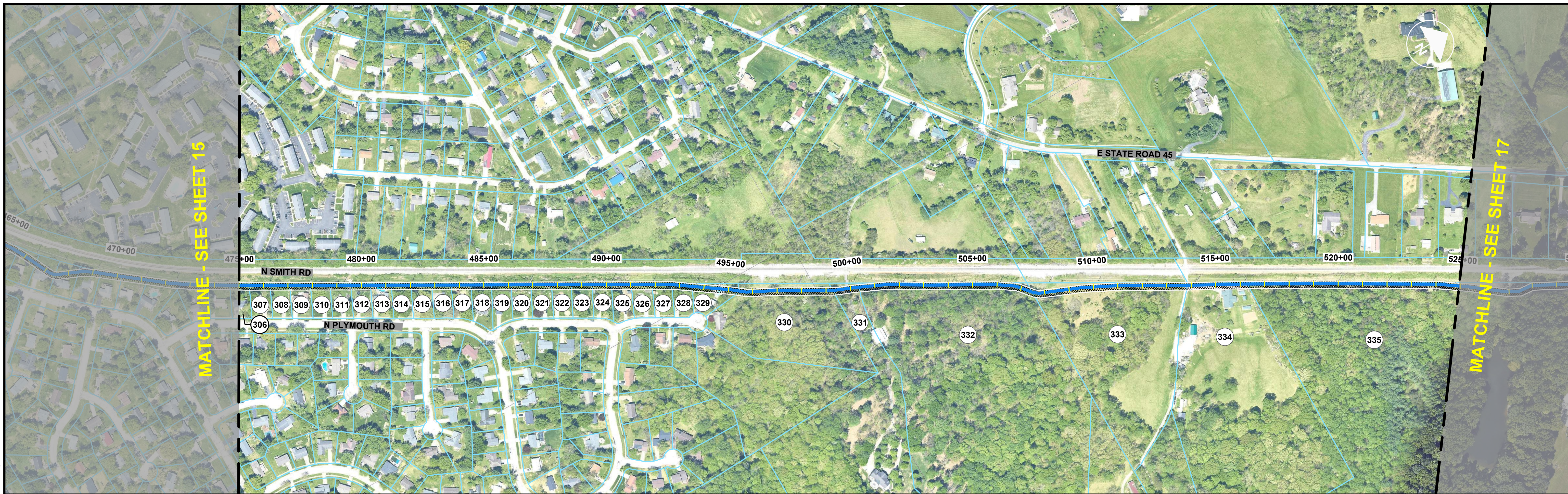

K:\7604.5142_8in_NS50565\0-Cover\7604.5142.0014\10_2024_3:28:13 PM - Last Saved: 11/16/2023 2:05:38 PM by DKEESLING; Last Plot: 1/10/2024 3:28:13 PM by JESSICA LAMB

NUMBER	OWNER NAME	PARCEL ID	EXISTING EASEMENT	PROPOSED PERMANENT	PROPOSED TEMPORARY
306	MCCOLLUM, PHILIP S & HEATHER R	53-05-36-301-003.000-005	Y	N	N
307	HOSTETTER, JAMES D & NELIA J	53-05-36-301-006.000-005	Y	N	N
308	SEREDA, VIKTORIIA E & SEREDA, YURIY	53-05-36-301-018.000-005	Y	N	N
309	ELLER, LARRY KEITH & DORIS ANN	53-05-36-301-016.000-005	Y	N	N
310	BOARDMAN, SHIRLEY MARIE	53-05-36-301-005.000-005	Y	N	N
311	MEETZ, RICHARD E & LOIS	53-05-36-301-017.001-005	Y	N	N
312	SCHUNN, JASON L & LAUREN M	53-05-36-301-011.000-005	Y	N	N
313	BACKLER, ALAN L & BARBARA J	53-05-36-301-019.000-005	Y	N	N
314	SALAHUDDIN, MOHAMMAD	53-05-36-206-016.000-005	Y	N	N
315	DUTTON, JEANNE ELLEN	53-05-36-206-022.000-005	Y	N	N
316	SURBURG, PAUL R & ELLEN N	53-05-36-206-019.000-005	Y	N	N
317	WAKHUNGU, HENRY KERRE & PHOEBE K	53-05-36-206-015.000-005	Y	N	N
318	TOTH, PAUL & PATRICIA K	53-05-36-206-021.000-005	Y	N	N
319	FRANK, KIMBERLY A	53-05-36-206-007.000-005	Y	N	N
320	STAMPER, SCOTT L & KRISTEN M	53-05-36-206-012.000-005	Y	N	N

NUMBER	OWNER NAME	PARCEL ID	EXISTING EASEMENT	PROPOSED PERMANENT	PROPOSED TEMPORARY
321	SMITH, BETTY JUNE TRUST	53-05-36-206-001.000-005	Y	N	N
322	MCELHINNEY, NYLE L	53-05-36-206-028.000-005	Y	N	N
323	THIAGARAJAN, SIVASAILAM ROJAN	53-05-36-204-008.000-005	Y	N	N
324	MULLIN, PAUL M & ELLEN J WALSH	53-05-36-204-007.000-005	Y	N	N
325	MANWORREN, NATHAN E	53-05-36-204-010.000-005	Y	N	N
326	BISPO DE JESUS, LUIZ ANDRE; HAMILTON, MARIA ELIZA	53-05-36-204-012.000-005	Y	N	N
327	SHAHER, THOMAS PAUL & JULIA	53-05-36-204-004.000-005	Y	N	N
328	LEBEAU, DAVID A. & NATALIE N.	53-05-36-204-003.000-005	Y	N	N
329	DEBRUICKER, LEANN R	53-05-36-204-009.000-005	Y	N	N
330	OPALEWSKI, ALEXANDER F	53-05-36-204-005.000-005	Y	N	N
331	GOLDSWORTHY, RICHARD CHARLES	53-05-36-100-004.000-004	Y	N	N
332	GOLDSWORTHY, RICHARD CHARLES	53-05-36-100-006.000-004	Y	N	N
333	NEAL, BETTY J REVOCABLE TRUST AGREEMENT W	53-05-25-400-006.000-004	Y	N	N
334	NEAL, JOHN ARTHUR	53-05-25-400-005.000-004	Y	N	N
335	MOORE, CARROLL W & DONNA L	53-05-25-400-010.000-004	Y	N	N



**RE-ISSUED FOR REVIEW
NOT FOR CONSTRUCTION
1/1X/2024**



NOTE:
DRAWINGS MAY HAVE BEEN ENLARGED OR REDUCED FROM THE ORIGINAL.
THE GRAPHIC SCALE IS PROVIDED FOR REFERENCE.

REVISIONS			
NO.	DATE	BY	DESCRIPTION
0	10/17/2023	TMP	ISSUED FOR BID
A	1/X/2024	JCS	RE-ISSUED FOR REVIEW

OPERATING CENTER: BLOOMINGTON	DIVISION: VEDIN
PROJECT#: 7604.5142	SCALE: 1" = 200'
CITY / TOWNSHIP: BLOOMINGTON	COUNTY: MONROE
STATE: IN	

8" NS5153 NEEDMORE TO UNIONVILLE PRESSURE TEST & RETROFIT GENERAL PARCEL MAP		
EnSiteUSA DWG NO. 0014	SHEET NO. SHEET 16	REV. A



DISCLAIMER: ENSITEUSA MAKES NO GUARANTEE THAT THIS SURVEY OR THESE MAPS CONTAINS COMPLETE OR CONCLUSIVE UNDERGROUND OR ABOVEGROUND UTILITY INFORMATION. THE CONTRACTOR IS RESPONSIBLE FOR VERIFYING THE LOCATION & PRESERVATION OF ALL UNDERGROUND AND ABOVEGROUND UTILITIES WHETHER OR NOT DEPICTED ON THESE DRAWINGS. THE CONTRACTOR IS TO CONTACT ALL OWNERS OF UNDERGROUND AND ABOVEGROUND UTILITIES PRIOR TO ANY EXCAVATION.

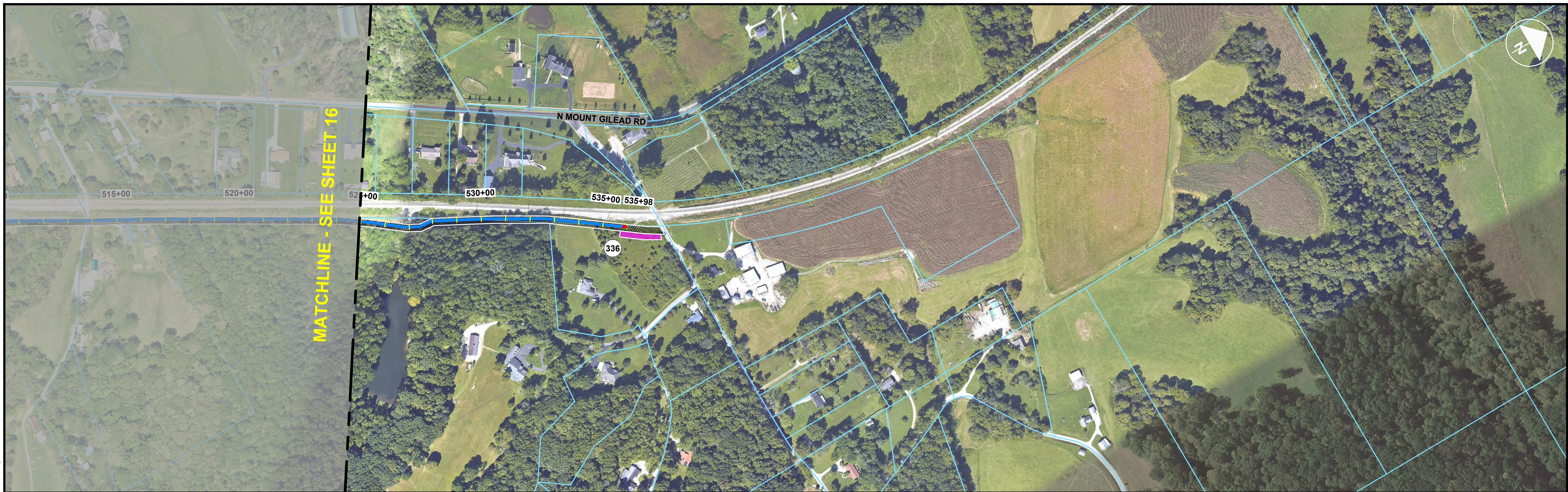

K:\7604_5142_Bin_NS5056\0-Cover\7604_5142_0016\1/10/2024_3:28:27 PM, Last Saved: 11/16/2023 2:05:40 PM by DKEESLING, Last Plot: 1/10/2024 3:28:27 PM by JESSICA LAWE

NUMBER	OWNER NAME	PARCEL ID	EXISTING EASEMENT	PROPOSED PERMANENT	PROPOSED TEMPORARY
336	MOORE, CARROLL W & DONNA L	53-05-25-400-015.000-004	Y	N	Y



**RE-ISSUED FOR REVIEW
NOT FOR CONSTRUCTION
1/X/2024**

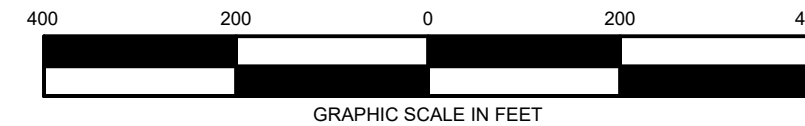

NOTE:
DRAWINGS MAY HAVE BEEN ENLARGED OR REDUCED FROM THE ORIGINAL.
THE GRAPHIC SCALE IS PROVIDED FOR REFERENCE.

REVISIONS			
NO.	DATE	BY	DESCRIPTION
0	10/17/2023	TMP	ISSUED FOR BID
A	1/X/2024	JCS	RE-ISSUED FOR REVIEW
----	----	----	----
----	----	----	----

OPERATING CENTER: BLOOMINGTON		DIVISION: VEDIN	
PROJECT#: 7604.5142	SCALE: 1" = 200'		
CITY / TOWNSHIP: BLOOMINGTON	COUNTY: MONROE	STATE: IN	

8" NS5153 NEEDMORE TO UNIONVILLE PRESSURE TEST & RETROFIT GENERAL PARCEL MAP		
EnSiteUSA DWG NO. 0016	SHEET NO. SHEET 17	REV. A



DISCLAIMER: ENSITEUSA MAKES NO GUARANTEE THAT THIS SURVEY OR THESE MAPS CONTAINS COMPLETE OR CONCLUSIVE UNDERGROUND OR ABOVEGROUND UTILITY INFORMATION. THE CONTRACTOR IS RESPONSIBLE FOR VERIFYING THE LOCATION & PRESERVATION OF ALL UNDERGROUND AND ABOVEGROUND UTILITIES WHETHER OR NOT DEPICTED ON THESE DRAWINGS. THE CONTRACTOR IS TO CONTACT ALL OWNERS OF UNDERGROUND AND ABOVEGROUND UTILITIES PRIOR TO ANY EXCAVATION.

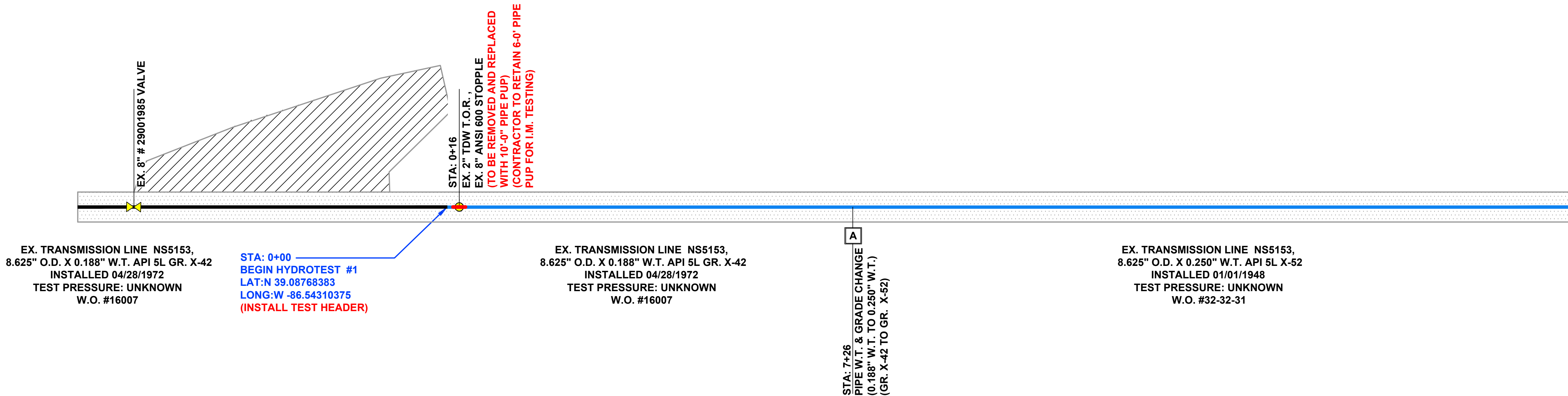
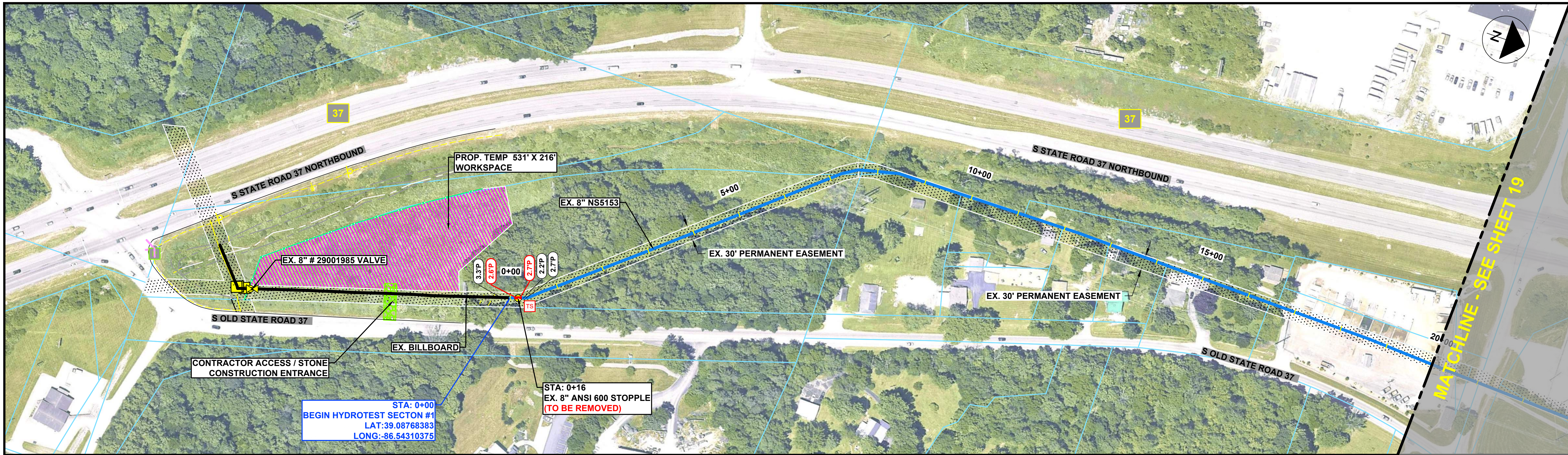

A 8.625" O.D. X 0.250" W.T. API 5L GR. X-52
DATE INSTALLED: 01/01/1948
TEST PRESSURE: UNKNOWN
WO# 32-32-31



NOTE: DRAWINGS MAY HAVE BEEN ENLARGED OR REDUCED FROM THE ORIGINAL. THE GRAPHIC SCALE IS PROVIDED FOR REFERENCE.

REVISIONS			
NO.	DATE	BY	DESCRIPTION
C	9/8/2023	JCS	ISSUED FOR 90% REVIEW
0	10/17/2023	JCS	ISSUED FOR BID
0A	10/31/2023	JCS	RE-ISSUED FOR BID
D	1/1/2024	JCS	RE-ISSUED FOR REVIEW

OPERATING CENTER: BLOOMINGTON	DIVISION: VEDIN
PROJECT#: 7604.5142	SCALE: 1" = 100'
CITY / TOWNSHIP: BLOOMINGTON	COUNTY: MONROE
STATE: IN	

8" NS5153 NEEDMORE TO UNIONVILLE PRESSURE TEST & RETROFIT PIPELINE ALIGNMENT		
EnSiteUSA DWG NO. 1000	SHEET NO. SHEET 18	REV. D



**RE-ISSUED FOR REVIEW
NOT FOR CONSTRUCTION
1/X/2024**



K:\7604.5142_BM_NS50561-PLU\7604.5142_1000\11022024_3.32.13 PM.dwg 11/02/2024 3:32:13 PM by DWESLUNG; Last Plot: 11/02/2024 3:32:13 PM by JESSICA LAMB

DISCLAIMER: ENSITEUSA MAKES NO GUARANTEE THAT THIS SURVEY OR THESE MAPS CONTAINS COMPLETE OR CONCLUSIVE UNDERGROUND OR ABOVEGROUND UTILITY INFORMATION. THE CONTRACTOR IS RESPONSIBLE FOR VERIFYING THE LOCATION & PRESERVATION OF ALL UNDERGROUND AND ABOVEGROUND UTILITIES WHETHER OR NOT DEPICTED ON THESE DRAWINGS. THE CONTRACTOR IS TO CONTACT ALL OWNERS OF UNDERGROUND AND ABOVEGROUND UTILITIES PRIOR TO ANY EXCAVATION.

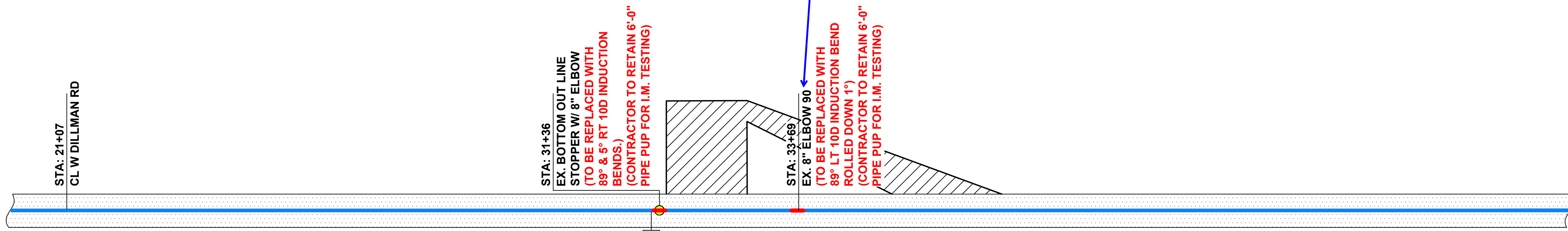
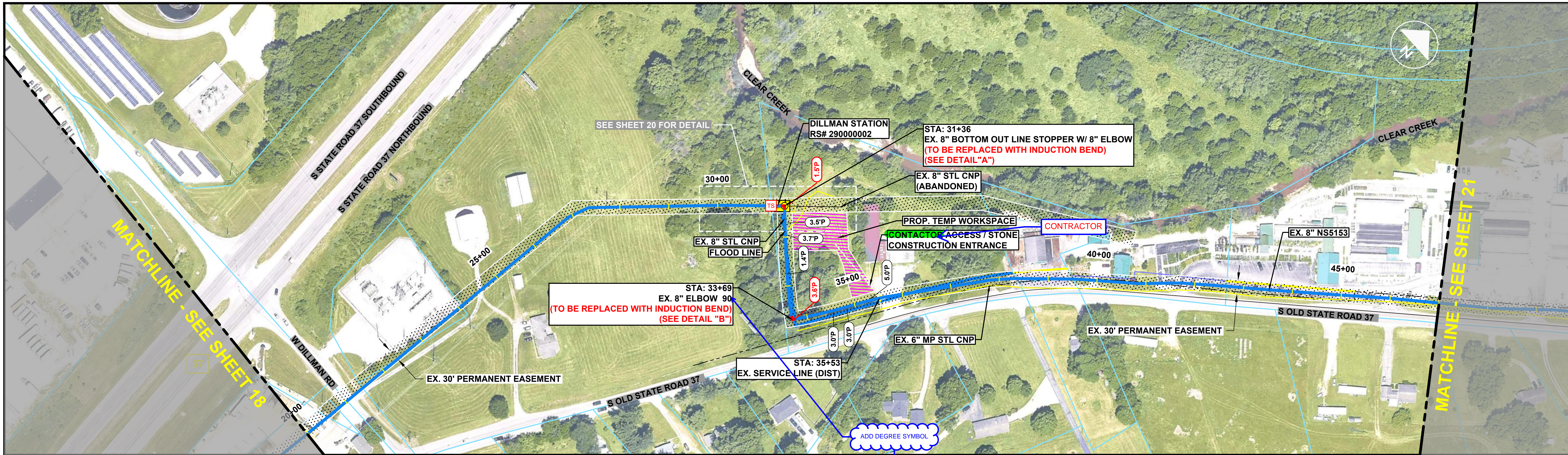

EX. TRANSMISSION LINE NS5153,
8.625" O.D. X 0.250" W.T. API 5L GR. X-52
INSTALLED 01/01/1948
TEST PRESSURE: UNKNOWN
W.O. # 32-32-31

EX. TRANSMISSION LINE NS5153,
8.625" O.D. X 0.250" W.T. API 5L GR. B
INSTALLED 01/20/2015
TEST PRESSURE: 1115 PSIG
W.O. 13592402050213

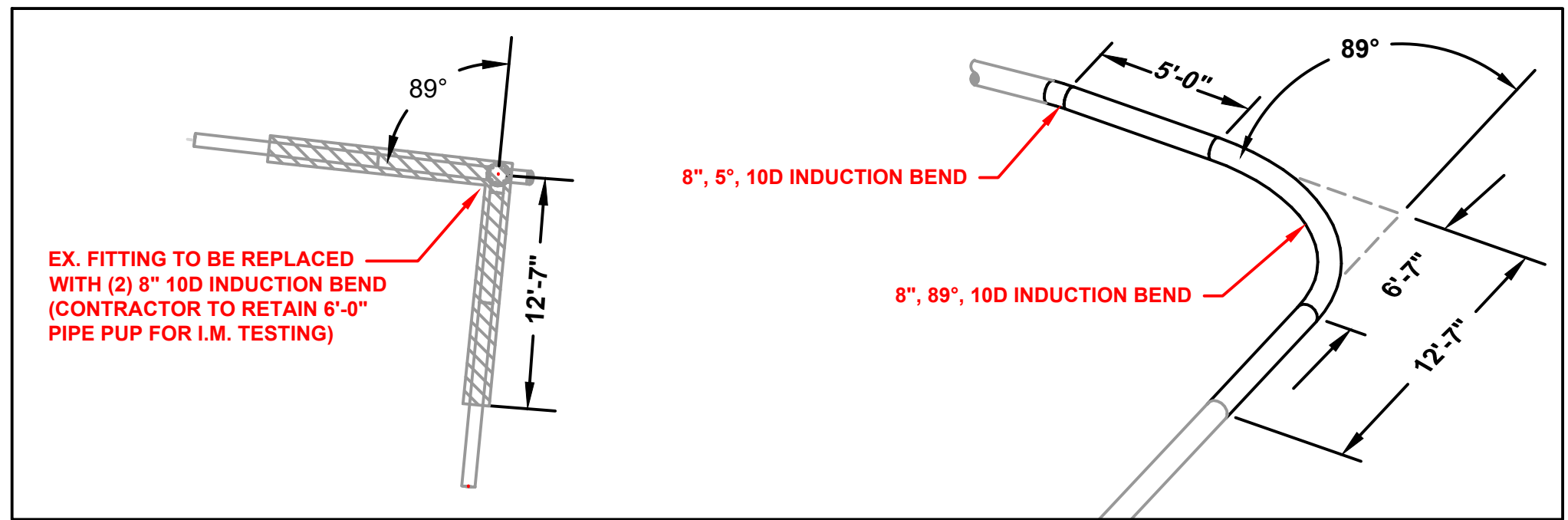

RETIREMENT PLAN

DETAIL A
SCALE: 1" = 8'

INSTALLATION PLAN

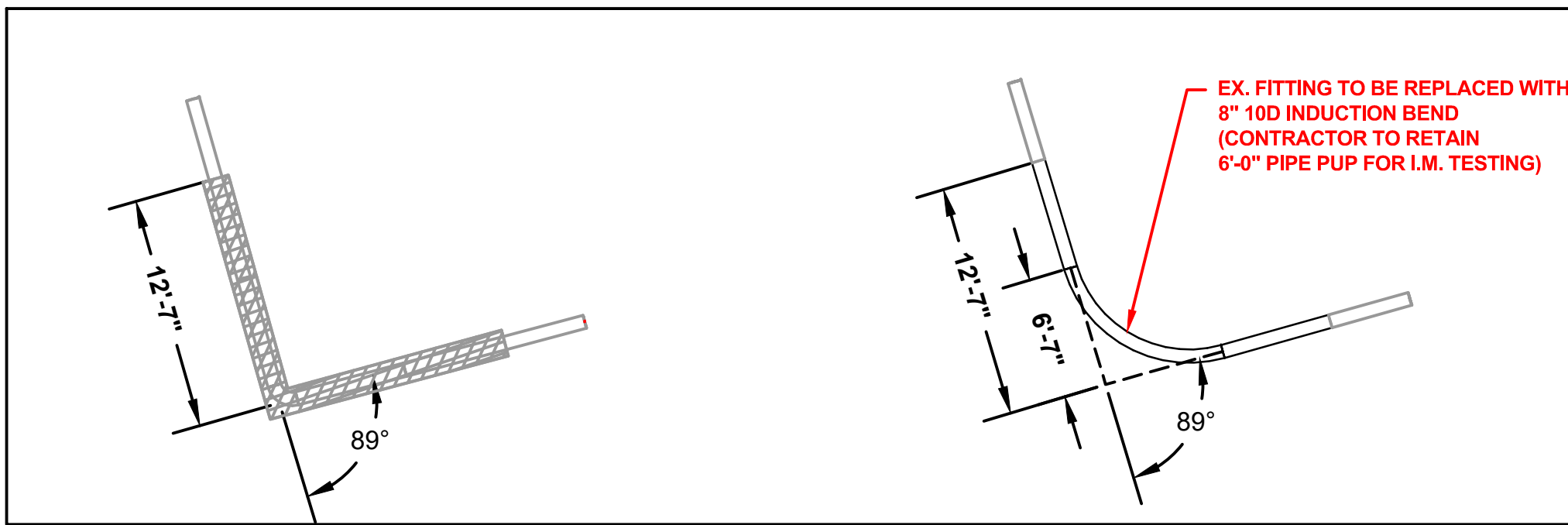

RETIREMENT PLAN

DETAIL B
SCALE: 1" = 8'

INSTALLATION PLAN

A 8.625" O.D. X 0.250" W.T. API 5L GR. X-52
DATE INSTALLED: 01/01/1948
TEST PRESSURE: UNKNOWN
WO# 32-32-31

	<div style="border: 2px solid red; padding: 5px; color: red; text-align: center;"> RE-ISSUED FOR REVIEW NOT FOR CONSTRUCTION 1/1/2024 </div>			REVISIONS		OPERATING CENTER:	DIVISION:	8" NS5153 NEEDMORE TO UNIONVILLE PRESSURE TEST & RETROFIT PIPELINE ALIGNMENT				
				NO.	DATE	BY	DESCRIPTION					BLOOMINGTON
<small>NOTE: DRAWINGS MAY HAVE BEEN ENLARGED OR REDUCED FROM THE ORIGINAL. THE GRAPHIC SCALE IS PROVIDED FOR REFERENCE.</small>				C	9/8/2023	JCS	ISSUED FOR 90% REVIEW	PROJECT#:	SCALE:	EnSiteUSA DWG NO. 1001 SHEET NO. 19 REV. D		
				0	10/17/2023	JCS	ISSUED FOR BID	7604.5142	1" = 100'			
<small>DISCLAIMER: ENSITEUSA MAKES NO GUARANTEE THAT THIS SURVEY OR THESE MAPS CONTAINS COMPLETE OR CONCLUSIVE UNDERGROUND OR ABOVEGROUND UTILITY INFORMATION. THE CONTRACTOR IS RESPONSIBLE FOR VERIFYING THE LOCATION & PRESERVATION OF ALL UNDERGROUND AND ABOVEGROUND UTILITIES WHETHER OR NOT DEPICTED ON THESE DRAWINGS. THE CONTRACTOR IS TO CONTACT ALL OWNERS OF UNDERGROUND AND ABOVEGROUND UTILITIES PRIOR TO ANY EXCAVATION.</small>				0A	10/31/2023	JCS	RE-ISSUED FOR BID	CITY / TOWNSHIP:	COUNTY:	STATE:		
				D	1/1/2024	JCS	RE-ISSUED FOR REVIEW	BLOOMINGTON	MONROE	IN		

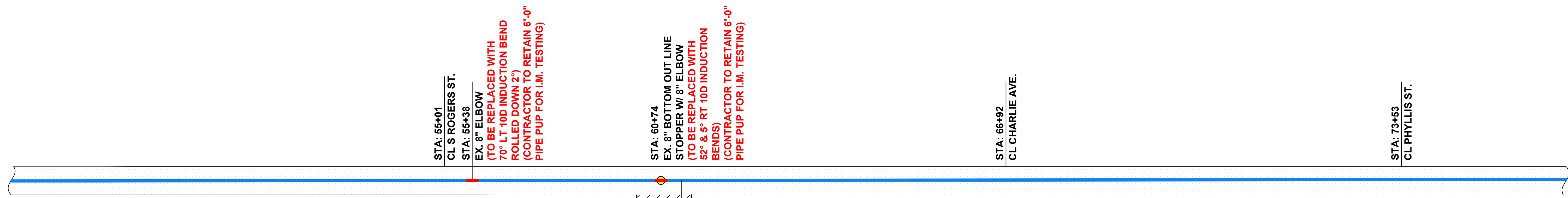
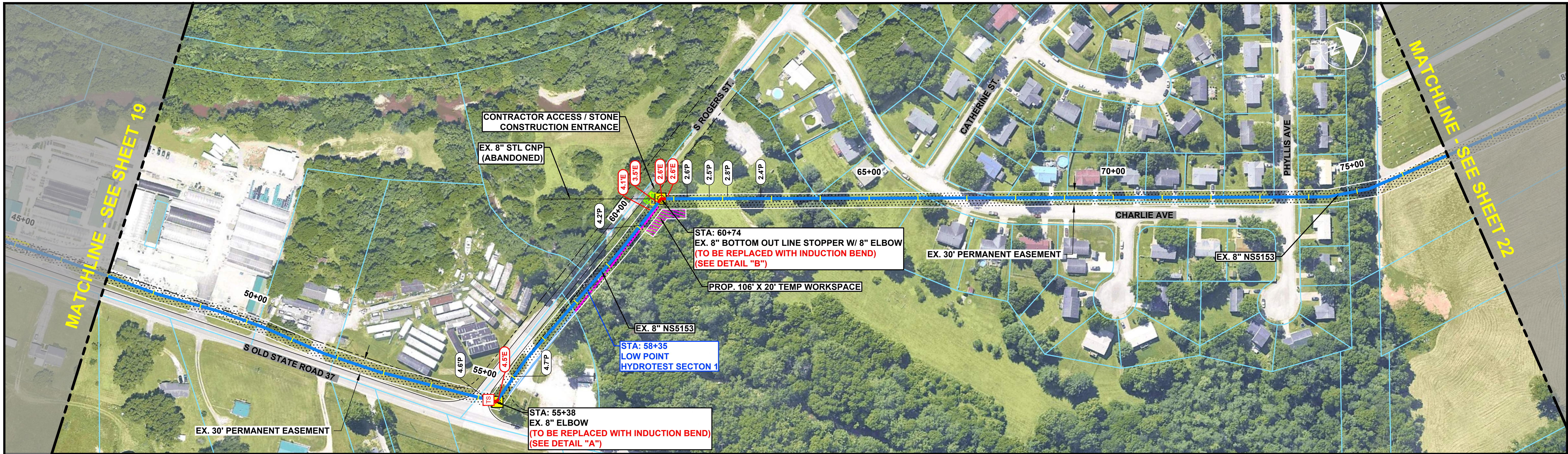

EX. TRANSMISSION LINE NS5153,
8.625" O.D. X 0.250" W.T. API 5L GR. B
INSTALLED 01/20/2015
TEST PRESSURE: 1115 PSIG
W.O. #13592402050213

EX. TRANSMISSION LINE NS5153,
8.625" O.D. X 0.250" W.T. API 5L GR. X-52
INSTALLED 12/31/1947
TEST PRESSURE: UNKNOWN
W.O. #32-32-31

EX. FITTING TO BE REPLACED WITH 8" 10D INDUCTION BEND
(CONTRACTOR TO RETAIN 6'-0" PIPE PUP FOR I.M. TESTING)

EX. FITTING TO BE REPLACED WITH (2) 8" 10D INDUCTION BEND
(CONTRACTOR TO RETAIN 6'-0" PIPE PUP FOR I.M. TESTING)

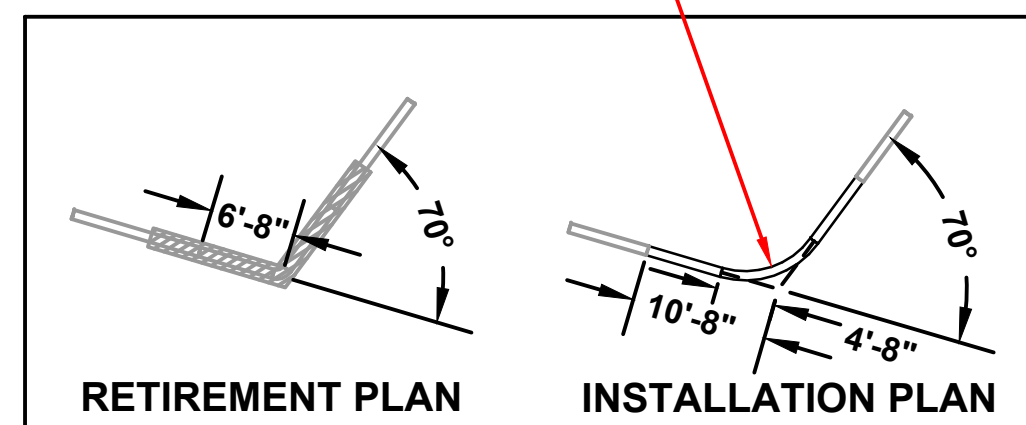

DETAIL A
SCALE: 1" = 15'

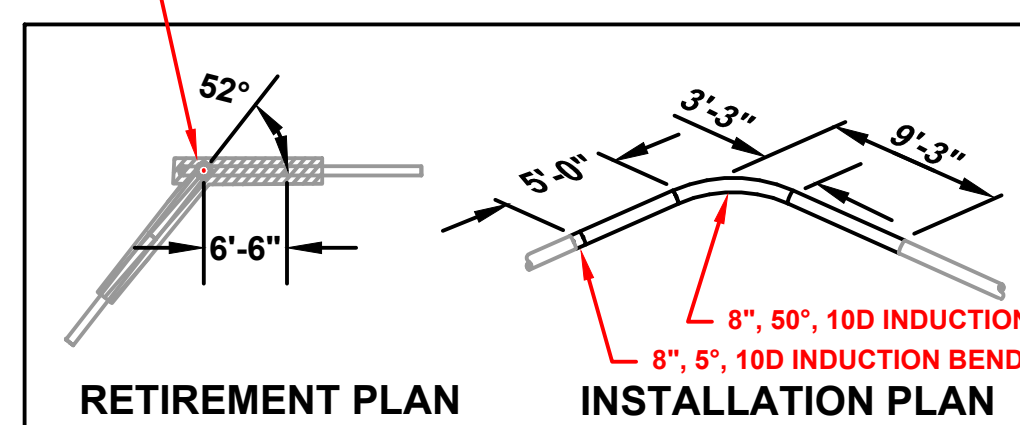

DETAIL B
SCALE: 1" = 15'

8", 89°, 10D INDUCTION BEND

A 8.625" O.D. X 0.250" W.T. API 5L GR. B
DATE INSTALLED: 01/20/2015
TEST PRESSURE: UNKNOWN
W.O. #13592402050213



**RE-ISSUED FOR REVIEW
NOT FOR CONSTRUCTION
1/1/2024**

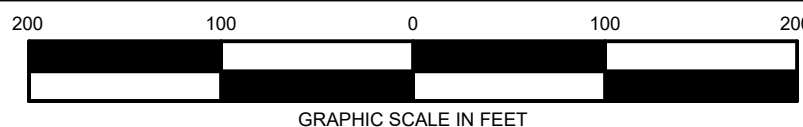

NOTE: DRAWINGS MAY HAVE BEEN ENLARGED OR REDUCED FROM THE ORIGINAL. THE GRAPHIC SCALE IS PROVIDED FOR REFERENCE.

REVISIONS			
NO.	DATE	BY	DESCRIPTION
B	9/8/2023	JCS	ISSUED FOR 90% REVIEW
0	10/17/2023	JCS	ISSUED FOR BID
0A	10/31/2023	JCS	RE-ISSUED FOR BID
C	1/1/2024	JCS	RE-ISSUED FOR REVIEW

OPERATING CENTER: BLOOMINGTON	DIVISION: VEDIN
PROJECT#: 7604.5142	SCALE: 1" = 100'
CITY / TOWNSHIP: BLOOMINGTON	COUNTY: MONROE
STATE: IN	

8" NS5153 NEEDMORE TO UNIONVILLE PRESSURE TEST & RETROFIT PIPELINE ALIGNMENT		
EnSiteUSA DWG NO. 1002	SHEET NO. 21	REV. C



DISCLAIMER: ENSITEUSA MAKES NO GUARANTEE THAT THIS SURVEY OR THESE MAPS CONTAINS COMPLETE OR CONCLUSIVE UNDERGROUND OR ABOVEGROUND UTILITY INFORMATION. THE CONTRACTOR IS RESPONSIBLE FOR VERIFYING THE LOCATION & PRESERVATION OF ALL UNDERGROUND AND ABOVEGROUND UTILITIES WHETHER OR NOT DEPICTED ON THESE DRAWINGS. THE CONTRACTOR IS TO CONTACT ALL OWNERS OF UNDERGROUND AND ABOVEGROUND UTILITIES PRIOR TO ANY EXCAVATION.

K:\7604.5142_BM_NS50561-FULL\7604.5142_1002\11022024_3.39.47 PM.dwg by CBJESS, Last Pld: 11/02/2024 3:39:47 PM by JESSICA LAMB

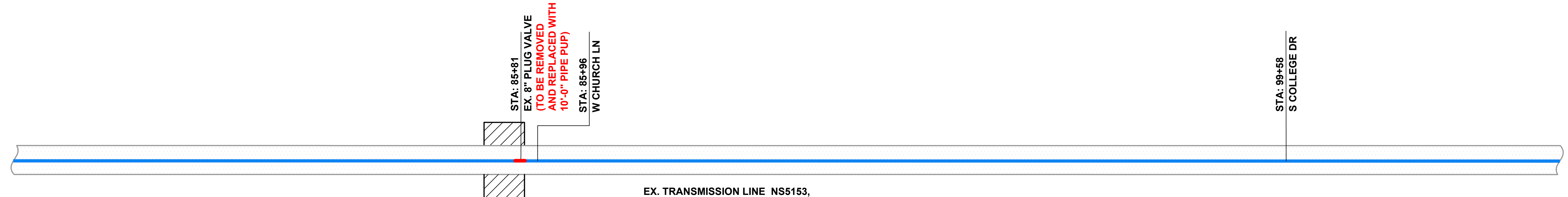
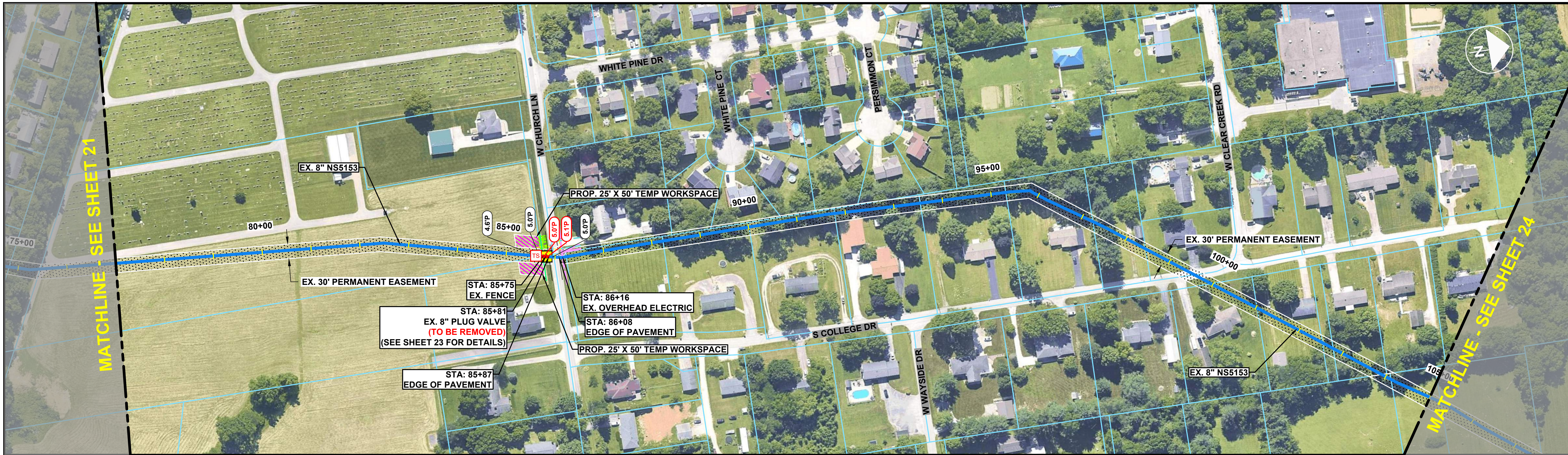

EX. TRANSMISSION LINE NS5153,
 8.625" O.D. X 0.250" W.T. API 5L GR. X-52
 INSTALLED 12/31/1947
 TEST PRESSURE: UNKNOWN
 W.O. # 32-32-31

K:\7604-5142-00-NS50561-PLU\7604-5142-1004\11/02/2023 9:14:50 AM by DWESLING; Last Plot: 1/10/2024 3:34:06 PM by JESSICA LAMB



**RE-ISSUED FOR REVIEW
 NOT FOR CONSTRUCTION
 1/X/2024**

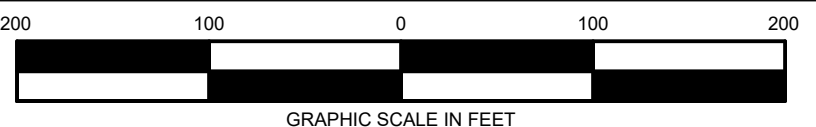

NOTE:
 DRAWINGS MAY HAVE BEEN ENLARGED OR REDUCED FROM THE ORIGINAL.
 THE GRAPHIC SCALE IS PROVIDED FOR REFERENCE.

REVISIONS			
NO.	DATE	BY	DESCRIPTION
C	9/8/2023	JCS	ISSUED FOR 90% REVIEW
0	10/17/2023	JCS	ISSUED FOR BID
0A	10/31/2023	JCS	RE-ISSUED FOR BID
D	1/X/2024	JCS	RE-ISSUED FOR REVIEW

OPERATING CENTER: BLOOMINGTON		DIVISION: VEDIN	
PROJECT#: 7604.5142	SCALE: 1" = 100'		
CITY / TOWNSHIP: BLOOMINGTON	COUNTY: MONROE	STATE: IN	

8" NS5153 NEEDMORE TO UNIONVILLE PRESSURE TEST & RETROFIT PIPELINE ALIGNMENT			
EnSiteUSA DWG NO. 1004	SHEET NO. SHEET 22	REV. D	



DISCLAIMER: ENSITEUSA MAKES NO GUARANTEE THAT THIS SURVEY OR THESE MAPS CONTAINS COMPLETE OR CONCLUSIVE UNDERGROUND OR ABOVEGROUND UTILITY INFORMATION. THE CONTRACTOR IS RESPONSIBLE FOR VERIFYING THE LOCATION & PRESERVATION OF ALL UNDERGROUND AND ABOVEGROUND UTILITIES WHETHER OR NOT DEPICTED ON THESE DRAWINGS. THE CONTRACTOR IS TO CONTACT ALL OWNERS OF UNDERGROUND AND ABOVEGROUND UTILITIES PRIOR TO ANY EXCAVATION.

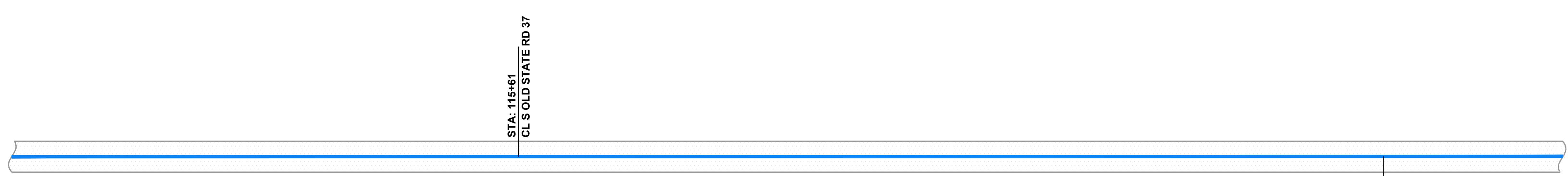

EX. TRANSMISSION LINE NS5153,
 8.625" O.D. X 0.250" W.T. API 5L GR. X-52
 INSTALLED 12/31/1947
 TEST PRESSURE: UNKNOWN
 W.O. #32-32-31

A
 STA: 129+89 - 130+01
 PIPE W.T. & GRADE CHANGE
 (0.250" W.T. TO 0.188" W.T.)
 (GR. X-52 TO GR. X-42)

A 8.625" O.D. x 0.188" W.T. API 5L GR. X-42
 DATE INSTALLED: 01-01-1987
 TEST PRESSURE: UNKNOWN
 (WO# 32-32-31)

K:\7604-5142-86-NS50561-PL\7604-5142-1006\11022024-3-24-24-PM.Lst Saved 11/02/2023 12:38:51 PM by TPOLEN, Last Pnt 1/10/2024 3:24:24 PM by JESSICA LAMB



RE-ISSUED FOR REVIEW
 NOT FOR CONSTRUCTION
 1/1/2024



NOTE:
 DRAWINGS MAY HAVE BEEN ENLARGED OR REDUCED FROM THE ORIGINAL.
 THE GRAPHIC SCALE IS PROVIDED FOR REFERENCE.

REVISIONS			
NO.	DATE	BY	DESCRIPTION
B	07/24/2023	JCS	ISSUED FOR 60% REVIEW
C	9/8/2023	JCS	ISSUED FOR 90% REVIEW
0	10/17/2023	JCS	ISSUED FOR BID
D	1/1/2024	JCS	RE-ISSUED FOR REVIEW

OPERATING CENTER: BLOOMINGTON	DIVISION: VEDIN
PROJECT#: 7604.5142	SCALE: 1" = 100'
CITY / TOWNSHIP: BLOOMINGTON	COUNTY: MONROE
STATE: IN	

8" NS5153 NEEDMORE TO UNIONVILLE PRESSURE TEST & RETROFIT PIPELINE ALIGNMENT		
EnSiteUSA DWG NO. 1006	SHEET NO. SHEET 24	REV. D



DISCLAIMER: ENSITEUSA MAKES NO GUARANTEE THAT THIS SURVEY OR THESE MAPS CONTAINS COMPLETE OR CONCLUSIVE UNDERGROUND OR ABOVEGROUND UTILITY INFORMATION. THE CONTRACTOR IS RESPONSIBLE FOR VERIFYING THE LOCATION & PRESERVATION OF ALL UNDERGROUND AND ABOVEGROUND UTILITIES WHETHER OR NOT DEPICTED ON THESE DRAWINGS. THE CONTRACTOR IS TO CONTACT ALL OWNERS OF UNDERGROUND AND ABOVEGROUND UTILITIES PRIOR TO ANY EXCAVATION.

Monroe Wis to south of W Gordon Road,
Bloomington MS4 to north
YL - SWPPP notes

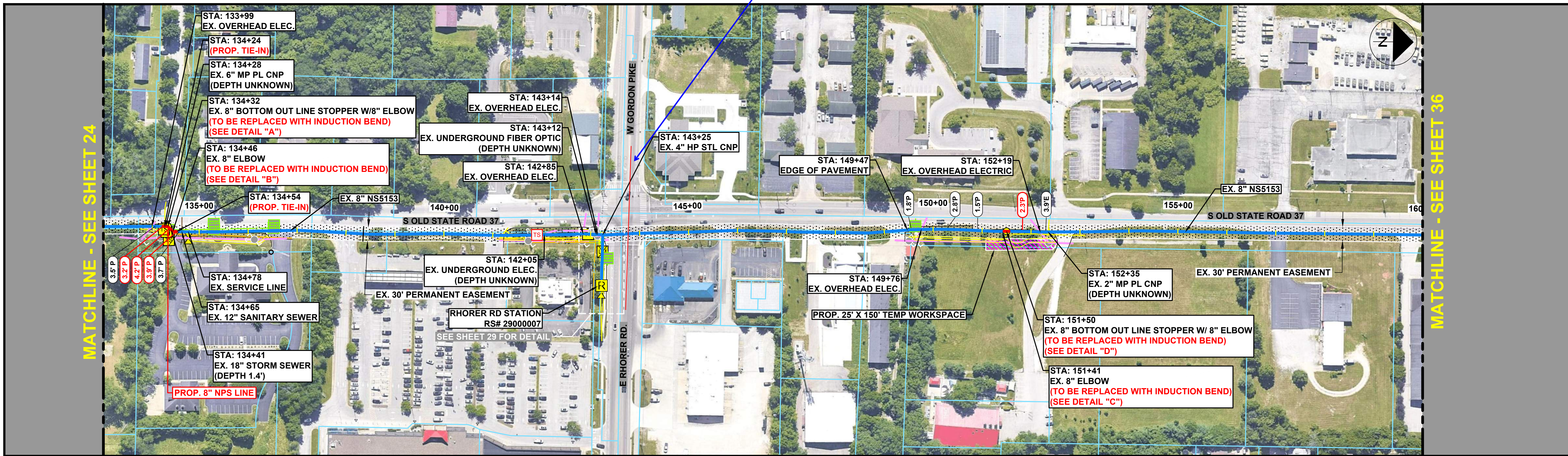

MATCHLINE - SEE SHEET 24

MATCHLINE - SEE SHEET 36

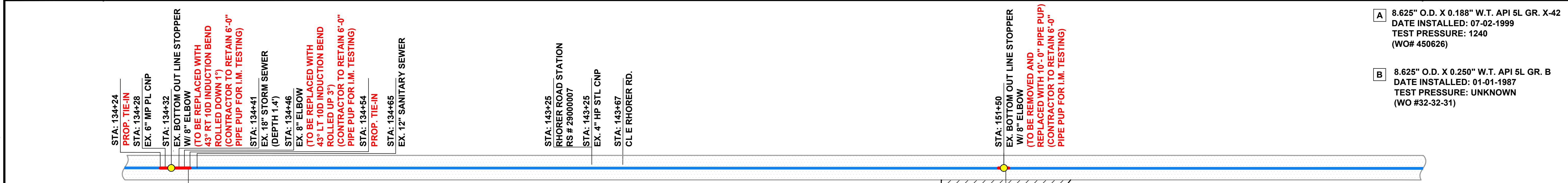

- A** 8.625" O.D. X 0.188" W.T. API 5L GR. X-42
DATE INSTALLED: 07-02-1999
TEST PRESSURE: 1240
(WO# 450626)
- B** 8.625" O.D. X 0.250" W.T. API 5L GR. B
DATE INSTALLED: 01-01-1987
TEST PRESSURE: UNKNOWN
(WO #32-32-31)

EX. TRANSMISSION LINE NS5153, 8.625" O.D. X 0.250" W.T. API 5L X-52
INSTALLED 6/15/1999
TEST PRESSURE: UNKNOWN
W.O. #32-32-31, 450626

STA: 134+48
PIPE W.T. & GRADE CHANGE
(0.250" W.T. TO 0.188" W.T.)
(GR. X-52 TO GR. X-42)

EX. TRANSMISSION LINE NS5153, 8.625" O.D. X 0.188" W.T. API 5L GR. X-42
INSTALLED 7/2/1999
TEST PRESSURE: 1240
W.O. #450626

STA: 151+51
PIPE W.T. & GRADE CHANGE
(0.188" W.T. TO 0.250" W.T.)
(GR. X-42 TO GR. B)

EX. TRANSMISSION LINE NS5153, 8.625" O.D. X 0.250" W.T. API 5L GR. B
INSTALLED 01/01/1987
TEST PRESSURE: UNKNOWN
W.O. #32-32-31

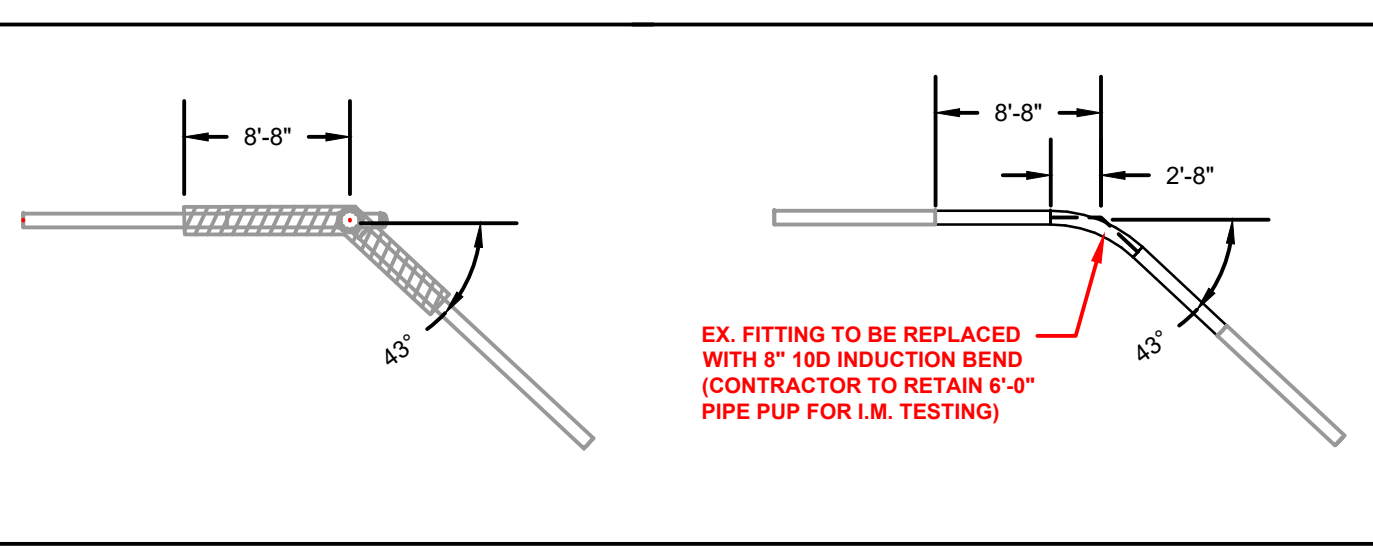

DETAIL A
SCALE: 1" = 10'

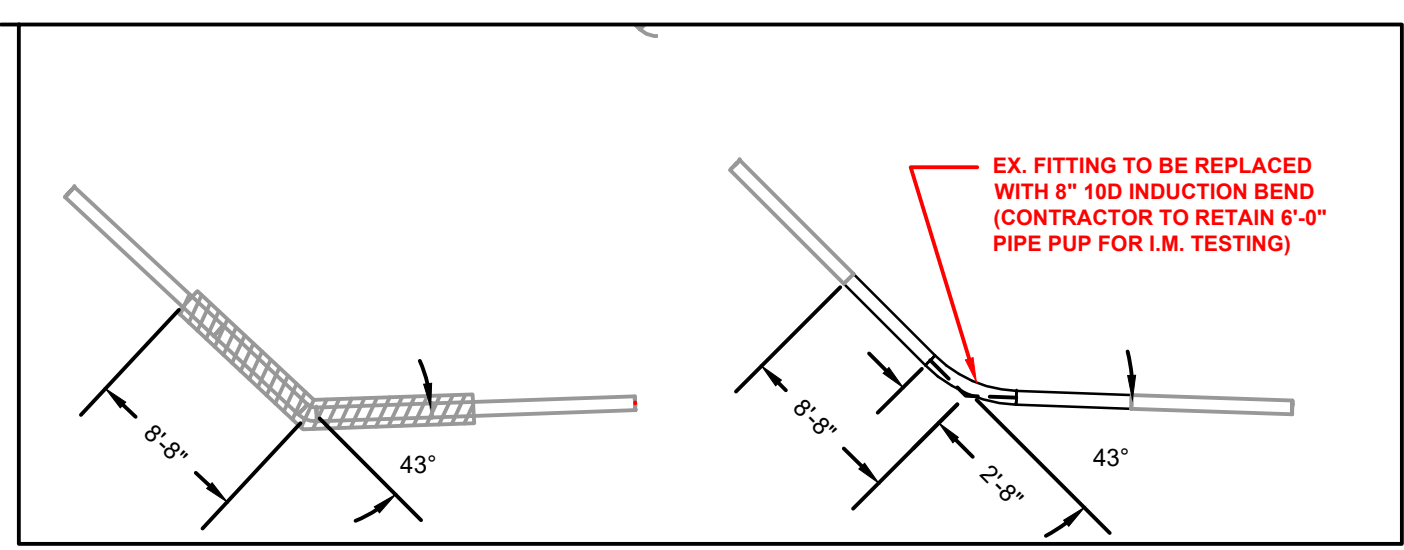

DETAIL B
SCALE: 1" = 10'

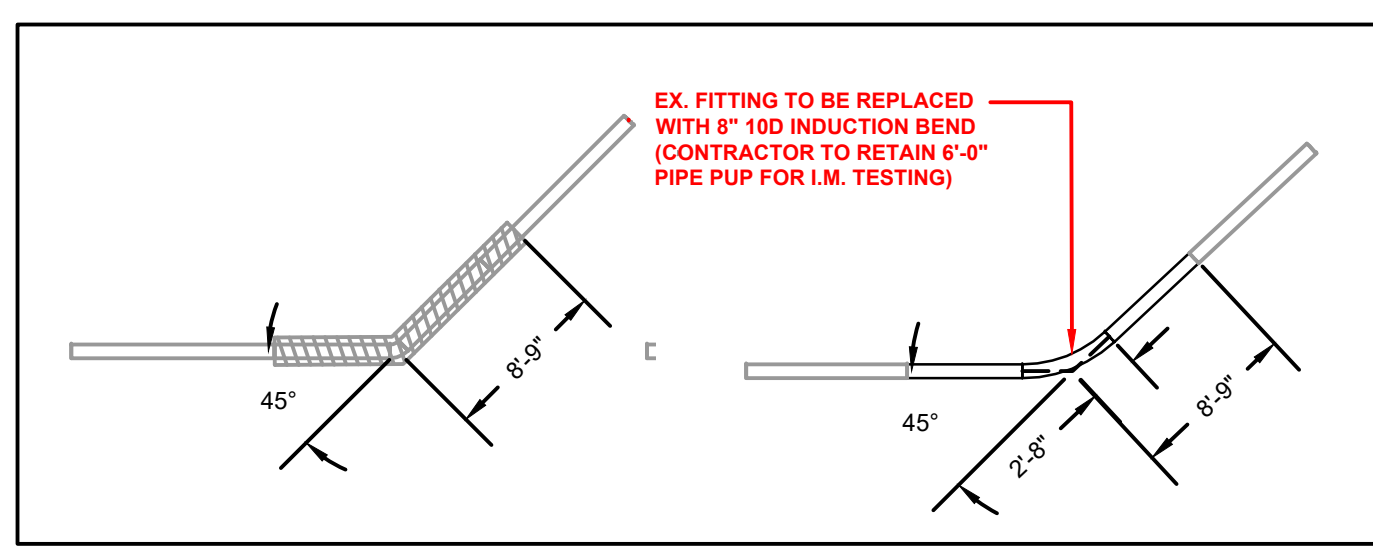

DETAIL C
SCALE: 1" = 10'

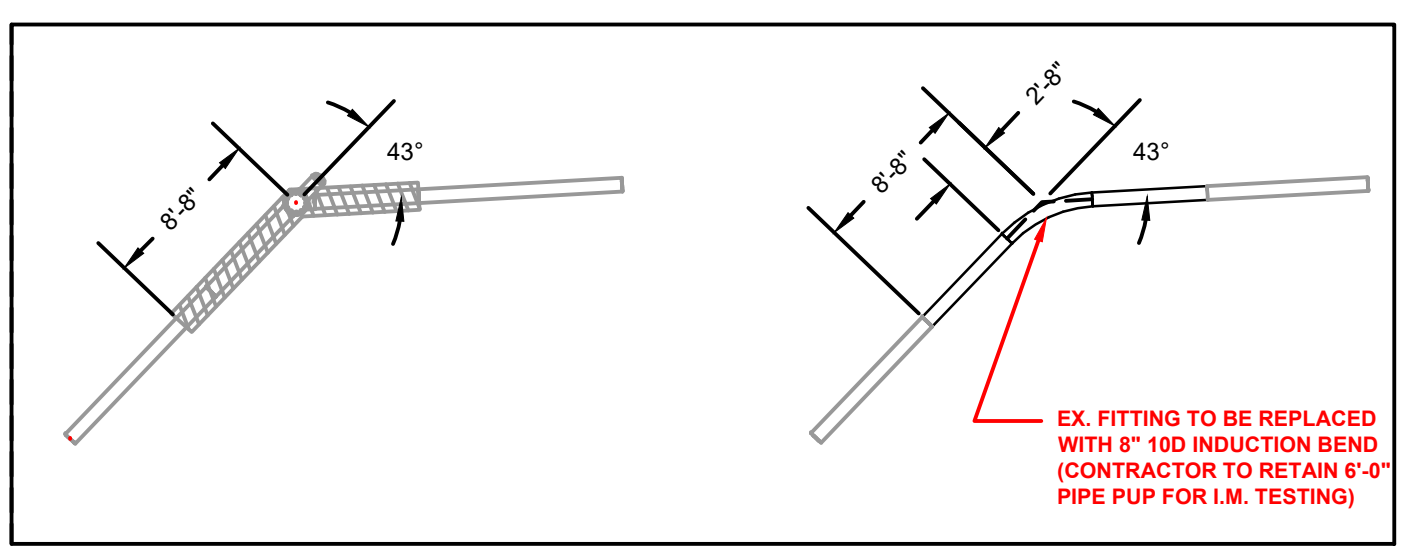

DETAIL D
SCALE: 1" = 10'



RE-ISSUED FOR REVIEW
NOT FOR CONSTRUCTION
1/1/2024

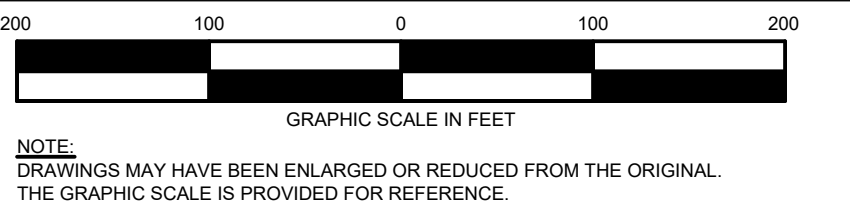

REVISIONS		
NO.	DATE	DESCRIPTION
C	9/8/2023	JCS ISSUED FOR 90% REVIEW
0	10/17/2023	JCS ISSUED FOR BID
0A	10/31/2023	JCS RE-ISSUED FOR BID
D	1/1/2024	JCS RE-ISSUED FOR REVIEW

OPERATING CENTER: BLOOMINGTON	DIVISION: VEDIN
PROJECT#: 7604.5142	SCALE: 1" = 100'
CITY / TOWNSHIP: BLOOMINGTON	COUNTY: MONROE
STATE: IN	

8" NS5153 NEEDMORE TO UNIONVILLE PRESSURE TEST & RETROFIT PIPELINE ALIGNMENT		
EnSiteUSA DWG NO. 1007	SHEET NO. 25	REV. D



DISCLAIMER: ENSITEUSA MAKES NO GUARANTEE THAT THIS SURVEY OR THESE MAPS CONTAINS COMPLETE OR CONCLUSIVE UNDERGROUND OR ABOVEGROUND UTILITY INFORMATION. THE CONTRACTOR IS RESPONSIBLE FOR VERIFYING THE LOCATION & PRESERVATION OF ALL UNDERGROUND AND ABOVEGROUND UTILITIES WHETHER OR NOT DEPICTED ON THESE DRAWINGS. THE CONTRACTOR IS TO CONTACT ALL OWNERS OF UNDERGROUND AND ABOVEGROUND UTILITIES PRIOR TO ANY EXCAVATION.

K:\7604.5142_Bn_NS50661-PLU17604.5142_100711022024_3.35.16 PM.Lnk Saved 11/17/2023 9:15:12 AM by DWESLING; Lnk Pk: 1/10/2024 3:35:16 PM by JESSICA LAMB

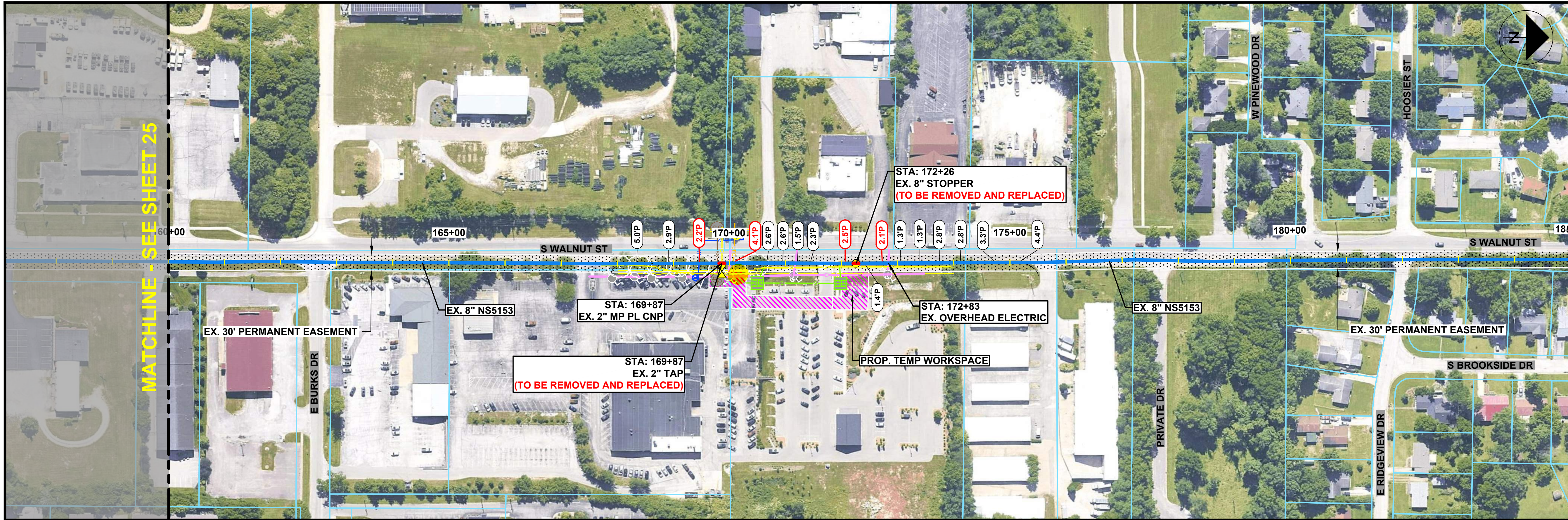

MATCHLINE - SEE SHEET 25

MATCHLINE - SEE SHEET 37

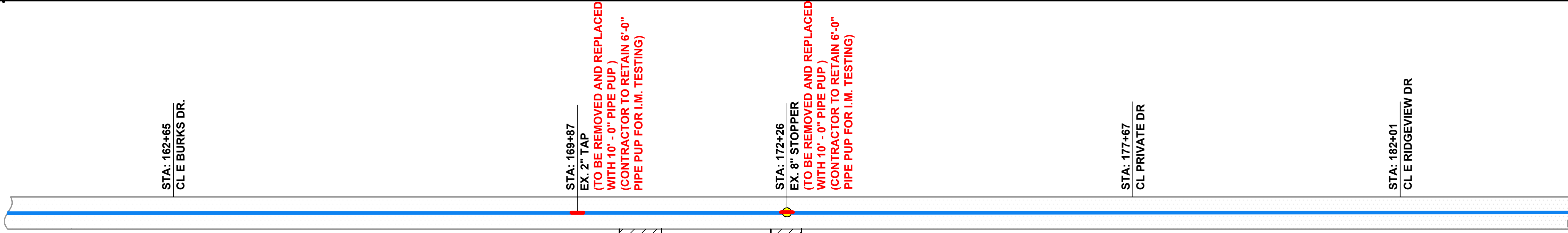

EX. TRANSMISSION LINE NS5153,
8.625" O.D. X 0.250" W.T. API 5L GR. B
INSTALLED 01/01/1987
TEST PRESSURE: UNKNOWN
W.O. #32-32-31

K:\7604-5142-00-NS50561-PLU\7604-5142-1008\11022024-3-35-35 PM, Last Saved 12/27/2023 11:23:09 AM by TPOLLEN, Last Plot 11/02/2024 3:35:35 PM by JESSICA LAMB



RE-ISSUED FOR REVIEW
NOT FOR CONSTRUCTION
1/1/2024

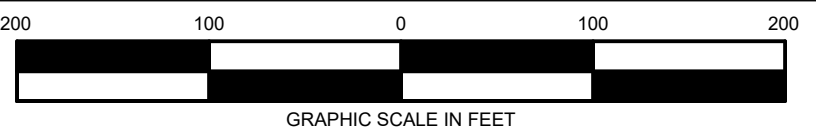

NOTE:
DRAWINGS MAY HAVE BEEN ENLARGED OR REDUCED FROM THE ORIGINAL.
THE GRAPHIC SCALE IS PROVIDED FOR REFERENCE.

REVISIONS			
NO.	DATE	BY	DESCRIPTION
C	9/8/2023	CAG	ISSUED FOR 90% REVIEW
0	10/17/2023	JCS	ISSUED FOR BID
0A	10/31/2023	JCS	RE-ISSUED FOR BID
D	1/1/2024	JCS	RE-ISSUED FOR REVIEW

OPERATING CENTER: BLOOMINGTON	DIVISION: VEDIN
PROJECT#: 7604.5142	SCALE: 1" = 100'
CITY / TOWNSHIP: BLOOMINGTON	COUNTY: MONROE
STATE: IN	

8" NS5153 NEEDMORE TO UNIONVILLE PRESSURE TEST & RETROFIT PIPELINE ALIGNMENT		
EnSiteUSA DWG NO. 1008	SHEET NO. SHEET 36	REV. D



DISCLAIMER: ENSITEUSA MAKES NO GUARANTEE THAT THIS SURVEY OR THESE MAPS CONTAINS COMPLETE OR CONCLUSIVE UNDERGROUND OR ABOVEGROUND UTILITY INFORMATION. THE CONTRACTOR IS RESPONSIBLE FOR VERIFYING THE LOCATION & PRESERVATION OF ALL UNDERGROUND AND ABOVEGROUND UTILITIES WHETHER OR NOT DEPICTED ON THESE DRAWINGS. THE CONTRACTOR IS TO CONTACT ALL OWNERS OF UNDERGROUND AND ABOVEGROUND UTILITIES PRIOR TO ANY EXCAVATION.



SCHEMATIC

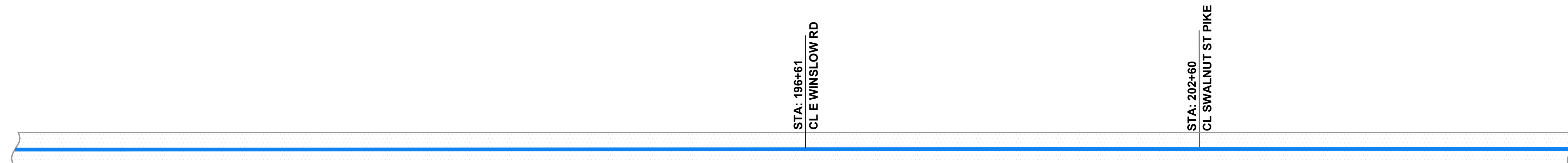

EX. TRANSMISSION LINE NS5153,
 8.625" O.D. X 0.250" W.T. API 5L GR. B
 INSTALLED 01/01/1987
 TEST PRESSURE: UNKNOWN
 W.O. #32-32-31

K:\7604-5142-00-NS50661-PL\7604-5142-10\11022024-3-35-50 PM.dwg by JESSICA LAMB 11/17/2023 9:36:29 AM by DWESLING: Last Plot: 1/10/2024 3:35:50 PM by JESSICA LAMB



**RE-ISSUED FOR REVIEW
 NOT FOR CONSTRUCTION
 1/X/2024**



NOTE:
 DRAWINGS MAY HAVE BEEN ENLARGED OR REDUCED FROM THE ORIGINAL.
 THE GRAPHIC SCALE IS PROVIDED FOR REFERENCE.

REVISIONS			
NO.	DATE	BY	DESCRIPTION
A	07/24/2023	JCS	ISSUED FOR 60% REVIEW
B	9/8/2023	JCS	ISSUED FOR 90% REVIEW
0	10/17/2023	JCS	ISSUED FOR BID
C	1/X/2024	JCS	RE-ISSUED FOR REVIEW

OPERATING CENTER: BLOOMINGTON		DIVISION: VEDIN	
PROJECT#: 7604.5142	SCALE: 1" = 100'		
CITY / TOWNSHIP: BLOOMINGTON	COUNTY: MONROE	STATE: IN	

8" NS5153 NEEDMORE TO UNIONVILLE PRESSURE TEST & RETROFIT PIPELINE ALIGNMENT		
EnSiteUSA DWG NO. 1010	SHEET NO. SHEET 37	REV. C



DISCLAIMER: ENSITEUSA MAKES NO GUARANTEE THAT THIS SURVEY OR THESE MAPS CONTAINS COMPLETE OR CONCLUSIVE UNDERGROUND OR ABOVEGROUND UTILITY INFORMATION. THE CONTRACTOR IS RESPONSIBLE FOR VERIFYING THE LOCATION & PRESERVATION OF ALL UNDERGROUND AND ABOVEGROUND UTILITIES WHETHER OR NOT DEPICTED ON THESE DRAWINGS. THE CONTRACTOR IS TO CONTACT ALL OWNERS OF UNDERGROUND AND ABOVEGROUND UTILITIES PRIOR TO ANY EXCAVATION.

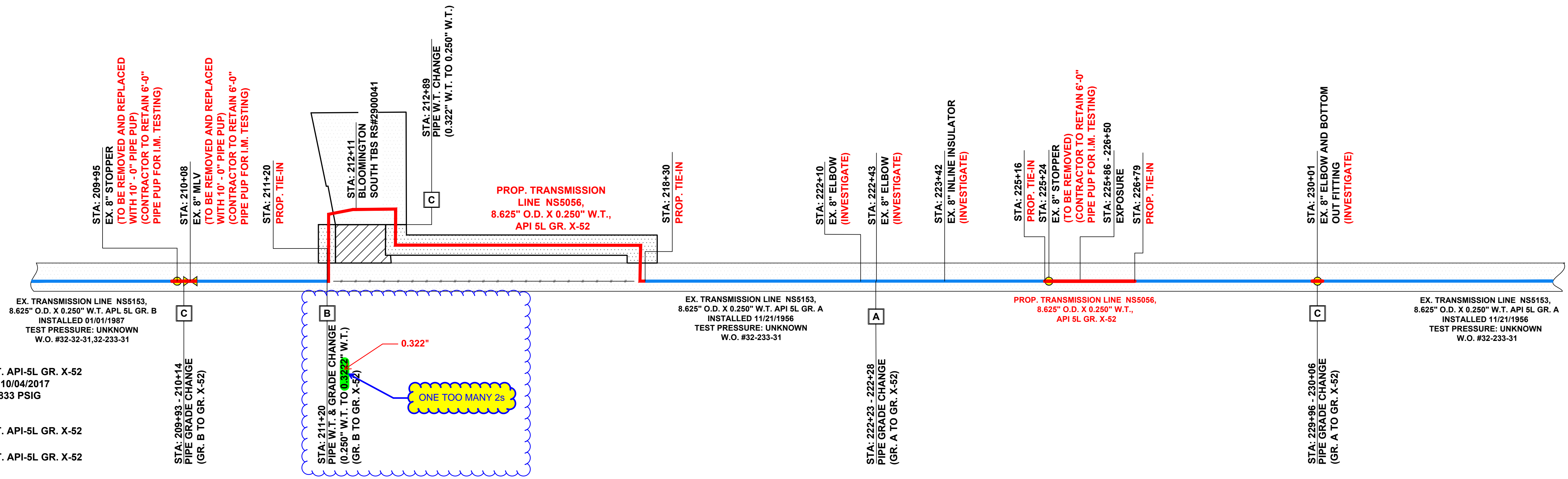
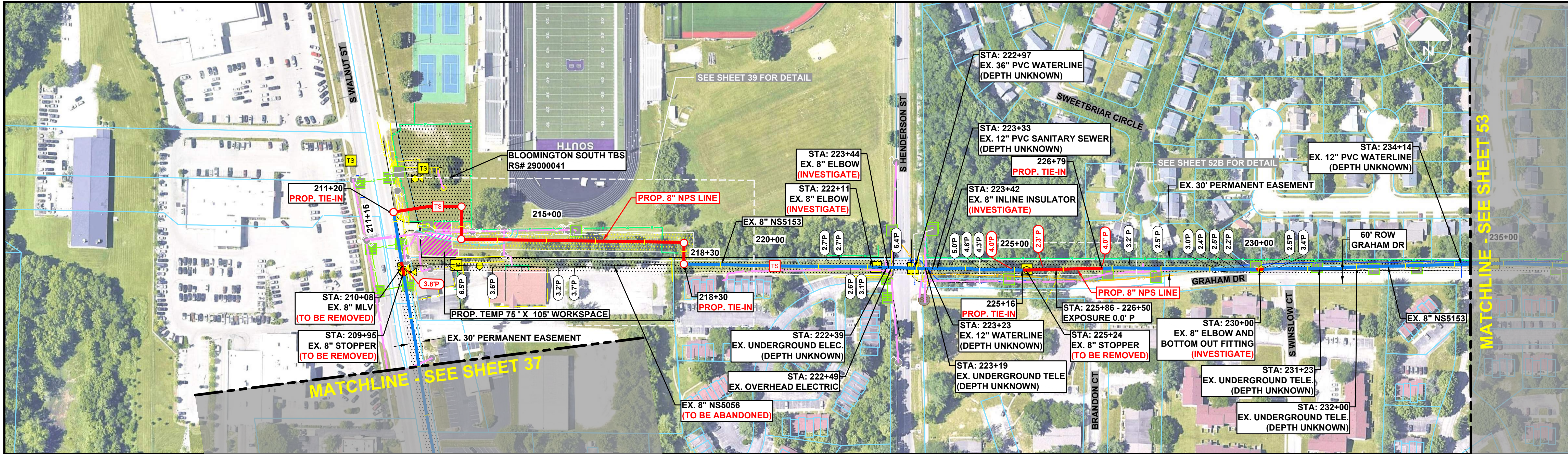

- A 8.625" X 0.250" W.T. API-5L GR. X-52
DATE INSTALLED: 10/04/2017
TEST PRESSURE: 833 PSIG
(WO #32-233-31)
- B 8.625" X 0.322" W.T. API-5L GR. X-52
- C 8.625" X 0.250" W.T. API-5L GR. X-52

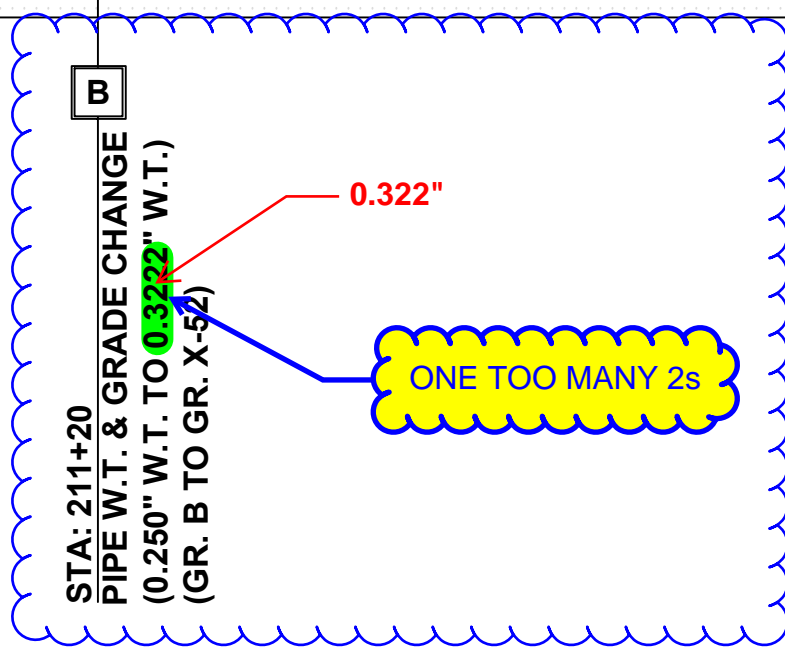

K:\7604-5142-00-NS5056\1-PL\7604-5142-1011102024-3-36-09 PM.Lst Saved 11/17/2023 9:36:20 AM by DWESLING; Last Plot: 1/10/2024 3:36:09 PM by JESSICA LAMB



**RE-ISSUED FOR REVIEW
NOT FOR CONSTRUCTION
1/1/2024**

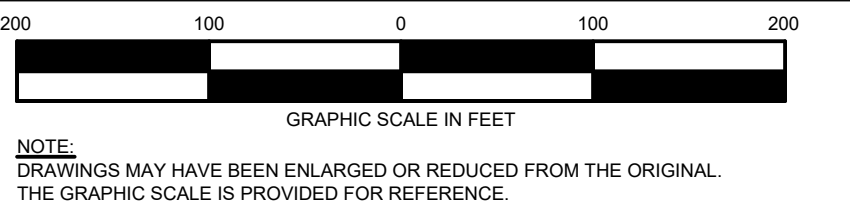

DISCLAIMER: ENSITEUSA MAKES NO GUARANTEE THAT THIS SURVEY OR THESE MAPS CONTAINS COMPLETE OR CONCLUSIVE UNDERGROUND OR ABOVEGROUND UTILITY INFORMATION. THE CONTRACTOR IS RESPONSIBLE FOR VERIFYING THE LOCATION & PRESERVATION OF ALL UNDERGROUND AND ABOVEGROUND UTILITIES WHETHER OR NOT DEPICTED ON THESE DRAWINGS. THE CONTRACTOR IS TO CONTACT ALL OWNERS OF UNDERGROUND AND ABOVEGROUND UTILITIES PRIOR TO ANY EXCAVATION.

REVISIONS			OPERATING CENTER:	DIVISION:
NO.	DATE	BY	BLOOMINGTON	VEDIN
C	9/8/2023	JCS	ISSUED FOR 90% REVIEW	
0	10/17/2023	JCS	ISSUED FOR BID	
0A	10/31/2023	JCS	RE-ISSUED FOR BID	
D	1/1/2024	JCS	RE-ISSUED FOR REVIEW	

PROJECT#: 7604.5142	SCALE: 1" = 100'	7" NS1513 NEEDMORE TO UNIONVILLE PRESSURE TEST & RETROFIT PIPELINE ALIGNMENT
CITY / TOWNSHIP: BLOOMINGTON	COUNTY: MONROE	STATE: IN
ENSiteUSA DWG NO. 1011	SHEET NO. 38	REV. D



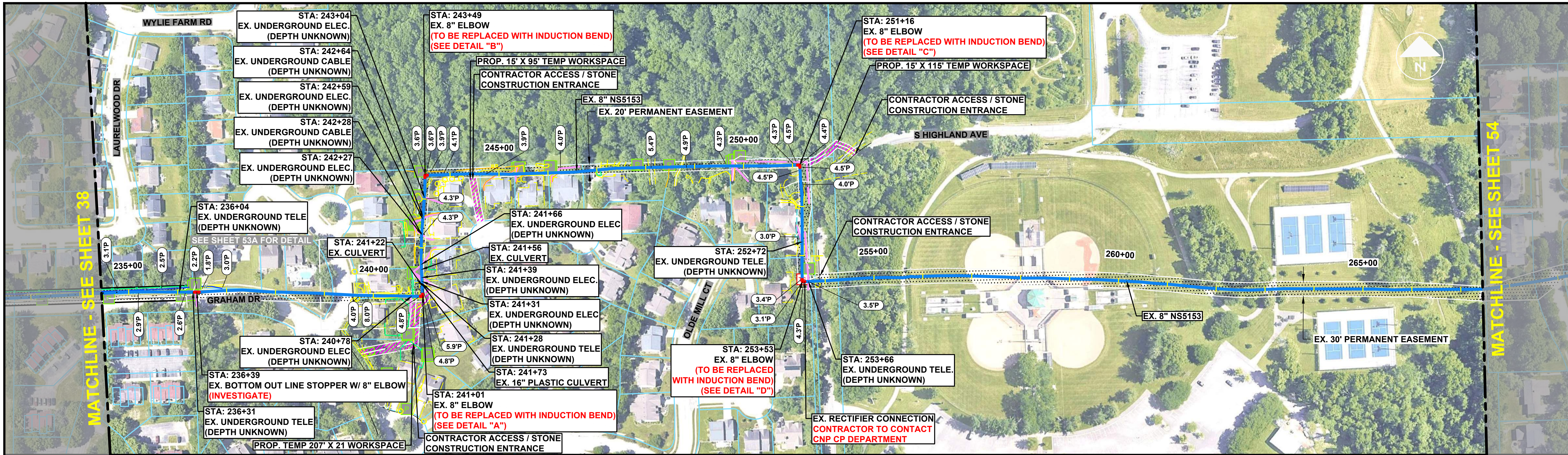

MATCHLINE - SEE SHEET 38

MATCHLINE - SEE SHEET 54

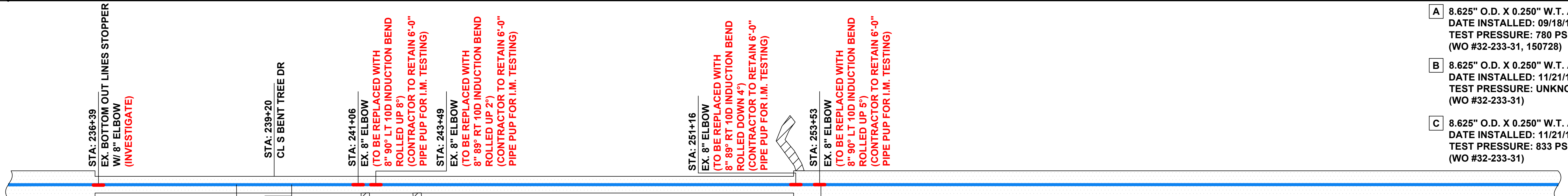

- A 8.625" O.D. X 0.250" W.T. API 5L GR. X-52
DATE INSTALLED: 09/18/1992
TEST PRESSURE: 780 PSIG
(WO #32-233-31, 150728)
- B 8.625" O.D. X 0.250" W.T. API 5L GR. A
DATE INSTALLED: 11/21/1956
TEST PRESSURE: UNKNOWN
(WO #32-233-31)
- C 8.625" O.D. X 0.250" W.T. API 5L GR. A
DATE INSTALLED: 11/21/1956
TEST PRESSURE: 833 PSIG
(WO #32-233-31)

EX. TRANSMISSION LINE NS5153, 8.625" O.D. X 0.250" W.T. APL 5L GR. A INSTALLED 11/21/1956 TEST PRESSURE: UNKNOWN W.O. #32-233-31

EX. TRANSMISSION LINE NS5153, 8.625" O.D. X 0.188" W.T. API 5L GR. X-42 INSTALLED 09/07/1993 TEST PRESSURE: 630 PSIG W.O. #150728, 32-233-31

EX. TRANSMISSION LINE NS5153, 8.625" O.D. X 0.250" W.T. API 5L GR. A INSTALLED 11/21/1956 TEST PRESSURE: 833 PSIG W.O. #32-233-31

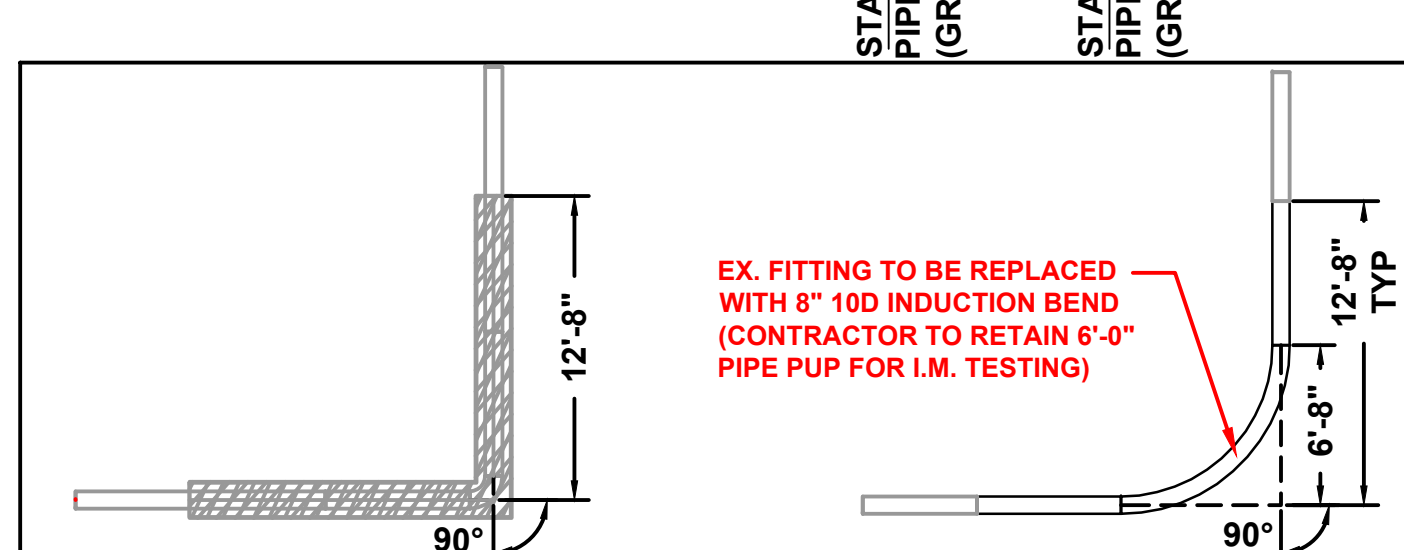

DETAIL A
SCALE: 1" = 8'

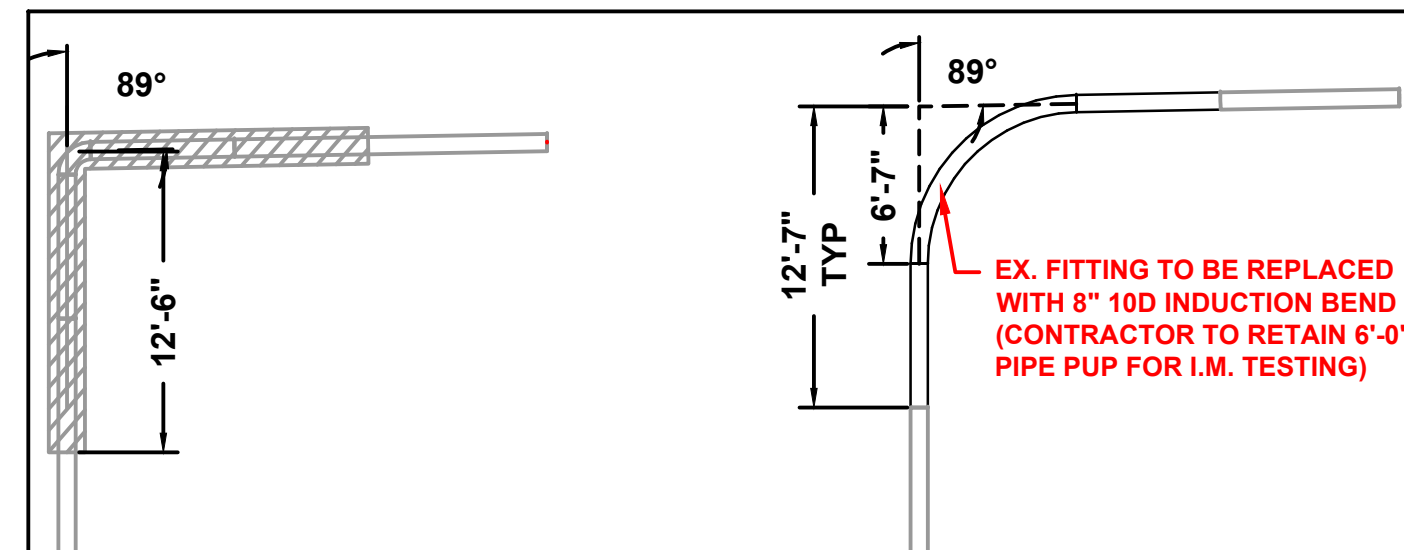

DETAIL B
SCALE: 1" = 8'

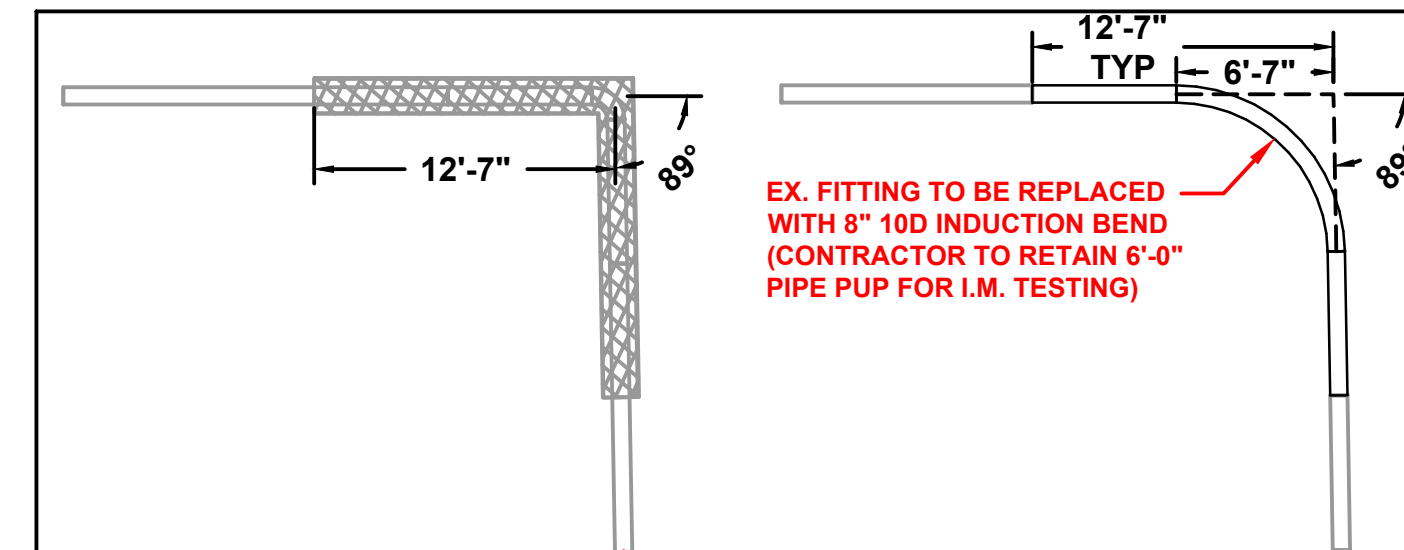

DETAIL C
SCALE: 1" = 8'

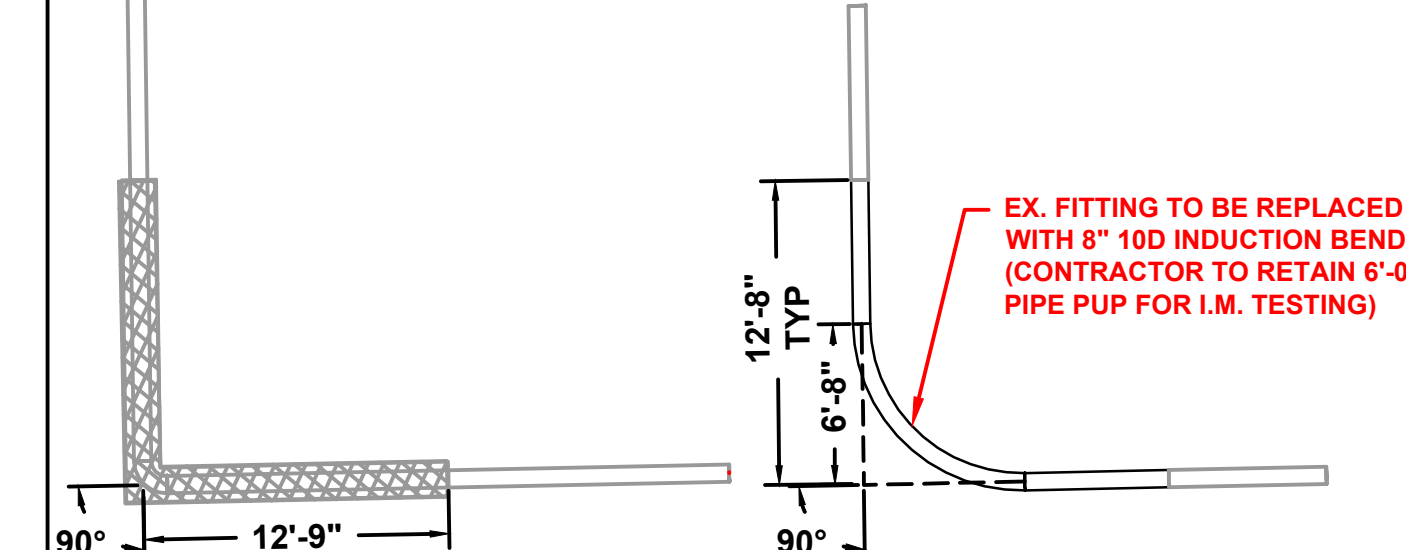

DETAIL D
SCALE: 1" = 8'



RE-ISSUED FOR REVIEW
NOT FOR CONSTRUCTION
1/1X/2024

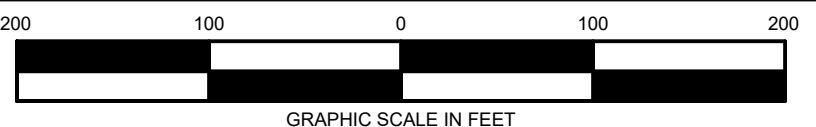

NOTE: DRAWINGS MAY HAVE BEEN ENLARGED OR REDUCED FROM THE ORIGINAL. THE GRAPHIC SCALE IS PROVIDED FOR REFERENCE.

REVISIONS			
NO.	DATE	BY	DESCRIPTION
C	9/8/2023	JCS	ISSUED FOR 90% REVIEW
0	10/17/2023	JCS	ISSUED FOR BID
0A	10/31/2023	JCS	RE-ISSUED FOR BID
D	1/1X/2024	JCS	RE-ISSUED FOR REVIEW

OPERATING CENTER: BLOOMINGTON	DIVISION: VEDIN
PROJECT#: 7604.5142	SCALE: 1" = 100'
CITY / TOWNSHIP: BLOOMINGTON	COUNTY: MONROE
STATE: IN	

8" NS5153 NEEDMORE TO UNIONVILLE PRESSURE TEST & RETROFIT PIPELINE ALIGNMENT		
EnSiteUSA DWG NO. 1012	SHEET NO. 53	REV. D



K:\7604.5142_BM_NS50661-PLU17604.5142_101211022024_3.37.09.PKL Last Saved 11/17/2023 9:44:11 AM by DWESLING; Last Plt 1/10/2024 3:37:09 PM by JESSICA LAMB

DISCLAIMER: ENSITEUSA MAKES NO GUARANTEE THAT THIS SURVEY OR THESE MAPS CONTAINS COMPLETE OR CONCLUSIVE UNDERGROUND OR ABOVEGROUND UTILITY INFORMATION. THE CONTRACTOR IS RESPONSIBLE FOR VERIFYING THE LOCATION & PRESERVATION OF ALL UNDERGROUND AND ABOVEGROUND UTILITIES WHETHER OR NOT DEPICTED ON THESE DRAWINGS. THE CONTRACTOR IS TO CONTACT ALL OWNERS OF UNDERGROUND AND ABOVEGROUND UTILITIES PRIOR TO ANY EXCAVATION.

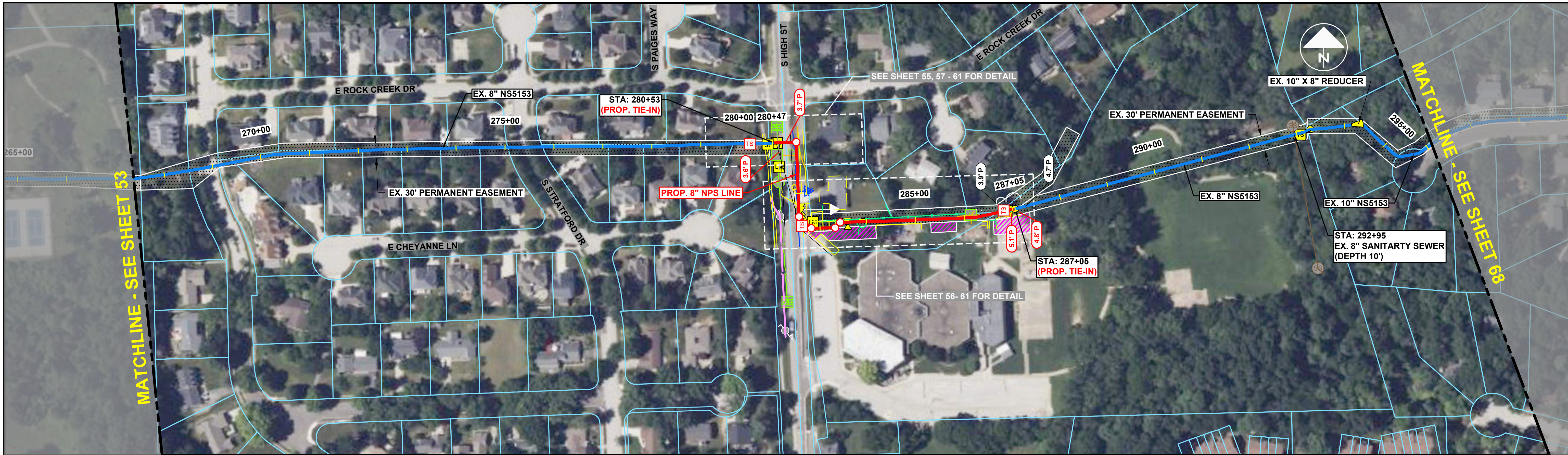

- A 8.625" O.D. X 0.250" W.T. API 5L GR. A
DATE INSTALLED: 11/21/1956
- B 10.750" O.D. X 0.188" W.T. API 5LGR. X-42
DATE INSTALLED: 11/28/1972
- C 8.625" O.D. X 0.250" W.T. API 5LGR. X-52
- D 8.625" O.D. X 0.250" W.T. API 5L GR. X-52
DATE INSTALLED: 08/02/2014
TEST PRESSURE: 1100 PSIG
(W.O.#145924020210)
- E 8.625" O.D. X 0.322" W.T. GR. X-52

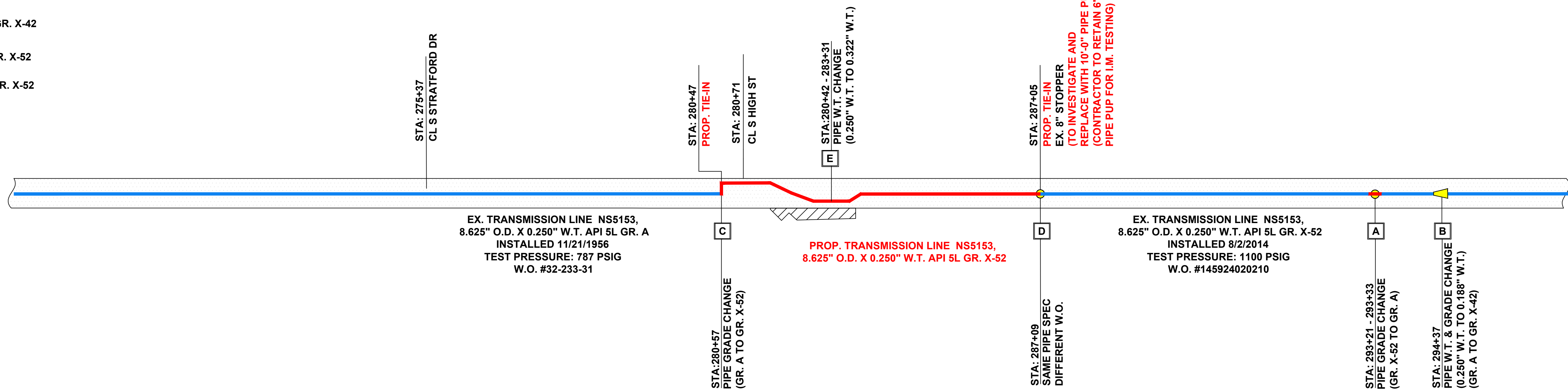

K:\7604-5142-00-NS50561-PL1\7604-5142-10-19-AM by DVEESLING: Last Pk: 1/10/2024 3:37:42 PM by JESSICA LAMB



**RE-ISSUED FOR REVIEW
NOT FOR CONSTRUCTION
1/1/2024**



NOTE:
DRAWINGS MAY HAVE BEEN ENLARGED OR REDUCED FROM THE ORIGINAL.
THE GRAPHIC SCALE IS PROVIDED FOR REFERENCE.

REVISIONS			
NO.	DATE	BY	DESCRIPTION
C	9/8/2023	JCS	ISSUED FOR 90% REVIEW
0	10/17/2023	JCS	ISSUED FOR BID
0A	10/31/2023	JCS	RE-ISSUED FOR BID
D	1/1/2024	JCS	RE-ISSUED FOR REVIEW

OPERATING CENTER: BLOOMINGTON	DIVISION: VEDIN
PROJECT#: 7604.5142	SCALE: 1" = 100'
CITY / TOWNSHIP: BLOOMINGTON	COUNTY: MONROE
STATE: IN	

8" NS5153 NEEDMORE TO UNIONVILLE PRESSURE TEST & RETROFIT PIPELINE ALIGNMENT		
EnSiteUSA DWG NO. 1013	SHEET NO. SHEET 54	REV. D



DISCLAIMER: ENSITEUSA MAKES NO GUARANTEE THAT THIS SURVEY OR THESE MAPS CONTAINS COMPLETE OR CONCLUSIVE UNDERGROUND OR ABOVEGROUND UTILITY INFORMATION. THE CONTRACTOR IS RESPONSIBLE FOR VERIFYING THE LOCATION & PRESERVATION OF ALL UNDERGROUND AND ABOVEGROUND UTILITIES WHETHER OR NOT DEPICTED ON THESE DRAWINGS. THE CONTRACTOR IS TO CONTACT ALL OWNERS OF UNDERGROUND AND ABOVEGROUND UTILITIES PRIOR TO ANY EXCAVATION.

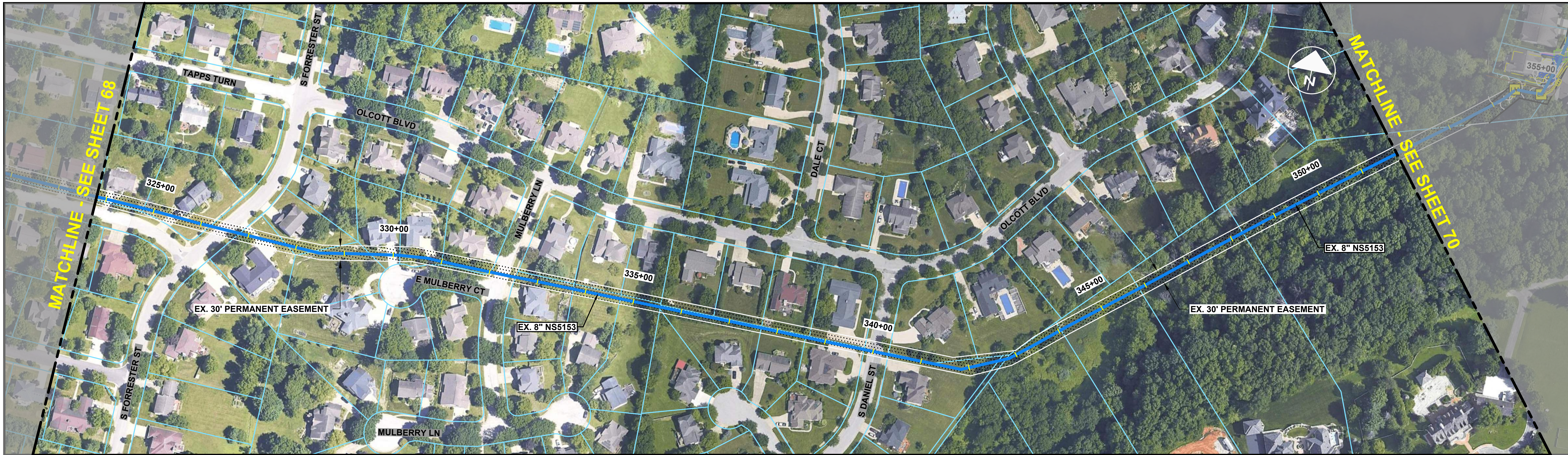

EX. TRANSMISSION LINE NS5153,
 8.625" O.D. X 0.250" W.T. API 5L GR. A
 INSTALLED 11/21/1956
 TEST PRESSURE: UNKNOWN
 W.O. #32-233-31

K:\7604-5142-00-NS50561-PL1\7604-5142-10-1110-2024-3-46-54 PM.Lst Saved 11/17/2023 9:13:56 AM by DWESLING; Last Plot: 1/10/2024 3:46:54 PM by JESSICA LAMB



RE-ISSUED FOR REVIEW
 NOT FOR CONSTRUCTION
 1/X/2024

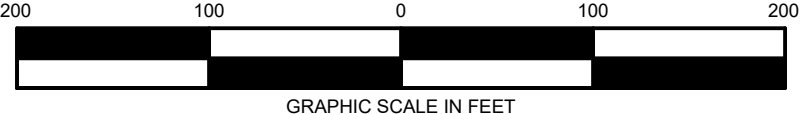

NOTE:
 DRAWINGS MAY HAVE BEEN ENLARGED OR REDUCED FROM THE ORIGINAL.
 THE GRAPHIC SCALE IS PROVIDED FOR REFERENCE.

REVISIONS			
NO.	DATE	BY	DESCRIPTION
B	9/8/2023	JCS	ISSUED FOR 90% REVIEW
0	10/17/2023	JCS	ISSUED FOR BID
0A	10/31/2023	JCS	RE-ISSUED FOR BID
C	1/X/2024	JCS	RE-ISSUED FOR REVIEW

OPERATING CENTER: BLOOMINGTON		DIVISION: VEDIN	
PROJECT#: 7604.5142	SCALE: 1" = 100'		
CITY / TOWNSHIP: BLOOMINGTON	COUNTY: MONROE	STATE: IN	

8" NS5153 NEEDMORE TO UNIONVILLE PRESSURE TEST & RETROFIT PIPELINE ALIGNMENT		
EnSiteUSA DWG NO. 1016	SHEET NO. SHEET 69	REV. C



DISCLAIMER: ENSITEUSA MAKES NO GUARANTEE THAT THIS SURVEY OR THESE MAPS CONTAINS COMPLETE OR CONCLUSIVE UNDERGROUND OR ABOVEGROUND UTILITY INFORMATION. THE CONTRACTOR IS RESPONSIBLE FOR VERIFYING THE LOCATION & PRESERVATION OF ALL UNDERGROUND AND ABOVEGROUND UTILITIES WHETHER OR NOT DEPICTED ON THESE DRAWINGS. THE CONTRACTOR IS TO CONTACT ALL OWNERS OF UNDERGROUND AND ABOVEGROUND UTILITIES PRIOR TO ANY EXCAVATION.

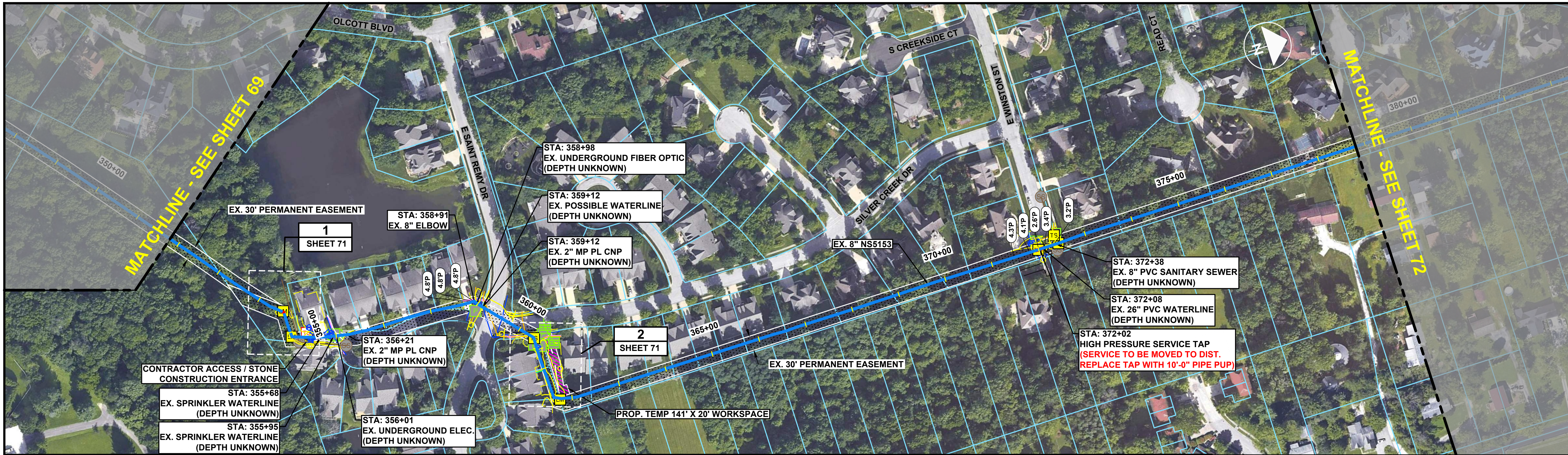

MATCHLINE - SEE SHEET 69

MATCHLINE - SEE SHEET 72

EX. 30' PERMANENT EASEMENT

1 SHEET 71

STA: 358+91
EX. 8" ELBOW

STA: 356+21
EX. 2" MP PL CNP
(DEPTH UNKNOWN)

STA: 355+68
EX. SPRINKLER WATERLINE
(DEPTH UNKNOWN)

STA: 355+95
EX. SPRINKLER WATERLINE
(DEPTH UNKNOWN)

CONTRACTOR ACCESS / STONE
CONSTRUCTION ENTRANCE

2 SHEET 71

STA: 358+98
EX. UNDERGROUND FIBER OPTIC
(DEPTH UNKNOWN)

STA: 359+12
EX. POSSIBLE WATERLINE
(DEPTH UNKNOWN)

STA: 359+12
EX. 2" MP PL CNP
(DEPTH UNKNOWN)

EX. 8" NS5153

EX. 30' PERMANENT EASEMENT

PROP. TEMP 141' X 20' WORKSPACE

STA: 356+01
EX. UNDERGROUND ELEC.
(DEPTH UNKNOWN)

STA: 372+38
EX. 8" PVC SANITARY SEWER
(DEPTH UNKNOWN)

STA: 372+08
EX. 26" PVC WATERLINE
(DEPTH UNKNOWN)

STA: 372+02
HIGH PRESSURE SERVICE TAP
(SERVICE TO BE MOVED TO DIST.
REPLACE TAP WITH 10'-0" PIPE PUP)



A 8.625" O.D. X 0.255" W.T. API 5L GR. A
DATE INSTALLED: 11/21/1956
TEST PRESSURE: UNKNOWN
(WO #32-233-31)

B 8.625" O.D. X 0.188" W.T. API 5L GR. X-42
DATE INSTALLED: 03/15/1993
TEST PRESSURE: 690 PSIG
(WO #150682)

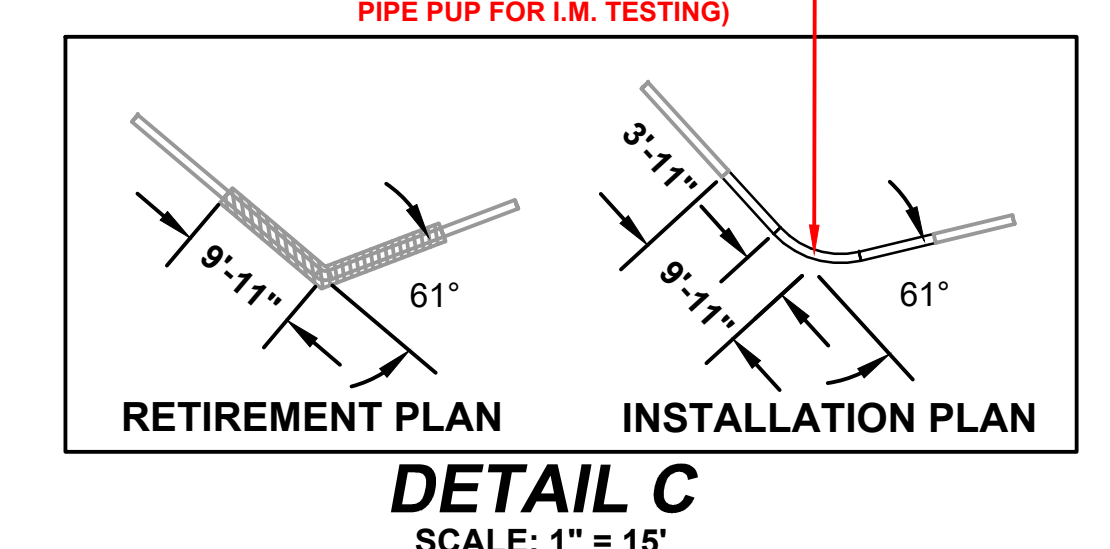
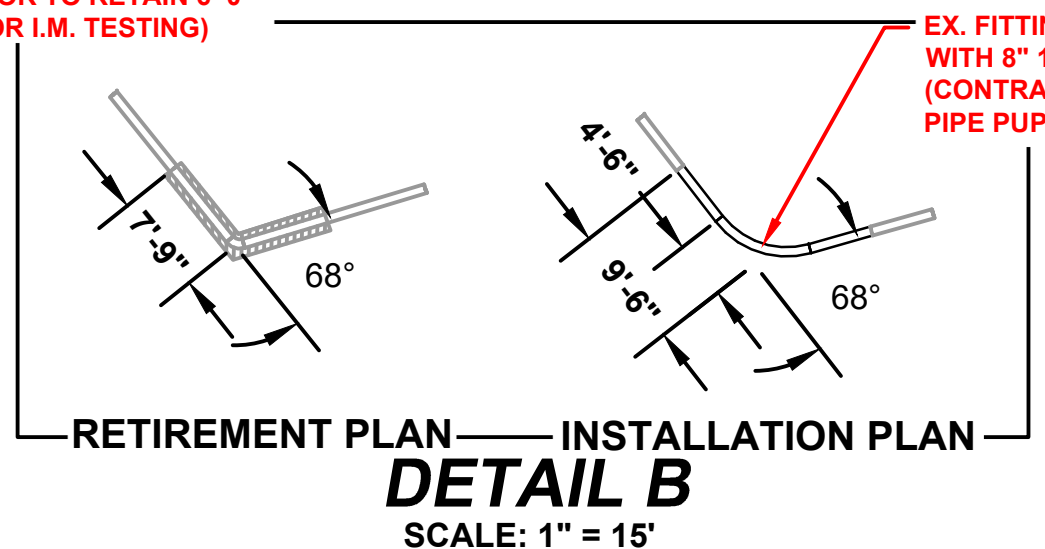
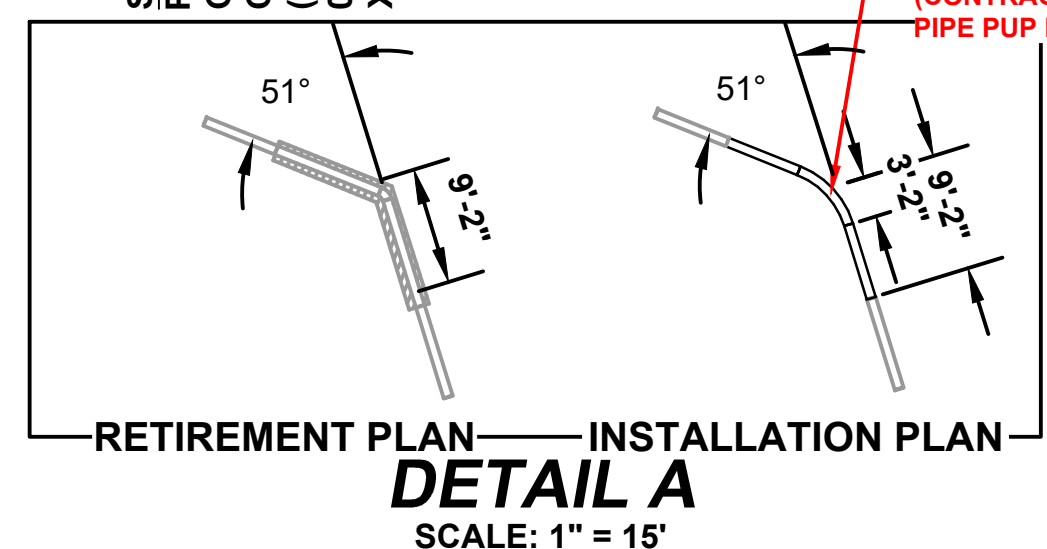

**RE-ISSUED FOR REVIEW
NOT FOR CONSTRUCTION
1/1/2024**

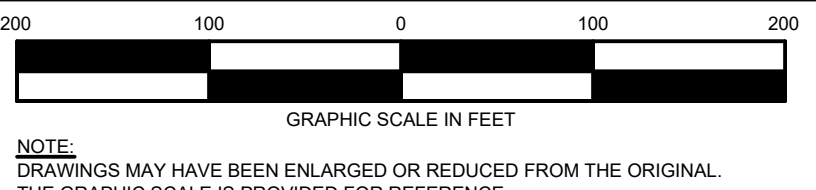

REVISIONS			
NO.	DATE	BY	DESCRIPTION
C	9/8/2023	JCS	ISSUED FOR 90% REVIEW
0	10/17/2023	JCS	ISSUED FOR BID
0A	10/31/2023	JCS	RE-ISSUED FOR BID
D	1/1/2024	JCS	RE-ISSUED FOR REVIEW

OPERATING CENTER: BLOOMINGTON	DIVISION: VEDIN
PROJECT#: 7604.5142	SCALE: 1" = 100'
CITY / TOWNSHIP: BLOOMINGTON	COUNTY: MONROE
STATE: IN	

8" NS5153 NEEDMORE TO UNIONVILLE PRESSURE TEST & RETROFIT PIPELINE ALIGNMENT		
EnSiteUSA DWG NO. 1017	SHEET NO. SHEET 70	REV. D



K:\7604.5142_BN_NS50661-PLU\7604.5142_101711022024_3:47:37 PM.dwg 11/17/2023 9:13:54 AM by DWESLING; Last Plot: 11/02/2024 3:47:37 PM by JESSICA LAMB

DISCLAIMER: ENSITEUSA MAKES NO GUARANTEE THAT THIS SURVEY OR THESE MAPS CONTAINS COMPLETE OR CONCLUSIVE UNDERGROUND OR ABOVEGROUND UTILITY INFORMATION. THE CONTRACTOR IS RESPONSIBLE FOR VERIFYING THE LOCATION & PRESERVATION OF ALL UNDERGROUND AND ABOVEGROUND UTILITIES WHETHER OR NOT DEPICTED ON THESE DRAWINGS. THE CONTRACTOR IS TO CONTACT ALL OWNERS OF UNDERGROUND AND ABOVEGROUND UTILITIES PRIOR TO ANY EXCAVATION.

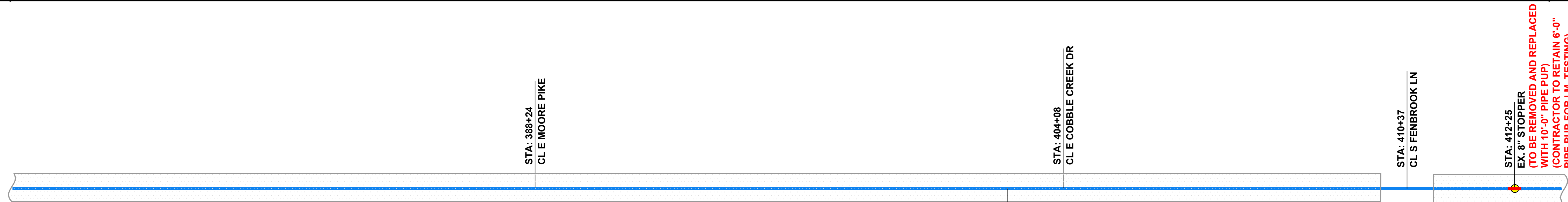
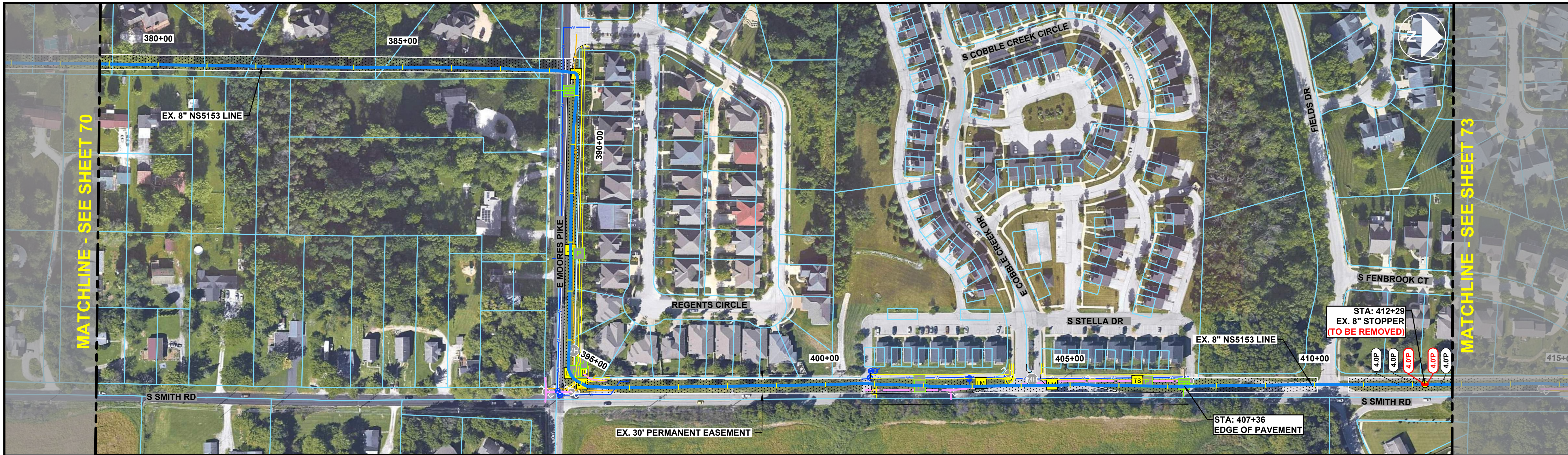

EX. TRANSMISSION LINE NS5153,
8.625" O.D. X 0.250" W.T. API 5L GR. A
INSTALLED 11/21/1956
TEST PRESSURE: UNKNOWN
W.O. #32-233-31

EX. TRANSMISSION LINE NS5153,
8.625" O.D. X 0.250" W.T. API 5L GR. A
INSTALLED 11/21/1956
TEST PRESSURE: UNKNOWN
W.O. #32-233-31

A 8.625" O.D. X 0.250" W.T. API 5L GR. X-42
DATE INSTALLED: 06/29/2004
TEST PRESSURE: 1200
(WO 32-233-31)

STA: 412+25
EX. 8" STOPPER
(TO BE REMOVED AND REPLACED
WITH 10'-0" PIPE PUP)
(CONTRACTOR TO RETAIN 6'-0"
PIPE PUP FOR I.M. TESTING)

K:\7604-5142-00-NS50561-PL1\7604-5142-10201102\2024-3-48-14 PM.dwg 11/17/2023 9:13:50 AM by DWESLINSJ: Last Plot: 1/10/2024 3:48:14 PM by JESSICA LAMB



**RE-ISSUED FOR REVIEW
NOT FOR CONSTRUCTION
1/1/2024**

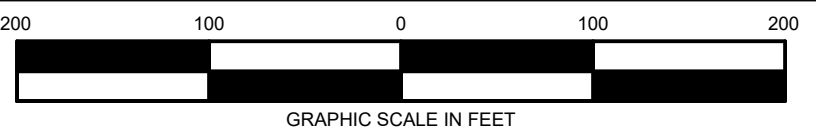

NOTE:
DRAWINGS MAY HAVE BEEN ENLARGED OR REDUCED FROM THE ORIGINAL.
THE GRAPHIC SCALE IS PROVIDED FOR REFERENCE.

REVISIONS			
NO.	DATE	BY	DESCRIPTION
C	9/8/2023	JCS	ISSUED FOR 90% REVIEW
0	10/17/2023	JCS	ISSUED FOR BID
0A	10/31/2023	JCS	RE-ISSUED FOR BID
D	1/1/2024	JCS	RE-ISSUED FOR REVIEW

OPERATING CENTER: BLOOMINGTON		DIVISION: VEDIN	
PROJECT#: 7604.5142	SCALE: 1" = 100'		
CITY / TOWNSHIP: BLOOMINGTON	COUNTY: MONROE	STATE: IN	

8" NS5153 NEEDMORE TO UNIONVILLE PRESSURE TEST & RETROFIT PIPELINE ALIGNMENT		
EnSiteUSA DWG NO. 1020	SHEET NO. SHEET 72	REV. D



DISCLAIMER: ENSITEUSA MAKES NO GUARANTEE THAT THIS SURVEY OR THESE MAPS CONTAINS COMPLETE OR CONCLUSIVE UNDERGROUND OR ABOVEGROUND UTILITY INFORMATION. THE CONTRACTOR IS RESPONSIBLE FOR VERIFYING THE LOCATION & PRESERVATION OF ALL UNDERGROUND AND ABOVEGROUND UTILITIES WHETHER OR NOT DEPICTED ON THESE DRAWINGS. THE CONTRACTOR IS TO CONTACT ALL OWNERS OF UNDERGROUND AND ABOVEGROUND UTILITIES PRIOR TO ANY EXCAVATION.

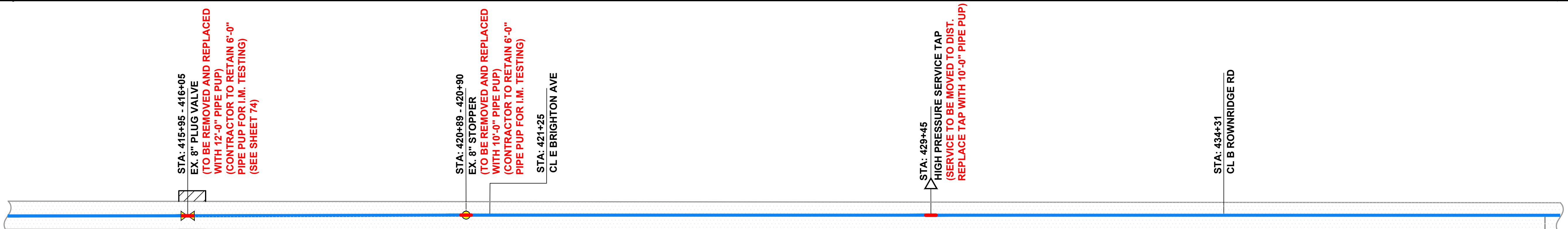
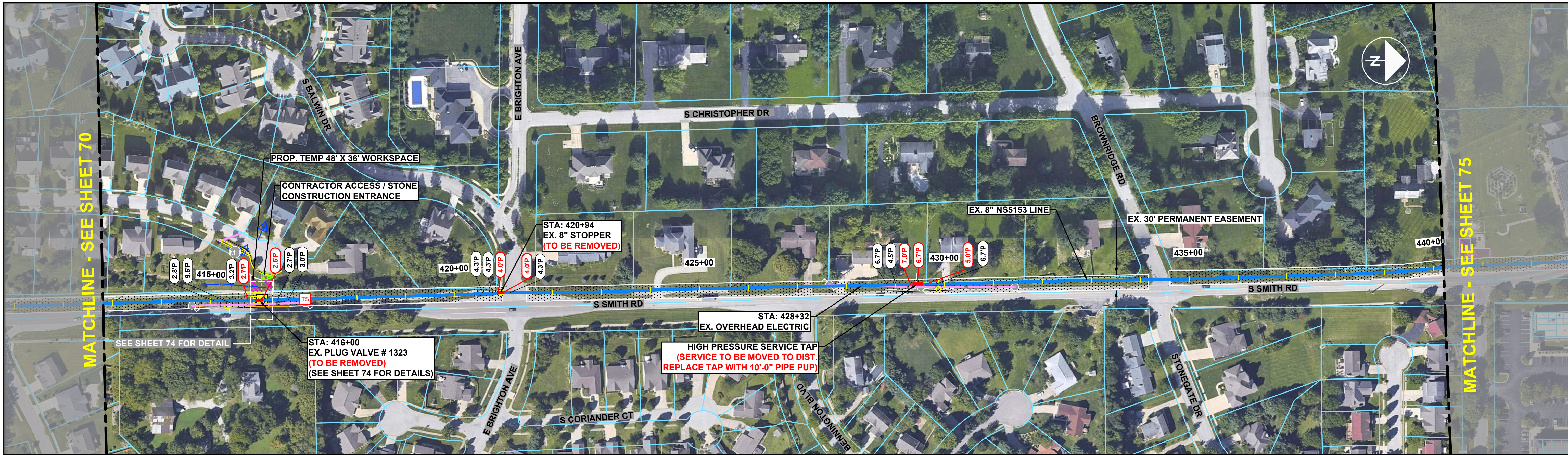

EX. TRANSMISSION LINE NS5153,
 8.625" O.D. X 0.250" W.T. API 5L GR. A
 INSTALLED 11/21/1996
 TEST PRESSURE: UNKNOWN
 W.O. #32-233-31

STA: 440+13
 PIPE W.T. & GRADE CHANGE
 (0.250" W.T. TO 0.188" W.T.)
 (GR. A TO GR. X-42)

A 8.625" O.D. X 0.188" W.T. API 5L GR. X-42
 DATE INSTALLED: 01/01/1994
 TEST PRESSURE: 570 PSI
 (WO #32-233-31)

K:\7604-5142-00-NS50561-PLU\7604-5142-102311022024-9-13-49 AM by DWESLING; Last Plot: 1/10/2024 3:48:28 PM by JESSICA LAMB



**RE-ISSUED FOR REVIEW
 NOT FOR CONSTRUCTION
 1/1/2024**

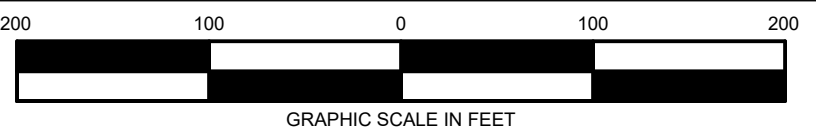

NOTE:
 DRAWINGS MAY HAVE BEEN ENLARGED OR REDUCED FROM THE ORIGINAL.
 THE GRAPHIC SCALE IS PROVIDED FOR REFERENCE.

REVISIONS			
NO.	DATE	BY	DESCRIPTION
C	9/8/2023	JG	ISSUED FOR 90% REVIEW
0	10/17/2023	JCS	ISSUED FOR BID
0A	10/31/2023	JCS	RE-ISSUED FOR BID
D	1/1/2024	JCS	RE-ISSUED FOR REVIEW

OPERATING CENTER: BLOOMINGTON	DIVISION: VEDIN
PROJECT#: 7604.5142	SCALE: 1" = 100'
CITY / TOWNSHIP: BLOOMINGTON	COUNTY: MONROE
STATE: IN	

8" NS5153 NEEDMORE TO UNIONVILLE PRESSURE TEST & RETROFIT PIPELINE ALIGNMENT		
EnSiteUSA DWG NO. 1023	SHEET NO. SHEET 73	REV. D



DISCLAIMER: ENSITEUSA MAKES NO GUARANTEE THAT THIS SURVEY OR THESE MAPS CONTAINS COMPLETE OR CONCLUSIVE UNDERGROUND OR ABOVEGROUND UTILITY INFORMATION. THE CONTRACTOR IS RESPONSIBLE FOR VERIFYING THE LOCATION & PRESERVATION OF ALL UNDERGROUND AND ABOVEGROUND UTILITIES WHETHER OR NOT DEPICTED ON THESE DRAWINGS. THE CONTRACTOR IS TO CONTACT ALL OWNERS OF UNDERGROUND AND ABOVEGROUND UTILITIES PRIOR TO ANY EXCAVATION.

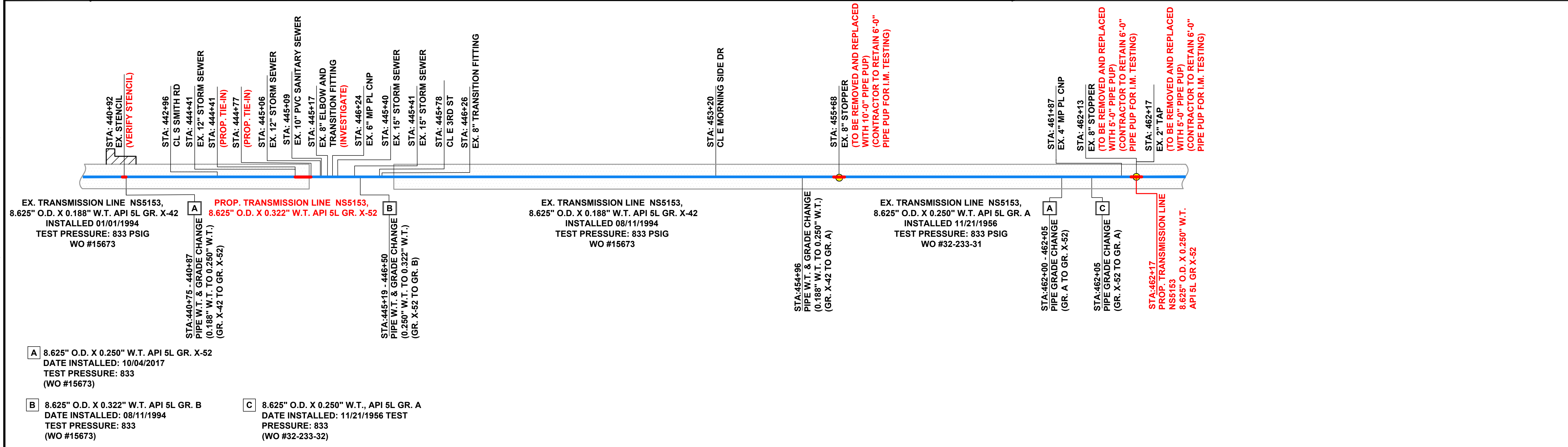
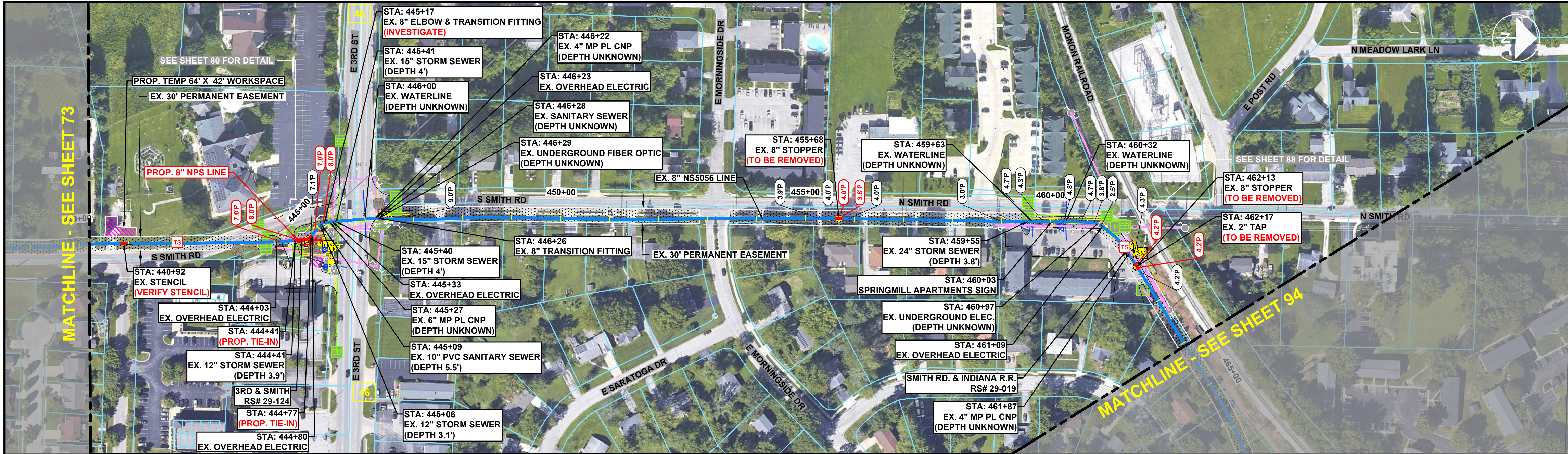

**RE-ISSUED FOR REVIEW
NOT FOR CONSTRUCTION
1/1/2024**

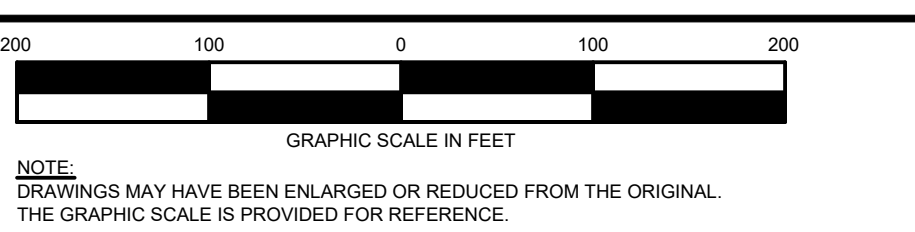

REVISIONS			
NO.	DATE	BY	DESCRIPTION
C	9/8/2023	JCS	ISSUED FOR 90% REVIEW
0	10/17/2023	JCS	ISSUED FOR BID
0A	10/31/2023	JCS	RE-ISSUED FOR BID
D	1/1/2024	JCS	RE-ISSUED FOR REVIEW

OPERATING CENTER: BLOOMINGTON		DIVISION: VEDIN	
PROJECT#: 7604.5142	SCALE: 1" = 100'		
CITY / TOWNSHIP: BLOOMINGTON	COUNTY: MONROE	STATE: IN	

8" NS5153 NEEDMORE TO UNIONVILLE PRESSURE TEST & RETROFIT PIPELINE ALIGNMENT			
EnSiteUSA DWG NO. 1022	SHEET NO. 75	REV. D	



DISCLAIMER: ENSITEUSA MAKES NO GUARANTEE THAT THIS SURVEY OR THESE MAPS CONTAINS COMPLETE OR CONCLUSIVE UNDERGROUND OR ABOVEGROUND UTILITY INFORMATION. THE CONTRACTOR IS RESPONSIBLE FOR VERIFYING THE LOCATION & PRESERVATION OF ALL UNDERGROUND AND ABOVEGROUND UTILITIES WHETHER OR NOT DEPICTED ON THESE DRAWINGS. THE CONTRACTOR IS TO CONTACT ALL OWNERS OF UNDERGROUND AND ABOVEGROUND UTILITIES PRIOR TO ANY EXCAVATION.

K:\7604.5142_BN_NS5056\1-PL\7604.5142_1022\11022024_3.48.47 PM.dwg by JESSICA LAMB 1/1/2024 3:48:47 PM

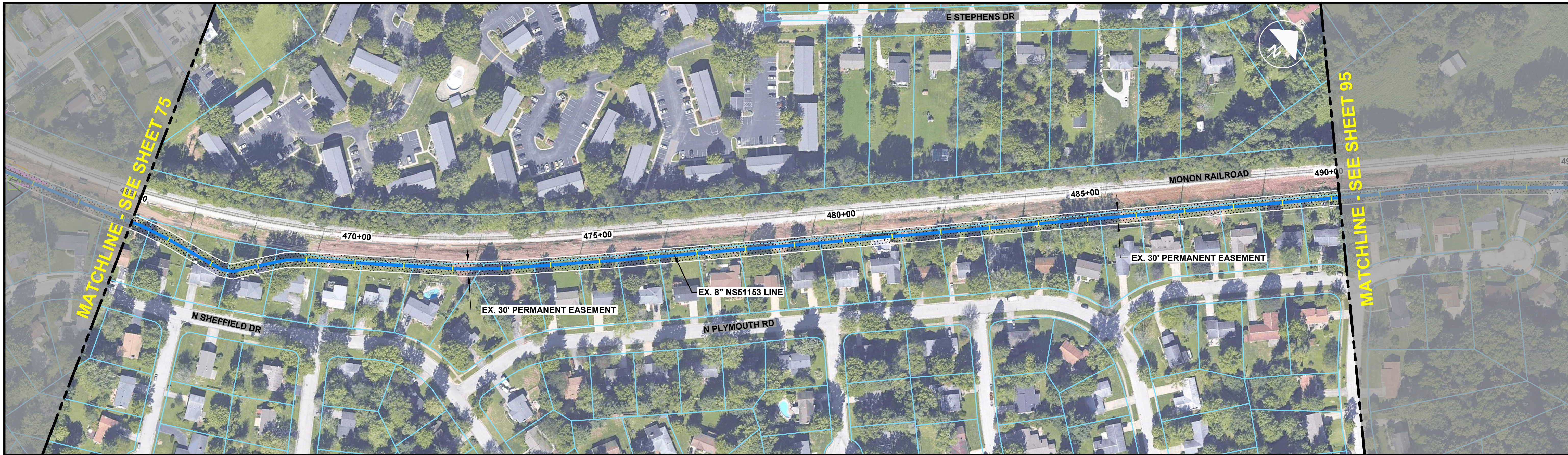

SCHEMATIC

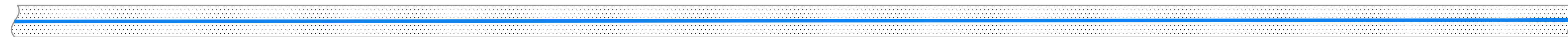

EX. TRANSMISSION LINE NS5153,
 8.625" O.D. X 0.250" W.T. API 5L GR. A
 (INSTALLED 11/21/1956)
 TEST PRESSURE: 833 PSIG
 W.O. #32-233-31

K:\7604-5142-00-NS50561-PLU\7604-5142-1024\11022024-3-49-02 PM.dwg by JESSICA LAMB 11/17/2023 9:45:53 AM by DWESLING: Last Plot: 1/10/2024 3:49:02 PM by JESSICA LAMB



**RE-ISSUED FOR REVIEW
 NOT FOR CONSTRUCTION
 1/X/2024**



NOTE:
 DRAWINGS MAY HAVE BEEN ENLARGED OR REDUCED FROM THE ORIGINAL.
 THE GRAPHIC SCALE IS PROVIDED FOR REFERENCE.

REVISIONS			
NO.	DATE	BY	DESCRIPTION
A	9/8/2023	AMN	ISSUED FOR 90% REVIEW
0	10/17/2023	JCS	ISSUED FOR BID
B	1/X/2024	JCS	RE-ISSUED FOR REVIEW
----	----	----	----

OPERATING CENTER: BLOOMINGTON		DIVISION: VEDIN	
PROJECT#: 7604-5142	SCALE: 1" = 100'		
CITY / TOWNSHIP: BLOOMINGTON	COUNTY: MONROE	STATE: IN	

8" NS5153 NEEDMORE TO UNIONVILLE PRESSURE TEST & RETROFIT PIPELINE ALIGNMENT			
EnSiteUSA DWG NO. 1024	SHEET NO. SHEET 94	REV. B	



DISCLAIMER: ENSITEUSA MAKES NO GUARANTEE THAT THIS SURVEY OR THESE MAPS CONTAINS COMPLETE OR CONCLUSIVE UNDERGROUND OR ABOVEGROUND UTILITY INFORMATION. THE CONTRACTOR IS RESPONSIBLE FOR VERIFYING THE LOCATION & PRESERVATION OF ALL UNDERGROUND AND ABOVEGROUND UTILITIES WHETHER OR NOT DEPICTED ON THESE DRAWINGS. THE CONTRACTOR IS TO CONTACT ALL OWNERS OF UNDERGROUND AND ABOVEGROUND UTILITIES PRIOR TO ANY EXCAVATION.

Bloomington MS4 to south of line,
 Monroe MS4 to north
 YL - SWPPP notes

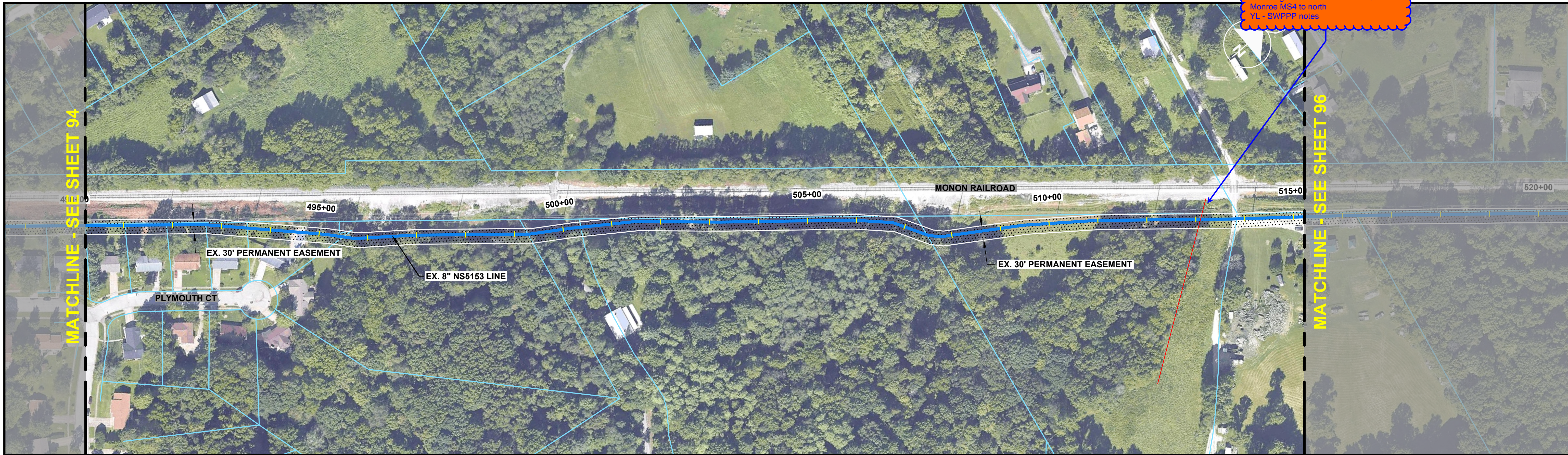

SCHEMATIC



**EX. TRANSMISSION LINE NS5153,
 8.625" O.D. X 0.250" W.T. API 5L GR. A
 (INSTALLED 11/21/1956)
 TEST PRESSURE: 833 PSIG
 W.O. #32-233-31**

K:\7604_5142_Bin_NS5095\1-PL\7604_5142_1025\10_2024_3:49:16 PM; Last Saved 11/17/2023 9:45:52 AM by DKEESLING; Last Plot 1/10/2024 3:49:16 PM by JESSICA_LAMB



**RE-ISSUED FOR REVIEW
 NOT FOR CONSTRUCTION
 1/1/2024**

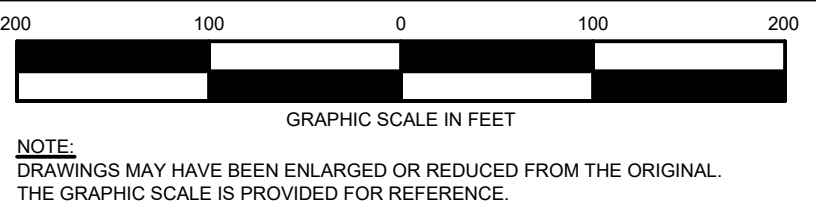

NOTE:
 DRAWINGS MAY HAVE BEEN ENLARGED OR REDUCED FROM THE ORIGINAL.
 THE GRAPHIC SCALE IS PROVIDED FOR REFERENCE.

REVISIONS			
NO.	DATE	BY	DESCRIPTION
A	9/8/2023	AMN	ISSUED FOR 90% REVIEW
O	10/17/2023	JCS	ISSUED FOR BID
B	1/1/2024	JCS	RE-ISSUED FOR REVIEW
----	----	----	----

OPERATING CENTER: BLOOMINGTON		DIVISION: VEDIN	
PROJECT#: 7604.5142	SCALE: 1" = 100'		
CITY / TOWNSHIP: BLOOMINGTON	COUNTY: MONROE	STATE: IN	

8" NS5153 NEEDMORE TO UNIONVILLE PRESSURE TEST & RETROFIT PIPELINE ALIGNMENT		
EnSiteUSA DWG NO. 1025	SHEET NO. SHEET 95	REV. B



DISCLAIMER: ENSITEUSA MAKES NO GUARANTEE THAT THIS SURVEY OR THESE MAPS CONTAINS COMPLETE OR CONCLUSIVE UNDERGROUND OR ABOVEGROUND UTILITY INFORMATION. THE CONTRACTOR IS RESPONSIBLE FOR VERIFYING THE LOCATION & PRESERVATION OF ALL UNDERGROUND AND ABOVEGROUND UTILITIES WHETHER OR NOT DEPICTED ON THESE DRAWINGS. THE CONTRACTOR IS TO CONTACT ALL OWNERS OF UNDERGROUND AND ABOVEGROUND UTILITIES PRIOR TO ANY EXCAVATION.

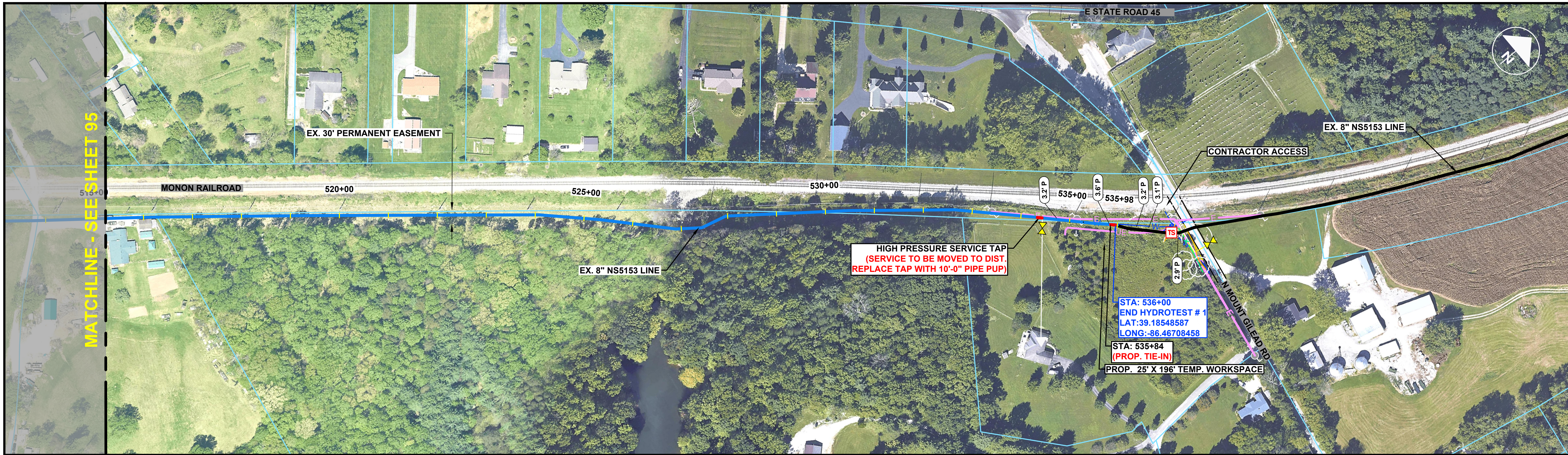

SCHEMATIC

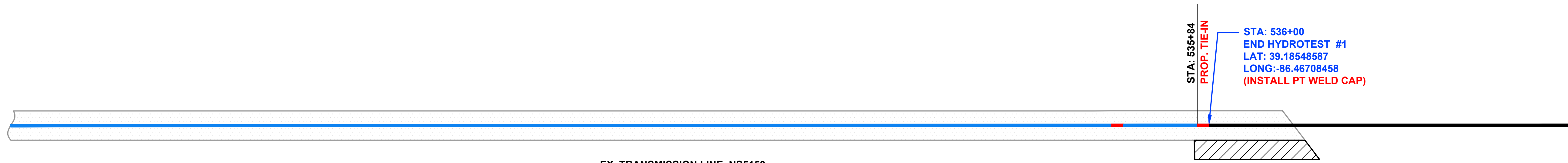

EX. TRANSMISSION LINE NS5153,
 8.625" O.D. X 0.250" W.T. API 5L GR. A
 (INSTALLED 11/21/1956)
 TEST PRESSURE: 833 PSIG
 W.O. #32-233-31



NOTE: DRAWINGS MAY HAVE BEEN ENLARGED OR REDUCED FROM THE ORIGINAL. THE GRAPHIC SCALE IS PROVIDED FOR REFERENCE.

REVISIONS			
NO.	DATE	BY	DESCRIPTION
A	9/8/2023	AMN	ISSUED FOR 90% REVIEW
0	10/17/2023	JCS	ISSUED FOR BID
0A	10/31/2023	JCS	RE-ISSUED FOR BID
B	1/1/2024	JCS	RE-ISSUED FOR REVIEW

OPERATING CENTER: BLOOMINGTON		DIVISION: VEDIN	
PROJECT#: 7604.5142	SCALE: 1" = 100'		
CITY / TOWNSHIP: BLOOMINGTON	COUNTY: MONROE	STATE: IN	

8" NS5153 NEEDMORE TO UNIONVILLE PRESSURE TEST & RETROFIT PIPELINE ALIGNMENT			
EnSiteUSA DWG NO. 1026	SHEET NO. SHEET 96	REV. B	



**RE-ISSUED FOR REVIEW
 NOT FOR CONSTRUCTION
 1/1/2024**



K:\7604.5142_Bin_NS5095\1-PL\7604.5142.10261/10/2024 3:49:32 PM; Last Saved 11/17/2023 9:45:50 AM by DKEESLING; Last Plot 1/10/2024 3:49:32 PM by JESSICA LAMB

DISCLAIMER: ENSITEUSA MAKES NO GUARANTEE THAT THIS SURVEY OR THESE MAPS CONTAINS COMPLETE OR CONCLUSIVE UNDERGROUND OR ABOVEGROUND UTILITY INFORMATION. THE CONTRACTOR IS RESPONSIBLE FOR VERIFYING THE LOCATION & PRESERVATION OF ALL UNDERGROUND AND ABOVEGROUND UTILITIES WHETHER OR NOT DEPICTED ON THESE DRAWINGS. THE CONTRACTOR IS TO CONTACT ALL OWNERS OF UNDERGROUND AND ABOVEGROUND UTILITIES PRIOR TO ANY EXCAVATION.

10IN & 8IN NS5059 DOLAN TO IU PRESSURE TEST & RETROFIT

HYDROTEST SECTIONS - LINE SUMMARY		
TEST SECTION	TEST LENGTH (LF)	FRAC TANKS REQ. (EA)
1	6,308	2

MAP LEGEND:

 PRESSURE TEST PIPELINE

 EXISTING PIPE

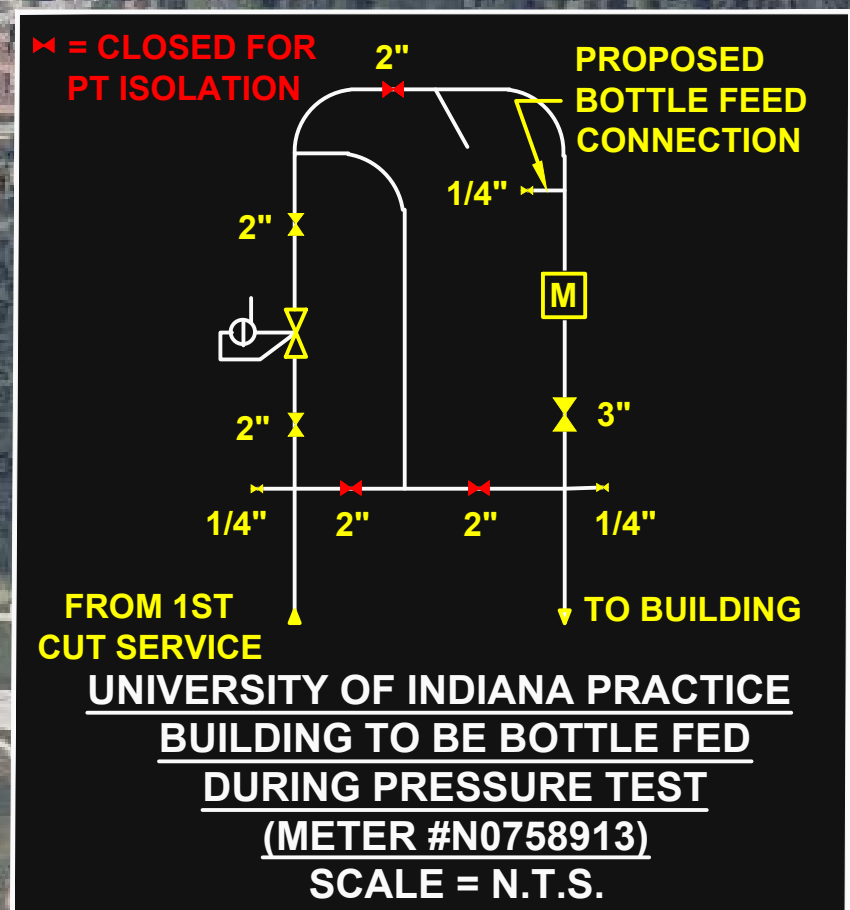
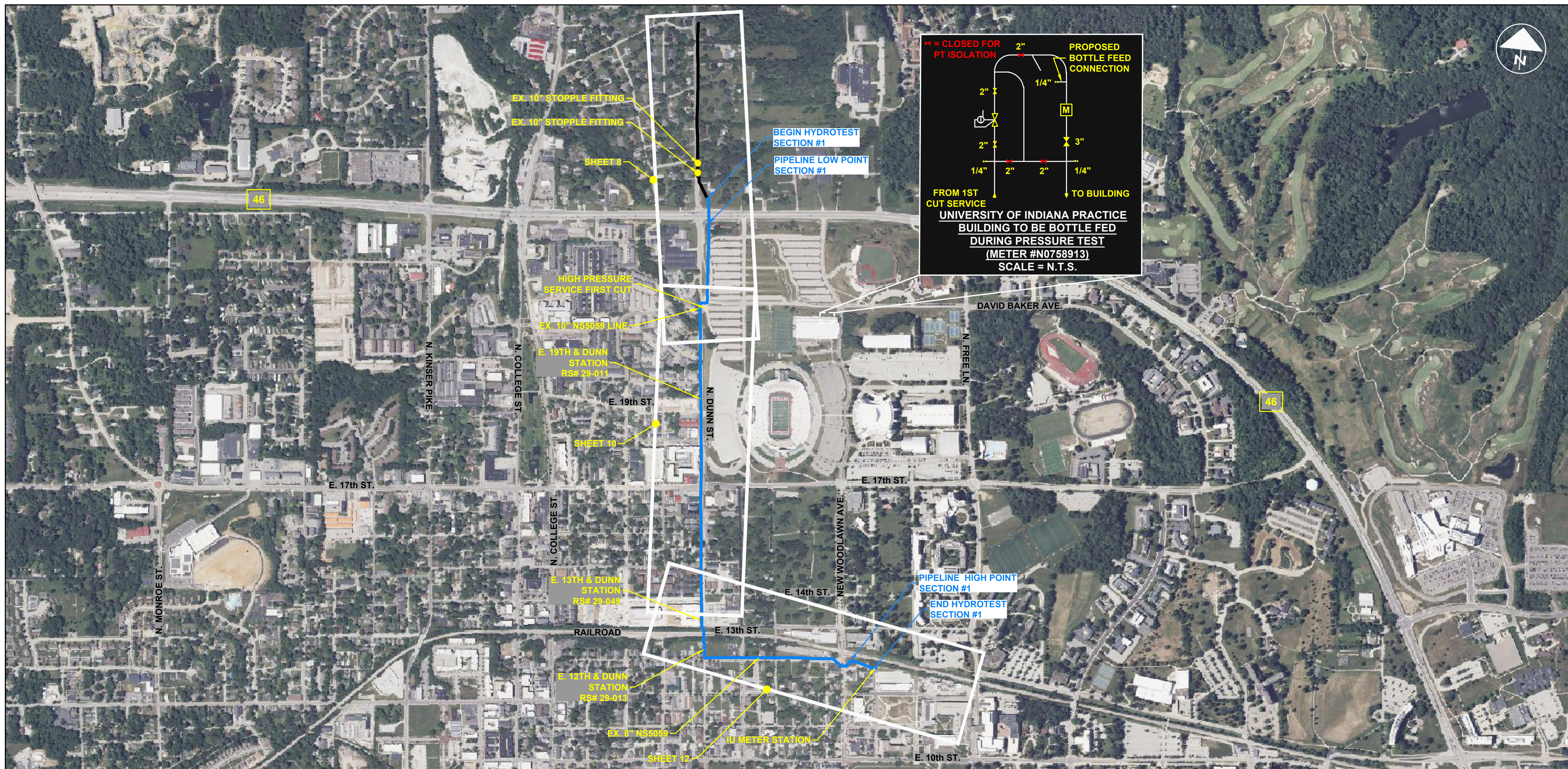

K:\7604_5050_8in_NS5059\Cover\7604_5050_0000\11022024_134226.PML, Last Saved: 12/22/2023 12:03:07 PM by TPOLEN, Last Plot: 1/10/2024 1:34:26 PM by CHAD SALLEE



**RE-ISSUED FOR REVIEW
NOT FOR CONSTRUCTION
1/1/2024**

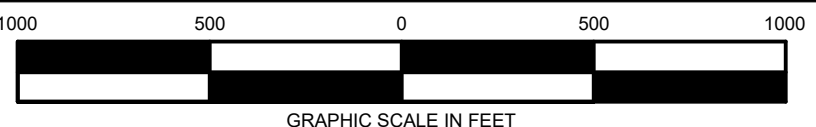

NOTE: DRAWINGS MAY HAVE BEEN ENLARGED OR REDUCED FROM THE ORIGINAL. THE GRAPHIC SCALE IS PROVIDED FOR REFERENCE.

REVISIONS		
NO.	DATE	DESCRIPTION
C	9/7/2023	JG ISSUED FOR 90% REVIEW
0	10/16/2023	DTK ISSUED FOR BID
0A	10/31/2023	DTK RE-ISSUED FOR BID
D	1/1/2024	DTK RE-ISSUED FOR REVIEW

OPERATING CENTER: BLOOMINGTON	DIVISION: VEDIN
PROJECT#: 7604.5050	SCALE: 1" = 500'
CITY / TOWNSHIP: BLOOMINGTON	COUNTY: MONROE
STATE: IN	

10IN & 8IN NS5059 DOLAN TO IU PRESSURE TEST & RETROFIT GENERAL COVER		
EnSiteUSA DWG NO. 0000	SHEET NO. SHEET 1	REV. D



DISCLAIMER: ENSITEUSA MAKES NO GUARANTEE THAT THIS SURVEY OR THESE MAPS CONTAINS COMPLETE OR CONCLUSIVE UNDERGROUND OR ABOVEGROUND UTILITY INFORMATION. THE CONTRACTOR IS RESPONSIBLE FOR VERIFYING THE LOCATION & PRESERVATION OF ALL UNDERGROUND AND ABOVEGROUND UTILITIES WHETHER OR NOT DEPICTED ON THESE DRAWINGS. THE CONTRACTOR IS TO CONTACT ALL OWNERS OF UNDERGROUND AND ABOVEGROUND UTILITIES PRIOR TO ANY EXCAVATION.

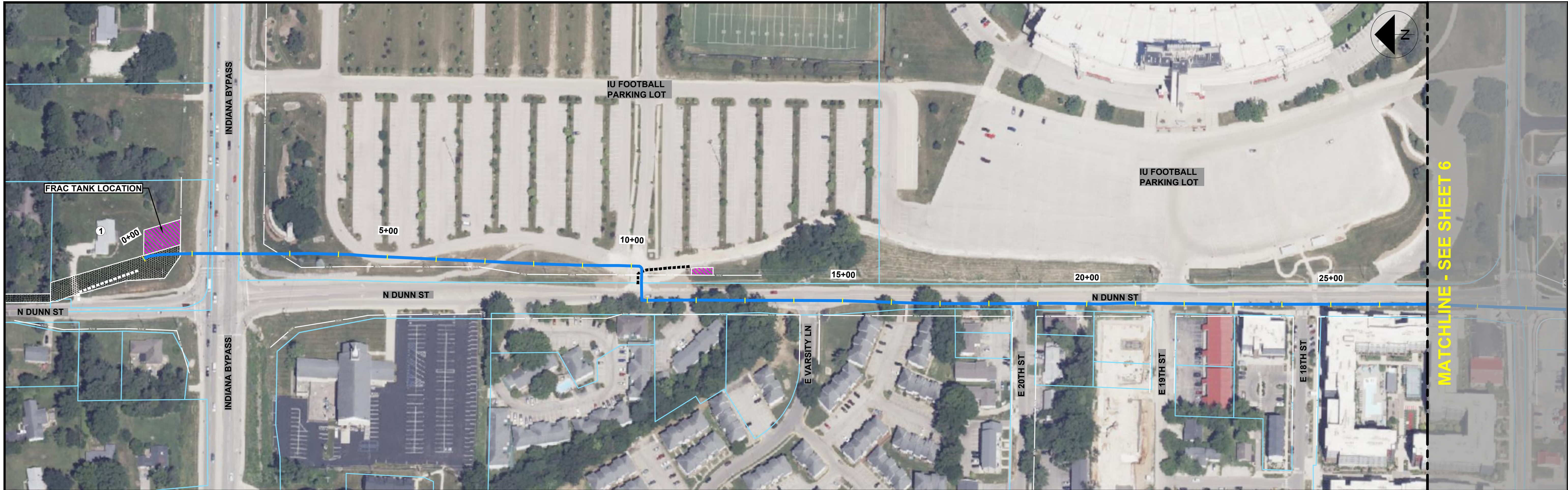

MATCHLINE - SEE SHEET 6

NUMBER	OWNER NAME	PARCEL ID	EXISTING EASEMENT	PROPOSED PERMANENT	PROPOSED TEMPORARY
1	TRUSTEES OF INDIANA UNIVERSITY	53-05-28-101-011.000-005	YES	NO	YES

K:\7604_5050_Bin\NS5059\Cover\7604_5050_0004\11/02/2024 1:34:48 PM, Last Saved 12/22/2023 11:16:20 AM by TPOLEN, Last Plot 11/02/2024 1:34:48 PM by CHAD SALLEE

	RE-ISSUED FOR REVIEW NOT FOR CONSTRUCTION 1/X/2024	Know what's below. Call 811 before you dig.	<p style="font-size: 8px;">NOTE: DRAWINGS MAY HAVE BEEN ENLARGED OR REDUCED FROM THE ORIGINAL. THE GRAPHIC SCALE IS PROVIDED FOR REFERENCE.</p>	REVISIONS		OPERATING CENTER: BLOOMINGTON	DIVISION: VEDIN	10IN & 8IN NS5059 DOLAN TO IU PRESSURE TEST & RETROFIT GENERAL PARCEL MAP																	
				<table border="1" style="width: 100%; border-collapse: collapse;"> <thead> <tr> <th>NO.</th> <th>DATE</th> <th>BY</th> <th>DESCRIPTION</th> </tr> </thead> <tbody> <tr> <td>A</td> <td>9/7/2023</td> <td>JCS</td> <td>ISSUED FOR 90% REVIEW</td> </tr> <tr> <td>0</td> <td>10/16/2023</td> <td>JCS</td> <td>ISSUED FOR BID</td> </tr> <tr> <td>0A</td> <td>10/31/2023</td> <td>JCS</td> <td>RE-ISSUED FOR BID</td> </tr> <tr> <td>B</td> <td>1/X/2024</td> <td>JCS</td> <td>RE-ISSUED FOR REVIEW</td> </tr> </tbody> </table>	NO.	DATE	BY	DESCRIPTION	A	9/7/2023		JCS	ISSUED FOR 90% REVIEW	0	10/16/2023	JCS	ISSUED FOR BID	0A	10/31/2023	JCS	RE-ISSUED FOR BID	B	1/X/2024	JCS	RE-ISSUED FOR REVIEW
NO.	DATE	BY	DESCRIPTION																						
A	9/7/2023	JCS	ISSUED FOR 90% REVIEW																						
0	10/16/2023	JCS	ISSUED FOR BID																						
0A	10/31/2023	JCS	RE-ISSUED FOR BID																						
B	1/X/2024	JCS	RE-ISSUED FOR REVIEW																						
DISCLAIMER: ENSITEUSA MAKES NO GUARANTEE THAT THIS SURVEY OR THESE MAPS CONTAINS COMPLETE OR CONCLUSIVE UNDERGROUND OR ABOVEGROUND UTILITY INFORMATION. THE CONTRACTOR IS RESPONSIBLE FOR VERIFYING THE LOCATION & PRESERVATION OF ALL UNDERGROUND AND ABOVEGROUND UTILITIES WHETHER OR NOT DEPICTED ON THESE DRAWINGS. THE CONTRACTOR IS TO CONTACT ALL OWNERS OF UNDERGROUND AND ABOVEGROUND UTILITIES PRIOR TO ANY EXCAVATION.																									

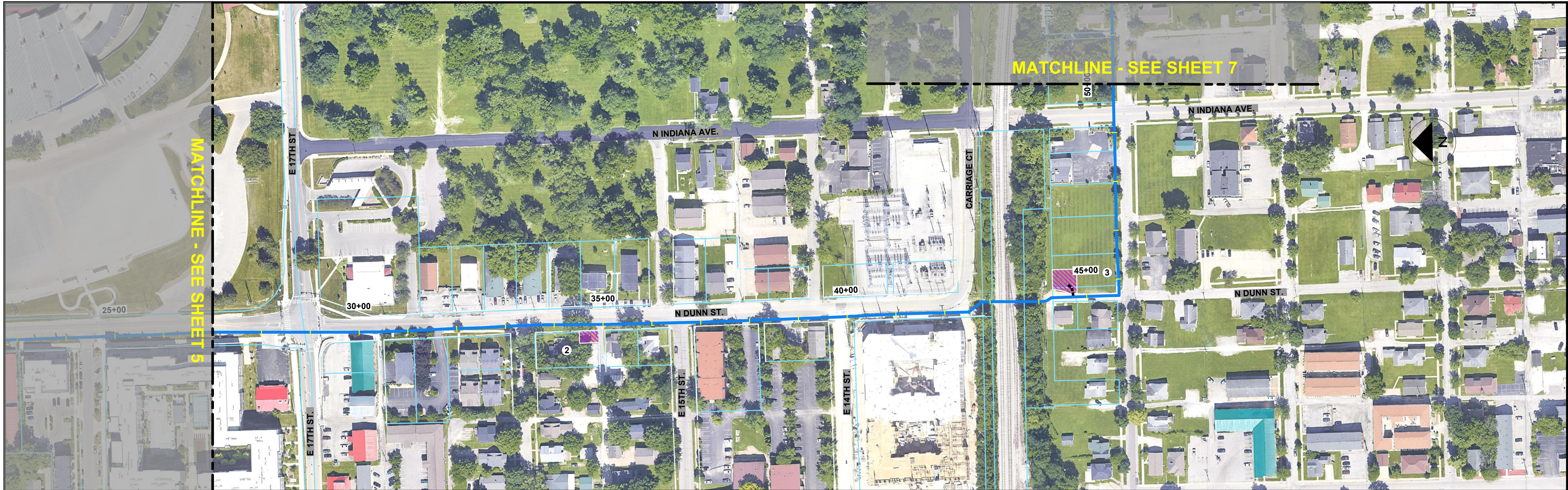

NUMBER	OWNER NAME	PARCEL ID	EXISTING EASEMENT	PROPOSED PERMANENT	PROPOSED TEMPORARY
2	FOX JERRY M AND JUSTIN	53-05-33-201-015.000-005	YES	NO	YES
3	STASNY AND HORN	53-05-33-105-138.000-005	NO	NO	YES

K:\7604_5050_Bin\NS5059\Cover\7604_5050_0005\1/10/2024 1:35:00 PM, Last Saved 1/22/2023 11:19:13 AM by TPOLEN, Last Plot 1/10/2024 1:35:00 PM by CHAD SALLEE



**RE-ISSUED FOR REVIEW
NOT FOR CONSTRUCTION
1/X/2024**

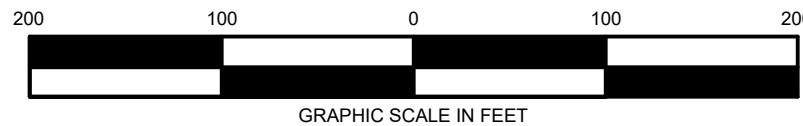

NOTE:
DRAWINGS MAY HAVE BEEN ENLARGED OR REDUCED FROM THE ORIGINAL.
THE GRAPHIC SCALE IS PROVIDED FOR REFERENCE.

REVISIONS			
NO.	DATE	BY	DESCRIPTION
A	9/7/2023	HCS	ISSUED FOR 90% REVIEW
0	10/16/2023	HCS	ISSUED FOR BID
B	1/X/2024	HCS	RE-ISSUED FOR REVIEW
----	----	----	----

OPERATING CENTER: BLOOMINGTON		DIVISION: VEDIN	
PROJECT#: 7604.5050	SCALE: 1" = 100'		
CITY / TOWNSHIP: BLOOMINGTON	COUNTY: MONROE	STATE: IN	

10IN & 8IN NS5059 DOLAN TO IU PRESSURE TEST & RETROFIT GENERAL PARCEL MAP			
EnSiteUSA DWG NO. 0005	SHEET NO. SHEET 6	REV. B	



DISCLAIMER: ENSITEUSA MAKES NO GUARANTEE THAT THIS SURVEY OR THESE MAPS CONTAINS COMPLETE OR CONCLUSIVE UNDERGROUND OR ABOVEGROUND UTILITY INFORMATION. THE CONTRACTOR IS RESPONSIBLE FOR VERIFYING THE LOCATION & PRESERVATION OF ALL UNDERGROUND AND ABOVEGROUND UTILITIES WHETHER OR NOT DEPICTED ON THESE DRAWINGS. THE CONTRACTOR IS TO CONTACT ALL OWNERS OF UNDERGROUND AND ABOVEGROUND UTILITIES PRIOR TO ANY EXCAVATION.

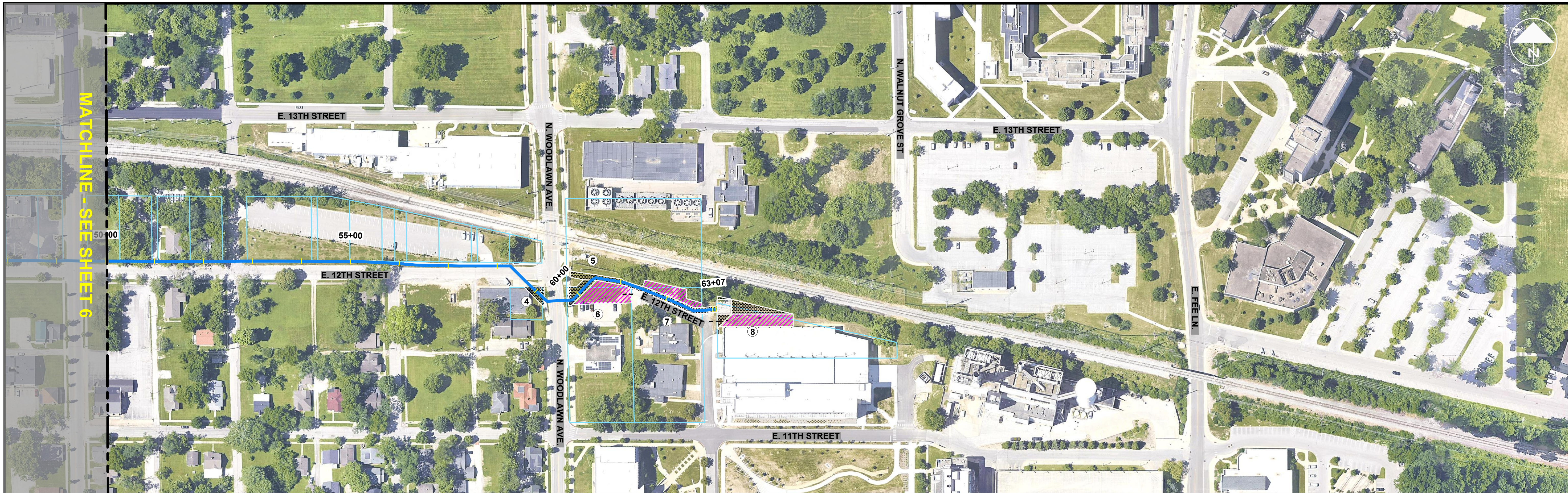

NUMBER	OWNER NAME	PARCEL ID	EXISTING EASEMENT	PROPOSED PERMANENT	PROPOSED TEMPORARY
4	TRUSTEES OF INDIANA UNIVERSITY	53-05-33-105-116.000-005	YES	NO	NO
5	TRUSTEES OF INDIANA UNIVERSITY	53-05-33-105-133.000-005	YES	NO	YES
6	CITY OF BLOOMINGTON	53-05-33-105-095.000-005	YES	NO	YES
7	TRUSTEES OF INDIANA UNIVERSITY	53-05-33-105-115.000-005	YES	NO	YES
8	TRUSTEES OF INDIANA UNIVERSITY	53-05-33-100-101.000-005	YES	NO	YES

K:\7604_5050_Bin\NS5059\Cover\7604_5050.dwg 1/10/2024 1:25:01 PM, Last Saved 12/19/2023 4:22:19 PM by DKESLINGS, Last Plot 1/10/2024 1:25:01 PM by CHAD SALLEE



**RE-ISSUED FOR REVIEW
NOT FOR CONSTRUCTION
1/X/2024**

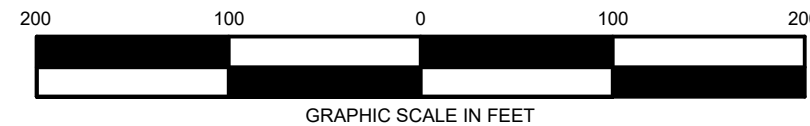

NOTE:
DRAWINGS MAY HAVE BEEN ENLARGED OR REDUCED FROM THE ORIGINAL.
THE GRAPHIC SCALE IS PROVIDED FOR REFERENCE.

REVISIONS			
NO.	DATE	BY	DESCRIPTION
A	9/7/2023	JCS	ISSUED FOR 90% REVIEW
0	10/16/2023	JCS	ISSUED FOR BID
B	1/X/2024	JCS	RE-ISSUED FOR REVIEW
----	----	----	----

OPERATING CENTER: BLOOMINGTON		DIVISION: VEDIN	
PROJECT#: 7604.5050	SCALE: 1" = 100'		
CITY / TOWNSHIP: BLOOMINGTON	COUNTY: MONROE	STATE: IN	

10IN & 8IN NS5059 DOLAN TO IU PRESSURE TEST & RETROFIT GENERAL PARCEL MAP			
EnSiteUSA DWG NO. 0006	SHEET NO. SHEET 7	REV. B	



DISCLAIMER: ENSITEUSA MAKES NO GUARANTEE THAT THIS SURVEY OR THESE MAPS CONTAINS COMPLETE OR CONCLUSIVE UNDERGROUND OR ABOVEGROUND UTILITY INFORMATION. THE CONTRACTOR IS RESPONSIBLE FOR VERIFYING THE LOCATION & PRESERVATION OF ALL UNDERGROUND AND ABOVEGROUND UTILITIES WHETHER OR NOT DEPICTED ON THESE DRAWINGS. THE CONTRACTOR IS TO CONTACT ALL OWNERS OF UNDERGROUND AND ABOVEGROUND UTILITIES PRIOR TO ANY EXCAVATION.

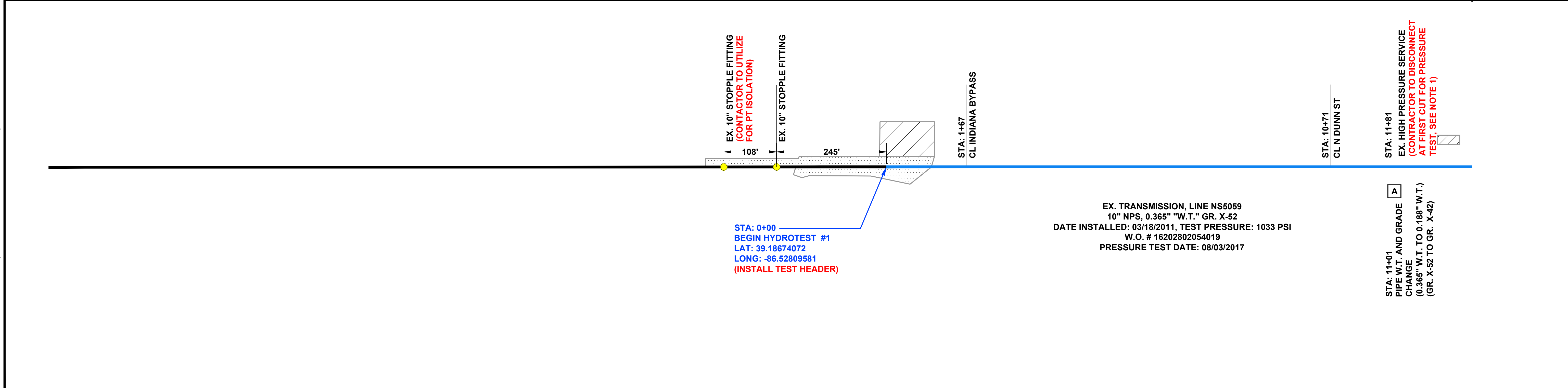
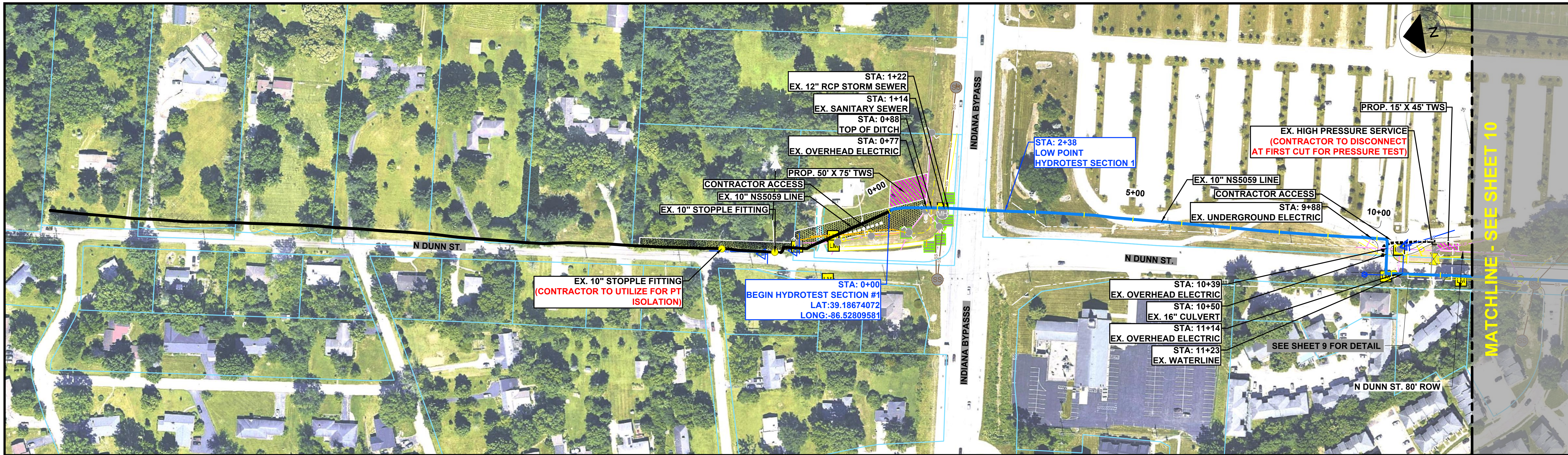

A 10" NPS, 0.188" "W.T." GR. X-42
 DATE INSTALLED: 9/10/1979
 TEST PRESSURE: 1033 PSI
 WO# 16202802054019
 PRESSURE TEST DATE: 08/03/2017

NOTE 1:
 INDIANA UNIVERSITY PRACTICE BUILDING TO
 BE BOTTLE-FED DURING PRESSURE TEST
 OUTAGE (SEE COVER SHEET FOR DETAIL)



**RE-ISSUED FOR REVIEW
 NOT FOR CONSTRUCTION
 1/X/2024**

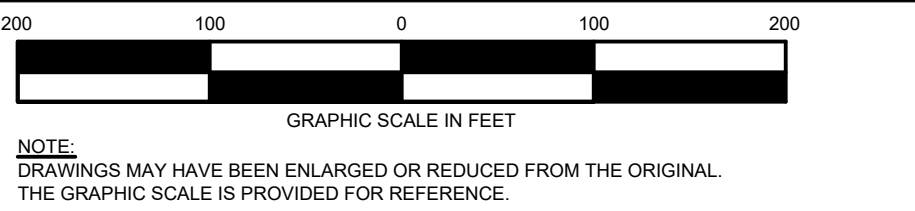

DISCLAIMER: ENSITEUSA MAKES NO GUARANTEE THAT THIS SURVEY OR THESE MAPS CONTAINS COMPLETE OR CONCLUSIVE UNDERGROUND OR ABOVEGROUND UTILITY INFORMATION. THE CONTRACTOR IS RESPONSIBLE FOR VERIFYING THE LOCATION & PRESERVATION OF ALL UNDERGROUND AND ABOVEGROUND UTILITIES WHETHER OR NOT DEPICTED ON THESE DRAWINGS. THE CONTRACTOR IS TO CONTACT ALL OWNERS OF UNDERGROUND AND ABOVEGROUND UTILITIES PRIOR TO ANY EXCAVATION.

REVISIONS			
NO.	DATE	BY	DESCRIPTION
C	9/7/2023	JG	ISSUED FOR 90% REVIEW
0	10/16/2023	JG	ISSUED FOR BID
0A	10/31/2023	JG	RE-ISSUED FOR BID
D	1/X/2024	JG	RE-ISSUED FOR REVIEW

OPERATING CENTER: BLOOMINGTON	DIVISION: VEDIN
PROJECT#: 7604.5050	SCALE: 1" = 100'
CITY / TOWNSHIP: BLOOMINGTON	COUNTY: MONROE
STATE: IN	

10IN & 8IN NS5059 DOLAN TO IU PRESSURE TEST & RETROFIT PIPELINE ALIGNMENT		
EnSiteUSA DWG NO. 1010	SHEET NO. SHEET 8	REV. D



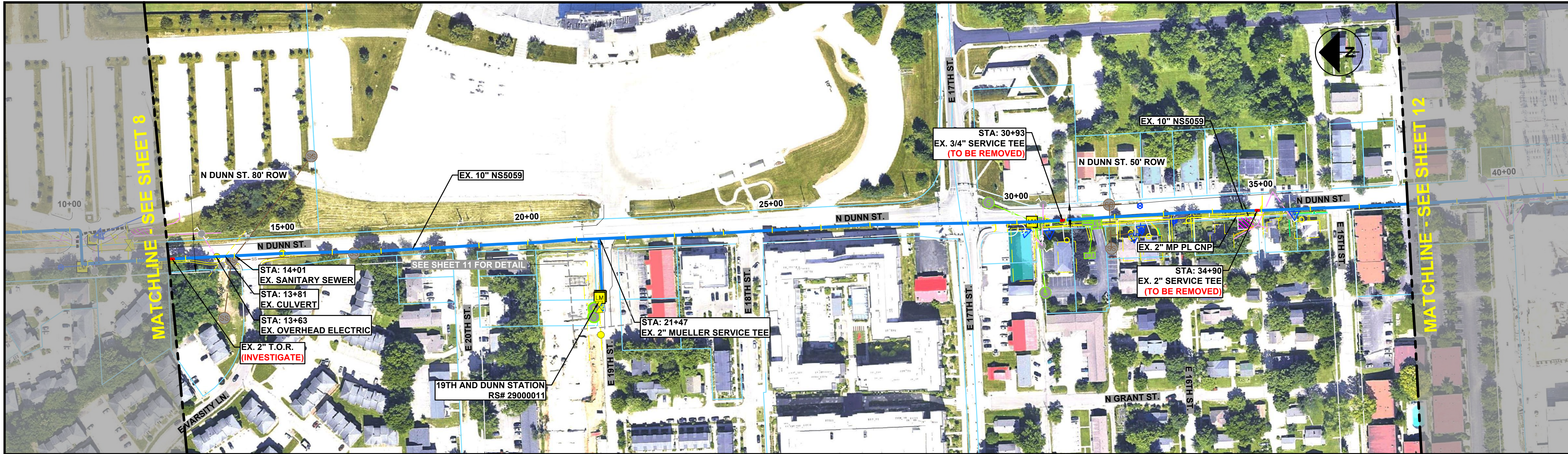

MATCHLINE - SEE SHEET 8

MATCHLINE - SEE SHEET 12



STA: 12+73 EX. 2" TOR (TO BE VERIFIED) (CONTRACTOR TO RETAIN 6'-0" PIPE RUP FOR IM INVESTIGATION IF BEING REMOVED)	STA: 14+31 CLE VARSITY LN.	STA: 18+67 CLE E 20TH ST	STA: 21+61 CLE E 19TH ST	STA: 24+45 CLE E 18TH ST	STA: 29+00 CLE E 17TH ST	STA: 30+93 EX. 3/4" SERVICE TEE (TO BE REMOVED) (CONTRACTOR TO RETAIN 6'-0" PIPE RUP FOR IM INVESTIGATION)	STA: 33+38 CLE E 16TH ST	STA: 34+90 EX. 2" SERVICE TEE (TO BE REMOVED) (CONTRACTOR TO RETAIN 6'-0" PIPE RUP FOR IM INVESTIGATION)	STA: 36+57 CLE E 15TH ST
--	-------------------------------	-----------------------------	-----------------------------	-----------------------------	-----------------------------	---	-----------------------------	---	-----------------------------

EX. TRANSMISSION, LINE NS5059
10" NPS, 0.188" W.T. GR. X-42
DATE INSTALLED: 09/10/1979, TEST PRESSURE 1033 PSI
W.O. #16202802054019
PRESSURE TEST DATE: 08/03/2017

STA: 21+47
PIPE SIZE, W.T., AND
GRADE CHANGE
(0.188" W.T. TO 0.156" W.T.)
(GR. X-42 TO GR. UNK.)
(SEE NOTE 1)

STA: 26+82 - 26+87
PIPE W.T. AND GRADE
CHANGE
(0.188" W.T. TO 0.250" W.T.)
(GR. X-42 TO GR. X-52)

STA: 26+87 - 27+94
PIPE W.T. AND GRADE
CHANGE
(0.250" W.T. TO 0.188" W.T.)
(GR. X-52 TO GR. X-42)

STA: 27+94 - 28+00
PIPE W.T. AND GRADE
CHANGE
(0.188" W.T. TO 0.250" W.T.)
(GR. X-42 TO GR. X-52)

EX. TRANSMISSION, LINE NS5059
10" NPS, 0.188" W.T. GR. X-42
DATE INSTALLED: 09/10/1979, TEST PRESSURE 1033 PSI
W.O. #16202802054019
PRESSURE TEST DATE: 08/03/2017

STA: 37+03 - 37+08
PIPE W.T. AND GRADE
CHANGE
(0.188" W.T. TO 0.250" W.T.)
(GR. X-42 TO GR. X-52)

STA: 37+08
PIPE W.T. AND GRADE
CHANGE
(0.250" W.T. TO 0.188" W.T.)
(GR. X-52 TO GR. X-42)

- A 10" NPS, 0.250" W.T., GR. X-52
DATE INSTALLED: 8/17/2017
TEST PRESSURE: 1033 PSI
WO# 16202802054019
PRESSURE TEST DATE: 08/03/2017
- B 10" NPS, 0.188" W.T., GR. X-42
DATE INSTALLED: 9/10/1979
TEST PRESSURE: 1033 PSI
WO# 16202802054019
PRESSURE TEST DATE: 08/03/2017
- C 4" NPS, 0.156" W.T., GR. UNK.
DATE INSTALLED: 10/11/1994
TEST PRESSURE: UNK.
WO# 150835

NOTE 1:
PRESSURE TEST CRITICAL MATERIAL IDENTIFIED
AS THE EXISTING 2" NPS STATION INLET VALVE
(ROCKWELL FIG 2045 1/2, ANSI 300)
STA: 21+47
ELEV: 763.28

K:\7604_5059_Bin\NS5059B1-PL17604_5059_101111\2024_1033_34_PNL_Last Saved_12/22/2023 11:44:55 AM by TPOLEN, Last Plot: 1/11/2024 1:03:34 PM by CHAD SALLEE



RE-ISSUED FOR REVIEW
NOT FOR CONSTRUCTION
1/1/2024

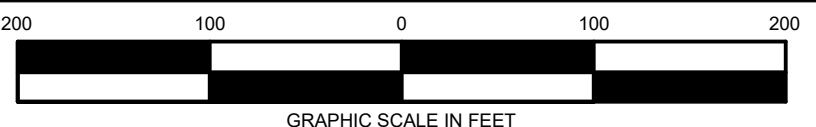

NOTE:
DRAWINGS MAY HAVE BEEN ENLARGED OR REDUCED FROM THE ORIGINAL.
THE GRAPHIC SCALE IS PROVIDED FOR REFERENCE.

REVISIONS			
NO.	DATE	BY	DESCRIPTION
C	9/7/2023	JG	ISSUED FOR 90% REVIEW
0	10/16/2023	JG	ISSUED FOR BID
0A	10/31/2023	JG	RE-ISSUED FOR BID
D	1/1/2024	JG	RE-ISSUED FOR REVIEW

OPERATING CENTER: BLOOMINGTON		DIVISION: VEDIN	
PROJECT#: 7604.5050	SCALE: 1" = 100'		
CITY / TOWNSHIP: BLOOMINGTON	COUNTY: MONROE	STATE: IN	

10IN & 8IN NS5059 DOLAN TO IJ PRESSURE TEST & RETROFIT PIPELINE ALIGNMENT		
EnSiteUSA DWG NO. 1011	SHEET NO. 10	REV. D



DISCLAIMER: ENSITEUSA MAKES NO GUARANTEE THAT THIS SURVEY OR THESE MAPS CONTAINS COMPLETE OR CONCLUSIVE UNDERGROUND OR ABOVEGROUND UTILITY INFORMATION. THE CONTRACTOR IS RESPONSIBLE FOR VERIFYING THE LOCATION & PRESERVATION OF ALL UNDERGROUND AND ABOVEGROUND UTILITIES WHETHER OR NOT DEPICTED ON THESE DRAWINGS. THE CONTRACTOR IS TO CONTACT ALL OWNERS OF UNDERGROUND AND ABOVEGROUND UTILITIES PRIOR TO ANY EXCAVATION.

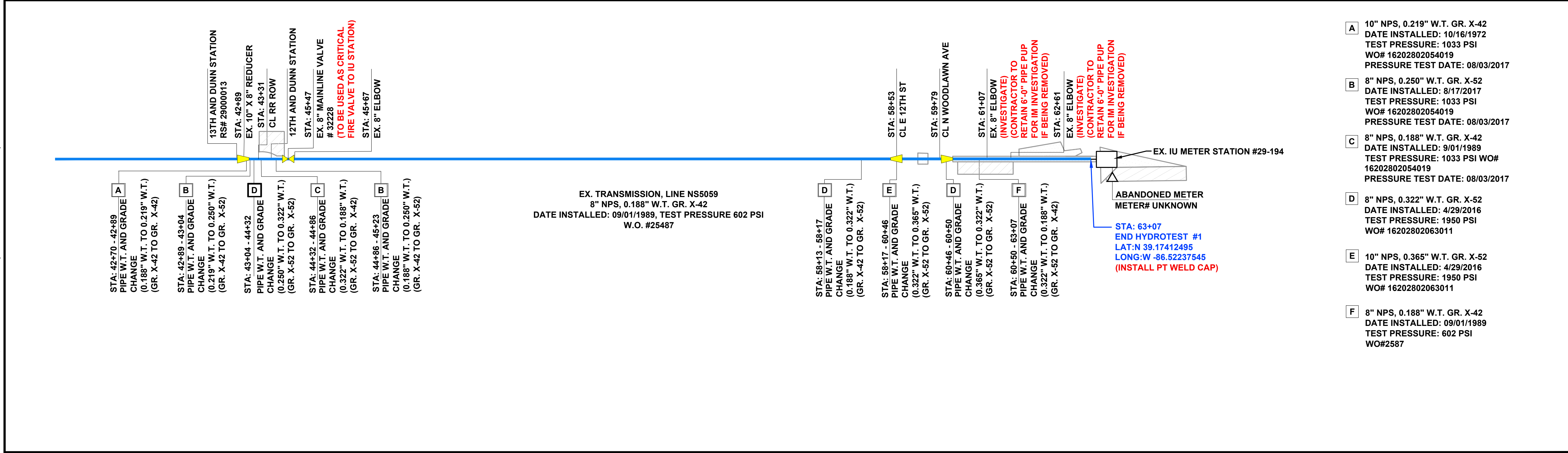
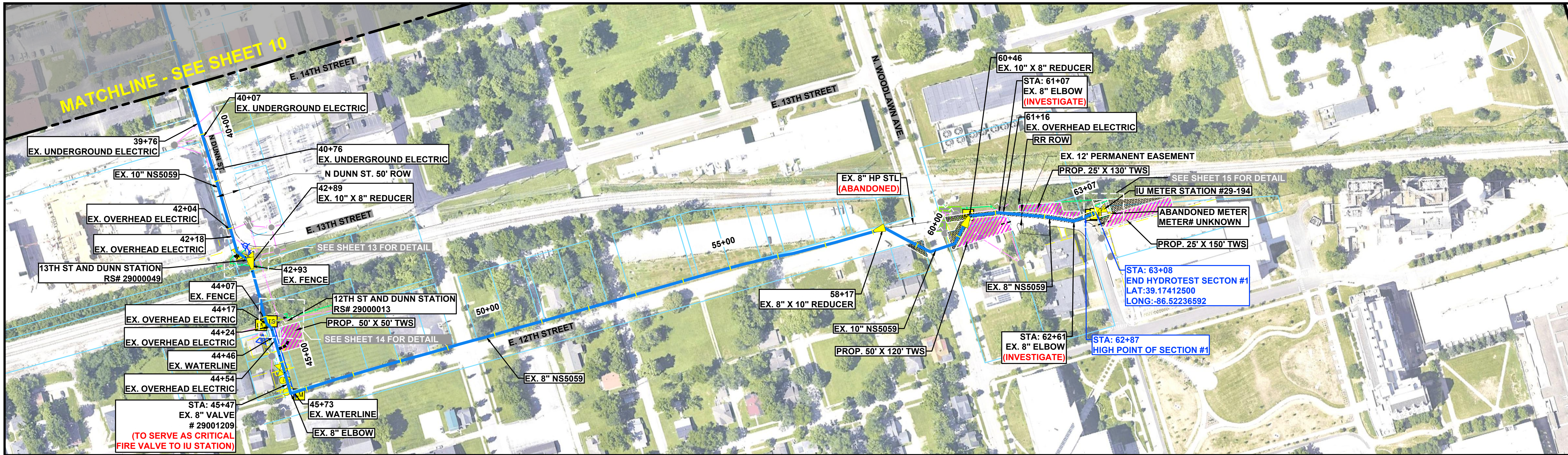

- A** 10" NPS, 0.219" W.T. GR. X-42
DATE INSTALLED: 10/16/1972
TEST PRESSURE: 1033 PSI
WO# 16202802054019
PRESSURE TEST DATE: 08/03/2017
- B** 8" NPS, 0.250" W.T. GR. X-52
DATE INSTALLED: 8/17/2017
TEST PRESSURE: 1033 PSI
WO# 16202802054019
PRESSURE TEST DATE: 08/03/2017
- C** 8" NPS, 0.188" W.T. GR. X-42
DATE INSTALLED: 9/01/1989
TEST PRESSURE: 1033 PSI
WO# 16202802054019
PRESSURE TEST DATE: 08/03/2017
- D** 8" NPS, 0.322" W.T. GR. X-52
DATE INSTALLED: 4/29/2016
TEST PRESSURE: 1950 PSI
WO# 16202802063011
- E** 10" NPS, 0.365" W.T. GR. X-52
DATE INSTALLED: 4/29/2016
TEST PRESSURE: 1950 PSI
WO# 16202802063011
- F** 8" NPS, 0.188" W.T. GR. X-42
DATE INSTALLED: 09/01/1989
TEST PRESSURE: 602 PSI
WO#2587

RE-ISSUED FOR REVIEW
 NOT FOR CONSTRUCTION
 1/1/2024

NOTE: DRAWINGS MAY HAVE BEEN ENLARGED OR REDUCED FROM THE ORIGINAL. THE GRAPHIC SCALE IS PROVIDED FOR REFERENCE.

REVISIONS				OPERATING CENTER:	DIVISION:
NO.	DATE	BY	DESCRIPTION	BLOOMINGTON	VEDIN
C	9/7/2023	JG	ISSUED FOR 90% REVIEW	PROJECT#: 7604.5050	SCALE: 1" = 100'
0	10/16/2023	JG	ISSUED FOR BID		
0A	10/31/2023	JG	RE-ISSUED FOR BID	CITY / TOWNSHIP: BLOOMINGTON	STATE: IN
D	1/1/2024	JG	RE-ISSUED FOR REVIEW		

10IN & 8IN NS5059 DOLAN TO IU
PRESSURE TEST & RETROFIT
PIPELINE
ALIGNMENT

EnSiteUSA DWG NO. 1013 SHEET NO. 12 REV. D

DISCLAIMER: ENSITEUSA MAKES NO GUARANTEE THAT THIS SURVEY OR THESE MAPS CONTAINS COMPLETE OR CONCLUSIVE UNDERGROUND OR ABOVEGROUND UTILITY INFORMATION. THE CONTRACTOR IS RESPONSIBLE FOR VERIFYING THE LOCATION & PRESERVATION OF ALL UNDERGROUND AND ABOVEGROUND UTILITIES WHETHER OR NOT DEPICTED ON THESE DRAWINGS. THE CONTRACTOR IS TO CONTACT ALL OWNERS OF UNDERGROUND AND ABOVEGROUND UTILITIES PRIOR TO ANY EXCAVATION.

K:\7604_5050_Bin\NS5059-PL-17604_5050_10131102024_1.25.03 PNL Saved 12/22/2023 1:26:04 PM by TPOLEH, Last Plot 1/10/2024 1:25:03 PM by CHAD SALLEE

Figure 6H-3. Work on the Shoulders (TA-3)

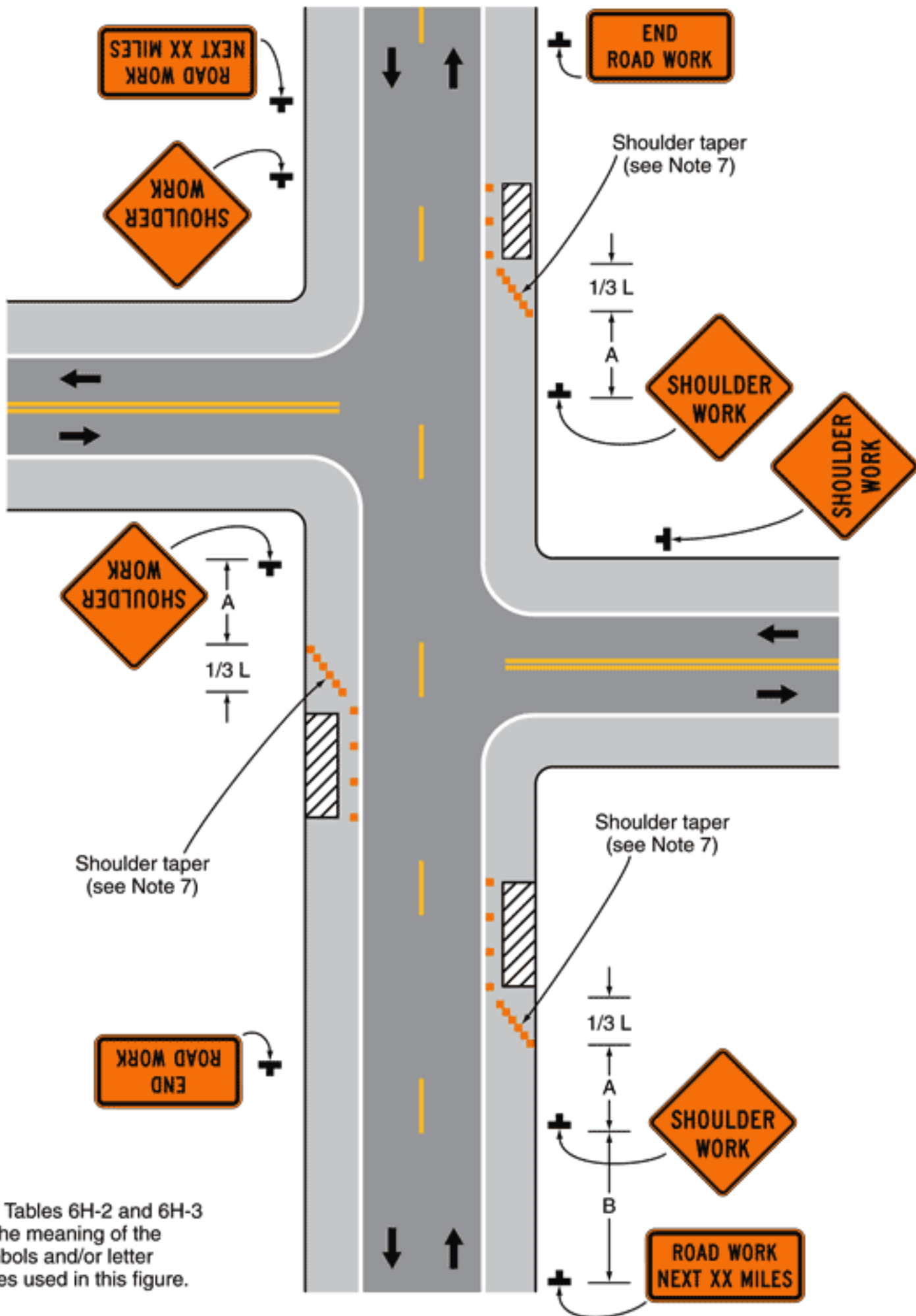

Note: See Tables 6H-2 and 6H-3 for the meaning of the symbols and/or letter codes used in this figure.

Typical Application 3

Figure 6H-28. Sidewalk Detour or Diversion (TA-28)

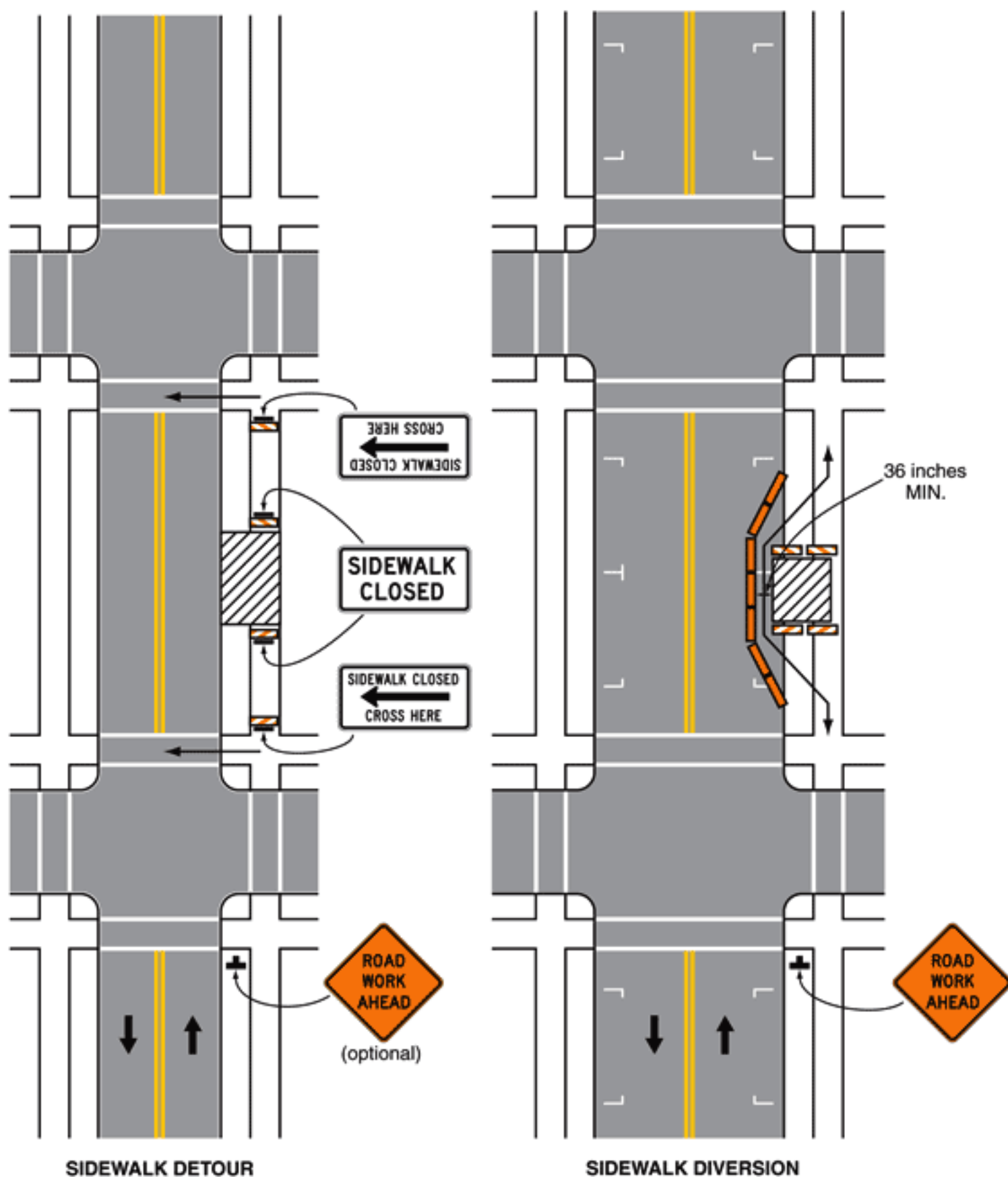

Typical Application 28

Note: See Tables 6H-2 and 6H-3 for the meaning of the symbols and/or letter codes used in this figure.

Figure 6H-34. Lane Closure with a Temporary Traffic Barrier (TA-34)

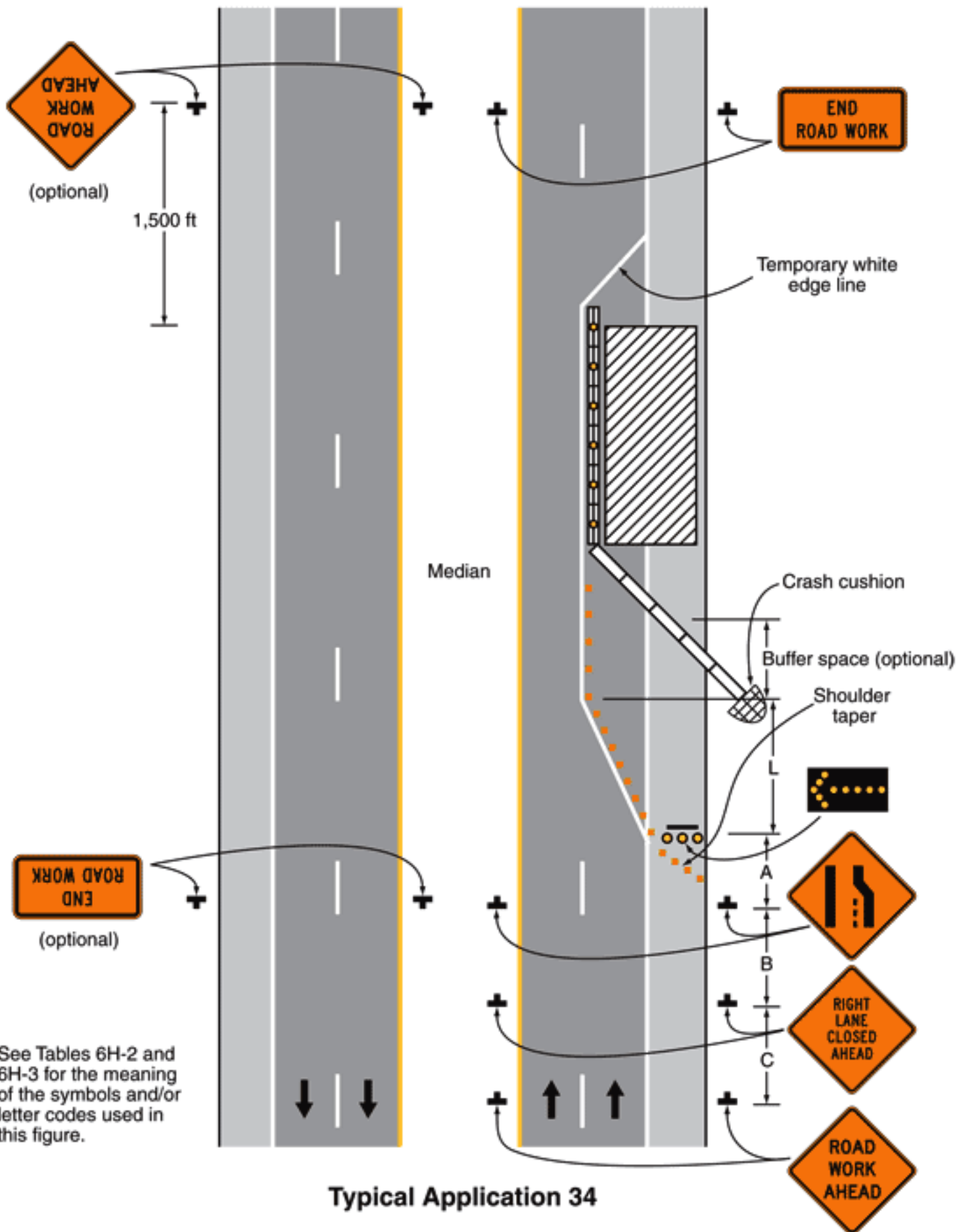

Note: See Tables 6H-2 and 6H-3 for the meaning of the symbols and/or letter codes used in this figure.



Board of Public Works Staff Report

Project/Event: W 1st St Natural Gas Pipe Retirements
Staff Representative: Kyle Baugh
Petitioner/Representative: Robin Cooper
Date: March 12st, 2024

Report: Miller Pipeline is requesting lane closures for the eastbound lane of W 1st St in the 600-800 blocks for pavement excavations that will allow them to access the natural gas pipelines and retire them.

Traffic control has been in place since 3/8/24 with a two week approval from the city engineer. This request would cover the remaining duration of the closure which is expected to be complete by 4/19/24.

Engineering staff is also requesting that the permit fees be waived for this application due to the association with the Hopewell project.



City of Bloomington
 Engineering Department
 bloomington.in.gov

401 N Morton ST Suite 130
 PO Box 100
 Bloomington IN 47404

Phone: (812) 349-3913
 Fax: (812) 349-3520
 engineering@bloomington.in.gov

ROW2024-02-0727
 Type: **Right of Way**
 Work Class: **Right of Way Use**
 Status: **Issued**
 Issued: **2/29/2024**
 Expires: **4/19/2024**
 Updated: **2/29/2024**
 Updated By: **Kyle Baugh**
 Inspector: **Kyle Baugh**

619 W 1st ST

RIGHT OF WAY WORK ON NORTH SIDE OF 1ST ST FROM 619 W 1ST ST TO 827 W 1ST ST POSSIBLE HOLE IN ROAD FOR TIE IN. LANE RESTRICTIONS MOVING WORK ZONE DAILY

Company

Tracy Smith

 (812) 330-4012
 Tracy.Smith@centerpointenergy.com

Applicant

Robin Cooper
 1762 N. Graham Rd
 Franklin IN 46131
 (502) 396-5764
 robin.cooper@millerpipeline.com

Fee	Amount	Paid	Due
Non Pavement	\$320.00	\$0.00	\$320.00
Application - Right of Way	\$100.00	\$0.00	\$100.00
	\$420.00	\$0.00	\$420.00

Location	Type	Description	Length	Width	Depth
W 1ST ST IN GRASS	Non-Pavement Excavations		400	8	9

Special Provisions

- Engineering staff is approving the lane closure for 2 weeks. The remaining four weeks of requested closure duration will require Board of Public Works approval and will be taken to the board on 3/12/24.
- Staff will issue this permit prior to the invoice being paid and will request that the Board of Public Works wave the fees associated with the work at the 3/12/24 meeting date due to its association with a city project.

Standards Conditions of Approval

- 1) The applicant must identify the exact date(s) for which the work will take place. If an exact date(s) isn't provided with the permit application, the permit holder is required to contact City of Bloomington Engineering staff with the request at least 72 hrs BEFORE a closure begins. The City of Bloomington Engineering staff reserves the right to decline the request, or modify the previously approved terms of the permit, if the request cannot be accommodated. Permittees are required to notify Engineering staff if the permitted dates can no longer be adhered to.
- 2) ALL EXCAVATIONS must be inspected by City of Bloomington Engineering staff. Contact the inspector by phone number listed on each permit. The general contact number is (812) 349-3913.
- 3) Contact the Utility Coordinator at the City of Bloomington Utilities Department if placing a new or working on an existing sanitary sewer lateral or water line/meter placement at (812)349-3930.
- 4) This permit does not authorize the closure of any metered or permit parking zones unless expressly stated. Contact Parking Services if the work will require the closure of metered or permit parking zones at 812-349-3436.
- 5) Any brick or inlaid limestone sidewalks or brick-surfaced streets shall remain undisturbed, unless specific permission is requested by the permit holder and granted by the City. Work on these facilities are subject to historic preservation approvals. If these facilities are disturbed: The surface material shall be taken up, saved, and re-installed to City of Bloomington specifications. Backfill methods and materials must also meet these specifications.
- 6) This approval only covers concerns within the jurisdictions of the City of Bloomington Engineering Department. It is the responsibility of the applicant to identify, and apply for any additional permits that other entities or agencies may also need to grant approval for.
- 7) Projects shall conform to all current A.D.A.(Americans with Disabilities Act) and PROWAG (Public Rights-of-Way Accessibility Guidelines) standards.
- 8) All utility work shall conform to specifications to be obtained from the owner of the affected utility, and work on said utility shall be performed only with expressed permission of its owner. It shall be the responsibility of the permittee to obtain any necessary inspections or approvals from the owner of the utilities involved.
- 9) All required traffic control measures shall be in place before work begins. The permittee shall be responsible for supplying and placing all required signs and barricades. The City of Bloomington Engineering staff reserves the right to require modifications to a previously approved traffic control plan if deficiencies or enhancements are identified in the implementation. City of Bloomington staff may require the permittee to secure the excavations and vacate the right-of-way until such time that the modifications can be made.
- 10) Any work in the right-of-way shall conform to the City of Bloomington Standards and Specifications. Copies of these requirements and other resources are available from the Engineering Department or at 'Public Right of Way Permits and Resources' found at the following webpage: <https://bloomington.in.gov/engineering/resources>. All damaged Public Improvements must be repaired to prior conditions or improved conditions.
- 11) Any damage to any underground facility or utility must be reported immediately to the City of Bloomington Engineering Department and the owner of the facility or utility (if known). If not, the permittee may be required to re-excavate the damaged facility or utility, at their expense, to demonstrate that repairs have been made to the satisfaction of the owner of the damaged facility or utility. Permittee shall be responsible for all costs associated to the repair of any damage of City-owned utilities, signs, or other appurtenances that results from the use or excavation of the Right-of-Way.
- 12) All existing signs, or appurtenances (STOP, YIELD, NO PARKING, bollards, parking meters, etc.) that are owned by the City of Bloomington shall be removed and replaced only by the City of Bloomington personnel unless previously approved by the City Engineer or their designee. Any unapproved signs removed, or installed, by the permittee are subject to removal or replacement with permittee being billed for time and materials.
- 13) All existing pavement markings (crosswalks, edge lines, etc) that are disturbed within the Right-of-Way shall be replaced at the direction of the City Engineer or their designee.
- 14) Permittee should backfill pavement excavations and excavations adjacent to multimodal transportation facilities when work is not actively occurring. If excavations cannot be backfilled, permittee shall notify the Engineering Department when steel plates are to be used within the Right-of-Way. The permittee is responsible for providing the specification and placement of steel plates to Engineering staff for approval prior to placement.
- 15) Permittee shall be responsible for repairing any damage to both paved and unpaved portions of the Right-of-Way that results from either the excavation or use of the Right-of-Way in accordance with all City Standards.

Sign \triangle
Sign \triangle
Sign \triangle

* NOTE
ZONE will BE SMALLER
But will MOVE WEST DAILY.

MAPLE

FAIRVIEW

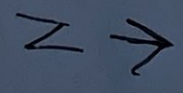
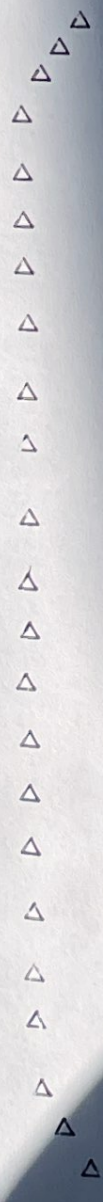

W. 1ST

\triangle sign
 \triangle sign
 \triangle sign



Board of Public Works Staff Report

Project/Event: Crew Carwash
Staff Representative: Kyle Baugh
Petitioner/Representative: Katherine Rayner
Date: March 12, 2024

Report: Crew Carwash is requesting sidewalk and bike lane closures on the east side of N Pete Ellis Dr as part of the redevelopment project located at the corner of N Pete Ellis Dr and E 3rd St. This request is to sidewalk and curb reconstruction. The traffic control would be in place from 6/24/24 through 6/28/24.



Crew Carwash, Inc.
11700 Exit Five Parkway
Fishers, IN 46037

March 5, 2024

Via Electronic Delivery

Board of Public Works
City of Bloomington
401 North Morton Street
Bloomington, IN 47404

RE: Pete Ellis Dr. requested closure

Dear Board Members:

Crew Carwash is planning a redevelopment project at the northeast corner of 3rd St. and Pete Ellis Dr. To facilitate this project, Crew Carwash is respectfully requesting the closure on the eastern sidewalk of the Crew Carwash property for a few business days. The estimated timeline for this project is listed below.

- June 10- June 19, 2024, we will shut down the sidewalk, only, on State Rd 46 (3rd Street). We will block off the 3 approaches on 3rd Street. We will demo the existing sidewalks, landscape, etc to complete the storm structure work. The storm structure work will involve Structures 13, 12, 11, and 16, including pipes to connect. This work will take 8 business days. The total shutdown with weekends is 10 days.
- June 20-June 22, 2024 (Thursday – Saturday) we will shut down one lane of State Rd 46 (3rd Street).
 - 6/20/24 Demo approaches and curbs on 3rd Street
 - 6/21/24 place new curb & gutter on 3rd Street, along with any tie in curb
 - 6/22/24 open the lane on 3rd Street but will have cones on the new curb & gutter that was placed on 6/21 to avoid traffic.
 - 6/24/24 Remove cones placed on new curb & gutter
- June 24 – Shut down the bike lane and sidewalks on Pete Ellis Drive (only the bike lane – not the street)
- June 28 – Open the bike lane.
- Remainder of the concrete to be placed inside the curbs at street levels will then take place, which involves no closures

Crew Carwash will coordinate with the City of Bloomington and City of Bloomington Utilities, law enforcement, and transit providers to ensure that this restriction and closure information is well communicated.

Kinds regards,

Travis Smith

Director of Real Estate and Development
Mobile: 989-464-5693
11700 Exit 5 Pkwy Ste.100
Fishers, IN 46037-8003

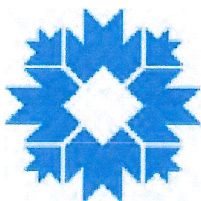

CITY OF BLOOMINGTON

RIGHT-OF-WAY USE PERMIT APPLICATION

401 N Morton Street, Suite 130
P.O. Box 100
Bloomington, IN 47402

Phone: (812) 349-3913
Fax: (812) 349-3520
Email: engineering@bloomington.in.gov

ROW EXCAVATION ROW USE

ADDRESS OF ROW ACTIVITY: _____

<p>A. APPLICANT/AGENT INFORMATION:</p> <p>APPLICANT NAME: <u>Crew Carwash</u></p> <p>E-MAIL: <u>Katherine.Rayner@Crewcarwash.com</u></p> <p>COMPANY: <u>Crew Carwash</u></p> <p>ADDRESS: <u>11700 Exit 5 Rkywy Ste. 100</u></p> <p>CITY, STATE, ZIP: <u>Fishers, IN 46037</u></p> <p>24-HR EMERGENCY CONTACT NAME: <u>T.B.D</u></p> <p>24-HR CONTACT PHONE #: <u>T.B.D</u></p> <p>INSURANCE #*: _____ COMPANY: _____</p> <p>BOND #*: _____ COMPANY: _____</p> <p><small>* INSURANCE & BOND MUST BE ON FILE WITH THE CITY BEFORE PERMIT WILL BE ISSUED</small></p> <p style="text-align: center;">**SUBCONTRACTOR INFORMATION**</p> <p>(LIST ALL COMPANIES WORKING UNDER PRIMARY CONTRACTOR PERMIT)</p> <p>COMPANY NAME: <u>T.B.D</u></p> <p>B. WORK DESCRIPTION:</p> <p><input type="checkbox"/> POD/DUMPSTER <input type="checkbox"/> CRANE <input type="checkbox"/> SCAFFOLDING <input checked="" type="checkbox"/> CONSTRUCTION USE*</p> <p>(EXPLAIN): <u>Sidewalk construction associated w/Dev.</u></p> <p><small>*EXCAVATION, LONG TERM USE FOR STORAGE OF MATERIAL/EQUIPMENT/WALKAROUND</small></p> <p>C. RIGHT OF WAY TO BE USED/CLOSED:</p> <p>STREET NAME 1: <u>S. Pete Ellis Drive</u></p> <p>1ST INTERSECTING STREET NAME: <u>E. 3rd Street</u></p> <p>2ND INTERSECTING STREET NAME: <u>E. Longview Ave</u></p> <p><input type="checkbox"/> ROAD CLOSURE <input type="checkbox"/> LANE CLOSURE 1 <input type="checkbox"/> 2 <input type="checkbox"/> 3</p> <p><input checked="" type="checkbox"/> SIDEWALK* <input type="checkbox"/> BIKE LANE <input type="checkbox"/> OTHER</p> <p>TRANSIT STOP? <input type="checkbox"/> Y <input checked="" type="checkbox"/> N PARKING LANE(S)** <input type="checkbox"/> Y <input checked="" type="checkbox"/> N <small>**NON-METERED</small></p> <p>START DATE: <u>April 2024</u> END DATE: <u>April 2025</u> # OF DAYS*: <u>730</u></p> <p>STREET NAME 2: _____</p> <p>1ST INTERSECTING STREET NAME: _____</p> <p>2ND INTERSECTING STREET NAME: _____</p> <p><input type="checkbox"/> ROAD CLOSURE <input type="checkbox"/> LANE CLOSURE 1 <input type="checkbox"/> 2 <input type="checkbox"/> 3</p> <p><input type="checkbox"/> SIDEWALK* <input type="checkbox"/> BIKE LANE <input type="checkbox"/> OTHER</p> <p>TRANSIT STOP? <input type="checkbox"/> Y <input type="checkbox"/> N PARKING LANE(S)** <input type="checkbox"/> Y <input type="checkbox"/> N <small>**NON-METERED</small></p> <p>START DATE: _____ END DATE: _____ # OF DAYS*: _____</p> <p><small>*SIDEWALK CLOSURES FOR A PERIOD OR PERIODS TOTALING 24HRS OR MORE SHALL INSTALL A WALKAROUND UNLESS OTHERWISE APPROVED DURING REVIEW</small></p> <p>STANDARD CLOSURE HOURS MON-FRI*: 9:00 AM - 3:00 PM & 6:00 PM - 9:00 PM</p> <p>STANDARD CLOSURE HOURS <input type="checkbox"/> *NON-STANDARD CLOSURE HOURS <input type="checkbox"/></p> <p>REQUESTED CLOSURE HOURS: _____ AM - _____ PM</p> <p><small>*non-standard hours may not be allowed near schools, on arterials, or other circumstances and are subject to approval during the permitting process</small></p> <p><small>BMC 14.09.040 allows work from 6 AM to 10 PM without violating the noise ordinance (7AM to 9PM for pneumatic hammers)</small></p>	<p>D. TRAFFIC CONTROL DEVICES*:</p> <p><input type="checkbox"/> CONES <input type="checkbox"/> ARROWBOARD</p> <p><input checked="" type="checkbox"/> LIGHTED BARRELS <input type="checkbox"/> TYPE 3 BARRICADES</p> <p><input type="checkbox"/> FLAGGERS <input type="checkbox"/> BPD OFFICER</p> <p><small>*PROVIDING MUTCD COMPLIANT TEMPORARY TRAFFIC CONTROL DEVICES AND MAINTENANCE OF TRAFFIC (MOT) PLAN IS YOUR RESPONSIBILITY AND REQUIRED</small></p> <p><small>See page 3 for additional MOT resources; the graph paper can be used for your MOT site plan if needed or you can submit a separate sheet</small></p> <p>E. METERED PARKING SPACES NEEDED: <input type="checkbox"/> Y <input checked="" type="checkbox"/> N</p> <p>IT IS THE RESPONSIBILITY OF THE APPLICANT TO RESERVE PARKING METER(S) APPLICATION LOCATED: https://bloomington.in.gov/transportation/parking/ moving OR CONTACT PARKING SERVICES WITH QUESTIONS AT (812)349-3436</p> <p>F. IS THIS A <input type="checkbox"/> CBU* <input type="checkbox"/> COUNTY* <input type="checkbox"/> IU* <input type="checkbox"/> NP* PROJECT?</p> <p>PROJECT NAME: _____</p> <p>PROJECT #: _____</p> <p>PROJECT MGR.: _____</p> <p>PROJECT MGR. #: _____</p> <p><small>*CBU = CITY OF BLOOMINGTON UTILITIES *COUNTY = MONROE COUNTY</small></p> <p><small>*IU = INDIANA UNIVERSITY *NP = NOT-FOR-PROFIT AGENCY</small></p> <p>G. EXCAVATIONS:</p> <p>SQ FT OF PAVEMENT* EXCAVATIONS: <u>3,841</u></p> <p><small>*PAVEMENT INCLUDES: IN OR UNDER CONCRETE, OR ASPHALT INCLUDING CURBS</small></p> <p>SQ FT OF NON-PAVEMENT* EXCAVATIONS: <u>2,700 223</u></p> <p><small>*DIRT, GRASS, GRAVEL, LANDSCAPE AREA OR OTHER UNPAVED SURFACE</small></p> <p>LINEAL FT OF BORE*: _____</p> <p><small>*BORE PITS SHALL BE CALCULATED AS SQ FT EXCAVATIONS</small></p> <p># OF POLE INSTALLATIONS/REMOVAL: <u>0</u></p> <p>SQ FT OF SIDEWALK RECONSTRUCTION*: <u>418</u></p> <p><small>*CONCRETE OR ASPHALT SIDEWALK/PATH BEING IMPROVED/REPLACED</small></p> <p>SQ FT OF SIDEWALK NEW CONSTRUCTION*: <u>4707 1,349</u></p> <p><small>*CONCRETE OR ASPHALT SIDEWALK/PATH THAT IS NEW INFRASTRUCTURE</small></p> <p># RESIDENTIAL DRIVEWAY INSTALLATION: <u>0</u></p> <div style="border: 1px solid black; padding: 5px; margin-top: 10px;"> <p style="text-align: center;">Indiana 811</p> <p style="text-align: center;"><small>Know what's below. Call before you dig.</small></p> </div> <p style="font-size: small;">TO SUBMIT A LOCATE REQUEST 24 HRS A DAY, 7 DAYS A WEEK CALL 811 OR 800-382-5544 CALL 2 WORKING DAYS BEFORE YOU DIG. IT'S THE LAW.</p> <p>H. INDEMNIFICATION AGREEMENT:</p> <p>The petitioner/applicant hereby agrees to hold harmless, defend and to indemnify the City of Bloomington from or against all claims, action, damages and expenses, including but not limited to reasonable attorney's fees or any alleged injury and/or death to any person or damage to any property arising, or alleged to have arisen out of any act of commission or omission on the part of the petitioner/applicant, his/her heirs, successors, or assigns regardless of whether such acts are the direct or indirect result of the public right-of-way use pursuant to this permit grant.</p> <p>I AFFIRM, UNDER THE PENALTIES FOR PERJURY, THAT THE FOREGOING REPRESENTATIONS ARE TRUE.</p> <p>PRINT NAME: <u>Anthony Willis</u></p> <p>SIGNATURE: <u>[Signature]</u></p> <p>DATE: <u>11/21/23</u></p>
---	---

For Administration Use Only (applicable to CLOSURE approval)

Approved By: _____ BPW City Engineer Director Date: _____

Staff Representative: _____ Phone#: _____ Date: _____

PROPOSED: CREW CARWASH

PART OF THE SW $\frac{1}{4}$ OF SECTION 35,
TOWNSHIP 9N, RANGE 1W, MONROE
COUNTY, INDIANA

2901 E. 3RD STREET
BLOOMINGTON, IN., 47401

UTILITY CONTACT INFORMATION

GAS VECTREN 205 S. MADISON ST. BLOOMINGTON, IN 47401 DOUG ANDERSON (812)330-4009	SEWER AND WATER CITY OF BLOOMINGTON UTILITIES 600 E. MILLER DR. BLOOMINGTON, IN 47402 NANCY AXSOM (812)349-3689	ELECTRIC DUKE ENERGY 1619 W. DEFFENBAUGH ROAD KOKOMO, INDIANA 46902 JIM SHIELDS (317)375-2071
TELEPHONE AT&T P.O. BOX 56 BLOOMINGTON, IN 47402 BRENT McCABE (812)334-4521	CABLE TELEVISION COMCAST 2450 SOUTH HENDERSON STREET BLOOMINGTON, IN 47404 SCOTT TEMPLETON (812)355-7822	UNDERGROUND UTILITY LOCATION INDIANA UNDERGROUND PLANT PROTECTION 1-(800)382-5544

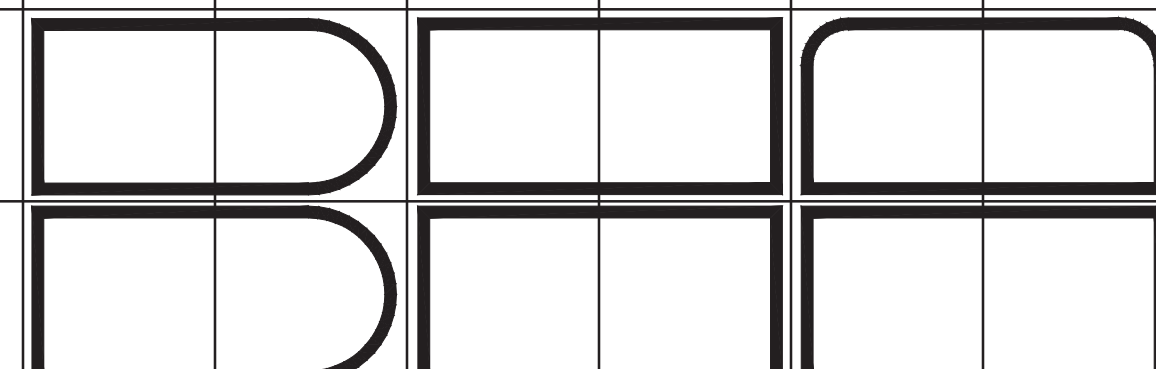

BYNUM FANYO & ASSOCIATES, INC.
528 North Walnut Street
Bloomington, Indiana 47404 (812) 332-8030

SHEET INDEX

SHEET NO.	SHEET NO.
C101	GENERAL NOTES & LEGENDS
C201	DEMOLITION PLAN
C301	SITE & UTILITY PLAN
C401	GRADING & DRAINAGE PLAN
C501-C502	DETAILS
C601-C604	STORM WATER POLLUTION PREVENTION PLAN, INFORMATION, AND DETAILS
C701-C702	STORM SEWER PLAN & PROFILING

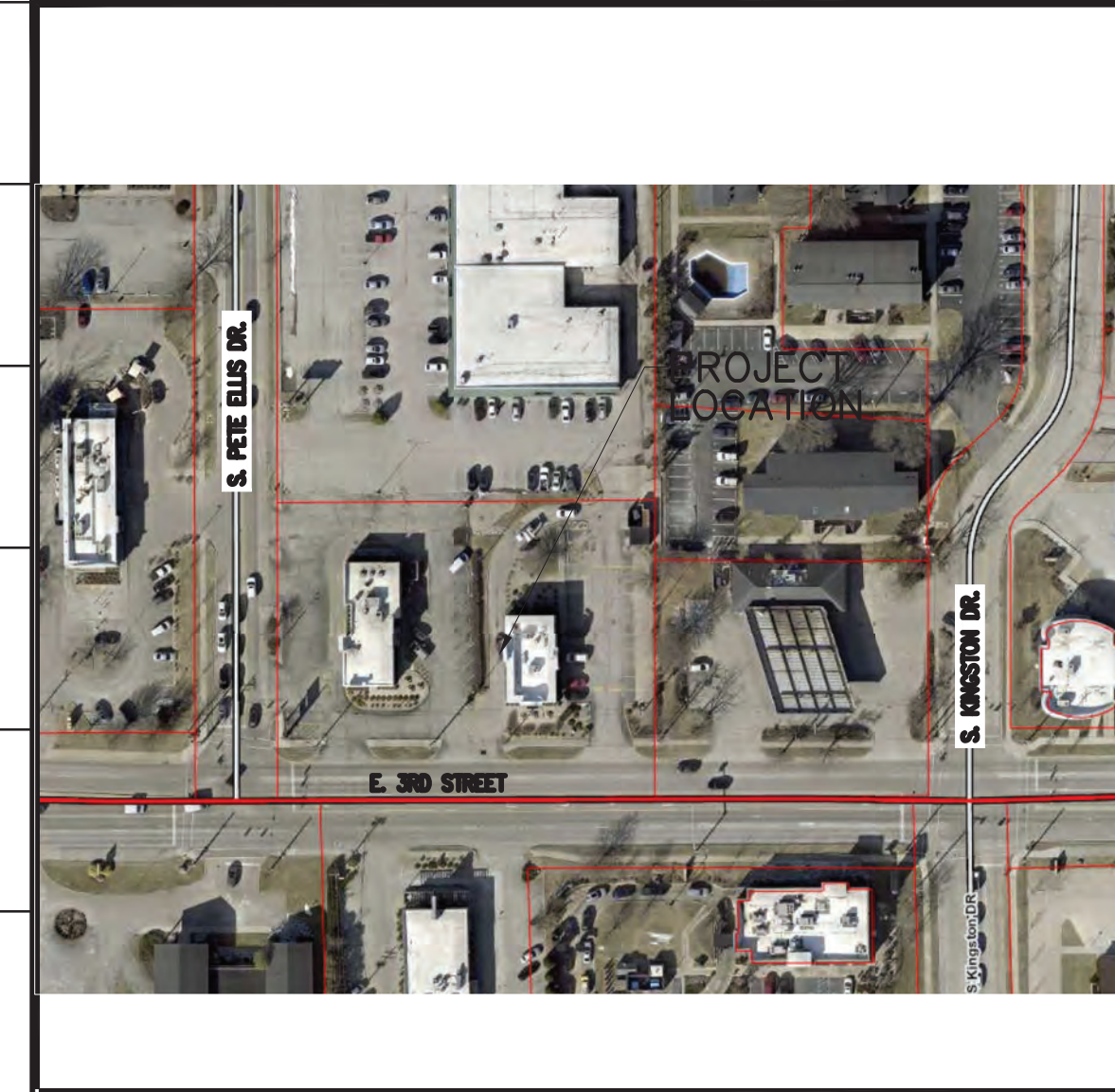

VICINITY/LOCATION MAP
NOT TO SCALE

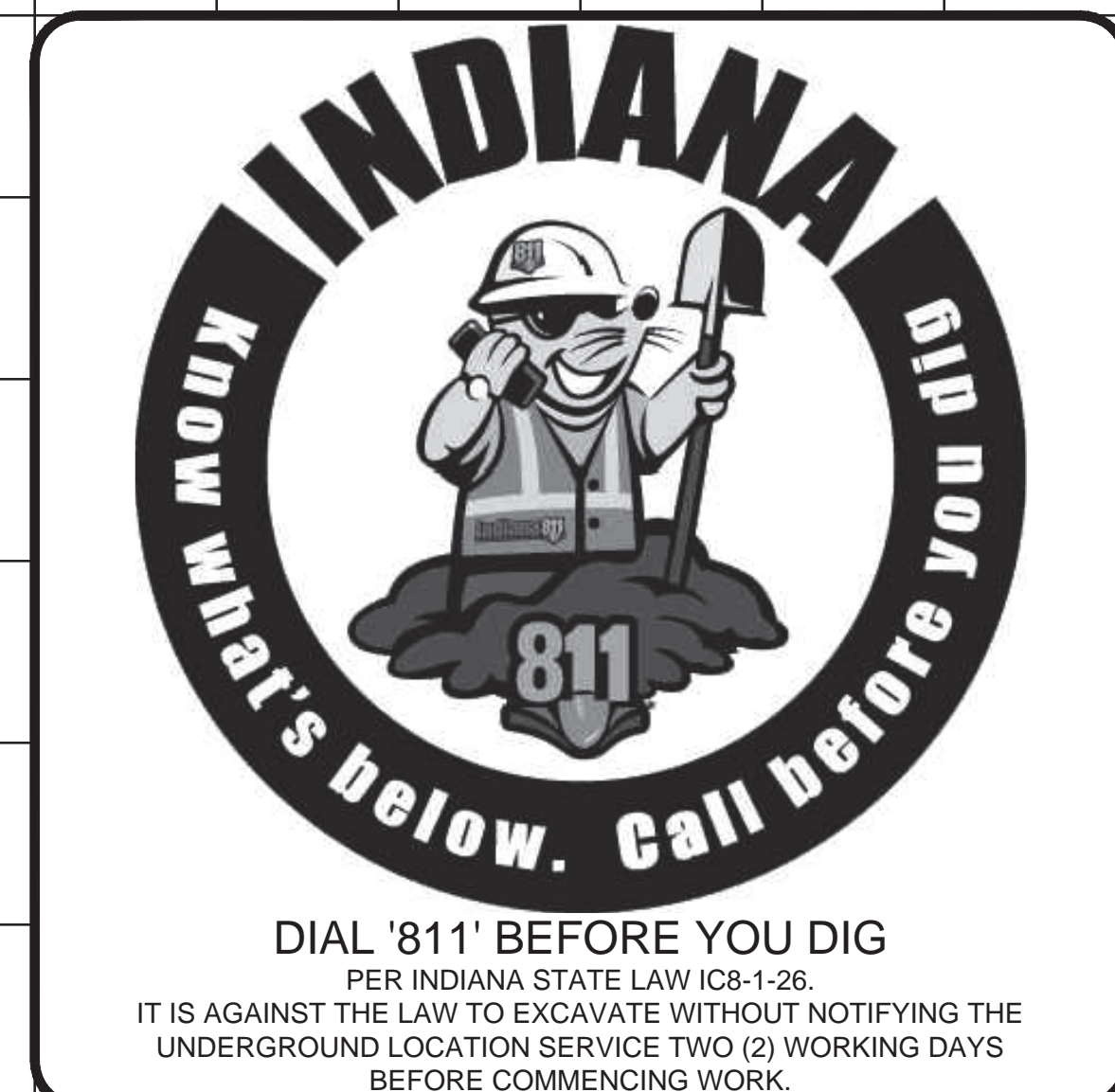

architecture
civil engineering
planning

<p>OWNER/DEVELOPER: CREW CARWASH, INC. 11700 EXIT 5 PKWY STE. 100 FISHERS, IN. 46037</p>	<p>THE CURRENT EDITION OF THE INDIANA DEPARTMENT OF TRANSPORATION, MANUAL ON UNIFORM TRAFFIC CONTROL DEVICES & CITY OF BLOOMINGTON UTILITIES STANDARD SPECIFICATIONS IS TO BE USED WITH THESE PLANS</p>	<p>Certified By: 11.21.23 DANIEL J. BUTLER, P.E. IND. REG. NO. 11500284</p>	<p>Revisions RF11 - SANITARY SEWER MAIN REVISIONS 07.23.21 CREW CARWASH PROJECT NO. 402256</p>
--	---	--	---

Town & County
Apartment II, LLC
Instr. 2004005489

EXISTING LEGEND

EXISTING FENCE	--- X X X ---
EXISTING WATER LINE	--- W ---
EXISTING OVERHEAD UTILITY LINES	--- OHU ---
EXISTING UNDERGROUND ELECTRIC LINES	--- UGE ---
EXISTING UNDERGROUND TELEPHONE LINES	--- UGT ---
EXISTING UNDERGROUND FIBER OPTIC LINES	--- FO ---
EXISTING GAS LINE	--- GAS ---
EXISTING SANITARY FORCEMAIN	--- FM ---
EXISTING CONTOUR	--- XXX ---
FLOW LINE	--->--->---
EXISTING SANITARY SEWER AND MANHOLE	--- (O) ---
EXISTING STORM SEWER AND INLET	--- (S) ---
PROPERTY LINE	--- - - - ---

EXISTING IMPERVIOUS AREA

TOTAL SITE AREA = 48,866 S.F.
 TOTAL EXISTING IMPERVIOUS AREA = 38,330 S.F.
 PERCENT IMPERVIOUS (EXISTING) = 78.4% IMPERVIOUS

DEMOLITION NOTES

CONTRACTOR SHALL REMOVE BOTH EXISTING BUILDINGS INCLUDING THEIR RESPECTIVE PORCHES/CONCRETE, BUILDING FOUNDATIONS, STEPS, AND ASSOCIATED SERVICE LATERALS, METERS, UTILITY UNITS/BOXES & UTILITY LINES. CONTRACTOR SHALL BE RESPONSIBLE FOR REMOVAL OF ANY ABANDONED UTILITY LINES IN PROJECT LIMITS. CONTRACTOR TO BACKFILL WITH COMPACTED INDOT #53 STONE IN ACCORDANCE WITH INDOT SPECIFICATIONS FOR STRUCTURAL BACKFILL AREAS. CONTRACTOR TO SEAL ALL REMAINING OPENINGS IN UTILITY PIPING/CONDUITS OR MANHOLES SCHEDULE TO REMAIN WATER TIGHT PER CITY OF BLOOMINGTON SPECIFICATIONS. NOTIFY THE CITY OF BLOOMINGTON UTILITIES 48 HOURS PRIOR TO REMOVAL. CONTRACTOR TO BE RESPONSIBLE TO ENSURE UTILITY COMPANIES ARE CONTACTED TO REMOVE THEIR APPROPRIATE SERVICE LINES.

CONTRACTOR SHALL REMOVE ALL PAVEMENT, SIDEWALKS, CURBING, AND STONE WITH IN THE PROJECT SITE AREA. CONTRACTOR SHALL SAW-CUT THE PAVEMENT OF THE SHARED PARKING AREA ALONG THE NORTH PROPERTY LINE. CONTRACTOR SHALL PRESERVE PAVEMENT AND STRIPING TO THE NORTH. COORDINATE CONSTRUCTION WITH THE ADJACENT PROPERTY OWNERS TO THE NORTH. CONTRACTOR SHALL REFER TO SHEET C301 FOR THE LIMITS OF PROPOSED PAVEMENT, CURBING, AND SIDEWALKS.

CONTRACTOR SHALL REFER TO THE DEMOLITION PLAN ON THIS SHEET FOR ADDITIONAL DETAILS.

UTILITY REMOVAL NOTE

CONTRACTOR SHALL COORDINATE CUT & CAP OF EXISTING UTILITIES WITH CBU INSPECTOR. CONTRACTOR SHALL CONTACT CBU INSPECTOR A MINIMUM OF 48 HOURS PRIOR TO CUTTING ANY EXISTING UTILITY SERVICE LINES.

NOTE TO CONTRACTOR

CONTRACTOR SHALL VERIFY ALL UTILITY LOCATIONS & DEPTHS AND NOTIFY ENGINEER OF ANY INACCURACIES IN LOCATION OR ELEVATION OR ANY CONFLICTS PRIOR TO & AFTER ANY EXCAVATION. NO PAYMENT SHALL BE MADE TO CONTRACTOR FOR UTILITY DESTRUCTION OR UNDERGROUND CHANGES REQUIRED DUE TO CONFLICTING ELEVATIONS.

revisions:

ARCHITECTURE
CIVIL ENGINEERING
PLANNING

Bloomington, Indiana
(812) 359-2990 (Fax)

BYNUM FANYO & ASSOCIATES, INC.

52B north walnut street
(812) 352-8030

11.21.23

certified by:

**PROPOSED
CREW GARWASH**
2901 E. 3RD STREET
BLOOMINGTON, IN 47401

title: DEMOLITION PLAN

designed by: AJW
drawn by: AJW
checked by: DJB
sheet no: C201
project no.: 402256

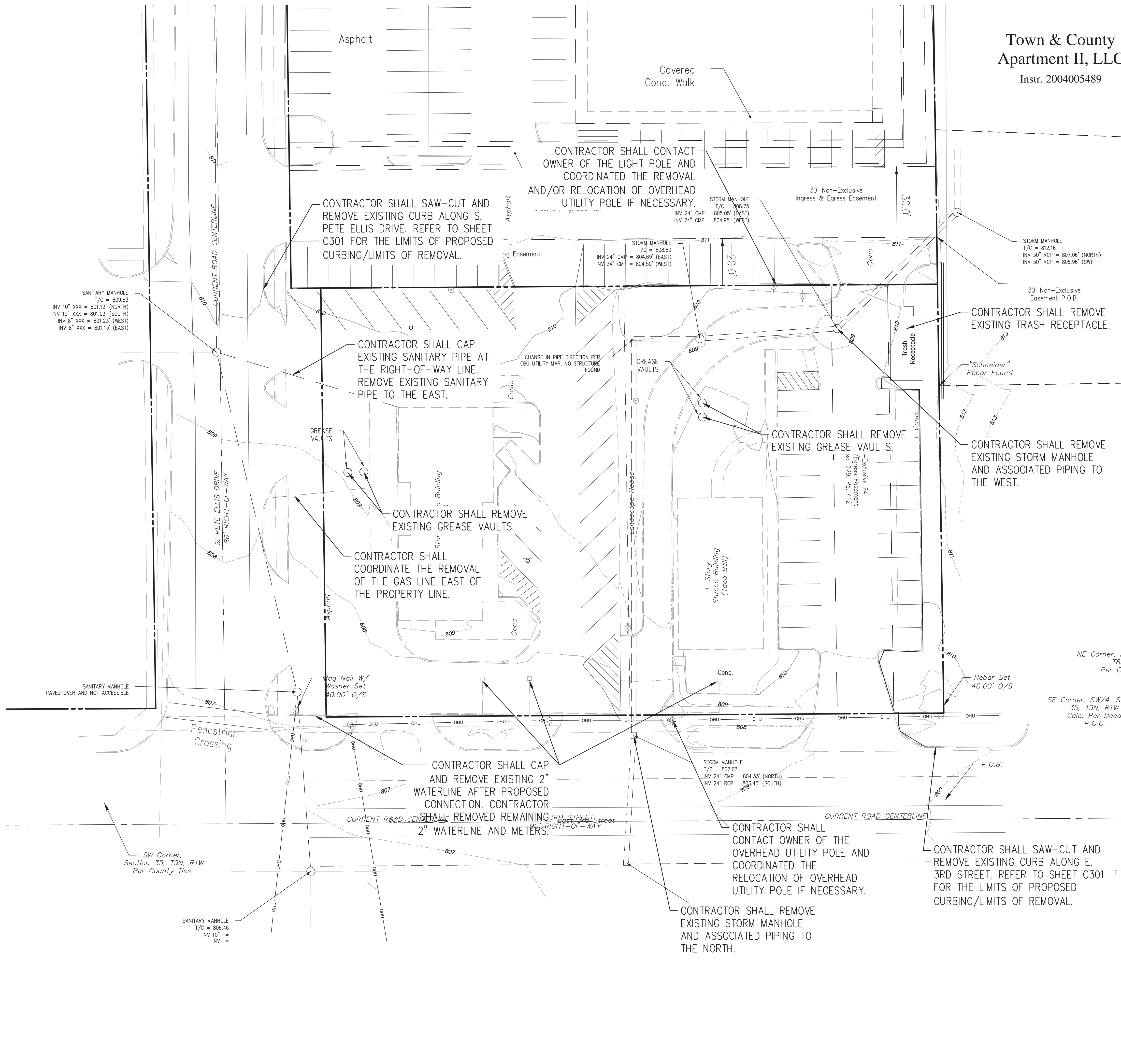
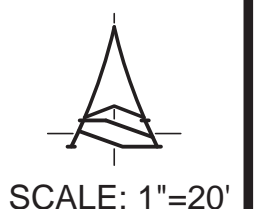

CONTRACTOR SHALL SAW-CUT AND REMOVE EXISTING CURB ALONG S. PETE ELLIS DRIVE. REFER TO SHEET C301 FOR THE LIMITS OF PROPOSED CURBING/LIMITS OF REMOVAL.

CONTRACTOR SHALL CONTACT OWNER OF THE LIGHT POLE AND COORDINATED THE REMOVAL AND/OR RELOCATION OF OVERHEAD UTILITY POLE IF NECESSARY.

CONTRACTOR SHALL REMOVE EXISTING TRASH RECEPTACLE.

CONTRACTOR SHALL CAP EXISTING SANITARY PIPE AT THE RIGHT-OF-WAY LINE. REMOVE EXISTING SANITARY PIPE TO THE EAST.

CONTRACTOR SHALL REMOVE EXISTING GREASE VAULTS.

CONTRACTOR SHALL REMOVE EXISTING STORM MANHOLE AND ASSOCIATED PIPING TO THE WEST.

CONTRACTOR SHALL REMOVE EXISTING GREASE VAULTS.

CONTRACTOR SHALL COORDINATE THE REMOVAL OF THE GAS LINE EAST OF THE PROPERTY LINE.

CONTRACTOR SHALL CAP AND REMOVE EXISTING 2" WATERLINE AFTER PROPOSED CONNECTION. CONTRACTOR SHALL REMOVE REMAINING 2" WATERLINE AND METERS.

CONTRACTOR SHALL CONTACT OWNER OF THE OVERHEAD UTILITY POLE AND COORDINATED THE RELOCATION OF OVERHEAD UTILITY POLE IF NECESSARY.

CONTRACTOR SHALL SAW-CUT AND REMOVE EXISTING CURB ALONG E. 3RD STREET. REFER TO SHEET C301 FOR THE LIMITS OF PROPOSED CURBING/LIMITS OF REMOVAL.

CONTRACTOR SHALL REMOVE EXISTING STORM MANHOLE AND ASSOCIATED PIPING TO THE NORTH.

SANITARY MANHOLE
T/C = 809.83
INV 10" XXX = 801.13' (NORTH)
INV 10" XXX = 801.03' (SOUTH)
INV 8" XXX = 801.23' (WEST)
INV 8" XXX = 801.13' (EAST)

SANITARY MANHOLE
PAVED OVER AND NOT ACCESSIBLE

SANITARY MANHOLE
T/C = 806.46
INV 10" =
INV =

SW Corner,
Section 35, T9N, R1W
Per County Ties

NE Corner, 1/4
T8N
Per Cc

SE Corner, SW/4, Se
35, T9N, R1W
Calc. Per Deed
P.O.C.

P.O.B.

SITE IMPROVEMENT LEGEND

- (A) PROPOSED ASPHALT PAVING - REFER TO DETAIL
- (A1) PROPOSED HMA WEDGE AND LEVEL. REFER TO SPOT GRADES, CONTOURS, AND SLOPE ARROWS ON SHEET C401 FOR FINAL PROPOSED GRADE. CONTRACTOR SHALL CONSTRUCT PAVEMENT WITH 1% MIN. CROSS SLOPE TO ENSURE POSITIVE DRAINAGE. CONTRACTOR SHALL ENSURE NO LOW SPOTS ARE CREATED AND NO PONDING OCCURS. 1 1/2" MILL AND 1 1/2" OVERLAY MINIMUM.
- (C) PROPOSED REINFORCED CONCRETE PAVEMENT - REFER TO DETAIL
- (PP) PROPOSED CITY OF BLOOMINGTON PAVEMENT PATCH REPAIR PAVING - REFER TO DETAIL
- (F) PROPOSED CONCRETE PATIO OR SIDEWALK. REFER TO PLAN FOR LOCATIONS AND REFER TO DETAIL
- (F1) PROPOSED MONOLITHIC CURB AND SIDEWALK - REFER TO DETAIL
- (13) PROPOSED 6" STANDING CURB - REFER TO DETAIL
- (14) PROPOSED 6" CONCRETE ROLL CURB AND GUTTER - REFER TO DETAIL
- (15) PROPOSED 6" CONCRETE CURB AND GUTTER - REFER TO DETAIL
- (DC) PROPOSED DEPRESSED CURB - CONTRACTOR TO REFER TO DETAIL FOR 'CONCRETE STANDING CURB' BUT WITH 0" CURB HEIGHT TO CREATE A CURB LOOK WHERE INDICATED
- (CT) PROPOSED CONCRETE CURB TRANSITION, 6' LENGTH FROM 0" TO 6" CURB HEIGHT
- (CU) CONCRETE CURB DRAINAGE TURN-OUT - REFER TO DETAIL
- (R1) PROPOSED INDOT SIDEWALK ACCESSIBLE RAMP - REFER TO DETAIL
- (R2) PROPOSED SIDEWALK ACCESSIBLE RAMP TYPE 'C' - REFER TO DETAIL
- (R3) PROPOSED SIDEWALK ACCESSIBLE RAMP TYPE 'H' - REFER TO DETAIL
- (20) DRIVE-THROUGH LANE MARKING, PAINTED, SOLID, YELLOW, 6" WIDE
- (21) PROPOSED PARKING MARKING, PAINTED, SOLID, WHITE, 4" WIDE
- (21A) PROPOSED ADA PARKING MARKING, PAINTED, SOLID, BLUE - REFER TO DETAIL
- (29) PROPOSED PAVEMENT MARKING, PAINTED, CROSS HATCH, WHITE, 6" WIDE SPACED AT 3' O.C. IN LIMITS SHOWN
- (APS) ACCESSIBLE PARKING SIGN, REFER TO DETAIL
- (VA) VAN ACCESSIBLE SUPPLEMENTAL SIGN ACCORDING TO NATIONAL ADA STANDARDS - FASTEN BELOW HANDICAP PARKING SIGN WHERE INDICATED, REFER TO DETAIL
- (W1-15) PROPOSED INDOT 30" x 30" ROAD 'BICYCLE/PEDESTRIAN' SIGN WITH YELLOW BACKGROUND - REFER TO SIGN DETAIL ON SHEET C501, THESE SIGN LOCATIONS SHALL BE TWO SIGNS (DOUBLE SIDED ON SAME POST)
- (38) PROPOSED CROSSWALK PAVEMENT MARKING, THERMOPLASTIC, SOLID, 24" WIDE, 24" SPACING, WHITE, WIDTH TO MATCH SIDEWALK, SEE PLAN (CROSSWALK PER INDOT STANDARD 808.07)
- (DE) PROPOSED DUMPSTER ENCLOSURE - CONTRACTOR TO REFER TO ARCHITECTURAL PLANS FOR DETAILS AND FURTHER SPECIFICATIONS. REFER TO ALSO TO ARCHITECTURAL PLANS FOR FINAL BOLLARD INFORMATION, DETAILS AND PLACEMENT AROUND AND WITHIN DUMPSTER AREA. CONTACT THE ENGINEER WITH ANY DISCREPANCIES
- (B) PROPOSED BOLLARD - REFER TO DETAIL
- (BP) SURFACE MOUNT TWO (2) ULINE BRAND MODEL H-2892 U-RACKS - REFER TO MANUFACTURER'S RECOMMENDATIONS ON INSTALLATION - SPACING SHALL BE 3' BETWEEN RACKS. THREE (3) BIKE CAPACITY PER U-RACK.
- (S) PROPOSED CONCRETE STAIRS WITH CHEEK WALLS AND HANDRAILS AS INDICATED ON PLANS - REFER TO THESE PLANS FOR DETAILS
- SEE ARCHITECTURAL & STRUCTURAL DRAWINGS FOR ALL SHADED AREAS

UTILITY LEGEND

- PROPOSED PRIVATE DOMESTIC SERVICE LINE: _____ DSL _____
FOR 2-INCH OR LESS SERVICE LINES FROM THE 'WSL' TO THE METER SHALL BE EITHER TYPE 'K' COPPER IN CONFORMANCE WITH ASTM B88 OR BLUE POLYETHYLENE AWWA 901 PE4710, ASTM D2737, CTS SDR9 PC250 (NSF 61). USE SDR-21 AND FITTINGS FOR DOMESTIC WATER SERVICE LINES FROM THE METER TO THE BUILDINGS TO BE SERVED. REFER TO DETAIL FOR CONNECTION TO PROPOSED SANITARY MAIN AS SEEN ON THE PLAN - REFER TO CONNECTION DETAIL, BACKFILL DETAIL OF PROPOSED PIPING, AND CLEANOUT DETAIL. NOTIFY ENGINEER OF ANY DISCREPANCIES BEFORE PARTS ARE ORDERED AND WORK HAS COMMENCED.
- 2" DOMESTIC METER YOKESSETER IN A 30" METER PIT PER CBU STANDARDS - REFER TO DETAIL (CBU STANDARD DETAIL NO. 28) COORDINATE FINAL SIZE OF REQUIRED METER WITH CBU
- PROPOSED ASTM D3034 SDR 35 PVC TO PROPERTY LINE, _____ SSL _____
6" MIN. SANITARY LATERAL AND SANITARY SEWER CLEAN-OUT, REFER TO DETAILS, 24" COVER MIN. REFER TO PLUMBING PLAN FOR PROPOSED INVERT ELEVATIONS LEAVING PROPOSED BUILDING. SLOPE AT 1/4% MIN. TO CONNECTION TO PROPOSED SANITARY MAIN AS SEEN ON THE PLAN - REFER TO CONNECTION DETAIL, BACKFILL DETAIL OF PROPOSED PIPING, AND CLEANOUT DETAIL. NOTIFY ENGINEER OF ANY DISCREPANCIES BEFORE PARTS ARE ORDERED AND WORK HAS COMMENCED.
- SEE ARCHITECTURAL AND STRUCTURAL DRAWINGS FOR ALL SHADED AREAS
- PIPE INVERT ELEVATION (INVERTS GIVEN BY PLUMBING ENGINEER - SEE PLUMBING DRAWINGS FOR EXACT INVERT LOCATIONS) NOTIFY ENGINEER OF ANY DISCREPANCIES BEFORE INSTALLATION IS BEGUN
- NOTE: ALL WATER AND SEWER CONSTRUCTION SHALL BE IN ACCORDANCE WITH THE CITY OF BLOOMINGTON UTILITY SPECIFICATIONS.
- NOTE: ALL INVERT ELEVATIONS PROVIDED DIRECTLY OUTSIDE THE BUILDINGS WERE GIVEN BY THE PLUMBING ENGINEER, CONTRACTOR SHALL COORDINATE WITH 'P' SERIES DRAWINGS FOR FINAL EXISTING BUILDING UTILITY INVERT ELEVATIONS
- NOTE: CONTRACTOR TO USE A STEEL SLEEVE WHEN IT IS SHOWN TO ROUTE PIPING THROUGH WALL, COORDINATE WITH STRUCTURAL AND ARCHITECTURAL DRAWINGS

IMPERVIOUS AREA

TOTAL SITE AREA = 48,866 S.F.
 TOTAL SITE IMPERVIOUS AREA = 29,229 S.F.
 PERCENT IMPERVIOUS = 59.8% IMPERVIOUS

GENERAL LEGEND

- PROPERTY LINE
- PROPERTY LINE
- xxx/xxx DEED BOOK AND PAGE
- T.B.R. TO BE REMOVED
- T.R.U. TO REMAIN UNDISTURBED
- X' SBL SETBACK LINE
- (Wheelchair icon) PROPOSED ACCESSIBLE PARKING SPACE
- S.S.E. SANITARY SEWER EASEMENT
- G.E. GAS EASEMENT
- W.L.E. WATER LINE EASEMENT
- E.E. ELECTRIC EASEMENT
- D.E. DRAINAGE EASEMENT
- U.E. UTILITY EASEMENT

NOTE TO CONTRACTOR

CONTRACTOR SHALL VERIFY ALL UTILITY LOCATIONS & DEPTHS AND NOTIFY ENGINEER OF ANY INACCURACIES IN LOCATION OR ELEVATION OR ANY CONFLICTS PRIOR TO & AFTER ANY EXCAVATION. NO PAYMENT SHALL BE MADE TO CONTRACTOR FOR UTILITY DESTRUCTION OR UNDERGROUND CHANGES REQUIRED DUE TO CONFLICTING ELEVATIONS.

revisions:

BBB
 BYNUM FANYO & ASSOCIATES, INC.
 ARCHITECTURE
 CIVIL ENGINEERING
 PLANNING
 Bloomington, Indiana
 (812) 332-2990 (Fax)
 528 north walnut street
 (812) 332-8030

certified by:

**PROPOSED
 CREW GARWASH**
 2901 E. 3RD STREET
 BLOOMINGTON, IN 47401

title: SITE & UTILITY PLAN

designed by: AJW
 drawn by: AJW
 checked by: DJB
 sheet no: C301
 project no.: 402256

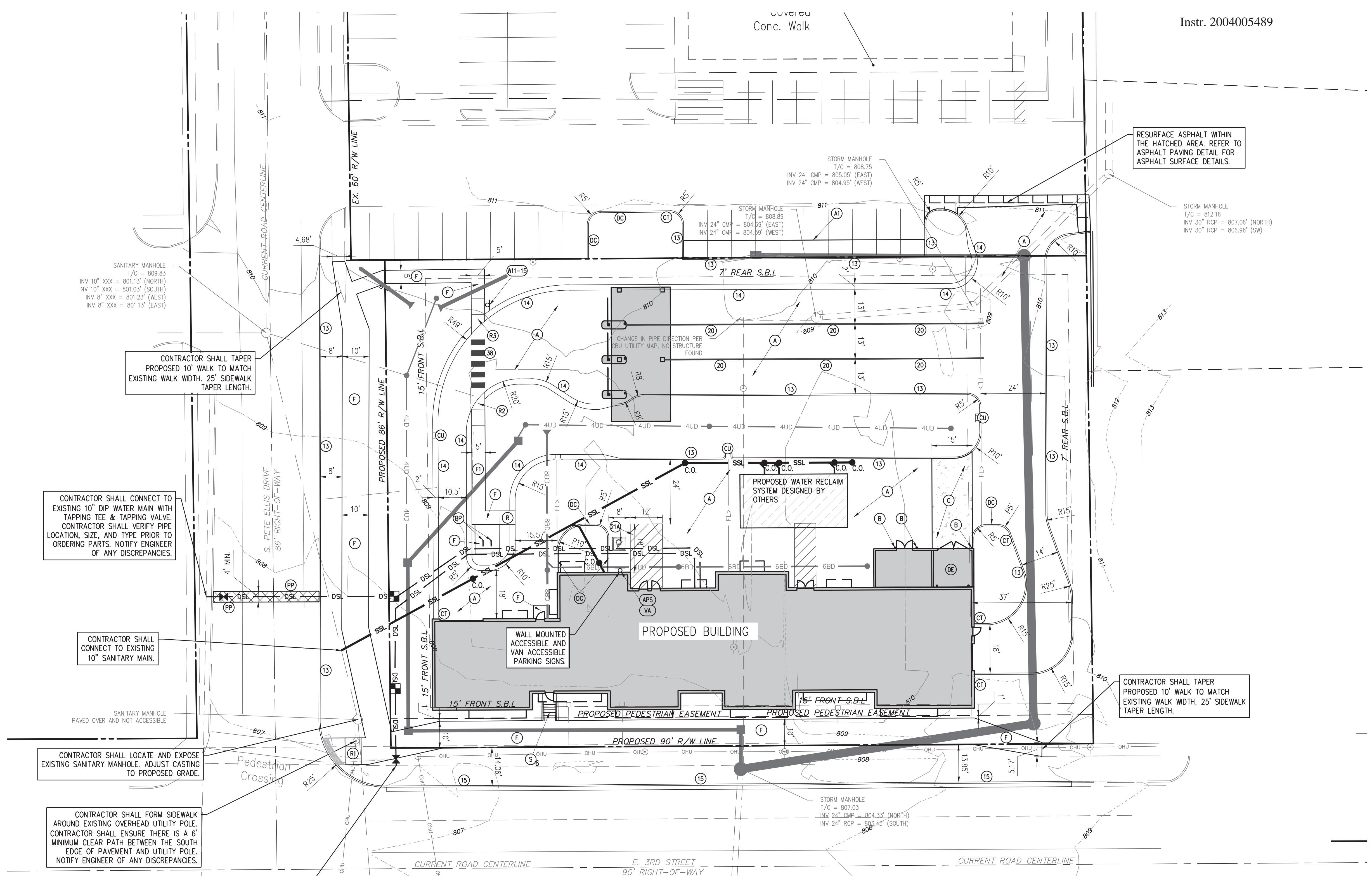

CONTRACTOR SHALL TAPER PROPOSED 10' WALK TO MATCH EXISTING WALK WIDTH. 25' SIDEWALK TAPER LENGTH.

CONTRACTOR SHALL CONNECT TO EXISTING 10" DIP WATER MAIN WITH TAPPING TEE & TAPPING VALVE. CONTRACTOR SHALL VERIFY PIPE LOCATION, SIZE, AND TYPE PRIOR TO ORDERING PARTS. NOTIFY ENGINEER OF ANY DISCREPANCIES.

CONTRACTOR SHALL CONNECT TO EXISTING 10" SANITARY MAIN.

CONTRACTOR SHALL LOCATE AND EXPOSE EXISTING SANITARY MANHOLE. ADJUST CASTING TO PROPOSED GRADE.

CONTRACTOR SHALL FORM SIDEWALK AROUND EXISTING OVERHEAD UTILITY POLE. CONTRACTOR SHALL ENSURE THERE IS A 6' MINIMUM CLEAR PATH BETWEEN THE SOUTH EDGE OF PAVEMENT AND UTILITY POLE. NOTIFY ENGINEER OF ANY DISCREPANCIES.

CONTRACTOR SHALL CONNECT TO EXISTING 2" WATER LINE WITH TAPPING TEE & TAPPING VALVE. CONTRACTOR SHALL VERIFY LINE TYPE, LOCATION, AND SIZE PRIOR TO ORDERING PARTS. NOTIFY ENGINEER OF ANY DISCREPANCIES.

RESURFACE ASPHALT WITHIN THE HATCHED AREA. REFER TO ASPHALT PAVING DETAIL FOR ASPHALT SURFACE DETAILS.

CONTRACTOR SHALL TAPER PROPOSED 10' WALK TO MATCH EXISTING WALK WIDTH. 25' SIDEWALK TAPER LENGTH.

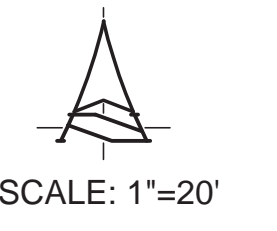

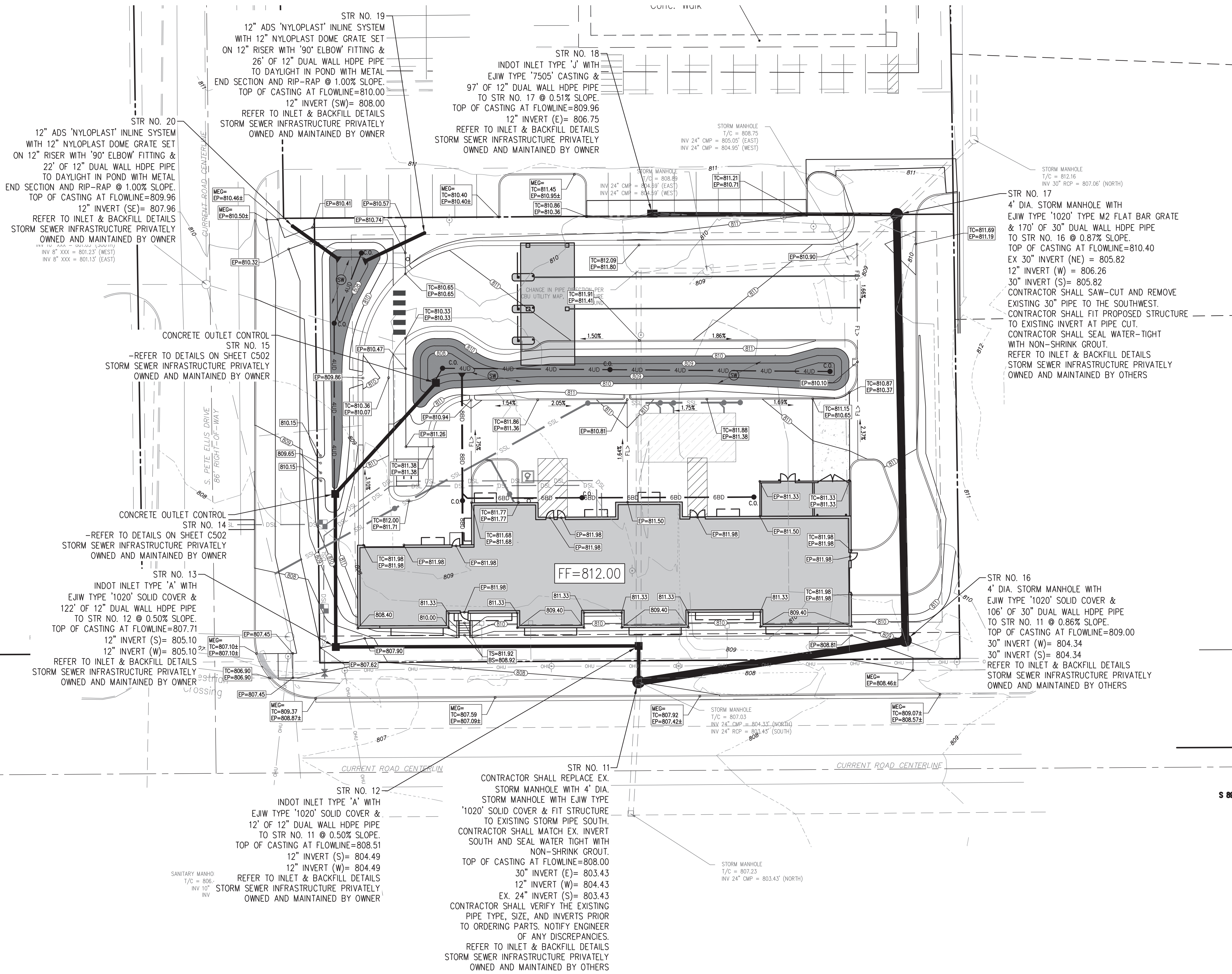

GENERAL LEGEND

---	PROPERTY LINE
---	PROPERTY LINE
XXX/XXX	DEED BOOK AND PAGE
T.B.R.	TO BE REMOVED
T.R.U.	TO REMAIN UNDISTURBED
X' SBL	SETBACK LINE
♿	PROPOSED ACCESSIBLE PARKING SPACE
S.S.E.	SANITARY SEWER EASEMENT
G.E.	GAS EASEMENT
W.L.E.	WATER LINE EASEMENT
E.E.	ELECTRIC EASEMENT
D.E.	DRAINAGE EASEMENT
U.E.	UTILITY EASEMENT

GRADING LEGEND

---	EXISTING CONTOUR	---	XXX
---	PROPOSED CONTOUR	---	XXX
---	PROPOSED INTENDED FLOWLINE DIRECTION	---	FL>
TW=XXX.XX	PROPOSED TOP OF WALL ELEVATION AT GRADE	TW=XXX.XX	PROPOSED TOP OF WALL ELEVATION AT GRADE
BW=XXX.XX	PROPOSED BOTTOM OF WALL ELEVATION AT GRADE	BW=XXX.XX	PROPOSED BOTTOM OF WALL ELEVATION AT GRADE
TC=XXX.XX	ACTUAL TOP OF WALL ELEVATION AND FINISH ELEVATION TO BE OBTAINED FROM ARCHITECTURAL AND STRUCTURAL DRAWINGS	TC=XXX.XX	ACTUAL TOP OF WALL ELEVATION AND FINISH ELEVATION TO BE OBTAINED FROM ARCHITECTURAL AND STRUCTURAL DRAWINGS
EP=XXX.XX	PROPOSED SPOT GRADE ELEVATION	EP=XXX.XX	PROPOSED SPOT GRADE ELEVATION
TC=XXX.XX	PROPOSED TOP OF CURB ELEVATION	TC=XXX.XX	PROPOSED TOP OF CURB ELEVATION
EP=XXX.XX	PROPOSED EDGE OF PAVEMENT ELEVATION AT BOTTOM OF CURB	EP=XXX.XX	PROPOSED EDGE OF PAVEMENT ELEVATION AT BOTTOM OF CURB
FF=XXX.XX	FINISH FLOOR ELEVATION	FF=XXX.XX	FINISH FLOOR ELEVATION
FX=XXX.XX	FINISH EDGE OF PAVEMENT AT GRADE	FX=XXX.XX	FINISH EDGE OF PAVEMENT AT GRADE
TS=XXX.XX	FINISH EDGE OF PAVEMENT/METAL STAIR AT TOP OF STEP(S) AT GRADE	TS=XXX.XX	FINISH EDGE OF PAVEMENT/METAL STAIR AT TOP OF STEP(S) AT GRADE
BS=XXX.XX	FINISH EDGE OF PAVEMENT/METAL STAIR AT BOTTOM OF STEP(S) AT GRADE	BS=XXX.XX	FINISH EDGE OF PAVEMENT/METAL STAIR AT BOTTOM OF STEP(S) AT GRADE
MEG=XXX.XX	MATCH THE EXISTING'S CONDITIONS GRADES ELEVATION FOR BEST FIT OF PROPOSED GRADING ADJACENT TO THE EXISTING CONDITION. NOTIFY THE ENGINEER OF ANY DISCREPANCIES	MEG=XXX.XX	MATCH THE EXISTING'S CONDITIONS GRADES ELEVATION FOR BEST FIT OF PROPOSED GRADING ADJACENT TO THE EXISTING CONDITION. NOTIFY THE ENGINEER OF ANY DISCREPANCIES
---	PROPOSED STORM PIPE AND INLET/MANHOLE, REFER TO PLAN FOR INLET DESIGN AND DETAILS FOR BACKFILL SPECIFICATIONS AND INLET/MANHOLE SPECIFICATIONS PER CBU STANDARDS	---	---
---	PROPOSED BUILDING DRAIN: 6" MIN SCHEDULE 40 PVC DRAIN PIPE TO POINT OF DISCHARGE AT STORM STRUCTURE OR DAYLIGHT IN POND WITH APPROPRIATE FITTINGS AND REDUCER FITTINGS WHEN SHOWN TO INCREASE FROM 4" TO 6" PIPE, 1.0% SLOPE MIN. WITH 24" COVER MIN. 6" MIN. DOWNSPOUT CONNECTIONS AND SCHEDULE 40 DOWNSPOUT BOOTHS ARE REQUIRED AT ALL DOWNSPOUT LOCATIONS. SHOP PRIME AND PAINT, COLOR PER ARCHITECT. REFER TO 'A' SERIES DRAWINGS FOR EXACT LOCATION OF ALL DOWNSPOUTS TO BE CONNECTED. NOTIFY ENGINEER OF ANY DISCREPANCIES. REFER ALSO TO THE STORM CLEAN-OUT DETAIL FOR ALL BUILDING DRAIN CLEAN-OUTS SHOWN.	---	---
---	PROPOSED DUAL WALL TYPE 'S' HDPE PERFORATED STORM PIPE UNDERDRAIN (NO SOCK) SLOPED AT 0.50% MIN. TO CONNECT TO STORM STRUCTURE. REFER TO PLAN FOR LOCATIONS AND STORM SEWER CLEAN-OUT. REFER TO UNDERDRAIN DETAIL FOR MORE INFORMATION AND STORM CLEAN-OUT DETAIL	---	---
---	STORMWATER QUALITY POND SOIL MIXTURE LIMITS: THIS IS FOR FILTRATION AND FOR GROWING GRASSES, SEDGES, PERENNIALS AND FORBS AS SPECIFIED ON THE LANDSCAPE PLAN. SEE DETAIL 'UD' ON SHEET C502 FOR DEPTH AND ADDITIONAL SPECIFICATIONS OF SOIL MIXTURE INCLUDING EXCLUSION OF SOIL MIXTURE OVER TOP OF UNDERDRAIN PIPING AS DETAILED	---	---

revisions:

ARCHITECTURE
CIVIL ENGINEERING
PLANNING

BYNUM FANYO & ASSOCIATES, INC.

52B north walnut street
(812) 332-8030

certified by:

**PROPOSED
CREW GARWASH**

2901 E. 3RD STREET
BLOOMINGTON, IN 47401

title: GRADING & DRAINAGE PLAN

designed by: AJW
drawn by: AJW
checked by: DJB
sheet no: C401
project no.: 402256

S 89°

SCALE: 1"=20'

NOTE TO CONTRACTOR

CONTRACTOR SHALL VERIFY ALL UTILITY LOCATIONS & DEPTHS AND NOTIFY ENGINEER OF ANY INACCURACIES IN LOCATION OR ELEVATION OR ANY CONFLICTS PRIOR TO & AFTER ANY EXCAVATION. NO PAYMENT SHALL BE MADE TO CONTRACTOR FOR UTILITY DESTRUCTION OR UNDERGROUND CHANGES REQUIRED DUE TO CONFLICTING ELEVATIONS.

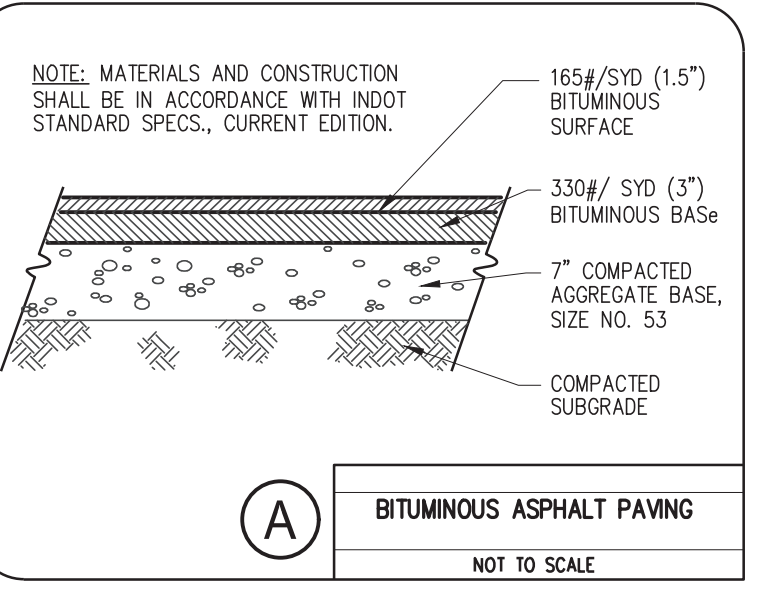
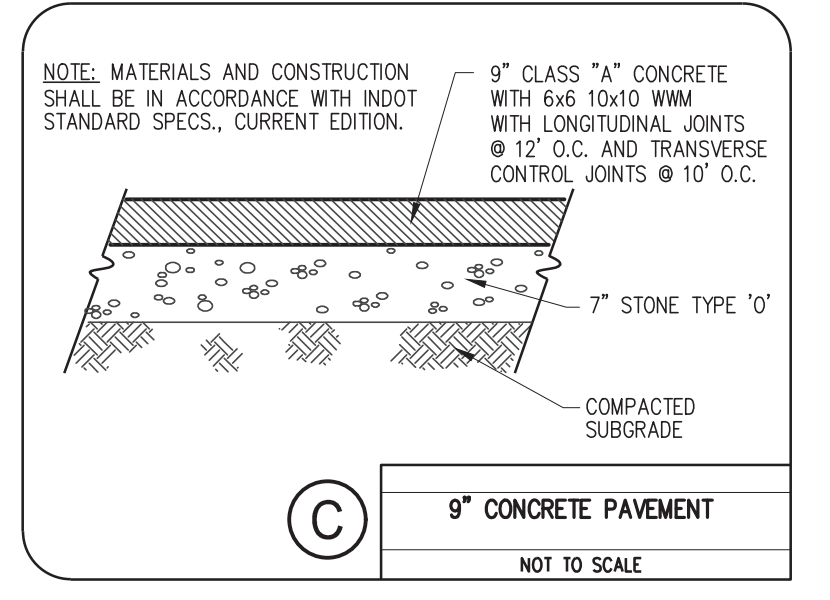
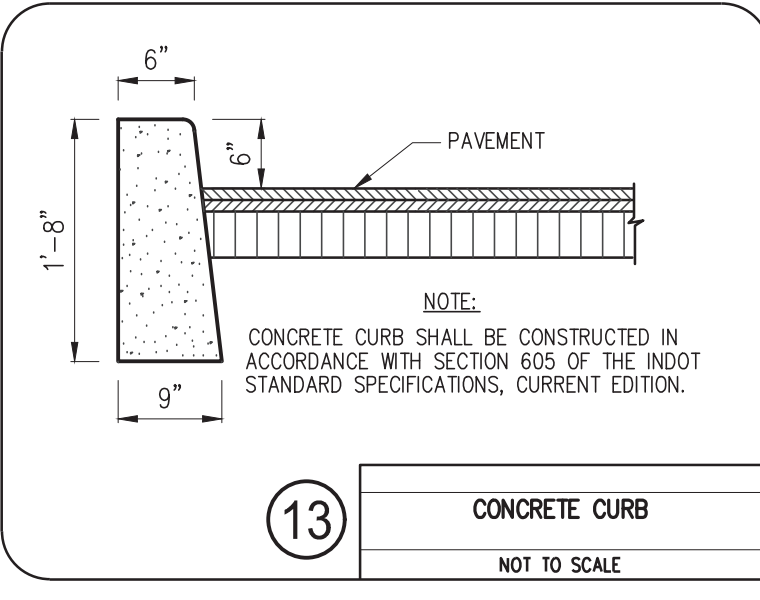
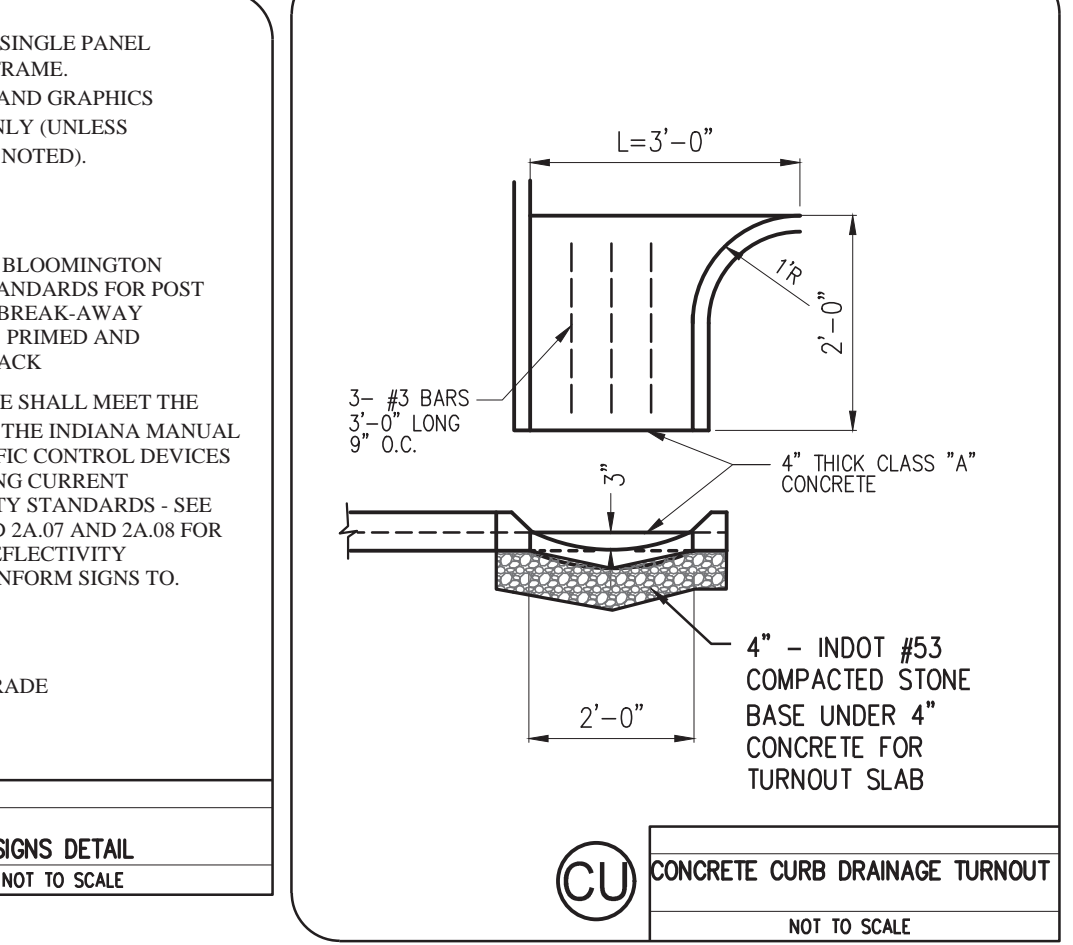
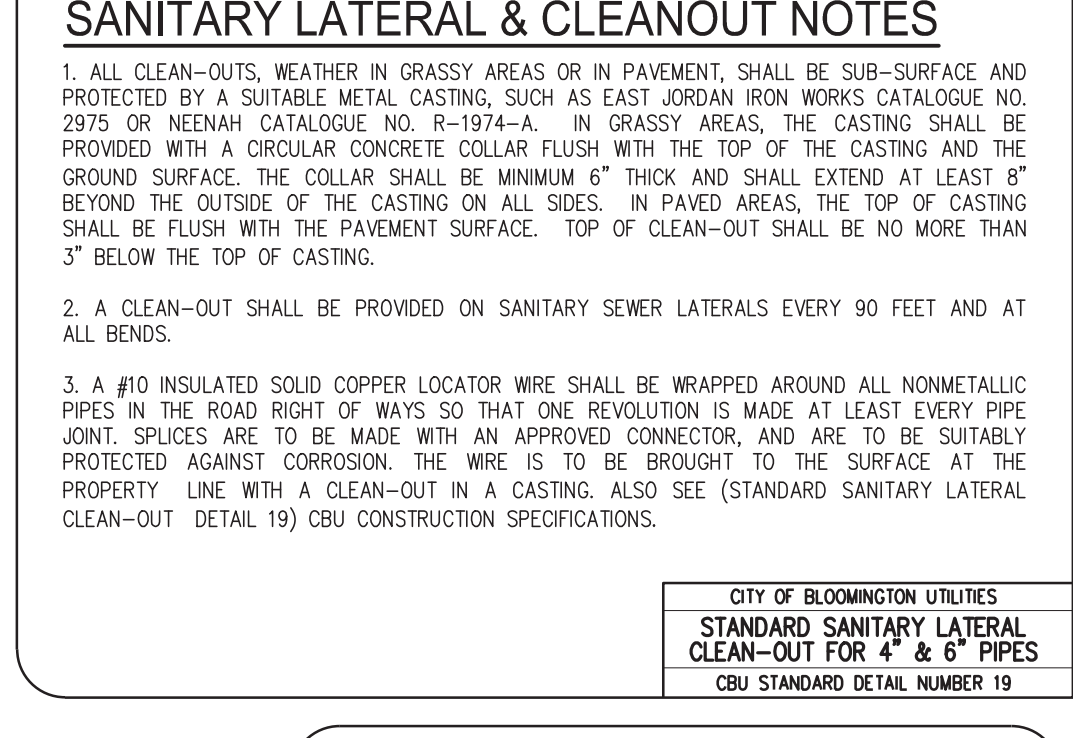
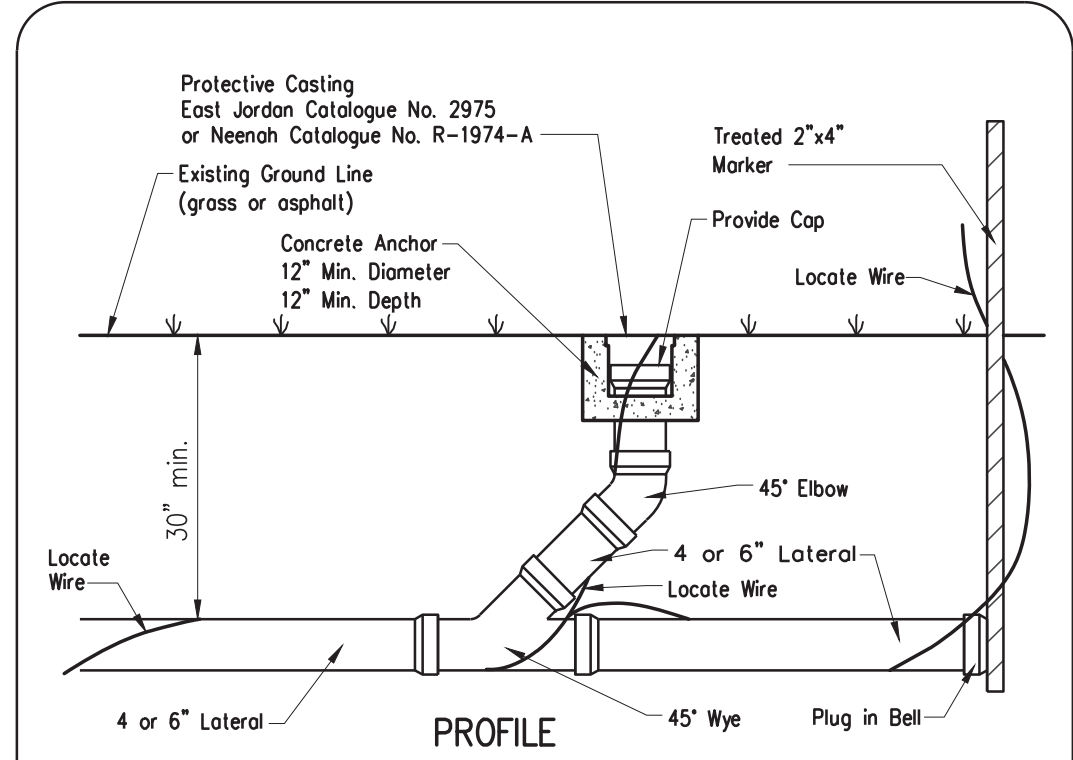
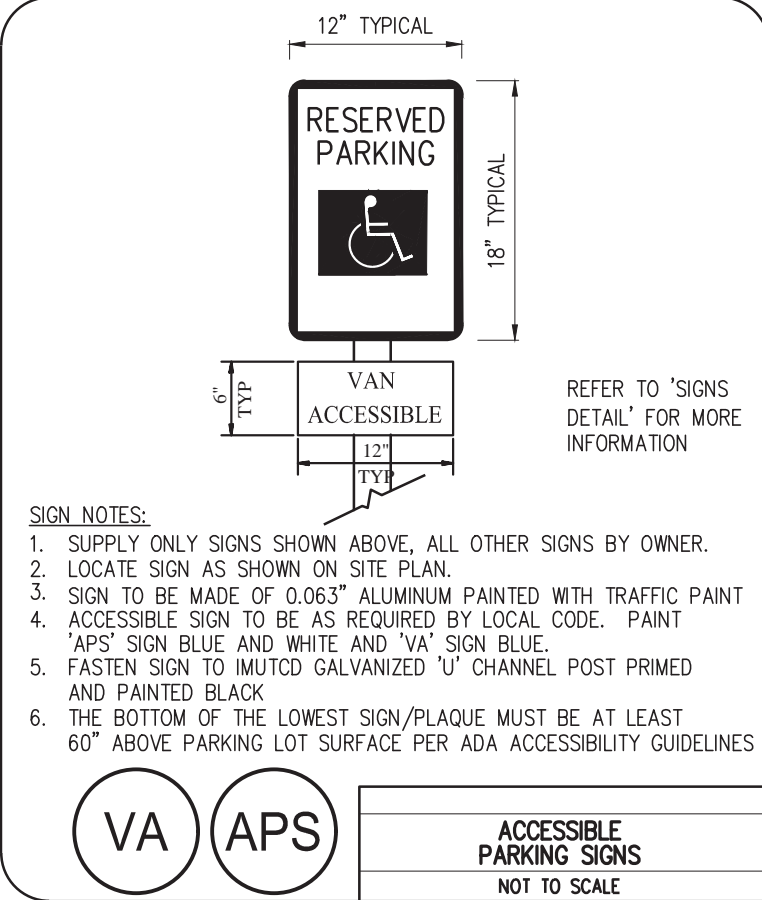
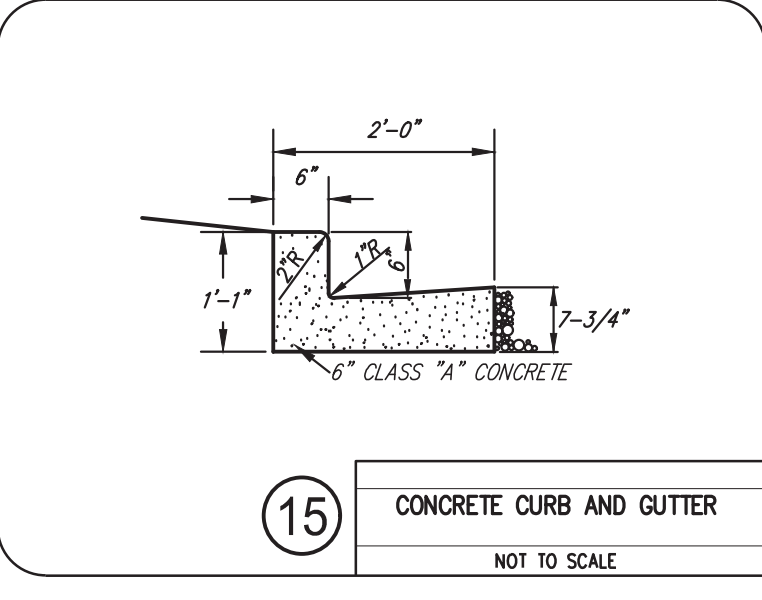
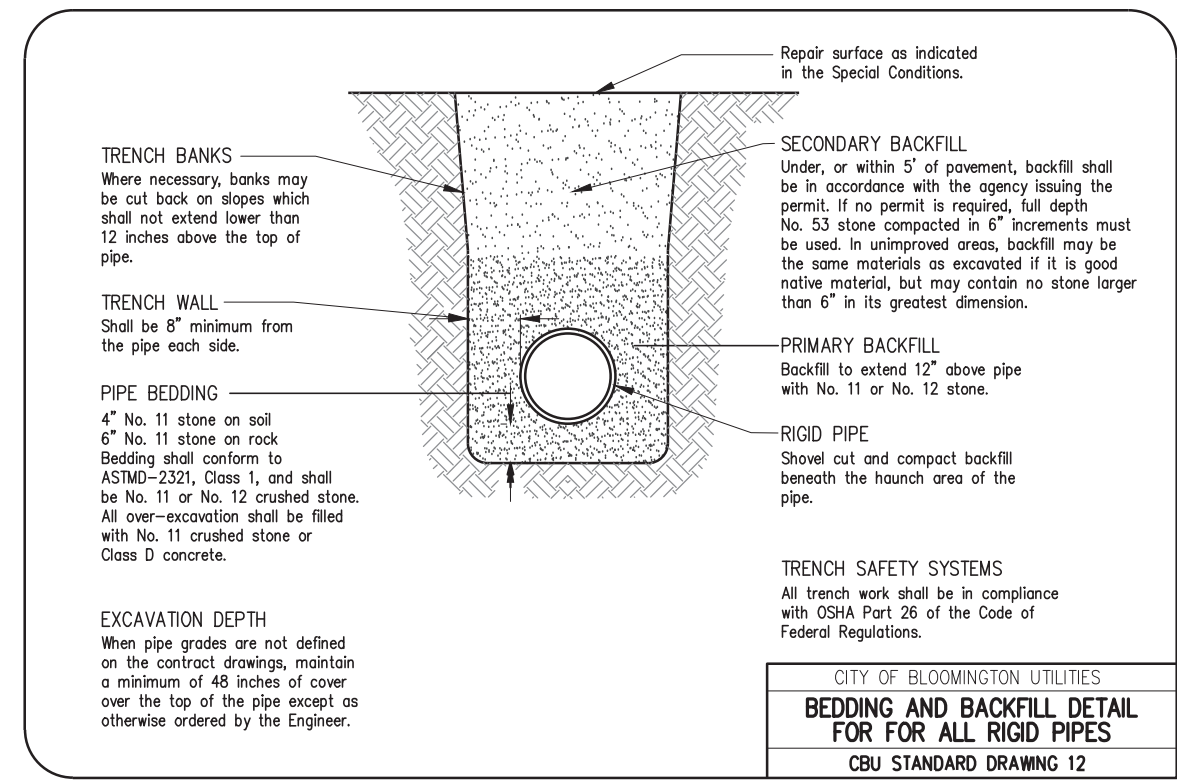
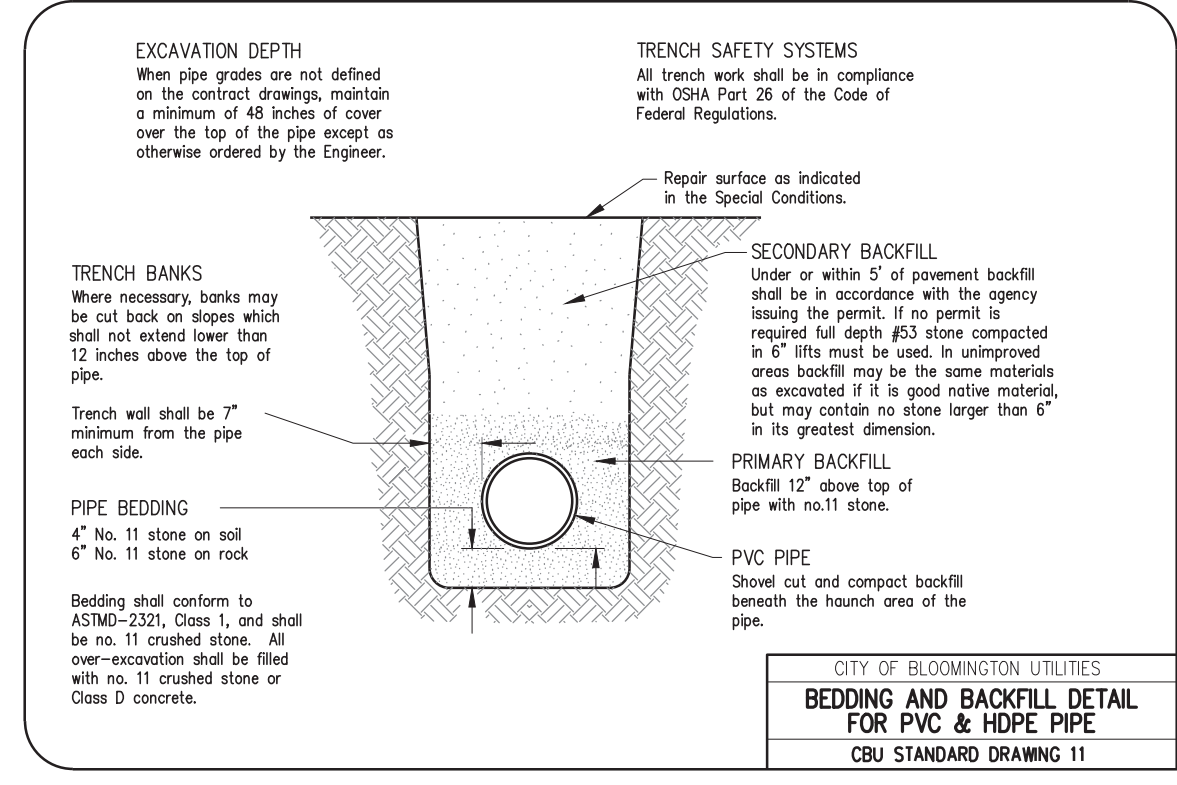

SHEET NO.	INDEX SUBJECT
1	Curb Ramp Drawing Index and General Notes
2-3	Perpendicular Curb Ramp Typical Placement
4	Perpendicular Curb Ramp Component Details
5	One-Way Directional Perpendicular Curb Ramp Typical Placement
6	One-Way Directional Perpendicular Curb Ramp Component Details
7	Parallel Curb Ramps Typical Placement
8	Parallel Curb Ramps Component Details
9	Blended Transition Curb Ramp, Degraded Curb Ramp and Diagonal Curb Ramp Typical Placement
10	Blended Transition Curb Ramp, Component Details
11	Median Curb Through and Median Perpendicular Curb Ramp Typical Placement
12-13	Detachable Warning Surface Placement and Configuration
14	Detachable Warning Surface Details

GENERAL NOTES:
1. All slopes are absolute rather than relative to the sidewalk or roadway grade. Slopes at least 0.50% less than the maximum are preferred.
2. Ramp or Blended Transition: A ramp or blended transition shall be used to lower or raise the sidewalk to connect with the street or highway.
3. Turning Space: A turning space shall be provided at the top of a perpendicular ramp, bottom of a parallel ramp, or where the pedestrian travel requires a change in direction. A common turning space may be shared by adjacent ramps. The turning space shall have a minimum clear dimension of 4 ft x 4 ft. Where the turning space is constrained at the back of the sidewalk by a curb, retaining wall, building, or feature over 2 inches in height, the maximum clear dimension shall be 4 ft x 5 ft, with the 5 ft dimension in the direction of the ramp running slope.
4. Flared Side: A flared side shall be used adjacent to a walkable surface. A flared side may be used adjacent to a non-walkable surface. A flared side shall have a maximum slope of 0.00% measured parallel to the back of the curb.
5. Return Curb: A return curb is placed perpendicular to the roadway curb. A return curb may be used adjacent to a non-walkable surface. A return curb shall not be used adjacent to a walkable surface. The return curb may be omitted where the non-walkable surface is flared and the curb adjacent the roadway is tapered to meet the flush curb at the bottom of the ramp.
6. Clear Space: A clear space shall be provided beyond the bottom grade break of a curb ramp wholly contained within the crosswalk and wholly outside the parallel vehicle travel path. The clear space shall have a minimum clear dimension of 4 ft x 4 ft.
7. Detachable Warning Surface: A detachable warning surface shall consist of truncated domes and be placed at each street, highway, or railroad crossing. The detachable warning surface shall extend a minimum of 2 ft in the direction of pedestrian travel and be placed the entire width of a ramp, blended transition, or turning space.
8. Running Slope: The running slope of a ramp, blended transition, or turning space shall be measured parallel to the direction of pedestrian travel.
a. A running slope of 2.00% or less is considered level.
b. A ramp shall have a maximum running slope of 8.33% but shall not require a ramp length to exceed 15 ft.
c. A blended transition shall have a maximum running slope of 5.00%.
d. A turning space shall have a maximum running slope of 2.00%.
9. Width: Unless otherwise noted, minimum width of a ramp, blended transition, or turning space, excluding flared sides or return curb, shall be 4 ft.
10. Grade Break: A grade break at the top and bottom of a ramp, blended transition, or turning space shall be perpendicular to the running slope. Grade breaks shall not be vertical. A grade break at the top and bottom of a ramp, blended transition, or turning space shall be perpendicular to the running slope. Grade breaks shall not be vertical. A grade break at the top and bottom of a ramp, blended transition, or turning space shall be perpendicular to the running slope. Grade breaks shall not be vertical.
11. Cross Slope Exceptions: The cross slope of a ramp, blended transition, or turning space shall be measured perpendicular to the direction of pedestrian travel.
a. The maximum cross slope at a pedestrian street crossing without yield or stop control shall be 5.00%.
b. The maximum cross slope at a pedestrian street crossing with yield or stop control shall be 2.00%.
c. The maximum cross slope at a roadway crossing shall be the established grade of the adjacent roadway.
12. Curb Slope: A counter slope is the cross slope of the gutter or street adjacent to the running slope of the ramp, blended transition, or turning space. See Standard Drawing E 604-SWCR-14 for counter slope details.
13. Objects such as a utility cover, vault frame, and grating shall be placed outside the curb.
14. Curb ramps shall be placed within the marked crosswalk area.
15. Drainage inlets should be located uphill from a curb ramp to prevent ponding in the path of pedestrian travel.

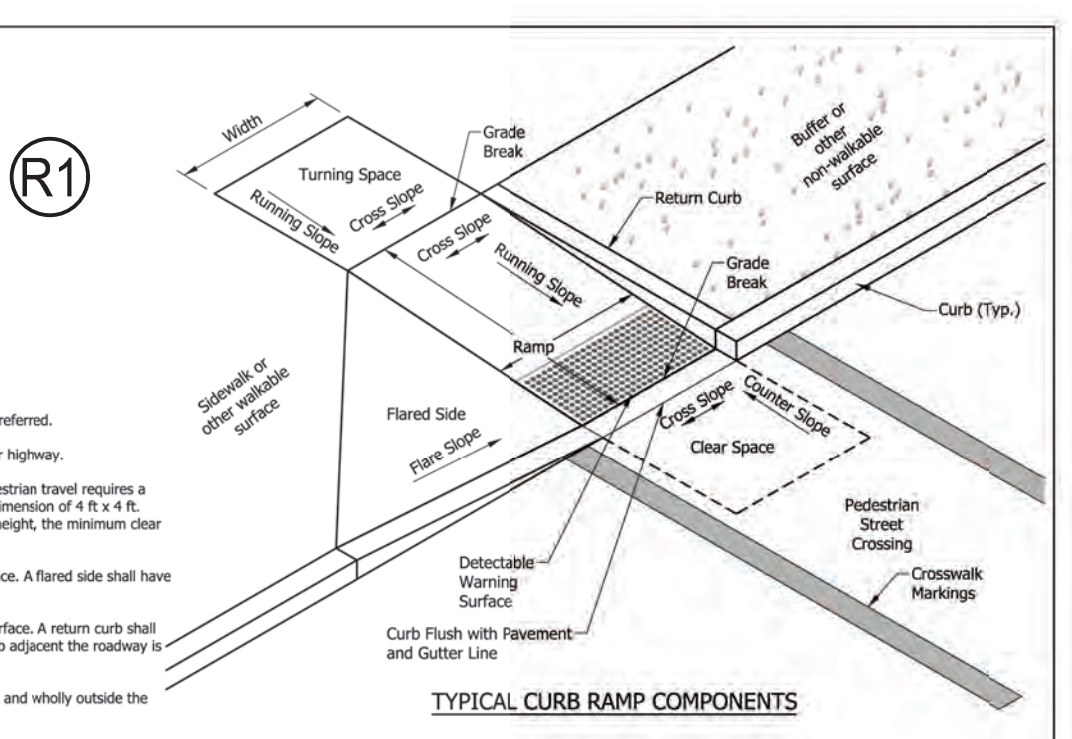

INDIANA DEPARTMENT OF TRANSPORTATION

CURB RAMP DRAWING INDEX AND GENERAL NOTES

SEPTEMBER 2018

STANDARD DRAWING NO. E 604-SWCR-01

10200124

1/ Elizabeth W. Phillips 03/29/18
DESIGN STANDARDS ENGINEER DATE

1/ John Leckie 04/25/18
CHIEF ENGINEER DATE

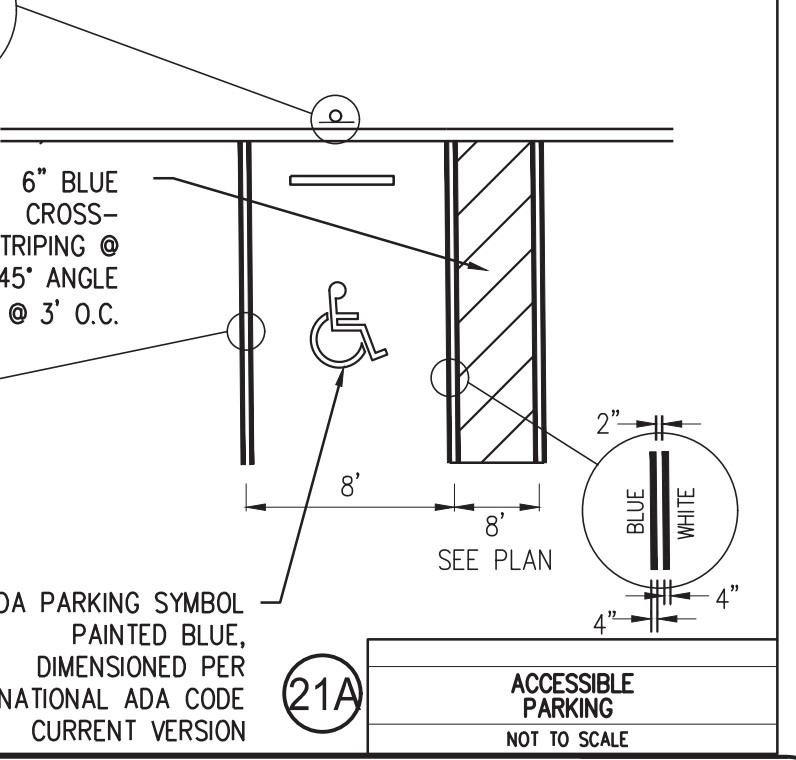
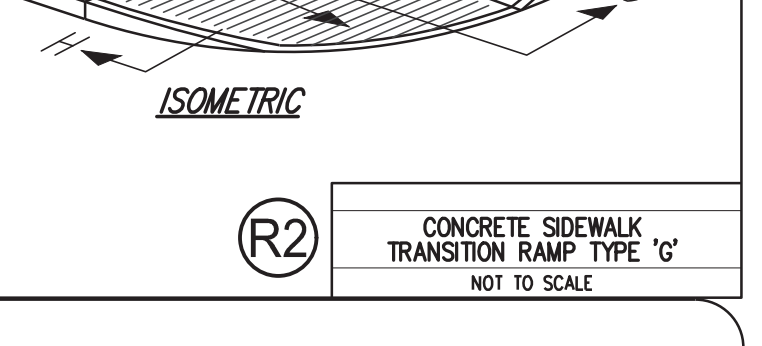
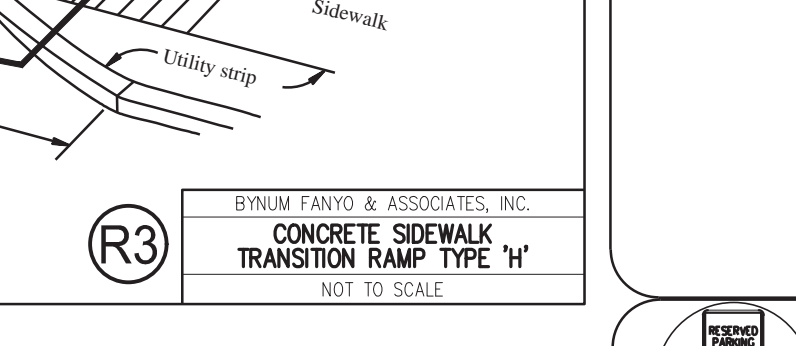
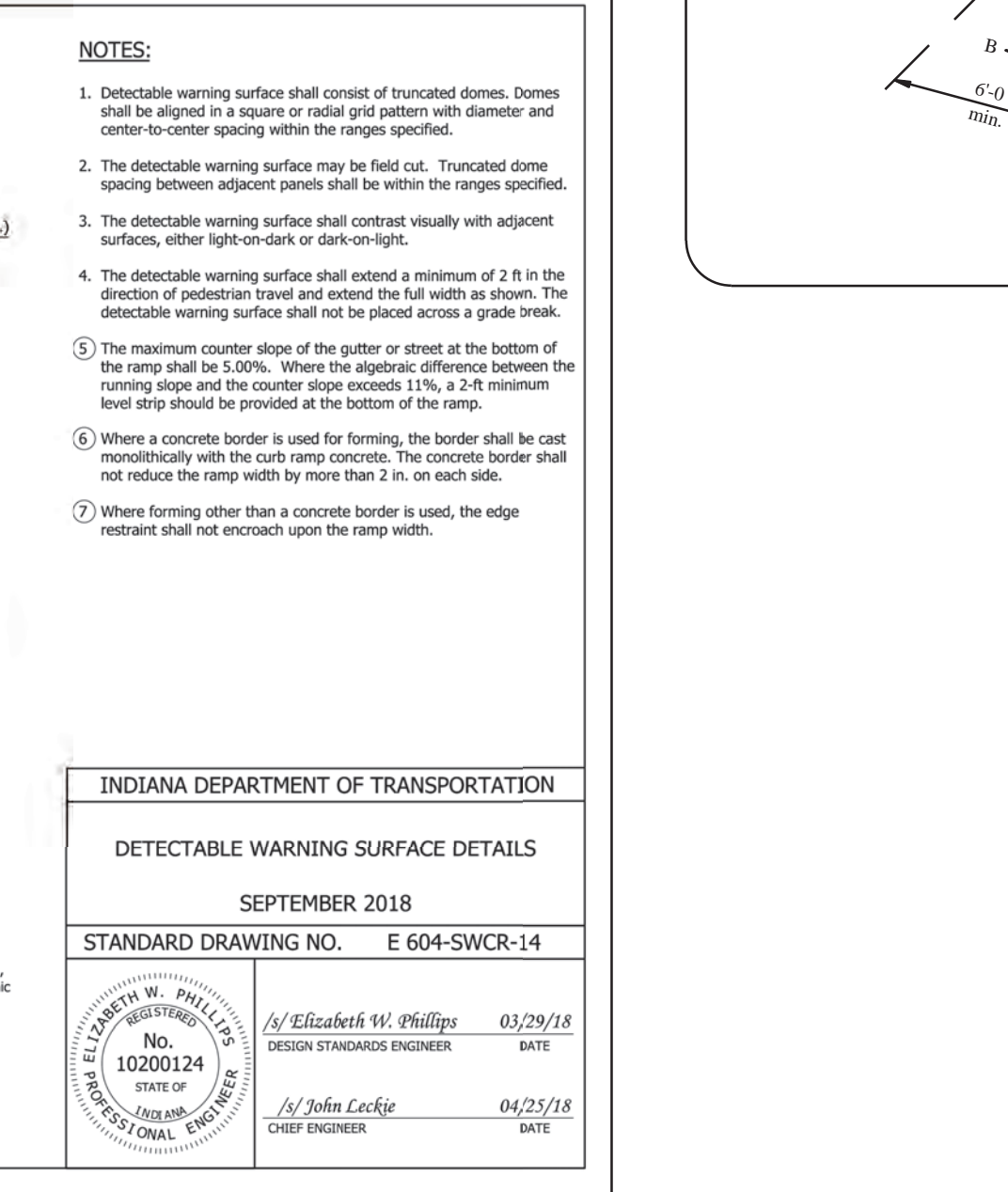
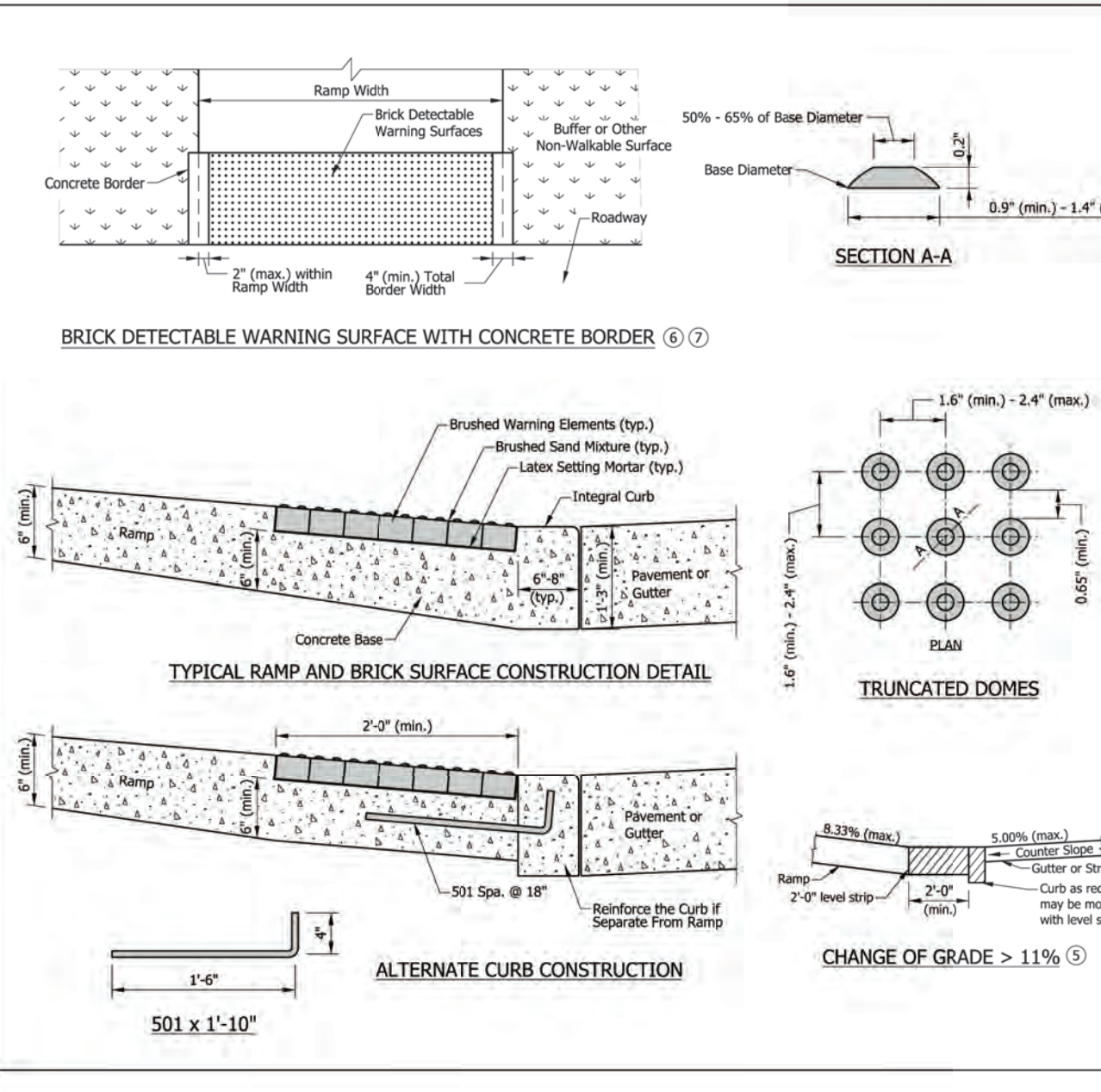
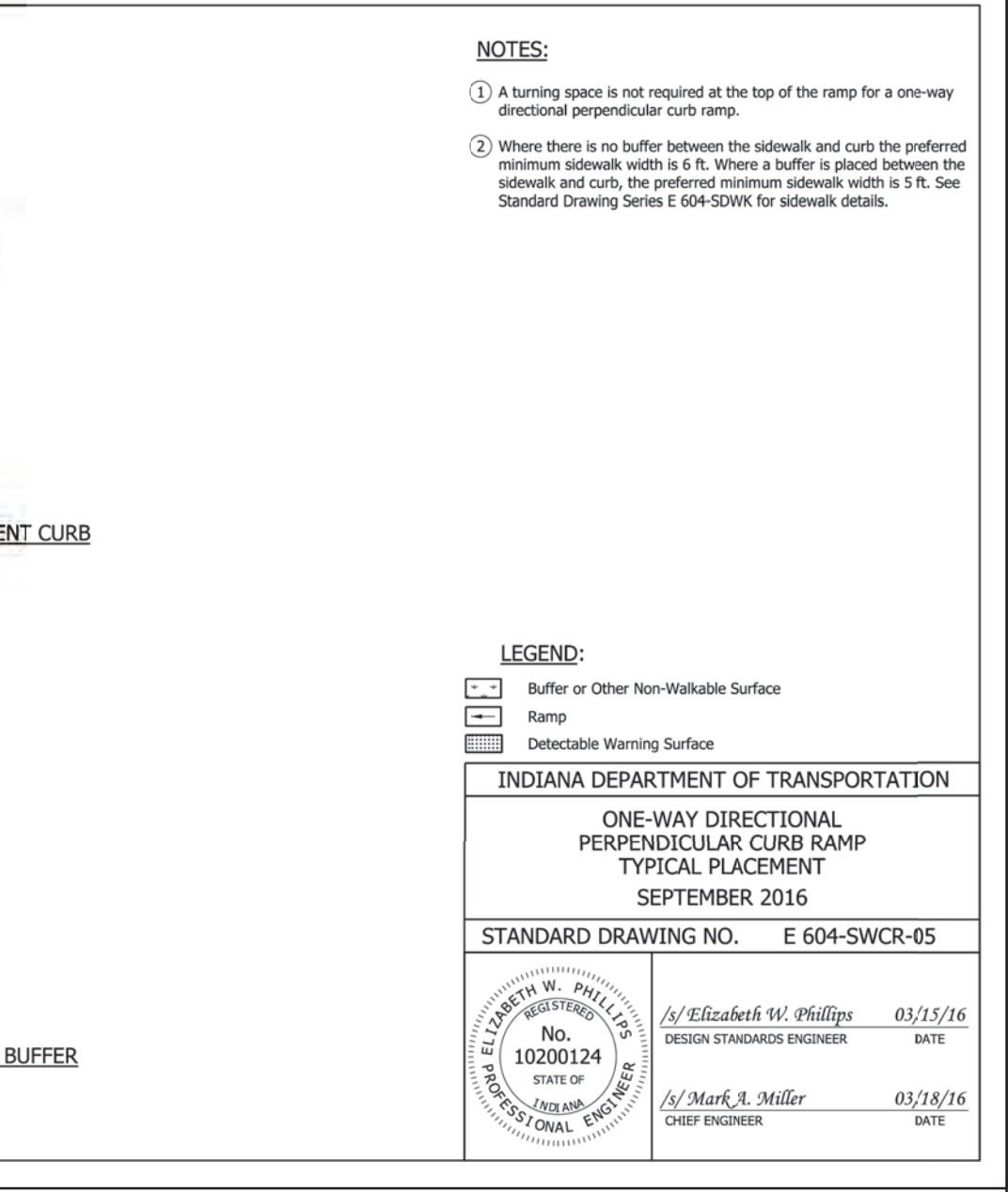
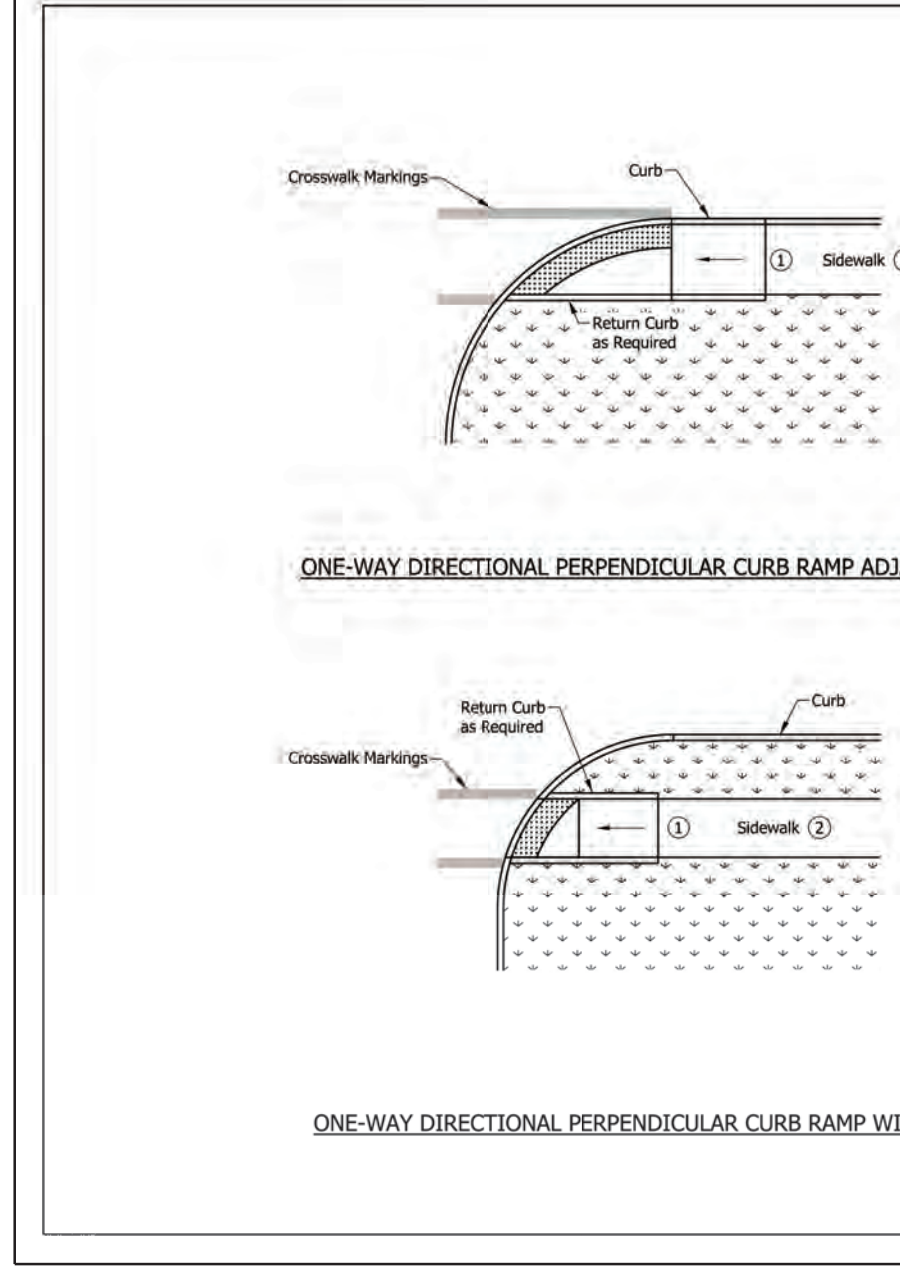

NOTE TO CONTRACTOR

CONTRACTOR SHALL VERIFY ALL UTILITY LOCATIONS & DEPTHS AND NOTIFY ENGINEER OF ANY INACCURACIES IN LOCATION OR ELEVATION OR ANY CONFLICTS PRIOR TO & AFTER ANY EXCAVATION. NO PAYMENT SHALL BE MADE TO CONTRACTOR FOR UTILITY DESTRUCTION OR UNDERGROUND CHANGES REQUIRED DUE TO CONFLICTING ELEVATIONS.

revisions:

ARCHITECTURE
CIVIL ENGINEERING
PLANNING

BYNUM FANYO & ASSOCIATES, INC.

Bloomington, Indiana
(812) 359-2990 (Fax)

52B north walnut street
(812) 332-8030

certified by:

PROPOSED CREW GARWASH

2901 E. 3RD STREET
BLOOMINGTON, IN 47401

title: MISCELLANEOUS DETAILS

designed by: AJW
drawn by: AJW
checked by: DJB
sheet no: C501
project no.: 402256

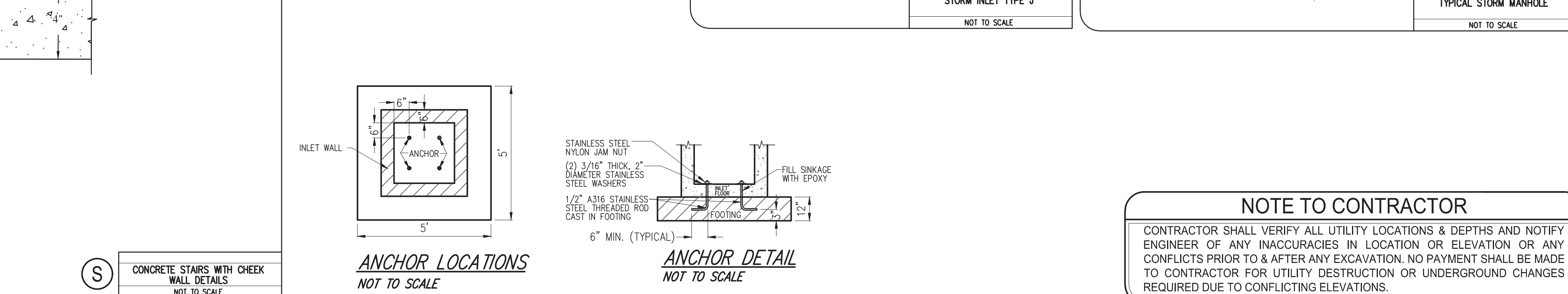
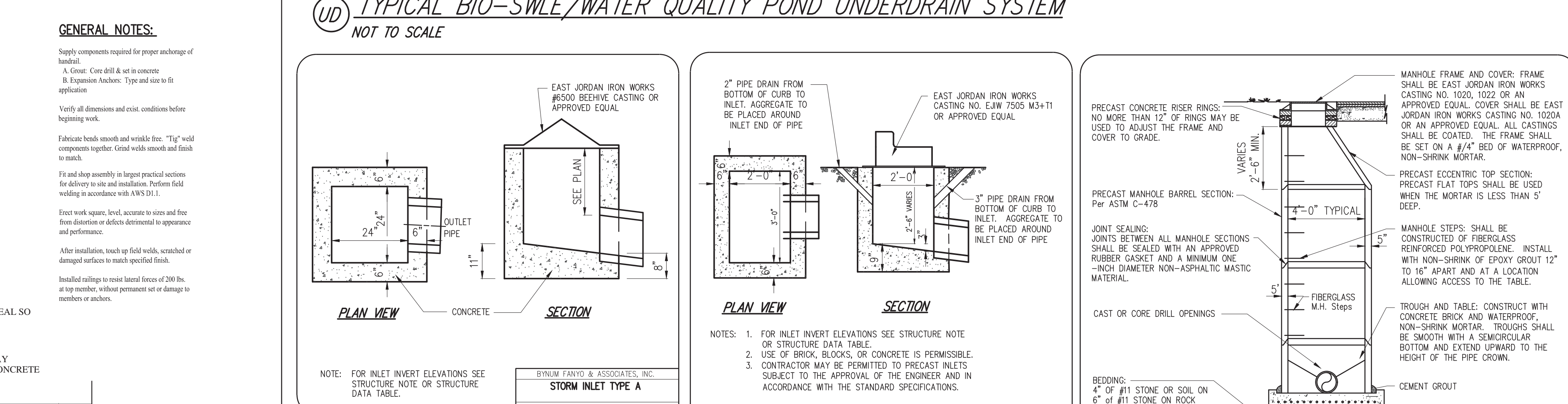
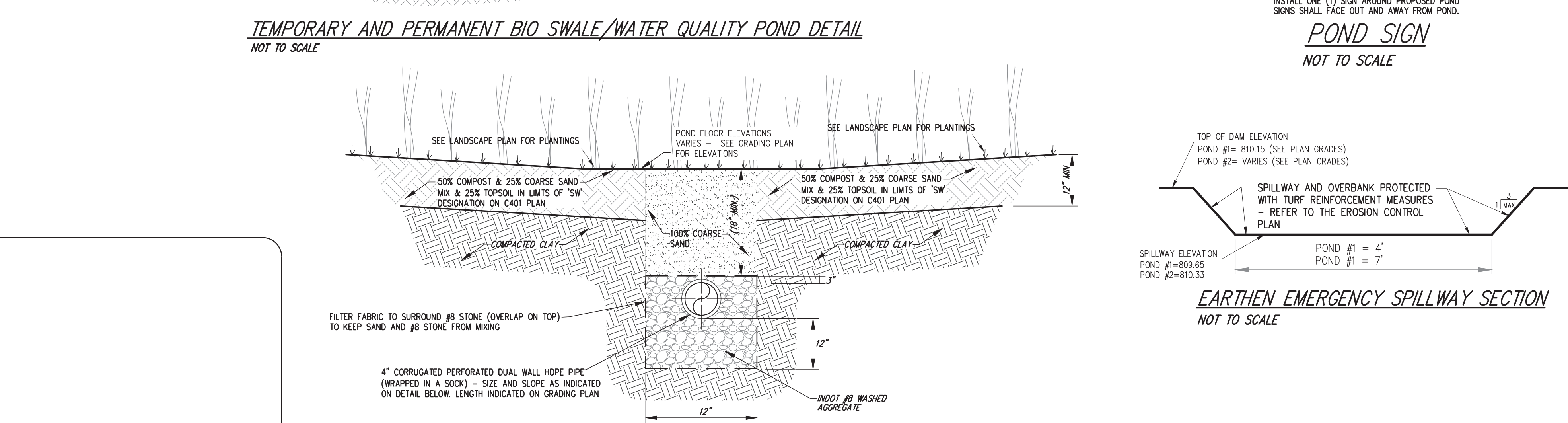
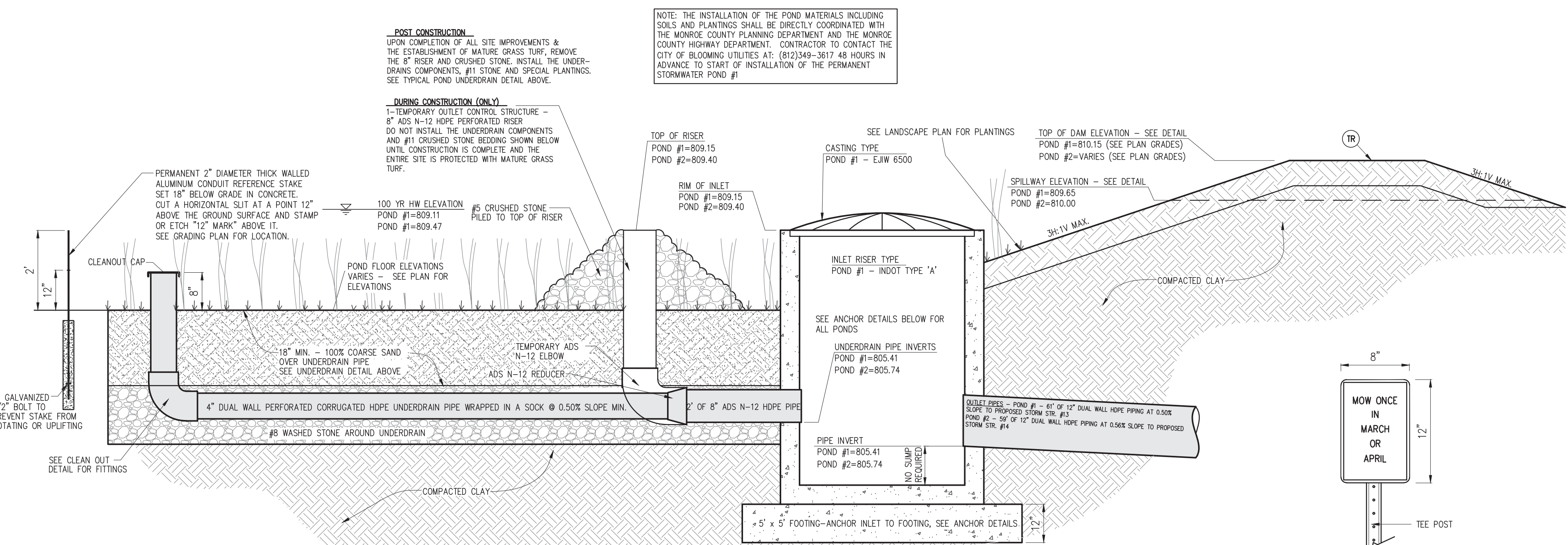
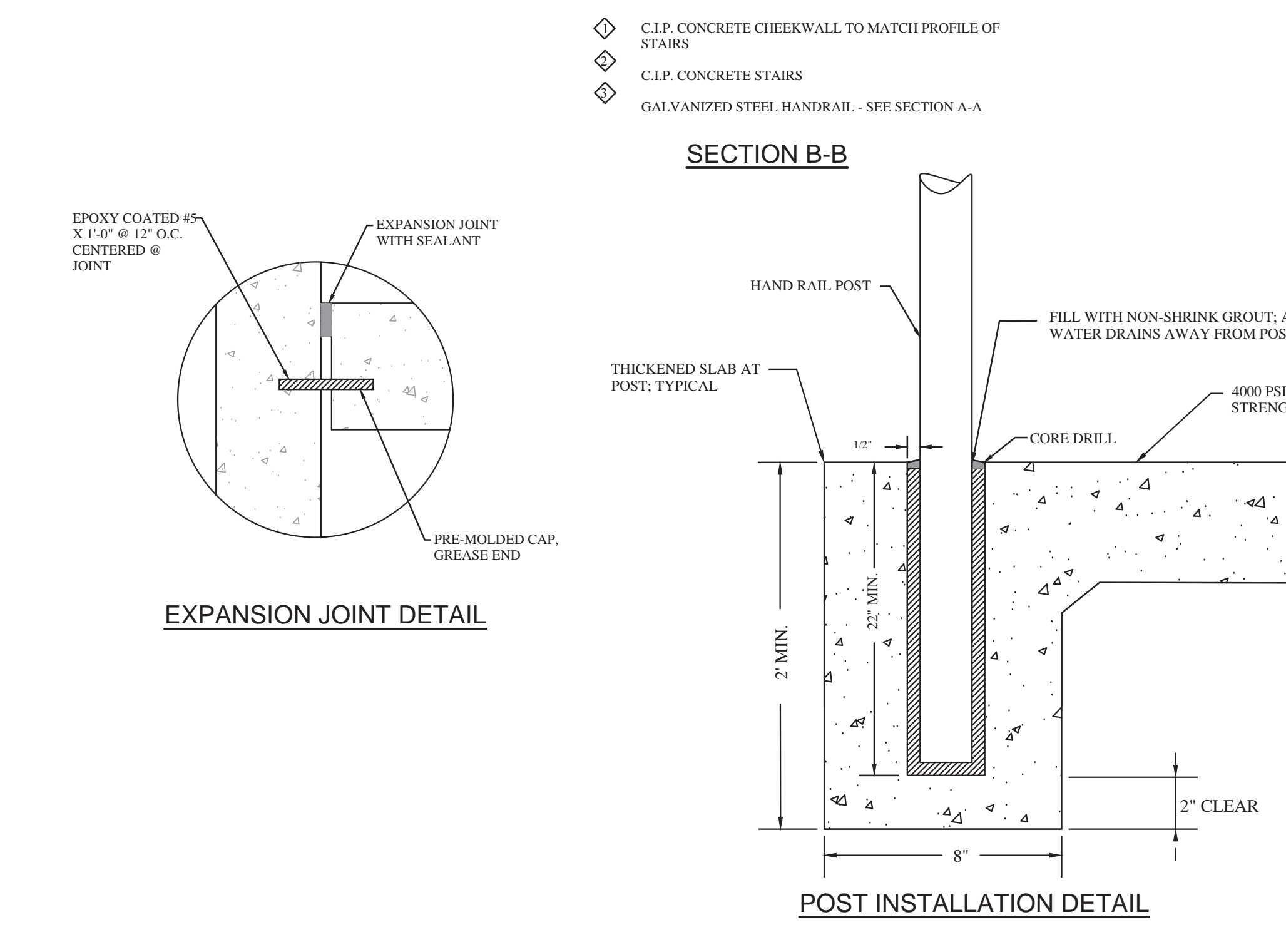
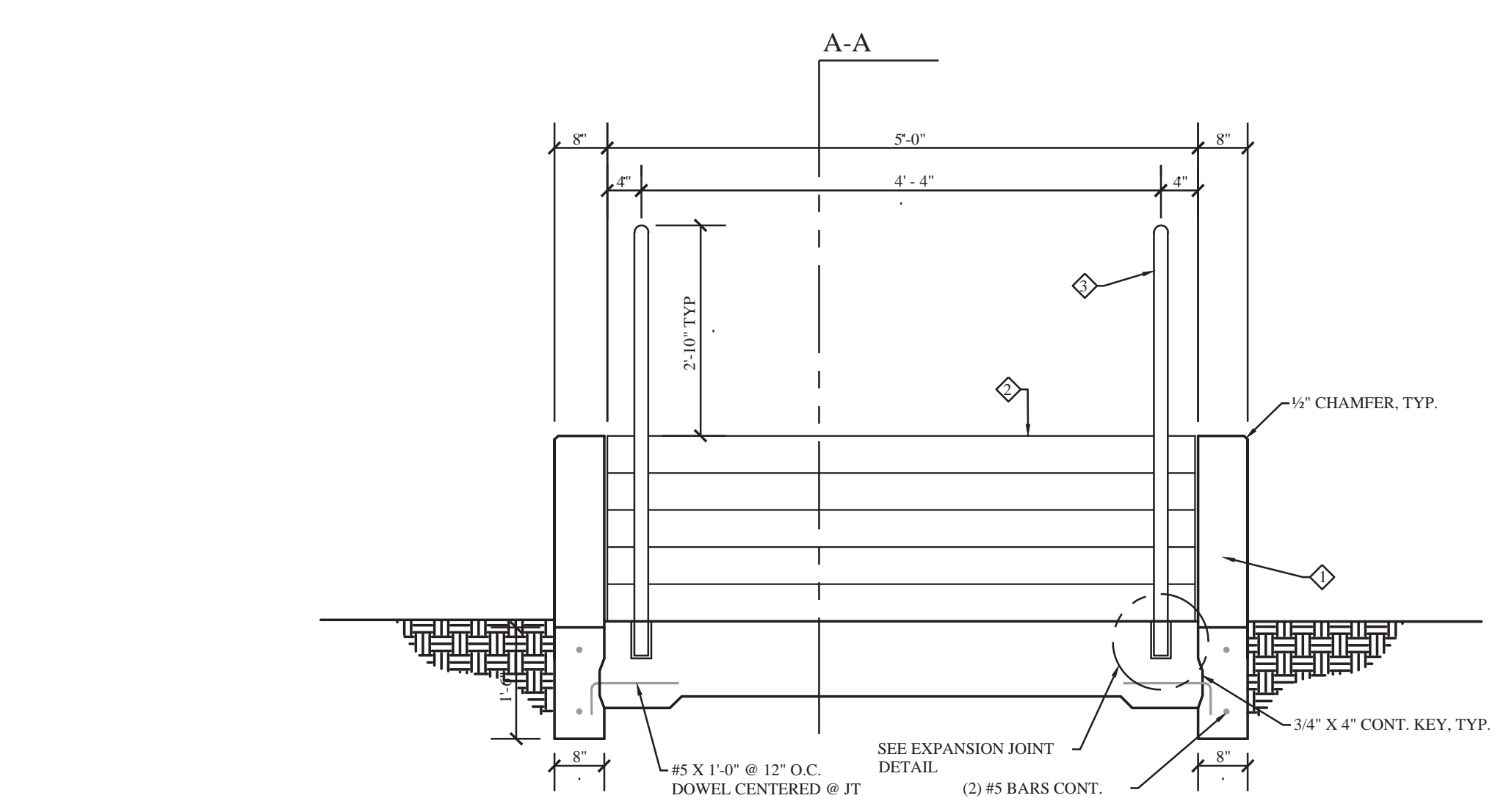
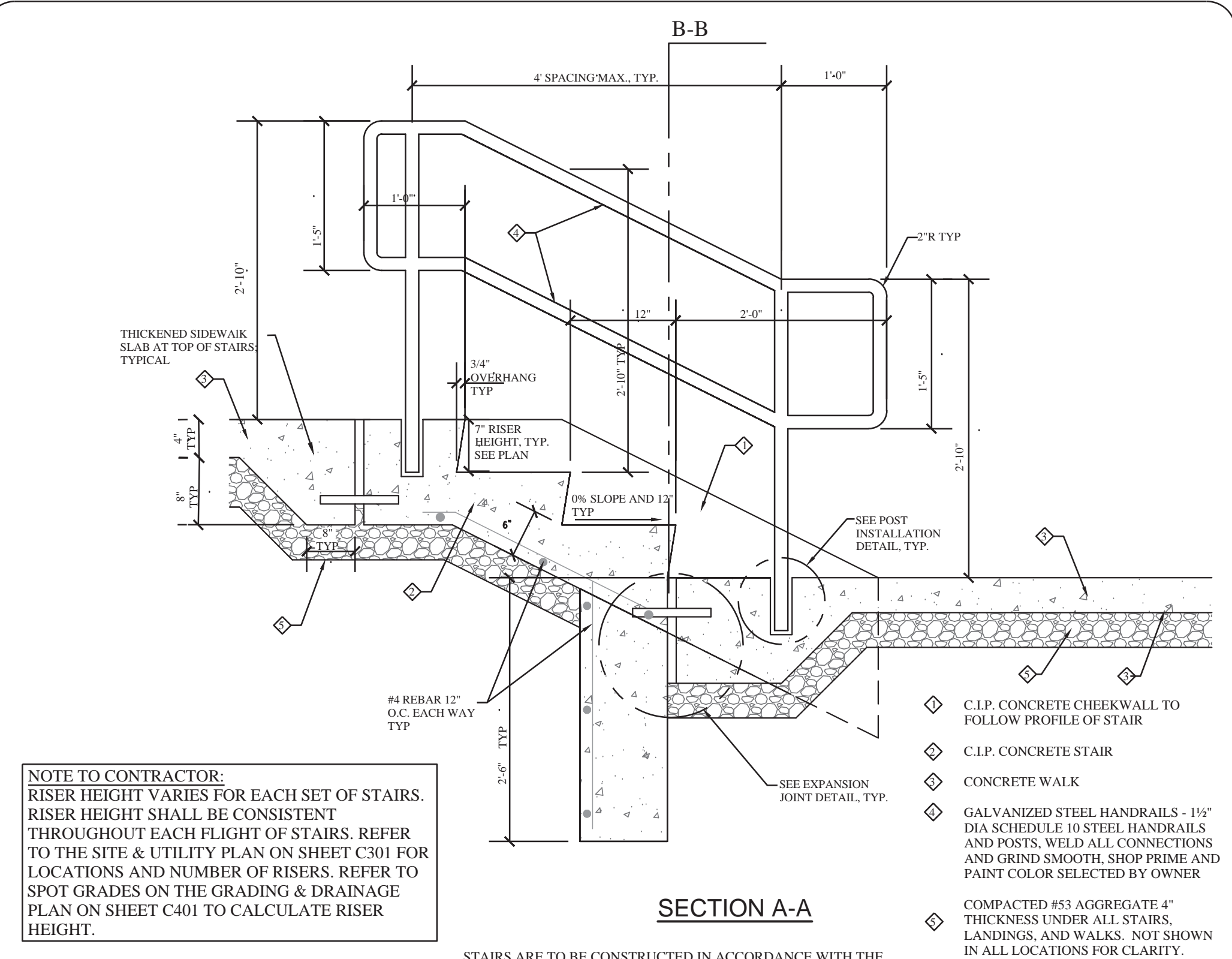

revisions:

ARCHITECTURE
CIVIL ENGINEERING
PLANNING

BYNUM FANYO & ASSOCIATES, INC.

Bloomingington, Indiana
(812) 359-2990 (Fax)

528 north walnut street
(812) 332-8030

certified by:

PROPOSED
CREW GARWASH
2901 E. 3RD STREET
BLOOMINGTON, IN 47401

title: DRAINAGE DETAILS

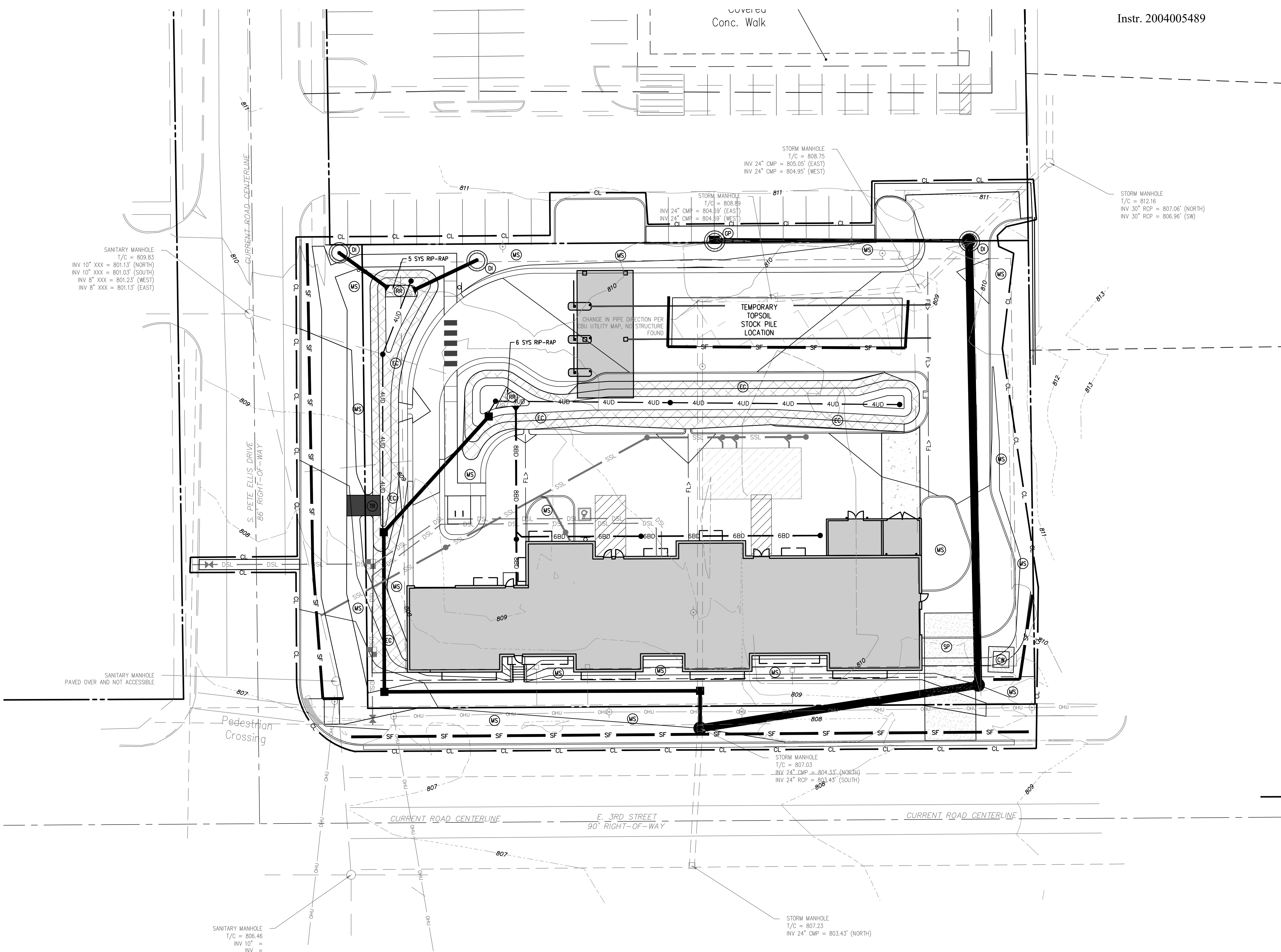

Instr. 2004005489

SANITARY MANHOLE
 T/C = 809.83
 INV 10" XXX = 801.13' (NORTH)
 INV 10" XXX = 801.03' (SOUTH)
 INV 8" XXX = 801.23' (WEST)
 INV 8" XXX = 801.13' (EAST)

Covered
 Conc. Walk

STORM MANHOLE
 T/C = 808.75
 INV 24" C.M.P. = 805.05' (EAST)
 INV 24" C.M.P. = 804.95' (WEST)

STORM MANHOLE
 T/C = 812.16
 INV 30" R.C.P. = 807.06' (NORTH)
 INV 30" R.C.P. = 806.96' (SW)

STORM MANHOLE
 T/C = 807.03
 INV 24" C.M.P. = 804.33' (NORTH)
 INV 24" R.C.P. = 804.45' (SOUTH)

STORM MANHOLE
 T/C = 807.23
 INV 24" C.M.P. = 803.43' (NORTH)

SANITARY MANHOLE
 T/C = 806.46
 INV 10" =
 INV =

GENERAL LEGEND

- — — — — PROPERTY LINE
- — — — — PROPERTY LINE
- XXX/XXX DEED BOOK AND PAGE
- T.B.R. TO BE REMOVED
- T.R.U. TO REMAIN UNDISTURBED
- X' SBL SETBACK LINE
- ♿ PROPOSED ACCESSIBLE PARKING SPACE
- S.S.E. SANITARY SEWER EASEMENT
- G.E. GAS EASEMENT
- W.L.E. WATER LINE EASEMENT
- E.E. ELECTRIC EASEMENT
- D.E. DRAINAGE EASEMENT
- U.E. UTILITY EASEMENT

EROSION CONTROL LEGEND

- SF — SILTATION FENCE (TEMPORARY)
- CL — CONSTRUCTION LIMITS
- MS MULCH SEEDING - SEE SPECIFICATIONS (TEMPORARY)
- SP 20' X 50' STONE PAD, 6" DEEP TO KEEP FROM TRACKING MUD OFF SITE (TEMPORARY)
- CW CONCRETE WASHOUT AREA (TEMPORARY)
- EC EROSION CONTROL BLANKET (PERMANENT)
- IR 'NORTH AMERICAN GREEN BRAND SERIES SC-250' TURF REINFORCEMENT MATTING - PERMANENT - APPLY TO POND EMERGENCY OVERFLOW AS INDICATED
- RR D-50 RIP-RAP STORM OUTLET PROTECTION - REFER TO DETAIL AND PLAN FOR MIN. QUANTITY (PERMANENT)
- DI GRAVEL DROP INLET PROTECTION (TEMPORARY) (TO BE USED ON ALL YARD INLETS)
- DD GRAVEL DONUT DROP INLET PROTECTION (TEMPORARY) - REFER TO DETAILS
- GP GRAVEL CURB INLET PROTECTION (TEMPORARY) (TO BE USED ON ALL CURB INLETS)

revisions:

ARCHITECTURE
 CIVIL ENGINEERING
 PLANNING

BFB
 BYNUM FANYO & ASSOCIATES, INC.
 528 north walnut street
 (812) 332-8030

bloomington, indiana
 (812) 339-2990 (Fax)

certified by:

11.21.23

**PROPOSED
 CREW GARWASH**

2901 E. 3RD STREET
 BLOOMINGTON, IN 47401

title: STORM WATER
 POLLUTION
 PREVENTION PLAN

designed by: AJW
 drawn by: AJW
 checked by: DJB
 sheet no.: C601
 project no.: 402256

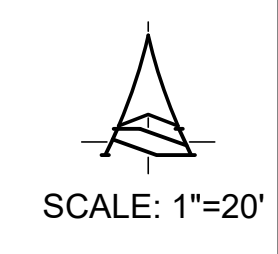

NOTE TO CONTRACTOR

CONTRACTOR SHALL VERIFY ALL UTILITY LOCATIONS & DEPTHS AND NOTIFY ENGINEER OF ANY INACCURACIES IN LOCATION OR ELEVATION OR ANY CONFLICTS PRIOR TO & AFTER ANY EXCAVATION. NO PAYMENT SHALL BE MADE TO CONTRACTOR FOR UTILITY DESTRUCTION OR UNDERGROUND CHANGES REQUIRED DUE TO CONFLICTING ELEVATIONS.

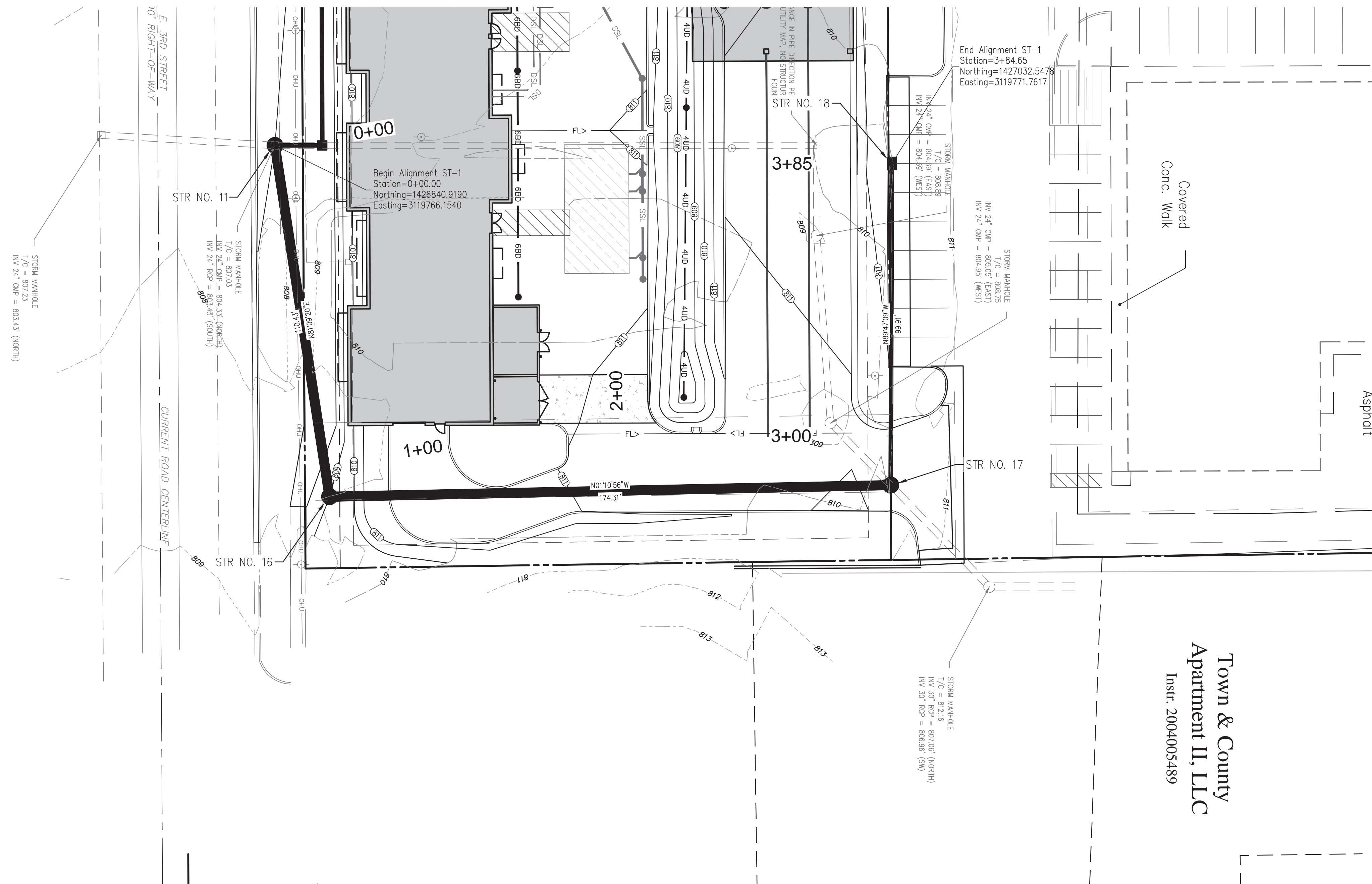

Town & County
Apartment II, LLC
Instr: 2004005489

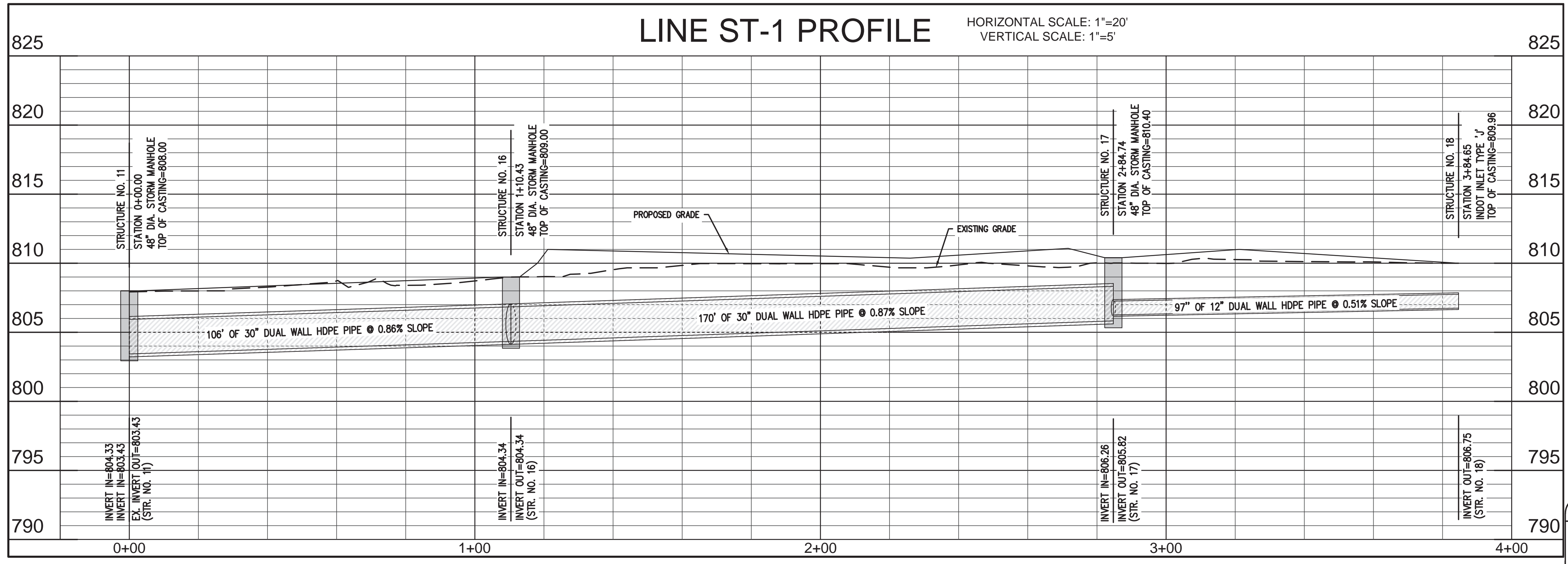
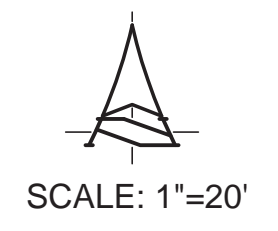

NOTE TO CONTRACTOR
CONTRACTOR SHALL VERIFY ALL UTILITY LOCATIONS & DEPTHS AND NOTIFY ENGINEER OF ANY INACCURACIES IN LOCATION OR ELEVATION OR ANY CONFLICTS PRIOR TO & AFTER ANY EXCAVATION. NO PAYMENT SHALL BE MADE TO CONTRACTOR FOR UTILITY DESTRUCTION OR UNDERGROUND CHANGES REQUIRED DUE TO CONFLICTING ELEVATIONS.

revisions:

ARCHITECTURE
CIVIL ENGINEERING
PLANNING

BYNUM FANYO & ASSOCIATES, INC.
52B north walnut street
(812) 332-8030

11.21.23

certified by:

**PROPOSED
CREW GARWASH**
2901 E. 3RD STREET
BLOOMINGTON, IN 47401

designed by: AJW
drawn by: AJW
checked by: DJB
sheet no: C701
project no.: 402256

title: ST-1 PLAN & PROFILE

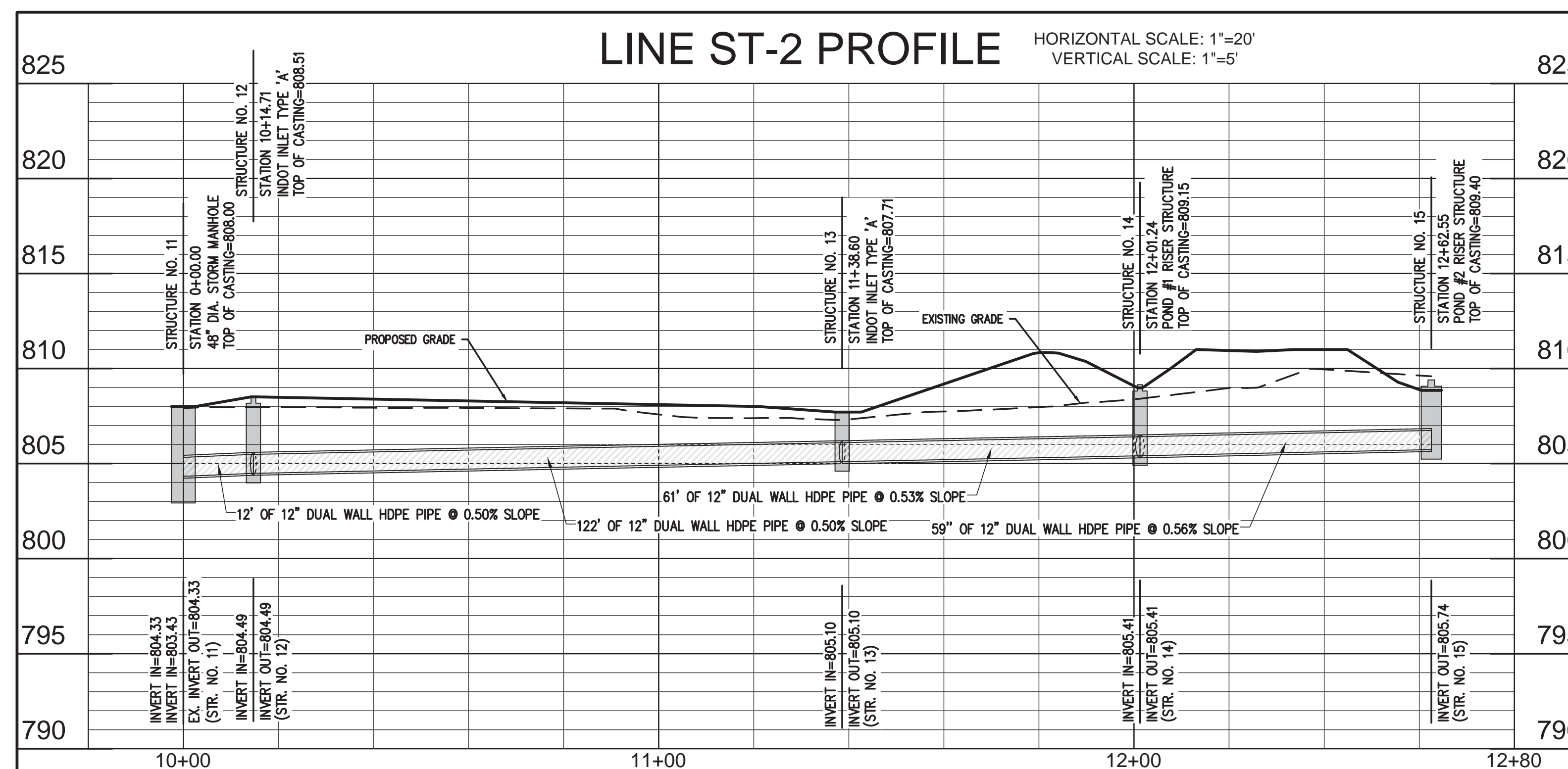
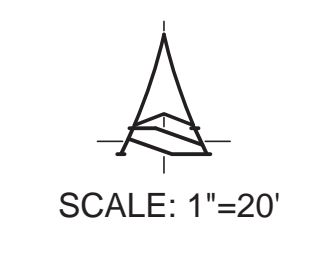
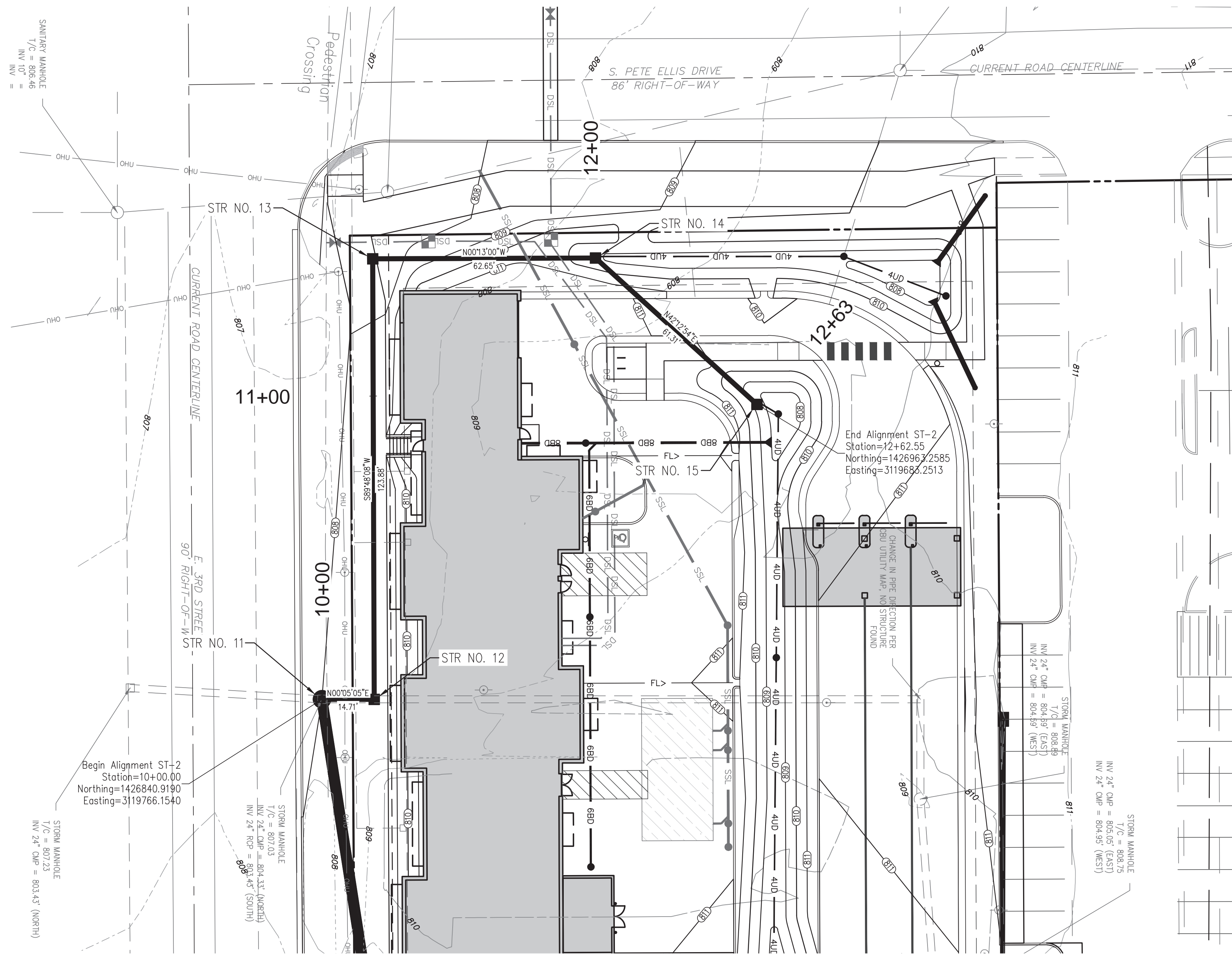

NOTE TO CONTRACTOR

CONTRACTOR SHALL VERIFY ALL UTILITY LOCATIONS & DEPTHS AND NOTIFY ENGINEER OF ANY INACCURACIES IN LOCATION OR ELEVATION OR ANY CONFLICTS PRIOR TO & AFTER ANY EXCAVATION. NO PAYMENT SHALL BE MADE TO CONTRACTOR FOR UTILITY DESTRUCTION OR UNDERGROUND CHANGES REQUIRED DUE TO CONFLICTING ELEVATIONS.

revisions:

BBB
BYNUM FANYO & ASSOCIATES, INC.
52B north walnut street
(812) 332-8030

ARCHITECTURE
CIVIL ENGINEERING
PLANNING

bloomington, indiana
(812) 339-2990 (Fax)

11.21.23

certified by:

**PROPOSED
CREW GARWASH**
2901 E. 3RD STREET
BLOOMINGTON, IN 47401

title: ST-2 PLAN & PROFILE

designed by: AJW
drawn by: AJW
checked by: DJB
sheet no: C702
project no.: 402256



Board of Public Works Staff Report

Project/Event: 2024 Morton Street Garage Elevator Replacement
Petitioner/Representative: PW Parking Services, Jess Goodman
Staff Representative: Jess Goodman
Date: 3.08.2024

Report:

Kone, INC Morton Street Garage Elevator Removal, and Replacement:
Kone will be removing and replacing the Morton Street elevator. This will also require a new build out of the shaft for the new cab. KONE's pricing is based on demolition/replacement of existing OTIS' Gen 2 MRL Elevator system, including entrances (frames/doors) and entrance sills, Work by Others (WBO) provided by Rubicon Construction, and KONE's complete new A.C. Gearless MRL Electric Traction elevator system.

We recommend using Kone INC for this project.

Total cost of contract = \$367,000.00

Project Funding Source: 101-26-260000-54510 (CRED Fund Line)

Recommend **Approval** **Denial by:** Jess Goodman

City of Bloomington Contract and Purchase Justification Form

Vendor: **KONE, INC**

Contract Amount: **\$367,000**

This form should be completed and attached to the contract documents and forwarded to the Legal Department Attorney assigned to your Department. Contracts will not be approved by the Controller if a completed form is not included with the contract documents.

PURCHASE INFORMATION

1. Check the box beside the procurement method used to initiate this procurement: (Attach a quote or bid tabulation if applicable)

<input type="checkbox"/> Request for Quote (RFQ)	<input type="checkbox"/> Request for Proposal (RFP)	<input checked="" type="checkbox"/> Sole Source	<input type="checkbox"/> Not Applicable (NA)
<input type="checkbox"/> Invitation to Bid (ITB)	<input type="checkbox"/> Request for Qualifications (RFQu)	<input type="checkbox"/> Emergency Purchase	

2. List the results of procurement process. Give further explanation where requested. Yes No

	Yes	No	
# of Submittals:			Was the lowest cost selected? (If no, please state below why it was not.) Yes No
Met city requirements?	<input checked="" type="checkbox"/>	<input type="checkbox"/>	Kone INC already has a contract for 2024 Service Maintenance for all City of Bloomington garages. Kone is also part of the OMNIA co-op program that the City of Bloomington is a part of. This will provide discounts and other services for the elevator installation.
Met item or need requirements?	<input checked="" type="checkbox"/>	<input type="checkbox"/>	
Was an evaluation team used?	<input type="checkbox"/>	<input checked="" type="checkbox"/>	
Was scoring grid used?	<input type="checkbox"/>	<input checked="" type="checkbox"/>	
Were vendor presentations requested?	<input type="checkbox"/>	<input checked="" type="checkbox"/>	

3. State why this vendor was selected to receive the award and contract:

Kone INC already has a contract for 2024 Service Maintenance for all City of Bloomington garages. Kone is also part of the OMNIA co-op program that the City of Bloomington is a part of. This will provide discounts and other services for the elevator installation.

Print/Type Name

Print/Type Title

Department

**AGREEMENT BETWEEN CITY OF BLOOMINGTON PUBLIC WORKS
DEPRATMENT AND KONE, INC. FOR THE
MORTON STREET PARKING GARAGE ELEVATOR**

This agreement (the “Agreement”) supplements the Facility Repair and Maintenance Contract and is entered between the City of Bloomington, Department of Public Works (the “Department”), and Kone, Inc. (“Contractor”). The Agreement states:

Article 1. Scope of Services After receiving a **Notice to Proceed**, Contractor shall perform removal and replacement of the Morton Street garage elevator, which will include: new build out of the shaft for the new cab; demolition/replacement of existing OTIS Gen 2 MRL Elevator system, including entrances (frames/doors) and entrance sills, using Contractor’s complete new A.C. Gearless MRL Electric Traction elevator system. These services will be performed at the City of Bloomington Morton Street garage (“Services”) for a set price of Three Hundred and Sixty Seven Thousand dollars (\$367,000). Contractor shall diligently provide the Services under this Agreement and shall complete the Services described in this Agreement in a timely manner consistent with the Standard of Care identified in Article 2. Contractor shall complete the Services required under this Agreement on or before November, 2024, unless the parties mutually agree to a later completion date. Completion shall mean completion of all work related to the Services. In the performance of Contractor’s work, Contractor agrees to maintain such coordination with the Department as may be requested and desirable, including primary coordination with Jessica Goodman, Parking Garage Manager, Public Works Department, Parking Services Division. Contractor agrees that any information or documents, including digital GIS information, supplied by the Department pursuant to Article 3, below, shall be used by Contractor for this project only, and shall not be reused or reassigned for any other purpose without the written permission of the Department.

Article 2. Standard of Care Contractor shall be responsible for completion of the Services in a manner consistent with that degree of care and skill ordinarily exercised by members of the same profession currently practicing under similar circumstances (“Standard of Care”). The Department shall be the sole judge of the adequacy of Contractor’s work in meeting the Standard of Care; however, the Department shall not unreasonably withhold its approval as to the adequacy of Contractor’s performance. Upon notice to Contractor and by mutual agreement between the parties, Contractor will, without additional compensation, correct or replace any and all Services not meeting the Standard of Care.

Article 3. Responsibilities of the Department The Department shall provide all necessary information regarding requirements for the Services. The Department shall furnish such information as necessary for the orderly progress of the work, and Contractor shall be entitled to rely upon the accuracy and completeness of such information. The Department’s Project Manager shall act on its behalf with respect to this Agreement.

Article 4. Compensation The Department shall pay Contractor for all fees and expenses in an amount not to exceed Three Hundred and Sixty Seven Thousand dollars (\$367,000). Contractor shall submit an invoice to the Department upon the completion of the Services described in Article 1. The invoice shall be sent to: Jessica Goodman, City of Bloomington Public Works, 401 N. Morton, Suite 120, Bloomington, Indiana 47404. Invoices may be sent via first class mail postage prepaid or via email. Payment will be remitted to Contractor within forty-five (45) days of receipt of invoice. Additional services not set forth in Article 1, or changes in the Services must be authorized in writing by the Department or its designated project coordinator prior to such work being performed, or expenses incurred. The Department shall not make payment for any unauthorized work or expenses.

Article 5. Appropriation of Funds Notwithstanding any other provision of this Agreement, if funds for the continued fulfillment of this Agreement by the Department are at any time not forthcoming or are insufficient, through failure of any entity, including the Department itself, to appropriate funds or otherwise, then the Department shall have the right to terminate this Agreement without penalty.

Article 6. Insurance During the performance of any and all Services under this Agreement, Contractor shall maintain the following insurance in full force and effect: a) General Liability Insurance, with a minimum combined single limit of \$1,000,000 for each occurrence and \$2,000,000 in the aggregate; b) Automobile Liability Insurance, with a minimum combined single limit of \$1,000,000 for each person and \$1,000,000 for each accident; c) Workers' Compensation Insurance in accordance with the statutory requirements of Title 22 of the Indiana Code; d) Professional Liability Insurance ("Errors and Omissions Insurance") with a minimum limit of \$1,000,000 annual aggregate; and e) Umbrella Excess Liability of \$5,000,000 for each occurrence and aggregate. All insurance policies shall be issued by an insurance company authorized to issue such insurance in the State of Indiana. The City of Bloomington, the Department, and the officers, employees and agents of each shall be named as insureds under the General Liability, Automobile, and Worker's Compensation policies, and such policies shall stipulate that the insurance will operate as primary insurance and that no other insurance of the City's will be called upon to contribute to a loss hereunder. Contractor shall provide evidence of each insurance policy to the Department prior to the commencement of work under this Agreement.

Article 7. Third Party Rights Nothing in this Agreement shall be construed to give any rights or benefits to anyone other than the parties.

Article 8. Governing Law and Venue This Agreement shall be governed by the laws of the State of Indiana. Venue of any disputes arising under this Agreement shall be in the Monroe Circuit Court, Monroe County, Indiana.

Article 9. Non-Discrimination Contractor shall comply with City of Bloomington Ordinance 2.21.020 and all other federal, state and local laws and regulations governing non-discrimination in all regards, including, but not limited to, employment. Contractor understands that the City of Bloomington prohibits its employees from engaging in harassment or discrimination of any kind, including harassing or discriminating against independent contractors doing work for the City. If the Contractor believes that a City employee engaged in such conduct towards Contractor and/or any of its employees, Contractor or its employees may file a complaint with the City department head in charge of the Contractor's work and/or with the City human resources department or the Bloomington Human Rights Commission. The City takes all complaints of harassment and discrimination seriously and will take appropriate disciplinary action if it finds that any City employee engaged in such prohibited conduct.

Article 10. Compliance with Laws In performing the Services under this Agreement, Contractor shall comply with any and all applicable federal, state and local statutes, ordinances, plans and regulations, including any and all regulations for protection of the environment. Where such statutes, ordinances, plans or regulations of any public authority having any jurisdiction over the project are in conflict, Contractor shall proceed using its best judgment only after attempting to resolve any such conflict between such governmental agencies, and shall notify the Department in a timely manner of the conflict, attempts of resolution, and planned course of action.

Article 11. E-Verify Contractor is required to enroll in and verify the work eligibility status of all newly-hired employees through the E-Verify program. (This is not required if the E-Verify program no longer exists). Contractor shall sign an affidavit, attached as Exhibit A, affirming that Contractor does not knowingly employ an unauthorized alien. Contractor shall require any subcontractors performing work under this contract to certify to the Contractor that, at the time of certification, the subcontractor does not knowingly employ or contract with an unauthorized alien and the subcontractor has enrolled in and is participating in the E-Verify program. Contractor shall maintain on file all subcontractors' certifications throughout the term of the contract with the City.

Article 12. Notices Any notice required by this Agreement shall be made in writing to the individuals/addresses specified below:

Department: City of Bloomington Public Works, Attn: Jess Goodman, 401 N. Morton, Suite 120, Bloomington, Indiana 47404.

Contractor: KONE INC 5201 Park Emerson Drive, Suite O Indianapolis, Indiana 46203.

Nothing contained in this Article shall be construed to restrict the transmission of routine communications between representatives of the Department and Contractor.

Article 13. Integration and Modification This Amendment, including all exhibits incorporated by reference, together with the Agreement represent the entire and integrated Agreement between the Department and the Contractor. It supersedes all prior and contemporaneous communications, representations and agreements, whether oral or written, relating to the subject matter of this Agreement. This Agreement may be modified only by a written amendment signed by both parties hereto.

Article 15. Non-Collusion Contractor is required to certify that it has not, nor has any other member, representative, or agent of Contractor, entered into any combination, collusion, or agreement with any person relative to the price to be offered by any person nor prevented any person from making an offer nor induced anyone to refrain from making an offer and that this offer is made without reference to any other offer. Contractor shall sign an affidavit, attached hereto as Exhibit B, affirming that Contractor has not engaged in any collusive conduct. Exhibit B is attached hereto and incorporated by reference as though fully set forth.

Article 16. Living Wage Ordinance. Contractor is considered a “covered employer” under City Ordinance 2.28, otherwise known as the “Living Wage Ordinance,” or “LWO,” and is required to pay their covered employees at least a living wage. Currently, the living wage is \$15.75 per hour for covered employees, and up to 15% of that amount, or \$2.36, may be in the form the covered employer’s contribution to health insurance available to the covered employee.

Contractor shall execute the Living Wage Ordinance Affidavit, attached as Exhibit C; shall abide by the LWO by paying their employees a living wage; and shall post the Living Wage Poster, provided by the City Legal Department, in areas frequented by their covered employees.

IN WITNESS WHEREOF, the parties have caused this Amendment to be executed the day and year last written below:

CITY OF BLOOMINGTON

KONE, INC

Margie Rice, Corporation Counsel

John Hadley, Branch Manager

CITY OF BLOOMINGTON PUBLIC WORKS

Adam Wason, Director

Kyla Cox Deckard, President, Board of Public Works

EXHIBIT B

STATE OF INDIANA)
) SS:
COUNTY OF _____)

NON-COLLUSION AFFIDAVIT

The undersigned offeror or agent, being duly sworn on oath, says that he has not, nor has any other member, representative, or agent of the firm, company, corporation or partnership represented by him, entered into any combination, collusion or agreement with any person relative to the price to be offered by any person nor to prevent any person from making an offer nor to induce anyone to refrain from making an offer and that this offer is made without reference to any other offer.

OATH AND AFFIRMATION

I affirm under the penalties of perjury that the foregoing facts and information are true and correct to the best of my knowledge and belief.

Dated this _____ day of _____, 20____.

KONE, INC

By: _____

STATE OF INDIANA)
) SS:
COUNTY OF _____)

Before me, a Notary Public in and for said County and State, personally appeared _____ and acknowledged the execution of the foregoing this _____ day of _____, 2024.

Notary Public Printed Name

Notary Public's Signature

My Commission Expires: _____

County of Residence: _____

My Commission #: _____

EXHIBIT "C"

AFFIDAVIT THE LIVING WAGE ORDINANCE

The undersigned, being duly sworn, hereby affirms and says that:

1. The undersigned is the [Click here to enter text.](#) of [Click here to enter text.](#)
(job title) (company name)
2. The company named herein that employs the undersigned has contracted with or is seeking to contract with the City of Bloomington to provide services.
3. The undersigned hereby states that, to the best of their knowledge and belief, the company named herein is subject to Bloomington City Ordinance 2.28, otherwise known as the "Living Wage Ordinance."
4. The projected employment needs under the award include the following: [Click here to enter text.](#)
5. The projected net increase or decrease in jobs for covered employees by job title that will result from awarding the assistance: [Click here to enter text.](#)
6. The undersigned hereby affirms that the smallest hourly wage to be earned by each of their covered employees shall be at least the living wage.

I affirm under the penalties of perjury that the foregoing facts and information are true and correct to the best of my knowledge and belief.

Signature

Printed name

STATE OF INDIANA)
) SS:
COUNTY OF _____)

Before me, a Notary Public in and for said County and State, personally appeared _____
_____ and acknowledged the execution of the foregoing this _____ day of _____
_____, 2024.

My Commission Expires: _____

Notary Public

County of Residence: _____

Name Printed

Commission Number



Board of Public Works Staff Report

Project/Event: 2024 Walnut Street Garage Elevator Replacement
Petitioner/Representative: PW Parking Services, Jess Goodman
Staff Representative: Jess Goodman
Date: 3.08.2024

Report:

Kone, INC Walnut Street Garage Elevator Replacement:
Kone will be replacing and upgrading the Walnut St. garage elevator. This will include:

-New Hydraulic Power Unit

- KONE will install a new Hydraulic Submersible Power Unit. This has a 50HP motor, 200GPM IMO Pump, Maxton Valve, 12 gallon Enamel Tank, isolated anchoring feet, and noise reducing muffler.

-New GAL Door Operator with ALL New Equipment

- KONE will install a GAL MOVFE Closed Loop high-performance Door Operator that has become a proven industry mainstay due to its reliability and robust construction. It is designed to be virtually maintenance-free, this system continues to outperform its competition in terms of cost-efficiency. This includes tracks, hangers, interlocks, clutch on car side.

-Install new Fixtures including the buttons inside the elevator and in both hallways

- KONE will install all new elevator internal buttons on the Control Operating Panel and all new buttons on all five landings. You will have some options of design and color as well.

-Cab Interior Replacement

- KONE will replace three full walls in the elevator with an agreed upon design, along with a back wall handrail. This also includes new Stainless Steel Transom, Frames and Return. Finally, KONE will install a new Stainless Steel Ceiling with LED Lighting. You will have three choices for the wall colors. THIS DOES NOT INCLUDE FLOORING.

Total cost of contract = \$184,550.20

Project Funding Source: 101-26-260000-54510 (CRED Fund Line)



Recommend **Approval** **Denial by:** Jess Goodman

City of Bloomington Contract and Purchase Justification Form

Vendor: Kone, INC

Contract Amount: 184,550.20

This form should be completed and attached to the contract documents and forwarded to the Legal Department Attorney assigned to your Department. Contracts will not be approved by the Controller if a completed form is not included with the contract documents.

PURCHASE INFORMATION

1. Check the box beside the procurement method used to initiate this procurement: (Attach a quote or bid tabulation if applicable)

<input type="checkbox"/> Request for Quote (RFQ)	<input type="checkbox"/> Request for Proposal (RFP)	<input checked="" type="checkbox"/> Sole Source	<input type="checkbox"/> Not Applicable (NA)
<input type="checkbox"/> Invitation to Bid (ITB)	<input type="checkbox"/> Request for Qualifications (RFQu)	<input type="checkbox"/> Emergency Purchase	

2. List the results of procurement process. Give further explanation where requested. Yes No

# of Submittals:	Yes	No	Was the lowest cost selected? (If no, please state below why it was not.)
Met city requirements?	<input checked="" type="checkbox"/>	<input type="checkbox"/>	<input type="checkbox"/> Yes <input checked="" type="checkbox"/> No
Met item or need requirements?	<input checked="" type="checkbox"/>	<input type="checkbox"/>	Kone is the City of Bloomington Parking Garage Elevator service provider for 2024. Kone is part of the Omnia co-op program that City of Bloomington is a part of. This will provide discounts and other services for the elevator installation.
Was an evaluation team used?	<input type="checkbox"/>	<input checked="" type="checkbox"/>	
Was scoring grid used?	<input type="checkbox"/>	<input checked="" type="checkbox"/>	
Were vendor presentations requested?	<input type="checkbox"/>	<input checked="" type="checkbox"/>	

3. State why this vendor was selected to receive the award and contract:

Kone, INC is our 2024 service provider for the City of Bloomington Parking Garages. Kone and the City of Bloomington are part of the Omnia co-op which provides discounts on elevator parts, material, and installation.

Jess Goodman

Parking Garage Manager

Public Works/Parking Services

Print/Type Name

Print/Type Title

Department

**AGREEMENT BETWEEN CITY OF BLOOMINGTON PUBLIC WORKS
DEPARTMENT AND KONE, INC. FOR THE
WALNUT STREET PARKING GARAGE ELEVATOR**

This agreement (the “Agreement”) supplements the Facility Repair and Maintenance Contract and is entered between the City of Bloomington, Department of Public Works (the “Department”), and Kone, Inc. (“Contractor”). The Agreement states:

Article 1. Scope of Services After receiving a **Notice to Proceed**, Contractor shall perform upgrading and replacement of the Walnut Street garage elevator, which will include: upgrading and replacement of existing OTIS Elevator system, including new hydraulic power unit, new GAL door operator with new equipment, new fixtures, including buttons, and cab interior. These services will be performed at the City of Bloomington Walnut Street garage (“Services”) for a set price of One Hundred Eighty Four Thousand, Five Hundred Fifty Dollars and Twenty Cents (\$184,550.20). Contractor shall diligently provide the Services under this Agreement and shall complete the Services described in this Agreement in a timely manner consistent with the Standard of Care identified in Article 2. Contractor shall complete the Services required under this Agreement on or before November, 2024, unless the parties mutually agree to a later completion date. Completion shall mean completion of all work related to the Services. In the performance of Contractor’s work, Contractor agrees to maintain such coordination with the Department as may be requested and desirable, including primary coordination with Jessica Goodman, Parking Garage Manager, Public Works Department, Parking Services Division. Contractor agrees that any information or documents, including digital GIS information, supplied by the Department pursuant to Article 3, below, shall be used by Contractor for this project only, and shall not be reused or reassigned for any other purpose without the written permission of the Department.

Article 2. Standard of Care Contractor shall be responsible for completion of the Services in a manner consistent with that degree of care and skill ordinarily exercised by members of the same profession currently practicing under similar circumstances (“Standard of Care”). The Department shall be the sole judge of the adequacy of Contractor’s work in meeting the Standard of Care; however, the Department shall not unreasonably withhold its approval as to the adequacy of Contractor’s performance. Upon notice to Contractor and by mutual agreement between the parties, Contractor will, without additional compensation, correct or replace any and all Services not meeting the Standard of Care.

Article 3. Responsibilities of the Department The Department shall provide all necessary information regarding requirements for the Services. The Department shall furnish such information as necessary for the orderly progress of the work, and Contractor shall be entitled to rely upon the accuracy and completeness of such information. The Department’s Project Manager shall act on its behalf with respect to this Agreement.

Article 4. Compensation The Department shall pay Contractor for all fees and expenses in an amount not to exceed One Hundred Eighty Four Thousand, Five Hundred Fifty Dollars and Twenty Cents (\$184,550.20). Contractor shall submit an invoice to the Department upon the completion of the Services described in Article 1. The invoice shall be sent to: Jessica Goodman, City of Bloomington Public Works, 401 N. Morton, Suite 120, Bloomington, Indiana 47404. Invoices may be sent via first class mail postage prepaid or via email. Payment will be remitted to Contractor within forty-five (45) days of receipt of invoice. Additional services not set forth in Article 1, or changes in the Services must be authorized in writing by the Department or its designated project coordinator prior to such work being performed, or expenses incurred. The Department shall not make payment for any unauthorized work or expenses.

Article 5. Appropriation of Funds Notwithstanding any other provision of this Agreement, if funds for the continued fulfillment of this Agreement by the Department are at any time not forthcoming or are insufficient, through failure of any entity, including the Department itself, to appropriate funds or otherwise, then the Department shall have the right to terminate this Agreement without penalty.

Article 6. Insurance During the performance of any and all Services under this Agreement, Contractor shall maintain the following insurance in full force and effect: a) General Liability Insurance, with a minimum combined single limit of \$1,000,000 for each occurrence and \$2,000,000 in the aggregate; b) Automobile Liability Insurance, with a minimum combined single limit of \$1,000,000 for each person and \$1,000,000 for each accident; c) Workers' Compensation Insurance in accordance with the statutory requirements of Title 22 of the Indiana Code; d) Professional Liability Insurance ("Errors and Omissions Insurance") with a minimum limit of \$1,000,000 annual aggregate; and e) Umbrella Excess Liability of \$5,000,000 for each occurrence and aggregate. All insurance policies shall be issued by an insurance company authorized to issue such insurance in the State of Indiana. The City of Bloomington, the Department, and the officers, employees and agents of each shall be named as insureds under the General Liability, Automobile, and Worker's Compensation policies, and such policies shall stipulate that the insurance will operate as primary insurance and that no other insurance of the City's will be called upon to contribute to a loss hereunder. Contractor shall provide evidence of each insurance policy to the Department prior to the commencement of work under this Agreement.

Article 7. Third Party Rights Nothing in this Agreement shall be construed to give any rights or benefits to anyone other than the parties.

Article 8. Governing Law and Venue This Agreement shall be governed by the laws of the State of Indiana. Venue of any disputes arising under this Agreement shall be in the Monroe Circuit Court, Monroe County, Indiana.

Article 9. Non-Discrimination Contractor shall comply with City of Bloomington Ordinance 2.21.020 and all other federal, state and local laws and regulations governing non-discrimination in all regards, including, but not limited to, employment. Contractor understands that the City of Bloomington prohibits its employees from engaging in harassment or discrimination of any kind, including harassing or discriminating against independent contractors doing work for the City. If the Contractor believes that a City employee engaged in such conduct towards Contractor and/or any of its employees, Contractor or its employees may file a complaint with the City department head in charge of the Contractor's work and/or with the City human resources department or the Bloomington Human Rights Commission. The City takes all complaints of harassment and discrimination seriously and will take appropriate disciplinary action if it finds that any City employee engaged in such prohibited conduct.

Article 10. Compliance with Laws In performing the Services under this Agreement, Contractor shall comply with any and all applicable federal, state and local statutes, ordinances, plans and regulations, including any and all regulations for protection of the environment. Where such statutes, ordinances, plans or regulations of any public authority having any jurisdiction over the project are in conflict, Contractor shall proceed using its best judgment only after attempting to resolve any such conflict between such governmental agencies, and shall notify the Department in a timely manner of the conflict, attempts of resolution, and planned course of action.

Article 11. E-Verify Contractor is required to enroll in and verify the work eligibility status of all newly-hired employees through the E-Verify program. (This is not required if the E-Verify program no longer exists). Contractor shall sign an affidavit, attached as Exhibit A, affirming that Contractor does not knowingly employ an unauthorized alien. Contractor shall require any subcontractors performing work under this contract to certify to the Contractor that, at the time of certification, the subcontractor does not knowingly employ or contract with an unauthorized alien and the subcontractor has enrolled in and is participating in the E-Verify program. Contractor shall maintain on file all subcontractors' certifications throughout the term of the contract with the City.

Article 12. Notices Any notice required by this Agreement shall be made in writing to the individuals/addresses specified below:

Department: City of Bloomington Public Works, Attn: Jess Goodman, 401 N. Morton, Suite 120, Bloomington, Indiana 47404.

Contractor: KONE INC 5201 Park Emerson Drive, Suite O Indianapolis, Indiana 46203.

Nothing contained in this Article shall be construed to restrict the transmission of routine communications between representatives of the Department and Contractor.

Article 13. Integration and Modification This Amendment, including all exhibits incorporated by reference, together with the Agreement represent the entire and integrated Agreement between the Department and the Contractor. It supersedes all prior and contemporaneous communications, representations and agreements, whether oral or written, relating to the subject matter of this Agreement. This Agreement may be modified only by a written amendment signed by both parties hereto.

Article 15. Non-Collusion Contractor is required to certify that it has not, nor has any other member, representative, or agent of Contractor, entered into any combination, collusion, or agreement with any person relative to the price to be offered by any person nor prevented any person from making an offer nor induced anyone to refrain from making an offer and that this offer is made without reference to any other offer. Contractor shall sign an affidavit, attached hereto as Exhibit B, affirming that Contractor has not engaged in any collusive conduct. Exhibit B is attached hereto and incorporated by reference as though fully set forth.

Article 16. Living Wage Ordinance. Contractor is considered a “covered employer” under City Ordinance 2.28, otherwise known as the “Living Wage Ordinance,” or “LWO,” and is required to pay their covered employees at least a living wage. Currently, the living wage is \$15.75 per hour for covered employees, and up to 15% of that amount, or \$2.36, may be in the form the covered employer’s contribution to health insurance available to the covered employee.

Contractor shall execute the Living Wage Ordinance Affidavit, attached as Exhibit C; shall abide by the LWO by paying their employees a living wage; and shall post the Living Wage Poster, provided by the City Legal Department, in areas frequented by their covered employees.

IN WITNESS WHEREOF, the parties have caused this Amendment to be executed the day and year last written below:

CITY OF BLOOMINGTON

KONE, INC

Margie Rice, Corporation Counsel

John Hadley, Branch Manager

CITY OF BLOOMINGTON PUBLIC WORKS

Adam Wason, Director

Kyla Cox Deckard, President, Board of Public Works

EXHIBIT A
E-VERIFY AFFIDAVIT

STATE OF INDIANA)
)SS:
COUNTY OF _____)

AFFIDAVIT

The undersigned, being duly sworn, hereby affirms and says that:

1. The undersigned is the _____ of _____.
 (job title) (company name)
2. The company named herein that employs the undersigned:
 - i. has contracted with or seeking to contract with the City of Bloomington to provide services; **OR**
 - ii. is a subcontractor on a contract to provide services to the City of Bloomington.
3. The undersigned hereby states that, to the best of his/her knowledge and belief, the company named herein does not knowingly employ an "unauthorized alien," as defined at 8 United States Code 1324a(h)(3).
4. The undersigned hereby states that, to the best of his/her belief, the company named herein is enrolled in and participates in the E-verify program.

Signature

Printed Name

STATE OF INDIANA)
)SS:
COUNTY OF _____)

Before me, a Notary Public in and for said County and State, personally appeared _____ and acknowledged the execution of the foregoing this ____ day of _____, 20____.

Notary Public Printed Name

Notary Public's Signature

My Commission Expires: _____

County of Residence: _____

My Commission #: _____

EXHIBIT B

STATE OF INDIANA)
) SS:
COUNTY OF _____)

NON-COLLUSION AFFIDAVIT

The undersigned offeror or agent, being duly sworn on oath, says that he has not, nor has any other member, representative, or agent of the firm, company, corporation or partnership represented by him, entered into any combination, collusion or agreement with any person relative to the price to be offered by any person nor to prevent any person from making an offer nor to induce anyone to refrain from making an offer and that this offer is made without reference to any other offer.

OATH AND AFFIRMATION

I affirm under the penalties of perjury that the foregoing facts and information are true and correct to the best of my knowledge and belief.

Dated this _____ day of _____, 20____.

KONE, INC

By: _____

STATE OF INDIANA)
) SS:
COUNTY OF _____)

Before me, a Notary Public in and for said County and State, personally appeared _____ and acknowledged the execution of the foregoing this _____ day of _____, 2024.

Notary Public Printed Name

Notary Public's Signature

My Commission Expires: _____

County of Residence: _____

My Commission #: _____

EXHIBIT "C"

AFFIDAVIT THE LIVING WAGE ORDINANCE

The undersigned, being duly sworn, hereby affirms and says that:

1. The undersigned is the [Click here to enter text.](#) of [Click here to enter text.](#)
(job title) (company name)
2. The company named herein that employs the undersigned has contracted with or is seeking to contract with the City of Bloomington to provide services.
3. The undersigned hereby states that, to the best of their knowledge and belief, the company named herein is subject to Bloomington City Ordinance 2.28, otherwise known as the "Living Wage Ordinance."
4. The projected employment needs under the award include the following: [Click here to enter text.](#)
5. The projected net increase or decrease in jobs for covered employees by job title that will result from awarding the assistance: [Click here to enter text.](#)
6. The undersigned hereby affirms that the smallest hourly wage to be earned by each of their covered employees shall be at least the living wage.

I affirm under the penalties of perjury that the foregoing facts and information are true and correct to the best of my knowledge and belief.

Signature

Printed name

STATE OF INDIANA)
) SS:
COUNTY OF _____)

Before me, a Notary Public in and for said County and State, personally appeared _____
_____ and acknowledged the execution of the foregoing this _____ day of _____
_____, 2024.

My Commission Expires: _____

Notary Public

County of Residence: _____

Name Printed

Commission Number



Board of Public Works Claim Register

Invoice Date Range 03/02/24 - 03/15/24

Vendor	Invoice Description	Contract #	Payment Date	Invoice Amount
Fund 101 - General Fund (S0101)				
Department 01 - Animal Shelter				
Program 010000 - Main				
Account 52110 - Office Supplies				
6530 - Office Depot, INC	01-Staplers		03/15/2024	4.83
6530 - Office Depot, INC	01-Cable ties		03/15/2024	4.99
6530 - Office Depot, INC	01-Photo paper		03/15/2024	5.99
6530 - Office Depot, INC	01-Cable ties		03/15/2024	9.99
6530 - Office Depot, INC	01-Stapler		03/15/2024	11.74
6530 - Office Depot, INC	01-Monitor stand for the workroom		03/15/2024	25.85
6530 - Office Depot, INC	01-Monitor stand for director's office		03/15/2024	29.99
6530 - Office Depot, INC	01-Monitor stand for front desk		03/15/2024	29.99
Account 52110 - Office Supplies Totals			Invoice 8 Transactions	\$123.37
Account 52210 - Institutional Supplies				
4586 - Hill's Pet Nutrition Sales, INC	01-Dog, puppy & cat food		03/15/2024	160.94
4586 - Hill's Pet Nutrition Sales, INC	01-Dog, puppy, kitten & cat food		03/15/2024	244.08
4586 - Hill's Pet Nutrition Sales, INC	01-Dog, puppy & cat food		03/15/2024	120.22
4586 - Hill's Pet Nutrition Sales, INC	01-Prescription Veterinary Food		03/15/2024	215.71
4586 - Hill's Pet Nutrition Sales, INC	01-Prescription Veterinary Food		03/15/2024	198.46
4574 - John Deere Financial f.s.b. (Rural King)	01-Laundry soap		03/15/2024	32.97
4549 - Kroger Limited Partnership I	01-rabbit & lizard (iguana) food-2/29/24		03/15/2024	18.89
4633 - Midwest Veterinary Supply, INC	01-Toungue depresors		03/15/2024	8.23



Board of Public Works Claim Register

Invoice Date Range 03/02/24 - 03/15/24

4633 - Midwest Veterinary Supply, INC	01-Spray Bottles (8)	03/15/2024	22.43
4633 - Midwest Veterinary Supply, INC	01-vinyl exam gloves (L)	03/15/2024	26.60
4633 - Midwest Veterinary Supply, INC	01-vinyl exam gloves (L)	03/15/2024	27.35
4633 - Midwest Veterinary Supply, INC	01-vinyl exam gloves (L)	03/15/2024	27.35
4633 - Midwest Veterinary Supply, INC	01-Beneficial bac, dermatophyte for plates	03/15/2024	39.60
4633 - Midwest Veterinary Supply, INC	01-Syringes	03/15/2024	236.70
4633 - Midwest Veterinary Supply, INC	01-Collars, fluids, antibiotics	03/15/2024	348.12
4633 - Midwest Veterinary Supply, INC	01-Antibiotics, asst. vet supplies	03/15/2024	468.20
4633 - Midwest Veterinary Supply, INC	01-Antibiotics, antiparsitics, anti fungal medication	03/15/2024	561.23
4633 - Midwest Veterinary Supply, INC	01-Antibiotics, antiparasitics, milk replacer	03/15/2024	895.72
4633 - Midwest Veterinary Supply, INC	01-Antiparasitics, antibiotics, trazodone	03/15/2024	1,109.91
4633 - Midwest Veterinary Supply, INC	01-Antiparasitics, milk replacer	03/15/2024	1,239.33
Account 52210 - Institutional Supplies Totals		Invoice 20 Transactions	<u>\$6,002.04</u>
Account 52310 - Building Materials and Supplies			
8541 - Amazon.com Sales, INC (Amazon.com Services LLC)	01-Seat & shelving for outreach area	03/15/2024	259.98
Account 52310 - Building Materials and Supplies Totals		Invoice 1 Transactions	<u>\$259.98</u>
Account 52340 - Other Repairs and Maintenance			
313 - Fastenal Company	01-Towels, spray nozzle hose end	03/15/2024	125.64
Account 52340 - Other Repairs and Maintenance Totals		Invoice 1 Transactions	<u>\$125.64</u>
Account 52420 - Other Supplies			
53442 - Paragon Micro, INC	01-Surge Protector w/ Battery Backup	03/15/2024	149.98
53442 - Paragon Micro, INC	01 - 3 computer monitors and docks	03/15/2024	1,493.94
Account 52420 - Other Supplies Totals		Invoice 2 Transactions	<u>\$1,643.92</u>



Board of Public Works Claim Register

Invoice Date Range 03/02/24 - 03/15/24

Account 52430 - Uniforms and Tools

4832 - Animal Care Equipment & Services, LLC	01-cat trap	03/15/2024	111.00
4832 - Animal Care Equipment & Services, LLC	01-darts, needles, cat trap	03/15/2024	109.68
Account 52430 - Uniforms and Tools Totals		Invoice 2 Transactions	\$220.68

Account 53130 - Medical

54639 - Shake Veterinary Services, INC (Town & Country Vet	01-Exam & pain management-1/23/24	03/15/2024	99.01
54639 - Shake Veterinary Services, INC (Town & Country Vet	01-Wormer given during vet appointment-2/13/24	03/15/2024	5.15
54639 - Shake Veterinary Services, INC (Town & Country Vet	01-Dental surgery & x-rays-2/20/24	03/15/2024	342.99
Account 53130 - Medical Totals		Invoice 3 Transactions	\$447.15

Account 53160 - Instruction

3560 - First Financial Bank / Credit Cards	01-Solving The People Problem Training	03/15/2024	99.00
Account 53160 - Instruction Totals		Invoice 1 Transactions	\$99.00

Account 53220 - Postage

3560 - First Financial Bank / Credit Cards	01-UPS Store-BOH Shipping -2/1/24	03/15/2024	13.46
3560 - First Financial Bank / Credit Cards	01-UPS Store-BOH Shipping 02/15/24	03/15/2024	13.46
3560 - First Financial Bank / Credit Cards	01-USPS-Certified Mail -2/21/24	03/15/2024	8.73
Account 53220 - Postage Totals		Invoice 3 Transactions	\$35.65

Account 53910 - Dues and Subscriptions

3560 - First Financial Bank / Credit Cards	01-Shelter Manager membership to Association for Animal Welfare	03/15/2024	250.00
Account 53910 - Dues and Subscriptions Totals		Invoice 1 Transactions	\$250.00
Program 010000 - Main Totals		Invoice 42 Transactions	\$9,207.43

Program 010001 - Donations Over \$5K

Account 52420 - Other Supplies



Board of Public Works Claim Register

Invoice Date Range 03/02/24 - 03/15/24

6222 - Apple, INC

01 - iPad for Volunteer Kiosk	03/15/2024	628.00
Account 52420 - Other Supplies Totals	Invoice 1	<u>\$628.00</u>
	Transactions	

Account **53130 - Medical**

6529 - BloomingPaws, LLC

01-Mass removal surgery & biopsy	03/15/2024	690.82
Account 53130 - Medical Totals	Invoice 1	<u>\$690.82</u>
	Transactions	
Program 010001 - Donations Over \$5K Totals	Invoice 2	<u>\$1,318.82</u>
	Transactions	
Department 01 - Animal Shelter Totals	Invoice 44	<u>\$10,526.25</u>
	Transactions	

Department **02 - Public Works**

Program **020000 - Main**

Account **46060 - Other Violations**

EAN Holdings LLC

26-EAN made payment for check that was already paid	03/15/2024	60.00
---	------------	-------

Sarah Jacobi

26-Ticket was written in error	03/15/2024	30.00
--------------------------------	------------	-------

Account 46060 - Other Violations Totals	Invoice 2	<u>\$90.00</u>
	Transactions	

Account **52110 - Office Supplies**

8541 - Amazon.com Sales, INC (Amazon.com Services LLC)

02-Frame for Org Chart	03/15/2024	31.44
------------------------	------------	-------

8541 - Amazon.com Sales, INC (Amazon.com Services LLC)

02-Return of Broken Frame for Org Chart	03/15/2024	(31.44)
---	------------	---------

6530 - Office Depot, INC

02-Pens for Public Works Admin	03/15/2024	9.96
--------------------------------	------------	------

Account 52110 - Office Supplies Totals	Invoice 3	<u>\$9.96</u>
	Transactions	

Account **52420 - Other Supplies**

651 - Engraving & Stamp Center, INC

02-Signature Stamp new Board of Public Works member James Roach	03/15/2024	33.50
---	------------	-------

3404 - J.R. Watkins & Family, INC (Signs Now)

02-Nameplate for Board of Public Works Member James Roach	03/15/2024	26.00
---	------------	-------

53442 - Paragon Micro, INC

02-Computer Docking_Charging Station for April Rosenberaer	03/15/2024	259.99
--	------------	--------

Account 52420 - Other Supplies Totals	Invoice 3	<u>\$319.49</u>
	Transactions	



Board of Public Works Claim Register

Invoice Date Range 03/02/24 - 03/15/24

Account 53160 - Instruction

4498 - American Public Works Association	02-PW Management Accreditation Manuals (12)	03/15/2024	1,140.00
3560 - First Financial Bank / Credit Cards	02-Asset Mgmt Software User Conference-Nicholas Spanolo	03/15/2024	800.00
9183 - RainFocus, LLC	02-Trimble/Cityworks Conf Fee-Nickel/Boruff/Stephens/Bowlen	03/15/2024	720.00
Account 53160 - Instruction Totals		Invoice 3	\$2,660.00
		Transactions	

Account 53910 - Dues and Subscriptions

4498 - American Public Works Association	02-Membership-Sanitation Director Lazarus Sears-prorated	03/15/2024	116.08
Account 53910 - Dues and Subscriptions Totals		Invoice 1	\$116.08
		Transactions	

Account 53990 - Other Services and Charges

3560 - First Financial Bank / Credit Cards	02-Car Washcity car-Adam Wason after encampment cleanup-2/4/2024	03/15/2024	10.00
3560 - First Financial Bank / Credit Cards	02-Car Wash-city car-Adam Wason after encampment cleanup-2/29/24	03/15/2024	10.00
3892 - Midwest Color Printing, INC	02-250 Business Cards for Michael Large	03/15/2024	65.14
Account 53990 - Other Services and Charges Totals		Invoice 3	\$85.14
		Transactions	
Program 020000 - Main Totals		Invoice 15	\$3,280.67
		Transactions	
Department 02 - Public Works Totals		Invoice 15	\$3,280.67
		Transactions	

Department 03 - City Clerk

Program 030000 - Main

Account 52110 - Office Supplies

8541 - Amazon.com Sales, INC (Amazon.com Services LLC)	03-Hard shell computer cover	03/15/2024	38.99
8541 - Amazon.com Sales, INC (Amazon.com Services LLC)	03-Protective laptop sleeve	03/15/2024	19.79
3560 - First Financial Bank / Credit Cards	03-Parking Bolden ILMCT Exec Committee Meeting-Indv	03/15/2024	48.00
Account 52110 - Office Supplies Totals		Invoice 3	\$106.78
		Transactions	

Account 53160 - Instruction



Board of Public Works Claim Register

Invoice Date Range 03/02/24 - 03/15/24

3913 - Indiana League Of Municipal Clerks & Treasurers	03-ILMCT conference fee - Crossley-March 2024	03/15/2024	450.00
3913 - Indiana League Of Municipal Clerks & Treasurers	03-ILMCT conference fee - McDowell-March 2024	03/15/2024	450.00
3913 - Indiana League Of Municipal Clerks & Treasurers	03-ILMCT conference fee - Bolden-March 2024	03/15/2024	450.00
3913 - Indiana League Of Municipal Clerks & Treasurers	03-ILMCT Annual Conference - 2023 Dana Black	03/15/2024	450.00

Account 53160 - Instruction Totals	Invoice 4	\$1,800.00
	Transactions	

Account **53230 - Travel**

5461 - Nicole Bolden	03-ILMCT Exec Committee Mtg-Indy-2/20/24	03/15/2024	128.38
3560 - First Financial Bank / Credit Cards	03-Staples- cardstock	03/15/2024	21.98
3560 - First Financial Bank / Credit Cards	03-Parking Bolden ILMCT Exec Committee Meeting-Indv	03/15/2024	23.25

Account 53230 - Travel Totals	Invoice 3	\$173.61
--------------------------------------	-----------	----------

Program 030000 - Main Totals	Transactions Invoice 10	\$2,080.39
-------------------------------------	-------------------------	------------

Department 03 - City Clerk Totals	Transactions Invoice 10	\$2,080.39
--	-------------------------	------------

Transactions Invoice 10	\$2,080.39
Transactions Invoice 10	\$2,080.39

Department **04 - Economic & Sustainable Dev**

Program **040000 - Main**

Account **52110 - Office Supplies**

8541 - Amazon.com Sales, INC (Amazon.com Services LLC)	04-Keyboard try for ED of Sustainability (Shawn Miva)'s desk	03/15/2024	74.99
--	--	------------	-------

Account 52110 - Office Supplies Totals	Invoice 1	\$74.99
---	-----------	---------

Transactions	
--------------	--

Account **53160 - Instruction**

2940 - Ball State University	04: 2024 Indiana Economic Development Court - Chaz Mottinaer	03/15/2024	745.00
8395 - McKaylyn Lynch	04-reimb-parking/Conf Fee-Sustainability Conf-Indy-2/9/24	03/15/2024	50.00
13383 - Shawn Christie Miya	04-reimb pkg/conf fee-Sustainability Conf-Indy-2/9/24	03/15/2024	50.00
8368 - Holly Warren	004-Reim per diem/pkg-College Art Assoc- Chicago-2/13-2/17/24	03/15/2024	439.94

Account 53160 - Instruction Totals	Invoice 4	\$1,284.94
---	-----------	------------

Transactions	
--------------	--



Board of Public Works Claim Register

Invoice Date Range 03/02/24 - 03/15/24

Account **53230 - Travel**

8395 - McKaylyn Lynch	04-reimb-parking/Conf Fee-Sustainability Conf-Indy-2/9/24	03/15/2024	11.00
13383 - Shawn Christie Miya	04-reimb pkg/conf fee-Sustainability Conf-Indy-2/9/24	03/15/2024	11.00
Account 53230 - Travel Totals		Invoice 2	\$22.00
		Transactions	

Account **53310 - Printing**

3892 - Midwest Color Printing, INC	04-250 Business Cards for Warren & Kupersmith INV 20323	03/15/2024	130.28
3892 - Midwest Color Printing, INC	04-250 Business Cards for De del a Rosa	03/15/2024	64.83
Account 53310 - Printing Totals		Invoice 2	\$195.11
		Transactions	
Program 040000 - Main Totals		Invoice 9	\$1,577.04
		Transactions	

Program **04TECH - Trades Tech Center**

Account **53990 - Other Services and Charges**

18844 - First Financial Bank, N.A.	04-Harrell-Fish (HFI) Escrow-Tech Ctr-App 4	03/15/2024	254.00
321 - Harrell Fish, INC (HFI)	04-Mechanical Contractor Work-Tech Ctr-Proj 004307--App 4	03/15/2024	4,826.00
595 - Weddle Bros Construction Co., INC	04-Trades District Tech Ctr Management - Pay App #7	03/15/2024	43,931.13
Account 53990 - Other Services and Charges Totals		Invoice 3	\$49,011.13
		Transactions	
Program 04TECH - Trades Tech Center Totals		Invoice 3	\$49,011.13
		Transactions	
Department 04 - Economic & Sustainable Dev Totals		Invoice 12	\$50,588.17
		Transactions	

Department **05 - Common Council**

Program **050000 - Main**

Account **52110 - Office Supplies**

3560 - First Financial Bank / Credit Cards	05-Namify-Nametags for City Council members	03/15/2024	71.66
3892 - Midwest Color Printing, INC	05 - Business cards for City Council members	03/15/2024	324.15
Account 52110 - Office Supplies Totals		Invoice 2	\$395.81
		Transactions	



Board of Public Works Claim Register

Invoice Date Range 03/02/24 - 03/15/24

<p>Program 050000 - Main Totals</p> <p>Department 05 - Common Council Totals</p>		<p>Invoice 2</p> <p>Transactions</p> <p>Invoice 2</p> <p>Transactions</p>	<p><u>\$395.81</u></p> <p><u>\$395.81</u></p>
<p>Department 06 - Controller's Office</p> <p>Program 060000 - Main</p> <p>Account 52420 - Other Supplies</p>			
8541 - Amazon.com Sales, INC (Amazon.com Services LLC)	06-Logitech MK850 Wireless Keyboard and Mouse Combo (A Watts)	03/15/2024	79.99
6222 - Apple, INC	06-Ipads (2) and accessor: C. Gilland for cash auditing purpose	03/15/2024	1,555.90
371 - Pitney Bowes, INC	06- Mail Machine Connect+ Red Ink cartridge #787-0 (2)	03/15/2024	259.10
<p>Account 52420 - Other Supplies Totals</p>		<p>Invoice 3</p> <p>Transactions</p>	<p><u>\$1,894.99</u></p>
<p>Account 53730 - Machinery and Equipment Rental</p>			
371 - Pitney Bowes, INC	06-Mail Meter Rental Dec 1, 2022 - Jul 25, 2023-old machine	03/15/2024	364.40
<p>Account 53730 - Machinery and Equipment Rental Totals</p>		<p>Invoice 1</p> <p>Transactions</p>	<p><u>\$364.40</u></p>
<p>Account 53910 - Dues and Subscriptions</p>			
8541 - Amazon.com Sales, INC (Amazon.com Services LLC)	06-Amazon Business Prime membership 2024	03/15/2024	1,299.00
<p>Account 53910 - Dues and Subscriptions Totals</p> <p>Program 060000 - Main Totals</p> <p>Department 06 - Controller's Office Totals</p>		<p>Invoice 1</p> <p>Transactions</p> <p>Invoice 5</p> <p>Transactions</p> <p>Invoice 5</p> <p>Transactions</p>	<p><u>\$1,299.00</u></p> <p><u>\$3,558.39</u></p> <p><u>\$3,558.39</u></p>
<p>Department 07 - Engineering</p> <p>Program 070000 - Main</p> <p>Account 52110 - Office Supplies</p>			
6530 - Office Depot, INC	07-Notebooks	03/15/2024	7.75
6530 - Office Depot, INC	07-Scissors, Labels, Sticky notes	03/15/2024	36.81
<p>Account 52110 - Office Supplies Totals</p>		<p>Invoice 2</p> <p>Transactions</p>	<p><u>\$44.56</u></p>



Board of Public Works Claim Register

Invoice Date Range 03/02/24 - 03/15/24

Account 52420 - Other Supplies

53442 - Paragon Micro, INC

07-Dell laptop battery replacement (J. Inman's) 03/15/2024 151.99

Account **52420 - Other Supplies** Totals Invoice 1 \$151.99
Transactions

Account 52430 - Uniforms and Tools

798 - Winters Associates Promotional Products, INC

07-11 Quarter Zip Jackets Engineering Employees 03/15/2024 746.00

Account **52430 - Uniforms and Tools** Totals Invoice 1 \$746.00
Transactions

Account 53230 - Travel

3560 - First Financial Bank / Credit Cards

07-PU Parking Services R. Aten-Road School-Parking 03/15/2024 10.00
3/12-3/13/24

Account **53230 - Travel** Totals Invoice 1 \$10.00
Transactions

Account 53240 - Freight / Other

798 - Winters Associates Promotional Products, INC

07-11 Quarter Zip Jackets Engineering Employees 03/15/2024 13.88

Account **53240 - Freight / Other** Totals Invoice 1 \$13.88
Transactions

Account 53310 - Printing

3892 - Midwest Color Printing, INC

07-250 Business cards (J. Inman) 03/15/2024 64.83

Account **53310 - Printing** Totals Invoice 1 \$64.83
Transactions

Account 53320 - Advertising

3560 - First Financial Bank / Credit Cards

07-ITE Career Center ad for new Traffic Engineer 03/15/2024 345.00
Position

Account **53320 - Advertising** Totals Invoice 1 \$345.00
Transactions

Account 53910 - Dues and Subscriptions

3560 - First Financial Bank / Credit Cards

07-doxpop Subscription Access to Public Records 03/15/2024 15.00
2/13

Account **53910 - Dues and Subscriptions** Totals Invoice 1 \$15.00
Transactions

Account 53990 - Other Services and Charges

409 - Black Lumber Co. INC

07-Materials-New PM & Traffic Eng offices , drywall 03/15/2024 91.14



Board of Public Works Claim Register

Invoice Date Range 03/02/24 - 03/15/24

409 - Black Lumber Co. INC	07-Materials-New PM & Traffic Eng Off-drywall, corner bead	03/15/2024	110.69
2128 - Van Ausdall & Farrar, INC	07-Scan/Convert archived Files to digital (OnBase)-11/30/23	03/15/2024	7,559.85
2128 - Van Ausdall & Farrar, INC	07-Scan/Convert archived Files to digital (OnBase)-12/31/23	03/15/2024	2,042.04
Account 53990 - Other Services and Charges Totals		Invoice 4	<u>\$9,803.72</u>
Program 070000 - Main Totals		Transactions Invoice 13	<u>\$11,194.98</u>
Department 07 - Engineering Totals		Transactions Invoice 13	<u>\$11,194.98</u>
		Transactions	

Department **09 - CFRD**

Program **090000 - Main**

Account **52420 - Other Supplies**

3560 - First Financial Bank / Credit Cards	09-Notary Journal, Stamp, Embosser-Ximena Martinez	03/15/2024	83.67
3560 - First Financial Bank / Credit Cards	09-Dry Cleaning of Event Table Cloths-7 items	03/15/2024	83.25
Account 52420 - Other Supplies Totals		Invoice 2	<u>\$166.92</u>
		Transactions	

Account **53310 - Printing**

3892 - Midwest Color Printing, INC	09-C Culp Ambassador Program Manager Business Cards- 250 ct	03/15/2024	65.13
Account 53310 - Printing Totals		Invoice 1	<u>\$65.13</u>
		Transactions	

Account **53910 - Dues and Subscriptions**

3560 - First Financial Bank / Credit Cards	09-Constant Contact Sub-Monthly-2/27/24	03/15/2024	145.00
54182 - Sister Cities International	09-City of Bloomington, IN Sister Cities Intl. Dues for 2024	03/15/2024	810.00
Account 53910 - Dues and Subscriptions Totals		Invoice 2	<u>\$955.00</u>
Program 090000 - Main Totals		Transactions Invoice 5	<u>\$1,187.05</u>
Department 09 - CFRD Totals		Transactions Invoice 5	<u>\$1,187.05</u>
		Transactions	

Department **10 - Legal**

Program **100000 - Main**



Board of Public Works Claim Register

Invoice Date Range 03/02/24 - 03/15/24

Account 53120 - Special Legal Services

19660 - Bose McKinney & Evans, LLP	10- legal services- Annexation Remonstrances-Jan 2024	03/15/2024	33,326.22
19660 - Bose McKinney & Evans, LLP	10-BME legal services Waldren Arts center-1/10-1/12/24	03/15/2024	86.00
	Account 53120 - Special Legal Services Totals	Invoice 2 Transactions	<u>\$33,412.22</u>

Account 53160 - Instruction

3560 - First Financial Bank / Credit Cards	10-training Brittingham Trial Lawyers-Brittingham-3/25/24	03/15/2024	125.00
	Account 53160 - Instruction Totals	Invoice 1 Transactions	<u>\$125.00</u>

Account 53910 - Dues and Subscriptions

7712 - Indiana Municipal Lawyers Assoc., INC (IMLA)	10-IMLA dues 2024 Rice, Allen, Brittingham, Lacy, Wheeler. Pratt	03/15/2024	510.00
	Account 53910 - Dues and Subscriptions Totals	Invoice 1 Transactions	<u>\$510.00</u>
	Program 100000 - Main Totals	Invoice 4 Transactions	<u>\$34,047.22</u>
	Department 10 - Legal Totals	Invoice 4 Transactions	<u>\$34,047.22</u>

Department 11 - Mayor's Office

Program 110000 - Main

Account 52110 - Office Supplies

3892 - Midwest Color Printing, INC	11-250 business card for Mayor and Deputy Mayor	03/15/2024	129.66
6530 - Office Depot, INC	11 - parchment paper and tissues	03/15/2024	62.42
	Account 52110 - Office Supplies Totals	Invoice 2 Transactions	<u>\$192.08</u>

Account 52420 - Other Supplies

3560 - First Financial Bank / Credit Cards	11 -Namify; Name Badges-2/1/24	03/15/2024	567.54
	Account 52420 - Other Supplies Totals	Invoice 1 Transactions	<u>\$567.54</u>

Account 53170 - Mgt. Fee, Consultants, and Workshops

3560 - First Financial Bank / Credit Cards	11 -The Aspen Institute Conference-Mayor Thomson-3/11-3/13/24	03/15/2024	1,000.00
--	---	------------	----------



Board of Public Works Claim Register

Invoice Date Range 03/02/24 - 03/15/24

Account 53170 - Mgt. Fee, Consultants, and Workshops Totals		Invoice 1	\$1,000.00
		Transactions	
Account 53630 - Machinery and Equipment Repairs			
5120 - Gordon Flesch Company, INC	11 - fixing jammed printer 02/07/24	03/15/2024	475.30
Account 53630 - Machinery and Equipment Repairs Totals		Invoice 1	\$475.30
		Transactions	
Account 53910 - Dues and Subscriptions			
3560 - First Financial Bank / Credit Cards	11 -Grammarly OOTM Yearly 2024	03/15/2024	540.00
175 - Monroe County Humane Association, INC	11-Tails on the Town Sponsorship	03/15/2024	500.00
Account 53910 - Dues and Subscriptions Totals		Invoice 2	\$1,040.00
		Transactions	
Account 53990 - Other Services and Charges			
3560 - First Financial Bank / Credit Cards	11 -Sendinblue digital newsletter platform-1/30-2/29/24	03/15/2024	181.00
3560 - First Financial Bank / Credit Cards	11 -Namify; Name Badges-2/9/24	03/15/2024	91.26
3560 - First Financial Bank / Credit Cards	11 -Namify; Name Badges-2/16/24	03/15/2024	301.75
3560 - First Financial Bank / Credit Cards	11 -Namify; Name Badges-2/16/24	03/15/2024	198.45
3560 - First Financial Bank / Credit Cards	11 -Namify; Name Badges-credit-2/20/24	03/15/2024	(9.41)
Account 53990 - Other Services and Charges Totals		Invoice 5	\$763.05
		Transactions	
Program 110000 - Main Totals		Invoice 12	\$4,037.97
		Transactions	
Department 11 - Mayor's Office Totals		Invoice 12	\$4,037.97
		Transactions	
Department 12 - Human Resources			
Program 120000 - Main			
Account 52420 - Other Supplies			
8541 - Amazon.com Sales, INC (Amazon.com Services LLC)	12- cell phone accessories-phone case, charger - S Johnson	03/15/2024	55.94
Account 52420 - Other Supplies Totals		Invoice 1	\$55.94
		Transactions	
Account 53320 - Advertising			



Board of Public Works Claim Register

Invoice Date Range 03/02/24 - 03/15/24

3560 - First Financial Bank / Credit Cards	12-Linkedin Job Posting Slots	03/15/2024	3,820.00
3560 - First Financial Bank / Credit Cards	12-SCIHRA-HR Asst Director Job Posting	03/15/2024	50.00
	Account 53320 - Advertising Totals	Invoice 2 Transactions	<u>\$3,870.00</u>
Account 53910 - Dues and Subscriptions			
3560 - First Financial Bank / Credit Cards	12-SCIHRA Membership for Scales, Mevis, and Allen	03/15/2024	435.00
3560 - First Financial Bank / Credit Cards	12-2024 Aim IMPACT Dues	03/15/2024	50.00
	Account 53910 - Dues and Subscriptions Totals	Invoice 2 Transactions	<u>\$485.00</u>
Account 53990 - Other Services and Charges			
8882 - Employers Choice Online INC	12-out of state background checks (15)-2/29/2024	03/15/2024	763.48
3892 - Midwest Color Printing, INC	12-S Pechac 250 business cards	03/15/2024	64.83
	Account 53990 - Other Services and Charges Totals	Invoice 2 Transactions	<u>\$828.31</u>
	Program 120000 - Main Totals	Invoice 7 Transactions	<u>\$5,239.25</u>
	Department 12 - Human Resources Totals	Invoice 7 Transactions	<u>\$5,239.25</u>
Department 13 - Planning			
Program 130000 - Main			
Account 42080 - F.H.W.A. Planning			
199 - Monroe County Government	13- FY 2024 UPWP Q2 Infrastructure Management Svstems	03/15/2024	6,096.56
	Account 42080 - F.H.W.A. Planning Totals	Invoice 1 Transactions	<u>\$6,096.56</u>
Account 43310 - Application Fee			
Amber Rentals	13-Petitioner no longer process-CU-01-24-516 Ealeson	03/15/2024	250.00
	Account 43310 - Application Fee Totals	Invoice 1 Transactions	<u>\$250.00</u>
Account 52110 - Office Supplies			
5099 - Office Three Sixty, INC	13- Paper Towels	03/15/2024	26.98



Board of Public Works Claim Register

Invoice Date Range 03/02/24 - 03/15/24

Account 52110 - Office Supplies Totals		Invoice 1	\$26.98
		Transactions	
Account 52420 - Other Supplies	13- New 22" Computer Monitor for Jennifer Burrell	03/15/2024	189.99
53442 - Paragon Micro, INC	13- Office Chair for Ryan Robling	03/15/2024	149.99
5103 - Staples Contract & Commercial, INC	Account 52420 - Other Supplies Totals		\$339.98
		Invoice 2	
		Transactions	
Account 53160 - Instruction	13- APA Planning Conference Registration-Jennifer Burrell	03/15/2024	829.00
3560 - First Financial Bank / Credit Cards	Account 53160 - Instruction Totals		\$829.00
		Invoice 1	
		Transactions	
Account 53230 - Travel	13-Hotel Reservation for Jennifer Burrell for NPC24	03/15/2024	744.92
3560 - First Financial Bank / Credit Cards	Account 53230 - Travel Totals		\$744.92
		Invoice 1	
		Transactions	
Account 53310 - Printing	13-250 Business Cards for Karina Pazos	03/15/2024	65.13
3892 - Midwest Color Printing, INC	Account 53310 - Printing Totals		\$65.13
		Invoice 1	
		Transactions	
Account 53910 - Dues and Subscriptions	13- APA Membership Renewal for Karina Pazos	03/15/2024	358.00
3560 - First Financial Bank / Credit Cards	Account 53910 - Dues and Subscriptions Totals		\$358.00
		Invoice 1	
		Transactions	
Account 53990 - Other Services and Charges	13- APA Membership for Jennifer Burrell	03/15/2024	115.08
3560 - First Financial Bank / Credit Cards	13-Safe Streets & Roads for All Action Plan-thru 01/26/24	03/15/2024	8,720.84
6235 - Toole Design Group, LLC	Account 53990 - Other Services and Charges Totals		\$8,835.92
		Invoice 2	
		Transactions	
Program 130000 - Main Totals		Invoice 11	\$17,546.49
		Transactions	
Program 132000 - MPO			



Board of Public Works Claim Register

Invoice Date Range 03/02/24 - 03/15/24

Account **53990 - Other Services and Charges**

3414 - Burgess & Niple, INC	13- BMCMPO 2050 Transportation Plan 01/01/24-01/31/24	BC 2023-082	03/15/2024	4,000.00
Account 53990 - Other Services and Charges Totals				Invoice 1
				Transactions
Program 132000 - MPO Totals				Invoice 1
				Transactions
Department 13 - Planning Totals				Invoice 12
				Transactions
				\$21,546.49

Department **19 - Facilities Maintenance**

Program **190000 - Main**

Account **52310 - Building Materials and Supplies**

8541 - Amazon.com Sales, INC (Amazon.com Services LLC)	19 - 3pk watersentry plus filters, drum wrench, barrel pump		03/15/2024	323.05
409 - Black Lumber Co. INC	19 - Sandpaper, pry bars, drywall tools		03/15/2024	47.40
409 - Black Lumber Co. INC	19 - Drill & staples		03/15/2024	207.91
409 - Black Lumber Co. INC	19 - 1 - 1x6x16 primed pine lumber		03/15/2024	26.99
413 - Bloomington Paint & Wallpaper Co	19 - grit sanding disk & medium angled paint		03/15/2024	14.88
293 - J&S Locksmith Shop, INC	19 - pro trimmer line		03/15/2024	92.99
4574 - John Deere Financial f.s.b. (Rural King)	19 - Safety boots (1-13W), (1-14M)		03/15/2024	249.90
8658 - Kleindorfer's Hardware LLC	19 - connectors, extension cord, bushings, cable, screws, wrench		03/15/2024	177.85
Account 52310 - Building Materials and Supplies Totals				Invoice 8
				Transactions
				\$1,140.97

Account **52430 - Uniforms and Tools**

19171 - Aramark Uniform & Career Apparel Group, INC	19 - pants for R. Flake - 2/15/24		03/15/2024	12.41
19171 - Aramark Uniform & Career Apparel Group, INC	19 - Pants for R. Flake - 2/22/24		03/15/2024	12.41
Account 52430 - Uniforms and Tools Totals				Invoice 2
				Transactions
				\$24.82

Account **53160 - Instruction**

9183 - RainFocus, LLC	02-Trimble/Cityworks Conf Fee-Nickel/Boruff/Stephens/Bowlen		03/15/2024	720.00
-----------------------	---	--	------------	--------



Board of Public Works Claim Register

Invoice Date Range 03/02/24 - 03/15/24

		Account 53160 - Instruction Totals	Invoice 1 Transactions	<u>\$720.00</u>
Account 53610 - Building Repairs				
1420 - Richard Trinkle (Trinkle SnowPlowing LLC)	19 - SA snow removal for City Hall-East Side -1/13 & BC 2023-113	1/14/24	03/15/2024	600.00
1420 - Richard Trinkle (Trinkle SnowPlowing LLC)	19 - SA snow removal for City Hall 2/16/24		BC 2023-113 03/15/2024	150.00
		Account 53610 - Building Repairs Totals	Invoice 2 Transactions	<u>\$750.00</u>
		Program 190000 - Main Totals	Invoice 13 Transactions	<u>\$2,635.79</u>
		Department 19 - Facilities Maintenance Totals	Invoice 13 Transactions	<u>\$2,635.79</u>
Department 28 - ITS				
Program 280000 - Main				
Account 52110 - Office Supplies				
6530 - Office Depot, INC	28-2024 Copy Paper Supply at Shower Building-10 cases		03/15/2024	384.00
		Account 52110 - Office Supplies Totals	Invoice 1 Transactions	<u>\$384.00</u>
Account 52420 - Other Supplies				
8541 - Amazon.com Sales, INC (Amazon.com Services LLC)	28-2 External Hard Drives for TSG Team		03/15/2024	59.98
		Account 52420 - Other Supplies Totals	Invoice 1 Transactions	<u>\$59.98</u>
Account 53160 - Instruction				
205 - City Of Bloomington	28- 2024 Women's History Month Luncheon Ticket - Jones		03/15/2024	35.00
5444 - Tyler Technologies, INC	28-Tyler Connect Full Conference Package-Schneider		03/15/2024	1,199.00
5444 - Tyler Technologies, INC	28-Tyler Connect Full Conference Package for Overtoom		03/15/2024	1,199.00
		Account 53160 - Instruction Totals	Invoice 3 Transactions	<u>\$2,433.00</u>
Account 53230 - Travel				
3560 - First Financial Bank / Credit Cards	28-2024 Digital Inclusion Conf-Hotel-PA-Brader-2/12-2/16/24		03/15/2024	1,021.66
		Account 53230 - Travel Totals	Invoice 1 Transactions	<u>\$1,021.66</u>



Board of Public Works Claim Register

Invoice Date Range 03/02/24 - 03/15/24

Account 53640 - Hardware and Software Maintenance

3989 - Ricoh USA, INC	28- City Civil Copier/Printer Maintenance 01/17/24-02/16/24	03/15/2024	218.66
3989 - Ricoh USA, INC	28 -City Civil Copier/Printer Maintenance 01/17/24-02/16/24	03/15/2024	2,455.14
8750 - Service Express, INC	28-Maintenance For Legacy Switches 02/29/24	03/15/2024	1,182.00
5444 - Tyler Technologies, INC	28- Citizen Transparency Portal (City 1/2)	03/15/2024	9,121.55

Account **53640 - Hardware and Software Maintenance** Totals Invoice 4 Transactions \$12,977.35

Account 53910 - Dues and Subscriptions

3560 - First Financial Bank / Credit Cards	28- Basecamp - Annual Renewal 2/27/24--2/27/25	03/15/2024	1,200.00
3560 - First Financial Bank / Credit Cards	28-BlueSky - Zoom Timer Subscription 02/04/24	03/15/2024	89.95
3560 - First Financial Bank / Credit Cards	28- Canva Subscriptions 02/26/24	03/15/2024	44.29
3560 - First Financial Bank / Credit Cards	28-Google - Website & Application APIs & Dom Jan 2024	03/15/2024	74.18
3560 - First Financial Bank / Credit Cards	28- Submittable - Application Sub Software 02/27-03/27/24	03/15/2024	119.00
3560 - First Financial Bank / Credit Cards	28-Zoom - Subscriptions & Storage Fees 02/20/24-03/19/24	03/15/2024	430.00
3560 - First Financial Bank / Credit Cards	28- Airtable - Subscription 2024 02/23/24-02/23-25	03/15/2024	2,194.27
8441 - Promevo Holdings, INC (Promevo, LLC)	28-Annual Google Enterprise Standard lic-ITS-1/26/24-1/26/25	03/15/2024	133,560.00
2895 - Rapid Reproductions, INC	28-Planroom Renewal 3-15-24 to 3-14-25	03/15/2024	1,680.00

Account **53910 - Dues and Subscriptions** Totals Invoice 9 Transactions \$139,391.69

Account 54420 - Purchase of Equipment

5534 - Presidio Holdings, INC	28-Seminary Park Wi-Fi - Exterior Box & AP Deployment	03/15/2024	4,847.24
5534 - Presidio Holdings, INC	28- Seminary Park Wi-Fi - Exterior Box & AP Deployment	03/15/2024	655.63

Account **54420 - Purchase of Equipment** Totals Invoice 2 Transactions \$5,502.87

Program **280000 - Main** Totals Invoice 21 Transactions \$161,770.55

Department **28 - ITS** Totals Invoice 21 Transactions \$161,770.55



Board of Public Works Claim Register

Invoice Date Range 03/02/24 - 03/15/24

Fund **103 - Restricted Donations(ord 05-17)**

Department **06 - Controller's Office**

Program **400101 - Animal Medical Services**

Account **53130 - Medical**

50350 - Arlington Heights Veterinary Hospital, INC

50350 - Arlington Heights Veterinary Hospital, INC

01 - dental surgery and amputation/spay/neuter-10/3/23 & 2/27/24	03/15/2024	783.41
01 - spay/neuter surgery-10/13/2023	03/15/2024	60.00

Account **53130 - Medical** Totals

Invoice 175
Transactions \$312,088.98

Invoice 2 \$843.41
Transactions
Invoice 2 \$843.41
Transactions

Program **400101 - Animal Medical Services** Totals

Program **400102 - Animal Supplies**

Account **52210 - Institutional Supplies**

3278 - Boehringer Ingelheim Animal Health (Merial, INC)

01-Insulin	03/15/2024	175.52
------------	------------	--------

Account **52210 - Institutional Supplies** Totals

Invoice 1 \$175.52
Transactions

Program **400102 - Animal Supplies** Totals

Invoice 1 \$175.52
Transactions

Department **06 - Controller's Office** Totals

Invoice 3 \$1,018.93
Transactions

Fund **103 - Restricted Donations(ord 05-17)** Totals

Invoice 3 \$1,018.93
Transactions

Fund **153 - LIT – Economic Development**

Department **04 - Economic & Sustainable Dev**

Program **040000 - Main**

Account **53960 - Grants**

9063 - Donovan Energy

3404 - J.R. Watkins & Family, INC (Signs Now)

04-Municipal Energy Efficiency & Decarbonization Proi Mamt-2/23	03/15/2024	12,350.00
04-Printing Services - Earth Day Posters - reprint	03/15/2024	456.00

Account **53960 - Grants** Totals

Invoice 2 \$12,806.00
Transactions



Board of Public Works Claim Register

Invoice Date Range 03/02/24 - 03/15/24

Department **12 - Human Resources**
 Program **120000 - Main**
 Account **53990 - Other Services and Charges**

Program **040000 - Main** Totals
 Department **04 - Economic & Sustainable Dev** Totals

Invoice 2	\$12,806.00
Transactions	
Invoice 2	\$12,806.00
Transactions	

3560 - First Financial Bank / Credit Cards

12-Black Expo Career Fair Vendor Booth-S. Johnson	03/15/2024	725.00
---	------------	--------

Account **53990 - Other Services and Charges** Totals

Invoice 1	\$725.00
Transactions	
Invoice 1	\$725.00
Transactions	

Program **120000 - Main** Totals

Department **12 - Human Resources** Totals

Invoice 1	\$725.00
Transactions	
Invoice 1	\$725.00
Transactions	

Department **19 - Facilities Maintenance**

Program **190000 - Main**

Account **53610 - Building Repairs**

6688 - SSW Enterprises, LLC (Office Pride)
 6688 - SSW Enterprises, LLC (Office Pride)
 6688 - SSW Enterprises, LLC (Office Pride)
 6688 - SSW Enterprises, LLC (Office Pride)
 6688 - SSW Enterprises, LLC (Office Pride)

19-Cleaning Services-ACC-February 2024	03/15/2024	1,789.60
19-Cleaning Services-City Hall-February 2024	03/15/2024	13,658.40
19-Cleaning Services-Fleet Maintenance-February 2024	03/15/2024	1,072.89
19-Cleaning Services-Street & Traffic Bldgs-February 2024	03/15/2024	1,666.56
19-Cleaning Services-Sanitation-February 2024	03/15/2024	939.36

Account **53610 - Building Repairs** Totals

Invoice 5	\$19,126.81
Transactions	

Account **53990 - Other Services and Charges**

421 - Centerstone Of Indiana, INC
 421 - Centerstone Of Indiana, INC

02-Brighten B-Town Program Jan 2024	BC 2023-096	03/15/2024	30,307.39
02-Brighten B-Town Program-Jan 2024 Vehicle Lease	BC 2023-096	03/15/2024	649.00

Account **53990 - Other Services and Charges** Totals

Invoice 2	\$30,956.39
Transactions	
Invoice 7	\$50,083.20
Transactions	

Program **190000 - Main** Totals

Invoice 2	\$30,956.39
Transactions	
Invoice 7	\$50,083.20
Transactions	



Board of Public Works Claim Register

Invoice Date Range 03/02/24 - 03/15/24

Fund 163 - Opioid Settlement Restricted

Department **09 - CFRD**

Program **090000 - Main**

Account **53990 - Other Services and Charges**

8541 - Amazon.com Sales, INC (Amazon.com Services LLC)

Department **19 - Facilities Maintenance** Totals

Fund **153 - LIT – Economic Development** Totals

Invoice 7	\$50,083.20
Transactions	
Invoice 10	\$63,614.20
Transactions	

09-200 Face Shields-NARCAN Behind Every Bar Project 2024	03/15/2024	140.00
Account 53990 - Other Services and Charges Totals	Invoice 1	\$140.00
	Transactions	
Program 090000 - Main Totals	Invoice 1	\$140.00
	Transactions	
Department 09 - CFRD Totals	Invoice 1	\$140.00
	Transactions	
Fund 163 - Opioid Settlement Restricted Totals	Invoice 1	\$140.00
	Transactions	

Fund 176 - ARPA Local Fiscal Recvry (S9512)

Department **04 - Economic & Sustainable Dev**

Program **G21005 - ARPA COVID Local Fiscal Recovery**

Account **53960 - Grants**

13433 - Cardinal Stage Company, INC

7532 - Christina Elem

8530 - Elise Adele Putnam

04-2023-2024 Visual Arts Grant-1st draw-7/1-12/31/23	03/15/2024	11,097.28
04-Consulting Services for public art-1/23-2/28/24	03/15/2024	1,072.00
04-COB Arts Storefront Initiative-12/19/23-02/15/24	03/15/2024	870.00
Account 53960 - Grants Totals	Invoice 3	\$13,039.28
	Transactions	
Program G21005 - ARPA COVID Local Fiscal Recovery Totals	Invoice 3	\$13,039.28
	Transactions	
Department 04 - Economic & Sustainable Dev Totals	Invoice 3	\$13,039.28
	Transactions	
Fund 176 - ARPA Local Fiscal Recvry (S9512) Totals	Invoice 3	\$13,039.28
	Transactions	

Fund 312 - Community Services



Board of Public Works Claim Register

Invoice Date Range 03/02/24 - 03/15/24

Department **09 - CFRD**

Program **090016 - Com Serv - Safe & Civil**

Account **52420 - Other Supplies**

3560 - First Financial Bank / Credit Cards	09-Office Depot-Programs for Black History Month Gala 2024-250ct	03/15/2024	234.50
6284 - VTG Enterprises, LLC (PopKorn)	09-400 bags of Popkorn-4 Flavors-Black History Month Gala 2024	03/15/2024	1,125.00
Account 52420 - Other Supplies Totals		Invoice 2	\$1,359.50
		Transactions	

Account **53910 - Dues and Subscriptions**

3560 - First Financial Bank / Credit Cards	09-Quetext-AI Detection & Plaigerism-Black History Essavs-3	03/15/2024	53.94
Account 53910 - Dues and Subscriptions Totals		Invoice 1	\$53.94
		Transactions	

Account **53990 - Other Services and Charges**

3560 - First Financial Bank / Credit Cards	09-Safe & Civil City Jotform Sub-Moss-2/23-3/23/24	03/15/2024	19.00
3560 - First Financial Bank / Credit Cards	09-Reimbursement for Sales Tax on Elfsight Subscription-Feb 2024	03/15/2024	(1.57)
8369 - Ramon Jackson	09-Performance at Black History Month Gala-R. Jackson & Brides	03/15/2024	2,500.00
Account 53990 - Other Services and Charges Totals		Invoice 3	\$2,517.43
		Transactions	
Program 090016 - Com Serv - Safe & Civil Totals		Invoice 6	\$3,930.87
		Transactions	
Department 09 - CFRD Totals		Invoice 6	\$3,930.87
		Transactions	
Fund 312 - Community Services Totals		Invoice 6	\$3,930.87
		Transactions	

Fund **401 - Non-Reverting Telecom (S1146)**

Department **25 - Telecommunications**

Program **254000 - Infrastructure**

Account **53750 - Rentals - Other**

12283 - Smithville Communications	25 - Smithville - Internet March 2024	03/06/2024	3,214.27
Account 53750 - Rentals - Other Totals		Invoice 1	\$3,214.27
		Transactions	



Board of Public Works Claim Register

Invoice Date Range 03/02/24 - 03/15/24

Program 254000 - Infrastructure Totals		Invoice 1 Transactions	<u>\$3,214.27</u>
Program 256000 - Services			
Account 53150 - Communications Contract			
203 - INDIANA UNIVERSITY	25- Fire Station Dark Fiber Service Nov 2023	03/15/2024	65.00
203 - INDIANA UNIVERSITY	25- Fire Station Dark Fiber Service Feb 2024	03/15/2024	65.00
12283 - Smithville Communications	25 - Smithville - Internet March 2024	03/06/2024	1,415.00
4170 - Comcast Cable Communications, INC	25 - Comcast Internet - 401 N Morton-March 2024	03/06/2024	213.40
4170 - Comcast Cable Communications, INC	28 - 3550 N. Kinser Cascades Clubhouse-02/27/24-03/26/24	03/06/2024	110.35
Account 53150 - Communications Contract Totals		Invoice 5 Transactions	<u>\$1,868.75</u>
Account 54450 - Equipment			
53442 - Paragon Micro, INC	28- CAPR Monitor for OOTM	03/15/2024	1,089.99
53442 - Paragon Micro, INC	28- CAPR Printer for Parks	03/15/2024	2,489.99
53442 - Paragon Micro, INC	28 -CAPR 15 UPS City Stock	03/15/2024	1,124.85
53442 - Paragon Micro, INC	28-CAPR Monitor for Fleet	03/15/2024	259.99
Account 54450 - Equipment Totals		Invoice 4 Transactions	<u>\$4,964.82</u>
Program 256000 - Services Totals		Invoice 9 Transactions	<u>\$6,833.57</u>
Department 25 - Telecommunications Totals		Invoice 10 Transactions	<u>\$10,047.84</u>
Fund 401 - Non-Reverting Telecom (S1146) Totals		Invoice 10 Transactions	<u>\$10,047.84</u>
Fund 450 - Local Road and Street(S0706)			
Department 20 - Street			
Program 200000 - Main			
Account 53520 - Street Lights / Traffic Signals			
223 - Duke Energy	02-Street Light (Misc Lights)-01/23/24-02/20/24	03/06/2024	100.31



Board of Public Works Claim Register

Invoice Date Range 03/02/24 - 03/15/24

223 - Duke Energy	02-Street Light (Misc Lights)-01/24/24-02/21/24	03/06/2024	466.33
223 - Duke Energy	02-Street Light (Misc Lights)-01/24/24-02/21/24	03/06/2024	54.14
Account 53520 - Street Lights / Traffic Signals Totals		Invoice 3	<u>\$620.78</u>
Program 200000 - Main Totals		Transactions Invoice 3	<u>\$620.78</u>
Department 20 - Street Totals		Transactions Invoice 3	<u>\$620.78</u>
Fund 450 - Local Road and Street(S0706) Totals		Transactions Invoice 3	<u>\$620.78</u>
Fund 451 - Motor Vehicle Highway(S0708)			
Department 20 - Street			
Program 200000 - Main			
Account 52340 - Other Repairs and Maintenance			
4186 - Carrier & Gable, INC	20-Computer board for rapid flashing beacon @ Walnut/Allen	03/15/2024	674.00
Account 52340 - Other Repairs and Maintenance Totals		Invoice 1	<u>\$674.00</u>
Account 52420 - Other Supplies		Transactions	
409 - Black Lumber Co. INC	20-(2) 2 gal back saver sprayer for paving crew	03/15/2024	53.98
409 - Black Lumber Co. INC	20-Mailbox hardware for damage during snow control	03/15/2024	63.31
409 - Black Lumber Co. INC	20-Return Credit for mailbox hardware (inv #566141)	03/15/2024	(4.00)
8658 - Kleindorfer's Hardware LLC	20-Hoses, nozzles, detail spray and pipe wrench	03/15/2024	150.35
8658 - Kleindorfer's Hardware LLC	20-(6) paper towel, trash bags and spray paint	03/15/2024	67.29
8658 - Kleindorfer's Hardware LLC	20-Supplies for bush hog-grease gun	03/15/2024	22.49
2974 - MacAllister Machinery Co, INC	20-Collars for Milling Machine (12)	03/15/2024	623.52
7516 - Quality Supply & Tool Co INC	20-20-1" x 24" Round Nail Stakes for Concrete	03/15/2024	156.00
1743 - The Home City Ice Company	20-127 7lb bags of Ice for crews 02/22/24	03/15/2024	293.13
Account 52420 - Other Supplies Totals		Invoice 9	<u>\$1,426.07</u>
		Transactions	



Board of Public Works Claim Register

Invoice Date Range 03/02/24 - 03/15/24

Account 53130 - Medical

231 - IU Health OCC Health Services	20-Vaccine Hep B - M. Heagy-1/30/24		03/15/2024	130.00
231 - IU Health OCC Health Services	20-Vaccine Hep B-S. McCoy-1/30/24		03/15/2024	130.00
231 - IU Health OCC Health Services	20-Vaccine Hep B-J. Wahl-1/30/24		03/15/2024	130.00

Account **53130 - Medical** Totals Invoice 3 Transactions \$390.00

Account 53160 - Instruction

9183 - RainFocus, LLC	02-Trimble/Cityworks Conf Fee-Nickel/Boruff/Stephens/Bowlen		03/15/2024	1,440.00
2871 - International Municipal Signal Association (IMSA)	20-Work Zone/TS 1 (Prince, Phipps, Akers, Carroll, Morris)		03/15/2024	5,200.00

Account **53160 - Instruction** Totals Invoice 2 Transactions \$6,640.00

Account 53250 - Pagers

332 - Indiana Paging Network, INC	20-Pagers for Snow Control Crews April 2024		03/15/2024	111.48
-----------------------------------	---	--	------------	--------

Account **53250 - Pagers** Totals Invoice 1 Transactions \$111.48

Account 53610 - Building Repairs

6378 - ANN-KRISS, LLC	20-Materials for sealing Street Bldg roof	BC 2023-064	03/15/2024	4,440.47
-----------------------	---	-------------	------------	----------

Account **53610 - Building Repairs** Totals Invoice 1 Transactions \$4,440.47

Account 53920 - Laundry and Other Sanitation Services

19171 - Aramark Uniform & Career Apparel Group, INC	20-uniform rental (minus payroll ded)-2/21/24		03/15/2024	8.35
19171 - Aramark Uniform & Career Apparel Group, INC	20-mat/towel service-2/21/2024		03/15/2024	38.47

Account **53920 - Laundry and Other Sanitation Services** Totals Invoice 2 Transactions \$46.82

Account 53950 - Landfill

52226 - Hoosier Transfer Station-3140	20-Landfill fees for sweeper dumps 02/08/24		03/15/2024	1,360.58
52226 - Hoosier Transfer Station-3140	20-Landfill fees for sweeper dumps 12/07/23 & 12/13/23		03/15/2024	649.61
6152 - K&S Rolloff, INC	20-Rolloff Services for sweeper debris 02/08/24		03/15/2024	500.00



Board of Public Works Claim Register

Invoice Date Range 03/02/24 - 03/15/24

Account 53950 - Landfill Totals	Invoice 3	\$2,510.19
Program 200000 - Main Totals	Transactions Invoice 22	\$16,239.03
Department 20 - Street Totals	Transactions Invoice 22	\$16,239.03
Fund 451 - Motor Vehicle Highway(S0708) Totals	Transactions Invoice 22	\$16,239.03
Fund 452 - Parking Facilities(S9502)	Transactions	
Department 26 - Parking		
Program 260000 - Main		
Account 52110 - Office Supplies		
53442 - Paragon Micro, INC	26-office printer and scanner-Cox	03/15/2024 352.99
	Account 52110 - Office Supplies Totals	Invoice 1 \$352.99
Account 52310 - Building Materials and Supplies	Transactions	
8541 - Amazon.com Sales, INC (Amazon.com Services LLC)	26-rotary tool case and battery charger for parking services	03/15/2024 41.97
8541 - Amazon.com Sales, INC (Amazon.com Services LLC)	26-rotary tool-blades-recipept rolls-clorox wipes-batteries	03/15/2024 100.11
8658 - Kleindorfer's Hardware LLC	26-Gray spray paint for graffiti in all garages	03/15/2024 27.16
	Account 52310 - Building Materials and Supplies Totals	Invoice 3 \$169.24
Account 52430 - Uniforms and Tools	Transactions	
3588 - Cintas Corporation (Cintas #529 EFT Vendor)	26-new uniforms for garage staff and manager	03/15/2024 311.92
	Account 52430 - Uniforms and Tools Totals	Invoice 1 \$311.92
Account 53610 - Building Repairs	Transactions	
393 - Kone INC	26-Morton St Garage-elevator monthly maintenance- BC 2023-101 Feb 20224	03/15/2024 456.54
	Account 53610 - Building Repairs Totals	Invoice 1 \$456.54
Account 53650 - Other Repairs	Transactions	
1537 - Indiana Door & Hardware Specialties, INC	26-new cores and keys for retail in trades and 4th st BC 2023-076	03/15/2024 376.00



Board of Public Works Claim Register

Invoice Date Range 03/02/24 - 03/15/24

Account 53840 - Lease Payments

512 - 7th & Walnut , LLC

3887 - Mercury Development Group, LLC

Account 53650 - Other Repairs Totals	Invoice 1	<u>\$376.00</u>
	Transactions	
26-Walnut St Garage- April 2024 garage rent	03/15/2024	17,824.79
26-Morton St Garage-April 2024 garage rent	03/15/2024	38,035.85

Account 53840 - Lease Payments Totals	Invoice 2	<u>\$55,860.64</u>
--	-----------	--------------------

Transactions	Invoice 9	<u>\$57,527.33</u>
--------------	-----------	--------------------

Program 260000 - Main Totals	Transactions	Invoice 9	<u>\$57,527.33</u>
-------------------------------------	--------------	-----------	--------------------

Department 26 - Parking Totals	Transactions	Invoice 9	<u>\$57,527.33</u>
---------------------------------------	--------------	-----------	--------------------

Fund 452 - Parking Facilities(S9502) Totals	Transactions	Invoice 9	<u>\$57,527.33</u>
--	--------------	-----------	--------------------

Transactions

Fund 455 - Parking Meter Fund(S2141)

Department **26 - Parking**

Program **260000 - Main**

Account 52110 - Office Supplies

8541 - Amazon.com Sales, INC (Amazon.com Services LLC)

8541 - Amazon.com Sales, INC (Amazon.com Services LLC)

26-refund for desk calendar-no longer available	03/15/2024	(11.00)
26-toners for parking office printer	03/15/2024	235.78

Account 52110 - Office Supplies Totals	Invoice 2	<u>\$224.78</u>
---	-----------	-----------------

Transactions

Account 52340 - Other Repairs and Maintenance

8541 - Amazon.com Sales, INC (Amazon.com Services LLC)

8541 - Amazon.com Sales, INC (Amazon.com Services LLC)

8541 - Amazon.com Sales, INC (Amazon.com Services LLC)

26-rotary tool case and battery charger for parking services	03/15/2024	41.97
26-multi-plier tool for meter repair	03/15/2024	70.18
26-rotary tool-blades-recipept rolls-clorox wipes-batteries	03/15/2024	312.39

Account 52340 - Other Repairs and Maintenance Totals	Invoice 3	<u>\$424.54</u>
---	-----------	-----------------

Transactions

Account 52420 - Other Supplies

8658 - Kleindorfer's Hardware LLC

26-Key rings for meter collection officer	03/15/2024	14.76
---	------------	-------

Account 52420 - Other Supplies Totals	Invoice 1	<u>\$14.76</u>
--	-----------	----------------

Transactions



Board of Public Works Claim Register

Invoice Date Range 03/02/24 - 03/15/24

Account 53990 - Other Services and Charges

4443 - The Sherwin Williams Company

26-yellow paint for no parking areas and curbs on 400 w 7th st	03/15/2024	378.27
Account 53990 - Other Services and Charges Totals	Invoice 1	<u>\$378.27</u>
Program 260000 - Main Totals	Transactions Invoice 7	<u>\$1,042.35</u>
Department 26 - Parking Totals	Transactions Invoice 7	<u>\$1,042.35</u>
Fund 455 - Parking Meter Fund(S2141) Totals	Transactions Invoice 7	<u>\$1,042.35</u>
	Transactions	

Fund 456 - MVH Restricted

Department **20 - Street**

Program **200000 - Main**

Account 53730 - Machinery and Equipment Rental

351 - Young Trucking, INC

20-Truck & Trailer for moving paving equipment 02/09/24	03/15/2024	1,187.50
Account 53730 - Machinery and Equipment Rental Totals	Invoice 1	<u>\$1,187.50</u>
Program 200000 - Main Totals	Transactions Invoice 1	<u>\$1,187.50</u>
Department 20 - Street Totals	Transactions Invoice 1	<u>\$1,187.50</u>
Fund 456 - MVH Restricted Totals	Transactions Invoice 1	<u>\$1,187.50</u>
	Transactions	

Fund 600 - Cumulative Cap Imprv(CIG)(S2379)

Department **02 - Public Works**

Program **020000 - Main**

Account 52330 - Street , Alley, and Sewer Material

365 - Rogers Group, INC	20-#2 Stone-3rd & Patterson- 02/02/24	03/15/2024	330.42
365 - Rogers Group, INC	20-#53 Stone for Street Projects 02/06/24	03/15/2024	92.39
365 - Rogers Group, INC	20-#53 Stone for Street Projects 02/06/24	03/15/2024	123.10
365 - Rogers Group, INC	20-INDOT #11 Stone for Street Projects 02/08/24	03/15/2024	317.53



Board of Public Works Claim Register

Invoice Date Range 03/02/24 - 03/15/24

365 - Rogers Group, INC	20-#2 Stone for Street Projects 11/30/23		03/15/2024	219.08
365 - Rogers Group, INC	20-#53 Stone for Street Projects 01/24/24-01/26/24		03/15/2024	830.73
Account 52330 - Street , Alley, and Sewer Material Totals			Invoice 6	<u>\$1,913.25</u>
Program 020000 - Main Totals			Transactions Invoice 6	<u>\$1,913.25</u>
Department 02 - Public Works Totals			Transactions Invoice 6	<u>\$1,913.25</u>
Fund 600 - Cumulative Cap Imprv(CIG)(S2379) Totals			Transactions Invoice 6	<u>\$1,913.25</u>
			Transactions	

Fund **601 - Cumulative Capital Devlp(S2391)**

Department **02 - Public Works**

Program **020000 - Main**

Account **52330 - Street , Alley, and Sewer Material**

5149 - E&B Paving, INC	20-Asphalt - cold mix for patching 01/24/24	BC 2023-093A	03/15/2024	4,786.25
Account 52330 - Street , Alley, and Sewer Material Totals			Invoice 1	<u>\$4,786.25</u>
			Transactions	

Account **54510 - Other Capital Outlays**

5149 - E&B Paving, INC	20-Escrow CCMG 2023-1 E 3rd St, W Country Club- Escrow Release	CO 2023-19	03/15/2024	5,286.23
5149 - E&B Paving, INC	20-Escrow CCMG 2023-1 E 3rd St-Mitchell/Eagleson- Escrow Release	CO 2023-18	03/15/2024	6,581.73
5149 - E&B Paving, INC	20-Escrow CCMG 2023-1 E 3rd St-Overhill/Mitchell- Escrow Release	CO 2023-17	03/15/2024	36,104.80
Account 54510 - Other Capital Outlays Totals			Invoice 3	<u>\$47,972.76</u>
Program 020000 - Main Totals			Transactions Invoice 4	<u>\$52,759.01</u>
Department 02 - Public Works Totals			Transactions Invoice 4	<u>\$52,759.01</u>
Fund 601 - Cumulative Capital Devlp(S2391) Totals			Transactions Invoice 4	<u>\$52,759.01</u>
			Transactions	

Fund **730 - Solid Waste (S6401)**

Department **16 - Sanitation**

Program **160000 - Main**



Board of Public Works Claim Register

Invoice Date Range 03/02/24 - 03/15/24

Account 52420 - Other Supplies

4574 - John Deere Financial f.s.b. (Rural King) 16-Dewalt 9 gallon 5HP wet/dry Shop Vac 03/15/2024 119.99

Account **52420 - Other Supplies** Totals Invoice 1 Transactions \$119.99

Account 53610 - Building Repairs

392 - Koorsen Fire & Security, INC 16-Quarterly Monitoring from 1/1/23-03/31/23- BC 2023-089 03/15/2024 101.79

392 - Koorsen Fire & Security, INC 16-Quarterly Monitoring from 1/1/24-03/31/24 BC 2023-089 03/15/2024 101.79

Account **53610 - Building Repairs** Totals Invoice 2 Transactions \$203.58

Account 53920 - Laundry and Other Sanitation Services

19171 - Aramark Uniform & Career Apparel Group, INC 16-uniform rental (minus payroll ded)-2/21/24 03/15/2024 6.01

19171 - Aramark Uniform & Career Apparel Group, INC 16-mat/towel service-2/21/24 03/15/2024 26.76

19171 - Aramark Uniform & Career Apparel Group, INC 16-uniform rental (minus payroll ded)-2/28/24 03/15/2024 6.01

19171 - Aramark Uniform & Career Apparel Group, INC 16-mat/towel service-2/28/24 03/15/2024 26.76

Account **53920 - Laundry and Other Sanitation Services** Totals Invoice 4 Transactions \$65.54

Account 53950 - Landfill

52226 - Hoosier Transfer Station-3140 16-Landfill Fees 02/01/24-02/15/24 03/15/2024 13,216.48

52226 - Hoosier Transfer Station-3140 16-Landfill Fees 02/01/24-02/15/24 03/15/2024 960.50

Account **53950 - Landfill** Totals Invoice 2 Transactions \$14,176.98

Program **160000 - Main** Totals Invoice 9 Transactions \$14,566.09

Department **16 - Sanitation** Totals Invoice 9 Transactions \$14,566.09

Fund **730 - Solid Waste (S6401)** Totals Invoice 9 Transactions \$14,566.09

Fund 800 - Risk Management(S0203)

Department 10 - Legal

Program 100000 - Main



Board of Public Works Claim Register

Invoice Date Range 03/02/24 - 03/15/24

Account 52430 - Uniforms and Tools

1448 - Shoe Carnival, INC	10-safety shoes-Hutslar (9.5)-1/8/2024	03/15/2024	100.00
1448 - Shoe Carnival, INC	10-safety shoes-Cassidy (12)-1/22/2024	03/15/2024	79.98
1448 - Shoe Carnival, INC	10-safety shoes-Fuentes (8.5)-1/27/2024	03/15/2024	79.98
1448 - Shoe Carnival, INC	10-safety shoes-Wiltfong (5)-2/11/2024	03/15/2024	100.00
Account 52430 - Uniforms and Tools Totals		Invoice 4	\$359.96
		Transactions	
Program 100000 - Main Totals		Invoice 4	\$359.96
		Transactions	
Department 10 - Legal Totals		Invoice 4	\$359.96
		Transactions	
Fund 800 - Risk Management(S0203) Totals		Invoice 4	\$359.96
		Transactions	

Fund 801 - Health Insurance Trust

Department 12 - Human Resources

Program 120000 - Main

Account 53990 - Other Services and Charges

18539 - Life Insurance Company Of North America	12-March 2024, Bill Ref # 103094_03/05/2024	03/15/2024	3,945.00
8609 - LoCascio Hadden & Dennis, LLC (LHD Benefit Advisor)	12-employer clinic support - March 2024	03/15/2024	2,600.00
Account 53990 - Other Services and Charges Totals		Invoice 2	\$6,545.00
		Transactions	

Account 53990.1201 - Other Services and Charges Health Insurance

3928 - Aim Medical Trust	12-out of scope fees for 2024 Open Enrollment	03/15/2024	5,000.00
Account 53990.1201 - Other Services and Charges Health Insurance Totals		Invoice 1	\$5,000.00
		Transactions	

Account 53990.1278 - Other Services and Charges Disability LTD

18539 - Life Insurance Company Of North America	12-March 2024, Bill Ref # 103094_03/05/2024	03/15/2024	10,580.02
Account 53990.1278 - Other Services and Charges Disability LTD Totals		Invoice 1	\$10,580.02
		Transactions	
Program 120000 - Main Totals		Invoice 4	\$22,125.02
		Transactions	



Board of Public Works Claim Register

Invoice Date Range 03/02/24 - 03/15/24

Department **12 - Human Resources** Totals
 Fund **801 - Health Insurance Trust** Totals

Invoice 4	\$22,125.02
Transactions	
Invoice 4	\$22,125.02
Transactions	

Fund **802 - Fleet Maintenance(\$9500)**

Department **17 - Fleet Maintenance**

Program **170000 - Main**

Account **52230 - Garage and Motor Supplies**

50605 - Bauer Built, INC	17 - scrap tire disposal - 2/23/24		03/15/2024	65.00
50605 - Bauer Built, INC	17 - scrap tire disposal - 2/19/24		03/15/2024	225.00
50605 - Bauer Built, INC	17 - tires for stock-2/23/24		03/15/2024	4,865.56
4693 - Monroe County Tire & Supply, INC	17 - tires for unit 814		03/15/2024	547.48
4693 - Monroe County Tire & Supply, INC	17 - tires for unit 201		03/15/2024	761.00

Account 52230 - Garage and Motor Supplies Totals	Invoice 5	\$6,464.04
	Transactions	

Account **52240 - Fuel and Oil**

613 - Hoosier Penn Oil Company, INC	17 - oil		03/15/2024	551.75
612 - Petroleum Traders Corporation	17 - unleaded fuel (8,001 gallons)- 02/14/2024	BC 2023-105A	03/15/2024	24,658.99
7854 - Premier AG CO-OP, INC (Premier Energy)	17-diesel-PDX4 B5 Clear Winter on Road-7,359 gallons-2/27/24	BC 2023-105B	03/15/2024	25,273.01
7854 - Premier AG CO-OP, INC (Premier Energy)	17-unleaded fuel-8,094 gallons-2/6/24	BC 2023-105B	03/15/2024	24,684.27
7854 - Premier AG CO-OP, INC (Premier Energy)	17-diesel-PDX4 B5 Clear Winter on Road-7,361 gallons-2/7/24	BC 2023-105B	03/15/2024	24,799.95

Account 52240 - Fuel and Oil Totals	Invoice 5	\$99,967.97
	Transactions	

Account **52320 - Motor Vehicle Repair**

4150 - Alexander's LLC	17 - #561 trailer parts		03/15/2024	564.00
6001 - Bernath, LLC (Sealmaster)	17 - #493 controller for unit 493		03/15/2024	797.95
244 - Bloomington Ford, INC	17 - Relay switch for 410		03/15/2024	17.50



Board of Public Works Claim Register

Invoice Date Range 03/02/24 - 03/15/24

244 - Bloomington Ford, INC	17 - Gasket, spark plug, coil assembly ignition for 133	03/15/2024	58.16
244 - Bloomington Ford, INC	17 - TPMS Sensor Kit for 405	03/15/2024	62.72
244 - Bloomington Ford, INC	17 - cap for 844	03/15/2024	63.03
244 - Bloomington Ford, INC	17 - Automatic transmission oil for stock	03/15/2024	90.60
244 - Bloomington Ford, INC	17 - sensor assembly for 844	03/15/2024	99.82
244 - Bloomington Ford, INC	17 - RTD Key for 410	03/15/2024	130.00
244 - Bloomington Ford, INC	17 - Radiator hose for 497	03/15/2024	193.64
244 - Bloomington Ford, INC	17 - Air Cleaner assembly for 814	03/15/2024	296.25
244 - Bloomington Ford, INC	17 - Door lock module for 410	03/15/2024	612.27
244 - Bloomington Ford, INC	17 - ignition coil assembly for 133	03/15/2024	348.54
5792 - Clark Truck Equipment Co., INC	17 - Chain Assy for unit 4241	03/15/2024	3,514.00
8665 - Effingham Crossroads Truck Equipment INC	17-(15) GRA pushlock for unit 431	03/15/2024	126.30
455 - Industrial Service & Supply, INC	17 - F/F O-ring & O-ring for unit 431	03/15/2024	8.16
455 - Industrial Service & Supply, INC	17 - PiranhaFlex, crimp charge, f/f o-ring for unit 523	03/15/2024	56.41
455 - Industrial Service & Supply, INC	17 - Rod wiper, Polyseal, piston seal, o-ring for unit 431	03/15/2024	424.92
796 - Interstate Battery System of Bloomington, INC	17-batteries-MTX-94R/H7	03/15/2024	311.90
796 - Interstate Battery System of Bloomington, INC	17-batteries-31P-MHD, MTP-65HD, MTP-86, MTX-94R/H7	03/15/2024	700.15
796 - Interstate Battery System of Bloomington, INC	17-batteries-31-MHD, MTP-48/H6, MTP-65HD	03/15/2024	888.52
796 - Interstate Battery System of Bloomington, INC	17-batteries-31P-MHD	03/15/2024	1,026.00
293 - J&S Locksmith Shop, INC	17 - #839-HYPR-Oil 500 (quart) (3)	03/15/2024	56.97
4439 - JX Enterprises, INC	17 - credit for returned parts-inv #27350661P	03/15/2024	(52.16)
4439 - JX Enterprises, INC	17 - Reman brake shoe kit for unit 4221	03/15/2024	245.96
4439 - JX Enterprises, INC	17 - Gasket, coolant drain washer for unit 431	03/15/2024	265.10



Board of Public Works Claim Register

Invoice Date Range 03/02/24 - 03/15/24

4439 - JX Enterprises, INC	17 - Core-cooler, gasket oil, drain, washer, o-ring for unit 431	03/15/2024	314.97
4439 - JX Enterprises, INC	17 - Sensor-nitrogen oxide for unit 720	03/15/2024	688.61
53385 - O'Reilly Automotive Stores, INC	17 - 2.5 Gal of BlueDEF for unit 959	03/15/2024	16.99
53385 - O'Reilly Automotive Stores, INC	17 - Trans mount for unit P0127	03/15/2024	59.33
53385 - O'Reilly Automotive Stores, INC	17 - Battery and core charge for shop	03/15/2024	115.23
53385 - O'Reilly Automotive Stores, INC	17 - VVT Solenoid, manifold set, V/C Gasket for P127	03/15/2024	207.33
53385 - O'Reilly Automotive Stores, INC	17 - 4 oil filters for stock	03/15/2024	21.16
53385 - O'Reilly Automotive Stores, INC	17 - Tie rod for unit 1200	03/15/2024	39.23
53385 - O'Reilly Automotive Stores, INC	17 - Belt tensner, micro-v belt for unit 856	03/15/2024	79.80
786 - Richard's Small Engine, INC	17 - filters for unit 871	03/15/2024	180.92
582 - Town & Country Chrysler Dodge Jeep, INC	17-Bracket stabilier for unit 1200	03/15/2024	33.24
7555 - VoMac Truck Sales & Service INC	17-O-Ring for unit 957	03/15/2024	15.65
7555 - VoMac Truck Sales & Service INC	17-Valve and air dryer for unit 957	03/15/2024	1,075.05
7555 - VoMac Truck Sales & Service INC	17-Hose for unit 958	03/15/2024	36.08
7555 - VoMac Truck Sales & Service INC	17-Tandem pump for unit 957	03/15/2024	1,500.31
2096 - West Side Tractor Sales CO.	17-Roller for unit 656	03/15/2024	350.16
8183 - XL Parts LLC (XL Parts/Dealer Service Warehouse)	17-TPMS Sensor for unit 402	03/15/2024	60.46
8183 - XL Parts LLC (XL Parts/Dealer Service Warehouse)	17-3 connectors for stock	03/15/2024	86.76
8183 - XL Parts LLC (XL Parts/Dealer Service Warehouse)	17-(2) radiator hoses- unit 497	03/15/2024	369.48
Account 52320 - Motor Vehicle Repair Totals		Invoice 45	\$16,157.47
		Transactions	
Account 52420 - Other Supplies			
8181 - Lawson Products, INC	17 - parts/shop supplies-cable ties, lug nuts, socket heads	03/15/2024	1,019.17
6216 - Terminal Supply, INC	17-shop supplies-circuit breaker, drill bits	03/15/2024	177.16



Board of Public Works Claim Register

Invoice Date Range 03/02/24 - 03/15/24

		Account 52420 - Other Supplies Totals	Invoice 2 Transactions	\$1,196.33
Account 53620 - Motor Repairs				
6476 - Samuel D Wray (Wray Automotive)	17 - alignment for unit 251		03/15/2024	100.00
6476 - Samuel D Wray (Wray Automotive)	17 - alignment for unit 1200		03/15/2024	100.00
6476 - Samuel D Wray (Wray Automotive)	17 - alignment unit 863		03/15/2024	100.00
		Account 53620 - Motor Repairs Totals	Invoice 3 Transactions	\$300.00
Account 53920 - Laundry and Other Sanitation Services				
19171 - Aramark Uniform & Career Apparel Group, INC	17-uniform rental (minus payroll ded)- 2/14/24		03/15/2024	82.75
19171 - Aramark Uniform & Career Apparel Group, INC	17 - 4 lab coats - 2/1/2024		03/15/2024	86.95
19171 - Aramark Uniform & Career Apparel Group, INC	17 - City portion Of uniform rentals - 2/21/24		03/15/2024	20.17
19171 - Aramark Uniform & Career Apparel Group, INC	17 - Mat & towel rentals - 2/14/2024		03/15/2024	93.35
19171 - Aramark Uniform & Career Apparel Group, INC	17 - Mat & towel rentals - 2/21/24		03/15/2024	93.35
		Account 53920 - Laundry and Other Sanitation Services Totals	Invoice 5 Transactions	\$376.57
Account 53990 - Other Services and Charges				
3560 - First Financial Bank / Credit Cards	17 - title fees for City vehicle-2/15/2024		03/15/2024	45.00
3560 - First Financial Bank / Credit Cards	17 - title fees for City vehicle-2/9/2024		03/15/2024	90.00
3560 - First Financial Bank / Credit Cards	17 - title fees for City vehicle-Unit #671		03/15/2024	45.00
3560 - First Financial Bank / Credit Cards	17 -title fees for City vehicle for unit 533, 534, 553, 554. 555		03/15/2024	90.00
3892 - Midwest Color Printing, INC	17-250 business cards-Axson, Snider, Lazell		03/15/2024	194.49
		Account 53990 - Other Services and Charges Totals	Invoice 5 Transactions	\$464.49
		Program 170000 - Main Totals	Invoice 70 Transactions	\$124,926.87
		Department 17 - Fleet Maintenance Totals	Invoice 70 Transactions	\$124,926.87
		Fund 802 - Fleet Maintenance(\$9500) Totals	Invoice 70 Transactions	\$124,926.87



Board of Public Works Claim Register

Invoice Date Range 03/02/24 - 03/15/24

Fund 804 - Insurance Voluntary Trust

Department 12 - Human Resources

Program 120000 - Main

Account 53990.1271 - Other Services and Charges Section 125 - URM- City

17785 - The Howard E. Nyhart Company, INC	12-City/Util URM	03/04/2024	274.54
17785 - The Howard E. Nyhart Company, INC	12-City/Util URM	03/04/2024	132.68
17785 - The Howard E. Nyhart Company, INC	12-City URM	03/04/2024	166.30

Account 53990.1271 - Other Services and Charges Section 125 - URM- City Totals	Invoice 3	\$573.52
	Transactions	

Account 53990.1273 - Other Services and Charges Term Life

18539 - Life Insurance Company Of North America	12-March 2024, Bill Ref # 103094_03/05/2024	03/15/2024	20,416.96
---	---	------------	-----------

Account 53990.1273 - Other Services and Charges Term Life Totals	Invoice 1	\$20,416.96
	Transactions	

Account 53990.1277 - Other Services and Charges Disability STD

18539 - Life Insurance Company Of North America	12-March 2024, Bill Ref # 103094_03/05/2024	03/15/2024	10,362.95
---	---	------------	-----------

Account 53990.1277 - Other Services and Charges Disability STD Totals	Invoice 1	\$10,362.95
	Transactions	

Account 53990.1281 - Other Services and Charges Section 125 - URM- Util

17785 - The Howard E. Nyhart Company, INC	12-City/Util URM	03/04/2024	117.65
17785 - The Howard E. Nyhart Company, INC	12-City/Util URM	03/04/2024	50.00
17785 - The Howard E. Nyhart Company, INC	12-Util URM	03/05/2024	60.00

Account 53990.1281 - Other Services and Charges Section 125 - URM- Util Totals	Invoice 3	\$227.65
	Transactions	

Program 120000 - Main Totals	Invoice 8	\$31,581.08
	Transactions	

Department 12 - Human Resources Totals	Invoice 8	\$31,581.08
	Transactions	

Fund 804 - Insurance Voluntary Trust Totals	Invoice 8	\$31,581.08
	Transactions	

Fund 978 - City 2016 GO Bond Proceeds



Board of Public Works Claim Register

Invoice Date Range 03/02/24 - 03/15/24

Department **06 - Controller's Office**

Program **06016C - 2016 C Jackson Trail**

Account **54310 - Improvements Other Than Building**

399 - American Structurepoint, INC	07-Jackson Creek Trail PH II (CE), Amendment #1- Jan 2024	BC 2023-029	03/15/2024	779.22
409 - Black Lumber Co. INC	07-JCT PHII Drive and Culvert Repair-L angle ZMax		03/15/2024	3.69
409 - Black Lumber Co. INC	07-JCT PHII Drive and Culvert Repair-lumber		03/15/2024	10.34
409 - Black Lumber Co. INC	07-JCT PHII Drive and Culvert Repair-rebar		03/15/2024	34.95
409 - Black Lumber Co. INC	07-JCT PHII Drive and Culvert Repair-lumber, hardware		03/15/2024	52.83
409 - Black Lumber Co. INC	07-JCT PHII Drive and Culvert Repair-lumber, u-bolt		03/15/2024	91.55
409 - Black Lumber Co. INC	07-JCT PHII Drive and Culvert Repair-lumber, hardware		03/15/2024	401.16
409 - Black Lumber Co. INC	07-JCT PHII Drive and Culvert Repair-lumber, screws		03/15/2024	873.73
409 - Black Lumber Co. INC	07-CREDIT-returned U Bolt-Inv 562169		03/15/2024	(12.98)
3515 - Dentons Bingham Greenebaum LLP	07-Jackson Creek Trail-Duke Energy Relocation-July 2023		03/15/2024	2,273.50
3515 - Dentons Bingham Greenebaum LLP	07-Jackson Creek Trail-Duke Energy Relocation-Aug 2023		03/15/2024	1,777.50
3515 - Dentons Bingham Greenebaum LLP	07-Jackson Creek Trail-Duke Energy Relocation-Sept 2023		03/15/2024	2,609.50
334 - Irving Materials, INC	07-JCT PHII Drive and Culvert Repair-flowable fill		03/15/2024	1,212.50
334 - Irving Materials, INC	07-JCT PHII Drive and Culvert Repair-bin blocks		03/15/2024	2,040.00
334 - Irving Materials, INC	07-JCT PHII Drive and Culvert Repair-A-C Stone SD		03/15/2024	2,888.50
334 - Irving Materials, INC	07-JCT PHII Drive and Culvert Repair-A-C Stone SD		03/15/2024	4,200.50
334 - Irving Materials, INC	07-JCT PHII Drive and Culvert Repair-A-C Stone CC		03/15/2024	616.00
334 - Irving Materials, INC	07-JCT PHII Drive and Culvert Repair-A-C Stone SD, washout bags		03/15/2024	684.00
334 - Irving Materials, INC	07-JCT PHII Drive and Culvert Repair-bin block		03/15/2024	320.00
8658 - Kleindorfer's Hardware LLC	07-JCT PHII Drive and Culvert Repair-hydraulic cement		03/15/2024	14.69



Board of Public Works Claim Register

Invoice Date Range 03/02/24 - 03/15/24

7516 - Quality Supply & Tool Co INC	07-JCT PHII Drive and Culvert Repair-level, wire mesh, etc	03/15/2024	456.07
365 - Rogers Group, INC	07-JCT PHII Drive and Culvert Repair-#11 & #53 stone	03/15/2024	1,312.07
365 - Rogers Group, INC	07-JCT PHII Drive and Culvert Repair-#7 stone	03/15/2024	263.12
365 - Rogers Group, INC	07-JCT PHII Drive and Culvert Repair-rip rap, #7 stone	03/15/2024	1,835.60
365 - Rogers Group, INC	07-JCT PHII Drive and Culvert Repair-#11 & #53 stone	03/15/2024	337.66
365 - Rogers Group, INC	07-JCT PHII Drive and Culvert Repair-rip rap	03/15/2024	674.11
8205 - SMYRNA Ready Mix Concrete, LLC (SRM Concrete)	07-JCT PHII Drive and Culvert Repair-concrete	03/15/2024	2,539.50
Account 54310 - Improvements Other Than Building Totals		Invoice 27	<u>\$28,289.31</u>
Program 06016C - 2016 C Jackson Trail Totals		Transactions	
		Invoice 27	<u>\$28,289.31</u>
Department 06 - Controller's Office Totals		Transactions	
		Invoice 27	<u>\$28,289.31</u>
Fund 978 - City 2016 GO Bond Proceeds Totals		Transactions	
		Invoice 27	<u>\$28,289.31</u>
		Transactions	
Fund 987 - Econ Dev LIT Bonds of 2022			
Department 06 - Controller's Office			
Program 060000 - Main			
Account 54510 - Other Capital Outlays			
595 - Weddle Bros Construction Co., INC	06-Public Safety Improvements, App 7	03/15/2024	79,308.33
Account 54510 - Other Capital Outlays Totals		Invoice 1	<u>\$79,308.33</u>
Program 060000 - Main Totals		Transactions	
		Invoice 1	<u>\$79,308.33</u>
		Transactions	
Program 08FIR1 - Fire Station 1			
Account 54510 - Other Capital Outlays			
6985 - Martin Riley, INC	08-Design fees for Station 1 -period ending 1/31/24	03/15/2024	18,621.80
Account 54510 - Other Capital Outlays Totals		Invoice 1	<u>\$18,621.80</u>
Program 08FIR1 - Fire Station 1 Totals		Transactions	
		Invoice 1	<u>\$18,621.80</u>
		Transactions	



Board of Public Works Claim Register

Invoice Date Range 03/02/24 - 03/15/24

Department 06 - Controller's Office Totals	Invoice 2	<u>\$97,930.13</u>
	Transactions	
Fund 987 - Econ Dev LIT Bonds of 2022 Totals	Invoice 2	<u>\$97,930.13</u>
	Transactions	
Grand Totals	Invoice 384	<u><u>\$854,947.81</u></u>
	Transactions	

REGISTER OF CLAIMS
Board of Public Works Claim Register

Date:	Type of Claim	FUND	Description	Bank Transfer	Amount
03/15/24	Claims				\$854,947.81
					<u><u>\$854,947.81</u></u>

ALLOWANCE OF CLAIMS

We have examined the claims listed on the foregoing register of claims, consisting of claims, and except for the claims not allowed as shown on the register, such claims are hereby allowed in the total amount of \$854,947.81

Dated this 12th day of March year of 2024.

 Kyla Cox Deckard, President

 Elizabeth Karon, Vice President

 James Roach, Secretary

I hereby certify that each of the above listed voucher(s) or bill(s) is (are) true and correct and I have audited same in accordance with IC 5-11-10-1.6.

Fiscal Office _____