

Board of Public Works Meeting

October 11, 2022



The City will offer virtual options, including CATS public access television (live and tape-delayed) and

Public comments and questions will be encouraged via Zoom or bloomington.in.gov rather than in person

**REVISED AGENDA
BOARD OF PUBLIC WORKS
October 11, 2022**

A Regular Meeting of the Board of Public Work will be held Tuesday, October 11, 2022 at 5:30 p.m. in the Council Chambers (Rm #115) of City Hall at the Showers Building, 401 N. Morton Street, Bloomington, Indiana and via Zoom by using the following link:

<https://bloomington.zoom.us/j/89880996480?pwd=ZlEvU0dYSWFScjc2bWMzdHRBVWYwUT09>

Meeting ID: 898 8099 6480 Passcode: 041536

The City offers virtual options, including CATS public access television (live and tape- delayed). Comments and questions will be encouraged via Zoom or bloomington.in.gov rather than in person.

Auxiliary aids for people with disabilities are available upon request with adequate notice. Please call 812-349-3411 or email public.works@bloomington.in.gov.

I. MESSAGES FROM BOARD MEMBERS

II. PETITIONS AND REMONSTANCES

III. TITLE VI ENFORCEMENT

1. Abatement at 304 N. Hopewell Dr.

IV. CONSENT AGENDA

1. Approval of Minutes September 27, 2022
2. Resolution 2022-79; Renew Mobile Vendor; Cup of Joy
3. Outdoor Lighting Service Agreement with Duke Energy for on E. 10th Street between Walnut and Indiana; Phase I
4. Service Agreement with Tabor Bruce Architecture & Design, Inc., for Design & Inspection Services
5. Supplement #1 to 2022 HFI HVAC Service Agreement
6. Supplement #2 to 2022 HFI Plumbing Service Agreement
7. Approval of Payroll

V. NEW BUSINESS

1. Resolution 2022-80 to Uphold Order to Remove or Repair at 1635 N. College Ave.
2. Contract with Toole Design Group, LLC for College Ave. and Walnut St. Corridor Study
3. Change Order #2, #3, and #4 for the Neighborhood Greenways Project
4. Memorandum of Understanding with the City of Bloomington Utilities Department for Construction Cost Sharing on the W Allen Neighborhood Greenway Project
5. Request from AEG for lane and sidewalk closures
6. Request from Strauser Construction for Full Street Closure along E 19th St from N Grant St to N Dunn St (October 12, 2022-August 08, 2023)
7. Request from Strauser Construction for Right-of-Way use on E 9th St (October 10, 2022 to January 6, 2023)
8. Contract with TAPCO for “No Turn on Red” Sign Project

VI. STAFF REPORTS & OTHER BUSINESS

VII. APPROVAL OF CLAIMS

VIII. ADJOURNMENT

Staff Report

To: Board of Public Works

From: Christopher J. Wheeler, Assistant City Attorney

Date: October 6, 2022

Re: Request to Abate property at 304 N. Hopewell St., Bloomington, IN

Attachments:

1. Notice(s) of Violation Issued on 8/24/2022, 9/2/2022, 9/14/2022, 9/27/2022.
2. GIS Property Report Card
3. Order for Abatement (proposed)

Facts:

1. BMC § 6.06.020 makes it unlawful “for any person to throw, place, or scatter any garbage, recyclable materials or yard waste over or upon any premises, street, alley, either public or private, or to suffer or permit any garbage, recyclable materials or yard waste to be placed or deposited on the premises owned, occupied or controlled by such person either with or without the intent to later remove, cover, or burn it.”
2. On 8/24/2022, 9/2/2022, 9/14/2022, 9/27/2022, a HAND Neighborhood Compliance Officer inspected the property located at **304 N. Hopewell St.**, Bloomington, IN (Hereinafter the “Property”) and issued a Notices of Violation for deposit of garbage in violation of BMC § 6.06.020 (Hereinafter the “NOV”).
3. The NOV were issued to Coleen Grubb (Hereinafter the “Owner”) the owner of the Property that is in violation of BMC § 6.06.020 in that there is garbage on the property.
4. The violations have not been corrected and the NOV were not appealed.
5. The NOV were posted in a conspicuous place at the Property in accordance with BMC § 6.06.070(b).
6. The Notice of Request to Abate was served on the Owner of the Property by certified mail in accordance with BMC § 6.06.080(b).
7. The abatement order should be continuous.

Status of the Property and Reason for Abatement:

The Property remains out of compliance. Garbage remains thrown, placed and scattered on the property. The property needs to be abated to eliminate the violation and public nuisance.

Staff Recommendation:

Staff recommends that the property be abated as soon as reasonably possible and that the order be continuous in nature.

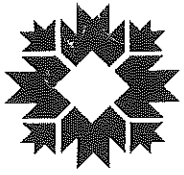

Notice of Violation

Housing & Neighborhood
Development Department (HAND)
P.O. Box 100
401 N. Morton Street
Bloomington, IN 47402
www.bloomington.in.gov/hand/

Date 8.24.22 Time 2p Address/location 304 N. Hopewell St.
47404

Issued by: 219

BMC 6.04.110 Carts, containers and other articles to be picked up shall not be placed upon the street or sidewalk *so as to be visible* from the street more than twenty-four hours prior to the time when such solid waste, recycling or yard waste is to be collected. Carts and containers shall be removed from the street or sidewalk on the same day as the collection is made.

Fine Due: \$15.00 Warning (No fine due at this time) Ticket# _____

NOTE: Immediate compliance required in order to avoid additional violations/fines assessed at \$15.00/day per BMC 6.04.100(c).

BMC 6.06.020 It is unlawful for any person to throw, place, or scatter any garbage, recyclable materials or yard waste over or upon any premises, street, alley, either public or private, or to suffer or permit any garbage, recyclable materials or yard waste to be placed or deposited on the premises owned, occupied or controlled by such person either with or without the intent to remove, cover or burn it.

Fine Due: \$50 \$100 \$150 Warning (No fine due at this time) Ticket# 51860

NOTE: Immediate compliance required in order to avoid additional violations/fines assessed at \$50.00, \$100, or \$150/day per BMC 6.06.070(c).

BMC 6.06.050 It is unlawful for the owner of any lot or tract of ground within the city to allow it to become overgrown with weeds, grass, or noxious plants beyond the height of 8 inches or to such extent that the growth is detrimental to the public health and constitutes a nuisance.

Fine Due: \$50 \$100 \$150 Warning (No fine due at this time) Ticket# _____

NOTE: Immediate compliance required in order to avoid additional violations/fines assessed at \$50.00, \$100, or \$150/day per BMC 6.06.070(c).

Comments: Remove all scattered + accumulated trash + debris from the property per city code.

1. Fine must be paid within 2 weeks from date of issuance of the Notice of Violation (NOV) to avoid this matter being forwarded to the City's Legal Department for further enforcement action. This NOV must be returned with payment. You may pay in person or mail payment to the address listed above. Please make check/money order payable to "The City of Bloomington." All fines listed above may be contested in the Monroe County Circuit Courts.
2. Fines shall not attach to non-possessory residential rental property owner(s) for a period of seven (7) days provided HAND is presented with a true and exact copy of any and all leases in effect during the time period covered by the NOV (per occurrence), at which time said tenant(s) shall be held responsible for fines due. A non-possessory residential rental property owner is the owner of record, but one that is not a resident of said property. Property owner(s) shall otherwise be held responsible for fines if a lease is not presented in the time period indicated.
3. The City may seek action by its Board of Public Works or the Monroe County Circuit Courts in assessing fines, ordering remediation of the property (the City has the authority to bring the property into compliance itself or the City may hire a private third-party contractor to bring the property into compliance) and/or assessing costs associated with clean-up of the property, and pursuing any other remedies available by law, including but not limited to injunctive relief. If the City or their designee, with permission from the City of Bloomington Board of Public Works, enters the property and abates the violation the owner shall be responsible for reimbursing the City for the abatement and all associated cost.
4. This NOV may be appealed to the City's Board of Public Works, provided a written appeal is filed with the Board, via the City's Public Works Department, within seven days of the date of issuance of this NOV.

Owner Name Coleen Grubb
 Address 304 N. Hopewell St.
 City Bigt State IN
 Zip Code 47404

Agent Name _____
 Address _____
 City _____ State _____
 Zip Code _____

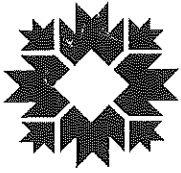

Notice of Violation

**Housing & Neighborhood
Development Department (HAND)**
P.O. Box 100
401 N. Morton Street
Bloomington, IN 47402
www.bloomington.in.gov/hand/

Date 9-2-22 Time 9:30 A Address/location 304 N. Hopewell St.
47404

Issued by: 219

BMC 6.04.110 Carts, containers and other articles to be picked up shall not be placed upon the street or sidewalk *so as to be visible* from the street more than twenty-four hours prior to the time when such solid waste, recycling or yard waste is to be collected. Carts and containers shall be removed from the street or sidewalk on the same day as the collection is made.

Fine Due: \$15.00 Warning (No fine due at this time) Ticket# 51971

NOTE: Immediate compliance required in order to avoid additional violations/fines assessed at \$15.00/day per BMC 6.04.100(c).

BMC 6.06.020 It is unlawful for any person to throw, place, or scatter any garbage, recyclable materials or yard waste over or upon any premises, street, alley, either public or private, or to suffer or permit any garbage, recyclable materials or yard waste to be placed or deposited on the premises owned, occupied or controlled by such person either with or without the intent to remove, cover or burn it.

Fine Due: \$50 \$100 \$150 Warning (No fine due at this time) Ticket# 51972

NOTE: Immediate compliance required in order to avoid additional violations/fines assessed at \$50.00, \$100, or \$150/day per BMC 6.06.070(c).

BMC 6.06.050 It is unlawful for the owner of any lot or tract of ground within the city to allow it to become overgrown with weeds, grass, or noxious plants beyond the height of 8 inches or to such extent that the growth is detrimental to the public health and constitutes a nuisance.

Fine Due: \$50 \$100 \$150 Warning (No fine due at this time) Ticket# _____

NOTE: Immediate compliance required in order to avoid additional violations/fines assessed at \$50.00, \$100, or \$150/day per BMC 6.06.070(c).

Comments: Remove all scattered & accumulated trash & debris from the property per city code. Remove cans from the curb per city code.

1. Fine must be paid within 2 weeks from date of issuance of the Notice of Violation (NOV) to avoid this matter being forwarded to the City's Legal Department for further enforcement action. This NOV must be returned with payment. You may pay in person or mail payment to the address listed above. Please make check/money order payable to "The City of Bloomington." All fines listed above may be contested in the Monroe County Circuit Courts.
2. Fines shall not attach to non-possessory residential rental property owner(s) for a period of seven (7) days provided HAND is presented with a true and exact copy of any and all leases in effect during the time period covered by the NOV (per occurrence), at which time said tenant(s) shall be held responsible for fines due. A non-possessory residential rental property owner is the owner of record, but one that is not a resident of said property. Property owner(s) shall otherwise be held responsible for fines if a lease is not presented in the time period indicated.
3. The City may seek action by its Board of Public Works or the Monroe County Circuit Courts in assessing fines, ordering remediation of the property (the City has the authority to bring the property into compliance itself or the City may hire a private third-party contractor to bring the property into compliance) and/or assessing costs associated with clean-up of the property, and pursuing any other remedies available by law, including but not limited to injunctive relief. If the City or their designee, with permission from the City of Bloomington Board of Public Works, enters the property and abates the violation the owner shall be responsible for reimbursing the City for the abatement and all associated cost.
4. This NOV may be appealed to the City's Board of Public Works, provided a written appeal is filed with the Board, via the City's Public Works Department, within seven days of the date of issuance of this NOV.

Owner Name Colcen Grubb
Address 304 N. Hopewell St.
City Bigt State IN
Zip Code 47404

Agent Name _____
Address _____
City _____ State _____
Zip Code _____

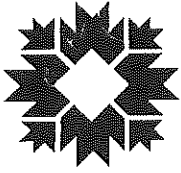

Notice of Violation

Housing & Neighborhood
Development Department (HAND)
P.O. Box 100
401 N. Morton Street
Bloomington, IN 47402
www.bloomington.in.gov/hand/

Date 9-14-22 Time 3⁴⁰ p Address/location 304 N. Hopewell
47404

Issued by: 219

BMC 6.04.110 Carts, containers and other articles to be picked up shall not be placed upon the street or sidewalk *so as to be visible* from the street more than twenty-four hours prior to the time when such solid waste, recycling or yard waste is to be collected. Carts and containers shall be removed from the street or sidewalk on the same day as the collection is made.

Fine Due: \$15.00 Warning (No fine due at this time) Ticket# 52211

NOTE: Immediate compliance required in order to avoid additional violations/fines assessed at \$15.00/day per BMC 6.04.100(c).

BMC 6.06.020 It is unlawful for any person to throw, place, or scatter any garbage, recyclable materials or yard waste over or upon any premises, street, alley, either public or private, or to suffer or permit any garbage, recyclable materials or yard waste to be placed or deposited on the premises owned, occupied or controlled by such person either with or without the intent to remove, cover or burn it.

Fine Due: \$50 \$100 \$150 Warning (No fine due at this time) Ticket# 52212

NOTE: Immediate compliance required in order to avoid additional violations/fines assessed at \$50.00, \$100, or \$150/day per BMC 6.06.070(c).

BMC 6.06.050 It is unlawful for the owner of any lot or tract of ground within the city to allow it to become overgrown with weeds, grass, or noxious plants beyond the height of 8 inches or to such extent that the growth is detrimental to the public health and constitutes a nuisance.

Fine Due: \$50 \$100 \$150 Warning (No fine due at this time) Ticket# _____

NOTE: Immediate compliance required in order to avoid additional violations/fines assessed at \$50.00, \$100, or \$150/day per BMC 6.06.070(c).

Comments: Remove all scattered and accumulated garbage, refuse, rubbish, putrescibles & recyclable materials from the property. Failure to comply will result in daily tickets and going to the Board of Public Works for Abatement.

1. Fine must be paid within 2 weeks from date of issuance of the Notice of Violation (NOV) to avoid this matter being forwarded to the City's Legal Department for further enforcement action. This NOV must be returned with payment. You may pay in person or mail payment to the address listed above. Please make check/money order payable to "The City of Bloomington." All fines listed above may be contested in the Monroe County Circuit Courts.
2. Fines shall not attach to non-possessory residential rental property owner(s) for a period of seven (7) days provided HAND is presented with a true and exact copy of any and all leases in effect during the time period covered by the NOV (per occurrence), at which time said tenant(s) shall be held responsible for fines due. A non-possessory residential rental property owner is the owner of record, but one that is not a resident of said property. Property owner(s) shall otherwise be held responsible for fines if a lease is not presented in the time period indicated.
3. The City may seek action by its Board of Public Works or the Monroe County Circuit Courts in assessing fines, ordering remediation of the property (the City has the authority to bring the property into compliance itself or the City may hire a private third-party contractor to bring the property into compliance) and/or assessing costs associated with clean-up of the property, and pursuing any other remedies available by law, including but not limited to injunctive relief. If the City or their designee, with permission from the City of Bloomington Board of Public Works, enters the property and abates the violation the owner shall be responsible for reimbursing the City for the abatement and all associated cost.
4. This NOV may be appealed to the City's Board of Public Works, provided a written appeal is filed with the Board, via the City's Public Works Department, within seven days of the date of issuance of this NOV.

Owner Name Boleen Grubb
 Address 304 N. Hopewell St.
 City Bloomington State IN
 Zip Code 47404

Agent Name _____
 Address _____
 City _____ State _____
 Zip Code _____

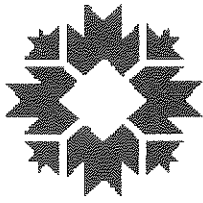

Notice of Violation

Housing & Neighborhood Development Department (HAND)
P.O. Box 100
401 N. Morton Street
Bloomington, IN 47402
www.bloomington.in.gov/hand/

Date 9-27-22 Time 1:15 p Address/location 304 N. Hopewell Dr.

Issued by: 219

BMC 6.04.110 Carts, containers and other articles to be picked up shall not be placed upon the street or sidewalk *so as to be visible* from the street more than twenty-four hours prior to the time when such solid waste, recycling or yard waste is to be collected. Carts and containers shall be removed from the street or sidewalk on the same day as the collection is made.

Fine Due: \$15.00 Warning (No fine due at this time) Ticket# _____

NOTE: Immediate compliance required in order to avoid additional violations/fines assessed at \$15.00/day per BMC 6.04.100(c).

BMC 6.06.020 It is unlawful for any person to throw, place, or scatter any garbage, recyclable materials or yard waste over or upon any premises, street, alley, either public or private, or to suffer or permit any garbage, recyclable materials or yard waste to be placed or deposited on the premises owned, occupied or controlled by such person either with or without the intent to remove, cover or burn it.

Fine Due: \$50 \$100 \$150 Warning (No fine due at this time) Ticket# T62022-09-0030
NOTE: Immediate compliance required in order to avoid additional violations/fines assessed at \$50.00, \$100, or \$150/day per BMC 6.06.070(c). 31

BMC 6.06.050 It is unlawful for the owner of any lot or tract of ground within the city to allow it to become overgrown with weeds, grass, or noxious plants beyond the height of 8 inches or to such extent that the growth is detrimental to the public health and constitutes a nuisance.

Fine Due: \$50 \$100 \$150 Warning (No fine due at this time) Ticket# _____

NOTE: Immediate compliance required in order to avoid additional violations/fines assessed at \$50.00, \$100, or \$150/day per BMC 6.06.070(c).

Comments: Remove all trash, debris + rubbish from the property. This property will be going to the Board of Public Works for permission to Abate if not brought into compliance by 10-11-2022.

1. Fine must be paid within 2 weeks from date of issuance of the Notice of Violation (NOV) to avoid this matter being forwarded to the City's Legal Department for further enforcement action. This NOV must be returned with payment. You may pay in person or mail payment to the address listed above. Please make check/money order payable to "The City of Bloomington." All fines listed above may be contested in the Monroe County Circuit Courts.
2. Fines shall not attach to non-possessory residential rental property owner(s) for a period of seven (7) days provided HAND is presented with a true and exact copy of any and all leases in effect during the time period covered by the NOV (per occurrence), at which time said tenant(s) shall be held responsible for fines due. A non-possessory residential rental property owner is the owner of record, but one that is not a resident of said property. Property owner(s) shall otherwise be held responsible for fines if a lease is not presented in the time period indicated.
3. The City may seek action by its Board of Public Works or the Monroe County Circuit Courts in assessing fines, ordering remediation of the property (the City has the authority to bring the property into compliance itself or the City may hire a private third-party contractor to bring the property into compliance) and/or assessing costs associated with clean-up of the property, and pursuing any other remedies available by law, including but not limited to injunctive relief. If the City or their designee, with permission from the City of Bloomington Board of Public Works, enters the property and abates the violation the owner shall be responsible for reimbursing the City for the abatement and all associated cost.
4. This NOV may be appealed to the City's Board of Public Works, provided a written appeal is filed with the Board, via the City's Public Works Department, within seven days of the date of issuance of this NOV.

Owner Name Cokeen Grubb
 Address 304 N. Hopewell Dr.
 City Bloomington State IN
 Zip Code 47404

Agent Name _____
 Address _____
 City _____ State _____
 Zip Code _____

BPW: 10-11-22

Mail Copies To: Resident: _____ Owner: _____ Agent: _____





OBJECTS IN MIRROR ARE CLOSER THAN THEY APPEAR



OBJECTS IN MIRROR ARE CLOSER THAN THEY APPEAR



Tara
Resort



OBJECTS IN MIRROR ARE CLOSER THAN THEY APPEAR



0917017310



Terry
Resort



Terry
Resort

OBJECTS IN MIRROR ARE CLOSER
THAN THEY APPEAR





Terry
Resort









Monroe County, IN

304 N Hopewell ST, Bloomington, IN 47404-2853
53-05-32-302-001.000-005

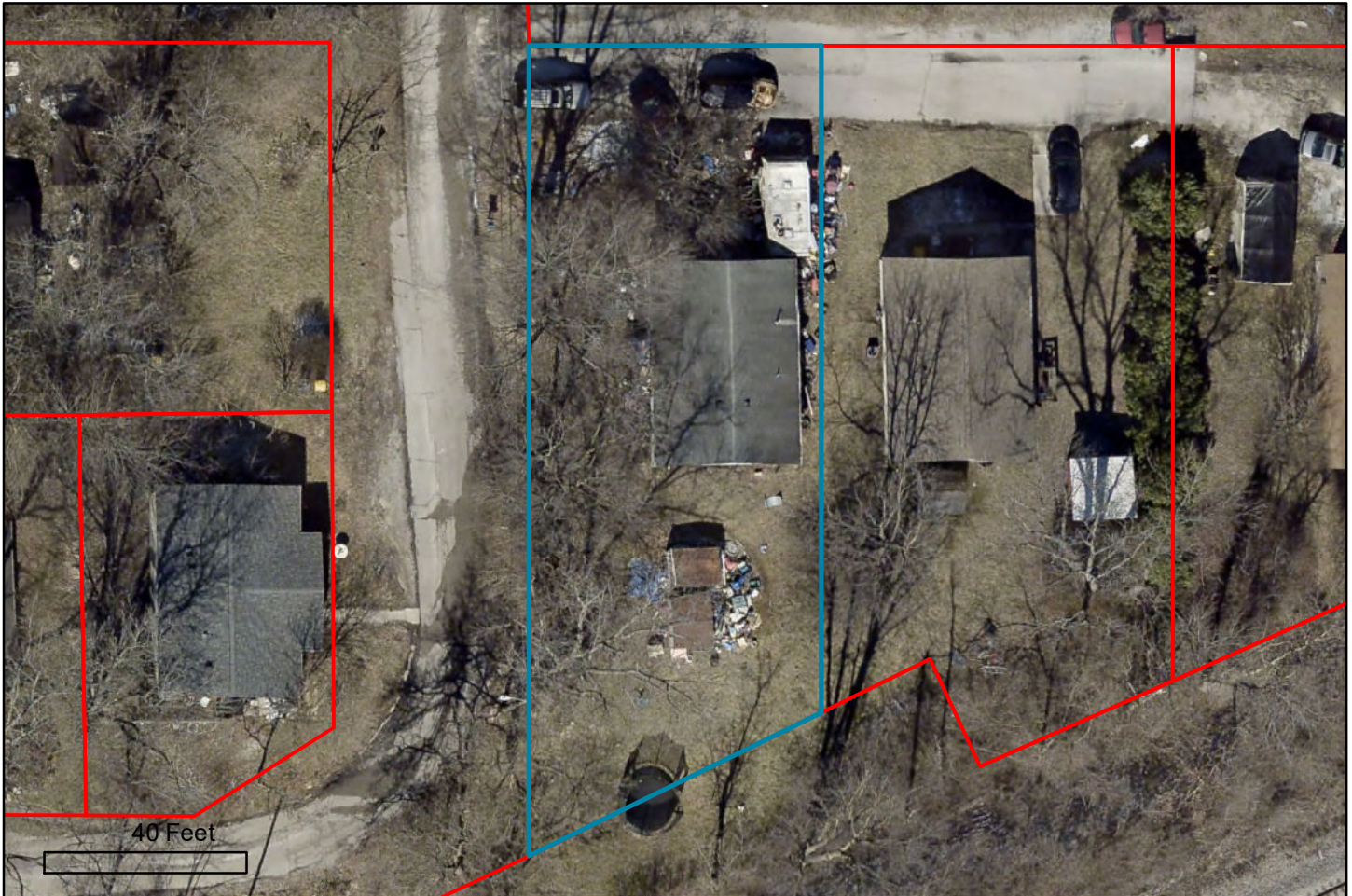

Parcel Information

Parcel Number: 53-05-32-302-001.000-005
Alt Parcel Number: 013-04310-00
Property Address: 304 N Hopewell ST
Bloomington, IN 47404-2853
Neighborhood: 1312B Trending 2008 - A
Property Class: 1 Family Dwell - Platted Lot
Owner Name: Grubb, Coleen
Owner Address: 304 N Hopewell St
Bloomington, IN 47404
Legal Description: 013-04310-00 HABITAT LOT 60A .185A

Taxing District

Township: BLOOMINGTON TOWNSHIP
Corporation: MONROE COUNTY COMMUNITY

Land Description

<u>Land Type</u>	<u>Acreage</u>	<u>Dimensions</u>
9	0.194	

City of Bloomington's Board of Public Works CONTINUOUS Order Of Abatement for NOV

This matter is before the Board of Public Works for Abatement of Notices of Violation issued 8/24/2022, 9/2/2022, 9/14/2022, 9/27/2022, (Hereinafter the "NOV"). The Board of Public Works received information regarding the NOV at its regular meeting on Tuesday, October 11, 2022.

The Board of Public Works now finds as follows:

1. Coleen Grubb (Hereinafter the "Owner") owns the real estate located at **304 N. Hopewell St.**, Bloomington, IN 47404, under parcel number 53-05-32-302-001.000-005 and whose legal description is 013-04310-00 HABITAT LOT 60A .185A (Hereinafter the "Property").
2. On 8/24/2022, 9/2/2022, 9/14/2022, 9/27/2022, a City of Bloomington Neighborhood Compliance Officer issued NOV after personally observing garbage, recyclable materials and yard waste deposited on the Property in violation of BMC § 6.06.020.
3. The NOV were properly issued to the Owner in accordance with BMC 6.06.070(b).
4. The NOV were not appealed.
5. The violation cited in the NOV were not remedied.
6. Notice of the City's request to abate the Property was properly issued and the Owner properly notified in accordance with BMC 6.06.080(b).

After reviewing all of the evidence and testimony presented, the Board of Public Works hereby Orders as follows:

1. The City, via either its employees or a third-party private contractor hired by the City, is authorized to enter into and onto the Property in order to bring said Property into compliance with Chapter 6.06 of the City of Bloomington Municipal Code. Specifically, the City, via either its employees or a third-party contractor hired by the City, is authorized to enter into and onto the Property to remove any and all garbage, recyclable materials and yard waste as those terms are defined in Chapter 6.06 of the City of Bloomington Municipal Code.
2. The City shall bill the Owner for all associated costs of abatement. The Owner shall remit payment in full no later than ten days from receipt of the bill.
3. If the Owner fails to comply with paragraph 2 above, a certified copy of the statement of costs incurred by the City shall be filed in the office of the Monroe County Auditor. The Monroe County Auditor shall thereupon place the amount due on the tax duplicate for the Property.
4. **CONTINUOUS ABATEMENT:** In accordance with Section 6.06.080(e) of the City of Bloomington Municipal Code, this Order of Abatement is a **CONTINUOUS ORDER OF ABATEMENT**. The City is hereby authorized to abate any further ordinance violations of Chapter 6.06 of the City of Bloomington Municipal Code at

this Property concerning deposit of garbage without notice or a hearing in front of this Board while this Order remains in effect.

5. **THIS ABATEMENT ORDER SHALL CONTINUE FOR TWELVE MONTHS AND EXPIRES ON THE 11th DAY OF OCTOBER, 2023.**
6. Public Works shall notify the Owner of this Order and HAND shall post this Order on the Property at the time of abatement.
7. All appeals from the Board's decision on an abatement request shall be made to courts of competent jurisdiction within ten days.

So Ordered this 11TH Day of October, 2022.

Kyla Cox Deckard, President
Board of Public Works
City of Bloomington

The Board of Public Works meeting was held Tuesday, September 27, 2022 at 5:30 pm in the Council Chambers of City Hall at 401 N. Morton St., Bloomington, Indiana and virtually through Zoom with Cox Deckard presiding.

**REGULAR MEETING OF
THE BOARD OF PUBLIC
WORKS**

Present: Kyla Cox Deckard
Elizabeth Karon
Jennifer Lloyd

ROLL CALL

City Staff: Adam Wason – Public Works
April Rosenberger -- Public Works
Chris Wheeler – City Legal
Mike Rouker – City Legal
Rob Council – Housing & Neighborhood Development
Emily Herr -- Engineering
Sara Gomez -- Engineering
Patrick Dierkes -- Engineering
Paul Kehrberg – Engineering
Jason Kerr -- Engineering

None

**MESSAGES FROM BOARD
MEMBERS**

Chris Wheeler, City Legal, presented Appeal Notices of Violation #s 52045 and 52046 at 530 S. Washington. Rob Council, Housing and Neighborhood Development, provided a summary of his interactions with the property owner and his offer to help with cleaning up the property. See meeting packet for details.

**PETITIONS&
REMONSTRANCES**
**Appeal Notices of Violation #s
52045 and 52046 at 530 S.
Washington**

Board Comments: Lloyd asked about the date the photos were taken. Council provided that he had begun taking pictures in August, with the last taken the day before the meeting. Karon asked what precipitated the initial meeting between Council and the property owner in August Council answered that he was following up on a complaint from a neighbor. Cox Deckard asked if there had been any of the noxious plants removed. Council said there had been minimal removal. Lloyd asked what the extent of the progress was on the property. Council answered there has been miniscule progress on the rubbish, and very little on the noxious plants. Cox Deckard asked about a meeting that the property owner mentioned that never came to fruition. Council stated that a meeting was never formally set up.

Joseph Davis, Appellant, stated his issues with statements made by Council. He stated he spoke with Council and other members of staff regarding his wish to have specific direction on what needed to be done on his property and those wishes were never addressed. Davis stated he expressly asked for feedback on the work he had done thus far on his property. He also stated that the items he has on his property are not garbage, they are building materials and other items that will be stored in his basement.

Board Comments: Cox Deckard asked if the item that was near the garbage bin was put out for collection or just sitting in the tree plot. Davis explained that he had been working on the fire damage to his front porch, and the items are building materials related to that work. Karon asked about a picture that shows a trailer with growth all around it, indicating it had been there for a while. Davis stated he had not been presented any of the images provided by HAND and that it would have been useful to see them so he knew what needed to be cleaned up. Karon circled back to a specific picture that has canned goods stored in a cooler, and other items laying on a trailer that has overgrown weeds. Davis stated this is his composting area. Cox Deckard asked if there are items in the tree plots. Wason confirmed. Wason stated that the property is not in compliance with City code. Cox Deckard asked if the time frame to issue a fine, after a warning is given, is typically two weeks. Council confirmed that it is usually one to two weeks, depending on the severity of the issues. Lloyd asked if

there will be additional fines in a few weeks if there isn't any progress made. Council stated he is currently working with other staff to address additional issues. Lloyd asked if a list could be provided showing benchmarks of progress. Council stated he would have to consult the Director, but typically they don't provide such a list. Wason stated that a list could be provided on all the materials that need to be removed.

Karon made a motion to uphold the notices of violation and deny the Appeal of Notices of Violation #s 52045 and 52046 at 530 S. Washington. Lloyd seconded. All in favor, motion is passed.

1. Approval of Minutes; August 13, 2022
2. Adopt-A-Roundabout Partnership with 4 Good Reasons Roofing
3. Resolutuion 2022-75; New Mobile Vendor; Arepa's Burgers
4. Resolution 2022-76; IU Homecoming 5K Run/Walk
5. Resolution 2022-77; Breast Cancer Awareness Walk
6. Resolution 2022-78; Parks & Recreation Holiday Market
7. Agreement to Transfer Monthly Costs of Street Lights in B-Line (Trail View) Subdivision
8. Outdoor Lighting Service Agreement with Duke Energy for E. Discovery Parkway
9. Noise Permit for Community Worship Night
10. Approval of Payroll

CONSENT AGENDA

Karon made a motion to approve the Consent Agenda. Lloyd seconded. All in favor, motion is passed.

Emily Herr, Engineering, presented Request from Renascent Inc. for Lane Closures and Night-time Work on W. 2nd Street (October 3-4, 2022).

Board Comments: Karon asked about the dates being different on the application and staff report. Herr answered that the intention is that the work will be done in 2 nights, but are requesting 4 nights on the application in case of weather delays. Cox Deckard asked about the anticipated noise during the work. Herr confirmed that there wouldn't be heavy machinery noise during quiet hours.

NEW BUSINESS

Request from Renascent Inc. for Lane Closures and Night-time Work on W. 2nd Street (October 3-4, 2022)

Karon made a motion to approve the Request from Renascent Inc. for Lane Closures and Night-time Work on W. 2nd Street (October 3-4, 2022). Lloyd seconded. All in favor, motion is passed.

Sara Gomez, Engineering, presented Change Order #1 for the Dunn St. Sidewalk Improvement Project. See meeting packet for details.

Change Order #1 for the Dunn St. Sidewalk Improvement Project

Board Comments: None

Karon made a motion to approve Change Order #1 for the Dunn St Sidewalk Improvement Project. Lloyd seconded. All in favor, motion is passed.

Patrick Dierkes, Engineering, presented Approve LPA-Consulting Contract with WSP USA Inc. for Preliminary Engineering Services for the West 2nd Street Modernization and Safety Improvements Project. See meeting packet for details.

Approve LPA-Consulting Contract with WSP USA Inc. for Preliminary Engineering Services for the West 2nd Street Modernization and Safety Improvements Project

Board Comments: None.

Karon made a motion to Approve LPA-Consulting Contract with WSP USA Inc. for Preliminary Engineering Services for the West 2nd Street Modernization and Safety Improvements Project. Lloyd seconded. All in favor, motion is passed.

Paul Kehrberg, Engineering, presented Request from Strauser Construction for Right-of-Way Use along E. 19th St. from N. Lincoln St. to N. Dunn St. (Through August 8, 2023). See meeting packet for details.

Request from Strauser Construction for Right-of-Way Use along E. 19th St. from N. Lincoln St. to N. Dunn St. (Through August 8, 2023)

Public Comments: Greg Alexander stated he doesn't understand a lot about this request. Stated there is work already happening and that the right-of-way is being used as part of the construction area. Alexander stated he had counted 38 pedestrians using the street because the sidewalk is missing.

Board Comments: Wason asked for a project update from Engineering staff. Dierkes provided an update, stating the budget did not allow for the sidewalk to continue the entire stretch. Dierkes confirmed that future projects will build out the remaining part of the sidewalk as part of their development. Cox Deckard had a question about the MOT, stating it looks like it follows a sidewalk along Dunn. She asked if there is sidewalk on the other side. Kehrberg explained the MOT included is for the entire project; that tonight's request is just the construction fencing. Cox Deckard asked if a pedestrian wanted to walk to Grant, what the next sidewalk that could be used is. Kehrberg stated the sidewalk would be on 18th St. Wason suggested exploring better alternatives with the pedestrians in the area. Cox Deckard asked if the construction fencing had been approved at staff level. Ryan Strauser, Strauser Construction, stated that when they had submitted the application for a grading permit, the fencing was included.

Karon made a motion to table the Request from Strauser Construction for Right-of-Way Use along E. 19th St. from N. Lincoln St. to N. Dunn St. (Through August 8, 2023). Lloyd seconded. All in favor, motion is passed.

Jason Kerr, Engineering, presented Request from Reed and Sons Construction for Full Street Closure on N. Bryan St. from E. 5th St. to E. 7th St. (October 3-7, 2022). See meeting packet for details.

Request from Reed and Sons Construction for Full Street Closure on N. Bryan St. from E. 5th St. to E. 7th St. (October 3-7, 2022)

Board Comments: Cox Deckard wanted to make a note that the street name is actually Bryan Ave. not Bryan St.

Karon made a motion to approve Request from Reed and Sons Construction for Full Street Closure on N. Bryan Ave. from E. 5th St. to E. 7th St. (October 3-7, 2022). Lloyd seconded. All in favor, motion is passed.

Paul Kehrberg, Engineering, presented Request from FA Wilhelm for Sidewalk Closure along the South Side of W. Allen St. West of S. Strong Dr. (September 28, 2022-January 22, 2023). See meeting packet for details.

Request from FA Wilhelm for Sidewalk Closure along the South Side of W. Allen St. West of S. Strong Dr. (September 28, 2022-January 22, 2023)

Board Comments: Cox Deckard asked to confirm that Mother Hubbard's Cupboard had received notification of the closure. Kehrberg confirmed that letters were sent out.

Public Comment: Greg Alexander spoke of the sidewalk not connecting to anything. He feels it is irresponsible to ask pedestrians to walk in the street. He asked if the Council could be more informed of when there is a problem with a sidewalk.

Karon made a motion to approve Request from FA Wilhelm for Sidewalk Closure along the South Side of W. Allen St. West of S. Strong Dr. (September 28, 2022-January 22, 2023). Lloyd seconded. All in favor, motion is passed.

Paul Kehrberg, Engineering, presented Request from AEG for Right-of-Way use along E Atwater Ave., E. 1st St., S Fess Ave., and S. Mitchell St. (October 4, 2022-November 4, 2022). See meeting packet for details.

Request from AEG for Right-of-Way use along E, Atwater Ave., E 1st St., S Fess Ave., and S. Mitchell St. (October 4, 2022-November 4, 2022)

Board Comments: Cox Deckard wanted to highlight that there wasn't a request to close the right-of-way, just for work in the right-of-way. Kehrberg stated there would be intermittent lane and sidewalk closures.

Karon made a motion to approve Request from AEG for Right-of-Way use along E. Atwater

Ave., E. 1st St., S. Fess Ave., and S. Mitchell St. October 4, 2022-November 4, 2022).
Lloyd seconded. All in favor, motion is passed.

Adam Wason, Public Works, presented Contract with Express Employment Professionals for Parking Enforcement Specialists (2 Positions). See meeting packet for details.

**Contract with Express
Employment Professionals for
Parking Enforcement
Specialists (2 Positions)**

Board Comments: Lloyd asked if the temporary employees would essentially fall into the role of the full time City employees. Wason answered that he hoped the temporary employees enjoy their work and complete the application on time for the full time positions.

Public Comments: Greg Alexander reminded everyone that citations were promised regarding the scooters.

Karon made a motion to approve Contract with Express Employment Professionals for Parking Enforcement Specialists (2 Positions). Lloyd seconded. All in favor, motion is passed.

Adam Wason, Public Works, presented Contract with MSI Security for School Crossing Guard Positions. See meeting packet for details.

**Contract with MSI Security for
School Crossing Guard
Positions**

Board Comments: None

Karon made a motion to approve Contract with MSI Security for School Crossing Guard Positions. Lloyd seconded. All in favor, motion is passed.

Adam Wason, Public Works, presented Contract with Strauser Construction for Lower Level Renovation at Fire Station #2 on behalf of J.D. Boruff. See meeting packet for details.

**Contract with Strauser
Construction for Lower Level
Renovation at Fire Station #2**

Board Comments: Lloyd asked if the renovation is an expansion or replacement of the existing sleeping quarters. Wason stated he believes it is additional sleeping quarters. Mike Rouker, City Legal, confirmed.

Karon made a motion to approve Contract with Strauser Construction for Lower Level Renovation at Fire Station #2. Lloyd seconded. All in favor, motion is passed.

Adam Wason, Public Works, Change Order #2 for the Lower Cascades Project with E&B Paving. See meeting packet for details.

**Change Order #2 for the
Lower Cascades Project with
E&B Paving**

Board Comments: None

Karon made a motion to approve Change Order #2 for the Lower Cascades Project with E&B Paving. Lloyd seconded. All in favor, motion is passed.

Wason wanted to express a huge thank you to Jackie Moore for her seventeen years of service to the City. He wished her all the best in her retirement. Cox Deckard extended the Board's thanks to Jackie as well.

**STAFF REPORTS AND
OTHER BUSINESS**

Board Comments: Cox Deckard asked if the claim for Marshall Security was for Public Works and if it was billed against the contract we have with them. Wason stated it was a stand-alone fee for help during the 4th Street Arts Festival.

CLAIMS

Karon made a motion to approve claims in the amount of \$647,099.86. Lloyd seconded. All in favor, motion is passed.

Cox Deckard called for adjournment at 6:52 p.m.

Accepted By:

Kyla Cox Deckard, President

09/27/2022

Jennifer Lloyd, Vice President

ADJOURNMENT

Elizabeth Karon, Secretary

Date:

Attest to:

09/27/2022

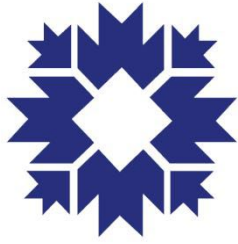

CITY OF BLOOMINGTON

ECONOMIC AND SUSTAINABLE DEVELOPMENT

Project/Event: Mobile Vendor in Right of Way
PW Resolution No: 2022-79
Petitioner/Representative: Elizabeth Tragesser, Owner of Cup of Joy
Staff Representative: Susan Coates
Meeting Date: 10/10/2022

Cup of Joy, by its owner, Elizabeth Tragesser, has applied for a Mobile Vendor License to operate a food truck/trailer. An applicant wanting to operate in the right of way must obtain permission from the Board of Public Works before a license may be issued. The Department of Economic & Sustainable Development has reviewed the application and will confirm that all rules and regulations have been met prior to issuing a license.

The business will be selling food via a mobile kitchen and food truck.

This application is for 1 year.

Staff is supportive of the request.

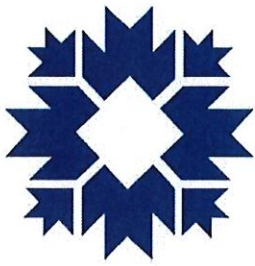

CITY OF BLOOMINGTON

ECONOMIC AND SUSTAINABLE DEVELOPMENT

Business License Cover Sheet

Business Name	Cup of Joy
License Type	Mobile Vendor License
Contact	Elizabeth Tragesser
Phone	812-272-7582
Email	cupofjoyfoodtruck@gmail.com
BPW Resolution No (if applicable)	2022-79
Issue Date of License	10/10/2022
Expiration Date of License	10/10/2023
Scanned?	<input checked="" type="checkbox"/>
Renewal Date for License	10/10/2023
Department Head	Alex Crowley
Record Destruction Date	10/10/2026
ESD Tracking No	N/A
Document Physical Filing Location	2-drawer file cabinet at ESD Admin's desk
Document Digital Filing Location	I:\common\Economic Development\BUSINESS\Business Licensing\Licenses\Mobile Vendor License\Businesses

Date: 9/26/22

Cup of Joy



CITY OF BLOOMINGTON

MOBILE VENDOR LICENSE APPLICATION

City of Bloomington
Department of Economic and Sustainable Development
401 N. Morton St. Suite 150
Bloomington, Indiana 47404
812-349-3418

1. License Length and Fee Application

Length of License:	<input type="checkbox"/> 24 Hours	<input type="checkbox"/> 3 Days	<input type="checkbox"/> 7 Days	<input type="checkbox"/> 30 Days	<input type="checkbox"/> 3 Months	<input type="checkbox"/> 6 Months	<input checked="" type="checkbox"/> 1 Year
License Fee:	\$25	\$30	\$50	\$75	\$150	\$200	\$350

2. Applicant Information

Name:	Elizabeth Traegesser		
Title/Position:	Owner		
Date of Birth:	8-22-1983		
Address:	6794 W. Vernal Pike		
City, State, Zip:	Bloomington, IN 47404		
E-Mail Address:	cupofjoyfoodtruck@gmail.com		
Phone Number:	812-272-7582	Mobile Phone:	

3. Indiana Contact Information (For non-residents only)

If applicant is not a resident of Indiana, they must designate a resident to serve as a contact.

Name:			
Address:			
City, State, Zip:			
E-Mail Address:			
Phone Number:		Mobile Phone:	

Received in ESD
SEP 26 2022

BPW- 10/10/22

4. Company Information					
Name of Employer:	Cup of Joy				
Address of Employer:	6794 W. Vernal Pike				
City, State, Zip:	Bloomington, IN 47404				
Employment Start Date:		End Date (If known):			
Phone Number:	812-272-7582				
Website / Email:					
Company is a:	<input checked="" type="checkbox"/> Limited Liability Corporation (LLC)	<input type="checkbox"/> Corporation	<input type="checkbox"/> Partnership	<input type="checkbox"/> Sole Proprietor	<input type="checkbox"/> Other:

5. Company Officer Information	
Provide the names and addresses of all principal officers, partners, trustees, owners or other persons with controlling interests in the company.	
Name	Address
Brady Traverser - Partner	6794 W. Vernal Pike Bloomington, IN 47404

6. Company Incorporation Information (For Corporations and LLCs Only)	
Date of incorporation or organization:	09/13/2020
State of incorporation or organization:	INDIANA
(If Not Indiana) Date qualified to transact business in state of Indiana:	

7. Description of product or service to be sold and any equipment to be used

Planned hours of operation:	24 hours per day, usually morning (7-11)
Place or places where you will conduct business (If private property, attach written permission from property owner):	Fairgrounds, Switchyard park, Amvets, South Union Church, various
Scaled site plan showing the location of the proposed mobile food vendor unit and the properties' drives, parking access aisles, fire lanes, sidewalks and accessible routes.	Please Attach
Have you had a similar license, either from the City of Bloomington, or a different municipality, revoked?	Yes <input type="checkbox"/> No <input checked="" type="checkbox"/>
(If Yes) Provide details	

8. You are required to secure, attach, and submit the following:

- A copy of the Indiana registration for the vehicle
- Copy of a valid driver's license
- Copy of an Indiana Driver's Record and/or equivalent of whatever State has issued the applicant his/her driver's license
- Proof of an independent safety inspection of all vehicles to be used in the business
- Proof of insurance in accordance with the limits described in Section 4.28.090 of the Bloomington Municipal Code:
 - Personal Injury: \$100,000.00 per occurrence and \$300,000 in the aggregate
 - Property Damage: \$25,000.00 per occurrence and \$50,000.00 in the aggregate
- Release of liability wherein the Applicant agrees to indemnify and hold harmless the City of Bloomington for losses or expenses arising out of the operation of his/her business.
- A copy of the business's registration with the Indiana Secretary of State.
- A copy of the Employer ID number
- A signed copy of the Prohibited Location Agreement
- A signed copy of the Standards of Conduct Agreement
- Fire inspection (if required)
- Picture of truck or trailer
- Copy of all applicable permits required by the Monroe County Health Department, including but not limited to a Food Service Establishment License or a Certified Food Handler

*Not
? rec'd
OK*

For City Of Bloomington Use Only

Date Received: *9/26/22* Received By: *J Coats* Date Approved: Approved By:

John Hamilton
Mayor
CITY OF BLOOMINGTON
401 N. Morton St Suite 130
P.O. Box 100
Bloomington, Indiana 47402

**DEPARTMENT OF ECONOMIC
& SUSTAINABLE DEVELOPMENT**
p. 812.349.3418
f. 812.349.3520

RELEASE, HOLD-HARMLESS AND INDEMNIFICATION AGREEMENT

The undersigned, in consideration for the issuance of a license by the City of Bloomington Controller, agrees to the following:

1. The undersigned, in exchange for the issuance of a license by the City of Bloomington Controller, agrees to release, hold harmless, and forever indemnify the City of Bloomington and any and all City employees, officers, and agents from any claim or claims which may arise out of any incident connected with or in any way related to his/her issuance of a license by the City of Bloomington or his/her operation of a business which was licensed by the City of Bloomington. This includes claims for personal injury, death, property damage, and/or any other type of harm or injury.
2. The undersigned shall, and hereby does, indemnify, defend, and hold harmless the City of Bloomington and any and all City employees, officers, and agents from and against any and all actions, costs, claims, suits, losses, expenses or damages, including but not limited to attorneys' fees and court costs, arising out of the undersigned's operation of a business which has been licensed by the City of Bloomington.
3. The undersigned understands this release binds him/herself, his/her spouse, and all heirs, executors, partners, co-owners and administrators of those individuals.

The undersigned acknowledges that he/she has read this release and understands all of its terms. The undersigned signs this release voluntarily and with full knowledge of its significance.

Elizabeth Traggasser
Name, Printed

E. Traggasser
Signature

9/24/2022
Date Release Signed

John Hamilton
Mayor
CITY OF BLOOMINGTON
401 N. Morton St Suite 130
P.O. Box 100
Bloomington, Indiana 47402

**DEPARTMENT OF ECONOMIC
& SUSTAINABLE DEVELOPMENT**
p. 812.349.3418
f. 812.349.3520

Prohibited Location Agreement

Bloomington Municipal Code Section 4.28.140 prohibits Mobile Vendor Units from operating in certain locations. This Agreement provides for all of the prohibited locations. Two maps are also attached to this Agreement. All signatories to this Agreement are required to review not only this Agreement, but also the attached maps prior to signing this Agreement.

As a licensed Mobile Vendor Unit, I understand and agree that I cannot and will not operate my mobile vendor unit in a manner that would violate any of the below-listed location restrictions:

- € No mobile food vendor unit shall locate in any parking lot, parking space, or parking facility owned, leased or managed by the City of Bloomington unless approval has been given by the City's Board of Public Works.
- € No mobile food vendor unit shall operate within fifty feet of any facade of a ground level establishment that also sells food or beverages, or operate within fifty feet of the perimeter of such an establishment's outdoor seating area, regardless of whether or not the mobile food vendor unit is currently conducting business. The distance restriction only applies from one hour before the opening time to an hour after the closing time posted by a ground level establishment on the facade of its building.
- € No mobile food vendor unit shall locate in an alleyway.
- € Mobile food vendor units shall be located a reasonable distance from all posted bus stops, crosswalks, driveways, alleyways, right-of-way lines of two or more intersecting streets and building entrances or walk-up windows.
- € Mobile food vendor units shall only be located on private property if the private property owner has provided both the business operator and the City written permission for the mobile food vendor unit to locate on said property.
- € No mobile food vendor unit shall locate within a one block radius of a Special Event unless prior approval has been granted by either the operator of the Special Event or the City's Board of Public Works.
- € No mobile food vendor unit shall park on City property in violation of any City parking regulation, restriction, or ordinance. For example, if parking at one, or multiple, parking meters, the operator of the mobile food vendor unit shall feed all relevant parking meters with the required monetary amount.
- € No mobile food vendor unit shall be located in a manner which would significantly impede or prevent the use of any City of Bloomington property, or which would endanger the safety or property of the public.
- € No mobile food vendor unit shall be located within fifteen feet of any fire hydrant.

- € No mobile food vendor shall locate within any zoning district except the following: Commercial General; Commercial Arterial; Commercial Downtown; Industrial General; Business Park; and Institutional.
- € No mobile food vendor operating on private property shall displace required parking or landscaping nor block any drives, parking access aisles, fire lanes, sidewalks, or accessible routes required for the private parking by the City's zoning code.
- € No mobile food vendor unit shall be located more than one foot away from the curb of the street on which it is parked.
- € No mobile food vendor unit shall park near an intersection and in a manner that blocks the line-of-sight of drivers using adjacent roadways.

I, the undersigned, understand that if I locate my mobile vendor unit in any of the above-described prohibited locations or manner that I subject myself to fines and possible revocation of my Mobile Vendor Unit License, as so described in Chapter 4.28 of the Bloomington Municipal Code.

Vendor:

Name: Elizabeth Traggner

Signature: E. Traggner

Date: 9/24/2022

John Hamilton
Mayor
CITY OF BLOOMINGTON
401 N. Morton St Suite 130
P.O. Box 100
Bloomington, Indiana 47402

DEPARTMENT OF ECONOMIC
& SUSTAINABLE DEVELOPMENT
p. 812.349.3418
f. 812.349.3520

Standard of Conduct Agreement

Bloomington Municipal Code Section 4.28.160 provides Standards of Conduct for all Mobile Vendor Units. This Agreement provides a list of said Standards of Conduct. All signatories to this Agreement are required to review this Agreement prior to signing this Agreement.

As a licensed Mobile Vendor Unit, I understand and agree that I cannot and will not conduct business in a manner that would violate any of the Standards of Conduct noted below:

- € Mobile food vendor unit operators shall conduct themselves at all times in an orderly and lawful manner, and shall not make, or cause to be made, any unreasonable noise of such volume as to be in violation of the City of Bloomington Noise Ordinance as stated in Title 14 of the Bloomington Municipal Code
- € A device may not be used which would amplify sounds nor may attention be drawn to the mobile food vendor unit by an aural means or a light-producing device (examples of such devices may include, but are not meant to be limited to the following: bull horns and strobe lights
- € No mobile food vendor unit may be permanently or temporarily affixed to any object, including but not limited to buildings, trees, telephone poles, streetlight poles, traffic signal poles or fire hydrants
- € No mobile food vendor unit may be used to advertise any product which is not authorized to be sold from that unit
- € Each mobile food vendor unit shall be limited to one sandwich board sign that meets the provisions of Section 20.05.086 of the Bloomington Municipal Code regardless of the zoning district in which it locates, provided a sign permit is obtained from the City's Planning and Transportation Department
- € No mobile food vendor unit may make use of any public or private electrical outlet while in operation
- € Each mobile food vendor unit shall protect against littering and shall have both an adequate trash receptacle and a separate receptacle for recyclable materials:
 - o The trash and recyclable receptacles shall be emptied sufficiently often to allow disposal of litter and waste by the public at any time;
 - o The trash and recyclable receptacles on the mobile food vendor unit shall not be emptied into trash or recyclable receptacles owned by the City of Bloomington;
 - o Liquid from the mobile food vendor unit shall not be discharged on or in a City sewer or drain or elsewhere on City property, nor on private property without the express written consent of the owner thereof;

- Before leaving any location each mobile food vendor unit shall first pick up, remove and dispose of all trash, refuse and/or recyclable materials, including products spilled on the ground within twenty feet of the mobile food vendor unit.
- € No mobile food vendor unit shall expose any pedestrian to any undue safety or health hazards nor shall it be maintained so as to create a public nuisance
- € Each mobile food vendor unit shall be maintained free and clear of dirt, and finishes shall not be chipped, faded or unduly marred
- € Foods or beverages which present a substantial likelihood that liquid matter or particles will drop to the street or sidewalk during the process of carrying or consuming the food or beverage shall be sold in proper containers so as to avoid falling to the street or sidewalk
- € Mobile food vendor units which utilize a grill or device that may result in a spark, flame or fire shall adhere to the following additional standards:
 - Be placed approximately 20 feet from a building or structure;
 - Provide a barrier between the grill or device and the general public;
 - The spark, flame or fire shall not exceed 12 inches in height;
 - A fire extinguisher shall be within reaching distance of the mobile food vendor unit operator at all times;
- € Mobile food vendor unit operators shall be required to obey the commands of law enforcement officers or fire officials with respect to activity carried out inside of the City's jurisdictional limits, including, where possible, the removal of the mobile food vendor unit and cessation of such sales
- € No mobile food vendor unit shall ever be left unattended
- € Mobile food vendor units shall not be stored, parked or left overnight on any City property
- € All mobile food vendor units which are food service establishments as defined by Title 10.17 of the Bloomington Municipal Code shall install an approved grease interceptor or grease trap. Foods, oils and greases shall never be discharged into the City's sewer or storm drains
- € All mobile food vendor unit operators are required to collect and pay all applicable and appropriate sales taxes
- € No mobile food vendor shall provide customer seating unless approval has been provided by the City's Board of Public Works and the City's Planning and Transportation Department
- € All mobile food vendors shall comply with the lighting standards found in Chapter 20.05 of the Bloomington Municipal Code
- € All mobile food vendors shall comply with the vision clearance standards found in Chapter 20.05 of the Bloomington Municipal Code
- € No mobile food vendor shall have a drive-thru
- € The decibels of any generator(s) associated with a mobile food vendor unit shall not exceed "70dBA".
 - Such noise measurement shall be made at a height of at least four (4) feet above the ground and at a point approximately twenty-five (25) feet away from where the

noise is being emitted on a sound level meter operated on the "A" weighting network (scale).

- o No person other than the operators shall be within twenty-five (25) feet of the sound level meter during the sample period.
- o Sound measurements shall be conducted at that time of day or night when the relevant noise source is emitting sound.
- o The sound level measurement shall be determined as follows:
 - Calibrate the sound level meter within one (1) hour before use.
 - Set the sound level meter on the "A" weighted network at slow response.
 - Set the omnidirectional microphone in an approximately seventy degree position in a location which complies with subsections (1) and (2) herein. The operator of the sound level meter shall face the noise source and record the meter's instantaneous response.
 - Recalibrate the sound level meter after use.
- o It shall be unlawful for any person to interfere, through the use of sound or otherwise, with the taking of sound level measurement.

I, the undersigned, understand that if I conduct business in violation of any the above described standards of conduct that I subject myself to fines and possible revocation of my Mobile Vendor Unit License, as so described in Chapter 4.28 of the Bloomington Municipal Code.

Vendor:

Name: Elizabeth Tragesser

Signature: E. Tragesser

Date: 9/24/2022



CUSTOMER NAME: BRADY JOHN TRAGESSER
Make: CHE
Year: 1997
Model: GMT-400 K1500
VIN/HIN: 1GCEK19R6VE258329
Plate Number: TK457NVT
LAST RENEWAL DATE: 11/09/21
EXPIRATION DATE: 11/14/22

2022 Registration Fees

AGE:	25
VEHICLE EXCISE TAX:	\$21.00
COUNTY VEHICLE EXCISE/WHEEL TAX:	\$25.00
MUNICIPAL VEHICLE EXCISE/WHEEL TAX:	\$0.00
GROUP FEE:	\$0.00
SPECIAL REG. FEE:	\$0.00
REG. FEE:	\$30.35
TRANSPORTATION INFRASTRUCTURE IMPROVEMENT:	\$15.00
SUPPLEMENTAL FEE:	\$0.00
ADMIN:	\$0.00
Total:	\$91.35

- myBMV Home
- Plates And Registrations
- Vehicle Titles
- Licenses And ID Cards
- Driver Records
- Suspension & Reinstatement
- my Information
- Driver Training

Sign Out

my Driver Records

[View Your Driver Record](#)

my Driver Records

Welcome, ELIZABETH F TRAGESSER!

[Official Driver Record](#)

[Pay Reinstatement Fees Online](#)

[Renew Your License, Permit or ID Card](#)

[Add MotorCycle Endorsement](#)

[View Your Recent Driver Notices](#)

[Track Your Recent Renewals](#)

[Replace Your License, Permit or ID Card](#)

[Schedule Driving Test](#)

[Your Renewal Date](#)

[CDL Self-Certify Driver Type](#)

[Proceed to Checkout](#)

Click to Verify - This site chose VeriSign SSL for secure e-commerce and confidential communications.
[ABOUT SSL CERTIFICATES](#)

**** NOTE: The BMV only retains supporting documentation for a period of ten (10) years ****

License type: DRIVERS

As of 09/26/2022 11:02 am
IINT

License status: VALID

SR22: Not needed

Current points: 0

Endorsements: None

Pending Endorsements: None

Restrictions: None

Pending Restrictions: None

Suspension Information -- (* indicates active suspensions)

-- (** indicates closed/expired active suspensions stayed)

No Suspensions were found.

Pending Suspension Information

No Pending Suspensions were found.

Disqualification Information -- (* indicates active disqualifications)

No Disqualifications were found.

Pending Disqualification Information

No Pending Disqualifications were found.

Out of State Withdrawal Information

No OOS Withdrawals were found.

Convictions -- (* indicates active points)

Disposition Date	Offense Pts	Offense Description	Offense Date	Court / Case Number	Susp IDs	Disq IDs	CMV	Hazmat
11/28/2001	4	SPEEDING 72/55	10/29/2001	GAS CITY CITY / 27H010111F06392			No	No

Mailing Addresses

ID	Effective Date	Street Address	City	State	ZIP Code
4	08/11/2012	7020 E STATE ROAD 45	BLOOMINGTON	IN	47408-9553
3	10/09/2008	2720 N THOMAS RD	BLOOMINGTON	IN	47404-9655

2	11/17/2006	295 W HICKORY DR	ELLETTSVILLE	IN	47429-1109
1	09/22/1999	6794 W VERNAL PIKE	BLOOMINGTON	IN	47404-9100

Legal Addresses

ID	Effective Date	Street Address	City	State	ZIP Code
4	08/11/2012	7020 E STATE ROAD 45	BLOOMINGTON	IN	47408-9553
3	10/09/2008	2720 N THOMAS RD	BLOOMINGTON	IN	47404-9655
2	11/17/2006	295 W HICKORY DR	ELLETTSVILLE	IN	47429-1109
1	09/22/1999	6794 W VERNAL PIKE	BLOOMINGTON	IN	47404-9100

Credential Issuance

Issue Date: 09/01/2018, Renew License, DRIVERS, Endorsements: None, Restrictions: None, Expiration Date: 08/22/2024

Interim Credential Issue Date: 8/11/2012, Expiration Date: 9/10/2012, Reason: RENEWAL DL W/O CARD, IN-STATE, Control #: 3297427

Issue Date: 08/11/2012, Renew License, DRIVERS, Endorsements: None, Restrictions: None, Expiration Date: 08/22/2018

Issue Date: 10/09/2008, Renew License, DRIVERS (4 YR), Endorsements: None, Restrictions: None, Expiration Date: 08/22/2012

Issue Date: 11/17/2006, Amend License, DRIVERS, Endorsements: None, Restrictions: None, Expiration Date: 08/22/2008

Issue Date: 08/24/2004, Renew License, DRIVERS, Endorsements: None, Restrictions: None, Expiration Date: 08/22/2008

Issue Date: 09/22/1999, Renew License, DRIVERS, Endorsements: None, Restrictions: None, Expiration Date: 08/22/2004

Issue Date: 12/28/1998, Renew ID Card, REGULAR ID CARD, Endorsements: None, Restrictions: None, Expiration Date: 12/31/2002

Issue Date: 12/28/1998, Issue Driver's Ed, DRIVER EDUCATION, Endorsements: None, Restrictions: None, Expiration Date: 12/31/1999

Remarks

No Remarks were found.

 * End of Driver Record *



CERTIFICATE OF LIABILITY INSURANCE

DATE (MM/DD/YYYY)

10/20/2021

THIS CERTIFICATE IS ISSUED AS A MATTER OF INFORMATION ONLY AND CONFERS NO RIGHTS UPON THE CERTIFICATE HOLDER. THIS CERTIFICATE DOES NOT AFFIRMATIVELY OR NEGATIVELY AMEND, EXTEND OR ALTER THE COVERAGE AFFORDED BY THE POLICIES BELOW. THIS CERTIFICATE OF INSURANCE DOES NOT CONSTITUTE A CONTRACT BETWEEN THE ISSUING INSURER(S), AUTHORIZED REPRESENTATIVE OR PRODUCER, AND THE CERTIFICATE HOLDER.

IMPORTANT: If the certificate holder is an ADDITIONAL INSURED, the policy(ies) must have ADDITIONAL INSURED provisions or be endorsed. If SUBROGATION IS WAIVED, subject to the terms and conditions of the policy, certain policies may require an endorsement. A statement on this certificate does not confer rights to the certificate holder in lieu of such endorsement(s).

PRODUCER Hiscox Inc. 5 Concourse Parkway Suite 2150 Atlanta GA, 30328	CONTACT NAME: PHONE (A/C, No, Ext): (888) 202-3007 FAX (A/C, No): E-MAIL ADDRESS: contact@hiscox.com	
	INSURER(S) AFFORDING COVERAGE INSURER A: Hiscox Insurance Company Inc	NAIC # 10200
INSURED Cup Of Joy 7020 E State Road 45 Bloomington IN 47408	INSURER B:	
	INSURER C:	
	INSURER D:	
	INSURER E:	
	INSURER F:	

COVERAGES

CERTIFICATE NUMBER:

REVISION NUMBER:

THIS IS TO CERTIFY THAT THE POLICIES OF INSURANCE LISTED BELOW HAVE BEEN ISSUED TO THE INSURED NAMED ABOVE FOR THE POLICY PERIOD INDICATED. NOTWITHSTANDING ANY REQUIREMENT, TERM OR CONDITION OF ANY CONTRACT OR OTHER DOCUMENT WITH RESPECT TO WHICH THIS CERTIFICATE MAY BE ISSUED OR MAY PERTAIN, THE INSURANCE AFFORDED BY THE POLICIES DESCRIBED HEREIN IS SUBJECT TO ALL THE TERMS, EXCLUSIONS AND CONDITIONS OF SUCH POLICIES. LIMITS SHOWN MAY HAVE BEEN REDUCED BY PAID CLAIMS.

INSR LTR	TYPE OF INSURANCE	ADDL SUBR INSD WVD	POLICY NUMBER	POLICY EFF (MM/DD/YYYY)	POLICY EXP (MM/DD/YYYY)	LIMITS
A	<input checked="" type="checkbox"/> COMMERCIAL GENERAL LIABILITY <input type="checkbox"/> CLAIMS-MADE <input checked="" type="checkbox"/> OCCUR GEN'L AGGREGATE LIMIT APPLIES PER: <input checked="" type="checkbox"/> POLICY <input type="checkbox"/> PRO-JECT <input type="checkbox"/> LOC OTHER:	Y	UDC-4642447-CGL-21	10/27/2021	10/27/2022	EACH OCCURRENCE \$ 1,000,000
	DAMAGE TO RENTED PREMISES (Ea occurrence) \$ 100,000					
	MED EXP (Any one person) \$ 5,000					
	PERSONAL & ADV INJURY \$ 1,000,000					
						GENERAL AGGREGATE \$ 2,000,000
						PRODUCTS - COMP/OP AGG \$ S/T Gen. Agg.
						\$
	AUTOMOBILE LIABILITY <input type="checkbox"/> ANY AUTO <input type="checkbox"/> OWNED AUTOS ONLY <input type="checkbox"/> SCHEDULED AUTOS <input type="checkbox"/> HIRED AUTOS ONLY <input type="checkbox"/> NON-OWNED AUTOS ONLY <input type="checkbox"/> AUTOS ONLY					COMBINED SINGLE LIMIT (Ea accident) \$
						BODILY INJURY (Per person) \$
						BODILY INJURY (Per accident) \$
						PROPERTY DAMAGE (Per accident) \$
						\$
	<input type="checkbox"/> UMBRELLA LIAB <input type="checkbox"/> OCCUR <input type="checkbox"/> EXCESS LIAB <input type="checkbox"/> CLAIMS-MADE DED RETENTION \$					EACH OCCURRENCE \$
						AGGREGATE \$
						\$
	WORKERS COMPENSATION AND EMPLOYERS' LIABILITY ANY PROPRIETOR/PARTNER/EXECUTIVE OFFICER/MEMBER EXCLUDED? (Mandatory in NH) <input type="checkbox"/> If yes, describe under DESCRIPTION OF OPERATIONS below	N/A				<input type="checkbox"/> PER STATUTE <input type="checkbox"/> OTH-ER E.L. EACH ACCIDENT \$ E.L. DISEASE - EA EMPLOYEE \$ E.L. DISEASE - POLICY LIMIT \$

DESCRIPTION OF OPERATIONS / LOCATIONS / VEHICLES (ACORD 101, Additional Remarks Schedule, may be attached if more space is required)
 Trustees of Indiana University as additional insured

CERTIFICATE HOLDER

The Trustees Of Indiana University c/o Office of Insurance, Lost Control and Claims
 2805 E 10th St
 Bloomington, IN 47408

CANCELLATION

SHOULD ANY OF THE ABOVE DESCRIBED POLICIES BE CANCELLED BEFORE THE EXPIRATION DATE THEREOF, NOTICE WILL BE DELIVERED IN ACCORDANCE WITH THE POLICY PROVISIONS.

AUTHORIZED REPRESENTATIVE

© 1988-2015 ACORD CORPORATION. All rights reserved.

Business Details

Business Name: CUP OF JOY, LLP
Entity Type: Domestic Limited Liability Partnership
Creation Date: 09/13/2020
Principal Office Address: 7020 east state road 45, Bloomington, IN, 47408, USA
Jurisdiction of Formation: Indiana

Business ID: 202009131422496
Business Status: Active
Inactive Date:
Expiration Date: Perpetual
Business Entity Report Due Date: 09/30/2022
Years Due:

Principal Information

Title	Name	Address
Limited Partner	Amber Parker	5115 South College Drive, Bloomington, IN, 47403, USA

Registered Agent Information

Type: Individual
Name: Elizabeth Tragesser
Address: 7020 east state road 45, Bloomington, IN, 47408, USA

State of Indiana
Office of the Secretary of State

Certificate of Registration of Limited Liability Partnership
of
CUP OF JOY, LLP

I, CONNIE LAWSON, Secretary of State, hereby certify that a Registration of Limited Liability Partnership of the above Domestic Limited Liability Partnership has been presented to me at my office, accompanied by the fees prescribed by law and that the documentation presented conforms to law as prescribed by the provisions of the Indiana Code.

NOW, THEREFORE, with this document I certify that said transaction will become effective Sunday, September 13, 2020.

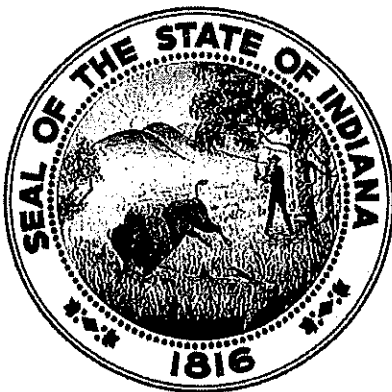

In Witness Whereof, I have caused to be affixed my signature and the seal of the State of Indiana, at the City of Indianapolis, September 14, 2020.

Connie Lawson

CONNIE LAWSON
SECRETARY OF STATE

202009131422496 / 8720472

To ensure the certificate's validity, go to <https://bsd.sos.in.gov/PublicBusinessSearch>



DEPARTMENT OF THE TREASURY
INTERNAL REVENUE SERVICE
CINCINNATI OH 45999-0023

Date of this notice: 09-17-2020

Employer Identification Number:
85-3058720

Form: SS-4

Number of this notice: CP 575 B

CUP OF JOY
ELIZABETH TRAGESSEY MBR
7020 E STATE ROAD 45
BLOOMINGTON, IN 47408

For assistance you may call us at:
1-800-829-4933

IF YOU WRITE, ATTACH THE
STUB AT THE END OF THIS NOTICE.

WE ASSIGNED YOU AN EMPLOYER IDENTIFICATION NUMBER

Thank you for applying for an Employer Identification Number (EIN). We assigned you EIN 85-3058720. This EIN will identify you, your business accounts, tax returns, and documents, even if you have no employees. Please keep this notice in your permanent records.

When filing tax documents, payments, and related correspondence, it is very important that you use your EIN and complete name and address exactly as shown above. Any variation may cause a delay in processing, result in incorrect information in your account, or even cause you to be assigned more than one EIN. If the information is not correct as shown above, please make the correction using the attached tear off stub and return it to us.

Based on the information received from you or your representative, you must file the following form(s) by the date(s) shown.

Form 1065

03/15/2021

If you have questions about the form(s) or the due date(s) shown, you can call us at the phone number or write to us at the address shown at the top of this notice. If you need help in determining your annual accounting period (tax year), see Publication 538, *Accounting Periods and Methods*.

We assigned you a tax classification based on information obtained from you or your representative. It is not a legal determination of your tax classification, and is not binding on the IRS. If you want a legal determination of your tax classification, you may request a private letter ruling from the IRS under the guidelines in Revenue Procedure 2004-1, 2004-1 I.R.B. 1 (or superseding Revenue Procedure for the year at issue). Note: Certain tax classification elections can be requested by filing Form 8832, *Entity Classification Election*. See Form 8832 and its instructions for additional information.

A limited liability company (LLC) may file Form 8832, *Entity Classification Election*, and elect to be classified as an association taxable as a corporation. If the LLC is eligible to be treated as a corporation that meets certain tests and it will be electing S corporation status, it must timely file Form 2553, *Election by a Small Business Corporation*. The LLC will be treated as a corporation as of the effective date of the S corporation election and does not need to file Form 8832.

To obtain tax forms and publications, including those referenced in this notice, visit our Web site at www.irs.gov. If you do not have access to the Internet, call 1-800-829-3676 (TTY/TDD 1-800-829-4059) or visit your local IRS office.





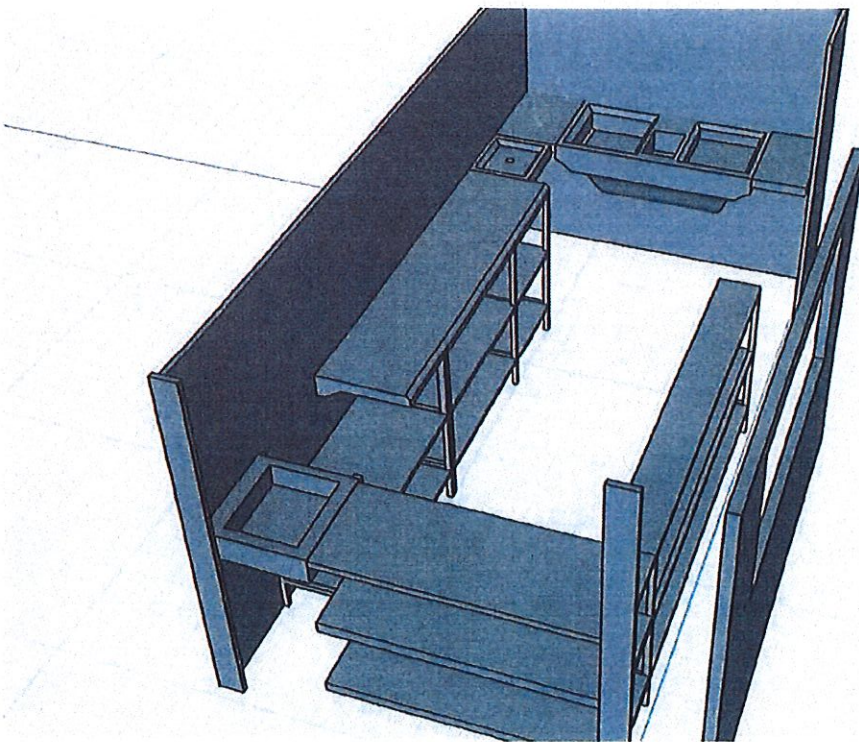
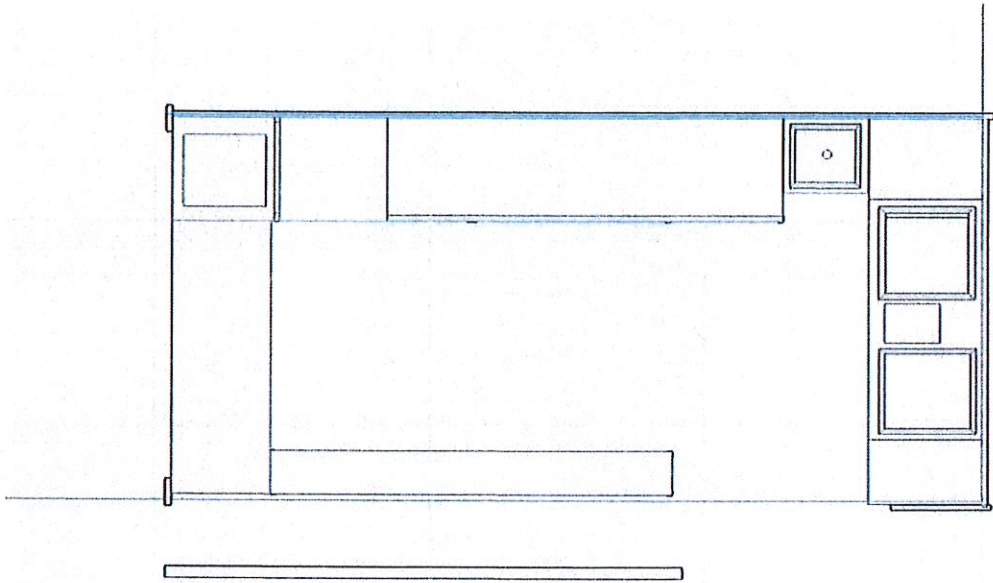



Certificate of Achievement



This certificate is awarded to
ELIZABETH TRAGESSE

Congratulations! You have completed
ServSafe® Food Handler
Employee Food Safety Online Course and Exam

National Restaurant Association
233 S. Wacker Drive, Suite 3600
Chicago, IL 60606-6383
800.765.2122 in Chicago area 312.715.1010
Restaurant.org | ServSafe.com

Certificate Number 5246078 Date 9/16/2021
Expiration Date 9/16/2024



Mobile Food Service Establishment License

Monroe County Health Department
Bloomington, IN 47404-3989
812-349-2542



CUP OF JOY
ELIZABETH TRAGESSER
ONE WORLD - 2361 RAPPEL AVENUE
BLOOMINGTON, IN 47404

2022

Having complied with the rules and regulations of the Monroe County Health Department as authorized by the Indiana Administrative Code and the Board of Commissioners of Monroe County, Indiana, is hereby authorized to operate a Food Service Establishment at the above location for the calendar year.

JAN 26 2022

Issued

By

Thomas W. Shapiro

PERMIT EXPIRES FEBRUARY 28, 2023

This License Is Not Transferable to Any Other Individual or Location

CITY OF BLOOMINGTON

MOBILE VENDOR INSPECTION CHECK SHEET

COMPANY PERFORMING INSPECTION High Speed Tire and Automotive Service

INSPECTOR'S NAME Scott Mullins INSPECTOR'S PHONE # 812-332-3331

DATE OF INSPECTION Sep 26 12

TAXICAB COMPANY _____

VEHICLE YEAR 1999 MAKE Chevy MODEL K1500

VIN 1GZLEK197L6VE258329

	PASS	FAIL	COMMENTS
LIGHTS (Front & Rear)	<input checked="" type="checkbox"/>	<input type="checkbox"/>	
FLASHERS	<input checked="" type="checkbox"/>	<input type="checkbox"/>	
REFLECTORS	<input checked="" type="checkbox"/>	<input type="checkbox"/>	
HORN	<input checked="" type="checkbox"/>	<input type="checkbox"/>	
WINDSHIELD WIPERS	<input checked="" type="checkbox"/>	<input type="checkbox"/>	
MIRRORS	<input checked="" type="checkbox"/>	<input type="checkbox"/>	
SEATBELTS	<input checked="" type="checkbox"/>	<input type="checkbox"/>	
BUMPER HEIGHT	<input checked="" type="checkbox"/>	<input type="checkbox"/>	
ALL WINDOWS	<input checked="" type="checkbox"/>	<input type="checkbox"/>	
MUFFLER	<input checked="" type="checkbox"/>	<input type="checkbox"/>	
TIRES	<input checked="" type="checkbox"/>	<input type="checkbox"/>	
BRAKES	<input checked="" type="checkbox"/>	<input type="checkbox"/>	
DOORS	<input checked="" type="checkbox"/>	<input type="checkbox"/>	
GENERAL CONDITION OF VEHICLE	<input checked="" type="checkbox"/>	<input type="checkbox"/>	

Attach this completed Inspection Sheet with your permit or renewal application
and remit to:
City of Bloomington
Department of Economic and Sustainable Development
401 N. Morton St.
Bloomington, Indiana 47404
812-349-3419

City of Bloomington
Fire Department

Mayor John Hamilton
Fire Chief Jason Moore

300 E 4th St
Bloomington IN 47402

(812) 332-9763
Fax (812) 332-9764

Temporary Food Vendor

Date: 09/27/2022

Business Name: Cup of Joy

Address: 6794 W VERNAL PIKE
Bloomington, IN 47404

Phone: CELL 812-272-7582

The following permit has been issued:

Permit No. 22-0230

Type: FOOD Temporary Vender/Cooking

Issued Date: 09/27/2022

Effective Date: 09/27/2022

Expiration Date: 09/27/2023

It is the business's responsibility to ensure that conditions are in accordance with applicable State and Local fire regulations. Please contact City of Bloomington Fire for more information.



Digitally signed by Tim Clapp
DN: C=US,
E=clapp@bloomington.in.gov,
O=Fire Marshall, CN=Tim Clapp
Date: 2022.09.27 12:37:47-0400'

Inspector: Tim Clapp

Date

**CITY OF BLOOMINGTON
BOARD OF PUBLIC WORKS
RESOLUTION 2022-79
Mobile Vendor in Public Right of Way
Cup of Joy**

WHEREAS, the Board of Public Works is empowered by Indiana Code § 36-9-6-2 to supervise the streets, alleys, sewers, public grounds, and other property of the City of Bloomington (“City”);

WHEREAS, Cup of Joy (“Vendor”), is seeking a Mobile Vendor License under Bloomington Municipal Code 4.28;

WHEREAS, the issuance of a Mobile Vendor License under Bloomington Municipal Code 4.28 requires Vendor to submit documentation to the City—set forth at Bloomington Municipal Code 4.28.050—including an independent safety inspection, an open burn permit issued by the City of Bloomington Fire Department, and all applicable permits required by the Monroe County Health Department;

WHEREAS, Vendor has agreed to the Standards of Conduct set forth in Bloomington Municipal Code 4.28.160 and signed the Release, Hold-Harmless, and Indemnification Agreement as required by Bloomington Municipal Code 4.28.090;

WHEREAS, Vendor desires to be able to use “City property” as defined in Bloomington Municipal Code 4.28.010, which includes public on-street parking, on a temporary and transient basis for the purpose of selling food via a mobile kitchen and food truck; and

WHEREAS, under the Bloomington Municipal Code, approval to use public on-street parking and sidewalks is provided by the Board of Public Works via resolution;

NOW, THEREFORE, BE IT RESOLVED BY THE BOARD OF PUBLIC WORKS THAT:

1. Vendor has permission to use on-street public parking and sidewalks, on a temporary and transient basis, for the purposes of selling food via a mobile kitchen and food truck for 1 year beginning on 10/10/2022, and ending on 10/10/2023.
2. For the avoidance of doubt, this Resolution is not the Business License referenced by Chapter 4.28 of the Bloomington Municipal Code. Thus, Vendor must ensure that all necessary documentation has been submitted to the City of Bloomington Controller and that the Business License has been issued by the City of Bloomington Controller before utilizing the permission to use on-street public parking and sidewalks granted in the paragraph above. Operating a mobile vendor without a business license is a violation of Bloomington Municipal Code 4.28.180(a)(1), and would subject Vendor to a fine of \$2,500 for the first offense.
3. For the avoidance of doubt, the following conditions—which in some instances may mirror those that exist under Title 4.28 of the Bloomington Municipal Code—attach to this approval:
 - a. Vendor agrees to maintain a clear five-foot path for pedestrians on the sidewalk at all times.
 - b. Vendor will have obtained a valid Mobile Vendor license issued by the City of Bloomington Controller prior to operation on City property, and will maintain a valid Mobile Vendor license throughout the term of Vendor’s operation on City property.
 - c. Vendor may locate his business in a public parking space within a reasonable time, no more than one hour, before the vendor begins selling food to persons. Vendor must still comply with all other restrictions regarding its location in a public parking space.

RESOLUTION 2022-79

- d. Vendor shall remove his business from a public parking space within a reasonable time, no more than one hour, following the time the vendor has stopped selling food to persons. Vendor must still comply with all other restrictions regarding its location in a public parking space.
- e. Vendor will comply with all other laws, ordinances, rules and regulations in effect at the time it conducts their business, including, but not limited to: (1) Bloomington Municipal Code 4.28 (Mobile Vendors), and (2) all City parking regulations, restrictions, and ordinances.
- f. Vendor is prohibited from operating within a one block radius of a Special Event, unless prior approval has been granted by either the operator of the Special Event or the City's Board of Public Works. The Board of Public Works is not required to provide specific notice to Vendor when it recognizes a Special Event. The following are Special Events that have been recognized by the Board of Public Works:
 - 1) City of Bloomington Farmers' Market;
 - 2) City of Bloomington Holiday Market;
 - 3) The Taste of Bloomington;
 - 4) Lotus World Music and Arts Festival;
 - 5) The Fourth Street Festival;
 - 6) Arts Fair on the Square;
 - 7) Strawberry Festival;
 - 8) Canopy of Lights;
 - 9) Fourth of July Parade; and
 - 10) Any other special events approved by the City Controller.

ADOPTED THIS THE 11th DAY OF OCTOBER, 2022.

BOARD OF PUBLIC WORKS:

Kyla Cox Deckard, President

Jennifer Lloyd, Vice-President

Elizabeth Karon, Secretary

ALL TERMS AND CONDITIONS CONTAINED IN THIS RESOLUTION 2022-79 ARE ACCEPTABLE AND AGREED TO BY VENDOR:

Elizabeth Tragesser

Date: _____



Board of Public Works Staff Report

Project/Event: Outdoor Lighting Service Agreements with Duke Energy

Petitioner/Representative: Department of Public Works

Staff Representative: Christina Smith

Meeting Date: October 11, 2022

Department of Public Works has received notification from Duke Energy that twenty-one (21) street lights along E 10th Street from N Walnut St to N Indiana Ave are approaching the end of their life. Due to the high costs of replacing all twenty-one (21) lights at one time, the City has decided to move forward with this project in phases. The following section will be replaced first as it's in the worst overall condition.

Phase 1 of this project will consist of the replacement of nine (9) street lights along the section of E 10th St from N Grant St to N Indiana Ave.

The City has elected to pay the total one time charge for equipment costs in the amount of \$46,813.41, and \$74.16 energy usage, and maintenance monthly costs. All of the associated costs with these lights will be paid out of the Local Road & Street Fund within the Street Operations Division's budget.

Summary of Contract: Phase 1 of the E 10th St (Walnut to Indiana) Replacement Project

Locations: E 10th St from N Grant St to N Indiana Ave

Fixture: Nine (9) 70 Watt LED Roadway fixtures

Pole: Nine (9) Spun aluminum poles

Funding Source: Local Roads and Streets Fund

Option A: \$46,813.41

Estimated Monthly Charge: \$74.16

City of Bloomington Contract and Purchase Justification Form

Vendor: Duke Energy

Contract Amount: \$46,813.41

This form should be completed and attached to the contract documents and forwarded to the Legal Department Attorney assigned to your Department. Contracts will not be approved by the Controller if a completed form is not included with the contract documents.

PURCHASE INFORMATION

1. Check the box beside the procurement method used to initiate this procurement: (Attach a quote or bid tabulation if applicable)

<input type="checkbox"/> Request for Quote (RFQ)	<input type="checkbox"/> Request for Proposal (RFP)	<input checked="" type="checkbox"/> Sole Source	<input type="checkbox"/> Not Applicable (NA)
<input type="checkbox"/> Invitation to Bid (ITB)	<input type="checkbox"/> Request for Qualifications (RFQu)	<input type="checkbox"/> Emergency Purchase	

2. List the results of procurement process. Give further explanation where requested. Yes No

# of Submittals:	Yes	No	Was the lowest cost selected? (If no, please state below why it was not.)	Yes	No
Met city requirements?	<input checked="" type="checkbox"/>	<input type="checkbox"/>		<input type="checkbox"/>	<input type="checkbox"/>
Met item or need requirements?	<input checked="" type="checkbox"/>	<input type="checkbox"/>			
Was an evaluation team used?	<input type="checkbox"/>	<input checked="" type="checkbox"/>			
Was scoring grid used?	<input type="checkbox"/>	<input checked="" type="checkbox"/>			
Were vendor presentations requested?	<input type="checkbox"/>	<input checked="" type="checkbox"/>			

3. State why this vendor was selected to receive the award and contract:

Duke Energy is a sole source provider for street light installation within the public right of way. The City leases street lights from Duke Energy and pays for the installation costs, energy, and maintenance costs with Duke providing the maintenance services. The City does not have the labor force or equipment necessary to provide maintenance services for over 3,000 street lights within the public right of way.

Christina Smith

Project Coordinator

Department of Public Works

Print/Type Name

Print/Type Title

Department

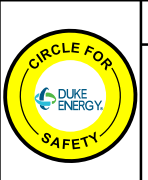

REMEMBER: Work zone area conditions may have changed for this job! Everyone is responsible for verifying the above safety information is correct prior to any work being performed each day.

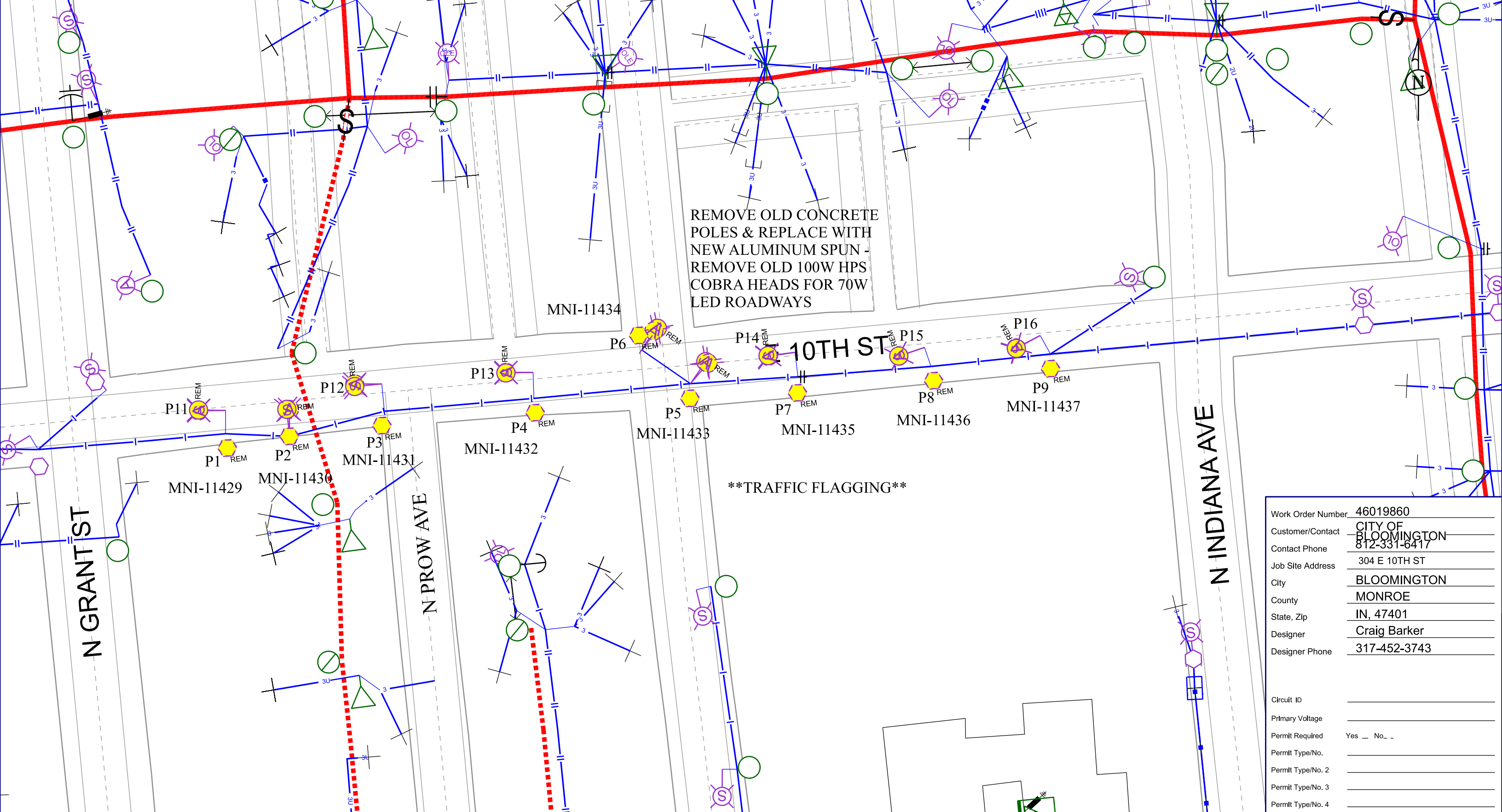

REMOVE OLD CONCRETE
 POLES & REPLACE WITH
 NEW ALUMINUM SPUN -
 REMOVE OLD 100W HPS
 COBRA HEADS FOR 70W
 LED ROADWAYS

****TRAFFIC FLAGGING****

Work Order Number	46019860
Customer/Contact	CITY OF BLOOMINGTON
Contact Phone	812-331-6417
Job Site Address	304 E 10TH ST
City	BLOOMINGTON
County	MONROE
State, Zip	IN, 47401
Designer	Craig Barker
Designer Phone	317-452-3743

Circuit ID	
Primary Voltage	
Permit Required	Yes _ No _
Permit Type/No.	
Permit Type/No. 2	
Permit Type/No. 3	
Permit Type/No. 4	

E-OH-PRIMARY--122FT-C
 POLE-765
 E-OH-TX-50 kVA-120/240 V-Single Phase-B
 ELBOW-LB-NORM CLOSED-ABC



IN01 LIGHTING SERVICE AGREEMENT

Account Information:
CITY OF BLOOMINGTON
PO BOX 100
BLOOMINGTON IN

Project Information:

Indiana

Account Number:

Work Order Number:
46019860

Customer Contact Information:
CITY OF BLOOMINGTON
SMITHC@BLOOMINGTON.IN.GOV

Duke Energy Representative Contact Info:

..

This Lighting Service Agreement is hereby entered into this 28th day of September, 2022, between Duke Energy (hereinafter called the “Company”) and CITY OF BLOOMINGTON (hereinafter referred to as the “Customer”) for lighting service at the above location(s). The Customer agrees to receive and pay for lighting service from the Company in accordance with the rates, terms and provisions of the Company’s Rate Schedule LED and Service Regulations, or its successor, as the same is on file with the Indiana Public Service Commission (INDIANA UTILITY REGULATORY COMMISSION) and as may be amended and subsequently filed with the INDIANA UTILITY REGULATORY COMMISSION.

To the extent there is any conflict between this Agreement and the Lighting Service Rate Schedule, the Lighting Service Rate Schedule shall control. In the event of termination by the Customer during the initial term of this agreement under this rate schedule or upon early termination of service under this schedule, the customer agrees to pay remaining terms of this agreement as delegated by the INDIANA UTILITY REGULATORY COMMISSION.

The date of *initiation* of service shall be defined as the date the first light(s) is energized or billing is transferred and shall continue hereafter until terminated *by either party upon written notice 22 days prior to termination*. It is further agreed that Duke Energy reserves the right to discontinue service and remove any Duke Energy-owned facilities from the Customers premise if the Customer violates any of the terms of the Service Regulations, Rate Schedule or this Agreement.

Customer Signature _____

Date Signed _____

Duke Energy Representative Craig Barker

Date Signed 9/28/2022

THIS IS NOT A BILL. PLEASE DO NOT SEND A PAYMENT IN RESPONSE TO THIS COMMUNICATION.



Summary of Estimated Charges				
Minimum Service Term	Initial Monthly Cost	Total One Time Charges	Total Cost for Initial term	Ongoing Monthly Charge post Term
0 Years () Months	74.16	46739.24	46739.24	74.16

Monthly Base Charges								
Service Required	Quantity	Product Description Fixtures and Poles	Equipment Rental**	Maintenance	Energy	Unit Total	Sub-Total	
I	009	LFIX-RW-LED-70-GRAY-III-3000K-M	5193.25	6.53	1.71	5201.49	46813.41	
		Rental, Maintenance, F&E Totals:	\$46,739.25	\$58.77	\$15.39			
		Estimated Change to Base Monthly Charge Total						\$46,813.41

THIS IS NOT A BILL. PLEASE DO NOT SEND A PAYMENT IN RESPONSE TO THIS COMMUNICATION.



Board of Public Works Staff Report

Project/Event: 2023 Service Contract with Tabor/Bruce Architecture & Design, Inc. for Design and Inspection Services

Petitioner/Representative: Public Works Facilities Division

Staff Representative: J. D. Boruff, Operations and Facilities Director

Meeting Date: October 11, 2022

This is a service agreement with Tabor/Bruce Architecture & Design, Inc. for Architectural and design services. The contract will also include building inspections and reports, such as due diligence inspections prior to building purchases.

Staff recommends awarding the service agreement to Tabor/Bruce Architecture & Design, Inc. not to exceed \$40,000.00.

Respectfully submitted,

A handwritten signature in black ink that reads "JD Boruff".

J. D. Boruff
Operations and Facilities Director
Public Works Department

City of Bloomington Contract and Purchase Justification Form

Vendor: Tabor/Bruce Architecture &

Contract Amount: Not to exceed \$40,000.00

This form should be completed and attached to the contract documents and forwarded to the Legal Department Attorney assigned to your Department. Contracts will not be approved by the Controller if a completed form is not included with the contract documents.

PURCHASE INFORMATION

1. Check the box beside the procurement method used to initiate this procurement: (Attach a quote or bid tabulation if applicable)

<input type="checkbox"/> Request for Quote (RFQ)	<input type="checkbox"/> Request for Proposal (RFP)	<input type="checkbox"/> Sole Source	<input checked="" type="checkbox"/> Not Applicable (NA)
<input type="checkbox"/> Invitation to Bid (ITB)	<input type="checkbox"/> Request for Qualifications (RFQu)	<input type="checkbox"/> Emergency Purchase	

2. List the results of procurement process. Give further explanation where requested. Yes No

# of Submittals: 1	Yes	No	Was the lowest cost selected? (If no, please state below why it was not.)	Yes	No
Met city requirements?	<input checked="" type="checkbox"/>	<input type="checkbox"/>	This is a service agreement not to exceed \$40,000.00. Contractor submitted rates of service and Public Works has agreed to enter into a service agreement with the contractor.	<input type="checkbox"/>	<input checked="" type="checkbox"/>
Met item or need requirements?	<input checked="" type="checkbox"/>	<input type="checkbox"/>			
Was an evaluation team used?	<input type="checkbox"/>	<input checked="" type="checkbox"/>			
Was scoring grid used?	<input type="checkbox"/>	<input checked="" type="checkbox"/>			
Were vendor presentations requested?	<input type="checkbox"/>	<input checked="" type="checkbox"/>			

3. State why this vendor was selected to receive the award and contract:

Tabor/Bruce Architecture & Design, Inc. has been our primary architectural consultant for several years. This agreement will allow them to consult on an as needed basis. Under this agreement they will also perform facility inspection and reporting services.

J. D. Boruff

Facilities Director

Public Works

Print/Type Name

Print/Type Title

Department

**AGREEMENT BETWEEN CITY OF BLOOMINGTON
PUBLIC WORKS DEPARTMENT AND
TABOR/BRUCE ARCHITECTURE & DESIGN, INC.**

This Agreement, entered into on this 11th day of October, 2022, by and between the City of Bloomington Department of Public Works (the “Department”), and Tabor/Bruce Architecture & Design, Inc. (“Contractor”).

Article 1. Scope of Services Contractor shall perform architectural design and drafting services, as well as facility inspections and subsequent reporting, at all facilities maintained by the Department. Contractor shall also act as a consultant for the Department to obtain various permits and approvals necessary for the construction or renovation of Department owned properties. These services will be performed at City facilities (“Services”) for a set price. These rates shall be One Hundred Fifty Eight Dollars (\$158.00) per hour for a Principal Architect, Eighty Five Dollars (\$85.00) per hour for staff Project Managers, and Fifty Eight Dollars (\$58.00) per hour for drafting services. Contractor shall also be reimbursed by the Department for reasonable travel expenses that they might incur.

Outside services and expenses incurred by the contractor shall be billed at contractor cost plus 15%. Contractor shall diligently provide the Services under this Agreement and shall complete the Services described in this Agreement in a timely manner consistent with the Standard of Care identified in Article 2. Contractor shall complete the Services required under this Agreement on or before Friday, December 31st, 2023, unless the parties mutually agree to a later completion date. Completion shall mean completion of all work related to the Services. In the performance of Contractor’s work, Contractor agrees to maintain such coordination with the Department as may be requested and desirable, including primary coordination with J. D. Boruff, Operations and Facilities Director, Public Works Department. Contractor agrees that any information or documents, including digital GIS information, supplied by the Department pursuant to Article 3, below, shall be used by Contractor for this project only, and shall not be reused or reassigned for any other purpose without the written permission of the Department.

Article 2. Standard of Care Contractor shall be responsible for completion of the Services in a manner consistent with that degree of care and skill ordinarily exercised by members of the same profession currently practicing under similar circumstances (“Standard of Care”). The Department shall be the sole judge of the adequacy of Contractor’s work in meeting the Standard of Care; however, the Department shall not unreasonably withhold its approval as to the adequacy of Contractor’s performance. Upon notice to Contractor and by mutual agreement between the parties, Contractor will, without additional compensation, correct or replace any and all Services not meeting the Standard of Care.

Article 3. Responsibilities of the Department The Department shall provide all necessary information regarding requirements for the Services. The Department shall furnish such information as necessary for the orderly progress of the work, and Contractor shall be entitled to rely upon the accuracy and completeness of such information. The Department’s Project Manager shall act on its behalf with respect to this Agreement.

Article 4. Compensation The Department shall pay Contractor for all fees and expenses in an amount not to exceed Forty Thousand Dollars (\$40,000.00). Contractor shall submit an invoice to the Department upon the completion of the Services described in Article 1. The invoice shall be sent to: J. D. Boruff, City of Bloomington Public Works, 401 N. Morton, Suite 120, Bloomington, Indiana 47404. Invoices may be sent via first class mail postage prepaid or via email. Payment will be remitted to Contractor within forty-five (45) days of receipt of invoice. Additional services not set forth in Article 1, or changes in the Services must be authorized in writing by the Department or its designated project coordinator prior to such work being performed, or expenses incurred. The Department shall not make payment for any unauthorized work or expenses.

Article 5. Appropriation of Funds Notwithstanding any other provision of this Agreement, if funds for the continued fulfillment of this Agreement by the Department are at any time not forthcoming or are insufficient, through failure of any entity, including the Department itself, to appropriate funds or otherwise, then the Department shall have the right to terminate this Agreement without penalty.

Article 6. Schedule Contractor shall perform the Services according to the following schedule: Services will be on as needed basis upon request of the Department. The time limits established by this schedule shall not be exceeded, except for reasonable cause as mutually agreed to by all parties.

Article 7. Termination In the event of a party's substantial failure to perform in accordance with the terms of this Agreement, the other party shall have the right to terminate the Agreement upon written notice. The nonperforming party shall have fourteen (14) calendar days from the receipt of the termination notice to cure or to submit a plan for cure acceptable to the other party. Additionally, the Department may terminate or suspend performance of this Agreement at the Department's prerogative at any time upon written notice to Contractor. Contractor shall terminate or suspend performance of the Services on a schedule acceptable to the Department and the Department shall pay the Contractor for all the Services performed up to the date that written notice is received, plus reasonable termination or suspension expenses. Upon restart, an equitable adjustment shall be made to Contractor's compensation and the schedule of services. Upon termination or suspension of this Agreement, all finished or unfinished reports, drawings, collections of data and other documents generated by Contractor in connection with this Agreement shall become the property of the Department, as set forth in Article 9 herein.

Article 8. Identity of the Contractor Contractor acknowledges that one of the primary reasons for its selection by the Department to perform the Services is the qualifications and experience of Contractor. Contractor thus agrees that the Services to be performed pursuant to this Agreement shall be performed by Contractor. Contractor shall not subcontract any part of the Services without the prior written permission of the Department. The Department reserves the right to reject any of the Contractor's personnel or proposed outside professional sub-Contractors, and the Department reserves the right to request that acceptable replacement personnel be assigned to the project.

Article 9. Ownership of Documents and Intellectual Property All documents, drawings and specifications, including digital format files, prepared by Contractor and furnished to the Department as part of the Services shall become the property of the Department. Contractor shall retain its ownership rights in its design, drawing details, specifications, databases, computer software and other proprietary property. Intellectual property developed, utilized or modified in the performance of the Services shall remain the property of Contractor.

Article 10. Independent Contractor Status During the entire term of this Agreement, Contractor shall be an independent contractor, and in no event shall any of its personnel, agents or sub-contractors be construed to be, or represent themselves to be, employees of the Department. Contractor shall be solely responsible for the payment and reporting of all employee and employer taxes, including social security, unemployment, and any other federal, state, or local taxes required to be withheld from employees or payable on behalf of employees.

Article 11. Indemnification Contractor shall defend, indemnify, and hold harmless the City of Bloomington, the Department, and the officers, agents and employees of the City and the Department from any and all claims, demands, damages, costs, expenses or other liability arising out of the Agreement or occasioned by the reckless or negligent performance of any provision thereof, including, but not limited to, any reckless or negligent act or failure to act or any misconduct on the part of the Contractor or its agents or employees, or any independent contractors directly responsible to it (collectively "Claims").

Article 12. Insurance During the performance of any and all Services under this Agreement, Contractor shall maintain the following insurance in full force and effect: a) General Liability Insurance, with a

minimum combined single limit of \$1,000,000 for each occurrence and \$2,000,000 in the aggregate; b) Automobile Liability Insurance, with a minimum combined single limit of \$1,000,000 for each person and \$1,000,000 for each accident; c) Workers' Compensation Insurance in accordance with the statutory requirements of Title 22 of the Indiana Code; and d) Professional Liability Insurance ("Errors and Omissions Insurance") with a minimum limit of \$1,000,000 annual aggregate. All insurance policies shall be issued by an insurance company authorized to issue such insurance in the State of Indiana. The City of Bloomington, the Department, and the officers, employees and agents of each shall be named as insureds under the General Liability, Automobile, and Worker's Compensation policies, and such policies shall stipulate that the insurance will operate as primary insurance and that no other insurance of the City's will be called upon to contribute to a loss hereunder. Contractor shall provide evidence of each insurance policy to the Department prior to the commencement of work under this Agreement.

Article 13. Conflict of Interest Contractor declares that it has no present interest, nor shall it acquire any interest, direct or indirect, which would conflict with the performance of Services under this Agreement. Contractor agrees that no person having any such interest shall be employed in the performance of this Agreement.

Article 14. Waiver No failure of either party to enforce a term of this Agreement against the other shall be construed as a waiver of that term, nor shall it in any way affect the party's right to enforce that term. No waiver by any party of any term of this Agreement shall be considered to be a waiver of any other term or breach thereof.

Article 15. Severability The invalidity, illegality or unenforceability of any provision of this Agreement or the occurrence of any event rendering any portion or provision of this Agreement void shall in no way affect the validity or enforceability of any other portion or provision of this Agreement. Any void provision shall be deemed severed from this Agreement, and the balance of the Agreement shall be construed and enforced as if it did not contain the particular provision to be held void. The parties further agree to amend this Agreement to replace any stricken provision with a valid provision that comes as close as possible to the intent of the stricken provision. The provisions of this Article shall not prevent this entire Agreement from being void should a provision which is of the essence of this Agreement be determined void.

Article 16. Assignment Neither the Department nor the Contractor shall assign any rights or duties under this Agreement without the prior written consent of the other party. Unless otherwise stated in the written consent to an assignment, no assignment will release or discharge the assignor from any obligation under this Agreement.

Article 17. Third Party Rights Nothing in this Agreement shall be construed to give any rights or benefits to anyone other than the parties.

Article 18. Governing Law and Venue This Agreement shall be governed by the laws of the State of Indiana. Venue of any disputes arising under this Agreement shall be in the Monroe Circuit Court, Monroe County, Indiana.

Article 19. Non-Discrimination Contractor shall comply with City of Bloomington Ordinance 2.21.020 and all other federal, state and local laws and regulations governing non-discrimination in all regards, including, but not limited to, employment.

Article 20. Compliance with Laws In performing the Services under this Agreement, Contractor shall comply with any and all applicable federal, state and local statutes, ordinances, plans and regulations, including any and all regulations for protection of the environment. Where such statutes, ordinances, plans or regulations of any public authority having any jurisdiction over the project are in conflict, Contractor shall proceed using its best judgment only after attempting to resolve any such conflict between such

governmental agencies, and shall notify the Department in a timely manner of the conflict, attempts of resolution, and planned course of action.

Article 21. E-Verify Contractor is required to enroll in and verify the work eligibility status of all newly-hired employees through the E-Verify program. (This is not required if the E-Verify program no longer exists). Contractor shall sign an affidavit, attached as Exhibit A, affirming that Contractor does not knowingly employ an unauthorized alien. Contractor shall require any subcontractors performing work under this contract to certify to the Contractor that, at the time of certification, the subcontractor does not knowingly employ or contract with an unauthorized alien and the subcontractor has enrolled in and is participating in the E-Verify program. Contractor shall maintain on file all subcontractors' certifications throughout the term of the contract with the City.

Article 22. Notices Any notice required by this Agreement shall be made in writing to the individuals/addresses specified below:

Department: City of Bloomington Public Works, Attn: J.D. Boruff, 401 N. Morton, Suite 120, Bloomington, Indiana 47404.

Contractor: Tabor/Bruce Architecture & Design, Inc., Attn: Doug Bruce, 1101 South Walnut Street, Bloomington Indiana 47401.

Nothing contained in this Article shall be construed to restrict the transmission of routine communications between representatives of the Department and Contractor.

Article 23. Integration and Modification This Agreement, including all Exhibits incorporated by reference, represents the entire and integrated agreement between the Department and the Contractor. It supersedes all prior and contemporaneous communications, representations and agreements, whether oral or written, relating to the subject matter of this Agreement. This Agreement may be modified only by a written amendment signed by both parties hereto.

Article 24. Non-Collusion Contractor is required to certify that it has not, nor has any other member, representative, or agent of Contractor, entered into any combination, collusion, or agreement with any person relative to the price to be offered by any person nor prevented any person from making an offer nor induced anyone to refrain from making an offer and that this offer is made without reference to any other offer. Contractor shall sign an affidavit, attached hereto as Exhibit B, affirming that Contractor has not engaged in any collusive conduct. Exhibit B is attached hereto and incorporated by reference as though fully set forth.

Article 25: Renewal This Agreement may be renewed for three additional one-year terms so long as none of the terms and conditions herein are modified in any way. Renewal shall only occur upon advanced written notice by the City to the Contractor that the City wishes to renew the Agreement at least thirty (30) days, but not more than sixty (60) days, prior to the end of the current term

CITY OF BLOOMINGTON

Tabor/Bruce Architecture & Design, Inc.

Beth Cate, Corporation Counsel

Doug Bruce, Owner

CITY OF BLOOMINGTON PUBLIC WORKS

Adam Wason, Director

Kyla Cox Deckard, President, Board of Public Works

EXHIBIT B

STATE OF INDIANA)
) SS:
COUNTY OF _____)

NON-COLLUSION AFFIDAVIT

The undersigned offeror or agent, being duly sworn on oath, says that he has not, nor has any other member, representative, or agent of the firm, company, corporation or partnership represented by him, entered into any combination, collusion or agreement with any person relative to the price to be offered by any person nor to prevent any person from making an offer nor to induce anyone to refrain from making an offer and that this offer is made without reference to any other offer.

OATH AND AFFIRMATION

I affirm under the penalties of perjury that the foregoing facts and information are true and correct to the best of my knowledge and belief.

Dated this _____ day of _____, 2022.

Tabor/Bruce Architecture & Design

By: _____

STATE OF INDIANA)
) SS:
COUNTY OF _____)

Before me, a Notary Public in and for said County and State, personally appeared _____ and acknowledged the execution of the foregoing this _____ day of _____, 2022.

Notary Public's Signature My Commission Expires: _____

Printed Name of Notary Public County of Residence: _____

Commission Number



Board of Public Works Staff Report

Project/Event: Supplement #1 to Service Agreement with Harrell-Fish, Inc.,
for HVAC Maintenance and Repair Services

Petitioner/Representative: Public Works Facilities Division

Staff Representative: J. D. Boruff, Operations and Facilities Director

Meeting Date: October 11, 2022

This supplement is being requested for the increase of the original not to exceed amount of \$145,000. The supplement we're requesting would be an additional \$10,000. This Supplement #1 increases the not to exceed amount of the Agreement to \$155,000.00. When determining the original "not to exceed" amount for the original agreement, we underestimated the amount of work we would have for this contractor to perform.

Respectfully submitted,

A handwritten signature in black ink that reads "J. D. Boruff".

J. D. Boruff
Operations and Facilities Director
Public Works Department

City of Bloomington Contract and Purchase Justification Form

Vendor: Harrell-Fish, Inc.

Contract Amount: \$10,000

This form should be completed and attached to the contract documents and forwarded to the Legal Department Attorney assigned to your Department. Contracts will not be approved by the Controller if a completed form is not included with the contract documents.

PURCHASE INFORMATION

1. Check the box beside the procurement method used to initiate this procurement: (Attach a quote or bid tabulation if applicable)

<input type="checkbox"/> Request for Quote (RFQ)	<input type="checkbox"/> Request for Proposal (RFP)	<input type="checkbox"/> Sole Source	<input checked="" type="checkbox"/> Not Applicable (NA)
<input type="checkbox"/> Invitation to Bid (ITB)	<input type="checkbox"/> Request for Qualifications (RFQu)	<input type="checkbox"/> Emergency Purchase	

2. List the results of procurement process. Give further explanation where requested. Yes No

# of Submittals: 0		Yes	No	
Met city requirements?	<input type="checkbox"/>	<input type="checkbox"/>		Was the lowest cost selected? (If no, please state below why it was not.) <input type="checkbox"/> Yes <input checked="" type="checkbox"/> No
Met item or need requirements?	<input type="checkbox"/>	<input type="checkbox"/>		This is a supplement to an existing service agreement
Was an evaluation team used?	<input type="checkbox"/>	<input type="checkbox"/>		
Was scoring grid used?	<input type="checkbox"/>	<input type="checkbox"/>		
Were vendor presentations requested?	<input type="checkbox"/>	<input type="checkbox"/>		

3. State why this vendor was selected to receive the award and contract:

This is a supplement to an an existing service agreement that was approved by the Board of Public Works on November 9th, 2021. We are adding an additional \$10,000 to the HVAC service agreement with HFI.

JD Boruff

Print/Type Name

Director of Facilities

Print/Type Title

Public Works

Department

**SUPPLEMENT #1 TO 2022 SERVICE AGREEMENT
BETWEEN
CITY OF BLOOMINGTON
AND
HARRELL-FISH, INC.**

This Supplement #1 increases the Not to Exceed amount of compensation allowed under this Service Agreement as follows:

1. On November 9, 2021, the Board of Public Works approved the 2022 Service Agreement with Harrell-Fish, Inc.
2. The original contract underestimated the amount of work that would be necessary pursuant to the Service Agreement.
3. **Article 4. Compensation** contained the not to exceed amount of compensation that was originally allowed under this Service Agreement as \$145,000.00. This Supplement #1 adds \$10,000 in compensation, for a revised NTE cost of \$155,000.00 for this 2022 Service Agreement.
4. In all other respects, the Agreement shall remain in effect as originally written.

IN WITNESS WHEREOF, the parties have caused this Supplement #1 to be executed the day and year last written below:

CITY OF BLOOMINGTON

HARRELL-FISH, INC.

By: _____
Kyla Cox Deckard, President
Board of Public Works

By: _____

Name and Title

Date: _____

Date: _____

By: _____
Adam Wason, Director
Public Works Department

Date: _____

By: _____
John Hamilton, Mayor

Date: _____

**AGREEMENT BETWEEN CITY OF BLOOMINGTON
PUBLIC WORKS DEPARTMENT AND
HARRELL-FISH, INC.**

This Agreement, entered into on this 9th day of November, 2021, by and between the City of Bloomington Department of Public Works (the “Department”), and Harrell-Fish, Inc. (“Contractor”).

Article 1. Scope of Services Contractor shall perform repair and preventative maintenance services on HVAC systems and equipment at all facilities maintained by the Department. These services will be performed at City facilities (“Services”) for a set price of Eighty-Four Dollars (\$84.00) per hour, per person during the hours of Monday-Friday 7:00 am – 3:30 pm. Any work performed Monday-Friday 3:30 pm to 7:00 am, and on Saturdays, will have a set price of Ninety-Nine Dollars (\$99.00) per, per person. Any work performed on Sundays, or on a recognized holiday, will be performed at the rate of One Hundred Twenty Dollars (\$120.00) per hour, per person. Contractor shall diligently provide the Services under this Agreement and shall complete the Services described in this Agreement in a timely manner consistent with the Standard of Care identified in Article 2. Contractor shall complete the Services required under this Agreement on or before December 31st, 2022, unless the parties mutually agree to a later completion date. Completion shall mean completion of all work related to the Services. In the performance of Contractor’s work, Contractor agrees to maintain such coordination with the Department as may be requested and desirable, including primary coordination with J. D. Boruff, Operations and Facilities Director, Public Works Department. Contractor agrees that any information or documents, including digital GIS information, supplied by the Department pursuant to Article 3, below, shall be used by Contractor for this project only, and shall not be reused or reassigned for any other purpose without the written permission of the Department.

Article 2. Standard of Care Contractor shall be responsible for completion of the Services in a manner consistent with that degree of care and skill ordinarily exercised by members of the same profession currently practicing under similar circumstances (“Standard of Care”). The Department shall be the sole judge of the adequacy of Contractor’s work in meeting the Standard of Care; however, the Department shall not unreasonably withhold its approval as to the adequacy of Contractor’s performance. Upon notice to Contractor and by mutual agreement between the parties, Contractor will, without additional compensation, correct or replace any and all Services not meeting the Standard of Care.

Article 3. Responsibilities of the Department The Department shall provide all necessary information regarding requirements for the Services. The Department shall furnish such information as necessary for the orderly progress of the work, and Contractor shall be entitled to rely upon the accuracy and completeness of such information. The Department’s Project Manager shall act on its behalf with respect to this Agreement.

Article 4. Compensation The Department shall pay Contractor for all fees and expenses in an amount not to exceed One Hundred Forty-Five Thousand Dollars (\$145,000.00). Contractor shall submit an invoice to the Department upon the completion of the Services described in Article 1. **Invoices shall be sent via email to publicworks@bloomington.in.gov or via first class mail postage prepaid to Public Works Department, 401 N. Morton Street, Suite 120, Bloomington, IN 47404.** Payment will be remitted to Contractor within forty-five (45) days of receipt of invoice. Additional services not set forth in Article 1, or changes in the Services must be authorized in writing by the Department or its designated project coordinator prior to such work being performed, or expenses incurred. The Department shall not make payment for any unauthorized work or expenses.

Article 5. Appropriation of Funds Notwithstanding any other provision of this Agreement, if funds for the continued fulfillment of this Agreement by the Department are at any time not forthcoming or are insufficient, through failure of any entity, including the Department itself, to appropriate funds or otherwise, then the Department shall have the right to terminate this Agreement without penalty.

Article 6. Schedule Contractor shall perform the Services according to the following schedule: Services will be on as needed basis upon request of the Department. The time limits established by this schedule shall not be exceeded, except for reasonable cause as mutually agreed to by all parties.

Article 7. Termination In the event of a party's substantial failure to perform in accordance with the terms of this Agreement, the other party shall have the right to terminate the Agreement upon written notice. The nonperforming party shall have fourteen (14) calendar days from the receipt of the termination notice to cure or to submit a plan for cure acceptable to the other party. Additionally, the Department may terminate or suspend performance of this Agreement at the Department's prerogative at any time upon written notice to Contractor. Contractor shall terminate or suspend performance of the Services on a schedule acceptable to the Department and the Department shall pay the Contractor for all the Services performed up to the date that written notice is received, plus reasonable termination or suspension expenses. Upon restart, an equitable adjustment shall be made to Contractor's compensation and the schedule of services. Upon termination or suspension of this Agreement, all finished or unfinished reports, drawings, collections of data and other documents generated by Contractor in connection with this Agreement shall become the property of the Department, as set forth in Article 9 herein.

Article 8. Identity of the Contractor Contractor acknowledges that one of the primary reasons for its selection by the Department to perform the Services is the qualifications and experience of Contractor. Contractor thus agrees that the Services to be performed pursuant to this Agreement shall be performed by Contractor. Contractor shall not subcontract any part of the Services without the prior written permission of the Department. The Department reserves the right to reject any of the Contractor's personnel or proposed outside professional sub-Contractors, and the Department reserves the right to request that acceptable replacement personnel be assigned to the project.

Article 9. Ownership of Documents and Intellectual Property All documents, drawings and specifications, including digital format files, prepared by Contractor and furnished to the Department as part of the Services shall become the property of the Department. Contractor shall retain its ownership rights in its design, drawing details, specifications, databases, computer software and other proprietary property. Intellectual property developed, utilized or modified in the performance of the Services shall remain the property of Contractor.

Article 10. Independent Contractor Status During the entire term of this Agreement, Contractor shall be an independent contractor, and in no event shall any of its personnel, agents or sub-contractors be construed to be, or represent themselves to be, employees of the Department. Contractor shall be solely responsible for the payment and reporting of all employee and employer taxes, including social security, unemployment, and any other federal, state, or local taxes required to be withheld from employees or payable on behalf of employees.

Article 11. Indemnification Contractor shall defend, indemnify, and hold harmless the City of Bloomington, the Department, and the officers, agents and employees of the City and the Department from any and all claims, demands, damages, costs, expenses or other liability arising out of the Agreement or occasioned by the reckless or negligent performance of any provision thereof, including, but not limited to, any reckless or negligent act or failure to act or any misconduct on the part of the Contractor or its agents or employees, or any independent contractors directly responsible to it (collectively "Claims").

Article 12. Insurance During the performance of any and all Services under this Agreement, Contractor shall maintain the following insurance in full force and effect: a) General Liability Insurance, with a minimum combined single limit of \$1,000,000 for each occurrence and \$2,000,000 in the aggregate; b) Automobile Liability Insurance, with a minimum combined single limit of \$1,000,000 for each person and \$1,000,000 for each accident; c) Workers' Compensation Insurance in accordance with the statutory requirements of Title 22 of the Indiana Code; and d) Professional Liability Insurance ("Errors and

Omissions Insurance”) with a minimum limit of \$1,000,000 annual aggregate. All insurance policies shall be issued by an insurance company authorized to issue such insurance in the State of Indiana. The City of Bloomington, the Department, and the officers, employees and agents of each shall be named as insureds under the General Liability, Automobile, and Worker’s Compensation policies, and such policies shall stipulate that the insurance will operate as primary insurance and that no other insurance of the City’s will be called upon to contribute to a loss hereunder. Contractor shall provide evidence of each insurance policy to the Department prior to the commencement of work under this Agreement.

Article 13. Conflict of Interest Contractor declares that it has no present interest, nor shall it acquire any interest, direct or indirect, which would conflict with the performance of Services under this Agreement. Contractor agrees that no person having any such interest shall be employed in the performance of this Agreement.

Article 14. Waiver No failure of either party to enforce a term of this Agreement against the other shall be construed as a waiver of that term, nor shall it in any way affect the party’s right to enforce that term. No waiver by any party of any term of this Agreement shall be considered to be a waiver of any other term or breach thereof.

Article 15. Severability The invalidity, illegality or unenforceability of any provision of this Agreement or the occurrence of any event rendering any portion or provision of this Agreement void shall in no way affect the validity or enforceability of any other portion or provision of this Agreement. Any void provision shall be deemed severed from this Agreement, and the balance of the Agreement shall be construed and enforced as if it did not contain the particular provision to be held void. The parties further agree to amend this Agreement to replace any stricken provision with a valid provision that comes as close as possible to the intent of the stricken provision. The provisions of this Article shall not prevent this entire Agreement from being void should a provision which is of the essence of this Agreement be determined void.

Article 16. Assignment Neither the Department nor the Contractor shall assign any rights or duties under this Agreement without the prior written consent of the other party. Unless otherwise stated in the written consent to an assignment, no assignment will release or discharge the assignor from any obligation under this Agreement.

Article 17. Third Party Rights Nothing in this Agreement shall be construed to give any rights or benefits to anyone other than the parties.

Article 18. Governing Law and Venue This Agreement shall be governed by the laws of the State of Indiana. Venue of any disputes arising under this Agreement shall be in the Monroe Circuit Court, Monroe County, Indiana.

Article 19. Non-Discrimination Contractor shall comply with City of Bloomington Ordinance 2.21.020 and all other federal, state and local laws and regulations governing non-discrimination in all regards, including, but not limited to, employment. Contractor understands that the City of Bloomington prohibits its employees from engaging in harassment or discrimination of any kind, including harassing or discriminating against independent contractors doing work for the City. If the Contractor believes that a City employee engaged in such conduct towards Contractor and/or any of its employees, Contractor or its employees may file a complaint with the City department head in charge of the Contractor’s work and/or with the City human resources department or the Bloomington Human Rights Commission. The City takes all complaints of harassment and discrimination seriously and will take appropriate disciplinary action if it finds that any City employee engaged in such prohibited conduct.

Article 20. Compliance with Laws In performing the Services under this Agreement, Contractor shall comply with any and all applicable federal, state and local statutes, ordinances, plans and regulations, including any and all regulations for protection of the environment. Where such statutes, ordinances, plans or regulations of any public authority having any jurisdiction over the project are in conflict, Contractor shall proceed using its best judgment only after attempting to resolve any such conflict between such governmental agencies, and shall notify the Department in a timely manner of the conflict, attempts of resolution, and planned course of action.

Article 21. E-Verify Contractor is required to enroll in and verify the work eligibility status of all newly-hired employees through the E-Verify program. (This is not required if the E-Verify program no longer exists). Contractor shall sign an affidavit, attached as Exhibit A, affirming that Contractor does not knowingly employ an unauthorized alien. Contractor shall require any subcontractors performing work under this contract to certify to the Contractor that, at the time of certification, the subcontractor does not knowingly employ or contract with an unauthorized alien and the subcontractor has enrolled in and is participating in the E-Verify program. Contractor shall maintain on file all subcontractors' certifications throughout the term of the contract with the City.

Article 22. Notices Any notice required by this Agreement shall be made in writing to the individuals/addresses specified below:

Department: City of Bloomington Public Works, Attn: J.D. Boruff, 401 N. Morton, Suite 120, Bloomington, Indiana 47404.

Contractor: Harrell-Fish, Inc., P.O. Box 1998., Bloomington Indiana 47402.

Nothing contained in this Article shall be construed to restrict the transmission of routine communications between representatives of the Department and Contractor.

Article 23. Integration and Modification This Agreement, including all Exhibits incorporated by reference, represents the entire and integrated agreement between the Department and the Contractor. It supersedes all prior and contemporaneous communications, representations and agreements, whether oral or written, relating to the subject matter of this Agreement. This Agreement may be modified only by a written amendment signed by both parties hereto.

Article 24. Non-Collusion Contractor is required to certify that it has not, nor has any other member, representative, or agent of Contractor, entered into any combination, collusion, or agreement with any person relative to the price to be offered by any person nor prevented any person from making an offer nor induced anyone to refrain from making an offer and that this offer is made without reference to any other offer. Contractor shall sign an affidavit, attached hereto as Exhibit B, affirming that Contractor has not engaged in any collusive conduct. Exhibit B is attached hereto and incorporated by reference as though fully set forth.

Article 25: Renewal This Agreement may be renewed for three additional one-year terms so long as none of the terms and conditions herein are modified in any way. Renewal shall only occur upon advanced written notice by the City to the Contractor that the City wishes to renew the Agreement at least thirty (30) days, but not more than sixty (60) days, prior to the end of the current term.

CITY OF BLOOMINGTON

Harrell-Fish, Inc.

John Hamilton, Mayor

Steve Dawson, President

CITY OF BLOOMINGTON PUBLIC WORKS

Adam Wason, Director

Dana Henke, President, Board of Public Works

EXHIBIT B

STATE OF INDIANA)
) SS:
COUNTY OF _____)

NON-COLLUSION AFFIDAVIT

The undersigned offeror or agent, being duly sworn on oath, says that he has not, nor has any other member, representative, or agent of the firm, company, corporation or partnership represented by him, entered into any combination, collusion or agreement with any person relative to the price to be offered by any person nor to prevent any person from making an offer nor to induce anyone to refrain from making an offer and that this offer is made without reference to any other offer.

OATH AND AFFIRMATION

I affirm under the penalties of perjury that the foregoing facts and information are true and correct to the best of my knowledge and belief.

Dated this _____ day of _____, 20__.

Harrell-Fish, Inc.

By: _____

STATE OF INDIANA)
) SS:
COUNTY OF _____)

Before me, a Notary Public in and for said County and State, personally appeared _____ and acknowledged the execution of the foregoing this _____ day of _____, 20__.

Notary Public's Signature My Commission Expires: _____

Printed Name of Notary Public County of Residence: _____

My Commission #: _____



Board of Public Works Staff Report

Project/Event: Supplement #2 to Service Agreement with Harrell-Fish, Inc.,
for Plumbing Maintenance and Repair Services

Petitioner/Representative: Public Works Facilities Division

Staff Representative: J. D. Boruff, Operations and Facilities Director

Meeting Date: October 11, 2022

This supplement is being requested for the increase of the previous not to exceed amount of \$70,000. The supplement we're requesting would be an additional \$20,000. This Supplement #2 increases the not to exceed amount of the Agreement to \$90,000.00. After increasing an additional \$10,000 on August 30th, we underestimated the amount of plumbing work remaining.

Respectfully submitted,

A handwritten signature in black ink that reads "JD Boruff".

J. D. Boruff
Operations and Facilities Director
Public Works Department

City of Bloomington Contract and Purchase Justification Form

Vendor: Harrell-Fish, Inc.

Contract Amount: \$20,000

This form should be completed and attached to the contract documents and forwarded to the Legal Department Attorney assigned to your Department. Contracts will not be approved by the Controller if a completed form is not included with the contract documents.

PURCHASE INFORMATION

1. Check the box beside the procurement method used to initiate this procurement: (Attach a quote or bid tabulation if applicable)

<input type="checkbox"/> Request for Quote (RFQ)	<input type="checkbox"/> Request for Proposal (RFP)	<input type="checkbox"/> Sole Source	<input checked="" type="checkbox"/> Not Applicable (NA)
<input type="checkbox"/> Invitation to Bid (ITB)	<input type="checkbox"/> Request for Qualifications (RFQu)	<input type="checkbox"/> Emergency Purchase	

2. List the results of procurement process. Give further explanation where requested.

	Yes	No		Yes	No
# of Submittals: 0			Was the lowest cost selected? (If no, please state below why it was not.)	<input type="checkbox"/>	<input checked="" type="checkbox"/>
Met city requirements?	<input type="checkbox"/>	<input type="checkbox"/>	This is a supplement to an existing service agreement		
Met item or need requirements?	<input type="checkbox"/>	<input type="checkbox"/>			
Was an evaluation team used?	<input type="checkbox"/>	<input type="checkbox"/>			
Was scoring grid used?	<input type="checkbox"/>	<input type="checkbox"/>			
Were vendor presentations requested?	<input type="checkbox"/>	<input type="checkbox"/>			

3. State why this vendor was selected to receive the award and contract:

This supplement is being requested for the increase of the previous not to exceed amount of \$70,000. The supplement we're requesting would be an additional \$20,000. This Supplement #2 increases the not to exceed amount of the Agreement to \$90,000.00. After increasing an additional \$10,000 on August 30th, we underestimated the amount of plumbing work remaining.

 JD Boruff

 Director of Facilities

 Public Works

Print/Type Name

Print/Type Title

Department

**SUPPLEMENT #2 TO 2022 SERVICE AGREEMENT
BETWEEN
CITY OF BLOOMINGTON
AND
HARRELL-FISH, INC.**

This Supplement #2 increases the Not to Exceed amount of compensation allowed under this Service Agreement as follows:

1. On August 30, 2022, the Board of Public Works approved Supplement #1 to the 2022 Services Agreement with Harrell-Fish, Inc.
2. The original contract underestimated the amount of work that would be necessary pursuant to the Service Agreement.
3. **Article 4. Compensation** contained the not to exceed amount of compensation that was originally allowed under this Service Agreement as \$60,000.00. Supplement #1 added \$10,000 in compensation, for a revised NTE cost of \$70,000.00 for this 2022 Service Agreement. Supplement #2 will add an additional \$20,000 in compensation, for a revised NTE cost of \$90,000.00.
4. In all other respects, the Agreement shall remain in effect as originally written.

IN WITNESS WHEREOF, the parties have caused this Supplement #2 to be executed the day and year last written below:

CITY OF BLOOMINGTON

HARRELL-FISH, INC.

By: _____
Kyla Cox Deckard, President
Board of Public Works

By: _____

Name and Title

Date: _____

Date: _____

By: _____
Adam Wason, Director
Public Works Department

Date: _____

By: _____
John Hamilton, Mayor

Date: _____

**AGREEMENT BETWEEN CITY OF BLOOMINGTON
PUBLIC WORKS DEPARTMENT AND
HARRELL-FISH, INC.**

This Agreement, entered into on this 09th day of November, 2021, by and between the City of Bloomington Department of Public Works (the “Department”), and Harrell-Fish, Inc. (“Contractor”).

Article 1. Scope of Services Contractor shall perform repair and inspection services on plumbing systems at all facilities maintained by the Department. These services will be performed at City facilities (“Services”) for a set price of Eighty-Four Dollars (\$84.00) per hour, per person during the hours of Monday-Friday 7:00 am – 3:30 pm. Any work performed Monday-Friday 3:30 pm to 7:00 am, and on Saturdays, will have a set price of Ninety-Nine Dollars (\$99.00) per hour, per person. Any work performed on Sundays, or on a recognized holiday, will be performed at the rate of One Hundred Thirty-Five (\$135.00.00) per hour, per person. Contractor shall diligently provide the Services under this Agreement and shall complete the Services described in this Agreement in a timely manner consistent with the Standard of Care identified in Article 2. Contractor shall complete the Services required under this Agreement on or before December 31st, 2022, unless the parties mutually agree to a later completion date. Completion shall mean completion of all work related to the Services. In the performance of Contractor’s work, Contractor agrees to maintain such coordination with the Department as may be requested and desirable, including primary coordination with J. D. Boruff, Operations and Facilities Director, Public Works Department. Contractor agrees that any information or documents, including digital GIS information, supplied by the Department pursuant to Article 3, below, shall be used by Contractor for this project only, and shall not be reused or reassigned for any other purpose without the written permission of the Department.

Article 2. Standard of Care Contractor shall be responsible for completion of the Services in a manner consistent with that degree of care and skill ordinarily exercised by members of the same profession currently practicing under similar circumstances (“Standard of Care”). The Department shall be the sole judge of the adequacy of Contractor’s work in meeting the Standard of Care; however, the Department shall not unreasonably withhold its approval as to the adequacy of Contractor’s performance. Upon notice to Contractor and by mutual agreement between the parties, Contractor will, without additional compensation, correct or replace any and all Services not meeting the Standard of Care.

Article 3. Responsibilities of the Department The Department shall provide all necessary information regarding requirements for the Services. The Department shall furnish such information as necessary for the orderly progress of the work, and Contractor shall be entitled to rely upon the accuracy and completeness of such information. The Department’s Project Manager shall act on its behalf with respect to this Agreement.

Article 4. Compensation The Department shall pay Contractor for all fees and expenses in an amount not to exceed Sixty Thousand Dollars (\$60,000.00). Contractor shall submit an invoice to the Department upon the completion of the Services described in Article 1. The invoice shall be sent to: **Invoices shall be sent via email to publicworks@bloomington.in.gov or via first class mail postage prepaid to Public Works Department, 401 N. Morton Street, Suite 120, Bloomington, IN 47404.** Payment will be remitted to Contractor within forty-five (45) days of receipt of invoice. Additional services not set forth in Article 1, or changes in the Services must be authorized in writing by the Department or its designated project coordinator prior to such work being performed, or expenses incurred. The Department shall not make payment for any unauthorized work or expenses.

Article 5. Appropriation of Funds Notwithstanding any other provision of this Agreement, if funds for the continued fulfillment of this Agreement by the Department are at any time not forthcoming or are insufficient, through failure of any entity, including the Department itself, to appropriate funds or otherwise, then the Department shall have the right to terminate this Agreement without penalty.

Article 6. Schedule Contractor shall perform the Services according to the following schedule: Services will be on as needed basis upon request of the Department. The time limits established by this schedule shall not be exceeded, except for reasonable cause as mutually agreed to by all parties.

Article 7. Termination In the event of a party's substantial failure to perform in accordance with the terms of this Agreement, the other party shall have the right to terminate the Agreement upon written notice. The nonperforming party shall have fourteen (14) calendar days from the receipt of the termination notice to cure or to submit a plan for cure acceptable to the other party. Additionally, the Department may terminate or suspend performance of this Agreement at the Department's prerogative at any time upon written notice to Contractor. Contractor shall terminate or suspend performance of the Services on a schedule acceptable to the Department and the Department shall pay the Contractor for all the Services performed up to the date that written notice is received, plus reasonable termination or suspension expenses. Upon restart, an equitable adjustment shall be made to Contractor's compensation and the schedule of services. Upon termination or suspension of this Agreement, all finished or unfinished reports, drawings, collections of data and other documents generated by Contractor in connection with this Agreement shall become the property of the Department, as set forth in Article 9 herein.

Article 8. Identity of the Contractor Contractor acknowledges that one of the primary reasons for its selection by the Department to perform the Services is the qualifications and experience of Contractor. Contractor thus agrees that the Services to be performed pursuant to this Agreement shall be performed by Contractor. Contractor shall not subcontract any part of the Services without the prior written permission of the Department. The Department reserves the right to reject any of the Contractor's personnel or proposed outside professional sub-Contractors, and the Department reserves the right to request that acceptable replacement personnel be assigned to the project.

Article 9. Ownership of Documents and Intellectual Property All documents, drawings and specifications, including digital format files, prepared by Contractor and furnished to the Department as part of the Services shall become the property of the Department. Contractor shall retain its ownership rights in its design, drawing details, specifications, databases, computer software and other proprietary property. Intellectual property developed, utilized or modified in the performance of the Services shall remain the property of Contractor.

Article 10. Independent Contractor Status During the entire term of this Agreement, Contractor shall be an independent contractor, and in no event shall any of its personnel, agents or sub-contractors be construed to be, or represent themselves to be, employees of the Department. Contractor shall be solely responsible for the payment and reporting of all employee and employer taxes, including social security, unemployment, and any other federal, state, or local taxes required to be withheld from employees or payable on behalf of employees.

Article 11. Indemnification Contractor shall defend, indemnify, and hold harmless the City of Bloomington, the Department, and the officers, agents and employees of the City and the Department from any and all claims, demands, damages, costs, expenses or other liability arising out of the Agreement or occasioned by the reckless or negligent performance of any provision thereof, including, but not limited to, any reckless or negligent act or failure to act or any misconduct on the part of the Contractor or its agents or employees, or any independent contractors directly responsible to it (collectively "Claims").

Article 12. Insurance During the performance of any and all Services under this Agreement, Contractor shall maintain the following insurance in full force and effect: a) General Liability Insurance, with a minimum combined single limit of \$1,000,000 for each occurrence and \$2,000,000 in the aggregate; b) Automobile Liability Insurance, with a minimum combined single limit of \$1,000,000 for each person and \$1,000,000 for each accident; c) Workers' Compensation Insurance in accordance with the statutory requirements of Title 22 of the Indiana Code; and d) Professional Liability Insurance ("Errors and Omissions Insurance") with a minimum limit of \$1,000,000 annual aggregate. All insurance policies shall

be issued by an insurance company authorized to issue such insurance in the State of Indiana. The City of Bloomington, the Department, and the officers, employees and agents of each shall be named as insureds under the General Liability, Automobile, and Worker's Compensation policies, and such policies shall stipulate that the insurance will operate as primary insurance and that no other insurance of the City's will be called upon to contribute to a loss hereunder. Contractor shall provide evidence of each insurance policy to the Department prior to the commencement of work under this Agreement.

Article 13. Conflict of Interest Contractor declares that it has no present interest, nor shall it acquire any interest, direct or indirect, which would conflict with the performance of Services under this Agreement. Contractor agrees that no person having any such interest shall be employed in the performance of this Agreement.

Article 14. Waiver No failure of either party to enforce a term of this Agreement against the other shall be construed as a waiver of that term, nor shall it in any way affect the party's right to enforce that term. No waiver by any party of any term of this Agreement shall be considered to be a waiver of any other term or breach thereof.

Article 15. Severability The invalidity, illegality or unenforceability of any provision of this Agreement or the occurrence of any event rendering any portion or provision of this Agreement void shall in no way affect the validity or enforceability of any other portion or provision of this Agreement. Any void provision shall be deemed severed from this Agreement, and the balance of the Agreement shall be construed and enforced as if it did not contain the particular provision to be held void. The parties further agree to amend this Agreement to replace any stricken provision with a valid provision that comes as close as possible to the intent of the stricken provision. The provisions of this Article shall not prevent this entire Agreement from being void should a provision which is of the essence of this Agreement be determined void.

Article 16. Assignment Neither the Department nor the Contractor shall assign any rights or duties under this Agreement without the prior written consent of the other party. Unless otherwise stated in the written consent to an assignment, no assignment will release or discharge the assignor from any obligation under this Agreement.

Article 17. Third Party Rights Nothing in this Agreement shall be construed to give any rights or benefits to anyone other than the parties.

Article 18. Governing Law and Venue This Agreement shall be governed by the laws of the State of Indiana. Venue of any disputes arising under this Agreement shall be in the Monroe Circuit Court, Monroe County, Indiana.

Article 19. Non-Discrimination Contractor shall comply with City of Bloomington Ordinance 2.21.020 and all other federal, state and local laws and regulations governing non-discrimination in all regards, including, but not limited to, employment. Contractor understands that the City of Bloomington prohibits its employees from engaging in harassment or discrimination of any kind, including harassing or discriminating against independent contractors doing work for the City. If the Contractor believes that a City employee engaged in such conduct towards Contractor and/or any of its employees, Contractor or its employees may file a complaint with the City department head in charge of the Contractor's work and/or with the City human resources department or the Bloomington Human Rights Commission. The City takes all complaints of harassment and discrimination seriously and will take appropriate disciplinary action if it finds that any City employee engaged in such prohibited conduct.

Article 20. Compliance with Laws In performing the Services under this Agreement, Contractor shall comply with any and all applicable federal, state and local statutes, ordinances, plans and regulations, including any and all regulations for protection of the environment. Where such statutes, ordinances, plans or regulations of any public authority having any jurisdiction over the project are in conflict, Contractor shall proceed using its best judgment only after attempting to resolve any such conflict between such governmental agencies, and shall notify the Department in a timely manner of the conflict, attempts of resolution, and planned course of action.

Article 21. E-Verify Contractor is required to enroll in and verify the work eligibility status of all newly-hired employees through the E-Verify program. (This is not required if the E-Verify program no longer exists). Contractor shall sign an affidavit, attached as Exhibit A, affirming that Contractor does not knowingly employ an unauthorized alien. Contractor shall require any subcontractors performing work under this contract to certify to the Contractor that, at the time of certification, the subcontractor does not knowingly employ or contract with an unauthorized alien and the subcontractor has enrolled in and is participating in the E-Verify program. Contractor shall maintain on file all subcontractors' certifications throughout the term of the contract with the City.

Article 22. Notices Any notice required by this Agreement shall be made in writing to the individuals/addresses specified below:

Department: City of Bloomington Public Works, Attn: J.D. Boruff, 401 N. Morton, Suite 120, Bloomington, Indiana 47404.

Contractor: Harrell-Fish, Inc., P.O. Box 1998., Bloomington Indiana 47402.

Nothing contained in this Article shall be construed to restrict the transmission of routine communications between representatives of the Department and Contractor.

Article 23. Integration and Modification This Agreement, including all Exhibits incorporated by reference, represents the entire and integrated agreement between the Department and the Contractor. It supersedes all prior and contemporaneous communications, representations and agreements, whether oral or written, relating to the subject matter of this Agreement. This Agreement may be modified only by a written amendment signed by both parties hereto.

Article 24. Non-Collusion Contractor is required to certify that it has not, nor has any other member, representative, or agent of Contractor, entered into any combination, collusion, or agreement with any person relative to the price to be offered by any person nor prevented any person from making an offer nor induced anyone to refrain from making an offer and that this offer is made without reference to any other offer. Contractor shall sign an affidavit, attached hereto as Exhibit B, affirming that Contractor has not engaged in any collusive conduct. Exhibit B is attached hereto and incorporated by reference as though fully set forth.

Article 25: Renewal This Agreement may be renewed for three additional one-year terms so long as none of the terms and conditions herein are modified in any way. Renewal shall only occur upon advanced written notice by the City to the Contractor that the City wishes to renew the Agreement at least thirty (30) days, but not more than sixty (60) days, prior to the end of the current term.

CITY OF BLOOMINGTON

Harrell-Fish, Inc.

John Hamilton, Mayor

Steve Dawson, President

CITY OF BLOOMINGTON PUBLIC WORKS

Adam Wason, Director

Dana Henke, President, Board of Public Works

EXHIBIT B

STATE OF INDIANA)
) SS:
COUNTY OF _____)

NON-COLLUSION AFFIDAVIT

The undersigned offeror or agent, being duly sworn on oath, says that he has not, nor has any other member, representative, or agent of the firm, company, corporation or partnership represented by him, entered into any combination, collusion or agreement with any person relative to the price to be offered by any person nor to prevent any person from making an offer nor to induce anyone to refrain from making an offer and that this offer is made without reference to any other offer.

OATH AND AFFIRMATION

I affirm under the penalties of perjury that the foregoing facts and information are true and correct to the best of my knowledge and belief.

Dated this _____ day of _____, 20____.

Harrell-Fish, Inc.

By: _____

STATE OF INDIANA)
) SS:
COUNTY OF _____)

Before me, a Notary Public in and for said County and State, personally appeared _____ and acknowledged the execution of the foregoing this _____ day of _____, 20____.

Notary Public's Signature
My Commission Expires: _____
Commission Number: _____
County of Residence: _____

Printed Name of Notary Public

**SUPPLEMENT #1 TO 2022 SERVICE AGREEMENT FOR
HFI FOR PLUMBING SERVICES**

This Supplement #1 amends the original 2022 Service Agreement with HFI for plumbing repair and inspection services for all facilities maintained by the Department, which was entered into on November 9, 2021, and which is attached hereto and incorporated herein by reference.

1. **Article 4. Compensation** provides that the not to exceed cost of this Service Agreement could be amended to add additional services not set forth in the original agreement. The original Not to Exceed cost was \$60,000. The Supplement #1 would increase the total compensation allowed under this Agreement by \$10,000, to a new Not to Exceed cost of to \$70,000, after the Department determined it had underestimated the amount of work they would have for HFI to perform
2. In all other aspects, the Agreement shall remain in effect as originally written.

IN WITNESS WHEREOF, the parties have caused this Amendment to be executed on the day and year last written below.

OWNER

Kyla Cox Deckard
President, Board of Public Works

Jennifer Lloyd
Vice President, Board of Public Works

Elizabeth Karon
Secretary, Board of Public Works

Date: _____

John Hamilton
Mayor

Date: _____

CONTRACTOR

Steve Dawson, President of HFI

Date: _____

REGISTER OF PAYROLL CLAIMS
Board: Board of Public Works Claim Register

Date:	Type of Claim	FUND	Description	Bank Transfer	Amount
10/7/2022	Payroll				495,479.95
					<u>495,479.95</u>

ALLOWANCE OF CLAIMS

We have examined the claims listed on the foregoing register of claims, consisting of 1
claim, and except for the claims not allowed as shown on the register, such claims are hereby allowed in the
total amount of \$ 495,479.95

Dated this 11th day of October year of 2022.

Kyla Cox Deckard, President Jennifer Lloyd, Vice President Elizabeth Karon, Secretary

I hereby certify that each of the above listed voucher(s) or bill(s) is (are) true and correct and I have audited same in accordance with IC 5-11-10-1.6.

Fiscal Officer _____



Board of Public Works Staff Report

Project/Event: Resolution to Uphold Order to Remove or Repair
Petitioner/Representative: HAND
Staff Representative: Michael Arnold
Date: October 11, 2022

Report:	August 24, 2022	A drive by to evaluate the site
	September 01, 2022	Sent Order to Remove
	September 20, 2022	Email string with Owner's Representative
	September 21, 2022	Sent Amended Order to Remove or Repair
	October 11, 2022	BPW Meeting

On August 24, 2022, a drive by inspection of this property occurred and HAND determined that the property was and is in a state of disrepair from renovation that stalled and remained idle and exposed to the elements all while the entire structure remained open to unauthorized entry. On September 2, 2022, HAND issued an Order to Remove. Owner's Representative cooperated with HAND and HAND agreed to give the Owner time to repair the structure instead of removing. On September 21, 2022, HAND issued an amended order that permits either removal or repair and to also maintain the property in a secure status in the event the repair project does not move forward. HAND asks the Board to uphold the Order of September 21, 2022.





**City of Bloomington
Housing and Neighborhood Development**

September 21, 2022

1635 N College LLC
3802 E 3rd St
Bloomington IN 47401

**UNSAFE BUILDING
ORDER TO REMOVE OR REPAIR**

RE: Structure(s) located at 1635 N College Ave
Legal description of relevant property: 013-27550-00 Building on Land Leased from;
Anderson, Rhea (PT SW 28-9-1W)

You are the recorded owner of the aforementioned property ("Property"). A recent inspection determined the Property to contain an unsafe structure(s) and revealed violations of Bloomington Municipal Code ("B.M.C.") Chapter 17.16 and Indiana Code ("I.C.") Chapter 36-7-9. Pursuant to B.M.C. Chapter 17.16 and I.C. § 36-7-9-5(a)(5), you are hereby **ORDERED** to **REMOVE** or **REPAIR THE STRUCTURE(S)** at the above-referenced property within **60** days, to wit: by 12 midnight local time on **November 21, 2022**. This Order expires on September 21, 2024.

The following actions must be taken to comply with this Order:

1. **Contact Monroe County Building Department regarding requirements for a permit to Remove or a permit to Repair**
2. **Seal the structure or surround the structure with fencing (minimum 6 feet in height) to prevent unauthorized access. This shall be completed within 10 days of the receipt of this Order**
3. **A timeline for work to be completed shall be submitted to HAND within 10 days of receipt of this Order**
4. **Remove or Repair the structure.**
5. **Removal requires backfill of any crawl space or basement with approved materials**
6. **Contact HAND upon completion of the work**

The structure referenced above is being declared unsafe in accordance with B.M.C. Chapter 17.16 and I.C. § 36-7-9-4(a) and this **ORDER TO REMOVE or REPAIR** is being issued as a result of inspection(s) conducted by HAND on August 24, 2022 and email correspondence on September 20, 2022. The inspection(s) revealed that the property is:

401 N. Morton
PO Box 100
Bloomington, IN 47402

City Hall

www.bloomington.in.gov/hand

Rental Inspections: (812) 349-3420
Housing Division: (812) 349-3401
Fax: (812) 349-3582

- In an impaired structural condition that makes it unsafe to a person or property;
- A fire hazard;
- A hazard to the public health;
- A public nuisance;
- Dangerous to a person or property because of a violation of the below listed statute or ordinance concerning building condition or maintenance:
; and/or
- Vacant and not maintained in a manner that would allow human habitation, occupancy, or use under the requirements of the below listed statute or ordinance:

The law requires a hearing be held before this Order can go into effect. To that end, a hearing will be conducted by the City of Bloomington's ("City") Board of Public Works ("Board") at **5:30 p.m. local time on October 11, 2022**. The hearing will take place in the City's Common Council Chambers, located at 401 North Morton Street, Bloomington, Indiana. The meeting may be online or may be a hybrid meeting. Contact Public Works for more information at 812-349-3411. You or your legal counsel may present evidence, cross-examine witnesses, and present arguments at this hearing.

Failure to comply with this Order by the deadline(s) imposed may result in the City issuing citations for violations of the B.M.C., civil penalties being assessed against you, a civil suit being filed against you, the City making the necessary repairs (either by itself or via the use of an independent third-party contractor) and placing a lien on the Property to recover costs associated with this action, and/or demolition of the Property.

You must notify the City's HAND Department within five (5) days if you transfer title, or if another person or entity agrees to take a substantial interest in the Property. This notification shall include the full name, address and telephone number of the person or entity taking title of or substantial interest in the Property. The legal instrument used in the transfer must also be supplied to the HAND Department. Failure to comply with this notification requirement may render you liable to the City if a judgment is entered for the failure of the City to provide notice to persons holding an interest in the Property.

If you have questions regarding this Order, please feel free to contact Neighborhood Compliance Officer Mike Arnold during normal business hours at the address, telephone number, and/or email herein provided:

Michael Arnold
Neighborhood Compliance Officer
Housing & Neighborhood Development Department (HAND)
401 N. Morton Street/P.O. Box 100
Bloomington, Indiana 47402
(812) 349-3401
arnoldm@bloomington.in.gov

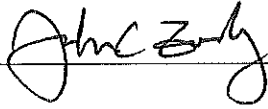

John Zody, Director
City of Bloomington
Housing & Neighborhood Development (HAND)
401 N. Morton Street/P.O. Box 100
Bloomington, Indiana 47402

9/21/22

Date

1635 N College Ave
August 24, 2022

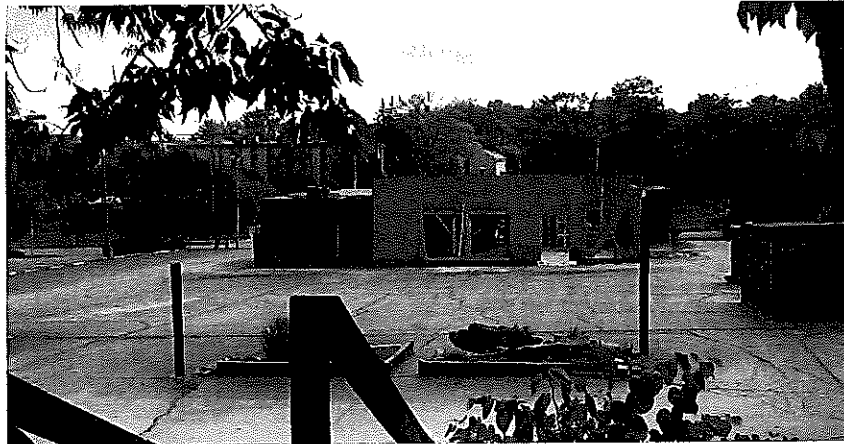



FOR
Deve
012-330-2



**BOARD OF PUBLIC WORKS
RESOLUTION 2022-80
Unsafe Order for 1635 N. College Avenue, Bloomington, Indiana**

WHEREAS, on September 21, 2022, the City of Bloomington Housing and Neighborhood Development (“HAND”) issued an **Order To Remove or Repair** on real estate located at 1635 N. College Avenue, Bloomington, Indiana (the "Property") because the structure is unsafe as defined by both Indiana Code 36-7-9 and Chapter 17.16 of the Bloomington Municipal Code; and

WHEREAS, HAND issued an Order to the owner of record for the Property, and those individuals or corporations who are believed to have a substantial interest in the Property, in accordance with the rules and procedures outlined in Indiana Code 36-7-9 *et seq.* and Chapter 17.16 of the Bloomington Municipal Code; and

WHEREAS, the Board of Public Works heard testimony and reviewed evidence on this Order at its Regular Meeting of Tuesday, October 11, 2022.

NOW, THEREFORE, BE IT RESOLVED THAT THE BOARD OF PUBLIC WORKS HEREBY:

- Affirms the Order issued by HAND on September 21, 2022.
- Rescinds the Order issued by HAND on September 21, 2022.
- Modifies the Order issued by HAND on September 21, 2022. This modification is less stringent than HAND's original Order and now requires the property owner to take the following actions:

So Ordered this 11th day of October, 2022.

By: _____
Kyla Cox Deckard, President of the Board

STATE OF INDIANA)
) SS:
COUNTY OF MONROE)

Before me, a Notary Public in and for said County and State, personally appeared _____, of the City of Bloomington Board of Public Works, who acknowledged the execution of the foregoing Resolution as a voluntary act and deed.

Signature of Notary Public

Date Commission expires

Name of Notary Public

County of Residence

Commission Number: _____



Board of Public Works Staff Report

Project/Event:	Contract with Toole Design Group, LLC for a Corridor Study of College Avenue and Walnut Street
Petitioner/Representative:	--
Staff Representative:	Beth Rosenbarger, Assistant Director, Planning and Transportation Department
Meeting Date:	10/11/2022

Process to select consultant team: The City of Bloomington issued a Request for Information (RFI) on February 15, 2022, and the RFI closed on March 28, 2022. The City received seven submissions from interested consultant teams. An internal team reviewed the submissions based on the criteria included in the RFI. An internal and external team interviewed two of the consultant teams. Toole Design Group, LLC was selected through this process to lead the Corridor Study. The contract amount is \$170,000. The amount for this project was made available to all applicants in the RFI.

The Corridor Study: Through this contract, Toole Design Group will develop a Corridor Study and Conceptual Design for College Avenue and Walnut Street from the 45/46 Bypass to Allen Street (The Study). The Study, which will include a recommended conceptual design, will reflect the vision, goals, policies, and programs of the City's latest Comprehensive Plan and Transportation Plan. The need for a corridor study was identified in the 2019 Transportation Plan. The Comprehensive Plan and the Transportation Plan are available online: <https://bloomington.in.gov/planning/documents>.

Goals of the Study: The Study aims to analyze the existing conditions and create a conceptual redesign of College Avenue and Walnut Street. The analysis and conceptual design must align with the goals of the Comprehensive Plan, as well as the detailed objectives outlined in the [Transportation Plan](#) (see page #61, *Improve Multimodal Travel along N-S and E-W Corridors*).

As described in the Transportation Plan, the following is a list of some priorities for The Study:

- 1) Improve pedestrian access, safety, and comfort along and across the length of the corridors;
- 2) Improve bicyclists access with safe, protected bicycle paths throughout the length of the corridors;
- 3) Improve bus transportation by providing safe and efficient ways to travel along the corridors; this shall include consideration of bus-only lanes, bus rapid transit, bus shelter improvements, and other recommended considerations;

- 4) Anticipate and make recommendations regarding other forms of transportation that further the goals of the Comprehensive Plan;
- 5) Facilitate safe and efficient automobile traffic to the maximum extent possible in light of the aforementioned goals; and
- 6) Enhance the vitality of Downtown Bloomington's businesses and institutions.

City of Bloomington Contract and Purchase Justification Form

Vendor: Toole Design Group, LLC

Contract Amount: \$170,000

This form should be completed and attached to the contract documents and forwarded to the Legal Department Attorney assigned to your Department. Contracts will not be approved by the Controller if a completed form is not included with the contract documents.

PURCHASE INFORMATION

1. Check the box beside the procurement method used to initiate this procurement: (Attach a quote or bid tabulation if applicable)

<input type="checkbox"/> Request for Quote (RFQ)	<input type="checkbox"/> Request for Proposal (RFP)	<input type="checkbox"/> Sole Source	<input type="checkbox"/> Not Applicable (NA)
<input type="checkbox"/> Invitation to Bid (ITB)	<input checked="" type="checkbox"/> Request for Qualifications (RFQu)	<input type="checkbox"/> Emergency Purchase	

2. List the results of procurement process. Give further explanation where requested. Yes No

# of Submittals: 7	Yes	No	
Met city requirements?	<input checked="" type="checkbox"/>	<input type="checkbox"/>	Was the lowest cost selected? (If no, please state below why it was not.) <input checked="" type="checkbox"/> Yes <input type="checkbox"/> No We issued a Request for Information. The RFI defined the budget amount for the project, and all submittals were required to meet the budget.
Met item or need requirements?	<input checked="" type="checkbox"/>	<input type="checkbox"/>	
Was an evaluation team used?	<input checked="" type="checkbox"/>	<input type="checkbox"/>	
Was scoring grid used?	<input checked="" type="checkbox"/>	<input type="checkbox"/>	
Were vendor presentations requested?	<input checked="" type="checkbox"/>	<input type="checkbox"/>	

3. State why this vendor was selected to receive the award and contract:

The vendor was selected to receive the award based on a review of their qualifications, their proposed project approach, their team member qualifications, and their experience with similar projects. From the 7 submittals received and evaluated, team members were confident in Toole Design Group's ability to complete this project successfully.

Beth Rosenbarger

Assistant Director

Planning and Transportation

Print/Type Name

Print/Type Title

Department

GENERAL INFORMATION AND SUMMARY

Organization Issuing Request for Information:

City of Bloomington
Planning and Transportation Department
401 N. Morton St, Suite 130
Bloomington, Indiana 47404

Contact:

Beth Rosenbarger, AICP
Planning Services Manager
rosenbab@bloomington.in.gov

Summary of Request:

The City of Bloomington (the City) is issuing this Request for Information (RFI) to aid in the selection of a consultant team to develop a Corridor Study and Conceptual Design for College Avenue and Walnut Street from the 45/46 Bypass to Allen Street (The Study). The Study will reflect the vision, goals, policies, and programs of the City's latest Comprehensive Plan and Transportation Plan. Interested parties must provide submittals as outlined in this document electronically by Monday, March 28, 2022, at 5:00 PM local time (EST).

Communications and Project Management:

The project will be managed by the City's Planning and Transportation Department with input from other City departments. All communications from interested parties to the City during the submission process shall be made to Beth Rosenbarger at rosenbab@bloomington.in.gov.

If necessary, interpretation of or changes to this RFI may be made by written addendum. A copy of each addendum will be posted on the City's Transportation Plan website at <https://bloomington.in.gov/transportation/plan> no later than March 18, 2022. Interested parties are responsible for checking the City's website for addenda, though the City may choose to contact all known interested parties with notification of posted addenda. The City will not be responsible for any other explanations or interpretations of this RFI. If significant changes to this RFI are required, then the City may postpone the final date for submission through an addendum.

Interested parties may notify the City via email of their intent to submit a response to this RFI but are not required to do so. Failure to notify the City of intent to submit a response may result in omission from future communications including possible notification of addenda.

Responses to the RFI must be submitted in pdf format no later than March 28, 2022, by 5:00PM EST. Responses which, in the judgment of the City, are in any way incomplete, inaccurate, or otherwise not in compliance with the requirements described in this RFI may be rejected. The City reserves the right to contact consultants to ask questions, request additional information, or request an interview.

Any costs incurred while responding to this RFI in anticipation of receiving a contract award shall be the responsibility of the entity submitting the response. The City shall not reimburse any respondent for any such expenses.

RFI Process Schedule:

February 15, 2022	RFI Advertisement
March 14, 2022	Deadline for questions/clarifications
March 18, 2022	Last Day for Addenda Posted by the City
March 28, 2022 (5:00pm EST)	RFI Response Deadline
April 18, 2022*	Respondents Notified of Results
May 16, 2022*	Issue Notice to Proceed (NTP)

**Dates indicated are tentative and subject to change as needed*

CORRIDOR STUDY DETAILS

The City is seeking a consultant to develop a Corridor Study and Conceptual Design for College Avenue and Walnut Street from the 45/46 Bypass to Allen Street (The Study). The Study, which will include a recommended conceptual design, will reflect the vision, goals, policies, and programs of the City’s latest Comprehensive Plan and Transportation Plan. The need for a corridor study was identified in the 2019 Transportation Plan. The Comprehensive Plan and the Transportation Plan are available online: <https://bloomington.in.gov/planning/documents>.

Process Goals:

The process for developing The Study is critical to the success of The Study. The City envisions a process with two phases; however, respondents are welcome to propose a different process that includes public engagement and creates a successful conceptual design.

- Phase One: Corridor Analysis; consultants collect, analyze, and present data. Through public engagement, consultants develop consensus around goals for the conceptual design.
 - The purpose of this phase is to develop consensus around the goals of what a conceptual redesign should accomplish in our community. While goals for the corridor have been identified in the adopted Transportation Plan, other goals for the corridor can be developed and incorporated based on community engagement. This phase focuses on analyzing what is working, what needs improvement, and why.
 - Data collection will include quantitative and qualitative data.
 - The City can provide some traffic count data, limited bicycle count data, and crash data. It is expected that other quantitative data will be needed to analyze the many uses of the corridor.
 - Consultants are expected to collect qualitative data. This data may include observation data; interviews with business owners, residents, and more; surveys and public input; and other relevant experiential data.
 - Consultants may propose other tools and data collection techniques to better understand traffic volumes, origins/destinations, active transportation users, bus transit, and more.
 - Data and corridor analysis:

- It is expected that the quantitative analysis will include a traffic simulation. The City has an existing Synchro model and some pre-pandemic traffic counts that will be provided to the consultants to assist in the development of the simulation.
 - The analysis and The Study are primarily focused on street design and infrastructure. The consultants should assume no zoning changes; however, consultants can identify infrastructure changes needed to achieve the community’s current land use goals.
 - Public presentations: This may involve multiple public meetings and engagement opportunities. It must include a format to share the corridor analysis publicly at the end of the phase before moving on to phase two.
- Phase Two: Create a feasible conceptual design using the adopted goals for the corridor and goals added through public engagement in phase one.
 - The purpose of this phase is to use the analysis and goals established in phase one in order to collaboratively develop a corridor conceptual design. This may be a charrette approach or other public engagement-based model.
 - This may include multiple design alternatives.
 - The proposed conceptual design should be analyzed using the tools from phase one, such as the goals, the traffic simulation, and more.
 - Analysis of conceptual design options may include analysis of the potential for development, redevelopment, and investment that may be spurred by the design alternatives.
 - This phase must involve robust, direct public engagement with many stakeholder groups as well as opportunities for all members of the public to share input.
 - The conceptual design is detailed to the level of providing the cross-sections for each block and/or phase of the corridors. The conceptual design is a design that will be used to develop a future construction plan set.
 - The development of the conceptual design using a public engagement process must include the use of creative visuals. This could include virtual, augmented reality, infographics, cross-sections, and other tools. Please propose what visual tools you recommend to help residents envision the conceptual plan.
 - This phase may include presenting to several city boards, commissions, or public bodies.

Process Timeline:

The City envisions a project timeline of approximately one year. The City would like respondents to propose a project timeline that emphasizes public engagement and includes time for feedback loops at multiple points throughout the project.

Process Expectations:

Robust public engagement throughout The Study’s development is expected. Public engagement should include virtual and in-person options. Thorough data collection and analysis is expected. An understanding of the community’s values and goals, as expressed in the Comprehensive Plan, is expected and must inform The Study.

Goals of the Study:

The Study aims to analyze the existing conditions and create a conceptual redesign of College Avenue and Walnut Street. The analysis and conceptual design must align with the goals of the Comprehensive Plan, as well as the detailed objectives outlined in the [Transportation Plan](#) (see page #61, *Improve Multimodal Travel along N-S and E-W Corridors*).

As described in the Transportation Plan, the following is a list of some priorities for The Study:

- 1) Improve pedestrian access, safety, and comfort along and across the length of the corridors;
- 2) Improve bicyclists access with safe, protected bicycle paths throughout the length of the corridors;
- 3) Improve bus transportation by providing safe and efficient ways to travel along the corridors; this shall include consideration of bus-only lanes, bus rapid transit, bus shelter improvements, and other recommended considerations;
- 4) Anticipate and make recommendations regarding other forms of transportation that further the goals of the Comprehensive Plan;
- 5) Facilitate safe and efficient automobile traffic to the maximum extent possible in light of the aforementioned goals; and
- 6) Enhance the vitality of Downtown Bloomington's businesses and institutions.

As noted in the Process section, the City is open to incorporating other goals or priorities that align with the community's adopted goals based on public feedback. The analysis and The Study are primarily focused on street design and infrastructure. The consultants should assume no zoning changes; however, consultants should identify infrastructure changes needed to achieve the community's current land use goals.

Deliverables:

- A feasible, conceptual design for College Avenue and Walnut Street from the 45/46 bypass to Allen Street, including cross-sections and plan view.
- An implementation strategy that includes short-term and long-term concepts with cost estimates for design and construction. The short-term concept will propose changes that can be quickly and easily installed. A mid-term concept is optional.
- All elements combined and provided as a final document, which includes the conceptual design, summary of public engagement, traffic analysis, other analysis elements, etc.
- Multiple public presentations and public meetings, which may include presentations to city boards, commissions, and official bodies, and may include a final presentation.

The City encourages submissions from Minority-Owned Business Enterprises (MBE), Women's Business Enterprises (WBE), Small Business Enterprises (SBE), local firms, and diverse teams. This RFI is open to any individual/firm wishing to submit a response.

Funding Source and Associated Requirements:

This project is funded locally. Responses to this RFI shall be prepared with an assumed maximum project budget of \$170,000. Tasks that cannot be accomplished within that budget shall be explicitly labeled as beyond the project's budget and optional services.

September 20, 2022

Beth Rosenbarger, AICP
Assistant Director, Planning and Transportation Department
City of Bloomington
401 N. Morton Street, Suite 130
Bloomington, IN 47402
Ph: 812.349.3473
Email: rosenbab@bloomington.in.gov

RE: College and Walnut Corridor Study - Scope and Fee Proposal DRAFT

Dear Beth:

Toole Design is very pleased to submit the attached scope and fee estimate to conduct the College Avenue and Walnut Street Corridor Study for the City of Bloomington, IN. The scope and fee are based on our understanding of the City's desire to produce a community-supported conceptual plan for the two streets in downtown Bloomington, and the feedback we received during the selection process.

The Toole Design team looks forward to working with you and the City in the coming months.

Sincerely,

Drew Parker | Senior Planner

TOOLE DESIGN

dparker@tooledesign.com | 720.204.7061 x559

Scope of Work

Task 1: Project Management

A successful project begins with clear project decision-making structure that is designed to meet the overall goal of the project. In an effort to obtain broad approval of the outcome of the study, the decision-making structure is divided in two levels: Project Management Team and Steering Committee. The composition and anticipated role of the two groups are as follows:

Project Management Team (PMT): The PMT will comprise of key City staff who will make day-to-day decisions on the project. It may be composed of City Project Manager, and key department representatives. They will receive on-going updates and guide the overall project process. Toole Design will attend monthly virtual meetings with the PMT to provide regular updates and obtain project direction.

Steering Committee (SC): The members of the SC will be determined in discussions with City staff and may include business owners, representatives of chamber of commerce, advocacy groups, historically under-represented members and other community leaders. The SC will make key decisions on the project, including deciding on draft concepts to present to the public, and approve the final recommendation of the study. Toole Design will prepare for and attend four (4) SC meetings during the course of the project.

At the start of the project, Toole Design will convene and facilitate an internal virtual PMT kickoff meeting with City of Bloomington (City) staff to review and confirm project vision, goals, objectives, schedule, and budget. During this meeting, we will also clarify the City's project management expectations for the project. Additionally, we anticipate discussing available background documents and data that will be important to complete the existing conditions phase (Task 2). Following the kickoff meeting, Toole Design will revise and finalize the project Work Plan (including a detailed schedule) and will create a Public Involvement Plan.

Task 1.1: Public involvement plan

The public involvement plan (PIP) plan will document the types of public outreach that will be conducted during the course of this study. Where appropriate, Toole Design team will collect basic demographic, and socio-economic information of the participants to understand the level of engagement of various community groups. This information will be utilized to modify the PIP as necessary to ensure wide participation from community members. Special attention will be given to historically under-represented group's participation and targeted outreach will be conducted to encourage their involvement in the study. The PIP will include following tasks:

Project Website Support: Toole Design team will provide draft language to be included in the project website, which will be hosted by City of Bloomington. We will also provide graphics, maps, and documents to be uploaded on the website. Draft documents on the website will be made available for public comments for any duration as directed by the PMT. Some of the documents that will be uploaded are revised vision and goal statements, draft conceptual plan, final recommended concept plan, etc.

Project Survey and Flyers: Toole Design team will prepare a survey questionnaire to obtain feedback from community members, especially for those who may not be able to attend in-person events. The survey will be uploaded on the project website and information disseminated via social media campaign, The Toole Design team will prepare draft language and graphics for the social media campaign including a sample schedule for when to make posts. The Toole Design team will also create a postcard advertising the project to be printed and mailed by the City.

Business Owner Meetings: During the discover and design charrette, Toole Design team will participate in one-on-one and group meetings with business owners along the corridor to obtain their opinions on project goals as well as identify their key issues on the corridor.

Advocacy and Under-represented Group Meetings: During the discover and design charrette, Toole Design team will participate in one-on-one and group meeting with advocacy and historically under-represented groups to obtain their opinions on project goals and identify their key issues along the corridor.

City Department Meetings: During the discovery and design charrette, Toole Design team will meet with various city departments like Bloomington Transit, Fire Department, Police Department, Maintenance and Operation, etc., to obtain their opinions on project goals and identify their key issues along the corridor.

Public Meetings: Toole Design will prepare for and present at three public meetings. Two public meetings will be held during the discovery and design charette. Third public meeting will be held to present the draft conceptual plans and obtain feedback from the public.

Open House: During the discovery and design charrette, a total of eight (8) hours of public open house will be provided to allow any community member to speak with the project team, provide their opinions on project goals, and identify their key issues along the corridor.

TASK 1 DELIVERABLES:

- Project kickoff meeting and materials
- Project Work Plan
- Public Involvement Plan (including list of social media content and posting instructions)
- Draft and final project survey and website content
- Monthly PMT check-ins (12)
- Steering Committee meetings and materials (4)
- Monthly progress reports and invoices (12)

Task 2: Data Collection and Existing Conditions Analysis

Toole Design will evaluate existing conditions of College Avenue and Walnut Street, from the Indiana 45/46 Bypass to Allen Street, to serve as a baseline against which the conceptual designs can be compared. We will use all relevant existing conditions data from previous plans and studies to expedite the existing conditions task, where feasible.

Task 2.1: Background Research, Plan Review, and needs assessment

Toole Design will review the following relevant plans and studies: 2019 Bloomington Transportation Plan, 2021 Climate Action Plan, 2018 Comprehensive Plan, 2018 Downtown Area Parking Study, and other relevant plans.

As we draft the corridor study, we will articulate how the recommendations relate to and build upon prior planning efforts and principles and reference the documents accordingly. The Needs Assessment will document how the existing cross section and operations on College Avenue and Walnut Street fall short of the Vision Statement principle to *Provide a safe, efficient, accessible, and connected system of transportation that emphasizes public transit, walking, and biking to enhance options to reduce our overall dependence on the automobile* and how the recommendations of the corridor study will aim to achieve

that principle. The Needs Assessment will compile data from previously collected data and analyses including AADT, reported crash data, Bicycle Network Analysis (BNA), access to transit, and other data.

Task 2.2: Data Collection and Existing Conditions Multimodal analysis

We will analyze all available city data, including vehicular, pedestrian, and bicyclist volumes and previous traffic analyses of the project area. We will work with the city to identify where critical data are missing and needs to be collected. We anticipate collecting the following data sets to provide a clear picture of existing multimodal conditions of the corridor.

Motor Vehicle Operational Analysis:

Average Daily Traffic (ADT) Volume and Speed: We will collect 24-hour vehicular counts for 7 days possibly at 4th Street and Kirkwood Avenue on both College Avenue and Walnut Street or at a different location selected by City staff in consultation with Toole Design.

The ADT counts will be used as a baseline to compare to historic AADT data on the corridors. We will quantify the temporal profile of vehicle volumes along the corridors. The two ADT counts will also be used to calculate 85th-percentile and 50th-percentile speeds at these locations.

Turning Movement Count (TMC): We will utilize the ADT data to determine the two highest vehicular peak hours for the corridor. TMCs will be collected for those peak hours at two intersection locations to be determined with staff. The intersections of College Avenue and Walnut Street with the following streets will be included in the vehicular operational analysis (12 locations):

- 17th Street
- 10th Street
- 7th Street
- Kirkwood Avenue
- 3rd Street
- 2nd Street

The new TMCs will be used to compare to historic TMCs provided from the 2017 Citywide Signal Retiming. Using the ADT and TMC comparisons, a calibration factor will be calculated to apply to counts from the Citywide Signal Retiming to represent 2022 volumes. Synchro files provided by the city will be updated with the 2022 volumes and used to calculate existing vehicular operational analysis during the AM and PM peak hours, using the methodology outlined in the latest Highway Capacity Manual (HCM). Overall intersection LOS, delay, and v/c ratios will be mapped and detailed results including queue lengths will be provided in the form of Synchro reports.

Bicycle Level of Traffic Stress: Bicycle level of traffic stress (BLTS) is a measure that assigns one of four levels to road segments based on the perceived safety and comfort of a bicyclist next to moving traffic. The four BLTS levels, numbered 1 through 4 from best to worst, generally correspond with the “four types of transportation cyclists”. A BLTS 1 represents a street that is comfortable for young children to bike on, and low-stress bikeways are comprised of streets with BLTS 1 and 2.

The existing conditions BLTS will be computed by block using data that is already available or easily acquired (e.g., lane widths, lane configurations, vehicular speeds, and vehicle volumes), based on available GIS data, aerial, and Google Streetview imagery. The resulting scores will be mapped to show the changing conditions along a corridor. We will use BLTS tables that were developed by Peter Furth, June 2017 and were modified by Toole Design Group based on expert judgment.

Pedestrian Space: Conditions of sidewalk/pedestrian space will be quantified into categories based on the overall quality of the facilities. These categories will be based on features such as sidewalk width, buffer distance to traffic, frequency of obstructions, and traffic speed and volumes. Each block will be assigned a pedestrian space quality score and will be mapped. The pedestrian space analysis will also include the locations of existing street trees based on the most recent available aerial imagery.

Transit Analysis: Existing transit routes on College Avenue and Walnut Street will be mapped. Available transit data to be provided by the City will also be summarized. This may include ridership, boardings, alighting, accessibility information, and travel times.

Person Through-Put Analysis: Person capacity presents a holistic measurement of the person-carrying capacity of a street, rather than a focus on motor vehicle capacity. The person capacity of College Avenue and Walnut Street will be based on the maximum number of people the street can carry during peak hour depending upon the lanes available (i.e., general purpose travel lane, bike lane, transit-only lanes, sidewalks, etc.).

Parking Inventory: The length or number of on-street parking spaces available by block as well as any associated parking restrictions will be reported. This inventory will be based on data provided by the City, available GIS data, aerial, and Google Streetview imagery. On-street parking utilization will be noted if available in existing city datasets. The number of off-street parking spaces will also be mapped using the City's Parking Areas GIS dataset and the most current aerial imagery to fill in the gaps.

Driveways: The existing driveways will be mapped per block on both sides of the street using the City Edge of Pavement GIS dataset as a starting point and the most current aerial imagery to fill in the gaps.

Historic Crash Data: The reported crash data analysis conducted for the Transportation Plan (2010-2015) will be updated using the most recently available five years of data. Pedestrian-motor vehicle, bicycle-motor vehicle, and fatal and incapacitating injury crashes will be analyzed, and hot spots on College Avenue and Walnut Street will be mapped.

Safer Streets Priority Finder: The Safer Streets Priority Finder is a free and open-source resource, developed by Toole Design and the City of New Orleans on behalf of USDOT, that allows practitioners and advocates to analyze and understand the risk to vulnerable road users (bicyclists and pedestrians) on their local roadways. With just some minimal data prep required, this tool uses a Bayesian statistical framework to make a robust estimation of crash risk along the road network.

The tool takes into consideration areas where a disproportionate share of fatal and serious injury crashes have occurred and identifies areas that are at risk for future crashes. We will use the tool to identify these areas along College Avenue and Walnut Street to inform recommendations and help address access, safety, and mobility needs for people with disabilities and underserved communities. This analysis is contingent on availability of geocoded crash data.

Big Data Analysis: Toole Design will work with a Big Data provider to analyze origins and destinations for vehicle trips along College Avenue and Walnut Street. The Big Data analysis will also provide trip attributes including trip speed, travel time, and length as well as demographic data including inferred income, race, and education to highlight impacts on underserved communities and inform social equity goals.

The dataset can be used to inform the origin-destination analysis as well as mode shift potential based on existing trip lengths.

Loading Needs and Analysis: Existing formal (signed) and informal loading zones (in travel lanes) will be mapped based on city datasets and local knowledge.

Land Use Mapping: Existing land uses by property will be mapped to understand the context along each block of both streets. The land use mapping will note current or future anticipated developments and the location of vacant business properties.

TASK 2 DELIVERABLES:

- Draft and Final Existing Conditions Tech Memo
- Up to five (5) print and digital 24” x 36” exhibits with maps, graphs, and charts showing the results of the data analysis

Task 3: Discovery and Design Charrette

Task 3.1: Refining Corridor Vision

Toole Design will plan and conduct a hands-on 5-day discovery and design charrette to learn about stakeholder and community priorities, identify character zones, develop starter ideas and design themes, and conduct preliminary evaluation with the community. The project team will engage the city-identified stakeholder group, property owners, local businesses, residents, advocacy and historically under-represented groups, and city department staff. It will take place over approximately five days at a convenient location near the project area. The charrette will be divided into discovery days and design days. Table below shows the tentative schedule of the charrette.

Tentative Charrette Schedule

	Sunday	Monday	Tuesday	Wednesday	Thursday	Friday
Time	Arrival	Discovery Days		Design Days		Wrap Up Day
7 – 8 am	Team arrives (Time TBD based on available flights)		Stakeholder Interviews	Stakeholder Interviews	Open House / Develop success parameters	Additional stakeholder meetings, if needed
8 – 9 am						
9-10 am						
10 – 11 am		Preliminary site walk				Summarize notes
11 – 12 noon		Lunch with City	Open House / Confirm corridor vision	Open House / Develop starter ideas		
12 – 1 pm		Site Tour with City staff				Recap with City
1 – 2 pm						Team Leaves
2 – 3 pm					Prep for Public Meeting	
3 – 4 pm				Prep for Public Meeting		
4 – 5 pm						

5 – 6 pm					
6 – 7 pm		Meet Steering Committee	Discovery Public Meeting		Design Public Meeting

Discovery Days

The purpose of the discovery days is to refine the corridor vision and clarify what the overall community vision and goals, as outlined in the 2019 Transportation Plan, the 2021 Climate Action Plan, and the 2018 Comprehensive Plan, mean for this corridor. The discovery days will be focused on obtaining detail understanding of corridor operation, character, challenges, and opportunities. This will occur via site tour and series of meetings with stakeholders and community members.

In addition, the project team will work with the charrette participants to identify up to five parameters to define success for the project. These parameters will be used to evaluate the concept alternatives that will be developed for the corridors.

Design Days

The purpose of the design days is to develop character zones along the corridor, obtain relative priority of various right-of-way zones, develop initial modal themes, and create a multimodal transportation framework of the project area. All viable starter ideas that are developed with the community will be evaluated against the success parameters. The preliminary evaluation will be presented during the public meeting to obtain initial feedback from stakeholder and community members. The ideas that are most promising will form the basis for draft conceptual design alternatives in Task 4. The design days will be highly interactive and will allow the Toole Design team to work, in real time, with city staff and stakeholders.

TASK 3 DELIVERABLES:

- Discovery and Design charrette
- Two (2) public meetings
- Public Engagement Summary Memo

Task 4: Concept Development

Task 4.1: Initial Concept Alternatives

After the charrette, we will refine the character zones and starter ideas, into two initial concept alternatives for the corridor. At least one of the concept alternatives will include creating a bus rapid transit street which may include dedicated lanes, business access and transit (BAT) lanes, enhanced transit stops, and operational improvements to enhance transit travel times. The concept alternatives will be illustrated by one cross-section per character zone and a typical block plan view layout. Toole Design will conduct a planning level multimodal transportation analysis and evaluate success parameters to determine the impact of the concept alternatives. The planning level multimodal transportation analysis will show person-throughput calculations for the two concept alternatives and the percentage of space allocated to each travel mode as well as the changes in bicycle level of stress, transit operations, and pedestrian realm quality. One intersection and block will be selected per corridor to be evaluated per the

vehicular, bicycle, and pedestrian analysis methods used in the existing conditions analysis. We will develop planning level cost of the two concept alternatives. The concept alternatives, cost estimate and evaluation will be presented to the Steering Committee, via virtual meeting, and the community, via uploads to project website, for comments. We anticipate one round of comments on the initial concepts which will be incorporated in the preferred concept design.

Task 4.2: Preferred Conceptual Design & Assessment

A set of comments from the community and Steering Committee on the two concept alternatives will be used to develop one draft preferred conceptual design for the corridor. The draft preferred concept may incorporate various elements of the two concept alternatives. The draft preferred concept will be presented in typical cross-section and scaled CAD plan view of one block, showing two critical intersections (including lane configuration, modal ROW allocation, furnishing zones, etc.), for each character zone of the corridor. It will be presented to the Steering Committee, via virtual meeting, and the community, via uploads to project website, for comments. We anticipate one round of comments on the draft preferred comment, which will be incorporated to develop the final preferred conceptual design for the corridor. The evaluation of the preferred concept will include detail multimodal traffic analysis of critical study intersections, person through-put analysis and the impact on success parameters. The analysis will ensure that the selected options best match community needs and expectations, as well as project goals and objectives. In addition to alignment with the city's goals, the project team will identify any issues around implementation and execution, as well as potential impacts (e.g. right of way, drainage, utilities).

Planning-level cost estimates for the final preferred concept design will be developed to assist the city in future planning efforts.

TASK 4 DELIVERABLES:

- Character zones and their design parameters
- Two concept alternatives with typical cross-section and block
- Draft and final conceptual designs of preferred alternative
- Draft and Final Traffic Analysis Tech Memo
- Planning-level cost estimates
- Public meeting to present preferred alternative

Task 5: Final Documentation

The final study will be an aesthetically pleasing and graphic-heavy document that clearly communicates the project process and preferred conceptual design for the two corridors. The study will integrate the findings and deliverables of the subsequent tasks, telling a compelling story and outlining steps for implementing the desired vision. The document can be formatted to be print-ready, or it can be formatted to be primarily accessed and displayed digitally.

Task 5.1: Draft Corridor Study

The Toole Design team will combine previous deliverables and analyses into a concise Draft Corridor Study document. The Steering Committee will review the Draft Plan document, coordinate review by appropriate departments and other stakeholders, and provide one consolidated set of comments to Toole Design.

IMPLEMENTATION PLAN

The Toole Design team will provide an outline of next steps for moving towards implementation of the plan. A phased approach will likely be recommended that leverages existing and planned funded capital projects, and future development. Based on that information, we will provide what we believe are the “Top Five” items for implementation.

The corridor study will include following sections:

- Justification for the study
- Study process and public outreach summary
- Concept alternatives
- Final preferred concept
- Implementation plan

Task 5.2: Final Corridor Study

We will incorporate comments provided from the city staff and produce a final project plan that is ready for implementation. After all revisions have been made, the Final Study will be provided to the city for presentation to the city Council for final approval and adoption.

TASK 5 DELIVERABLES:

- Draft and Final Bloomington College and Walnut Corridor Study

Schedule

Below is a draft schedule to complete this scope of work. Toole Design will develop a detailed schedule with the City Project Manager once the project begins.

	Month	1				2				3				4				5				6				7				8				9				10				11				12			
	Week	1	2	3	4	1	2	3	4	1	2	3	4	1	2	3	4	1	2	3	4	1	2	3	4	1	2	3	4	1	2	3	4	1	2	3	4	1	2	3	4	1	2	3	4				
Task 1																																																	
NTP		M																																															
Kickoff Meeting			M																																														
Public Involvement Plan																																																	
Stakeholder Committee Meetings (4)							M					M				M					M																												
Task 2																																																	
Data Collection																																																	
Traffic Analysis																																																	
Task 3																																																	
Design Charrette								M																																									
Public Meetings (2)								M																																									
Task 4																																																	
Concept Development																																																	
Preferred Conceptual Design																																																	
Public Meeting (1)																					M																												
Task 5																																																	
Draft documentation																																																	
City review																																																	
Public comment																																																	
Final Report																																									M								

Fee Estimate

The table below shows our draft fee estimate for the project. Toole Design has an audited overhead rate of 179.36% that has been approved for our home office in Maryland, as well as by 12 other state departments of transportation. Approval by INDOT is pending.

Staff Name	Toole Design Group								Herd Strategies		Task Hourly Subtotals	Task Labor Subtotals
	Ciara Schlichting	Drew Parker	Cindy Zerger	Mariel Colman	Emily Koehle	Sarah Grossi	Hadar Albo	Jaz Warren	TBD	TBD		
Project Role	Principal-in-Charge	Project Manager	Urban Design Lead	Project Engineer	Traffic Engineer	Planner	Traffic Analyst	Designer	Principal	Associate		
Billing Category	Planning Lead II	Senior Planner	Planning Lead I	Engineer II	Engineer II	Planner	Engineer II	Planner	Principal	Associate		
Raw Rate	\$81.99	\$55.12	\$76.66	\$47.22	\$45.99	\$32.07	\$37.53	\$33.08	n/a	n/a		
Overhead (179.36%)	\$147.06	\$98.86	\$137.49	\$84.69	\$82.48	\$57.51	\$67.31	\$59.33	n/a	n/a		
Fixed Fee (10%)	\$22.91	\$15.40	\$21.41	\$13.19	\$12.85	\$8.96	\$10.48	\$9.24	n/a	n/a		
Loaded Rate	\$251.96	\$169.37	\$235.56	\$145.10	\$141.32	\$98.54	\$115.32	\$101.65	\$180	\$120		
1: Work Plan and Project Management												
Work and Public Involvement Plan	2	2		4							8	\$1,423.06
Project Survey and website		2				12			2		16	\$1,881.22
Project Kickoff Meeting	2	4		6						2	14	\$2,292.00
PMT Meetings (12)		12		12	4	12					40	\$5,521.40
SC Meetings (4)		8		20		12			8		48	\$6,879.44
Progress Reports (12)	4			12		12				12	40	\$5,371.52
Subtotal Hours	8	28	0	54	4	48	0	0	10	14	166	
Subtotal Cost	\$2,015.68	\$4,742.36	\$0.00	\$7,835.40	\$565.28	\$4,729.92	\$0.00	\$0.00	\$1,800.00	\$1,680.00		\$23,368.64
2. Existing Conditions Multimodal Analysis												
Background Research and Needs Assessment		2			8	12					22	\$2,651.78
Vehicular Analysis and Data Collection processing		2			8		24				34	\$4,236.98
BLTS, ped analysis, transit mapping		2			4	24					30	\$3,268.98
Big Data Analysis		3			12		12				27	\$3,587.79
Crash data analysis		2			4	30					36	\$3,860.22
Exhibit preparation	2	4			8	16					30	\$3,888.60
Subtotal Hours	2	15	0	0	44	82	36	0	0	0	179	
Subtotal Cost	\$503.92	\$2,540.55	\$0.00	\$0.00	\$6,218.08	\$8,080.28	\$4,151.52	\$0.00	\$0.00	\$0.00		\$21,494.35
3. Design Charrette												
Prepare for charrette		8	4	12				20	4	20	68	\$9,191.40
Participate in design charrette		10	40					40	20	20	130	\$21,182.10
Subtotal Hours	0	18	44	12	0	0	0	60	24	40	198	
Subtotal Cost	\$0.00	\$3,048.66	\$10,364.64	\$1,741.20	\$0.00	\$0.00	\$0.00	\$6,099.00	\$4,320.00	\$4,800.00		\$30,373.50

4. Concept Development												
Two concept alternatives	2	10	4	20		30	24	12			102	\$12,985.54
Multimodal analysis for initial concepts		2		3		3	10				18	\$2,222.86
Draft preferred alternative & analysis	2	15	8	10	20	40	30	15			140	\$18,132.30
Final preferred alternative	2	10	4	15	5	30		10			76	\$9,995.66
Multimodal analysis for final preferred alternative		4			8	20	30				62	\$7,238.44
Cost estimate		2	2	10							14	\$2,260.86
Public Meeting to present preferred alternative		8						8	12	12	40	\$5,768.16
Subtotal Hours	6	51	18	58	33	123	94	45	12	12	452	
Subtotal Cost	\$1,511.76	\$8,637.87	\$4,240.08	\$8,415.80	\$4,663.56	\$12,120.42	\$10,840.08	\$4,574.25	\$2,160.00	\$1,440.00		\$58,603.82
5. Final Documentation												
Draft content	2	8		20		50		20			100	\$11,720.88
Address comments and finalize plan	2	4		16		20		10			52	\$6,490.30
Subtotal Hours	4	12	0	36	0	70	0	30	0	0	152	
Subtotal Cost	\$1,007.84	\$2,032.44	\$0.00	\$5,223.60	\$0.00	\$6,897.80	\$0.00	\$3,049.50	\$0.00	\$0.00		\$18,211.18
Direct Expenses												
Traffic counts, Big Data												\$13,000.00
Travel for Charrette and final public meeting												\$4,900.00
Total Hours	20	124	62	160	81	323	130	135	46	66	1,147	
Labor (includes overhead and fee)	\$5,039.20	\$21,001.88	\$14,604.72	\$23,216.00	\$11,446.92	\$31,828.42	\$14,991.60	\$13,722.75	\$8,280.00	\$7,920.00		\$152,051.49
Grand Total												\$169,951.49

AGREEMENT FOR PROFESSIONAL SERVICES

THIS AGREEMENT is entered into by and between the City of Bloomington Planning and Transportation Department by and through the Board of Public Works (“City”), and Toole Design Group, LLC (“Consultant”).

WHEREAS, the City wishes to hire a consultant to develop a corridor study and conceptual design for College Avenue and Walnut Street from the 45/46 Bypass to Allen Street (“Study”); and

WHEREAS, the City requires the services of a professional consultant to prepare the Study and provide it to the City (“Services”) and which are more fully set forth below; and

WHEREAS, Consultant was selected after the City issued a Request for Information, has the experience, and professional expertise and is willing and able to provide such Services to the City; and

WHEREAS, it is in the public interest that such Services be undertaken and performed’

NOW, THEREFORE, in consideration of the mutual covenants herein contained, the parties hereto agree as follows:

1. **Effective Date, Term and Termination.** The effective date for this Agreement is the date last entered in the signature blocks below. This Agreement shall commence on the effective date and expire on the December 31, 2023.

In the event of a party’s substantial failure to perform in accordance with the terms of this Agreement, the other party shall have the right to terminate the Agreement upon written notice. The nonperforming party shall have fourteen (14) calendar days from the receipt of the termination notice to cure or to submit a plan for cure acceptable to the other party. Additionally, the City may terminate or suspend performance of this Agreement at the City’s prerogative at any time upon five (5) days written notice to Contractor. Contractor shall terminate or suspend performance of the Services on a schedule acceptable to the City and the City shall pay the Contractor for all the Services performed up to the date that written notice is received, plus reasonable termination or suspension expenses. Upon restart, an equitable adjustment shall be made to Contractor’s compensation and the schedule of services. Upon termination or suspension of this Agreement, all finished or unfinished reports, drawings, collections of data and other documents generated by Contractor in connection with this Agreement shall become the property of the City.

2. **Compensation.** The City shall pay Consultant for all fees and expenses for all Services herein provided in an amount not to exceed one hundred seventy thousand dollars (\$170,000). Consultant shall submit an invoice to the City upon the completion of the Services described herein. The invoice shall be sent to: Beth Rosenbarger, City of Bloomington, 401 N. Morton Street, Bloomington, Indiana 47404. Invoices may be sent via

first class mail postage prepaid or via email. Payment will be remitted to Consultant within forty-five (45) days of receipt of invoice. Additional services and/or any changes in the Services not set forth herein shall be authorized in writing by the City or its designated project coordinator prior to such work being performed or any expenses incurred by Consultant. The City shall not make payment for any unauthorized work or expenses. No additional work shall be performed until and unless additional funding is approved and an amendment to this Agreement reached by both parties herein.

3. **Scope of Services.** Consultant shall provide required Services for the City which are more fully set forth in the Scope of Services attached hereto, marked as **Exhibit "A"**, and by this reference incorporated herein. Time is of the essence and Consultant shall diligently complete all Services in a timely manner consistent with the Standard of Care identified below.
4. **Standard of Care.** Consultant shall be responsible for completion of the Services in a manner sufficient to meet the professional standards consistent with that of the industry. The City shall be the sole judge of the adequacy of Consultant's work in meeting such standards. However, the City shall not unreasonably withhold its approval as to the adequacy of such performance.
5. **Responsibilities of the City.** The City shall provide all necessary information regarding requirements for the Services. The City shall furnish such information as expeditiously as is necessary for the orderly progress of the work, and Consultant shall be entitled to rely upon the accuracy and completeness of such information. The City shall designate in the Notice section below who is authorized to act on its behalf with respect to this Agreement.
6. **Appropriation of Funds.** Notwithstanding any other provision of this Agreement, if funds for the continued fulfillment of this Agreement by the City are at any time not forthcoming or are insufficient, through failure of any entity to appropriate funds or otherwise, then the City shall have the right to terminate this Agreement without penalty as set forth below.
7. **Schedule.** The project shall be completed in accordance with the schedule set forth in Exhibit B, "Project Schedule."
8. **Identity of Consultant.** Consultant acknowledges that one of the primary reasons for its selection by the City to perform the duties described in this Agreement is the qualification and experience of the principal personnel whom Consultant has represented will be responsible therefor. Therefore the City reserves the right to reject any of the Consultant's personnel or proposed outside professional sub-consultants, and the City reserves the right to request that acceptable replacement personnel be assigned to the project.
9. **Ownership of Documents and Intellectual Property.** Consultant agrees that any information or documents, including digital GIS information, supplied by the City shall be used by Consultant for this project only, and shall not be reused or reassigned for any purpose. All documents, drawings and specifications, including digital format files, prepared by Consultant and furnished to the City as part of the Services shall become the property of

the City. Consultant shall retain its ownership rights in its design, drawing details, specifications, data bases, computer software and other proprietary property. Intellectual property developed, utilized or modified in the performance of the Services shall remain the property of the Consultant.

- 10. Reuse of Documents.** All documents, including but not limited to, drawings, specifications and computer software prepared by Consultant pursuant to this Agreement are instruments of service in respect to this project. They are not intended or represented to be suitable for reuse by the City or others on modifications or extensions of this project or on any other project. The City may elect to reuse such documents; however any reuse without prior written verification or adaptation by Consultant for the specific purpose intended will be at the City's sole risk and without liability or legal exposure to the Consultant. The City shall indemnify and hold harmless the Consultant against all judgments, losses, damages, injuries and expenses arising out of or resulting from such reuse. Any verification or adaptation of documents by the Consultant will entitle the Consultant to additional compensation at rates to be agreed upon by the City and the Consultant.
- 11. Independent Contractor Status.** During the entire term of this Agreement, Consultant shall be an independent contractor, and in no event shall any of its personnel, agents or sub-contractors be construed to be, or represent themselves to be, employees of the City. Consultant shall be solely responsible for the payment and reporting of all employee and employer taxes, including social security, unemployment, and any other federal, state, or local taxes required to be withheld from employees or payable on behalf of employees.
- 12. Indemnification.** Consultant shall indemnify and hold harmless the City of Bloomington, its directors, officers, agents and employees of the City from and against all claims, demands, damages, costs, expenses or other liability, including reasonable attorney's fees and defense costs, to the extent caused by the Consultant's negligent performance of Professional services under this Agreement and that of its Sub-consultants or anyone for whom the Consultant is legally liable.
- 13. Cost Estimates.** All estimates of construction cost to be provided by Consultant shall represent the best judgment of Consultant based upon the information currently available and Consultant's background and experience with respect to projects of this nature. It is recognized, however, that neither Consultant nor the City has control over the cost of labor, materials or equipment, over contractors' method of determining costs for services, or over competitive bidding, market or negotiating conditions. Accordingly, Consultant cannot and does not warrant or represent that the proposals or construction bids received will not vary from the cost estimates provided pursuant to the Agreement.
- 14. Insurance.** During the performance of any and all Services under this Agreement, Consultant shall maintain the following insurance in full force and effect:

 - A. General Liability Insurance, with a minimum combined single limit of \$1,000,000 for each occurrence and \$2,000,000 in the aggregate.

- B. Automobile Liability Insurance, with a minimum combined single limit of \$1,000,000 for each person and \$1,000,000 for each accident.
- C. Professional Liability Insurance (“Errors and Omissions Insurance”) with a minimum limit of \$1,000,000 annual aggregate.
- D. Workers’ Compensation Insurance in accordance with the statutory requirements of Title 22 of the Indiana Code.

All insurance policies shall be issued by an insurance company authorized to issue such insurance in the State of Indiana. The City of Bloomington, its agents, officers, board members and employees shall be named as additional insureds under the General Liability and Automobile Liability policies, and such policies shall stipulate that the insurance will operate as primary insurance and that no other insurance affected by the City will be called upon to contribute to a loss hereunder. Consultant shall provide at least 30 days notice to City prior to any cancellation/termination of any or all insurance policies.

Consultant shall provide evidence of each insurance policy to the City prior to the commencement of work under the Agreement. Approval of the insurance by the City shall not relieve or decrease the extent to which Consultant may be held responsible for payment of damages resulting from service or operations performed pursuant to this Agreement. If Consultant fails or refuses to procure or maintain the insurance required by these provisions, or fails or refuses to furnish the City required proof that the insurance has been procured and is in force and paid for, City shall have the right at City’s election to forthwith terminate the Agreement.

- 15. **Conflict of Interest.** Consultant declares that it has no present interest, nor shall it acquire any interest, direct or indirect, which would conflict with the performance of Services required under this Agreement. The Consultant agrees that no person having any such interest shall be employed in the performance of this Agreement.
- 16. **Waiver.** No failure of either party to enforce a term of this Agreement against the other shall be construed as a waiver of that term, nor shall it in any way affect the party’s right to enforce that term. No waiver by any party of any term of this Agreement shall be considered to be a waiver of any other term or breach thereof.
- 17. **Severability.** The invalidity, illegality or unenforceability of any provision of this Agreement or the occurrence of any event rendering any portion or provision of this Agreement void shall in no way affect the validity or enforceability of any other portion or provision of this Agreement. Any void provision shall be deemed severed from this Agreement, and the balance of the Agreement shall be construed and enforced as if it did not contain the particular provision to be held void. The parties further agree to amend this Agreement to replace any stricken provision with a valid provision that comes as close as possible to the intent of the stricken provision. The provisions of this Article shall not prevent this entire

Agreement from being void should a provision which is of the essence of this Agreement be determined void.

18. **Assignment.** Neither the City nor the Consultant shall assign any rights or duties under this Agreement without the prior written consent of the other party; provided, however, Consultant may assign its rights to payment without the City's consent. Unless otherwise stated in the written consent to an assignment, no assignment will release or discharge the assignor from any obligation under this Agreement.
19. **Third Party Rights.** Nothing in this Agreement shall be construed to give any rights or benefits to anyone other than the City and the Consultant.
20. **Governing Law and Venue.** This Agreement shall be governed by the laws of the State of Indiana. Venue of any disputes arising under this Agreement shall be in Monroe County, Indiana.
21. **Non-Discrimination.** Consultant shall comply with City of Bloomington Ordinance 2.21.020 and all other federal, state and local laws and regulations governing non-discrimination, including but not limited to employment. Consultant understands that the City of Bloomington prohibits its employees from engaging in harassment or discrimination of any kind, including harassing or discriminating against independent contractors doing work for the City. If Consultant believes that a City employee engaged in such conduct towards Consultant and/or any of its employees, Consultant or its employees may file a complaint with the City Department head in charge of the Contractor's work, and/or with the human resources department or the Bloomington Human Rights Commission. The City takes all complaints of harassment and discrimination seriously and will take appropriate disciplinary action if it finds that any City employee engaged in such prohibited conduct. Any breach of this section is a material breach and will be cause for termination of this Agreement.
22. **Verification of New Employees' Immigration Status.** Consultant is enrolled in, and verifies the work eligibility status of all newly-hired employees through, the E-Verify program. (This is not required if the E-Verify program no longer exists). Consultant signed an e-verify affidavit, attached hereto, marked as **Exhibit "C"**, and by this reference incorporated herein.

Consultant may not knowingly employ or contract with an unauthorized alien, or retain an employee or contract with a person that the contractor subsequently learns is an unauthorized alien. If the City obtains information that the Consultant employs or retains an employee who is an unauthorized alien, the City shall notify the Consultant of the contract violation and require that the violation be remedied within 30 days of the date of notice. If the Consultant verified the work eligibility status of the employee in question through the E-Verify program, there is a rebuttable presumption that the Consultant did not knowingly employ an unauthorized alien. If the Consultant fails to remedy the violation within the 30 day period, the City shall terminate the contract unless the City determines that terminating the contract would be detrimental to the public interest or public property, in which case the City may

allow the contract to remain in effect until the City procures a new Consultant. If the City terminates the contract, the Consultant is liable to the City for actual damages.

23. **Non-Collusion.** Consultant certifies that it has not, nor has any other member, representative, or agent of Consultant, entered into any collusion by agreement or otherwise with any person relative to the price to be offered by any person nor prevented any person from making an offer nor induced anyone to refrain from making an offer and that this offer is made without reference to any other offer. Consultant signed the non-collusion affidavit attached hereto, marked as **Exhibit “D”** and by this reference incorporated herein.
24. **Compliance with Laws.** In performing the Services under this Agreement, Consultant shall comply with any and all applicable federal, state and local statutes, ordinances, plans and regulations, including any and all regulations for protection of the environment. Where such statutes, ordinances, plans or regulations of any public authority having any jurisdiction on the project are in conflict, Consultant shall proceed using its best judgment only after attempting to resolve any such conflict between such governmental agencies, and shall notify the City in a timely manner of the conflict, attempts of resolution, and planned course of action.
25. **Notices.** Any notice required by this Agreement shall be made in writing to the individuals/addresses specified below:

TO CITY:	TO CONTRACTOR:
City of Bloomington Planning and Transportation Department	Toole Design Group, LLC
ATTN: Beth Rosenbarger, Project Manager	Attn: Drew Parker, Project Manager
401 N. Morton Street, Suite 130	8484 Georgia Avenue, Suite 800
Bloomington, IN 47401	Silver Spring, MD 20910

Nothing contained in this Article shall be construed to restrict the transmission of routine communications between representatives of the City and Contractor.

26. **Intent to be Bound.** The City and the Consultant each bind itself and its successors, executors, administrators, permitted assigns, legal representatives and, in the case of a partnership, its partners to the other party to this Agreement, and to the successors, executors, administrators, permitted assigns, legal representatives and partners of such other party in respect to all provisions of this Agreement.
27. **Integration and Modification.** This Agreement, including all Exhibits incorporated by reference, represents the entire and integrated agreement between the City and the Consultant. This Agreement supersedes any and all prior and contemporaneous communications, representations and agreements, whether oral or written, relating to the subject matter of this Agreement. This Agreement may be modified only by a written amendment signed by both parties hereto.

IN WITNESS WHEREOF, the parties hereto have caused this Agreement to be executed the day and year first written above.

CITY OF BLOOMINGTON

BY:

Kyla Cox Deckard, Chair DATED
Board of Public Works

Scott Robinson, Director DATED
Bloomington Planning & Transportation

John Hamilton, Mayor DATED
City of Bloomington

TOOLE DESIGN GROUP, LLC

BY:

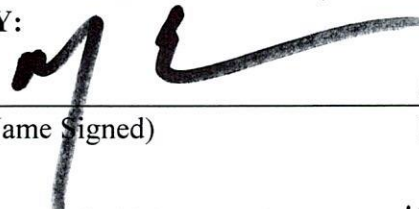
 _____ 10/3/22
(Name Signed) DATED

Roswell Eldridge 10/3/22
(Name Printed) DATED

Executive Vice President/COO
(Title)

EXHIBIT A

“Scope of Work”

See attached scope of work. Attach pages 2 through 6 of RFI (from “General Information and Summary” and stopping at “Submittal Requirements”)

EXHIBIT B

“Project Schedule”

See Scope of Work.

EXHIBIT C

STATE OF INDIANA)
)SS:
COUNTY OF MONROE)

E-VERIFY AFFIDAVIT

The undersigned, being duly sworn, hereby affirms and says that:

1. The undersigned is the Executive Vice President/COO of Toole Design Group, LLC.
(job title) (company name)
2. The company named herein that employs the undersigned:
 - i. has contracted with or seeking to contract with the City of Bloomington to provide services; **OR**
 - ii. is a subcontractor on a contract to provide services to the City of Bloomington.
3. The undersigned hereby states that, to the best of his/her knowledge and belief, the company named herein does not knowingly employ an "unauthorized alien," as defined at 8 United States Code 1324a(h)(3).
4. The undersigned hereby states that, to the best of his/her belief, the company named herein is enrolled in and participates in the E-verify program.

[Signature]
Signature
Roswell Eldridge
Printed Name

STATE OF Maryland)
)SS:
COUNTY OF Montgomery)

Before me, a Notary Public in and for said County and State, personally appeared Roswell Eldridge and acknowledged the execution of the foregoing this 3 day of October, 2022.

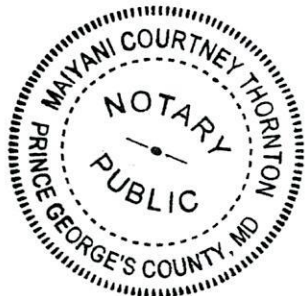

Maiyani C Thornton
Notary Public's Signature
Maiyani Courtney Thornton
Printed Name of Notary Public
My Commission Expires: 11/21/2023
County of Residence: Prince George's
Commission Number: 251758

EXHIBIT D

STATE OF _____)
) SS:
COUNTY OF _____)

NON-COLLUSION AFFIDAVIT

The undersigned offeror or agent, being duly sworn on oath, says that he has not, nor has any other member, representative, or agent of the firm, company, corporation or partnership represented by him, entered into any combination, collusion or agreement with any person relative to the price to be offered by any person nor to prevent any person from making an offer nor to induce anyone to refrain from making an offer and that this offer is made without reference to any other offer.

OATH AND AFFIRMATION

I affirm under the penalties of perjury that the foregoing facts and information are true and correct to the best of my knowledge and belief.

Dated this 3 day of October, 2022.

Toole Design Group, LLC

Signature

Executive Vice President/COO

Title

STATE OF Maryland)
) SS:
COUNTY OF Montgomery)

Before me, a Notary Public in and for said County and State, personally appeared Roswell Eldridge and acknowledged the execution of the foregoing this 3 day of October, 2022.

Maiyani Courtney Thornton
Notary Public's Signature

Maiyani Courtney Thornton
Printed Name of Notary Public

My Commission Expires on: 11/21/2023

Commission Number: 251758





Board of Public Works Staff Report

Project/Event: Change Order #2, #3, and #4 for the Neighborhood Greenways Project

Petitioner/Representative: Engineering Department

Staff Representative: Sara Gomez

Meeting Date: October 11, 2022

This project was awarded to Rivertown Construction, LLC. The contract included the installation of ADA ramps, concrete curbs, asphalt speed cushions, pavement markings and signs. The original contract amount for the project was \$439,876.10.

Change Order #2 is a request from the contractor to add pavement marking installation on E 7th St for a total contract adjustment of \$7,000.00. This item was not part of the original contract and was to be completed by the City Street Department.

Change Order #3 is a request from the contractor for an extension of the contract by 4 days.

Change Order #4 will balance all of the pay items on the contract for an addition of \$1,286.66 to the project total. The change orders will add a total of \$8,286.76 to the contract, and the total adjusted contract amount is \$448,162.76.

This project is funded through the 176-07-G21005-54310 (2022 ARPA).

City of Bloomington Contract and Purchase Justification Form

Vendor: Rivertown Construction, LLC

Contract Amount: \$439,876.10

This form should be completed and attached to the contract documents and forwarded to the Legal Department Attorney assigned to your Department. Contracts will not be approved by the Controller if a completed form is not included with the contract documents.

PURCHASE INFORMATION

1. Check the box beside the procurement method used to initiate this procurement: (Attach a quote or bid tabulation if applicable)

<input type="checkbox"/> Request for Quote (RFQ)	<input type="checkbox"/> Request for Proposal (RFP)	<input type="checkbox"/> Sole Source	<input checked="" type="checkbox"/> Not Applicable (NA)
<input type="checkbox"/> Invitation to Bid (ITB)	<input type="checkbox"/> Request for Qualifications (RFQu)	<input type="checkbox"/> Emergency Purchase	

2. List the results of procurement process. Give further explanation where requested. Yes No

# of Submittals:	Yes	No	Was the lowest cost selected? (If no, please state below why it was not.)	Yes	No
Met city requirements?	<input checked="" type="checkbox"/>	<input type="checkbox"/>		<input checked="" type="checkbox"/>	<input type="checkbox"/>
Met item or need requirements?	<input checked="" type="checkbox"/>	<input type="checkbox"/>			
Was an evaluation team used?	<input type="checkbox"/>	<input checked="" type="checkbox"/>			
Was scoring grid used?	<input type="checkbox"/>	<input checked="" type="checkbox"/>			
Were vendor presentations requested?	<input type="checkbox"/>	<input checked="" type="checkbox"/>			

3. State why this vendor was selected to receive the award and contract:

The contract with Rivertown Construction, LLC for the Neighborhood Greenways Project, Phase 1 was approved by the BPW on December 21st, 2021. These 3- change orders are being presented in compliance with the contract documents for the Neighborhood Greenways Project.

Original: \$439,876.10

Previous Change Orders: \$0.00

Change Orders #2, #3, and #4: \$8286.66

Sara Gomez

Project Manager

Engineering

Print/Type Name

Print/Type Title

Department



City of Bloomington, Indiana

Change Order Details

Neighborhood Greenways Project Phase 1

Description	<i>Neighborhood Greenways using traffic calming to create a comfortable shared space street, East 7th Street (Union St to Overhill Dr.) W Graham and Ralston Drives (Rockport Rd. to Bryan Street).</i>
Prime Contractor	River Town Construction, LLC PO Box 444 Newburg, IN 47629
Change Order	2
Status	Pending
Date Created	09/22/2022
Type	Other
Summary	Pavement Markings installed by Rivertown outside Contract Specifications
Change Order Description	Pavement Markings on E 7th St were, per plans and contract, to be installed by the City of Bloomington Street Department. The subcontractor for Rivertown Construction (ISB) installed the pavement markings on E 7th St without permission from the City to do so. The contractor requested a change order to cover the costs of installation the City would have spent had they installed them. Due to not having an item for 'Labor' costs, the labor costs have been added into the item quantities.
Awarded Project Amount	\$439,876.10
Authorized Project Amount	\$439,876.10
Change Order Amount	\$7,000.00
Revised Project Amount	\$446,876.10

Increases/Decreases

Line Number	Item ID	Unit	Unit Price	Current		Change		Revised	
				Quantity	Amount	Quantity	Amount	Quantity	Amount
Section: 1 - Description									
0320	808-02977	EACH	\$250.000	19.000	\$4,750.00	9.000	\$2,250.00	28.000	\$7,000.00
PAVEMENT MESSAGE MARKING, THERMOPLASTIC, BIKE SYMBOL									
Reason: Contractor installed over contract amount									
0330	808-03439	LFT	\$7.000	109.000	\$763.00	32.000	\$224.00	141.000	\$987.00
TRANSVERSE MARKING, THERMOPLASTIC, CROSSWALK LINE, WHITE, 24 IN.									
Reason: Contractor installed over contract amount									
0340	808-05929	LFT	\$2.210	110.000	\$243.10	174.660	\$386.00	284.660	\$629.10
TRANSVERSE MARKING, THERMOPLASTIC, CROSSWALK LINE, WHITE, 8 IN.									
Reason: Contractor installed over contract amount									
0350	808-04096	EACH	\$400.000	19.000	\$7,600.00	10.000	\$4,000.00	29.000	\$11,600.00
PAVEMENT MESSAGE MARKING, THERMOPLASTIC, LANE									
Reason: Contractor installed over contract amount									
0370	808-75297	LFT	\$7.000	19.000	\$133.00	20.000	\$140.00	39.000	\$273.00
TRANSVERSE MARKING, THERMOPLASTIC, STOP LINE, WHITE, 24 IN.									

Line Number	Item ID	Unit	Unit Price	Current		Change		Revised	
				Quantity	Amount	Quantity	Amount	Quantity	Amount

Reason: Contractor installed over contract amount

5 items	Totals			\$13,489.10		\$7,000.00		\$20,489.10
---------	--------	--	--	-------------	--	------------	--	-------------

Attachments

Document	Name	Description	Submission Date
Change_Order_Request_Pavement_Markings.pdf	Change Order Request_Pavement Markings.pdf	Original CO Request	09/22/2022 03:41 PM EDT
City_of_Bloomington_Indiana_Mail_-_7th_St_pavement_markings.pdf	City of Bloomington, Indiana Mail - 7th St pavement markings.pdf	Street Dept estimated labor cost for PM installation on E 7th St	09/22/2022 03:43 PM EDT
Ennis-Flint_267244__4004.70.pdf	Ennis-Flint 267244 \$4004.70.pdf	Street Dept. cost for thermo @ E 7th St	09/22/2022 03:41 PM EDT
UPDATED-Change_Order_Request_Pavement_Markings.pdf	UPDATED-Change Order Request_Pavement Markings.pdf	Updated CO request	09/22/2022 03:41 PM EDT
4 attachments			

Not valid until signed by the Engineer, Contractor, and Owner



Engineer



Contractor

Board of Public Works

City Engineer

Title

Project Manager

Title

Title

10/7/2022

Date

9-23-2022

Date

Date



City of Bloomington, Indiana

Change Order Details

Neighborhood Greenways Project Phase 1

Description	<i>Neighborhood Greenways using traffic calming to create a comfortable shared space street, East 7th Street (Union St to Overhill Dr.) W Graham and Ralston Drives (Rockport Rd. to Bryan Street).</i>
Prime Contractor	River Town Construction, LLC PO Box 444 Newburg, IN 47629
Change Order	3
Status	Pending
Date Created	09/22/2022
Type	Changed Conditions
Summary	Contract Extension
Change Order Description	<p>The last items to be placed on this project were the speed cushion markings on Ralston Avenue, which were completed on August 25th, or 26 Calendar Days after the original completion date of July 30th, 2022.</p> <p>Rivertown claims they experienced 9 rain events in May, 4 rain events in June, 7 rain events in July and that it rained 3 days in August. In accordance with Construction Memo 19-05 and SS 101.02, the maximum number of allowable inclement weather days for this time period is four.</p> <p>At Rivertown's request, we agree that the installation of the speed cushion markings on Ralston were complicated by confusion caused in coordinating scheduling. With that that decision made, the last day of work would be considered August 5th, the day that the pavement markings were installed on Graham. This places the contract six days past the original completion date. Rivertown delivered a construction schedule that indicates that the rain days experienced throughout the project did in fact impair the controlling operation, the City considered this and is willing to accept Rivertown's request for a change order adding four additional days to the contract.</p> <p>This leaves two days to be charged as liquidating damages in the amount of \$1,000.00 which will be a separate change order.</p>

Awarded Project Amount \$439,876.10
Authorized Project Amount \$439,876.10
Change Order Amount \$0.00
Revised Project Amount \$439,876.10

Time Limit Changes

Type	Original Deadline	Current Deadline	Pending Extension	Pending Deadline
Calendar Days	90.0 Days	90.0 Days	4.0 Days	94.0 Days
90 Calendar Days to complete the work with the first day of work being no later than May 2, 2022 and final completion being no later than July 30, 2022. Reason: extension				
1 time limit				

Not valid until signed by the Engineer, Contractor, and Owner

<u>Andrew Cibor</u>	<u>River town</u> <u>Chad [Signature]</u>	
Engineer	Contractor	Board of Public Works
<u>City Engineer</u>	<u>Project Manager</u>	
Title	Title	Title
<u>10/3/2022</u>	<u>9-30-2022</u>	
Date	Date	Date



City of Bloomington, Indiana

Change Order Details

Neighborhood Greenways Project Phase 1

Description	<i>Neighborhood Greenways using traffic calming to create a comfortable shared space street, East 7th Street (Union St to Overhill Dr.) W Graham and Ralston Drives (Rockport Rd. to Bryan Street).</i>
Prime Contractor	River Town Construction, LLC PO Box 444 Newburg, IN 47629
Change Order	4
Status	Pending
Date Created	09/27/2022
Summary	Balancing Change Order for Final Payment
Change Order Description	Balancing Change Order for Final Payment
Awarded Project Amount	\$439,876.10
Authorized Project Amount	\$446,876.10
Change Order Amount	\$1,286.66
Revised Project Amount	\$448,162.76

Increases/Decreases

Line Number	Item ID	Unit	Unit Price	Current		Change		Revised	
				Quantity	Amount	Quantity	Amount	Quantity	Amount
Section: 1 - Description									
0050	304-12624	TON	\$280.000	12.000	\$3,360.00	-2.000	-\$560.00	10.000	\$2,800.00
HMA PATCHING PARTIAL DEPTH TYPE B									
Reason: Balancing Change Order									
0060	305-07468	SYS	\$55.000	135.000	\$7,425.00	35.330	\$1,943.15	170.330	\$9,368.15
PCC BASE PATCHING, 12 IN.									
Reason: Balancing Change Order									
0090	604-06070	SYS	\$115.000	207.000	\$23,805.00	69.550	\$7,998.25	276.550	\$31,803.25
SIDEWALK, CONCRETE									
Reason: Balancing Change Order									
0100	604-08086	SYS	\$225.000	104.000	\$23,400.00	-4.360	-\$981.00	99.640	\$22,419.00
CURB RAMP, CONCRETE									
Reason: Balancing Change Order									
0110	604-12083	SYS	\$640.000	31.000	\$19,840.00	-4.320	-\$2,764.80	26.680	\$17,075.20
DETECTABLE WARNING SURFACES									

Line Number	Item ID	Unit	Unit Price	Current		Change		Revised	
				Quantity	Amount	Quantity	Amount	Quantity	Amount

Reason: Balancing Change Order

0120	605-06120	LFT	\$50.000	1,006.000	\$50,300.00	32.910	\$1,645.50	1,038.910	\$51,945.50
------	-----------	-----	----------	-----------	-------------	--------	------------	-----------	-------------

CURB, CONCRETE

Reason: Balancing Change Order

0130	605-06125	LFT	\$150.000	59.000	\$8,850.00	2.300	\$345.00	61.300	\$9,195.00
------	-----------	-----	-----------	--------	------------	-------	----------	--------	------------

CURB, CONCRETE, MODIFIED

Reason: Balancing Change Order

0140	605-06140	LFT	\$34.000	57.000	\$1,938.00	12.100	\$411.40	69.100	\$2,349.40
------	-----------	-----	----------	--------	------------	--------	----------	--------	------------

CURB AND GUTTER, CONCRETE

Reason: Balancing Change Order

0170	621-06575	SYS	\$20.000	339.205	\$6,784.10	-339.205	-\$6,784.10	0.000	\$0.00
------	-----------	-----	----------	---------	------------	----------	-------------	-------	--------

SODDING, NURSERY

Reason: Balancing Change Order

0200	801-04308	EACH	\$214.000	4.000	\$856.00	-4.000	-\$856.00	0.000	\$0.00
------	-----------	------	-----------	-------	----------	--------	-----------	-------	--------

ROAD CLOSURE SIGN ASSEMBLY

Reason: Balancing Change Order

Line Number	Item ID	Unit	Unit Price	Current		Change		Revised	
				Quantity	Amount	Quantity	Amount	Quantity	Amount
0240	802-05704	LFT	\$25.000	324.000	\$8,100.00	24.000	\$600.00	348.000	\$8,700.00
SIGN POST, SQUARE TYPE 1 UNREINFORCED ANCHOR BASE									
Reason: Balancing Change Order									
0250	802-07060	EACH	\$100.000	10.000	\$1,000.00	-3.000	-\$300.00	7.000	\$700.00
SIGN, SHEET, RELOCATE									
Reason: Balancing Change Order									
0260	802-09838	SFT	\$30.000	121.000	\$3,630.00	12.500	\$375.00	133.500	\$4,005.00
SIGN, SHEET, WITH LEGEND, 0.080 IN.									
Reason: Balancing Change Order									
0320	808-02977	EACH	\$250.000	28.000	\$7,000.00	1.000	\$250.00	29.000	\$7,250.00
PAVEMENT MESSAGE MARKING, THERMOPLASTIC, BIKE SYMBOL									
Reason: Balancing Change Order									
0330	808-03439	LFT	\$7.000	141.000	\$987.00	-17.000	-\$119.00	124.000	\$868.00
TRANSVERSE MARKING, THERMOPLASTIC, CROSSWALK LINE, WHITE, 24 IN.									
Reason: Balancing Change Order									
0340	808-05929	LFT	\$2.210	284.660	\$629.10	6.000	\$13.26	290.660	\$642.36
TRANSVERSE MARKING, THERMOPLASTIC, CROSSWALK LINE, WHITE, 8 IN.									

Change Order Details:

Neighborhood Greenways Project Phase 1

09/27/2022

Page 4 of 6

Line Number	Item ID	Unit	Unit Price	Current		Change		Revised	
				Quantity	Amount	Quantity	Amount	Quantity	Amount
Reason: Balancing Change Order									
0350	808-04096	EACH	\$400.000	29.000	\$11,600.00	1.000	\$400.00	30.000	\$12,000.00
PAVEMENT MESSAGE MARKING, THERMOPLASTIC, LANE									
Reason: Balancing Change Order									
0380	808-09314	LFT	\$1.100	3,500.000	\$3,850.00	-300.000	-\$330.00	3,200.000	\$3,520.00
LINE, PAINT, SOLID, BLUE, 4 IN.									
Reason: Balancing Change Order									
18 items			Totals		\$183,354.20		\$1,286.66		\$184,640.86

Not valid until signed by the Engineer, Contractor, and Owner

<u>Andrew Cibor</u>	<u>Rivertown</u>	
Engineer	<u></u> Contractor	Board of Public Works
City Engineer	<u>Project Manager</u>	
Title	Title	Title
<u>10/3/2022</u>	<u>9-30-2022</u>	
Date	Date	Date



Board of Public Works Staff Report

Project/Event: Approve Memorandum of Understanding with the City of Bloomington Utilities Department for Construction Cost Sharing on the W Allen Neighborhood Greenway Project

Petitioner/Representative: Engineering Department

Staff Representative: Neil Kopper, Senior Project Engineer

Date: 10/11/2022

Report: This project will construct improvements to the W Allen Street neighborhood greenway as prioritized by the City’s Transportation Plan. In coordination with the project, the City of Bloomington Utilities Department (CBU) is interested in installing green infrastructure stormwater treatments. This MOU outlines the commitment by CBU to pay for the portion of the project that is associated with the installation of this green infrastructure. Total green infrastructure costs are estimated at \$30,000. Construction will occur in 2023.

<u>Project Approvals Timeline</u>		
<u>Approval Type</u>	<u>Status</u>	<u>Date</u>
Funding Approval – CBU MOU	Current Item	10/11/2022
Design Services Contract	Approved	12/8/2020
ROW Services Contract	N/A	--
Public Need Resolution	N/A	--
Construction Inspection Contract	N/A	--
Construction Contract	Future	Nov 2022

**MEMORANDUM OF UNDERSTANDING
BETWEEN THE CITY OF BLOOMINGTON UTILITIES
AND THE CITY OF BLOOMINGTON ENGINEERING DEPARTMENT
FOR PAYMENT OF CONSTRUCTION FEES RELATED TO THE
W Allen Street Neighborhood Greenway Project**

WHEREAS, the City of Bloomington, Indiana (“City”), pursuant to statutory authority set out in Indiana Code Section 36-4-9-4, has established an Engineering Department (“Engineering”) which acts by and through the City’s Board of Public Works (“BPW”), and, pursuant to statutory authority set out in Indiana Code Section 8-1.5-3-3, has established the City of Bloomington Utilities Department (“CBU”) which acts by and through its Utilities Service Board (“USB”); and,

WHEREAS, Engineering is engaged in the design of neighborhood greenway improvements along the Allen St. corridor between Patterson Drive and Walnut St. within the incorporated limits of the City (“Project”); and,

WHEREAS, the BPW has entered into an agreement with Eagle Ridge Civil Engineering Services, LLC (“Consultant”) to complete the engineering design for the Project; and

WHEREAS, the Project includes the design and construction of green infrastructure storm improvements (i.e., rain gardens) instead of the typical “grey infrastructure” storm components, adding an estimated \$30,000.00 to the construction cost; and

WHEREAS, CBU intends to be responsible for the cost of all green infrastructure related construction costs associated with the Project.

NOW, THEREFORE, in consideration of the mutual covenants, herein contained, the parties hereto agree as follows:

1. Green Infrastructure Rain Garden Construction: CBU shall be responsible for 100% of the costs associated with the construction of the Project’s green infrastructure in an amount estimated not to exceed \$30,000.00.
2. Access to Land: CBU shall work with BPW and Consultant to secure legal authority to enter upon public and private lands as required for the Consultant, agents, independent contractors and the like to perform the services necessary to install the agreed upon green infrastructure so designed by Consultant and approved by CBU.
3. Coordination with Consultant: CBU shall provide access, at no expense to the Consultant, to USB board members, and/or CBU staff, and to all available CBU information pertinent to the Project and the use of such information as appropriate and necessary to perform all design aspects and installation of the green infrastructure associated with the Project.
4. Construction Drawings and Calculations: The BPW, through the Engineering Department, shall provide copies of all construction drawings and calculations related to the green infrastructure improvements associated with the Project from the Consultant to CBU.



Board of Public Works Staff Report

Project/Event: Atlantic Engineering Group (AEG)
Staff Representative: Jason Kerr
Petitioner/Representative: Bret Simons
Date: October 11, 2022

Report: AEG is requesting lane closures and sidewalk closures in multiple locations of their project work areas. This request is to accommodate work on fiber installation via boring and aerial fiber installation. The traffic control would be in place from October 14th through end of project, we're estimating 4 weeks per project area.

AEG has supplied various maintenance of traffic plans for all work. They are also placing door hangers for public notice to property owners about scope of their work and contact information for if there are any issues. (see packet for details).

AEG is requesting for 4 area projects to be granted through this BPW meeting. The following areas include...

E 3 rd St	North to south, this is between E 8 th St and E 3 rd St East to west, this is between Union St and Overhill Dr
N Glenwood Ave	North to south, this is between Longview Ave and Fenbrook Ln East to west, this is between Pleasant Ridge Rd and Romans Way
E Maxwell Ln	North to south, this is between Hunter Ave and Covenant Dr East to west, this is between Manor Rd and Pickwick PI
S Woodcrest Dr	North to south, this is between E 2 nd St and Moores Pike East to west, this is between Pickwick PI and College Mall Rd



P.O. Box 349 | Buford, Georgia 30515
Main Office: (706)654-2298
www.aeg.cc

To: City of Bloomington – Engineering Department
Subject: City of Bloomington Right of Way Application

Dear Board Members,

Atlantic Engineering Group is planning a large FTTH project across the entire City of Bloomington. This work will take place at different locations throughout the year. In order to facilitate these up coming projects, AEG is respectfully requesting access the to ROW as planned out in the submitted permits.

Traffic control plans will be attached to each permit. No long-term road closures or sidewalk closures are expected. Signs and flaggers will be present when needed and move with the project as it moves throughout the city. The areas will all be identified on the plans we submit to the cities Engineering Department.

Proper door hangers will be placed prior to the construction starting in a particular area. The door hangers will provide information about the construction and contact information if any issues arise.

Bret Simons
Project Coordinator
Atlantic Engineering Group



Good News is Coming to Your Neighborhood!

Highline is excited to announce that Fiber Internet will soon be available in the Grand Junction, Mesa County area! Highline representatives will be working on expanding our state-of-the-art fiber optic network right in your hometown. You may be asking, what exactly is Fiber Internet? Fiber is the fastest and most reliable technology to deliver Internet and Wi-Fi services.

Getting Ready

Before we can begin building, we must determine the location of existing underground utilities such as wires, pipes and water lines. Construction crews will mark out the locations of these utilities and the planned installation paths using colored flags.

Note: *Construction areas will be marked with colored flags and paint. Please feel free to mark any private underground facilities that you feel are in the right of way area (such as sprinkler systems, dog fences, etc.) Please do not remove any flags.*

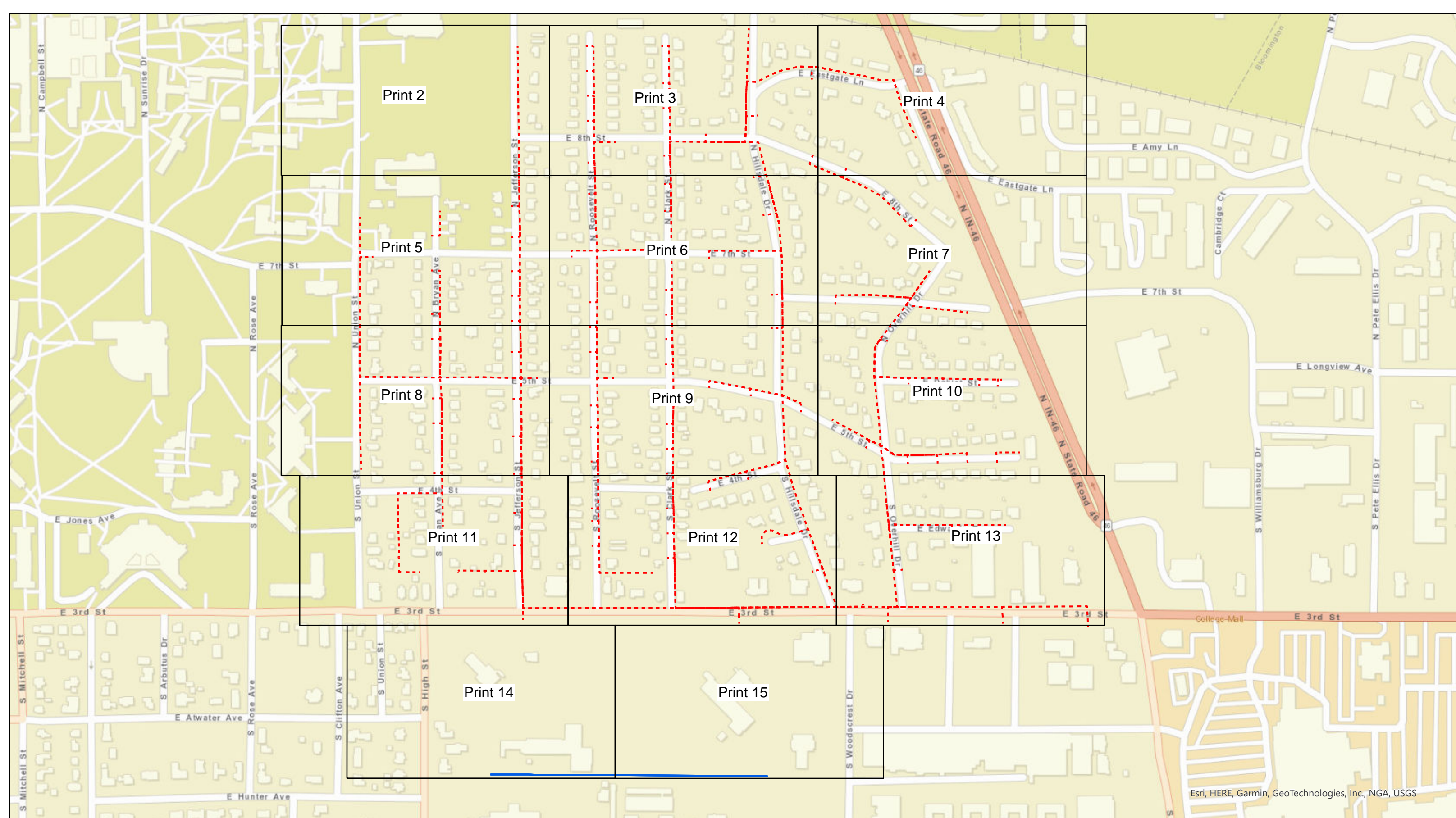

Legend E 3rd St

- - - Conduit
- FiberCable
- Grids



City of Bloomington, IN Permit:
Design View

INI	BY	DATE	DESCRIPTION



445 N
Union ST

1910 E
10TH ST

430 N
JEFFERSON ST

428 N
JEFFERSON ST

Flowerpot

426 N
JEFFERSON ST

73'

24x36x24

416 N
JEFFERSON ST

410 N
JEFFERSON ST

176'

Flowerpot

400 N
JEFFERSON ST

E 8th ST

192'

336 N
JEFFERSON ST

336 1/2 N
JEFFERSON ST

Flowerpot

326 N
JEFFERSON ST



324 N
JEFFERSON ST

435 N
Union ST

N Union ST

N Jefferson ST

Legend

-  Poles
-  Vaults
-  Overhead Strand
-  Conduit
-  Bloomington_Parcels
-  Risers
-  Address
-  Anchor



All Flowerpots 12" DIA



City of Bloomington, IN Permit:
Design View

INI	BY	DATE	DESCRIPTION

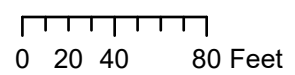

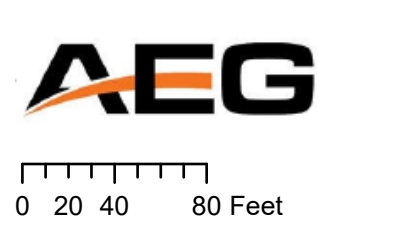
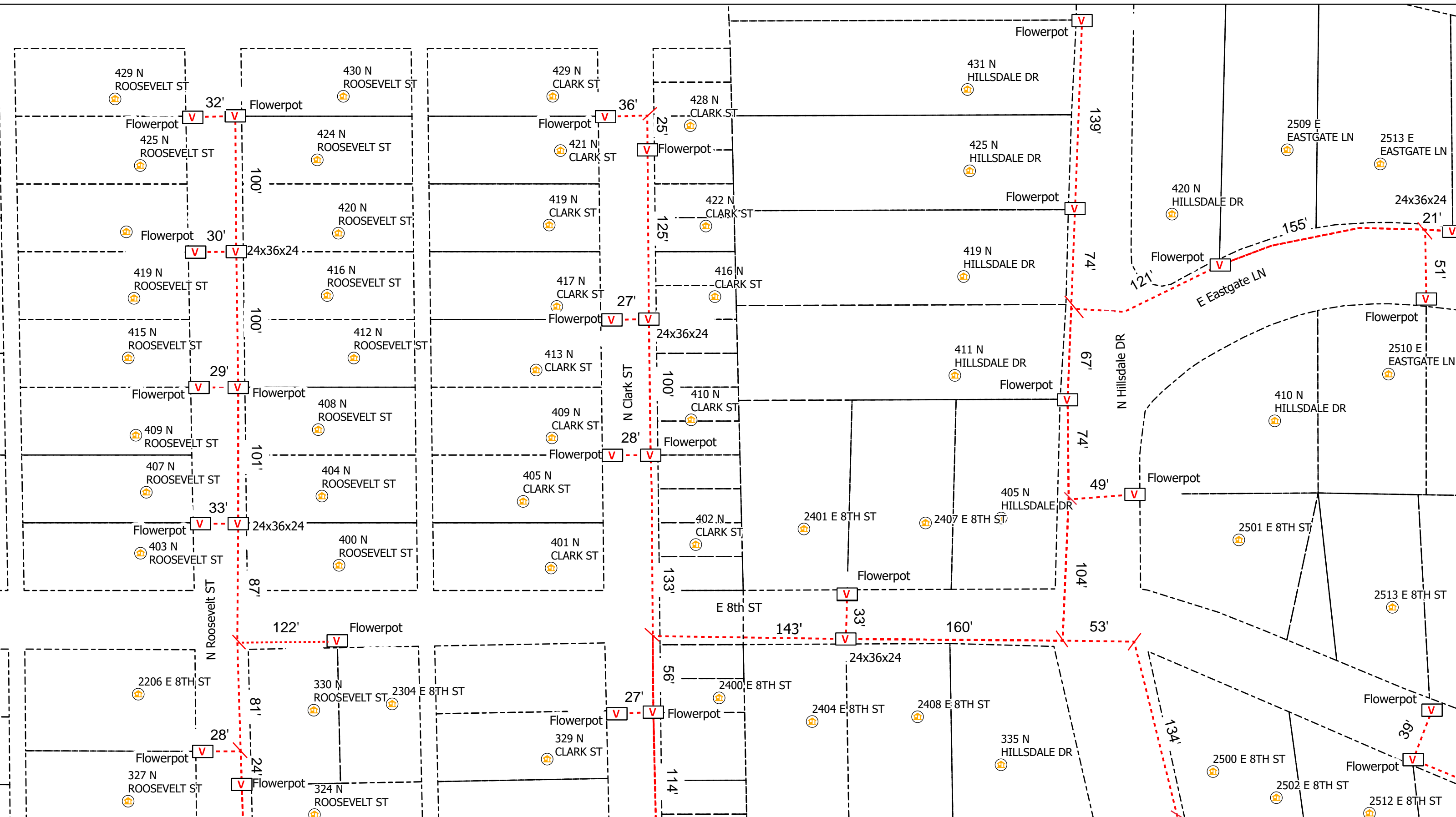

Legend

- Poles
- Risers
- Vaults
- Address
- Overhead Strand
- Conduit
- Anchor
- Sidewalk
- Bloomington_Parcels

All Flowerpots 12" DIA

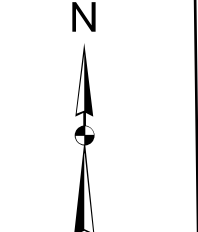

City of Bloomington, IN Permit:
Design View

INI	BY	DATE	DESCRIPTION

Print 3 of 15

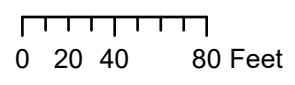
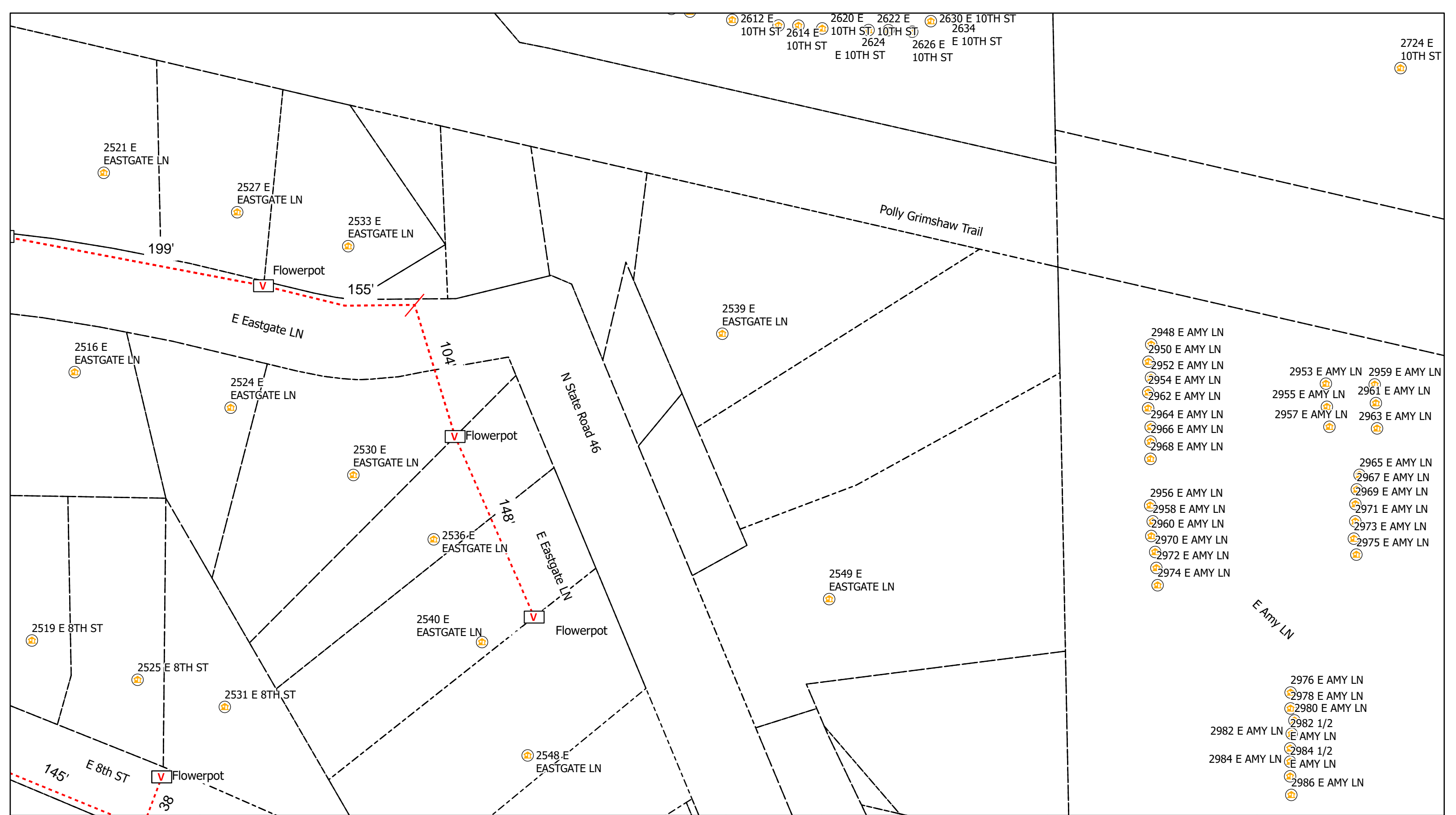

Legend

- Poles
- Vaults
- Overhead Strand
- Conduit
- Bloomington_Parcels
- Risers
- Address
- Anchor
- Sidewalk

All Flowerpots 12" DIA



City of Bloomington, IN Permit:
Design View

INI	BY	DATE	DESCRIPTION



- 2948 E AMY LN
- 2950 E AMY LN
- 2952 E AMY LN
- 2954 E AMY LN
- 2962 E AMY LN
- 2964 E AMY LN
- 2966 E AMY LN
- 2968 E AMY LN
- 2953 E AMY LN
- 2955 E AMY LN
- 2957 E AMY LN
- 2959 E AMY LN
- 2961 E AMY LN
- 2963 E AMY LN
- 2965 E AMY LN
- 2967 E AMY LN
- 2969 E AMY LN
- 2971 E AMY LN
- 2973 E AMY LN
- 2975 E AMY LN
- 2956 E AMY LN
- 2958 E AMY LN
- 2960 E AMY LN
- 2970 E AMY LN
- 2972 E AMY LN
- 2974 E AMY LN
- 2976 E AMY LN
- 2978 E AMY LN
- 2980 E AMY LN
- 2982 1/2 E AMY LN
- 2984 1/2 E AMY LN
- 2986 E AMY LN
- 2982 E AMY LN
- 2984 E AMY LN

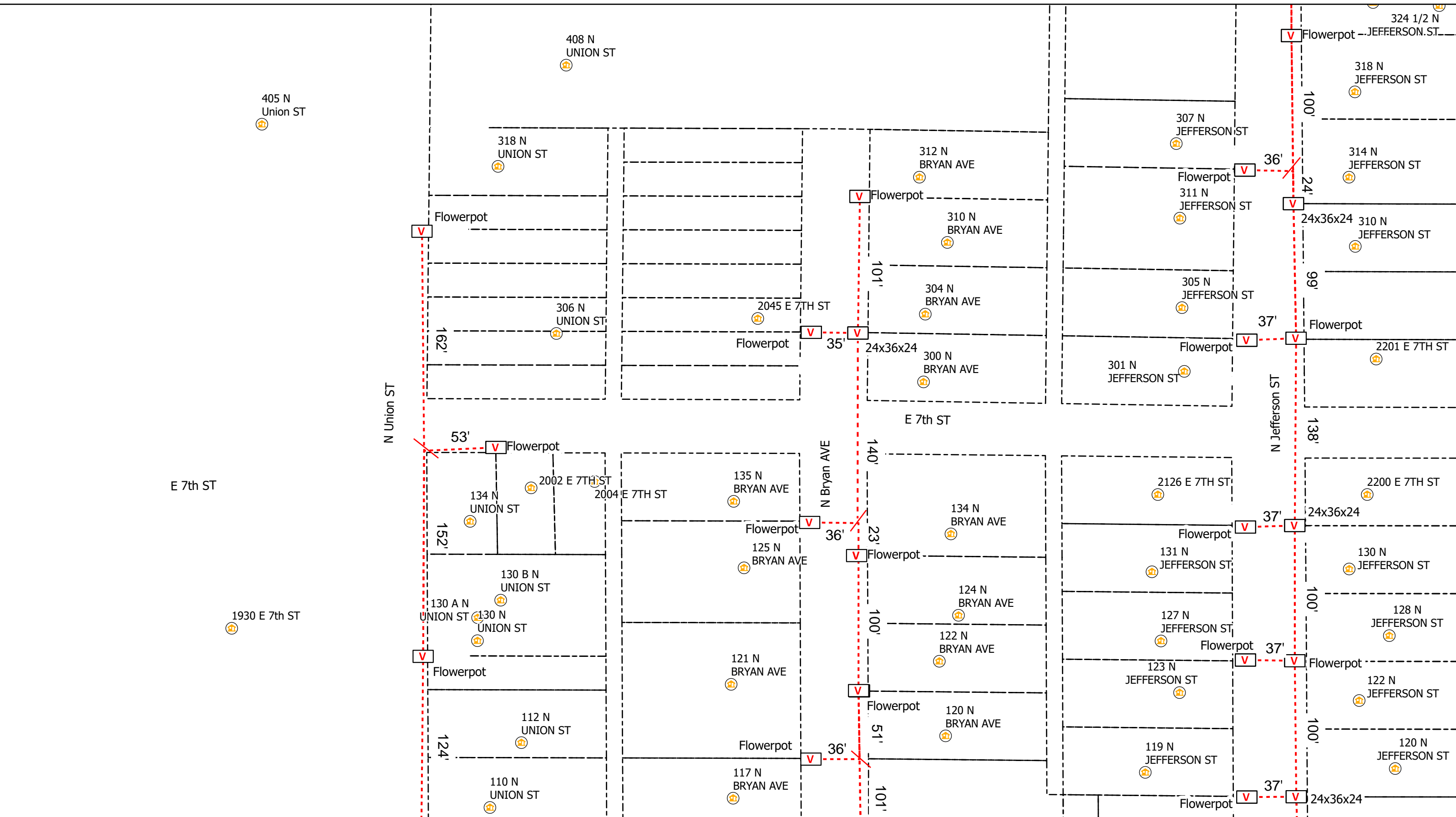

AEG

0 20 40 80 Feet

Legend

- Poles
- Vaults
- Overhead Strand
- Conduit
- Bloomington_Parcels
- Risers
- Address
- Anchor
- Sidewalk

All Flowerpots 12" DIA

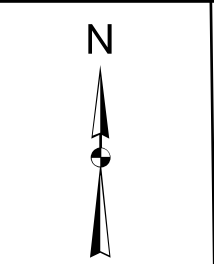

City of Bloomington, IN Permit:
Design View

INI	BY	DATE	DESCRIPTION

Print 5 of 15

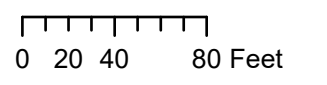
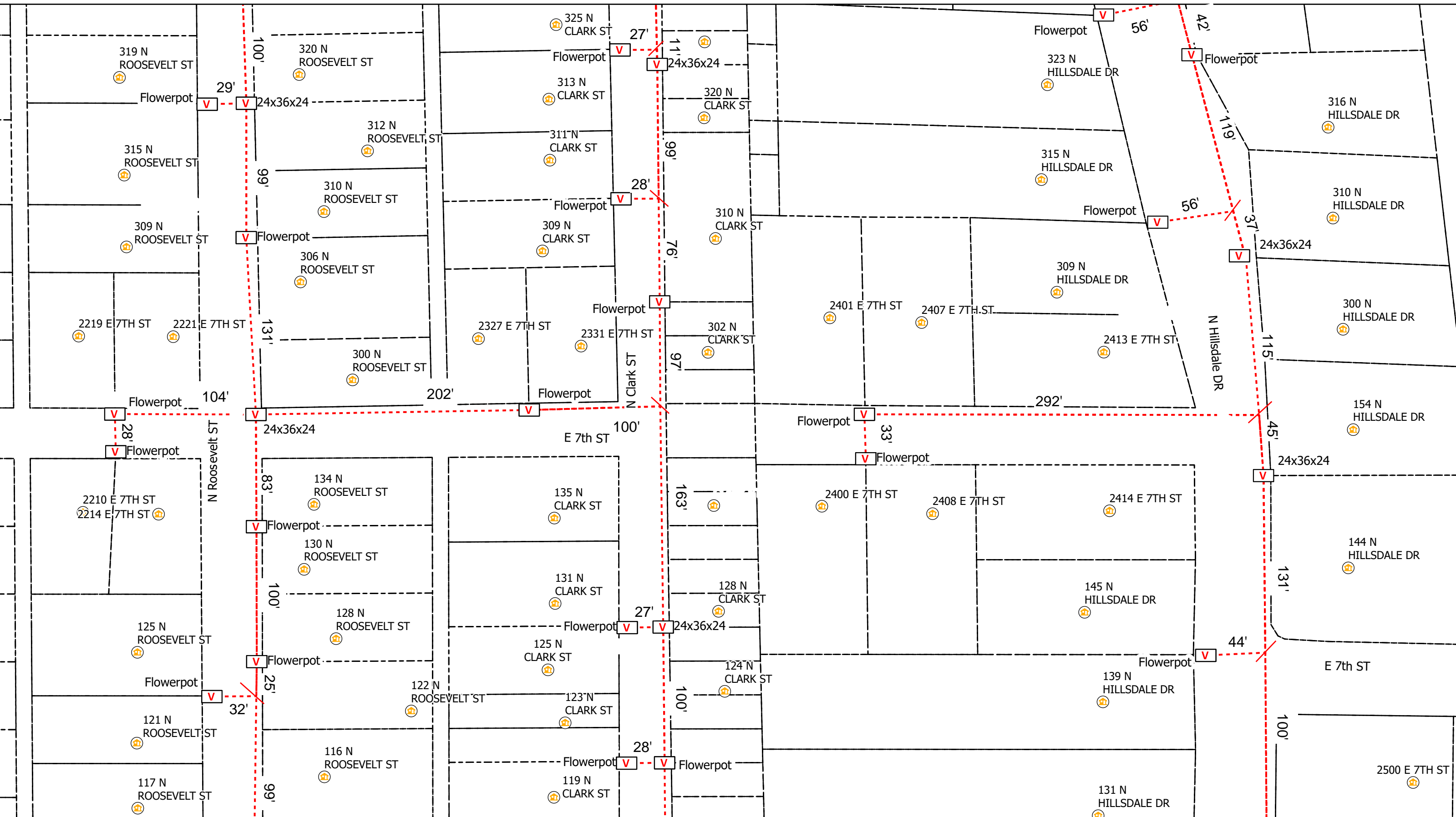

Legend

- Poles
- Vaults
- Overhead Strand
- Conduit
- Bloomington_Parcels
- Risers
- Address
- Anchor
- Sidewalk

All Flowerpots 12" DIA



City of Bloomington, IN Permit:
Design View

INI	BY	DATE	DESCRIPTION



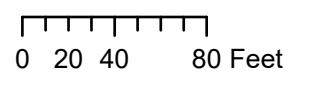
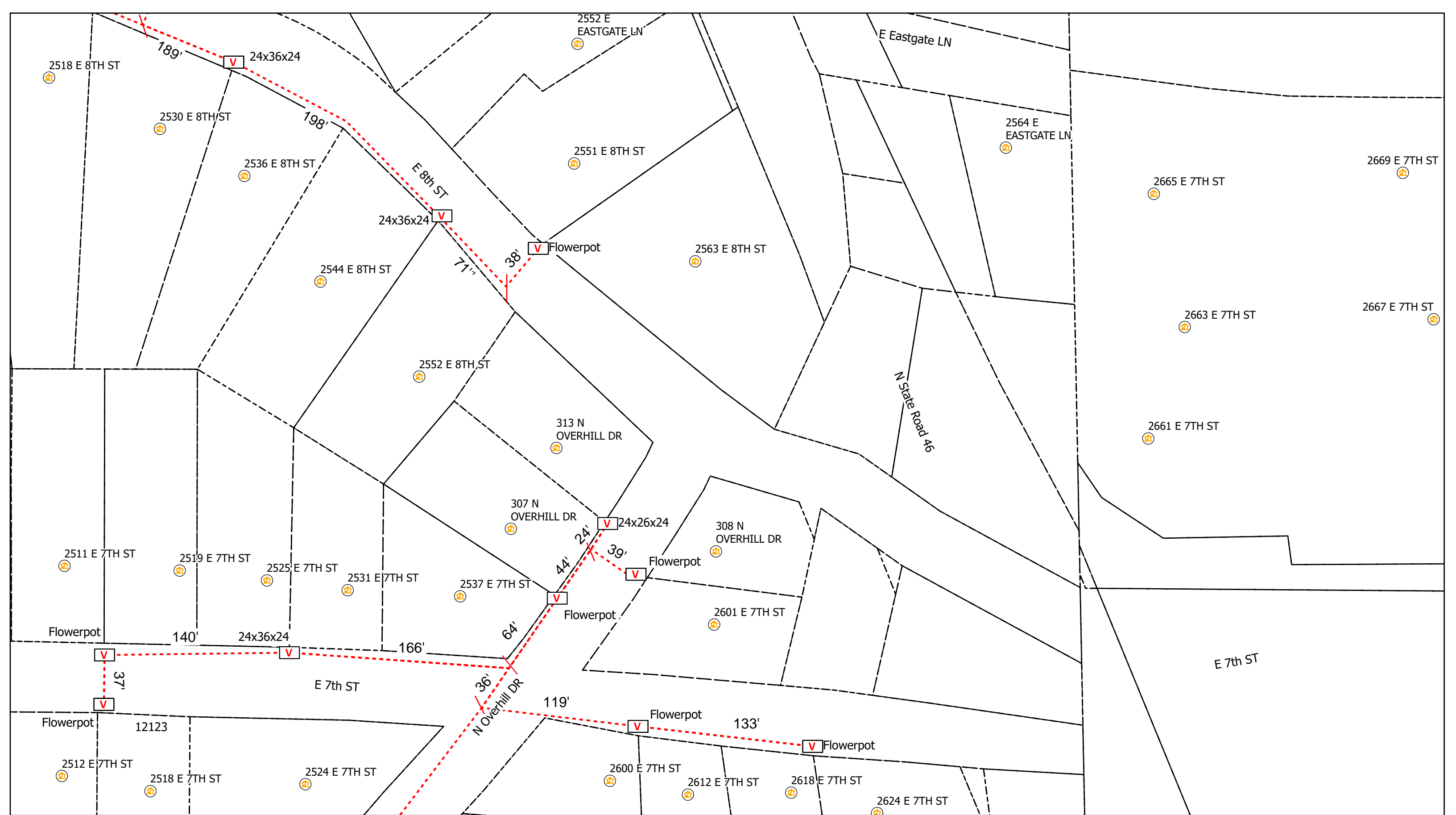

Legend

- Poles
- Vaults
- Overhead Strand
- Conduit
- Bloomington_Parcels
- Risers
- Address
- Anchor
- Sidewalk

All Flowerpots 12" DIA



City of Bloomington, IN Permit:
Design View

INI	BY	DATE	DESCRIPTION



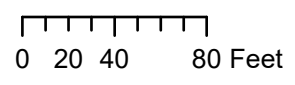
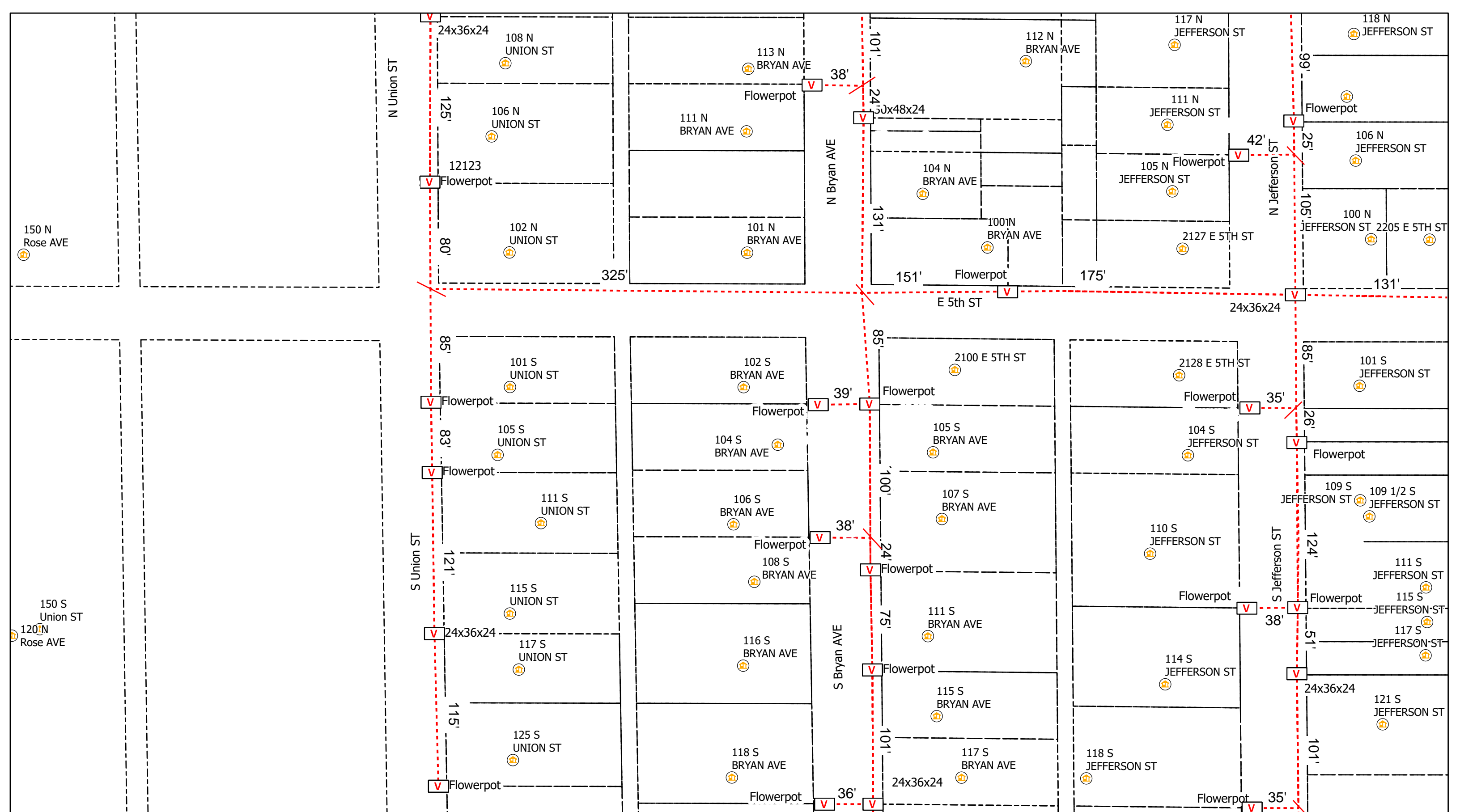

Legend

- Poles
- Vaults
- Overhead Strand
- Conduit
- Bloomington_Parcels
- Risers
- Address
- Anchor
- Sidewalk

All Flowerpots 12" DIA



City of Bloomington, IN Permit:
Design View

INI	BY	DATE	DESCRIPTION



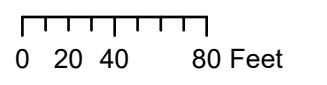
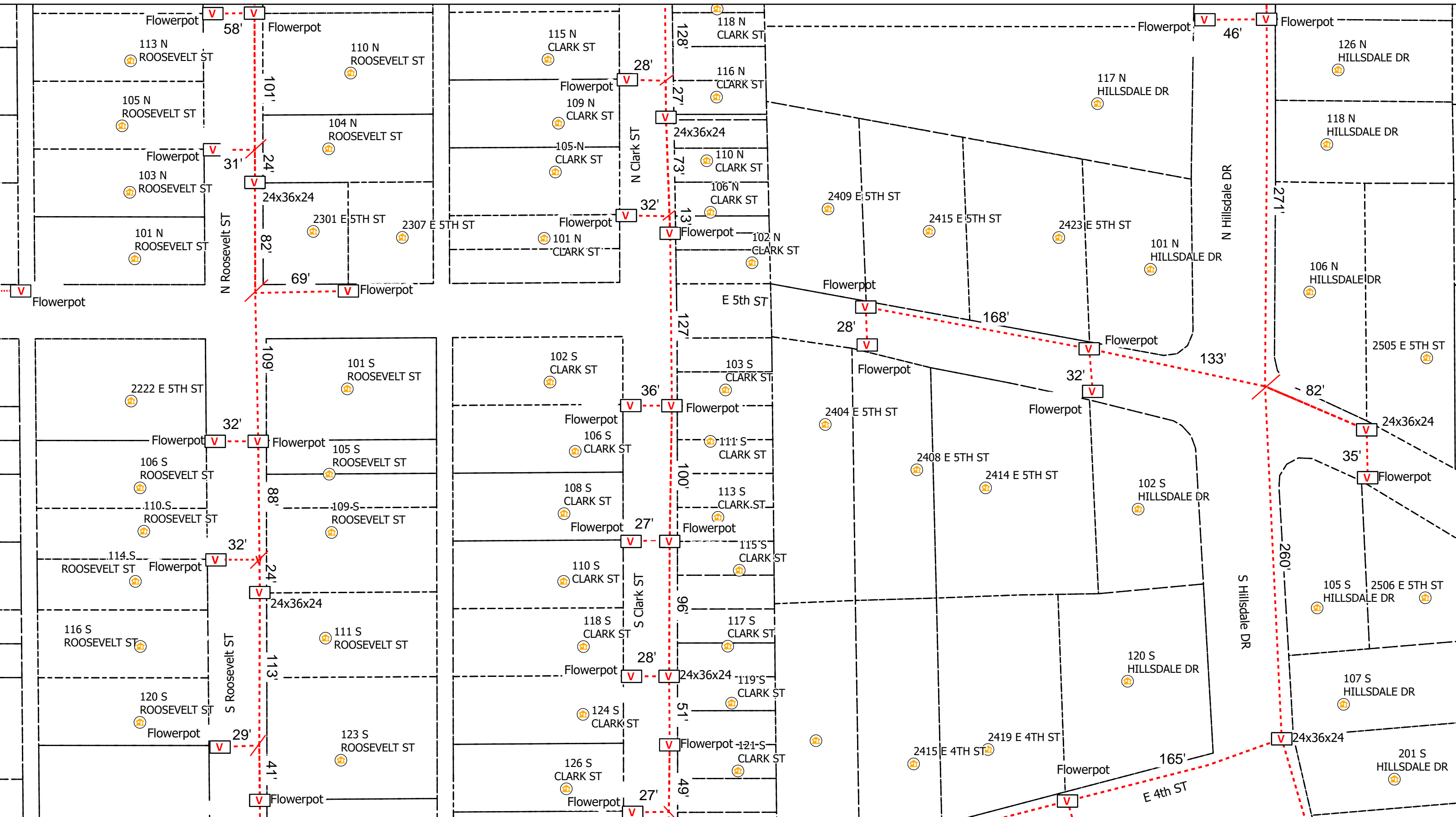

Legend

- Poles
- Vaults
- Overhead Strand
- Conduit
- Bloomington_Parcels
- Risers
- Address
- Anchor
- Sidewalk

All Flowerpots 12" DIA



City of Bloomington, IN Permit:
Design View

INI	BY	DATE	DESCRIPTION



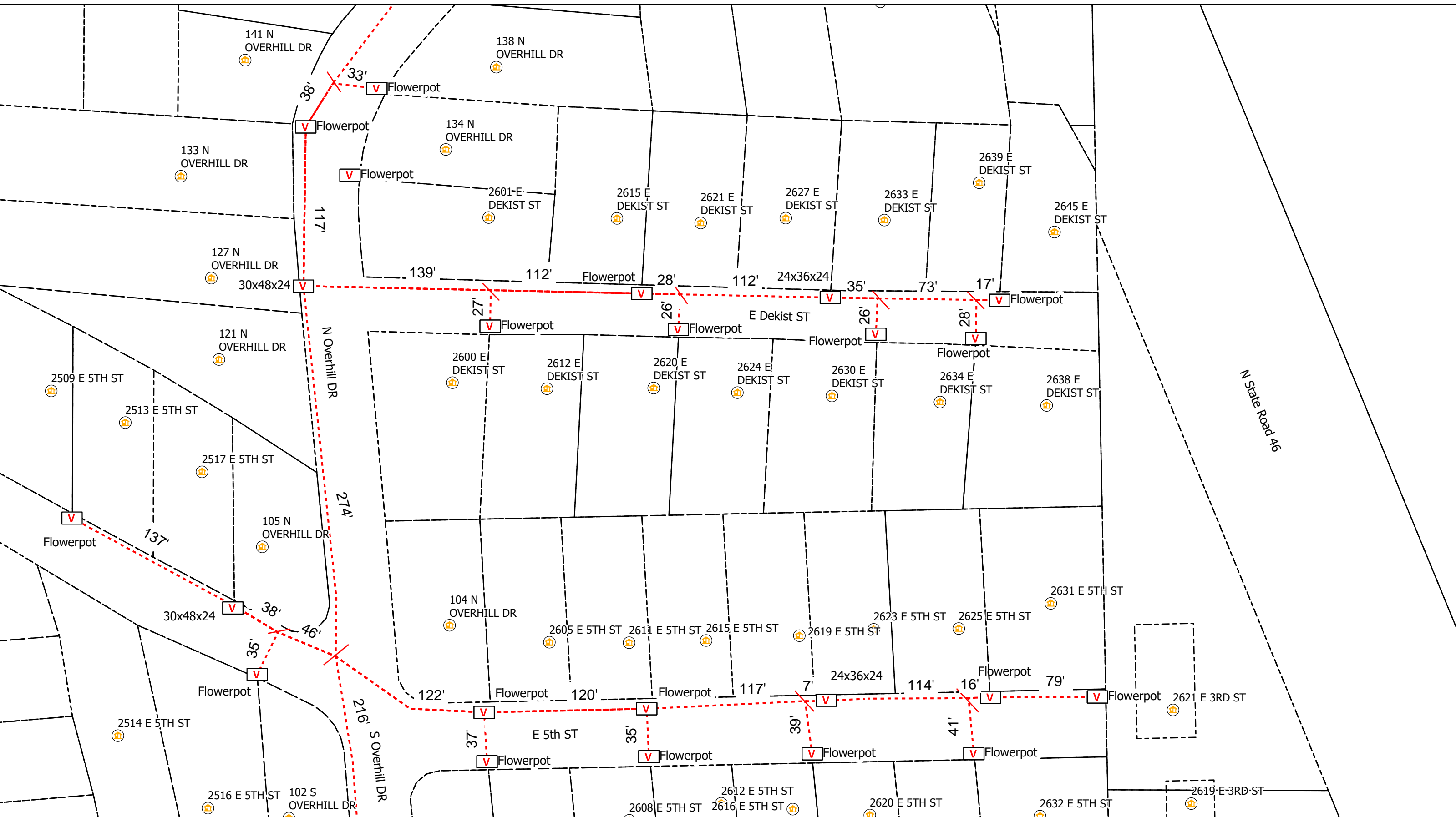

0 20 40 80 Feet

Legend

- Poles
- V Vaults
- Overhead Strand
- Conduit
- Bloomington_Parcels
- R Risers
- A Address
- Y Anchor
- K Sidewalk

All Flowerpots 12" DIA



City of Bloomington, IN Permit:
Design View

INI	BY	DATE	DESCRIPTION



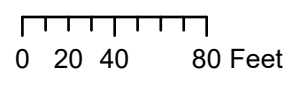
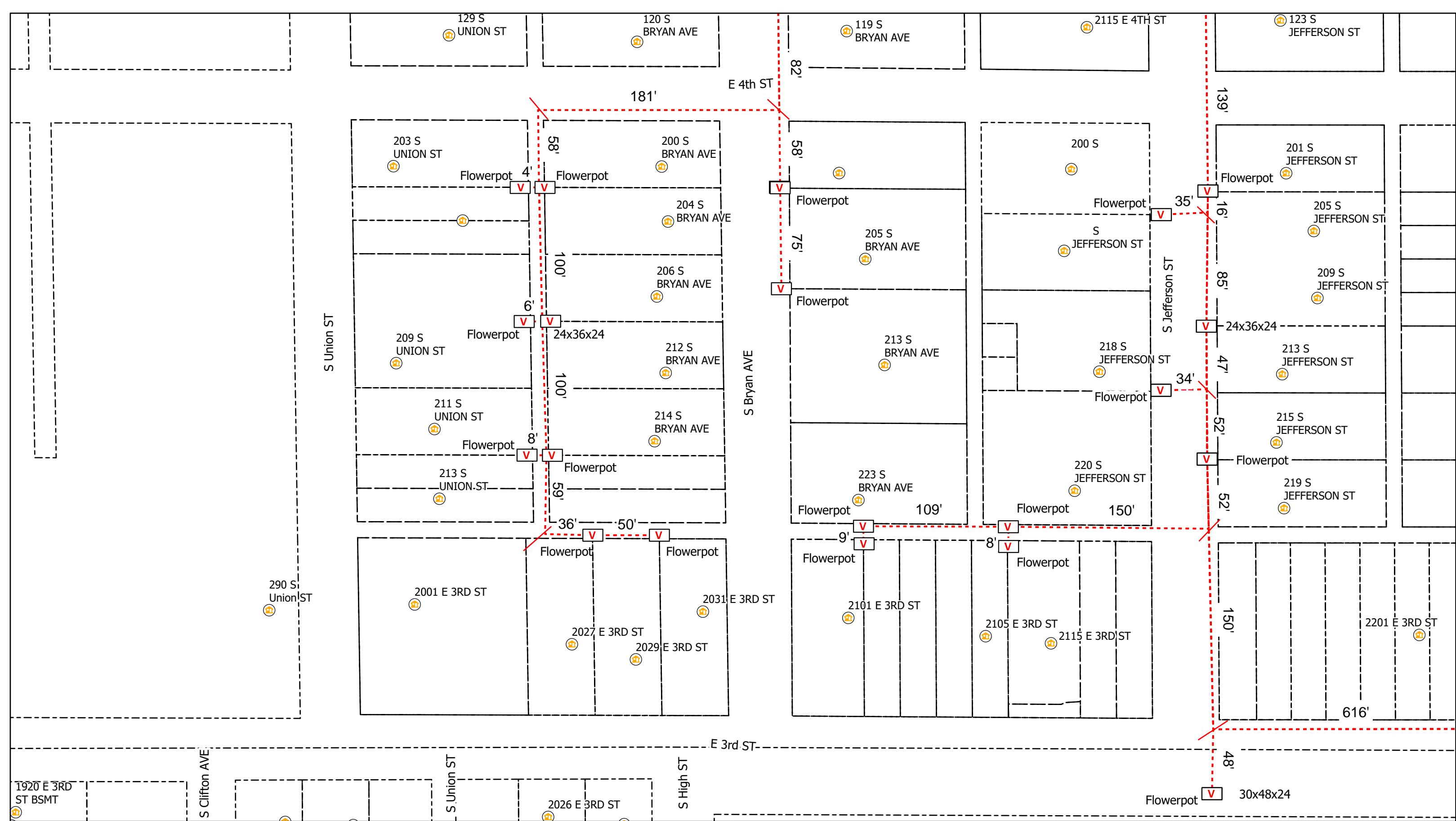

Legend

- Poles
- Vaults
- Overhead Strand
- Conduit
- Bloomington_Parcels
- Risers
- Address
- Anchor
- Sidewalk

All Flowerpots 12" DIA



City of Bloomington, IN Permit:
Design View

INI	BY	DATE	DESCRIPTION



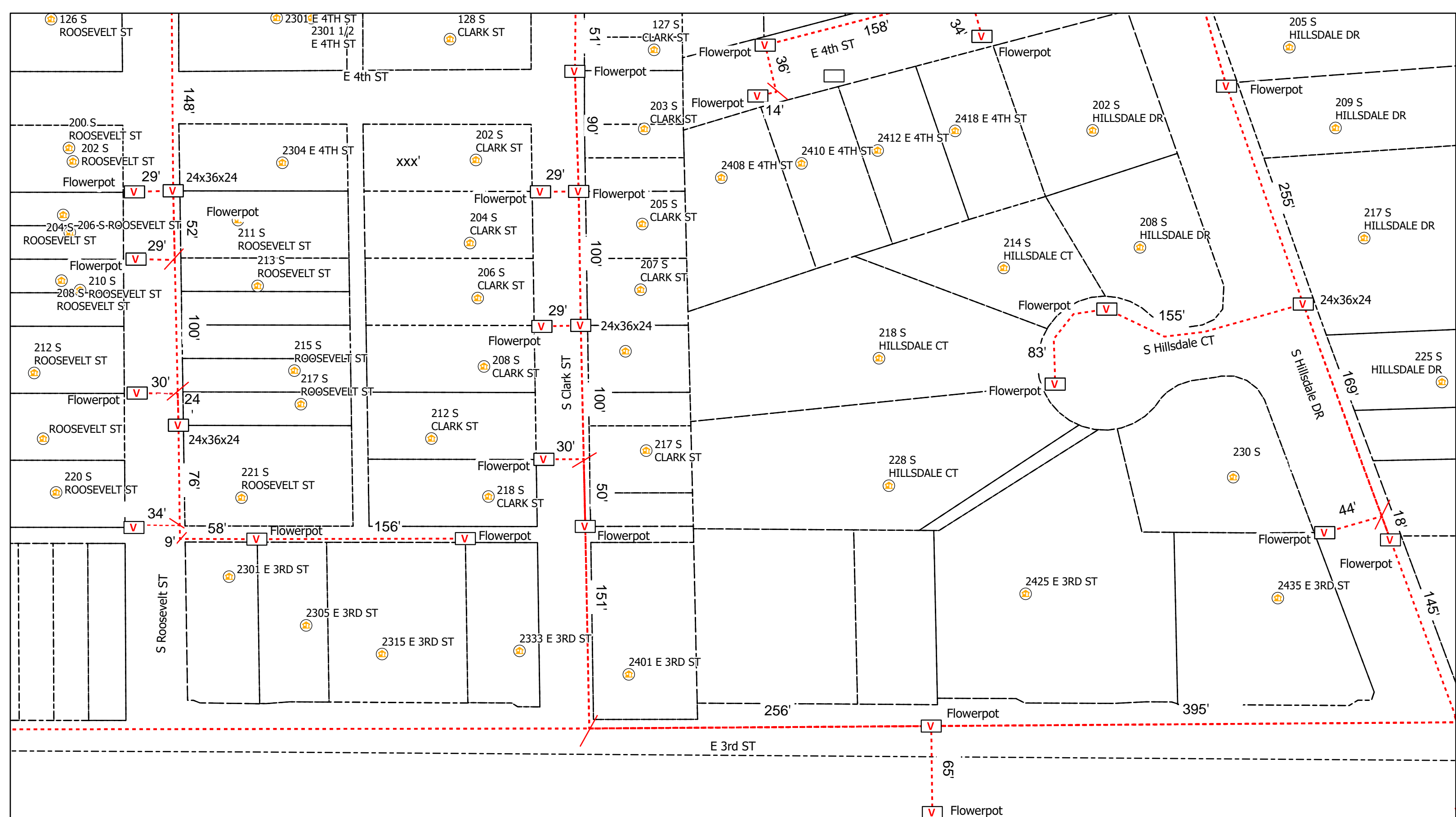

Legend

- Poles
- Vaults
- Overhead Strand
- Conduit
- Bloomington_Parcels
- Risers
- Address
- Anchor
- Sidewalk

All Flowerpots 12" DIA

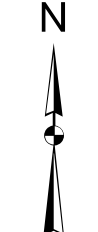

City of Bloomington, IN Permit:
Design View

INI	BY	DATE	DESCRIPTION

Print 12 of 15

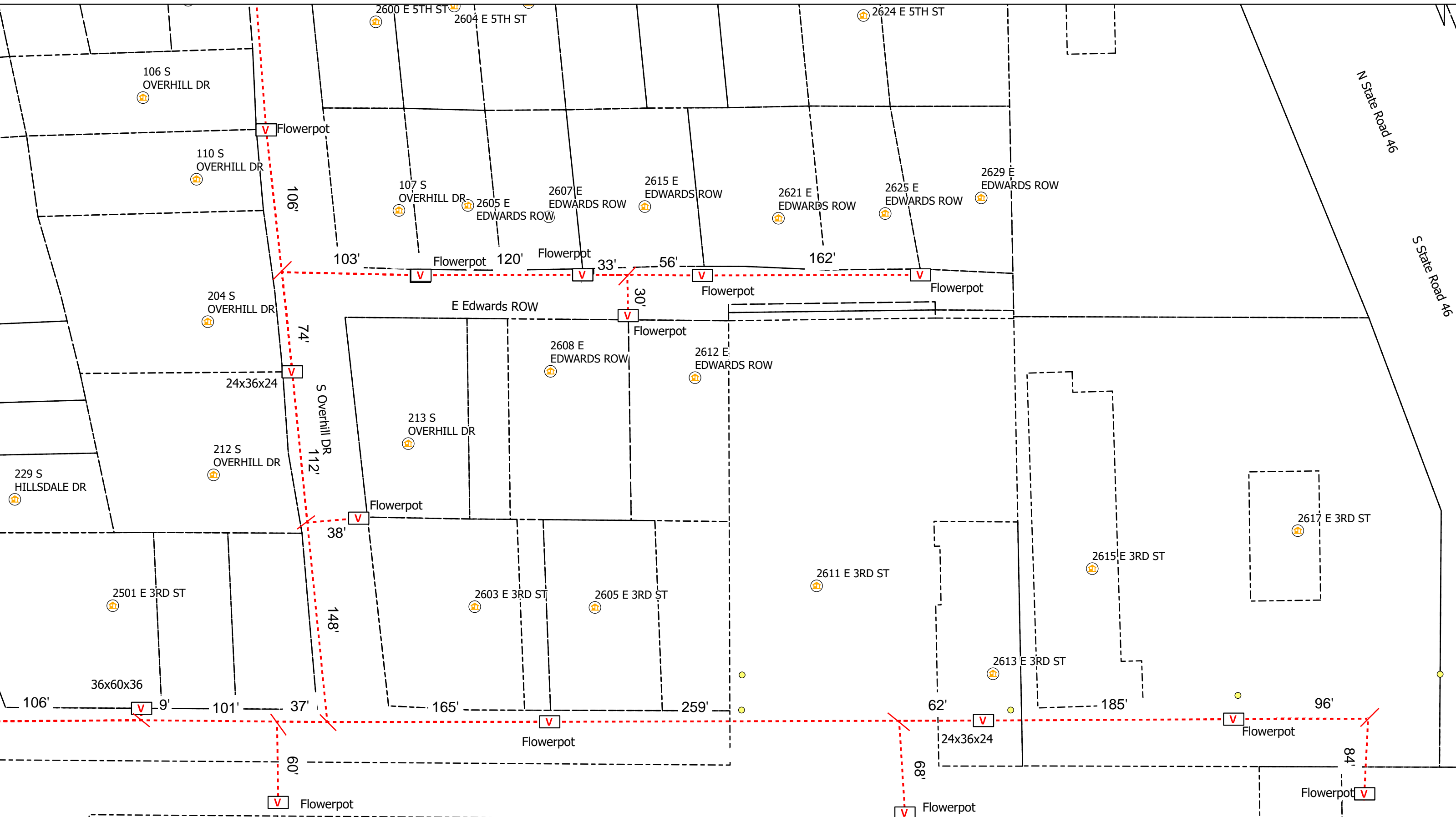

AEG

0 20 40 80 Feet

Legend

- Poles
- Risers
- Vaults
- Overhead Strand
- Conduit
- Bloomington_Parcels
- Address
- Anchor
- Sidewalk

All Flowerpots 12" DIA

City of Bloomington, IN Permit:
Design View

INI	BY	DATE	DESCRIPTION

Print 13 of 15

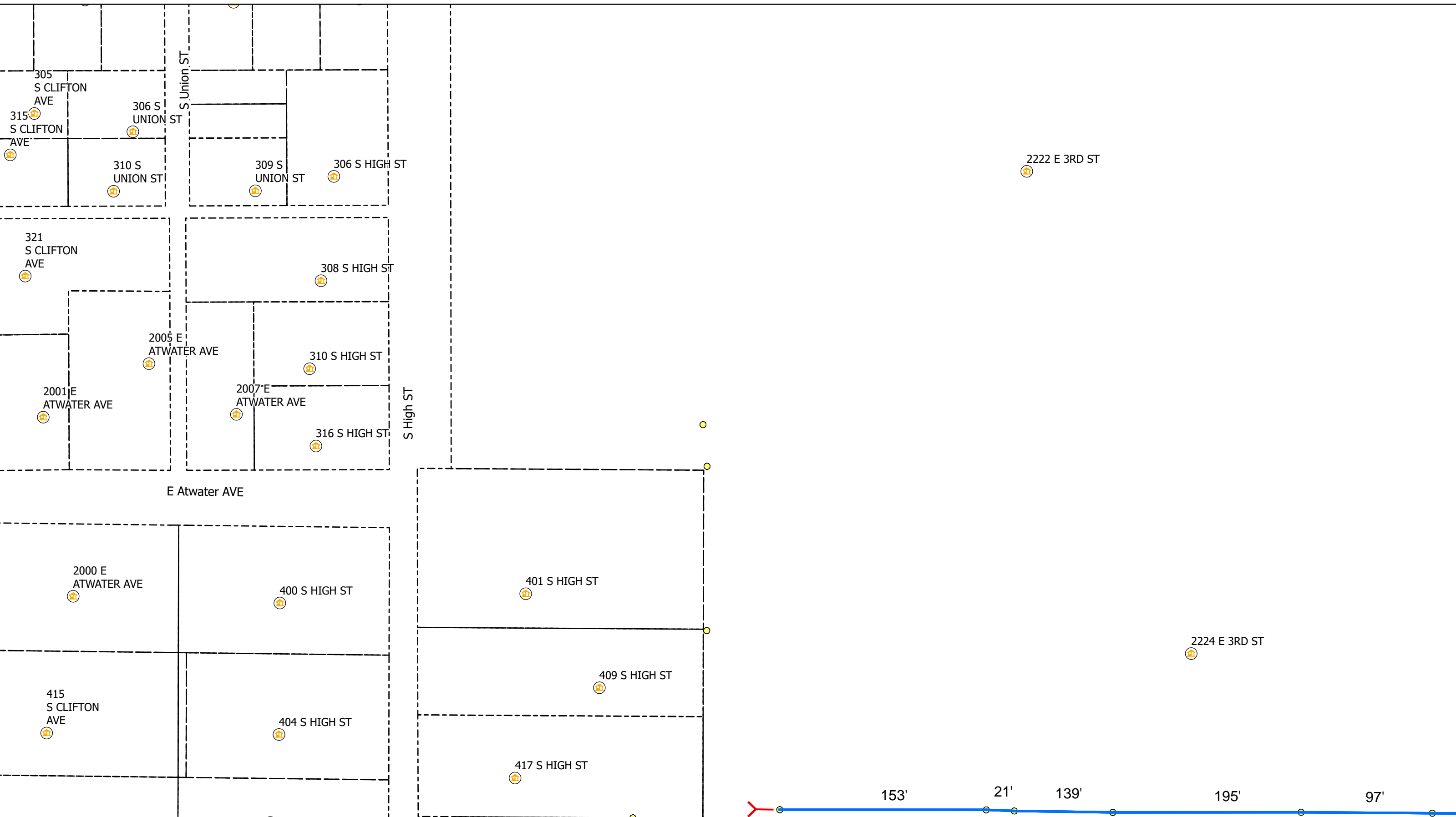

0 20 40 80 Feet

Legend

- Poles
- Vaults
- Overhead Strand
- Conduit
- Bloomington_Parcels
- Risers
- Address
- Anchor
- Sidewalk

All Flowerpots 12" DIA

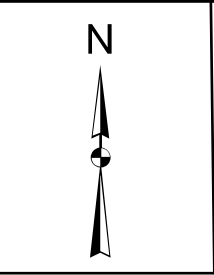

City of Bloomington, IN Permit:
Design View

INI	BY	DATE	DESCRIPTION

Print 14 of 15

2500 E 3RD ST

322 S
WOODSCREST DR

324 S
WOODSCREST DR

326 S
WOODSCREST DR

328 S
WOODSCREST DR

320 S
WOODSCREST DR

2420 E 3RD ST

410 S
WOODSCREST DR

2504 E 3RD ST
2510 E 3RD ST
2506 E 3RD ST

411 S
WOODSCREST DR

S Woodcrest DR

98'







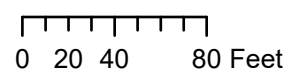

194'

189'

150'



Legend

-  Poles
-  Vaults
-  Overhead Strand
-  Conduit
-  Bloomington_Parcels
-  Risers
-  Address
-  Anchor
-  Sidewalk

All Flowerpots 12" DIA



City of Bloomington, IN Permit:
Design View

INI	BY	DATE	DESCRIPTION



CONCEPTUAL SIDE VIEW

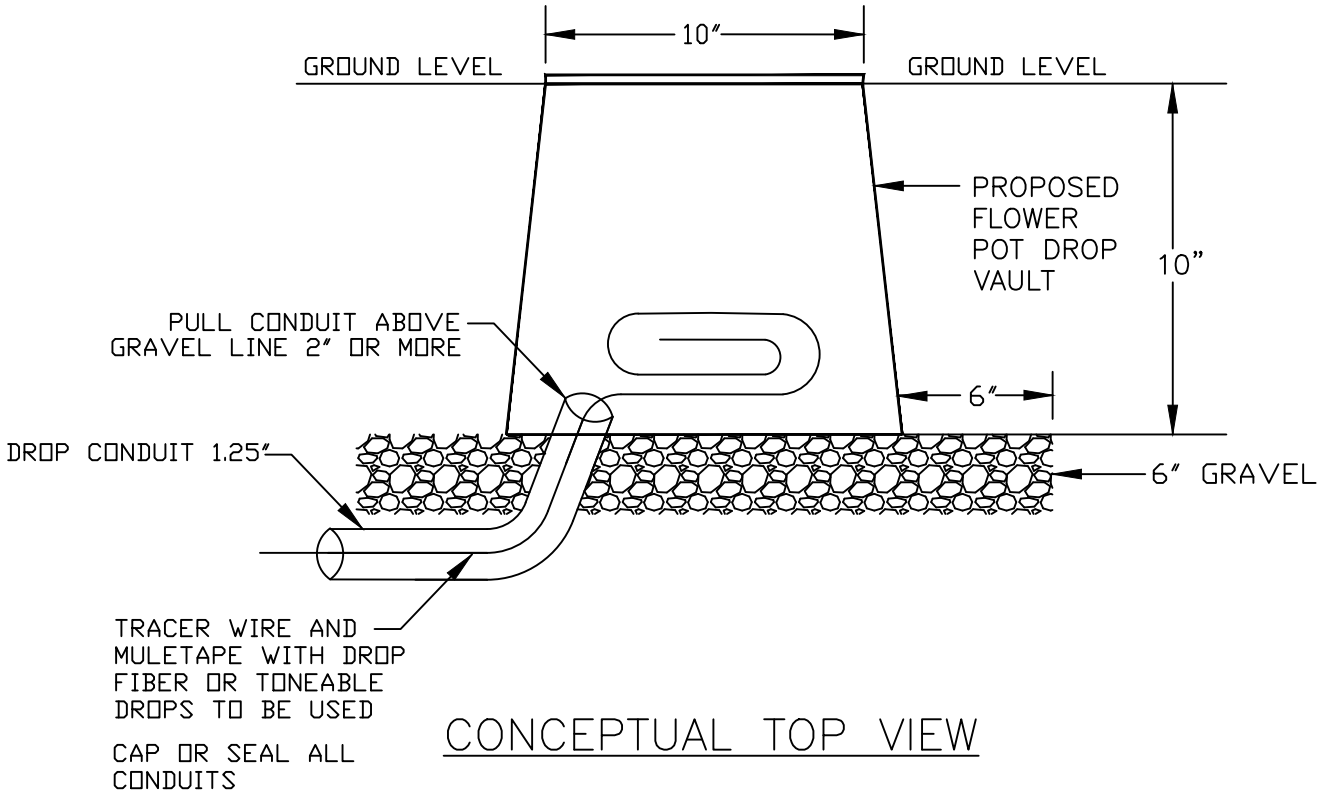

CONCEPTUAL TOP VIEW

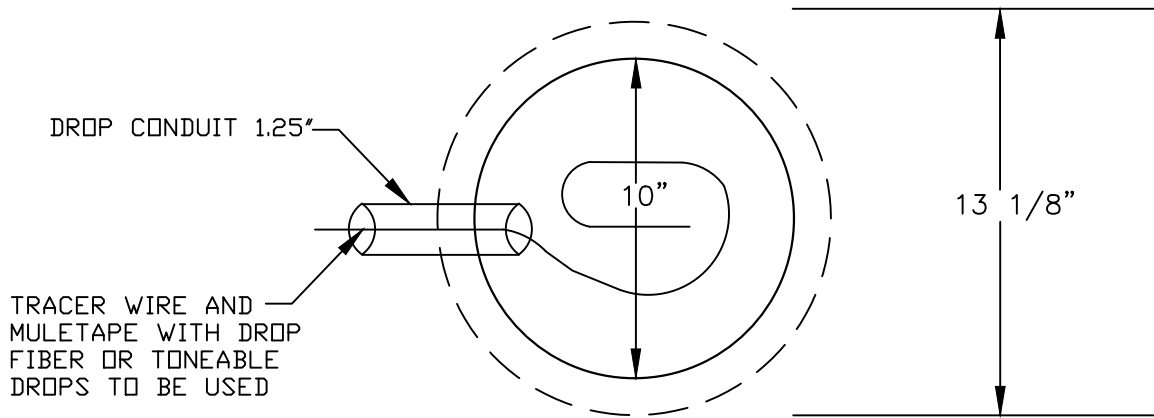

FLOWER POT

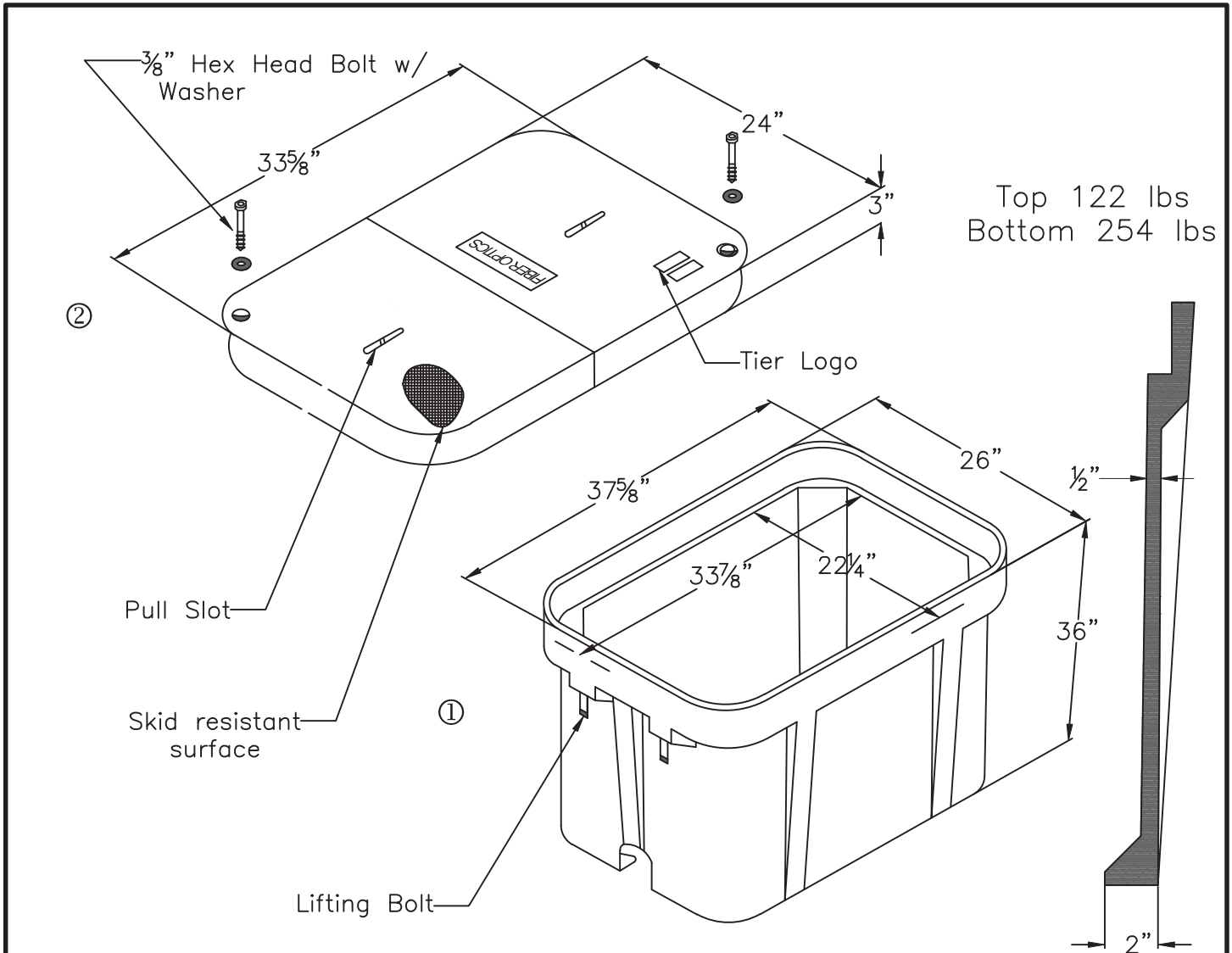

NOTES:

1. Enclosure to be drilled as needed for duct entry.
2. After setting enclosure, fill bottom with #33 pea gravel to approx. depth of 2" (approx. 1.0 cu ft of gravel).
3. Conduits/cables shall be individually tagged to indicate where the other end of the conduit is next accessible.

ITEM	MATERIAL ID	MATERIAL	QTY	ASSET ID
①	23223669	Enclosure Grade Level, 24" x 36", 36" depth, TIER 22 Rating	1	✓397100004
②	23223670	Top, two-piece split, 24" x 36", TIER 15 Rating	1	
		#33 Pea Gravel	As Req'd	

<p>DESIGN PARAMETERS: Enclosures utilized for both cable pulling access, cable storage, and splice case storage.</p> <p>Enclosures will typically be installed every 500 to 1000 feet as necessitated by system design.</p>	ENCLOSURE, GRADE-LEVEL, TIER 15 24"X 36" – 36" DEPTH		
		Revision Date:	Jul 2020
	RUS REF.	FIBER UTILITY NETWORK	REC
	N/A		UFOF1.3

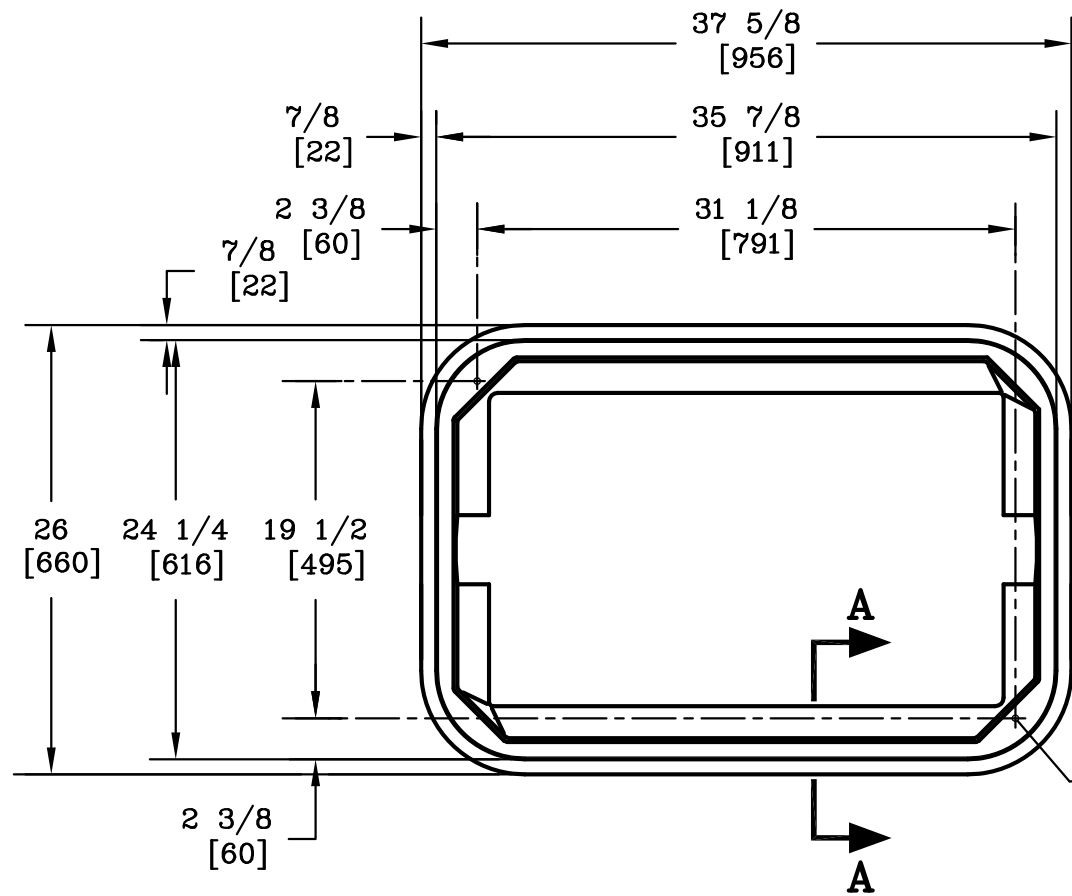

3/8-7 SELF ALIGNING,
REPLACEABLE S.S. EZ-NUT
2 PLACES

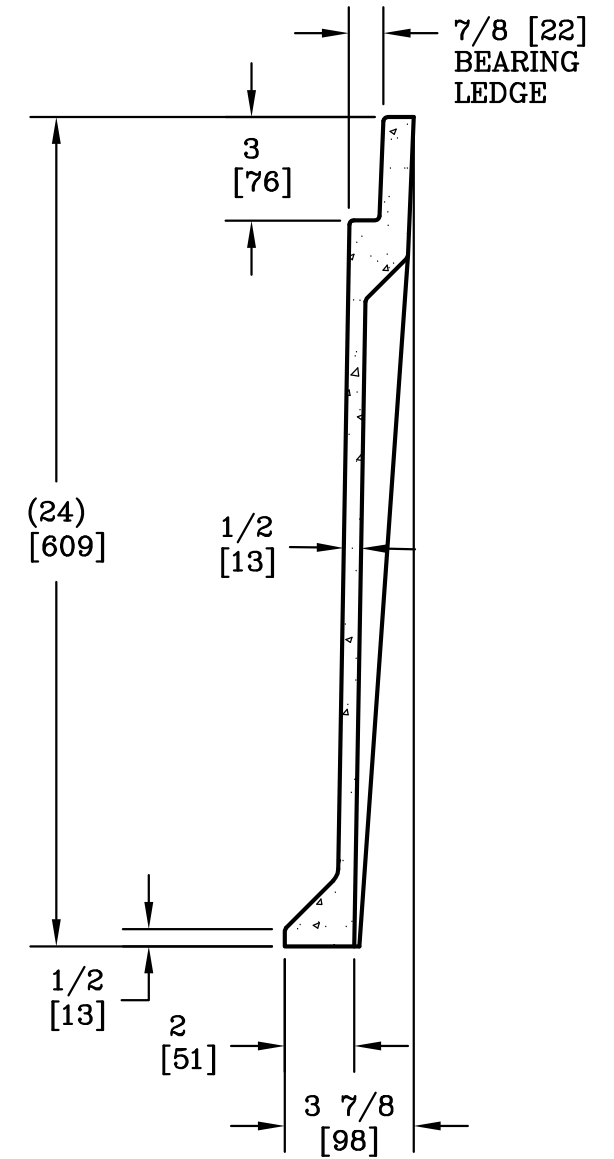
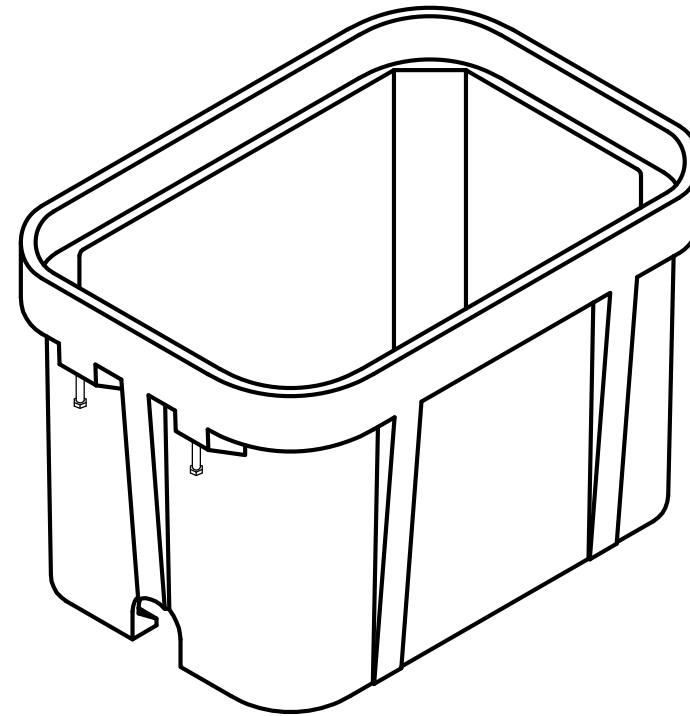

SECTION A-A
SCALE: 6"=1'

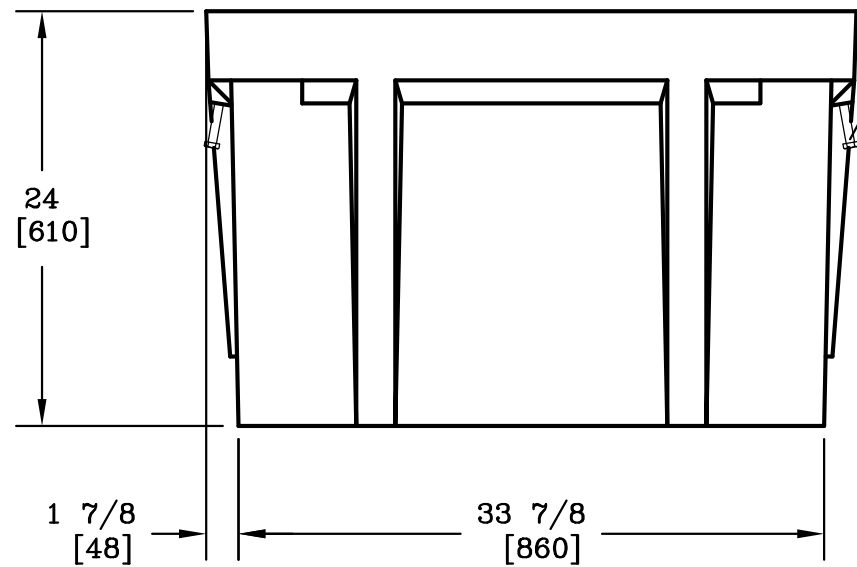

1/2-13
LIFTING BOLT
4 PLACES

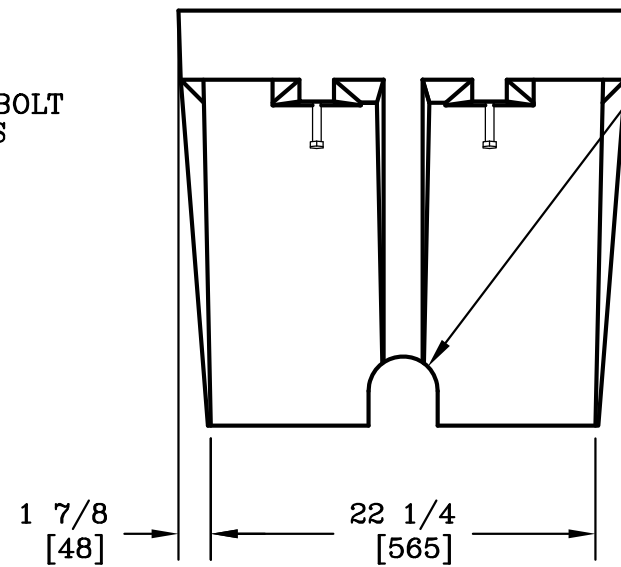

2X 4 [102] X 4 [102]
MOUSEHOLE (1 EACH END)

NOTE:

1. DIMENSIONS IN BRACKETS ARE IN MILLIMETERS UNLESS NOTED OTHERWISE.



DIMENSIONS ARE IN INCHES OR MILLIMETERS IN BRACKETS UNLESS OTHERWISE NOTED.					
DRN	BY	DATE	WEIGHT	3621 INDUSTRIAL PARK DR LENOIR CITY, TN 37771 800-346-3062 www.quazite.com	LOC
CHK	ENG	APR	181# 82kg		S
APR	APR	APR	SCALE	DRAWING DESCRIPTION	REV
			1"=1'		F
			SIZE	QUAZITE® BOX	3/12
			B		
PROJECT NUMBER				DRAWING NUMBER	
93641				PG2436BB24	
SHEET 1 OF 1					

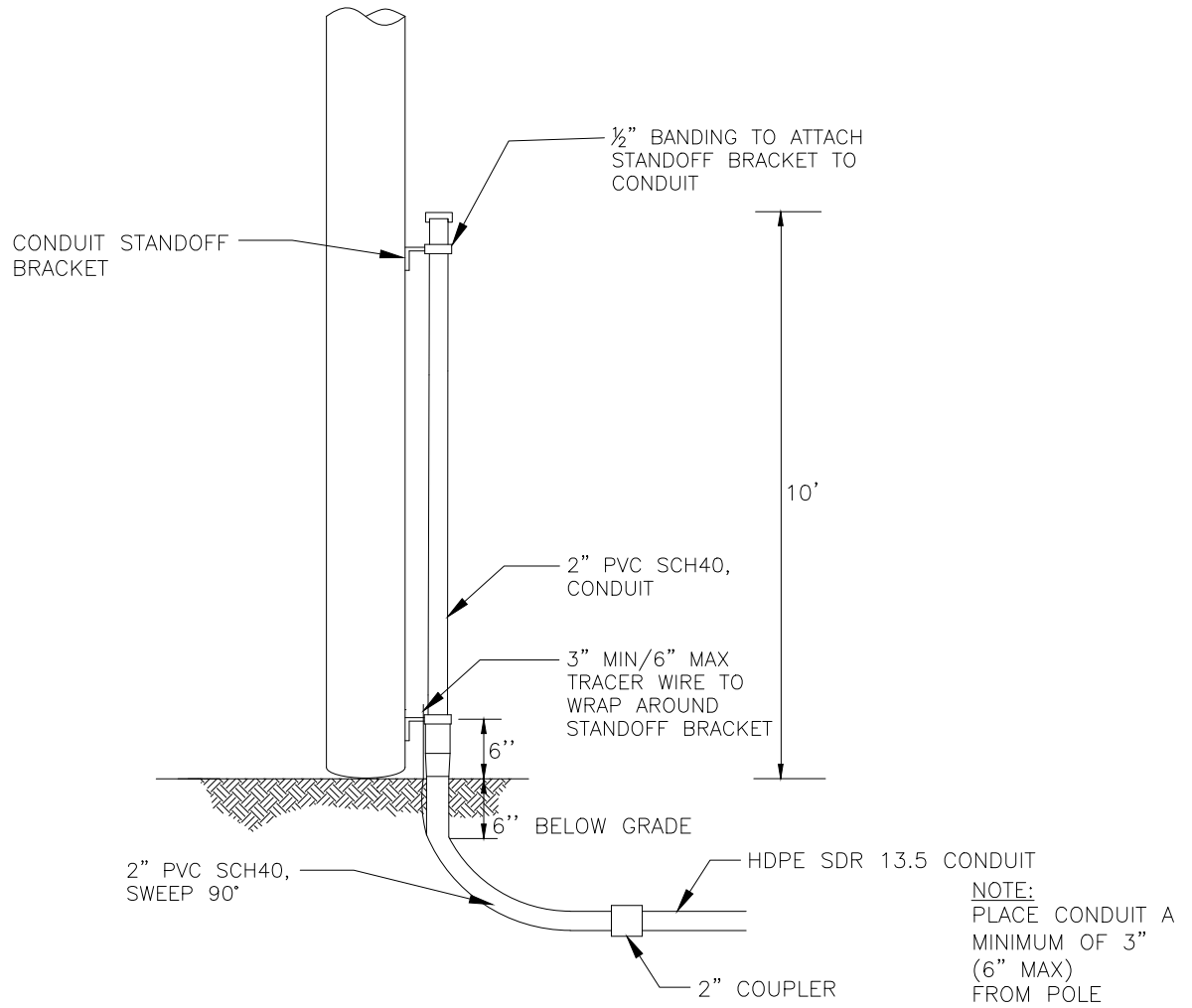

DESCRIPTION

QTY

MANUFACTURER
(PREFERRED)

PART #

SCREW, LAG, 1/2" x 4-1/2"	10		
HDPE SDR 13.5 CONDUIT, VARIOUS SIZES	N/A		
2" PVC SCH40, RISER PIPE	1		
#12 TRACER WIRE	N/A		
2" PVC SCH40, SWEEP, 90 DEG	1		
CONDUIT STANDOFF BRACKET	VARIES		
CONDUIT STRAP KIT	VARIES		
2" COUPLER	1		



TYPICAL RISER
CONDUIT
WOOD POLE

(R2-W)

Spacing Charts Based on MUTCD			Must be Approved by an Engineer				
Speed (MPH) Prior To Road Work	SIGN SPACING, FT.		BUFFER SPACE, FT.	TAPER LENGTH, FT.		CHANNELIZING SPACING, FT.	
	Non-Divided Highways	Divided Highways	Length	Shoulder (10 ft. Width)	Lane (12 ft. Width)	Through Taper	Through Buffer/Work Area
0-35	200	200	250	70	245	35	50
40-45	350	500	360	150	540	40	80
50-55	500	1000	495	185	660	50	100
60-70	SA-1000, SB-1500, SC-2640		730	235	840	60	120
Urban Low Speed - 100 FT							

APPROVED/ACCEPTED BY:
ENGINEER, OWNER, or PRIME CONTRACTOR
 Check for Notice to Proceed.
BLC01b-F22 - E 3rd St - TCP1

Signature: _____

Company: _____

Road Runner
Safety Services, Inc.

Date: 9/23/2022 Project: BLC01b-F22 - E 3rd St - TCP1 :
: Traffic Control Suggestion For: AEG :
By: Road Runner Safety Services, Inc. : Nathan

Comments:
Drawing not to scale. Traffic control plan must be approved by an engineer. This is a suggestion only. Road Runners Safety Services, Inc. has no liability for this suggested traffic control plan. Actual placement and spacing of all traffic control devices will depend on field conditions and must conform to MUTCD standards.

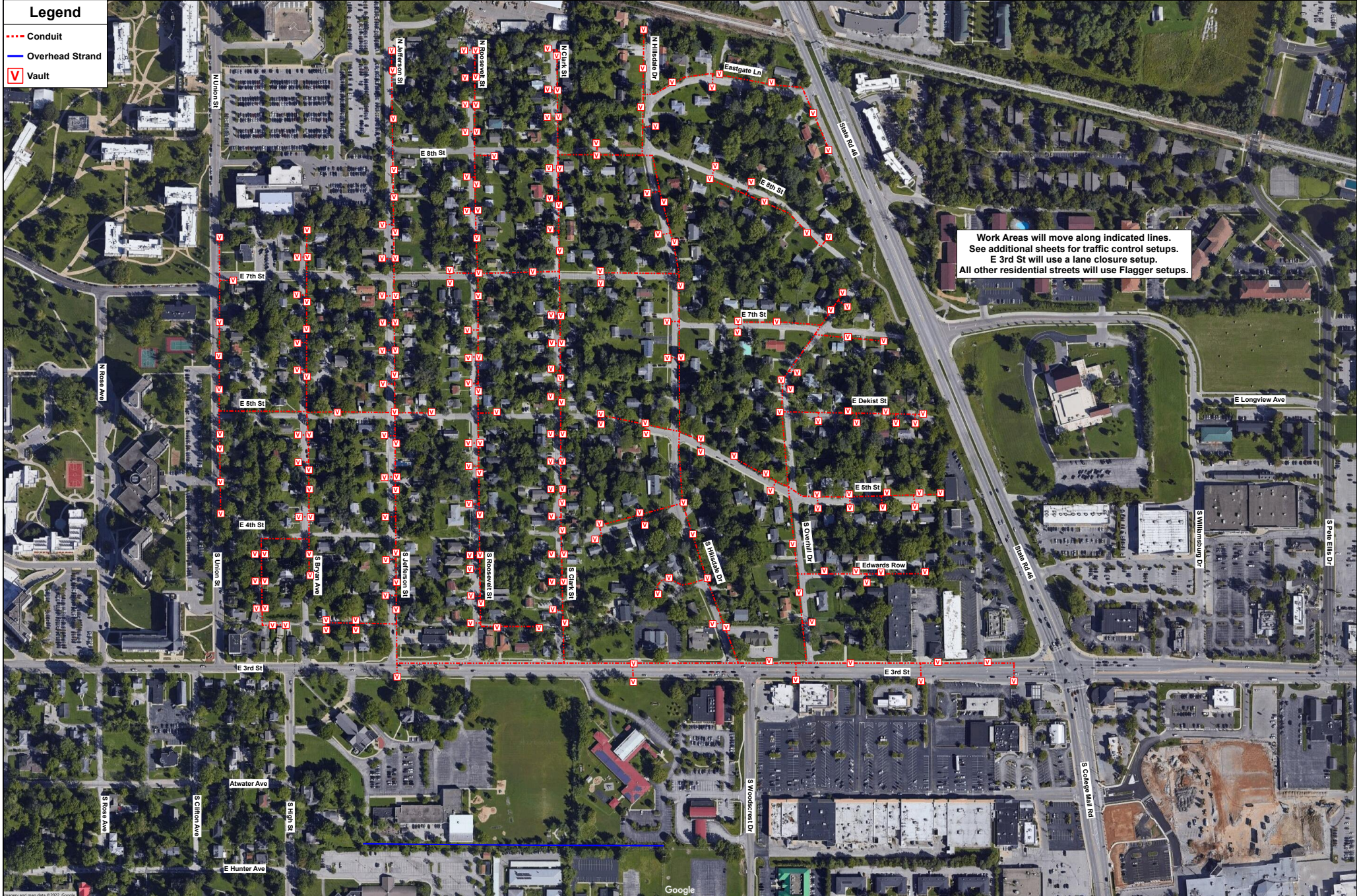

Spacing Charts Based on MUTCD Must be Approved by an Engineer

Speed (MPH) Prior To Road Work	SIGN SPACING, FT.		BUFFER SPACE, FT.	TAPER LENGTH, FT.		CHANNELIZING SPACING, FT.	
	Non-Divided Highways	Divided Highways	Length	Shoulder (10 ft Width)	Lane (12 ft Width)	Through Taper	Through Buffer/Work Area
0-35	200	200	250	70	245	35	50
40-45	350	500	360	150	540	40	80
50-55	500	1000	495	185	660	50	100
60-70	SA-1000, SB-1500, SC-2640		730	235	840	60	120
	Urban Low Speed - 100 FT						

APPROVED/ACCEPTED BY:
ENGINEER, OWNER, or PRIME CONTRACTOR

Check for Notice to Proceed.

BLC01b-F22 - E 3rd St - TCP2

Signature: _____

Company: _____



Date: 9/22/2022 Project: BLC01b-F22 - E 3rd St - TCP2 :
: Traffic Control Suggestion For: AEG :
By: Road Runner Safety Services, Inc. : Nathan

Comments:

Drawing not to scale. Traffic control plan must be approved by an engineer. This is a suggestion only. Road Runners Safety Services, Inc. has no liability for this suggested traffic control plan. Actual placement and spacing of all traffic control devices will depend on field conditions and must conform to MUTCD standards.

Legend

- ADA Barricade
- Arrow Board
- Channelizer
- Flagger (Person)
- Sign
- Vault
- Work Area

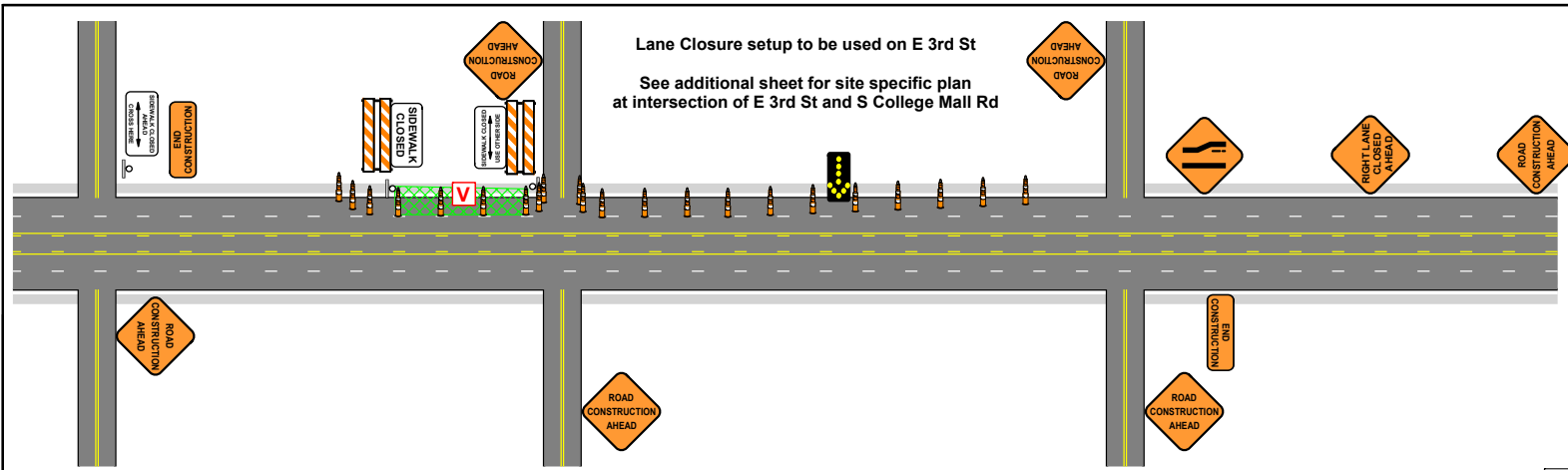

Road Construction Ahead signs to be placed on all side streets within work area. Sidewalk Closed Ahead Cross Here signs to be placed at nearest crossing.

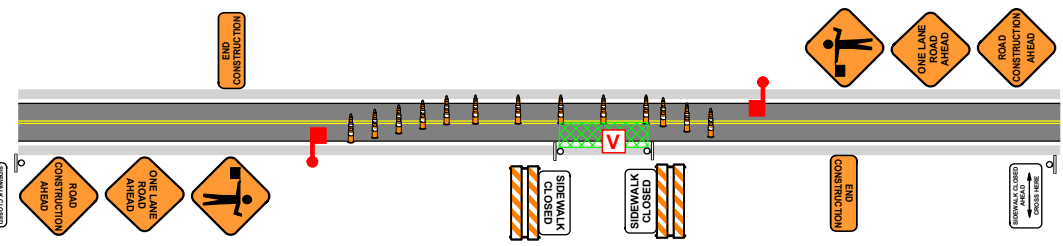
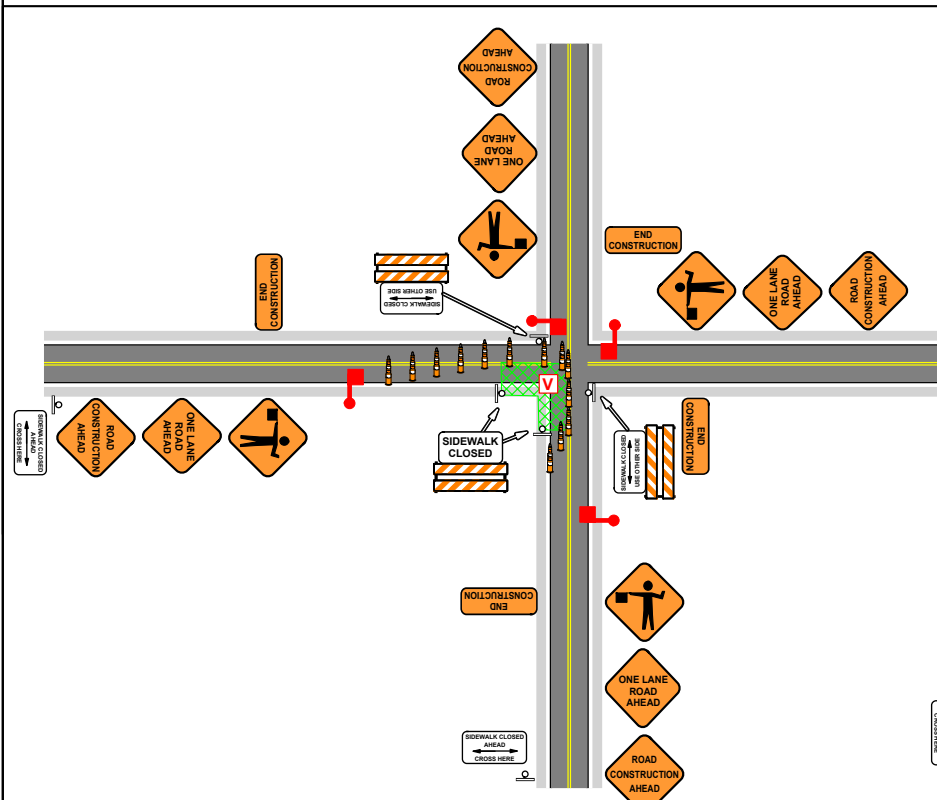

Spacing Charts Based on MUTCD Must be Approved by an Engineer

Speed (MPH) Prior To Road Work	SIGN SPACING, FT.		BUFFER SPACE, FT.	TAPER LENGTH, FT.		CHANNELIZING SPACING, FT.	
	Non-Divided Highways	Divided Highways		Shoulder (10 ft Width)	Lane (12 ft Width)	Through Taper	Through Buffer/Work Area
0-35	200	200	250	70	245	35	50
40-45	350	500	360	150	540	40	80
50-55	500	1000	495	185	660	50	100
60-70	SA-1000, SB-1500, SC-2640 Urban Low Speed - 100 FT		730	235	840	60	120

APPROVED/ACCEPTED BY:
ENGINEER, OWNER, or PRIME CONTRACTOR
 Check for Notice to Proceed.
BLC01b-F22 - E 3rd St - TCP3

Signature: _____

Company: _____

Date: 9/23/2022 **Project:** BLC01b-F22 - E 3rd St - TCP3 :
Traffic Control Suggestion For: AEG :
By: Road Runner Safety Services, Inc. : Nathan

Comments:
Drawing not to scale. Traffic control plan must be approved by an engineer. This is a suggestion only. Road Runners Safety Services, Inc. has no liability for this suggested traffic control plan. Actual placement and spacing of all traffic control devices will depend on field conditions and must conform to MUTCD standards.



Google Earth



CITY OF BLOOMINGTON RIGHT-OF-WAY USE PERMIT APPLICATION

401 N Morton Street, Suite 130
P.O. Box 100
Bloomington, IN 47402

Phone: (812) 349-3913
Fax: (812) 349-3520
Email:
engineering@bloomington.in.gov

ROW EXCAVATION ROW USE

ADDRESS OF ROW ACTIVITY: E 3rd St

A. APPLICANT/AGENT INFORMATION:		D. TRAFFIC CONTROL DEVICES*:	
APPLICANT NAME: <u>Bret Simons</u>		<input checked="" type="checkbox"/> CONES	<input type="checkbox"/> ARROWBOARD
E-MAIL: <u>bret.simons@aeq.cc</u>		<input type="checkbox"/> LIGHTED BARRELS	<input checked="" type="checkbox"/> TYPE 3 BARRICADES
COMPANY: <u>Atlantic Engineering Group</u>		<input checked="" type="checkbox"/> FLAGGERS	<input type="checkbox"/> BPD OFFICER
ADDRESS: <u>P.O. Box 349</u>		*PROVIDING MUTCD COMPLIANT TEMPORARY TRAFFIC CONTROL DEVICES AND MAINTENANCE OF TRAFFIC (MOT) PLAN IS YOUR RESPONSIBILITY AND REQUIRED. See page 3 for additional MOT resources; the graph paper can be used for your MOT site plan if needed or you can submit a separate sheet	
CITY, STATE, ZIP: <u>Buford, GA 30515</u>		E. METERED PARKING SPACES NEEDED: <input type="checkbox"/> Y <input type="checkbox"/> N	
24-HR EMERGENCY CONTACT NAME: <u>(706)654-2298</u>		IT IS THE RESPONSIBILITY OF THE APPLICANT TO RESERVE PARKING METER(S) APPLICATION LOCATED: https://bloomington.in.gov/transportation/parking/moving OR CONTACT PARKING SERVICES WITH QUESTIONS AT (812)349-3436	
24-HR CONTACT PHONE #: _____		F. IS THIS A <input type="checkbox"/> CBU* <input type="checkbox"/> COUNTY* <input type="checkbox"/> IU* <input type="checkbox"/> NP* PROJECT?	
INSURANCE #*: <u>883724951</u> COMPANY: <u>ACORD</u>		PROJECT NAME: <u>BLC01b-F22 - E 3rd St</u>	
BOND #*: <u>1160465</u> COMPANY: <u>LEXON</u>		PROJECT #: <u>BLC01b-F22 - E 3rd St</u>	
*INSURANCE & BOND MUST BE ON FILE WITH THE CITY BEFORE PERMIT WILL BE ISSUED		PROJECT MGR.: <u>Lex Mullins</u>	
SUBCONTRACTOR INFORMATION		PROJECT MGR. #: <u>215-847-8819</u>	
(LIST ALL COMPANIES WORKING UNDER PRIMARY CONTRACTOR PERMIT)		*CBU = CITY OF BLOOMINGTON UTILITIES *COUNTY = MONROE COUNTY	
COMPANY NAME: _____		*IU = INDIANA UNIVERSITY *NP = NOT-FOR-PROFIT AGENCY	
B. WORK DESCRIPTION:		G. EXCAVATIONS:	
<input type="checkbox"/> POD/DUMPSTER <input type="checkbox"/> CRANE <input type="checkbox"/> SCAFFOLDING <input checked="" type="checkbox"/> CONSTRUCTION USE*		SQ FT OF PAVEMENT* EXCAVATIONS : <u>N/A</u>	
(EXPLAIN): <u>Excavation</u>		*PAVEMENT INCLUDES: IN OR UNDER CONCRETE, OR ASPHALT INCLUDING CURBS	
EXCAVATION, LONG TERM USE FOR STORAGE OF MATERIAL/EQUIPMENT/WALKAROUND		SQ FT OF NON-PAVEMENT EXCAVATIONS: <u>780 Sq Ft</u>	
C. RIGHT OF WAY TO BE USED/CLOSED:		*DIRT, GRASS, GRAVEL, LANDSCAPE AREA OR OTHER UNPAVED SURFACE	
STREET NAME 1: <u>E 3rd St</u>		LINEAL FT OF BORE*: <u>26,015 Lineal Feet</u>	
1ST INTERSECTING STREET NAME: _____		*BORE PITS SHALL BE CALCULATED AS SQ FT EXCAVATIONS	
2ND INTERSECTING STREET NAME: _____		# OF POLE INSTALLATIONS/REMOVAL: <u>N/A</u>	
<input type="checkbox"/> ROAD CLOSURE <input checked="" type="checkbox"/> LANE CLOSURE 1 <input checked="" type="checkbox"/> 2 <input type="checkbox"/> 3 <input type="checkbox"/>		SQ FT OF SIDEWALK RECONSTRUCTION*: <u>N/A</u>	
<input checked="" type="checkbox"/> SIDEWALK* <input type="checkbox"/> BIKE LANE <input type="checkbox"/> OTHER		*CONCRETE OR ASPHALT SIDEWALK/PATH BEING IMPROVED/REPLACED	
TRANSIT STOP? <input type="checkbox"/> Y <input type="checkbox"/> N PARKING LANE(S)** <input type="checkbox"/> Y <input type="checkbox"/> N **NON-METERED		SQ FT OF SIDEWALK NEW CONSTRUCTION*: <u>N/A</u>	
START DATE: <u>Oct 14th</u> END DATE: _____ # OF DAYS*: <u>30</u>		*CONCRETE OR ASPHALT SIDEWALK/PATH THAT IS NEW INFRASTRUCTURE	
STREET NAME 2: _____		# RESIDENTIAL DRIVEWAY INSTALLATION: <u>N/A</u>	
1ST INTERSECTING STREET NAME: _____		 <p>TO SUBMIT A LOCATE REQUEST 24 HRS A DAY, 7 DAYS A WEEK CALL 811 OR 800-382-5544 CALL 2 WORKING DAYS BEFORE YOU DIG. ITS THE LAW.</p>	
2ND INTERSECTING STREET NAME: _____			
<input type="checkbox"/> ROAD CLOSURE <input type="checkbox"/> LANE CLOSURE 1 <input type="checkbox"/> 2 <input type="checkbox"/> 3 <input type="checkbox"/>		H. INDEMNIFICATION AGREEMENT:	
<input type="checkbox"/> SIDEWALK* <input type="checkbox"/> BIKE LANE <input type="checkbox"/> OTHER		The petitioner/applicant hereby agrees to hold harmless, defend and to indemnify the City of Bloomington from or against all claims, action, damages and expenses, including but not limited to reasonable attorney's fees or any alleged injury and/or death to any person or damage to any property arising, or alleged to have arisen out of any act of commission or omission on the part of the petitioner/applicant, his/her heirs, successors, or assigns regardless of whether such acts are the direct or indirect result of the public right-of-way use pursuant to this permit grant.	
TRANSIT STOP? <input type="checkbox"/> Y <input type="checkbox"/> N PARKING LANE(S)** <input type="checkbox"/> Y <input type="checkbox"/> N **NON-METERED		I AFFIRM, UNDER THE PENALTIES FOR PERJURY, THAT THE FOREGOING REPRESENTATIONS ARE TRUE.	
START DATE: _____ END DATE: _____ # OF DAYS*: _____		PRINT NAME: <u>Bret Simons</u>	
*SIDEWALK CLOSURES FOR A PERIOD OR PERIODS TOTALING 24HRS OR MORE SHALL INSTALL A WALKAROUND UNLESS OTHERWISE APPROVED DURING REVIEW		SIGNATURE: <u>Bret Simons</u>	
STANDARD CLOSURE HOURS MON-FRI*: 9:00 AM - 3:00 PM & 6:00 PM - 9:00 PM		DATE: <u>9/20/2022</u>	
STANDARD CLOSURE HOURS <input checked="" type="checkbox"/> *NON-STANDARD CLOSURE HOURS <input type="checkbox"/>			
REQUESTED CLOSURE HOURS: _____ AM - _____ PM			
*non-standard hours may not be allowed near schools, on arterials, or other circumstances and are subject to approval during the permitting process			
BMC 14.09.040 allows work from 6 AM to 10 PM without violating the noise ordinance (7AM to 9PM for pneumatic hammers)			

For Administration Use Only (applicable to CLOSURE approval)

Approved By: _____ BPW City Engineer Director Date: _____

Staff Representative: _____ Phone#: _____ Date: _____

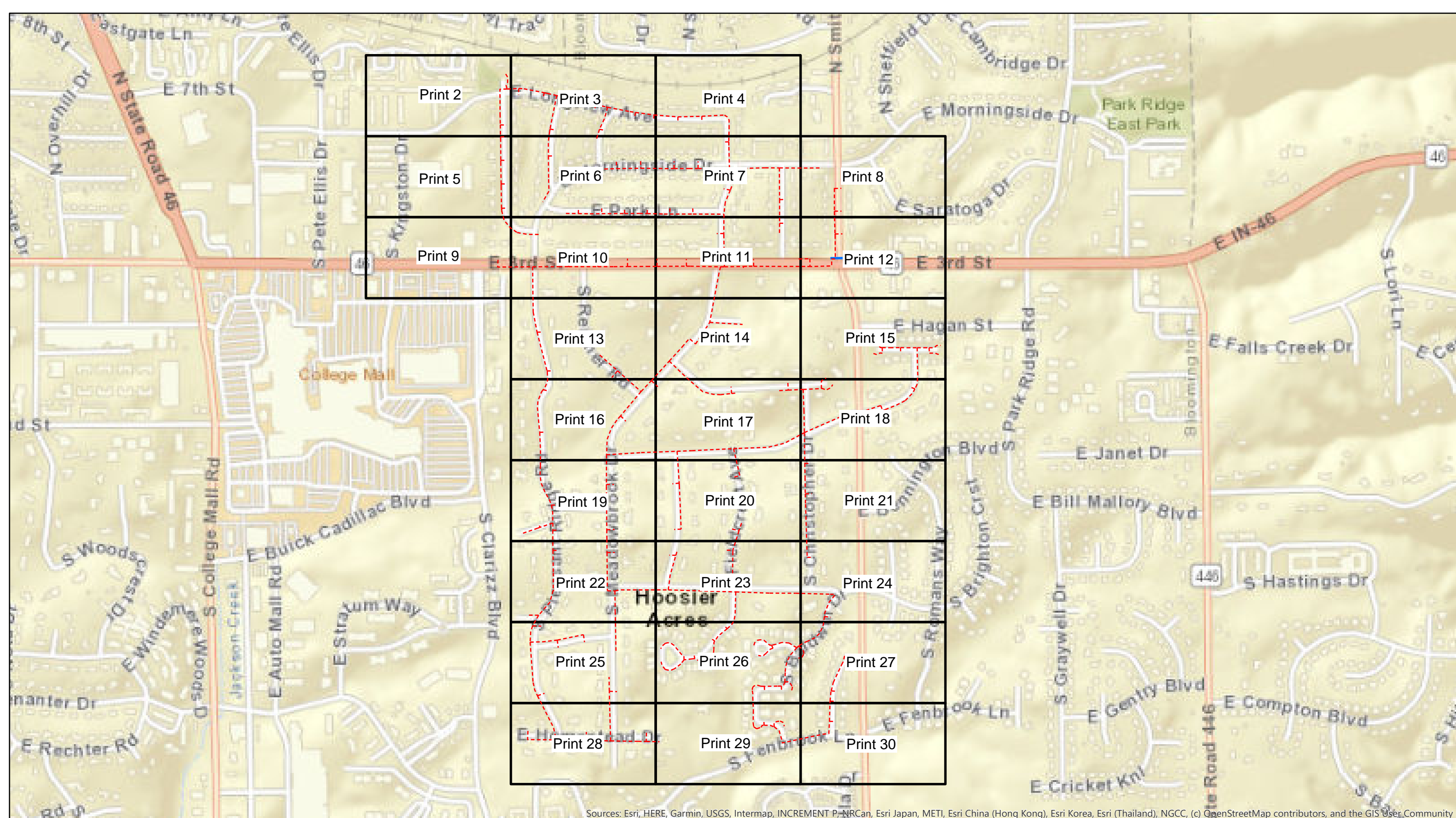

Sources: Esri, HERE, Garmin, USGS, Intermap, INCREMENT P, NRCan, Esri Japan, METI, Esri China (Hong Kong), Esri Korea, Esri (Thailand), NGCC, (c) OpenStreetMap contributors, and the GIS User Community



Legend BLC01b-F19 - N Glenwood Ave W

- Overhead Strand
- - - Conduit
- Grids



City of Bloomington, IN Permit:
Design View

INI	BY	DATE	DESCRIPTION

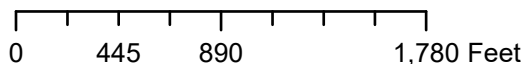

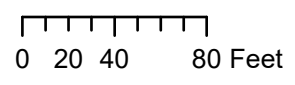
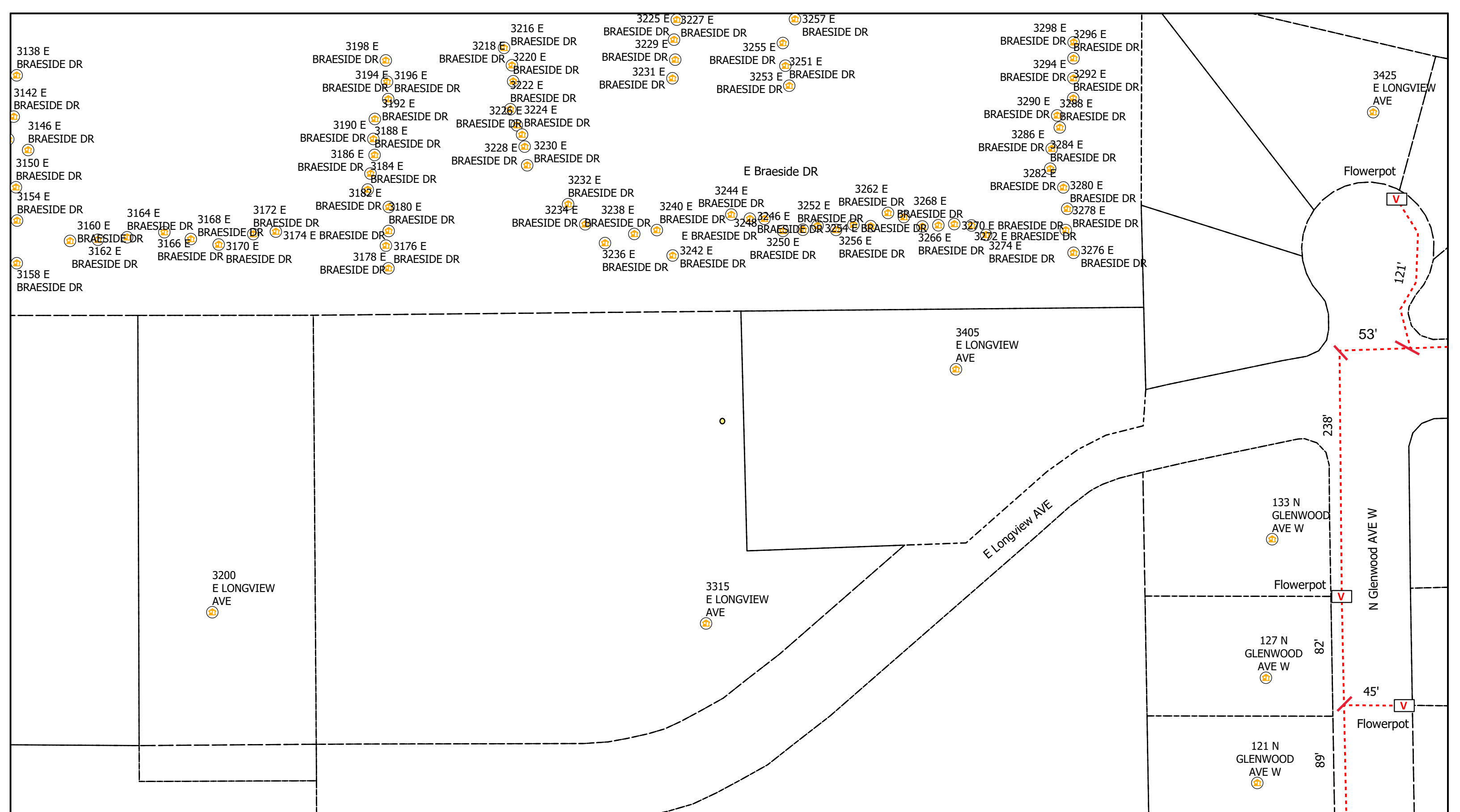

Legend

- Vaults
- Conduit
- Bloomington_Parcels
- Poles
- Address
- Grids
- Overhead Strand
- Other Jurisdiction

All Flowerpots 12" DIA



City of Bloomington, IN Permit:
Design View

INI	BY	DATE	DESCRIPTION



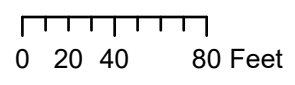
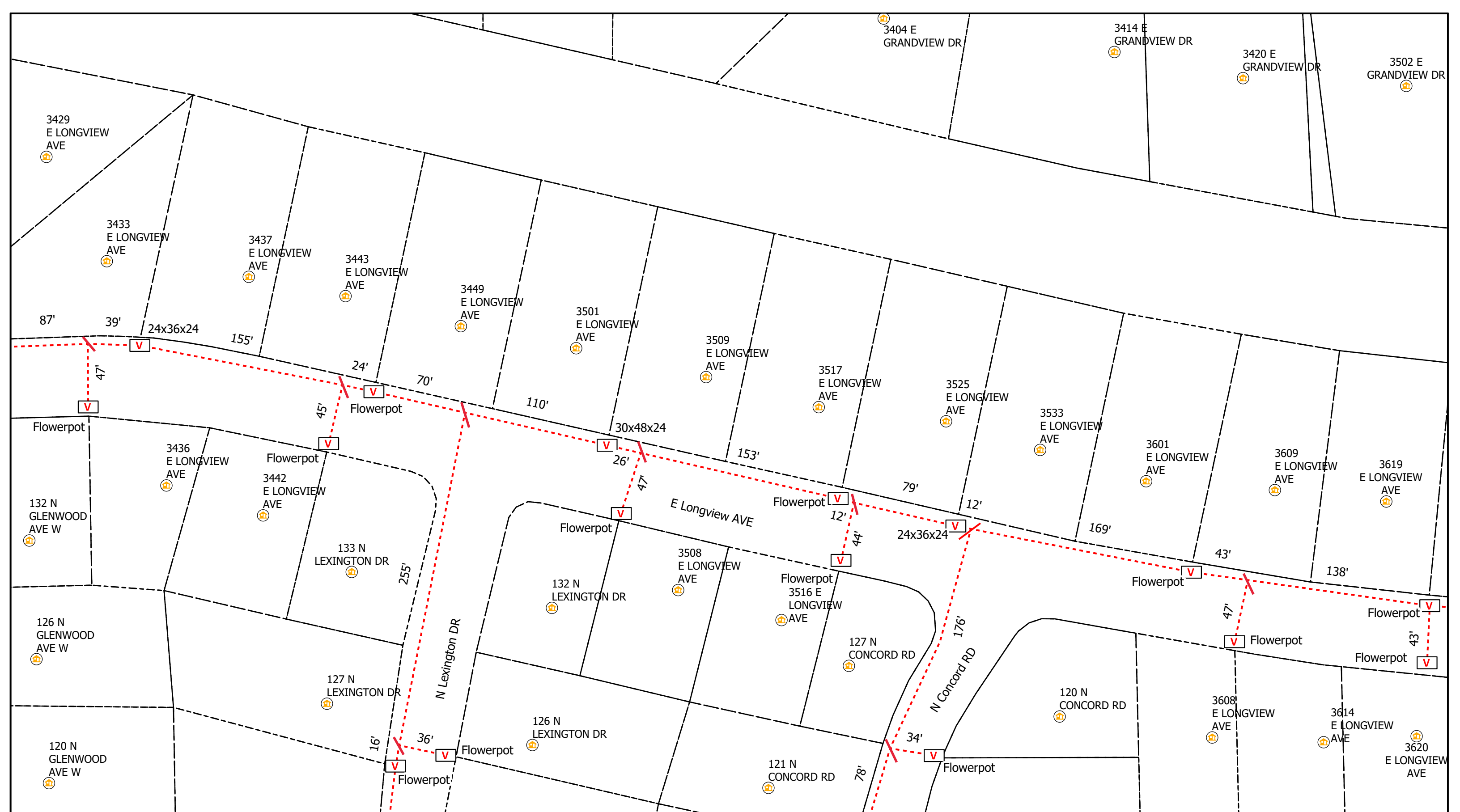

Legend

- V Vaults
- - - Conduit
- Bloomington_Parcels
- Poles
- Ⓜ Address
- Grids
- Overhead Strand
- - - Other Jurisdiction

All Flowerpots 12" DIA



City of Bloomington, IN Permit:
Design View

INI	BY	DATE	DESCRIPTION



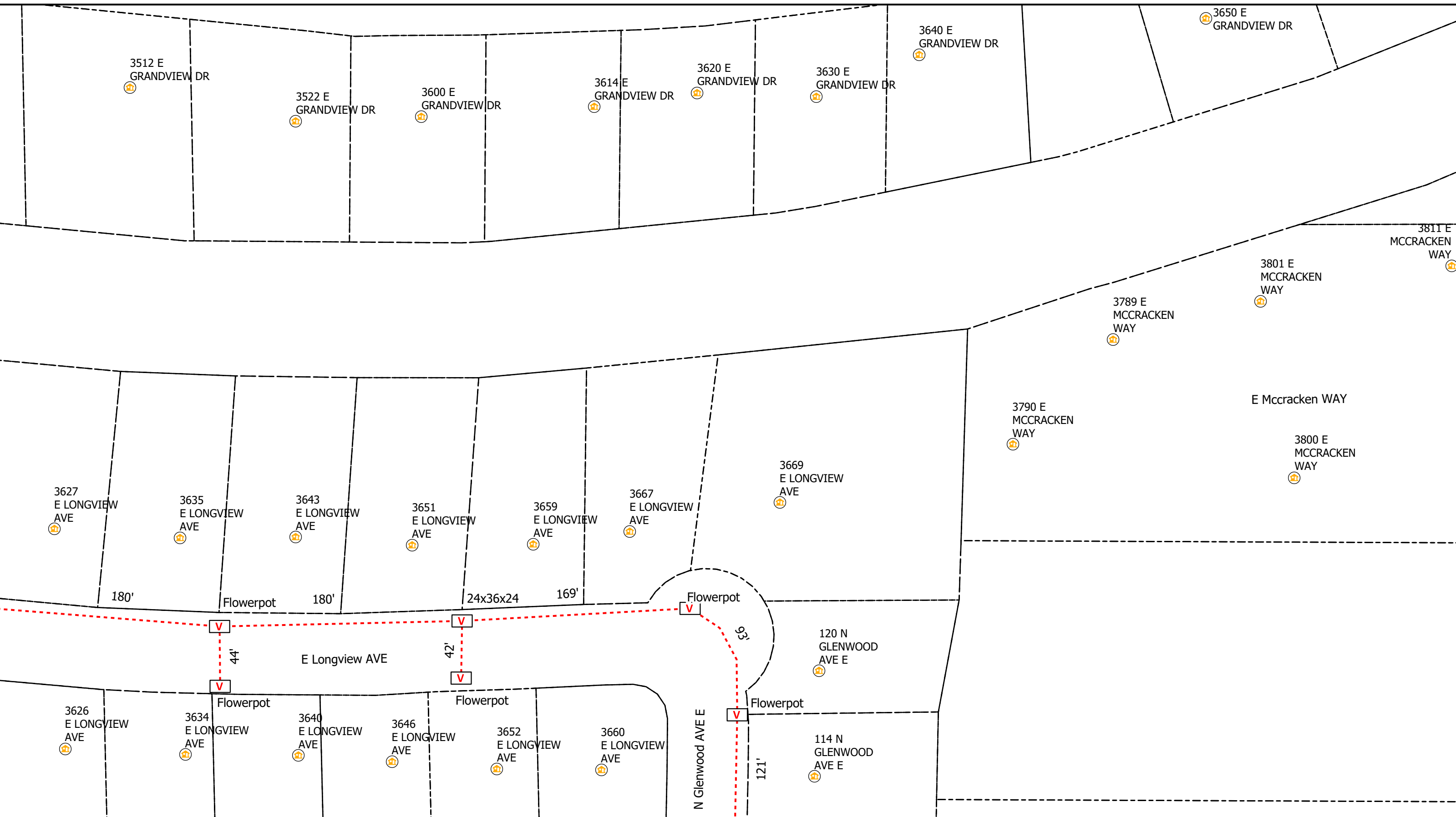

AEG

0 20 40 80 Feet

Legend

- Vaults
- Conduit
- Bloomington_Parcels
- Poles
- Address
- Grids
- Overhead Strand
- Other Jurisdiction

All Flowerpots 12" DIA

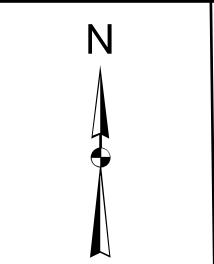

City of Bloomington, IN Permit:
Design View

INI	BY	DATE	DESCRIPTION

Print 4 of 30

100 S
KINGSTON DR

S Kingston DR

123 S
KINGSTON DR

131 S
KINGSTON DR

137 S
KINGSTON DR

143 S
KINGSTON DR

149 S
KINGSTON DR

155 S
KINGSTON DR

161 S
KINGSTON DR

167 S
KINGSTON DR

115 N
GLENWOOD
AVE W

109 N
GLENWOOD
AVE W

103 N
GLENWOOD
AVE W

100 S
GLENWOOD
AVE W

106 S
GLENWOOD
AVE W

112 S
GLENWOOD
AVE W

118 S
GLENWOOD
AVE W

10'

164'

15'

161'

20'

162'

17'

45' Flowerpot

Flowerpot

Flowerpot

45'

Flowerpot

45'

Flowerpot

44'

24x36x24

N Glenwood AVE W



0 20 40 80 Feet

Legend

- Vaults
- Conduit
- Bloomington_Parcels

- Poles
- Address
- Grids
- Overhead Strand
- Other Jurisdiction

All Flowerpots 12" DIA



City of Bloomington, IN Permit:
Design View

INI	BY	DATE	DESCRIPTION



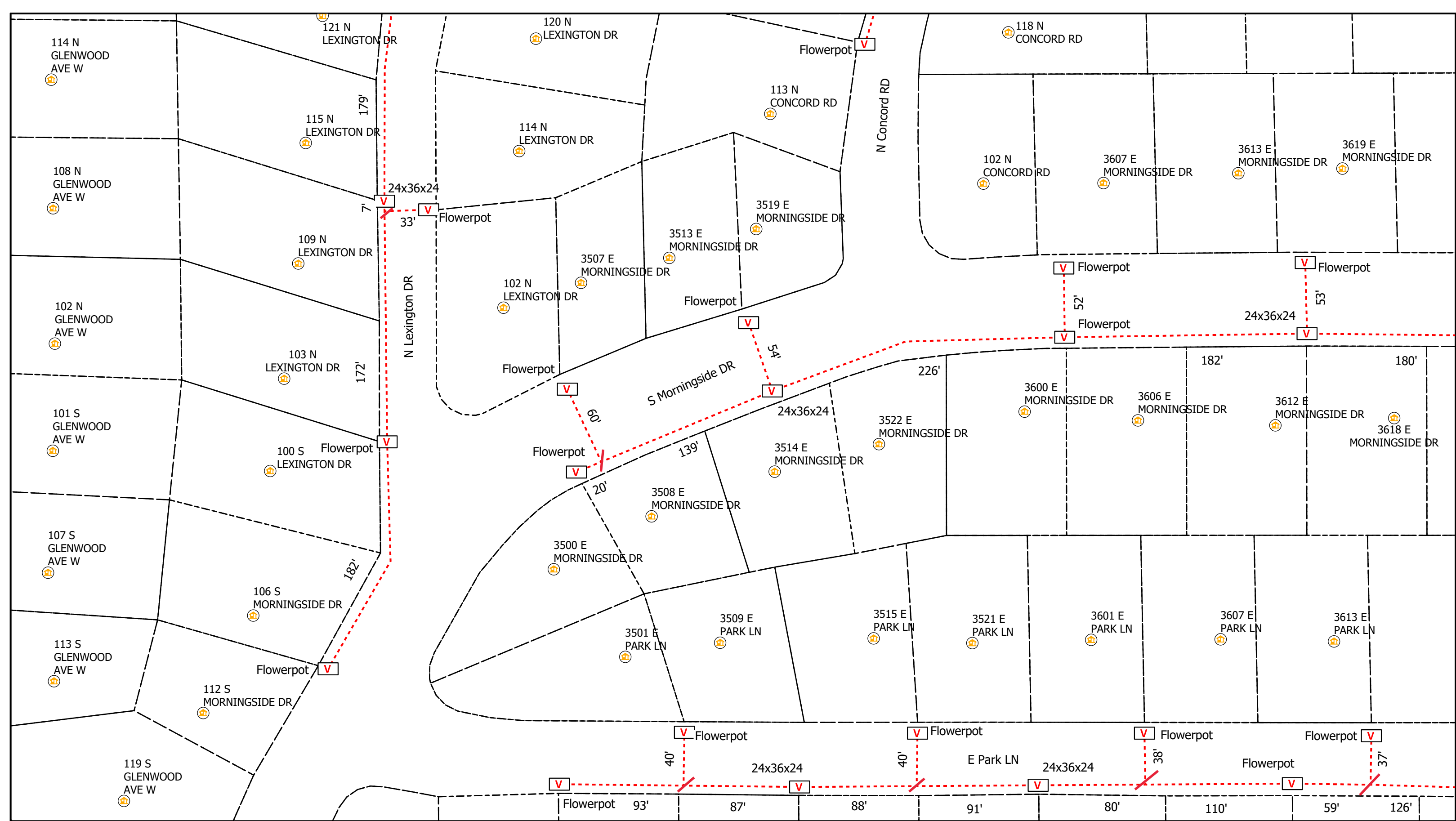

0 20 40 80 Feet

Legend

-  Vaults
-  Conduit
-  Bloomington_Parcels
-  Poles
-  Address
-  Grids
-  Overhead Strand
-  Other Jurisdiction

All Flowerpots 12" DIA



City of Bloomington, IN Permit:
Design View

INI	BY	DATE	DESCRIPTION



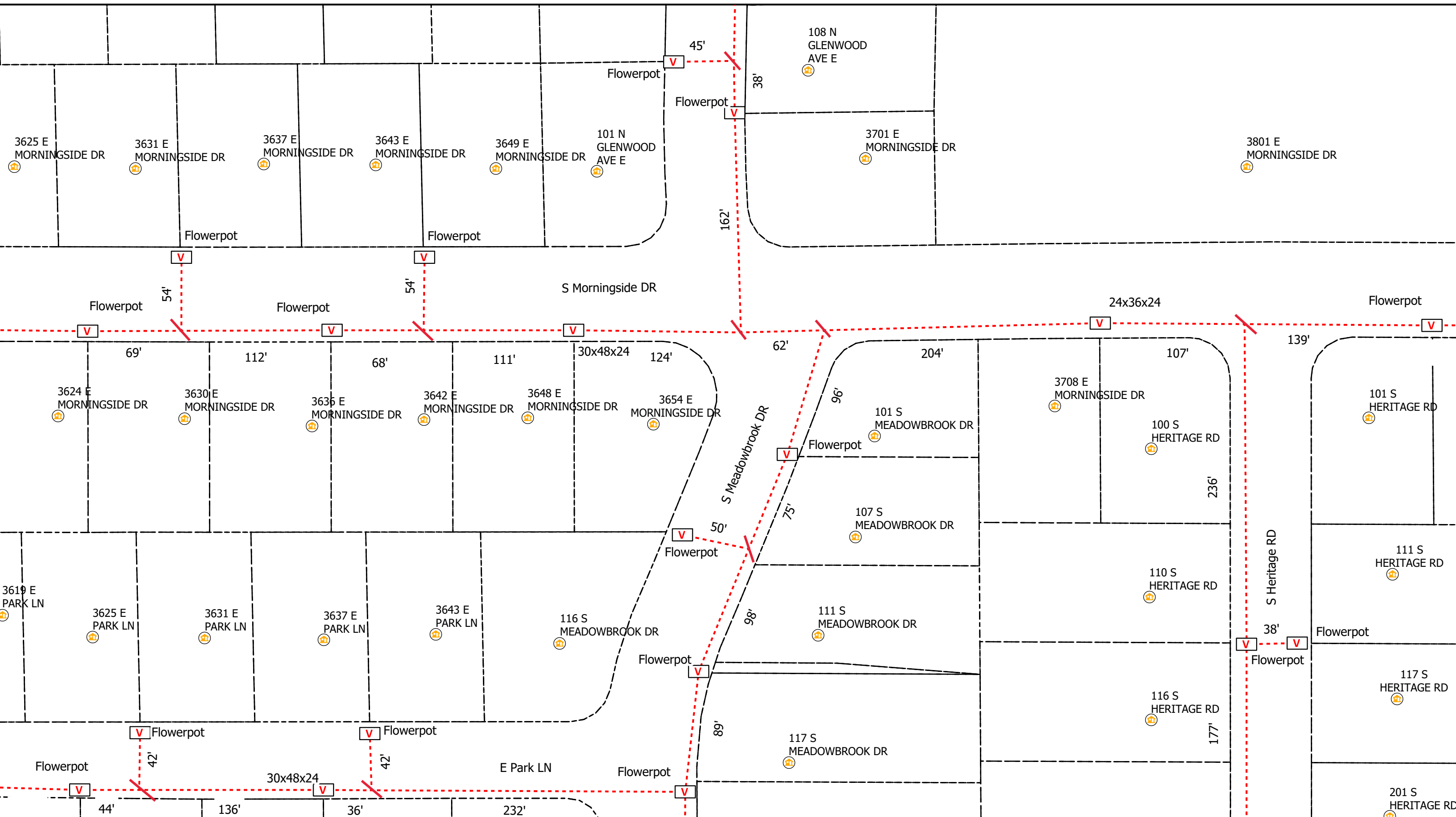

Legend

- V Vaults
- - - Conduit
- Bloomington_Parcels
- Poles
- Ⓜ Address
- Grids
- Overhead Strand
- - - Other Jurisdiction

All Flowerpots 12" DIA

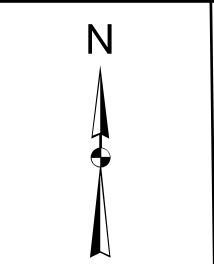





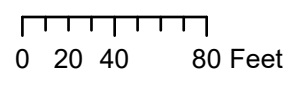
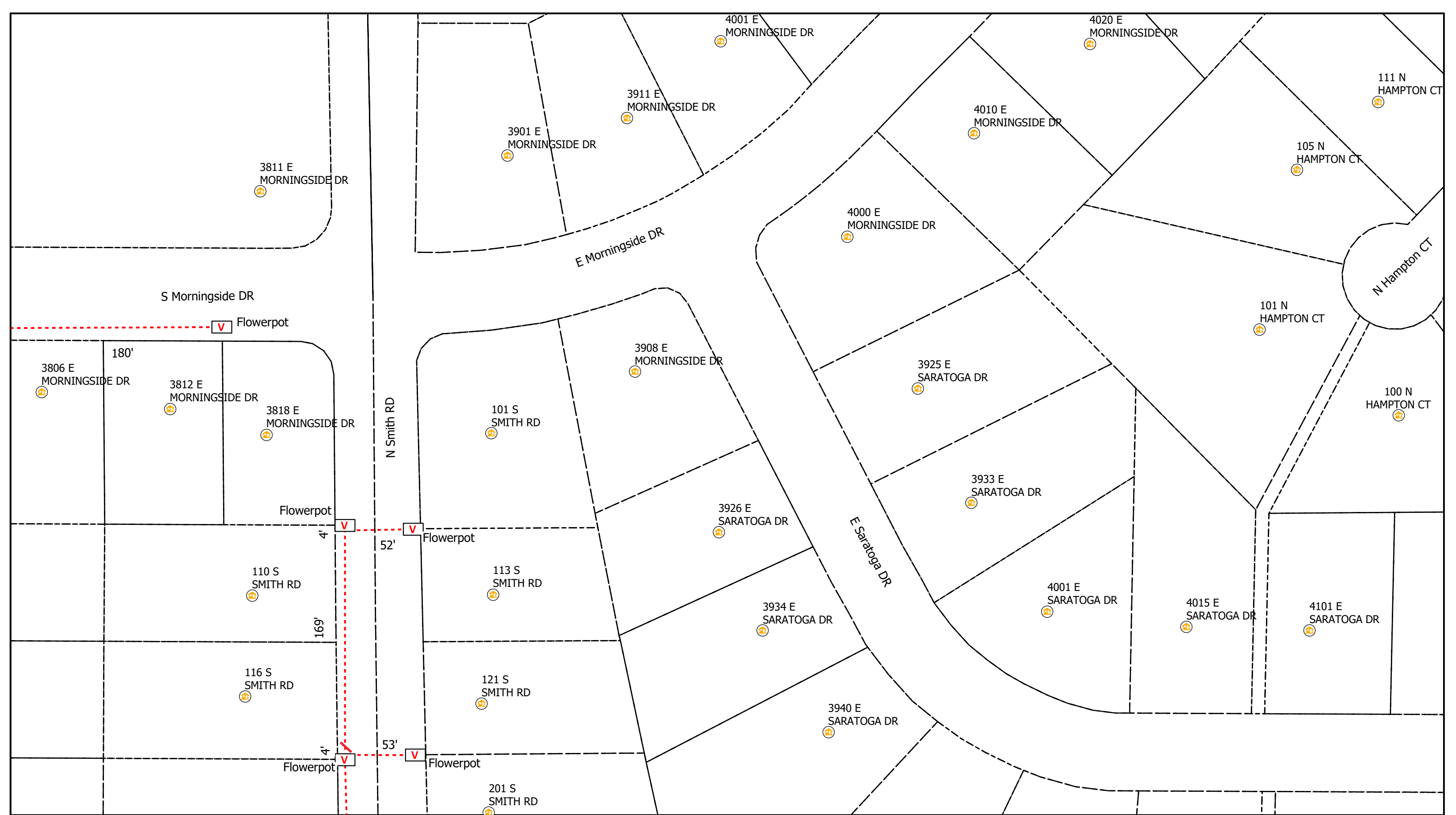

City of Bloomington, IN Permit:
Design View

INI	BY	DATE	DESCRIPTION



Legend

-  Vaults
-  Conduit
-  Bloomington_Parcels
-  Poles
-  Address
-  Grids
-  Overhead Strand
-  Other Jurisdiction

All Flowerpots 12" DIA



City of Bloomington, IN Permit:
Design View

INI	BY	DATE	DESCRIPTION



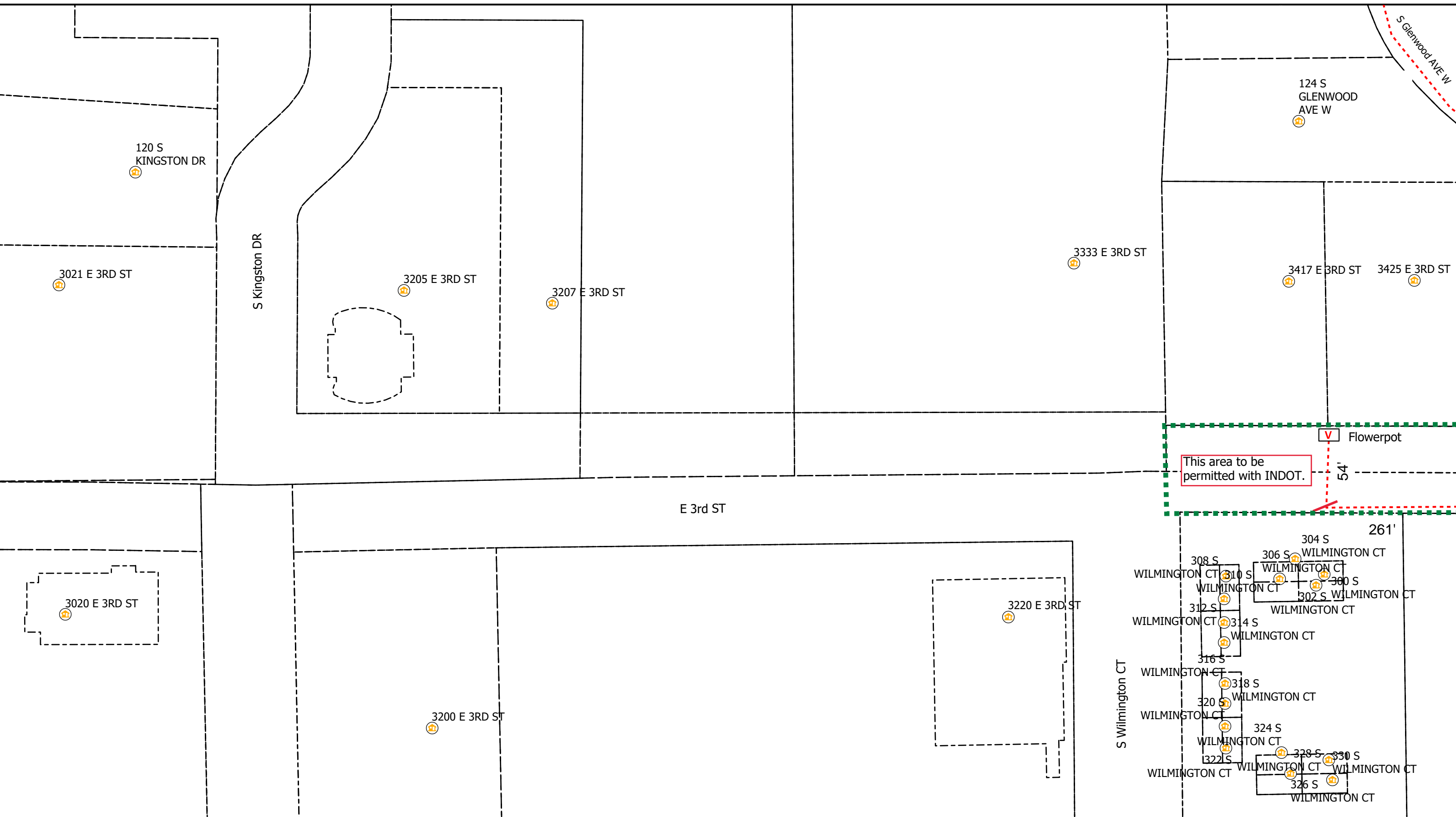

Legend

- Vaults
- Conduit
- Bloomington_Parcels
- Poles
- Address
- Grids
- Overhead Strand
- Other Jurisdiction

All Flowerpots 12" DIA

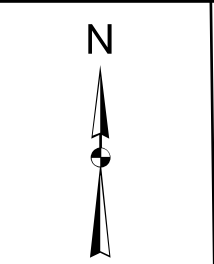

City of Bloomington, IN Permit:
Design View

INI	BY	DATE	DESCRIPTION

Print 9 of 30

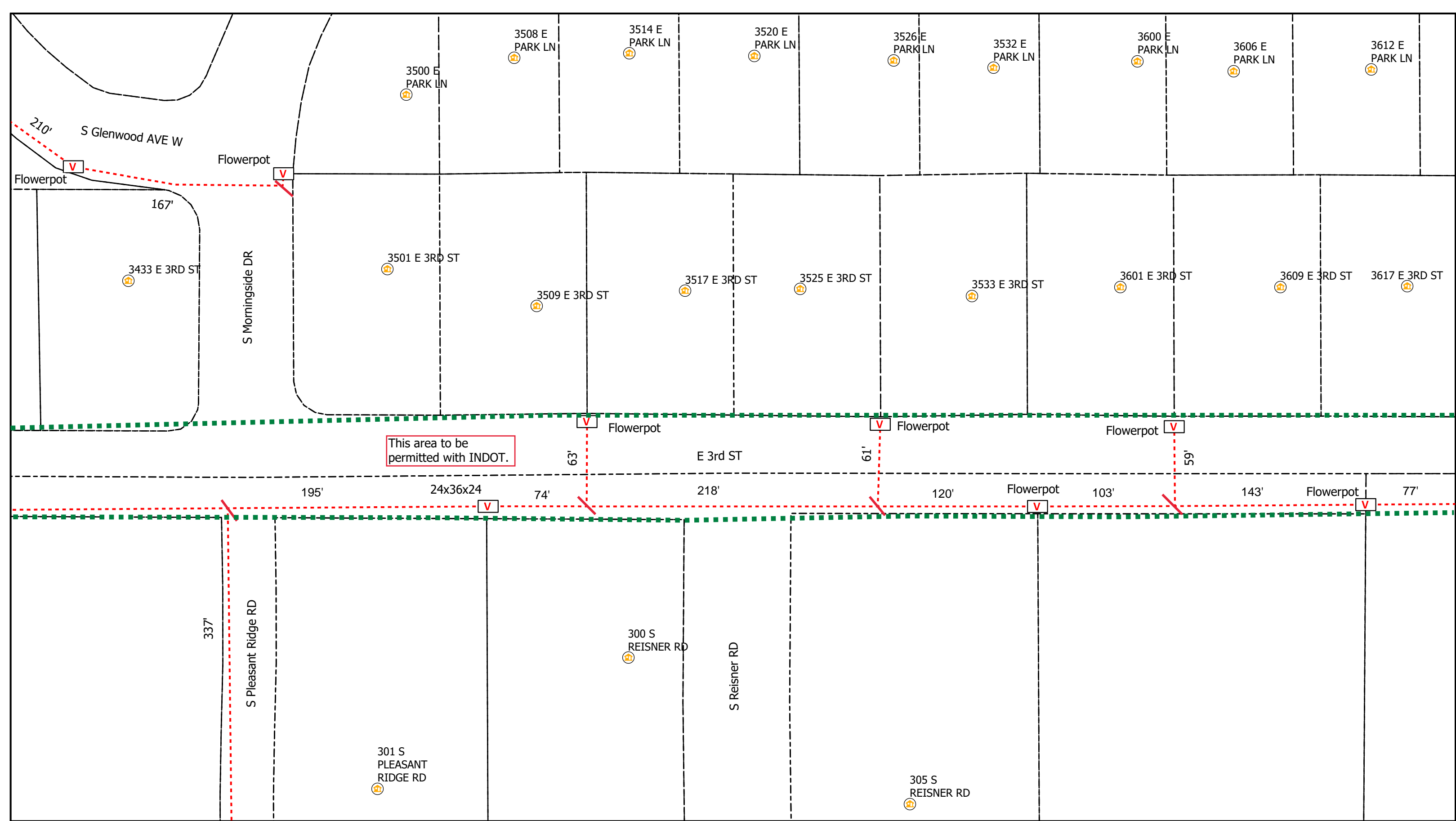

This area to be permitted with INDOT.



0 20 40 80 Feet

Legend

-  Vaults
-  Conduit
-  Bloomington_Parcels
-  Poles
-  Address
-  Grids
-  Overhead Strand
-  Other Jurisdiction

All Flowerpots 12" DIA



City of Bloomington, IN Permit:
Design View

INI	BY	DATE	DESCRIPTION



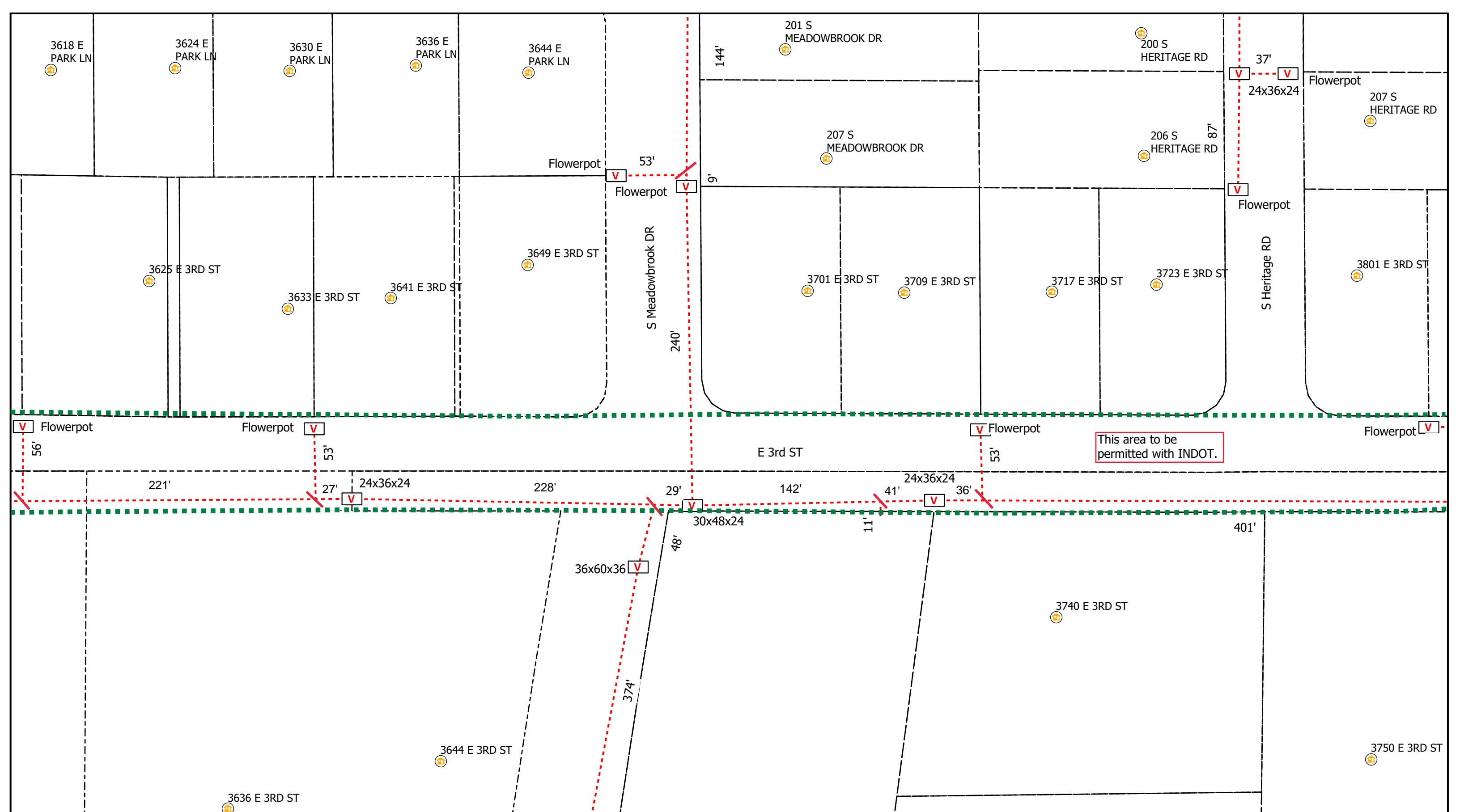

Legend

- Vaults
- Conduit
- Bloomington_Parcels
- Poles
- Address
- Grids
- Overhead Strand
- Other Jurisdiction

All Flowerpots 12" DIA

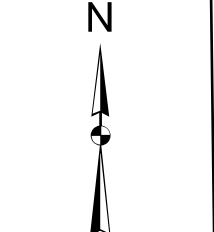

City of Bloomington, IN Permit:
Design View

INI	BY	DATE	DESCRIPTION

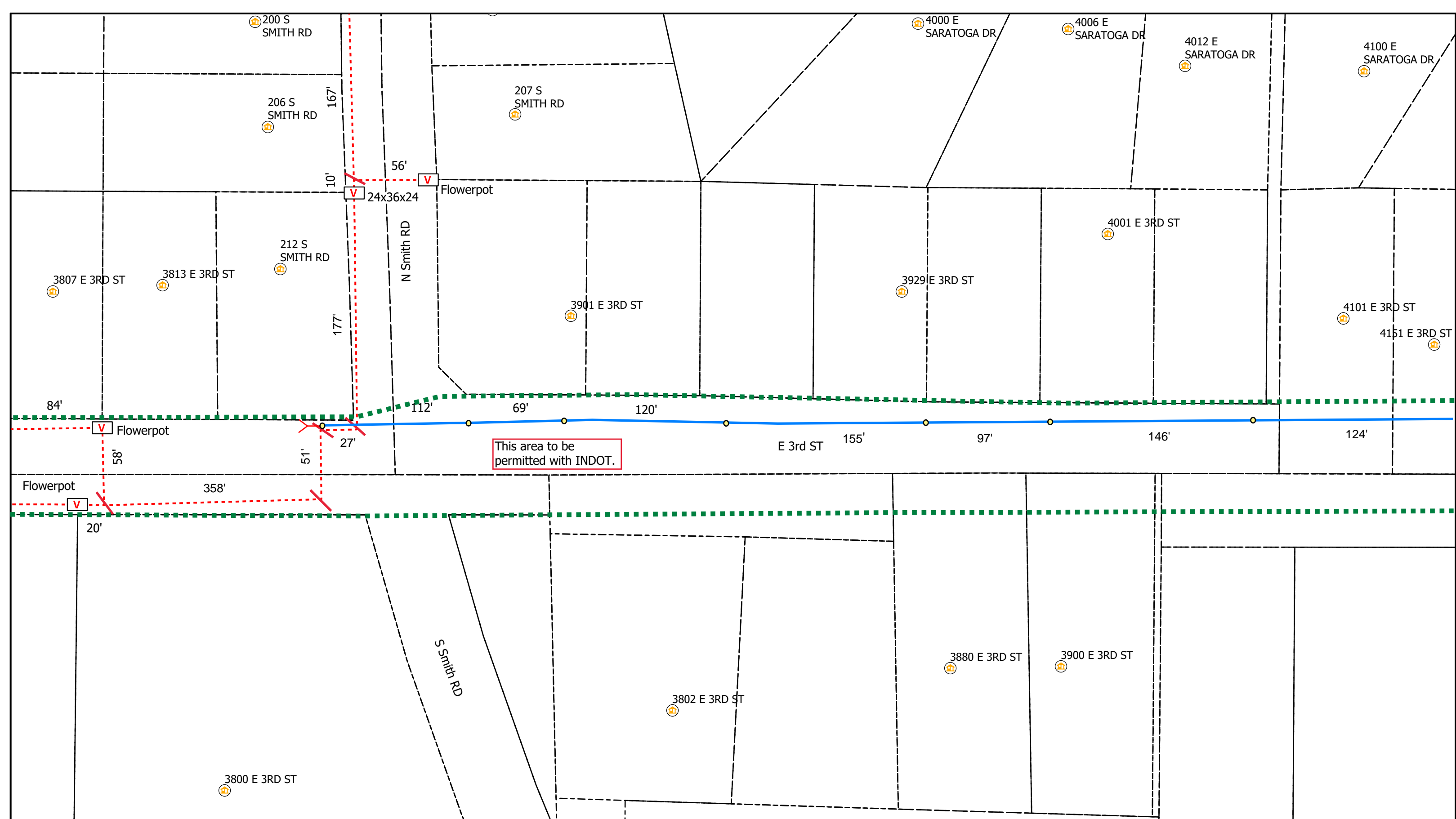

This area to be permitted with INDOT.

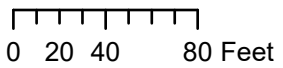

Legend

- Vaults
- Conduit
- Bloomington_Parcels
- Poles
- Address
- Grids
- Overhead Strand
- Other Jurisdiction

All Flowerpots 12" DIA



City of Bloomington, IN Permit:
Design View

INI	BY	DATE	DESCRIPTION



320 S PLEASANT RIDGE RD

3532 E 3RD ST

3620 E 3RD ST

332 S PLEASANT RIDGE RD

361 S PLEASANT RIDGE RD

313 S REISNER RD

424 S MEADOWBROOK DR

400 S PLEASANT RIDGE RD

401 S PLEASANT RIDGE RD

431 S REISNER RD

410 S PLEASANT RIDGE RD

411 S PLEASANT RIDGE RD

438 S MEADOWBROOK DR

24x36x24

402 S REISNER RD

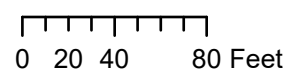

Legend

- Vaults
- Conduit
- Bloomington_Parcels
- Poles
- Address
- Grids
- Overhead Strand
- Other Jurisdiction

All Flowerpots 12" DIA



City of Bloomington, IN Permit:
Design View

INI	BY	DATE	DESCRIPTION



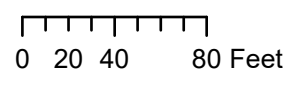
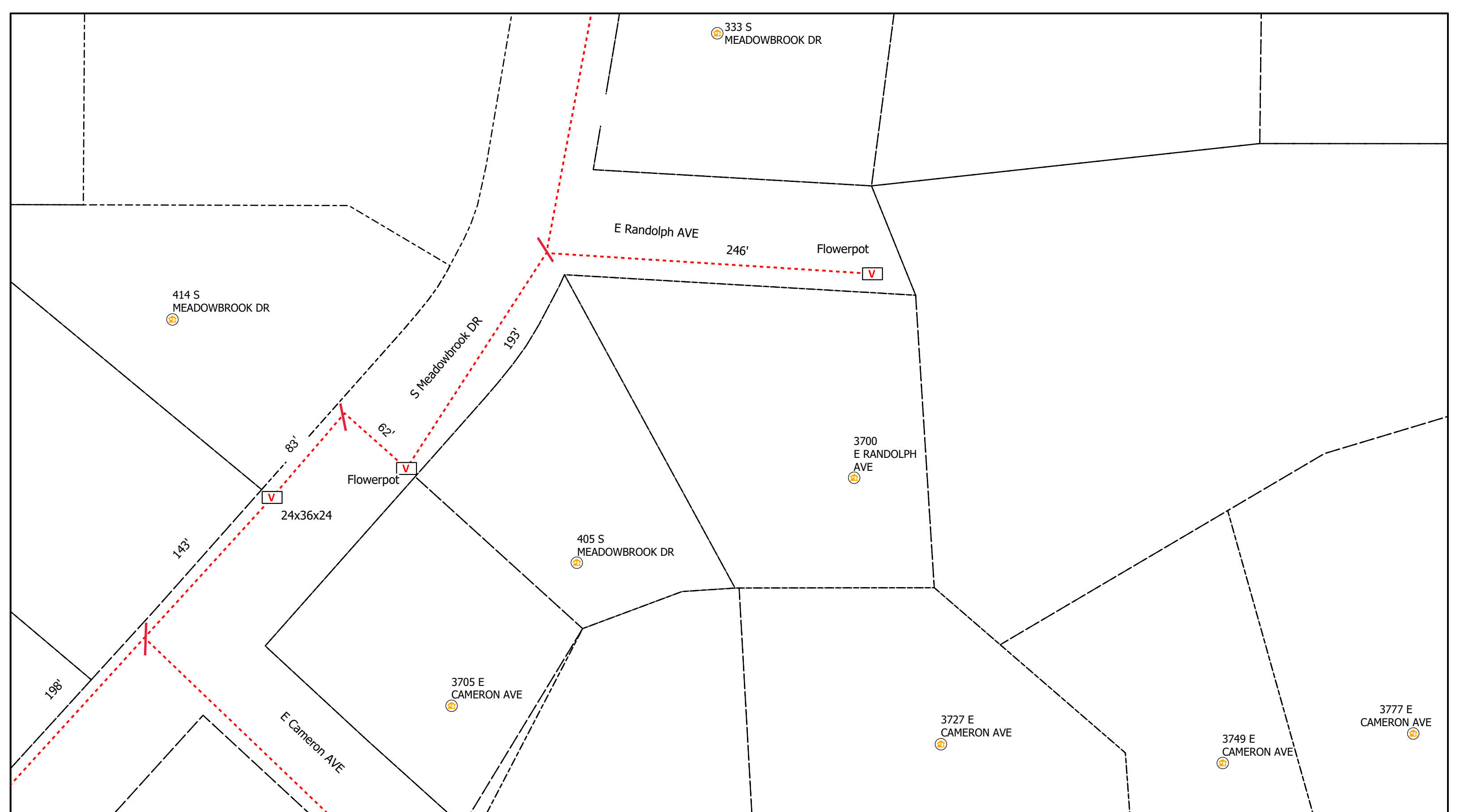

Legend

- V Vaults
- Conduit
- - - - - Bloomington_Parcels
- Poles
- 🏠 Address
- ▭ Grids
- Overhead Strand
- Other Jurisdiction

All Flowerpots 12" DIA



City of Bloomington, IN Permit:
Design View

INI	BY	DATE	DESCRIPTION



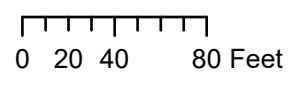
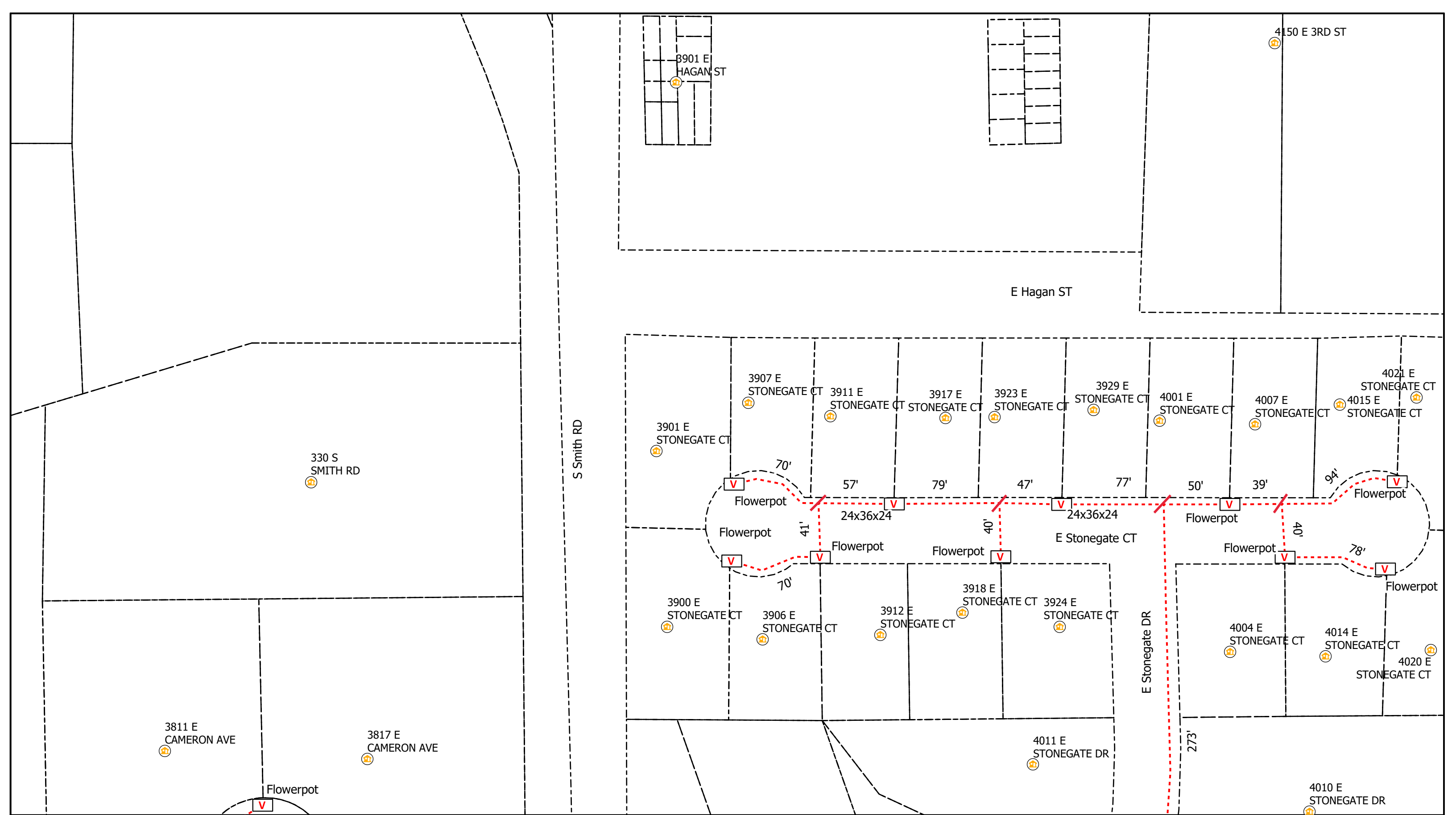

Legend

- Vaults
- Conduit
- Bloomington_Parcels
- Poles
- Address
- Grids
- Overhead Strand
- Other Jurisdiction

All Flowerpots 12" DIA



City of Bloomington, IN Permit:
Design View

INI	BY	DATE	DESCRIPTION



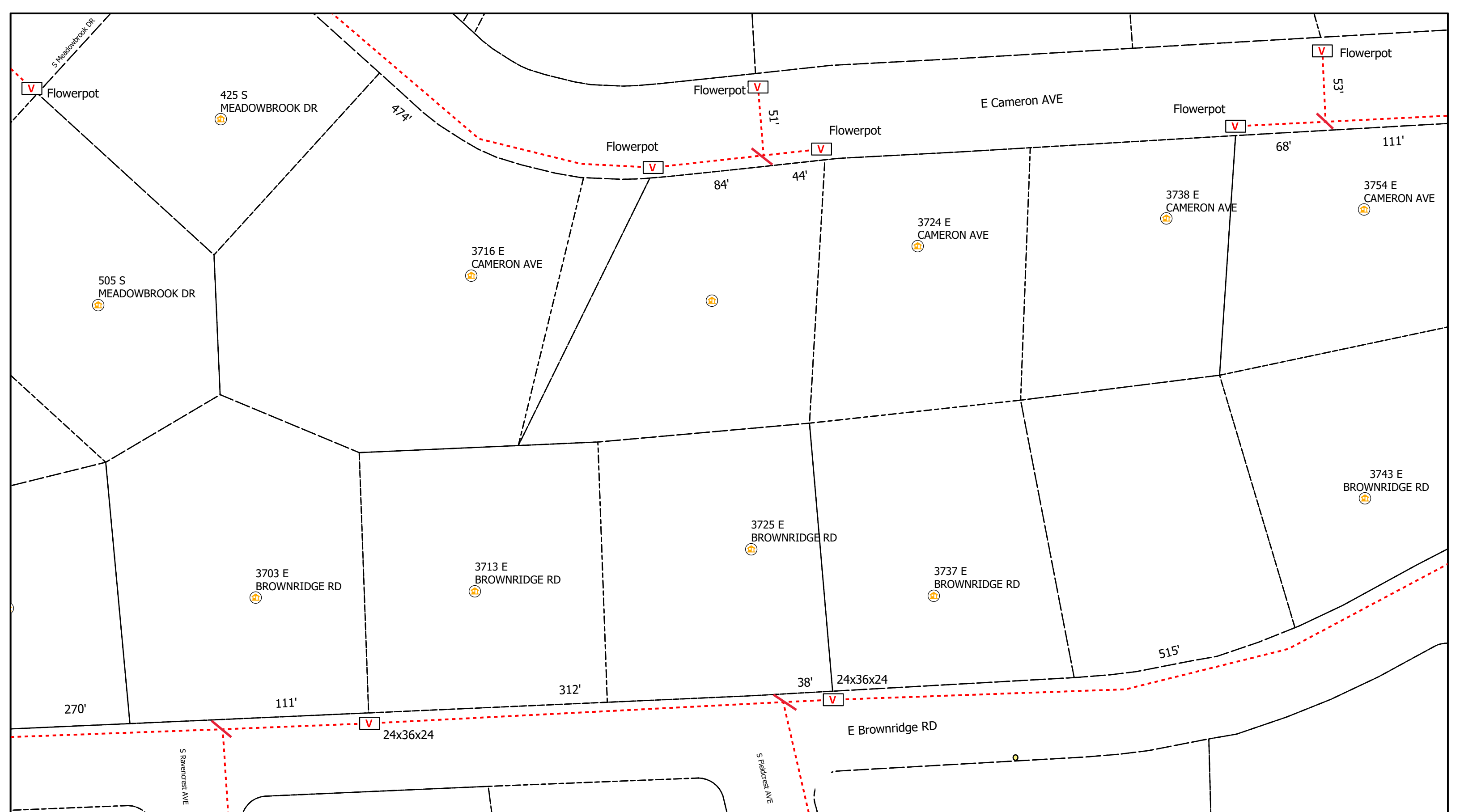

Legend

- V Vaults
- ⋯ Conduit
- Bloomington_Parcels
- Poles
- Ⓜ Address
- Grids
- Overhead Strand
- Other Jurisdiction

All Flowerpots 12" DIA

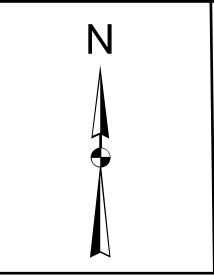

City of Bloomington, IN Permit:
Design View

INI	BY	DATE	DESCRIPTION

Print 17 of 30

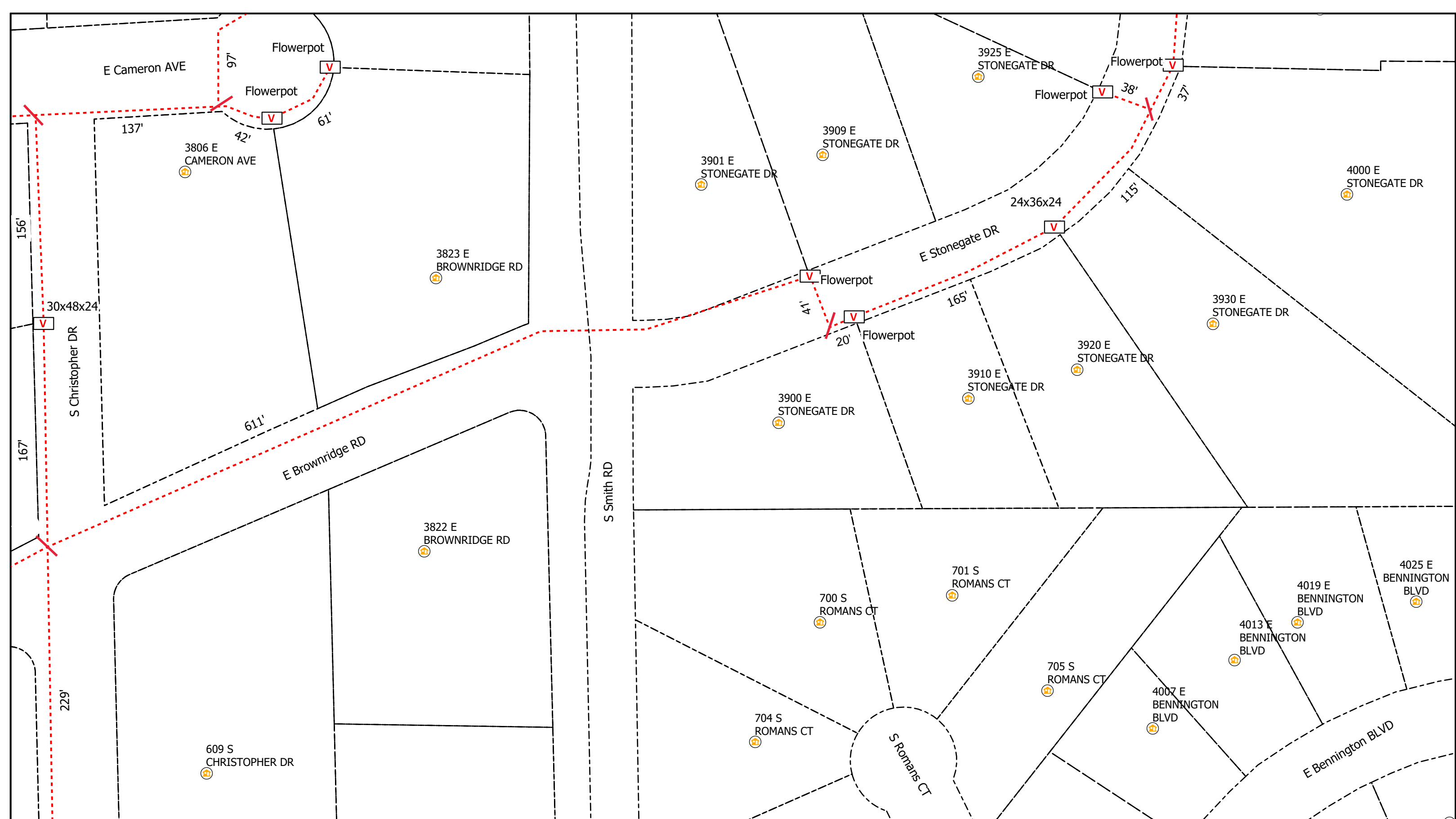

0 20 40 80 Feet

Legend

- Vaults
- Conduit
- Bloomington_Parcels
- Poles
- Address
- Grids
- Overhead Strand
- Other Jurisdiction

All Flowerpots 12" DIA



City of Bloomington, IN Permit:
Design View

INI	BY	DATE	DESCRIPTION



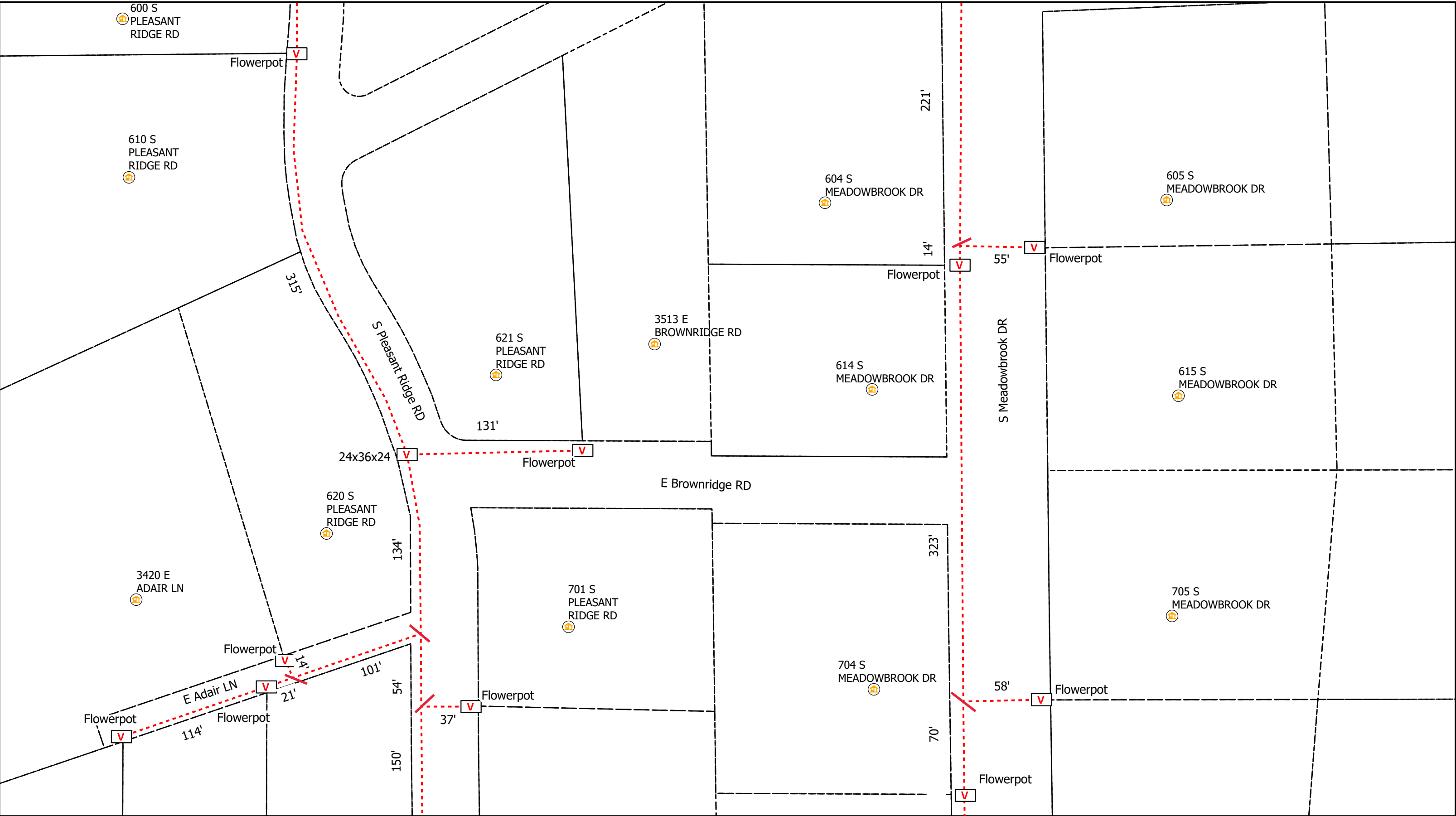

0 20 40 80 Feet

Legend

- V Vaults
- - - Conduit
- Bloomington_Parcels
- Poles
- Ⓜ Address
- Grids
- Overhead Strand
- - - Other Jurisdiction

All Flowerpots 12" DIA



City of Bloomington, IN Permit:
Design View

INI	BY	DATE	DESCRIPTION



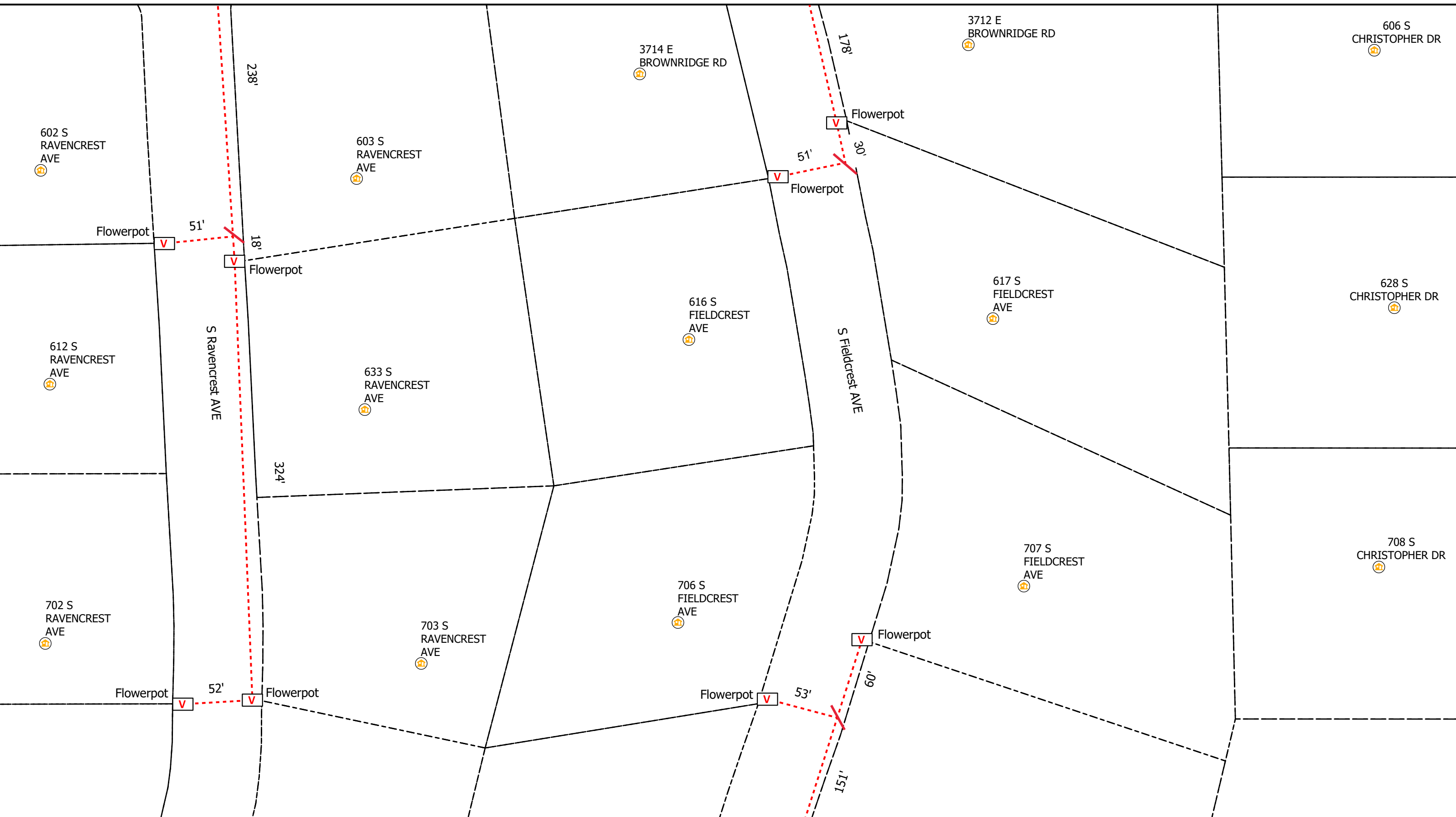

0 20 40 80 Feet

Legend

- V Vaults
- - - Conduit
- Bloomington_Parcels
- Poles
- Ⓜ Address
- Grids
- Overhead Strand
- - - Other Jurisdiction

All Flowerpots 12" DIA

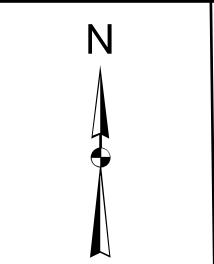

City of Bloomington, IN Permit:
Design View

INI	BY	DATE	DESCRIPTION

Print 20 of 30

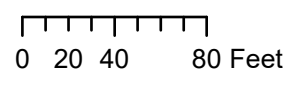
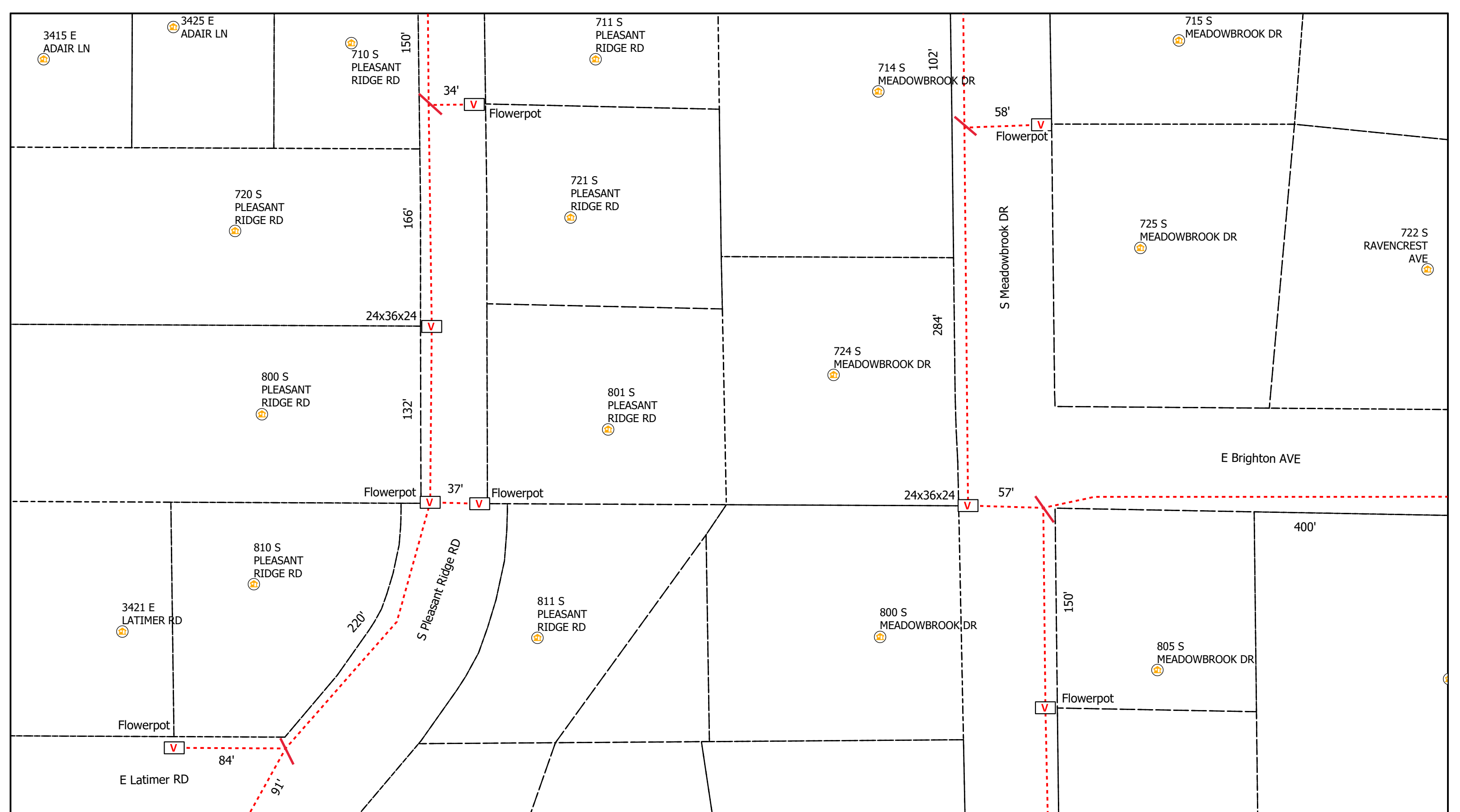

Legend

- Vaults
- Conduit
- Bloomington_Parcels

- Poles
- Address
- Grids
- Overhead Strand
- Other Jurisdiction

All Flowerpots 12" DIA



City of Bloomington, IN Permit:
Design View

INI	BY	DATE	DESCRIPTION



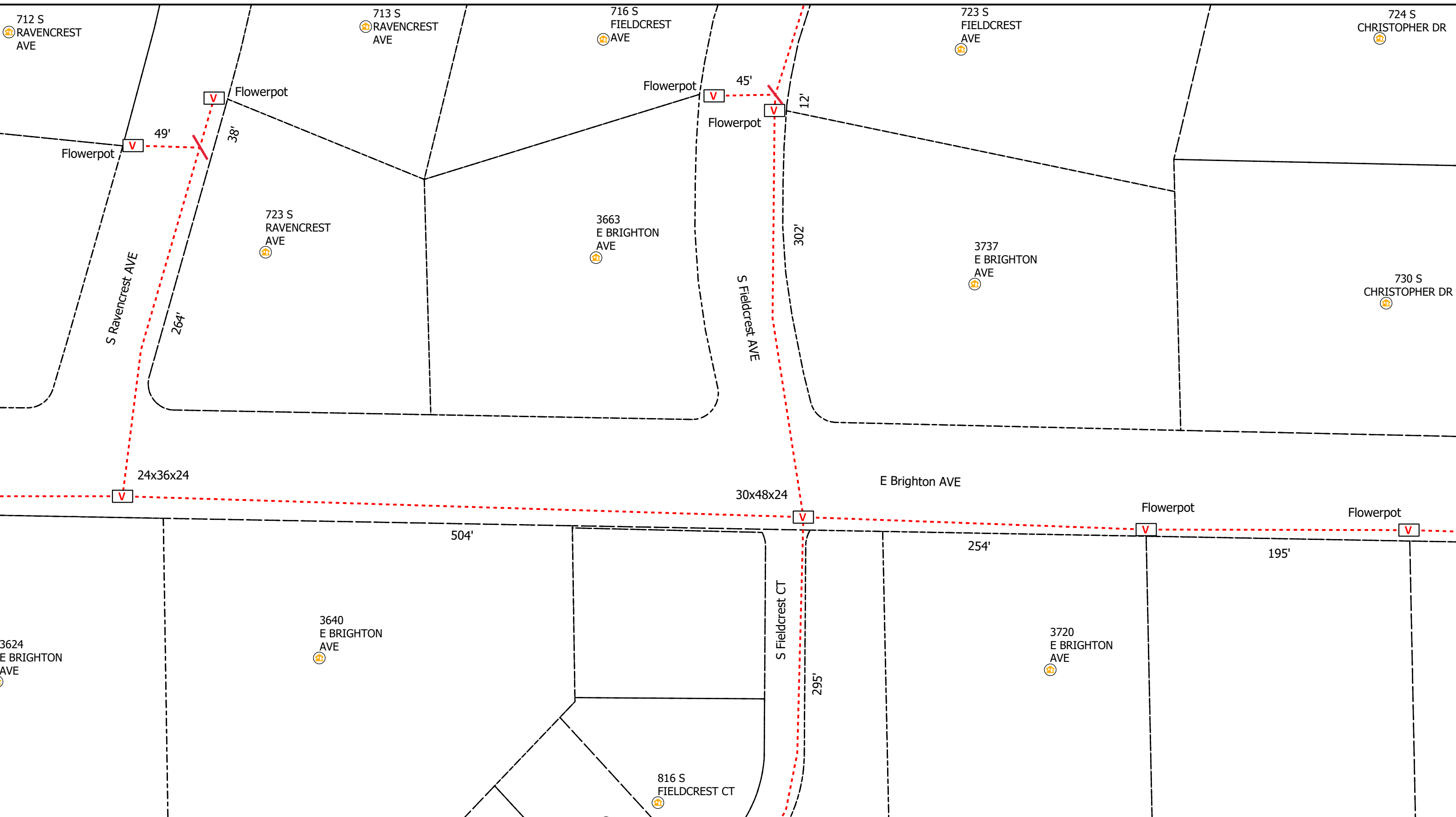

Legend

- V Vaults
- Conduit
- Bloomington_Parcel
- Poles
- 🏠 Address
- Grids
- Overhead Strand
- Other Jurisdiction

All Flowerpots 12" DIA

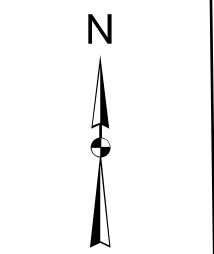

City of Bloomington, IN Permit:
Design View

INI	BY	DATE	DESCRIPTION



Legend

- Vaults
- Conduit
- Bloomington_Parcels
- Poles
- Address
- Grids
- Overhead Strand
- Other Jurisdiction

All Flowerpots 12" DIA

All Flowerpots 12" DIA

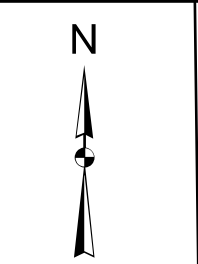

City of Bloomington, IN Permit:
Design View

INI	BY	DATE	DESCRIPTION

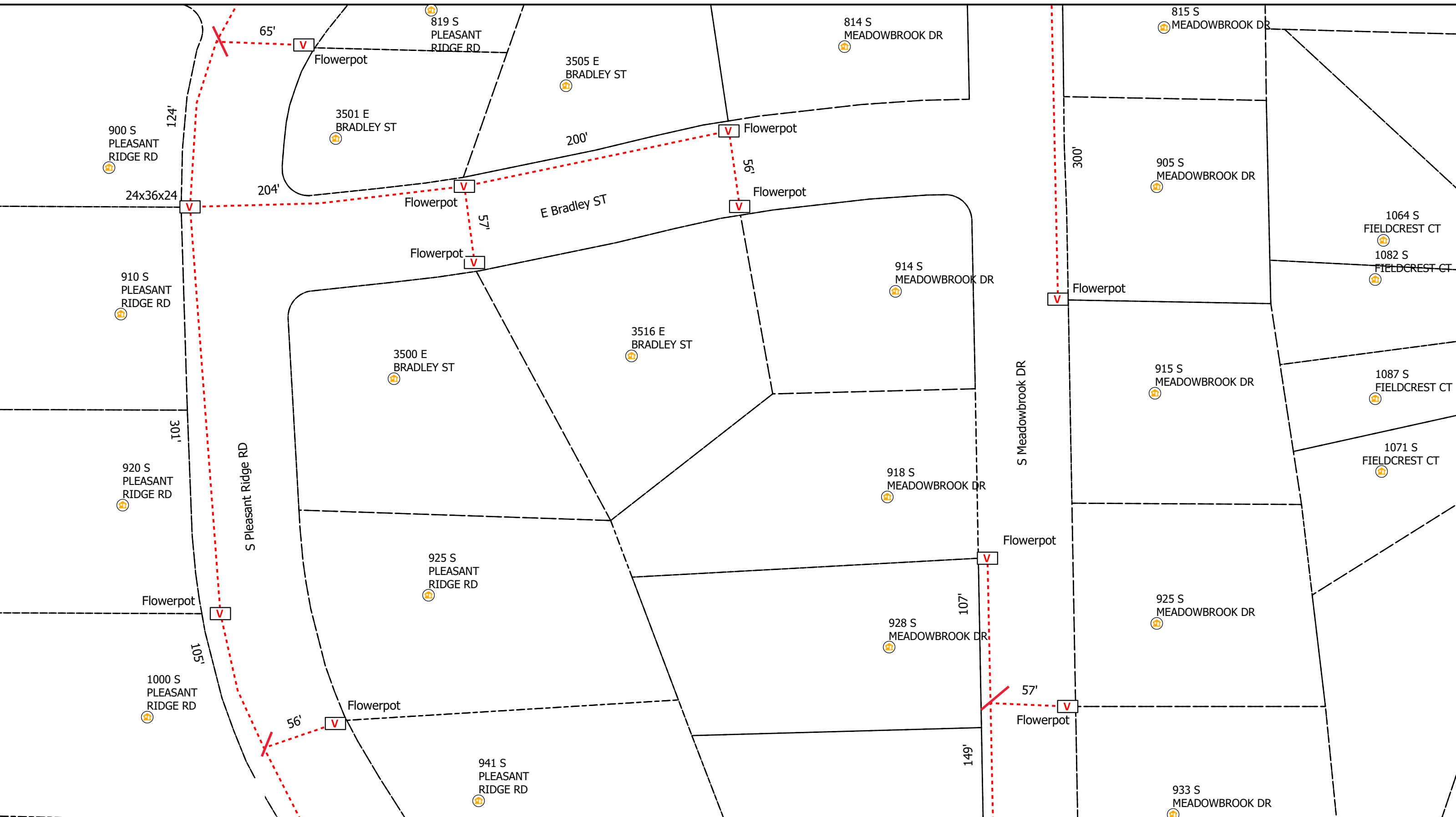

Legend

- V Vaults
- - - Conduit
- Bloomington_Parcels
- - - Other Jurisdiction
- Poles
- Ⓜ Address
- Grids
- Overhead Strand

All Flowerpots 12" DIA

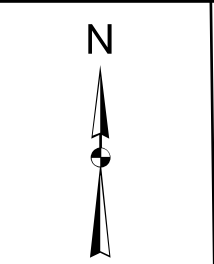

City of Bloomington, IN Permit:
Design View

INI	BY	DATE	DESCRIPTION

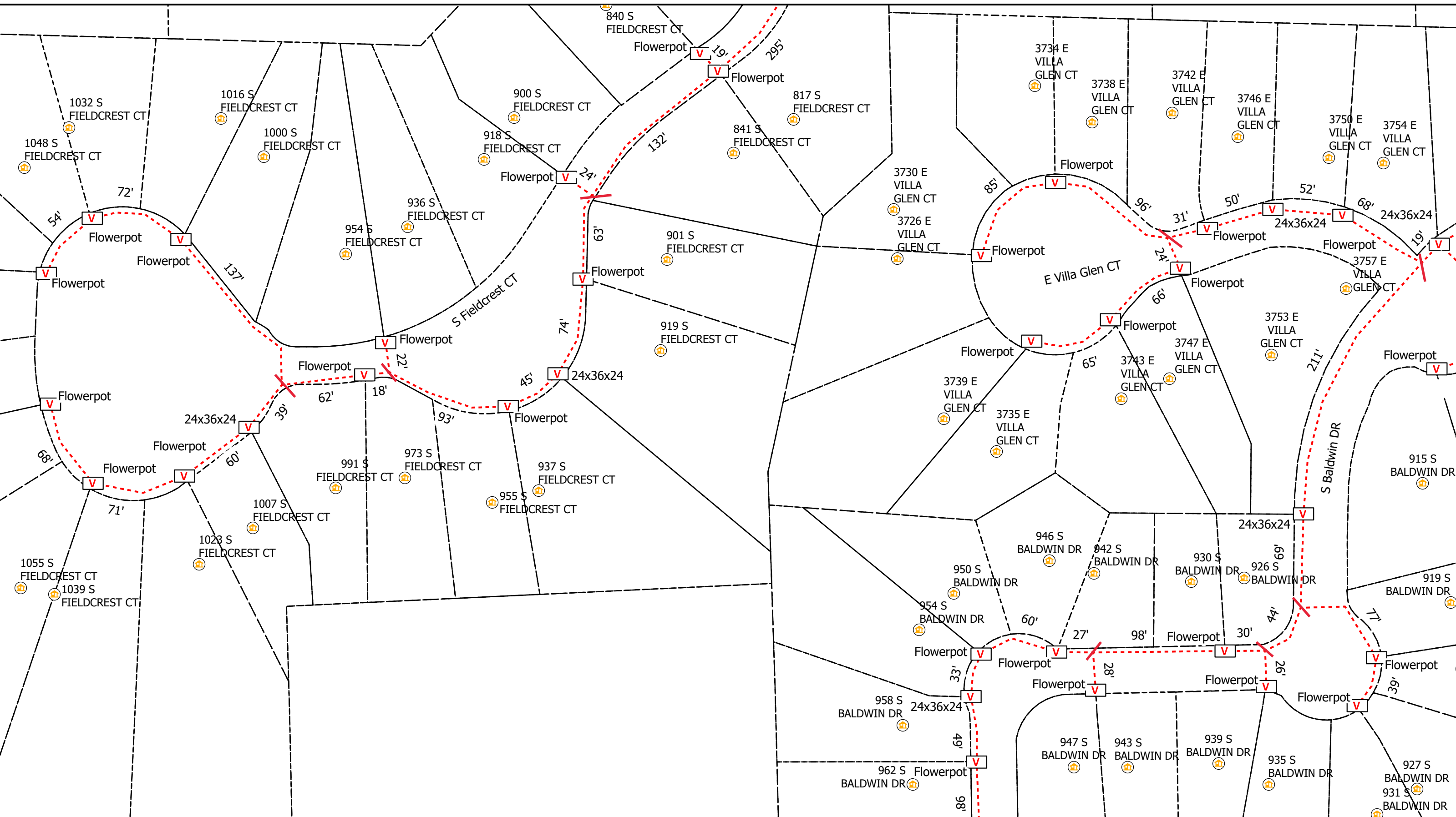

0 20 40 80 Feet

Legend

- V Vaults
- - - Conduit
- Bloomington_Parcels
- Poles
- ⊙ Address
- Grids
- Overhead Strand
- - - Other Jurisdiction

All Flowerpots 12" DIA

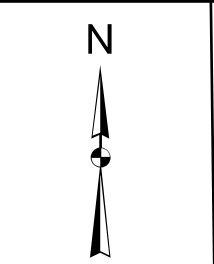

City of Bloomington, IN Permit:
Design View

INI	BY	DATE	DESCRIPTION

Print 26 of 30

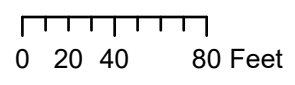
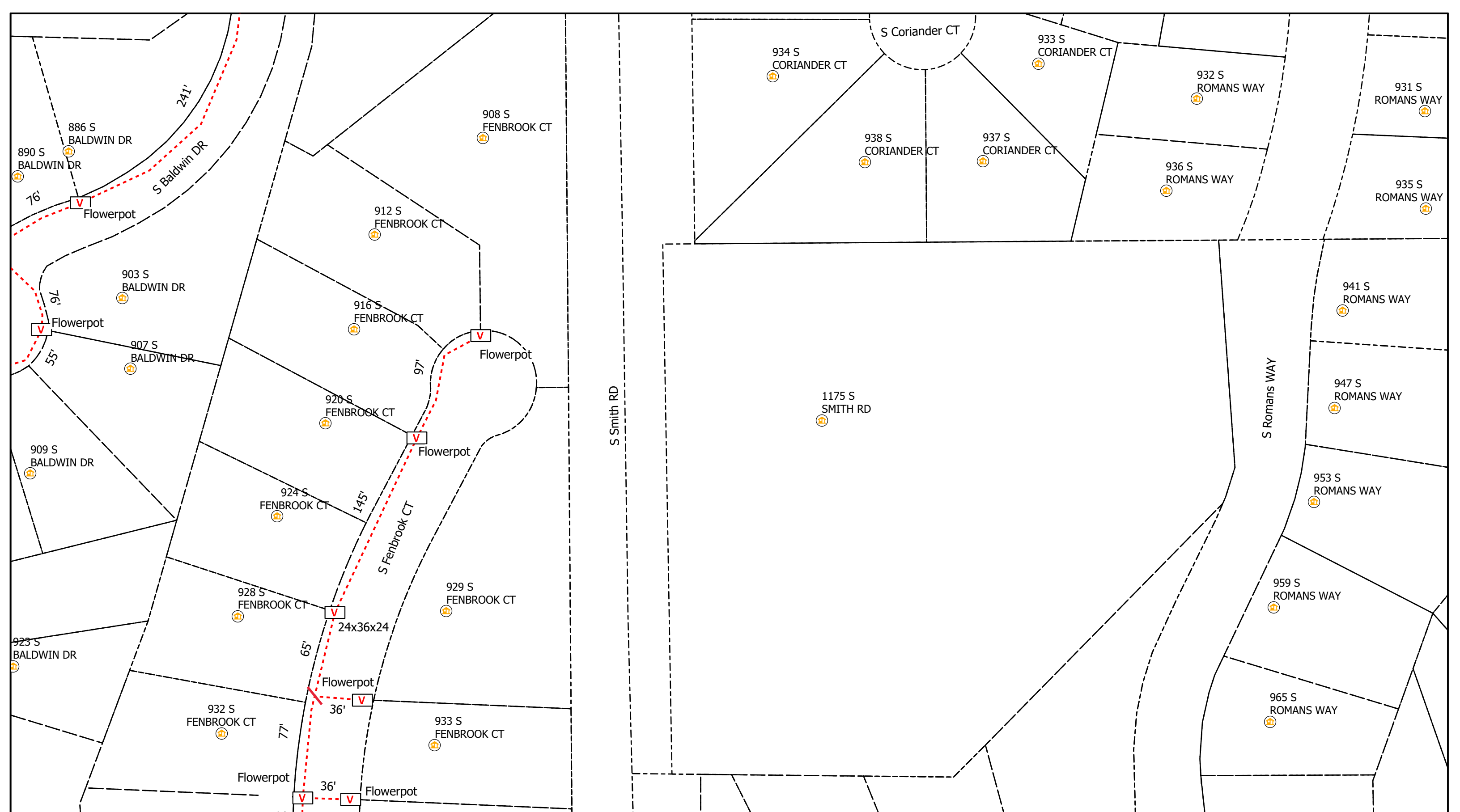

Legend

- V Vaults
- Conduit
- Bloomington_Parcels
- Poles
- Ⓜ Address
- Grids
- Overhead Strand
- Other Jurisdiction

All Flowerpots 12" DIA



City of Bloomington, IN Permit:
Design View

INI	BY	DATE	DESCRIPTION



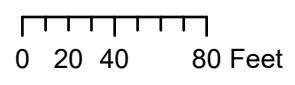
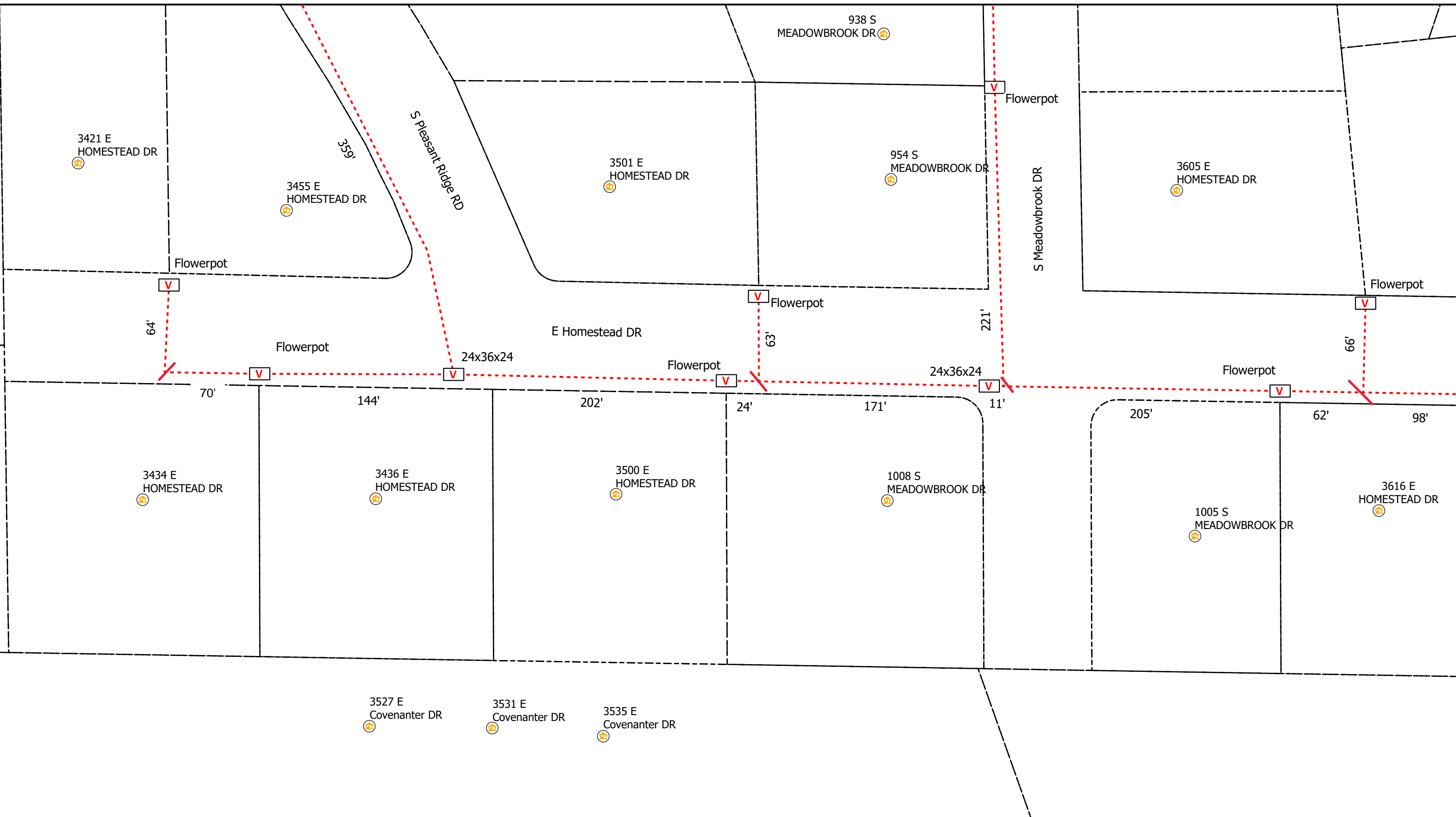

Legend

- V Vaults
- - - Conduit
- Bloomington_Parcels
- Poles
- Ⓜ Address
- Grids
- Overhead Strand
- - - Other Jurisdiction

All Flowerpots 12" DIA



City of Bloomington, IN Permit:
Design View

INI	BY	DATE	DESCRIPTION



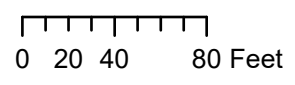
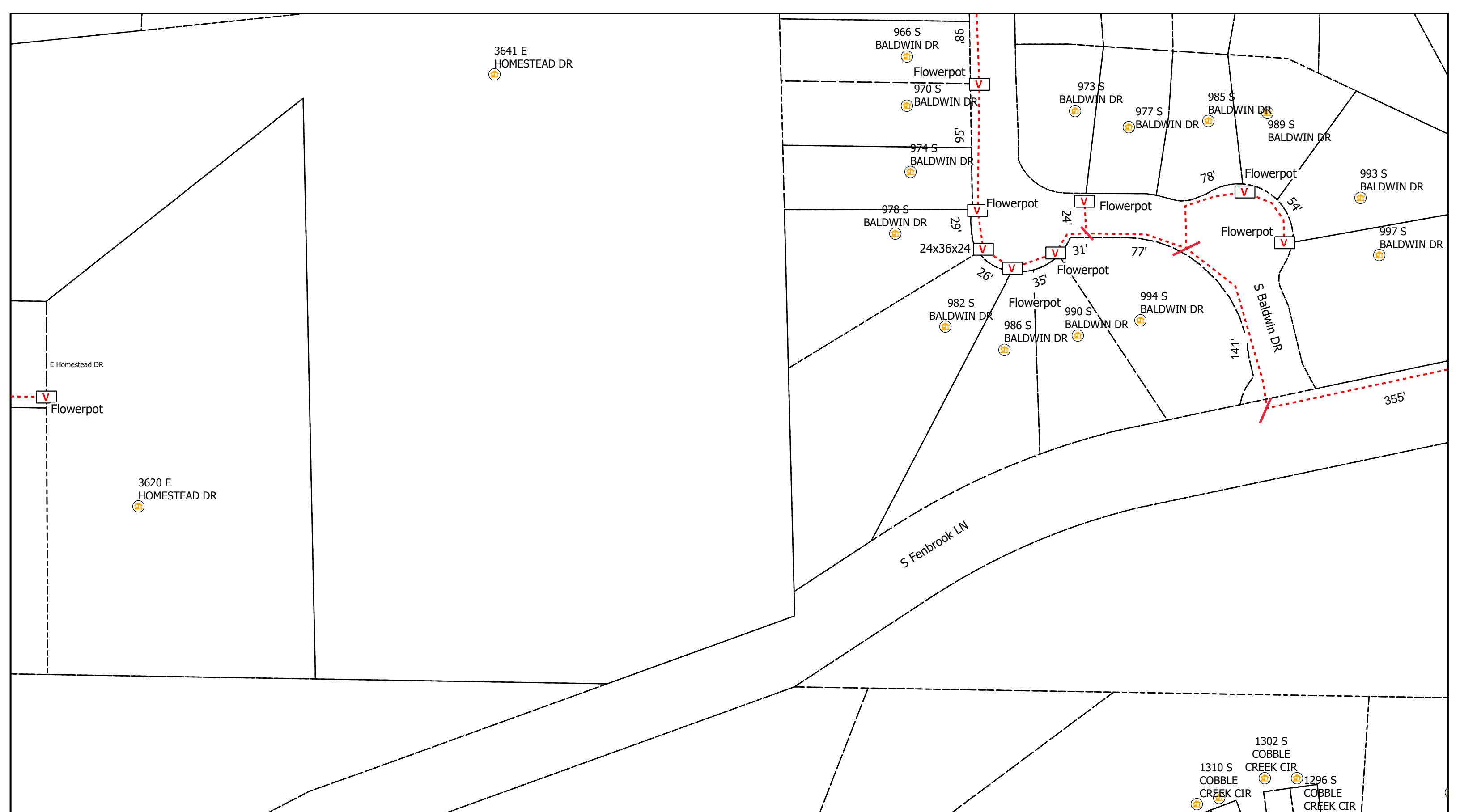

Legend

- V Vaults
- - - Conduit
- Bloomington_Parcels
- - - Other Jurisdiction
- Poles
- Ⓜ Address
- Grids
- Overhead Strand

All Flowerpots 12" DIA



City of Bloomington, IN Permit:
Design View

INI	BY	DATE	DESCRIPTION



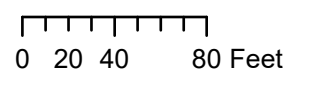
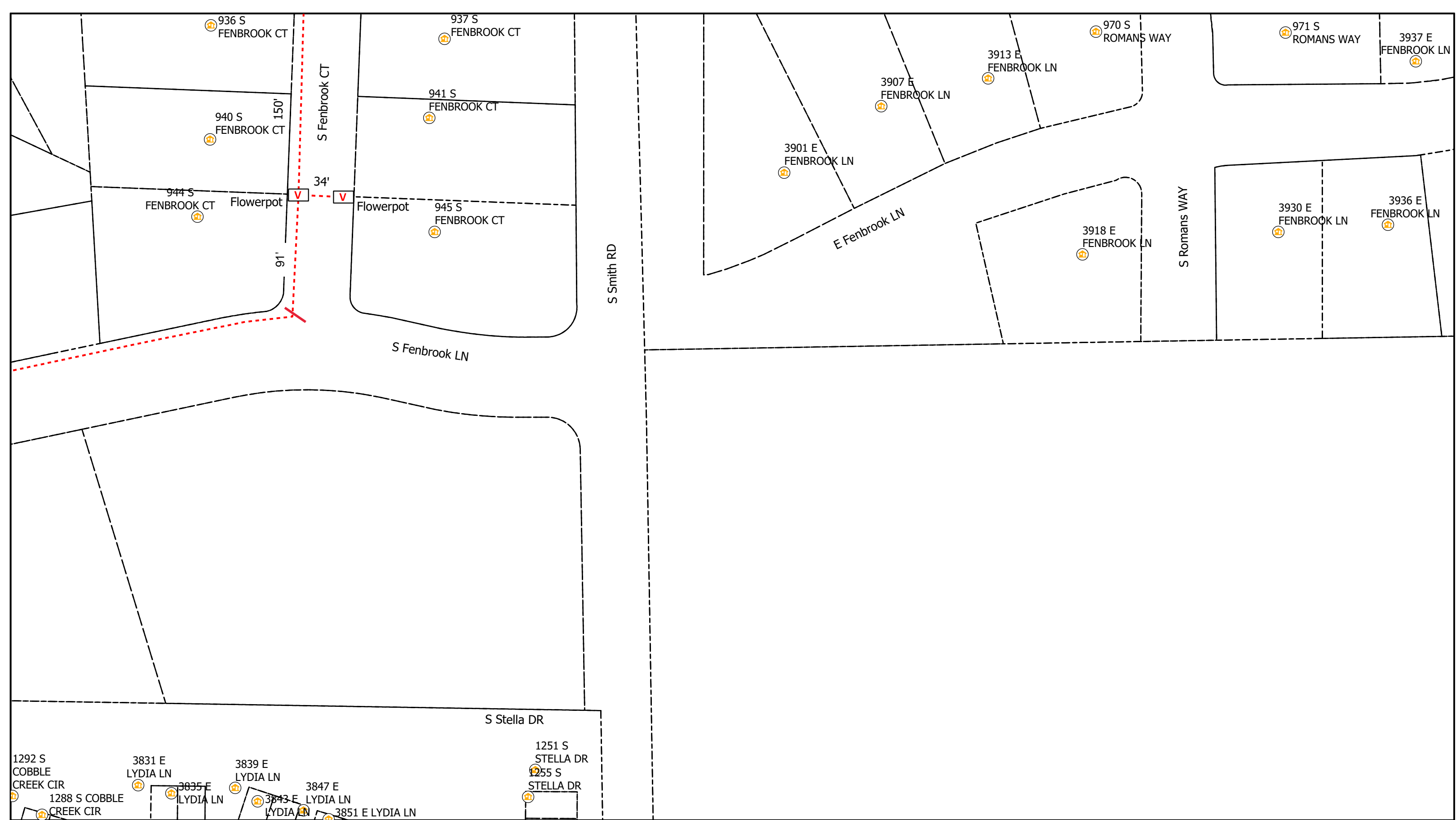

Legend

- V Vaults
- - - Conduit
- Bloomington_Parcels
- Poles
- Address
- Grids
- Overhead Strand
- - - Other Jurisdiction

All Flowerpots 12" DIA



City of Bloomington, IN Permit:
Design View

INI	BY	DATE	DESCRIPTION



Carlton® PV-Mold® Nonmetallic Pole Riser System

Carlton PV-Mold is a nonmetallic pole riser system designed to protect communications power cable installed on poles.

Features:

- Meets or exceeds requirements outlined in the National Electric Safety Code (NESC).
- Designed in accordance with NEMA TC-19 specifications.
- Ultraviolet, cold temperature and corrosive atmosphere resistant.
- Schedule 40 wall meets Schedule 80 PVC conduit impact requirements per NEMA TC-19.
- No grounding required.
- Belled end fits over each added section or conduit.
- Flame retardant.
- Requires no maintenance.
- PV-Mold acts as an insulator against electrical shock.
- Interchangeable parts and accessories to match the needs of specific requirements.



Steel U-Guard requires grounding strapping and does not have belled ends.



PV-Mold has belled ends, flanged design and does not require grounding.

Flanged Overall Length 10 Feet, Including Bell

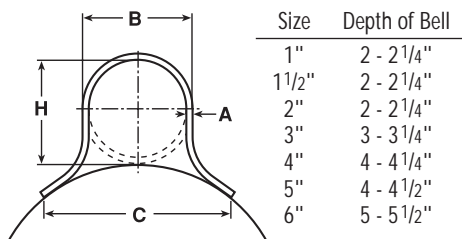

Slots are 1/2" from side to side, and allow for expansion and contraction.

Slot Dimensions: for sizes 2" through 6" are 5/16" wide, 3/4" long.

Slot Dimensions: for 1" and 1 1/2" are 3/16" wide, 3/4" long.

Slot Spacing: 18" from center, beginning 6" from end.

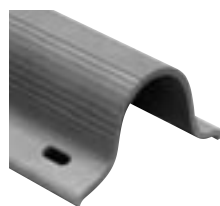

Standard Duty

Part No.	Size	Std. Ctn. Qty.	Std. Ctn. Wt. (lbs.)	Dimensions				Actual Impact @ 0°C 20 Pound Top
				A	B	C	H	
59208N	1"	294	1059	0.100"	1 5/8"	2 3/8"	1 5/8"	40 Ft.-Lbs.
59211N	2"	136	726	0.100"	2 3/8"	4 1/2"	2 3/8"	100 Ft.-Lbs.
59211X (5' length)	2"	136	363	0.100"	2 3/8"	4 1/2"	2 3/8"	100 Ft.-Lbs.
59213N	3"	66	761	0.150"	3 1/2"	6"	3 1/2"	110 Ft.-Lbs.
59213X (5' length)	3"	66	381	0.150"	3 1/2"	6"	3 1/2"	100 Ft.-Lbs.
59215N	4"	65	910	0.150"	4 1/2"	6 1/2"	4 1/2"	110 Ft.-Lbs.
59216N	5"	30	515	0.150"	5 1/2"	7 1/2"	5 1/2"	110 Ft.-Lbs.

Heavy Duty Schedule 40

59010N	1 1/2"	200	1142	0.145"	1 29/32"	3 1/2"	1 29/32"	100 Ft.-Lbs.
59011N	2"	136	1214	0.154"	2 3/8"	4 1/2"	2 3/8"	150 Ft.-Lbs.
59013N	3"	66	937	0.216"	3 1/2"	6"	3 9/32"	150 Ft.-Lbs.
59015N	4"	65	1621	0.237"	4 1/2"	6 1/2"	4 1/2"	260 Ft.-Lbs.
59015X (5' length)	4"	65	707	0.237"	4 1/2"	6 1/2"	4 1/2"	260 Ft.-Lbs.
59016N	5"	30	870	0.258"	5 1/2"	7 1/2"	5 1/2"	260 Ft.-Lbs.
59017N	6"	30	1160	0.280"	6 5/8"	8 3/4"	6 5/8"	260 Ft.-Lbs.

Extra Heavy Duty Schedule 80

59411N	2"	136	1549	0.218"	2 3/8"	4 1/2"	2 3/8"	300 Ft.-Lbs.
59413N	3"	66	1495	0.030"	3 1/2"	6"	3 1/2"	525 Ft.-Lbs.

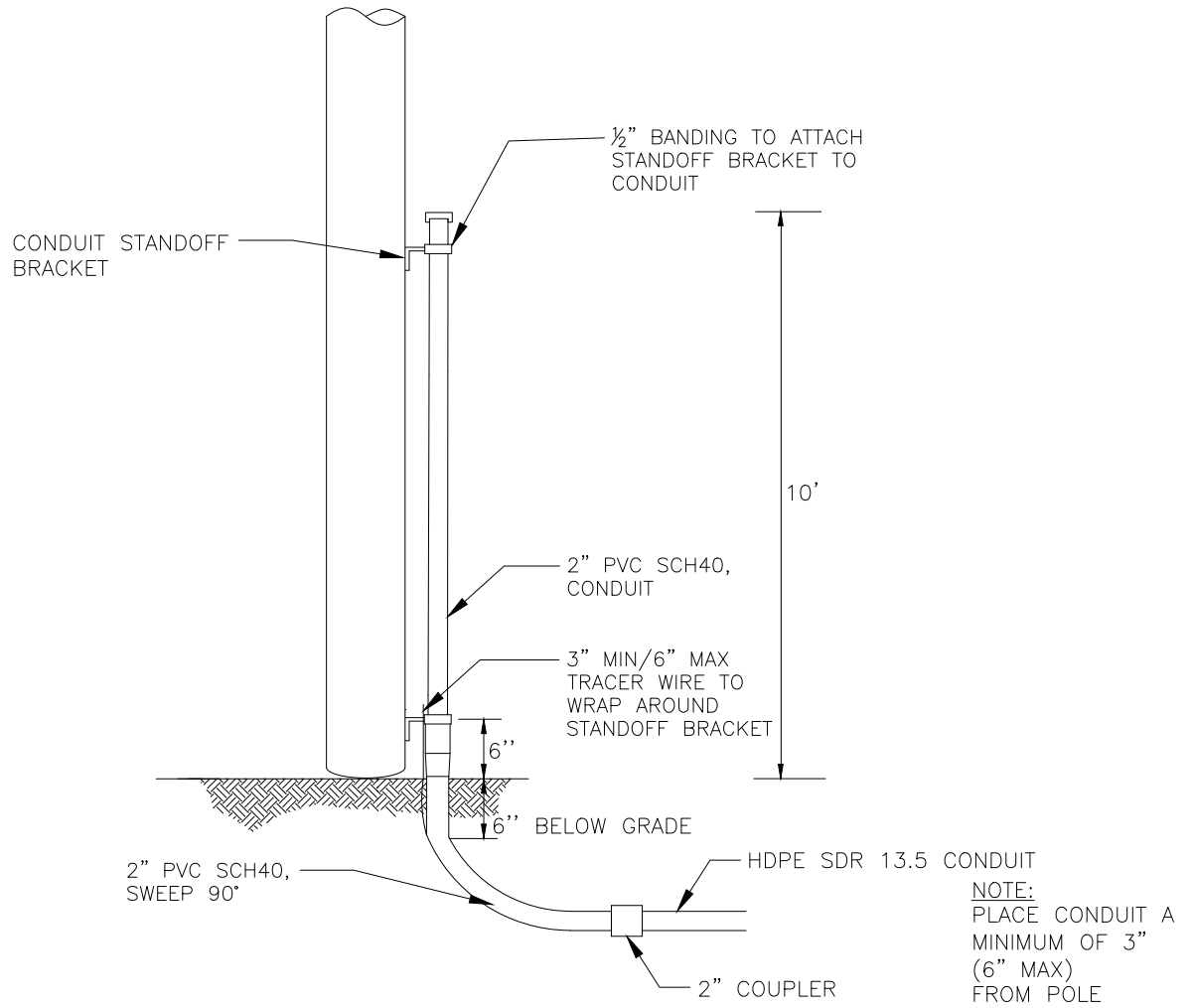

DESCRIPTION

QTY

MANUFACTURER
(PREFERRED)

PART #

SCREW, LAG, 1/2" x 4-1/2"	10		
HDPE SDR 13.5 CONDUIT, VARIOUS SIZES	N/A		
2" PVC SCH40, RISER PIPE	1		
#12 TRACER WIRE	N/A		
2" PVC SCH40, SWEEP, 90 DEG	1		
CONDUIT STANDOFF BRACKET	VARIES		
CONDUIT STRAP KIT	VARIES		
2" COUPLER	1		



TYPICAL RISER
CONDUIT
WOOD POLE

(R2-W)

CONCEPTUAL SIDE VIEW

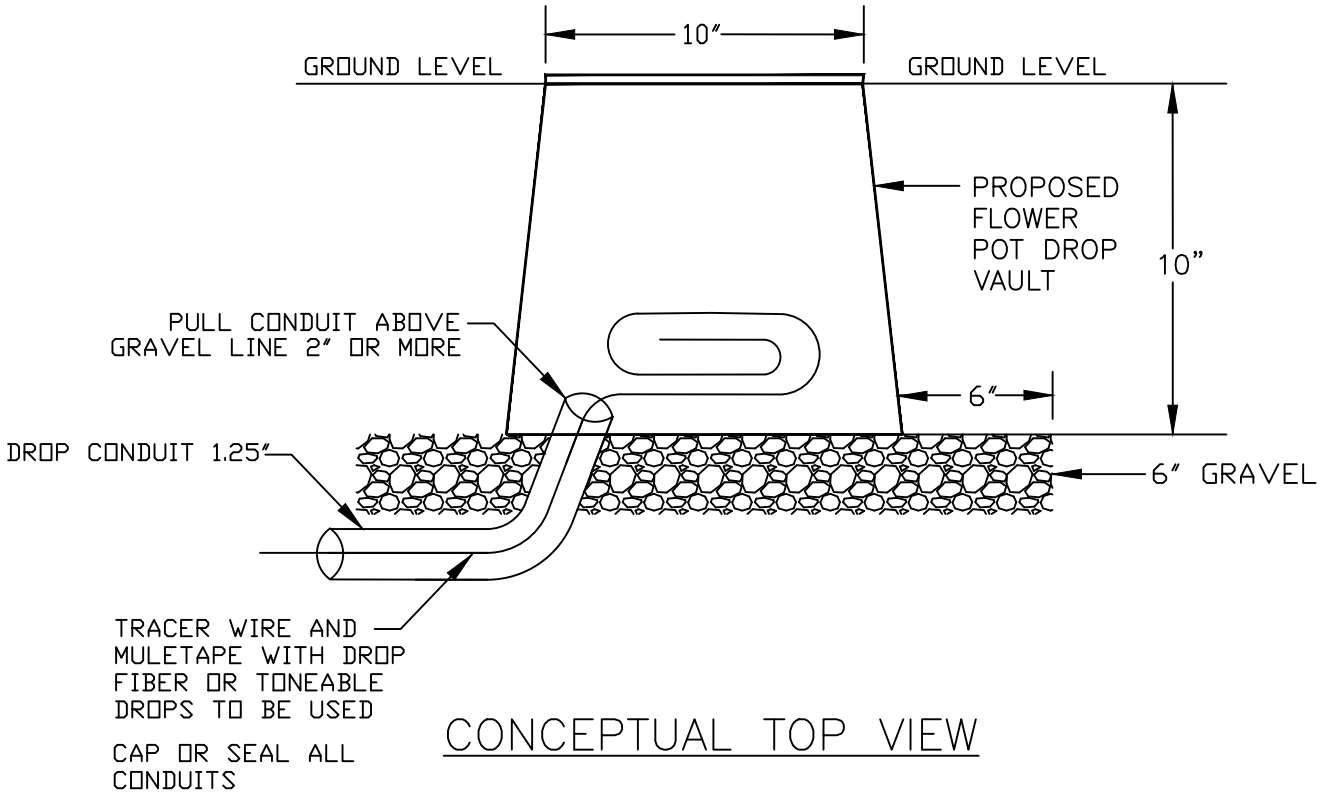

CONCEPTUAL TOP VIEW

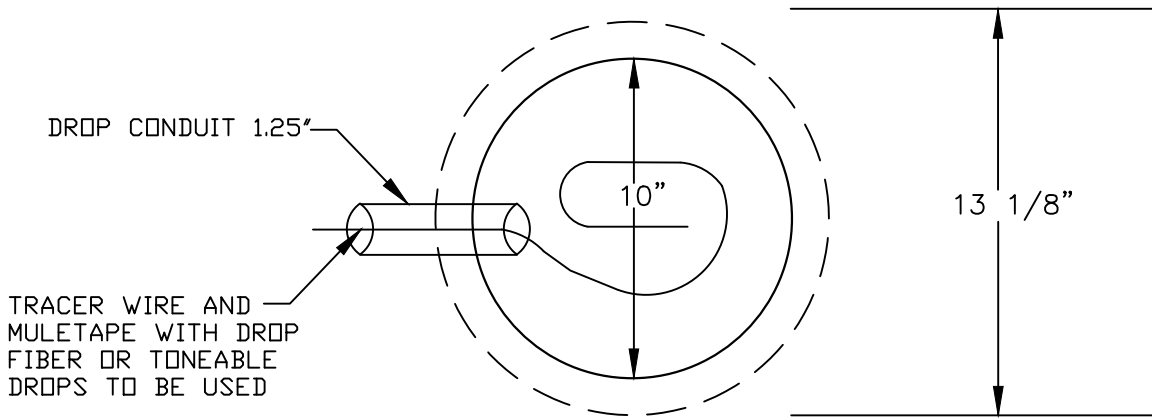

FLOWER POT

30"x48" PC UNIT, 2PC TIER 15/22
 18", 24", and 36" HEIGHT



AMERICAN POLYMER COMPANY

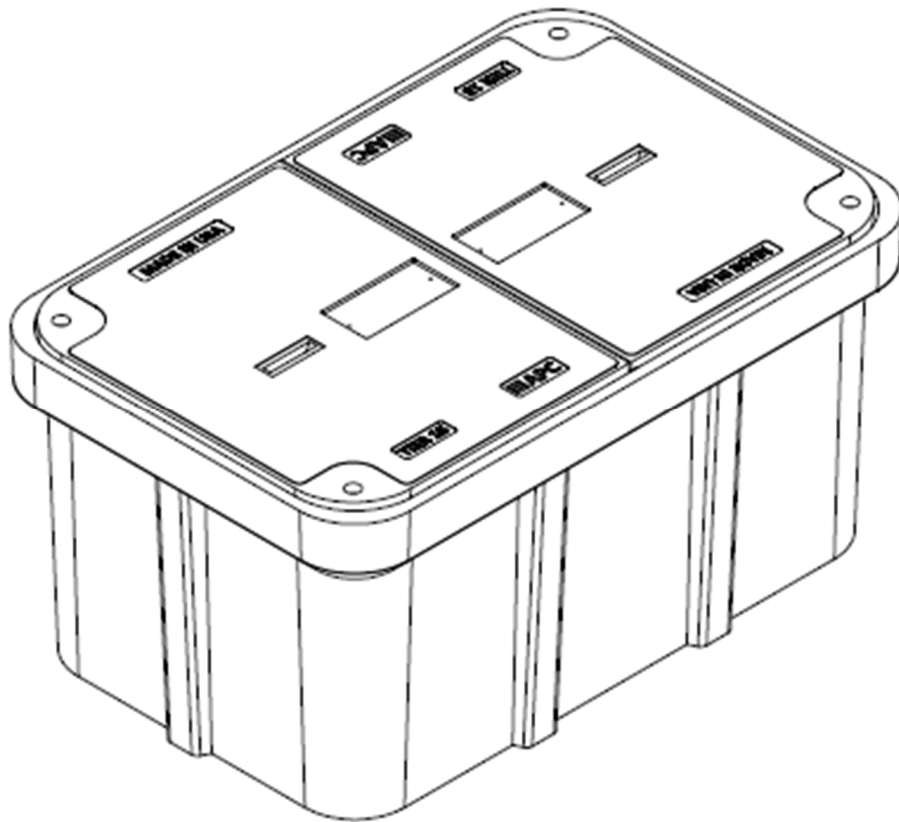

Description	Nominal Size	ANSI Tier	Part Number	Estimated Weight
PC Unit – TIER 15	30"x48"x18"	Tier 15	P304818HU15...	460 lbs.
PC Unit – TIER 22	30"x48"x18"	Tier 22	P304818HU22...	525 lbs.
PC Unit – TIER 15	30"x48"x24"	Tier 15	P304824HU15...	510 lbs.
PC Unit – TIER 22	30"x48"x24"	Tier 22	P304824HU22...	575 lbs.
PC Unit – TIER 15	30"x48"x36"	Tier 15	P304836HU15...	615 lbs.
PC Unit – TIER 22	30"x48"x36"	Tier 22	P304836HU22...	680 lbs.



30"x48" PC UNIT, 2PC TIER 15/22

18", 24", and 36" HEIGHT



AMERICAN POLYMER COMPANY

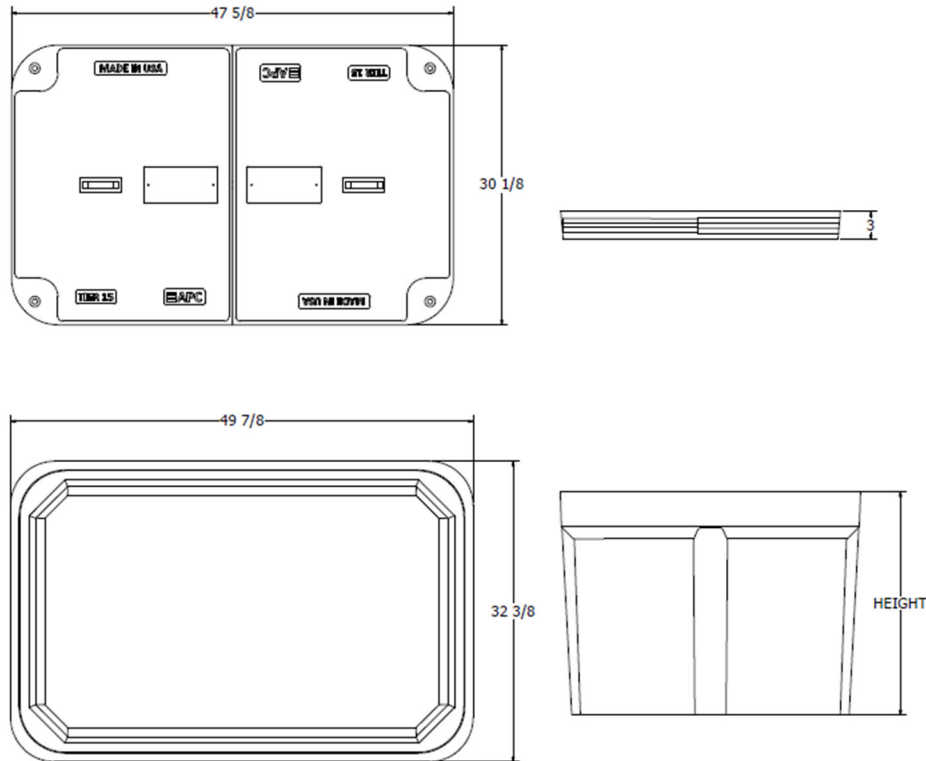

Components	Nominal Size	ANSI Tier	Part Number	Estimated Weight
Replacement Box	30"x48"x18"	Tier 22	P304818B22	185 lbs.
Replacement Box	30"x48"x24"	Tier 22	P304824B22	235 lbs.
Replacement Box	30"x48"x36"	Tier 22	P304836B22	340 lbs.
Replacement Lids - T15	30"x48" (half)	Tier 15	Various	150 lbs.
Replacement Lids - T22	30"x48" (half)	Tier 22	Various	170 lbs.

Bolt options



Machine Thread



Auger Thread



24"x36" PC UNIT, TIER 15/22
 18", 24", 30", and 36" HEIGHT



AMERICAN POLYMER COMPANY

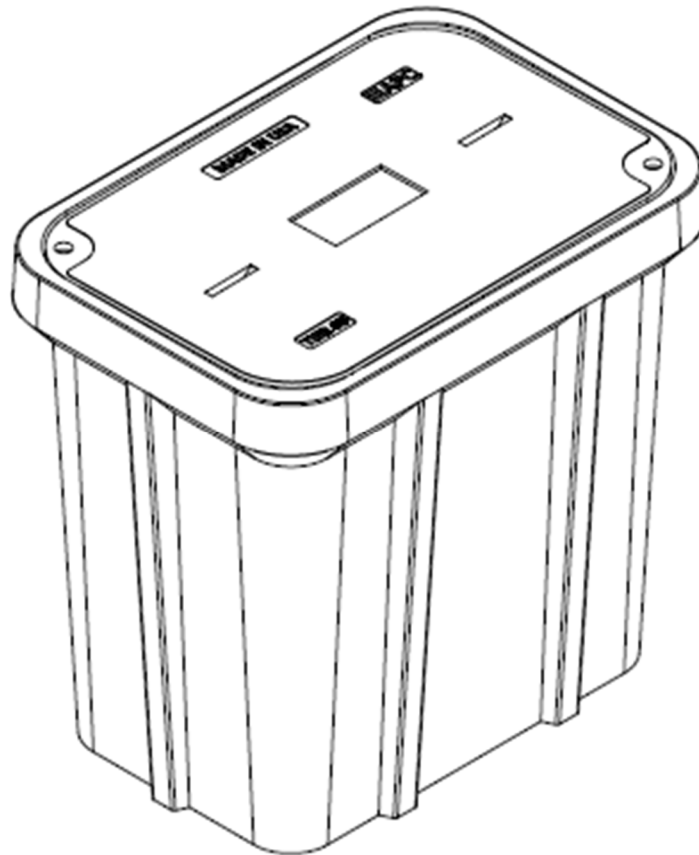

Description	Nominal Size	ANSI Tier	Part Number	Estimated Weight
PC Unit – TIER 15	24x36"x18"	Tier 15	P243618U15...	335 lbs.
PC Unit – TIER 22	24x36"x18"	Tier 22	P243618U22...	355 lbs.
PC Unit – TIER 15	24x36"x24"	Tier 15	P243624U15...	365 lbs.
PC Unit – TIER 22	24x36"x24"	Tier 22	P243624U22...	385 lbs.
PC Unit – TIER 15	24x36"x30"	Tier 15	P243630U15...	395 lbs.
PC Unit – TIER 22	24x36"x30"	Tier 22	P243630U22...	415 lbs.
PC Unit – TIER 15	24x36"x36"	Tier 15	P243636U15...	425 lbs.
PC Unit – TIER 22	24x36"x36"	Tier 22	P243636U22...	445 lbs.



24"x36" PC UNIT, TIER 15/22

18", 24", 30", and 36" HEIGHT



AMERICAN POLYMER COMPANY

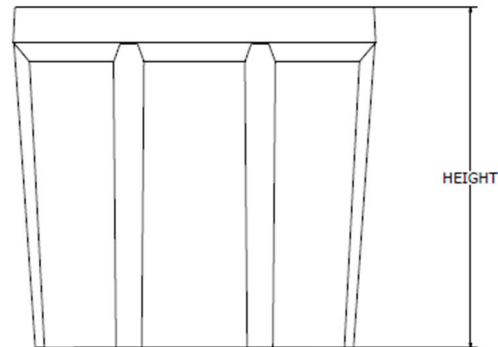
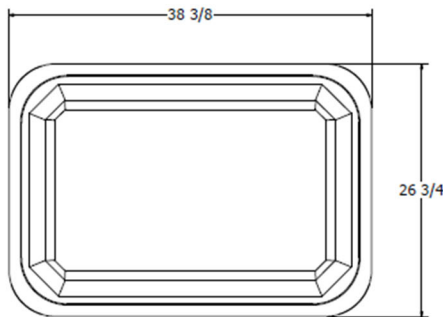
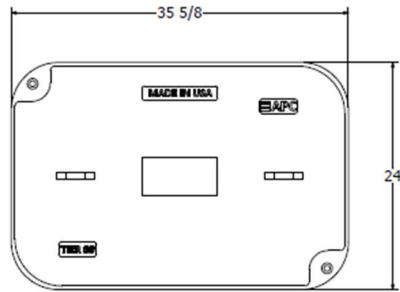

Components	Nominal Size	ANSI Tier	Part Number	Estimated Weight
Replacement Box	24"x36"x18"	Tier 22	P243618B22	165 lbs.
Replacement Box	24"x36"x24"	Tier 22	P243624B22	195 lbs.
Replacement Box	24"x36"x30"	Tier 22	P243630B22	225 lbs.
Replacement Box	24"x36"x36"	Tier 22	P243636B22	255 lbs.
Replacement Lids - T15	24"x36"	Tier 15	Various	170 lbs.
Replacement Lids - T22	24"x36"	Tier 22	Various	190 lbs.

Bolt options

Hex Head



Machine Thread



Penta Head



Auger Thread



17"x30" PC UNIT, TIER 15/22

12", 18", 24", and 30" HEIGHT



AMERICAN POLYMER COMPANY

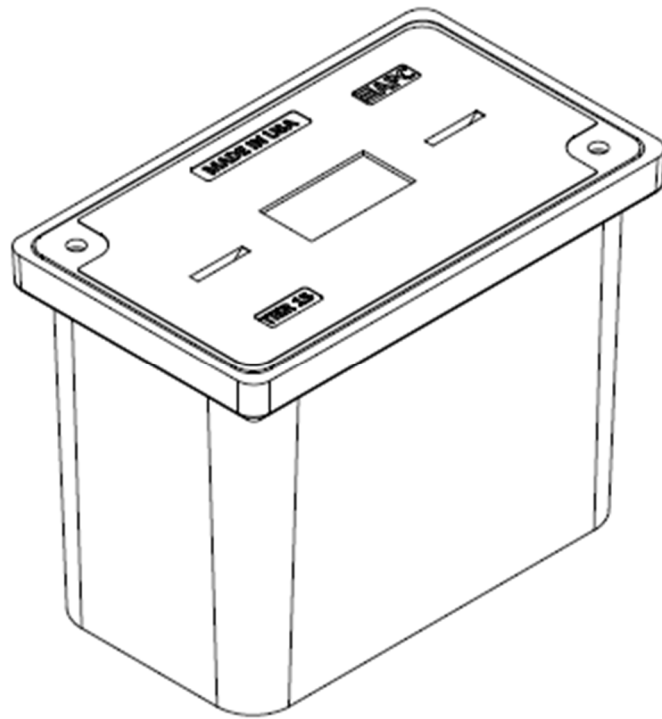

Description	Nominal Size	ANSI Tier	Part Number	Estimated Weight
PC Unit – TIER 15	17"x30"x12"	Tier 15	P173012U15...	138 lbs.
PC Unit – TIER 22	17"x30"x12"	Tier 22	P173012U22...	147 lbs.
PC Unit – TIER 15	17"x30"x18"	Tier 15	P173018U15...	172 lbs.
PC Unit – TIER 22	17"x30"x18"	Tier 22	P173018U22...	181 lbs.
PC Unit – TIER 15	17"x30"x24"	Tier 15	P173024U15...	192 lbs.
PC Unit – TIER 22	17"x30"x24"	Tier 22	P173024U22...	201 lbs.
PC Unit – TIER 15	17"x30"x30"	Tier 15	P173030U15...	217 lbs.
PC Unit – TIER 22	17"x30"x30"	Tier 22	P173030U22...	226 lbs.



17"x30" PC UNIT, TIER 15/22

12", 18", 24", and 30" HEIGHT



AMERICAN POLYMER COMPANY

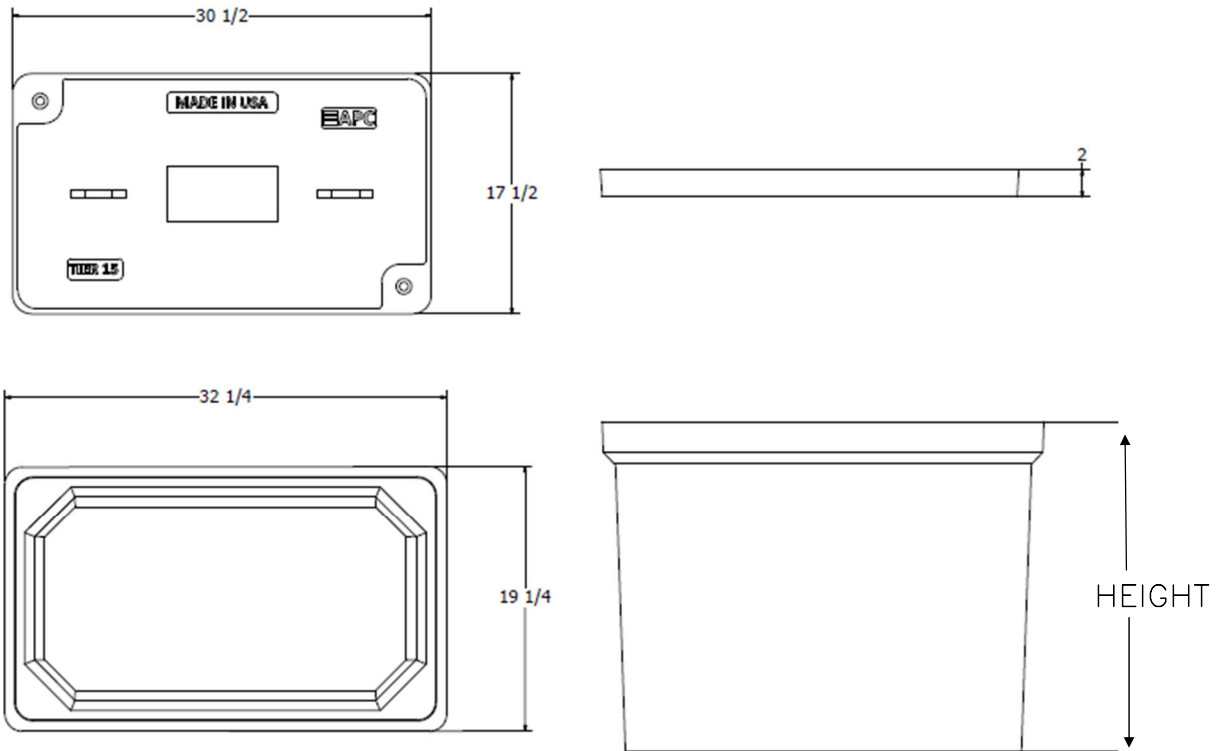

Components	Nominal Size	ANSI Tier	Part Number	Estimated Weight
Replacement Box	17"x30"X12"	Tier 22	P173012B22	66 lbs.
Replacement Box	17"x30"X18"	Tier 22	P173018B22	100 lbs.
Replacement Box	17"x30"X24"	Tier 22	P173024B22	120 lbs.
Replacement Box	17"x30"X30"	Tier 22	P173030B22	145 lbs.
Replacement Lids – T15	17"x30"	Tier 15	Various	72 lbs.
Replacement Lids – T22	17"x30"	Tier 22	Various	81 lbs.

Bolt options



Machine Thread



Auger Thread



33"x60" PC UNIT, 2PC TIER 15/22
36" HEIGHT



AMERICAN POLYMER COMPANY

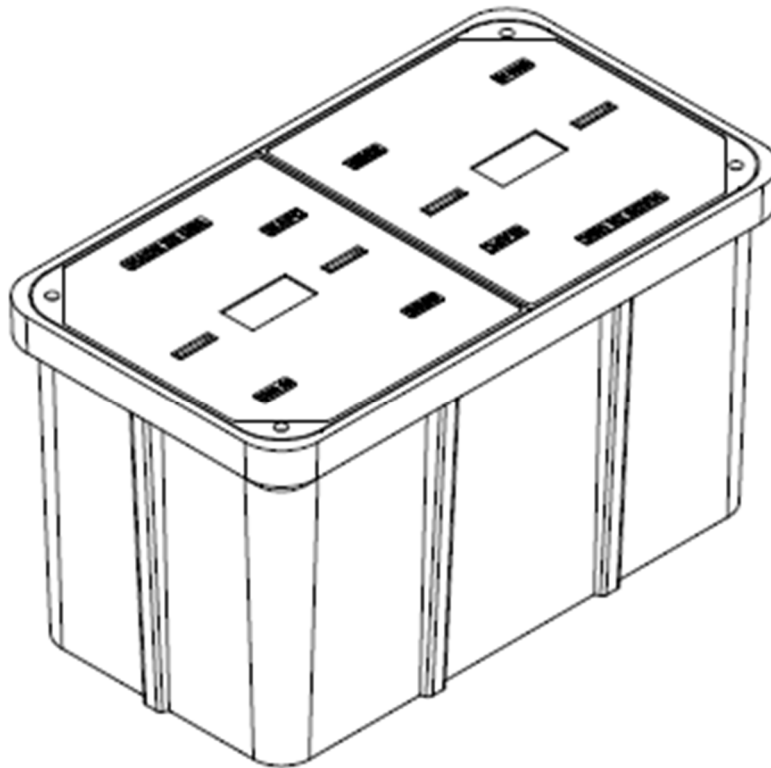

Description	Nominal Size	ANSI Tier	Part Number	Estimated Weight
PC Unit - TIER 15	33"x60"x36"	Tier 15	P336036U15...	930 lbs.
PC Unit - TIER 22	33"x60"x36"	Tier 22	P336036U22...	1030 lbs.



33"x60" PC UNIT, 2PC TIER 15/22

36" HEIGHT



AMERICAN POLYMER COMPANY

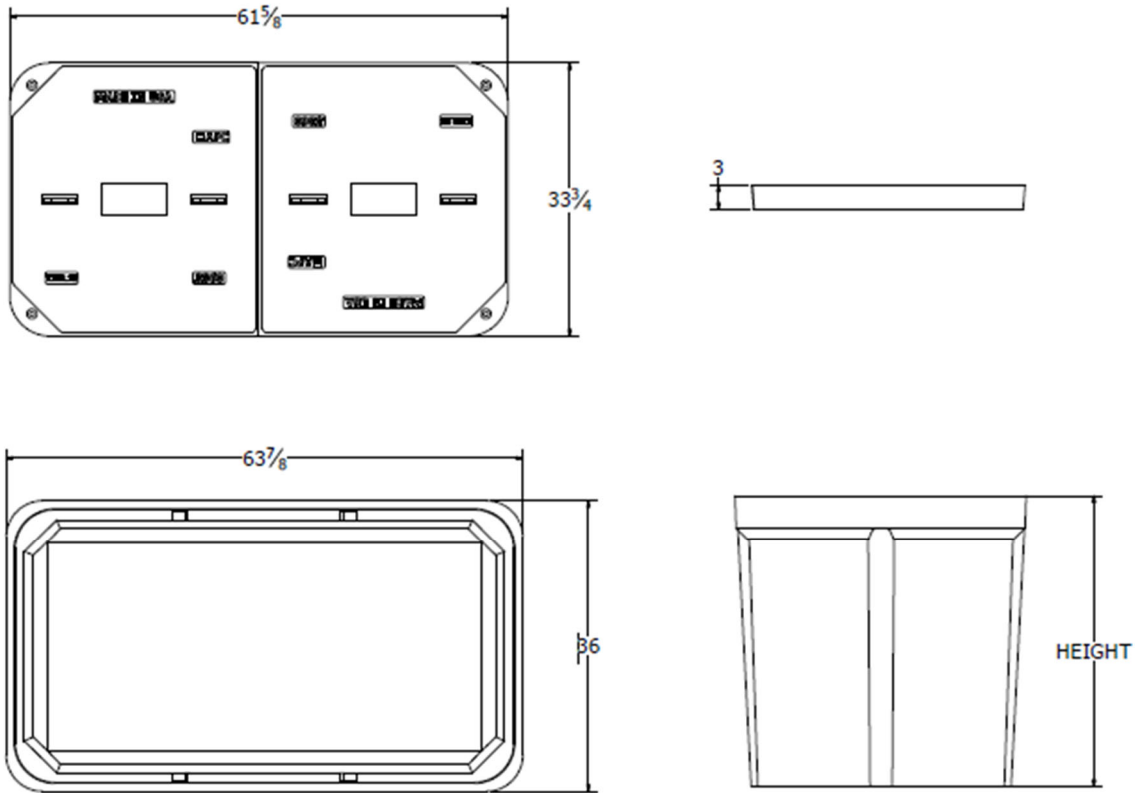

Components	Nominal Size	ANSI Tier	Part Number	Estimated Weight
Replacement Box	33"x60"x36"	Tier 22	P336036B22	530 lbs.
Replacement Lids - T15	33"x60" (half)	Tier 15	Various	200 lbs.
Replacement Lids - T22	33"x60" (half)	Tier 22	Various	250 lbs.

Bolt options

Hex Head



Machine Thread



Penta Head



Auger Thread



Spacing Charts Based on MUTCD		Must be Approved by an Engineer					
Speed (MPH) Prior To Road Work	SIGN SPACING, FT.		BUFFER SPACE, FT.	TAPER LENGTH, FT.	CHANNELIZING SPACING, FT.		
	Non-Divided Highways	Divided Highways	Length	Shoulder (10 ft. Width)	Lane (12 ft. Width)	Through Taper	Through Buffer/Work Area
0-35	200	200	250	70	245	35	50
40-45	350	500	360	150	540	40	80
50-55	500	1000	495	185	660	50	100
60-70	SA-1000, SB-1500, SC-2640		730	235	840	60	120
Urban Low Speed - 100 FT							

APPROVED/ACCEPTED BY:
ENGINEER, OWNER, or PRIME CONTRACTOR
 Check for Notice to Proceed.
BLC01b-F19 - N Glenwood Ave W - TCP

Signature: _____

Company: _____



Date: 10/3/2022 Project: BLC01b-F19 - N Glenwood Ave W - TCP :
Traffic Control Suggestion For: AEG :
By: Road Runner Safety Services, Inc. : Nathan

Comments:
Drawing not to scale. Traffic control plan must be approved by an engineer. This is a suggestion only. Road Runners Safety Services, Inc. has no liability for this suggested traffic control plan. Actual placement and spacing of all traffic control devices will depend on field conditions and must conform to MUTCD standards.

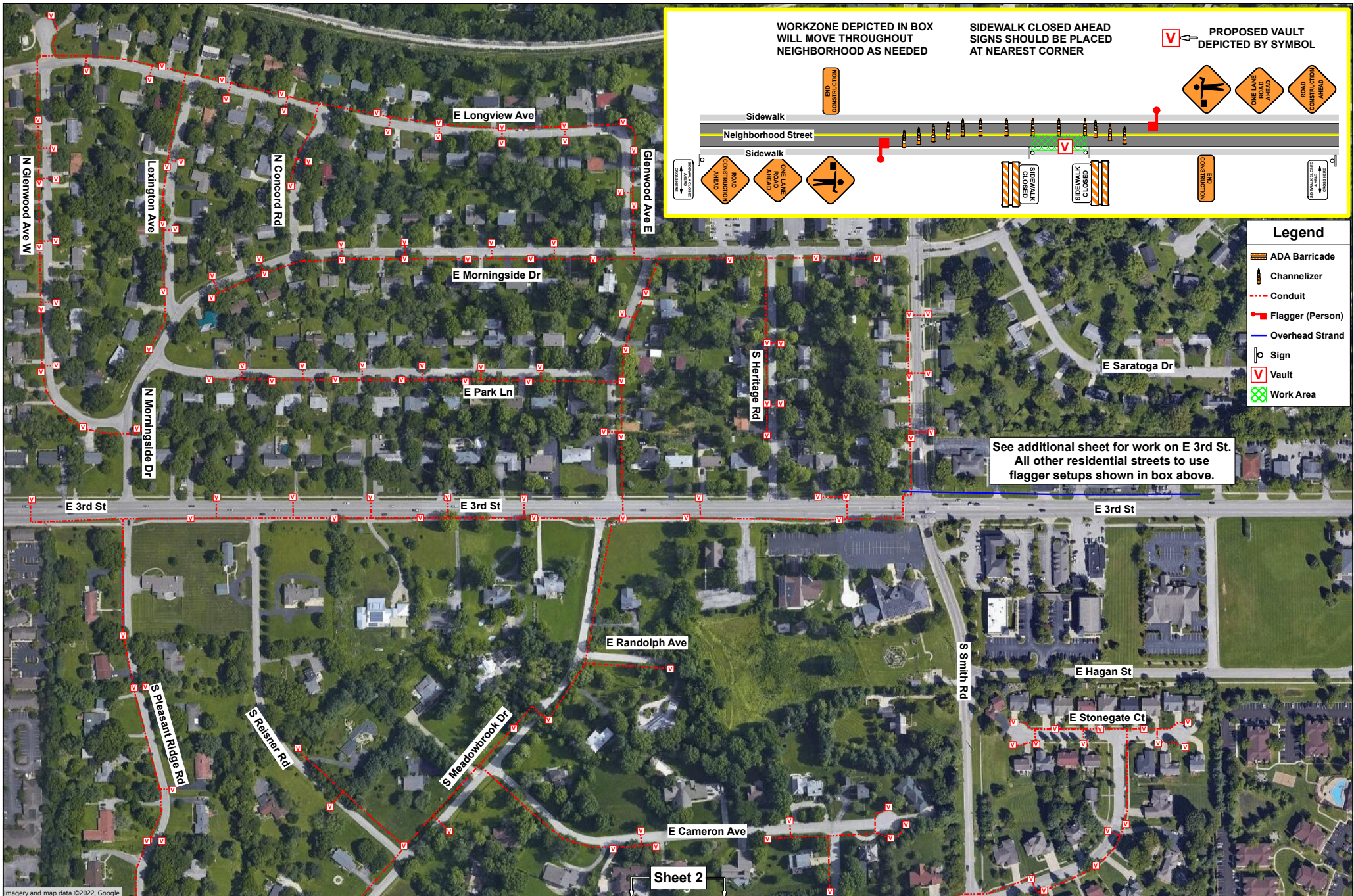

Spacing Charts Based on MUTCD			Must be Approved by an Engineer				
Speed (MPH) Prior To Road Work	SIGN SPACING, FT.		BUFFER SPACE, FT.	TAPER LENGTH, FT.	CHANNELIZING SPACING, FT.		
	Non-Divided Highways	Divided Highways	Length	Shoulder (10 ft. Wide)	Lane (12 ft. Wide)	Through Taper	Through Buffer/Work Area
0-35	200	200	250	70	245	35	50
40-45	350	500	360	150	540	40	80
50-55	500	1000	495	185	660	50	100
60-70	SA-1000, SB-1500, SC-2640		730	235	840	60	120
Urban Low Speed - 100 FT							

APPROVED/ACCEPTED BY:
ENGINEER, OWNER, or PRIME CONTRACTOR
 Check for Notice to Proceed.
BLC01b-F19 - N Glenwood Ave W - TCP

Signature: _____

Company: _____

Road Runner
Safety Services, Inc.

Date: 10/3/2022 Project: BLC01b-F19 - N Glenwood Ave W - TCP :
Traffic Control Suggestion For: AEG :
By: Road Runner Safety Services, Inc. : Nathan

Comments:
Drawing not to scale. Traffic control plan must be approved by an engineer. This is a suggestion only. Road Runners Safety Services, Inc. has no liability for this suggested traffic control plan. Actual placement and spacing of all traffic control devices will depend on field conditions and must conform to MUTCD standards.

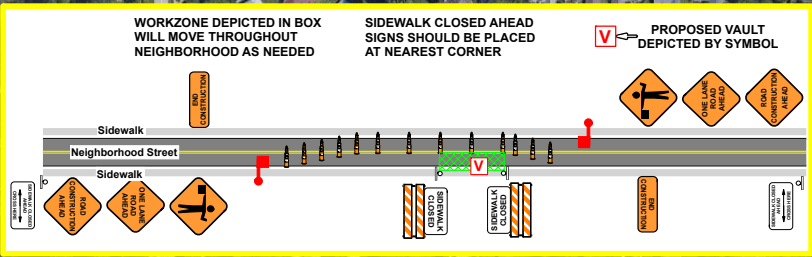
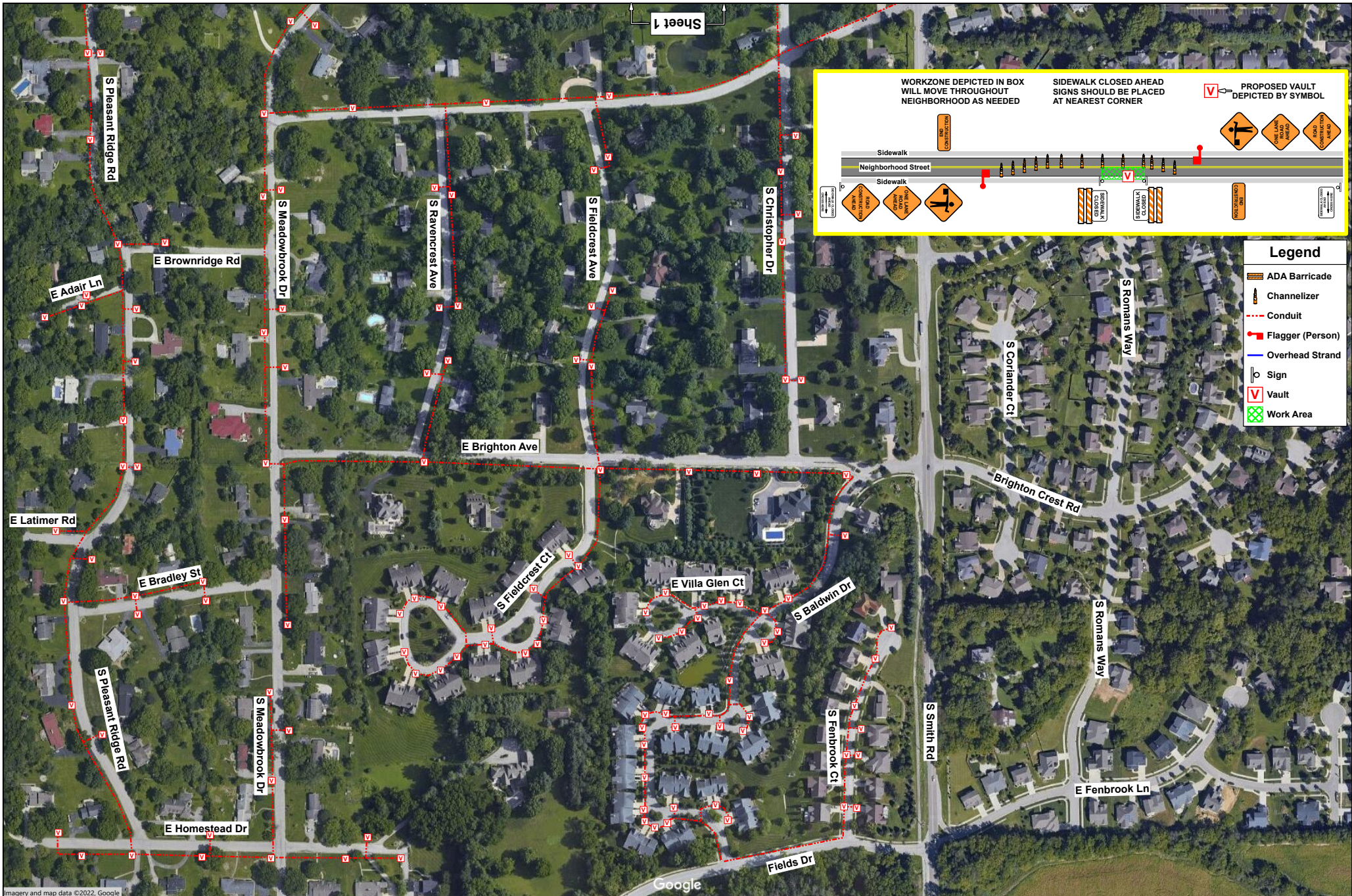

- Legend**
- ADA Barricade
 - Channelizer
 - Conduit
 - Flagger (Person)
 - Overhead Strand
 - Sign
 - Vault
 - Work Area

Spacing Charts Based on MUTCD		Must be Approved by an Engineer					
Speed (MPH) Prior To Road Work	SIGN SPACING, FT.		BUFFER SPACE, FT.	TAPER LENGTH, FT.		CHANNELIZING SPACING, FT.	
	Non-Divided Highways	Divided Highways	Length	Shoulder (10 ft Width)	Lane (12 ft Width)	Through Taper	Through Buffer/Work Area
0-35	200	200	250	70	245	35	50
40-45	350	500	360	150	540	40	80
50-55	500	1000	495	185	660	50	100
60-70	SA-1000, SB-1500, SC-2640		730	235	840	60	120
Urban Low Speed - 100 FT							

APPROVED/ACCEPTED BY:
ENGINEER, OWNER, or PRIME CONTRACTOR
 Check for Notice to Proceed.
BLC01b-F19 - N Glenwood Ave W - TCP

Signature: _____
Company: _____



Date: 10/3/2022 Project: BLC01b-F19 - N Glenwood Ave W - TCP :
: **Traffic Control Suggestion For:** AEG :
By: Road Runner Safety Services, Inc. : Nathan

Comments:
Drawing not to scale. Traffic control plan must be approved by an engineer. This is a suggestion only. Road Runners Safety Services, Inc. has no liability for this suggested traffic control plan. Actual placement and spacing of all traffic control devices will depend on field conditions and must conform to MUTCD standards.

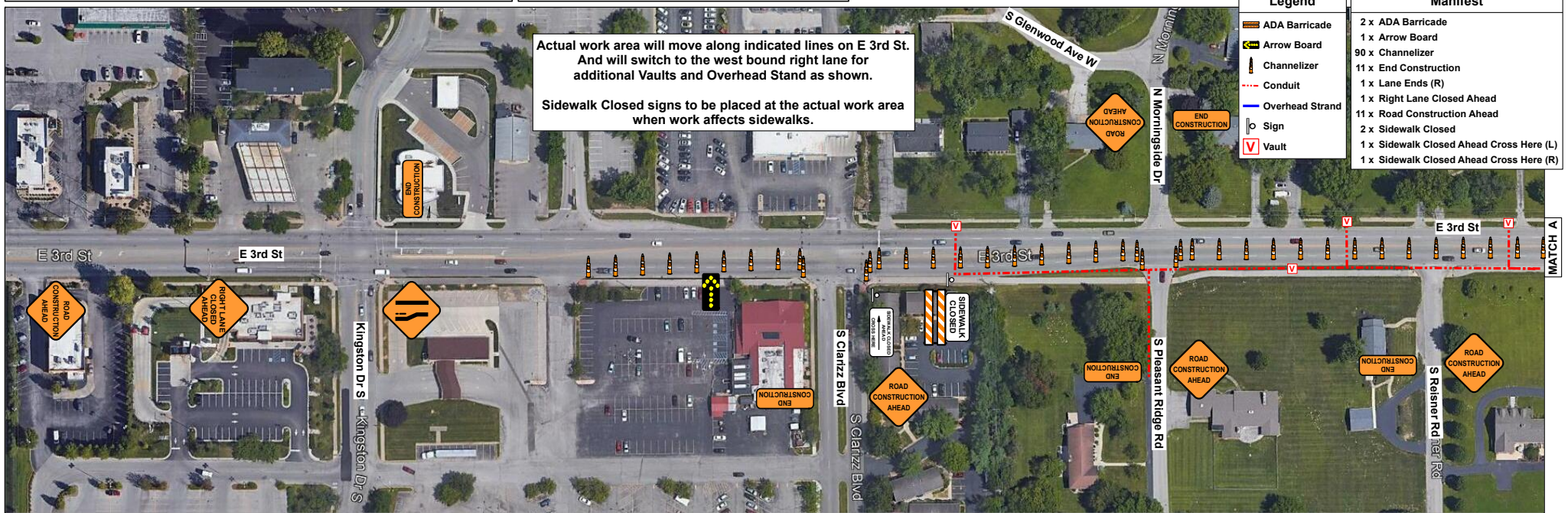

Legend	Manifest
ADA Barricade	2 x ADA Barricade
Arrow Board	1 x Arrow Board
Channelizer	90 x Channelizer
Conduit	11 x End Construction
Overhead Strand	1 x Lane Ends (R)
Sign	1 x Right Lane Closed Ahead
Vault	11 x Road Construction Ahead
	2 x Sidewalk Closed
	1 x Sidewalk Closed Ahead Cross Here (L)
	1 x Sidewalk Closed Ahead Cross Here (R)

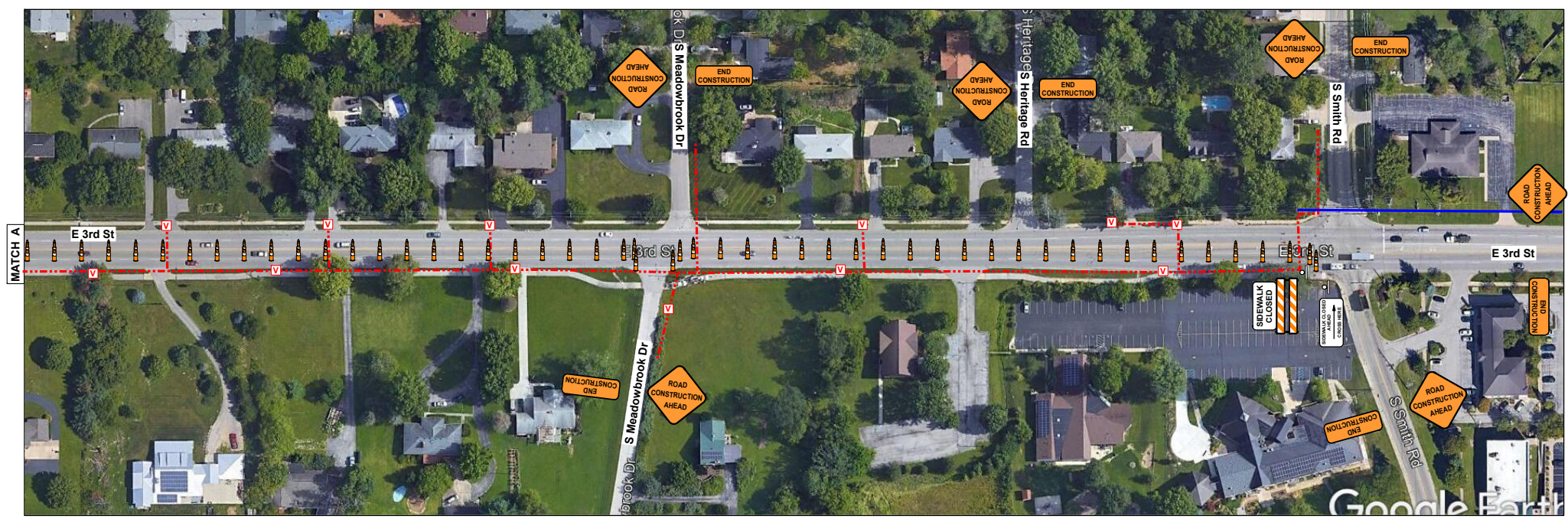



CITY OF BLOOMINGTON RIGHT-OF-WAY USE PERMIT APPLICATION

401 N Morton Street, Suite 130
P.O. Box 100
Bloomington, IN 47402

Phone: (812) 349-3913
Fax: (812) 349-3520
Email:
engineering@bloomington.in.gov

ROW EXCAVATION ROW USE

ADDRESS OF ROW ACTIVITY: _____

A. APPLICANT/AGENT INFORMATION: APPLICANT NAME: _____ E-MAIL: _____ COMPANY: _____ ADDRESS: _____ CITY, STATE, ZIP: _____ 24-HR EMERGENCY CONTACT NAME: _____ 24-HR CONTACT PHONE #: _____ INSURANCE #*: 883724951 COMPANY: ACORD BOND#*: _____ COMPANY: _____ <small>* INSURANCE & BOND MUST BE ON FILE WITH THE CITY BEFORE PERMIT WILL BE ISSUED</small>	D. TRAFFIC CONTROL DEVICES*: <input type="checkbox"/> CONES <input type="checkbox"/> ARROWBOARD <input type="checkbox"/> LIGHTED BARRELS <input type="checkbox"/> TYPE 3 BARRICADES <input type="checkbox"/> FLAGGERS <input type="checkbox"/> BPD OFFICER <small>*PROVIDING MUTCD COMPLIANT TEMPORARY TRAFFIC CONTROL DEVICES AND MAINTENANCE OF TRAFFIC (MOT) PLAN IS YOUR RESPONSIBILITY AND REQUIRED See page 3 for additional MOT resources; the graph paper can be used for your MOT site plan if needed or you can submit a separate sheet</small>
SUBCONTRACTOR INFORMATION (LIST ALL COMPANIES WORKING UNDER PRIMARY CONTRACTOR PERMIT) COMPANY NAME: _____	E. METERED PARKING SPACES NEEDED: <input type="checkbox"/> Y <input type="checkbox"/> N <small>IT IS THE RESPONSIBILITY OF THE APPLICANT TO RESERVE PARKING METER(S) APPLICATION LOCATED: https://bloomington.in.gov/transportation/parking/moving OR CONTACT PARKING SERVICES WITH QUESTIONS AT (812)349-3436</small>
B. WORK DESCRIPTION: <input type="checkbox"/> POD/DUMPSTER <input type="checkbox"/> CRANE <input type="checkbox"/> SCAFFOLDING <input type="checkbox"/> CONSTRUCTION USE* (EXPLAIN): _____ <small>*EXCAVATION, LONG TERM USE FOR STORAGE OF MATERIAL/EQUIPMENT/WALKAROUND</small>	F. IS THIS A <input type="checkbox"/> CBU* <input type="checkbox"/> COUNTY* <input type="checkbox"/> IU* <input type="checkbox"/> NP* PROJECT? PROJECT NAME: _____ PROJECT #: _____ PROJECT MGR.: _____ PROJECT MGR. #: _____ <small>*CBU = CITY OF BLOOMINGTON UTILITIES *COUNTY = MONROE COUNTY *IU= INDIANA UNIVERSITY *NP= NOT-FOR-PROFIT AGENCY</small>
C. RIGHT OF WAY TO BE USED/CLOSED: STREET NAME 1: _____ 1ST INTERSECTING STREET NAME: _____ 2ND INTERSECTING STREET NAME: _____ <input type="checkbox"/> ROAD CLOSURE <input type="checkbox"/> LANE CLOSURE 1 <input type="checkbox"/> 2 <input type="checkbox"/> 3 <input type="checkbox"/> <input type="checkbox"/> SIDEWALK* <input type="checkbox"/> BIKE LANE <input type="checkbox"/> OTHER TRANSIT STOP? <input type="checkbox"/> Y <input type="checkbox"/> N PARKING LANE(S)** <input type="checkbox"/> Y <input type="checkbox"/> N <small>**NON-METERED</small> START DATE: _____ END DATE: _____ # OF DAYS*: _____ STREET NAME 2: _____ 1ST INTERSECTING STREET NAME: _____ 2ND INTERSECTING STREET NAME: _____ <input type="checkbox"/> ROAD CLOSURE <input type="checkbox"/> LANE CLOSURE 1 <input type="checkbox"/> 2 <input type="checkbox"/> 3 <input type="checkbox"/> <input type="checkbox"/> SIDEWALK* <input type="checkbox"/> BIKE LANE <input type="checkbox"/> OTHER TRANSIT STOP? <input type="checkbox"/> Y <input type="checkbox"/> N PARKING LANE(S)** <input type="checkbox"/> Y <input type="checkbox"/> N <small>**NON-METERED</small> START DATE: _____ END DATE: _____ # OF DAYS*: _____ <small>*SIDEWALK CLOSURES FOR A PERIOD OR PERIODS TOTALING 24HRS OR MORE SHALL INSTALL A WALKAROUND UNLESS OTHERWISE APPROVED DURING REVIEW</small>	G. EXCAVATIONS: SQ FT OF PAVEMENT* EXCAVATIONS : _____ <small>*PAVEMENT INCLUDES: IN OR UNDER CONCRETE, OR ASPHALT INCLUDING CURBS</small> SQ FT OF NON-PAVEMENT* EXCAVATIONS: _____ <small>*DIRT, GRASS, GRAVEL, LANDSCAPE AREA OR OTHER UNPAVED SURFACE</small> LINEAL FT OF BORE*: _____ <small>*BORE PITS SHALL BE CALCULATED AS SQ FT EXCAVATIONS</small> # OF POLE INSTALLATIONS/REMOVAL: _____ SQ FT OF SIDEWALK RECONSTRUCTION*: _____ <small>*CONCRETE OR ASPHALT SIDEWALK/PATH BEING IMPROVED/REPLACED</small> SQ FT OF SIDEWALK NEW CONSTRUCTION*: _____ <small>*CONCRETE OR ASPHALT SIDEWALK/PATH THAT IS NEW INFRASTRUCTURE</small> #RESIDENTIAL DRIVEWAY INSTALLATION: _____
STANDARD CLOSURE HOURS MON-FRI*: 9:00 AM - 3:00 PM & 6:00 PM - 9:00 PM STANDARD CLOSURE HOURS <input type="checkbox"/> *NON-STANDARD CLOSURE HOURS <input type="checkbox"/> REQUESTED CLOSURE HOURS: _____ AM - _____ PM <small>*non-standard hours may not be allowed near schools, on arterials, or other circumstances and are subject to approval during the permitting process BMC 14.09.040 allows work from 6 AM to 10 PM without violating the noise ordinance (7AM to 9PM for pneumatic hammers)</small>	 <small>TO SUBMIT A LOCATE REQUEST 24 HRS A DAY, 7 DAYS A WEEK CALL 811 OR 800-382-5544 CALL 2 WORKING DAYS BEFORE YOU DIG. ITS THE LAW.</small>
H. INDEMNIFICATION AGREEMENT: <small>The petitioner/applicant hereby agrees to hold harmless, defend and to indemnify the City of Bloomington from or against all claims, action, damages and expenses, including but not limited to reasonable attorney's fees or any alleged injury and/or death to any person or damage to any property arising, or alleged to have arisen out of any act of commission or omission on the part of the petitioner/applicant, his/her heirs, successors, or assigns regardless of whether such acts are the direct or indirect result of the public right-of-way use pursuant to this permit grant.</small> I AFFIRM, UNDER THE PENALTIES FOR PERJURY, THAT THE FOREGOING REPRESENTATIONS ARE TRUE. PRINT NAME: _____ SIGNATURE: <u>Bret Simans</u> DATE: _____	

For Administration Use Only (applicable to CLOSURE approval)

Approved By: _____ BPW City Engineer Director Date: _____

Staff Representative: _____ Phone#: _____ Date: _____

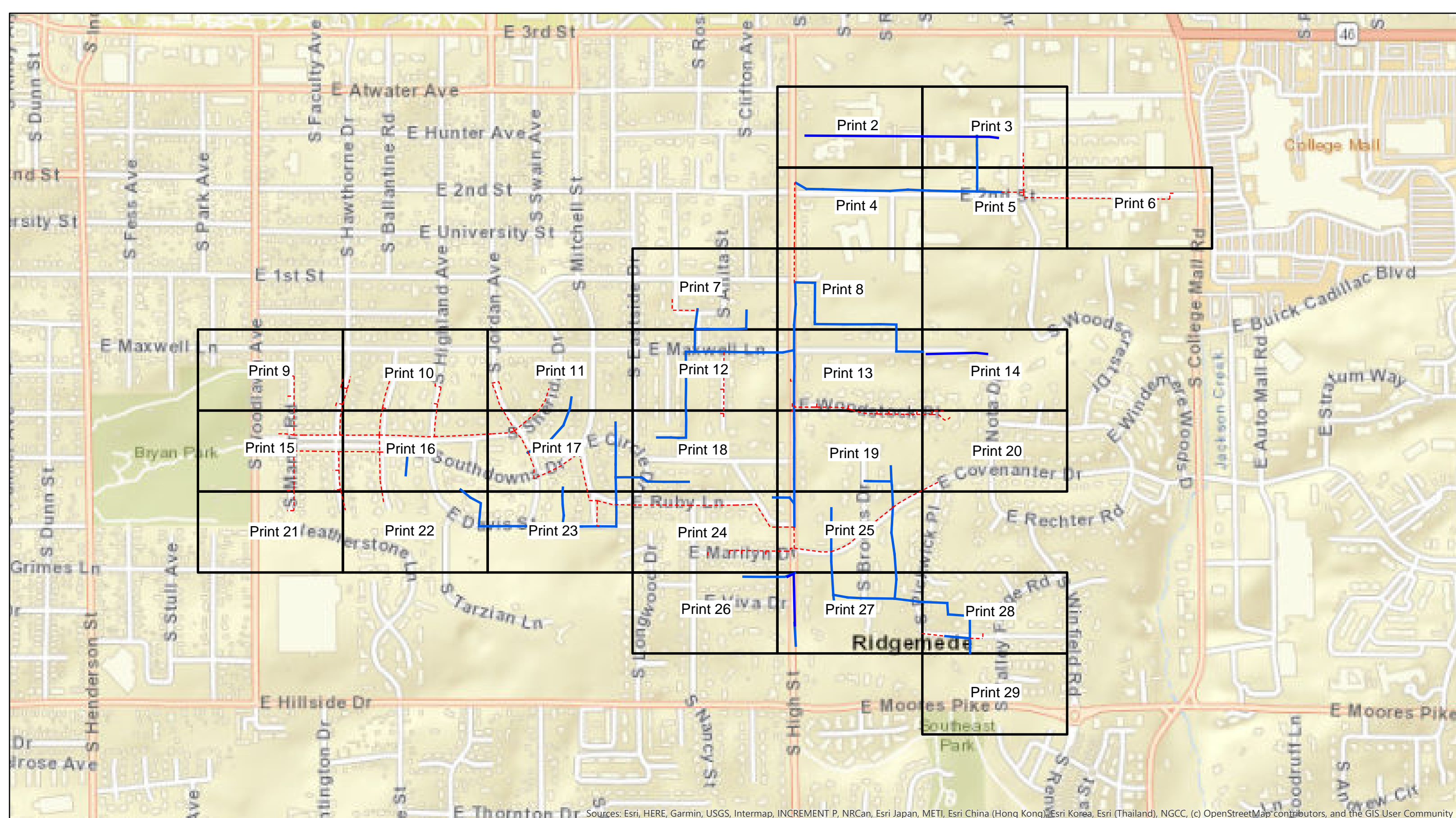

Sources: Esri, HERE, Garmin, USGS, Intermap, INCREMENT P, NRCan, Esri Japan, METI, Esri China (Hong Kong), Esri Korea, Esri (Thailand), NGCC, (c) OpenStreetMap contributors, and the GIS User Community



Legend BLC01a-F13 - E Maxwell Ln

- - - Conduit
- Overhead Strand
- Grids

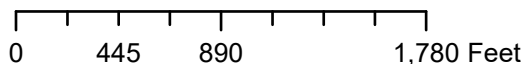

City of Bloomington, IN Permit:
Design View

REV	BY	DATE	DESCRIPTION
0	ICN	09/27/2022	PERMIT DRAWING



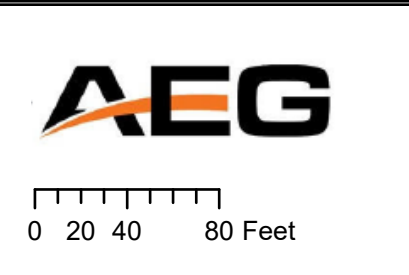
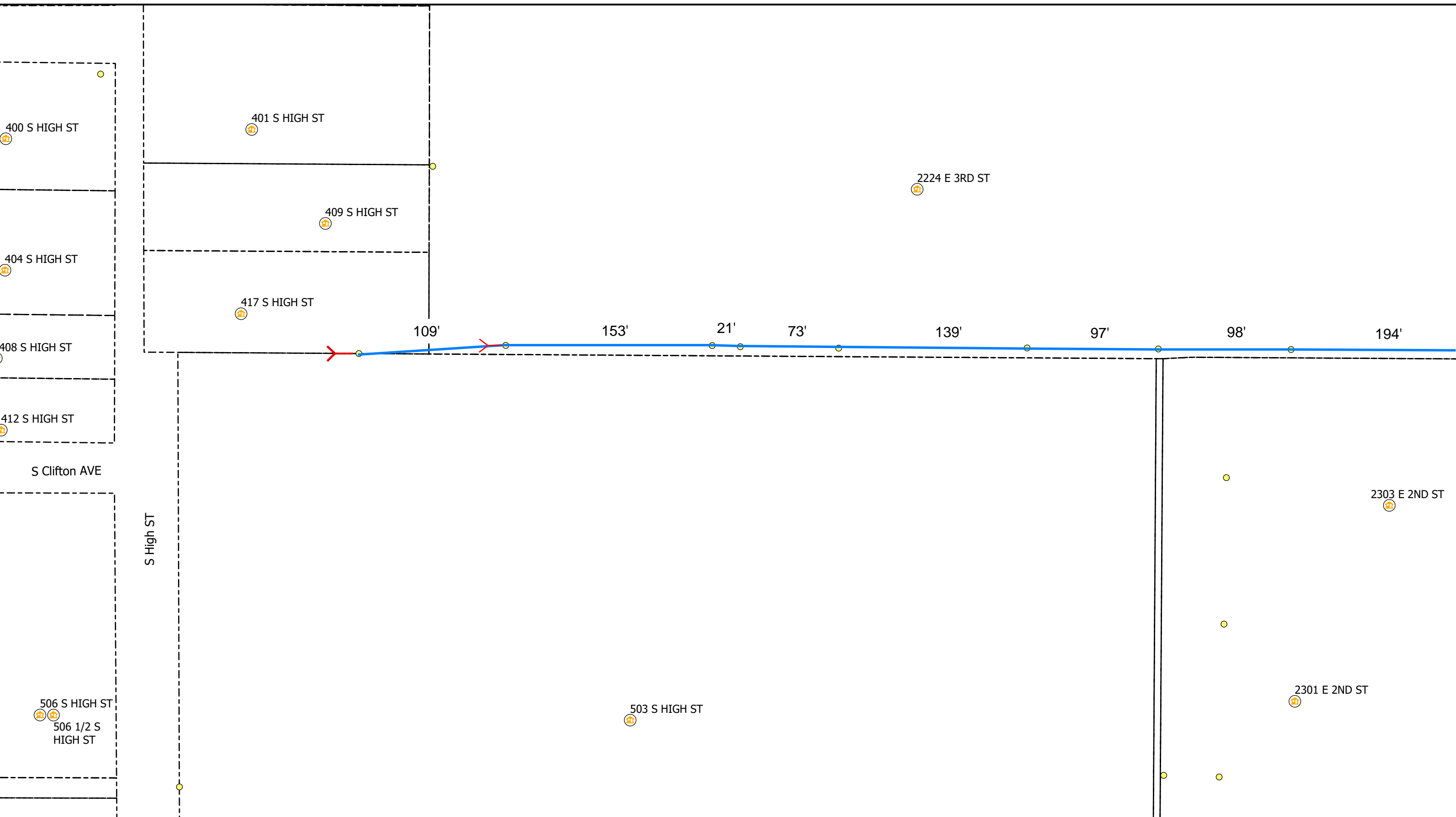

Legend

- Poles
- Conduit
- Anchor
- Overhead Strand
- Bloomington_Parcels
- Sidewalk
- Vaults
- Risers
- Grids
- Address

All Flowerpots 12" DIA

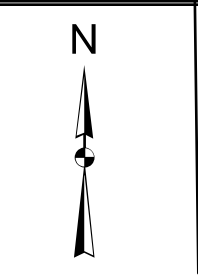

City of Bloomington, IN Permit:
Design View

REV	BY	DATE	DESCRIPTION
0	CN	09/27/2022	PERMIT DRAWING



Print 2 of 29

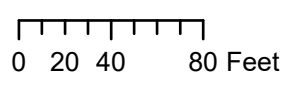
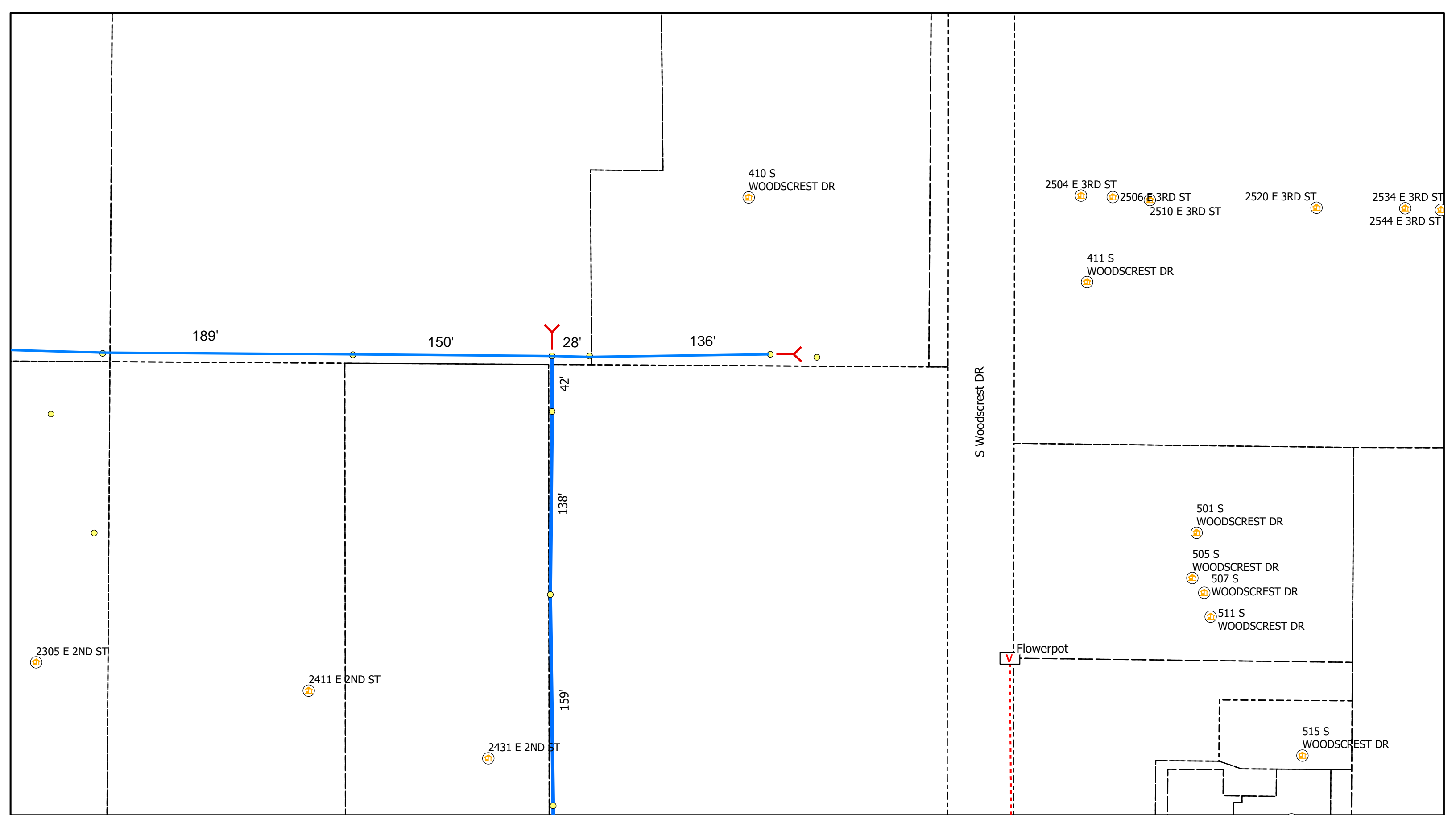

Legend

- Poles
- Overhead Strand
- V Vaults
- - - Conduit
- Bloomington_Parcels
- R Risers
- A Address
- Y Anchor
- K Sidewalk
- Grids

All Flowerpots 12" DIA



City of Bloomington, IN Permit:
Design View

REV	BY	DATE	DESCRIPTION
0	CN	09/27/2022	PERMIT DRAWING



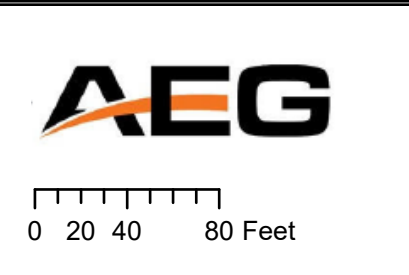
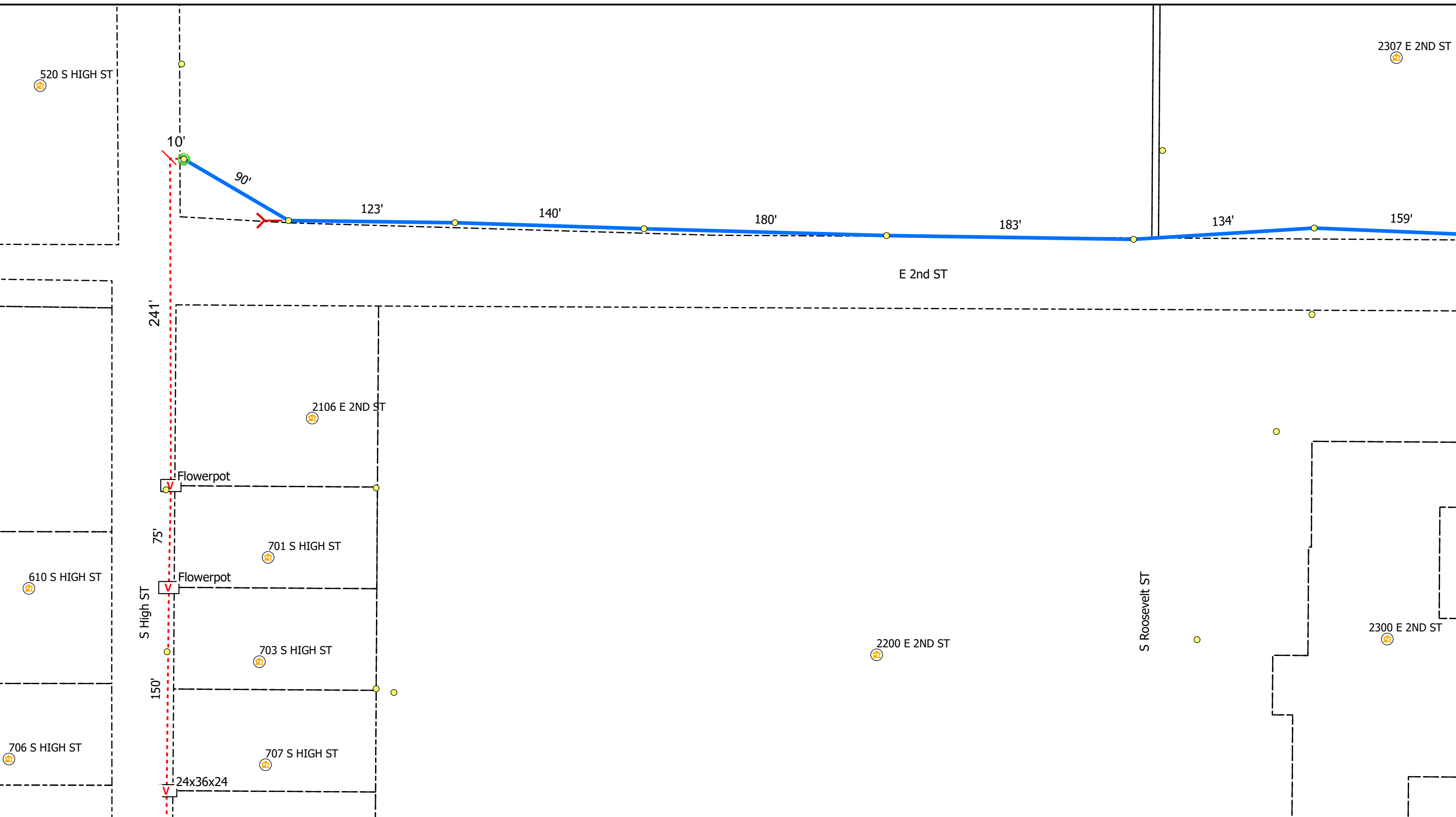

Legend

- Poles
- Overhead Strand
- Ⓜ Vaults
- ⋯ Conduit
- Ⓡ Risers
- Ⓜ Address
- Y Anchor
- ← Sidewalk
- ▭ Grids
- Ⓜ Bloomington_Parcels

All Flowerpots 12" DIA

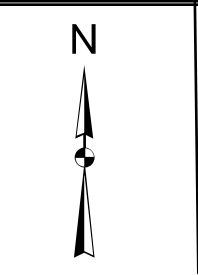

City of Bloomington, IN Permit:
Design View

REV	BY	DATE	DESCRIPTION
0	CN	09/27/2022	PERMIT DRAWING

Print 4 of 29

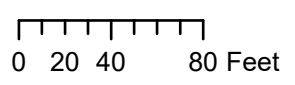
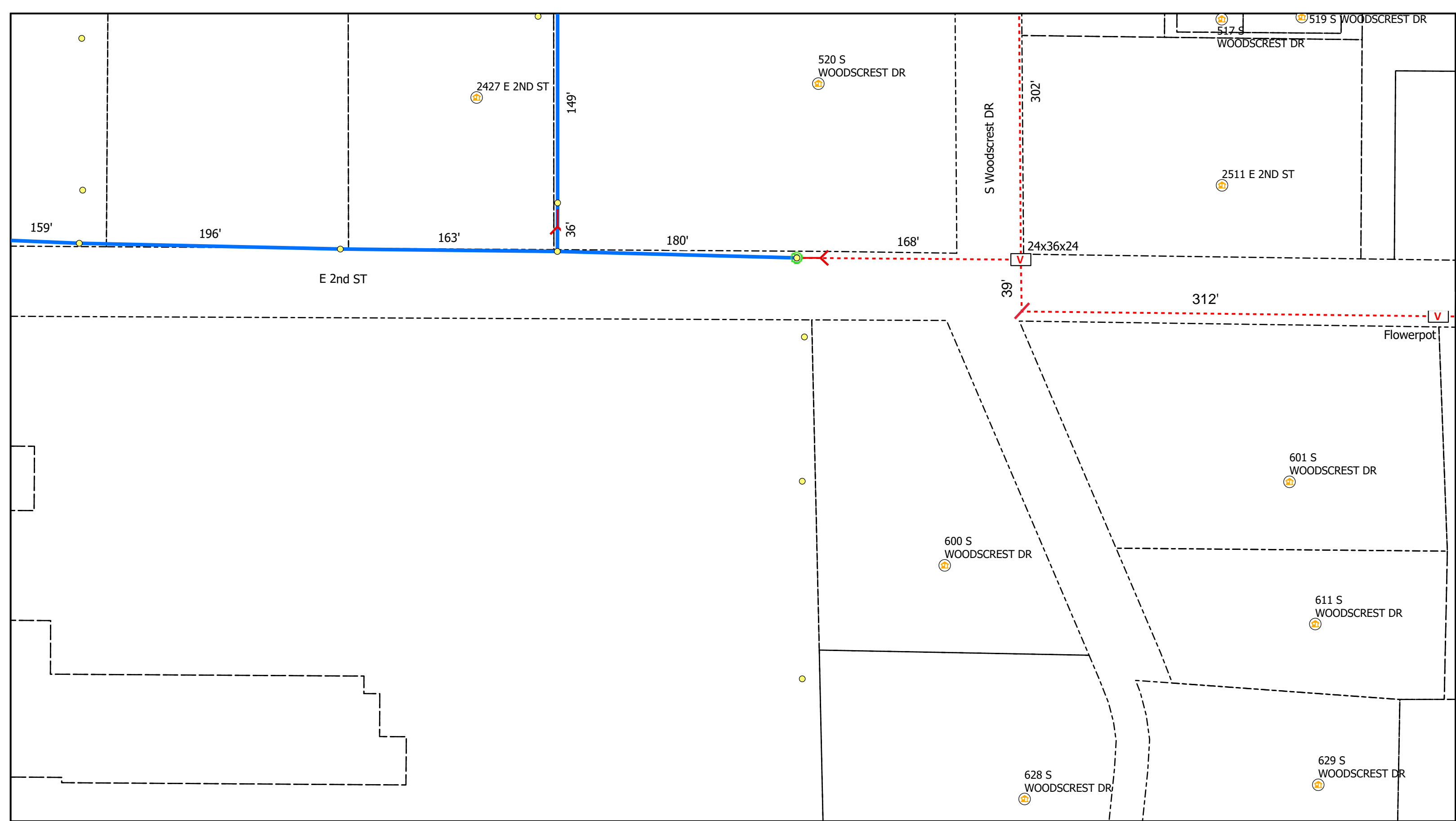

Legend

- Poles
- Overhead Strand
- V Vaults
- - - Conduit
- Bloomington_Parcels
- R Risers
- A Address
- Y Anchor
- ← Sidewalk
- Grids

All Flowerpots 12" DIA



City of Bloomington, IN Permit:
Design View

REV	BY	DATE	DESCRIPTION
0	CN	09/27/2022	PERMIT DRAWING



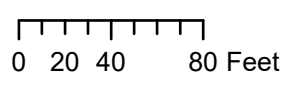
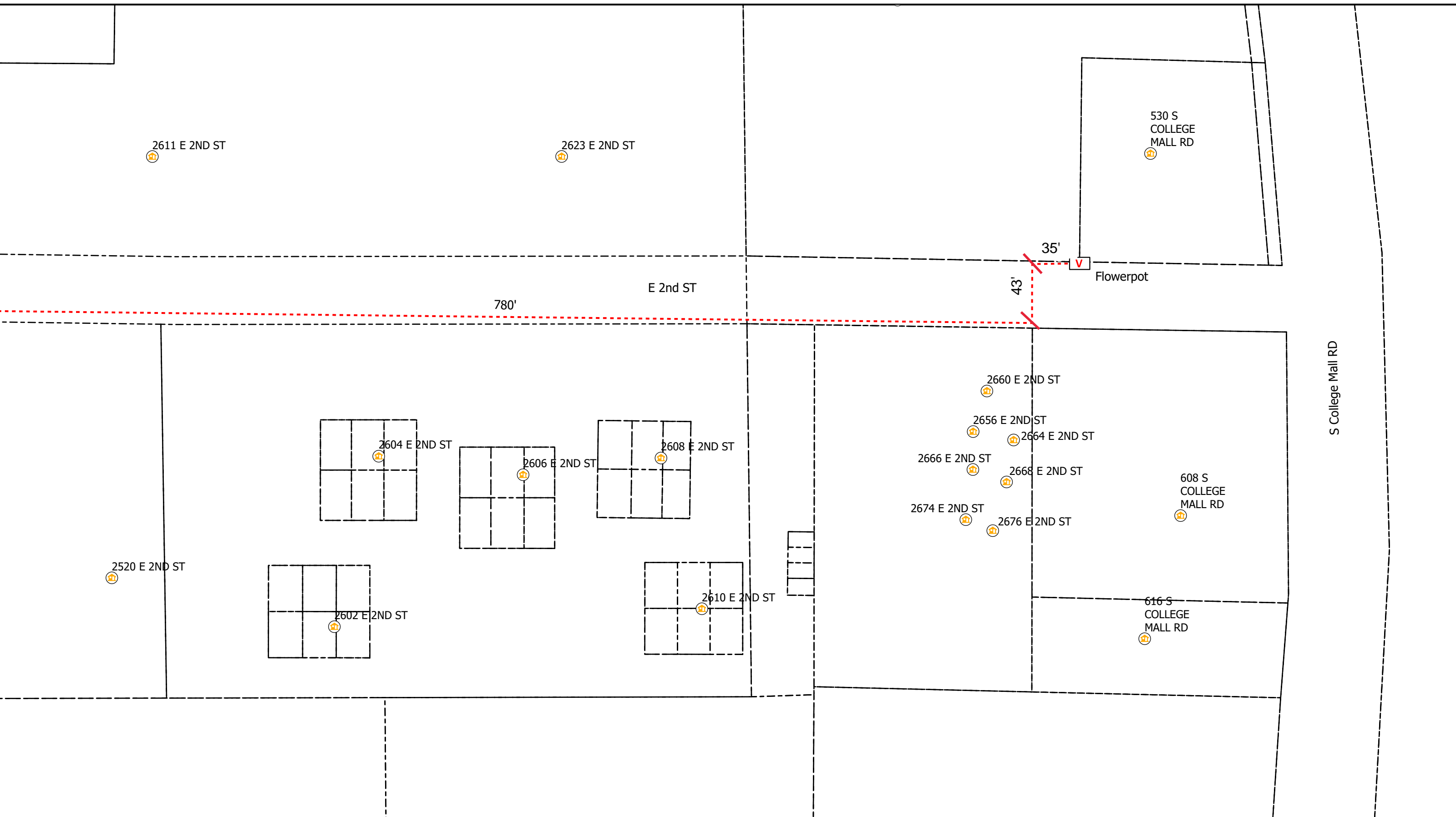

Legend

- Poles
- Overhead Strand
- V Vaults
- - - Conduit
- Bloomington_Parcels
- R Risers
- A Address
- Y Anchor
- ← Sidewalk
- Grids

All Flowerpots 12" DIA



City of Bloomington, IN Permit:
Design View

REV	BY	DATE	DESCRIPTION
0	CN	09/27/2022	PERMIT DRAWING



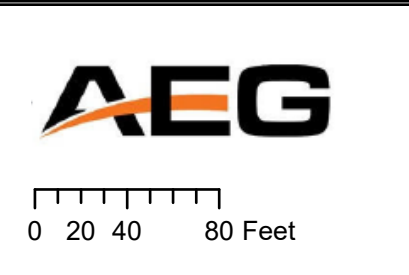
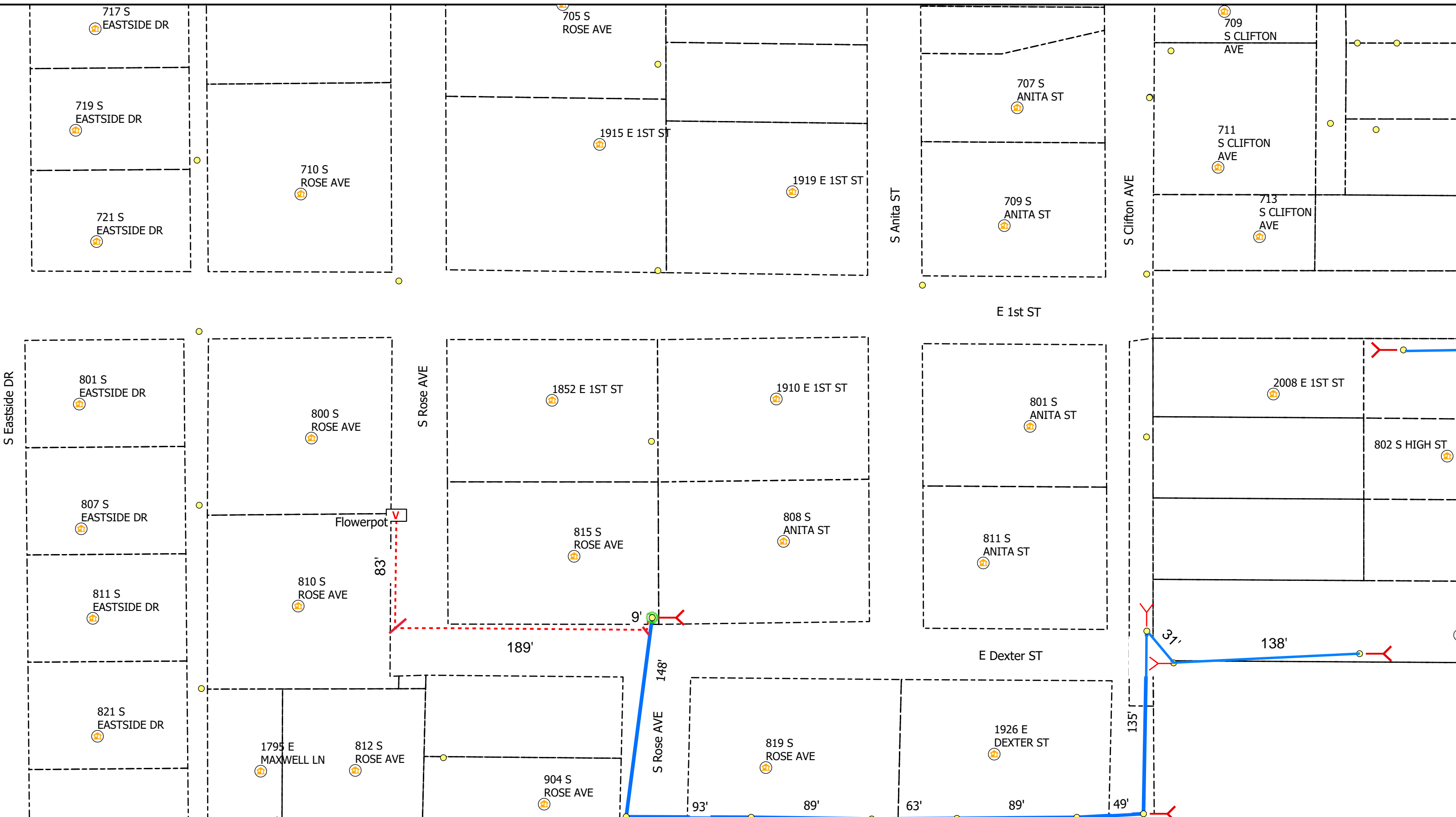

Legend

- Poles
- Overhead Strand
- V Vaults
- Conduit
- Bloomington_Parcels
- R Risers
- A Address
- Y Anchor
- ← Sidewalk
- Grids

All Flowerpots 12" DIA

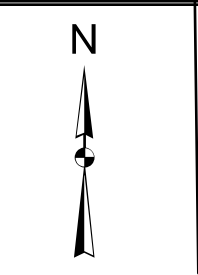

City of Bloomington, IN Permit:
Design View

REV	BY	DATE	DESCRIPTION
0	CN	09/27/2022	PERMIT DRAWING

Print 7 of 29

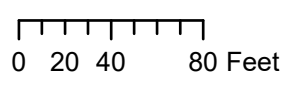
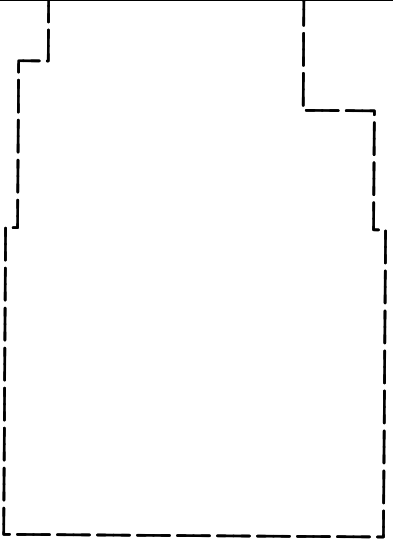
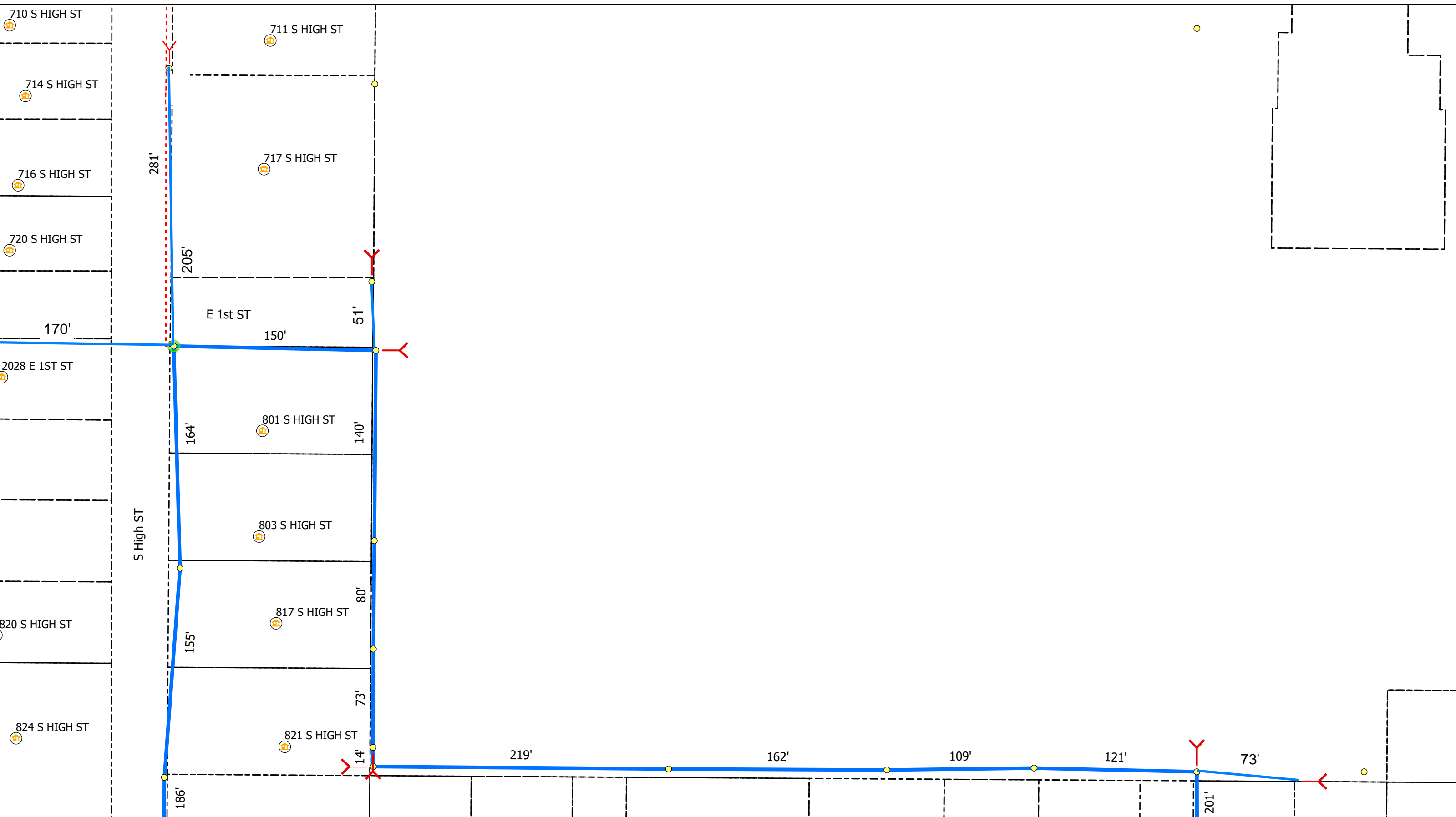

Legend

- Poles
- Overhead Strand
- Vaults
- Conduit
- Bloomington_Parcels
- Risers
- Address
- Y Anchor
- ← Sidewalk
- Grids

All Flowerpots 12" DIA



City of Bloomington, IN Permit:
Design View

REV	BY	DATE	DESCRIPTION
0	CN	09/27/2022	PERMIT DRAWING



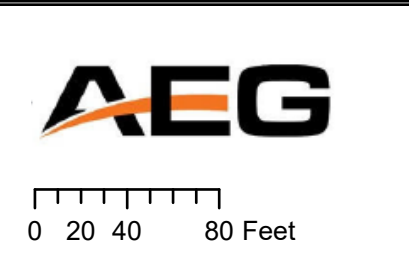
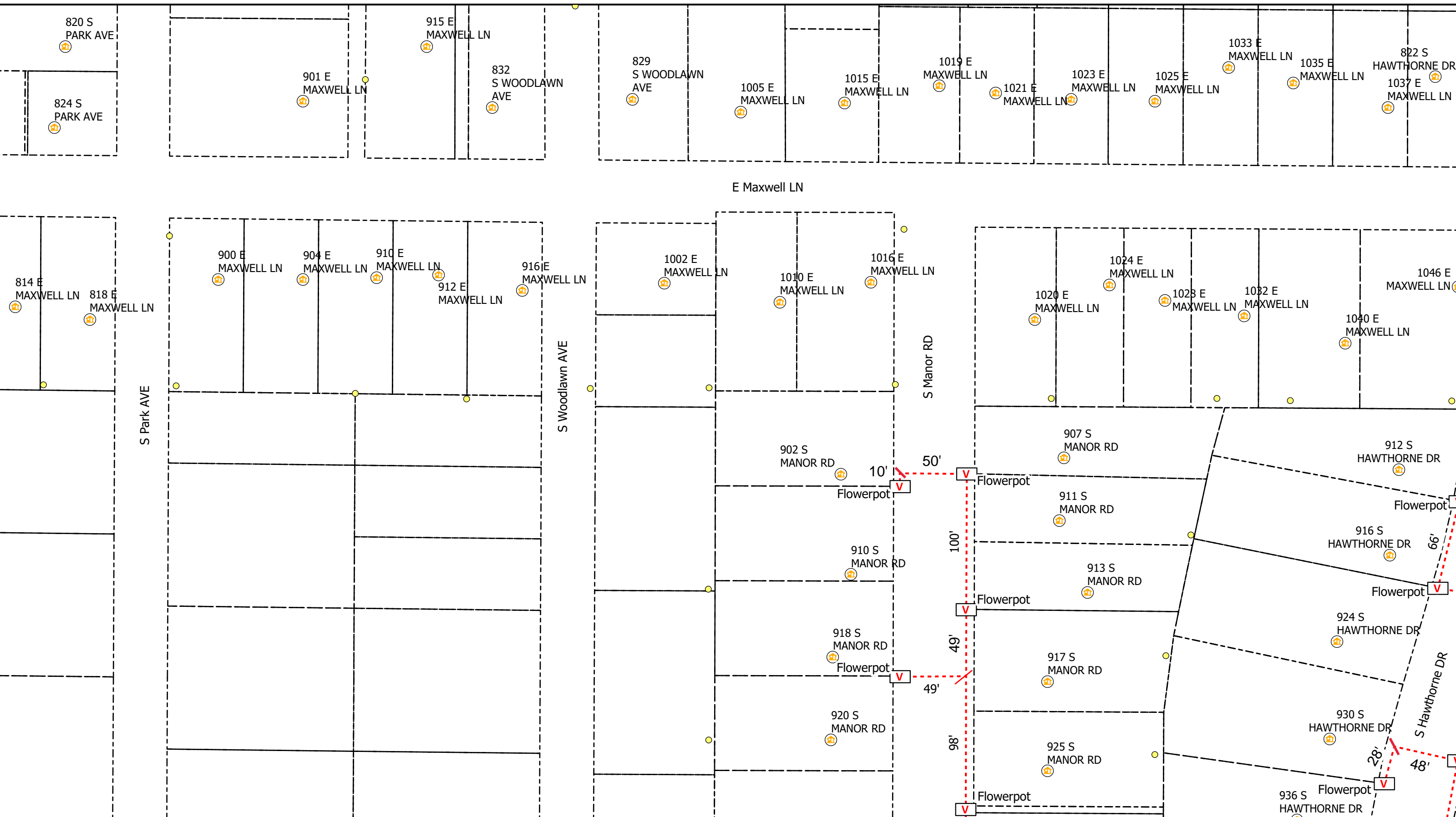

Legend

- Poles
- Overhead Strand
- V Vaults
- Conduit
- Bloomington_Parcels
- R Risers
- A Address
- Y Anchor
- ← Sidewalk
- Grids

All Flowerpots 12" DIA

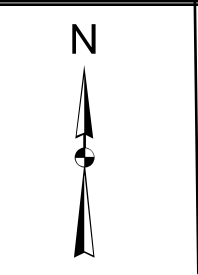

City of Bloomington, IN Permit:
Design View

REV	BY	DATE	DESCRIPTION
0	CN	09/27/2022	PERMIT DRAWING

Print 9 of 29

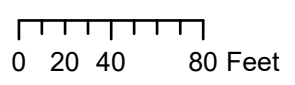
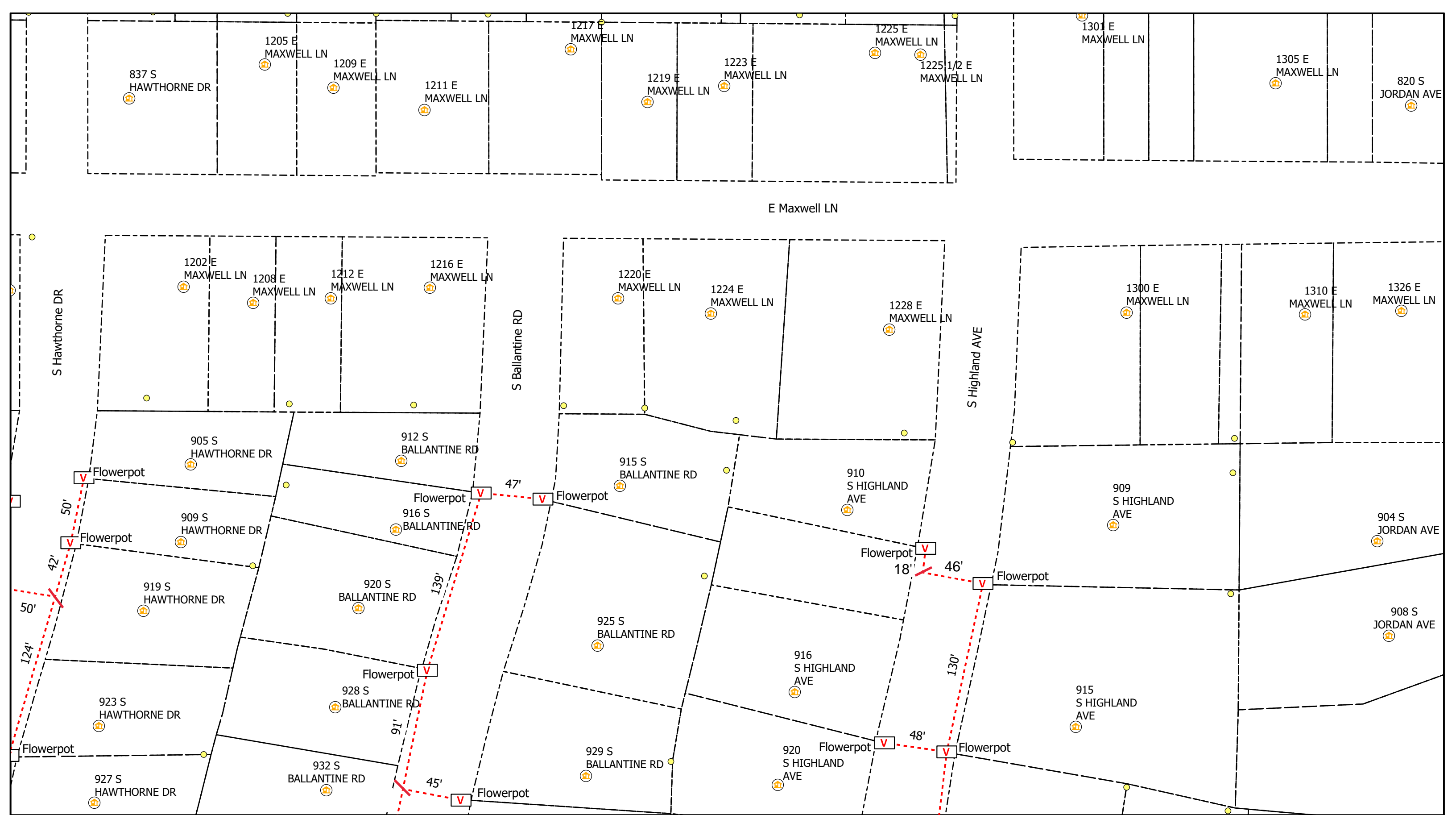

Legend

- Poles
- Overhead Strand
- Vaults
- Bloomington_Parcels
- Risers
- Address
- Conduit
- Anchor
- Sidewalk
- Grids

All Flowerpots 12" DIA



City of Bloomington, IN Permit:
Design View

REV	BY	DATE	DESCRIPTION
0	CN	09/27/2022	PERMIT DRAWING



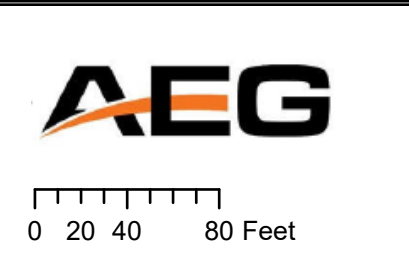

Legend

- Poles
- Overhead Strand
- V Vaults
- Conduit
- Bloomington_Parcels
- R Risers
- A Address
- Y Anchor
- ← Sidewalk
- Grids

All Flowerpots 12" DIA

All Flowerpots 12" DIA

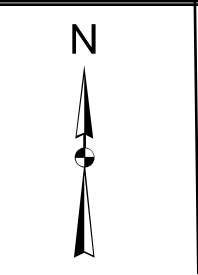

City of Bloomington, IN Permit:
Design View

REV	BY	DATE	DESCRIPTION
0	CN	09/27/2022	PERMIT DRAWING

Print 11 of 29

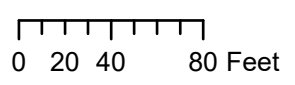
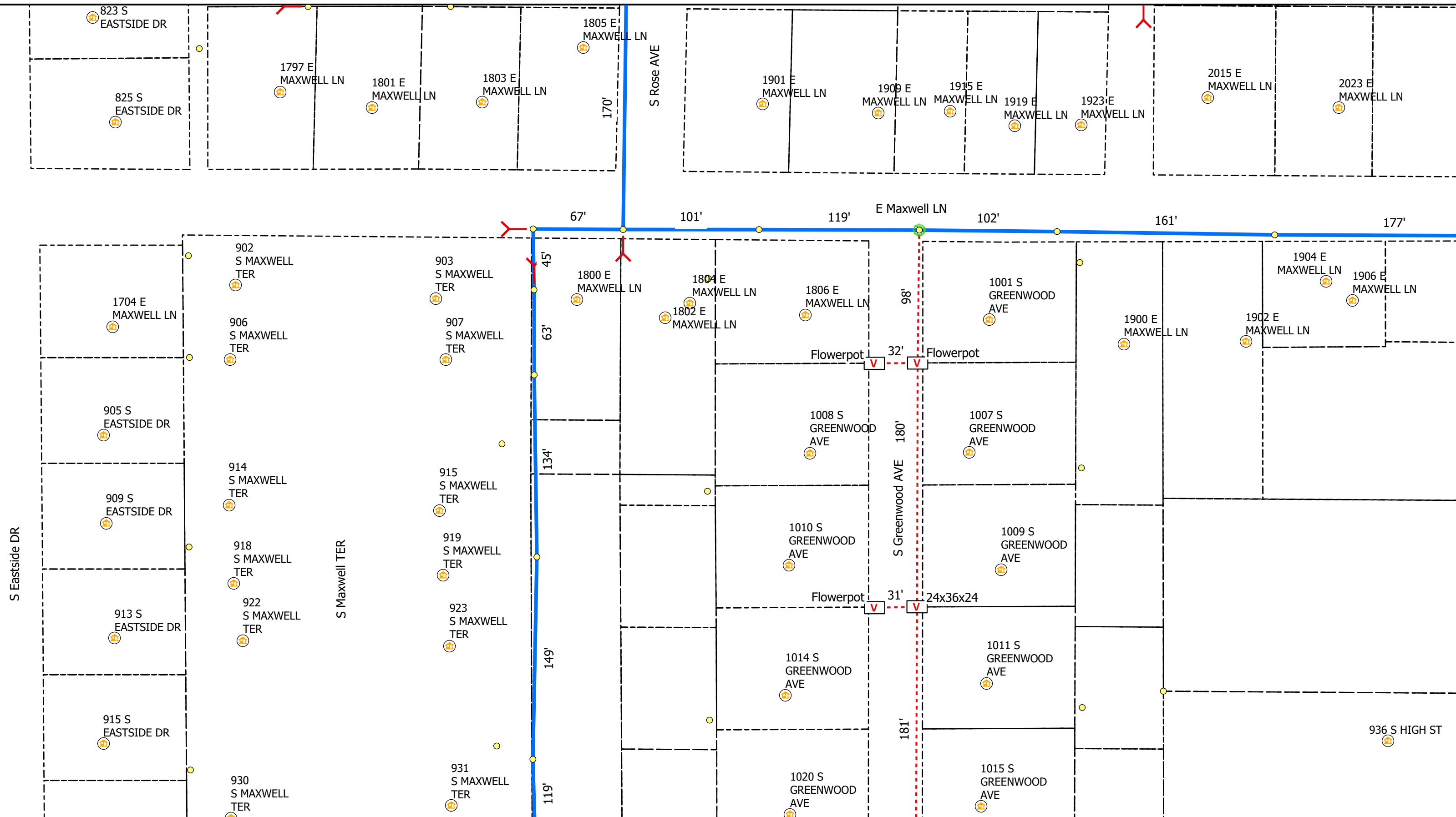

Legend

- Poles
- Overhead Strand
- V Vaults
- - - Conduit
- Bloomington_Parcels
- R Risers
- A Address
- Y Anchor
- ← Sidewalk
- Grids

All Flowerpots 12" DIA



City of Bloomington, IN Permit:
Design View

REV	BY	DATE	DESCRIPTION
0	CN	09/27/2022	PERMIT DRAWING



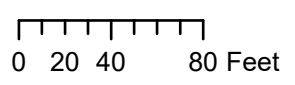
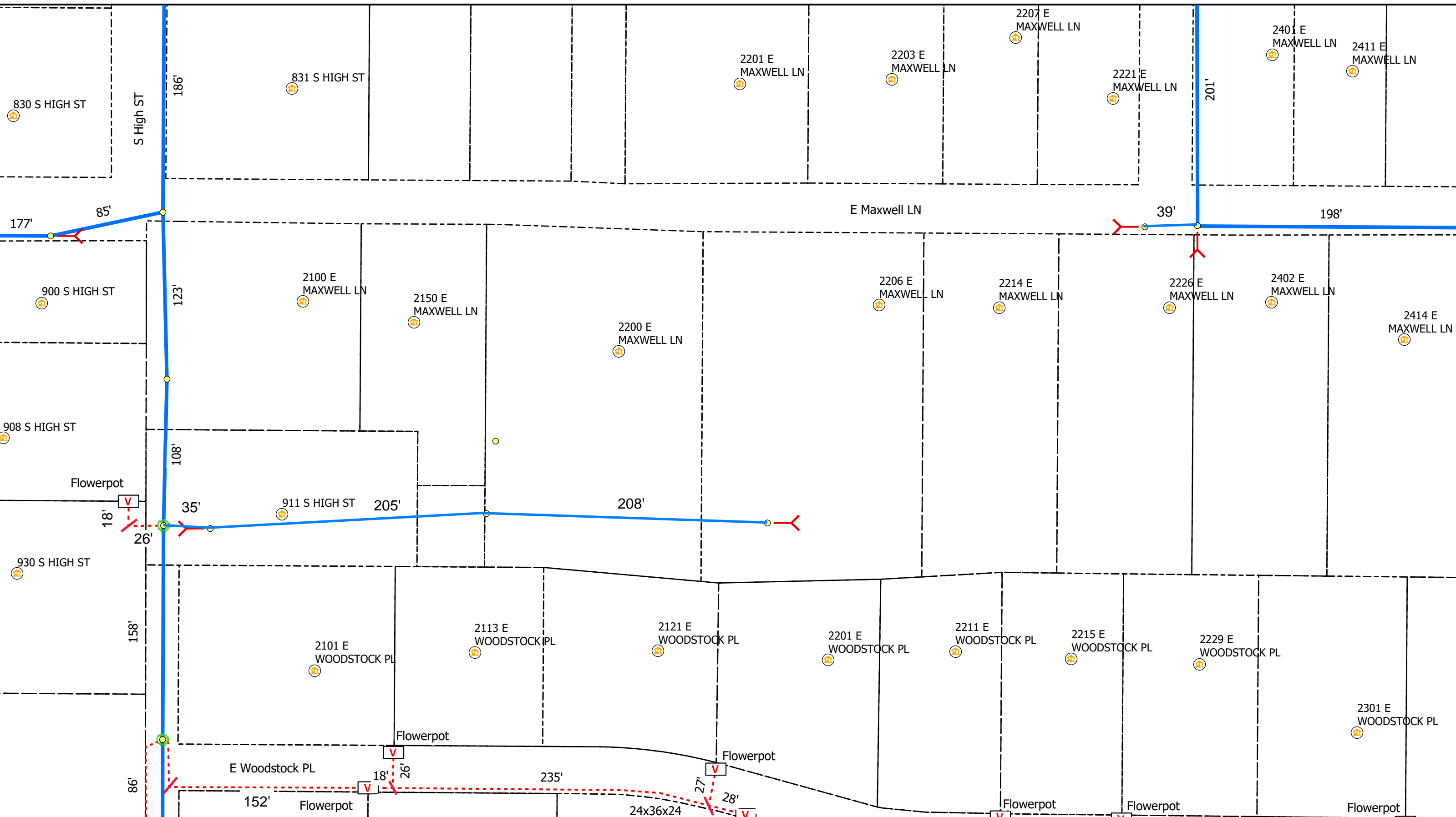

Legend

- Poles
- Overhead Strand
- V Vaults
- - - Conduit
- Bloomington_Parcels
- R Risers
- ⊙ Address
- Y Anchor
- ← Sidewalk
- Grids

All Flowerpots 12" DIA



City of Bloomington, IN Permit:
Design View

REV	BY	DATE	DESCRIPTION
0	CN	09/27/2022	PERMIT DRAWING



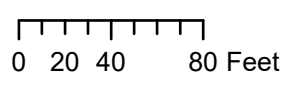
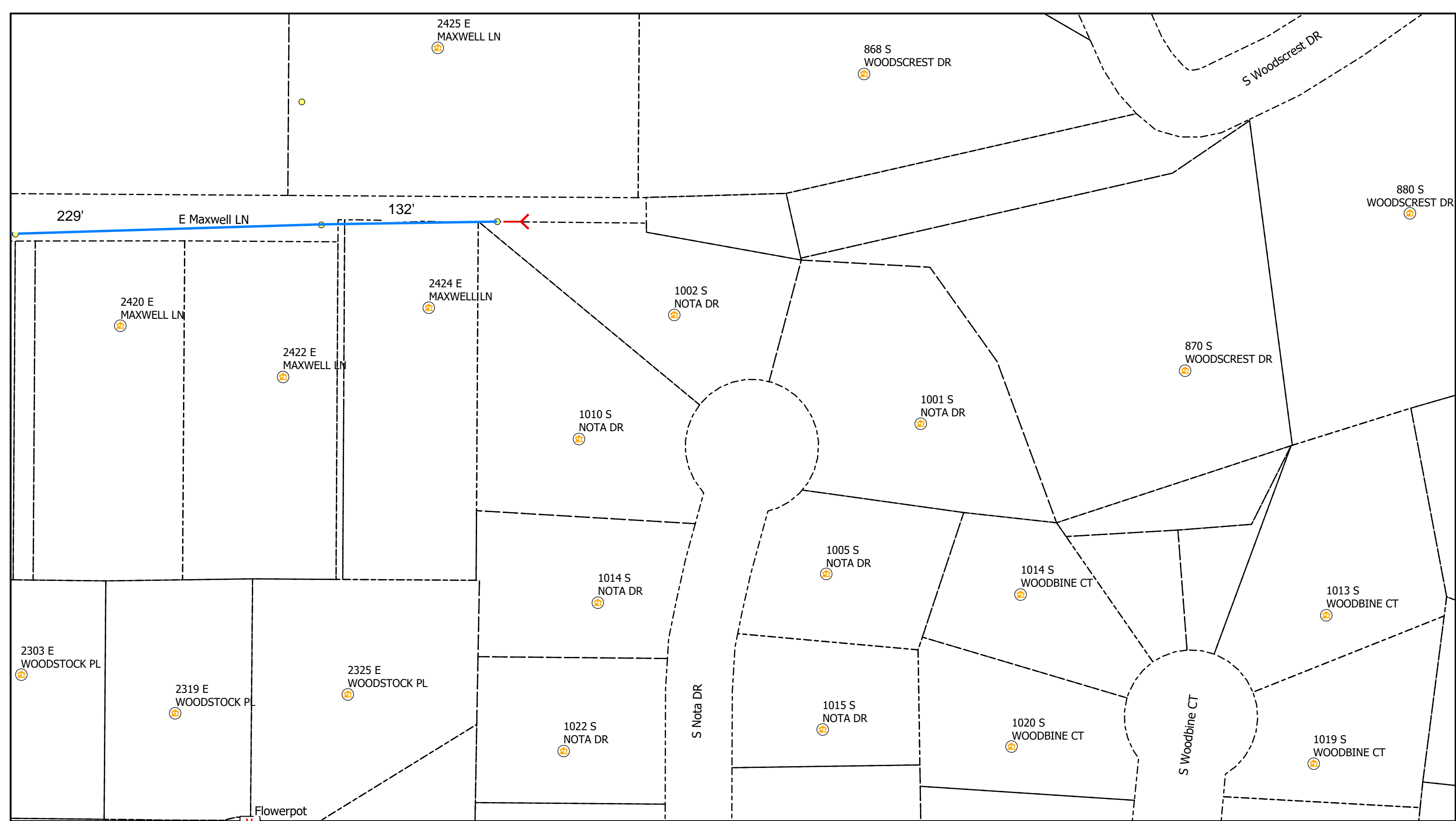

Legend

- Poles
- Overhead Strand
- V Vaults
- - - Conduit
- Bloomington_Parcels
- R Risers
- Grids
- Y Anchor
- ← Sidewalk
- 🏠 Address

All Flowerpots 12" DIA



City of Bloomington, IN Permit:
Design View

REV	BY	DATE	DESCRIPTION
0	CN	09/27/2022	PERMIT DRAWING



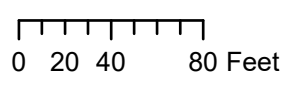
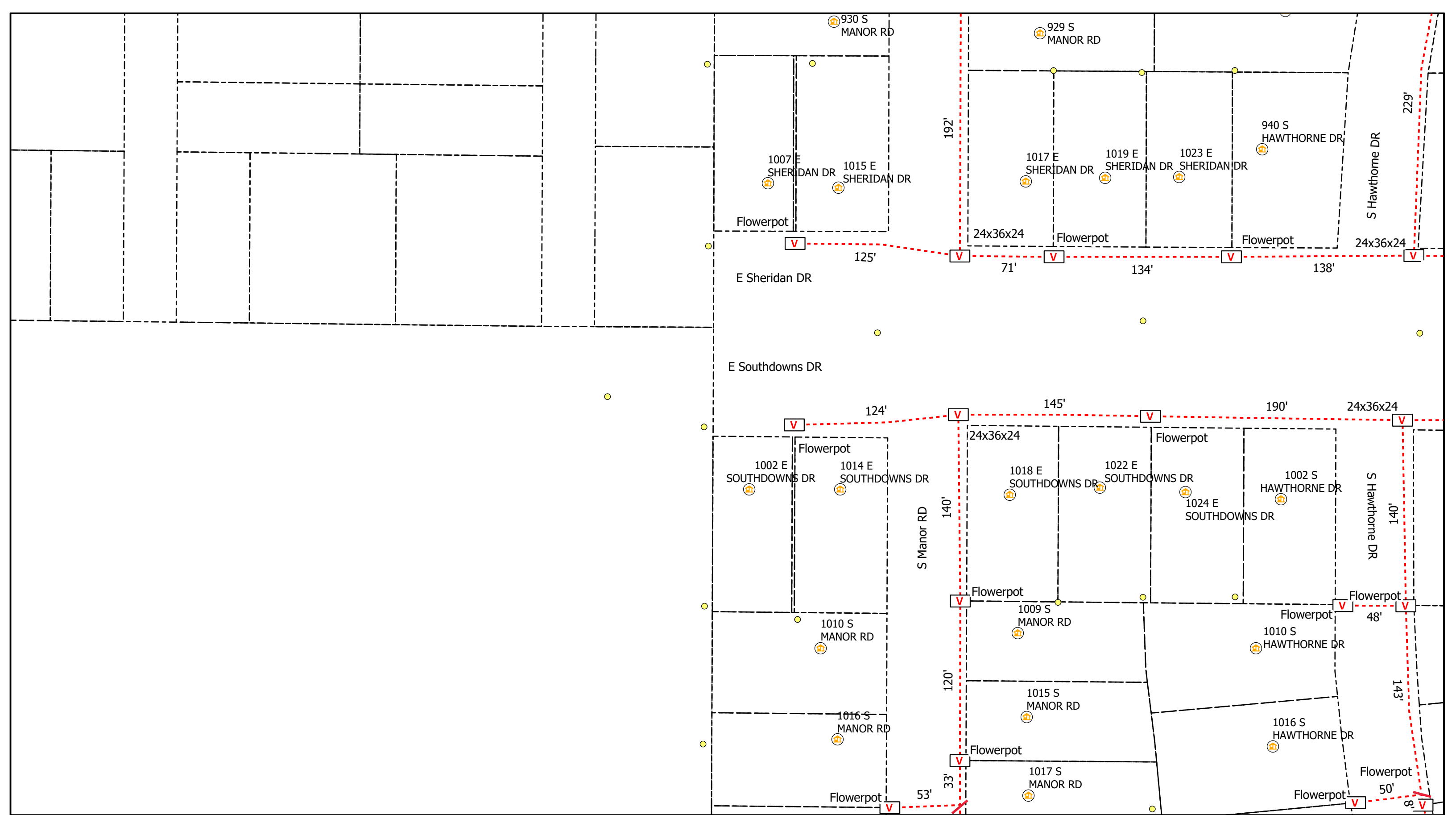

Legend

- Poles
- Overhead Strand
- V Vaults
- - - Conduit
- Bloomington_Parcels
- R Risers
- Address
- Y Anchor
- ← Sidewalk
- Grids

All Flowerpots 12" DIA



City of Bloomington, IN Permit:
Design View

REV	BY	DATE	DESCRIPTION
0	CN	09/27/2022	PERMIT DRAWING



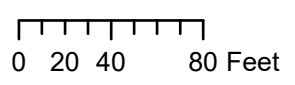
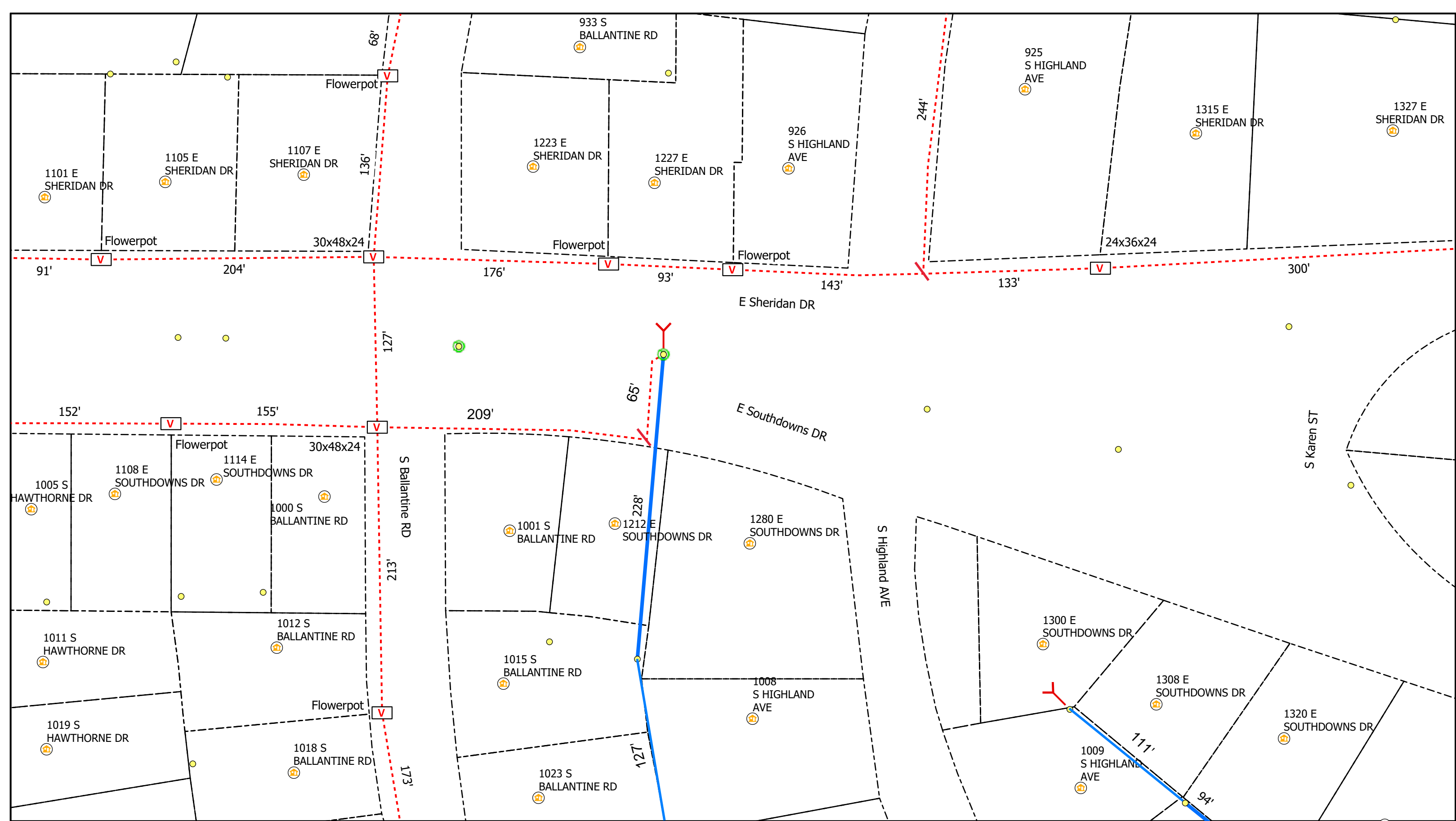

Legend

- Poles
- Vaults
- Conduit
- Bloomington_Parcels
- Risers
- Grids
- Overhead Strand
- Sidewalk
- Anchor
- Address

All Flowerpots 12" DIA



City of Bloomington, IN Permit:
Design View

REV	BY	DATE	DESCRIPTION
0	CN	09/27/2022	PERMIT DRAWING



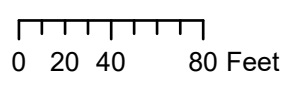
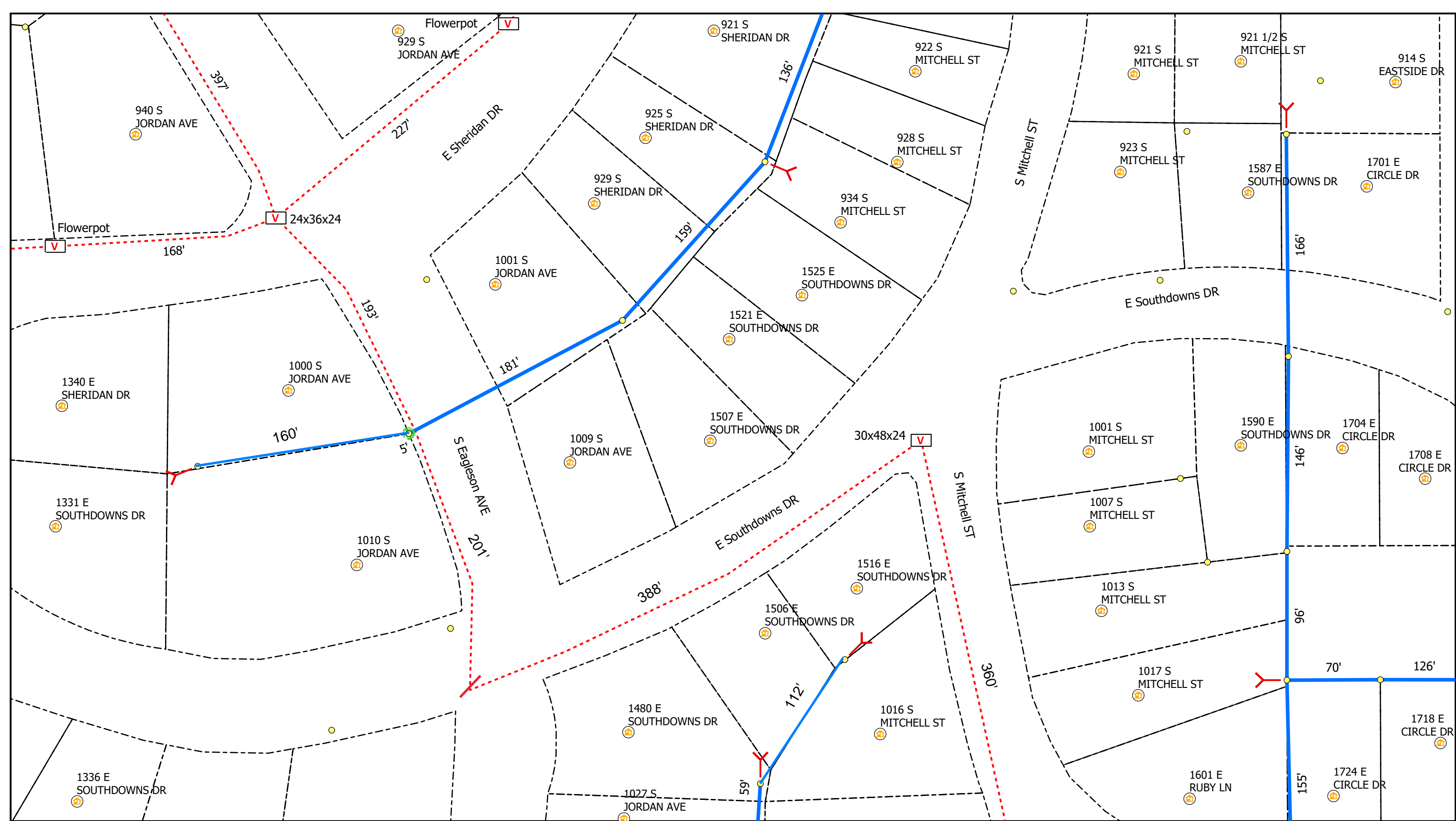

Legend

- Poles
- Overhead Strand
- V Vaults
- Conduit
- Bloomington_Parcels
- R Risers
- A Address
- Y Anchor
- ← Sidewalk
- Grids

All Flowerpots 12" DIA



City of Bloomington, IN Permit:
Design View

REV	BY	DATE	DESCRIPTION
0	CN	09/27/2022	PERMIT DRAWING



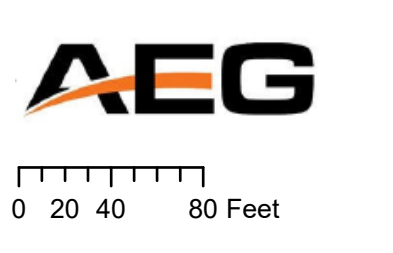
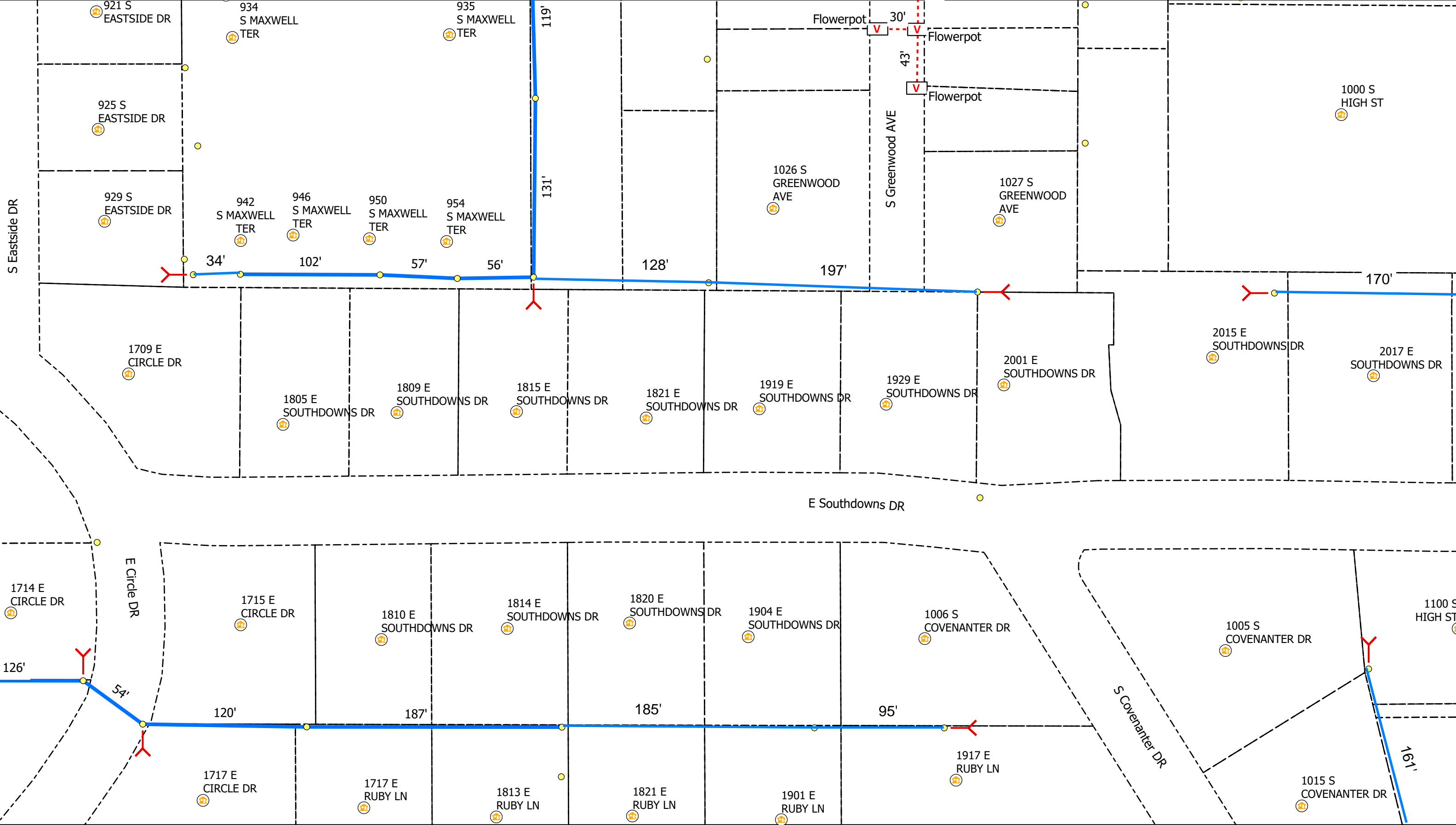

Legend

- Poles
- Overhead Strand
- ⌞ Bloomington_Parcels
- ⌞ Vaults
- ⋯ Conduit
- ⊕ Risers
- ⊕ Address
- ⌞ Anchor
- ⌞ Sidewalk
- ⌞ Grids

All Flowerpots 12" DIA

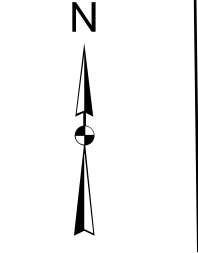

City of Bloomington, IN Permit:
Design View

REV	BY	DATE	DESCRIPTION
0	CN	09/27/2022	PERMIT DRAWING

Print 18 of 29

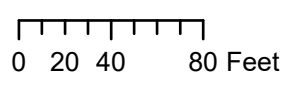
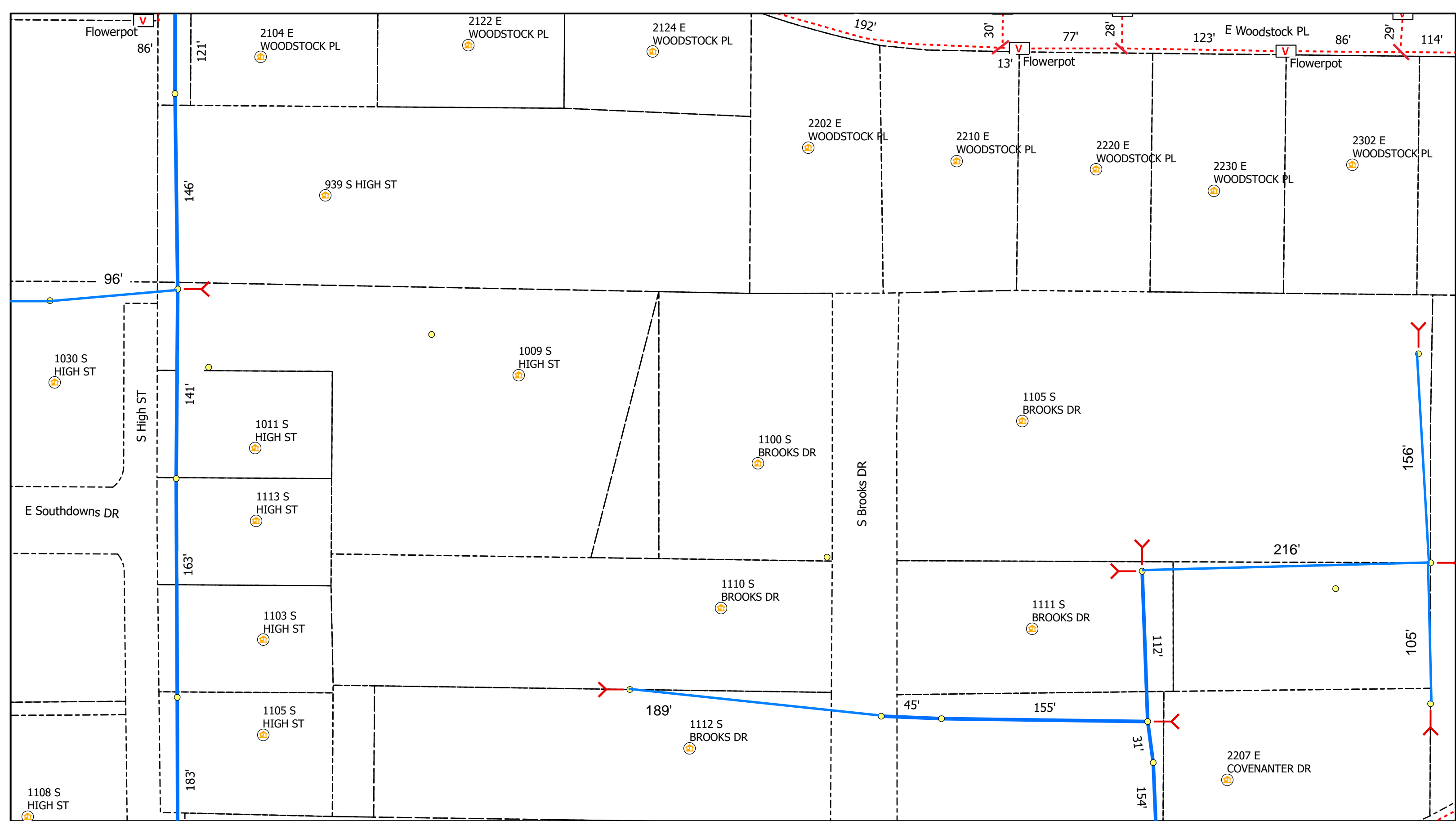

Legend

- Poles
- Overhead Strand
- V Vaults
- Conduit
- Bloomington_Parcels
- R Risers
- A Address
- Y Anchor
- ← Sidewalk
- Grids

All Flowerpots 12" DIA



City of Bloomington, IN Permit:
Design View

REV	BY	DATE	DESCRIPTION
0	CN	09/27/2022	PERMIT DRAWING



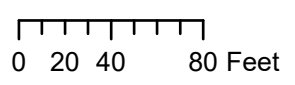

Legend

- Poles
- Overhead Strand
- V Vaults
- - - Conduit
- Bloomington_Parcels
- R Risers
- + Address
- Y Anchor
- ← Sidewalk
- Grids

All Flowerpots 12" DIA



City of Bloomington, IN Permit:
Design View

REV	BY	DATE	DESCRIPTION
0	CN	09/27/2022	PERMIT DRAWING



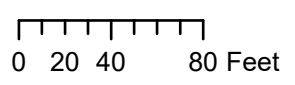
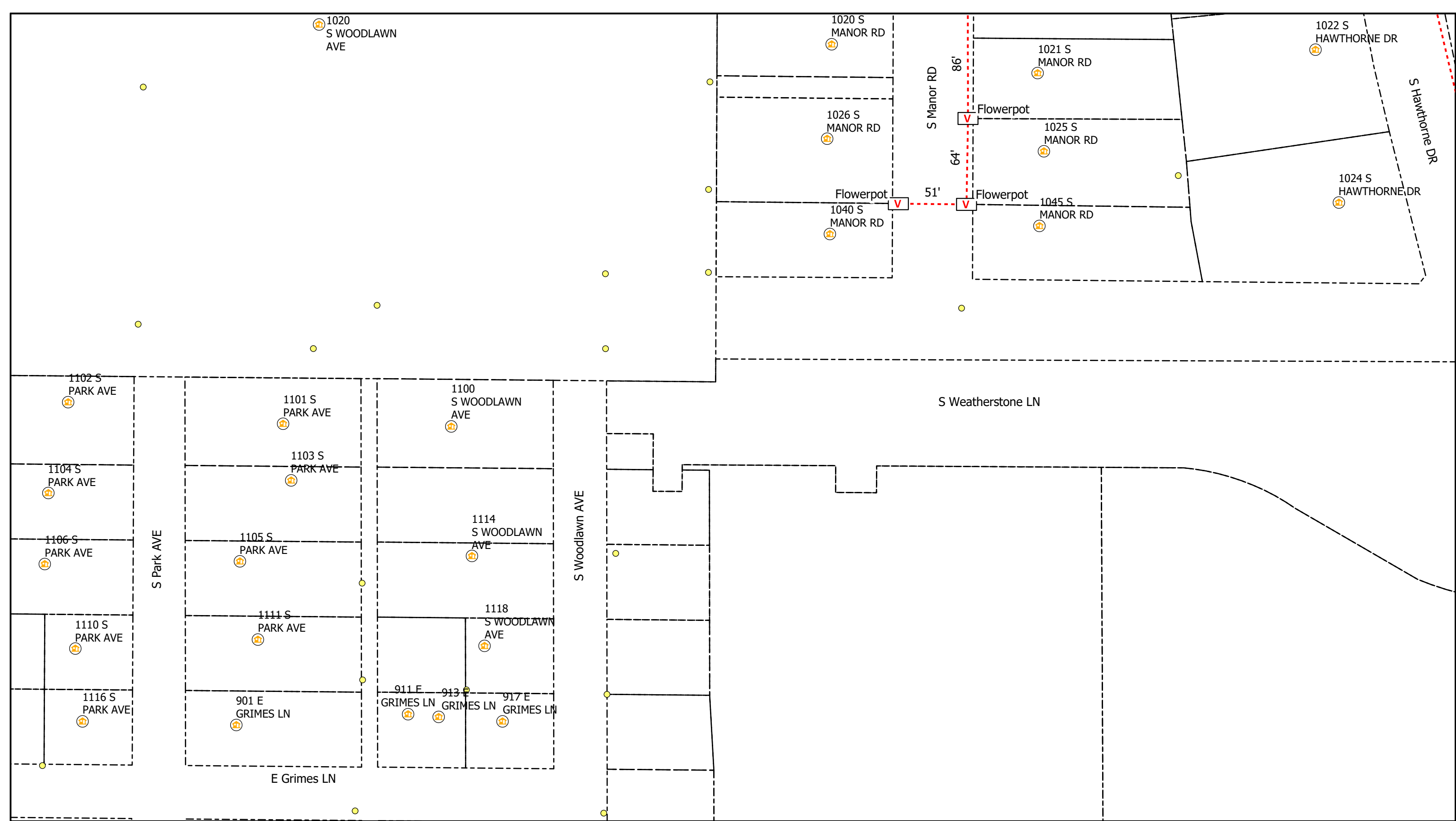

Legend

- Poles
- Overhead Strand
- V Vaults
- - - Conduit
- Bloomington_Parcels
- R Risers
- A Address
- Y Anchor
- ← Sidewalk
- Grids

All Flowerpots 12" DIA



City of Bloomington, IN Permit:
Design View

REV	BY	DATE	DESCRIPTION
0	CN	09/27/2022	PERMIT DRAWING



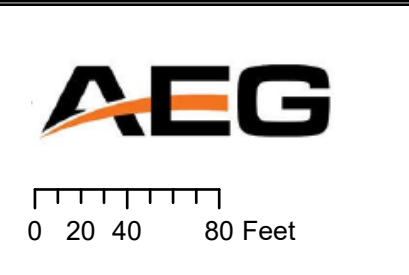
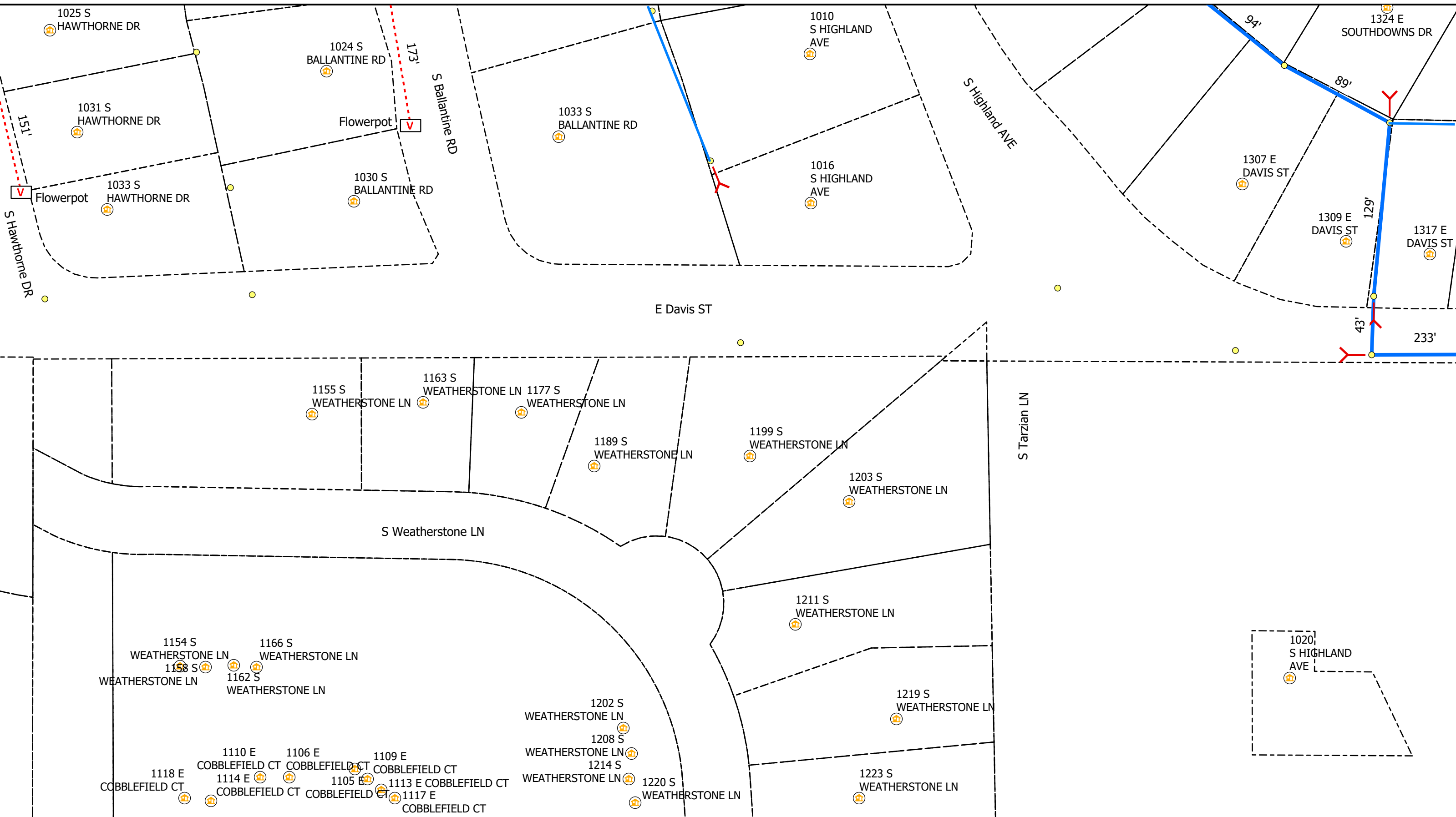

Legend

- Poles
- Overhead Strand
- V Vaults
- - - Conduit
- Bloomington_Parcels
- R Risers
- ⊕ Address
- Y Anchor
- ← Sidewalk
- Grids

All Flowerpots 12" DIA

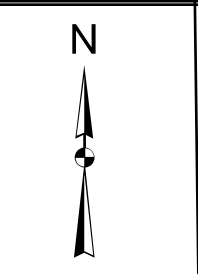

City of Bloomington, IN Permit:
Design View

REV	BY	DATE	DESCRIPTION
0	CN	09/27/2022	PERMIT DRAWING



Print 22 of 29

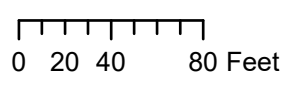
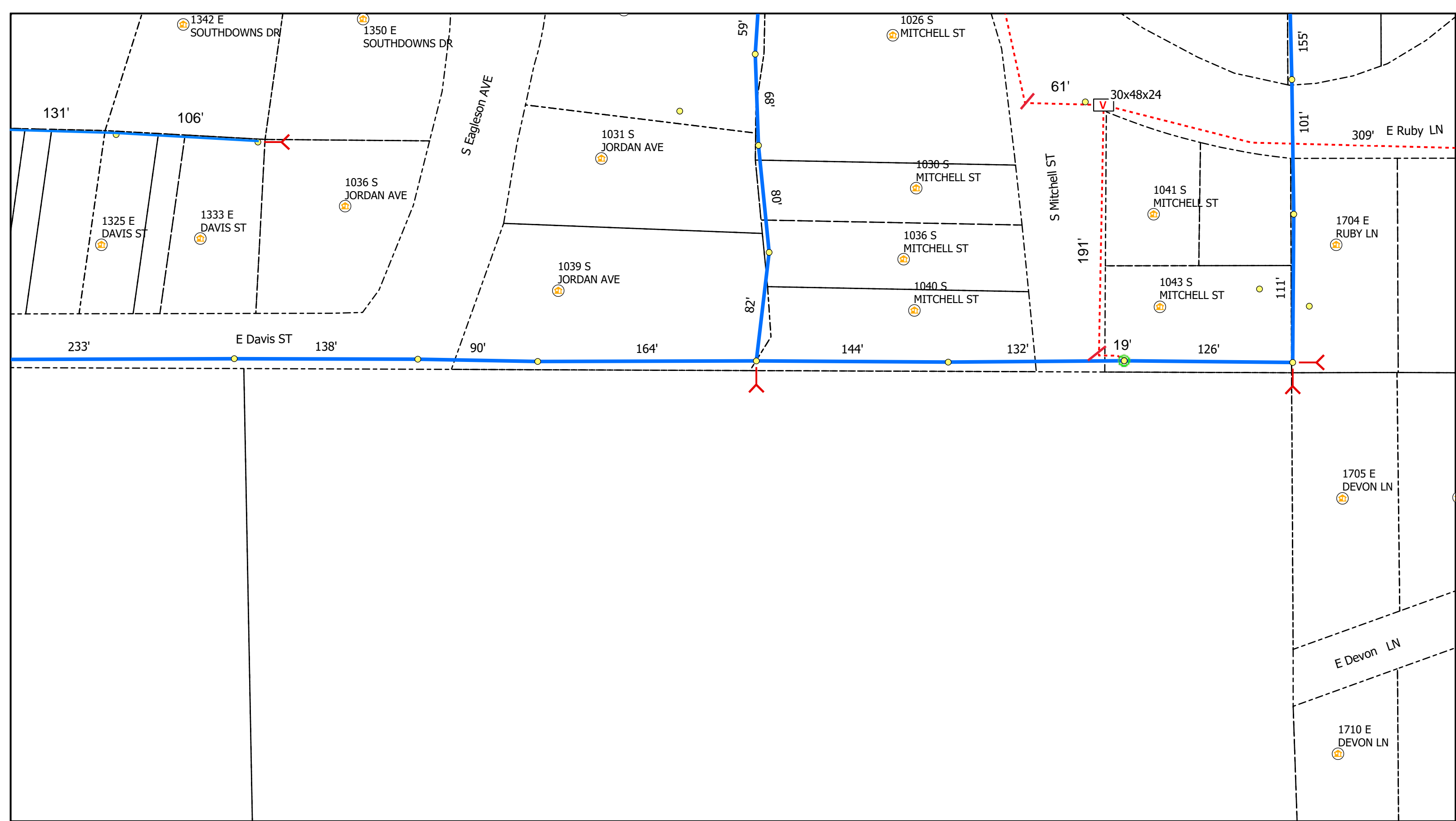

Legend

- Poles
- Overhead Strand
- V Vaults
- - - Conduit
- Bloomington_Parcels
- R Risers
- Ⓜ Address
- Y Anchor
- ← Sidewalk
- Grids

All Flowerpots 12" DIA



City of Bloomington, IN Permit:
Design View

REV	BY	DATE	DESCRIPTION
0	CN	09/27/2022	PERMIT DRAWING



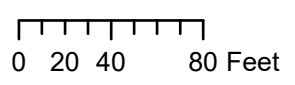
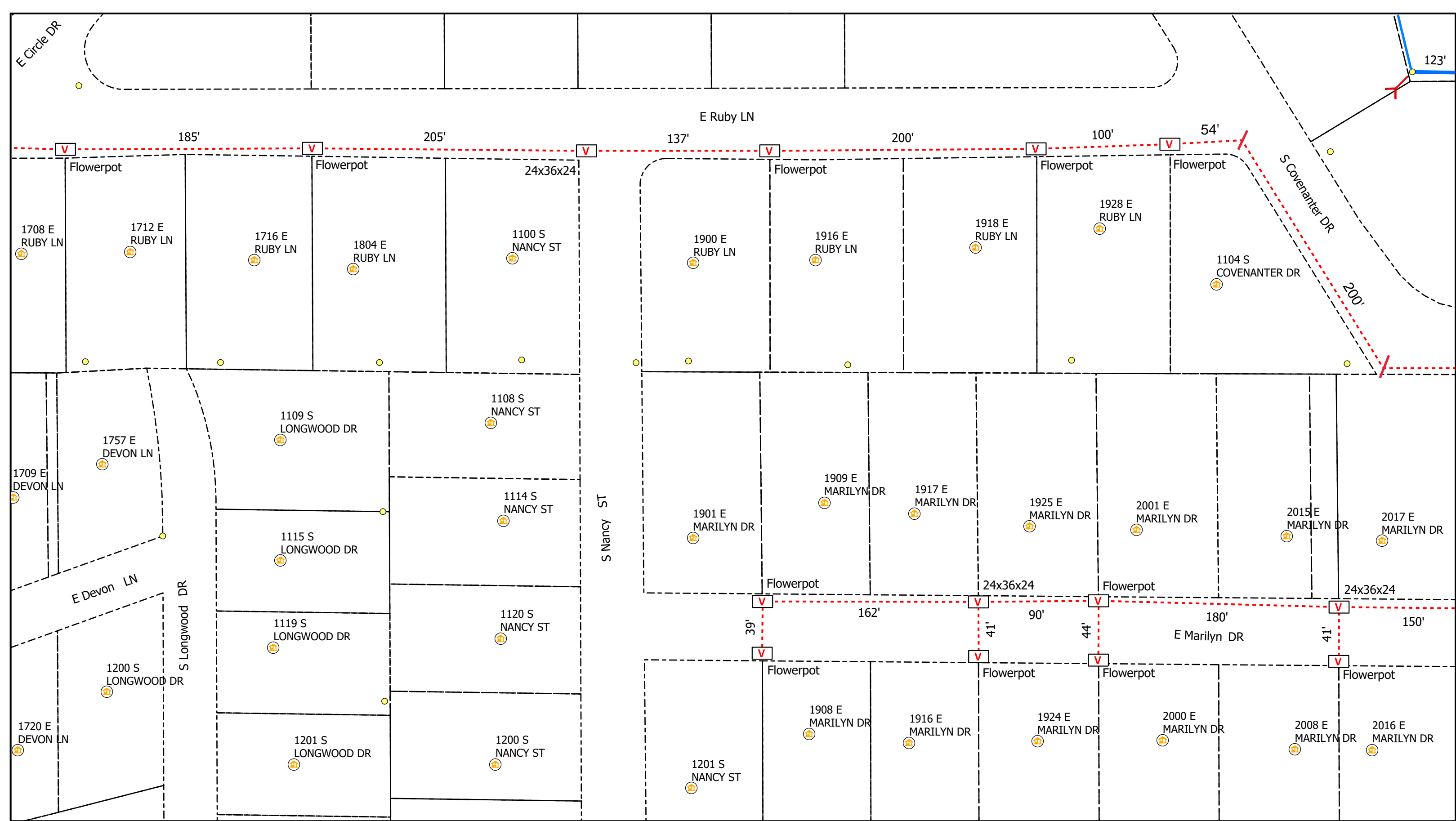

Legend

- Poles
- Overhead Strand
- V Vaults
- - - Conduit
- Bloomington_Parcels
- R Risers
- Address
- Y Anchor
- ← Sidewalk
- Grids

All Flowerpots 12" DIA



City of Bloomington, IN Permit:
Design View

REV	BY	DATE	DESCRIPTION
0	CN	09/27/2022	PERMIT DRAWING



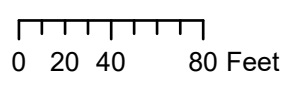
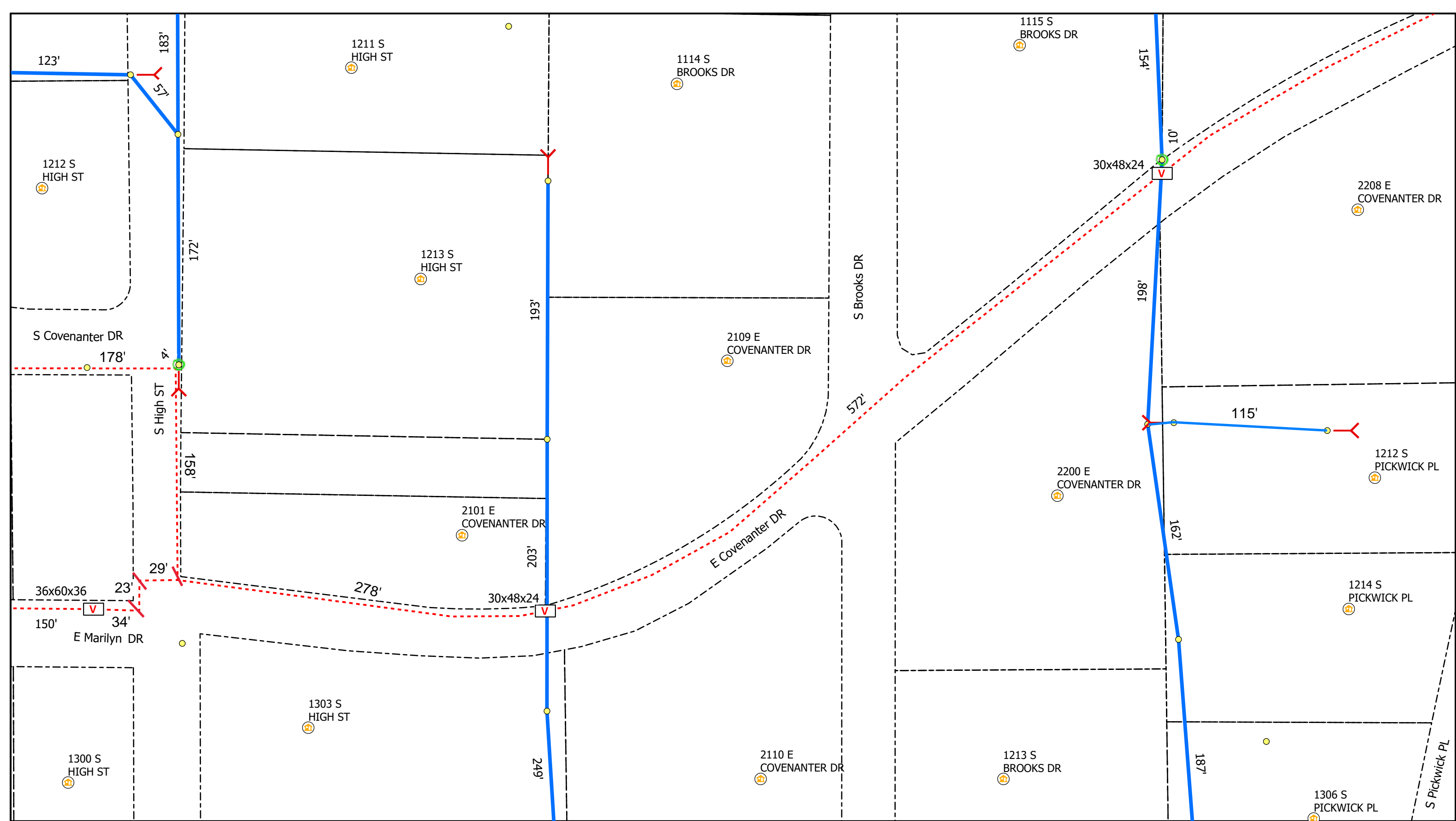

Legend

- Poles
- Overhead Strand
- V Vaults
- Conduit
- Bloomington_Parcels Bloomington_Parcels
- R Risers
- A Address
- Y Anchor
- ← Sidewalk
- Grids Grids

All Flowerpots 12" DIA



City of Bloomington, IN Permit:
Design View

REV	BY	DATE	DESCRIPTION
0	CN	09/27/2022	PERMIT DRAWING





0 20 40 80 Feet

Legend

- Poles
- Overhead Strand
- V Vaults
- - - Conduit
- Bloomington_Parcels
- R Risers
- A Address
- Y Anchor
- ← Sidewalk
- Grids

All Flowerpots 12" DIA

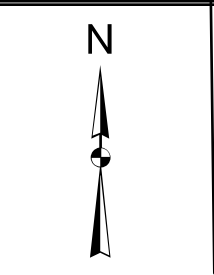

City of Bloomington, IN Permit:
Design View

REV	BY	DATE	DESCRIPTION
0	CN	09/27/2022	PERMIT DRAWING

Print 26 of 29

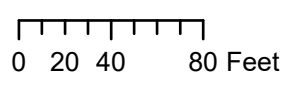

Legend

- Poles
- Overhead Strand
- V Vaults
- - - Conduit
- Bloomington_Parcels
- R Risers
- 🏠 Address
- Y Anchor
- ← Sidewalk
- Grids

All Flowerpots 12" DIA



City of Bloomington, IN Permit:
Design View

REV	BY	DATE	DESCRIPTION
0	CN	09/27/2022	PERMIT DRAWING



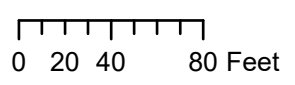
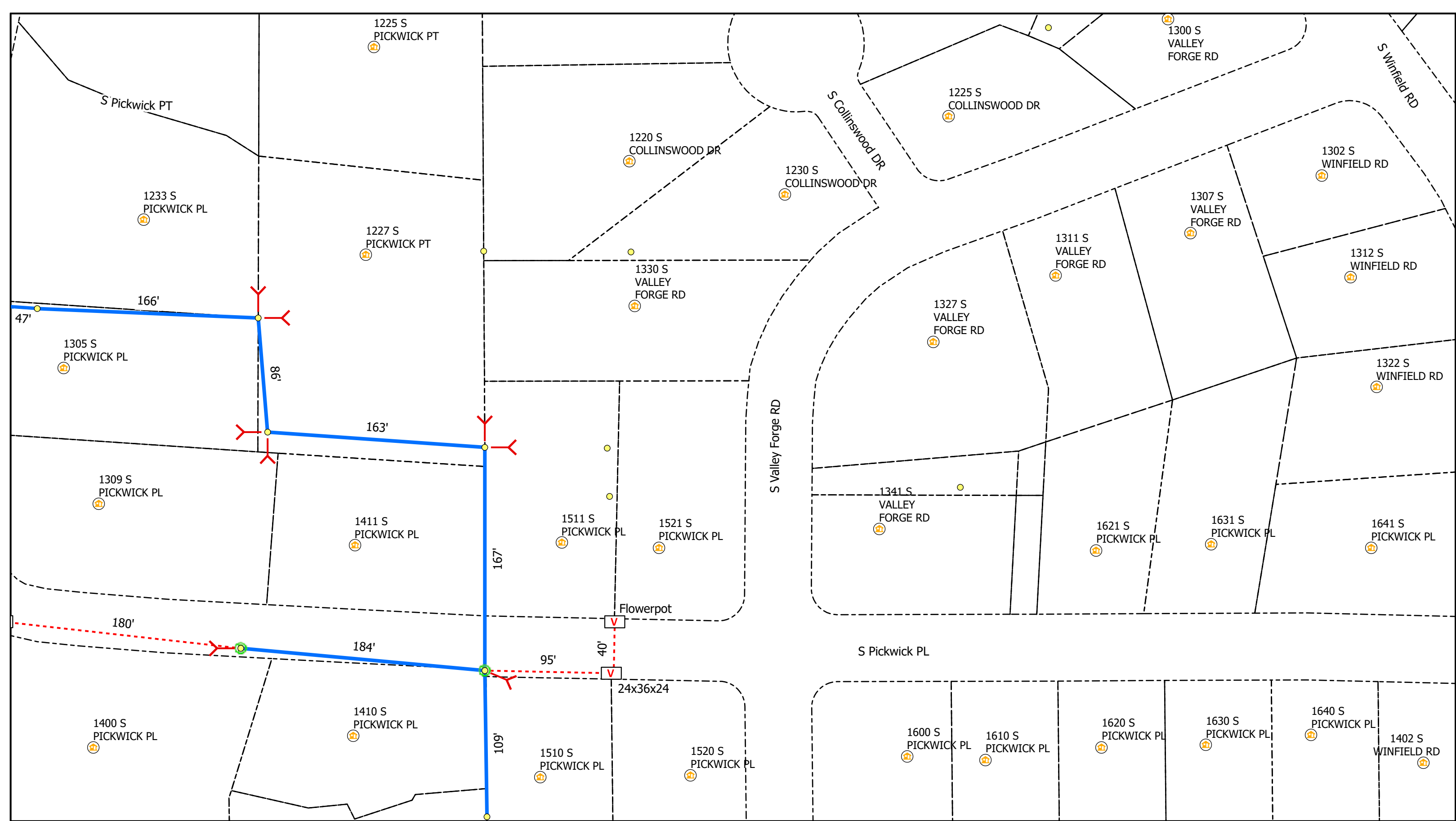

Legend

- Poles
- Overhead Strand
- V Vaults
- Conduit
- Bloomington_Parcels
- R Risers
- Address
- Y Anchor
- ← Sidewalk
- Grids

All Flowerpots 12" DIA



City of Bloomington, IN Permit:
Design View

REV	BY	DATE	DESCRIPTION
0	CN	09/27/2022	PERMIT DRAWING



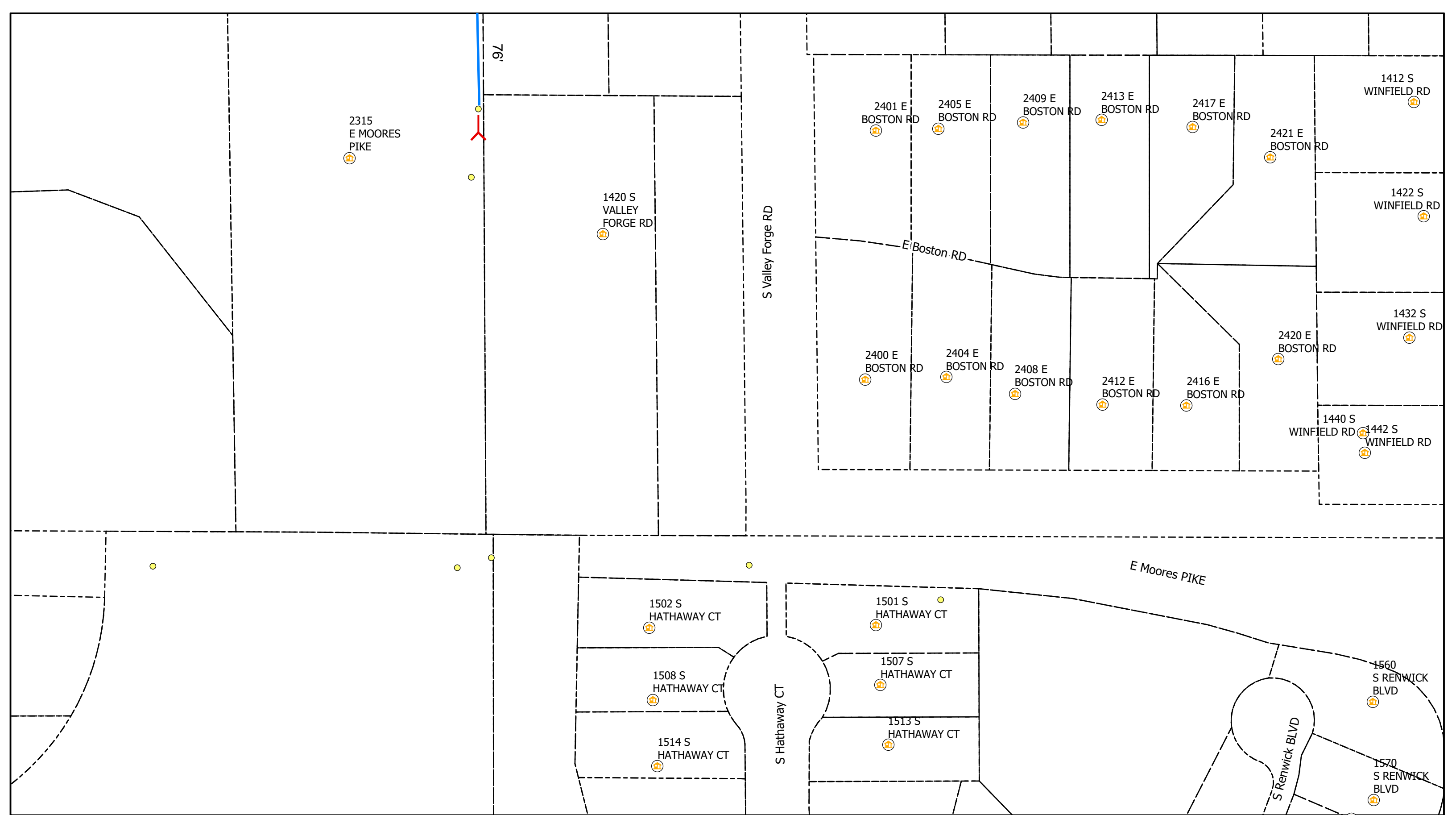

0 20 40 80 Feet

Legend

- Poles
- Overhead Strand
- V Vaults
- - - Conduit
- Bloomington_Parcels
- Ⓡ Risers
- Ⓜ Address
- Y Anchor
- ← Sidewalk
- Grids

All Flowerpots 12" DIA



City of Bloomington, IN Permit:
Design View

REV	BY	DATE	DESCRIPTION
0	CN	09/27/2022	PERMIT DRAWING



Carlton® PV-Mold® Nonmetallic Pole Riser System

Carlton PV-Mold is a nonmetallic pole riser system designed to protect communications power cable installed on poles.

Features:

- Meets or exceeds requirements outlined in the National Electric Safety Code (NESC).
- Designed in accordance with NEMA TC-19 specifications.
- Ultraviolet, cold temperature and corrosive atmosphere resistant.
- Schedule 40 wall meets Schedule 80 PVC conduit impact requirements per NEMA TC-19.
- No grounding required.
- Belled end fits over each added section or conduit.
- Flame retardant.
- Requires no maintenance.
- PV-Mold acts as an insulator against electrical shock.
- Interchangeable parts and accessories to match the needs of specific requirements.



Steel U-Guard requires grounding strapping and does not have belled ends.



PV-Mold has belled ends, flanged design and does not require grounding.

Flanged Overall Length 10 Feet, Including Bell

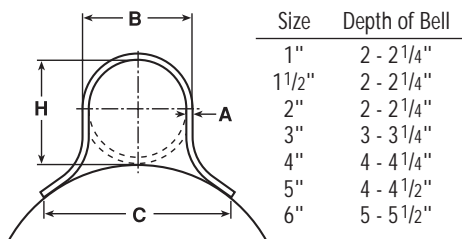

Slots are 1/2" from side to side, and allow for expansion and contraction.

Slot Dimensions: for sizes 2" through 6" are 5/16" wide, 3/4" long.

Slot Dimensions: for 1" and 1 1/2" are 3/16" wide, 3/4" long.

Slot Spacing: 18" from center, beginning 6" from end.

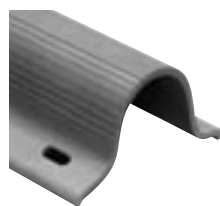

Standard Duty

Part No.	Size	Std. Ctn. Qty.	Std. Ctn. Wt. (lbs.)	Dimensions				Actual Impact @ 0°C 20 Pound Top
				A	B	C	H	
59208N	1"	294	1059	0.100"	1 5/8"	2 3/8"	1 5/8"	40 Ft.-Lbs.
59211N	2"	136	726	0.100"	2 3/8"	4 1/2"	2 3/8"	100 Ft.-Lbs.
59211X (5' length)	2"	136	363	0.100"	2 3/8"	4 1/2"	2 3/8"	100 Ft.-Lbs.
59213N	3"	66	761	0.150"	3 1/2"	6"	3 1/2"	110 Ft.-Lbs.
59213X (5' length)	3"	66	381	0.150"	3 1/2"	6"	3 1/2"	100 Ft.-Lbs.
59215N	4"	65	910	0.150"	4 1/2"	6 1/2"	4 1/2"	110 Ft.-Lbs.
59216N	5"	30	515	0.150"	5 1/2"	7 1/2"	5 1/2"	110 Ft.-Lbs.

Heavy Duty Schedule 40

59010N	1 1/2"	200	1142	0.145"	1 29/32"	3 1/2"	1 29/32"	100 Ft.-Lbs.
59011N	2"	136	1214	0.154"	2 3/8"	4 1/2"	2 3/8"	150 Ft.-Lbs.
59013N	3"	66	937	0.216"	3 1/2"	6"	3 9/32"	150 Ft.-Lbs.
59015N	4"	65	1621	0.237"	4 1/2"	6 1/2"	4 1/2"	260 Ft.-Lbs.
59015X (5' length)	4"	65	707	0.237"	4 1/2"	6 1/2"	4 1/2"	260 Ft.-Lbs.
59016N	5"	30	870	0.258"	5 1/2"	7 1/2"	5 1/2"	260 Ft.-Lbs.
59017N	6"	30	1160	0.280"	6 5/8"	8 3/4"	6 5/8"	260 Ft.-Lbs.

Extra Heavy Duty Schedule 80

59411N	2"	136	1549	0.218"	2 3/8"	4 1/2"	2 3/8"	300 Ft.-Lbs.
59413N	3"	66	1495	0.030"	3 1/2"	6"	3 1/2"	525 Ft.-Lbs.

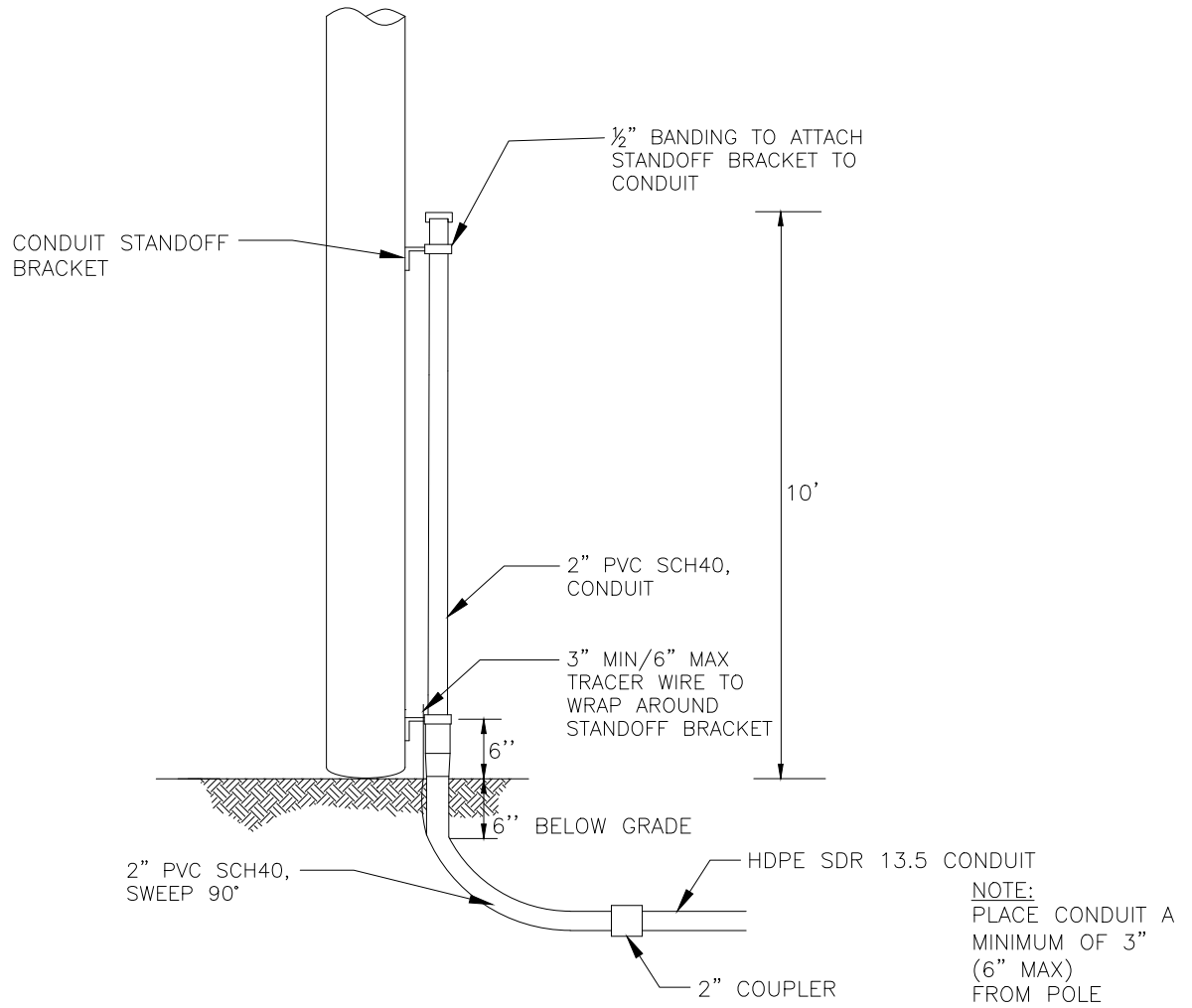

DESCRIPTION

QTY

MANUFACTURER
(PREFERRED)

PART #

SCREW, LAG, 1/2" x 4-1/2"	10		
HDPE SDR 13.5 CONDUIT, VARIOUS SIZES	N/A		
2" PVC SCH40, RISER PIPE	1		
#12 TRACER WIRE	N/A		
2" PVC SCH40, SWEEP, 90 DEG	1		
CONDUIT STANDOFF BRACKET	VARIES		
CONDUIT STRAP KIT	VARIES		
2" COUPLER	1		



TYPICAL RISER
CONDUIT
WOOD POLE

(R2-W)

CONCEPTUAL SIDE VIEW

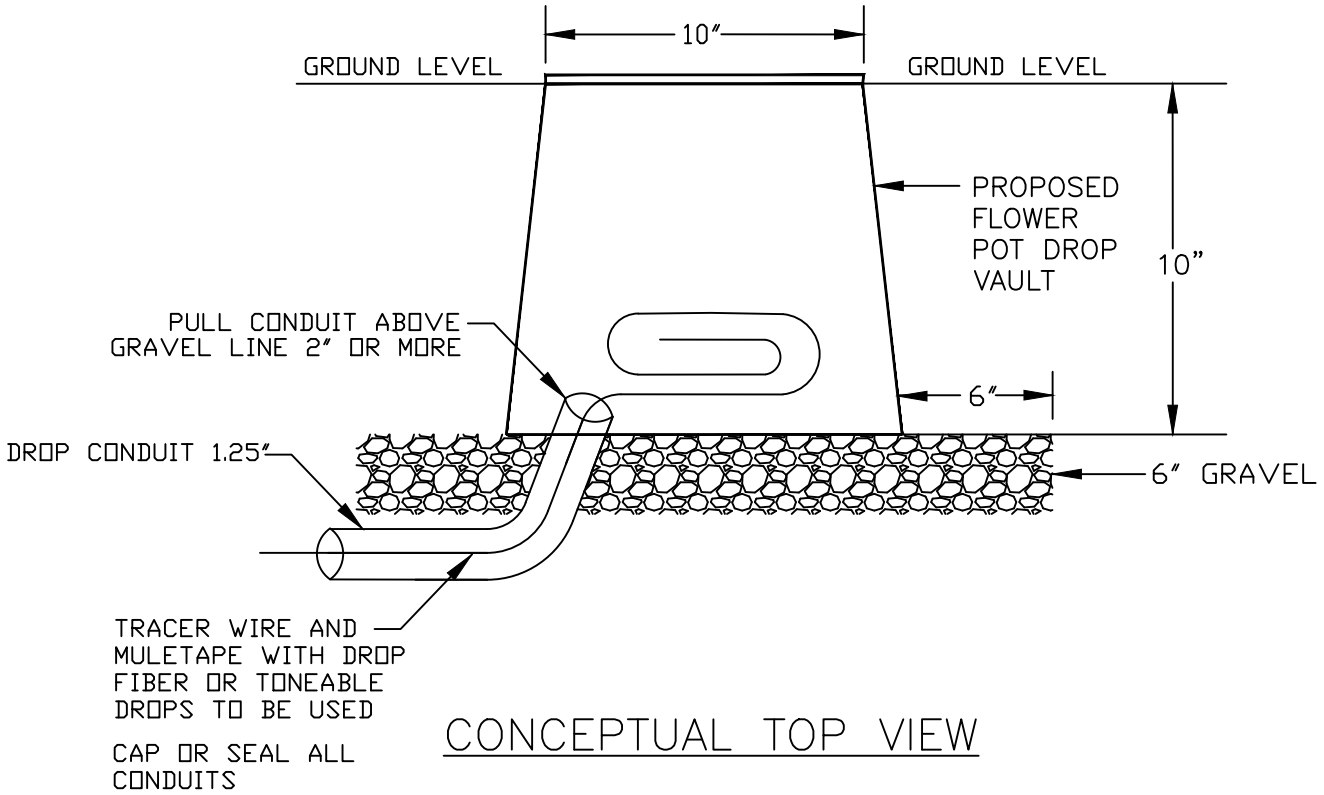

CONCEPTUAL TOP VIEW

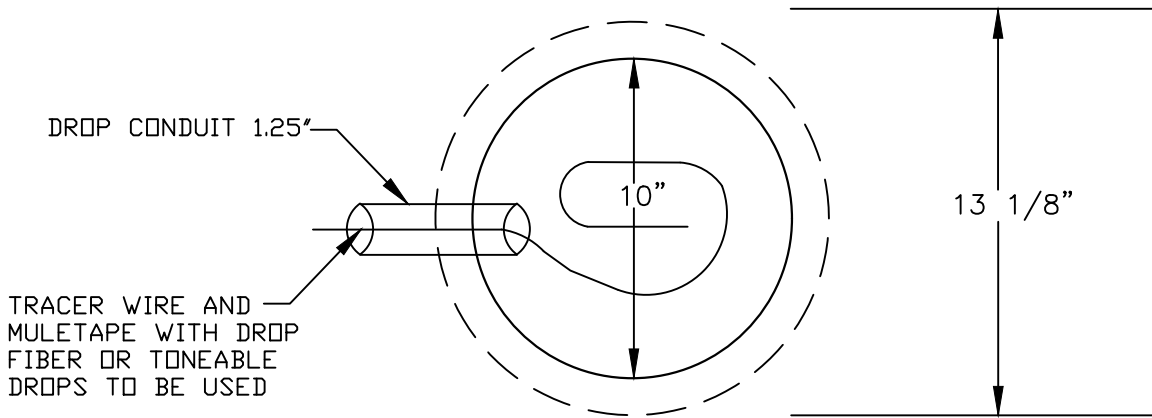

FLOWER POT

30"x48" PC UNIT, 2PC TIER 15/22
 18", 24", and 36" HEIGHT



AMERICAN POLYMER COMPANY

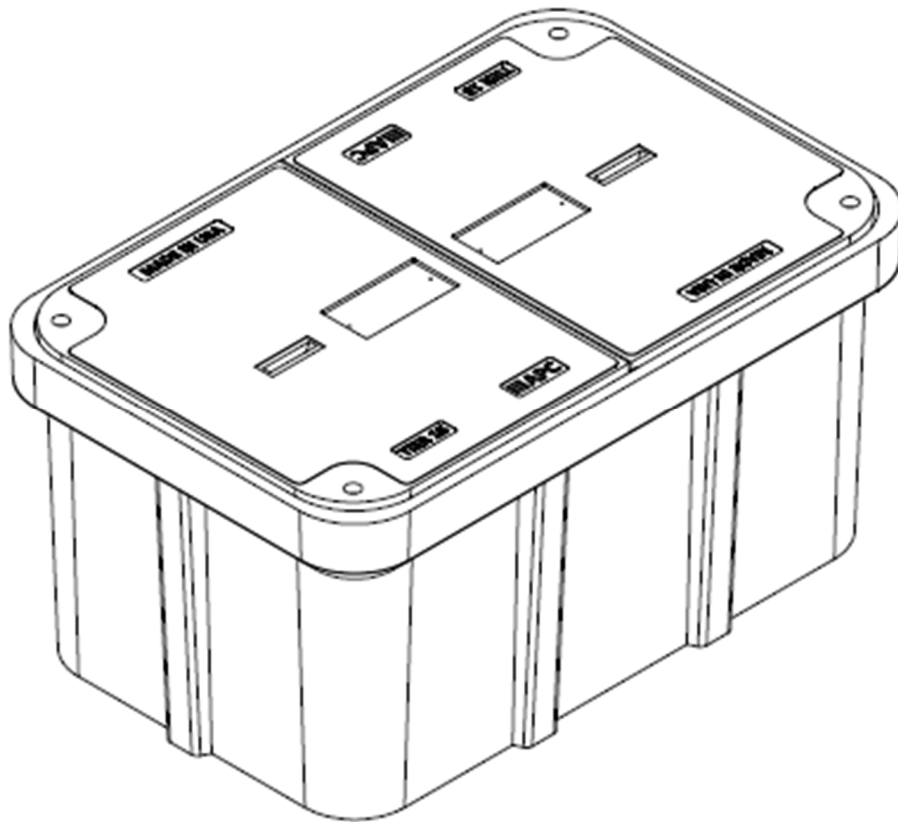

Description	Nominal Size	ANSI Tier	Part Number	Estimated Weight
PC Unit – TIER 15	30"x48"x18"	Tier 15	P304818HU15...	460 lbs.
PC Unit – TIER 22	30"x48"x18"	Tier 22	P304818HU22...	525 lbs.
PC Unit – TIER 15	30"x48"x24"	Tier 15	P304824HU15...	510 lbs.
PC Unit – TIER 22	30"x48"x24"	Tier 22	P304824HU22...	575 lbs.
PC Unit – TIER 15	30"x48"x36"	Tier 15	P304836HU15...	615 lbs.
PC Unit – TIER 22	30"x48"x36"	Tier 22	P304836HU22...	680 lbs.



30"x48" PC UNIT, 2PC TIER 15/22

18", 24", and 36" HEIGHT



AMERICAN POLYMER COMPANY

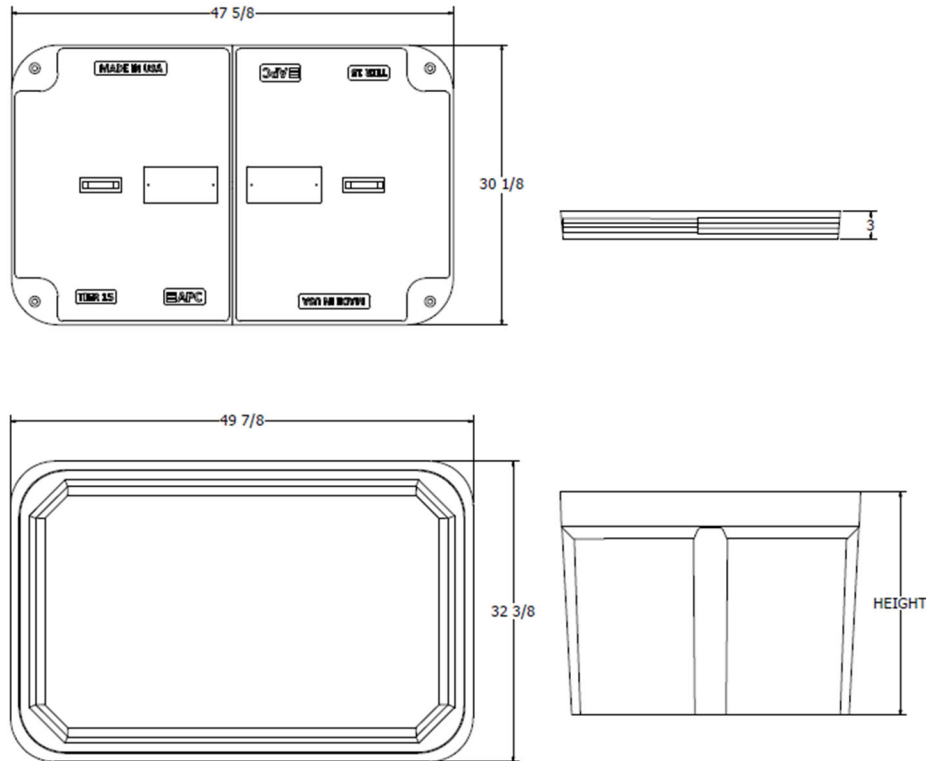

Components	Nominal Size	ANSI Tier	Part Number	Estimated Weight
Replacement Box	30"x48"x18"	Tier 22	P304818B22	185 lbs.
Replacement Box	30"x48"x24"	Tier 22	P304824B22	235 lbs.
Replacement Box	30"x48"x36"	Tier 22	P304836B22	340 lbs.
Replacement Lids - T15	30"x48" (half)	Tier 15	Various	150 lbs.
Replacement Lids - T22	30"x48" (half)	Tier 22	Various	170 lbs.

Bolt options



Machine Thread



Auger Thread



24"x36" PC UNIT, TIER 15/22
 18", 24", 30", and 36" HEIGHT



AMERICAN POLYMER COMPANY

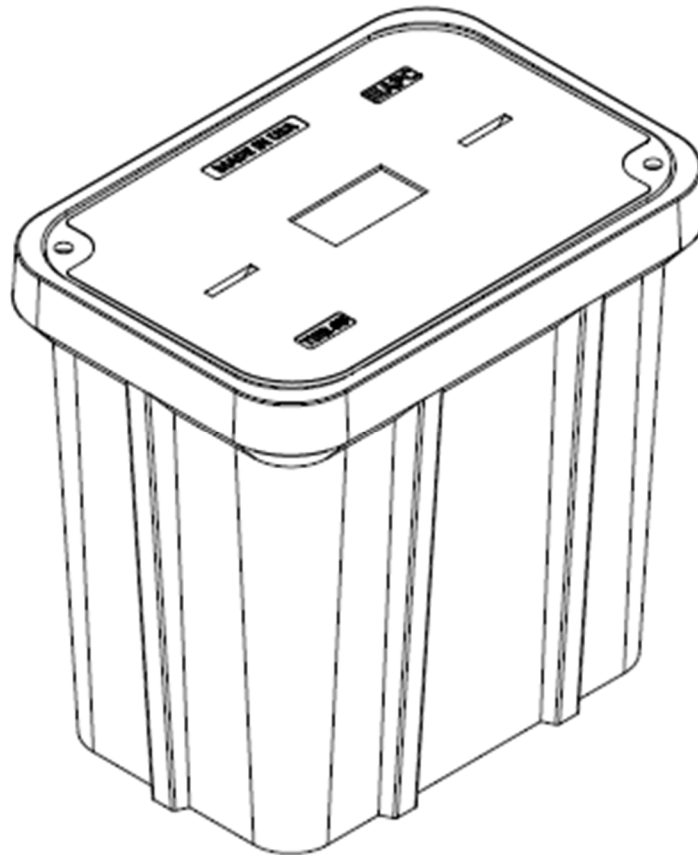

Description	Nominal Size	ANSI Tier	Part Number	Estimated Weight
PC Unit – TIER 15	24x36"x18"	Tier 15	P243618U15...	335 lbs.
PC Unit – TIER 22	24x36"x18"	Tier 22	P243618U22...	355 lbs.
PC Unit – TIER 15	24x36"x24"	Tier 15	P243624U15...	365 lbs.
PC Unit – TIER 22	24x36"x24"	Tier 22	P243624U22...	385 lbs.
PC Unit – TIER 15	24x36"x30"	Tier 15	P243630U15...	395 lbs.
PC Unit – TIER 22	24x36"x30"	Tier 22	P243630U22...	415 lbs.
PC Unit – TIER 15	24x36"x36"	Tier 15	P243636U15...	425 lbs.
PC Unit – TIER 22	24x36"x36"	Tier 22	P243636U22...	445 lbs.



24"x36" PC UNIT, TIER 15/22

18", 24", 30", and 36" HEIGHT



AMERICAN POLYMER COMPANY

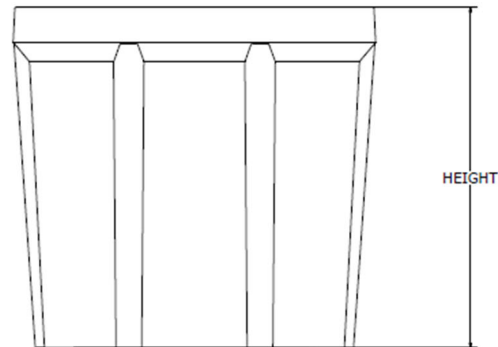
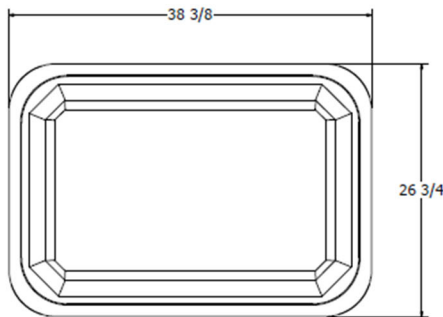
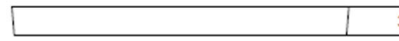
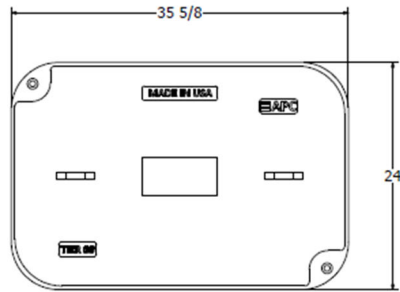

Components	Nominal Size	ANSI Tier	Part Number	Estimated Weight
Replacement Box	24"x36"x18"	Tier 22	P243618B22	165 lbs.
Replacement Box	24"x36"x24"	Tier 22	P243624B22	195 lbs.
Replacement Box	24"x36"x30"	Tier 22	P243630B22	225 lbs.
Replacement Box	24"x36"x36"	Tier 22	P243636B22	255 lbs.
Replacement Lids - T15	24"x36"	Tier 15	Various	170 lbs.
Replacement Lids - T22	24"x36"	Tier 22	Various	190 lbs.

Bolt options

Hex Head



Machine Thread



Penta Head



Auger Thread



33"x60" PC UNIT, 2PC TIER 15/22
36" HEIGHT



AMERICAN POLYMER COMPANY

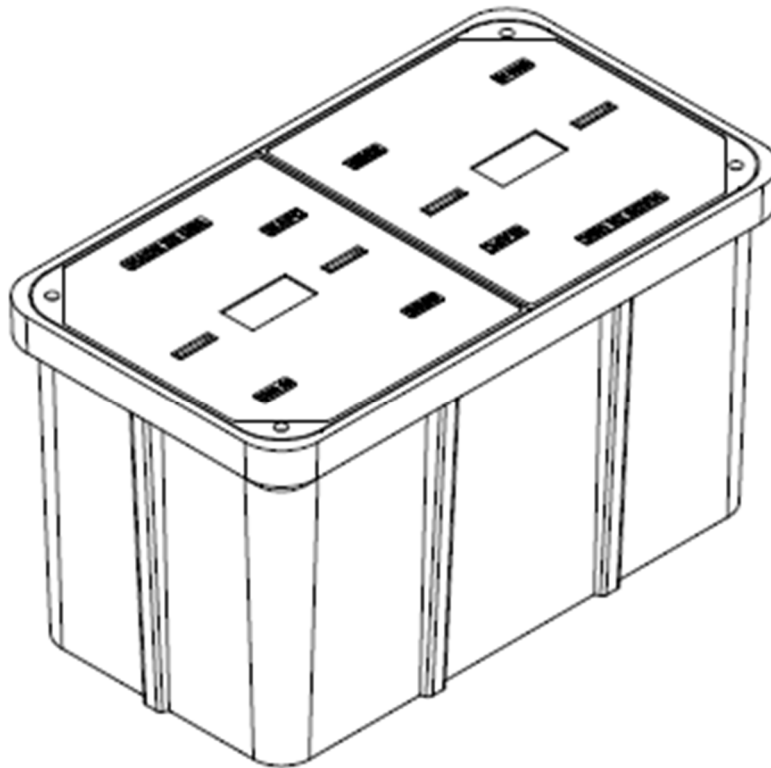

Description	Nominal Size	ANSI Tier	Part Number	Estimated Weight
PC Unit - TIER 15	33"x60"x36"	Tier 15	P336036U15...	930 lbs.
PC Unit - TIER 22	33"x60"x36"	Tier 22	P336036U22...	1030 lbs.



33"x60" PC UNIT, 2PC TIER 15/22

36" HEIGHT



AMERICAN POLYMER COMPANY

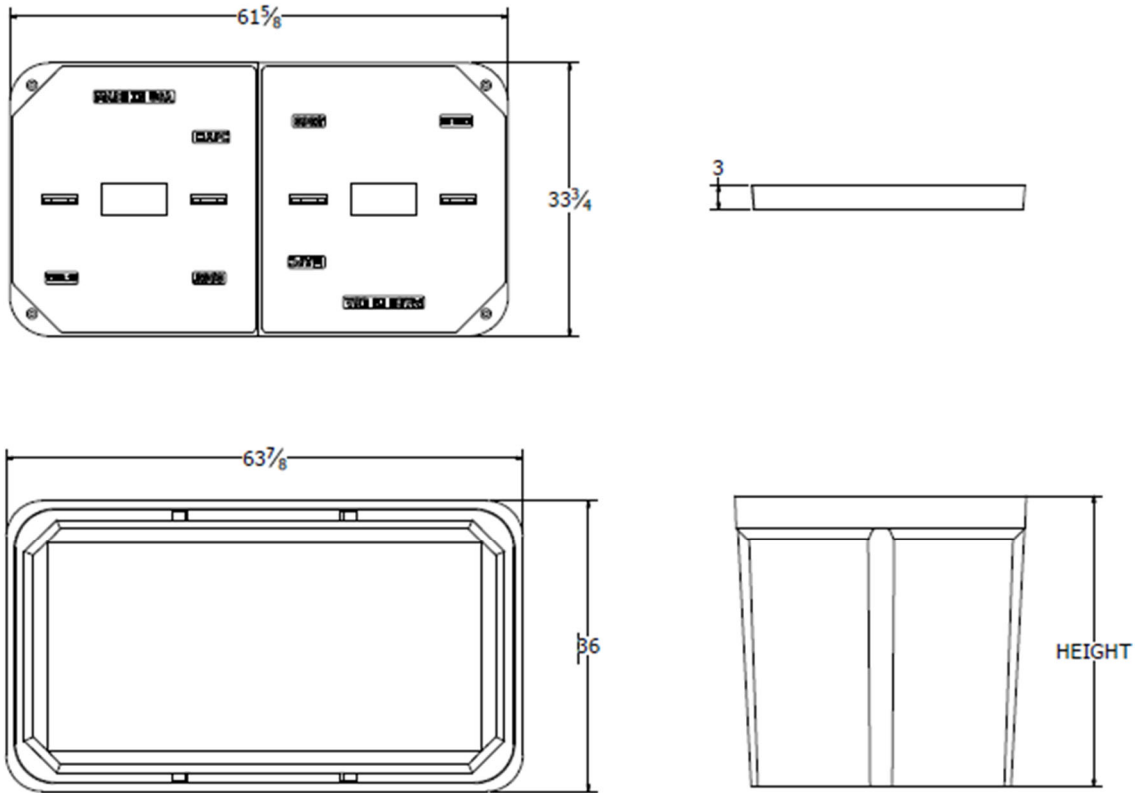

Components	Nominal Size	ANSI Tier	Part Number	Estimated Weight
Replacement Box	33"x60"x36"	Tier 22	P336036B22	530 lbs.
Replacement Lids - T15	33"x60" (half)	Tier 15	Various	200 lbs.
Replacement Lids - T22	33"x60" (half)	Tier 22	Various	250 lbs.

Bolt options

Hex Head



Machine Thread



Penta Head



Auger Thread



Spacing Charts Based on MUTCD		Must be Approved by an Engineer					
Speed (MPH) Prior To Road Work	SIGN SPACING, FT.		BUFFER SPACE, FT.	TAPER LENGTH, FT.	CHANNELIZING SPACING, FT.		
	Non-Divided Highways	Divided Highways	Length	Shoulder (10 ft. Width)	Lane (12 ft. Width)	Through Taper	Through Buffer/Work Area
0-35	200	200	250	70	245	35	50
40-45	350	500	360	150	540	40	80
50-55	500	1000	495	185	660	50	100
60-70	SA-1000, SB-1500, SC-2640		730	235	840	60	120
Urban Low Speed - 100 FT							

APPROVED/ACCEPTED BY:
ENGINEER, OWNER, or PRIME CONTRACTOR
 Check for Notice to Proceed.
BLC01a-F13- TCP

Signature: _____

Company: _____



Date: 9/29/2022 Project: BLC01a-F13- TCP :
: Traffic Control Suggestion For: AEG :
By: Road Runner Safety Services, Inc. : Nathan

Comments:

Drawing not to scale. Traffic control plan must be approved by an engineer. This is a suggestion only. Road Runners Safety Services, Inc. has no liability for this suggested traffic control plan. Actual placement and spacing of all traffic control devices will depend on field conditions and must conform to MUTCD standards.

- Legend**
- ADA Barricade
 - Channelizer
 - Conduit
 - Flagger (Person)
 - Overhead Strand
 - Sign
 - Vault
 - Work Area

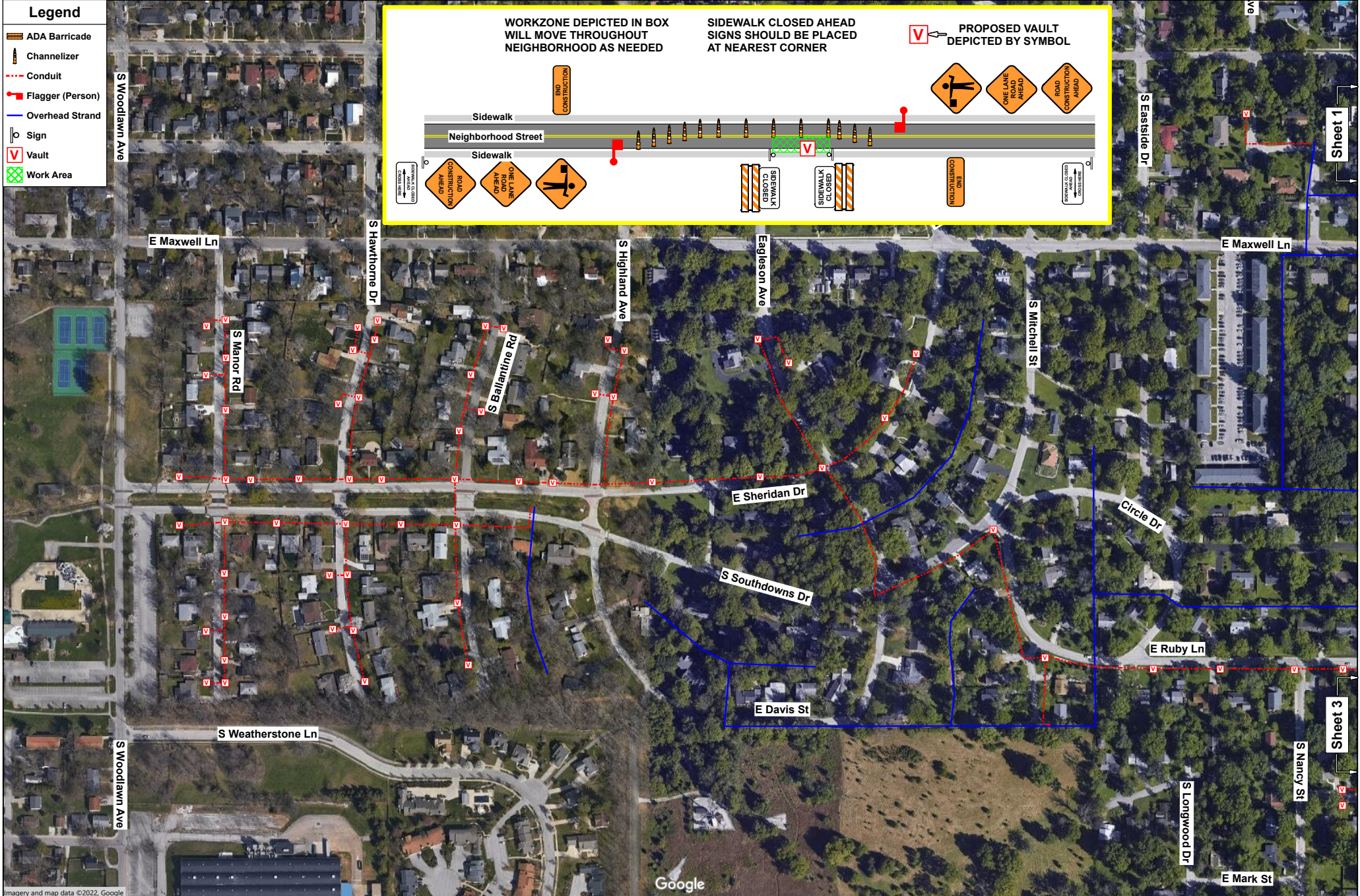
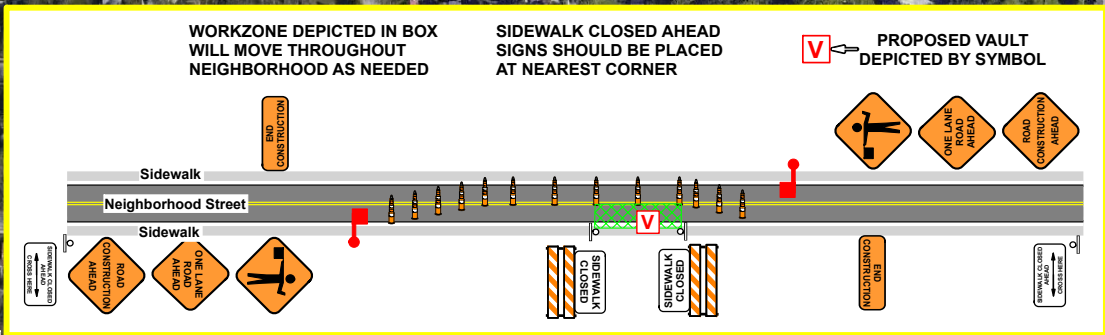

Spacing Charts Based on MUTCD			Must be Approved by an Engineer				
Speed (MPH) Prior To Road Work	SIGN SPACING, FT.		BUFFER SPACE, FT.	TAPER LENGTH, FT.		CHANNELIZING SPACING, FT.	
	Non-Divided Highways	Divided Highways	Length	Shoulder (10 ft. Width)	Lane (12 ft. Width)	Through Taper	Through Buffer/Work Area
0-35	200	200	250	70	245	35	50
40-45	350	500	360	150	540	40	80
50-55	500	1000	495	185	660	50	100
60-70	SA-1000, SB-1500, SC-2640		730	235	840	60	120
Urban Low Speed - 100 FT							

APPROVED/ACCEPTED BY:
ENGINEER, OWNER, or PRIME CONTRACTOR
 Check for Notice to Proceed.
BLC01a-F13- TCP

Signature: _____

Company: _____



Date: 9/29/2022 Project: BLC01a-F13- TCP :
Traffic Control Suggestion For: AEG :
By: Road Runner Safety Services, Inc. : Nathan

Comments:
Drawing not to scale. Traffic control plan must be approved by an engineer. This is a suggestion only. Road Runners Safety Services, Inc. has no liability for this suggested traffic control plan. Actual placement and spacing of all traffic control devices will depend on field conditions and must conform to MUTCD standards.

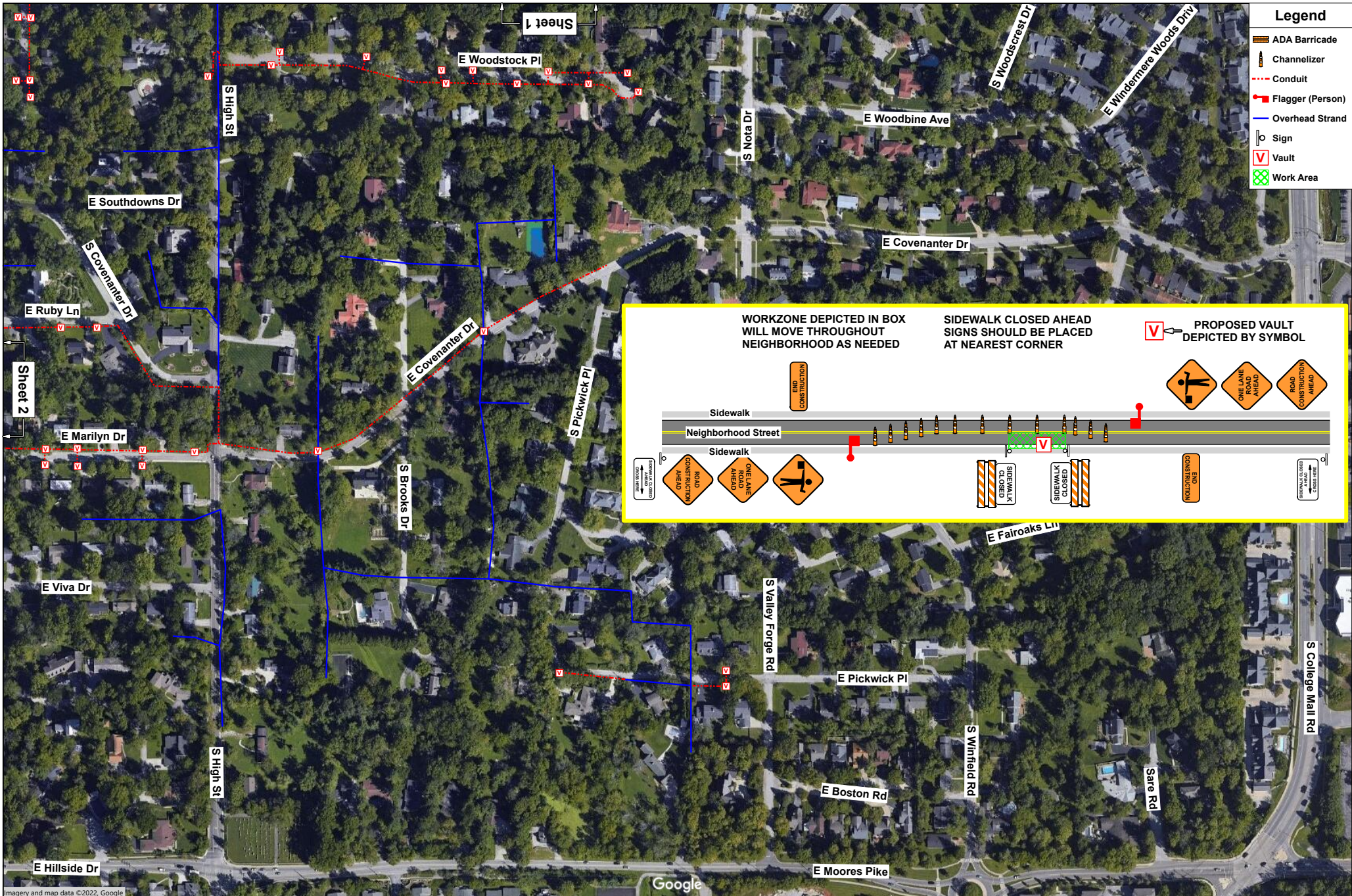



CITY OF BLOOMINGTON RIGHT-OF-WAY USE PERMIT APPLICATION

401 N Morton Street, Suite 130
P.O. Box 100
Bloomington, IN 47402

Phone: (812) 349-3913
Fax: (812) 349-3520
Email:
engineering@bloomington.in.gov

ROW EXCAVATION ROW USE

ADDRESS OF ROW ACTIVITY: E Maxwell Ln

A. APPLICANT/AGENT INFORMATION:		D. TRAFFIC CONTROL DEVICES*:	
APPLICANT NAME: <u>Bret Simons</u>		<input checked="" type="checkbox"/> CONES	<input type="checkbox"/> ARROWBOARD
E-MAIL: <u>bret.simons@aeq.cc</u>		<input type="checkbox"/> LIGHTED BARRELS	<input checked="" type="checkbox"/> TYPE 3 BARRICADES
COMPANY: <u>Atlantic Engineering Group</u>		<input checked="" type="checkbox"/> FLAGGERS	<input type="checkbox"/> BPD OFFICER
ADDRESS: <u>P.O. Box 349</u>		*PROVIDING MUTCD COMPLIANT TEMPORARY TRAFFIC CONTROL DEVICES AND MAINTENANCE OF TRAFFIC (MOT) PLAN IS YOUR RESPONSIBILITY AND REQUIRED. See page 3 for additional MOT resources; the graph paper can be used for your MOT site plan if needed or you can submit a separate sheet	
CITY, STATE, ZIP: <u>Buford, GA 30515</u>		E. METERED PARKING SPACES NEEDED: <input type="checkbox"/> Y <input type="checkbox"/> N	
24-HR EMERGENCY CONTACT NAME: <u>(706)654-2298</u>		IT IS THE RESPONSIBILITY OF THE APPLICANT TO RESERVE PARKING METER(S) APPLICATION LOCATED: https://bloomington.in.gov/transportation/parking/moving OR CONTACT PARKING SERVICES WITH QUESTIONS AT (812)349-3436	
24-HR CONTACT PHONE #: _____		F. IS THIS A <input type="checkbox"/> CBU* <input type="checkbox"/> COUNTY* <input type="checkbox"/> IU* <input type="checkbox"/> NP* PROJECT?	
INSURANCE #*: <u>883724951</u> COMPANY: <u>ACORD</u>		PROJECT NAME: <u>BLC01a-F13 - E Maxwell Ln</u>	
BOND #*: <u>1160465</u> COMPANY: <u>LEXON</u>		PROJECT #: <u>BLC01a-F13 - E Maxwell Ln</u>	
*INSURANCE & BOND MUST BE ON FILE WITH THE CITY BEFORE PERMIT WILL BE ISSUED		PROJECT MGR.: <u>Lex Mullins</u>	
SUBCONTRACTOR INFORMATION		PROJECT MGR. #: <u>215-847-8819</u>	
(LIST ALL COMPANIES WORKING UNDER PRIMARY CONTRACTOR PERMIT)		*CBU = CITY OF BLOOMINGTON UTILITIES *COUNTY = MONROE COUNTY	
COMPANY NAME: _____		*IU = INDIANA UNIVERSITY *NP = NOT-FOR-PROFIT AGENCY	
B. WORK DESCRIPTION:		G. EXCAVATIONS:	
<input type="checkbox"/> POD/DUMPSTER <input type="checkbox"/> CRANE <input type="checkbox"/> SCAFFOLDING <input checked="" type="checkbox"/> CONSTRUCTION USE*		SQ FT OF PAVEMENT* EXCAVATIONS : <u>4 sq ft</u>	
(EXPLAIN): <u>Excavation</u>		*PAVEMENT INCLUDES: IN OR UNDER CONCRETE, OR ASPHALT INCLUDING CURBS	
EXCAVATION, LONG TERM USE FOR STORAGE OF MATERIAL/EQUIPMENT/WALKAROUND		SQ FT OF NON-PAVEMENT EXCAVATIONS: <u>369 sq ft</u>	
C. RIGHT OF WAY TO BE USED/CLOSED:		*DIRT, GRASS, GRAVEL, LANDSCAPE AREA OR OTHER UNPAVED SURFACE	
STREET NAME 1: <u>E Maxwell Ln</u>		LINEAL FT OF BORE*: <u>18,649 Lineal Ft</u>	
1ST INTERSECTING STREET NAME: _____		*BORE PITS SHALL BE CALCULATED AS SQ FT EXCAVATIONS	
2ND INTERSECTING STREET NAME: _____		# OF POLE INSTALLATIONS/REMOVAL: <u>N/A</u>	
<input type="checkbox"/> ROAD CLOSURE <input checked="" type="checkbox"/> LANE CLOSURE 1 <input checked="" type="checkbox"/> 2 <input type="checkbox"/> 3 <input type="checkbox"/>		SQ FT OF SIDEWALK RECONSTRUCTION*: <u>N/A</u>	
<input checked="" type="checkbox"/> SIDEWALK* <input type="checkbox"/> BIKE LANE <input type="checkbox"/> OTHER		*CONCRETE OR ASPHALT SIDEWALK/PATH BEING IMPROVED/REPLACED	
TRANSIT STOP? <input type="checkbox"/> Y <input type="checkbox"/> N PARKING LANE(S)** <input type="checkbox"/> Y <input type="checkbox"/> N **NON-METERED		SQ FT OF SIDEWALK NEW CONSTRUCTION*: <u>N/A</u>	
START DATE: <u>Oct 14th</u> END DATE: _____ # OF DAYS*: <u>30</u>		*CONCRETE OR ASPHALT SIDEWALK/PATH THAT IS NEW INFRASTRUCTURE	
STREET NAME 2: _____		# RESIDENTIAL DRIVEWAY INSTALLATION: <u>N/A</u>	
1ST INTERSECTING STREET NAME: _____		 <p>TO SUBMIT A LOCATE REQUEST 24 HRS A DAY, 7 DAYS A WEEK CALL 811 OR 800-382-5544 CALL 2 WORKING DAYS BEFORE YOU DIG. ITS THE LAW.</p>	
2ND INTERSECTING STREET NAME: _____			
<input type="checkbox"/> ROAD CLOSURE <input type="checkbox"/> LANE CLOSURE 1 <input type="checkbox"/> 2 <input type="checkbox"/> 3 <input type="checkbox"/>		H. INDEMNIFICATION AGREEMENT:	
<input type="checkbox"/> SIDEWALK* <input type="checkbox"/> BIKE LANE <input type="checkbox"/> OTHER		The petitioner/applicant hereby agrees to hold harmless, defend and to indemnify the City of Bloomington from or against all claims, action, damages and expenses, including but not limited to reasonable attorney's fees or any alleged injury and/or death to any person or damage to any property arising, or alleged to have arisen out of any act of commission or omission on the part of the petitioner/applicant, his/her heirs, successors, or assigns regardless of whether such acts are the direct or indirect result of the public right-of-way use pursuant to this permit grant.	
TRANSIT STOP? <input type="checkbox"/> Y <input type="checkbox"/> N PARKING LANE(S)** <input type="checkbox"/> Y <input type="checkbox"/> N **NON-METERED		I AFFIRM, UNDER THE PENALTIES FOR PERJURY, THAT THE FOREGOING REPRESENTATIONS ARE TRUE.	
START DATE: _____ END DATE: _____ # OF DAYS*: _____		PRINT NAME: <u>Bret Simons</u>	
*SIDEWALK CLOSURES FOR A PERIOD OR PERIODS TOTALING 24HRS OR MORE SHALL INSTALL A WALKAROUND UNLESS OTHERWISE APPROVED DURING REVIEW		SIGNATURE: <u>Bret Simons</u>	
STANDARD CLOSURE HOURS MON-FRI*: 9:00 AM - 3:00 PM & 6:00 PM - 9:00 PM		DATE: <u>9/20/2022</u>	
STANDARD CLOSURE HOURS <input checked="" type="checkbox"/> *NON-STANDARD CLOSURE HOURS <input type="checkbox"/>			
REQUESTED CLOSURE HOURS: _____ AM - _____ PM			
*non-standard hours may not be allowed near schools, on arterials, or other circumstances and are subject to approval during the permitting process			
BMC 14.09.040 allows work from 6 AM to 10 PM without violating the noise ordinance (7AM to 9PM for pneumatic hammers)			

For Administration Use Only (applicable to CLOSURE approval)

Approved By: _____ BPW City Engineer Director Date: _____

Staff Representative: _____ Phone#: _____ Date: _____

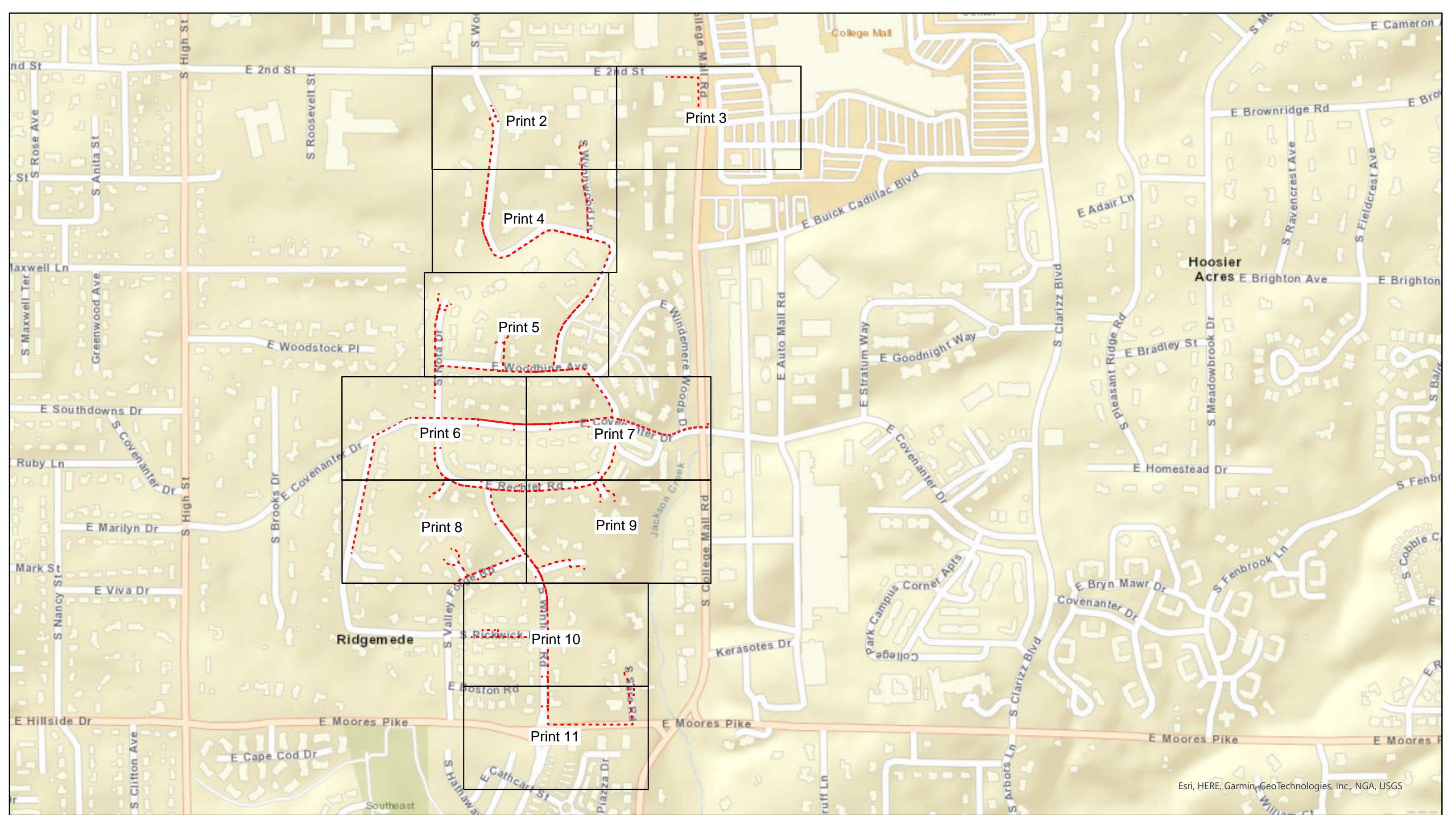

Esri, HERE, Garmin, GeoTechnologies, Inc., NGA, USGS



Legend BLC01a-F14 - S Woodcrest Dr

- - - Conduit
- Grids

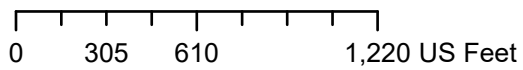

City of Bloomington, IN Permit:
Design View

INI	BY	DATE	DESCRIPTION



E 2nd ST

600 S
WOODSCREST DR

601 S
WOODSCREST DR

611 S
WOODSCREST DR

628 S
WOODSCREST DR

629 S
WOODSCREST DR

648 S
WOODSCREST DR

2520 E 2ND ST

2604 E 2ND ST

2606 E 2ND ST

2602 E 2ND ST

702 S
WYNNWOOD LN

703 S
WYNNWOOD LN

S Woodcrest DR

S Wynnwood LN

Flowerpot

Flowerpot

Flowerpot

Flowerpot

71'

40'

38'

379'

322'

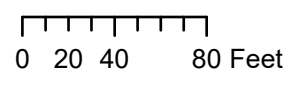

Legend

- Poles
- Vaults
- Overhead Strand
- Conduit
- Bloomington_Parcels
- Risers
- Address
- Anchor
- Sidewalk

All Flowerpots 12" DIA



City of Bloomington, IN Permit:
Design View

INI	BY	DATE	DESCRIPTION



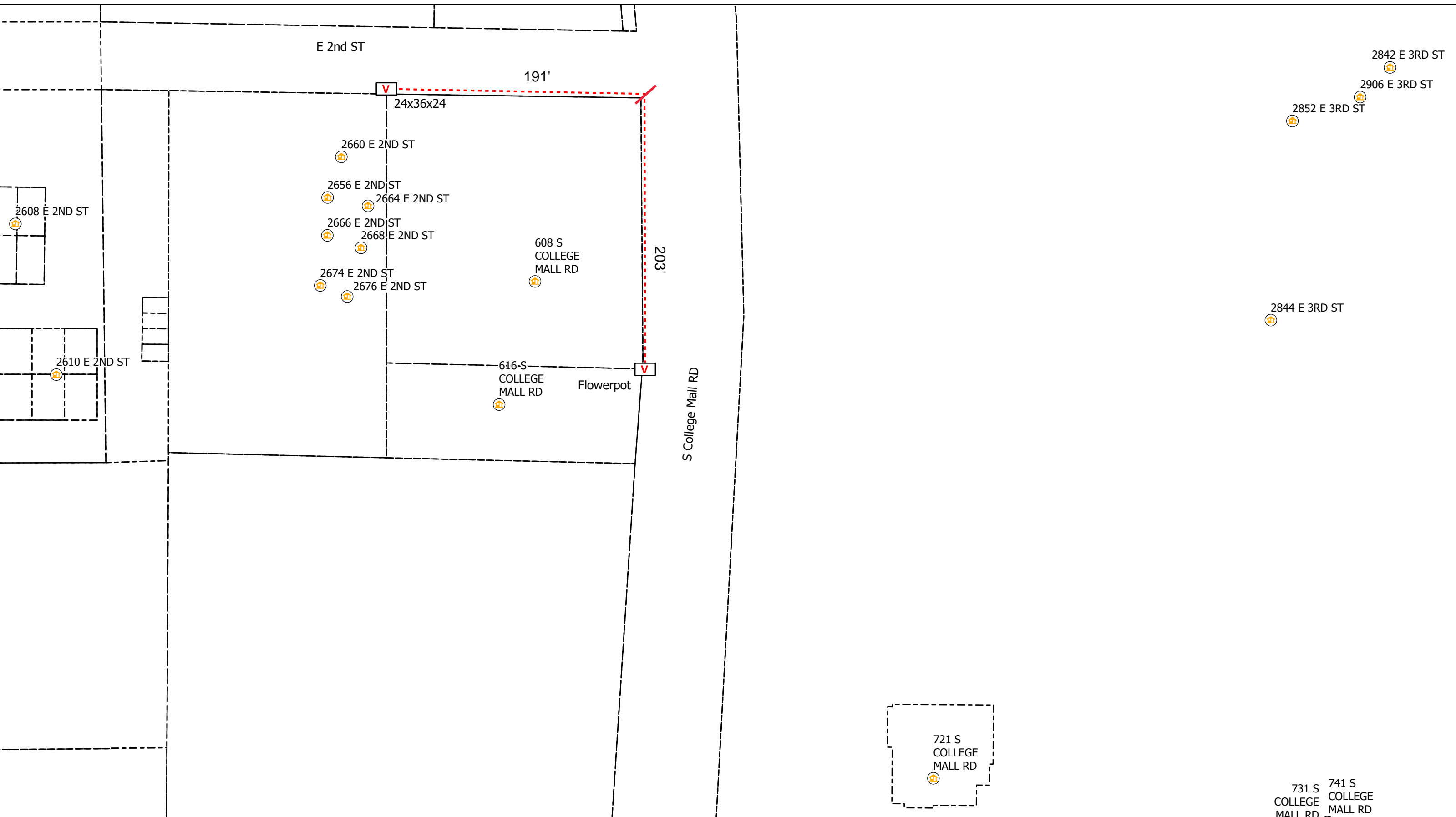

- Legend**
- Poles
 - V Vaults
 - Overhead Strand
 - - - Conduit
 - Bloomington_Parcels
 - Ⓡ Risers
 - Ⓜ Address
 - Y Anchor
 - ↖ Sidewalk

All Flowerpots 12" DIA



City of Bloomington, IN Permit:
Design View

INI	BY	DATE	DESCRIPTION



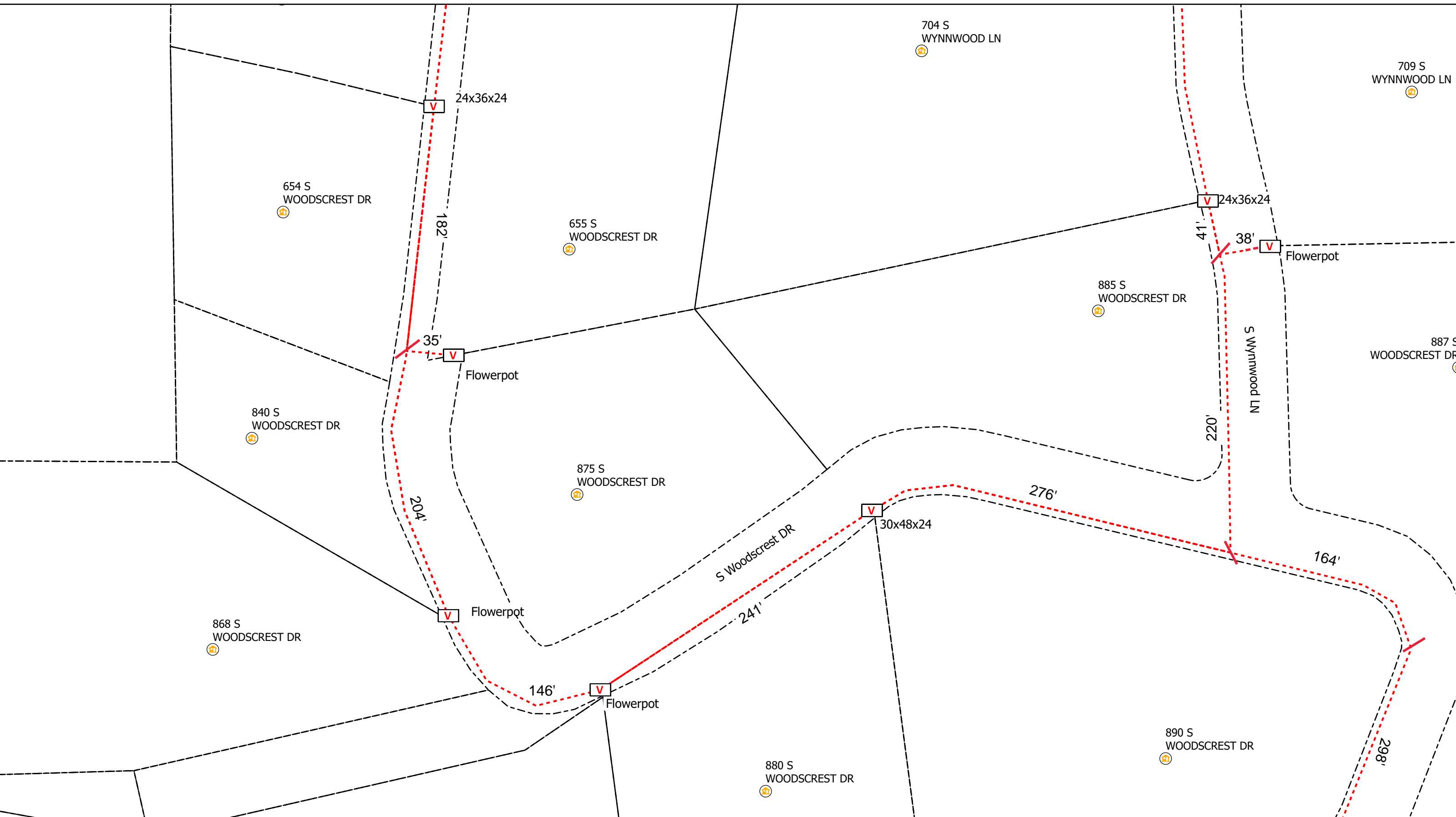

0 20 40 80 Feet

Legend

- Poles
- V Vaults
- Overhead Strand
- Conduit
- Bloomington_Parcels
- R Risers
- 123 Address
- Y Anchor
- ↖ Sidewalk

All Flowerpots 12" DIA

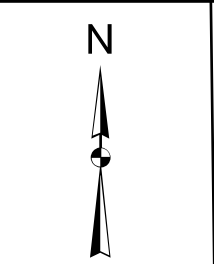

City of Bloomington, IN Permit:
Design View

INI	BY	DATE	DESCRIPTION

Print 4 of 11

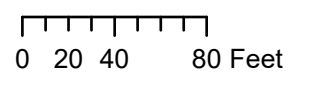
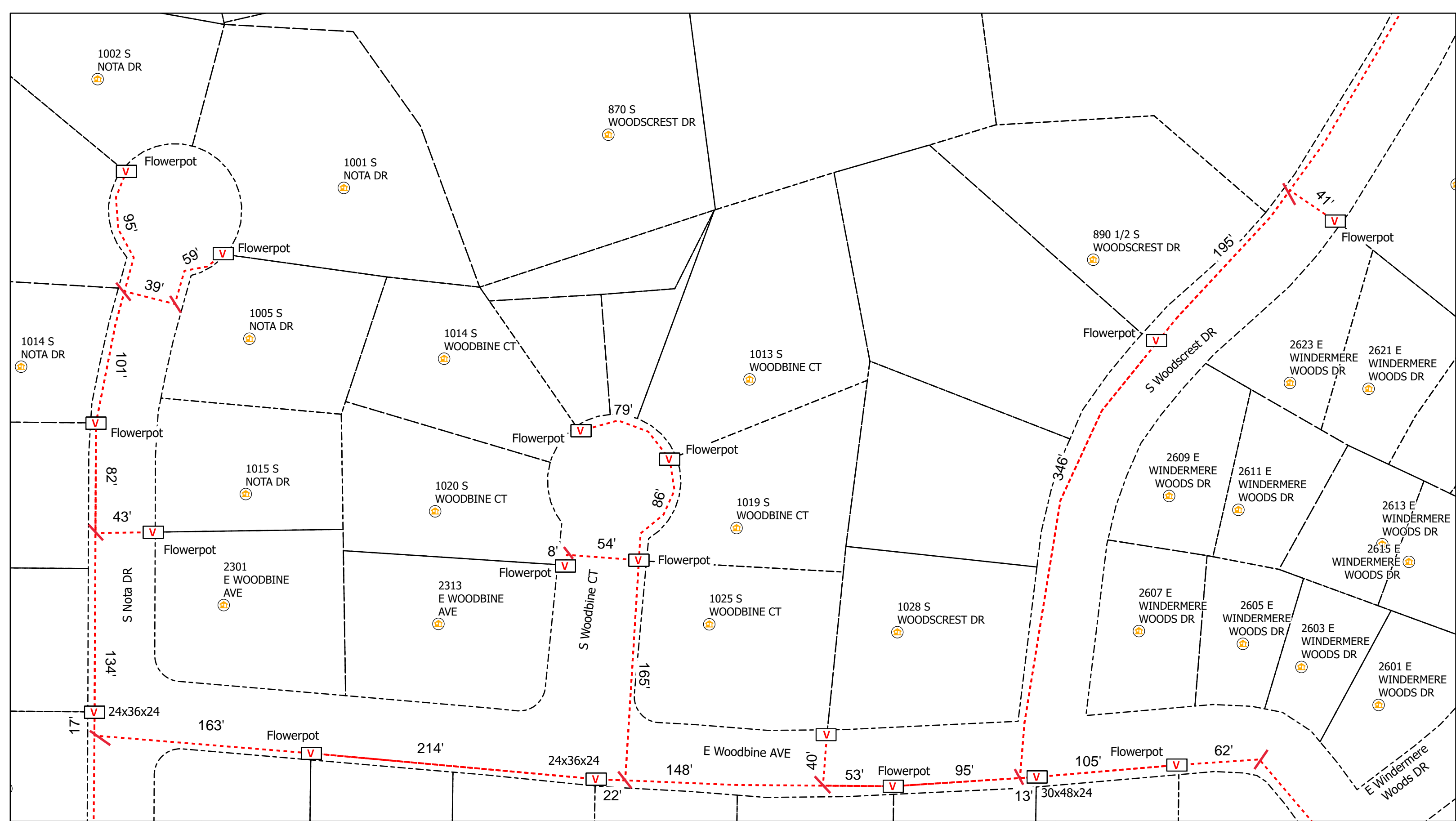

Legend

- Poles
- V Vaults
- Overhead Strand
- Conduit
- Bloomington_Parcels
- R Risers
- Address
- Y Anchor
- ↖ Sidewalk

All Flowerpots 12" DIA



City of Bloomington, IN Permit:
Design View

INI	BY	DATE	DESCRIPTION



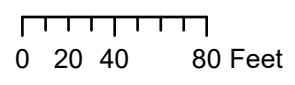
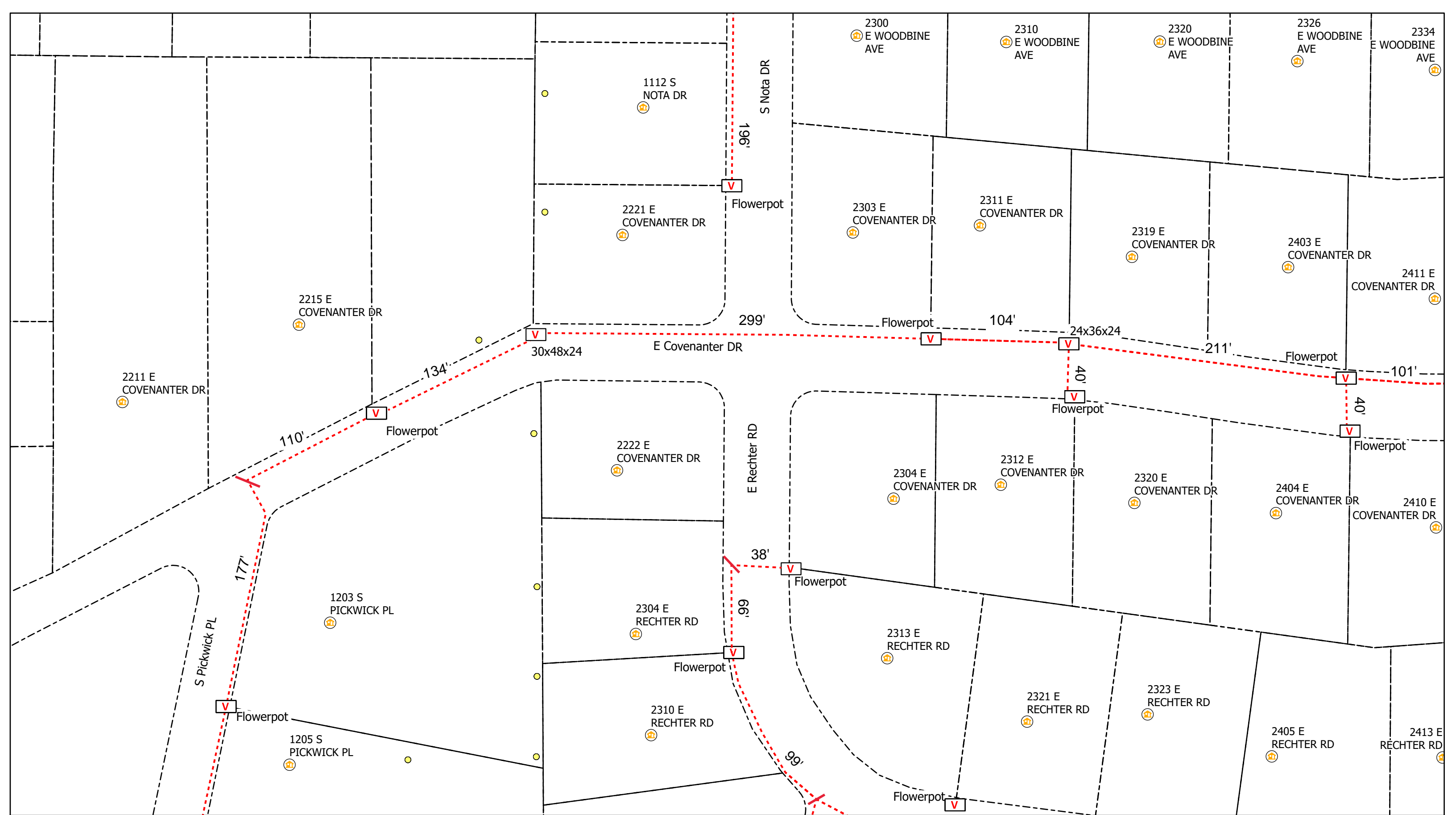

Legend

- Poles
- V Vaults
- Overhead Strand
- Conduit
- Bloomington_Parcels
- R Risers
- A Address
- Y Anchor
- ↖ Sidewalk

All Flowerpots 12" DIA



City of Bloomington, IN Permit:
Design View

INI	BY	DATE	DESCRIPTION



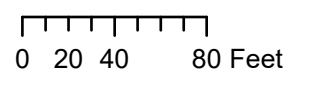
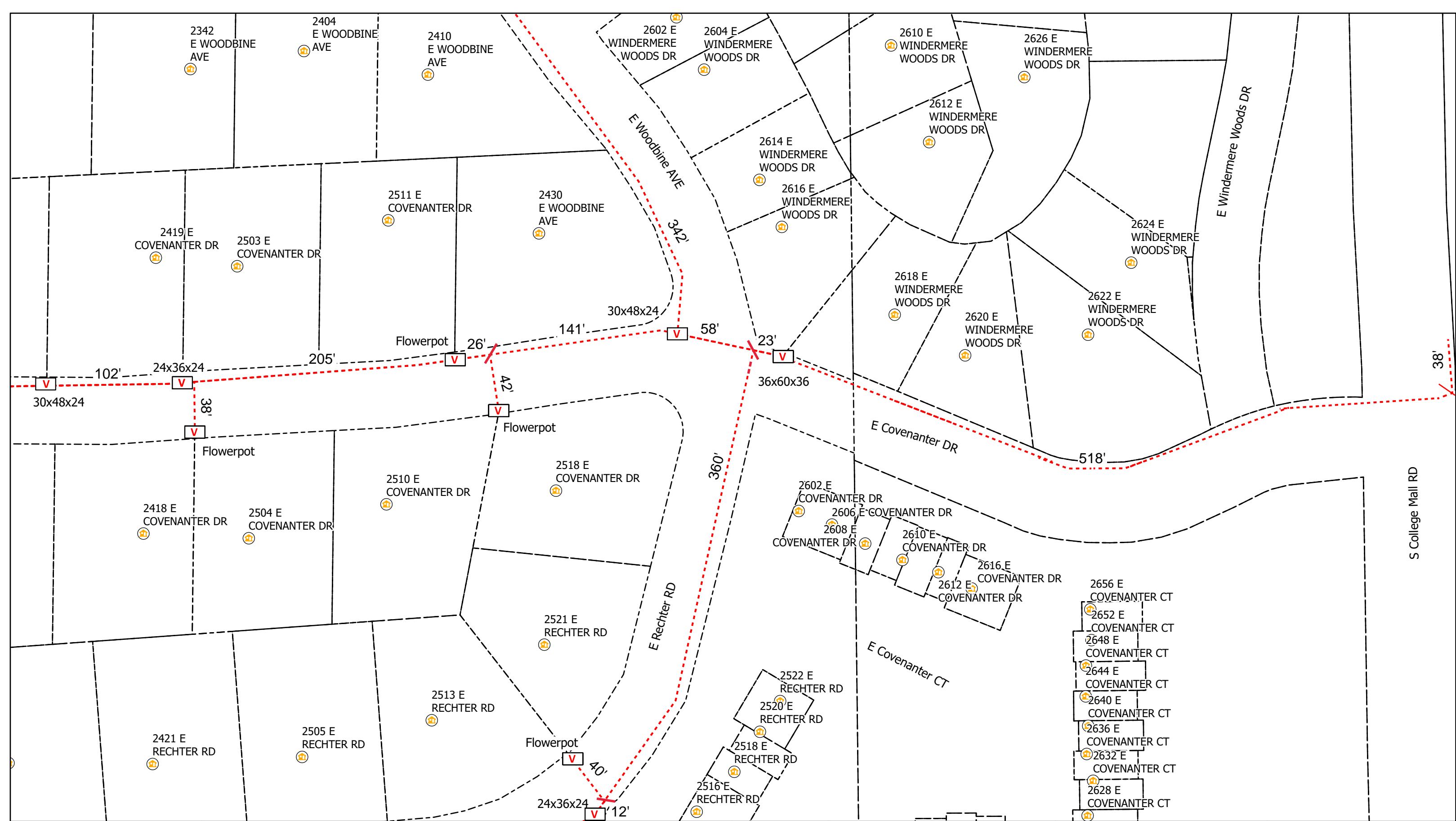

Legend

- Poles
- V Vaults
- Overhead Strand
- Conduit
- Bloomington_Parcels
- R Risers
- H Address
- Y Anchor
- └ Sidewalk

All Flowerpots 12" DIA



City of Bloomington, IN Permit:
Design View

INI	BY	DATE	DESCRIPTION



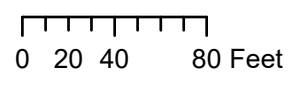
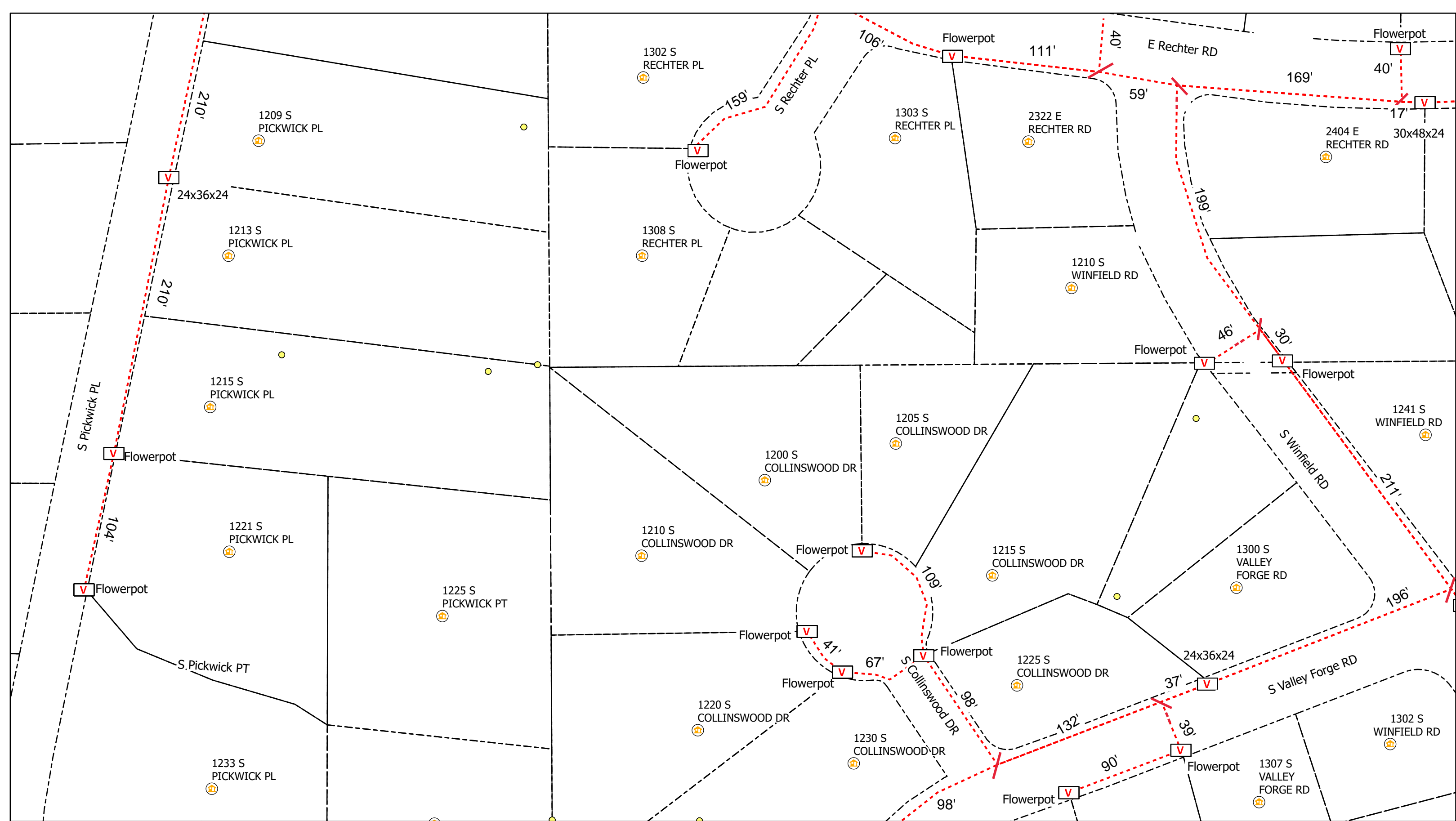

Legend

- Poles
- V Vaults
- Overhead Strand
- Conduit
- Bloomington_Parcels
- R Risers
- A Address
- Y Anchor
- ↖ Sidewalk

All Flowerpots 12" DIA



City of Bloomington, IN Permit:
Design View

INI	BY	DATE	DESCRIPTION



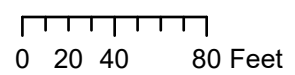
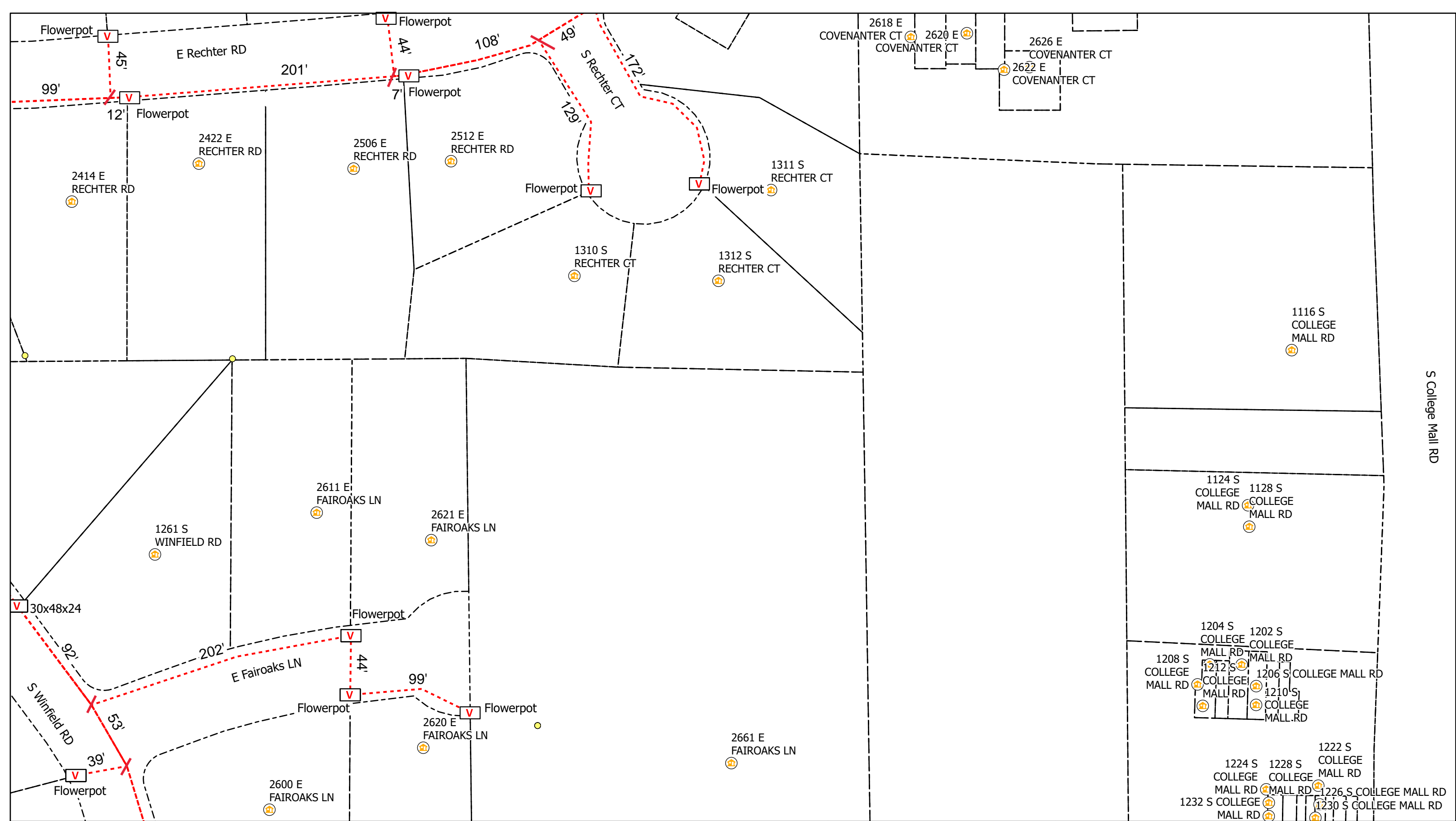

Legend

- Poles
- V Vaults
- Overhead Strand
- Conduit
- Bloomington_Parcels
- R Risers
- A Address
- Y Anchor
- ↖ Sidewalk

All Flowerpots 12" DIA



City of Bloomington, IN Permit:
Design View

INI	BY	DATE	DESCRIPTION



S College Mall Rd

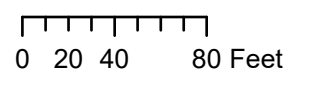
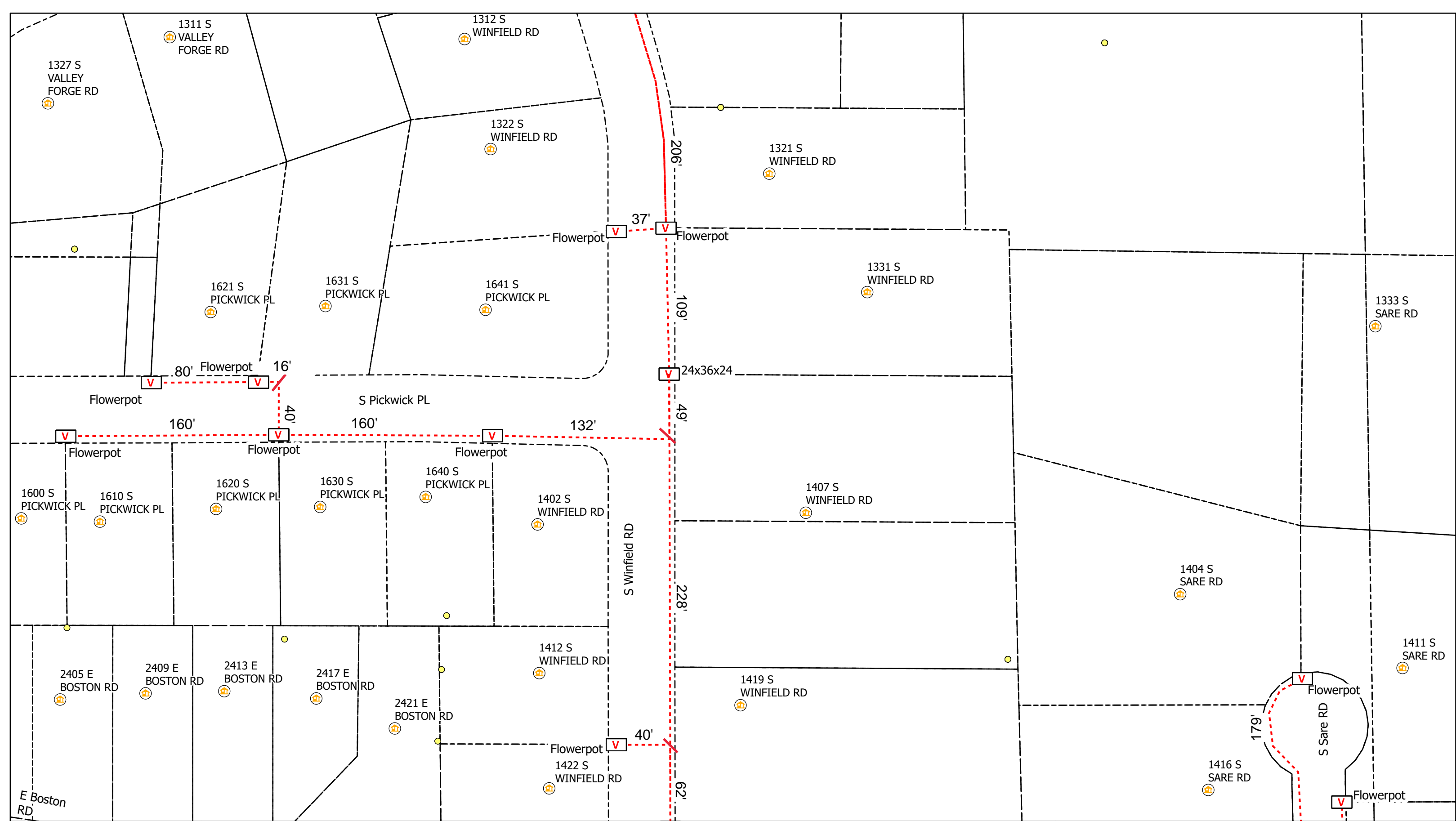

Legend

- Poles
- V Vaults
- Overhead Strand
- Conduit
- Bloomington Parcels
- R Risers
- A Address
- Y Anchor
- ⤴ Sidewalk

All Flowerpots 12" DIA



City of Bloomington, IN Permit:
Design View

INI	BY	DATE	DESCRIPTION



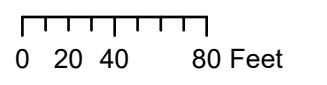
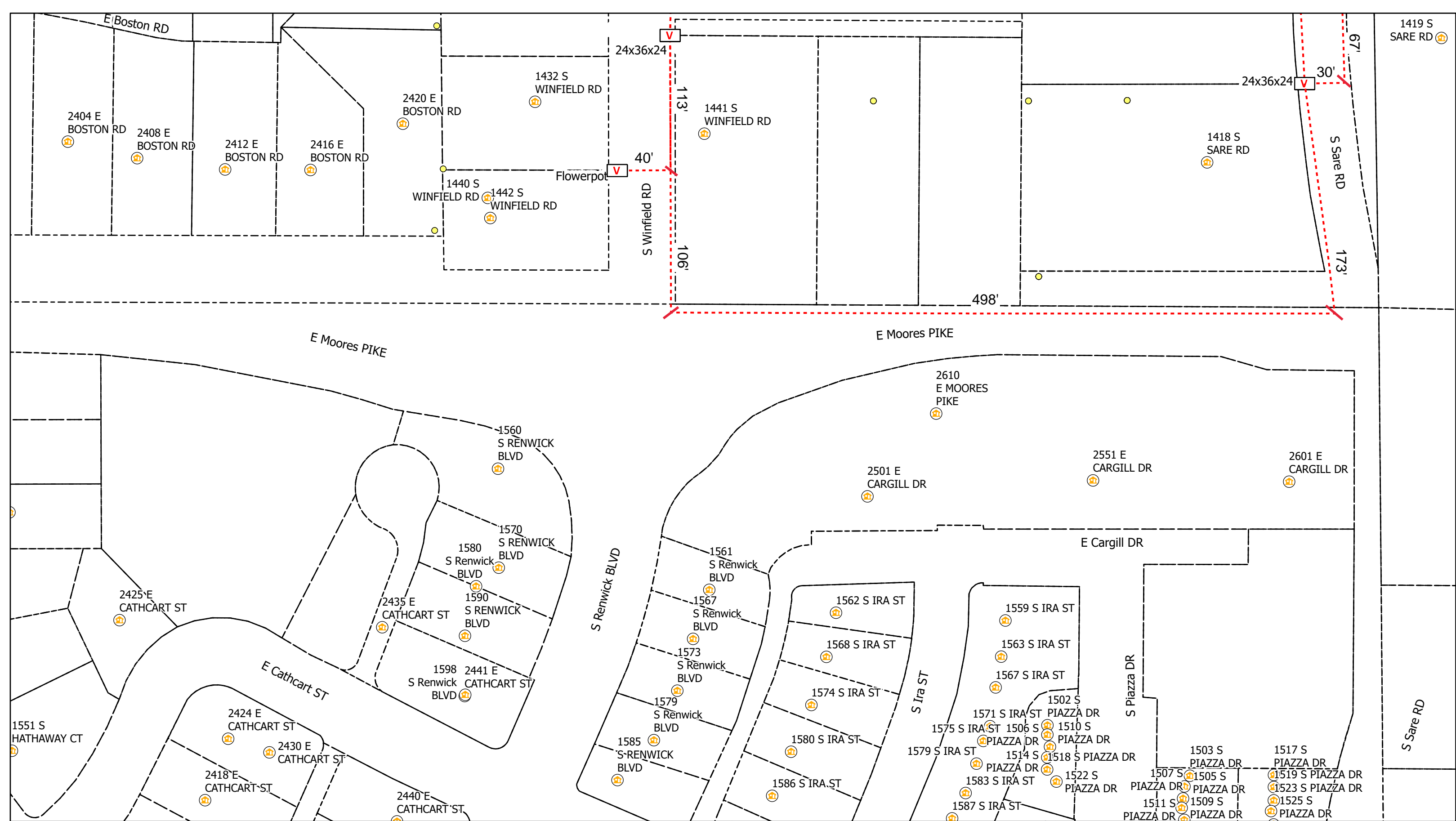

Legend

- Poles
- V Vaults
- Overhead Strand
- Conduit
- Bloomington_Parcels
- R Risers
- A Address
- Y Anchor
- ⤴ Sidewalk

All Flowerpots 12" DIA



City of Bloomington, IN Permit:
Design View

INI	BY	DATE	DESCRIPTION



Carlton® PV-Mold® Nonmetallic Pole Riser System

Carlton PV-Mold is a nonmetallic pole riser system designed to protect communications power cable installed on poles.

Features:

- Meets or exceeds requirements outlined in the National Electric Safety Code (NESC).
- Designed in accordance with NEMA TC-19 specifications.
- Ultraviolet, cold temperature and corrosive atmosphere resistant.
- Schedule 40 wall meets Schedule 80 PVC conduit impact requirements per NEMA TC-19.
- No grounding required.
- Belled end fits over each added section or conduit.
- Flame retardant.
- Requires no maintenance.
- PV-Mold acts as an insulator against electrical shock.
- Interchangeable parts and accessories to match the needs of specific requirements.



Steel U-Guard requires grounding strapping and does not have belled ends.



PV-Mold has belled ends, flanged design and does not require grounding.

Flanged Overall Length 10 Feet, Including Bell

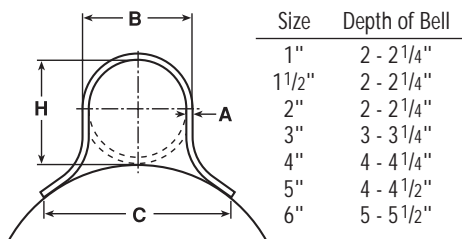

Slots are 1/2" from side to side, and allow for expansion and contraction.

Slot Dimensions: for sizes 2" through 6" are 5/16" wide, 3/4" long.

Slot Dimensions: for 1" and 1 1/2" are 3/16" wide, 3/4" long.

Slot Spacing: 18" from center, beginning 6" from end.

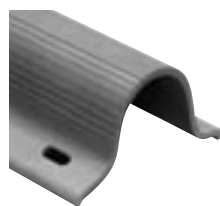

Standard Duty

Part No.	Size	Std. Ctn. Qty.	Std. Ctn. Wt. (lbs.)	Dimensions				Actual Impact @ 0°C 20 Pound Top
				A	B	C	H	
59208N	1"	294	1059	0.100"	1 5/8"	2 3/8"	1 5/8"	40 Ft.-Lbs.
59211N	2"	136	726	0.100"	2 3/8"	4 1/2"	2 3/8"	100 Ft.-Lbs.
59211X (5' length)	2"	136	363	0.100"	2 3/8"	4 1/2"	2 3/8"	100 Ft.-Lbs.
59213N	3"	66	761	0.150"	3 1/2"	6"	3 1/2"	110 Ft.-Lbs.
59213X (5' length)	3"	66	381	0.150"	3 1/2"	6"	3 1/2"	100 Ft.-Lbs.
59215N	4"	65	910	0.150"	4 1/2"	6 1/2"	4 1/2"	110 Ft.-Lbs.
59216N	5"	30	515	0.150"	5 1/2"	7 1/2"	5 1/2"	110 Ft.-Lbs.

Heavy Duty Schedule 40

59010N	1 1/2"	200	1142	0.145"	1 29/32"	3 1/2"	1 29/32"	100 Ft.-Lbs.
59011N	2"	136	1214	0.154"	2 3/8"	4 1/2"	2 3/8"	150 Ft.-Lbs.
59013N	3"	66	937	0.216"	3 1/2"	6"	3 9/32"	150 Ft.-Lbs.
59015N	4"	65	1621	0.237"	4 1/2"	6 1/2"	4 1/2"	260 Ft.-Lbs.
59015X (5' length)	4"	65	707	0.237"	4 1/2"	6 1/2"	4 1/2"	260 Ft.-Lbs.
59016N	5"	30	870	0.258"	5 1/2"	7 1/2"	5 1/2"	260 Ft.-Lbs.
59017N	6"	30	1160	0.280"	6 5/8"	8 3/4"	6 5/8"	260 Ft.-Lbs.

Extra Heavy Duty Schedule 80

59411N	2"	136	1549	0.218"	2 3/8"	4 1/2"	2 3/8"	300 Ft.-Lbs.
59413N	3"	66	1495	0.030"	3 1/2"	6"	3 1/2"	525 Ft.-Lbs.

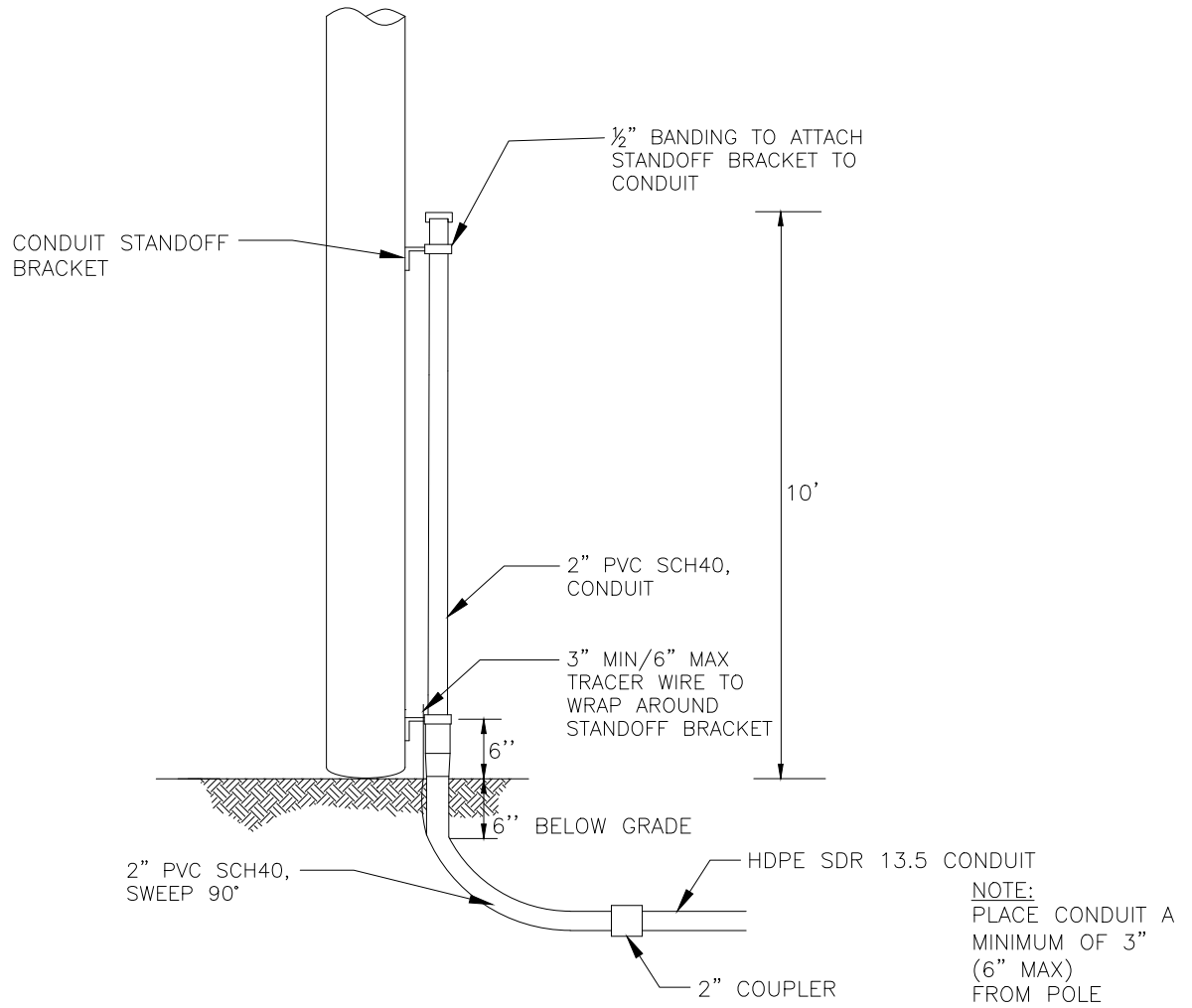

DESCRIPTION	QTY	MANUFACTURER (PREFERRED)	PART #
SCREW, LAG, 1/2" x 4-1/2"	10		
HDPE SDR 13.5 CONDUIT, VARIOUS SIZES	N/A		
2" PVC SCH40, RISER PIPE	1		
#12 TRACER WIRE	N/A		
2" PVC SCH40, SWEEP, 90 DEG	1		
CONDUIT STANDOFF BRACKET	VARIES		
CONDUIT STRAP KIT	VARIES		
2" COUPLER	1		



TYPICAL RISER
CONDUIT
WOOD POLE

(R2-W)

CONCEPTUAL SIDE VIEW

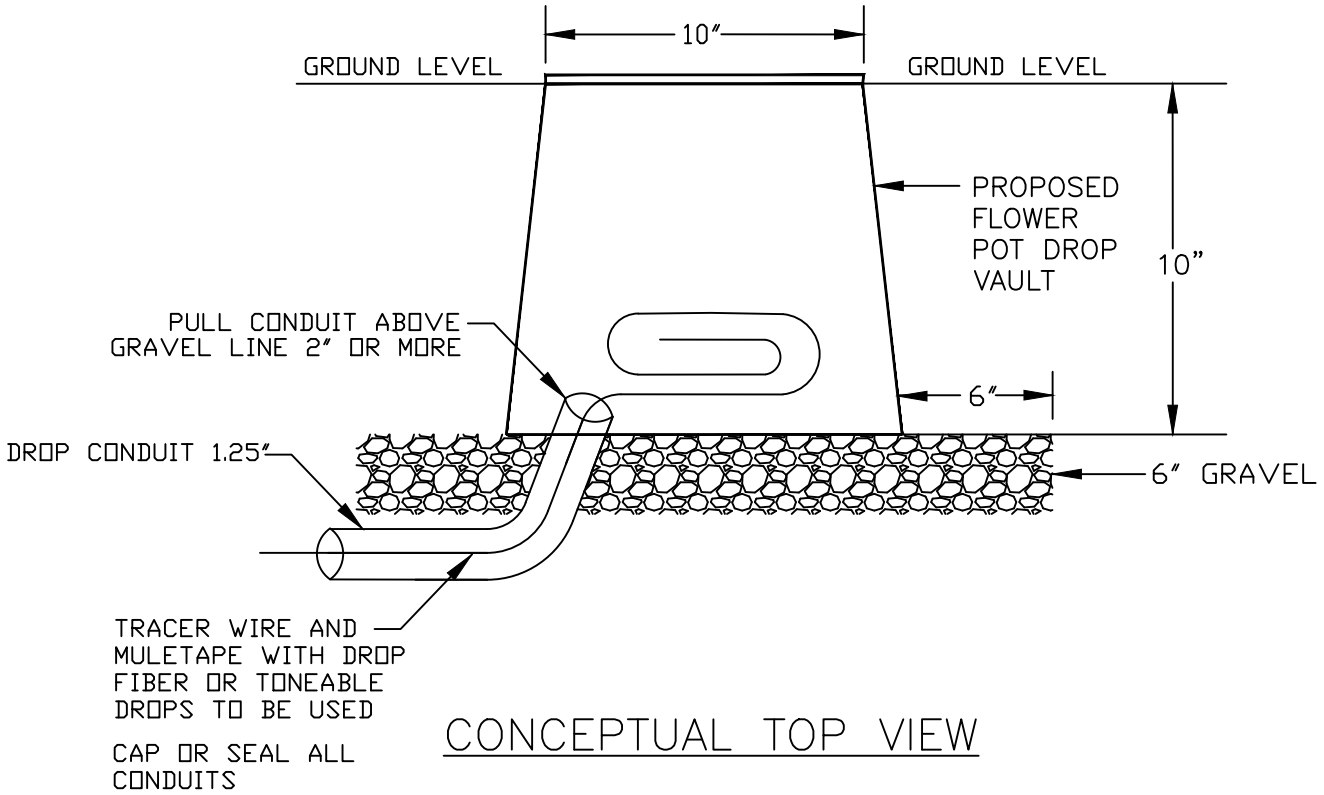

CONCEPTUAL TOP VIEW

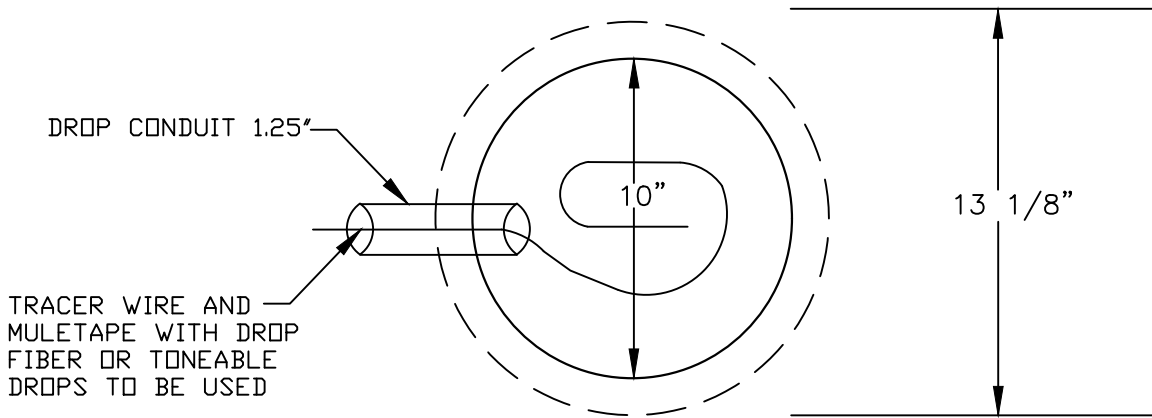

FLOWER POT

30"x48" PC UNIT, 2PC TIER 15/22
 18", 24", and 36" HEIGHT



AMERICAN POLYMER COMPANY

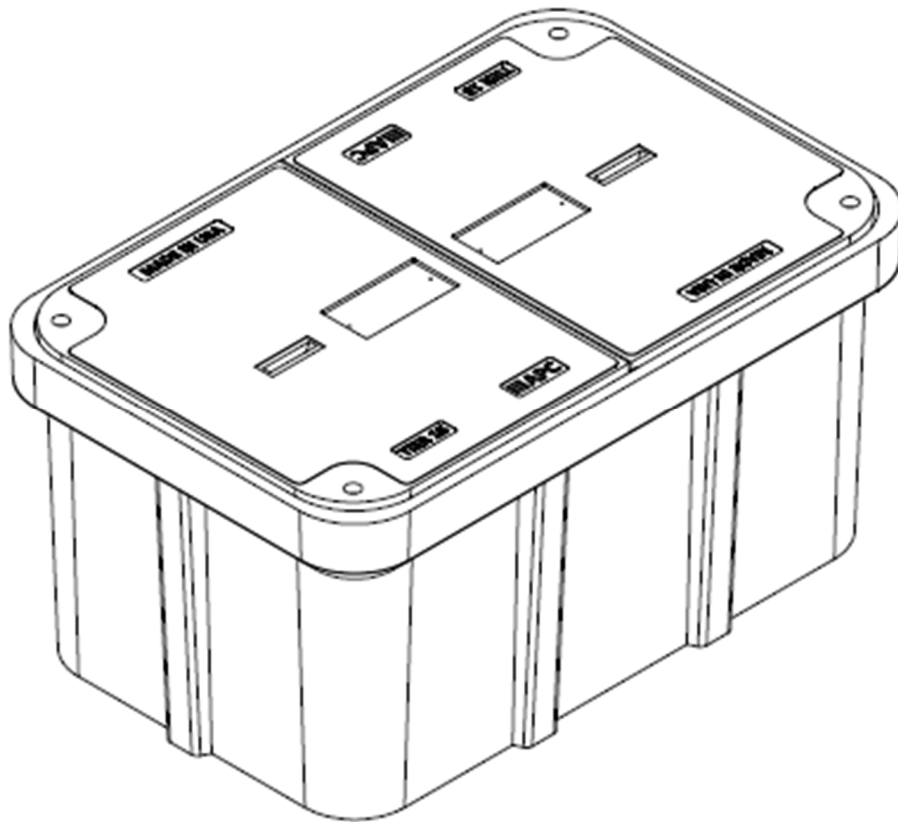

Description	Nominal Size	ANSI Tier	Part Number	Estimated Weight
PC Unit – TIER 15	30"x48"x18"	Tier 15	P304818HU15...	460 lbs.
PC Unit – TIER 22	30"x48"x18"	Tier 22	P304818HU22...	525 lbs.
PC Unit – TIER 15	30"x48"x24"	Tier 15	P304824HU15...	510 lbs.
PC Unit – TIER 22	30"x48"x24"	Tier 22	P304824HU22...	575 lbs.
PC Unit – TIER 15	30"x48"x36"	Tier 15	P304836HU15...	615 lbs.
PC Unit – TIER 22	30"x48"x36"	Tier 22	P304836HU22...	680 lbs.



30"x48" PC UNIT, 2PC TIER 15/22

18", 24", and 36" HEIGHT



AMERICAN POLYMER COMPANY

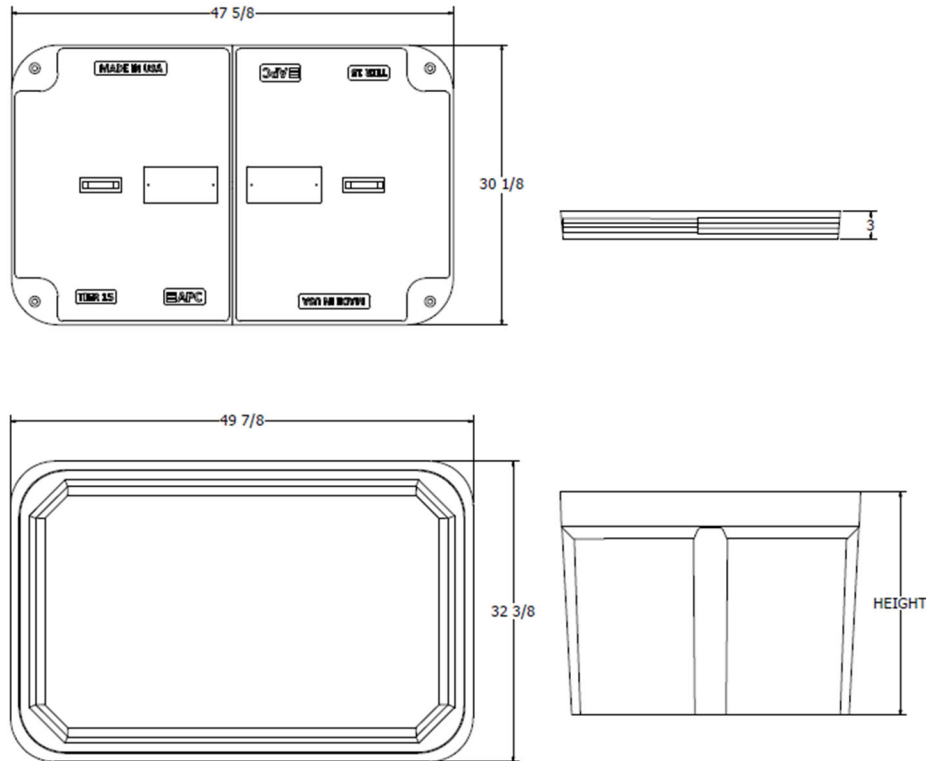

Components	Nominal Size	ANSI Tier	Part Number	Estimated Weight
Replacement Box	30"x48"x18"	Tier 22	P304818B22	185 lbs.
Replacement Box	30"x48"x24"	Tier 22	P304824B22	235 lbs.
Replacement Box	30"x48"x36"	Tier 22	P304836B22	340 lbs.
Replacement Lids - T15	30"x48" (half)	Tier 15	Various	150 lbs.
Replacement Lids - T22	30"x48" (half)	Tier 22	Various	170 lbs.

Bolt options



Machine Thread



Auger Thread



24"x36" PC UNIT, TIER 15/22
 18", 24", 30", and 36" HEIGHT



AMERICAN POLYMER COMPANY

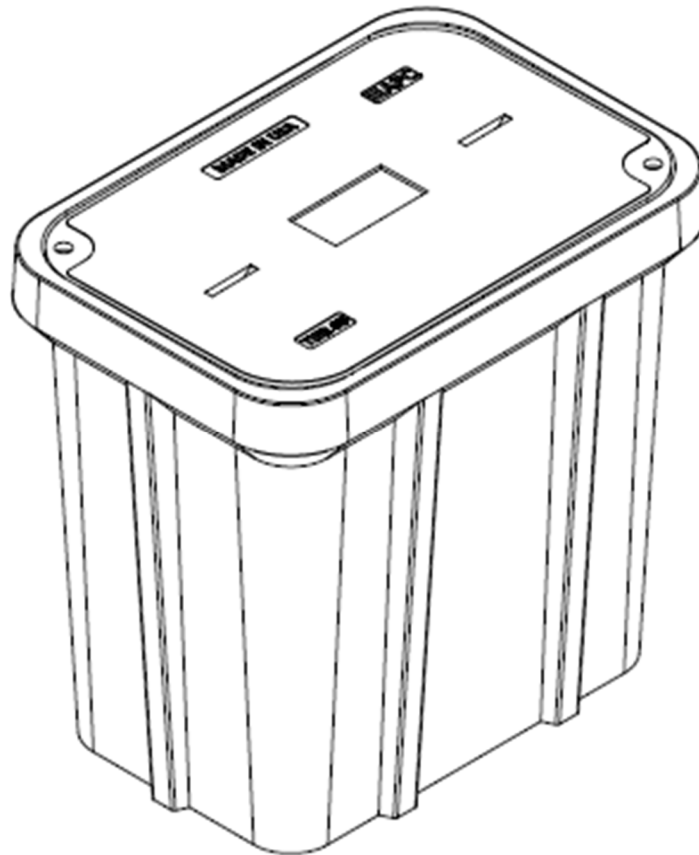

Description	Nominal Size	ANSI Tier	Part Number	Estimated Weight
PC Unit – TIER 15	24x36"x18"	Tier 15	P243618U15...	335 lbs.
PC Unit – TIER 22	24x36"x18"	Tier 22	P243618U22...	355 lbs.
PC Unit – TIER 15	24x36"x24"	Tier 15	P243624U15...	365 lbs.
PC Unit – TIER 22	24x36"x24"	Tier 22	P243624U22...	385 lbs.
PC Unit – TIER 15	24x36"x30"	Tier 15	P243630U15...	395 lbs.
PC Unit – TIER 22	24x36"x30"	Tier 22	P243630U22...	415 lbs.
PC Unit – TIER 15	24x36"x36"	Tier 15	P243636U15...	425 lbs.
PC Unit – TIER 22	24x36"x36"	Tier 22	P243636U22...	445 lbs.



24"x36" PC UNIT, TIER 15/22

18", 24", 30", and 36" HEIGHT



AMERICAN POLYMER COMPANY

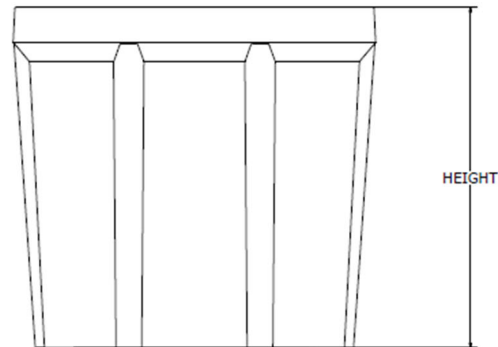
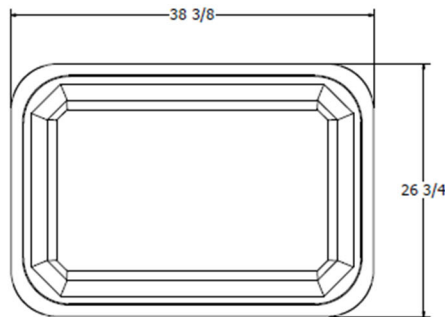
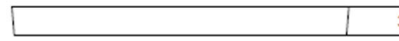
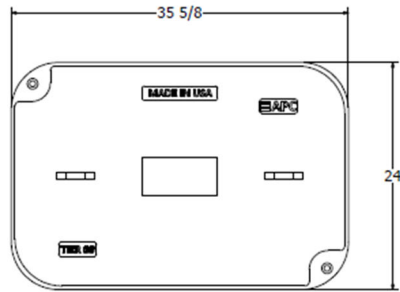

Components	Nominal Size	ANSI Tier	Part Number	Estimated Weight
Replacement Box	24"x36"x18"	Tier 22	P243618B22	165 lbs.
Replacement Box	24"x36"x24"	Tier 22	P243624B22	195 lbs.
Replacement Box	24"x36"x30"	Tier 22	P243630B22	225 lbs.
Replacement Box	24"x36"x36"	Tier 22	P243636B22	255 lbs.
Replacement Lids - T15	24"x36"	Tier 15	Various	170 lbs.
Replacement Lids - T22	24"x36"	Tier 22	Various	190 lbs.

Bolt options

Hex Head



Machine Thread



Penta Head



Auger Thread



17"x30" PC UNIT, TIER 15/22

12", 18", 24", and 30" HEIGHT



AMERICAN POLYMER COMPANY

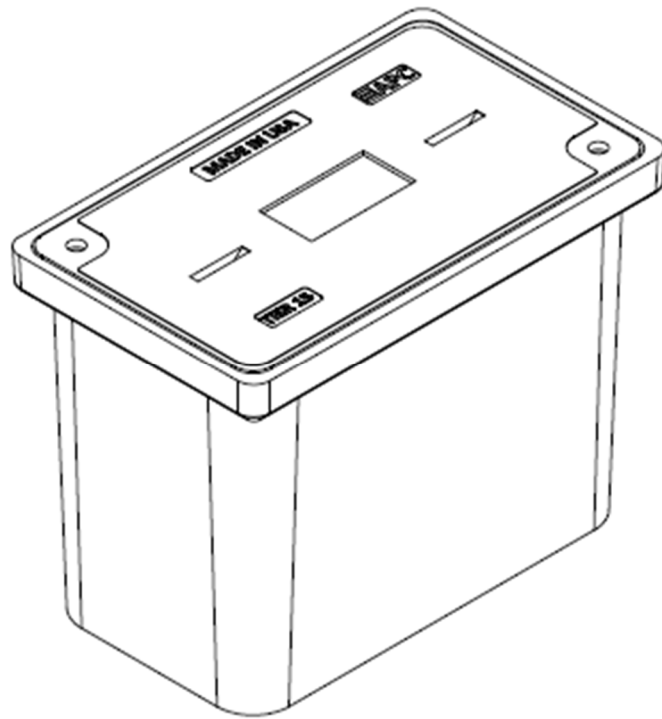

Description	Nominal Size	ANSI Tier	Part Number	Estimated Weight
PC Unit – TIER 15	17"x30"x12"	Tier 15	P173012U15...	138 lbs.
PC Unit – TIER 22	17"x30"x12"	Tier 22	P173012U22...	147 lbs.
PC Unit – TIER 15	17"x30"x18"	Tier 15	P173018U15...	172 lbs.
PC Unit – TIER 22	17"x30"x18"	Tier 22	P173018U22...	181 lbs.
PC Unit – TIER 15	17"x30"x24"	Tier 15	P173024U15...	192 lbs.
PC Unit – TIER 22	17"x30"x24"	Tier 22	P173024U22...	201 lbs.
PC Unit – TIER 15	17"x30"x30"	Tier 15	P173030U15...	217 lbs.
PC Unit – TIER 22	17"x30"x30"	Tier 22	P173030U22...	226 lbs.



17"x30" PC UNIT, TIER 15/22

12", 18", 24", and 30" HEIGHT



AMERICAN POLYMER COMPANY

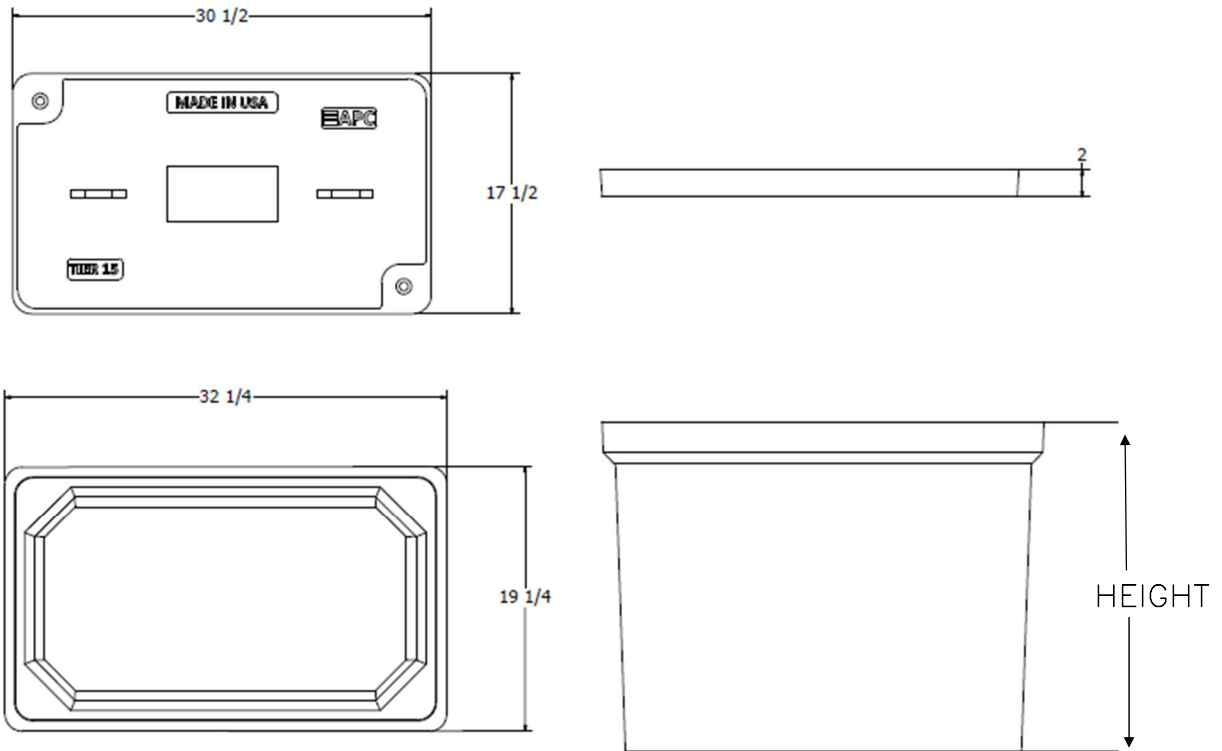

Components	Nominal Size	ANSI Tier	Part Number	Estimated Weight
Replacement Box	17"x30"x12"	Tier 22	P173012B22	66 lbs.
Replacement Box	17"x30"x18"	Tier 22	P173018B22	100 lbs.
Replacement Box	17"x30"x24"	Tier 22	P173024B22	120 lbs.
Replacement Box	17"x30"x30"	Tier 22	P173030B22	145 lbs.
Replacement Lids – T15	17"x30"	Tier 15	Various	72 lbs.
Replacement Lids – T22	17"x30"	Tier 22	Various	81 lbs.

Bolt options



Machine Thread



Auger Thread



33"x60" PC UNIT, 2PC TIER 15/22
36" HEIGHT



AMERICAN POLYMER COMPANY

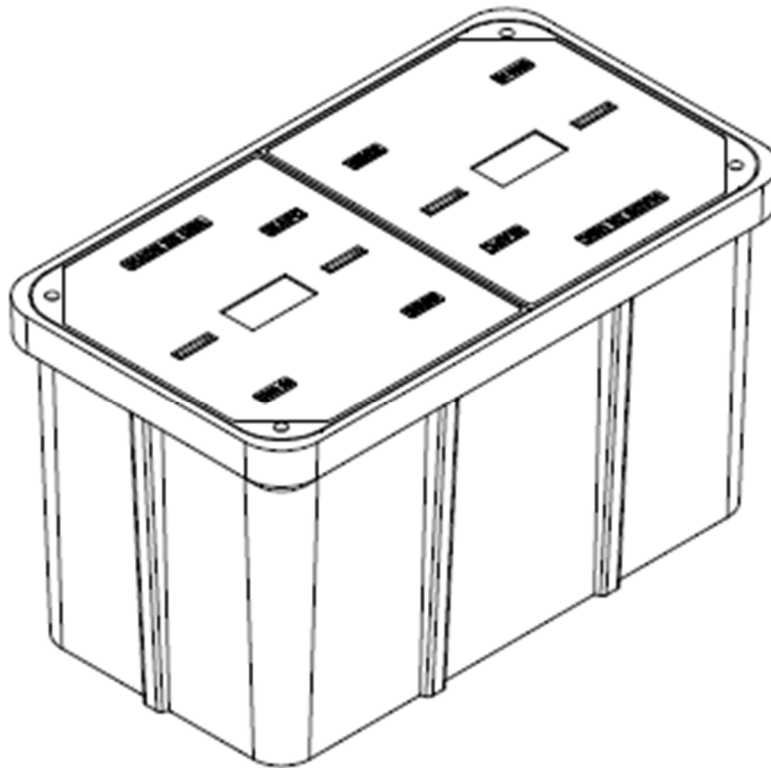

Description	Nominal Size	ANSI Tier	Part Number	Estimated Weight
PC Unit - TIER 15	33"x60"x36"	Tier 15	P336036U15...	930 lbs.
PC Unit - TIER 22	33"x60"x36"	Tier 22	P336036U22...	1030 lbs.



33"x60" PC UNIT, 2PC TIER 15/22

36" HEIGHT



AMERICAN POLYMER COMPANY

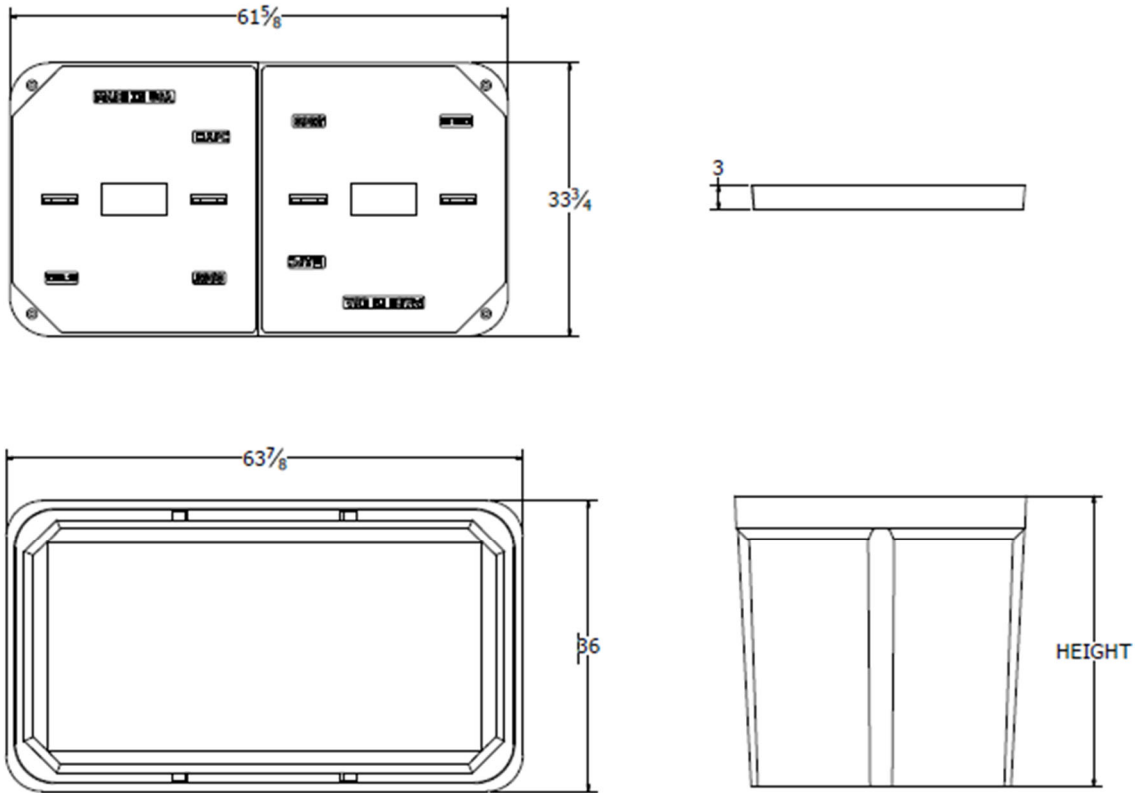

Components	Nominal Size	ANSI Tier	Part Number	Estimated Weight
Replacement Box	33"x60"x36"	Tier 22	P336036B22	530 lbs.
Replacement Lids - T15	33"x60" (half)	Tier 15	Various	200 lbs.
Replacement Lids - T22	33"x60" (half)	Tier 22	Various	250 lbs.

Bolt options

Hex Head



Machine Thread



Penta Head



Auger Thread



Spacing Charts Based on MUTCD			Must be Approved by an Engineer				
Speed (MPH) Prior To Road Work	SIGN SPACING, FT.		BUFFER SPACE, FT.	TAPER LENGTH, FT.	CHANNELIZING SPACING, FT.		
	Non-Divided Highways	Divided Highways	Length	Shoulder (10 ft. Width)	Lane (12 ft. Width)	Through Taper	Through Buffer/Work Area
0-35	200	200	250	70	245	35	50
40-45	350	500	360	150	540	40	80
50-55	500	1000	495	185	660	50	100
60-70	SA-1000, SB-1500, SC-2640 Urban Low Speed - 100 FT		730	235	840	60	120

APPROVED/ACCEPTED BY:
ENGINEER, OWNER, or PRIME CONTRACTOR
 Check for Notice to Proceed.
BLC01a-F14 - S Woodcrest Ln - TCP

Signature: _____

Company: _____

Road Runner Safety Services, Inc.

Date: 9/29/2022 Project: BLC01a-F14 - S Woodcrest Ln - TCP :
Traffic Control Suggestion For: AEG :
By: Road Runner Safety Services, Inc. : Nathan

Comments:
Drawing not to scale. Traffic control plan must be approved by an engineer. This is a suggestion only. Road Runners Safety Services, Inc. has no liability for this suggested traffic control plan. Actual placement and spacing of all traffic control devices will depend on field conditions and must conform to MUTCD standards.

- Legend**
- ADA Barricade
 - Channelizer
 - Conduit
 - Flagger (Person)
 - Sign
 - Vault
 - Work Area

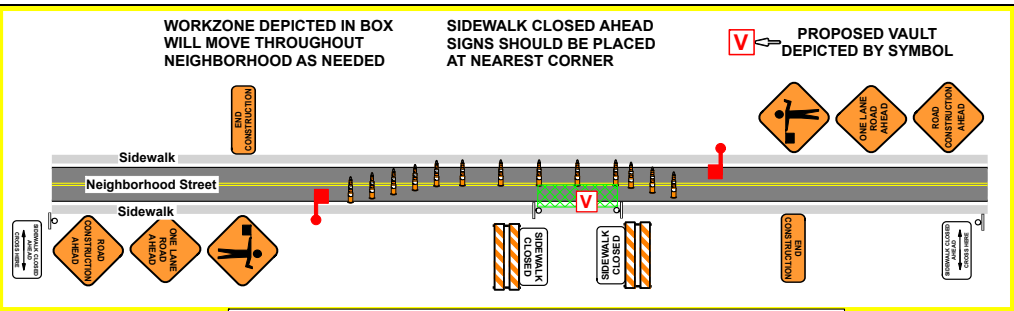

Flagger setup shown in box above will move thru residential streets. See additional pages for work on College Mall Rd and E Moores Pike.

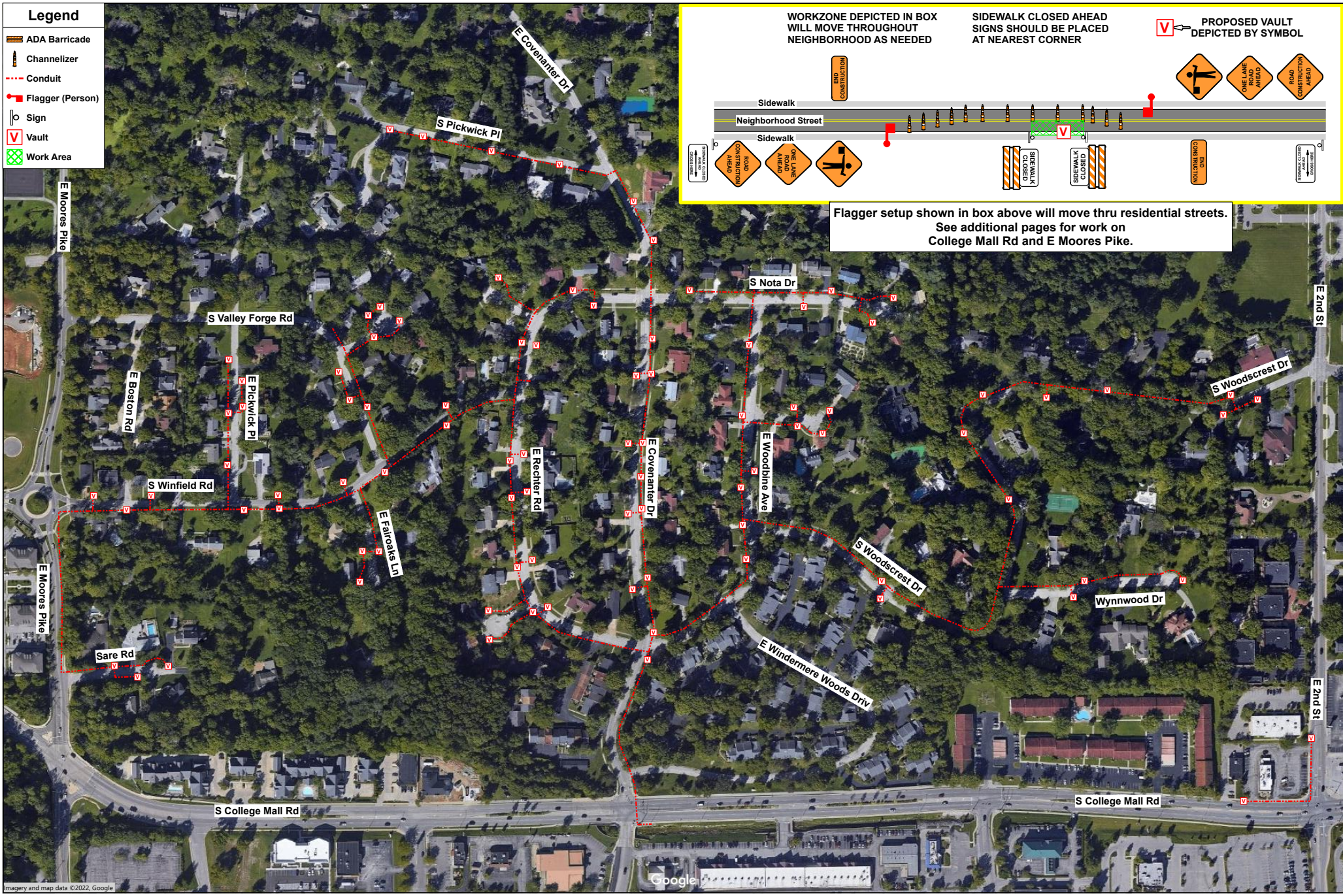

Spacing Charts Based on MUTCD		Must be Approved by an Engineer					
Speed (MPH) Prior To Road Work	SIGN SPACING, FT.		BUFFER SPACE, FT.	TAPER LENGTH, FT.	CHANNELIZING SPACING, FT.		
	Non-Divided Highways	Divided Highways	Length	Shoulder (10 ft. Wide)	Lane (12 ft. Wide)	Through Taper	Through Buffer/Work Area
0-35	200	200	250	70	245	35	50
40-45	350	500	360	150	540	40	80
50-55	500	1000	495	185	660	50	100
60-70	SA-1000, SB-1500, SC-2640		730	235	840	60	120
Urban Low Speed - 100 FT							

APPROVED/ACCEPTED BY:
ENGINEER, OWNER, or PRIME CONTRACTOR
 Check for Notice to Proceed.
BLC01a-F14 - S Woodcrest Ln - TCP

Signature: _____

Company: _____

Date: 9/29/2022 Project: BLC01a-F14 - S Woodcrest Ln - TCP :
: Traffic Control Suggestion For: AEG :
By: Road Runner Safety Services, Inc. : Nathan

Comments:
Drawing not to scale. Traffic control plan must be approved by an engineer. This is a suggestion only. Road Runners Safety Services, Inc. has no liability for this suggested traffic control plan. Actual placement and spacing of all traffic control devices will depend on field conditions and must conform to MUTCD standards.

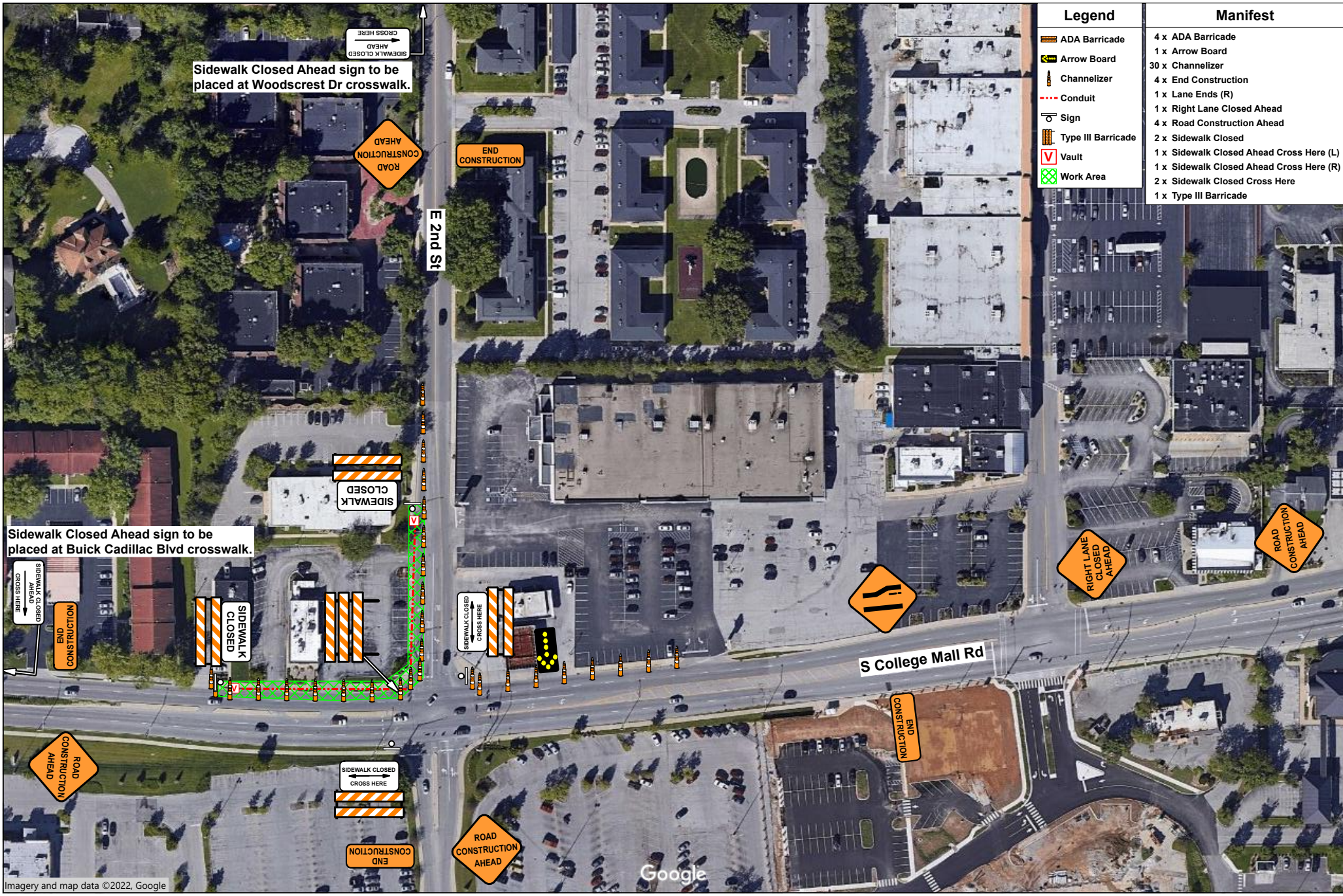

Spacing Charts Based on MUTCD			Must be Approved by an Engineer				
Speed (MPH) Prior To Road Work	SIGN SPACING, FT.		BUFFER SPACE, FT.	TAPER LENGTH, FT.	CHANNELIZING SPACING, FT.		
	Non-Divided Highways	Divided Highways	Length	Shoulder (10 ft. Width)	Lane (12 ft. Width)	Through Taper	Through Buffer/Work Area
0-35	200	200	250	70	245	35	50
40-45	350	500	360	150	540	40	80
50-55	500	1000	495	185	660	50	100
60-70	SA-1000, SB-1500, SC-2640		730	235	840	60	120
Urban Low Speed - 100 FT							

APPROVED/ACCEPTED BY:
ENGINEER, OWNER, or PRIME CONTRACTOR
 Check for Notice to Proceed.
BLC01a-F14 - S Woodcrest Ln - TCP

Signature: _____

Company: _____

Road Runner
Safety Services, Inc.

Date: 9/29/2022 Project: BLC01a-F14 - S Woodcrest Ln - TCP :
: Traffic Control Suggestion For: AEG :
By: Road Runner Safety Services, Inc. : Nathan

Comments:
Drawing not to scale. Traffic control plan must be approved by an engineer. This is a suggestion only. Road Runners Safety Services, Inc. has no liability for this suggested traffic control plan. Actual placement and spacing of all traffic control devices will depend on field conditions and must conform to MUTCD standards.

- Manifest**
- 4 x ADA Barricade
 - 23 x Channelizer
 - 6 x End Construction
 - 5 x Flagger
 - 1 x Keep Right
 - 4 x One Lane Road Ahead
 - 7 x Road Construction Ahead
 - 3 x Sidewalk Closed
 - 1 x Sidewalk Closed Ahead
 - 1 x Sidewalk Closed Ahead Cross Here (L)
 - 1 x Sidewalk Closed Ahead Cross Here (R)
 - 1 x Sidewalk Closed Cross Here

- Legend**
- ADA Barricade
 - Channelizer
 - Flagger (Person)
 - Sign
 - Work Area

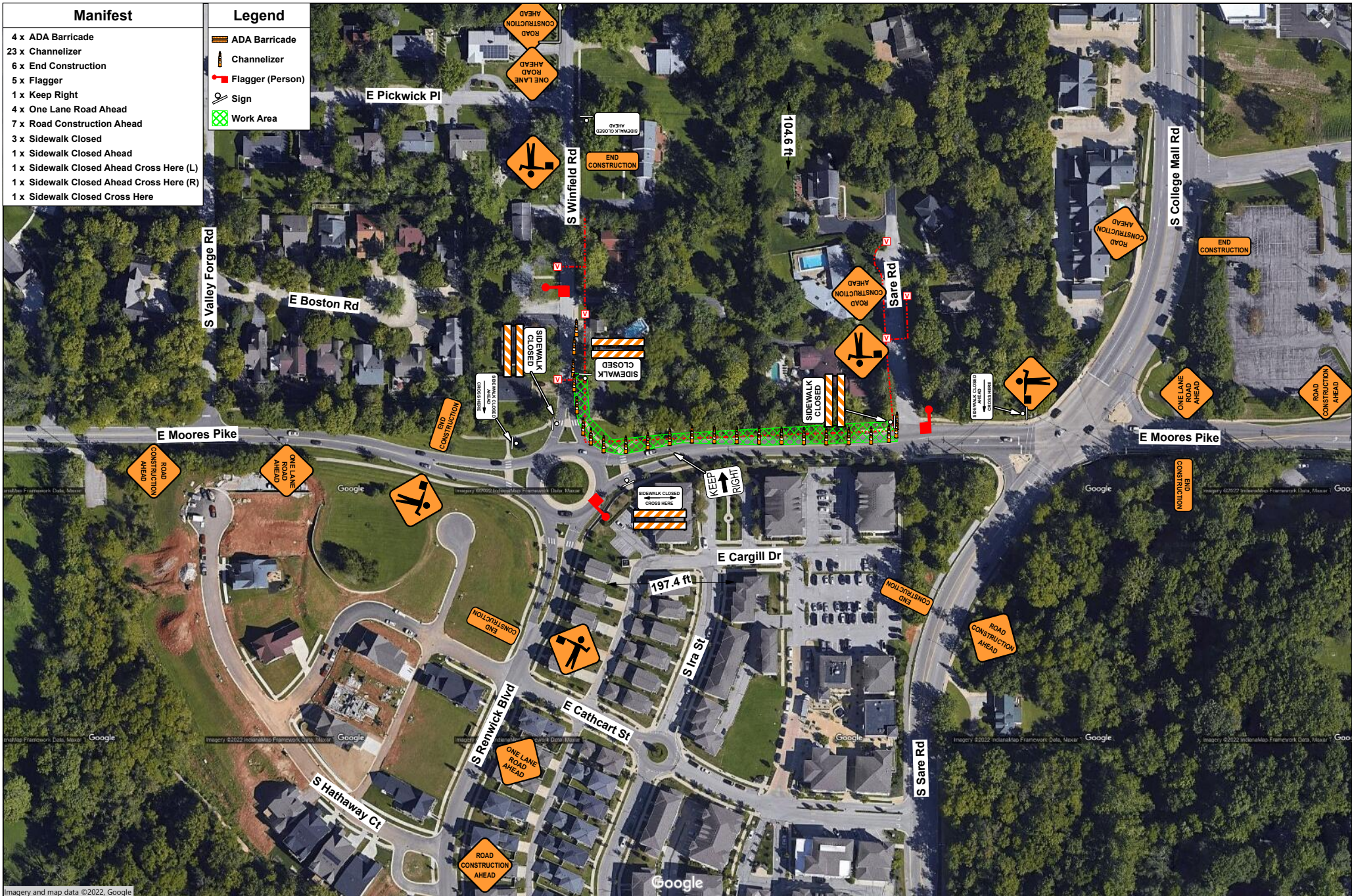



CITY OF BLOOMINGTON RIGHT-OF-WAY USE PERMIT APPLICATION

401 N Morton Street, Suite 130
P.O. Box 100
Bloomington, IN 47402

Phone: (812) 349-3913
Fax: (812) 349-3520
Email:
engineering@bloomington.in.gov

ROW EXCAVATION ROW USE

ADDRESS OF ROW ACTIVITY: _____

A. APPLICANT/AGENT INFORMATION: APPLICANT NAME: _____ E-MAIL: _____ COMPANY: _____ ADDRESS: _____ CITY, STATE, ZIP: _____ 24-HR EMERGENCY CONTACT NAME: _____ 24-HR CONTACT PHONE #: _____ INSURANCE #*: 883724951 COMPANY: ACORD BOND#*: _____ COMPANY: _____ <small>* INSURANCE & BOND MUST BE ON FILE WITH THE CITY BEFORE PERMIT WILL BE ISSUED</small>	D. TRAFFIC CONTROL DEVICES*: <input type="checkbox"/> CONES <input type="checkbox"/> ARROWBOARD <input type="checkbox"/> LIGHTED BARRELS <input type="checkbox"/> TYPE 3 BARRICADES <input type="checkbox"/> FLAGGERS <input type="checkbox"/> BPD OFFICER <small>*PROVIDING MUTCD COMPLIANT TEMPORARY TRAFFIC CONTROL DEVICES AND MAINTENANCE OF TRAFFIC (MOT) PLAN IS YOUR RESPONSIBILITY AND REQUIRED See page 3 for additional MOT resources; the graph paper can be used for your MOT site plan if needed or you can submit a separate sheet</small>
SUBCONTRACTOR INFORMATION (LIST ALL COMPANIES WORKING UNDER PRIMARY CONTRACTOR PERMIT) COMPANY NAME: _____	E. METERED PARKING SPACES NEEDED: <input type="checkbox"/> Y <input type="checkbox"/> N <small>IT IS THE RESPONSIBILITY OF THE APPLICANT TO RESERVE PARKING METER(S) APPLICATION LOCATED: https://bloomington.in.gov/transportation/parking/moving OR CONTACT PARKING SERVICES WITH QUESTIONS AT (812)349-3436</small>
B. WORK DESCRIPTION: <input type="checkbox"/> POD/DUMPSTER <input type="checkbox"/> CRANE <input type="checkbox"/> SCAFFOLDING <input type="checkbox"/> CONSTRUCTION USE* (EXPLAIN): _____ <small>*EXCAVATION, LONG TERM USE FOR STORAGE OF MATERIAL/EQUIPMENT/WALKAROUND</small>	F. IS THIS A <input type="checkbox"/> CBU* <input type="checkbox"/> COUNTY* <input type="checkbox"/> IU* <input type="checkbox"/> NP* PROJECT? PROJECT NAME: _____ PROJECT #: _____ PROJECT MGR.: _____ PROJECT MGR. #: _____ <small>*CBU = CITY OF BLOOMINGTON UTILITIES *COUNTY = MONROE COUNTY *IU= INDIANA UNIVERSITY *NP= NOT-FOR-PROFIT AGENCY</small>
C. RIGHT OF WAY TO BE USED/CLOSED: STREET NAME 1: _____ 1ST INTERSECTING STREET NAME: _____ 2ND INTERSECTING STREET NAME: _____ <input type="checkbox"/> ROAD CLOSURE <input type="checkbox"/> LANE CLOSURE 1 <input type="checkbox"/> 2 <input type="checkbox"/> 3 <input type="checkbox"/> <input type="checkbox"/> SIDEWALK* <input type="checkbox"/> BIKE LANE <input type="checkbox"/> OTHER TRANSIT STOP? <input type="checkbox"/> Y <input type="checkbox"/> N PARKING LANE(S)** <input type="checkbox"/> Y <input type="checkbox"/> N <small>**NON-METERED</small> START DATE: _____ END DATE: _____ # OF DAYS*: _____ STREET NAME 2: _____ 1ST INTERSECTING STREET NAME: _____ 2ND INTERSECTING STREET NAME: _____ <input type="checkbox"/> ROAD CLOSURE <input type="checkbox"/> LANE CLOSURE 1 <input type="checkbox"/> 2 <input type="checkbox"/> 3 <input type="checkbox"/> <input type="checkbox"/> SIDEWALK* <input type="checkbox"/> BIKE LANE <input type="checkbox"/> OTHER TRANSIT STOP? <input type="checkbox"/> Y <input type="checkbox"/> N PARKING LANE(S)** <input type="checkbox"/> Y <input type="checkbox"/> N <small>**NON-METERED</small> START DATE: _____ END DATE: _____ # OF DAYS*: _____ <small>*SIDEWALK CLOSURES FOR A PERIOD OR PERIODS TOTALING 24HRS OR MORE SHALL INSTALL A WALKAROUND UNLESS OTHERWISE APPROVED DURING REVIEW</small>	G. EXCAVATIONS: SQ FT OF PAVEMENT* EXCAVATIONS : _____ <small>*PAVEMENT INCLUDES: IN OR UNDER CONCRETE, OR ASPHALT INCLUDING CURBS</small> SQ FT OF NON-PAVEMENT* EXCAVATIONS: _____ <small>*DIRT, GRASS, GRAVEL, LANDSCAPE AREA OR OTHER UNPAVED SURFACE</small> LINEAL FT OF BORE*: _____ <small>*BORE PITS SHALL BE CALCULATED AS SQ FT EXCAVATIONS</small> # OF POLE INSTALLATIONS/REMOVAL: _____ SQ FT OF SIDEWALK RECONSTRUCTION*: _____ <small>*CONCRETE OR ASPHALT SIDEWALK/PATH BEING IMPROVED/REPLACED</small> SQ FT OF SIDEWALK NEW CONSTRUCTION*: _____ <small>*CONCRETE OR ASPHALT SIDEWALK/PATH THAT IS NEW INFRASTRUCTURE</small> #RESIDENTIAL DRIVEWAY INSTALLATION: _____
STANDARD CLOSURE HOURS MON-FRI*: 9:00 AM - 3:00 PM & 6:00 PM - 9:00 PM STANDARD CLOSURE HOURS <input type="checkbox"/> *NON-STANDARD CLOSURE HOURS <input type="checkbox"/> REQUESTED CLOSURE HOURS: _____ AM - _____ PM <small>*non-standard hours may not be allowed near schools, on arterials, or other circumstances and are subject to approval during the permitting process BMC 14.09.040 allows work from 6 AM to 10 PM without violating the noise ordinance (7AM to 9PM for pneumatic hammers)</small>	 TO SUBMIT A LOCATE REQUEST 24 HRS A DAY, 7 DAYS A WEEK CALL 811 OR 800-382-5544 CALL 2 WORKING DAYS BEFORE YOU DIG. ITS THE LAW.
H. INDEMNIFICATION AGREEMENT: The petitioner/applicant hereby agrees to hold harmless, defend and to indemnify the City of Bloomington from or against all claims, action, damages and expenses, including but not limited to reasonable attorney's fees or any alleged injury and/or death to any person or damage to any property arising, or alleged to have arisen out of any act of commission or omission on the part of the petitioner/applicant, his/her heirs, successors, or assigns regardless of whether such acts are the direct or indirect result of the public right-of-way use pursuant to this permit grant. I AFFIRM, UNDER THE PENALTIES FOR PERJURY, THAT THE FOREGOING REPRESENTATIONS ARE TRUE. PRINT NAME: _____ SIGNATURE: <u>Bret Simans</u> DATE: _____	

For Administration Use Only (applicable to CLOSURE approval)

Approved By: _____ BPW City Engineer Director Date: _____

Staff Representative: _____ Phone#: _____ Date: _____



Board of Public Works Staff Report

Project/Event:	Request from Strauser Construction for full street closure on E 19 th St west of N Dunn St
Staff Representative:	Paul Kehrberg
Petitioner/Representative:	Ryan Strauser, Strauser Construction Co., Inc.
Date:	October 11, 2022

Report: Strauser Construction is the construction manager for the new mixed use development on E 19th St between N Lincoln St and N Dunn St. They are requesting a full street closure on E 19th St from N Grant St to N Dunn St. City staff and representatives from Strauser Construction met on site to discuss various options. Due to the newly constructed sidewalk to the west and upcoming future development to the south, a full street closure and pedestrian detour is the best solution. This will minimize conflicts and route pedestrians along sidewalks to an existing crosswalk on N Dunn St near the IU bus stop.

Staff has reviewed the maintenance of traffic plan. The closure will be in place from October 10, 2022 to August 8, 2023.

October 3, 2022

City of Bloomington - Board of Public Works

401 N. Morton Street
Bloomington, IN 47404

RE: 19th & Dunn Mixed-Use Project
307-421 E. 19th Street
Bloomington, Indiana
Use of Right of Way / Closures

Dear Board Members:

Strauser Construction Co., Inc. is the construction manager for the 19th & Dunn Mixed-Use project located on the north side of 19th Street. The project consists of a new 6-level building containing residential apartments, parking, amenity space and retail.

As part of the project, Strauser Construction Co., Inc. is requesting the use of the right of way to complete work associated with the project. Use of the right of way includes a street/lane closures and temporary fencing request.

The first phase of right of way use will include a full closure of 19th Street between Dunn Street and Grant Street as well as fencing install locations within the right of way. After review with City Engineering, we are proposing this solution for street closure based on the current conditions of no sidewalk along 19th Street and the required scope of work we are performing in the right of way for this area, including replacement of the City water main in 19th Street. During this phase of the MOT, pedestrians will be crossed to Grant Street and then to 18th Street to provide a sidewalk towards the IU transit stop. This option reduces time pedestrians are utilizing a street that does not have a sidewalk.

The request for this phase of the MOT is 10/10/22 through 8/8/23. During this time, we believe this will provide the best route for pedestrians and vehicular traffic while the project makes public infrastructure improvements including installation of a new upgraded water main and new sidewalks within the right of way.

During the course of this project Strauser Construction Co., Inc. will work with the City of Bloomington Engineering staff and other departments to minimize disruptions caused by the project. Based on this and the attached MOT information, Strauser Construction Co., Inc. request that the Board of Public Works approves the use of the right of way during the time periods stated above.

Sincerely,





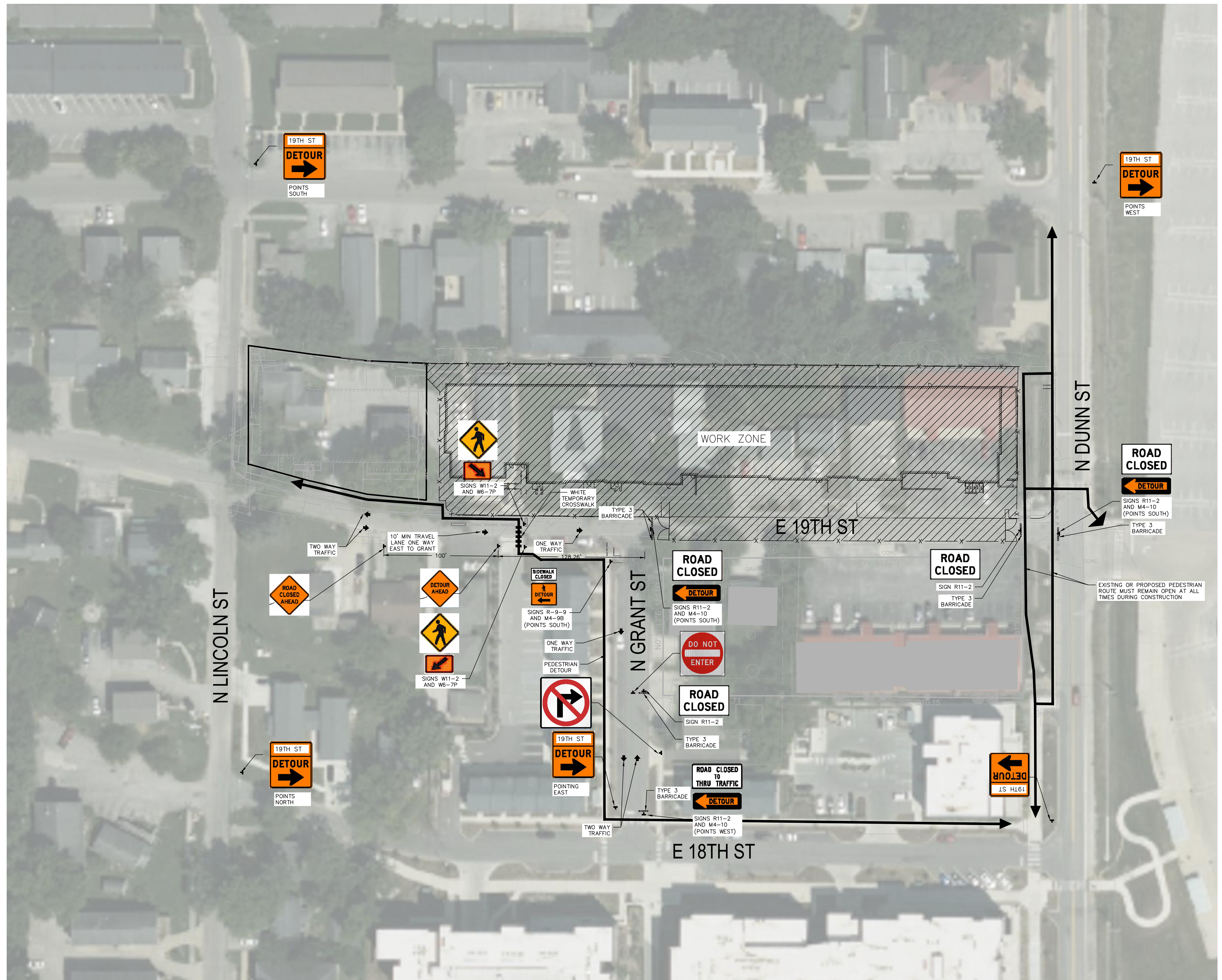

Ryan M. Strauser
RA, AIA, LEED AP

Strauser Construction Co., Inc.
453 S. Clarizz Blvd.
Bloomington, IN 47401

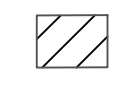
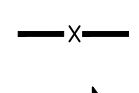

E 19TH ST MAINTENANCE OF TRAFFIC PLAN - PHASE 1

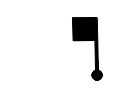
MAINTENANCE OF TRAFFIC LEGEND

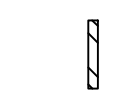
-  WORK ZONE
-  CONSTRUCTION FENCE
-  PEDESTRIAN ROUTE
-  CHANNELIZING DEVICE (DRUM)
-  FLAGGER
-  CONSTRUCTION SIGN
-  TYPE 3 BARRICADE

MAINTENANCE OF TRAFFIC NOTES

1. CONTRACTOR IS RESPONSIBLE FOR MAINTENANCE OF TRAFFIC. ALL MAINTENANCE OF TRAFFIC MUST BE IN ACCORDANCE WITH THE LATEST REVISION OF THE INDIANA MANUAL OF UNIFORM TRAFFIC CONTROL DEVICES (MUTCD) AND SHALL MEET CITY OF BLOOMINGTON MUNICIPAL CODE.
2. CONTRACTOR IS TO MAINTAIN ACCESS TO ALL DRIVEWAYS AT ALL TIMES. CONTRACTOR IS TO WORK CLOSELY WITH LOCAL RESIDENTS SO THEY ARE AWARE OF HOW TO ACCESS THEIR PROPERTIES DURING CONSTRUCTION.

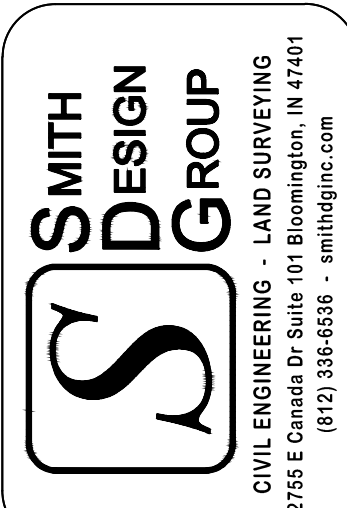

XX/XX/20XX

**19TH & DUNN ST
MIXED USE BUILDING
MAINTENANCE OF TRAFFIC PLANS
BLOOMINGTON, INDIANA**

REVISIONS	BY	DATE

DESIGNED	DRAWN	CHECKED	DATE
KCK	KCK	KCK	

JOB NUMBER
6380
SHEET
M300
DATE
10/04/2022
E 19TH ST
MAINTENANCE OF
TRAFFIC PLAN

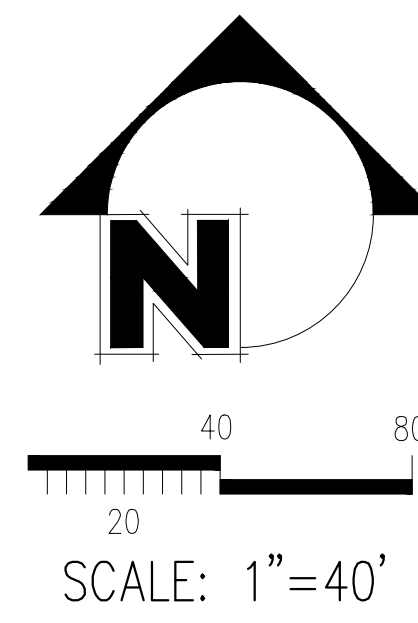



CITY OF BLOOMINGTON

RIGHT-OF-WAY USE PERMIT APPLICATION

401 N Morton Street, Suite 130
P.O. Box 100
Bloomington, IN 47402

Phone: (812) 349-3913
Fax: (812) 349-3520
Email: engineering@bloomington.in.gov

ROW EXCAVATION ROW USE

ADDRESS OF ROW ACTIVITY: 307-421 E. 19th Street

<p>A. APPLICANT/AGENT INFORMATION:</p> <p>APPLICANT NAME: <u>Ryan M. Strauser</u></p> <p>E-MAIL: <u>rmstrauser@strausercci.com</u></p> <p>COMPANY: <u>Strauser Construction Co., Inc.</u></p> <p>ADDRESS: <u>453 S. Clarizz Blvd.</u></p> <p>CITY, STATE, ZIP: <u>Bloomington, IN 47401</u></p> <p>24-HR EMERGENCY CONTACT NAME: <u>Ryan Strauser</u></p> <p>24-HR CONTACT PHONE #: <u>812-360-1503</u></p> <p>INSURANCE #*: _____ COMPANY: <u>Hylant-Selective</u></p> <p>BOND #*: _____ COMPANY: <u>Hylant-Nationwide</u></p> <p><small>* INSURANCE & BOND MUST BE ON FILE WITH THE CITY BEFORE PERMIT WILL BE ISSUED</small></p> <p style="text-align: center;">**SUBCONTRACTOR INFORMATION**</p> <p style="text-align: center;"><small>(LIST ALL COMPANIES WORKING UNDER PRIMARY CONTRACTOR PERMIT)</small></p> <p>COMPANY NAME: <u>Strauser Construction Co., Inc.</u></p> <p>B. WORK DESCRIPTION:</p> <p><input type="checkbox"/> POD/DUMPSTER <input type="checkbox"/> CRANE <input type="checkbox"/> SCAFFOLDING <input checked="" type="checkbox"/> CONSTRUCTION USE*</p> <p>(EXPLAIN): <u>Long Term Construction</u></p> <p><small>*EXCAVATION, LONG TERM USE FOR STORAGE OF MATERIAL/EQUIPMENT/WALKAROUND</small></p> <p>C. RIGHT OF WAY TO BE USED/CLOSED:</p> <p>STREET NAME 1: <u>19th Street (Between Dunn St. & Grant St.)</u></p> <p>1ST INTERSECTING STREET NAME: _____</p> <p>2ND INTERSECTING STREET NAME: _____</p> <p><input checked="" type="checkbox"/> ROAD CLOSURE <input checked="" type="checkbox"/> LANE CLOSURE 1 <input type="checkbox"/> 2 <input type="checkbox"/> 3 <input type="checkbox"/></p> <p><input type="checkbox"/> SIDEWALK* <input type="checkbox"/> BIKE LANE <input type="checkbox"/> OTHER</p> <p>TRANSIT STOP? <input type="checkbox"/> Y <input checked="" type="checkbox"/> N PARKING LANE(S)** <input type="checkbox"/> Y <input checked="" type="checkbox"/> N <small>**NON-METERED</small></p> <p>START DATE: <u>10/10/22</u> END DATE: <u>8/8/23</u> # OF DAYS*: _____</p> <p>**Continuous street closure with pedestrian alternate route</p> <p>STREET NAME 2: _____</p> <p>1ST INTERSECTING STREET NAME: _____</p> <p>2ND INTERSECTING STREET NAME: _____</p> <p><input type="checkbox"/> ROAD CLOSURE <input type="checkbox"/> LANE CLOSURE 1 <input type="checkbox"/> 2 <input type="checkbox"/> 3 <input type="checkbox"/></p> <p><input type="checkbox"/> SIDEWALK* <input type="checkbox"/> BIKE LANE <input type="checkbox"/> OTHER</p> <p>TRANSIT STOP? <input type="checkbox"/> Y <input type="checkbox"/> N PARKING LANE(S)** <input type="checkbox"/> Y <input type="checkbox"/> N <small>**NON-METERED</small></p> <p>START DATE: _____ END DATE: _____ # OF DAYS*: _____</p> <p><small>*SIDEWALK CLOSURES FOR A PERIOD OR PERIODS TOTALING 24HRS OR MORE SHALL INSTALL A WALKAROUND UNLESS OTHERWISE APPROVED DURING REVIEW</small></p> <p>STANDARD CLOSURE HOURS MON-FRI*: 9:00 AM - 3:00 PM & 6:00 PM - 9:00 PM</p> <p>STANDARD CLOSURE HOURS <input type="checkbox"/> *NON-STANDARD CLOSURE HOURS <input type="checkbox"/></p> <p>REQUESTED CLOSURE HOURS: <u>24 hours</u>AM - _____ PM</p> <p><small>*non-standard hours may not be allowed near schools, on arterials, or other circumstances and are subject to approval during the permitting process</small></p> <p><small>BMC 14.09.040 allows work from 6 AM to 10 PM without violating the noise ordinance (7AM to 9PM for pneumatic hammers)</small></p>	<p>D. TRAFFIC CONTROL DEVICES*:</p> <p><input checked="" type="checkbox"/> CONES <input type="checkbox"/> ARROWBOARD</p> <p><input type="checkbox"/> LIGHTED BARRELS <input checked="" type="checkbox"/> TYPE 3 BARRICADES</p> <p><input type="checkbox"/> FLAGGERS <input type="checkbox"/> BPD OFFICER</p> <p><small>*PROVIDING MUTCD COMPLIANT TEMPORARY TRAFFIC CONTROL DEVICES AND MAINTENANCE OF TRAFFIC (MOT) PLAN IS YOUR RESPONSIBILITY AND REQUIRED. See page 3 for additional MOT resources; the graph paper can be used for your MOT site plan if needed or you can submit a separate sheet</small></p> <p>E. METERED PARKING SPACES NEEDED: <input type="checkbox"/> Y <input checked="" type="checkbox"/> N</p> <p><small>IT IS THE RESPONSIBILITY OF THE APPLICANT TO RESERVE PARKING METER(S) APPLICATION LOCATED: https://bloomington.in.gov/transportation/parking/moving OR CONTACT PARKING SERVICES WITH QUESTIONS AT (812)349-3436</small></p> <p>F. IS THIS A <input type="checkbox"/> CBU* <input type="checkbox"/> COUNTY* <input type="checkbox"/> IU* <input type="checkbox"/> NP* PROJECT?</p> <p>PROJECT NAME: _____</p> <p>PROJECT #: _____</p> <p>PROJECT MGR.: _____</p> <p>PROJECT MGR. #: _____</p> <p><small>*CBU = CITY OF BLOOMINGTON UTILITIES *COUNTY = MONROE COUNTY *IU = INDIANA UNIVERSITY *NP = NOT-FOR-PROFIT AGENCY</small></p> <p>G. EXCAVATIONS:</p> <p>SQ FT OF PAVEMENT* EXCAVATIONS : <u>Separate Request</u></p> <p><small>*PAVEMENT INCLUDES: IN OR UNDER CONCRETE, OR ASPHALT INCLUDING CURBS</small></p> <p>SQ FT OF NON-PAVEMENT* EXCAVATIONS: <u>Separate Request</u></p> <p><small>*DIRT, GRASS, GRAVEL, LANDSCAPE AREA OR OTHER UNPAVED SURFACE</small></p> <p>LINEAL FT OF BORE*: <u>NA</u></p> <p><small>*BORE PITS SHALL BE CALCULATED AS SQ FT EXCAVATIONS</small></p> <p># OF POLE INSTALLATIONS/REMOVAL: <u>NA</u></p> <p>SQ FT OF SIDEWALK RECONSTRUCTION*: <u>Separate Request</u></p> <p><small>*CONCRETE OR ASPHALT SIDEWALK/PATH BEING IMPROVED/REPLACED</small></p> <p>SQ FT OF SIDEWALK NEW CONSTRUCTION*: <u>Separate Request</u></p> <p><small>*CONCRETE OR ASPHALT SIDEWALK/PATH THAT IS NEW INFRASTRUCTURE</small></p> <p># RESIDENTIAL DRIVEWAY INSTALLATION: <u>NA</u></p> <div style="text-align: center;">  <p><small>TO SUBMIT A LOCATE REQUEST 24 HRS A DAY, 7 DAYS A WEEK CALL 811 OR 800-382-5544 CALL 2 WORKING DAYS BEFORE YOU DIG. ITS THE LAW.</small></p> </div> <p>H. INDEMNIFICATION AGREEMENT:</p> <p><small>The petitioner/applicant hereby agrees to hold harmless, defend and to indemnify the City of Bloomington from or against all claims, action, damages and expenses, including but not limited to reasonable attorney's fees or any alleged injury and/or death to any person or damage to any property arising, or alleged to have arisen out of any act of commission or omission on the part of the petitioner/applicant, his/her heirs, successors, or assigns regardless of whether such acts are the direct or indirect result of the public right-of-way use pursuant to this permit grant.</small></p> <p>I AFFIRM, UNDER THE PENALTIES FOR PERJURY, THAT THE FOREGOING REPRESENTATIONS ARE TRUE.</p> <p>PRINT NAME: <u>Ryan M. Strauser</u></p> <p>SIGNATURE: <u>Ryan M. Strauser</u></p> <p>DATE: <u>10/3/2022</u></p>
---	--

For Administration Use Only (applicable to CLOSURE approval)

Approved By: _____ BPW City Engineer Director Date: _____

Staff Representative: _____ Phone#: _____ Date: _____



Board of Public Works Staff Report

Project/Event: Request from Strauser Construction for right of way use on E 9th St

Staff Representative: Paul Kehrberg

Petitioner/Representative: Ryan Strauser, Strauser Construction Co., Inc.

Date: October 11, 2022

Report: Strauser Construction will be replacing a retaining wall and sidewalk for Indiana University at 419 N Indiana Ave. The work will be along E 9th St. They will be installing a pedestrian walk around within the parking lane adjacent to the curb to maintain the pedestrian route. Temporary construction fencing will also be installed around the project area. The work is planned for October 10, 2022 to January 6, 2023.

September 23, 2022

City of Bloomington - Board of Public Works

401 N. Morton Street
Bloomington, IN 47404

RE: IU 419 N Indiana- Retaining Wall Replacement
419 N Indiana Avenue
Bloomington, Indiana
Temporary Sidewalk Closures, Non-Metered Parking Lane Closures

Dear Board Members:

Strauser Construction Co., Inc. has been awarded a project at the 419 N Indiana Ave. Building that consists of replacement the retaining wall and sidewalk along the north of the building facing E 9th Street. The project will include sidewalk and retaining wall removal, and a new retaining wall and new sidewalk along E 9th Street.

As part of the project, Strauser Construction Co., Inc. is requesting the use of the right of way for installation of temporary construction fencing and barriers from October 10th, 2022 until January 6, 2023. We would implement a MOT plan that consists of temporary fencing and barriers that would provide a 5' clear walking path directly adjacent to the curb and leave a 12' clear traffic lane for vehicles. Attached is a maintenance of traffic plan provided by Indiana University. The Indiana University proposed MOT will provide a 5' walking path and 12' traffic lane for the duration specified above.

During the course of this project Strauser Construction Co., Inc. will work with the City of Bloomington and City of Bloomington Engineering to minimize disruptions caused by the project. Based on this and the attached MOT information, Strauser Construction Co., Inc. request that the Board of Public Works approves the use of the right of way during the time periods stated above.

Sincerely,

Ryan M. Strauser
RA, AIA, LEED AP

Strauser Construction Co., Inc.
453 S. Clarizz Blvd.
Bloomington, IN 47401

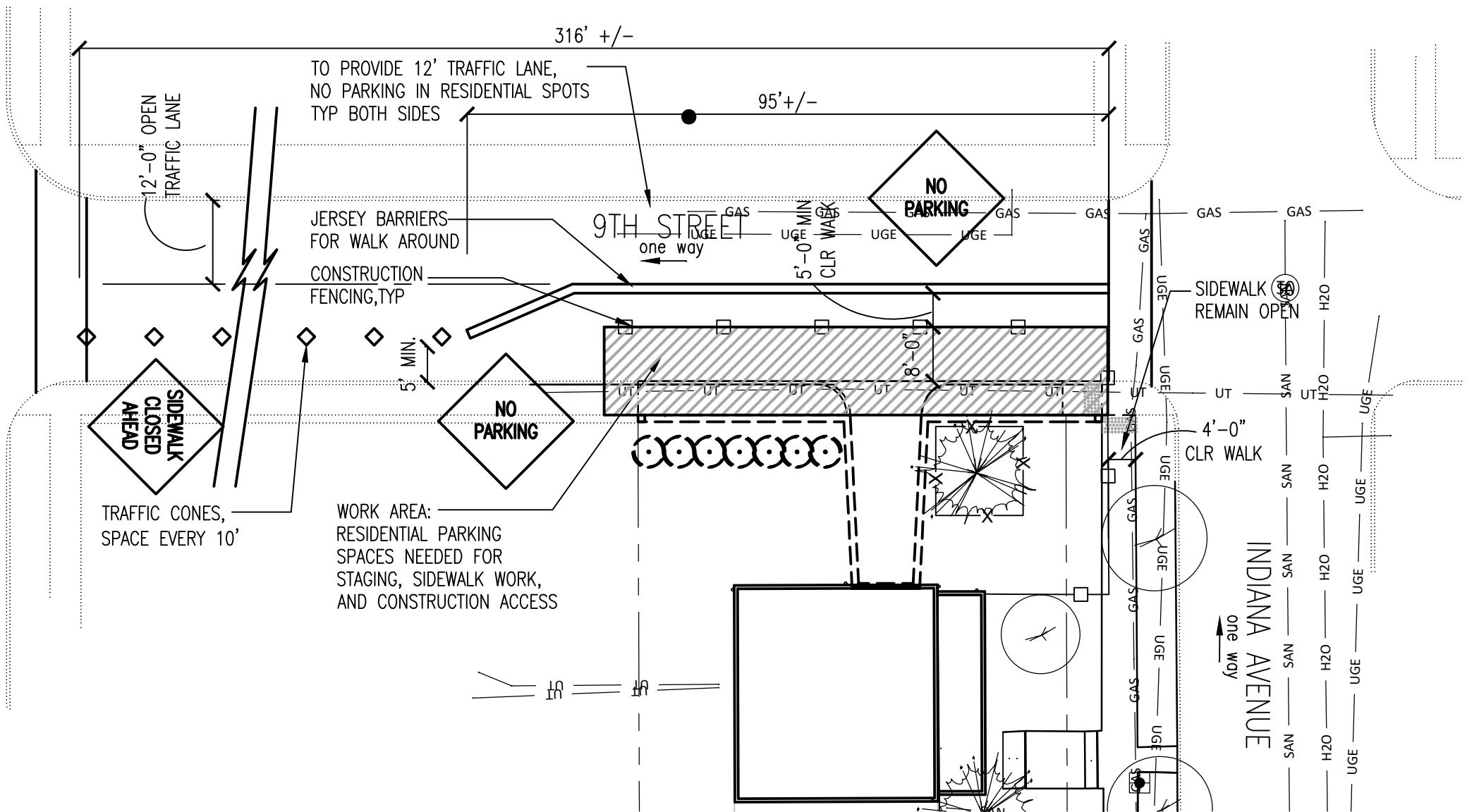

419 N INDIANA MAINTENANCE OF TRAFFIC PLAN

A

SCALE: 1"=10'-0"





CITY OF BLOOMINGTON RIGHT-OF-WAY USE PERMIT APPLICATION

401 N Morton Street, Suite 130
P.O. Box 100
Bloomington, IN 47402

Phone: (812) 349-3913
Fax: (812) 349-3520
Email:
engineering@bloomington.in.gov

ROW EXCAVATION ROW USE

ADDRESS OF ROW ACTIVITY: 419 N Indiana Avenue

A. APPLICANT/AGENT INFORMATION:		D. TRAFFIC CONTROL DEVICES*:	
APPLICANT NAME: <u>Strauser Construction Co., Inc.</u>		<input checked="" type="checkbox"/> CONES / JERSEY BARRIERS <input type="checkbox"/> ARROWBOARD	
E-MAIL: <u>rmstrauser@strausercci.com</u>		<input type="checkbox"/> LIGHTED BARRELS <input type="checkbox"/> TYPE 3 BARRICADES	
COMPANY: <u>Strauser Construction Co., Inc.</u>		<input type="checkbox"/> FLAGGERS <input type="checkbox"/> BPD OFFICER	
ADDRESS: <u>453 S. Clarizz Blvd.</u>		*PROVIDING MUTCD COMPLIANT TEMPORARY TRAFFIC CONTROL DEVICES AND MAINTENANCE OF TRAFFIC (MOT) PLAN IS YOUR RESPONSIBILITY AND REQUIRED. See page 3 for additional MOT resources; the graph paper can be used for your MOT site plan if needed or you can submit a separate sheet	
CITY, STATE, ZIP: <u>Bloomington, IN 47401</u>			
24-HR EMERGENCY CONTACT NAME: <u>Ryan Strauser</u>		E. METERED PARKING SPACES NEEDED: <input type="checkbox"/> Y <input checked="" type="checkbox"/> N	
24-HR CONTACT PHONE #: <u>812-360-1503</u>		IT IS THE RESPONSIBILITY OF THE APPLICANT TO RESERVE PARKING METER(S) APPLICATION LOCATED: https://bloomington.in.gov/transportation/parking/moving OR CONTACT PARKING SERVICES WITH QUESTIONS AT (812)349-3436	
INSURANCE #*: _____ COMPANY: <u>Hylant - Selective</u>		F. IS THIS A <input type="checkbox"/> CBU* <input type="checkbox"/> COUNTY* <input checked="" type="checkbox"/> IU* <input type="checkbox"/> NP* PROJECT?	
BOND #*: _____ COMPANY: <u>Hylant - Nationwide</u>		PROJECT NAME: <u>IU Political Theory - Porch Replacement, 419 N Indiana - Retaining Wall Replacement</u>	
*INSURANCE & BOND MUST BE ON FILE WITH THE CITY BEFORE PERMIT WILL BE ISSUED		PROJECT #: <u>IU #20210370</u>	
SUBCONTRACTOR INFORMATION		PROJECT MGR.: _____	
(LIST ALL COMPANIES WORKING UNDER PRIMARY CONTRACTOR PERMIT)		PROJECT MGR. #: _____	
COMPANY NAME: _____		*CBU = CITY OF BLOOMINGTON UTILITIES *COUNTY = MONROE COUNTY *IU = INDIANA UNIVERSITY *NP = NOT-FOR-PROFIT AGENCY	
B. WORK DESCRIPTION:		G. EXCAVATIONS:	
<input type="checkbox"/> POD/DUMPSTER <input type="checkbox"/> CRANE <input type="checkbox"/> SCAFFOLDING <input checked="" type="checkbox"/> CONSTRUCTION USE*		SQ FT OF PAVEMENT* EXCAVATIONS : <u>345 sf</u>	
(EXPLAIN): <u>Closure of sidewalk for work / replace at completion</u>		*PAVEMENT INCLUDES: IN OR UNDER CONCRETE, OR ASPHALT INCLUDING CURBS	
EXCAVATION, LONG TERM USE FOR STORAGE OF MATERIAL/EQUIPMENT/WALKAROUND		SQ FT OF NON-PAVEMENT EXCAVATIONS: <u>NA</u>	
C. RIGHT OF WAY TO BE USED/CLOSED:		*DIRT, GRASS, GRAVEL, LANDSCAPE AREA OR OTHER UNPAVED SURFACE	
STREET NAME 1: <u>Portion of E 9th St</u>		LINEAL FT OF BORE*: <u>NA</u>	
1ST INTERSECTING STREET NAME: <u>N Indiana Avenue</u>		*BORE PITS SHALL BE CALCULATED AS SQ FT EXCAVATIONS	
2ND INTERSECTING STREET NAME: <u>N Dunn Street</u>		# OF POLE INSTALLATIONS/REMOVAL: <u>NA</u>	
<input type="checkbox"/> ROAD CLOSURE <input type="checkbox"/> LANE CLOSURE 1 <input type="checkbox"/> 2 <input type="checkbox"/> 3 <input type="checkbox"/>		SQ FT OF SIDEWALK RECONSTRUCTION*: <u>345 sf</u>	
<input checked="" type="checkbox"/> SIDEWALK* <input type="checkbox"/> BIKE LANE <input checked="" type="checkbox"/> OTHER PARKING LANES		*CONCRETE OR ASPHALT SIDEWALK/PATH BEING IMPROVED/REPLACED	
TRANSIT STOP? <input type="checkbox"/> Y <input checked="" type="checkbox"/> N PARKING LANE(S)** <input checked="" type="checkbox"/> Y <input type="checkbox"/> N **NON-METERED		SQ FT OF SIDEWALK NEW CONSTRUCTION*: <u>NA</u>	
START DATE: <u>10/10/22</u> END DATE: <u>01/06/22</u> # OF DAYS*: <u>89</u>		*CONCRETE OR ASPHALT SIDEWALK/PATH THAT IS NEW INFRASTRUCTURE	
STREET NAME 2: _____		#RESIDENTIAL DRIVEWAY INSTALLATION: <u>NA</u>	
1ST INTERSECTING STREET NAME: _____		 <p>TO SUBMIT A LOCATE REQUEST 24 HRS A DAY, 7 DAYS A WEEK CALL 811 OR 800-382-5544 CALL 2 WORKING DAYS BEFORE YOU DIG. ITS THE LAW.</p>	
2ND INTERSECTING STREET NAME: _____			
<input type="checkbox"/> ROAD CLOSURE <input type="checkbox"/> LANE CLOSURE 1 <input type="checkbox"/> 2 <input type="checkbox"/> 3 <input type="checkbox"/>		H. INDEMNIFICATION AGREEMENT:	
<input type="checkbox"/> SIDEWALK* <input type="checkbox"/> BIKE LANE <input type="checkbox"/> OTHER		The petitioner/applicant hereby agrees to hold harmless, defend and to indemnify the City of Bloomington from or against all claims, action, damages and expenses, including but not limited to reasonable attorney's fees or any alleged injury and/or death to any person or damage to any property arising, or alleged to have arisen out of any act of commission or omission on the part of the petitioner/applicant, his/her heirs, successors, or assigns regardless of whether such acts are the direct or indirect result of the public right-of-way use pursuant to this permit grant.	
TRANSIT STOP? <input type="checkbox"/> Y <input type="checkbox"/> N PARKING LANE(S)** <input type="checkbox"/> Y <input type="checkbox"/> N **NON-METERED		I AFFIRM, UNDER THE PENALTIES FOR PERJURY, THAT THE FOREGOING REPRESENTATIONS ARE TRUE.	
START DATE: _____ END DATE: _____ # OF DAYS*: _____		PRINT NAME: <u>Ryan M. Strauser</u>	
*SIDEWALK CLOSURES FOR A PERIOD OR PERIODS TOTALING 24HRS OR MORE SHALL INSTALL A WALKAROUND UNLESS OTHERWISE APPROVED DURING REVIEW		SIGNATURE: <u>Ryan M. Strauser</u>	
STANDARD CLOSURE HOURS MON-FRI*: 9:00 AM - 3:00 PM & 6:00 PM - 9:00 PM		DATE: <u>08/23/2022</u>	
STANDARD CLOSURE HOURS <input type="checkbox"/> *NON-STANDARD CLOSURE HOURS <input type="checkbox"/>			
REQUESTED CLOSURE HOURS: <u>24 hours</u> AM - _____ PM			
*non-standard hours may not be allowed near schools, on arterials, or other circumstances and are subject to approval during the permitting process			
BMC 14.09.040 allows work from 6 AM to 10 PM without violating the noise ordinance (7AM to 9PM for pneumatic hammers)			

For Administration Use Only (applicable to CLOSURE approval)

Approved By: _____ BPW City Engineer Director Date: _____

Staff Representative: _____ Phone#: _____ Date: _____



Board of Public Works

Staff Report

Project/Event: Award Contract for No Turn on Red Project
Petitioner/Representative: Public Works/Street Division
Staff Representative: Joe VanDeventer
Date: October 11, 2022

This contract will provide material & installation of 76 - No Turn on Red signs at signalized locations within the City.

Two quotes were received on Friday, September 23, 2022 dividing into 3 project sections.

Ragel, Inc.

Section 1 \$ 22,475.00

Section 2 \$ 18,125.00

Section 3 \$ 14,500.00

TOTAL PROJECT \$ 55,100.00

TAPCO, Traffic & Parking Control Co., Inc.

Section 1 \$ 18,290.00

Section 2 \$ 14,750.00

Section 3 \$ 11,800.00

TOTAL PROJECT \$ 44,840.00

No Response – Midwestern Electric

No Response – Signal Construction

TAPCO was determined to be the lowest responsible and responsive RFQ for the 2022 No Turn on Red Sign Project.

City of Bloomington Contract and Purchase Justification Form

Vendor: TAPCO, Traffic & Parking
Control Co., Inc.

Contract Amount: \$ 44,840.00

This form should be completed and attached to the contract documents and forwarded to the Legal Department Attorney assigned to your Department. Contracts will not be approved by the Controller if a completed form is not included with the contract documents.

PURCHASE INFORMATION

1. Check the box beside the procurement method used to initiate this procurement: (Attach a quote or bid tabulation if applicable)

<input checked="" type="checkbox"/> Request for Quote (RFQ)	<input type="checkbox"/> Request for Proposal (RFP)	<input type="checkbox"/> Sole Source	<input type="checkbox"/> Not Applicable (NA)
<input type="checkbox"/> Invitation to Bid (ITB)	<input type="checkbox"/> Request for Qualifications (RFQu)	<input type="checkbox"/> Emergency Purchase	

2. List the results of procurement process. Give further explanation where requested.

	Yes	No		Yes	No
# of Submittals: 2	<input type="checkbox"/>	<input type="checkbox"/>	Was the lowest cost selected? (If no, please state below why it was not.)	<input checked="" type="checkbox"/>	<input type="checkbox"/>
Met city requirements?	<input checked="" type="checkbox"/>	<input type="checkbox"/>			
Met item or need requirements?	<input checked="" type="checkbox"/>	<input type="checkbox"/>			
Was an evaluation team used?	<input type="checkbox"/>	<input checked="" type="checkbox"/>			
Was scoring grid used?	<input type="checkbox"/>	<input checked="" type="checkbox"/>			
Were vendor presentations requested?	<input type="checkbox"/>	<input checked="" type="checkbox"/>			

3. State why this vendor was selected to receive the award and contract:

Two quotes were received on September 23, 2022. TAPCO, Traffic & Parking Control Co., Inc. was the most responsible and responsive RFQ.

RFQ were sent out to the following contractors.

Ragel, Inc.
TAPCO, Traffic & Parking Control Co., Inc.
Midwestern Electric
Signal Construction

Joe VanDeventer

Director of Street Operations

Public Works/Street Division

Print/Type Name

Print/Type Title

Department

**SERVICE AGREEMENT BETWEEN PUBLIC WORKS DEPARTMENT
AND TAPCO, Traffic & Parking Control Co, Inc.**

This Agreement, entered into on this 11th day of October, 2022, by and between the City of Bloomington Department of Public Works (the “Department”), and TAPCO, Traffic & Parking Control Co., Inc. (“Contractor”).

Article 1. Scope of Services After receiving a **Notice to Proceed**, Contractor shall perform repair and maintenance services of the following types: Providing material and installation of 76 No Turn on Red Signs (R10-11) at signalized intersections within the City. Contractor shall diligently provide the Services under this Agreement and shall complete the Services described in this Agreement in a timely manner consistent with the Standard of Care identified in Article 2. Contractor shall complete the Services required under this Agreement on or before December 31, 2022, unless the parties mutually agree to a later completion date. Completion shall mean completion of all work related to the Services. In the performance of Contractor’s work, Contractor agrees to maintain such coordination with the Department as may be requested and desirable, including primary coordination with Joe Van Deventer, Director of Street Operations, Public Works Department. Contractor agrees that any information or documents, including digital GIS information, supplied by the Department pursuant to Article 3, below, shall be used by Contractor for this project only, and shall not be reused or reassigned for any other purpose without the written permission of the Department.

Article 2. Standard of Care Contractor shall be responsible for completion of the Services in a manner consistent with that degree of care and skill ordinarily exercised by members of the same profession currently practicing under similar circumstances (“Standard of Care”). The Department shall be the sole judge of the adequacy of Contractor’s work in meeting the Standard of Care; however, the Department shall not unreasonably withhold its approval as to the adequacy of Contractor’s performance. Upon notice to Contractor and by mutual agreement between the parties, Contractor will, without additional compensation, correct or replace any and all Services not meeting the Standard of Care.

Article 3. Responsibilities of the Department The Department shall provide all necessary information regarding requirements for the Services. The Department shall furnish such information as necessary for the orderly progress of the work, and Contractor shall be entitled to rely upon the accuracy and completeness of such information. The Department’s Project Manager shall act on its behalf with respect to this Agreement.

Article 4. Compensation The Department shall pay Contractor for all fees and expenses in an amount not to exceed Forty-four Thousand Eight Hundred Forty Dollars (\$ 44,840.00). Contractor shall submit an invoice to the Department upon the completion of the Services described in Article 1. **Invoices shall be sent via email to publicworks@bloomington.in.gov or via first class mail postage prepaid to Public Works Department, 401 N. Morton Street, Suite 120, Bloomington, IN 47404.** The invoice shall be sent to: Joe Van Deventer, City of Bloomington Public Works, 401 N. Morton, Suite 120, Bloomington, Indiana 47404. Invoices may be sent via first class mail postage prepaid or via email. Payment will be remitted to Contractor within forty-five (45) days of receipt of invoice. Additional services not set forth in Article 1, or changes in the Services must be authorized in writing by the Department or its designated project coordinator prior to such work being performed, or expenses incurred. The Department shall not make payment for any unauthorized work or expenses.

Article 5. Appropriation of Funds Notwithstanding any other provision of this Agreement, if funds for the continued fulfillment of this Agreement by the Department are at any time not forthcoming or are insufficient, through failure of any entity, including the Department itself, to appropriate funds or otherwise, then the Department shall have the right to terminate this Agreement without penalty.

Article 6. Schedule Contractor shall perform the Services according to the following schedule:

The time limits established by this schedule shall not be exceeded, except for reasonable cause as mutually agreed to by all parties.

Article 7. Termination In the event of a party's substantial failure to perform in accordance with the terms of this Agreement, the other party shall have the right to terminate the Agreement upon written notice. The nonperforming party shall have fourteen (14) calendar days from the receipt of the termination notice to cure or to submit a plan for cure acceptable to the other party. Additionally, the Department may terminate or suspend performance of this Agreement at the Department's prerogative at any time upon written notice to Contractor. Contractor shall terminate or suspend performance of the Services on a schedule acceptable to the Department and the Department shall pay the Contractor for all the Services performed up to the date that written notice is received, plus reasonable termination or suspension expenses. Upon restart, an equitable adjustment shall be made to Contractor's compensation and the schedule of services. Upon termination or suspension of this Agreement, all finished or unfinished reports, drawings, collections of data and other documents generated by Contractor in connection with this Agreement shall become the property of the Department, as set forth in Article 9 herein.

Article 8. Identity of the Contractor Contractor acknowledges that one of the primary reasons for its selection by the Department to perform the Services is the qualifications and experience of Contractor. Contractor thus agrees that the Services to be performed pursuant to this Agreement shall be performed by Contractor. Contractor shall not subcontract any part of the Services without the prior written permission of the Department. The Department reserves the right to reject any of the Contractor's personnel or proposed outside professional sub-Contractors, and the Department reserves the right to request that acceptable replacement personnel be assigned to the project.

Article 9. Ownership of Documents and Intellectual Property All documents, drawings and specifications, including digital format files, prepared by Contractor and furnished to the Department as part of the Services shall become the property of the Department. Contractor shall retain its ownership rights in its design, drawing details, specifications, databases, computer software and other proprietary property. Intellectual property developed, utilized or modified in the performance of the Services shall remain the property of Contractor.

Article 10. Independent Contractor Status During the entire term of this Agreement, Contractor shall be an independent contractor, and in no event shall any of its personnel, agents or sub-contractors be construed to be, or represent themselves to be, employees of the Department. Contractor shall be solely responsible for the payment and reporting of all employee and employer taxes, including social security, unemployment, and any other federal, state, or local taxes required to be withheld from employees or payable on behalf of employees.

Article 11. Indemnification Contractor shall indemnify and hold harmless the City of Bloomington, the Department, and the officers, agents and employees of the City and the Department from any and all claims, demands, damages, costs, expenses or other liability arising out of the Agreement or occasioned by the reckless or negligent performance of any provision thereof, including, but not limited to, any reckless or negligent act or failure to act or any misconduct on the part of the Contractor or its agents or employees, or any independent contractors directly responsible to it (collectively "Claims").

Article 12. Insurance During the performance of any and all Services under this Agreement, Contractor shall maintain the following insurance in full force and effect: a) General Liability Insurance, with a minimum combined single limit of \$1,000,000 for each occurrence and \$2,000,000 in the aggregate; b) Automobile Liability Insurance, with a minimum combined single limit of \$1,000,000 for each person and \$1,000,000 for each accident; c) Workers' Compensation Insurance in accordance with the statutory requirements of Title 22 of the Indiana Code; and d) Professional Liability Insurance ("Errors and Omissions Insurance") with a minimum limit of \$1,000,000 annual aggregate. All insurance policies shall be issued by an insurance company authorized to issue such insurance in the State of Indiana. The City of

Bloomington, the Department, and the officers, employees and agents of each shall be named as insureds under the General Liability, Automobile, and Worker's Compensation policies, and such policies shall stipulate that the insurance will operate as primary insurance and that no other insurance of the City's will be called upon to contribute to a loss hereunder. Contractor shall provide evidence of each insurance policy to the Department prior to the commencement of work under this Agreement.

Article 13. Conflict of Interest Contractor declares that it has no present interest, nor shall it acquire any interest, direct or indirect, which would conflict with the performance of Services under this Agreement. Contractor agrees that no person having any such interest shall be employed in the performance of this Agreement.

Article 14. Waiver No failure of either party to enforce a term of this Agreement against the other shall be construed as a waiver of that term, nor shall it in any way affect the party's right to enforce that term. No waiver by any party of any term of this Agreement shall be considered to be a waiver of any other term or breach thereof.

Article 15. Severability The invalidity, illegality or unenforceability of any provision of this Agreement or the occurrence of any event rendering any portion or provision of this Agreement void shall in no way affect the validity or enforceability of any other portion or provision of this Agreement. Any void provision shall be deemed severed from this Agreement, and the balance of the Agreement shall be construed and enforced as if it did not contain the particular provision to be held void. The parties further agree to amend this Agreement to replace any stricken provision with a valid provision that comes as close as possible to the intent of the stricken provision. The provisions of this Article shall not prevent this entire Agreement from being void should a provision which is of the essence of this Agreement be determined void.

Article 16. Assignment Neither the Department nor the Contractor shall assign any rights or duties under this Agreement without the prior written consent of the other party. Unless otherwise stated in the written consent to an assignment, no assignment will release or discharge the assignor from any obligation under this Agreement.

Article 17. Third Party Rights Nothing in this Agreement shall be construed to give any rights or benefits to anyone other than the parties.

Article 18. Governing Law and Venue This Agreement shall be governed by the laws of the State of Indiana. Venue of any disputes arising under this Agreement shall be in the Monroe Circuit Court, Monroe County, Indiana.

Article 19. Non-Discrimination Contractor shall comply with City of Bloomington Ordinance 2.21.020 and all other federal, state and local laws and regulations governing non-discrimination in all regards, including, but not limited to, employment. Contractor understands that the City of Bloomington prohibits its employees from engaging in harassment or discrimination of any kind, including harassing or discriminating against independent contractors doing work for the City. If the Contractor believes that a City employee engaged in such conduct towards Contractor and/or any of its employees, Contractor or its employees may file a complaint with the City department head in charge of the Contractor's work and/or with the City human resources department or the Bloomington Human Rights Commission. The City takes all complaints of harassment and discrimination seriously and will take appropriate disciplinary action if it finds that any City employee engaged in such prohibited conduct.

Article 20. Compliance with Laws In performing the Services under this Agreement, Contractor shall comply with any and all applicable federal, state and local statutes, ordinances, plans and regulations, including any and all regulations for protection of the environment. Where such statutes, ordinances, plans

or regulations of any public authority having any jurisdiction over the project are in conflict, Contractor shall proceed using its best judgment only after attempting to resolve any such conflict between such governmental agencies, and shall notify the Department in a timely manner of the conflict, attempts of resolution, and planned course of action.

Article 21. E-Verify Contractor is required to enroll in and verify the work eligibility status of all newly-hired employees through the E-Verify program. (This is not required if the E-Verify program no longer exists). Contractor shall sign an affidavit, attached as Exhibit A, affirming that Contractor does not knowingly employ an unauthorized alien. Contractor shall require any subcontractors performing work under this contract to certify to the Contractor that, at the time of certification, the subcontractor does not knowingly employ or contract with an unauthorized alien and the subcontractor has enrolled in and is participating in the E-Verify program. Contractor shall maintain on file all subcontractors' certifications throughout the term of the contract with the City.

Article 22. Notices Any notice required by this Agreement shall be made in writing to the individuals/addresses specified below:

Department: City of Bloomington Public Works, Attn: Joe Van Deventer, 401 N. Morton, Suite 120, Bloomington, Indiana 47404.

Contractor: TAPCO (Traffic & Parking Control Co, Inc. Attn: Bryan Everard, 5100 E Brown Deer Road, Browndeer, WI 53223

Nothing contained in this Article shall be construed to restrict the transmission of routine communications between representatives of the Department and Contractor.

Article 23. Integration and Modification This Agreement, including all Exhibits incorporated by reference, represents the entire and integrated agreement between the Department and the Contractor. It supersedes all prior and contemporaneous communications, representations and agreements, whether oral or written, relating to the subject matter of this Agreement. This Agreement may be modified only by a written amendment signed by both parties hereto.

Article 24. Non-Collusion Contractor is required to certify that it has not, nor has any other member, representative, or agent of Contractor, entered into any combination, collusion, or agreement with any person relative to the price to be offered by any person nor prevented any person from making an offer nor induced anyone to refrain from making an offer and that this offer is made without reference to any other offer. Contractor shall sign an affidavit, attached hereto as Exhibit B, affirming that Contractor has not engaged in any collusive conduct. Exhibit B is attached hereto and incorporated by reference as though fully set forth.

Article 25: Renewal This Agreement may be renewed for two additional one-year terms so long as none of the terms and conditions herein are modified in any way. Renewal shall only occur upon advanced written notice by the City to the Contractor that the City wishes to renew the Agreement at least thirty (30) days, but not more than sixty (60) days, prior to the end of the current term

CITY OF BLOOMINGTON

TAPCO (Traffic & Parking Control Co., Inc.

Beth Cate, Corporation Counsel

Andy Bergholz, Co-Owner, President

Adam Wason, Director, Public Works Department

Kayla Cox Deckard, President, Board of Public Works

EXHIBIT B

STATE OF INDIANA)
) SS:
COUNTY OF _____)

NON-COLLUSION AFFIDAVIT

The undersigned offeror or agent, being duly sworn on oath, says that he has not, nor has any other member, representative, or agent of the firm, company, corporation or partnership represented by him, entered into any combination, collusion or agreement with any person relative to the price to be offered by any person nor to prevent any person from making an offer nor to induce anyone to refrain from making an offer and that this offer is made without reference to any other offer.

OATH AND AFFIRMATION

I affirm under the penalties of perjury that the foregoing facts and information are true and correct to the best of my knowledge and belief.

Dated this _____ day of _____, 20____.

TAPCO, Traffic & Parking Control Co., Inc.

By: _____

STATE OF INDIANA)
) SS:
COUNTY OF _____)

Before me, a Notary Public in and for said County and State, personally appeared _____ and acknowledged the execution of the foregoing this _____ day of _____, 2022.

Notary Public Printed Name

Notary Public's Signature

My Commission Expires: _____

County of Residence: _____

My Commission #: _____



Board of Public Works Claim Register

Invoice Date Range 10/01/22 - 10/14/22

Vendor	Invoice Description	Contract #	Payment Date	Invoice Amount
Fund 101 - General Fund (S0101)				
Department 01 - Animal Shelter				
Program 010000 - Main				
Account 43430 - Animal Adoption Fees				
Nakiah McArtor	01-returned adoption fee-9/22/22		10/14/2022	75.00
Account 43430 - Animal Adoption Fees Totals			Invoice 1	<u>75.00</u>
			Transactions	
Account 43442 - Equipment Deposits				
Austin Clayton	01-refund trap deposit-9/22/22		10/14/2022	40.00
Alex Henderson	01-refund trap deposit-9/27/22		10/14/2022	40.00
Account 43442 - Equipment Deposits Totals			Invoice 2	<u>80.00</u>
			Transactions	
Account 52110 - Office Supplies				
6530 - Office Depot, INC	01-Card Stock & Color Paper		10/14/2022	191.07
453 - ULINE, INC	01-Desk Chair		10/14/2022	104.73
Account 52110 - Office Supplies Totals			Invoice 2	<u>295.80</u>
			Transactions	
Account 52210 - Institutional Supplies				
4586 - Hill's Pet Nutrition Sales, INC	01-puppy & kitten food		10/14/2022	144.03
4586 - Hill's Pet Nutrition Sales, INC	01-Cat Food		10/14/2022	274.62
4586 - Hill's Pet Nutrition Sales, INC	01-dog/puppy/cat/kitten food		10/14/2022	387.44
3929 - IDEXX Laboratories, INC	01-Parvo & Heartworm Tests		10/14/2022	768.70
4549 - Kroger Limited Partnership I	01-rabbit food, shelter supplies		10/14/2022	17.18
4633 - Midwest Veterinary Supply, INC	01-Veterinary Supplies-thermometer		10/14/2022	11.67



Board of Public Works Claim Register

Invoice Date Range 10/01/22 - 10/14/22

4633 - Midwest Veterinary Supply, INC	01-Veterinary Supplies-rabbit food	10/14/2022	15.61
4633 - Midwest Veterinary Supply, INC	01-Veterinary Supplies-rabbit food	10/14/2022	40.66
4633 - Midwest Veterinary Supply, INC	01-Veterinary Supplies-syringes	10/14/2022	74.55
4633 - Midwest Veterinary Supply, INC	01-Veterinary Supplies-gloves, food trays, antibiotics. shampoo	10/14/2022	81.98
4633 - Midwest Veterinary Supply, INC	01-Veterinary Supplies-syringes	10/14/2022	89.85
4633 - Midwest Veterinary Supply, INC	01-Veterinary Supplies-antibiotics, syringes, Trazodone	10/14/2022	340.68
4633 - Midwest Veterinary Supply, INC	01-Veterinary Supplies-antibiotics, milk replacer, syringes	10/14/2022	594.73
4633 - Midwest Veterinary Supply, INC	01-Veterinary Supplies-antifungal, antibiotics, vet wrap	10/14/2022	637.44
5819 - Synchrony Bank	01-Lime Dip, Accel Hydro Shampoo, Toothbrushes	10/14/2022	29.95
5819 - Synchrony Bank	01-Dishwasher Soap, Heating Packs	10/14/2022	51.98
5819 - Synchrony Bank	01-Lime Dip, Accel Hydro Shampoo, Toothbrushes	10/14/2022	54.99
5819 - Synchrony Bank	01-Dishwasher Soap, Heating Packs	10/14/2022	92.11
5819 - Synchrony Bank	01-Lime Dip, Accel Hydro Shampoo, Toothbrushes	10/14/2022	103.10
4666 - Zoetis, INC	01-Vaccinations & Anti-Parasitics	10/14/2022	1,432.95
Account 52210 - Institutional Supplies Totals		Invoice 20 Transactions	\$5,244.22
Account 52310 - Building Materials and Supplies			
313 - Fastenal Company	01-Trash Liners, Mops & Shelter Supplies	10/14/2022	308.97
453 - ULINE, INC	01-Desk Chair	10/14/2022	202.29
Account 52310 - Building Materials and Supplies Totals		Invoice 2 Transactions	\$511.26
Account 52340 - Other Repairs and Maintenance			
394 - Kleindorfer Hardware & Variety	01-Shelter Parts; Repair Supplies	10/14/2022	15.98
Account 52340 - Other Repairs and Maintenance Totals		Invoice 1 Transactions	\$15.98



Board of Public Works Claim Register

Invoice Date Range 10/01/22 - 10/14/22

Account 52430 - Uniforms and Tools

4832 - Animal Care Equipment & Services, LLC	01-Safe Animal Handling Equipment	10/14/2022	243.35
4447 - Municipal Emergency Services, INC	01-Uniform Scrubs	10/14/2022	110.15
Account 52430 - Uniforms and Tools Totals			Invoice 2 Transactions \$353.50

Account 53130 - Medical

54639 - Shake Veterinary Services, INC (Town & Country Vet	01-Diagnostics, Surgeries & Other Vet Services	10/14/2022	679.66
Account 53130 - Medical Totals			Invoice 1 Transactions \$679.66

Account 53220 - Postage

3560 - First Financial Bank / Credit Cards	01-BOH Shipping-9/8/2022	10/14/2022	12.15
3560 - First Financial Bank / Credit Cards	01-BOH Shipping-8/31/22	10/14/2022	25.23
Account 53220 - Postage Totals			Invoice 2 Transactions \$37.38

Account 53610 - Building Repairs

6378 - ANN-KRISS, LLC	19-SA Repair Upper & Lower Fence & Gate @ ACC	BC 2021-122	10/14/2022	2,500.00
321 - Harrell Fish, INC (HFI)	19-SA-ACC-After-Hours Repair of AC in Foyer & part of building	BC 2021-111	10/14/2022	700.97
321 - Harrell Fish, INC (HFI)	19-SA Repaired BFP Failed Device @ ACC	BC 2021-111	10/14/2022	557.99
Account 53610 - Building Repairs Totals			Invoice 3 Transactions \$3,758.96	

Account 53990 - Other Services and Charges

4045 - Datamars, INC	01-Microchip Registrations	10/14/2022	49.95
Account 53990 - Other Services and Charges Totals			Invoice 1 Transactions \$49.95
Program 010000 - Main Totals			Invoice 37 Transactions \$11,101.71

Program 010001 - Donations Over \$5K

Account 52210 - Institutional Supplies



Board of Public Works Claim Register

Invoice Date Range 10/01/22 - 10/14/22

4586 - Hill's Pet Nutrition Sales, INC

01-Prescription Food 10/14/2022 145.32

Account **52210 - Institutional Supplies** Totals Invoice 1 \$145.32
Transactions

Account **53130 - Medical**

6529 - BloomingPaws, LLC

01-Diagnostics, Surgeries & Other Vet Services 10/14/2022 553.78

Account **53130 - Medical** Totals Invoice 1 \$553.78
Transactions

Program **010001 - Donations Over \$5K** Totals Invoice 2 \$699.10
Transactions

Department **01 - Animal Shelter** Totals Invoice 39 \$11,800.81
Transactions

Department **02 - Public Works**

Program **020000 - Main**

Account **52420 - Other Supplies**

6222 - Apple, INC

02-Airpods with Charging Case/DPW Director 10/14/2022 208.00

Account **52420 - Other Supplies** Totals Invoice 1 \$208.00
Transactions

Account **53170 - Mgt. Fee, Consultants, and Workshops**

17 - Bynum Fanyo & Associates, INC

02 & 20-PE-6th-Morton Alley Reno Design/Amend-9/16/22 BC 2021-82 10/14/2022 30,803.00

208 - City Of Bloomington Utilities

02-Cost Sharing MOU w/CBU for Street Sweeping Study BC 2022-050 10/14/2022 10,000.00

7146 - Routeware, INC

02-Annual Fee for ReCollect Sanitation Software-12/1/22-11/30/23 BC 2021-85 10/14/2022 12,741.12

Account **53170 - Mgt. Fee, Consultants, and Workshops** Totals Invoice 3 \$53,544.12
Transactions

Account **53230 - Travel**

2820 - Nathan Nickel

02- Travel Expenses for 2022 ICMA Conference 10/14/2022 850.89

Account **53230 - Travel** Totals Invoice 1 \$850.89
Transactions

Program **020000 - Main** Totals Invoice 5 \$54,603.01
Transactions

Program **02RCVR - Recover Forward**



Board of Public Works Claim Register

Invoice Date Range 10/01/22 - 10/14/22

Account 53990 - Other Services and Charges

7627 - River Town Construction, LLC	07-Neighborhood Greenways Project PH I-7/21-7/30/22-App #3	BC 2021-157	10/14/2022	88,716.02
			Account 53990 - Other Services and Charges Totals	Invoice 1
				Transactions
				\$88,716.02

Account 54310 - Improvements Other Than Building

6611 - Precision Concrete, INC	20-Services for sidewalk grinding	BC 2021-149	10/14/2022	10,282.56
				Addem#2021-149 Recover Forward
			Account 54310 - Improvements Other Than Building Totals	Invoice 1
				Transactions
				\$10,282.56
			Program 02RCVR - Recover Forward Totals	Invoice 2
				Transactions
				\$98,998.58
			Department 02 - Public Works Totals	Invoice 7
				Transactions
				\$153,601.59

Department 03 - City Clerk

Program 030000 - Main

Account 53310 - Printing

6309 - CivicPlus, LLC	03-Online Code Hosting-10/1/22-9/30/23		10/14/2022	200.00
			Account 53310 - Printing Totals	Invoice 1
				Transactions
				\$200.00
			Program 030000 - Main Totals	Invoice 1
				Transactions
				\$200.00
			Department 03 - City Clerk Totals	Invoice 1
				Transactions
				\$200.00

Department 04 - Economic & Sustainable Dev

Program 040000 - Main

Account 53160 - Instruction

7080 - Urban Sustainability Directors Network	04: USDN 2022 Regional Meeting Reg - M.Lynch		10/14/2022	250.00
7080 - Urban Sustainability Directors Network	04: USDN Conference - Lauren Clemens		10/14/2022	250.00
			Account 53160 - Instruction Totals	Invoice 2
				Transactions
				\$500.00

Account 53230 - Travel



Board of Public Works Claim Register

Invoice Date Range 10/01/22 - 10/14/22

3560 - First Financial Bank / Credit Cards	04: Hotel (Comfort Inn) M.Lynch 9/8/22 - Conference	10/14/2022	94.75
8395 - McKaylyn Lynch	04-Travel Reimbursement McKaylyn Lynch-Richmond-9/8-9/9/22	10/14/2022	93.75
Account 53230 - Travel Totals		Invoice 2	<u>\$188.50</u>
		Transactions	
Account 53910 - Dues and Subscriptions			
3560 - First Financial Bank / Credit Cards	04-Subscription to MailChimp - marketing tool	10/14/2022	17.00
Account 53910 - Dues and Subscriptions Totals		Invoice 1	<u>\$17.00</u>
		Transactions	
Account 53970 - Mayor's Promotion of Business			
8393 - Opeyemi Adeyonu	04: Performance at Black Y Brown Arts Festival	10/14/2022	100.00
8378 - Alese Allen	04: Performance at Black Y Brown Arts Festival - Alese Allen	10/14/2022	100.00
8382 - Breona Baggett (Moodaxo)	04: Performance at Black Y Brown Arts Festival - Baggett	10/14/2022	100.00
8381 - Stafford C Berry, JR	04: Performance at Black Y Brown Arts Festival - S.Berry	10/14/2022	500.00
4505 - Bicycle Garage, INC	04: eBike for Registrant Drawing Award - Go Bloomington	10/14/2022	2,849.99
8379 - Sofia Crespo	04: Performance at Black Y Brown Arts Festival - Crespo	10/14/2022	250.00
3560 - First Financial Bank / Credit Cards	04-Michaels-Art supplies for ByB Festival	10/14/2022	109.96
7799 - David Davila Gonzalez	04: Performance at Black Y Brown Arts Festival - Gonzalez	10/14/2022	1,000.00
3404 - J.R. Watkins & Family, INC (Signs Now)	04-Hardware - 18" pole brackets for Go Bloomington banners	10/14/2022	222.00
3404 - J.R. Watkins & Family, INC (Signs Now)	04-Installation of 25 Go Bloomington banners	10/14/2022	1,237.50
8369 - Ramon Jackson	04: RJackson Band Performance @ Black y Brown Festival	10/14/2022	1,000.00
4549 - Kroger Limited Partnership I	04: Credit for Sales Tax	10/14/2022	(.41)
8380 - Lisa Kwong	04: Performance at Black Y Brown Arts Festival - Kwong	10/14/2022	250.00
8377 - Patrick C Steward (PDVNCH)	04: Performance at Black Y Brown Arts Festival -PDVNCH	10/14/2022	250.00
Account 53970 - Mayor's Promotion of Business Totals		Invoice 14	<u>\$7,969.04</u>
		Transactions	



Board of Public Works Claim Register

Invoice Date Range 10/01/22 - 10/14/22

Account 53990 - Other Services and Charges

3560 - First Financial Bank / Credit Cards	04-Refreshments for Arts Feasibility Study Event	10/14/2022	76.96
Account 53990 - Other Services and Charges Totals		Invoice 1	<u>\$76.96</u>
Program 040000 - Main Totals		Transactions Invoice 20	<u>\$8,751.50</u>
		Transactions	

Program 04WALD - Waldron Arts Center

Account 53610 - Building Repairs

4443 - The Sherwin Williams Company	04: paint for Waldron stairwell	10/14/2022	6,630.69
Account 53610 - Building Repairs Totals		Invoice 1	<u>\$6,630.69</u>
Program 04WALD - Waldron Arts Center Totals		Transactions Invoice 1	<u>\$6,630.69</u>
Department 04 - Economic & Sustainable Dev Totals		Transactions Invoice 21	<u>\$15,382.19</u>
		Transactions	

Department 06 - Controller's Office

Program 060000 - Main

Account 53730 - Machinery and Equipment Rental

371 - Pitney Bowes, INC	06-Mail Meter Rental 6/30/2022-9/29/2022	10/14/2022	120.00
Account 53730 - Machinery and Equipment Rental Totals		Invoice 1	<u>\$120.00</u>
		Transactions	

Account 53910 - Dues and Subscriptions

3560 - First Financial Bank / Credit Cards	06-GFOA eGAAFR 2022 report	10/14/2022	129.00
Account 53910 - Dues and Subscriptions Totals		Invoice 1	<u>\$129.00</u>
Program 060000 - Main Totals		Transactions Invoice 2	<u>\$249.00</u>
Department 06 - Controller's Office Totals		Transactions Invoice 2	<u>\$249.00</u>
		Transactions	

Department 07 - Engineering

Program 070000 - Main



Board of Public Works Claim Register

Invoice Date Range 10/01/22 - 10/14/22

Account 52110 - Office Supplies

6530 - Office Depot, INC	07-CREDIT-return items- INV#263567401001	10/14/2022	(29.96)
6530 - Office Depot, INC	07-Letter opener	10/14/2022	3.52
6530 - Office Depot, INC	07-Scissors, post it, notebook, staple remover	10/14/2022	29.96
Account 52110 - Office Supplies Totals		Invoice 3 Transactions	\$3.52

Account 52420 - Other Supplies

5819 - Synchrony Bank	07-Amazon_Jabra Wireless Headset (Jason Kerr)	10/14/2022	139.99
Account 52420 - Other Supplies Totals		Invoice 1 Transactions	\$139.99

Account 53990 - Other Services and Charges

3560 - First Financial Bank / Credit Cards	07-doxpop_Public Record Access Subscription 9/13 #970806	10/14/2022	15.00
8288 - Kurt Schoch (Performance Improvement Consulting LLC)	07-2022 Engineering Strategic Retreat	10/14/2022	875.00
Account 53990 - Other Services and Charges Totals		Invoice 2 Transactions	\$890.00

Account 54110 - Land Purchase

8028 - Fields, Rudy D. and Laura Kay	07-ROW-B-Line Trail Multi-Use Path-Parcel 12	10/14/2022	1,000.00
Seminary Square, LLC	07-ROW 1st ST Reconstruction-#1900399- Parcel 10	10/14/2022	4,700.00
SF Canadian, LLC	07-ROW 1st ST Reconstruction-#1900399- Parcel 11	10/14/2022	10,550.00
Account 54110 - Land Purchase Totals		Invoice 3 Transactions	\$16,250.00

Account 54310 - Improvements Other Than Building

7627 - River Town Construction, LLC	07-Neighborhood Greenways Project PH I- 7/21-7/30/22-App #3	BC 2021-157 10/14/2022	64,228.53
Account 54310 - Improvements Other Than Building Totals		Invoice 1 Transactions	\$64,228.53
Program 070000 - Main Totals		Invoice 10 Transactions	\$81,512.04
Department 07 - Engineering Totals		Invoice 10 Transactions	\$81,512.04



Board of Public Works Claim Register

Invoice Date Range 10/01/22 - 10/14/22

Department **09 - CFRD**

Program **090000 - Main**

Account **52110 - Office Supplies**

6530 - Office Depot, INC	09-Batteries	10/14/2022	14.12
6530 - Office Depot, INC	09-Lanyards	10/14/2022	49.78
6530 - Office Depot, INC	09-3-hole punches, Sanitizer, #10 Envelopes	10/14/2022	67.79
Account 52110 - Office Supplies Totals		Invoice 3	\$131.69
		Transactions	

Account **52420 - Other Supplies**

5819 - Synchrony Bank	09-Drink Dispenser for Events	10/14/2022	35.51
5819 - Synchrony Bank	09- AA Battery Charger	10/14/2022	12.99
Account 52420 - Other Supplies Totals		Invoice 2	\$48.50
		Transactions	

Account **53160 - Instruction**

3560 - First Financial Bank / Credit Cards	09-Indiana Consortium of State and Local Human Rights Training	10/14/2022	213.80
3560 - First Financial Bank / Credit Cards	09-IDA Publications on Homelessness and Public Safety	10/14/2022	40.00
3560 - First Financial Bank / Credit Cards	09-Charles Culp P.A.T.C. Verbal De-Escalation Training	10/14/2022	350.00
Account 53160 - Instruction Totals		Invoice 3	\$603.80
		Transactions	

Account **53960 - Grants**

203 - INDIANA UNIVERSITY	09-WTIU Conference on Aging Sponsorship	10/14/2022	375.00
Account 53960 - Grants Totals		Invoice 1	\$375.00
		Transactions	

Account **53990 - Other Services and Charges**

3560 - First Financial Bank / Credit Cards	09-Limited background check for Notary Public application	10/14/2022	16.32
Account 53990 - Other Services and Charges Totals		Invoice 1	\$16.32
		Transactions	



Board of Public Works Claim Register

Invoice Date Range 10/01/22 - 10/14/22

Program 090000 - Main Totals	Invoice 10	\$1,175.31
	Transactions	
Department 09 - CFRD Totals	Invoice 10	\$1,175.31
	Transactions	

Department **10 - Legal**

Program **100000 - Main**

Account **53120 - Special Legal Services**

8402 - Dentons Global Advisors	10 -legal services Gov relations public policy 7/1-7/31/22	10/14/2022	5,000.00
3560 - First Financial Bank / Credit Cards	10- doxpop -subscription 9/3-12/02/22, recorded document image	10/14/2022	103.95
608 - Krieg Devault, LLP	10- retainer agreement-Governmental Affairs- August 2022	10/14/2022	2,500.00
7855 - Veritext LLC	10- transcript services Annexation case 53C062203PL000509	10/14/2022	853.60
Account 53120 - Special Legal Services Totals		Invoice 4	\$8,457.55
		Transactions	
Program 100000 - Main Totals		Invoice 4	\$8,457.55
		Transactions	
Department 10 - Legal Totals		Invoice 4	\$8,457.55
		Transactions	

Department **11 - Mayor's Office**

Program **110000 - Main**

Account **53960 - Grants**

8292 - Bloomington Rotary Club	11 -BLUE Sponsorship-Btown rotary foundation	10/14/2022	1,250.00
205 - City Of Bloomington	11 -Sponsorship-Black Male Summit-Silver Level	10/14/2022	500.00
205 - City Of Bloomington	11 -Sponsorship-Black y Brown Arts festival- bronze level	10/14/2022	500.00
3560 - First Financial Bank / Credit Cards	11 -Nourish Bar-Meeting T&G catering- 9/28/22	10/14/2022	115.00
Account 53960 - Grants Totals		Invoice 4	\$2,365.00
		Transactions	

Account **53990 - Other Services and Charges**

3560 - First Financial Bank / Credit Cards	11 -Creative Market membership- digital needs	10/14/2022	24.50
--	--	------------	-------



Board of Public Works Claim Register

Invoice Date Range 10/01/22 - 10/14/22

3560 - First Financial Bank / Credit Cards	11 -Castr live streaming-9/5-10/5/22	10/14/2022	14.99
3560 - First Financial Bank / Credit Cards	11 -Creative Market platform- digital needs	10/14/2022	9.00
3560 - First Financial Bank / Credit Cards	11 -creative Market platform- digital needs	10/14/2022	6.00
3560 - First Financial Bank / Credit Cards	11 -creative Market platform- digital needs	10/14/2022	8.00
3560 - First Financial Bank / Credit Cards	11 -creative Market platform-membership, 300 downloads ds	10/14/2022	29.95
3560 - First Financial Bank / Credit Cards	11 -Facebook Post & Push-7/30-8/26/22	10/14/2022	63.84
3560 - First Financial Bank / Credit Cards	11 -digital asset management-9/10-10/10/22	10/14/2022	29.00
3560 - First Financial Bank / Credit Cards	11 -Lucid- Org charts for CoB-9/28-10/28/22	10/14/2022	9.95
3560 - First Financial Bank / Credit Cards	11 -rev transcription svc-21 minutes	10/14/2022	31.50
3560 - First Financial Bank / Credit Cards	11 -rev transcription svc-4 minutes	10/14/2022	6.00
3560 - First Financial Bank / Credit Cards	11 -Snedinblue-info distribution email platform	10/14/2022	32.00
3560 - First Financial Bank / Credit Cards	11 -vistaprint-letterhead and envelopes	10/14/2022	141.49
3560 - First Financial Bank / Credit Cards	11 -CoB note cards	10/14/2022	69.51
3560 - First Financial Bank / Credit Cards	11- Office Depot-credit sales tax refund- receipt 7/12/22	10/14/2022	(10.59)
4549 - Kroger Limited Partnership I	11 -Boards and commission event supplies	10/14/2022	19.07
4549 - Kroger Limited Partnership I	11 -Boards and commission event supplies REFUND TAX	10/14/2022	(1.25)
53442 - Paragon Micro, INC	11 -Wireless keyboard & mouse-JC	10/14/2022	80.99
53442 - Paragon Micro, INC	11 -IT software	10/14/2022	9.16
5819 - Synchrony Bank	11 -table cloths and Safety tool for OOTM	10/14/2022	94.63

Account 53990 - Other Services and Charges Totals	Invoice 20	\$667.74
	Transactions	
Program 110000 - Main Totals	Invoice 24	\$3,032.74
	Transactions	
Department 11 - Mayor's Office Totals	Invoice 24	\$3,032.74
	Transactions	



Board of Public Works Claim Register

Invoice Date Range 10/01/22 - 10/14/22

Department **12 - Human Resources**

Program **120000 - Main**

Account **53990 - Other Services and Charges**

3560 - First Financial Bank / Credit Cards	12-SHRM Membership Renewal-Scales	10/14/2022	229.00
3560 - First Financial Bank / Credit Cards	12-SCIHRA Conference \$50.00	10/14/2022	50.00
6099 - Safe Hiring Solutions	12-out of state background check	10/14/2022	101.40
7759 - Turning Point Initiatives (Center for Equity)	12-Anti Racism Training - follow ups, coaching, planning team	10/14/2022	18,527.00
6943 - Joseph W Ubben (Breakaway Performance Group, LLC)	12-Consultation Services	10/14/2022	475.00

Account 53990 - Other Services and Charges Totals	Invoice 5	\$19,382.40
	Transactions	
Program 120000 - Main Totals	Invoice 5	\$19,382.40
	Transactions	
Department 12 - Human Resources Totals	Invoice 5	\$19,382.40
	Transactions	

Department **13 - Planning**

Program **130000 - Main**

Account **53160 - Instruction**

4943 - Elizabeth M Rosenbarger	13-Travel Reimb & Registration NATCO- Boston-9/6-9/9/22	10/14/2022	1,100.00
--------------------------------	--	------------	----------

Account 53160 - Instruction Totals	Invoice 1	\$1,100.00
	Transactions	

Account **53230 - Travel**

4943 - Elizabeth M Rosenbarger	13-Travel Reimb & Registration NATCO- Boston-9/6-9/9/22	10/14/2022	1,840.57
--------------------------------	--	------------	----------

Account 53230 - Travel Totals	Invoice 1	\$1,840.57
	Transactions	

Account **53990 - Other Services and Charges**

7397 - Data Mgmt Internationale, INC (Smooth Solutions)	13 - Converting misc. files-inv date 8/25/22	10/14/2022	3,870.42
7397 - Data Mgmt Internationale, INC (Smooth Solutions)	13 - Converting misc. files & P&T Scanning archived files	10/14/2022	5,576.29



Board of Public Works Claim Register

Invoice Date Range 10/01/22 - 10/14/22

Account 53990 - Other Services and Charges Totals		Invoice 2	\$9,446.71
		Transactions	
Program 130000 - Main Totals		Invoice 4	\$12,387.28
		Transactions	
Program 132000 - MPO			
Account 53160 - Instruction			
3560 - First Financial Bank / Credit Cards	13-MPO Conference Registration (for Ryan Clemens)_10/4 thru 10/6	10/14/2022	150.00
Account 53160 - Instruction Totals		Invoice 1	\$150.00
		Transactions	
Program 132000 - MPO Totals		Invoice 1	\$150.00
		Transactions	
Department 13 - Planning Totals		Invoice 5	\$12,537.28
		Transactions	
Department 19 - Facilities Maintenance			
Program 190000 - Main			
Account 52210 - Institutional Supplies			
5819 - Synchrony Bank	19 - (4) Hard HatS	10/14/2022	38.24
Account 52210 - Institutional Supplies Totals		Invoice 1	\$38.24
		Transactions	
Account 52310 - Building Materials and Supplies			
394 - Kleindorfer Hardware & Variety	19-Dawn soap and vinegar for Facilities	10/14/2022	22.48
5819 - Synchrony Bank	19 - (2) Sloan mixing valve	10/14/2022	73.46
Account 52310 - Building Materials and Supplies Totals		Invoice 2	\$95.94
		Transactions	
Account 52420 - Other Supplies			
5819 - Synchrony Bank	19 - Document display system	10/14/2022	82.35
Account 52420 - Other Supplies Totals		Invoice 1	\$82.35
		Transactions	
Account 52430 - Uniforms and Tools			
19171 - Aramark Uniform & Career Apparel Group, INC	19- Uniforms for Facility Employees-9/15/22	10/14/2022	30.84



Board of Public Works Claim Register

Invoice Date Range 10/01/22 - 10/14/22

19171 - Aramark Uniform & Career Apparel Group, INC	19- Uniforms for Facility Employees for 9/22/2022		10/14/2022	30.84
	Account 52430 - Uniforms and Tools Totals	Invoice 2		<u>\$61.68</u>
		Transactions		
Account 53140 - Exterminator Services				
51538 - Economy Termite & Pest Control, INC	19-Exterminator Services for Councill office- 9/16/22	BC 2021-108	10/14/2022	75.00
	Account 53140 - Exterminator Services Totals	Invoice 1		<u>\$75.00</u>
		Transactions		
Account 53610 - Building Repairs				
321 - Harrell Fish, INC (HFI)	19-SA Repair of Air Unit in HR	BC 2021-111	10/14/2022	446.28
321 - Harrell Fish, INC (HFI)	19-SA Replace and Install new blower and motor in AC Unit in ITS	BC 2021-111	10/14/2022	1,183.92
392 - Koorsen Fire & Security, INC	19-SA Annual Fire Extinguisher Inspection & Exchanges	BC 2022-16	10/14/2022	538.22
6688 - SSW Enterprises, LLC (Office Pride)	19-Cleaning Services at Animal Care & Control for September 2022	BC 2021-126	10/14/2022	1,391.26
6688 - SSW Enterprises, LLC (Office Pride)	19- Cleaning Services at City Hall for September 2022	BC 2021-126	10/14/2022	13,113.66
6688 - SSW Enterprises, LLC (Office Pride)	19- Cleaning Services at Fleet for September 2022	BC 2021-126	10/14/2022	1,041.60
6688 - SSW Enterprises, LLC (Office Pride)	19- Cleaning Services at Sanitation Garage for September 2022	BC 2021-126	10/14/2022	805.29
6688 - SSW Enterprises, LLC (Office Pride)	19- Cleaning Services-Street & Traffic for September 2022	BC 2021-126	10/14/2022	1,598.31
3980 - Robert Wyatt Thrasher III (Thrasher Landscape, INC)	19-SA Landscaping Clean-up & Mulch @ 4th St Garage	BC 2022-59	10/14/2022	1,412.92
	Account 53610 - Building Repairs Totals	Invoice 9		<u>\$21,531.46</u>
		Transactions		
Account 53990 - Other Services and Charges				
392 - Koorsen Fire & Security, INC	19-SA Annual Monitoring-Fire Alarm/Fire Alarm Call/Net-9/22-8/23	BC 2022-16	10/14/2022	600.00
60 - Monroe County Solid Waste Management District	19-Disposal of batteries and fluorescent bulbs		10/14/2022	125.26
	Account 53990 - Other Services and Charges Totals	Invoice 2		<u>\$725.26</u>
		Transactions		
	Program 190000 - Main Totals	Invoice 18		<u>\$22,609.93</u>
		Transactions		
	Department 19 - Facilities Maintenance Totals	Invoice 18		<u>\$22,609.93</u>
		Transactions		



Board of Public Works Claim Register

Invoice Date Range 10/01/22 - 10/14/22

Department **28 - ITS**

Program **280000 - Main**

Account **53230 - Travel**

7929 - Desiree King	28-Reimb-Admin Prof Conf-FL-9/10-9/14/22	10/14/2022	663.32
	Account 53230 - Travel Totals	Invoice 1	\$663.32
		Transactions	

Account **53640 - Hardware and Software Maintenance**

3989 - Ricoh USA, INC	28-Copier maintenance Main bill-8/17-9/16/22	10/14/2022	2,162.20
3989 - Ricoh USA, INC	28-Copier maintenance Secondary bill-8/17-9/16/22	10/14/2022	161.76
8750 - Service Express, INC	28 - City Hall and BPD server maintenance 10/1/--12/31/2022	10/14/2022	1,056.00
	Account 53640 - Hardware and Software Maintenance Totals	Invoice 3	\$3,379.96
		Transactions	

Account **53910 - Dues and Subscriptions**

3560 - First Financial Bank / Credit Cards	28 - Bluesky Zoom timer - September 2022	10/14/2022	89.95
3560 - First Financial Bank / Credit Cards	28 - Google APIs - September 1, 2022	10/14/2022	159.77
3560 - First Financial Bank / Credit Cards	28 - Google domain helpingbloomingtonmonroe.org	10/14/2022	12.00
3560 - First Financial Bank / Credit Cards	28 - Submittable monthly subscription 9/27-10/27/2022	10/14/2022	119.00
3560 - First Financial Bank / Credit Cards	28 - Zoom 500 parti., 1000 webinar, 500GB cloud - 9/20-10/19/22	10/14/2022	430.00
7344 - Periodic INC	28 - Resources and bookables overage charges - September 2022	10/14/2022	137.00
	Account 53910 - Dues and Subscriptions Totals	Invoice 6	\$947.72
		Transactions	

Account **53960 - Grants**

8332 - Alexandra's Food Drive INC (Alexandra's Army)	28 - 2022 Digital Equity Grants recipient	10/14/2022	4,000.00
41 - Area 10 Agency On Aging	28 - 2022 Digital Equity Grants recipient	10/14/2022	6,000.00
6590 - Artisan Alley, LTD	28 - 2022 Digital Equity Grants recipient	10/14/2022	4,100.00



Board of Public Works Claim Register

Invoice Date Range 10/01/22 - 10/14/22

7033 - Courage to Change Sober Living, INC	28 - 2022 Digital Equity Grants recipient	10/14/2022	5,500.00
7645 - Farmer House Museum INC	28 - 2022 Digital Equity Grants recipient	10/14/2022	4,000.00
8081 - Hotels for Hope INC (Hotels For Homeless)	28 - 2022 Digital Equity Grants recipient	10/14/2022	5,500.00
64 - Monroe County Public Library	28 - 2022 Digital Equity Grants recipient	10/14/2022	3,800.00
1021 - My Sister's Closet Of Monroe County, INC	28 - 2022 Digital Equity Grants recipient	10/14/2022	5,700.00
18311 - New Leaf/New Life, INC	28 - 2022 Digital Equity Grants recipient	10/14/2022	4,000.00
8389 - Robin & Trishas House INC	28 - 2022 Digital Equity Grants recipient	10/14/2022	3,300.00
230 - South Central Community Action Program INC	28 - 2022 Digital Equity Grants recipient	10/14/2022	4,100.00
Account 53960 - Grants Totals		Invoice 11 Transactions	\$50,000.00
Account 54420 - Purchase of Equipment			
53442 - Paragon Micro, INC	28 - Dell Precision laptop - HAND- C. Finley	10/14/2022	2,048.97
53442 - Paragon Micro, INC	28 - Logitech C920e webcam - ITS stock	10/14/2022	64.99
5819 - Synchrony Bank	28 - TP-Link external wifi unit - Walid Sib0	10/14/2022	49.99
Account 54420 - Purchase of Equipment Totals		Invoice 3 Transactions	\$2,163.95
Program 280000 - Main Totals		Invoice 24 Transactions	\$57,154.95
Department 28 - ITS Totals		Invoice 24 Transactions	\$57,154.95
Fund 101 - General Fund (S0101) Totals		Invoice 170 Transactions	\$387,095.79
Fund 103 - Restricted Donations(ord 05-17)			
Department 06 - Controller's Office			
Program 400101 - Animal Medical Services			
Account 53130 - Medical			
54639 - Shake Veterinary Services, INC (Town & Country Vet	01-Diagnostics, Surgeries & Other Vet Services	10/14/2022	178.70



Board of Public Works Claim Register

Invoice Date Range 10/01/22 - 10/14/22

54639 - Shake Veterinary Services, INC (Town & Country Vet	01-Surgeries & Diagnostics	10/14/2022	985.80
	Account 53130 - Medical Totals	Invoice 2	<u>\$1,164.50</u>
		Transactions	
	Program 400101 - Animal Medical Services Totals	Invoice 2	<u>\$1,164.50</u>
		Transactions	
	Department 06 - Controller's Office Totals	Invoice 2	<u>\$1,164.50</u>
		Transactions	
	Fund 103 - Restricted Donations(ord 05-17) Totals	Invoice 2	<u>\$1,164.50</u>
		Transactions	
Fund 176 - ARPA Local Fiscal Recvry (S9512)			
Department 04 - Economic & Sustainable Dev			
Program G21005 - ARPA COVID Local Fiscal Recovery			
Account 53960 - Grants			
8398 - Arthur Luhur	04: BGHIP Rebate - Arthur Luhur-1307 S Valley Forge Road	10/14/2022	1,000.00
421 - Centerstone Of Indiana, INC	04- Brighton Btown DPW labor funding for Aug 2022	BC 2022-57 10/14/2022	16,352.26
	Account 53960 - Grants Totals	Invoice 2	<u>\$17,352.26</u>
		Transactions	
Account 53990 - Other Services and Charges			
6378 - ANN-KRISS, LLC	04 -Waldron-finish stairwell repairs, painting, finish deck sys	10/14/2022	15,048.09
321 - Harrell Fish, INC (HFI)	04: Waldron Condensing Units & AC Coils	10/14/2022	11,500.00
8004 - Trahan Architects APAC	04: Arts Feasibility Study (2nd 50%)-Site visits-May-August	10/14/2022	4,950.00
	Account 53990 - Other Services and Charges Totals	Invoice 3	<u>\$31,498.09</u>
		Transactions	
	Program G21005 - ARPA COVID Local Fiscal Recovery Totals	Invoice 5	<u>\$48,850.35</u>
		Transactions	
	Department 04 - Economic & Sustainable Dev Totals	Invoice 5	<u>\$48,850.35</u>
		Transactions	
Department 07 - Engineering			
Program G21005 - ARPA COVID Local Fiscal Recovery			
Account 54310 - Improvements Other Than Building			



Board of Public Works Claim Register

Invoice Date Range 10/01/22 - 10/14/22

7627 - River Town Construction, LLC

07-Neighborhood Greenways Project PH I- 7/21-7/30/22-App #3	BC 2021-157	10/14/2022	55,904.98
Account 54310 - Improvements Other Than Building Totals	Invoice 1		<u>\$55,904.98</u>
	Transactions		
Program G21005 - ARPA COVID Local Fiscal Recovery Totals	Invoice 1		<u>\$55,904.98</u>
	Transactions		
Department 07 - Engineering Totals	Invoice 1		<u>\$55,904.98</u>
	Transactions		

Department **20 - Street**

Program **G21005 - ARPA COVID Local Fiscal Recovery**

Account **52330 - Street , Alley, and Sewer Material**

19278 - Milestone Contractors, LP	20-Asphalt for Paving & Patching-13th St	BC 2021-119	10/14/2022	16,768.97
19278 - Milestone Contractors, LP	20-Asphalt for Paving & Patching-12th St/Summit	BC 2021-119	10/14/2022	18,231.03
Account 52330 - Street , Alley, and Sewer Material Totals	Invoice 2		<u>\$35,000.00</u>	
	Transactions			
Program G21005 - ARPA COVID Local Fiscal Recovery Totals	Invoice 2		<u>\$35,000.00</u>	
	Transactions			
Department 20 - Street Totals	Invoice 2		<u>\$35,000.00</u>	
	Transactions			
Fund 176 - ARPA Local Fiscal Recvry (S9512) Totals	Invoice 8		<u>\$139,755.33</u>	
	Transactions			

Fund **312 - Community Services**

Department **09 - CFRD**

Program **090014 - Latino Programs**

Account **52420 - Other Supplies**

4549 - Kroger Limited Partnership I	09-Snacks for Fiesta del Otono volunteers		10/14/2022	36.83
Account 52420 - Other Supplies Totals	Invoice 1		<u>\$36.83</u>	
	Transactions			
Program 090014 - Latino Programs Totals	Invoice 1		<u>\$36.83</u>	
	Transactions			

Program **090016 - Com Serv - Safe & Civil**

Account **52420 - Other Supplies**



Board of Public Works Claim Register

Invoice Date Range 10/01/22 - 10/14/22

3560 - First Financial Bank / Credit Cards	09-Pizza for Black Male Summit - Domino's	10/14/2022	234.70
3560 - First Financial Bank / Credit Cards	09-Pizza for Black Male Summit - Domino's	10/14/2022	242.24
	Account 52420 - Other Supplies Totals	Invoice 2	<hr/> \$476.94
		Transactions	
Account 53990 - Other Services and Charges			
3560 - First Financial Bank / Credit Cards	09-Safe and Civil City Jotform-9/18-10/18/22	10/14/2022	19.00
	Account 53990 - Other Services and Charges Totals	Invoice 1	<hr/> \$19.00
		Transactions	
	Program 090016 - Com Serv - Safe & Civil Totals	Invoice 3	<hr/> \$495.94
		Transactions	
Program 090020 - Commission on Aging			
Account 53990 - Other Services and Charges			
203 - INDIANA UNIVERSITY	09-WTIU Conference on Aging Sponsorship	10/14/2022	375.00
	Account 53990 - Other Services and Charges Totals	Invoice 1	<hr/> \$375.00
		Transactions	
	Program 090020 - Commission on Aging Totals	Invoice 1	<hr/> \$375.00
		Transactions	
	Department 09 - CFRD Totals	Invoice 5	<hr/> \$907.77
		Transactions	
	Fund 312 - Community Services Totals	Invoice 5	<hr/> \$907.77
		Transactions	
Fund 401 - Non-Reverting Telecom (S1146)			
Department 25 - Telecommunications			
Program 254000 - Infrastructure			
Account 53640 - Hardware and Software Maintenance			
902 - Indiana Underground Plant Protection Service, INC	25 - Indiana 811 line locate fees - August 2022	10/14/2022	152.95
	Account 53640 - Hardware and Software Maintenance Totals	Invoice 1	<hr/> \$152.95
		Transactions	
	Program 254000 - Infrastructure Totals	Invoice 1	<hr/> \$152.95
		Transactions	
Program 256000 - Services			



Board of Public Works Claim Register

Invoice Date Range 10/01/22 - 10/14/22

Account **53150 - Communications Contract**

203 - INDIANA UNIVERSITY

25 - Dark Fiber - September 2022

10/14/2022

65.00

Account **53150 - Communications Contract** Totals

Invoice 1

\$65.00

Transactions

Program **256000 - Services** Totals

Invoice 1

\$65.00

Transactions

Department **25 - Telecommunications** Totals

Invoice 2

\$217.95

Transactions

Fund **401 - Non-Reverting Telecom (S1146)** Totals

Invoice 2

\$217.95

Transactions

Fund **450 - Local Road and Street(S0706)**

Department **20 - Street**

Program **200000 - Main**

Account **53520 - Street Lights / Traffic Signals**

223 - Duke Energy	02-Rogers Rd Sidepath-elec chgs 8/17-9/16/22	BC 2019-99	10/05/2022	11.11
223 - Duke Energy	02-Illinois St/Illinois Ct-elec chgs 8/23-9/21/22	BC 2021-12	10/05/2022	7.79
223 - Duke Energy	02-W. 12th & N. Lindberg -elec. chgs 8/23-9/21/22	BC 2021-11	10/05/2022	4.24
223 - Duke Energy	02-3rd/5th/Adams traffic signal-elec chgs 8/25-9/23/22		10/05/2022	57.51
223 - Duke Energy	02-N. Blair Ave-walkway elec chgs-8/23-9/21/22	BC 2021-76	10/05/2022	3.99
223 - Duke Energy	02-6th St (Fairview to Elm)-elec chgs 8/25-9/23/22	BC 2021-59	10/05/2022	29.42
223 - Duke Energy	02-W 11th (Fairview & Fountain)-elec chgs 8/23-9/21/22	BC 2021-108	10/05/2022	50.85
223 - Duke Energy	02-Gray/Lemon/Fountain-elec chgs-8/23-8/21/22	BC 2021-143	10/05/2022	24.75

Account **53520 - Street Lights / Traffic Signals** Totals

Invoice 8

\$189.66

Transactions

Account **54310 - Improvements Other Than Building**

17 - Bynum Fanyo & Associates, INC	02 & 20-PE-6th-Morton Alley Reno Design/Amend-9/16/22	BC 2022-19	10/14/2022	1,908.00
18844 - First Financial Bank, N.A.	20-IN Sign/BarricadeEscrow-2022 Pavement Marking Contract-App #1	BC 2022-54	10/14/2022	7,013.92



Board of Public Works Claim Register

Invoice Date Range 10/01/22 - 10/14/22

Account 54310 - Improvements Other Than Building Totals	Invoice 2	\$8,921.92
	Transactions	
Program 200000 - Main Totals	Invoice 10	\$9,111.58
	Transactions	
Department 20 - Street Totals	Invoice 10	\$9,111.58
	Transactions	
Fund 450 - Local Road and Street(S0706) Totals	Invoice 10	\$9,111.58
	Transactions	

Fund 451 - Motor Vehicle Highway(S0708)

Department 20 - Street

Program 200000 - Main

Account 52420 - Other Supplies

5819 - Synchrony Bank	20-Arborists' Certification Study Guide (McCoy)	10/14/2022	144.99
	Account 52420 - Other Supplies Totals	Invoice 1	\$144.99
		Transactions	

Account 53520 - Street Lights / Traffic Signals

18844 - First Financial Bank, N.A.	20-TAPCO-Escrow-Traffic Signal Inspections BC 2022-066-App 1	10/14/2022	1,653.59
4506 - TAPCO (Traffic and Parking Control Co INC)	20-Traffic Signal Inspections BC 2022-066-App 1	BC 2022-066 10/14/2022	31,418.17
	Account 53520 - Street Lights / Traffic Signals Totals	Invoice 2	\$33,071.76
		Transactions	

Account 53920 - Laundry and Other Sanitation Services

19171 - Aramark Uniform & Career Apparel Group, INC	20-Uniform service-9/14/22	10/14/2022	9.87
19171 - Aramark Uniform & Career Apparel Group, INC	20-Mat Services for Street Department for 9/14/2022	10/14/2022	34.28
19171 - Aramark Uniform & Career Apparel Group, INC	20-Uniform Service-8/31/22	10/14/2022	6.41
19171 - Aramark Uniform & Career Apparel Group, INC	20-Mat Services for Street Department-9/21/22	10/14/2022	34.28
	Account 53920 - Laundry and Other Sanitation Services Totals	Invoice 4	\$84.84
		Transactions	
	Program 200000 - Main Totals	Invoice 7	\$33,301.59
		Transactions	
	Department 20 - Street Totals	Invoice 7	\$33,301.59
		Transactions	



Board of Public Works Claim Register

Invoice Date Range 10/01/22 - 10/14/22

				Invoice 7	\$33,301.59
				Transactions	
Fund 451 - Motor Vehicle Highway(S0708) Totals					
Fund 452 - Parking Facilities(S9502)					
Department 26 - Parking					
Program 260000 - Main					
Account 52310 - Building Materials and Supplies					
394 - Kleindorfer Hardware & Variety	26-Padlocks for Parking Facilities		10/14/2022		151.29
392 - Koorsen Fire & Security, INC	26-Fire Extinguisher Inspection & Replacements		10/14/2022		1,148.65
	Account 52310 - Building Materials and Supplies Totals			Invoice 2	\$1,299.94
				Transactions	
Account 52340 - Other Repairs and Maintenance					
4394 - Richardson Enterprises of Blgtn,LLC (FastSigns)	26-Windmaster Signs for Parking Garage		10/14/2022		231.19
4394 - Richardson Enterprises of Blgtn,LLC (FastSigns)	26-Restroom Signs, Braille Signs for Parking Garage		10/14/2022		429.40
4394 - Richardson Enterprises of Blgtn,LLC (FastSigns)	26-Windmaster Signs		10/14/2022		154.13
4394 - Richardson Enterprises of Blgtn,LLC (FastSigns)	26-Windmaster Signs for Parking Garage		10/14/2022		77.06
4394 - Richardson Enterprises of Blgtn,LLC (FastSigns)	26-ticket entry spitter decals, wind sign inserts		10/14/2022		258.32
	Account 52340 - Other Repairs and Maintenance Totals			Invoice 5	\$1,150.10
				Transactions	
Account 53610 - Building Repairs					
6378 - ANN-KRISS, LLC	26-SVS-Repair Electrical at Morton & 4th St Garages		10/14/2022		338.00
32 - Cassady Electrical Contractors, INC	26-Morton St Garage-Cut Wiring and Cut Junction Box	BC 2021-103	10/14/2022		170.77
6197 - CE Solutions, INC	26-SVS-Walnut Street Repair Project paid thru August 15	BC 2021-105	10/14/2022		6,120.05
1537 - Indiana Door & Hardware Specialties, INC	26- Service call and repair on RR Door	BC 2021-142	10/14/2022		135.00
392 - Koorsen Fire & Security, INC	26-SVS-SA Fire Alarm Repair	BC 2022-16	10/14/2022		272.95
	Account 53610 - Building Repairs Totals			Invoice 5	\$7,036.77
				Transactions	



Board of Public Works Claim Register

Invoice Date Range 10/01/22 - 10/14/22

Account 53630 - Machinery and Equipment Repairs

3397 - Evens Time, INC	26- 2022 SA Repair Morton St Garage Display-BC 2021-123 9/6/22	10/14/2022	801.32
3397 - Evens Time, INC	26- SVS-Repair 4th Street Garage gate arm- 9/8/22	BC 2021-123 10/14/2022	632.99
Account 53630 - Machinery and Equipment Repairs Totals			Invoice 2 Transactions \$1,434.31

Account 53640 - Hardware and Software Maintenance

3397 - Evens Time, INC	26-SA setup Macro for 4th street garage- 12/9/21	BC 2021-123 10/14/2022	210.00
3397 - Evens Time, INC	26-SA Repair Broken gate arm 4th St Garage- 7/1/22	BC 2021-123 10/14/2022	352.99
3397 - Evens Time, INC	26-SA Repair broken gate arm Walnut St Garage-5/31/22	BC 2021-123 10/14/2022	422.99
3397 - Evens Time, INC	26-SA Repair Broken note acceptor-3/2/22	BC 2021-123 10/14/2022	500.99
3397 - Evens Time, INC	26-SA Repair City Hall validator-12/9/21	BC 2021-123 10/14/2022	670.00
Account 53640 - Hardware and Software Maintenance Totals			Invoice 5 Transactions \$2,156.97

Account 53650 - Other Repairs

7453 - Browning Chapman, LLC	26-SVS Contract for 2022 Walnut Street Garage Repair Project	BC 2022-35 10/14/2022	149,900.00
Account 53650 - Other Repairs Totals			Invoice 1 Transactions \$149,900.00

Account 53840 - Lease Payments

512 - 7th & Walnut , LLC	26-Walnut St Garage- November 2022 garage rent	10/14/2022	17,824.79
3887 - Mercury Development Group, LLC	26-Morton St Garage-November 2022 garage rent	10/14/2022	38,035.85
Account 53840 - Lease Payments Totals			Invoice 2 Transactions \$55,860.64

Account 53990 - Other Services and Charges

6330 - Marshall Security LLC	26-SVS Contract for Patrol of Garages for Aug 2022	BC 2022-011 10/14/2022	3,968.00
6330 - Marshall Security LLC	26-SVS Contract for Patrol of Garages for September 2022	BC 2022-011 10/14/2022	3,840.00
Account 53990 - Other Services and Charges Totals			Invoice 2 Transactions \$7,808.00



Board of Public Works Claim Register

Invoice Date Range 10/01/22 - 10/14/22

Program 260000 - Main Totals	Invoice 24	\$226,646.73
	Transactions	
Department 26 - Parking Totals	Invoice 24	\$226,646.73
	Transactions	
Fund 452 - Parking Facilities(S9502) Totals	Invoice 24	\$226,646.73
	Transactions	

Fund **454 - Alternative Transport(S6301)**

Department **05 - Common Council**

Program **050000 - Main**

Account **54310 - Improvements Other Than Building**

10 - Bledsoe Riggert Cooper & James INC	07-Dunn St. Sidewalk (15th-16th)-inv date 8/31/22	BC 2021-37	10/14/2022	735.00
	Account 54310 - Improvements Other Than Building Totals		Invoice 1	\$735.00
			Transactions	
	Program 050000 - Main Totals		Invoice 1	\$735.00
			Transactions	
	Department 05 - Common Council Totals		Invoice 1	\$735.00
			Transactions	

Department **07 - Engineering**

Program **070000 - Main**

Account **54310 - Improvements Other Than Building**

18844 - First Financial Bank, N.A.	07-Neighborhood Greenways PH I-App 3- 7/21-7/30/22		10/14/2022	10,992.08
	Account 54310 - Improvements Other Than Building Totals		Invoice 1	\$10,992.08
			Transactions	
	Program 070000 - Main Totals		Invoice 1	\$10,992.08
			Transactions	
	Department 07 - Engineering Totals		Invoice 1	\$10,992.08
			Transactions	

Department **13 - Planning**

Program **130000 - Main**

Account **54310 - Improvements Other Than Building**

7059 - Eagle Ridge Civil Engineering Services, LLC	13-Neighborhood Greenways-inv date 9/30/22	BC 2020-106	10/14/2022	12,806.60
--	---	-------------	------------	-----------



Board of Public Works Claim Register

Invoice Date Range 10/01/22 - 10/14/22

Account 54310 - Improvements Other Than Building Totals	Invoice 1	\$12,806.60
	Transactions	
Program 130000 - Main Totals	Invoice 1	\$12,806.60
	Transactions	
Department 13 - Planning Totals	Invoice 1	\$12,806.60
	Transactions	
Fund 454 - Alternative Transport(\$6301) Totals	Invoice 3	\$24,533.68
	Transactions	

Fund 455 - Parking Meter Fund(\$2141)

Department 26 - Parking

Program 260000 - Main

Account 52340 - Other Repairs and Maintenance

409 - Black Lumber Co. INC	26-lumber to build a work bench for meter repair	10/14/2022	29.99
4264 - IPS Group, INC	26-Collection Cards for Brandon Hedrick	10/14/2022	71.18
4264 - IPS Group, INC	26-out of warranty clock repairs (3)	10/14/2022	2,423.96

Account 52340 - Other Repairs and Maintenance Totals	Invoice 3	\$2,525.13
	Transactions	

Account 52420 - Other Supplies

4264 - IPS Group, INC	26-4G meter clock upgrade on 1154 clocks (177)	10/14/2022	32,744.00
4264 - IPS Group, INC	26-4G meter clock upgrade on 1154 clocks	10/14/2022	3,446.15
394 - Kleindorfer Hardware & Variety	26-misc parking supplies-wedge door stops	10/14/2022	13.38
394 - Kleindorfer Hardware & Variety	26-misc parking supplies-glue, putty knife, caulk	10/14/2022	23.56
5819 - Synchrony Bank	26-office supplies-sharpies, post it notes, white out, pen refill	10/14/2022	95.51
5819 - Synchrony Bank	26-office supplies-carpet cleaner, sticky notes, earbuds	10/14/2022	86.46

Account 52420 - Other Supplies Totals	Invoice 6	\$36,409.06
	Transactions	

Account 53240 - Freight / Other

4264 - IPS Group, INC	26-4G meter clock upgrade on 1154 clocks (177)	10/14/2022	1.00
-----------------------	--	------------	------



Board of Public Works Claim Register

Invoice Date Range 10/01/22 - 10/14/22

4264 - IPS Group, INC

26-4G meter clock upgrade on 1154 clocks 10/14/2022 1.00

Account **53240 - Freight / Other** Totals Invoice 2 \$2.00

Transactions

Program **260000 - Main** Totals Invoice 11 \$38,936.19

Transactions

Department **26 - Parking** Totals Invoice 11 \$38,936.19

Transactions

Fund **455 - Parking Meter Fund(S2141)** Totals Invoice 11 \$38,936.19

Transactions

Fund 456 - MVH Restricted

Department **20 - Street**

Program **200000 - Main**

Account **52330 - Street , Alley, and Sewer Material**

3560 - First Financial Bank / Credit Cards 20-Lowes-Red Duals brick for Kirkwood sidewalk repair 10/14/2022 11.56

19278 - Milestone Contractors, LP 20-Asphalt for Paving & Patching-12th St/Summit BC 2021-119 10/14/2022 12,929.52

Account **52330 - Street , Alley, and Sewer Material** Totals Invoice 2 \$12,941.08

Transactions

Account **52340 - Other Repairs and Maintenance**

19681 - Southeastern Equipment Co, INC 20-Teeth for Milling Machine 10/14/2022 598.00

Account **52340 - Other Repairs and Maintenance** Totals Invoice 1 \$598.00

Transactions

Account **52420 - Other Supplies**

409 - Black Lumber Co. INC 20-Kirkwood SW Repair-utility blades, adhesive, wire brush 10/14/2022 48.78

Account **52420 - Other Supplies** Totals Invoice 1 \$48.78

Transactions

Program **200000 - Main** Totals Invoice 4 \$13,587.86

Transactions

Department **20 - Street** Totals Invoice 4 \$13,587.86

Transactions

Fund **456 - MVH Restricted** Totals Invoice 4 \$13,587.86

Transactions

Fund 600 - Cumulative Cap Imprv(CIG)(S2379)



Board of Public Works Claim Register

Invoice Date Range 10/01/22 - 10/14/22

Department **02 - Public Works**

Program **020000 - Main**

Account **52330 - Street , Alley, and Sewer Material**

334 - Irving Materials, INC	20-Mill Stone Way & Ct-Concrete for sidewalks & ADA ramps	BC 2022-010	10/14/2022	620.00
334 - Irving Materials, INC	20-3824 S. Mill Stone Ct-Concrete for sidewalks & ADA ramps	BC 2022-010	10/14/2022	500.00
Account 52330 - Street , Alley, and Sewer Material Totals			Invoice 2	<u>\$1,120.00</u>
			Transactions	
Program 020000 - Main Totals			Invoice 2	<u>\$1,120.00</u>
			Transactions	
Department 02 - Public Works Totals			Invoice 2	<u>\$1,120.00</u>
			Transactions	
Fund 600 - Cumulative Cap Imprv(CIG)(S2379) Totals			Invoice 2	<u>\$1,120.00</u>
			Transactions	

Fund **601 - Cumulative Capital Devlp(S2391)**

Department **02 - Public Works**

Program **020000 - Main**

Account **52330 - Street , Alley, and Sewer Material**

19278 - Milestone Contractors, LP	20-Asphalt for Paving & Patching-13th St	BC 2021-119	10/14/2022	104.03
19278 - Milestone Contractors, LP	20-Asphalt for Paving & Patching-12th St/Summit	BC 2021-119	10/14/2022	294.98
Account 52330 - Street , Alley, and Sewer Material Totals			Invoice 2	<u>\$399.01</u>
			Transactions	

Account **52420 - Other Supplies**

409 - Black Lumber Co. INC	20-Misc Supplies for sign crew-staple gun, staples		10/14/2022	23.57
409 - Black Lumber Co. INC	20-cable for TV install-VanDeventer's Office		10/14/2022	20.98
409 - Black Lumber Co. INC	20-hardware for TV installation in VanDeventer's Office		10/14/2022	5.67
409 - Black Lumber Co. INC	20-Misc Supplies for sign crews-utility blades		10/14/2022	12.99
394 - Kleindorfer Hardware & Variety	20-(3) #7 drill bits for crews		10/14/2022	9.45



Board of Public Works Claim Register

Invoice Date Range 10/01/22 - 10/14/22

394 - Kleindorfer Hardware & Variety	20-Misc Supplies for crews-drill bit,	10/14/2022	7.35
394 - Kleindorfer Hardware & Variety	20-Misc Supplies for crews-cutting blades	10/14/2022	17.98
Account 52420 - Other Supplies Totals		Invoice 7	<u>\$97.99</u>
		Transactions	
Account 54510 - Other Capital Outlays			
4702 - Indiana Sign & Barricade, INC	20-2022 Pavement Marking Contract-App #1 BC 2022-054	10/14/2022	133,264.48
Account 54510 - Other Capital Outlays Totals		Invoice 1	<u>\$133,264.48</u>
		Transactions	
Program 020000 - Main Totals		Invoice 10	<u>\$133,761.48</u>
		Transactions	
Department 02 - Public Works Totals		Invoice 10	<u>\$133,761.48</u>
		Transactions	
Department 07 - Engineering			
Program 070000 - Main			
Account 54310 - Improvements Other Than Building			
10 - Bledsoe Riggert Cooper & James INC	07-Property pins for 1604 W. 17th Street	10/14/2022	1,750.00
Account 54310 - Improvements Other Than Building Totals		Invoice 1	<u>\$1,750.00</u>
		Transactions	
Program 070000 - Main Totals		Invoice 1	<u>\$1,750.00</u>
		Transactions	
Department 07 - Engineering Totals		Invoice 1	<u>\$1,750.00</u>
		Transactions	
Fund 601 - Cumulative Capital Devlp(S2391) Totals		Invoice 11	<u>\$135,511.48</u>
		Transactions	
Fund 730 - Solid Waste (S6401)			
Department 16 - Sanitation			
Program 160000 - Main			
Account 53140 - Exterminator Services			
51538 - Economy Termite & Pest Control, INC	16- Exterminator Services @ Sanitation - 9/14/2022	BC 2021-108 10/14/2022	125.00
Account 53140 - Exterminator Services Totals		Invoice 1	<u>\$125.00</u>
		Transactions	



Board of Public Works Claim Register

Invoice Date Range 10/01/22 - 10/14/22

Account 53610 - Building Repairs

321 - Harrell Fish, INC (HFI)	19-SA Semi-Annual BFP Testing at Sanitation- BC 2021-116 9/6/22	10/14/2022	225.00
Account 53610 - Building Repairs Totals		Invoice 1	<hr/> \$225.00
		Transactions	

Account 53920 - Laundry and Other Sanitation Services

19171 - Aramark Uniform & Career Apparel Group, INC	16-uniform rental (minus payroll ded)- 9/14/2022	10/14/2022	4.62
19171 - Aramark Uniform & Career Apparel Group, INC	16-uniform rental (minus payroll ded)- 9/21/2022	10/14/2022	4.62
19171 - Aramark Uniform & Career Apparel Group, INC	16-Mat Services - 9-21-2022	10/14/2022	23.26
Account 53920 - Laundry and Other Sanitation Services Totals		Invoice 3	<hr/> \$32.50
		Transactions	

Account 53950 - Landfill

52226 - Hoosier Transfer Station-3140	16-trash disposal fees-9/1-9/15/22	10/14/2022	16,253.82
52226 - Hoosier Transfer Station-3140	16-recycling fees-9/1-9/15/22	10/14/2022	2,798.41
Account 53950 - Landfill Totals		Invoice 2	<hr/> \$19,052.23
		Transactions	

Account 53990 - Other Services and Charges

392 - Koorsen Fire & Security, INC	16- Inspection of Fire Extinguishers for trucks - 7	BC 2022-016 10/14/2022	1,869.00
Account 53990 - Other Services and Charges Totals		Invoice 1	<hr/> \$1,869.00
		Transactions	
Program 160000 - Main Totals		Invoice 8	<hr/> \$21,303.73
		Transactions	
Department 16 - Sanitation Totals		Invoice 8	<hr/> \$21,303.73
		Transactions	
Fund 730 - Solid Waste (S6401) Totals		Invoice 8	<hr/> \$21,303.73
		Transactions	

Fund 800 - Risk Management(S0203)

Department 10 - Legal

Program 100000 - Main

Account 52430 - Uniforms and Tools



Board of Public Works Claim Register

Invoice Date Range 10/01/22 - 10/14/22

4291 - Monroe Optical, INC	10-safety shoes-J. Zike (10M)-4/22/22	10/14/2022	100.00
1448 - Shoe Carnival, INC	10-Safety Shoe s-J Shake (9.5) 8/8/22	10/14/2022	84.98
1448 - Shoe Carnival, INC	10-Safety Shoe K Hardin (11.5) 8/13/22	10/14/2022	100.00
Account 52430 - Uniforms and Tools Totals		Invoice 3	<hr/> \$284.98
		Transactions	
Account 53130 - Medical			
8394 - Robert J Grubb	10- reimbursement CDL physical 9/5/22	10/14/2022	99.00
3861 - Brian D Robertson	10- reimbursement CDL physical 2022-9/16/22	10/14/2022	100.00
Account 53130 - Medical Totals		Invoice 2	<hr/> \$199.00
		Transactions	
Account 53420 - Worker's Comp & Risk			
7792 - ONB Benefit Administration LLC (JWF Specialty)	10- Worker's Comp Payments (9.8.22-9.14.22)	10/04/2022	2,347.05
7792 - ONB Benefit Administration LLC (JWF Specialty)	10- Worker's Comp Payments (8.25.22-8.31.22)	10/04/2022	6,293.36
7792 - ONB Benefit Administration LLC (JWF Specialty)	10 -Worker's Comp Payments (9.1.22-9.7.22)	10/04/2022	755.38
Account 53420 - Worker's Comp & Risk Totals		Invoice 3	<hr/> \$9,395.79
		Transactions	
Program 100000 - Main Totals		Invoice 8	<hr/> \$9,879.77
		Transactions	
Department 10 - Legal Totals		Invoice 8	<hr/> \$9,879.77
		Transactions	
Fund 800 - Risk Management(S0203) Totals		Invoice 8	<hr/> \$9,879.77
		Transactions	
Fund 801 - Health Insurance Trust			
Department 12 - Human Resources			
Program 120000 - Main			
Account 53990 - Other Services and Charges			
17785 - The Howard E. Nyhart Company, INC	12-Nyhart ER Cont \$242.32	10/03/2022	242.32
18539 - Life Insurance Company Of North America	12-September 2022, Bill Ref # 103094_09012022	10/14/2022	4,051.10



Board of Public Works Claim Register

Invoice Date Range 10/01/22 - 10/14/22

Account 53990 - Other Services and Charges Totals		Invoice 2	\$4,293.42
		Transactions	
Account 53990.1201 - Other Services and Charges Health Insurance			
3928 - Aim Medical Trust	12-October 2022 AIM Premium Invoice	10/05/2022	888,850.38
	\$888850.38		
3908 - CIGNA Healthcare	12-September 2022 Dental Funding	10/05/2022	25,977.12
Account 53990.1201 - Other Services and Charges Health Insurance Totals		Invoice 2	\$914,827.50
		Transactions	
Account 53990.1278 - Other Services and Charges Disability LTD			
18539 - Life Insurance Company Of North America	12-September 2022, Bill Ref #	10/14/2022	8,906.24
	103094_09012022		
Account 53990.1278 - Other Services and Charges Disability LTD Totals		Invoice 1	\$8,906.24
		Transactions	
Program 120000 - Main Totals		Invoice 5	\$928,027.16
		Transactions	
Department 12 - Human Resources Totals		Invoice 5	\$928,027.16
		Transactions	
Fund 801 - Health Insurance Trust Totals		Invoice 5	\$928,027.16
		Transactions	
Fund 802 - Fleet Maintenance(S9500)			
Department 17 - Fleet Maintenance			
Program 170000 - Main			
Account 52230 - Garage and Motor Supplies			
50605 - Bauer Built, INC	17 - tires for stock-9/22/22	10/14/2022	10,004.90
4693 - Monroe County Tire & Supply, INC	17 - P225/65R16 Firestone All season Tires	10/14/2022	460.84
	(4)		
786 - Richard's Small Engine, INC	17- small engine parts - Pivot Deck Lift	10/14/2022	53.36
786 - Richard's Small Engine, INC	17-fuel & oil filter,Oil,spark plug,inner air	10/14/2022	301.20
	filter, air filter		
5111 - Spencer Trailers INC	17 #569 tires for Parking's trailer	10/14/2022	756.00
Account 52230 - Garage and Motor Supplies Totals		Invoice 5	\$11,576.30
		Transactions	
Account 52320 - Motor Vehicle Repair			



Board of Public Works Claim Register

Invoice Date Range 10/01/22 - 10/14/22

4150 - Alexander's LLC	17- #569 trailer	10/14/2022	182.00
4336 - American Eagle Auto Glass of Terre Haute, INC	parts: Bearings, Hub/drum, seal, grease, wheel 17- #961 windshield	10/14/2022	295.00
4877 - Asher Group, INC	17- #960 u-joint	10/14/2022	56.80
244 - Bloomington Ford, INC	17- Sensor Assembly parts for ford	10/14/2022	52.91
244 - Bloomington Ford, INC	17- Exhaust Sensor parts	10/14/2022	69.68
244 - Bloomington Ford, INC	17- Wheel Assembly parts	10/14/2022	406.80
244 - Bloomington Ford, INC	17- Bolts, Shaft assembly, Rack&Pin gear parts for ford	10/14/2022	1,826.87
594 - Curry Auto Center, INC	17- GM parts - sensor & Booster Kit	10/14/2022	203.17
1727 - Ditch Witch of Illinois	17- storage tank for #676	10/14/2022	878.73
51827 - Fire Service, INC	17- parts for #332	10/14/2022	331.05
796 - Interstate Battery System of Bloomington, INC	17 - 1 SRM-24 Battery	10/14/2022	83.67
796 - Interstate Battery System of Bloomington, INC	17 - (1)MT-40R Battery	10/14/2022	97.47
796 - Interstate Battery System of Bloomington, INC	17 - 2 MTP-67R Batteries	10/14/2022	198.62
796 - Interstate Battery System of Bloomington, INC	17 - 5-31MHD, MTP65HD, MTP-86, MTP- 90/T5 batteries	10/14/2022	923.08
4439 - JX Enterprises, INC	17-misc. Peter built parts -bracket p/s reservoir, transmission	10/14/2022	711.98
4439 - JX Enterprises, INC	17-misc. Peter built parts - Battery disconnect switch	10/14/2022	178.99
4439 - JX Enterprises, INC	17 -Peter built part-fuel filters	10/14/2022	472.88
6262 - Koenig Equipment, INC	17- tune up kit for Tractor #518	10/14/2022	230.37
53385 - O'Reilly Automotive Stores, INC	17 - Fuel Filter	10/14/2022	4.39
53385 - O'Reilly Automotive Stores, INC	17- misc. truck parts - Cop Coil	10/14/2022	26.25
53385 - O'Reilly Automotive Stores, INC	17 - U-Joint	10/14/2022	36.80
53385 - O'Reilly Automotive Stores, INC	17 - Cop Coil & Fuel Filter	10/14/2022	100.60



Board of Public Works Claim Register

Invoice Date Range 10/01/22 - 10/14/22

53385 - O'Reilly Automotive Stores, INC	17 - Rad Fan Assembly	10/14/2022	316.74
53385 - O'Reilly Automotive Stores, INC	17- (2) quick-strut, Manual Steering Rack & Pinion Assembly	10/14/2022	800.99
19681 - Southeastern Equipment Co, INC	17 - #459 wire rope sensor	10/14/2022	3,362.38
54351 - Sternberg, INC	17 - OSL #428 part and service	10/14/2022	8,595.37
54351 - Sternberg, INC	17 - Disc pads breaks- international part.	10/14/2022	173.77
54351 - Sternberg, INC	17 -(2) Cylinders, Hub assembly, Seal - international parts	10/14/2022	1,807.15
582 - Town & Country Chrysler Dodge Jeep, INC	17- Fuel injector- Chrysler part	10/14/2022	91.80
582 - Town & Country Chrysler Dodge Jeep, INC	17- Wheel Center Cap -Chrysler parts	10/14/2022	83.00
582 - Town & Country Chrysler Dodge Jeep, INC	17- Rear view Camera- Chrysler parts	10/14/2022	262.65
622 - Truck Country of Indiana, INC (Stoops Freightliner	17- Freightliner parts-bin	10/14/2022	29.39
7555 - VoMac Truck Sales & Service INC	17- mack parts - Wipers	10/14/2022	277.88
Account 52320 - Motor Vehicle Repair Totals		Invoice 33 Transactions	<u>\$23,169.23</u>
Account 52420 - Other Supplies			
177 - Indiana Oxygen Company, INC	17 - Carbon Dioxide for torch welder and etc	10/14/2022	32.60
177 - Indiana Oxygen Company, INC	17 - shop supplies for torch welder and etc	10/14/2022	241.36
6216 - Terminal Supply, INC	17 - shop supplies drill bits, crimper & Metri-pak connectors	10/14/2022	340.46
6216 - Terminal Supply, INC	17 - (30- LED WorkLamp, 900 Lumens	10/14/2022	780.00
Account 52420 - Other Supplies Totals		Invoice 4 Transactions	<u>\$1,394.42</u>
Account 53140 - Exterminator Services			
51538 - Economy Termite & Pest Control, INC	17-Exterminator Service @ Fleet - 9/20/2022 BC 2021-108	10/14/2022	95.00
Account 53140 - Exterminator Services Totals		Invoice 1 Transactions	<u>\$95.00</u>
Account 53610 - Building Repairs			



Board of Public Works Claim Register

Invoice Date Range 10/01/22 - 10/14/22

392 - Koorsen Fire & Security, INC	17 - Annual Fire Extinguisher inspections	BC 2022-016	10/14/2022	318.75
	Account 53610 - Building Repairs Totals		Invoice 1	<u>\$318.75</u>
			Transactions	
Account 53920 - Laundry and Other Sanitation Services				
19171 - Aramark Uniform & Career Apparel Group, INC	17-mat rentals and shop towels, 9-21-22		10/14/2022	77.36
19171 - Aramark Uniform & Career Apparel Group, INC	17 - Mat and Towels Rental, 9-14-2022		10/14/2022	77.36
19171 - Aramark Uniform & Career Apparel Group, INC	17 - City portion Of uniform rentals- 09/14/2022		10/14/2022	19.50
19171 - Aramark Uniform & Career Apparel Group, INC	17 - City portion Of uniform rentals- 09/21/2022		10/14/2022	19.50
	Account 53920 - Laundry and Other Sanitation Services Totals		Invoice 4	<u>\$193.72</u>
			Transactions	
	Program 170000 - Main Totals		Invoice 48	<u>\$36,747.42</u>
			Transactions	
	Department 17 - Fleet Maintenance Totals		Invoice 48	<u>\$36,747.42</u>
			Transactions	
	Fund 802 - Fleet Maintenance(\$9500) Totals		Invoice 48	<u>\$36,747.42</u>
			Transactions	
Fund 804 - Insurance Voluntary Trust				
Department 12 - Human Resources				
Program 120000 - Main				
Account 53990.1271 - Other Services and Charges Section 125 - URM- City				
17785 - The Howard E. Nyhart Company, INC	12-City URM		10/03/2022	79.26
17785 - The Howard E. Nyhart Company, INC	12-City/Util URM		10/03/2022	49.01
17785 - The Howard E. Nyhart Company, INC	12-City URM		10/04/2022	89.98
17785 - The Howard E. Nyhart Company, INC	12-City URM		10/05/2022	55.00
17785 - The Howard E. Nyhart Company, INC	12-City URM			50.00
17785 - The Howard E. Nyhart Company, INC	12-City/Util URM			67.54
	Account 53990.1271 - Other Services and Charges Section 125 - URM- City Totals		Invoice 6	<u>\$390.79</u>
			Transactions	



Board of Public Works Claim Register

Invoice Date Range 10/01/22 - 10/14/22

Account 53990.1273 - Other Services and Charges Term Life

18539 - Life Insurance Company Of North America	12-September 2022, Bill Ref # 103094_09012022	10/14/2022	17,911.60
Account 53990.1273 - Other Services and Charges Term Life Totals		Invoice 1	\$17,911.60
		Transactions	

Account 53990.1277 - Other Services and Charges Disability STD

18539 - Life Insurance Company Of North America	12-September 2022, Bill Ref # 103094_09012022	10/14/2022	10,365.20
Account 53990.1277 - Other Services and Charges Disability STD Totals		Invoice 1	\$10,365.20
		Transactions	

Account 53990.1281 - Other Services and Charges Section 125 - URM- Util

17785 - The Howard E. Nyhart Company, INC	12-Util URM	10/03/2022	126.86
17785 - The Howard E. Nyhart Company, INC	12-City/Util URM	10/03/2022	10.00
17785 - The Howard E. Nyhart Company, INC	12-City/Util URM		20.00
Account 53990.1281 - Other Services and Charges Section 125 - URM- Util Totals		Invoice 3	\$156.86
		Transactions	

Account 53990.1282 - Other Services and Charges Section 125 - DDC- Util

17785 - The Howard E. Nyhart Company, INC	12-UtilDDC	10/04/2022	1,300.02
Account 53990.1282 - Other Services and Charges Section 125 - DDC- Util Totals		Invoice 1	\$1,300.02
		Transactions	

Account 53990.1283 - Other Services and Charges Health Savings Account

17785 - The Howard E. Nyhart Company, INC	12-Nyhart HSA EE Contributions 10-7-2022		18,255.76
Account 53990.1283 - Other Services and Charges Health Savings Account Totals		Invoice 1	\$18,255.76
		Transactions	
Program 120000 - Main Totals		Invoice 13	\$48,380.23
		Transactions	
Department 12 - Human Resources Totals		Invoice 13	\$48,380.23
		Transactions	
Fund 804 - Insurance Voluntary Trust Totals		Invoice 13	\$48,380.23
		Transactions	

Fund 978 - City 2016 GO Bond Proceeds

Department 06 - Controller's Office



Board of Public Works Claim Register

Invoice Date Range 10/01/22 - 10/14/22

Program **06016C - 2016 C Jackson Trail**

Account **54310 - Improvements Other Than Building**

399 - American Structurepoint, INC

	13-Jackson Creek Trail Phase II (CE)_CI-8/1- BC 2020-77	10/14/2022	1,703.15
	8/31/22		
Account 54310 - Improvements Other Than Building	Totals	Invoice 1	<u>\$1,703.15</u>
		Transactions	
Program 06016C - 2016 C Jackson Trail	Totals	Invoice 1	<u>\$1,703.15</u>
		Transactions	
Department 06 - Controller's Office	Totals	Invoice 1	<u>\$1,703.15</u>
		Transactions	
Fund 978 - City 2016 GO Bond Proceeds	Totals	Invoice 1	<u>\$1,703.15</u>
		Transactions	
	Grand Totals	Invoice 342	<u><u>\$2,057,931.91</u></u>
		Transactions	

REGISTER OF CLAIMS
Board: Board of Public Works Claim Register

Date:	Type of Claim	FUND	Description	Bank Transfer	Amount
10/14/22	Claims				\$2,057,931.91
					<u>\$2,057,931.91</u>

ALLOWANCE OF CLAIMS

We have examined the claims listed on the foregoing register of claims, consisting of claims, and except for the claims not allowed as shown on the register, such claims are hereby allowed in the total amount of \$2,057,931.91

Dated this 11th day of October year of 2022.

Kyla Cox Deckard, President	Jennifer Lloyd, Vice President	Elizabeth Karon, Secretary

I hereby certify that each of the above listed voucher(s) or bill(s) is (are) true and correct and I have audited same in accordance with IC 5-11-10-1.6.

Fiscal Office _____