

Board of Public Works Meeting

October 25, 2022



The City will offer virtual options, including CATS public access television (live and tape-delayed) and

Public comments and questions will be encouraged via Zoom or bloomington.in.gov rather than in person

AGENDA
BOARD OF PUBLIC WORKS
October 25, 2022

A Regular Meeting of the Board of Public Work will be held Tuesday, October 25, 2022 at 5:30 p.m. in the Council Chambers (Rm #115) of City Hall at the Showers Building, 401 N. Morton Street, Bloomington, Indiana and via Zoom by using the following link:

<https://bloomington.zoom.us/j/84922855646?pwd=SUlrSWRja0thVFQ3WEtWTVud2RMdz09>

Meeting ID: 849 2285 5646 Passcode: 825226

The City offers virtual options, including CATS public access television (live and tape- delayed). Comments and questions will be encouraged via Zoom or bloomington.in.gov rather than in person.

Auxiliary aids for people with disabilities are available upon request with adequate notice. Please call 812-349-3411 or email public.works@bloomington.in.gov.

I. MESSAGES FROM BOARD MEMBERS

II. PETITIONS AND REMONSTANCES

III. CONSENT AGENDA

1. Approval of Minutes October 11, 2022
2. Supplement #1 to 2022 Service Agreement with Koorsen Fire & Security
3. Supplement #2 to 2022 Service Agreement with Cummins, Inc.
4. 2023 Service Agreement with B&L Sheet Metal
5. 2023 Service Agreement with Cassidy Electrical Contractors
6. 2023 Service Agreement with City Lawn
7. 2023 Service Agreement with Koorsen Fire & Security
8. Contract with Air Technology Solutions for Filter Changes in Air Filtration Units at Fire Department Facilities
9. Service Agreement with VET Environmental
10. Service Agreement with Strauser Construction for Repair and Maintenance Services
11. Renewal #2 with ReCollect Digital Recycling Education Software
12. Outdoor Lighting Service Agreement with Duke Energy for Phase III of Showers Complex Led Conversion Project
13. Outdoor Lighting Service Agreement with Duke Energy for Intersection of W. Allen and S. Madison
14. Approval of Payroll

IV. NEW BUSINESS

1. Request from AEG for Lane and Sidewalk Closures
2. Change Order #1 to Contract with Strauser Construction for Lower Level Renovation at Fire Station #2

V. STAFF REPORTS & OTHER BUSINESS

VI. APPROVAL OF CLAIMS

VII. ADJOURNMENT

The Board of Public Works meeting was held Tuesday, October 11, 2022 at 5:30 pm in the Council Chambers of City Hall at 401 N. Morton St., Bloomington, Indiana and virtually through Zoom with Cox Deckard presiding.

**REGULAR MEETING OF
THE BOARD OF PUBLIC
WORKS**

Present: Kyla Cox Deckard
Elizabeth Karon
Jennifer Lloyd

ROLL CALL

City Staff: Adam Wason – Public Works
Christina Smith -- Public Works
Chris Wheeler – City Legal
Maria McCormick – Housing & Neighborhood Development
Mike Arnold – Housing & Neighborhood Development
Beth Rosenbarger – Planning & Transportation
Sara Gomez -- Engineering
Neil Kopper -- Engineering
Paul Kehrberg – Engineering
Jason Kerr -- Engineering

None

**MESSAGES FROM BOARD
MEMBERS**

None

**PETITIONS &
REMONSTRANCES**

Maria McCormick, Housing and Neighborhood Development, presented Abatement at 304 N. Hopewell. See meeting packet for details

**TITLE VI ENFORCEMENT
Abatement at 304 N. Hopewell**

Board Comments: Lloyd asked when the property had been visited last. McCormick stated she had driven by the previous day and it still looks the same as the pictures that were presented. Karon asked if there had been any conversation with the owner since the work session. McCormick stated that she had not been in contact. Cox Deckard asked if the owner or tenants were in the audience. McCormick stated that the owner is deceased and the tenants are her adult children.

Karon made a motion to approve the abatement at 304 N. Hopewell. Lloyd seconded. All in favor, motion is passed. Chris Wheeler asked that the motion include the language “continuous.” Karon amended her motion to approve the continuous abatement at 304 N. Hopewell. Lloyd seconded. All in favor, motion is passed.

1. Approval of Minutes; September 27, 2022
2. Resolutuion 2022-79; Renew Mobile Vendor; Cup of Joy
3. Outdoor Lighting Service Agreement with Duke Energy for E. 10th Street between Walnut and Indiana; Phase I
4. Service Agreement with Tabor Bruce Architecture & Design, Inc. for Design and Inspection Services
5. Supplement #1 to 2022 HFI HVAC Service Agreement
6. Supplement #2 to 2022 HFI Plumbing Service Agreement
7. Approval of Payroll

CONSENT AGENDA

Karon made a motion to approve the Consent Agenda. Lloyd seconded. All in favor, motion is passed.

Mike Arnold, Housing and Neighborhood Development, presented Resolution 2022-80 to Uphold Order to Remove or Repair at 1635 N. College Ave. See meeting packet for details.

Board Comments: Cox Deckard asked if owners had offered a timeline of when they will have the building more secure. Arnold stated that a deadline of October 15, 2022 had been given as a timeline from property owner.

Karon made a motion to approve Resolution 2022-80 to Uphold Order to Remove or Repair at 1635 N. College Ave. Lloyd seconded. All in favor, motion is passed.

Beth Rosenbarger, Planning & Transportation, presented Contract with Toole Design Group, LLC for the College Ave. and Walnut St. Corridor Study. See meeting packet for details.

Board Comments: Cox Deckard asked if the City had worked with Toole Design on any previous projects. Rosenbarger confirmed that they had worked on the City's transportation plan. Cox Deckard asked how the implementation of the study will be funded. Rosenbarger stated that is not known at this time. Cox Deckard asked if the study will take place in 2023. Rosenbarger stated that some of the study will begin now, but will be concluded by the end of 2023. Cox Deckard asked what the process is for working on preparing for the implementation from a staff perspective. Rosenbarger stated that there will be an internal management team and a larger group that she will be managing to reach out to monitor the progress. Cox Deckard asked when the study would begin. Rosenbarger said as soon as the contract is approved and executed. Cox Deckard asked about the process of the recommendation from the study. Rosenbarger stated that there is a set of goals outlined. Cox Deckard asked if those goals are the same as what was recommended during the transportation plan. Rosenbarger answered that they are similar, but the Plan Commission made changes and those changes were amended into the plan. Karon confirmed that there had been changes by the Plan Commission. Rosenbarger also confirmed. Cox Deckard stated she was misunderstanding the approach of the study because Toole originally made recommendations for the transportation plan. Rosenbarger stated she is confident that the professionals of Toole Design will lead the study independent of the recommendation. Cox Deckard stated she would like to talk to Toole Design and decided to abstain from the vote.

Karon made a motion to approve Contract with Toole Design Group, LLC, for the College Ave. and Walnut St. Corridor Study. Lloyd seconded. Motion is passed, with one abstention.

Sara Gomez, Engineering, presented Change Orders #2, #3, and #4 for the Neighborhood Greenways Project. See meeting packet for details.

Board Comments: None.

Karon made a motion to Change Orders #2, #3, and #4 for the Neighborhood Greenways Project. Lloyd seconded. All in favor, motion is passed.

Neil Kopper, Engineering, presented Memorandum of Understanding with the City of Bloomington Utilities Department for Construction Cost Sharing on the W. Allen Neighborhood Greenway Project. See meeting packet for details.

Board Comments: Lloyd asked what green infrastructure was in this case. Kopper answered that it is a raingarden.

Karon made a motion to approve the Memorandum of Understanding with the City of Bloomington Utilities Department for Construction Cost Sharing on the W. Allen Neighborhood Greenway Project. Lloyd seconded. All in favor, motion is passed.

NEW BUSINESS

Resolution 2022-80 to Uphold Order to Remove or Repair at 1635 N. College Ave.

Contract with Toole Design Group, LLC for College Ave. and Walnut St. Corridor Study

Change Orders #2, #3, and #4 for the Neighborhood Greenways Project

Memorandum of Understanding with the City of Bloomington Utilities Department for Construction Cost Sharing on the W. Allen Neighborhood Greenway Project

Jason Kerr, Engineering, presented Request from AEG for Lane and Sidewalk Closures. See meeting packet for details.

Request from AEG for Lane and Sidewalk Closures

Board Comments: None

Karon made a motion to approve Request from AEG for Lane and Sidewalk Closures. Lloyd seconded. All in favor, motion is passed.

Paul Kehrberg, Engineering, presented Request from Strauser Construction for Full Street Closure along E. 19th St. from N. Grant St. to N. Dunn St. (October 12, 2022-August 08, 2023). See meeting packet for details.

Request from Strauser Construction for Full Street Closure along E. 19th St. from N. Grant St. to N. Dunn St. (October 12, 2022-August 08, 2023)

Board Comments: Karon commented that she appreciated the work that is being done for an improved solution in that area.

Karon made a motion to approve Request from Strauser Construction for Full Street Closure along E. 19th St. from N. Grant St. to N. Dunn St. (October 12, 2022-August 08, 2023). Lloyd seconded. All in favor, motion is passed.

Paul Kehrberg, Engineering, presented Request from Strauser Construction for Right-of-Way Use on E. 9th St. (October 10, 2022-January 6, 2023). See meeting packet for details.

Request from Strauser Construction for Right-of-Way Use on E. 9th St. (October 10, 2022-January 6, 2023)

Board Comments: Karon made note that the application states work ends in January 2022, but that work actually ends January 2023.

Karon made a motion to approve Request from Strauser Construction for Right-of-Way Use on E. 9th St. (October 10, 2022-January 6, 2023). Lloyd seconded. All in favor, motion is passed.

Adam Wason, Public Works, presented Contract with TAPCO for “No Turn on Red” Sign Project. See meeting packet for details.

Contract with TAPCO for “No Turn on Red” Sign Project

Board Comments: None

Karon made a motion to approve Contract with TAPCO for “No Turn on Red” Sign Project. Lloyd seconded. All in favor, motion is passed.

Wason provided that scooter enforcement officers are now working to document improperly parked scooters. He also mentioned an announcement from the Mayor’s office implementing an 11:00 p.m. cut-off time for scooter usage. Wason also noted the great relationship with Centerstone and moving forward with increasing the number of people who are working on the crews of Brighten B-town.

STAFF REPORTS AND OTHER BUSINESS

Karon made a motion to approve claims in the amount of \$2,057,931.91. Lloyd seconded. All in favor, motion is passed.

CLAIMS

Cox Deckard called for adjournment at 6:05 p.m.

ADJOURNMENT

Accepted By:

Kyla Cox Deckard, President

Jennifer Lloyd, Vice President

Elizabeth Karon, Secretary

Date:

Attest to:



Board of Public Works Staff Report

Project/Event: Supplement #1 to Service Agreement with Koorsen Fire and Security for Fire Alarm Inspections, Repairs, and Maintenance for Public Works Facilities

Petitioner/Representative: Public Works Facilities Division

Staff Representative: J. D. Boruff, Operations and Facilities Director

Meeting Date: October 25, 2022

This supplement is being requested for the increase of the original not to exceed amount of \$20,000. The supplement we're requesting would be an additional \$10,000. This Supplement #1 increases the not to exceed amount of the Agreement to \$30,000.00. When determining the original "not to exceed" amount for the original agreement, we underestimated the amount of work we would have for this contractor to perform.

Respectfully submitted,

A handwritten signature in black ink that reads "JD Boruff".

J. D. Boruff
Operations and Facilities Director
Public Works Department

City of Bloomington Contract and Purchase Justification Form

Vendor: Koorsen Fire
and Security

Contract Amount: \$10,000 added in
Supplement #1

This form should be completed and attached to the contract documents and forwarded to the Legal Department Attorney assigned to your Department. Contracts will not be approved by the Controller if a completed form is not included with the contract documents.

PURCHASE INFORMATION

1. Check the box beside the procurement method used to initiate this procurement: (Attach a quote or bid tabulation if applicable)

<input type="checkbox"/> Request for Quote (RFQ)	<input type="checkbox"/> Request for Proposal (RFP)	<input type="checkbox"/> Sole Source	<input checked="" type="checkbox"/> Not Applicable (NA)
<input type="checkbox"/> Invitation to Bid (ITB)	<input type="checkbox"/> Request for Qualifications (RFQ)	<input type="checkbox"/> Emergency Purchase	

2. List the results of procurement process. Give further explanation where requested. Yes No

# of Submittals: 0	Yes	No		
Met city requirements?	<input type="checkbox"/>	<input type="checkbox"/>	Was the lowest cost selected? (If no, please state below why it was not.)	<input type="checkbox"/> <input checked="" type="checkbox"/>
Met item or need requirements?	<input type="checkbox"/>	<input type="checkbox"/>	This is a supplement to an existing service agreement	
Was an evaluation team used?	<input type="checkbox"/>	<input type="checkbox"/>		
Was scoring grid used?	<input type="checkbox"/>	<input type="checkbox"/>		
Were vendor presentations requested?	<input type="checkbox"/>	<input type="checkbox"/>		

3. State why this vendor was selected to receive the award and contract:

This is a supplement to an existing service agreement that was approved by the Board of Public Works on March 15th, 2022. We are adding an additional \$10,000 to the service agreement. Total adjusted cost is \$30,000.

JD Boruff

Director of Facilities

Public Works

Print/Type Name

Print/Type Title

Department

**SUPPLEMENT #1 TO 2022 SERVICE AGREEMENT FOR
KOORSEN FIRE AND SECURITY**

This Supplement #1 amends the original 2022 Service Agreement with Koorsen Fire and Security for Fire Alarm Monitoring, Inspection, and Repair Services for all facilities maintained by the Department, which was entered into on March 15, 2022, and which is attached hereto and incorporated herein by reference.

1. **Article 4. Compensation** provides that the not to exceed cost of this Service Agreement could be amended to add additional services not set forth in the original agreement. The original Not to Exceed cost was \$20,000. The Supplement #1 would increase the total compensation allowed under this Agreement by \$10,000, to a new Not to Exceed cost of to \$30,000, after the Department determined it had underestimated the amount of work they would have for HFI to perform
2. In all other aspects, the Agreement shall remain in effect as originally written.

IN WITNESS WHEREOF, the parties have caused this Amendment to be executed on the day and year last written below.

OWNER

Kyla Cox Deckard
President, Board of Public Works

Jennifer Lloyd
Vice President, Board of Public Works

Elizabeth Karon
Secretary, Board of Public Works

Date: _____

John Hamilton
Mayor

Date: _____

CONTRACTOR

John York

Date: _____



Board of Public Works Staff Report

Project/Event: Supplement #2 to Service Agreement with Cummins Inc., for Generator Repair and Maintenance

Petitioner/Representative: Public Works Facilities Division

Staff Representative: J. D. Boruff, Operations and Facilities Director

Meeting Date: October 25, 2022

This supplement is being requested for the increase of the previous not to exceed amount of \$28,332.00. The supplement we're requesting would be an additional \$10,000. This Supplement #2 increases the not to exceed amount of the Agreement to \$38,332.21. After increasing an additional \$20,000 on June 7th, we underestimated the amount of plumbing work remaining.

Respectfully submitted,

A handwritten signature in black ink that reads "JD Boruff".

J. D. Boruff
Operations and Facilities Director
Public Works Department

City of Bloomington Contract and Purchase Justification Form

Vendor: Cummins, Inc

Contract Amount: \$10,000

This form should be completed and attached to the contract documents and forwarded to the Legal Department Attorney assigned to your Department. Contracts will not be approved by the Controller if a completed form is not included with the contract documents.

PURCHASE INFORMATION

1. Check the box beside the procurement method used to initiate this procurement: (Attach a quote or bid tabulation if applicable)

<input type="checkbox"/> Request for Quote (RFQ)	<input type="checkbox"/> Request for Proposal (RFP)	<input type="checkbox"/> Sole Source	<input checked="" type="checkbox"/> Not Applicable (NA)
<input type="checkbox"/> Invitation to Bid (ITB)	<input type="checkbox"/> Request for Qualifications (RFQu)	<input type="checkbox"/> Emergency Purchase	

2. List the results of procurement process. Give further explanation where requested. Yes No

# of Submittals: 0	Yes	No		
Met city requirements?	<input type="checkbox"/>	<input type="checkbox"/>	Was the lowest cost selected? (If no, please state below why it was not.)	<input type="checkbox"/> <input checked="" type="checkbox"/>
Met item or need requirements?	<input type="checkbox"/>	<input type="checkbox"/>	This is a supplement to an existing service agreement	
Was an evaluation team used?	<input type="checkbox"/>	<input type="checkbox"/>		
Was scoring grid used?	<input type="checkbox"/>	<input type="checkbox"/>		
Were vendor presentations requested?	<input type="checkbox"/>	<input type="checkbox"/>		

3. State why this vendor was selected to receive the award and contract:

This supplement is being requested for the increase of the previous not to exceed amount of \$28,332.21. The supplement we're requesting would be an additional \$10,000. This Supplement #2 increases the not to exceed amount of the Agreement to \$38,332.21. After increasing an additional \$20,000 on June 7th, we underestimated the amount of plumbing work remaining.

 JD Boruff

 Director of Facilities

 Public Works

Print/Type Name

Print/Type Title

Department

**SUPPLEMENT #2 TO 2022 SERVICE AGREEMENT
BETWEEN
CITY OF BLOOMINGTON
AND
CUMMINS, INC.**

This Supplement #2 increases the Not to Exceed amount of compensation allowed under this Service Agreement as follows:

1. On June 7, 2022, the Board of Public Works approved Supplement #1 to the 2022 Services Agreement with Cummins, Inc.

2. **Article 4. Compensation** contained the not to exceed amount of compensation that was originally allowed under this Service Agreement as \$8,332.21. Supplement #1 added \$20,000 in compensation, for a revised NTE cost of \$28,332.21 for this 2022 Service Agreement. Supplement #2 will add an additional \$10,000 in compensation, for a revised NTE cost of \$38,332.21.

3. In all other respects, the Agreement shall remain in effect as originally written.

IN WITNESS WHEREOF, the parties have caused this Supplement #2 to be executed the day and year last written below:

CITY OF BLOOMINGTON

CUMMINS, INC

By: _____
Kyla Cox Deckard, President
Board of Public Works

By: _____

Name and Title

Date: _____

Date: _____

By: _____
Adam Wason, Director
Public Works Department

Date: _____

By: _____
John Hamilton, Mayor

Date: _____



Board of Public Works Staff Report

Project/Event: 2023 Service Agreement with B & L Sheet Metal and Roofing Repair and Sealing Services

Petitioner/Representative: Public Works Facilities Division

Staff Representative: J. D. Boruff, Operations and Facilities Director

Meeting Date: October 25, 2022

This contract is for repair and sealing of roofing, windows, doors, walls, and guttering at all City facilities maintained by the Public Works Facilities Division.

Staff recommends awarding the contract to B & L Sheet Metal and Roofing not to exceed \$35,000.00.

Respectfully submitted,

A handwritten signature in black ink that reads "JD Boruff". The signature is written in a cursive, slightly stylized font.

J. D. Boruff
Operations and Facilities Director
Public Works Department

City of Bloomington Contract and Purchase Justification Form

Vendor: B&L Sheet Metal

Contract Amount: \$35,000

This form should be completed and attached to the contract documents and forwarded to the Legal Department Attorney assigned to your Department. Contracts will not be approved by the Controller if a completed form is not included with the contract documents.

PURCHASE INFORMATION

1. Check the box beside the procurement method used to initiate this procurement: (Attach a quote or bid tabulation if applicable)

<input type="checkbox"/> Request for Quote (RFQ)	<input type="checkbox"/> Request for Proposal (RFP)	<input type="checkbox"/> Sole Source	<input checked="" type="checkbox"/> Not Applicable (NA)
<input type="checkbox"/> Invitation to Bid (ITB)	<input type="checkbox"/> Request for Qualifications (RFQu)	<input type="checkbox"/> Emergency Purchase	

2. List the results of procurement process. Give further explanation where requested.

# of Submittals: 0	Yes	No	Was the lowest cost selected? (If no, please state below why it was not.)	Yes	No
Met city requirements?	<input checked="" type="checkbox"/>	<input type="checkbox"/>	This is a service agreement we renew every year.	<input type="checkbox"/>	<input checked="" type="checkbox"/>
Met item or need requirements?	<input checked="" type="checkbox"/>	<input type="checkbox"/>			
Was an evaluation team used?	<input type="checkbox"/>	<input checked="" type="checkbox"/>			
Was scoring grid used?	<input type="checkbox"/>	<input checked="" type="checkbox"/>			
Were vendor presentations requested?	<input type="checkbox"/>	<input checked="" type="checkbox"/>			

3. State why this vendor was selected to receive the award and contract:

We always renew B&L Sheet Metal and Roofing as a vendor every year.

JD Boruff

Director of Facilities Manag

Department of Public Works

Print/Type Name

Print/Type Title

Department

**AGREEMENT BETWEEN CITY OF BLOOMINGTON
PUBLIC WORKS DEPARTMENT AND
B & L SHEET METAL AND ROOFING**

This Agreement, entered into on this 25th day of October, 2022, by and between the City of Bloomington Department of Public Works (the “Department”), and B & L Sheet Metal and Roofing (“Contractor”).

Article 1. Scope of Services Contractor shall perform repair and maintenance services of the following types: Repair of shingled, metal, and membrane roofs. Waterproofing and sealing of doors, windows, and various types of walls. Repair of guttering and downspouts. These services will be performed at City facilities (“Services”) for a set price of Eighty-Five Dollars (\$85.00) per person, per hour Monday-Friday 7:00 am – 5:00 pm. Any work performed outside of those hours, including evenings, weekends, and holidays, will be performed at the rate of One Hundred Ten Dollars (\$110.00) per person, per hour. It is understood that the Contractor will send a minimum of two (2) employees for all roofing service work. Contractor shall diligently provide the Services under this Agreement and shall complete the Services described in this Agreement in a timely manner consistent with the Standard of Care identified in Article 2. Contractor shall complete the Services required under this Agreement on or before December 31st, 2023, unless the parties mutually agree to a later completion date. Completion shall mean completion of all work related to the Services. In the performance of Contractor’s work, Contractor agrees to maintain such coordination with the Department as may be requested and desirable, including primary coordination with J. D. Boruff, Operations and Facilities Director, Public Works Department. Contractor agrees that any information or documents, including digital GIS information, supplied by the Department pursuant to Article 3, below, shall be used by Contractor for this project only, and shall not be reused or reassigned for any other purpose without the written permission of the Department.

Article 2. Standard of Care Contractor shall be responsible for completion of the Services in a manner consistent with that degree of care and skill ordinarily exercised by members of the same profession currently practicing under similar circumstances (“Standard of Care”). The Department shall be the sole judge of the adequacy of Contractor’s work in meeting the Standard of Care; however, the Department shall not unreasonably withhold its approval as to the adequacy of Contractor’s performance. Upon notice to Contractor and by mutual agreement between the parties, Contractor will, without additional compensation, correct or replace any and all Services not meeting the Standard of Care.

Article 3. Responsibilities of the Department The Department shall provide all necessary information regarding requirements for the Services. The Department shall furnish such information as necessary for the orderly progress of the work, and Contractor shall be entitled to rely upon the accuracy and completeness of such information. The Department’s Project Manager shall act on its behalf with respect to this Agreement.

Article 4. Compensation The Department shall pay Contractor for all fees and expenses in an amount not to exceed Thirty-Five Thousand Dollars (\$35,000.00). Contractor shall submit an invoice to the Department upon the completion of the Services described in Article 1. **Invoices shall be sent via email to public.works@bloomington.in.gov or via first class mail postage prepaid to Public Works Department, 401 N. Morton Street, Suite 120, Bloomington, IN 47404.** Invoices may be sent via first class mail postage prepaid or via email. Payment will be remitted to Contractor within forty-five (45) days of receipt of invoice. Additional services not set forth in Article 1, or changes in the Services must be authorized in writing by the Department or its designated project coordinator prior to such work being performed, or expenses incurred. The Department shall not make payment for any unauthorized work or expenses.

Article 5. Appropriation of Funds Notwithstanding any other provision of this Agreement, if funds for the continued fulfillment of this Agreement by the Department are at any time not forthcoming or are insufficient, through failure of any entity, including the Department itself, to appropriate funds or otherwise, then the Department shall have the right to terminate this Agreement without penalty.

Article 6. Schedule Contractor shall perform the Services according to the following schedule: Services will be on as needed basis upon request of the Department. The time limits established by this schedule shall not be exceeded, except for reasonable cause as mutually agreed to by all parties.

Article 7. Termination In the event of a party's substantial failure to perform in accordance with the terms of this Agreement, the other party shall have the right to terminate the Agreement upon written notice. The nonperforming party shall have fourteen (14) calendar days from the receipt of the termination notice to cure or to submit a plan for cure acceptable to the other party. Additionally, the Department may terminate or suspend performance of this Agreement at the Department's prerogative at any time upon written notice to Contractor. Contractor shall terminate or suspend performance of the Services on a schedule acceptable to the Department and the Department shall pay the Contractor for all the Services performed up to the date that written notice is received, plus reasonable termination or suspension expenses. Upon restart, an equitable adjustment shall be made to Contractor's compensation and the schedule of services. Upon termination or suspension of this Agreement, all finished or unfinished reports, drawings, collections of data and other documents generated by Contractor in connection with this Agreement shall become the property of the Department, as set forth in Article 9 herein.

Article 8. Identity of the Contractor Contractor acknowledges that one of the primary reasons for its selection by the Department to perform the Services is the qualifications and experience of Contractor. Contractor thus agrees that the Services to be performed pursuant to this Agreement shall be performed by Contractor. Contractor shall not subcontract any part of the Services without the prior written permission of the Department. The Department reserves the right to reject any of the Contractor's personnel or proposed outside professional sub-Contractors, and the Department reserves the right to request that acceptable replacement personnel be assigned to the project.

Article 9. Ownership of Documents and Intellectual Property All documents, drawings and specifications, including digital format files, prepared by Contractor and furnished to the Department as part of the Services shall become the property of the Department. Contractor shall retain its ownership rights in its design, drawing details, specifications, databases, computer software and other proprietary property. Intellectual property developed, utilized or modified in the performance of the Services shall remain the property of Contractor.

Article 10. Independent Contractor Status During the entire term of this Agreement, Contractor shall be an independent contractor, and in no event shall any of its personnel, agents or sub-contractors be construed to be, or represent themselves to be, employees of the Department. Contractor shall be solely responsible for the payment and reporting of all employee and employer taxes, including social security, unemployment, and any other federal, state, or local taxes required to be withheld from employees or payable on behalf of employees.

Article 11. Indemnification Contractor shall defend, indemnify, and hold harmless the City of Bloomington, the Department, and the officers, agents and employees of the City and the Department from any and all claims, demands, damages, costs, expenses or other liability arising out of the Agreement or occasioned by the reckless or negligent performance of any provision thereof, including, but not limited to, any reckless or negligent act or failure to act or any misconduct on the part of the Contractor or its agents or employees, or any independent contractors directly responsible to it (collectively "Claims").

Article 12. Insurance During the performance of any and all Services under this Agreement, Contractor shall maintain the following insurance in full force and effect: a) General Liability Insurance, with a

minimum combined single limit of \$1,000,000 for each occurrence and \$2,000,000 in the aggregate; b) Automobile Liability Insurance, with a minimum combined single limit of \$1,000,000 for each person and \$1,000,000 for each accident; c) Workers' Compensation Insurance in accordance with the statutory requirements of Title 22 of the Indiana Code; and d) Professional Liability Insurance ("Errors and Omissions Insurance") with a minimum limit of \$1,000,000 annual aggregate. All insurance policies shall be issued by an insurance company authorized to issue such insurance in the State of Indiana. The City of Bloomington, the Department, and the officers, employees and agents of each shall be named as insureds under the General Liability, Automobile, and Worker's Compensation policies, and such policies shall stipulate that the insurance will operate as primary insurance and that no other insurance of the City's will be called upon to contribute to a loss hereunder. Contractor shall provide evidence of each insurance policy to the Department prior to the commencement of work under this Agreement.

Article 13. Conflict of Interest Contractor declares that it has no present interest, nor shall it acquire any interest, direct or indirect, which would conflict with the performance of Services under this Agreement. Contractor agrees that no person having any such interest shall be employed in the performance of this Agreement.

Article 14. Waiver No failure of either party to enforce a term of this Agreement against the other shall be construed as a waiver of that term, nor shall it in any way affect the party's right to enforce that term. No waiver by any party of any term of this Agreement shall be considered to be a waiver of any other term or breach thereof.

Article 15. Severability The invalidity, illegality or unenforceability of any provision of this Agreement or the occurrence of any event rendering any portion or provision of this Agreement void shall in no way affect the validity or enforceability of any other portion or provision of this Agreement. Any void provision shall be deemed severed from this Agreement, and the balance of the Agreement shall be construed and enforced as if it did not contain the particular provision to be held void. The parties further agree to amend this Agreement to replace any stricken provision with a valid provision that comes as close as possible to the intent of the stricken provision. The provisions of this Article shall not prevent this entire Agreement from being void should a provision which is of the essence of this Agreement be determined void.

Article 16. Assignment Neither the Department nor the Contractor shall assign any rights or duties under this Agreement without the prior written consent of the other party. Unless otherwise stated in the written consent to an assignment, no assignment will release or discharge the assignor from any obligation under this Agreement.

Article 17. Third Party Rights Nothing in this Agreement shall be construed to give any rights or benefits to anyone other than the parties.

Article 18. Governing Law and Venue This Agreement shall be governed by the laws of the State of Indiana. Venue of any disputes arising under this Agreement shall be in the Monroe Circuit Court, Monroe County, Indiana.

Article 19. Non-Discrimination Contractor shall comply with City of Bloomington Ordinance 2.21.020 and all other federal, state and local laws and regulations governing non-discrimination in all regards, including, but not limited to, employment. Contractor understands that the City of Bloomington prohibits its employees from engaging in harassment or discrimination of any kind, including harassing or discriminating against independent contractors doing work for the City. If the Contractor believes that a City employee engaged in such conduct towards Contractor and/or any of its employees, Contractor or its employees may file a complaint with the City department head in charge of the Contractor's work and/or with the City human resources department or the Bloomington Human Rights Commission. The City takes all complaints of harassment and discrimination seriously and will take appropriate disciplinary action if it finds that any City employee engaged in such prohibited conduct.

Article 20. Compliance with Laws In performing the Services under this Agreement, Contractor shall comply with any and all applicable federal, state and local statutes, ordinances, plans and regulations, including any and all regulations for protection of the environment. Where such statutes, ordinances, plans or regulations of any public authority having any jurisdiction over the project are in conflict, Contractor shall proceed using its best judgment only after attempting to resolve any such conflict between such governmental agencies, and shall notify the Department in a timely manner of the conflict, attempts of resolution, and planned course of action.

Article 21. E-Verify Contractor is required to enroll in and verify the work eligibility status of all newly-hired employees through the E-Verify program. (This is not required if the E-Verify program no longer exists). Contractor shall sign an affidavit, attached as Exhibit A, affirming that Contractor does not knowingly employ an unauthorized alien. Contractor shall require any subcontractors performing work under this contract to certify to the Contractor that, at the time of certification, the subcontractor does not knowingly employ or contract with an unauthorized alien and the subcontractor has enrolled in and is participating in the E-Verify program. Contractor shall maintain on file all subcontractors' certifications throughout the term of the contract with the City.

Article 22. Notices Any notice required by this Agreement shall be made in writing to the individuals/addresses specified below:

Department: City of Bloomington Public Works, Attn: J.D. Boruff, 401 N. Morton, Suite 120, Bloomington, Indiana 47404.

Contractor: B & L Sheet Metal and Roofing, 1301 N. Monroe St., Bloomington Indiana 47404.

Nothing contained in this Article shall be construed to restrict the transmission of routine communications between representatives of the Department and Contractor.

Article 23. Integration and Modification This Agreement, including all Exhibits incorporated by reference, represents the entire and integrated agreement between the Department and the Contractor. It supersedes all prior and contemporaneous communications, representations and agreements, whether oral or written, relating to the subject matter of this Agreement. This Agreement may be modified only by a written amendment signed by both parties hereto.

Article 24. Non-Collusion Contractor is required to certify that it has not, nor has any other member, representative, or agent of Contractor, entered into any combination, collusion, or agreement with any person relative to the price to be offered by any person nor prevented any person from making an offer nor induced anyone to refrain from making an offer and that this offer is made without reference to any other offer. Contractor shall sign an affidavit, attached hereto as Exhibit B, affirming that Contractor has not engaged in any collusive conduct. Exhibit B is attached hereto and incorporated by reference as though fully set forth.

Article 25: Renewal This Agreement may be renewed for three additional one-year terms so long as none of the terms and conditions herein are modified in any way. Renewal shall only occur upon advanced written notice by the City to the Contractor that the City wishes to renew the Agreement at least thirty (30) days, but not more than sixty (60) days, prior to the end of the current term

CITY OF BLOOMINGTON

Beth Cate, Corporation Counsel

B & L SHEET METAL AND ROOFING

David Lee, Owner

CITY OF BLOOMINGTON PUBLIC WORKS

Adam Wason, Director

Kyla Cox Deckard, President, Board of Public Works

EXHIBIT B

STATE OF INDIANA)
) SS:
COUNTY OF _____)

NON-COLLUSION AFFIDAVIT

The undersigned offeror or agent, being duly sworn on oath, says that he has not, nor has any other member, representative, or agent of the firm, company, corporation or partnership represented by him, entered into any combination, collusion or agreement with any person relative to the price to be offered by any person nor to prevent any person from making an offer nor to induce anyone to refrain from making an offer and that this offer is made without reference to any other offer.

OATH AND AFFIRMATION

I affirm under the penalties of perjury that the foregoing facts and information are true and correct to the best of my knowledge and belief.

Dated this _____ day of _____, 20____.

B & L Sheet Metal

By: _____

STATE OF INDIANA)
) SS:
COUNTY OF _____)

Before me, a Notary Public in and for said County and State, personally appeared _____ and acknowledged the execution of the foregoing this _____ day of _____, 20____.

Notary Public's Signature My Commission Expires: _____

Printed Name of Notary Public County of Residence: _____

My Commission #: _____



Board of Public Works Staff Report

Project/Event: 2023 Service Agreement with Cassady Electric, Inc. for Electrical Maintenance and Repair Services

Petitioner/Representative: Public Works Facilities Division

Staff Representative: J. D. Boruff, Operations and Facilities Director

Meeting Date: October 25, 2022

This contract is for repair and maintenance of electrical systems at all City facilities maintained by the Public Works Facilities Division through December 31, 2023.

Compensation not to exceed \$55,000.00.

Respectfully submitted,

A handwritten signature in black ink that reads "JD Boruff".

J. D. Boruff
Operations and Facilities Director
Public Works Department

City of Bloomington Contract and Purchase Justification Form

Vendor: Cassady Electric

Contract Amount: \$55,000

This form should be completed and attached to the contract documents and forwarded to the Legal Department Attorney assigned to your Department. Contracts will not be approved by the Controller if a completed form is not included with the contract documents.

PURCHASE INFORMATION

1. Check the box beside the procurement method used to initiate this procurement: (Attach a quote or bid tabulation if applicable)

<input type="checkbox"/> Request for Quote (RFQ)	<input type="checkbox"/> Request for Proposal (RFP)	<input type="checkbox"/> Sole Source	<input type="checkbox"/> Not Applicable (NA)
<input type="checkbox"/> Invitation to Bid (ITB)	<input type="checkbox"/> Request for Qualifications (RFQu)	<input type="checkbox"/> Emergency Purchase	

2. List the results of procurement process. Give further explanation where requested. Yes No

# of Submittals: 0	Yes	No	Was the lowest cost selected? (If no, please state below why it was not.)	Yes	No
Met city requirements?	<input checked="" type="checkbox"/>	<input type="checkbox"/>	We renew a service agreement with Cassady Electric every year.	<input type="checkbox"/>	<input checked="" type="checkbox"/>
Met item or need requirements?	<input checked="" type="checkbox"/>	<input type="checkbox"/>			
Was an evaluation team used?	<input type="checkbox"/>	<input checked="" type="checkbox"/>			
Was scoring grid used?	<input type="checkbox"/>	<input checked="" type="checkbox"/>			
Were vendor presentations requested?	<input type="checkbox"/>	<input checked="" type="checkbox"/>			

3. State why this vendor was selected to receive the award and contract:

We renew a service agreement with Cassady Electric every year.

JD Boruff

Director of Facilities

Public Works

Print/Type Name

Print/Type Title

Department

**AGREEMENT BETWEEN CITY OF BLOOMINGTON
PARKS AND RECREATION DEPARTMENT AND
CASSADY ELECTRICAL CONTRACTORS, INC.**

This Agreement, entered into on this 25th day of October, 2022, by and between the City of Bloomington Department of Public Works (the “Department”), and Cassady Electrical Contractors, Inc. (“Contractor”).

Article 1. Scope of Services Contractor shall perform electrical repair and maintenance services. The Contractor shall furnish all necessary labor and material, on an "on-call" basis, to maintain electrical equipment at various City of Bloomington facilities maintained by the Department of Public Works, Facilities Division. These services will be performed at City facilities for a set price of Ninety- Five Dollars (\$95.00) per hour per person Monday-Friday 7:00am-3:30pm. Any work performed outside of these hours, excluding Sundays and Holidays, will be performed at the rate of One Hundred Forty-Two Dollars and Fifty Cents (\$142.50) per person. Work done at any time on Sundays or Holidays will performed at the rate of One Hundred Ninety Dollars (\$190.00) per hour per person. Contractor shall diligently provide the Services under this Agreement and shall complete the Services described in this Agreement in a timely manner consistent with the Standard of Care identified in Article 2. Contractor shall complete the Services required under this Agreement on or before Thursday, December 31st, 2023, unless the parties mutually agree to a later completion date. Completion shall mean completion of all work related to the Services. In the performance of Contractor’s work, Contractor agrees to maintain such coordination with the Department as may be requested and desirable, including primary coordination with J. D. Boruff, Operations and Facilities Director, Public Works Department. Contractor agrees that any information or documents, including digital GIS information, supplied by the Department pursuant to Article 3, below, shall be used by Contractor for this project only, and shall not be reused or reassigned for any other purpose without the written permission of the Department.

Article 2. Standard of Care Contractor shall be responsible for completion of the Services in a manner consistent with that degree of care and skill ordinarily exercised by members of the same profession currently practicing under similar circumstances (“Standard of Care”). The Department shall be the sole judge of the adequacy of Contractor’s work in meeting the Standard of Care; however, the Department shall not unreasonably withhold its approval as to the adequacy of Contractor’s performance. Upon notice to Contractor and by mutual agreement between the parties, Contractor will, without additional compensation, correct or replace any and all Services not meeting the Standard of Care.

Article 3. Responsibilities of the Department The Department shall provide all necessary information regarding requirements for the Services. The Department shall furnish such information as necessary for the orderly progress of the work, and Contractor shall be entitled to rely upon the accuracy and completeness of such information. The Department’s Project Manager shall act on its behalf with respect to this Agreement.

Article 4. Compensation The Department shall pay Contractor for all fees and expenses in an amount not to exceed Fifty-Five Thousand Dollars (\$55,000.00). Contractor shall submit an invoice to the Department upon the completion of the Services described in Article 1. **Invoices shall be sent via email to public.works@bloomington.in.gov or via first class mail postage prepaid to Public Works Department, 401 N. Morton Street, Suite 120, Bloomington, IN 47404.** Invoices may be sent via first class mail postage prepaid or via email. Payment will be remitted to Contractor within forty-five (45) days of receipt of invoice. Additional services not set forth in Article 1, or changes in the Services must be authorized in writing by the Department or its designated project coordinator prior to such work being performed, or expenses incurred. The Department shall not make payment for any unauthorized work or expenses.

Article 5. Appropriation of Funds Notwithstanding any other provision of this Agreement, if funds for the continued fulfillment of this Agreement by the Department are at any time not forthcoming or are insufficient, through failure of any entity, including the Department itself, to appropriate funds or otherwise, then the Department shall have the right to terminate this Agreement without penalty.

Article 6. Schedule Contractor shall perform the Services according to the following schedule: Services will be on as needed basis upon request of the Department.

Article 7. Termination In the event of a party's substantial failure to perform in accordance with the terms of this Agreement, the other party shall have the right to terminate the Agreement upon written notice. The nonperforming party shall have fourteen (14) calendar days from the receipt of the termination notice to cure or to submit a plan for cure acceptable to the other party. Additionally, the Department may terminate or suspend performance of this Agreement at the Department's prerogative at any time upon written notice to Contractor. Contractor shall terminate or suspend performance of the Services on a schedule acceptable to the Department and the Department shall pay the Contractor for all the Services performed up to the date that written notice is received, plus reasonable termination or suspension expenses. Upon restart, an equitable adjustment shall be made to Contractor's compensation and the schedule of services. Upon termination or suspension of this Agreement, all finished or unfinished reports, drawings, collections of data and other documents generated by Contractor in connection with this Agreement shall become the property of the Department, as set forth in Article 9 herein.

Article 8. Identity of the Contractor Contractor acknowledges that one of the primary reasons for its selection by the Department to perform the Services is the qualifications and experience of Contractor. Contractor thus agrees that the Services to be performed pursuant to this Agreement shall be performed by Contractor. Contractor shall not subcontract any part of the Services without the prior written permission of the Department. The Department reserves the right to reject any of the Contractor's personnel or proposed outside professional sub-Contractors, and the Department reserves the right to request that acceptable replacement personnel be assigned to the project.

Article 9. Ownership of Documents and Intellectual Property All documents, drawings and specifications, including digital format files, prepared by Contractor and furnished to the Department as part of the Services shall become the property of the Department. Contractor shall retain its ownership rights in its design, drawing details, specifications, databases, computer software and other proprietary property. Intellectual property developed, utilized or modified in the performance of the Services shall remain the property of Contractor.

Article 10. Independent Contractor Status During the entire term of this Agreement, Contractor shall be an independent contractor, and in no event shall any of its personnel, agents or sub-contractors be construed to be, or represent themselves to be, employees of the Department. Contractor shall be solely responsible for the payment and reporting of all employee and employer taxes, including social security, unemployment, and any other federal, state, or local taxes required to be withheld from employees or payable on behalf of employees.

Article 11. Indemnification Contractor shall defend, indemnify, and hold harmless the City of Bloomington, the Department, and the officers, agents and employees of the City and the Department from any and all claims, demands, damages, costs, expenses or other liability arising out of the Agreement or occasioned by the reckless or negligent performance of any provision thereof, including, but not limited to, any reckless or negligent act or failure to act or any misconduct on the part of the Contractor or its agents or employees, or any independent contractors directly responsible to it (collectively "Claims").

Article 12. Insurance During the performance of any and all Services under this Agreement, Contractor shall maintain the following insurance in full force and effect: a) General Liability Insurance, with a minimum combined single limit of \$1,000,000 for each occurrence and \$2,000,000 in the aggregate; b) Automobile Liability Insurance, with a minimum combined single limit of \$1,000,000 for each person and \$1,000,000 for each accident; c) Workers' Compensation Insurance in accordance with the statutory requirements of Title 22 of the Indiana Code; and d) Professional Liability Insurance ("Errors and Omissions Insurance") with a minimum limit of \$1,000,000 annual aggregate. All insurance policies shall be issued by an insurance company authorized to issue such insurance in the State of Indiana. The City of Bloomington, the Department, and the officers, employees and agents of each shall be named as insureds under the General Liability, Automobile, and Worker's Compensation policies, and such policies shall stipulate that the insurance will operate as primary insurance and that no other insurance of the City's will be called upon to contribute to a loss hereunder. Contractor shall provide evidence of each insurance policy to the Department prior to the commencement of work under this Agreement.

Article 13. Conflict of Interest Contractor declares that it has no present interest, nor shall it acquire any interest, direct or indirect, which would conflict with the performance of Services under this Agreement. Contractor agrees that no person having any such interest shall be employed in the performance of this Agreement.

Article 14. Waiver No failure of either party to enforce a term of this Agreement against the other shall be construed as a waiver of that term, nor shall it in any way affect the party's right to enforce that term. No waiver by any party of any term of this Agreement shall be considered to be a waiver of any other term or breach thereof.

Article 15. Severability The invalidity, illegality or unenforceability of any provision of this Agreement or the occurrence of any event rendering any portion or provision of this Agreement void shall in no way affect the validity or enforceability of any other portion or provision of this Agreement. Any void provision shall be deemed severed from this Agreement, and the balance of the Agreement shall be construed and enforced as if it did not contain the particular provision to be held void. The parties further agree to amend this Agreement to replace any stricken provision with a valid provision that comes as close as possible to the intent of the stricken provision. The provisions of this Article shall not prevent this entire Agreement from being void should a provision which is of the essence of this Agreement be determined void.

Article 16. Assignment Neither the Department nor the Contractor shall assign any rights or duties under this Agreement without the prior written consent of the other party. Unless otherwise stated in the written consent to an assignment, no assignment will release or discharge the assignor from any obligation under this Agreement.

Article 17. Third Party Rights Nothing in this Agreement shall be construed to give any rights or benefits to anyone other than the parties.

Article 18. Governing Law and Venue This Agreement shall be governed by the laws of the State of Indiana. Venue of any disputes arising under this Agreement shall be in the Monroe Circuit Court, Monroe County, Indiana.

Article 19. Non-Discrimination Contractor shall comply with City of Bloomington Ordinance 2.21.020 and all other federal, state and local laws and regulations governing non-discrimination in all regards, including, but not limited to, employment.

Article 20. Compliance with Laws In performing the Services under this Agreement, Contractor shall comply with any and all applicable federal, state and local statutes, ordinances, plans and regulations, including any and all regulations for protection of the environment. Where such statutes, ordinances, plans or regulations of any public authority having any jurisdiction over the project are in conflict, Contractor

shall proceed using its best judgment only after attempting to resolve any such conflict between such governmental agencies, and shall notify the Department in a timely manner of the conflict, attempts of resolution, and planned course of action.

Article 21. E-Verify Contractor is required to enroll in and verify the work eligibility status of all newly-hired employees through the E-Verify program. (This is not required if the E-Verify program no longer exists). Contractor shall sign an affidavit, attached as Exhibit A, affirming that Contractor does not knowingly employ an unauthorized alien. Contractor shall require any subcontractors performing work under this contract to certify to the Contractor that, at the time of certification, the subcontractor does not knowingly employ or contract with an unauthorized alien and the subcontractor has enrolled in and is participating in the E-Verify program. Contractor shall maintain on file all subcontractors' certifications throughout the term of the contract with the City.

Article 22. Notices Any notice required by this Agreement shall be made in writing to the individuals/addresses specified below:

Department: City of Bloomington Public Works, Attn: J.D. Boruff, 401 N. Morton, Suite 120, Bloomington, Indiana 47404. **Contractor:** Cassady Electric, P.O. Box 53, Ellettsville, Indiana 47429. Nothing contained in this Article shall be construed to restrict the transmission of routine communications between representatives of the Department and Contractor.

Article 23. Integration and Modification This Agreement, including all Exhibits incorporated by reference, represents the entire and integrated agreement between the Department and the Contractor. It supersedes all prior and contemporaneous communications, representations and agreements, whether oral or written, relating to the subject matter of this Agreement. This Agreement may be modified only by a written amendment signed by both parties hereto.

Article 24. Non-Collusion Contractor is required to certify that it has not, nor has any other member, representative, or agent of Contractor, entered into any combination, collusion, or agreement with any person relative to the price to be offered by any person nor prevented any person from making an offer nor induced anyone to refrain from making an offer and that this offer is made without reference to any other offer. Contractor shall sign an affidavit, attached hereto as Exhibit B, affirming that Contractor has not engaged in any collusive conduct. Exhibit B is attached hereto and incorporated by reference as though fully set forth.

Article 25: Renewal This Agreement may be renewed for three additional one-year terms so long as none of the terms and conditions herein are modified in any way. Renewal shall only occur upon advanced written notice by the City to the Contractor that the City wishes to renew the Agreement at least thirty (30) days, but not more than sixty (60) days, prior to the end of the current term

CITY OF BLOOMINGTON

Cassady Electric, Inc.

John Hamilton, Mayor

CITY OF BLOOMINGTON PUBLIC WORKS

Adam Wason, Director

Kyla Cox Deckard, President, Board of Public Works

EXHIBIT B

STATE OF _____)
) SS:
COUNTY OF _____)

NON-COLLUSION AFFIDAVIT

The undersigned offeror or agent, being duly sworn on oath, says that he has not, nor has any other member, representative, or agent of the firm, company, corporation or partnership represented by him, entered into any combination, collusion or agreement with any person relative to the price to be offered by any person nor to prevent any person from making an offer nor to induce anyone to refrain from making an offer and that this offer is made without reference to any other offer.

OATH AND AFFIRMATION

I affirm under the penalties of perjury that the foregoing facts and information are true and correct to the best of my knowledge and belief.

Dated this _____ day of _____, 20__.

Cassady Electric, Inc.

By: _____

STATE OF _____)
) SS:
COUNTY OF _____)

Before me, a Notary Public in and for said County and State, personally appeared _____ and acknowledged the execution of the foregoing this _____ day of _____, 20__.

Notary Public's Signature My Commission Expires: _____

Printed Name of Notary Public County of Residence: _____

My Commission #: _____



Board of Public Works Staff Report

Project/Event: 2023 Service Agreement with City Lawn, LLC for Mowing, Vegetation Removal and Turf Maintenance Services

Petitioner/Representative: Public Works Facilities Division

Staff Representative: J. D. Boruff, Operations and Facilities Director

Meeting Date: October 25, 2022

This contract is for mowing, vegetation removal, and turf maintenance, and snow removal services at City facilities maintained by the Public Works Facilities Division.

Compensation not to exceed \$20,000.00.

Respectfully submitted,

A handwritten signature in black ink that reads "JD Boruff". The signature is written in a cursive, slightly stylized font.

J. D. Boruff
Operations and Facilities Director
Public Works Department

City of Bloomington Contract and Purchase Justification Form

Vendor: City Lawn, LLC

Contract Amount: \$20,000

This form should be completed and attached to the contract documents and forwarded to the Legal Department Attorney assigned to your Department. Contracts will not be approved by the Controller if a completed form is not included with the contract documents.

PURCHASE INFORMATION

1. Check the box beside the procurement method used to initiate this procurement: (Attach a quote or bid tabulation if applicable)

<input type="checkbox"/> Request for Quote (RFQ)	<input type="checkbox"/> Request for Proposal (RFP)	<input type="checkbox"/> Sole Source	<input checked="" type="checkbox"/> Not Applicable (NA)
<input type="checkbox"/> Invitation to Bid (ITB)	<input type="checkbox"/> Request for Qualifications (RFQu)	<input type="checkbox"/> Emergency Purchase	

2. List the results of procurement process. Give further explanation where requested.

of Submittals: 0

	Yes	No
Met city requirements?	<input checked="" type="checkbox"/>	<input type="checkbox"/>
Met item or need requirements?	<input checked="" type="checkbox"/>	<input type="checkbox"/>
Was an evaluation team used?	<input type="checkbox"/>	<input checked="" type="checkbox"/>
Was scoring grid used?	<input type="checkbox"/>	<input checked="" type="checkbox"/>
Were vendor presentations requested?	<input type="checkbox"/>	<input checked="" type="checkbox"/>

Was the lowest cost selected? (If no, please state below why it was not.)

Yes	No
<input type="checkbox"/>	<input checked="" type="checkbox"/>

We renew our service agreement with City Lawn every year.

3. State why this vendor was selected to receive the award and contract:

We renew our service agreement with City Lawn every year.

 JD Boruff

Print/Type Name

 Director of Facilities

Print/Type Title

 Public Works

Department

**AGREEMENT BETWEEN CITY OF BLOOMINGTON
PUBLIC WORKS DEPARTMENT AND
CITY LAWN, LLC**

This Agreement, entered into on this 25th day of October, 2022, by and between the City of Bloomington Department of Public Works (the “Department”), and City Lawn, LLC (“Contractor”).

Article 1. Scope of Services Contractor shall perform repair and maintenance services of the following types: Mowing, vegetation removal, turf treatments and fertilizing. These services will be performed at City facilities (“Services”) for a set price of Fifty Dollars (\$50.00) per person, per hour. This rate shall include any trip charges and/or fuel charges. Costs for materials, such as fertilizer, mulch, or chemical treatments shall be paid by the Department. Contractor shall diligently provide the Services under this Agreement and shall complete the Services described in this Agreement in a timely manner consistent with the Standard of Care identified in Article 2. Contractor shall complete the Services required under this Agreement on or before December 31st, 2023, unless the parties mutually agree to a later completion date. Completion shall mean completion of all work related to the Services. In the performance of Contractor’s work, Contractor agrees to maintain such coordination with the Department as may be requested and desirable, including primary coordination with J. D. Boruff, Operations and Facilities Director, Public Works Department. Contractor agrees that any information or documents, including digital GIS information, supplied by the Department pursuant to Article 3, below, shall be used by Contractor for this project only, and shall not be reused or reassigned for any other purpose without the written permission of the Department.

Article 2. Standard of Care Contractor shall be responsible for completion of the Services in a manner consistent with that degree of care and skill ordinarily exercised by members of the same profession currently practicing under similar circumstances (“Standard of Care”). The Department shall be the sole judge of the adequacy of Contractor’s work in meeting the Standard of Care; however, the Department shall not unreasonably withhold its approval as to the adequacy of Contractor’s performance. Upon notice to Contractor and by mutual agreement between the parties, Contractor will, without additional compensation, correct or replace any and all Services not meeting the Standard of Care.

Article 3. Responsibilities of the Department The Department shall provide all necessary information regarding requirements for the Services. The Department shall furnish such information as necessary for the orderly progress of the work, and Contractor shall be entitled to rely upon the accuracy and completeness of such information. The Department’s Project Manager shall act on its behalf with respect to this Agreement.

Article 4. Compensation The Department shall pay Contractor for all fees and expenses in an amount not to exceed Twenty Thousand Dollars (\$20,000.00). Contractor shall submit an invoice to the Department upon the completion of the Services described in Article 1. **Invoices shall be sent via email to public.works@bloomington.in.gov or via first class mail postage prepaid to Public Works Department, 401 N. Morton Street, Suite 120, Bloomington, IN 47404.** Invoices may be sent via first class mail postage prepaid or via email. Payment will be remitted to Contractor within forty-five (45) days of receipt of invoice. Additional services not set forth in Article 1, or changes in the Services must be authorized in writing by the Department or its designated project coordinator prior to such work being performed, or expenses incurred. The Department shall not make payment for any unauthorized work or expenses.

Article 5. Appropriation of Funds Notwithstanding any other provision of this Agreement, if funds for the continued fulfillment of this Agreement by the Department are at any time not forthcoming or are insufficient, through failure of any entity, including the Department itself, to appropriate funds or otherwise, then the Department shall have the right to terminate this Agreement without penalty.

Article 6. Schedule Contractor shall perform the Services according to the following schedule: Services will be on as needed basis upon request of the Department. The time limits established by this schedule shall not be exceeded, except for reasonable cause as mutually agreed to by all parties.

Article 7. Termination In the event of a party's substantial failure to perform in accordance with the terms of this Agreement, the other party shall have the right to terminate the Agreement upon written notice. The nonperforming party shall have fourteen (14) calendar days from the receipt of the termination notice to cure or to submit a plan for cure acceptable to the other party. Additionally, the Department may terminate or suspend performance of this Agreement at the Department's prerogative at any time upon written notice to Contractor. Contractor shall terminate or suspend performance of the Services on a schedule acceptable to the Department and the Department shall pay the Contractor for all the Services performed up to the date that written notice is received, plus reasonable termination or suspension expenses. Upon restart, an equitable adjustment shall be made to Contractor's compensation and the schedule of services. Upon termination or suspension of this Agreement, all finished or unfinished reports, drawings, collections of data and other documents generated by Contractor in connection with this Agreement shall become the property of the Department, as set forth in Article 9 herein.

Article 8. Identity of the Contractor Contractor acknowledges that one of the primary reasons for its selection by the Department to perform the Services is the qualifications and experience of Contractor. Contractor thus agrees that the Services to be performed pursuant to this Agreement shall be performed by Contractor. Contractor shall not subcontract any part of the Services without the prior written permission of the Department. The Department reserves the right to reject any of the Contractor's personnel or proposed outside professional sub-Contractors, and the Department reserves the right to request that acceptable replacement personnel be assigned to the project.

Article 9. Ownership of Documents and Intellectual Property All documents, drawings and specifications, including digital format files, prepared by Contractor and furnished to the Department as part of the Services shall become the property of the Department. Contractor shall retain its ownership rights in its design, drawing details, specifications, databases, computer software and other proprietary property. Intellectual property developed, utilized or modified in the performance of the Services shall remain the property of Contractor.

Article 10. Independent Contractor Status During the entire term of this Agreement, Contractor shall be an independent contractor, and in no event shall any of its personnel, agents or sub-contractors be construed to be, or represent themselves to be, employees of the Department. Contractor shall be solely responsible for the payment and reporting of all employee and employer taxes, including social security, unemployment, and any other federal, state, or local taxes required to be withheld from employees or payable on behalf of employees.

Article 11. Indemnification Contractor shall defend, indemnify, and hold harmless the City of Bloomington, the Department, and the officers, agents and employees of the City and the Department from any and all claims, demands, damages, costs, expenses or other liability arising out of the Agreement or occasioned by the reckless or negligent performance of any provision thereof, including, but not limited to, any reckless or negligent act or failure to act or any misconduct on the part of the Contractor or its agents or employees, or any independent contractors directly responsible to it (collectively "Claims").

Article 12. Insurance During the performance of any and all Services under this Agreement, Contractor shall maintain the following insurance in full force and effect: a) General Liability Insurance, with a minimum combined single limit of \$1,000,000 for each occurrence and \$2,000,000 in the aggregate; b) Automobile Liability Insurance, with a minimum combined single limit of \$1,000,000 for each person and \$1,000,000 for each accident; c) Workers' Compensation Insurance in accordance with the statutory requirements of Title 22 of the Indiana Code; and d) Professional Liability Insurance ("Errors and Omissions Insurance") with a minimum limit of \$1,000,000 annual aggregate. All insurance policies shall

be issued by an insurance company authorized to issue such insurance in the State of Indiana. The City of Bloomington, the Department, and the officers, employees and agents of each shall be named as insureds under the General Liability, Automobile, and Worker's Compensation policies, and such policies shall stipulate that the insurance will operate as primary insurance and that no other insurance of the City's will be called upon to contribute to a loss hereunder. Contractor shall provide evidence of each insurance policy to the Department prior to the commencement of work under this Agreement.

Article 13. Conflict of Interest Contractor declares that it has no present interest, nor shall it acquire any interest, direct or indirect, which would conflict with the performance of Services under this Agreement. Contractor agrees that no person having any such interest shall be employed in the performance of this Agreement.

Article 14. Waiver No failure of either party to enforce a term of this Agreement against the other shall be construed as a waiver of that term, nor shall it in any way affect the party's right to enforce that term. No waiver by any party of any term of this Agreement shall be considered to be a waiver of any other term or breach thereof.

Article 15. Severability The invalidity, illegality or unenforceability of any provision of this Agreement or the occurrence of any event rendering any portion or provision of this Agreement void shall in no way affect the validity or enforceability of any other portion or provision of this Agreement. Any void provision shall be deemed severed from this Agreement, and the balance of the Agreement shall be construed and enforced as if it did not contain the particular provision to be held void. The parties further agree to amend this Agreement to replace any stricken provision with a valid provision that comes as close as possible to the intent of the stricken provision. The provisions of this Article shall not prevent this entire Agreement from being void should a provision which is of the essence of this Agreement be determined void.

Article 16. Assignment Neither the Department nor the Contractor shall assign any rights or duties under this Agreement without the prior written consent of the other party. Unless otherwise stated in the written consent to an assignment, no assignment will release or discharge the assignor from any obligation under this Agreement.

Article 17. Third Party Rights Nothing in this Agreement shall be construed to give any rights or benefits to anyone other than the parties.

Article 18. Governing Law and Venue This Agreement shall be governed by the laws of the State of Indiana. Venue of any disputes arising under this Agreement shall be in the Monroe Circuit Court, Monroe County, Indiana.

Article 19. Non-Discrimination Contractor shall comply with City of Bloomington Ordinance 2.21.020 and all other federal, state and local laws and regulations governing non-discrimination in all regards, including, but not limited to, employment.

Article 20. Compliance with Laws In performing the Services under this Agreement, Contractor shall comply with any and all applicable federal, state and local statutes, ordinances, plans and regulations, including any and all regulations for protection of the environment. Where such statutes, ordinances, plans or regulations of any public authority having any jurisdiction over the project are in conflict, Contractor shall proceed using its best judgment only after attempting to resolve any such conflict between such governmental agencies, and shall notify the Department in a timely manner of the conflict, attempts of resolution, and planned course of action.

Article 21. E-Verify Contractor is required to enroll in and verify the work eligibility status of all newly-hired employees through the E-Verify program. (This is not required if the E-Verify program no longer exists). Contractor shall sign an affidavit, attached as Exhibit A, affirming that Contractor does not

knowingly employ an unauthorized alien. Contractor shall require any subcontractors performing work under this contract to certify to the Contractor that, at the time of certification, the subcontractor does not knowingly employ or contract with an unauthorized alien and the subcontractor has enrolled in and is participating in the E-Verify program. Contractor shall maintain on file all subcontractors' certifications throughout the term of the contract with the City.

Article 22. Notices Any notice required by this Agreement shall be made in writing to the individuals/addresses specified below:

Department: City of Bloomington Public Works, Attn: J.D. Boruff, 401 N. Morton, Suite 120, Bloomington, Indiana 47404.

Contractor: City Lawn, LLC, PO Box 5561, Bloomington Indiana 47407.

Nothing contained in this Article shall be construed to restrict the transmission of routine communications between representatives of the Department and Contractor.

Article 23. Integration and Modification This Agreement, including all Exhibits incorporated by reference, represents the entire and integrated agreement between the Department and the Contractor. It supersedes all prior and contemporaneous communications, representations and agreements, whether oral or written, relating to the subject matter of this Agreement. This Agreement may be modified only by a written amendment signed by both parties hereto.

Article 24. Non-Collusion Contractor is required to certify that it has not, nor has any other member, representative, or agent of Contractor, entered into any combination, collusion, or agreement with any person relative to the price to be offered by any person nor prevented any person from making an offer nor induced anyone to refrain from making an offer and that this offer is made without reference to any other offer. Contractor shall sign an affidavit, attached hereto as Exhibit B, affirming that Contractor has not engaged in any collusive conduct. Exhibit B is attached hereto and incorporated by reference as though fully set forth.

Article 25: Renewal This Agreement may be renewed for three additional one-year terms so long as none of the terms and conditions herein are modified in any way. Renewal shall only occur upon advanced written notice by the City to the Contractor that the City wishes to renew the Agreement at least thirty (30) days, but not more than sixty (60) days, prior to the end of the current term

CITY OF BLOOMINGTON

John Hamilton, Mayor

City Lawn, LLC

Randy Younger, Owner

CITY OF BLOOMINGTON PUBLIC WORKS

Adam Wason, Director

Kyla Cox Deckard, President, Board of Public Works

EXHIBIT B

STATE OF INDIANA)
) SS:
COUNTY OF _____)

NON-COLLUSION AFFIDAVIT

The undersigned offeror or agent, being duly sworn on oath, says that he has not, nor has any other member, representative, or agent of the firm, company, corporation or partnership represented by him, entered into any combination, collusion or agreement with any person relative to the price to be offered by any person nor to prevent any person from making an offer nor to induce anyone to refrain from making an offer and that this offer is made without reference to any other offer.

OATH AND AFFIRMATION

I affirm under the penalties of perjury that the foregoing facts and information are true and correct to the best of my knowledge and belief.

Dated this _____ day of _____, 2022.

City Lawn, LLC

By: _____

STATE OF INDIANA)
) SS:
COUNTY OF _____)

Before me, a Notary Public in and for said County and State, personally appeared _____ and acknowledged the execution of the foregoing this _____ day of _____, 2022.

Notary Public's Signature My Commission Expires: _____

Printed Name of Notary Public County of Residence: _____

My Commission #: _____



Board of Public Works Staff Report

Project/Event: 2023 Koorsen Fire Protection Monitoring
Petitioner/Representative: Public Works
Staff Representative: JD Boruff
Date: 10.25.2022

Report:

We are requesting a service agreement with Koorsen Fire and Security to perform Fire Alarm Monitoring, Inspection, and Repair Services for the following locations: City Hall (Showers Building), City Parking Garages (4th, Morton, Walnut, Trades), Fleet Services, Bloomington Animal Shelter, Bloomington Street Department, Bloomington Police Firing Range, City of Bloomington Police Department, City of Bloomington Sanitation, Bloomington Fire Department #2, and the Monroe County Dispatch Center and any other Public Works Facilities, as needed.

This contract is for fire alarm monitoring and inspection services.

Total cost = \$30,000

City of Bloomington Contract and Purchase Justification Form

Vendor: Koorsen Fire and Security

Contract Amount: \$30,000

This form should be completed and attached to the contract documents and forwarded to the Legal Department Attorney assigned to your Department. Contracts will not be approved by the Controller if a completed form is not included with the contract documents.

PURCHASE INFORMATION

1. Check the box beside the procurement method used to initiate this procurement: (Attach a quote or bid tabulation if applicable)

<input type="checkbox"/> Request for Quote (RFQ)	<input type="checkbox"/> Request for Proposal (RFP)	<input type="checkbox"/> Sole Source	<input checked="" type="checkbox"/> Not Applicable (NA)
<input type="checkbox"/> Invitation to Bid (ITB)	<input type="checkbox"/> Request for Qualifications (RFQu)	<input type="checkbox"/> Emergency Purchase	

2. List the results of procurement process. Give further explanation where requested.

	Yes	No	
# of Submittals:			Was the lowest cost selected? (If no, please state below why it was not.)
Met city requirements?	<input checked="" type="checkbox"/>	<input type="checkbox"/>	<input checked="" type="checkbox"/> Yes <input type="checkbox"/> No
Met item or need requirements?	<input checked="" type="checkbox"/>	<input type="checkbox"/>	Current vendor for all fire inspection systems
Was an evaluation team used?	<input type="checkbox"/>	<input checked="" type="checkbox"/>	
Was scoring grid used?	<input type="checkbox"/>	<input checked="" type="checkbox"/>	
Were vendor presentations requested?	<input type="checkbox"/>	<input checked="" type="checkbox"/>	

3. State why this vendor was selected to receive the award and contract:

Current vendor for all fire inspection systems

JD Boruff

Print/Type Name

Facilities Director

Print/Type Title

Public Works

Department

**AGREEMENT BETWEEN THE CITY OF BLOOMINGTON
PUBLIC WORKS DEPARTMENT AND
KOORSEN FIRE AND SECURITY**

This Agreement, entered into on this 25th day of October, 2022, by and between the City of Bloomington Department of Public Works (the “Department”), and Koorsen Fire and Security (“Contractor”).

Article 1. Scope of Services After receiving a **Notice to Proceed**, Contractor shall perform repair and maintenance services of the following types: Fire Alarm Monitoring, Inspection, and Repair Services for the following locations: City Hall (Showers Building), City Parking Garages (4th, Morton, Walnut, Trades), Fleet Services, Bloomington Animal Shelter, Bloomington Street Department, Bloomington Police Firing Range, City of Bloomington Police Department, City of Bloomington Sanitation, Bloomington Fire Department #2, Monroe County Dispatch Center, and any other Public Works Facilities, as needed (“Services”), with a set price of Thirty Thousand Dollars (\$30,000). Contractor shall diligently provide the Services under this Agreement and shall complete the Services described in this Agreement in a timely manner consistent with the Standard of Care identified in Article 2. Contractor shall complete the Services required under this Agreement on or before December 31, 2023, unless the parties mutually agree to a later completion date. Completion shall mean completion of all work related to the Services. In the performance of Contractor’s work, Contractor agrees to maintain such coordination with the Department as may be requested and desirable, including primary coordination with J.D. Boruff, Facilities Manager, Public Works Department. Contractor agrees that any information or documents, including digital GIS information, supplied by the Department pursuant to Article 3, below, shall be used by Contractor for this project only, and shall not be reused or reassigned for any other purpose without the written permission of the Department.

Article 2. Standard of Care Contractor shall be responsible for completion of the Services in a manner consistent with that degree of care and skill ordinarily exercised by members of the same profession currently practicing under similar circumstances (“Standard of Care”). The Department shall be the sole judge of the adequacy of Contractor’s work in meeting the Standard of Care; however, the Department shall not unreasonably withhold its approval as to the adequacy of Contractor’s performance. Upon notice to Contractor and by mutual agreement between the parties, Contractor will, without additional compensation, correct or replace any and all Services not meeting the Standard of Care.

Article 3. Responsibilities of the Department The Department shall provide all necessary information regarding requirements for the Services. The Department shall furnish such information as necessary for the orderly progress of the work, and Contractor shall be entitled to rely upon the accuracy and completeness of such information. The Department’s Project Manager shall act on its behalf with respect to this Agreement.

Article 4. Compensation The Department shall pay Contractor for all fees and expenses in an amount not to exceed Thirty Thousand Dollars (\$30,000). Contractor shall submit an invoice to the Department upon the completion of the Services described in Article 1. **Invoices shall be sent via email to public.works@bloomington.in.gov or via first class mail postage prepaid to Public Works Department, 401 N. Morton Street, Suite 120, Bloomington, IN 47404.** Payment will be remitted to Contractor within forty-five (45) days of receipt of invoice. Additional services not set forth in Article 1, or changes in the Services must be authorized in writing by the Department or its designated project coordinator prior to such work being performed, or expenses incurred. The Department shall not make payment for any unauthorized work or expenses.

Article 5. Appropriation of Funds Notwithstanding any other provision of this Agreement, if funds for the continued fulfillment of this Agreement by the Department are at any time not forthcoming or are insufficient, through failure of any entity, including the Department itself, to appropriate funds or otherwise, then the Department shall have the right to terminate this Agreement without penalty.

Article 6. Schedule Contractor shall perform the Services according to the following schedule: Services will be on as needed basis upon request of the Department. The time limits established by this schedule shall not be exceeded, except for reasonable cause as mutually agreed to by all parties.

Article 7. Termination In the event of a party's substantial failure to perform in accordance with the terms of this Agreement, the other party shall have the right to terminate the Agreement upon written notice. The nonperforming party shall have fourteen (14) calendar days from the receipt of the termination notice to cure or to submit a plan for cure acceptable to the other party. Additionally, the Department may terminate or suspend performance of this Agreement at the Department's prerogative at any time upon written notice to Contractor. Contractor shall terminate or suspend performance of the Services on a schedule acceptable to the Department and the Department shall pay the Contractor for all the Services performed up to the date that written notice is received, plus reasonable termination or suspension expenses. Upon restart, an equitable adjustment shall be made to Contractor's compensation and the schedule of services. Upon termination or suspension of this Agreement, all finished or unfinished reports, drawings, collections of data and other documents generated by Contractor in connection with this Agreement shall become the property of the Department, as set forth in Article 9 herein.

Article 8. Identity of the Contractor Contractor acknowledges that one of the primary reasons for its selection by the Department to perform the Services is the qualifications and experience of Contractor. Contractor thus agrees that the Services to be performed pursuant to this Agreement shall be performed by Contractor. Contractor shall not subcontract any part of the Services without the prior written permission of the Department. The Department reserves the right to reject any of the Contractor's personnel or proposed outside professional sub-Contractors, and the Department reserves the right to request that acceptable replacement personnel be assigned to the project.

Article 9. Ownership of Documents and Intellectual Property All documents, drawings and specifications, including digital format files, prepared by Contractor and furnished to the Department as part of the Services shall become the property of the Department. Contractor shall retain its ownership rights in its design, drawing details, specifications, databases, computer software and other proprietary property. Intellectual property developed, utilized or modified in the performance of the Services shall remain the property of Contractor.

Article 10. Independent Contractor Status During the entire term of this Agreement, Contractor shall be an independent contractor, and in no event shall any of its personnel, agents or sub-contractors be construed to be, or represent themselves to be, employees of the Department. Contractor shall be solely responsible for the payment and reporting of all employee and employer taxes, including social security, unemployment, and any other federal, state, or local taxes required to be withheld from employees or payable on behalf of employees.

Article 11. Indemnification Contractor shall indemnify and hold harmless the City of Bloomington, the Department, and the officers, agents and employees of the City and the Department from any and all claims, demands, damages, costs, expenses or other liability arising out of the Agreement or occasioned by the reckless or negligent performance of any provision thereof, including, but not limited to, any reckless or negligent act or failure to act or any misconduct on the part of the Contractor or its agents or employees, or any independent contractors directly responsible to it (collectively "Claims").

Article 12. Insurance During the performance of any and all Services under this Agreement, Contractor shall maintain the following insurance in full force and effect: a) General Liability Insurance, with a

minimum combined single limit of \$1,000,000 for each occurrence and \$2,000,000 in the aggregate; b) Automobile Liability Insurance, with a minimum combined single limit of \$1,000,000 for each person and \$1,000,000 for each accident; c) Workers' Compensation Insurance in accordance with the statutory requirements of Title 22 of the Indiana Code; and d) Professional Liability Insurance ("Errors and Omissions Insurance") with a minimum limit of \$1,000,000 annual aggregate. All insurance policies shall be issued by an insurance company authorized to issue such insurance in the State of Indiana. The City of Bloomington, the Department, and the officers, employees and agents of each shall be named as insureds under the General Liability, Automobile, and Worker's Compensation policies, and such policies shall stipulate that the insurance will operate as primary insurance and that no other insurance of the City's will be called upon to contribute to a loss hereunder. Contractor shall provide evidence of each insurance policy to the Department prior to the commencement of work under this Agreement.

Article 13. Conflict of Interest Contractor declares that it has no present interest, nor shall it acquire any interest, direct or indirect, which would conflict with the performance of Services under this Agreement. Contractor agrees that no person having any such interest shall be employed in the performance of this Agreement.

Article 14. Waiver No failure of either party to enforce a term of this Agreement against the other shall be construed as a waiver of that term, nor shall it in any way affect the party's right to enforce that term. No waiver by any party of any term of this Agreement shall be considered to be a waiver of any other term or breach thereof.

Article 15. Severability The invalidity, illegality or unenforceability of any provision of this Agreement or the occurrence of any event rendering any portion or provision of this Agreement void shall in no way affect the validity or enforceability of any other portion or provision of this Agreement. Any void provision shall be deemed severed from this Agreement, and the balance of the Agreement shall be construed and enforced as if it did not contain the particular provision to be held void. The parties further agree to amend this Agreement to replace any stricken provision with a valid provision that comes as close as possible to the intent of the stricken provision. The provisions of this Article shall not prevent this entire Agreement from being void should a provision which is of the essence of this Agreement be determined void.

Article 16. Assignment Neither the Department nor the Contractor shall assign any rights or duties under this Agreement without the prior written consent of the other party. Unless otherwise stated in the written consent to an assignment, no assignment will release or discharge the assignor from any obligation under this Agreement.

Article 17. Third Party Rights Nothing in this Agreement shall be construed to give any rights or benefits to anyone other than the parties.

Article 18. Governing Law and Venue This Agreement shall be governed by the laws of the State of Indiana. Venue of any disputes arising under this Agreement shall be in the Monroe Circuit Court, Monroe County, Indiana.

Article 19. Non-Discrimination Contractor shall comply with City of Bloomington Ordinance 2.21.020 and all other federal, state and local laws and regulations governing non-discrimination in all regards, including, but not limited to, employment. Contractor understands that the City of Bloomington prohibits its employees from engaging in harassment or discrimination of any kind, including harassing or discriminating against independent contractors doing work for the City. If the Contractor believes that a City employee engaged in such conduct towards Contractor and/or any of its employees, Contractor or its employees may file a complaint with the City department head in charge of the Contractor's work and/or with the City human resources department or the Bloomington Human Rights Commission. The City takes all complaints of harassment and discrimination seriously and will take appropriate disciplinary action if it finds that any City employee engaged in such prohibited conduct.

Article 20. Compliance with Laws In performing the Services under this Agreement, Contractor shall comply with any and all applicable federal, state and local statutes, ordinances, plans and regulations, including any and all regulations for protection of the environment. Where such statutes, ordinances, plans or regulations of any public authority having any jurisdiction over the project are in conflict, Contractor shall proceed using its best judgment only after attempting to resolve any such conflict between such governmental agencies, and shall notify the Department in a timely manner of the conflict, attempts of resolution, and planned course of action.

Article 21. E-Verify Contractor is required to enroll in and verify the work eligibility status of all newly-hired employees through the E-Verify program. (This is not required if the E-Verify program no longer exists). Contractor shall sign an affidavit, attached as Exhibit A, affirming that Contractor does not knowingly employ an unauthorized alien. Contractor shall require any subcontractors performing work under this contract to certify to the Contractor that, at the time of certification, the subcontractor does not knowingly employ or contract with an unauthorized alien and the subcontractor has enrolled in and is participating in the E-Verify program. Contractor shall maintain on file all subcontractors' certifications throughout the term of the contract with the City.

Article 22. Notices Any notice required by this Agreement shall be made in writing to the individuals/addresses specified below:

Department: City of Bloomington Public Works, Attn: J.D. Boruff, 401 N. Morton, Suite 120, Bloomington, Indiana 47404.

Contractor: Koorsen Fire and Security, 1131 Air Drive, Bloomington, IN 47403

Nothing contained in this Article shall be construed to restrict the transmission of routine communications between representatives of the Department and Contractor.

Article 23. Integration and Modification This Agreement, including all Exhibits incorporated by reference, represents the entire and integrated agreement between the Department and the Contractor. It supersedes all prior and contemporaneous communications, representations and agreements, whether oral or written, relating to the subject matter of this Agreement. This Agreement may be modified only by a written amendment signed by both parties hereto.

Article 24. Non-Collusion Contractor is required to certify that it has not, nor has any other member, representative, or agent of Contractor, entered into any combination, collusion, or agreement with any person relative to the price to be offered by any person nor prevented any person from making an offer nor induced anyone to refrain from making an offer and that this offer is made without reference to any other offer. Contractor shall sign an affidavit, attached hereto as Exhibit B, affirming that Contractor has not engaged in any collusive conduct. Exhibit B is attached hereto and incorporated by reference as though fully set forth.

Article 25: Renewal This Agreement may be renewed for three additional one-year terms so long as none of the terms and conditions herein are modified in any way. Renewal shall only occur upon advanced written notice by the City to the Contractor that the City wishes to renew the Agreement at least thirty (30) days, but not more than sixty (60) days, prior to the end of the current term.

CITY OF BLOOMINGTON

Koorsen Fire and Security

Beth Cate, Corporation Counsel

John York

CITY OF BLOOMINGTON PUBLIC WORKS

Adam Wason, Director

Kyla Cox Deckard, President, Board of Public Works

EXHIBIT B

STATE OF INDIANA)
) SS:
COUNTY OF _____)

NON-COLLUSION AFFIDAVIT

The undersigned offeror or agent, being duly sworn on oath, says that he has not, nor has any other member, representative, or agent of the firm, company, corporation or partnership represented by him, entered into any combination, collusion or agreement with any person relative to the price to be offered by any person nor to prevent any person from making an offer nor to induce anyone to refrain from making an offer and that this offer is made without reference to any other offer.

OATH AND AFFIRMATION

I affirm under the penalties of perjury that the foregoing facts and information are true and correct to the best of my knowledge and belief.

Dated this _____ day of _____, 20_____.

Koorsen Fire and Security

By: _____

STATE OF INDIANA)
) SS:
COUNTY OF _____)

Before me, a Notary Public in and for said County and State, personally appeared _____ and acknowledged the execution of the foregoing this ____ day of _____, 20____.

Notary Public Printed Name

Notary Public's Signature

My Commission Expires: _____

County of Residence: _____

My Commission #: _____



Board of Public Works Staff Report

Project/Event: Fire Station Air Filtration System Filter Changes

Petitioner/Representative: Department of Public Works, Facilities Division

Staff Representative: J. D. Boruff, Operations and Facilities Director

Meeting Date: October 25, 2022

This is a contract for the replacement of filters in the air filtration units installed in Fire Department facilities. This is a sole source contract due to the fact that Air Technolgy Solutions, LLC is the sole factory representative, they installed the systems originally, and they use original equipment manufacturer filters.

Staff recommends awarding the contract to Air Technolgy Solutions, LLC for \$34,612.66.

Respectfully submitted,

A handwritten signature in black ink that reads "JD Boruff".

J. D. Boruff
Operations and Facilities Director
Public Works Department

City of Bloomington Contract and Purchase Justification Form

Vendor: Air Technology Solutions

Contract Amount: \$34,612.66

This form should be completed and attached to the contract documents and forwarded to the Legal Department Attorney assigned to your Department. Contracts will not be approved by the Controller if a completed form is not included with the contract documents.

PURCHASE INFORMATION

1. Check the box beside the procurement method used to initiate this procurement: (Attach a quote or bid tabulation if applicable)

<input type="checkbox"/> Request for Quote (RFQ)	<input type="checkbox"/> Request for Proposal (RFP)	<input checked="" type="checkbox"/> Sole Source	<input type="checkbox"/> Not Applicable (NA)
<input type="checkbox"/> Invitation to Bid (ITB)	<input type="checkbox"/> Request for Qualifications (RFQu)	<input type="checkbox"/> Emergency Purchase	

2. List the results of procurement process. Give further explanation where requested.

# of Submittals: 1	Yes	No	Was the lowest cost selected? (If no, please state below why it was not.)	Yes	No
Met city requirements?	<input checked="" type="checkbox"/>	<input type="checkbox"/>	This is a sole source purchase based on specific requirements of the air filtration systems installed.	<input type="checkbox"/>	<input checked="" type="checkbox"/>
Met item or need requirements?	<input checked="" type="checkbox"/>	<input type="checkbox"/>			
Was an evaluation team used?	<input type="checkbox"/>	<input checked="" type="checkbox"/>			
Was scoring grid used?	<input type="checkbox"/>	<input checked="" type="checkbox"/>			
Were vendor presentations requested?	<input type="checkbox"/>	<input checked="" type="checkbox"/>			

3. State why this vendor was selected to receive the award and contract:

This vendor was chosen in 2017, with an approved sole source purchase, to install the air filtration systems for all Fire Stations. This is the sole vendor that installs and maintains this particular equipment. The filters they use are original equipment replacement filters. There is no other vendor that has these exact filters, or is a factory service representative for this equipment.

J. D> Boruff

Facilities Director

Public Works

Print/Type Name

Print/Type Title

Department

AGREEMENT

BETWEEN

CITY OF BLOOMINGTON

PUBLIC WORKS DEPARTMENT

AND

AIR TECHNOLOGY SOLUTIONS, LLC

FOR

FILTER CHANGES ON AIR FILTRATION UNITS AT FIRE DEPARTMENT FACILITIES

THIS AGREEMENT, executed by and between the City of Bloomington, Indiana, Public Works Department through the Board of Public Works (hereinafter CITY), and Air Technology Solutions, LLC, (hereinafter CONTRACTOR);

WITNESSETH THAT:

WHEREAS, CITY desires to retain CONTRACTOR'S services for **Filter Changes on Air Filtration Units at Fire Department Facilities**, (more particularly described in Attachment A, "Scope of Work"); and

WHEREAS, CONTRACTOR is capable of performing work as per his/her Quote on the Quote Summary sheet; and

WHEREAS, in accordance with Indiana Code 5-16-13 *et seq.*, incorporated herein by reference, Contractor is a Tier 1 or General Contractor for this project; and

WHEREAS, CONTRACTOR was determined to be the lowest responsible and responsive Quoter for said project.

NOW, THEREFORE, in consideration of the mutual promises hereinafter enumerated, the parties agree as follows:

ARTICLE 1. TERM

1.01 This Agreement shall be in effect upon execution of this Agreement by all parties and shall remain in until December 31, 2026. In accordance with Indiana Code 5-16-13 *et seq.*, incorporated herein by reference, Contractor is a Tier 1 contractor or general contractor for this project.

ARTICLE 2. SERVICES

2.01 CONTRACTOR shall complete all work required under this Agreement during the Term, unless the parties mutually agree to a later completion date. Substantial Completion shall mean completion of all work.

2.02 It is hereby understood by both parties that time is of the essence in this Agreement. Failure of CONTRACTOR to complete all work as herein provided will result in monetary damages to CITY. It is hereby agreed that CITY will be damaged for every day the work has not been performed in the manner herein provided. The CITY, at its sole discretion, may withhold monies otherwise due CONTRACTOR. It is expressly understood by the parties hereto that these damages relate to the time of performance and do not limit CITY's other remedies under this Agreement, or as provided by applicable law, for other damages.

2.03 CONTRACTOR agrees that no charges or claims for damages shall be made by him for any delays or hindrances, from any cause whatsoever during the progress of any portion of the services specified in the Agreement. Such delays or hindrances, if any, may be compensated for by an extension of time for a reasonable period as may be mutually agreed upon between the parties, it being understood, however, that permitting CONTRACTOR to proceed to complete any service, or any

part of the services / project, after the date to which the time of completion may have been extended, shall in no way operate as a waiver on the part of CITY of any of its rights herein.

ARTICLE 3. COMPENSATION

3.01 CONTRACTOR shall provide services as specified in Attachment A, "Scope of Work", attached hereto and incorporated into this Agreement.

3.02 Upon the submittal of approved claims, CITY shall compensate CONTRACTOR in a lump sum not to exceed **Thirty Four Thousand Six Hundred Twelve Dollars and Sixty Six Cents (\$34,612.66)**. CITY may withhold payment, in whole or in part, to the extent necessary to protect itself from a loss on account of any of the following:

Defective work.

Evidence indicating the probable filing of claims by other parties against CONTRACTOR which may adversely affect CITY.

Failure of CONTRACTOR to make payments due to subcontractors, material suppliers or employees.

Damage to CITY or a third party.

3.03 The submission of any request for payment shall be deemed a waiver and release by CONTRACTOR of all liens and claims with respect to the work and period to which such payment request pertains except as specifically reserved and noted on such request.

3.04 CONTRACTOR shall maintain proper account records for the scope of all services of this Agreement and provide an accounting for all charges and expenditures as may be necessary for audit purposes. All such records shall be subject to inspection and examination by CITY's representatives at reasonable business hours.

3.05 For projects utilizing federal funding the CONTRACTOR shall submit time sheets (WH-347) for his own and all subcontracted employees, to City Engineer or his representative for approval and review, including review for compliance with Davis Bacon requirements, if federal funds are used.

3.06 **Engineer** The City Engineer shall act as the CITY's representative and assume all duties and responsibilities and have all the rights and authority assigned to the Engineer in the Contract Documents in connection with completion of the Work in accordance with the Contract Documents.

ARTICLE 4. RETAINAGE

For contracts in excess of \$100,000 and for which Contractor requested Progressive Payments on its Quote Form, the Owner requires that retainage be held set out below.

4.01 **Escrow Agent** The retainage amount withheld shall be placed in an escrow account. First Financial Bank, Bloomington, Indiana, shall serve as the escrow agent.

4.02 **Retainage Amount** The escrow agent, Owner and Contractor shall enter into a written escrow agreement. Under that agreement, the Owner shall withhold five percent (5%) of the dollar value of all work satisfactorily completed until the Contract work is complete. The escrow agent shall invest all escrowed principal in obligations selected by the escrow agent. The escrow agent shall be compensated for the agent's services by a reasonable fee, agreed upon by the parties, that is comparable with fees charged for the handling of escrow accounts of similar size and duration. The fee shall be paid from the escrow income. The escrow agent's fee may be determined by specifying an amount of interest the escrow agent will pay on the escrowed amount, with any additional earned interest serving as the escrow agent's fee. The escrow agreement may include other terms and conditions as deemed necessary by the parties. However, if Contractor intends to receive a Single Lump Sum payment upon acceptance of this project, retainage will not be required and an Escrow Agreement will not be required.

4.03 **Payment of Escrow Amount** The escrow agent shall hold the escrowed principal and income until receipt of the notice from the Owner and Contractor that the Contract work has been substantially completed to the reasonable satisfaction of the Owner, at which time the Owner shall pay to the Contractor the balance to be paid under this Contract and execute such documents as are necessary to authorize the escrow agent to pay to the Contractor the funds in the

escrow account, including both specifying the part of the escrowed principal to be released from the escrow and the person to whom that portion is to be released. After receipt of the notice, the escrow agent shall remit the designated part of the escrowed principal and the escrowed income, minus the escrow agent's fees, to the person specified in the notice. However, nothing in this section shall prohibit Owner from requiring the escrow agent to withhold amounts necessary to complete minor items of the Contract, following substantial completion of the Contract in accordance with the provisions of paragraph 4.04.

4.04 Withholding Funds for Completion of Contract If, upon substantial completion of the Contract, there still remains minor Contract work that needs to be completed, or minor Contract work that needs to be performed to the satisfaction of the Owner, Owner may direct the escrow agent to retain in the escrow account, and withhold from payment to the Contractor, an amount equal to two hundred percent (200%) of the value of said work. The value of said work shall be determined by the architect/engineer. The escrow agent shall release the funds withheld under this section after receipt of notice from the Owner that all work on the Contract has been satisfactorily completed. In the event that said work is not completed by the Contractor, but by Owner or another party under contract with the Owner, said funds shall be released to the Owner.

ARTICLE 5. GENERAL PROVISIONS

5.01 CONTRACTOR agrees to indemnify and hold harmless CITY and its officers, agents, officials and employees for any and all claims, actions, causes of action, judgments and liens arising out of any negligent act or omission by CONTRACTOR or any of its officers, agents, officials, employees, or subcontractors or any defect in materials or workmanship of any supply, materials, mechanism or other product or service which it or any of its officers, agents, officials, employees, or subcontractors has supplied to CITY or has used in connection with this Agreement and regardless of whether or not it is caused in part by a party indemnified herein under. Such indemnity shall include attorney's fees and all costs and other expenses arising there from or incurred in connection therewith and shall not be limited by reason of the enumeration of any insurance coverage required herein.

CONTRACTOR shall indemnify and hold harmless CITY and its officers, agents, officials and employees for any and all damages, actions, costs, (including, but not limited to, attorney's fees, court costs and costs of investigation) judgments and claims by anyone for damage to property, injury or death to persons resulting from the collapse or failure of any trenches, ditches or other excavations constructed under or associated with this contract.

5.02 Abandonment, Default and Termination

5.02.01 CITY shall have the right to abandon the work contracted for in this Agreement without penalty. If CITY abandons the work described herein, CONTRACTOR shall deliver to CITY all surveys, notes, drawings, specifications and estimates completed or partially completed and these shall become the property of CITY. The earned value of the work performed shall be based upon an estimate of the proportion between the work performed by CONTRACTOR under this Agreement and the work which CONTRACTOR was obligated to perform under this Agreement. This proportion shall be mutually agreed upon by CITY and CONTRACTOR. The payment made to CONTRACTOR shall be paid as a final payment in full settlement of his services hereunder.

5.02.02 If CONTRACTOR defaults or fails to fulfill in a timely and proper manner the obligations pursuant to this Agreement, CITY may, after seven (7) days' written notice has been delivered to CONTRACTOR, and without prejudice to any other remedy it may have, make good such deficiencies and may deduct the cost thereof from the payment then or thereafter due to CONTRACTOR. In the alternative, CITY, at its option, may terminate this Agreement and take possession of the site and of all materials, equipment, tools and construction equipment and machinery thereon owned by CONTRACTOR, and may finish the project by whatever method it may deem expedient, and if the such action exceeds the unpaid balance of the sum amount, CONTRACTOR or his surety, shall pay the difference to CITY.

5.02.03 Default: If CONTRACTOR breaches this Agreement or fails to perform the work in an acceptable manner, he shall be considered in default. Any one or more of the following will be considered a default:

Failure to begin the work under this Agreement within the time specified.

Failure to perform the work with sufficient supervision, workmen, equipment and materials to insure prompt completion of said work within the time limits allowed.

Unsuitable performance of the work as determined by CITY ENGINEER or his representative.

Neglecting or refusing to remove defective materials or failure to perform anew such work as shall have been rejected.

Discontinuing the prosecution of the work or any part of it.

Inability to finance the work adequately.

If, for any other reason, CONTRACTOR breaches this Agreement or fails to carry on the work in an acceptable manner.

5.02.04 CITY shall send CONTRACTOR a written notice of default. If CONTRACTOR, or his Surety, within a period of ten (10) days after such notice, fails to remedy the default, then CITY shall have full power and authority, without violation of the Contract, to take the prosecution of the work out of the hands of said CONTRACTOR, to appropriate or use any or all materials and equipment on the ground as may be suitable and acceptable, and may, at its option, turn the work over to the Surety, or enter into an agreement with another Contractor for the completion of the Agreement according to the terms and provisions thereof, or CITY may use such other methods as, in its opinion, shall be required for the completion of said Contract in an acceptable manner.

5.02.05 All cost of completing the work under the Contract shall be deducted from the monies due or which may become due to said CONTRACTOR. In case the expenses so incurred by CITY shall be less than the sum which would have been payable under the Contract if it had been completed by said CONTRACTOR, CONTRACTOR shall be entitled to receive the difference. However, in case such expense shall exceed the sum which would have been payable under the Contract, CONTRACTOR and his Surety will be liable and shall pay to CITY the amount of said excess. By taking over the prosecution of the work, CITY does not forfeit the right to recover damages from CONTRACTOR or his Surety for his failure to complete the work in the time specified.

5.02.06 Notwithstanding any other provision of this Agreement, if funds for the continued fulfillment of the Agreement by CITY are at any time not forthcoming or are insufficient, through failure of any entity to appropriate the funds or otherwise, then CITY shall have the right to terminate this Agreement without penalty by giving prior written notice documenting the lack of funding in which instance, unless otherwise agreed to by the parties, this Agreement shall terminate and become null and void.

5.02.07 CITY agrees that it will make its best effort to obtain sufficient funds, including but not limited to, including in its budget for each fiscal period during the term hereof a request for sufficient funds to meet its obligations hereunder in full.

5.03 Successors and Assigns

5.03.01 Both parties agree that for the purpose of this Agreement, CONTRACTOR shall be an Independent Contractor and not an employee of CITY.

5.03.02 No portion of this Agreement shall be sublet, assigned, transferred or otherwise disposed of by CONTRACTOR except with the written consent of CITY being first obtained. Consent to sublet, assign, transfer, or otherwise dispose of any portion of this Agreement shall not be construed to relieve CONTRACTOR of any responsibility of the fulfillment of this Agreement.

5.04 Extent of Agreement: Integration

5.04.01 This Agreement consists of the following parts, each of which is as fully a part of this Agreement as if set out herein:

1. This Agreement and its Attachments.
2. All Written Amendments and other documents amending, modifying, or supplementing the Contract Documents which may be delivered or issued after the Effective Date of the Agreement and are not attached hereto.
3. All Addenda to the Quote Documents.
4. The Invitation to Quoters.
5. The Instructions to Quoters.
6. The Special Conditions.
7. All plans as provided for the work that is to be completed.
8. The Supplementary Conditions.
9. The General Conditions.
10. The Specifications.

11. The current Indiana Department of Transportation Standard Specifications and the latest addenda.
12. CONTRACTOR'S submittals.
13. The Performance Bond and the Payment Bond.
14. The Escrow Agreement.
15. Request for Taxpayer Identification number and certification: Substitute W-9.

5.04.02 In resolving conflicts, errors, discrepancies and disputes concerning the Scope of Work to be performed by CONTRACTOR, and other rights and obligations of CITY and CONTRACTOR, the document expressing the greater quantity, quality or other scope of work in question, or imposing the greater obligation upon CONTRACTOR and affording the greater right or remedy to CITY shall govern; otherwise the documents shall be given precedence in the order as enumerated above.

5.05 Insurance

5.05.01

CONTRACTOR shall, as a prerequisite to this Agreement, purchase and thereafter maintain such insurance as will protect him from the claims set forth below which may arise out of or result from CONTRACTOR'S operations under this Agreement, whether such operations be by CONTRACTOR or by any SUBCONTRACTORS or by anyone directly or indirectly employed by any of them, or by anyone for whose acts any of them may be liable:

<u>Coverage</u>	<u>Limits</u>
A. Worker's Compensation & Disability	Statutory Requirements
B. Employer's Liability Bodily Injury by Accident	\$100,000 each accident
Bodily Injury by Disease	\$500,000 policy limit
Bodily Injury by Disease	\$100,000 each employee
C. Commercial General Liability (Occurrence Basis)	\$1,000,000 per occurrence
Bodily Injury, personal injury, property damage, contractual liability, products-completed operations, General Aggregate Limit (other than Products/Completed Operations)	and \$2,000,000 in the aggregate
Products/Completed Operation	\$1,000,000
Personal & Advertising Injury Limit	\$1,000,000
Each Occurrence Limit	\$1,000,000
Fire Damage (any one fire)	\$50,000
D. Comprehensive Auto Liability (single limit, owned, hired and non-owned)	\$1,000,000 each accident
Bodily injury and property damage	
E. Umbrella Excess Liability	\$5,000,000 each occurrence and aggregate
The Deductible on the Umbrella Liability shall not be more than	\$10,000

5.05.02 CONTRACTOR'S comprehensive general liability insurance shall also provide coverage for the following:

Premises and operations;

Contractual liability insurance as applicable to any hold-harmless agreements;

Completed operations and products; which also must be maintained for a minimum period of two (2) years after final payment and CONTRACTOR shall continue to provide evidence of such coverage to CITY on an annual basis during the aforementioned period;

Broad form property damage - including completed operations;

Fellow employee claims under Personal Injury; and

Independent Contractors.

5.05.03 With the prior written approval of CITY, CONTRACTOR may substitute different types or amounts of coverage for those specified as long as the total amount of required protection is not reduced.

5.05.04 Certificates of Insurance showing such coverage then in force (but not less than the amount shown above) shall be on file with CITY prior to commencement of work. These Certificates shall contain a provision that coverage afforded under the policies will not be canceled or non-renewed until at least sixty (60) days' prior written notice has been received by CITY. The CITY shall be named as an additional insured on the Commercial General Liability, Automobile Liability, and Umbrella Excess Liability policies. The CONTRACTOR shall agree to a waiver of subrogation on its Worker's Compensation policy.

5.06 **Necessary Documentation** CONTRACTOR certifies that it will furnish CITY any and all documentation, certification, authorization, license, permit or registration required by the laws or rules and regulations of the City of Bloomington, the State of Indiana and the United States. CONTRACTOR further certifies that it is now and will maintain in good standing with such governmental agencies and that it will keep its license, permit registration, authorization or certification in force during the term of this Agreement.

5.07 **Applicable Laws** CONTRACTOR agrees to comply with all federal, state, and local laws, rules and regulations applicable to CONTRACTOR in performing work pursuant to this Agreement, including, but not limited to, discrimination in employment, prevailing wage laws, conflicts of interest, public notice, accounting records and requirements. This Agreement shall be governed by the laws of the United States, and the State of Indiana, and by all Municipal Ordinances and Codes of the City of Bloomington. Venue of any disputes arising under this Agreement shall be in the Monroe Circuit Court, Monroe County, Indiana.

5.08 **Non-Discrimination**

5.08.01 CONTRACTOR and subcontractors shall not discriminate against any employee or applicant for employment, to be employed in the performance of this Agreement, with respect to hire, tenure, terms, training, conditions or privileges of employment, because of race, sex, color, religion, national origin, ancestry, disability, sexual orientation, gender identity, veteran status, or housing status.

Contractor shall comply with City of Bloomington Ordinance 2.21.020 and all other federal, state and local laws and regulations governing non-discrimination, including but not limited to employment.

Contractor understands that the City of Bloomington prohibits its employees from engaging in harassment or discrimination of any kind, including harassing or discriminating against independent contractors doing work for the City. If the Contractor believes that a City employee engaged in such conduct towards Contractor and/or any of its employees, Contractor or its employees may file a complaint with the City department head in charge of the Contractor's work and/or with the City human resources department or the Bloomington Human Rights Commission. The City takes all complaints of harassment and discrimination seriously and will take appropriate disciplinary action if it finds that any City employee engaged in such prohibited conduct.

Breach of this covenant may be regarded as a material breach of the Agreement.

5.08.02 CONTRACTOR certifies for itself and all its subcontractors compliance with existing laws of the City of Bloomington, the State of Indiana and the United States regarding:

Prohibition of discrimination in employment practices on the basis of race, sex, color, religion, national origin, ancestry, disability, sexual orientation, gender identity, veteran status, housing status, or any other legally protected classification;

The utilization of Minority and Women Business Enterprises. CONTRACTOR further certifies that it:

- a. Has formulated its own Affirmation Action plan for the recruitment, training and employment of minorities and women, including goals and timetable; which has been approved by the City's Contract Compliance Officer.
- b. Encourages the use of small business, minority-owned business and women-owned business in its operations.

5.08.03 FURTHER, PURSUANT TO INDIANA CODE 5-16-6-1, CONTRACTOR AGREES:

A) That in the hiring of employees for the performance of work under this Agreement or any sub agreement hereunder, no contractor, or subcontractor, nor any person acting on behalf of such CONTRACTOR or subcontractor, shall by reason of race, sex, color, religion, national origin, ancestry, or any other legally protected classification, discriminate against any citizen of the State of Indiana who is qualified and available to perform the work to which the employment relates.

B) That no contractor, subcontractor, or any person on their behalf, shall, in any manner, discriminate against or intimidate any employee hired for performance of work under this Agreement on account of race, religion, color, sex, national origin, ancestry, or any other legally protected classification.

C) That there may be deducted from the amount payable to CONTRACTOR, by CITY, under this Agreement, penalty of Five Dollars (\$5.00) for each person for each calendar day during which such person was discriminated against or intimidated in violation of the provisions of this Agreement. Any such person discriminated against retains the right to file a discrimination complaint with the appropriate civil rights agency or court.

D) That this Agreement may be canceled or terminated by CITY and all money due or to become hereunder may be forfeited, for a second or any subsequent violations of the terms or conditions under this section of the Agreement.

5.09 Workmanship and Quality of Materials

5.09.01 CONTRACTOR shall guarantee the work for a period of one (1) year from the date of substantial completion. Failure of any portion of the work within one (1) year due to improper construction, materials of construction, or design may result in a refund to CITY of the purchase price of that portion which failed or may result in the forfeiture of CONTRACTOR's Performance Bond.

5.09.02 OR EQUAL: Wherever in any of the Agreement Documents an article, material or equipment is defined by describing a proprietary product, or by using the name of a manufacturer or vender, the term "Or Equal" or the term "The Equivalent" if not inserted, shall be implied, and it is done for the express purpose of establishing a basis of durability and efficiency and not for the purpose of limiting completion. Whenever material or equipment is submitted for approval as being equal to that specified, the submittal shall include sufficient information and data to demonstrate that the material or equipment conforms to the Contract requirements. The decision as to whether or not such material or equipment is equal to that specified shall be made by the ENGINEER. The approval by the ENGINEER of alternate material or equipment as being equivalent to that specified, shall not in any way relieve CONTRACTOR of responsibility for failure of the material or equipment due to faulty design, material, or workmanship, to perform the function required by the Contract Documents. Specifications as determined by other entities within the City of Bloomington such as City Utilities shall only be substituted or changed by their approval which shall be submitted in writing to the ENGINEER.

5.09.03 CITY shall be the sole judge of the sufficiency of workmanship and quality of materials. Disputes shall be resolved by the City Engineer and are not subject to arbitration.

5.10 Safety. CONTRACTOR shall be responsible for the safety of employees at all times and shall provide all equipment necessary to insure their safety. CONTRACTOR shall ensure the enforcement of all applicable safety rules, regulations,

ordinances and laws, whether federal, state or local. Contractor's Superintendent of Safety shall make daily inspections upon the arrival and leaving of the site at the close of each workday.

5.10.01 CONTRACTOR is required to comply with IOSHA regulations 29 C.F.R 1926, Subpart P, Excavations for all trenches of at least five (5) feet in depth. All cost for trench safety systems shall be the responsibility of the CONTRACTOR and included in the cost of the principal work with which the safety systems are associated. CONTRACTOR shall sign an affidavit, attached as Attachment B, affirming that CONTRACTOR shall maintain compliance with IOSHA requirements for excavations of at least five (5) in depth.

5.11 Amendments/Changes

5.11.01 Except as provided in Paragraph 5.11.02, this Agreement may be amended only by written instrument signed by both CITY and CONTRACTOR.

5.11.02 Without invalidating the Agreement and without notice to any surety, CITY may, at any time or from time to time, order, in writing, additions, deletions, or revisions in the work. Upon receipt of any such document, CONTRACTOR shall promptly proceed with the work involved, which will be performed under the applicable conditions of the Agreement Documents.

5.11.03 If CONTRACTOR believes that any direction of CITY under paragraph 5.11.02, or any other event or condition, will result in an increase in the Contract time or price, he shall file written notice with CITY no later than twenty (20) calendar days after the occurrence of the event giving rise to the claim and stating the general nature of the claim with supporting data. No claim for any adjustment of the Contract time or price will be valid if not submitted in accordance with this Paragraph.

5.11.04 CONTRACTOR shall carry on the work and adhere to the progress schedule during all disputes or disagreements with CITY. No work shall be delayed or postponed pending resolution of any dispute or disagreement except as CONTRACTOR and CITY may otherwise agree in writing.

5.12 Performance Bond and Payment Bond

5.12.01 For contracts in excess of \$100,000, CONTRACTOR shall provide CITY with both a Performance Bond and a Payment Bond in the amount of one hundred percent (100%) of the contract amount.

5.12.02 Failure by CONTRACTOR to perform the work in a timely or satisfactory fashion may result in forfeiture of CONTRACTOR'S Performance Bond.

5.12.03 Failure by CONTRACTOR to pay for labor and services performed, material furnished or services rendered may result in forfeiture of CONTRACTOR's Payment Bond.

5.12.04 If the surety on any bond furnished by CONTRACTOR becomes a party to supervision, liquidation, or rehabilitation action pursuant Indiana Code 27-9 et seq. or its right to do business in the State of Indiana is terminated, CONTRACTOR shall, within thirty (30) calendar days thereafter, substitute another bond and surety, both of which must be acceptable to CITY.

5.13 Payment of Subcontractors CONTRACTOR shall pay all subcontractors, laborers, material suppliers and those performing services to CONTRACTOR on the project under this Agreement. CITY may, as a condition precedent to any payment hereunder, require CONTRACTOR to submit satisfactory evidence of payments of any and all claims of subcontractors, laborers, material suppliers, and those furnishing services to CONTRACTOR. Upon receipt of a lawful claim, CITY shall withhold money due to CONTRACTOR in a sufficient amount to pay the subcontractors, laborers, material suppliers, and those furnishing services to CONTRACTOR.

5.13.01 The surety of the Payment Bond may not be released until one (1) year after the Board's final settlement with the CONTRACTOR.

5.14 Written Notice Written notice shall be considered as served when delivered in person or sent by mail to the individual, firm, or corporation, or to the last business address of such known to CONTRACTOR who serves the Notice. Notice shall be sent as follows:

TO CITY:

TO CONTRACTOR:

City of Bloomington Public Works Dept.	Air Technology Solutions, LLC
Attn: J. D. Boruff, Asst. Director, Facilities	Attn: Daniel Orto
P.O. Box 100	P.O. Box 267
Bloomington, Indiana 47402	Princeton, Wisconsin 54968

5.15 Severability and Waiver In the event that any clause or provision of this Agreement is held to be invalid by any court of competent jurisdiction, the invalidity of such clause or provision shall not affect any other provision of this Agreement. Failure of either party to insist on strict compliance with any provision of this Agreement shall not constitute waiver of that party's right to demand later compliance with the same or other provisions of this Agreement.

5.16 Notice to Proceed CONTRACTOR shall not begin the work pursuant to the "Scope of Work" of this Agreement until it receives an official written Notice to Proceed from the City. Contractor shall start active and continuous work on the Agreement within fifteen (15) calendar days after the date of the Notice to Proceed. In no case shall work begin prior to the date of the Notice to Proceed. If a delayed starting date is indicated in the proposal, the fifteen (15) calendar day limitation will be waived. Work day charges will then begin on a date mutually agreed upon, but not later than the delayed starting date specified. In the event that any Agreement is canceled after an award has been made but prior to the issuing of the Notice to Proceed, no reimbursement will be made for any expenses accrued relative to this contract during that period.

5.17 Steel or Foundry Products

5.17.01 To comply with Indiana Code 5-16-8, affecting all contracts for the construction, reconstruction, alteration, repair, improvement or maintenance of public works, the following provision shall be added: If steel or foundry products are to be utilized or supplied in the performance of any contract or subcontract, only domestic steel or foundry products shall be used. Should CITY feel that the cost of domestic steel or foundry products is unreasonable; CITY will notify CONTRACTOR in writing of this fact.

5.17.02 Domestic Steel products are defined as follows:

"Products rolled, formed, shaped, drawn, extruded, forged, cast, fabricated or otherwise similarly processed, or processed by a combination of two (2) or more of such operations, from steel made in the United States by open hearth, basic oxygen, electric furnace, Bessemer or other steel making process."

5.17.03 Domestic Foundry products are defined as follows:

"Products cast from ferrous and nonferrous metals by foundries in the United States."

5.17.04 The United States is defined to include all territory subject to the jurisdiction of the United States.

5.17.05 CITY may not authorize or make any payment to CONTRACTOR unless CITY is satisfied that CONTRACTOR has fully complied with this provision.

5.18 Verification of Employees' Immigration Status

Contractor is required to enroll in and verify the work eligibility status of all newly-hired employees through the E-Verify program. (This is not required if the E-Verify program no longer exists). Contractor shall sign an affidavit, attached as Attachment C, affirming that Contractor does not knowingly employ an unauthorized alien. "Unauthorized alien" is defined at 8 U.S. Code 1324a(h)(3) as a person who is not a U.S. citizen or U.S. national and is not lawfully admitted for permanent residence or authorized to work in the U.S. under 8 U.S. Code Chapter 12 or by the U.S. Attorney General.

Contractor and any of its subcontractors may not knowingly employ or contract with an unauthorized alien, or retain an employee or contract with a person that the Contractor or any of its subcontractors learns is an unauthorized alien. If the City obtains information that the Contractor or any of its subcontractors employs or retains an employee who is an unauthorized alien, the City shall notify the Contractor or its subcontractors of the Agreement violation and require that the violation be remedied within thirty (30) calendar days of the date of notice. If the Contractor or any of its subcontractors verify the work eligibility status of the employee in question through the E-Verify program, there is a rebuttable presumption that the Contractor or its subcontractor did not knowingly employ an unauthorized alien. If the Contractor or its subcontractor fails to remedy the violation within the thirty (30) calendar day period, the City shall terminate the Agreement,

unless the City determines that terminating the Agreement would be detrimental to the public interest or public property, in which case the City may allow the Agreement to remain in effect until the City procures a new contractor. If the City terminates the Agreement, the Contractor or its subcontractor is liable to the City for actual damages.

Contractor shall require any subcontractors performing work under this Agreement to certify to the Contractor that, at the time of certification, the subcontractor does not knowingly employ or contract with an unauthorized alien and the subcontractor has enrolled in and is participating in the E-Verify program. Contractor shall maintain on file all subcontractors' certifications throughout the term of this Agreement with the City.

5.19 Non-Collusion

Contractor is required to certify that it has not, nor has any other member, representative, or agent of Contractor, entered into any combination, collusion or agreement with any person relative to the price to be offered by any person nor prevented any person from making an offer nor induced anyone to refrain from making an offer and that this offer is made without reference to any other offer. Contractor shall swear under oath, via signed affidavit, attached as Attachment D and by this reference incorporated herein, that Contractor has not engaged in any collusive conduct.

IN WITNESS WHEREOF, the parties of this Agreement have hereunto set their hands.

DATE: _____

City of Bloomington
Bloomington Board of Public Works

BY:

Kyla Cox Deckard, President

Elizabeth Karon, Member

Jennifer Lloyd, Member

John Hamilton, Mayor of Bloomington

BY:

Contractor Representative

Printed Name

Title of Contractor Representative

ATTACHMENT 'A'

"SCOPE OF WORK"

This project shall include, but is not limited to construction of new Captains Quarters according to plan set provided and including:

Labor and Materials to replace filters for 32 air filtration units, once per year, for three years.

Filters to include:

- 45 @ GM Pre-Filters, Part No. AMPF-04
- 15 @ DOP Filters, Part No. AMVBD-95
- 15 @ Carbon Filter, Part No. AMCF-26
- 21 @ MICROCON Pre-Filters, Part No. MCD-PF
- 9 @ MICROCON HEPA Filters, Part No. MCD_HP
- 18 @ MICROCON Carbon Filters, Part No. MCD-CF
- 21 MICROCON UV Bulbs, Part No. MCD-UB
- 8 @ Replacement Filters, Part No. HM400
- 8 @ Replacement Pre-Filters, Part No. HM400 Prefilter
- 5 @ CO and NO2 Replacement Sensors

ATTACHMENT 'C'

"E-Verify AFFIDAVIT"

STATE OF INDIANA)
)SS:
COUNTY OF _____)

E-VERIFY AFFIDAVIT

The undersigned, being duly sworn, hereby affirms and says that:

1. The undersigned is the _____ of _____.
a. (job title) (company name)
2. The company named herein that employs the undersigned:
 - i. has contracted with or seeking to contract with the City of Bloomington to provide services; **OR**
 - ii. is a subcontractor on a contract to provide services to the City of Bloomington.
3. The undersigned hereby states that, to the best of his/her knowledge and belief, the company named herein does not knowingly employ an "unauthorized alien," as defined at 8 United States Code 1324a(h)(3).
4. The undersigned hereby states that, to the best of his/her belief, the company named herein is enrolled in and participates in the E-verify program.

Signature

Printed Name

STATE OF INDIANA)
)SS:
COUNTY OF _____)

Before me, a Notary Public in and for said County and State, personally appeared _____ and acknowledged the execution of the foregoing this _____ day of _____, 20____.

My Commission Expires: _____

Notary Public's Signature

County of Residence: _____

Printed Name of Notary Public

Commission Number

ATTACHMENT D

NON-COLLUSION AFFIDAVIT

The undersigned offeror or agent, being duly sworn on oath, says that he has not, nor has any other member, representative, or agent of the firm, company, corporation or partnership represented by him, entered into any combination, collusion or agreement with any person relative to the price to be offered by any person nor to prevent any person from making an offer nor to induce anyone to refrain from making an offer and that this offer is made without reference to any other offer.

OATH AND AFFIRMATION

I affirm under the penalties of perjury that the foregoing facts and information are true and correct to the best of my knowledge and belief.

Dated this _____ day of _____, 20____.

(Name of Organization)

By: _____

(Name and Title of Person Signing)

STATE OF INDIANA)
) SS:
COUNTY OF _____)

Subscribed and sworn to before me this _____ day of _____, 20____.

My Commission Expires: _____

Notary Public Signature

Resident of _____ County

Printed Name

Commission Number



Board of Public Works Staff Report

**Project/Event: 2023 Service Contract with VET Environmental Engineering
for Mold Remediation Services at Public Works Facilities**

Petitioner/Representative: Public Works Facilities Division

Staff Representative: J. D. Boruff, Operations and Facilities Director

Meeting Date: October 25, 2022

This is a service agreement with VET Environmental Engineering, LLC., for mold remediation services.

Staff recommends approving the service agreement with VET Environmental Engineering, LLC., not to exceed \$50,000.00.

Respectfully submitted,

A handwritten signature in black ink that reads "JD Boruff".

J. D. Boruff
Operations and Facilities Director
Public Works Department

City of Bloomington Contract and Purchase Justification Form

Vendor: VET Environmental Engineering,

Contract Amount: \$50,000.00

This form should be completed and attached to the contract documents and forwarded to the Legal Department Attorney assigned to your Department. Contracts will not be approved by the Controller if a completed form is not included with the contract documents.

PURCHASE INFORMATION

1. Check the box beside the procurement method used to initiate this procurement: (Attach a quote or bid tabulation if applicable)

<input type="checkbox"/> Request for Quote (RFQ)	<input type="checkbox"/> Request for Proposal (RFP)	<input type="checkbox"/> Sole Source	<input checked="" type="checkbox"/> Not Applicable (NA)
<input type="checkbox"/> Invitation to Bid (ITB)	<input type="checkbox"/> Request for Qualifications (RFQu)	<input type="checkbox"/> Emergency Purchase	

2. List the results of procurement process. Give further explanation where requested.

# of Submittals: 0	Yes	No
Met city requirements?	<input type="checkbox"/>	<input type="checkbox"/>
Met item or need requirements?	<input type="checkbox"/>	<input type="checkbox"/>
Was an evaluation team used?	<input type="checkbox"/>	<input type="checkbox"/>
Was scoring grid used?	<input type="checkbox"/>	<input type="checkbox"/>
Were vendor presentations requested?	<input type="checkbox"/>	<input type="checkbox"/>

Was the lowest cost selected? (If no, please state below why it was not.)	Yes	No
	<input type="checkbox"/>	<input checked="" type="checkbox"/>

VET Environmental Engineering is a contractor we have a service agreement with. This was not a procurement method.

3. State why this vendor was selected to receive the award and contract:

This is to renew our 2023 service agreement with VET Environmental Engineering.

Print/Type Name

Print/Type Title

Department

**AGREEMENT BETWEEN CITY OF BLOOMINGTON
PUBLIC WORKS DEPARTMENT AND
VET ENVIRONMENTAL ENGINEERING, LLC**

This Agreement, entered into on this 25th day of October, 2022, by and between the City of Bloomington Department of Public Works (the “Department”), and VET Environmental Engineering, LLC (“Contractor”).

Article 1. Scope of Services Contractor shall perform mold inspection and remediation, as well as facility inspections and subsequent reporting, at all facilities maintained by the Department. Contractor shall also act as a consultant for the Department to obtain various permits and approvals necessary for the construction or renovation of Department owned properties. These services will be performed at City facilities (“Services”) for a set price. These rates shall be One Hundred Thirty Five Dollars (\$135.00) per hour for a Principal Engineer, Ninety Seven Dollars (\$97.00) per hour for Senior Project Managers, and Fifty Five Dollars (\$55.00) per hour for Clerical drafting services. Contractor shall also be reimbursed by the Department for reasonable travel expenses that they might incur.

Outside services and expenses incurred by the contractor shall be billed at contractor cost plus 15%. Contractor shall diligently provide the Services under this Agreement and shall complete the Services described in this Agreement in a timely manner consistent with the Standard of Care identified in Article 2. Contractor shall complete the Services required under this Agreement on or before Friday, December 31st, 2023, unless the parties mutually agree to a later completion date. Completion shall mean completion of all work related to the Services. In the performance of Contractor’s work, Contractor agrees to maintain such coordination with the Department as may be requested and desirable, including primary coordination with J. D. Boruff, Operations and Facilities Director, Public Works Department. Contractor agrees that any information or documents, including digital GIS information, supplied by the Department pursuant to Article 3, below, shall be used by Contractor for this project only, and shall not be reused or reassigned for any other purpose without the written permission of the Department.

Article 2. Standard of Care Contractor shall be responsible for completion of the Services in a manner consistent with that degree of care and skill ordinarily exercised by members of the same profession currently practicing under similar circumstances (“Standard of Care”). The Department shall be the sole judge of the adequacy of Contractor’s work in meeting the Standard of Care; however, the Department shall not unreasonably withhold its approval as to the adequacy of Contractor’s performance. Upon notice to Contractor and by mutual agreement between the parties, Contractor will, without additional compensation, correct or replace any and all Services not meeting the Standard of Care.

Article 3. Responsibilities of the Department The Department shall provide all necessary information regarding requirements for the Services. The Department shall furnish such information as necessary for the orderly progress of the work, and Contractor shall be entitled to rely upon the accuracy and completeness of such information. The Department’s Project Manager shall act on its behalf with respect to this Agreement.

Article 4. Compensation The Department shall pay Contractor for all fees and expenses in an amount not to exceed Fifty Thousand Dollars (\$50,000.00). Contractor shall submit an invoice to the Department upon the completion of the Services described in Article 1. The invoice shall be sent to: J. D. Boruff, City of Bloomington Public Works, 401 N. Morton, Suite 120, Bloomington, Indiana 47404. Invoices may be sent via first class mail postage prepaid or via email. Payment will be remitted to Contractor within forty-five (45) days of receipt of invoice. Additional services not set forth in Article 1, or changes in the Services must be authorized in writing by the Department or its designated project coordinator prior to such work being performed, or expenses incurred. The Department shall not make payment for any unauthorized work or expenses.

Article 5. Appropriation of Funds Notwithstanding any other provision of this Agreement, if funds for the continued fulfillment of this Agreement by the Department are at any time not forthcoming or are insufficient, through failure of any entity, including the Department itself, to appropriate funds or otherwise, then the Department shall have the right to terminate this Agreement without penalty.

Article 6. Schedule Contractor shall perform the Services according to the following schedule: Services will be on as needed basis upon request of the Department. The time limits established by this schedule shall not be exceeded, except for reasonable cause as mutually agreed to by all parties.

Article 7. Termination In the event of a party's substantial failure to perform in accordance with the terms of this Agreement, the other party shall have the right to terminate the Agreement upon written notice. The nonperforming party shall have fourteen (14) calendar days from the receipt of the termination notice to cure or to submit a plan for cure acceptable to the other party. Additionally, the Department may terminate or suspend performance of this Agreement at the Department's prerogative at any time upon written notice to Contractor. Contractor shall terminate or suspend performance of the Services on a schedule acceptable to the Department and the Department shall pay the Contractor for all the Services performed up to the date that written notice is received, plus reasonable termination or suspension expenses. Upon restart, an equitable adjustment shall be made to Contractor's compensation and the schedule of services. Upon termination or suspension of this Agreement, all finished or unfinished reports, drawings, collections of data and other documents generated by Contractor in connection with this Agreement shall become the property of the Department, as set forth in Article 9 herein.

Article 8. Identity of the Contractor Contractor acknowledges that one of the primary reasons for its selection by the Department to perform the Services is the qualifications and experience of Contractor. Contractor thus agrees that the Services to be performed pursuant to this Agreement shall be performed by Contractor. Contractor shall not subcontract any part of the Services without the prior written permission of the Department. The Department reserves the right to reject any of the Contractor's personnel or proposed outside professional sub-Contractors, and the Department reserves the right to request that acceptable replacement personnel be assigned to the project.

Article 9. Ownership of Documents and Intellectual Property All documents, drawings and specifications, including digital format files, prepared by Contractor and furnished to the Department as part of the Services shall become the property of the Department. Contractor shall retain its ownership rights in its design, drawing details, specifications, databases, computer software and other proprietary property. Intellectual property developed, utilized or modified in the performance of the Services shall remain the property of Contractor.

Article 10. Independent Contractor Status During the entire term of this Agreement, Contractor shall be an independent contractor, and in no event shall any of its personnel, agents or sub-contractors be construed to be, or represent themselves to be, employees of the Department. Contractor shall be solely responsible for the payment and reporting of all employee and employer taxes, including social security, unemployment, and any other federal, state, or local taxes required to be withheld from employees or payable on behalf of employees.

Article 11. Indemnification Contractor shall defend, indemnify, and hold harmless the City of Bloomington, the Department, and the officers, agents and employees of the City and the Department from any and all claims, demands, damages, costs, expenses or other liability arising out of the Agreement or occasioned by the reckless or negligent performance of any provision thereof, including, but not limited to, any reckless or negligent act or failure to act or any misconduct on the part of the Contractor or its agents or employees, or any independent contractors directly responsible to it (collectively "Claims").

Article 12. Insurance During the performance of any and all Services under this Agreement, Contractor shall maintain the following insurance in full force and effect: a) General Liability Insurance, with a

minimum combined single limit of \$1,000,000 for each occurrence and \$2,000,000 in the aggregate; b) Automobile Liability Insurance, with a minimum combined single limit of \$1,000,000 for each person and \$1,000,000 for each accident; c) Workers' Compensation Insurance in accordance with the statutory requirements of Title 22 of the Indiana Code; and d) Professional Liability Insurance ("Errors and Omissions Insurance") with a minimum limit of \$1,000,000 annual aggregate. All insurance policies shall be issued by an insurance company authorized to issue such insurance in the State of Indiana. The City of Bloomington, the Department, and the officers, employees and agents of each shall be named as insureds under the General Liability, Automobile, and Worker's Compensation policies, and such policies shall stipulate that the insurance will operate as primary insurance and that no other insurance of the City's will be called upon to contribute to a loss hereunder. Contractor shall provide evidence of each insurance policy to the Department prior to the commencement of work under this Agreement.

Article 13. Conflict of Interest Contractor declares that it has no present interest, nor shall it acquire any interest, direct or indirect, which would conflict with the performance of Services under this Agreement. Contractor agrees that no person having any such interest shall be employed in the performance of this Agreement.

Article 14. Waiver No failure of either party to enforce a term of this Agreement against the other shall be construed as a waiver of that term, nor shall it in any way affect the party's right to enforce that term. No waiver by any party of any term of this Agreement shall be considered to be a waiver of any other term or breach thereof.

Article 15. Severability The invalidity, illegality or unenforceability of any provision of this Agreement or the occurrence of any event rendering any portion or provision of this Agreement void shall in no way affect the validity or enforceability of any other portion or provision of this Agreement. Any void provision shall be deemed severed from this Agreement, and the balance of the Agreement shall be construed and enforced as if it did not contain the particular provision to be held void. The parties further agree to amend this Agreement to replace any stricken provision with a valid provision that comes as close as possible to the intent of the stricken provision. The provisions of this Article shall not prevent this entire Agreement from being void should a provision which is of the essence of this Agreement be determined void.

Article 16. Assignment Neither the Department nor the Contractor shall assign any rights or duties under this Agreement without the prior written consent of the other party. Unless otherwise stated in the written consent to an assignment, no assignment will release or discharge the assignor from any obligation under this Agreement.

Article 17. Third Party Rights Nothing in this Agreement shall be construed to give any rights or benefits to anyone other than the parties.

Article 18. Governing Law and Venue This Agreement shall be governed by the laws of the State of Indiana. Venue of any disputes arising under this Agreement shall be in the Monroe Circuit Court, Monroe County, Indiana.

Article 19. Non-Discrimination Contractor shall comply with City of Bloomington Ordinance 2.21.020 and all other federal, state and local laws and regulations governing non-discrimination in all regards, including, but not limited to, employment.

Article 20. Compliance with Laws In performing the Services under this Agreement, Contractor shall comply with any and all applicable federal, state and local statutes, ordinances, plans and regulations, including any and all regulations for protection of the environment. Where such statutes, ordinances, plans or regulations of any public authority having any jurisdiction over the project are in conflict, Contractor shall proceed using its best judgment only after attempting to resolve any such conflict between such

governmental agencies, and shall notify the Department in a timely manner of the conflict, attempts of resolution, and planned course of action.

Article 21. E-Verify Contractor is required to enroll in and verify the work eligibility status of all newly-hired employees through the E-Verify program. (This is not required if the E-Verify program no longer exists). Contractor shall sign an affidavit, attached as Exhibit A, affirming that Contractor does not knowingly employ an unauthorized alien. Contractor shall require any subcontractors performing work under this contract to certify to the Contractor that, at the time of certification, the subcontractor does not knowingly employ or contract with an unauthorized alien and the subcontractor has enrolled in and is participating in the E-Verify program. Contractor shall maintain on file all subcontractors' certifications throughout the term of the contract with the City.

Article 22. Notices Any notice required by this Agreement shall be made in writing to the individuals/addresses specified below:

Department: City of Bloomington Public Works, Attn: J.D. Boruff, 401 N. Morton, Suite 120, Bloomington, Indiana 47404.

Contractor: VET Environment Engineering, LLC., Attn: Sara Hamidovic, 2335 West Fountain Drive, Bloomington Indiana 47404.

Nothing contained in this Article shall be construed to restrict the transmission of routine communications between representatives of the Department and Contractor.

Article 23. Integration and Modification This Agreement, including all Exhibits incorporated by reference, represents the entire and integrated agreement between the Department and the Contractor. It supersedes all prior and contemporaneous communications, representations and agreements, whether oral or written, relating to the subject matter of this Agreement. This Agreement may be modified only by a written amendment signed by both parties hereto.

Article 24. Non-Collusion Contractor is required to certify that it has not, nor has any other member, representative, or agent of Contractor, entered into any combination, collusion, or agreement with any person relative to the price to be offered by any person nor prevented any person from making an offer nor induced anyone to refrain from making an offer and that this offer is made without reference to any other offer. Contractor shall sign an affidavit, attached hereto as Exhibit B, affirming that Contractor has not engaged in any collusive conduct. Exhibit B is attached hereto and incorporated by reference as though fully set forth.

Article 25: Renewal This Agreement may be renewed for three additional one-year terms so long as none of the terms and conditions herein are modified in any way. Renewal shall only occur upon advanced written notice by the City to the Contractor that the City wishes to renew the Agreement at least thirty (30) days, but not more than sixty (60) days, prior to the end of the current term

CITY OF BLOOMINGTON

VET ENVIRONMENTAL ENGINEERING, LLC

Beth Cate, Corporation Counsel

Sara Hamidovic, President/CEO

CITY OF BLOOMINGTON PUBLIC WORKS

Adam Wason, Director

Kyla Cox Deckard, President, Board of Public Works

**EXHIBIT A
E-VERIFY AFFIDAVIT**

STATE OF INDIANA)
)SS:
COUNTY OF _____)

AFFIDAVIT

The undersigned, being duly sworn, hereby affirms and says that:

1. The undersigned is the _____ of _____.
 (job title) (company name)
2. The company named herein that employs the undersigned:
 - i. has contracted with or seeking to contract with the City of Bloomington to provide services; **OR**
 - ii. is a subcontractor on a contract to provide services to the City of Bloomington.
3. The undersigned hereby states that, to the best of his/her knowledge and belief, the company named herein does not knowingly employ an “unauthorized alien,” as defined at 8 United States Code 1324a(h)(3).
4. The undersigned hereby states that, to the best of his/her belief, the company named herein is enrolled in and participates in the E-verify program.

Signature

Printed Name

STATE OF INDIANA)
)SS:
COUNTY OF _____)

Before me, a Notary Public in and for said County and State, personally appeared _____
and acknowledged the execution of the foregoing this ____ day of _____, 2019.

Notary Public’s Signature My Commission Expires: _____

Printed Name of Notary Public County of Residence: _____

Commission Number

EXHIBIT B

STATE OF INDIANA)
) SS:
COUNTY OF _____)

NON-COLLUSION AFFIDAVIT

The undersigned offeror or agent, being duly sworn on oath, says that he has not, nor has any other member, representative, or agent of the firm, company, corporation or partnership represented by him, entered into any combination, collusion or agreement with any person relative to the price to be offered by any person nor to prevent any person from making an offer nor to induce anyone to refrain from making an offer and that this offer is made without reference to any other offer.

OATH AND AFFIRMATION

I affirm under the penalties of perjury that the foregoing facts and information are true and correct to the best of my knowledge and belief.

Dated this _____ day of _____, 2022.

VET ENVIRONMENTAL ENGINEERING, LLC

By: _____

STATE OF INDIANA)
) SS:
COUNTY OF _____)

Before me, a Notary Public in and for said County and State, personally appeared _____ and acknowledged the execution of the foregoing this _____ day of _____, 2022.

Notary Public's Signature My Commission Expires: _____

Printed Name of Notary Public County of Residence: _____

Commission Number



Board of Public Works Staff Report

**Project/Event: Service Agreement with Strauser Construction Co., Inc. for
Maintenance and Repair Services**

Petitioner/Representative: Public Works Facilities Division

Staff Representative: J. D. Boruff, Operations and Facilities Director

Meeting Date: October 25, 2022

This service agreement is for carpentry, drywall, painting, fencing, and masonry repairs and replacement at various facilities maintained by Public Works Facilities Division.

Staff recommends awarding the contract to Strauser Construction Co., Inc. not to exceed \$25,000.00.

Respectfully submitted,

A handwritten signature in black ink that reads "J. D. Boruff". The signature is written in a cursive, flowing style.

J. D. Boruff
Operations and Facilities Director
Public Works Department

City of Bloomington Contract and Purchase Justification Form

Vendor: Stauser Construction Co., Inc.

Contract Amount: \$25,000.00

This form should be completed and attached to the contract documents and forwarded to the Legal Department Attorney assigned to your Department. Contracts will not be approved by the Controller if a completed form is not included with the contract documents.

PURCHASE INFORMATION

1. Check the box beside the procurement method used to initiate this procurement: (Attach a quote or bid tabulation if applicable)

<input type="checkbox"/> Request for Quote (RFQ)	<input type="checkbox"/> Request for Proposal (RFP)	<input type="checkbox"/> Sole Source	<input checked="" type="checkbox"/> Not Applicable (NA)
<input type="checkbox"/> Invitation to Bid (ITB)	<input type="checkbox"/> Request for Qualifications (RFQu)	<input type="checkbox"/> Emergency Purchase	

2. List the results of procurement process. Give further explanation where requested.

of Submittals: 1

	Yes	No
Met city requirements?	<input checked="" type="checkbox"/>	<input type="checkbox"/>
Met item or need requirements?	<input checked="" type="checkbox"/>	<input type="checkbox"/>
Was an evaluation team used?	<input type="checkbox"/>	<input checked="" type="checkbox"/>
Was scoring grid used?	<input type="checkbox"/>	<input checked="" type="checkbox"/>
Were vendor presentations requested?	<input type="checkbox"/>	<input checked="" type="checkbox"/>

Yes No

Was the lowest cost selected? (If no, please state below why it was not.) Yes No

This is a service agreement. Contractor submitted rates of service and those are stated in the agreement.

3. State why this vendor was selected to receive the award and contract:

Strauser Construction is a reliable contractor we have had work on several projects.

J. D. Boruff

Facilities Director

Public Works

Print/Type Name

Print/Type Title

Department

**AGREEMENT BETWEEN CITY OF BLOOMINGTON
PUBLIC WORKS DEPARTMENT AND
STRAUSER CONSTRUCTION CO., INC.**

This Agreement, entered into on this 25th day of October, 2022, by and between the City of Bloomington Department of Public Works (the “Department”), and Strauser Construction Co., Inc. (“Contractor”).

Article 1. Scope of Services Contractor shall perform repair and maintenance services of the following types: carpentry, drywall, painting, wood and chain link fencing, and masonry. These services will be performed at City facilities (“Services”) for a set price. These rates for a Carpenter shall be Eighty Three Dollars and Fifty Cents (\$83.50) per hour Monday through Friday, 7:00 am to 5:00 pm, Ninety Nine Dollars and Fifty Cents (\$99.75) per hour Monday through Friday 5:00 pm to 7:00 am and on Saturday, and One Hundred Twenty Dollars and Seventy Five Cents (\$120.75) an hour on Sunday. A Laborer shall be billed at the rate of Sixty Four Dollars and Seventy Five Cents (\$64.75) per hour Monday through Friday, 7:00 am to 5:00 pm, Seventy Seven Dollars and Twenty Five Cents (\$77.25) per hour Monday through Friday 5:00 pm to 7:00 am and Saturday, and Ninety One Dollars and Twenty Five Cents (\$91.25) an hour on Sunday. Equipment shall be billed at cost plus fifteen percent (15%). Material shall be billed at cost plus fifteen percent (15%). Contractor shall diligently provide the Services under this Agreement and shall complete the Services described in this Agreement in a timely manner consistent with the Standard of Care identified in Article 2. Contractor shall complete the Services required under this Agreement on or before Tuesday, December 31st, 2023, unless the parties mutually agree to a later completion date. Completion shall mean completion of all work related to the Services. In the performance of Contractor’s work, Contractor agrees to maintain such coordination with the Department as may be requested and desirable, including primary coordination with J. D. Boruff, Operations and Facilities Director, Public Works Department. Contractor agrees that any information or documents, including digital GIS information, supplied by the Department pursuant to Article 3, below, shall be used by Contractor for this project only, and shall not be reused or reassigned for any other purpose without the written permission of the Department.

Article 2. Standard of Care Contractor shall be responsible for completion of the Services in a manner consistent with that degree of care and skill ordinarily exercised by members of the same profession currently practicing under similar circumstances (“Standard of Care”). The Department shall be the sole judge of the adequacy of Contractor’s work in meeting the Standard of Care; however, the Department shall not unreasonably withhold its approval as to the adequacy of Contractor’s performance. Upon notice to Contractor and by mutual agreement between the parties, Contractor will, without additional compensation, correct or replace any and all Services not meeting the Standard of Care.

Article 3. Responsibilities of the Department The Department shall provide all necessary information regarding requirements for the Services. The Department shall furnish such information as necessary for the orderly progress of the work, and Contractor shall be entitled to rely upon the accuracy and completeness of such information. The Department’s Project Manager shall act on its behalf with respect to this Agreement.

Article 4. Compensation The Department shall pay Contractor for all fees and expenses in an amount not to exceed Twenty-Five Thousand Dollars (\$25,000.00). Contractor shall submit an invoice to the Department upon the completion of the Services described in Article 1. The invoice shall be sent to: J. D. Boruff, City of Bloomington Public Works, 401 N. Morton, Suite 120, Bloomington, Indiana 47404. Invoices may be sent via first class mail postage prepaid or via email. Payment will be remitted to Contractor within forty-five (45) days of receipt of invoice. Additional services not set forth in Article 1, or changes in the Services must be authorized in writing by the Department or its designated project coordinator prior to such work being performed, or expenses incurred. The Department shall not make payment for any unauthorized work or expenses.

Article 5. Appropriation of Funds Notwithstanding any other provision of this Agreement, if funds for the continued fulfillment of this Agreement by the Department are at any time not forthcoming or are insufficient, through failure of any entity, including the Department itself, to appropriate funds or otherwise, then the Department shall have the right to terminate this Agreement without penalty.

Article 6. Schedule Contractor shall perform the Services according to the following schedule: Services will be on as needed basis upon request of the Department. The time limits established by this schedule shall not be exceeded, except for reasonable cause as mutually agreed to by all parties.

Article 7. Termination In the event of a party's substantial failure to perform in accordance with the terms of this Agreement, the other party shall have the right to terminate the Agreement upon written notice. The nonperforming party shall have fourteen (14) calendar days from the receipt of the termination notice to cure or to submit a plan for cure acceptable to the other party. Additionally, the Department may terminate or suspend performance of this Agreement at the Department's prerogative at any time upon written notice to Contractor. Contractor shall terminate or suspend performance of the Services on a schedule acceptable to the Department and the Department shall pay the Contractor for all the Services performed up to the date that written notice is received, plus reasonable termination or suspension expenses. Upon restart, an equitable adjustment shall be made to Contractor's compensation and the schedule of services. Upon termination or suspension of this Agreement, all finished or unfinished reports, drawings, collections of data and other documents generated by Contractor in connection with this Agreement shall become the property of the Department, as set forth in Article 9 herein.

Article 8. Identity of the Contractor Contractor acknowledges that one of the primary reasons for its selection by the Department to perform the Services is the qualifications and experience of Contractor. Contractor thus agrees that the Services to be performed pursuant to this Agreement shall be performed by Contractor. Contractor shall not subcontract any part of the Services without the prior written permission of the Department. The Department reserves the right to reject any of the Contractor's personnel or proposed outside professional sub-Contractors, and the Department reserves the right to request that acceptable replacement personnel be assigned to the project.

Article 9. Ownership of Documents and Intellectual Property All documents, drawings and specifications, including digital format files, prepared by Contractor and furnished to the Department as part of the Services shall become the property of the Department. Contractor shall retain its ownership rights in its design, drawing details, specifications, databases, computer software and other proprietary property. Intellectual property developed, utilized or modified in the performance of the Services shall remain the property of Contractor.

Article 10. Independent Contractor Status During the entire term of this Agreement, Contractor shall be an independent contractor, and in no event shall any of its personnel, agents or sub-contractors be construed to be, or represent themselves to be, employees of the Department. Contractor shall be solely responsible for the payment and reporting of all employee and employer taxes, including social security, unemployment, and any other federal, state, or local taxes required to be withheld from employees or payable on behalf of employees.

Article 11. Indemnification Contractor shall defend, indemnify, and hold harmless the City of Bloomington, the Department, and the officers, agents and employees of the City and the Department from any and all claims, demands, damages, costs, expenses or other liability arising out of the Agreement or occasioned by the reckless or negligent performance of any provision thereof, including, but not limited to, any reckless or negligent act or failure to act or any misconduct on the part of the Contractor or its agents or employees, or any independent contractors directly responsible to it (collectively "Claims").

Article 12. Insurance During the performance of any and all Services under this Agreement, Contractor shall maintain the following insurance in full force and effect: a) General Liability Insurance, with a

minimum combined single limit of \$1,000,000 for each occurrence and \$2,000,000 in the aggregate; b) Automobile Liability Insurance, with a minimum combined single limit of \$1,000,000 for each person and \$1,000,000 for each accident; c) Workers' Compensation Insurance in accordance with the statutory requirements of Title 22 of the Indiana Code; and d) Professional Liability Insurance ("Errors and Omissions Insurance") with a minimum limit of \$1,000,000 annual aggregate. All insurance policies shall be issued by an insurance company authorized to issue such insurance in the State of Indiana. The City of Bloomington, the Department, and the officers, employees and agents of each shall be named as insureds under the General Liability, Automobile, and Worker's Compensation policies, and such policies shall stipulate that the insurance will operate as primary insurance and that no other insurance of the City's will be called upon to contribute to a loss hereunder. Contractor shall provide evidence of each insurance policy to the Department prior to the commencement of work under this Agreement.

Article 13. Conflict of Interest Contractor declares that it has no present interest, nor shall it acquire any interest, direct or indirect, which would conflict with the performance of Services under this Agreement. Contractor agrees that no person having any such interest shall be employed in the performance of this Agreement.

Article 14. Waiver No failure of either party to enforce a term of this Agreement against the other shall be construed as a waiver of that term, nor shall it in any way affect the party's right to enforce that term. No waiver by any party of any term of this Agreement shall be considered to be a waiver of any other term or breach thereof.

Article 15. Severability The invalidity, illegality or unenforceability of any provision of this Agreement or the occurrence of any event rendering any portion or provision of this Agreement void shall in no way affect the validity or enforceability of any other portion or provision of this Agreement. Any void provision shall be deemed severed from this Agreement, and the balance of the Agreement shall be construed and enforced as if it did not contain the particular provision to be held void. The parties further agree to amend this Agreement to replace any stricken provision with a valid provision that comes as close as possible to the intent of the stricken provision. The provisions of this Article shall not prevent this entire Agreement from being void should a provision which is of the essence of this Agreement be determined void.

Article 16. Assignment Neither the Department nor the Contractor shall assign any rights or duties under this Agreement without the prior written consent of the other party. Unless otherwise stated in the written consent to an assignment, no assignment will release or discharge the assignor from any obligation under this Agreement.

Article 17. Third Party Rights Nothing in this Agreement shall be construed to give any rights or benefits to anyone other than the parties.

Article 18. Governing Law and Venue This Agreement shall be governed by the laws of the State of Indiana. Venue of any disputes arising under this Agreement shall be in the Monroe Circuit Court, Monroe County, Indiana.

Article 19. Non-Discrimination Contractor shall comply with City of Bloomington Ordinance 2.21.020 and all other federal, state and local laws and regulations governing non-discrimination in all regards, including, but not limited to, employment.

Article 20. Compliance with Laws In performing the Services under this Agreement, Contractor shall comply with any and all applicable federal, state and local statutes, ordinances, plans and regulations, including any and all regulations for protection of the environment. Where such statutes, ordinances, plans or regulations of any public authority having any jurisdiction over the project are in conflict, Contractor shall proceed using its best judgment only after attempting to resolve any such conflict between such governmental agencies, and shall notify the Department in a timely manner of the conflict, attempts of resolution, and planned course of action.

Article 21. E-Verify Contractor is required to enroll in and verify the work eligibility status of all newly-hired employees through the E-Verify program. (This is not required if the E-Verify program no longer exists). Contractor shall sign an affidavit, attached as Exhibit A, affirming that Contractor does not knowingly employ an unauthorized alien. Contractor shall require any subcontractors performing work under this contract to certify to the Contractor that, at the time of certification, the subcontractor does not knowingly employ or contract with an unauthorized alien and the subcontractor has enrolled in and is participating in the E-Verify program. Contractor shall maintain on file all subcontractors' certifications throughout the term of the contract with the City.

Article 22. Notices Any notice required by this Agreement shall be made in writing to the individuals/addresses specified below:

Department: City of Bloomington Public Works, Attn: J.D. Boruff, 401 N. Morton, Suite 120, Bloomington, Indiana 47404.

Contractor: Bounds Flooring, Inc., 5005 North State Road 37 Business., Attn: Matt McIntosh, Bloomington Indiana 47404.

Nothing contained in this Article shall be construed to restrict the transmission of routine communications between representatives of the Department and Contractor.

Article 23. Integration and Modification This Agreement, including all Exhibits incorporated by reference, represents the entire and integrated agreement between the Department and the Contractor. It supersedes all prior and contemporaneous communications, representations and agreements, whether oral or written, relating to the subject matter of this Agreement. This Agreement may be modified only by a written amendment signed by both parties hereto.

Article 24. Non-Collusion Contractor is required to certify that it has not, nor has any other member, representative, or agent of Contractor, entered into any combination, collusion, or agreement with any person relative to the price to be offered by any person nor prevented any person from making an offer nor induced anyone to refrain from making an offer and that this offer is made without reference to any other offer. Contractor shall sign an affidavit, attached hereto as Exhibit B, affirming that Contractor has not engaged in any collusive conduct. Exhibit B is attached hereto and incorporated by reference as though fully set forth.

Article 25: Renewal This Agreement may be renewed for three additional one-year terms so long as none of the terms and conditions herein are modified in any way. Renewal shall only occur upon advanced written notice by the City to the Contractor that the City wishes to renew the Agreement at least thirty (30) days, but not more than sixty (60) days, prior to the end of the current term

CITY OF BLOOMINGTON

Strauser Construction Co., Inc.

Beth Cate, Corporation Counsel

Lennie Strauser, President

CITY OF BLOOMINGTON PUBLIC WORKS

Adam Wason, Director

Kyla Cox Deckard, President, Board of Public Works

EXHIBIT A
E-VERIFY AFFIDAVIT

STATE OF INDIANA)
)SS:
COUNTY OF _____)

AFFIDAVIT

The undersigned, being duly sworn, hereby affirms and says that:

1. The undersigned is the _____ of _____.
(job title) (company name)
2. The company named herein that employs the undersigned:
 - i. has contracted with or seeking to contract with the City of Bloomington to provide services; **OR**
 - ii. is a subcontractor on a contract to provide services to the City of Bloomington.
3. The undersigned hereby states that, to the best of his/her knowledge and belief, the company named herein does not knowingly employ an "unauthorized alien," as defined at 8 United States Code 1324a(h)(3).
4. The undersigned hereby states that, to the best of his/her belief, the company named herein is enrolled in and participates in the E-verify program.

Signature

Printed Name

STATE OF INDIANA)
)SS:
COUNTY OF _____)

Before me, a Notary Public in and for said County and State, personally appeared _____
and acknowledged the execution of the foregoing this _____ day of _____, 2022.

Notary Public's Signature My Commission Expires: _____

Printed Name of Notary Public County of Residence: _____



Board of Public Works Staff Report

Project/Event: Renewal #2 ReCollect Digital Recycling Education Software

Petitioner/Representative: Public Works Department

Staff Representative: Michael Large, Operations Manager

Meeting Date: October 25, 2022

The ReCollect software system provides digital recycling education and outreach to the public through enhanced website tools and features for the municipal sanitation industry. The ReCollect software continues to provide the public with convenient recycling educational information and content, as well as making several regular sanitation services more easily accessible.

Staff has been extremely satisfied with the capabilities of the system that consists of the three modules listed below:

- **Collection Calendar:** Residents can access the calendar from a website tool and easily find their collection schedule. They can also subscribe to receive collection day reminders and notifications via e-mail, text message, or an automated phone call. With over 6,300 first time users in the first 18 months of service this module was vital in sending notice to the public during weather related service delays
- **Special Collection:** A tool that allows residents to self-schedule on-line for additional services (i.e. bulky items, appliances, or extra weekly pick-ups). Has reduced phone calls and efficiency with large item pickup. This feature is key in scheduling the removal of large items during student turnover in the fall and spring.
- **Waste Wizard:** Provides real-time, searchable and specific instructions on how people should dispose of any material (essentially, what's trash and what's recyclable). With more than 2,550 first time users and over 9,000 individual searches, this system continues to be a vital educational tool for the ever changing recycling market situation.



Scan QR to access the site with your smartphone.

City of Bloomington Contract and Purchase Justification Form

Vendor: ReCollect Systems INC.

Contract Amount: \$12,741.12

This form should be completed and attached to the contract documents and forwarded to the Legal Department Attorney assigned to your Department. Contracts will not be approved by the Controller if a completed form is not included with the contract documents.

PURCHASE INFORMATION

1. Check the box beside the procurement method used to initiate this procurement: (Attach a quote or bid tabulation if applicable)

<input type="checkbox"/> Request for Quote (RFQ)	<input type="checkbox"/> Request for Proposal (RFP)	<input type="checkbox"/> Sole Source	<input checked="" type="checkbox"/> Not Applicable (NA)
<input type="checkbox"/> Invitation to Bid (ITB)	<input type="checkbox"/> Request for Qualifications (RFQu)	<input type="checkbox"/> Emergency Purchase	

2. List the results of procurement process. Give further explanation where requested. Yes No

# of Submittals:	Yes	No	Was the lowest cost selected? (If no, please state below why it was not.)	<input type="checkbox"/>	<input type="checkbox"/>
Met city requirements?	<input type="checkbox"/>	<input type="checkbox"/>	This renewal #1 of the Service Contract.	<input type="checkbox"/>	<input type="checkbox"/>
Met item or need requirements?	<input type="checkbox"/>	<input type="checkbox"/>			
Was an evaluation team used?	<input type="checkbox"/>	<input type="checkbox"/>			
Was scoring grid used?	<input type="checkbox"/>	<input type="checkbox"/>			
Were vendor presentations requested?	<input type="checkbox"/>	<input type="checkbox"/>			

3. State why this vendor was selected to receive the award and contract:

This vendor provides a specific service through software and data collections that has allowed us to specifically target areas of contamination with the recycling collection stream. Through this identification we are able to provide education and explanation for our services to the general public. Since we have purchased this software we have brought more than 2,000 individual residents on as subscribers for the reminder and special collection services provided through this vendor's proprietary software.

Renewals occur automatically unless a party informs the other in writing at least 30 days before end of the term. Fees for initial contract totaled \$11,508.15. Fees for the first renewal totaled \$11,699.00. Fees for the second renewal term will be \$12,741.12

Michael Large

Print/Type Name

Operations Manager

Print/Type Title

Public Works

Department

**RENEWAL # 2 BETWEEN THE
CITY OF BLOOMINGTON
And
RECOLLECT SYSTEMS INC.**

The initial Term of this Agreement began on December 1, 2021, and shall end on November 30, 2022. This Renewal #2 extends this Agreement as follows:

1. **Section 4.2 Term.** This Subscription Services Agreement shall automatically renew for additional one (1) year terms, unless a party provides written notice of intent to terminate to the other party at least 30 days before the Termination Date of the current Term. The renewal term shall begin on December 1, 2022 and shall end on November 30, 2023.

2. **Section 5.3 Inflation.** The fees will increase on each one year anniversary of the Effective Date by the rate of CPI inflation as defined by the US Bureau of Labor Statistics. Fees during the Initial Term of this Agreement totaled \$11,508.15. Fees for the first Renewal Term shall be \$11,699.00. Fees for the second Renewal Term shall be \$12,741.12

3. **Section 10. Indemnification** shall be amended for both ReCollect and the City of Bloomington to delete the word “defend” from the first line of both **10.1 ReCollect Indemnification** and **10.2 Customer Indemnification**, such that each party is still required to “indemnify and hold harmless” the other.

4. In all other respects, the Agreement shall remain in effect as originally written.

IN WITNESS WHEREOF, the parties have caused this Addendum to be executed the day and year last written below:

CITY OF BLOOMINGTON

RECOLLECT SYSTEMS INC.

By: _____
Kyla Cox Deckard, President
Board of Public Works

By: _____

Name and Title

Date: _____

Date: _____

By: _____
Adam Wason, Director
Public Works Department

Date: _____

By: _____
Beth Cate, Corporation Counsel

Date: _____



Board of Public Works Staff Report

Project/Event: Outdoor Lighting Service Agreements with Duke Energy

Petitioner/Representative: Department of Public Works

Staff Representative: Christina Smith

Meeting Date: October 25, 2022

Department of Public Works (DPW) has requested and received an outdoor lighting service agreement for two (2) additional street lights to enhance the illumination levels within the City's section of the Showers Governmental Complex at the following locations:

Summary of Contract: Phase 3 of the Showers Complex LED Lighting Conversion Project

Locations: Southern section of the City employee parking lot and near the mail boxes

Fixtures: Two (2) LED fixtures; one (1) 150 Watt and one (1) 70 Watt Sanibel fixtures with a green finish

Color Temperature: 4,000 Kelvin

Poles: Two (2) Aluminum poles with a green finish

Funding Source: Local Roads and Streets Fund

One Time Equipment Charge: \$11,982.50

Estimated Monthly Charge: \$23.99

The City has elected to pay the total one time charge for equipment costs in the amount of \$11,982.50, and \$23.99 energy usage, and maintenance monthly costs. All of the associated costs with these lights will be paid out of the Local Road & Street Fund within the Street Operations Division's budget.

City of Bloomington Contract and Purchase Justification Form

Vendor: Duke Energy

Contract Amount: \$11,982.50

This form should be completed and attached to the contract documents and forwarded to the Legal Department Attorney assigned to your Department. Contracts will not be approved by the Controller if a completed form is not included with the contract documents.

PURCHASE INFORMATION

1. Check the box beside the procurement method used to initiate this procurement: (Attach a quote or bid tabulation if applicable)

<input type="checkbox"/> Request for Quote (RFQ)	<input type="checkbox"/> Request for Proposal (RFP)	<input checked="" type="checkbox"/> Sole Source	<input type="checkbox"/> Not Applicable (NA)
<input type="checkbox"/> Invitation to Bid (ITB)	<input type="checkbox"/> Request for Qualifications (RFQu)	<input type="checkbox"/> Emergency Purchase	

2. List the results of procurement process. Give further explanation where requested. Yes No

# of Submittals:	Yes	No	Was the lowest cost selected? (If no, please state below why it was not.)	Yes	No
Met city requirements?	<input checked="" type="checkbox"/>	<input type="checkbox"/>		<input type="checkbox"/>	<input type="checkbox"/>
Met item or need requirements?	<input checked="" type="checkbox"/>	<input type="checkbox"/>			
Was an evaluation team used?	<input type="checkbox"/>	<input checked="" type="checkbox"/>			
Was scoring grid used?	<input type="checkbox"/>	<input checked="" type="checkbox"/>			
Were vendor presentations requested?	<input type="checkbox"/>	<input checked="" type="checkbox"/>			

3. State why this vendor was selected to receive the award and contract:

Duke Energy is a sole source provider for street light installation within the public right of way. The City leases street lights from Duke Energy and pays for the installation costs, energy, and maintenance costs with Duke providing the maintenance services. The City does not have the labor force or equipment necessary to provide maintenance services for over 3,000 street lights within the public right of way.

Christina Smith

Project Coordinator

Department of Public Works

Print/Type Name

Print/Type Title

Department



IN01 LIGHTING SERVICE AGREEMENT

Account Information:
CITY OF BLOOMINGTON
PO BOX 100
BLOOMINGTON IN

Project Information:

Indiana

Account Number:

Work Order Number:
46699582

Customer Contact Information:
CITY OF BLOOMINGTON
SMITHC@BLOOMINGTON.IN.GOV

Duke Energy Representative Contact Info:
Craig Barker

..

This Lighting Service Agreement is hereby entered into this 7th day of October, 2022, between Duke Energy (hereinafter called the "Company") and CITY OF BLOOMINGTON (hereinafter referred to as the "Customer") for lighting service at the above location(s). The Customer agrees to receive and pay for lighting service from the Company in accordance with the rates, terms and provisions of the Company's Rate Schedule LED and Service Regulations, or its successor, as the same is on file with the Indiana Public Service Commission (INDIANA UTILITY REGULATORY COMMISSION) and as may be amended and subsequently filed with the INDIANA UTILITY REGULATORY COMMISSION.

To the extent there is any conflict between this Agreement and the Lighting Service Rate Schedule, the Lighting Service Rate Schedule shall control. In the event of termination by the Customer during the initial term of this agreement under this rate schedule or upon early termination of service under this schedule, the customer agrees to pay remaining terms of this agreement as delegated by the INDIANA UTILITY REGULATORY COMMISSION.

The date of *initiation* of service shall be defined as the date the first light(s) is energized or billing is transferred and shall continue hereafter until terminated *by either party upon written notice 22 days prior to termination*. It is further agreed that Duke Energy reserves the right to discontinue service and remove any Duke Energy-owned facilities from the Customers premise if the Customer violates any of the terms of the Service Regulations, Rate Schedule or this Agreement.

Customer Signature _____

Date Signed _____

Duke Energy Representative Craig Barker

Date Signed 10/7/2022



Summary of Estimated Charges				
Minimum Service Term	Initial Monthly Cost	Total One Time Charges	Total Cost for Initial term	Ongoing Monthly Charge post Term
0 Years () Months	23.99	11982.50	11982.50	23.99

Monthly Base Charges							
Service Required	Quantity	Product Description Fixtures and Poles	Equipment Rental**	Maintenance	Energy	Unit Total	Sub-Total
I	001	LFIX-SAN-LED-150-GRN-III-M	5991.25	9.31	3.66	6004.22	6004.22
I	001	LFIX-SAN-LED-70-GRN-III-M	5991.25	9.31	1.71	6002.27	6002.27
		Rental, Maintenance, F&E Totals:	\$11,982.50	\$18.62	\$5.37		
Estimated Change to Base Monthly Charge Total							\$12,006.49

THIS IS NOT A BILL. PLEASE DO NOT SEND A PAYMENT IN RESPONSE TO THIS COMMUNICATION.

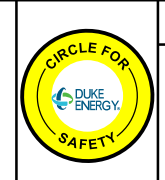

REMEMBER: Work zone area conditions may have changed for this job! Everyone is responsible for verifying the above safety information is correct prior to any work being performed each day.

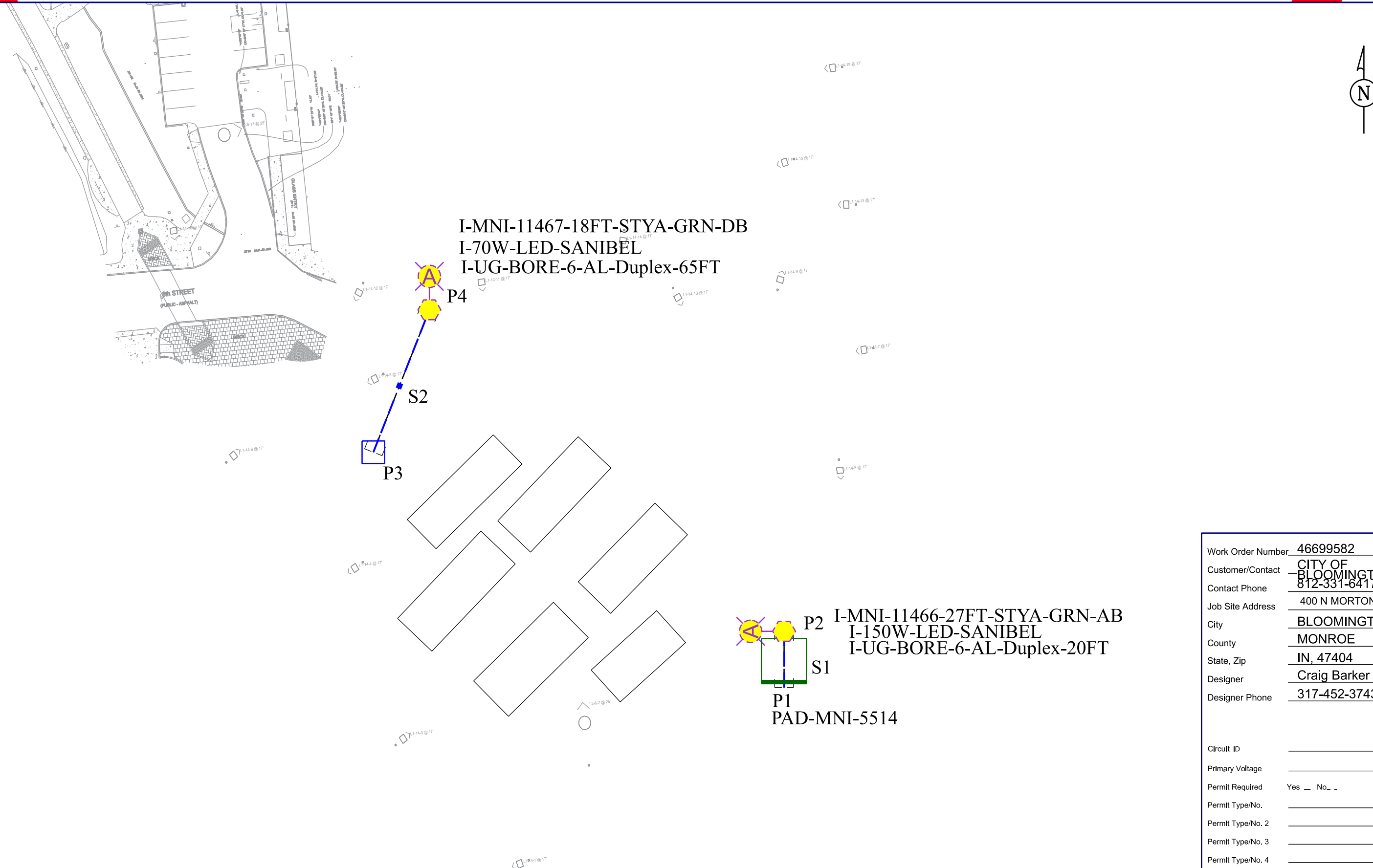

Work Order Number	46699582
Customer/Contact	CITY OF BLOOMINGTON
Contact Phone	812-331-6417
Job Site Address	400 N MORTON ST
City	BLOOMINGTON
County	MONROE
State, Zip	IN, 47404
Designer	Craig Barker
Designer Phone	317-452-3743
Circuit ID	
Primary Voltage	
Permit Required	Yes _ No _
Permit Type/No.	
Permit Type/No. 2	
Permit Type/No. 3	
Permit Type/No. 4	



Board of Public Works Staff Report

Project/Event: Outdoor Lighting Service Agreements with Duke Energy

Petitioner/Representative: Department of Public Works

Staff Representative: Christina Smith

Meeting Date: October 25, 2022

Department of Public Works has requested and received an outdoor lighting service agreement to replace the existing HPS cobrahead street light with a new pedestrian scale LED Traditional street light. The HPS cobrahead fixture is creating a light trespass issue for a resident on the northwest corner of W Allen St and S Madison St.

Summary of Contract: Intersection of W Allen St and S Madison St

Locations: Intersection of Intersection of W Allen St and S Madison St

Fixture: One (1) 50 Watt Traditional fixture with a black finish

Color Temperature: 3,000 Kelvin

Pole: One (1) Aluminum pole with a black finish

Funding Source: Local Roads and Streets Fund

One Time Charge: \$9,132.83

Estimated Monthly Charge: \$11.53

The City has elected to pay the total one time charge for equipment costs in the amount of \$9,132.83 and \$11.53 energy usage, and maintenance monthly costs. All of the associated costs with these lights will be paid out of the Local Road & Street Fund within the Street Operations Division's budget.

City of Bloomington Contract and Purchase Justification Form

Vendor: Duke Energy

Contract Amount: \$9,132.83

This form should be completed and attached to the contract documents and forwarded to the Legal Department Attorney assigned to your Department. Contracts will not be approved by the Controller if a completed form is not included with the contract documents.

PURCHASE INFORMATION

1. Check the box beside the procurement method used to initiate this procurement: (Attach a quote or bid tabulation if applicable)

<input type="checkbox"/> Request for Quote (RFQ)	<input type="checkbox"/> Request for Proposal (RFP)	<input checked="" type="checkbox"/> Sole Source	<input type="checkbox"/> Not Applicable (NA)
<input type="checkbox"/> Invitation to Bid (ITB)	<input type="checkbox"/> Request for Qualifications (RFQu)	<input type="checkbox"/> Emergency Purchase	

2. List the results of procurement process. Give further explanation where requested.

	Yes	No		Yes	No
# of Submittals:			Was the lowest cost selected? (If no, please state below why it was not.)	<input type="checkbox"/>	<input type="checkbox"/>
Met city requirements?	<input checked="" type="checkbox"/>	<input type="checkbox"/>			
Met item or need requirements?	<input checked="" type="checkbox"/>	<input type="checkbox"/>			
Was an evaluation team used?	<input type="checkbox"/>	<input checked="" type="checkbox"/>			
Was scoring grid used?	<input type="checkbox"/>	<input checked="" type="checkbox"/>			
Were vendor presentations requested?	<input type="checkbox"/>	<input checked="" type="checkbox"/>			

3. State why this vendor was selected to receive the award and contract:

Duke Energy is a sole source provider for street light installation within the public right of way. The City leases street lights from Duke Energy and pays for the installation costs, energy, and maintenance costs with Duke providing the maintenance services. The City does not have the labor force or equipment necessary to provide maintenance services for over 3,000 street lights within the public right of way.

 Christina Smith

Print/Type Name

 Project Coordinator

Print/Type Title

 Department of Public Works

Department



Image capture: May 2019 © 2022 Google

Bloomington, Indiana



Google

Street View - May 2019



Roads

roadclas

-  Road
-  Highway
-  Parcels

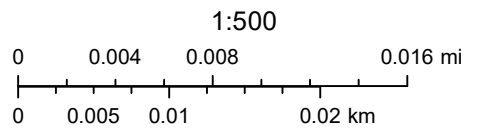



IN01 LIGHTING SERVICE AGREEMENT

Account Information:
CITY OF BLOOMINGTON
PO BOX 100
BLOOMINGTON IN

Project Information:

Indiana

Account Number:

Work Order Number:
46591095

Customer Contact Information:
CITY OF BLOOMINGTON
N/A

Duke Energy Representative Contact Info:

..

This Lighting Service Agreement is hereby entered into this 3rd day of October, 2022, between Duke Energy (hereinafter called the "Company") and CITY OF BLOOMINGTON (hereinafter referred to as the "Customer") for lighting service at the above location(s). The Customer agrees to receive and pay for lighting service from the Company in accordance with the rates, terms and provisions of the Company's Rate Schedule LED and Service Regulations, or its successor, as the same is on file with the Indiana Public Service Commission (INDIANA UTILITY REGULATORY COMMISSION) and as may be amended and subsequently filed with the INDIANA UTILITY REGULATORY COMMISSION.

To the extent there is any conflict between this Agreement and the Lighting Service Rate Schedule, the Lighting Service Rate Schedule shall control. In the event of termination by the Customer during the initial term of this agreement under this rate schedule or upon early termination of service under this schedule, the customer agrees to pay remaining terms of this agreement as delegated by the INDIANA UTILITY REGULATORY COMMISSION.

The date of *initiation* of service shall be defined as the date the first light(s) is energized or billing is transferred and shall continue hereafter until terminated *by either party upon written notice 22 days prior to termination*. It is further agreed that Duke Energy reserves the right to discontinue service and remove any Duke Energy-owned facilities from the Customers premise if the Customer violates any of the terms of the Service Regulations, Rate Schedule or this Agreement.

Customer Signature _____

Date Signed _____

Duke Energy Representative Craig Barker

Date Signed 10/3/2022

THIS IS NOT A BILL. PLEASE DO NOT SEND A PAYMENT IN RESPONSE TO THIS COMMUNICATION.



Summary of Estimated Charges				
Minimum Service Term	Initial Monthly Cost	Total One Time Charges	Total Cost for Initial term	Ongoing Monthly Charge post Term
0 Years () Months	11.53	9132.83	9132.83	11.53

Monthly Base Charges							
Service Required	Quantity	Product Description Fixtures and Poles	Equipment Rental**	Maintenance	Energy	Unit Total	Sub-Total
I	001	LFIX-TRAD-LED-50- BLK-V-3000K-M	9132.83	10.31	1.22	9144.36	9144.36
		Rental, Maintenance, F&E Totals:	\$9,132.83	\$10.31	\$1.22		
Estimated Change to Base Monthly Charge Total							\$9,144.36

THIS IS NOT A BILL. PLEASE DO NOT SEND A PAYMENT IN RESPONSE TO THIS COMMUNICATION.

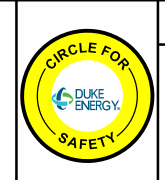

REMEMBER: Work zone area conditions may have changed for this job! Everyone is responsible for verifying the above safety information is correct prior to any work being performed each day.

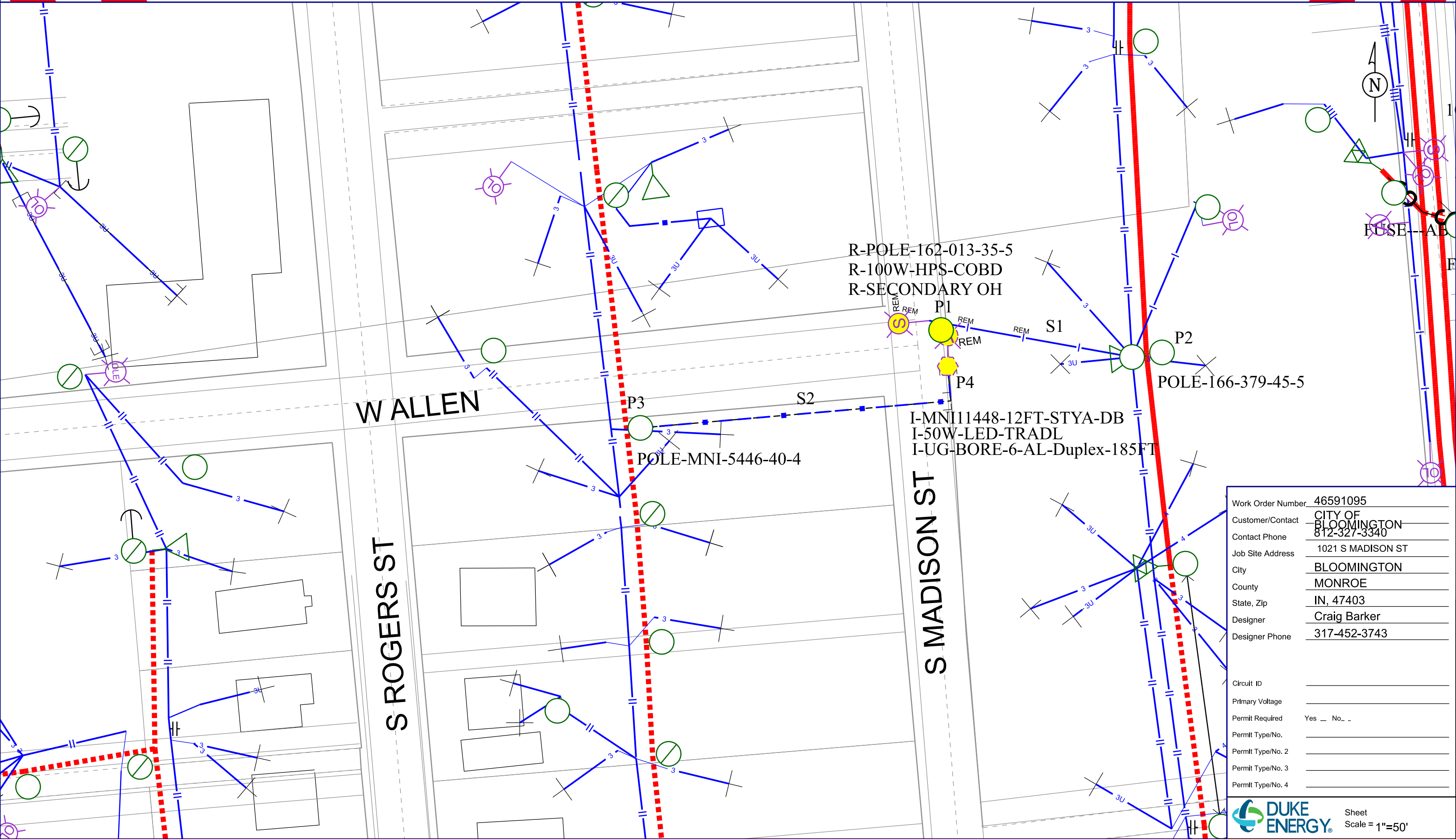

Work Order Number	46591095
Customer/Contact	CITY OF BLOOMINGTON
Contact Phone	812-327-3340
Job Site Address	1021 S MADISON ST
City	BLOOMINGTON
County	MONROE
State, Zip	IN, 47403
Designer	Craig Barker
Designer Phone	317-452-3743
Circuit ID	
Primary Voltage	
Permit Required	Yes _ No _
Permit Type/No.	
Permit Type/No. 2	
Permit Type/No. 3	
Permit Type/No. 4	

REGISTER OF PAYROLL CLAIMS
Board: Board of Public Works Claim Register

Date:	Type of Claim	FUND	Description	Bank Transfer	Amount
10/21/2022	Payroll				490,181.55
					<u>490,181.55</u>

ALLOWANCE OF CLAIMS

We have examined the claims listed on the foregoing register of claims, consisting of 1
claim, and except for the claims not allowed as shown on the register, such claims are hereby allowed in the
total amount of \$ 490,181.55

Dated this 25th day of October year of 2022.

Kyla Cox Deckard, President Jennifer Lloyd, Vice President Elizabeth Karon, Secretary

I hereby certify that each of the above listed voucher(s) or bill(s) is (are) true and correct and I have audited same in accordance with IC 5-11-10-1.6.

Fiscal Officer _____



Board of Public Works Staff Report

Project/Event: Atlantic Engineering Group (AEG)
Staff Representative: Jason Kerr
Petitioner/Representative: Bret Simons
Date: October 25, 2022

Report: AEG is requesting lane closures and sidewalk closures in multiple locations of their project work areas. This request is to accommodate work on fiber installation via boring and aerial fiber installation. The traffic control would be in place from October 28th through end of project, which we're estimating to be 4 weeks per project area.

AEG has supplied various maintenance of traffic plans for all work. They are also placing door hangers for public notice to property owners about scope of their work and contact information for if there are any issues. (See packet for details.)

AEG is requesting for 4 area projects to be granted through this BPW meeting. The following areas include:

S Park Ridge Rd	North to south, this is between E Saratoga Dr and E 3 rd St West to east, this is between E Saratoga Dr and E Morningside Dr
E Tamarron Dr	North to south, this is between E Tamarron Dr & E Grandview Dr West to east, this is between 10 th St and E Stephenson Dr.
E Janet Dr	North to south, this is between E Ridgewood Dr & S Fenbrook Ln West to east, this is between S Smith Rd and S SR 446
E Discovery Pkwy	North to south, this is between Discovery Pkwy and E Moores Pk West to east, this follows Discovery Pkwy and College Mall Rd



P.O. Box 349 | Buford, Georgia 30515
Main Office: (706)654-2298
www.aeg.cc

To: City of Bloomington – Engineering Department
Subject: City of Bloomington Right of Way Application

Dear Board Members,

Atlantic Engineering Group is planning a large FTTH project across the entire City of Bloomington. This work will take place at different locations throughout the year. In order to facilitate these up coming projects, AEG is respectfully requesting access the to ROW as planned out in the submitted permits.

Traffic control plans will be attached to each permit. No long-term road closures or sidewalk closures are expected. Signs and flaggers will be present when needed and move with the project as it moves throughout the city. The areas will all be identified on the plans we submit to the cities Engineering Department.

Proper door hangers will be placed prior to the construction starting in a particular area. The door hangers will provide information about the construction and contact information if any issues arise.

Bret Simons
Project Coordinator
Atlantic Engineering Group



Good News is Coming to Your Neighborhood!

Highline is excited to announce that Fiber Internet will soon be available in the Grand Junction, Mesa County area! Highline representatives will be working on expanding our state-of-the-art fiber optic network right in your hometown. You may be asking, what exactly is Fiber Internet? Fiber is the fastest and most reliable technology to deliver Internet and Wi-Fi services.

Getting Ready

Before we can begin building, we must determine the location of existing underground utilities such as wires, pipes and water lines. Construction crews will mark out the locations of these utilities and the planned installation paths using colored flags.

Note: *Construction areas will be marked with colored flags and paint. Please feel free to mark any private underground facilities that you feel are in the right of way area (such as sprinkler systems, dog fences, etc.) Please do not remove any flags.*



CITY OF BLOOMINGTON RIGHT-OF-WAY USE PERMIT APPLICATION

401 N Morton Street, Suite 130
P.O. Box 100
Bloomington, IN 47402

Phone: (812) 349-3913
Fax: (812) 349-3520
Email:
engineering@bloomington.in.gov

ROW EXCAVATION ROW USE

ADDRESS OF ROW ACTIVITY: S Park Ridge Rd

A. APPLICANT/AGENT INFORMATION:		D. TRAFFIC CONTROL DEVICES*:	
APPLICANT NAME: <u>Bret Simons</u>		<input checked="" type="checkbox"/> CONES <input type="checkbox"/> ARROWBOARD	
E-MAIL: <u>bret.simons@aeg.cc</u>		<input type="checkbox"/> LIGHTED BARRELS <input checked="" type="checkbox"/> TYPE 3 BARRICADES	
COMPANY: <u>Atlantic Engineering Group</u>		<input checked="" type="checkbox"/> FLAGGERS <input type="checkbox"/> BPD OFFICER	
ADDRESS: <u>P.O. Box 349</u>		*PROVIDING MUTCD COMPLIANT TEMPORARY TRAFFIC CONTROL DEVICES AND MAINTENANCE OF TRAFFIC (MOT) PLAN IS YOUR RESPONSIBILITY AND REQUIRED. See page 3 for additional MOT resources; the graph paper can be used for your MOT site plan if needed or you can submit a separate sheet.	
CITY, STATE, ZIP: <u>Buford, GA 30515</u>			
24-HR EMERGENCY CONTACT NAME: <u>(706)654-2298</u>		E. METERED PARKING SPACES NEEDED: <input type="checkbox"/> Y <input type="checkbox"/> N	
24-HR CONTACT PHONE #: _____		IT IS THE RESPONSIBILITY OF THE APPLICANT TO RESERVE PARKING METER(S) APPLICATION LOCATED: https://bloomington.in.gov/transportation/parking/moving OR CONTACT PARKING SERVICES WITH QUESTIONS AT (812)349-3436	
INSURANCE #*: <u>883724951</u> COMPANY: <u>ACORD</u>		F. IS THIS A <input type="checkbox"/> CBU* <input type="checkbox"/> COUNTY* <input type="checkbox"/> IU* <input type="checkbox"/> NP* PROJECT?	
BOND #*: <u>1160465</u> COMPANY: <u>LEXON</u>		PROJECT NAME: <u>BLC01b-F18 S Park Ridge Rd</u>	
*INSURANCE & BOND MUST BE ON FILE WITH THE CITY BEFORE PERMIT WILL BE ISSUED		PROJECT #: <u>BLC01b-F18 S Park Ridge Rd</u>	
SUBCONTRACTOR INFORMATION		PROJECT MGR.: <u>Lex Mullins</u>	
(LIST ALL COMPANIES WORKING UNDER PRIMARY CONTRACTOR PERMIT)		PROJECT MGR. #: <u>215-847-8819</u>	
COMPANY NAME: _____		*CBU = CITY OF BLOOMINGTON UTILITIES *COUNTY = MONROE COUNTY	
B. WORK DESCRIPTION:		*IU = INDIANA UNIVERSITY *NP = NOT-FOR-PROFIT AGENCY	
<input type="checkbox"/> POD/DUMPSTER <input type="checkbox"/> CRANE <input type="checkbox"/> SCAFFOLDING <input checked="" type="checkbox"/> CONSTRUCTION USE*		G. EXCAVATIONS:	
(EXPLAIN): <u>Excavation</u>		SQ FT OF PAVEMENT* EXCAVATIONS: <u>N/A</u>	
*EXCAVATION, LONG TERM USE FOR STORAGE OF MATERIAL/EQUIPMENT/WALKAROUND		*PAVEMENT INCLUDES: IN OR UNDER CONCRETE, OR ASPHALT INCLUDING CURBS	
C. RIGHT OF WAY TO BE USED/CLOSED:		SQ FT OF NON-PAVEMENT* EXCAVATIONS: <u>66 Sq Ft</u>	
STREET NAME 1: <u>S Park Ridge Rd</u>		*DIRT, GRASS, GRAVEL, LANDSCAPE AREA OR OTHER UNPAVED SURFACE	
1ST INTERSECTING STREET NAME: _____		LINEAL FT OF BORE*: <u>3,006 Lineal Ft</u>	
2ND INTERSECTING STREET NAME: _____		*BORE PITS SHALL BE CALCULATED AS SQ FT EXCAVATIONS	
<input type="checkbox"/> ROAD CLOSURE <input checked="" type="checkbox"/> LANE CLOSURE 1 <input checked="" type="checkbox"/> 2 <input type="checkbox"/> 3 <input type="checkbox"/>		# OF POLE INSTALLATIONS/REMOVAL: <u>N/A</u>	
<input checked="" type="checkbox"/> SIDEWALK* <input type="checkbox"/> BIKE LANE <input type="checkbox"/> OTHER		SQ FT OF SIDEWALK RECONSTRUCTION*: <u>N/A</u>	
TRANSIT STOP? <input type="checkbox"/> Y <input type="checkbox"/> N PARKING LANE(S)** <input type="checkbox"/> Y <input type="checkbox"/> N **NON-METERED		*CONCRETE OR ASPHALT SIDEWALK/PATH BEING IMPROVED/REPLACED	
START DATE: <u>Oct 28th</u> END DATE: _____ # OF DAYS*: <u>30</u>		SQ FT OF SIDEWALK NEW CONSTRUCTION*: <u>N/A</u>	
STREET NAME 2: _____		*CONCRETE OR ASPHALT SIDEWALK/PATH THAT IS NEW INFRASTRUCTURE	
1ST INTERSECTING STREET NAME: _____		#RESIDENTIAL DRIVEWAY INSTALLATION: <u>N/A</u>	
2ND INTERSECTING STREET NAME: _____		 <p>TO SUBMIT A LOCATE REQUEST 24 HRS A DAY, 7 DAYS A WEEK CALL 811 OR 800-382-5544 CALL 2 WORKING DAYS BEFORE YOU DIG. IT'S THE LAW.</p>	
<input type="checkbox"/> ROAD CLOSURE <input type="checkbox"/> LANE CLOSURE 1 <input type="checkbox"/> 2 <input type="checkbox"/> 3 <input type="checkbox"/>			
<input type="checkbox"/> SIDEWALK* <input type="checkbox"/> BIKE LANE <input type="checkbox"/> OTHER		H. INDEMNIFICATION AGREEMENT:	
TRANSIT STOP? <input type="checkbox"/> Y <input type="checkbox"/> N PARKING LANE(S)** <input type="checkbox"/> Y <input type="checkbox"/> N **NON-METERED		The petitioner/applicant hereby agrees to hold harmless, defend and to indemnify the City of Bloomington from or against all claims, action, damages and expenses, including but not limited to reasonable attorney's fees or any alleged injury and/or death to any person or damage to any property arising, or alleged to have arisen out of any act of commission or omission on the part of the petitioner/applicant, his/her heirs, successors, or assigns regardless of whether such acts are the direct or indirect result of the public right-of-way use pursuant to this permit grant.	
START DATE: _____ END DATE: _____ # OF DAYS*: _____		I AFFIRM, UNDER THE PENALTIES FOR PERJURY, THAT THE FOREGOING REPRESENTATIONS ARE TRUE.	
*SIDEWALK CLOSURES FOR A PERIOD OR PERIODS TOTALING 24HRS OR MORE SHALL INSTALL A WALKAROUND UNLESS OTHERWISE APPROVED DURING REVIEW		PRINT NAME: <u>Bret Simons</u>	
STANDARD CLOSURE HOURS MON-FRI*: 9:00 AM - 3:00 PM & 6:00 PM - 9:00 PM		SIGNATURE: <u>Bret Simons</u>	
STANDARD CLOSURE HOURS <input checked="" type="checkbox"/> *NON-STANDARD CLOSURE HOURS <input type="checkbox"/>		DATE: <u>10/5/2022</u>	
REQUESTED CLOSURE HOURS: _____ AM - _____ PM			
*non-standard hours may not be allowed near schools, on arterials, or other circumstances and are subject to approval during the permitting process			
BMC 14.09.040 allows work from 6 AM to 10 PM without violating the noise ordinance (7AM to 9PM for pneumatic hammers)			

For Administration Use Only (applicable to CLOSURE approval)

Approved By: _____ BPW City Engineer Director Date: _____

Staff Representative: _____ Phone#: _____ Date: _____

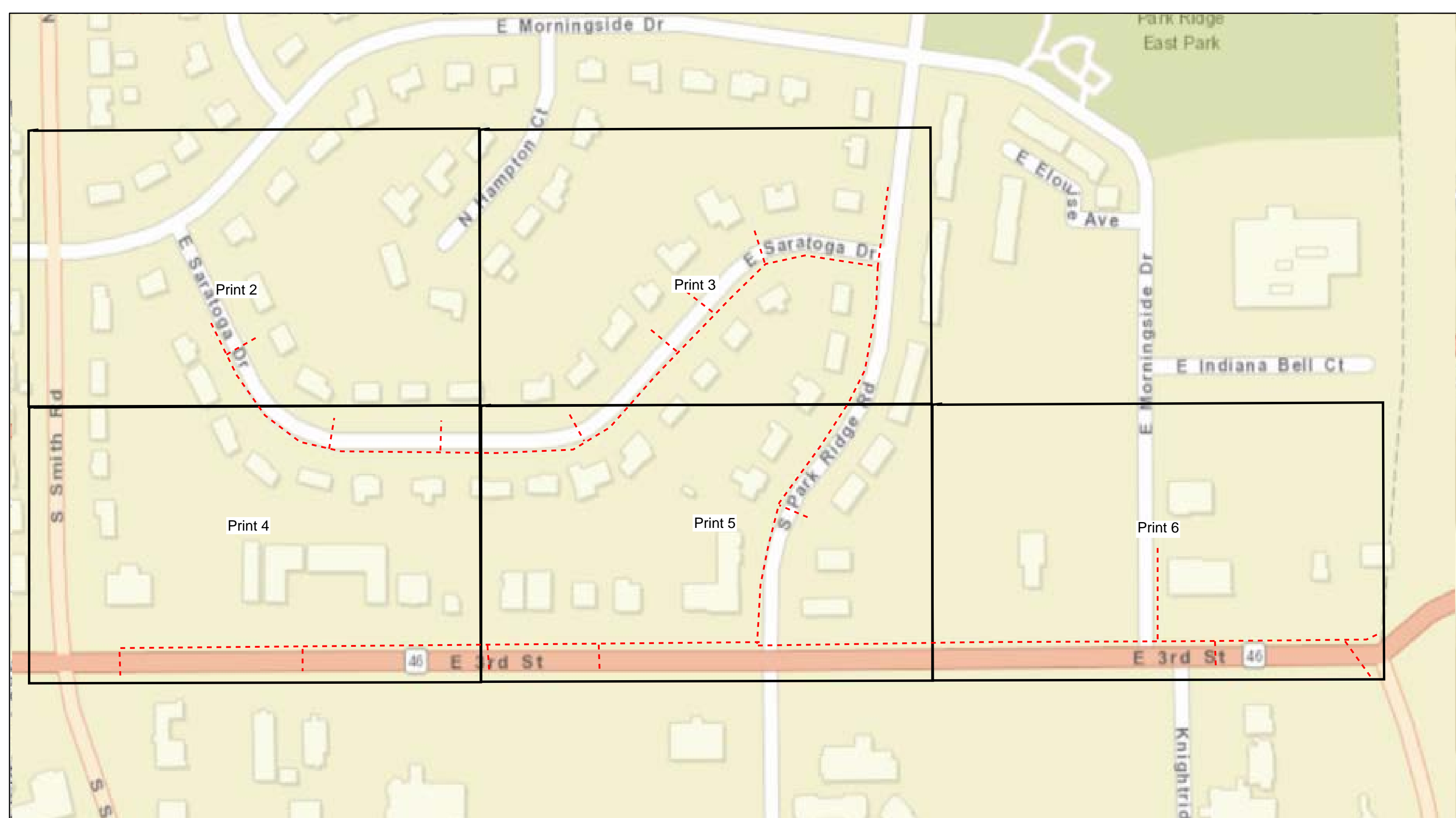

Legend BLC01b-F18 - S Park Ridge Dr

- - - Conduit
- Grids

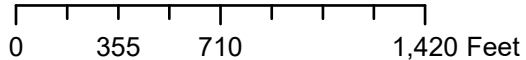

City of Bloomington, IN Permit:
Design View

INI	BY	DATE	DESCRIPTION



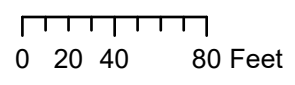
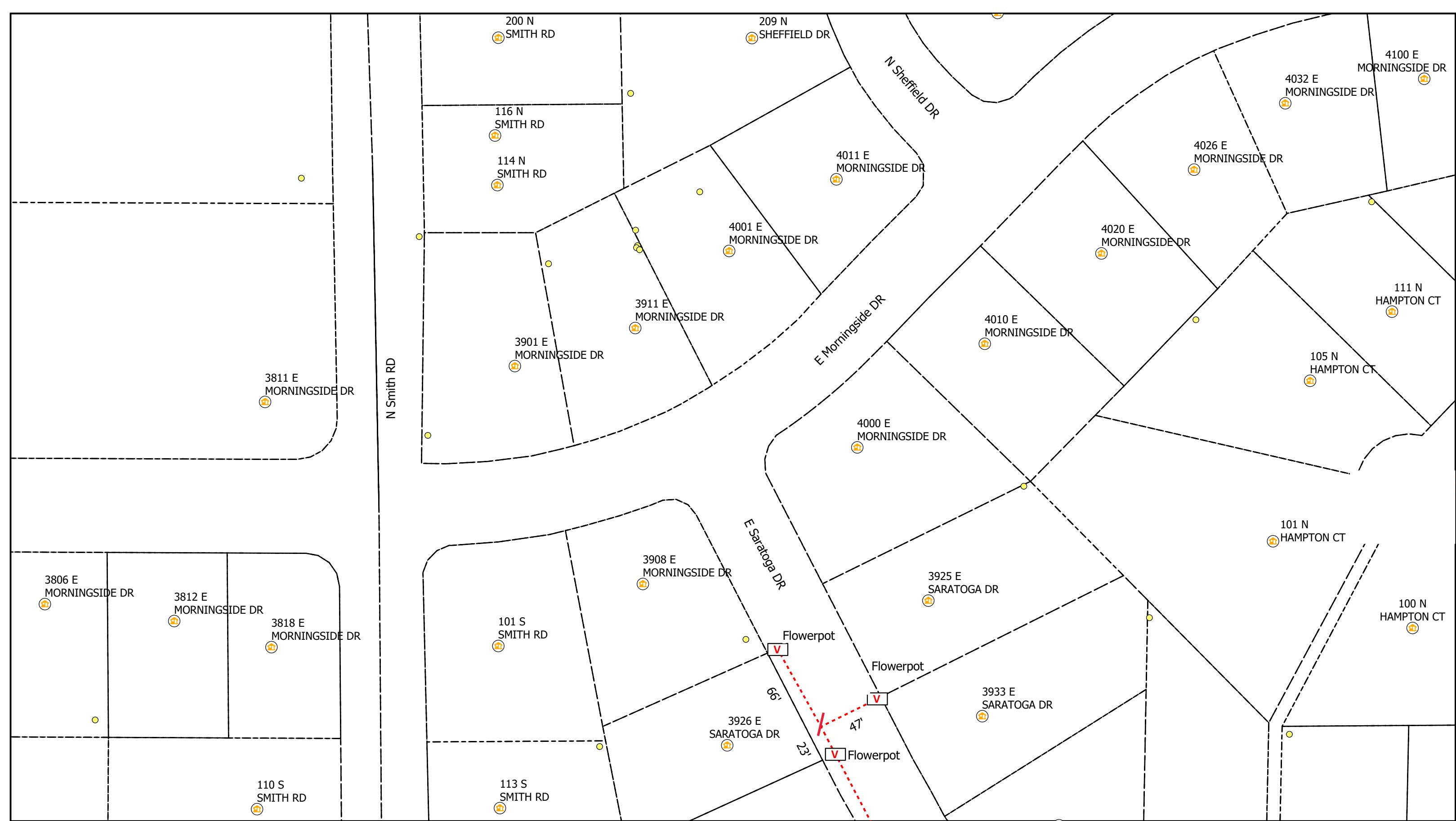

Legend

- Poles
- V Vaults
- Overhead Strand
- Conduit
- Bloomington_Parcels
- R Risers
- Ⓜ Address
- Other Jurisdiction
- Y Anchor
- ← Sidewalk
- Grids

All Flowerpots 12" DIA



City of Bloomington, IN Permit:
Design View

INI	BY	DATE	DESCRIPTION



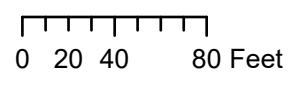
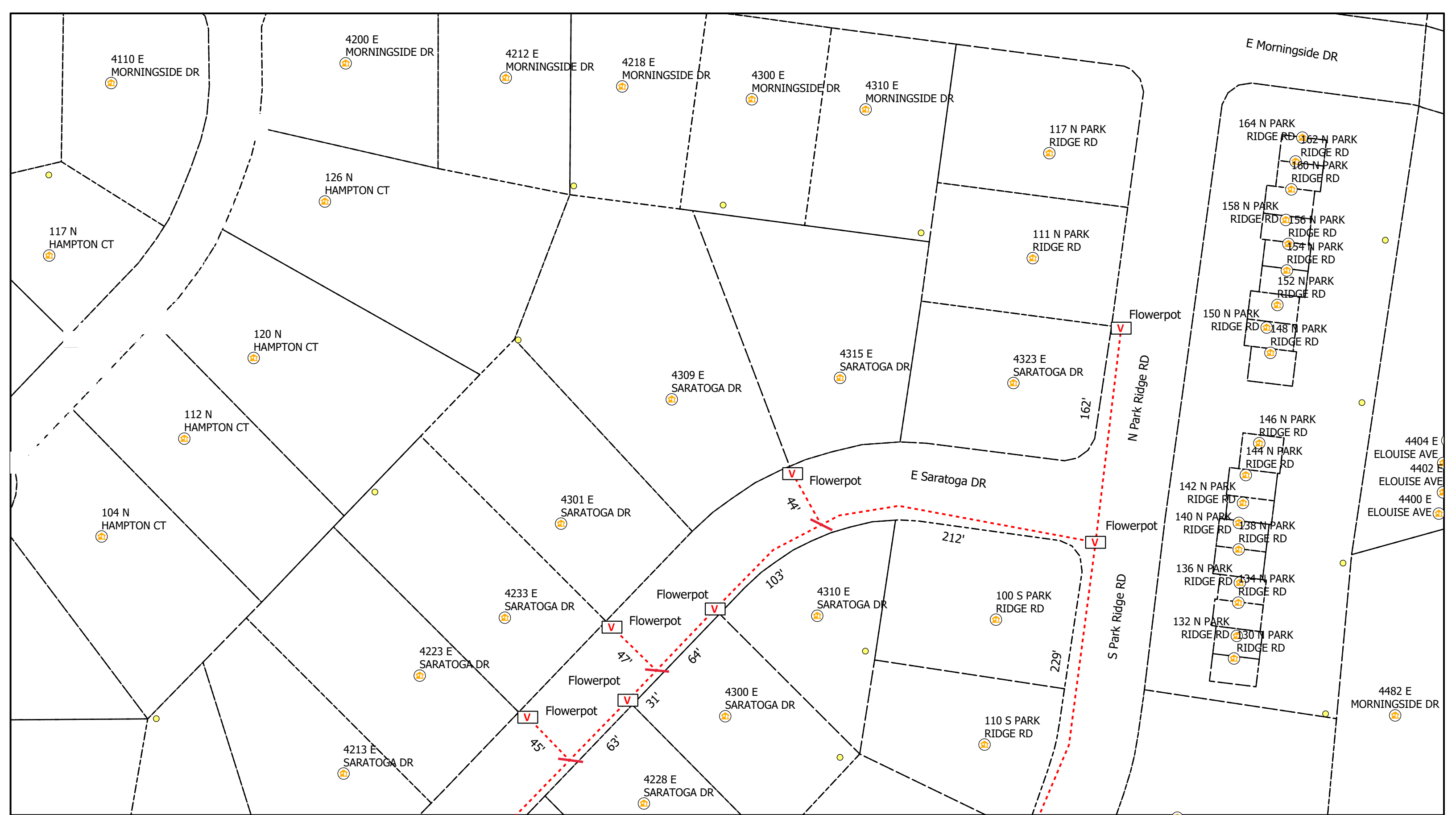

Legend

- Poles
- V Vaults
- Overhead Strand
- Conduit
- Bloomington_Parcels
- R Risers
- Address
- Other Jurisdiction
- Anchor
- Sidewalk
- Grids

All Flowerpots 12" DIA



City of Bloomington, IN Permit:
Design View

INI	BY	DATE	DESCRIPTION



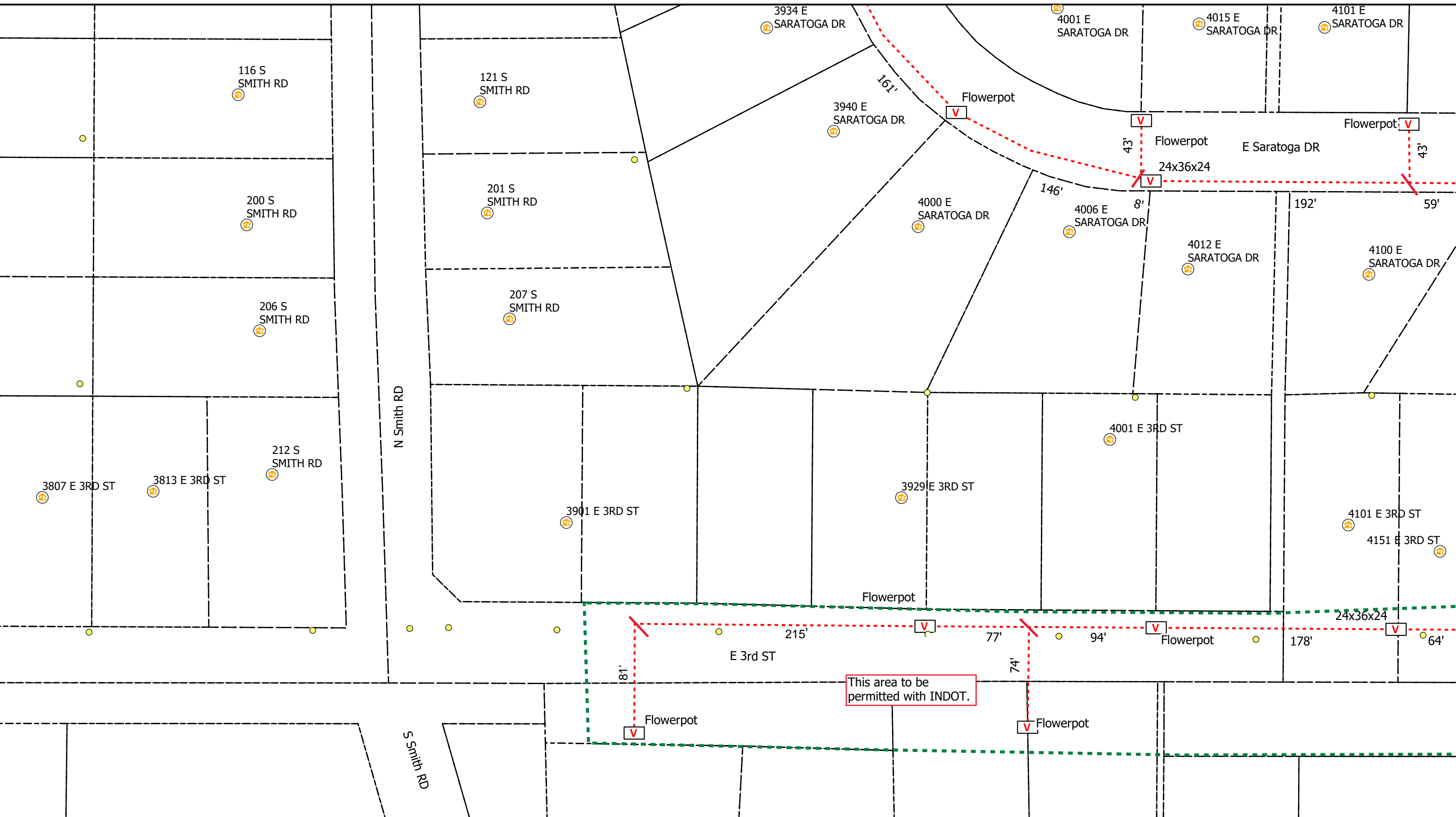

Legend

- Poles
- Vaults
- Overhead Strand
- Conduit
- Bloomington_Parcels
- Risers
- Address
- Other Jurisdiction
- Anchor
- Sidewalk
- Grids

All Flowerpots 12" DIA

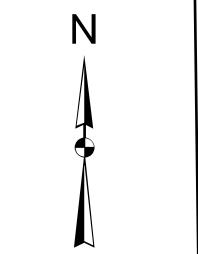

City of Bloomington, IN Permit:
Design View

INI	BY	DATE	DESCRIPTION



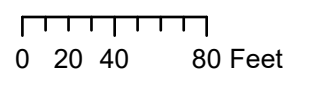
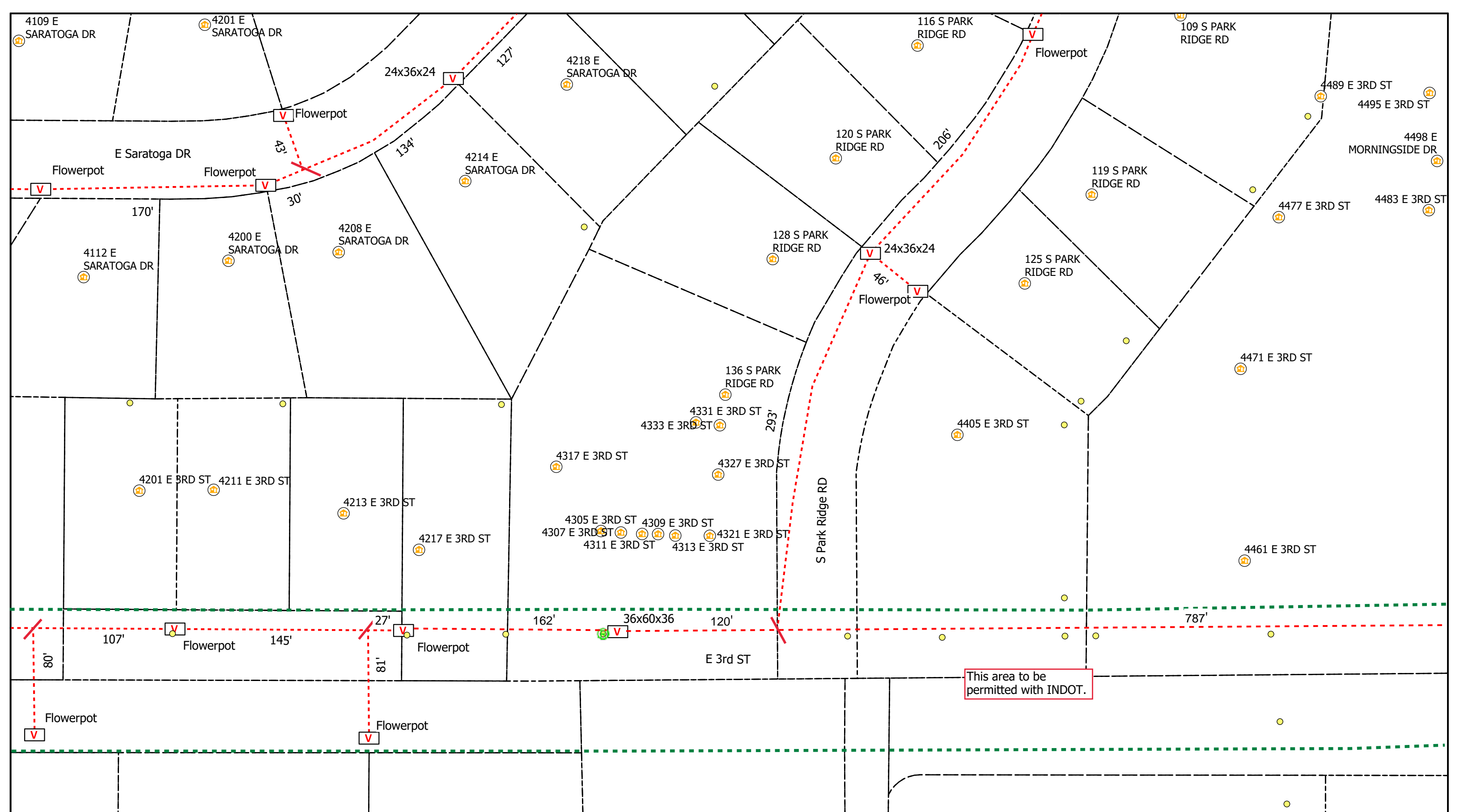

Legend

- Poles
- V Vaults
- Overhead Strand
- - - Conduit
- Bloomington_Parcels
- Ⓡ Risers
- Ⓜ Address
- - - Other Jurisdiction
- Y Anchor
- ← Sidewalk
- Grids

All Flowerpots 12" DIA



City of Bloomington, IN Permit:
Design View

INI	BY	DATE	DESCRIPTION



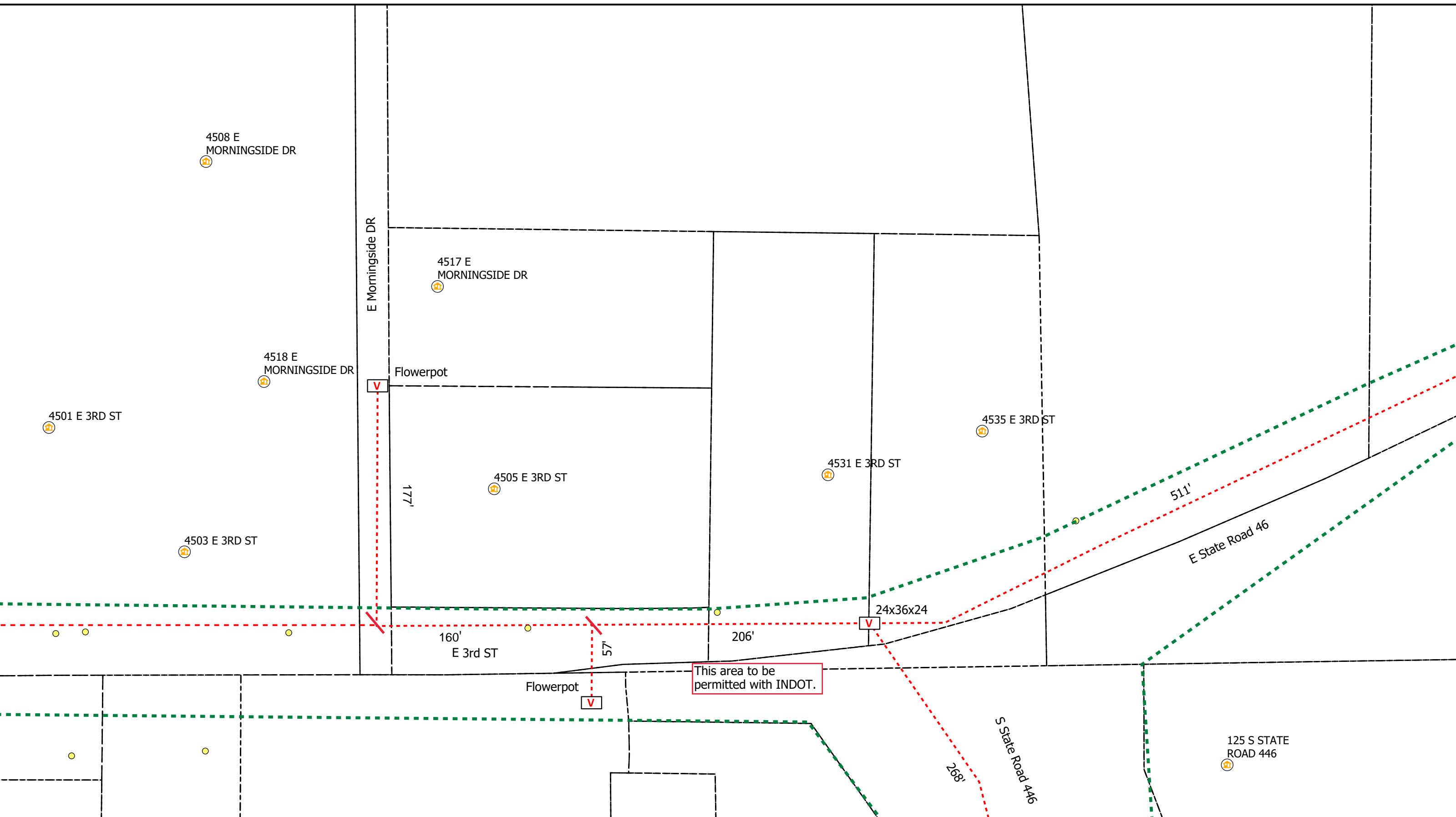

4508 E MORNINGSIDE DR

4517 E MORNINGSIDE DR

4518 E MORNINGSIDE DR

Flowerpot

4501 E 3RD ST

4535 E 3RD ST

4503 E 3RD ST

4505 E 3RD ST

4531 E 3RD ST

177'

511'

E State Road 46

160' E 3rd ST

206'

24x36x24

This area to be permitted with INDOT.

Flowerpot

S State Road 446

268'

125 S STATE ROAD 446

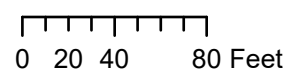

Legend

- Poles
- V Vaults
- Overhead Strand
- - - Conduit
- Bloomington_Parcels
- Ⓡ Risers
- Ⓜ Address
- - - Other Jurisdiction
- Y Anchor
- ← Sidewalk
- Grids

All Flowerpots 12" DIA



City of Bloomington, IN Permit:
Design View

INI	BY	DATE	DESCRIPTION



CONCEPTUAL SIDE VIEW

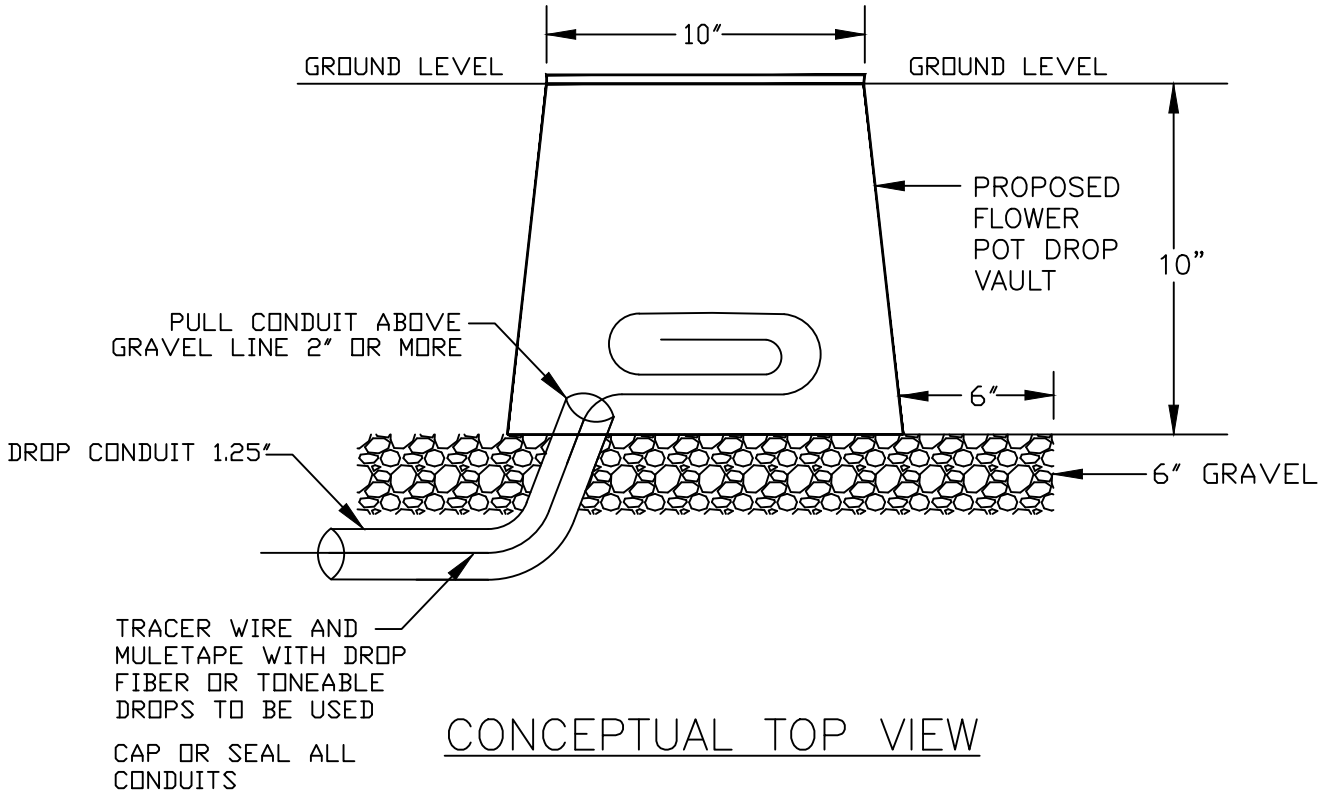

CONCEPTUAL TOP VIEW

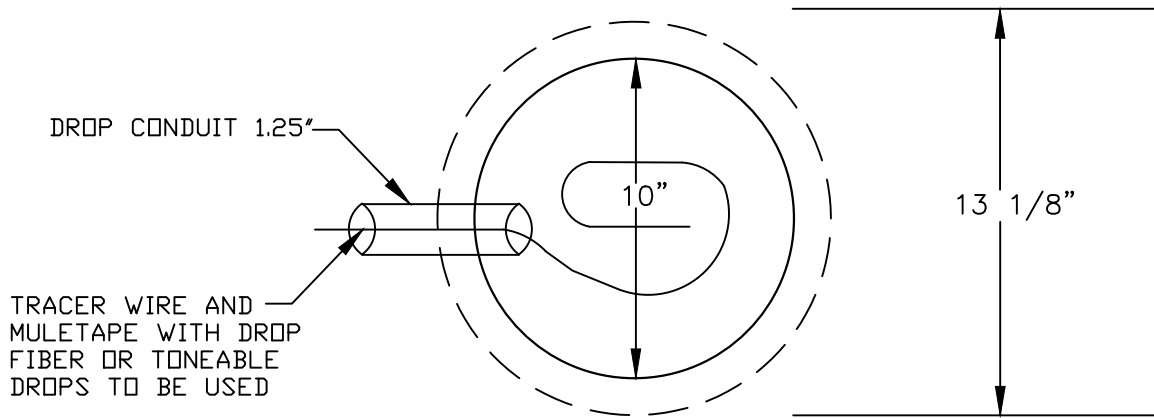

FLOWER POT

30"x48" PC UNIT, 2PC TIER 15/22
 18", 24", and 36" HEIGHT



AMERICAN POLYMER COMPANY

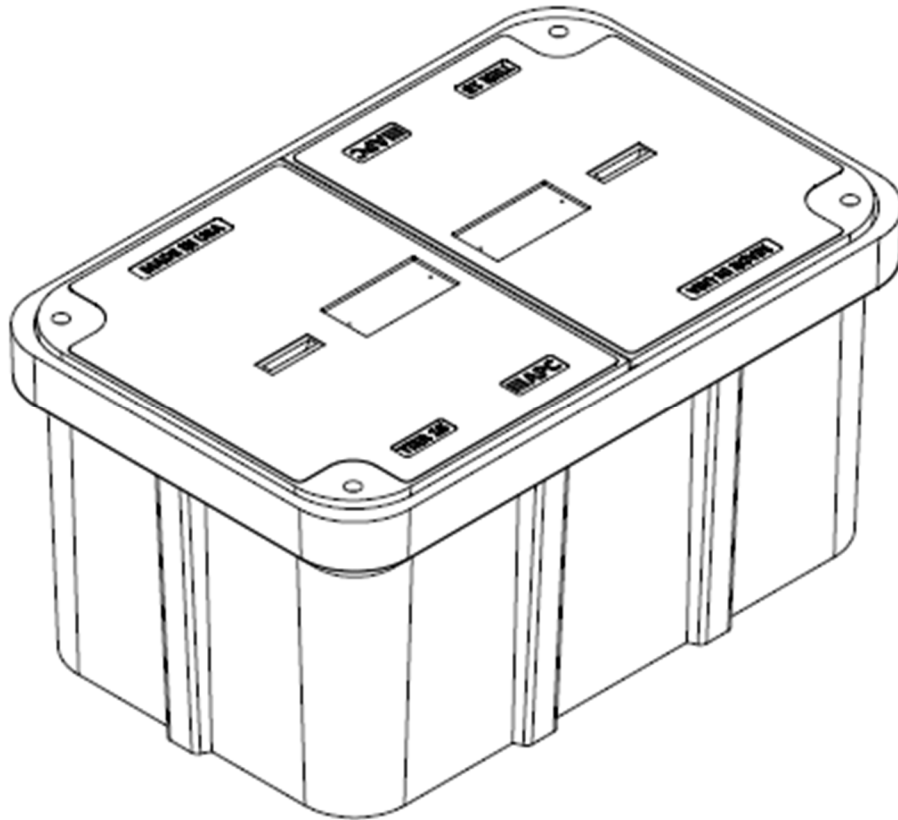

Description	Nominal Size	ANSI Tier	Part Number	Estimated Weight
PC Unit – TIER 15	30"x48"x18"	Tier 15	P304818HU15...	460 lbs.
PC Unit – TIER 22	30"x48"x18"	Tier 22	P304818HU22...	525 lbs.
PC Unit – TIER 15	30"x48"x24"	Tier 15	P304824HU15...	510 lbs.
PC Unit – TIER 22	30"x48"x24"	Tier 22	P304824HU22...	575 lbs.
PC Unit – TIER 15	30"x48"x36"	Tier 15	P304836HU15...	615 lbs.
PC Unit – TIER 22	30"x48"x36"	Tier 22	P304836HU22...	680 lbs.



30"x48" PC UNIT, 2PC TIER 15/22

18", 24", and 36" HEIGHT



AMERICAN POLYMER COMPANY

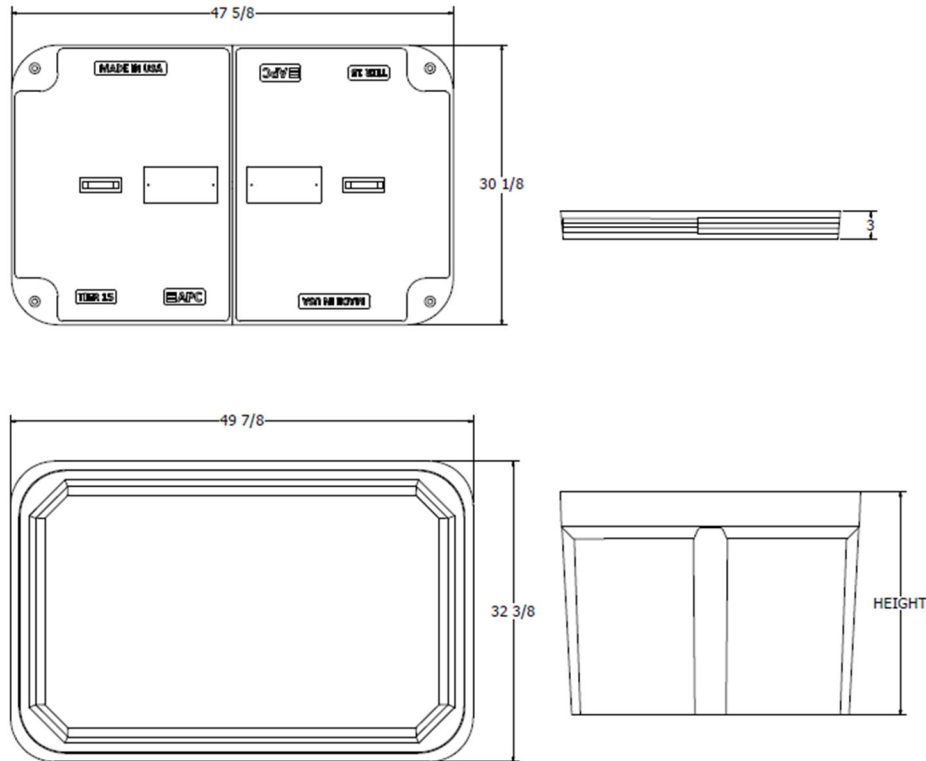

Components	Nominal Size	ANSI Tier	Part Number	Estimated Weight
Replacement Box	30"x48"x18"	Tier 22	P304818B22	185 lbs.
Replacement Box	30"x48"x24"	Tier 22	P304824B22	235 lbs.
Replacement Box	30"x48"x36"	Tier 22	P304836B22	340 lbs.
Replacement Lids - T15	30"x48" (half)	Tier 15	Various	150 lbs.
Replacement Lids - T22	30"x48" (half)	Tier 22	Various	170 lbs.

Bolt options



Machine Thread



Auger Thread



24"x36" PC UNIT, TIER 15/22
 18", 24", 30", and 36" HEIGHT



AMERICAN POLYMER COMPANY

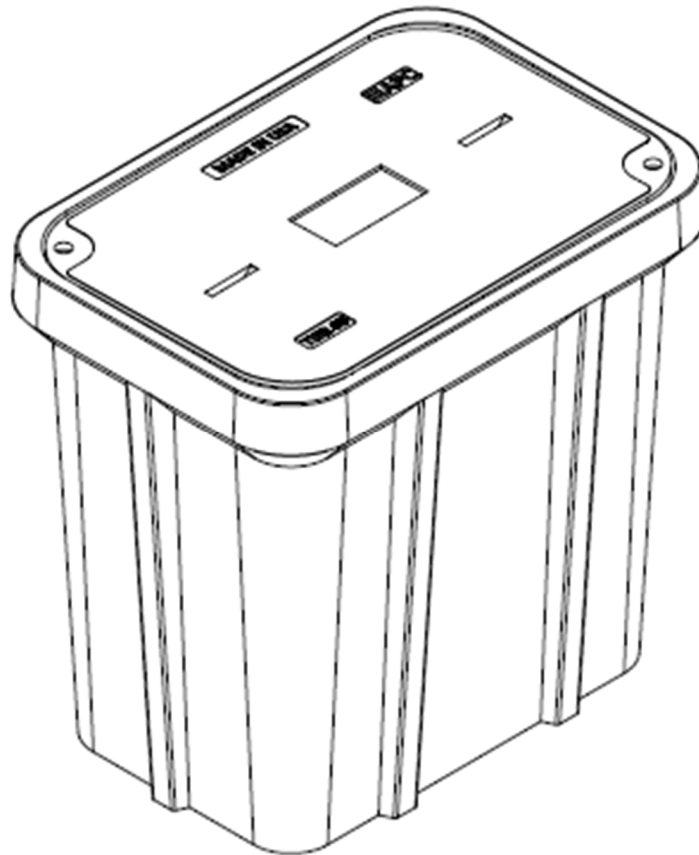

Description	Nominal Size	ANSI Tier	Part Number	Estimated Weight
PC Unit – TIER 15	24x36"x18"	Tier 15	P243618U15...	335 lbs.
PC Unit – TIER 22	24x36"x18"	Tier 22	P243618U22...	355 lbs.
PC Unit – TIER 15	24x36"x24"	Tier 15	P243624U15...	365 lbs.
PC Unit – TIER 22	24x36"x24"	Tier 22	P243624U22...	385 lbs.
PC Unit – TIER 15	24x36"x30"	Tier 15	P243630U15...	395 lbs.
PC Unit – TIER 22	24x36"x30"	Tier 22	P243630U22...	415 lbs.
PC Unit – TIER 15	24x36"x36"	Tier 15	P243636U15...	425 lbs.
PC Unit – TIER 22	24x36"x36"	Tier 22	P243636U22...	445 lbs.



24"x36" PC UNIT, TIER 15/22

18", 24", 30", and 36" HEIGHT



AMERICAN POLYMER COMPANY

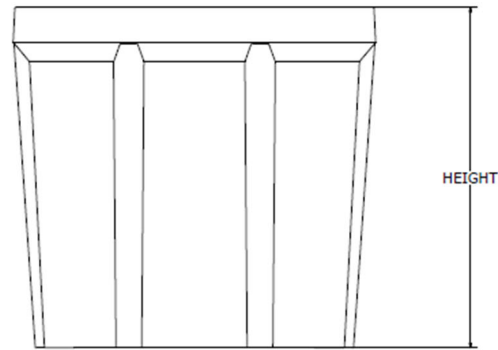
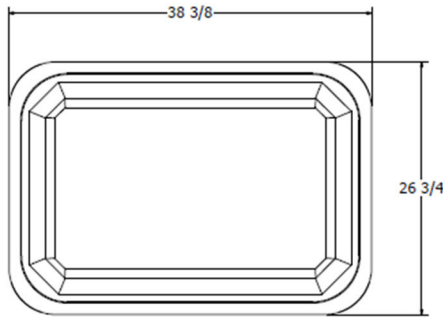
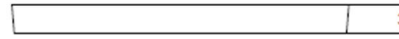
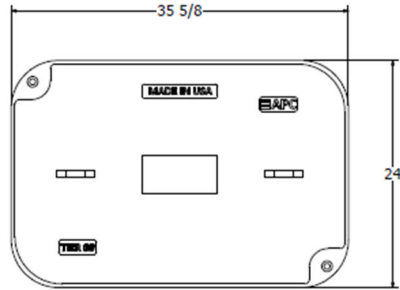

Components	Nominal Size	ANSI Tier	Part Number	Estimated Weight
Replacement Box	24"x36"x18"	Tier 22	P243618B22	165 lbs.
Replacement Box	24"x36"x24"	Tier 22	P243624B22	195 lbs.
Replacement Box	24"x36"x30"	Tier 22	P243630B22	225 lbs.
Replacement Box	24"x36"x36"	Tier 22	P243636B22	255 lbs.
Replacement Lids - T15	24"x36"	Tier 15	Various	170 lbs.
Replacement Lids - T22	24"x36"	Tier 22	Various	190 lbs.

Bolt options

Hex Head



Machine Thread



Penta Head



Auger Thread



17"x30" PC UNIT, TIER 15/22

12", 18", 24", and 30" HEIGHT



AMERICAN POLYMER COMPANY

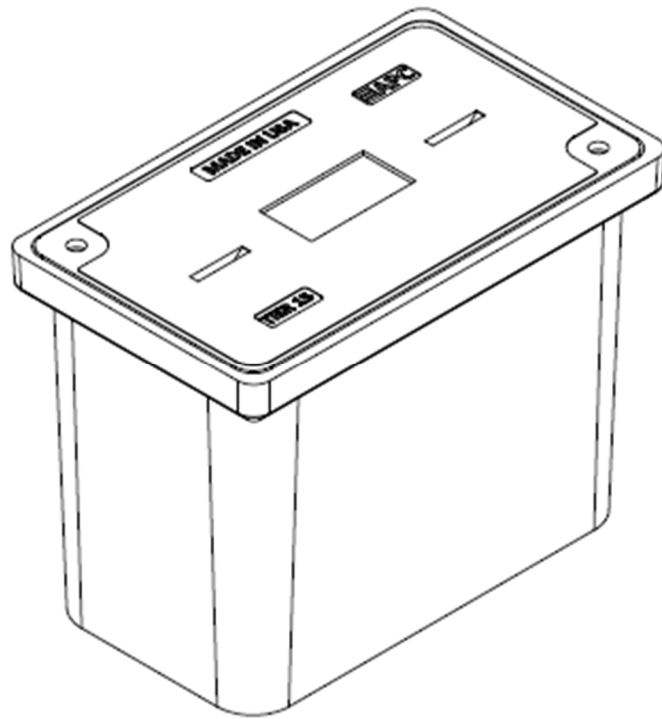

Description	Nominal Size	ANSI Tier	Part Number	Estimated Weight
PC Unit – TIER 15	17"x30"x12"	Tier 15	P173012U15...	138 lbs.
PC Unit – TIER 22	17"x30"x12"	Tier 22	P173012U22...	147 lbs.
PC Unit – TIER 15	17"x30"x18"	Tier 15	P173018U15...	172 lbs.
PC Unit – TIER 22	17"x30"x18"	Tier 22	P173018U22...	181 lbs.
PC Unit – TIER 15	17"x30"x24"	Tier 15	P173024U15...	192 lbs.
PC Unit – TIER 22	17"x30"x24"	Tier 22	P173024U22...	201 lbs.
PC Unit – TIER 15	17"x30"x30"	Tier 15	P173030U15...	217 lbs.
PC Unit – TIER 22	17"x30"x30"	Tier 22	P173030U22...	226 lbs.



17"x30" PC UNIT, TIER 15/22

12", 18", 24", and 30" HEIGHT



AMERICAN POLYMER COMPANY

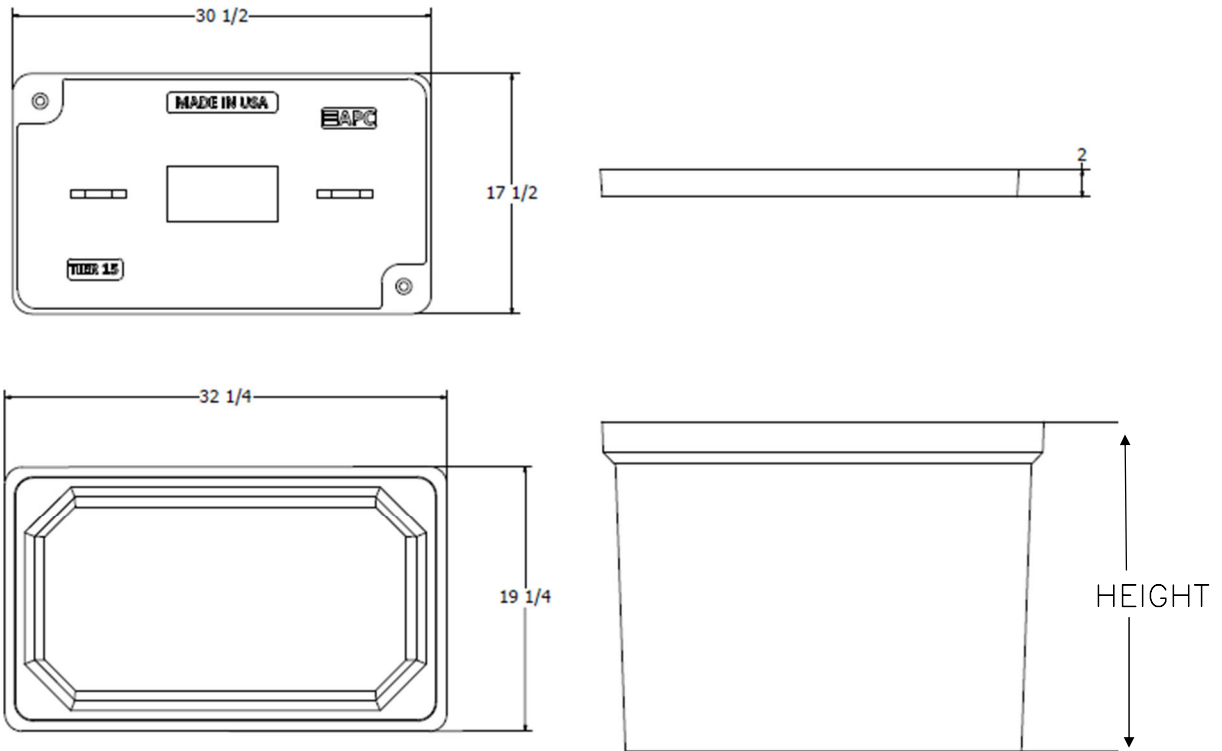

Components	Nominal Size	ANSI Tier	Part Number	Estimated Weight
Replacement Box	17"x30"X12"	Tier 22	P173012B22	66 lbs.
Replacement Box	17"x30"X18"	Tier 22	P173018B22	100 lbs.
Replacement Box	17"x30"X24"	Tier 22	P173024B22	120 lbs.
Replacement Box	17"x30"X30"	Tier 22	P173030B22	145 lbs.
Replacement Lids – T15	17"x30"	Tier 15	Various	72 lbs.
Replacement Lids – T22	17"x30"	Tier 22	Various	81 lbs.

Bolt options



Machine Thread



Auger Thread



33"x60" PC UNIT, 2PC TIER 15/22
36" HEIGHT



AMERICAN POLYMER COMPANY

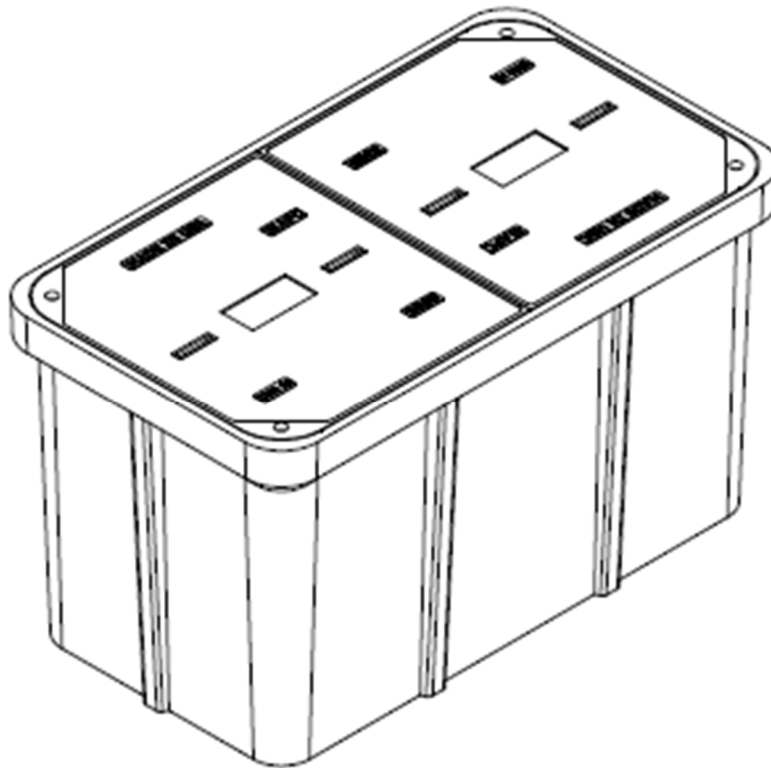

Description	Nominal Size	ANSI Tier	Part Number	Estimated Weight
PC Unit - TIER 15	33"x60"x36"	Tier 15	P336036U15...	930 lbs.
PC Unit - TIER 22	33"x60"x36"	Tier 22	P336036U22...	1030 lbs.



33"x60" PC UNIT, 2PC TIER 15/22

36" HEIGHT



AMERICAN POLYMER COMPANY

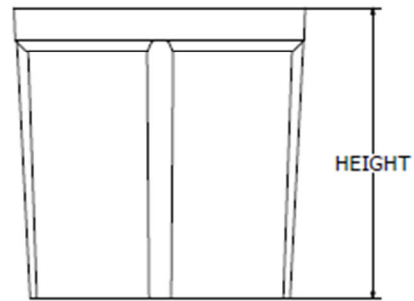
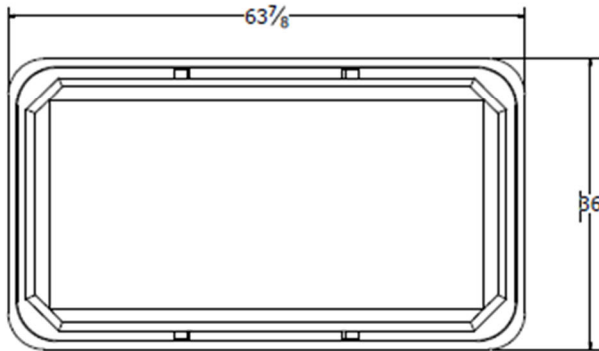
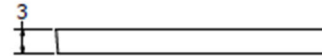

Components	Nominal Size	ANSI Tier	Part Number	Estimated Weight
Replacement Box	33"x60"x36"	Tier 22	P336036B22	530 lbs.
Replacement Lids - T15	33"x60" (half)	Tier 15	Various	200 lbs.
Replacement Lids - T22	33"x60" (half)	Tier 22	Various	250 lbs.

Bolt options

Hex Head



Machine Thread



Penta Head



Auger Thread



Speed (MPH) Prior To Road Work	SIGN SPACING, FT.		Must be Approved by an Engineer				
	Non-Divided Highways	Divided Highways	BUFFER SPACE, FT.	TAPER LENGTH, FT.		CHANNELIZING SPACING, FT.	
			Length	Shoulder (10 ft. Width)	Lane (12 ft. Width)	Through Taper	Through Buffer/Work Area
0-35	200	200	250	70	245	35	50
40-45	350	500	360	150	540	40	80
50-55	500	1000	495	185	660	50	100
60-70	SA-1000, SB-1500, SC-2640 Urban Low Speed - 100 FT		730	235	840	60	120

APPROVED/ACCEPTED BY:
ENGINEER, OWNER, or PRIME CONTRACTOR
 Check for Notice to Proceed.
BLC01b-F18_S Park Ridge Rd - TCP

Signature: _____
Company: _____

Road Runner
Safety Services, Inc.

Date: 10/5/2022 Project: BLC01b-F18 S Park Ridge Rd - TCP :
Traffic Control Suggestion For: AEG :
By: Road Runner Safety Services, Inc. : Nathan

Comments:
Drawing not to scale. Traffic control plan must be approved by an engineer. This is a suggestion only. Road Runners Safety Services, Inc. has no liability for this suggested traffic control plan. Actual placement and spacing of all traffic control devices will depend on field conditions and must conform to MUTCD standards.

- | Manifest | Legend |
|--|------------------|
| 2 x ADA Barricade | ADA Barricade |
| 13 x Channelizer | Channelizer |
| 2 x End Construction | Conduit |
| 2 x Flagger | Flagger (Person) |
| 2 x One Lane Road Ahead | Sign |
| 2 x Road Construction Ahead | Vault |
| 2 x Sidewalk Closed | Vault |
| 2 x Sidewalk Closed Ahead Cross Here (R,L) | Work Area |
| 2 x Vault | |

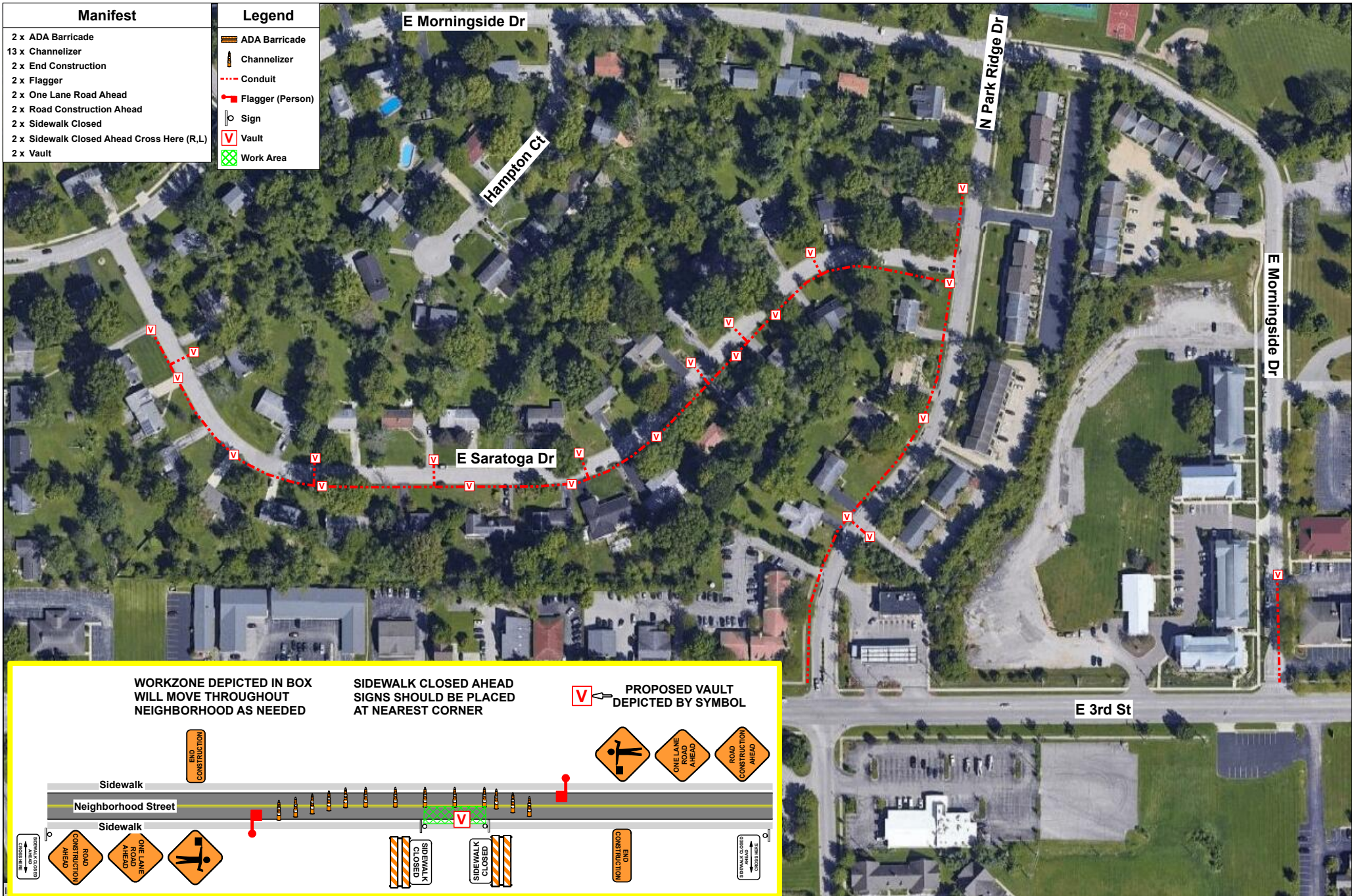

WORKZONE DEPICTED IN BOX
WILL MOVE THROUGHOUT
NEIGHBORHOOD AS NEEDED

SIDEWALK CLOSED AHEAD
SIGNS SHOULD BE PLACED
AT NEAREST CORNER

PROPOSED VAULT
DEPICTED BY SYMBOL

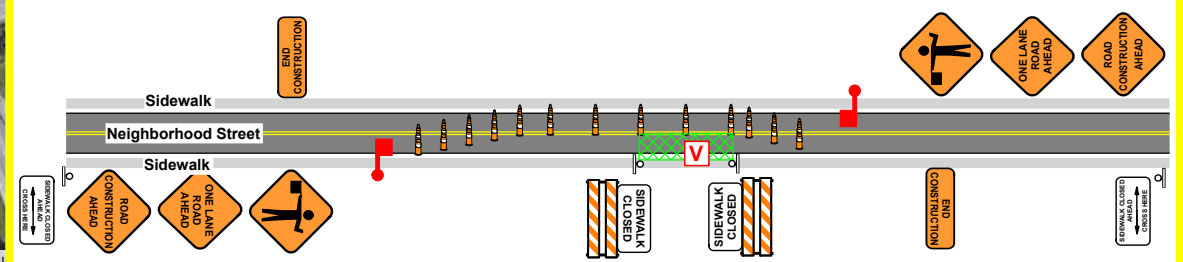



CITY OF BLOOMINGTON

RIGHT-OF-WAY USE PERMIT APPLICATION

401 N Morton Street, Suite 130
P.O. Box 100
Bloomington, IN 47402

Phone: (812) 349-3913
Fax: (812) 349-3520
Email:
engineering@bloomington.in.gov

ROW EXCAVATION ROW USE

ADDRESS OF ROW ACTIVITY: E TAMARRON DR

A. APPLICANT/AGENT INFORMATION:	D. TRAFFIC CONTROL DEVICES*:
APPLICANT NAME: <u>Bret Simons</u>	<input checked="" type="checkbox"/> CONES <input type="checkbox"/> ARROWBOARD
E-MAIL: <u>bret.simons@aeg.cc</u>	<input type="checkbox"/> LIGHTED BARRELS <input checked="" type="checkbox"/> TYPE 3 BARRICADES
COMPANY: <u>Atlantic Engineering Group</u>	<input checked="" type="checkbox"/> FLAGGERS <input type="checkbox"/> BPD OFFICER
ADDRESS: <u>P.O. Box 349</u>	*PROVIDING MUTCD COMPLIANT TEMPORARY TRAFFIC CONTROL DEVICES AND MAINTENANCE OF TRAFFIC (MOT) PLAN IS YOUR RESPONSIBILITY AND REQUIRED. See page 3 for additional MOT resources; the graph paper can be used for your MOT site plan if needed or you can submit a separate sheet.
CITY, STATE, ZIP: <u>Buford, GA 30515</u>	
24-HR EMERGENCY CONTACT NAME: <u>(706)654-2298</u>	E. METERED PARKING SPACES NEEDED: <input type="checkbox"/> Y <input type="checkbox"/> N
24-HR CONTACT PHONE #: _____	IT IS THE RESPONSIBILITY OF THE APPLICANT TO RESERVE PARKING METER(S) APPLICATION LOCATED: https://bloomington.in.gov/transportation/parking/moving OR CONTACT PARKING SERVICES WITH QUESTIONS AT (812)349-3436
INSURANCE #*: <u>883724951</u> COMPANY: <u>ACORD</u>	F. IS THIS A <input type="checkbox"/> CBU* <input type="checkbox"/> COUNTY* <input type="checkbox"/> IU* <input type="checkbox"/> NP* PROJECT?
BOND #: <u>1160465</u> COMPANY: <u>LEXON</u>	PROJECT NAME: <u>BLC01b-F24 E TAMARRON DR</u>
*INSURANCE & BOND MUST BE ON FILE WITH THE CITY BEFORE PERMIT WILL BE ISSUED	PROJECT #: <u>BLC01b-F24 E TAMARRON DR</u>
SUBCONTRACTOR INFORMATION	PROJECT MGR.: <u>Lex Mullins</u>
(LIST ALL COMPANIES WORKING UNDER PRIMARY CONTRACTOR PERMIT)	PROJECT MGR. #: <u>215-847-8819</u>
COMPANY NAME: _____	*CBU = CITY OF BLOOMINGTON UTILITIES *COUNTY = MONROE COUNTY
B. WORK DESCRIPTION:	*IU = INDIANA UNIVERSITY *NP = NOT-FOR-PROFIT AGENCY
<input type="checkbox"/> POD/DUMPSTER <input type="checkbox"/> CRANE <input type="checkbox"/> SCAFFOLDING <input checked="" type="checkbox"/> CONSTRUCTION USE*	G. EXCAVATIONS:
(EXPLAIN): <u>Excavation</u>	SQ FT OF PAVEMENT* EXCAVATIONS : <u>N/A</u>
*EXCAVATION, LONG TERM USE FOR STORAGE OF MATERIAL/EQUIPMENT/WALKAROUND	*PAVEMENT INCLUDES: IN OR UNDER CONCRETE, OR ASPHALT INCLUDING CURBS
C. RIGHT OF WAY TO BE USED/CLOSED:	SQ FT OF NON-PAVEMENT* EXCAVATIONS: <u>648 Sq Ft</u>
STREET NAME 1: <u>E TAMARRON DR</u>	*DIRT, GRASS, GRAVEL, LANDSCAPE AREA OR OTHER UNPAVED SURFACE
1ST INTERSECTING STREET NAME: _____	LINEAL FT OF BORE*: <u>24,647 Lineal Ft</u>
2ND INTERSECTING STREET NAME: _____	*BORE PITS SHALL BE CALCULATED AS SQ FT EXCAVATIONS
<input type="checkbox"/> ROAD CLOSURE <input checked="" type="checkbox"/> LANE CLOSURE 1 <input checked="" type="checkbox"/> 2 <input type="checkbox"/> 3 <input type="checkbox"/>	# OF POLE INSTALLATIONS/REMOVAL: <u>N/A</u>
<input checked="" type="checkbox"/> SIDEWALK* <input type="checkbox"/> BIKE LANE <input type="checkbox"/> OTHER	SQ FT OF SIDEWALK RECONSTRUCTION*: <u>N/A</u>
TRANSIT STOP? <input type="checkbox"/> Y <input type="checkbox"/> N PARKING LANE(S)** <input type="checkbox"/> Y <input type="checkbox"/> N **NON-METERED	*CONCRETE OR ASPHALT SIDEWALK/PATH BEING IMPROVED/REPLACED
START DATE: <u>Oct 28th</u> END DATE: _____ # OF DAYS*: <u>30</u>	SQ FT OF SIDEWALK NEW CONSTRUCTION*: <u>N/A</u>
STREET NAME 2: _____	*CONCRETE OR ASPHALT SIDEWALK/PATH THAT IS NEW INFRASTRUCTURE
1ST INTERSECTING STREET NAME: _____	#RESIDENTIAL DRIVEWAY INSTALLATION: <u>N/A</u>
2ND INTERSECTING STREET NAME: _____	<p>TO SUBMIT A LOCATE REQUEST 24 HRS A DAY, 7 DAYS A WEEK CALL 811 OR 800-382-5544 CALL 2 WORKING DAYS BEFORE YOU DIG. ITS THE LAW.</p>
<input type="checkbox"/> ROAD CLOSURE <input type="checkbox"/> LANE CLOSURE 1 <input type="checkbox"/> 2 <input type="checkbox"/> 3 <input type="checkbox"/>	
<input type="checkbox"/> SIDEWALK* <input type="checkbox"/> BIKE LANE <input type="checkbox"/> OTHER	H. INDEMNIFICATION AGREEMENT:
TRANSIT STOP? <input type="checkbox"/> Y <input type="checkbox"/> N PARKING LANE(S)** <input type="checkbox"/> Y <input type="checkbox"/> N **NON-METERED	The petitioner/applicant hereby agrees to hold harmless, defend and to indemnify the City of Bloomington from or against all claims, action, damages and expenses, including but not limited to reasonable attorney's fees or any alleged injury and/or death to any person or damage to any property arising, or alleged to have arisen out of any act of commission or omission on the part of the petitioner/applicant, his/her heirs, successors, or assigns regardless of whether such acts are the direct or indirect result of the public right-of-way use pursuant to this permit grant.
START DATE: _____ END DATE: _____ # OF DAYS*: _____	I AFFIRM, UNDER THE PENALTIES FOR PERJURY, THAT THE FOREGOING REPRESENTATIONS ARE TRUE.
*SIDEWALK CLOSURES FOR A PERIOD OR PERIODS TOTALING 24HRS OR MORE SHALL INSTALL A WALKAROUND UNLESS OTHERWISE APPROVED DURING REVIEW	PRINT NAME: <u>Bret Simons</u>
STANDARD CLOSURE HOURS MON-FRI*: 9:00 AM - 3:00 PM & 6:00 PM - 9:00 PM	SIGNATURE: <u><i>Bret Simons</i></u>
STANDARD CLOSURE HOURS <input checked="" type="checkbox"/> *NON-STANDARD CLOSURE HOURS <input type="checkbox"/>	DATE: <u>10/5/2022</u>
REQUESTED CLOSURE HOURS: _____ AM - _____ PM	
*non-standard hours may not be allowed near schools, on arterials, or other circumstances and are subject to approval during the permitting process	
BMC 14.09.040 allows work from 6 AM to 10 PM without violating the noise ordinance (7AM to 9PM for pneumatic hammers)	

For Administration Use Only (applicable to CLOSURE approval)

Approved By: _____ BPW City Engineer Director Date: _____

Staff Representative: _____ Phone#: _____ Date: _____

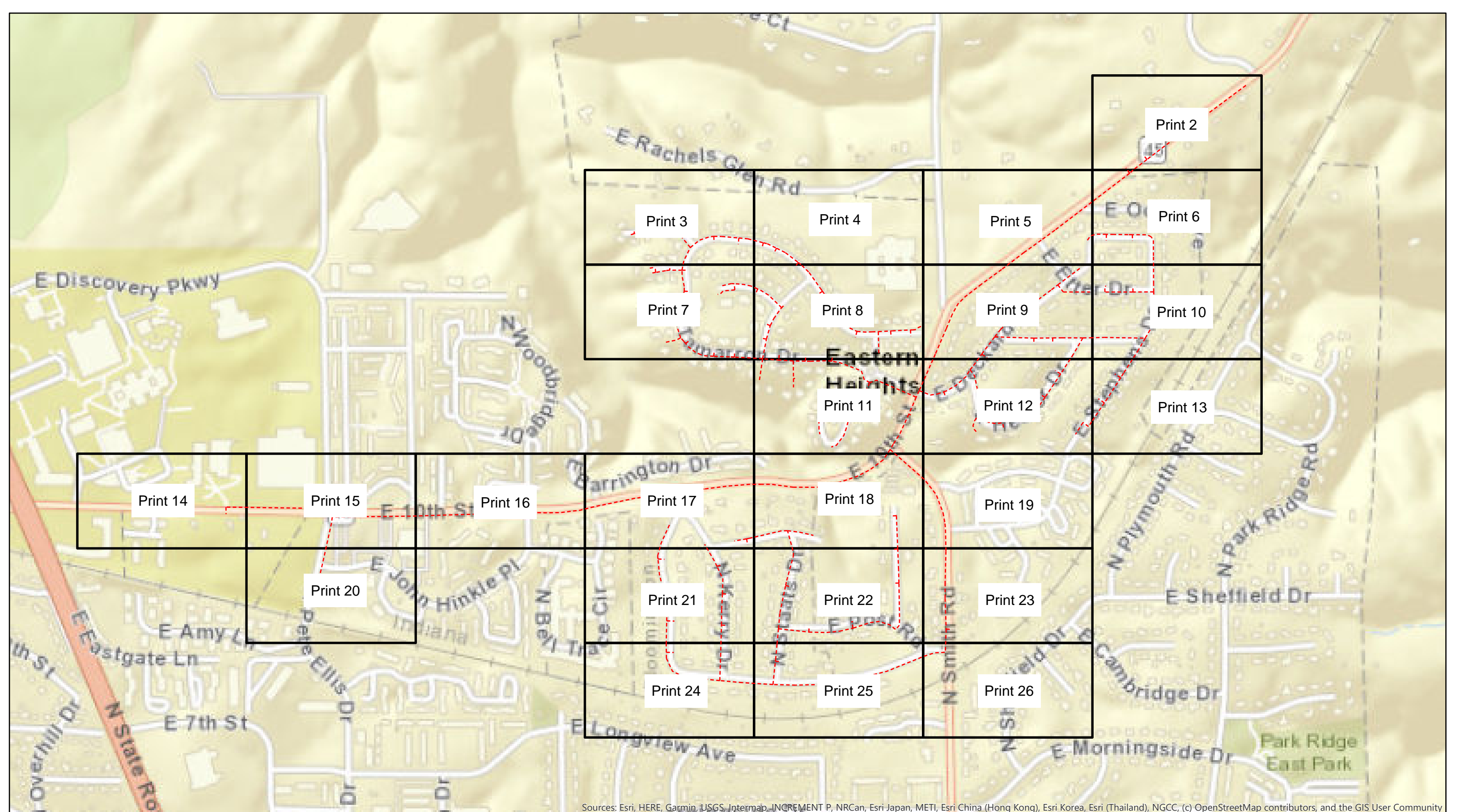

Sources: Esri, HERE, Garmin, USGS, Intermap, INCREMENT P, NRCan, Esri Japan, METI, Esri China (Hong Kong), Esri Korea, Esri (Thailand), NGCC, (c) OpenStreetMap contributors, and the GIS User Community



Legend BLC01b-F24 - E Tamarron Dr

- - - Conduit
- Grids

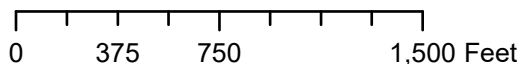

City of Bloomington, IN Permit:
Design View

INI	BY	DATE	DESCRIPTION



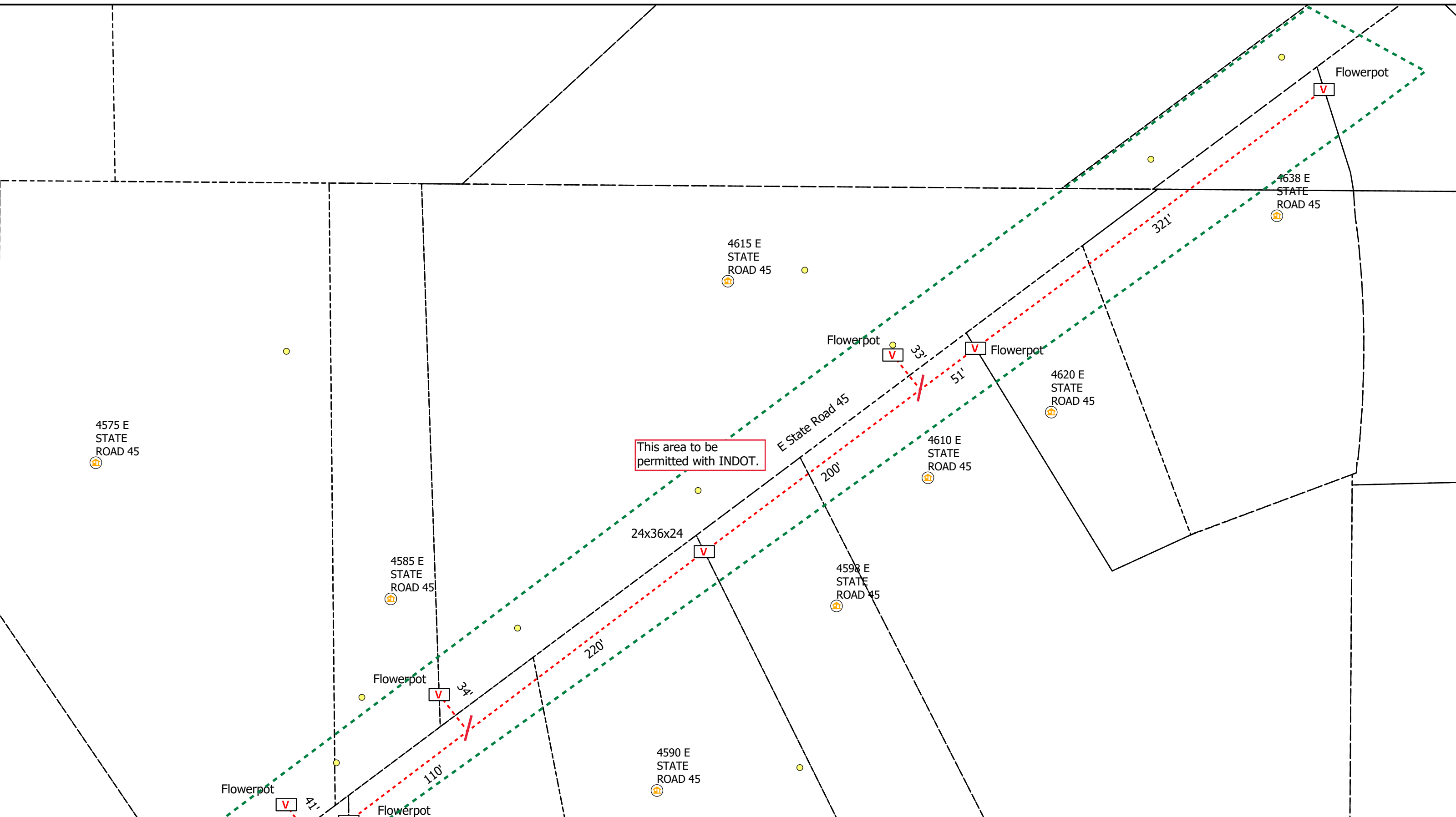

- Legend**
- Poles
 - Risers
 - Sidewalk
 - Vaults
 - Address
 - Grids
 - Conduit
 - Anchor
 - Bloomington_Parcels
 - Other Jurisdiction

All Flowerpots 12" DIA



City of Bloomington, IN Permit:
Design View

INI	BY	DATE	DESCRIPTION



E Rachels Glen RD

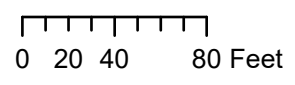
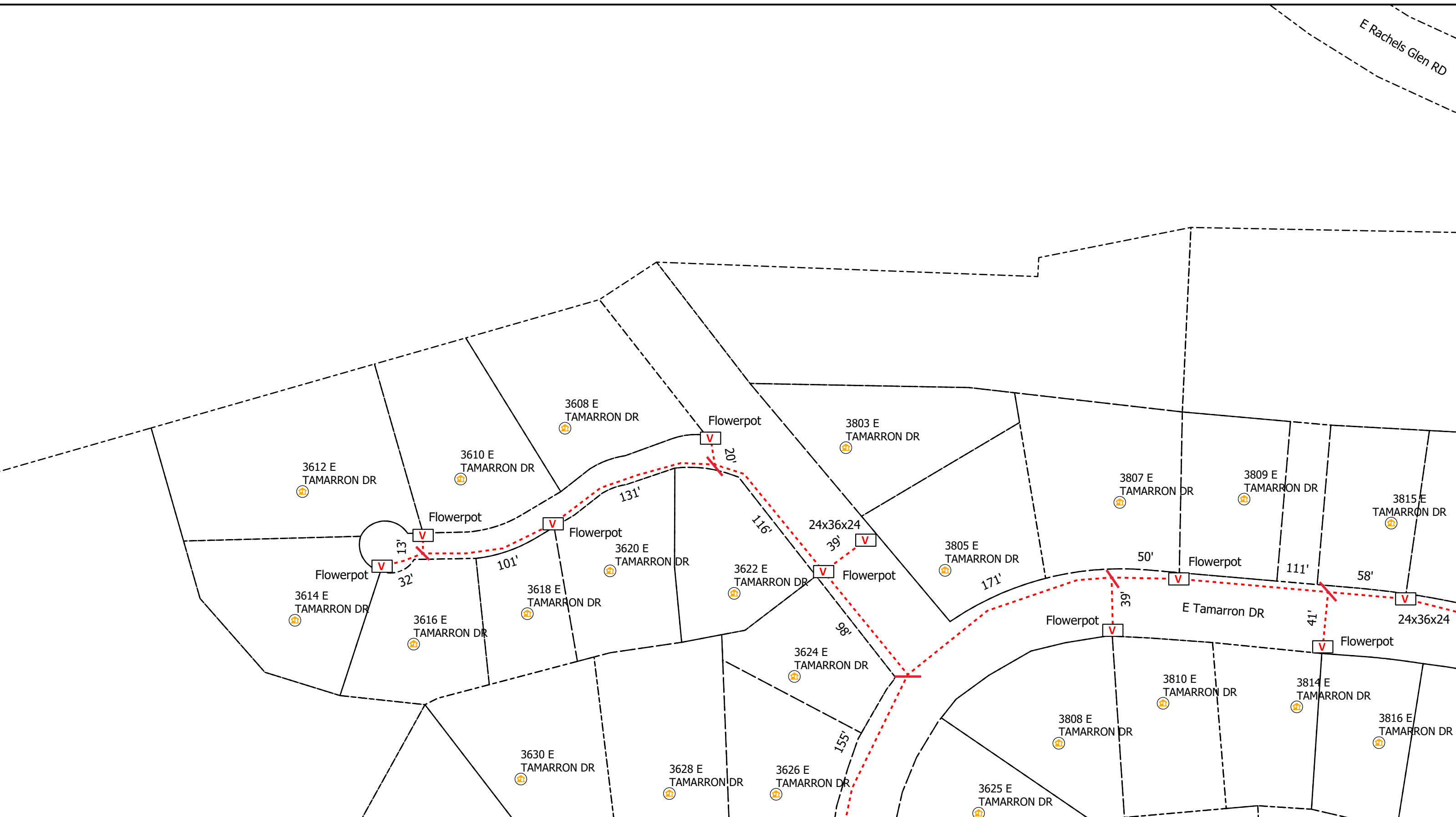

Legend

- Poles
- ⊕ Risers
- V Vaults
- Ⓜ Address
- Conduit
- Y Anchor
- Bloomington_Parcels
- └ Sidewalk
- Grids
- Other Jurisdiction

All Flowerpots 12" DIA



City of Bloomington, IN Permit:
Design View

INI	BY	DATE	DESCRIPTION



E Rachels Glen RD

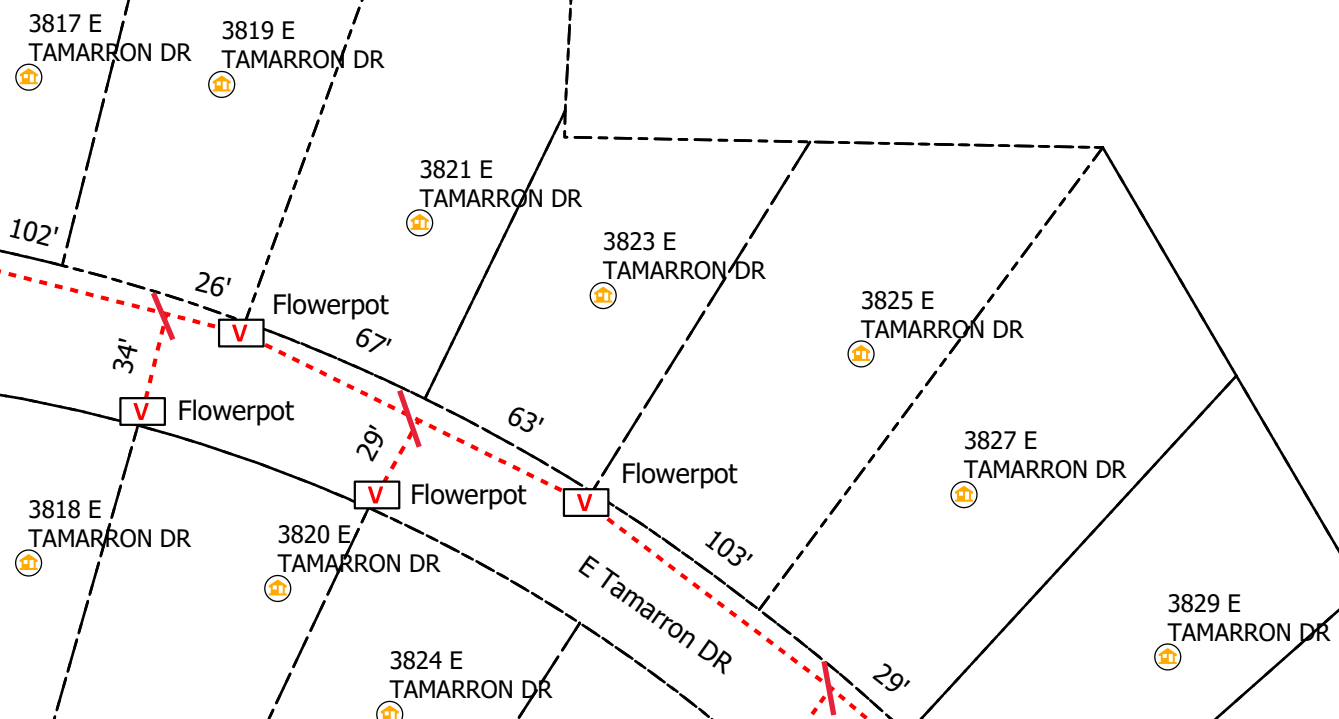

0 20 40 80 Feet

Legend

- Poles
- Vaults
- Bloomington_Parcels
- Risers
- Address
- Anchor
- Sidewalk
- Grids
- Other Jurisdiction

All Flowerpots 12" DIA



City of Bloomington, IN Permit:
Design View

INI	BY	DATE	DESCRIPTION



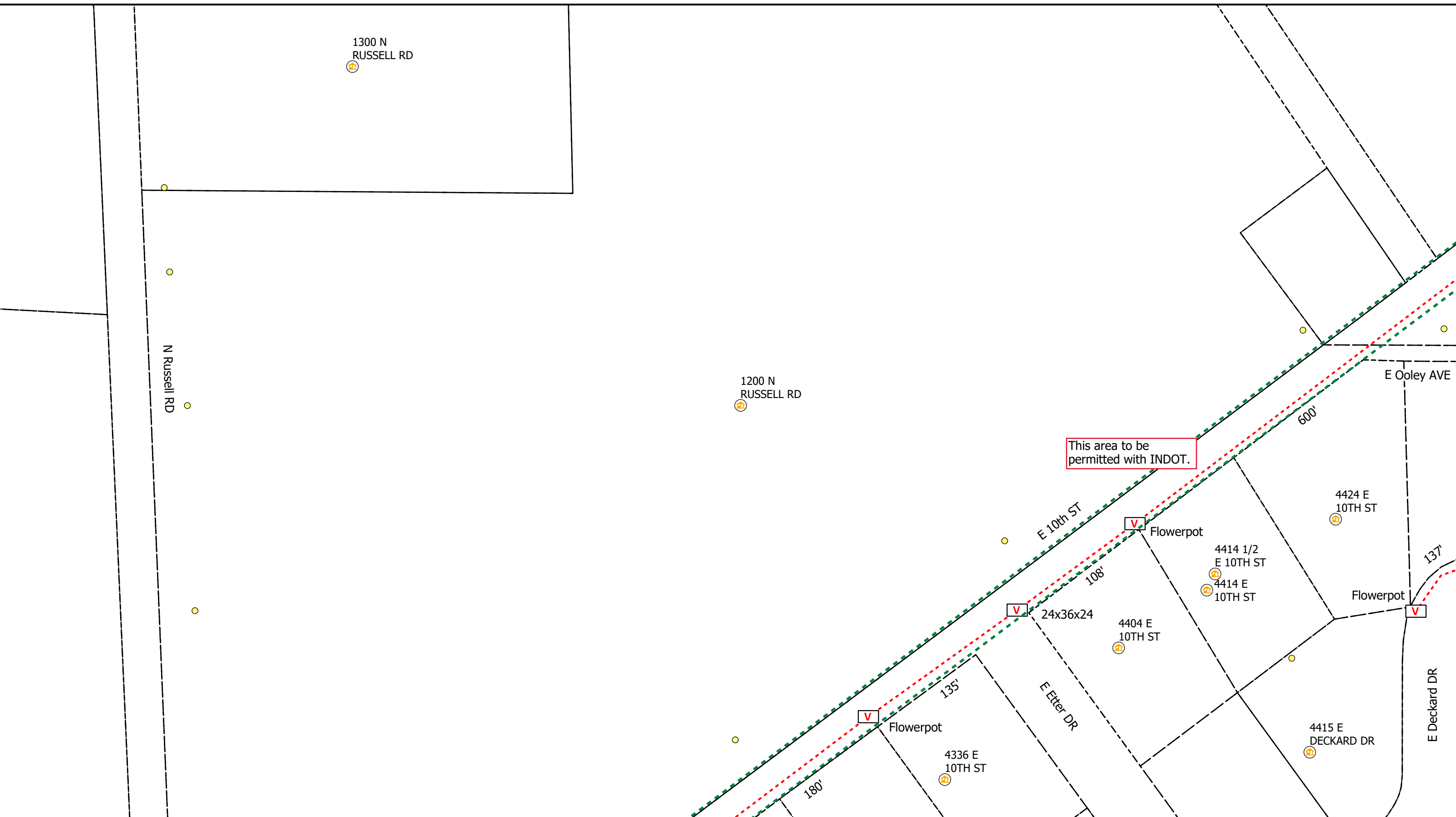

1300 N
RUSSELL RD

1200 N
RUSSELL RD

This area to be
permitted with INDOT.

E Ooley AVE

4424 E
10TH ST

4414 1/2
E 10TH ST

4414 E
10TH ST

4404 E
10TH ST

Flowerpot

E 10th ST

Flowerpot

24x36x24

E Eter DR

4336 E
10TH ST

Flowerpot

4415 E
DECKARD DR

E Deckard DR

N Russell RD

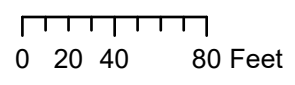

Legend

- Poles
- V Vaults
- - - Conduit
- Bloomington_Parcels
- Ⓡ Risers
- Ⓜ Address
- Y Anchor
- └ Sidewalk
- Grids
- - - Other Jurisdiction

All Flowerpots 12" DIA



City of Bloomington, IN Permit:
Design View

INI	BY	DATE	DESCRIPTION



This area to be permitted with INDOT.

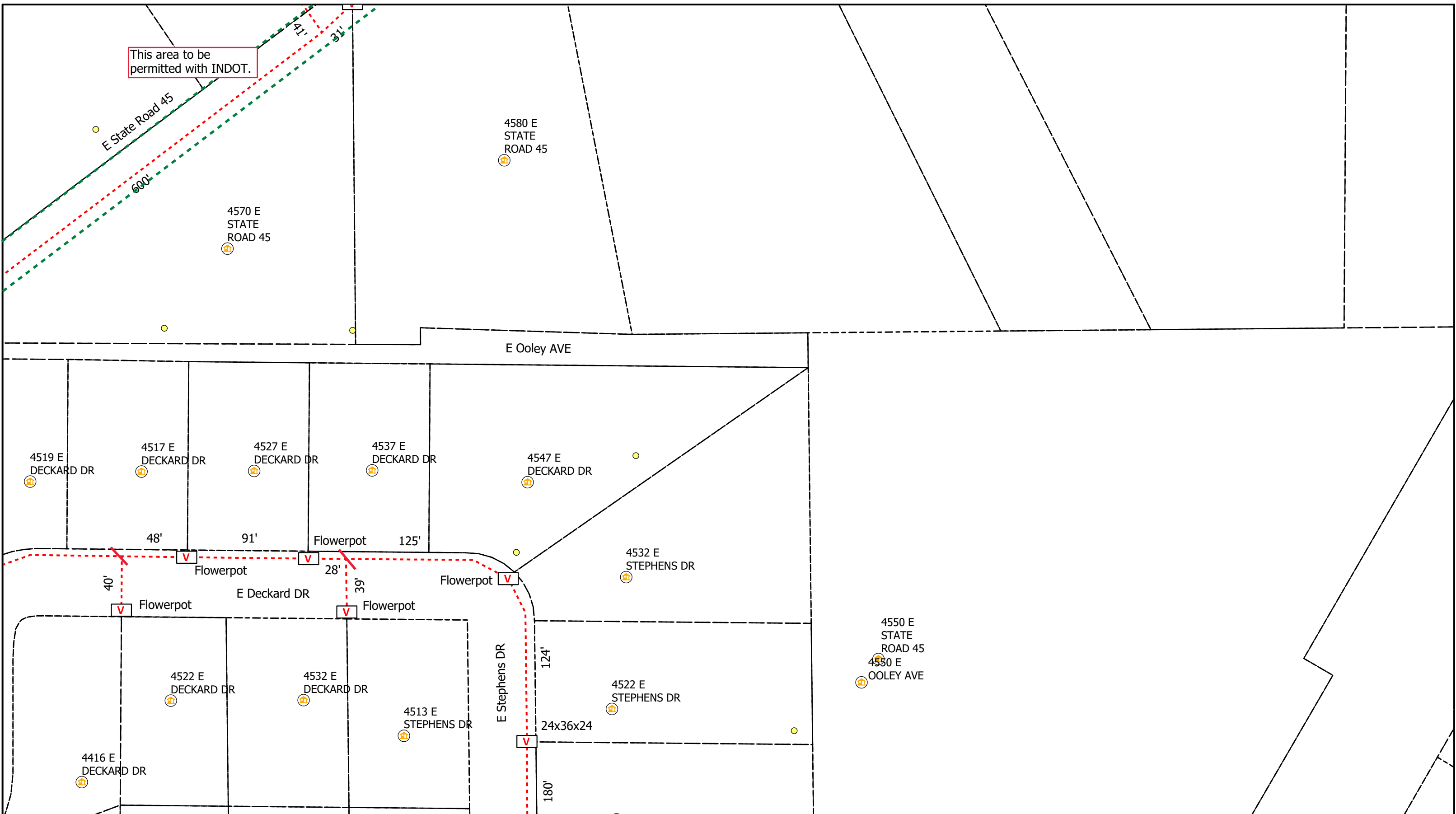

0 20 40 80 Feet

Legend

- Poles
- Risers
- Address
- Anchors
- Vaults
- Flowerpots
- Grids
- Other Jurisdiction
- Conduit
- Sidewalk
- Bloomington_Parcels

All Flowerpots 12" DIA



City of Bloomington, IN Permit:
Design View

INI	BY	DATE	DESCRIPTION



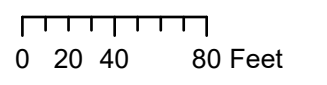
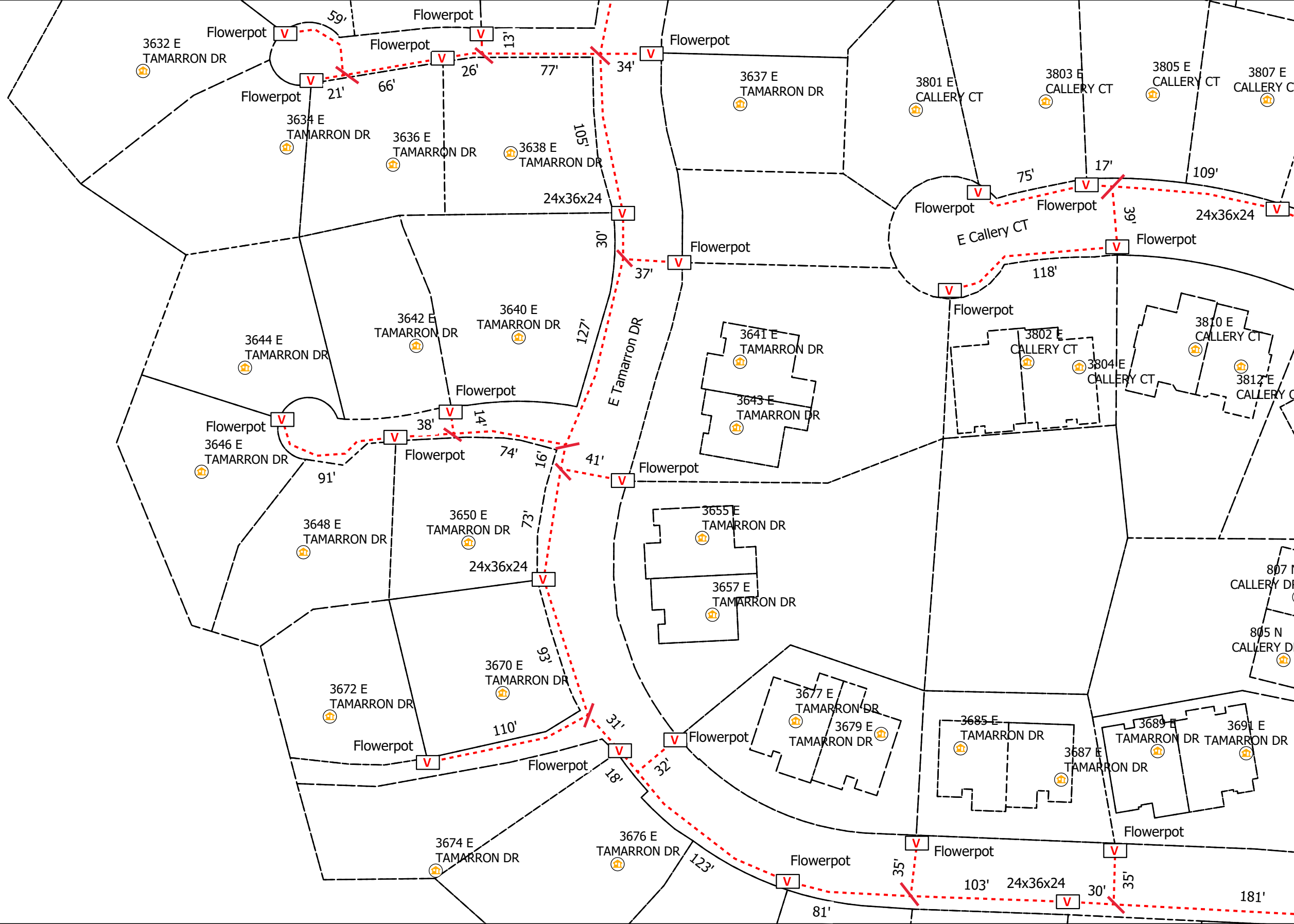

Legend

- Poles
- Ⓡ Risers
- Ⓜ Sidewalk
- V Vaults
- Ⓜ Address
- Y Anchor
- Conduit
- Bloomington_Parcels
- Grids
- Other Jurisdiction

All Flowerpots 12" DIA



City of Bloomington, IN Permit:
Design View

INI	BY	DATE	DESCRIPTION



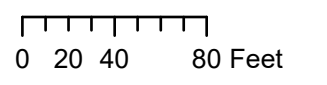
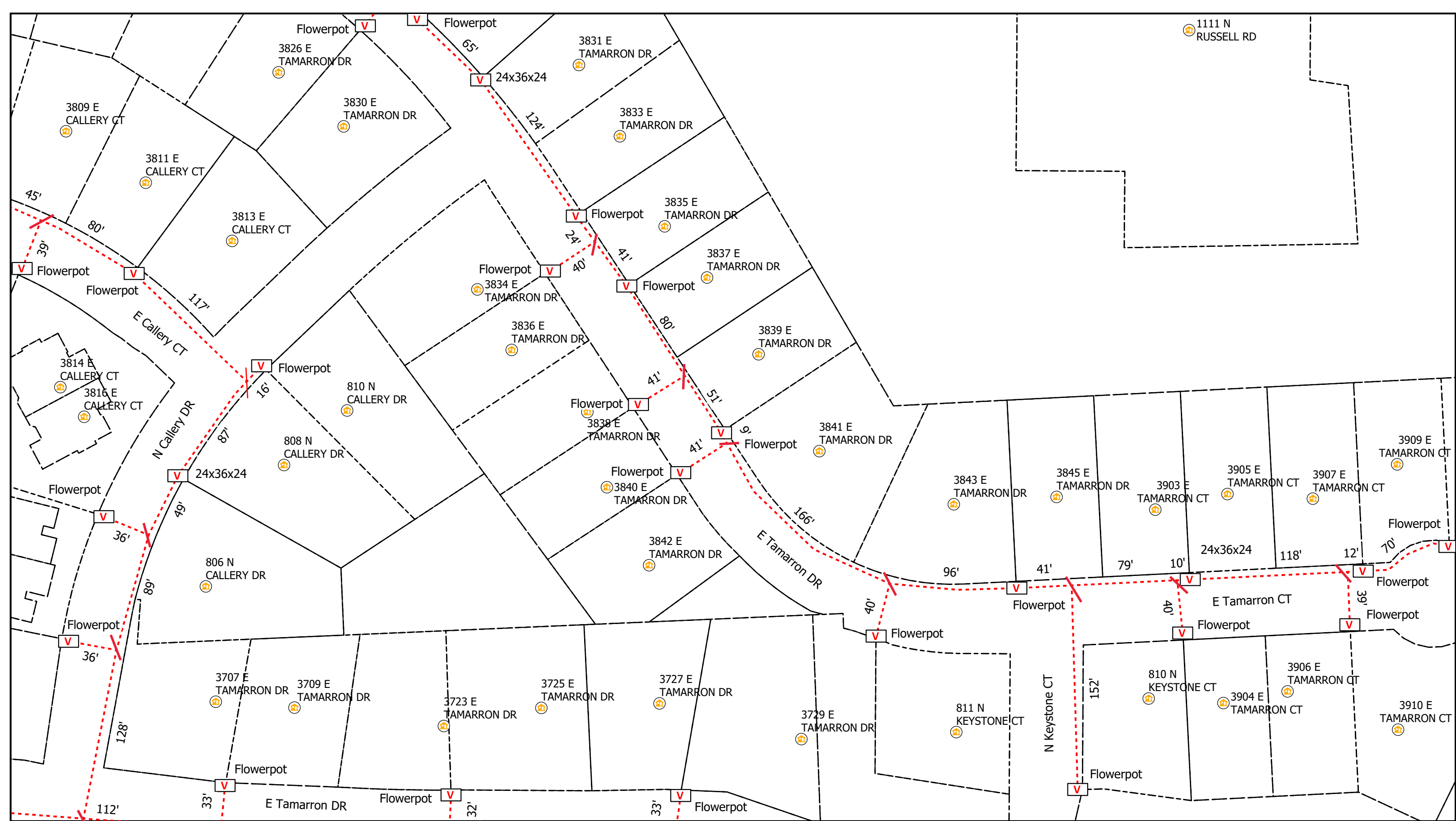

Legend

- Poles
- Risers
- Address
- Vaults
- Anchor
- Sidewalk
- Grids
- Other Jurisdiction
- Bloomington_Parcels

All Flowerpots 12" DIA



City of Bloomington, IN Permit:
Design View

INI	BY	DATE	DESCRIPTION



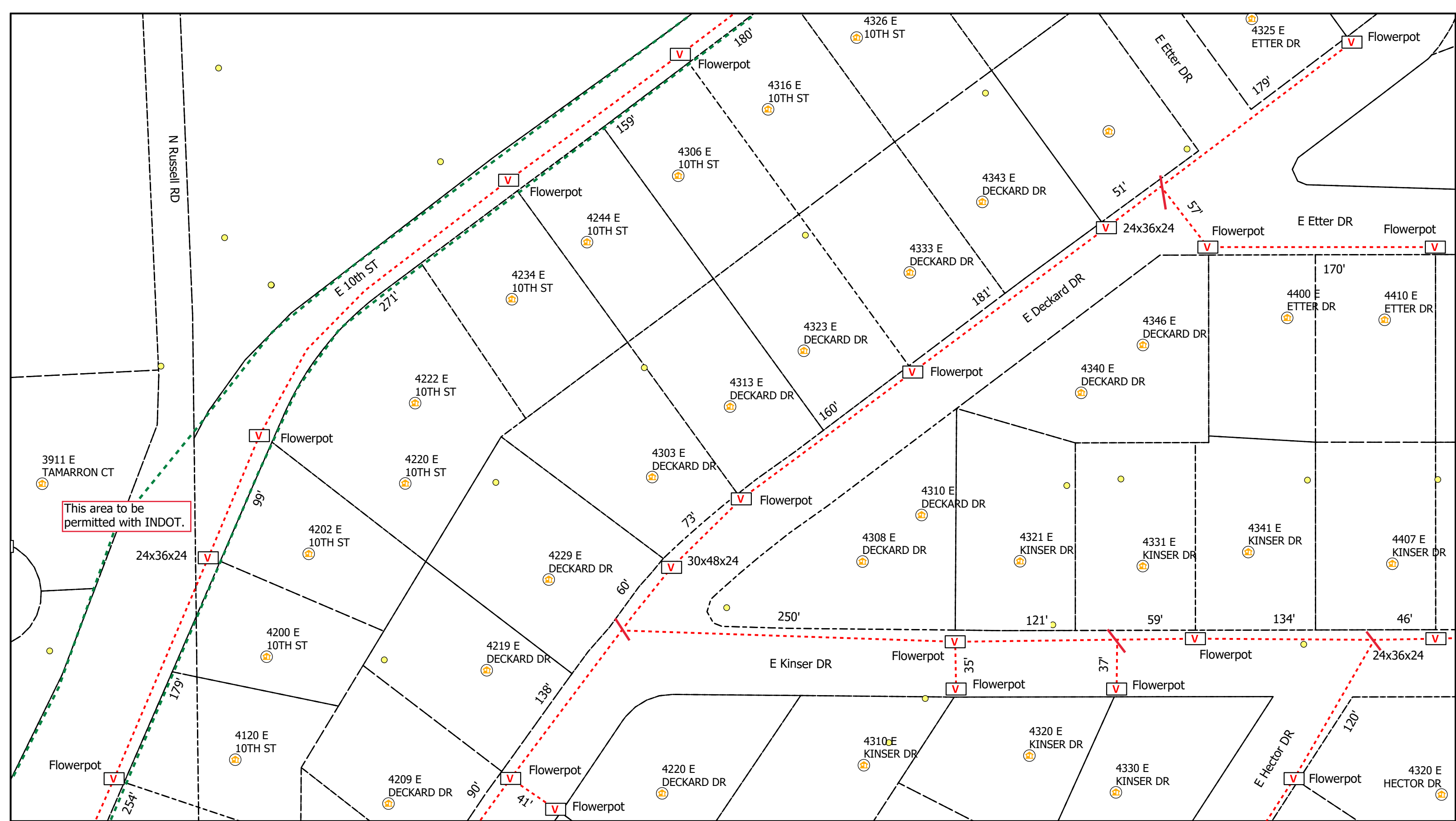

This area to be permitted with INDOT.

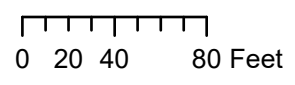

Legend

- Poles
- Ⓡ Risers
- Ⓜ Sidewalk
- V Vaults
- 🏠 Address
- Grids
- Conduit
- Y Anchor
- Bloomington_Parcels
- Other Jurisdiction

All Flowerpots 12" DIA



City of Bloomington, IN Permit:
Design View

INI	BY	DATE	DESCRIPTION



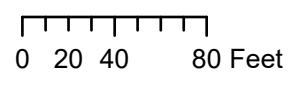
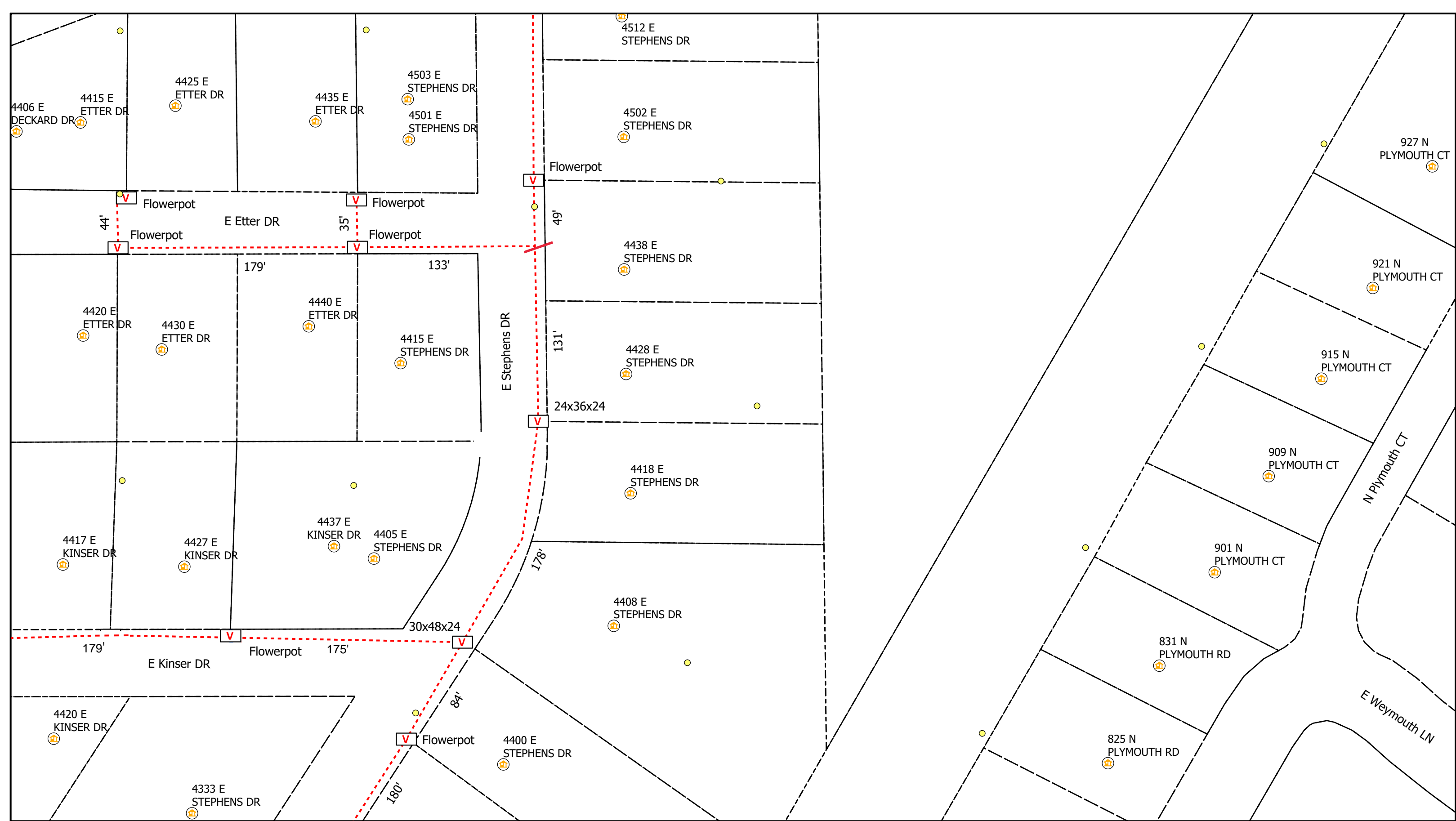

Legend

- Poles
- ⊕ Risers
- ⏏ Sidewalk
- V Vaults
- Ⓜ Address
- Grids
- Conduit
- Y Anchor
- Bloomington_Parcels
- Other Jurisdiction

All Flowerpots 12" DIA



City of Bloomington, IN Permit:
Design View

INI	BY	DATE	DESCRIPTION



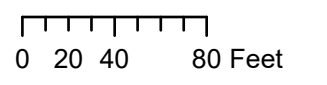
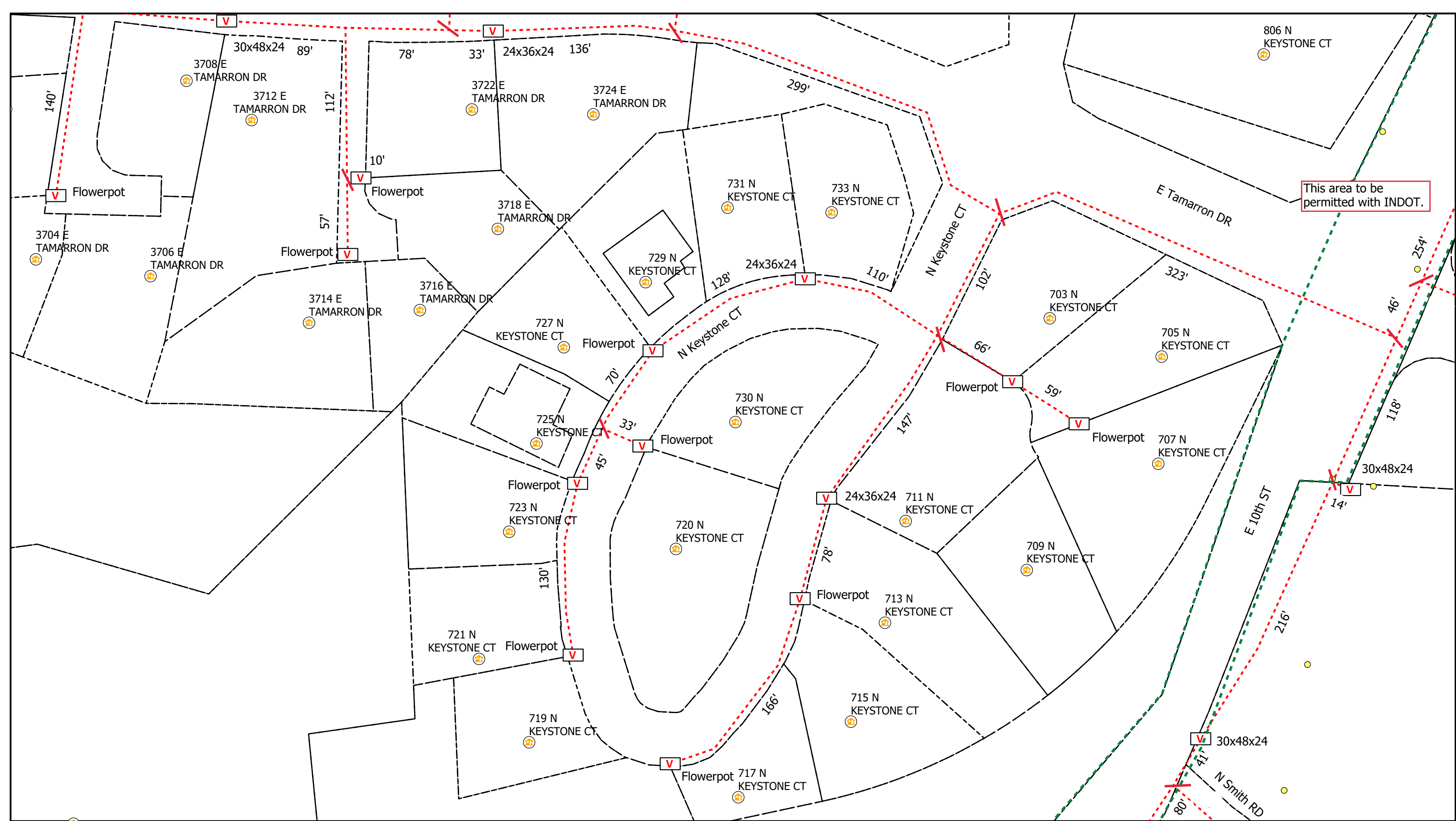

Legend

- Poles
- Ⓡ Risers
- ⏏ Sidewalk
- V Vaults
- Ⓜ Address
- Grids
- Conduit
- Y Anchor
- Bloomington_Parcels
- Other Jurisdiction

All Flowerpots 12" DIA



City of Bloomington, IN Permit:
Design View

INI	BY	DATE	DESCRIPTION



This area to be permitted with INDOT.

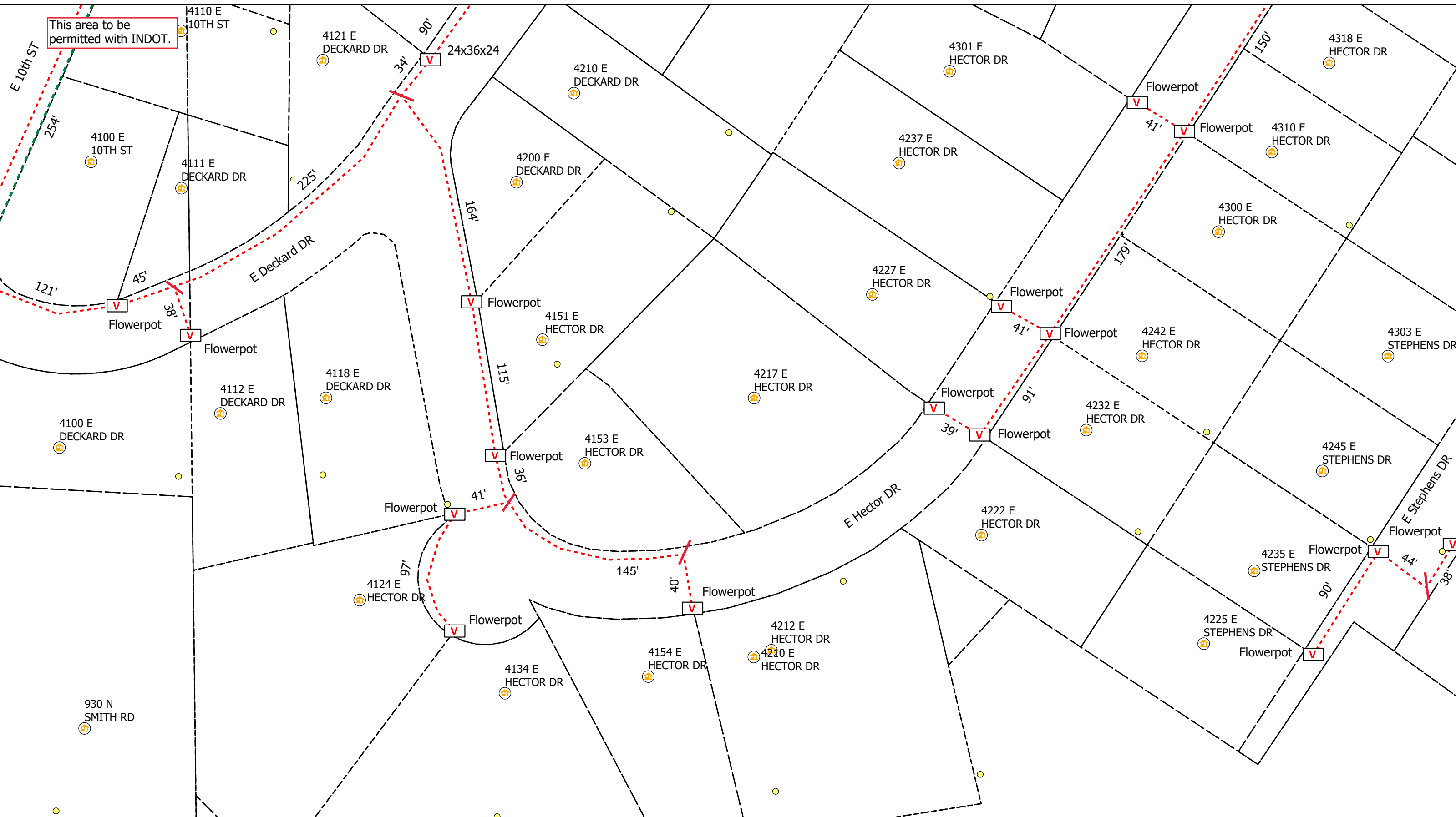

Legend

- Poles
- Vaults
- Bloomington_Parcels
- Risers
- Address
- Anchor
- Sidewalk
- Grids
- Other Jurisdiction

All Flowerpots 12" DIA



City of Bloomington, IN Permit:
Design View

INI	BY	DATE	DESCRIPTION



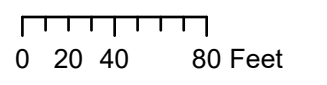

Legend

- Poles
- Ⓡ Risers
- ⚡ Sidewalk
- V Vaults
- 🏠 Address
- Grids
- Conduit
- Y Anchor
- Bloomington_Parcels
- Other Jurisdiction

All Flowerpots 12" DIA



City of Bloomington, IN Permit:
Design View

INI	BY	DATE	DESCRIPTION



2815 E
10TH ST

2719 E
10TH ST

This area to be
permitted with INDOT.

678'

E 10th ST

V 24x36x24

45'

2654 E
10TH ST

2652 E
10TH ST

2648 E
10TH ST

2646 E
10TH ST

2644 E
10TH ST

2642 E
10TH ST

2640 E
10TH ST

2708 E
10TH ST

2820 E
10TH ST

2920 E
10TH ST



0 20 40 80 Feet

Legend

- Poles
- Ⓡ Risers
- ↖ Sidewalk
- V Vaults
- 🏠 Address
- Y Grids
- Conduit
- Y Anchor
- Bloomington_Parcels
- Other Jurisdiction

All Flowerpots 12" DIA



City of Bloomington, IN Permit:
Design View

INI	BY	DATE	DESCRIPTION



3050 E
DISCOVERY
PKWY

E Discovery PKWY

V 30x48x24

71'

678'

54'

E 10th ST

This area to be permitted with INDOT.

N Pete Ellis DR

3210 E
10TH ST

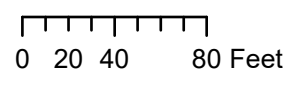

Legend

- Poles
- Risers
- Sidewalk
- V Vaults
- 📍 Address
- Grids
- - - Conduit
- Y Anchor
- Bloomington_Parcels
- - - Other Jurisdiction

All Flowerpots 12" DIA



City of Bloomington, IN Permit:
Design View

INI	BY	DATE	DESCRIPTION



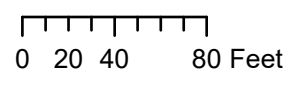
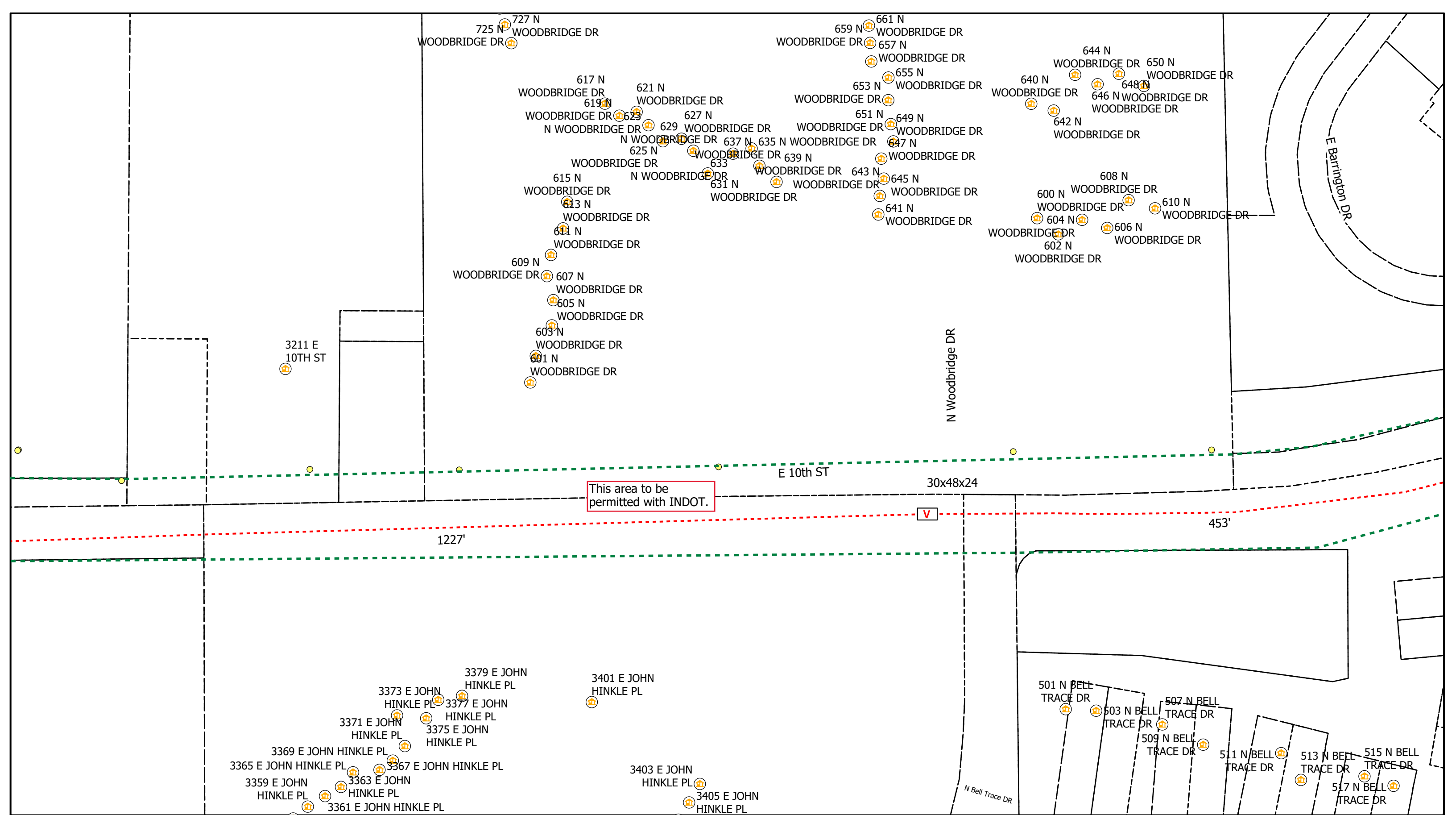

Legend

- Poles
- Risers
- Address
- Conduit
- Y Anchor
- V Vaults
- └ Sidewalk
- Grids
- - - Other Jurisdiction
- Bloomington_Parcels

All Flowerpots 12" DIA



City of Bloomington, IN Permit:
Design View

INI	BY	DATE	DESCRIPTION



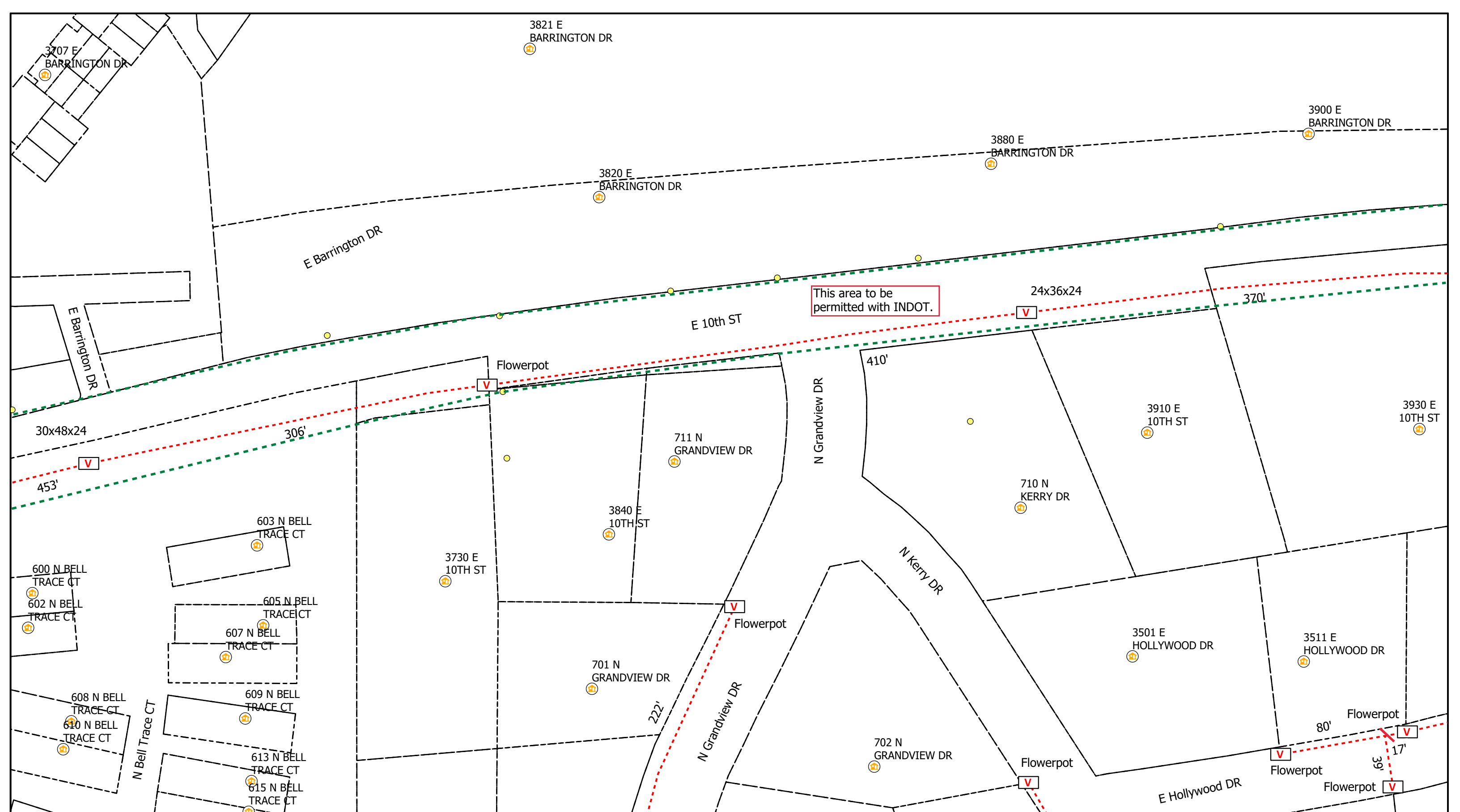

This area to be permitted with INDOT.

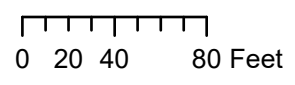

Legend

- Poles
- ⊕ Risers
- ⏏ Sidewalk
- V Vaults
- 🏠 Address
- — — Conduit
- Bloomington_Parcels
- Y Anchor
- Grids
- - - Other Jurisdiction

All Flowerpots 12" DIA



City of Bloomington, IN Permit:
Design View

INI	BY	DATE	DESCRIPTION



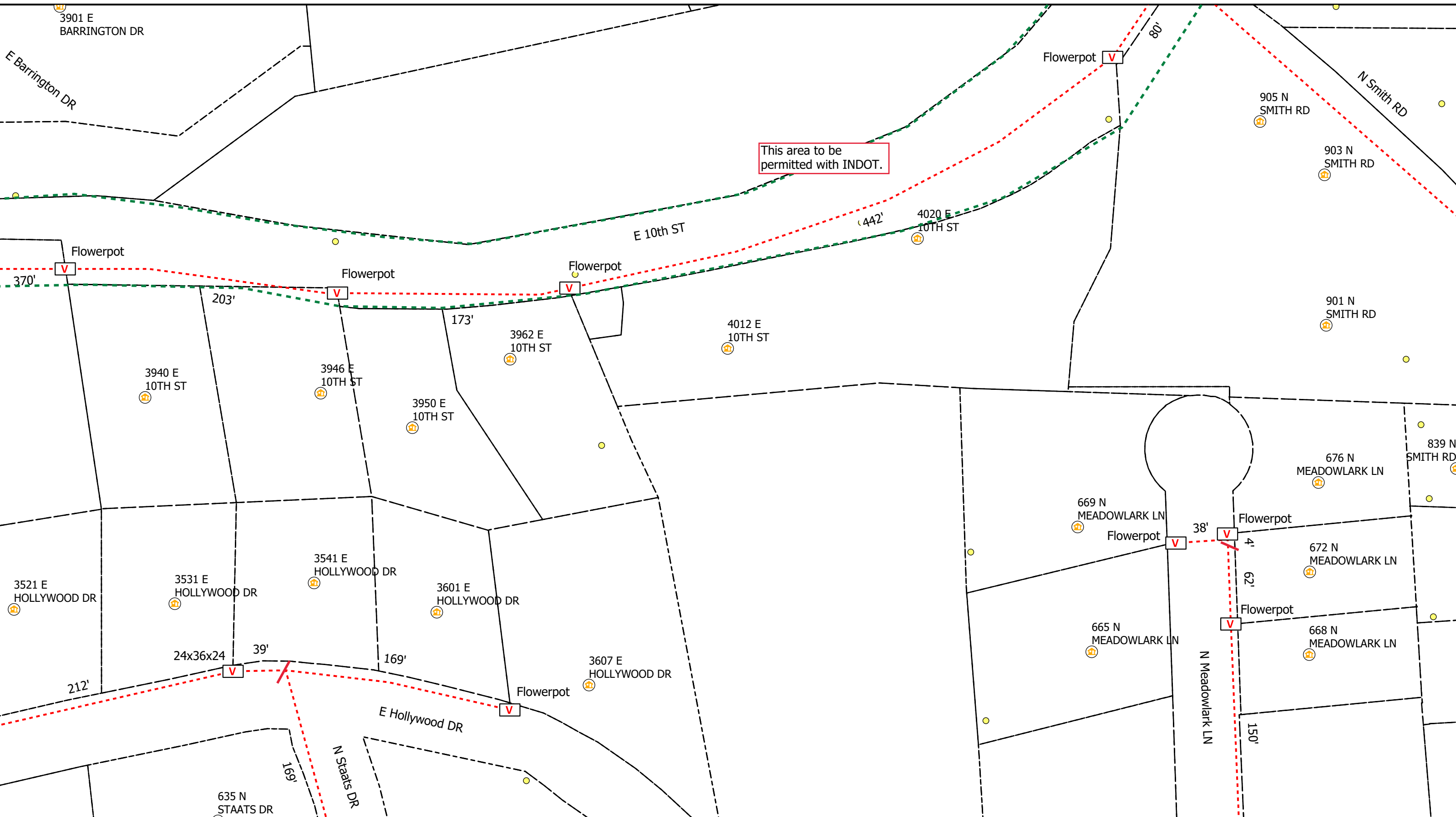

This area to be permitted with INDOT.

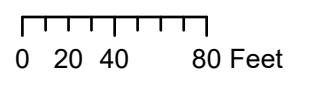

Legend

- Poles
- ⊕ Risers
- ⏏ Sidewalk
- V Vaults
- Ⓜ Address
- Grids
- Conduit
- Y Anchor
- Bloomington_Parcels
- Other Jurisdiction

All Flowerpots 12" DIA



City of Bloomington, IN Permit:
Design View

INI	BY	DATE	DESCRIPTION



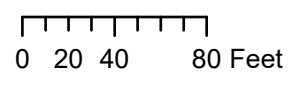
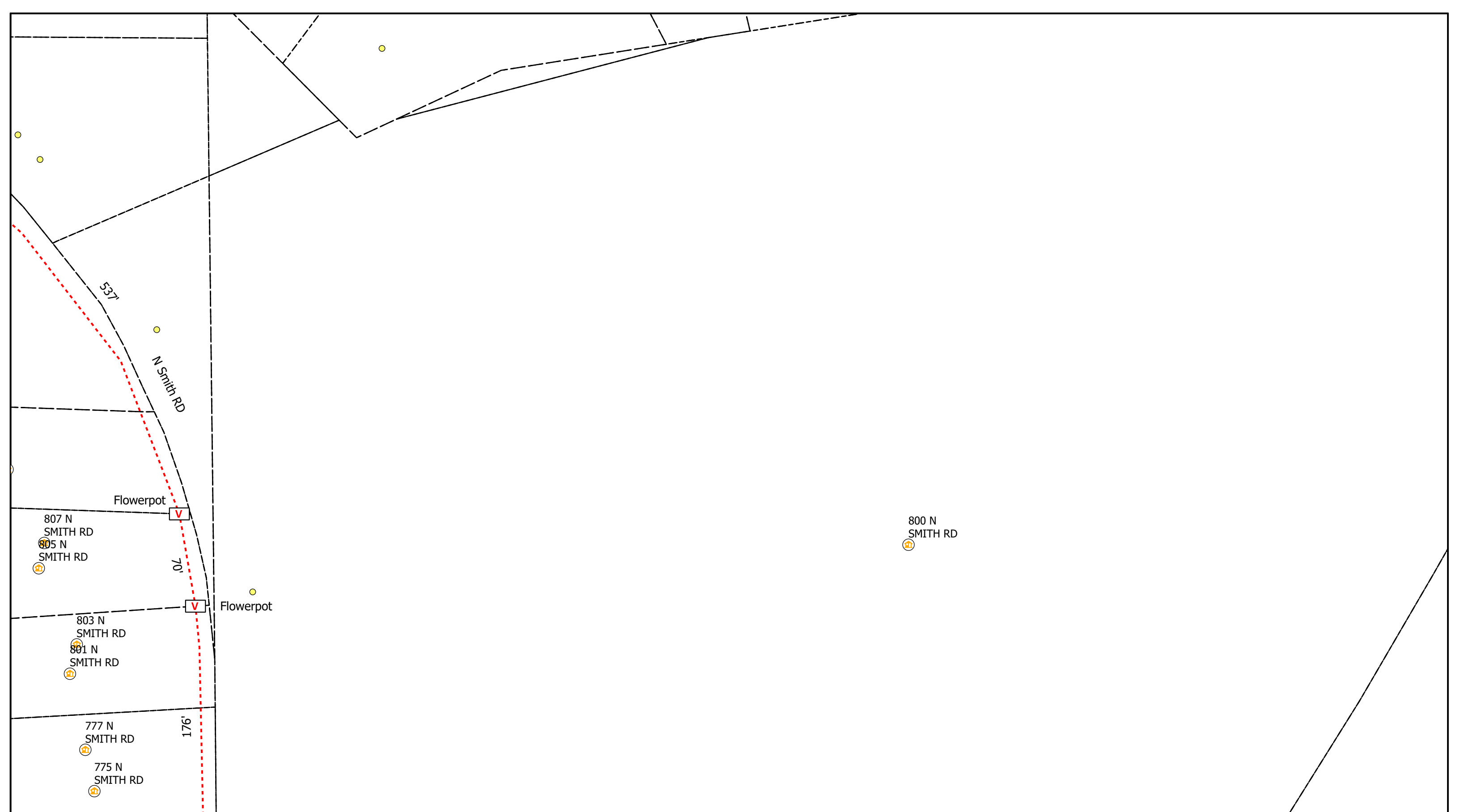

Legend

- Poles
- Ⓡ Risers
- Ⓜ Sidewalk
- V Vaults
- Ⓜ Address
- Grids
- Conduit
- Y Anchor
- Bloomington_Parcels
- Other Jurisdiction

All Flowerpots 12" DIA



City of Bloomington, IN Permit:
Design View

INI	BY	DATE	DESCRIPTION



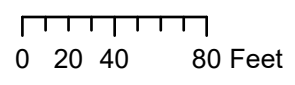
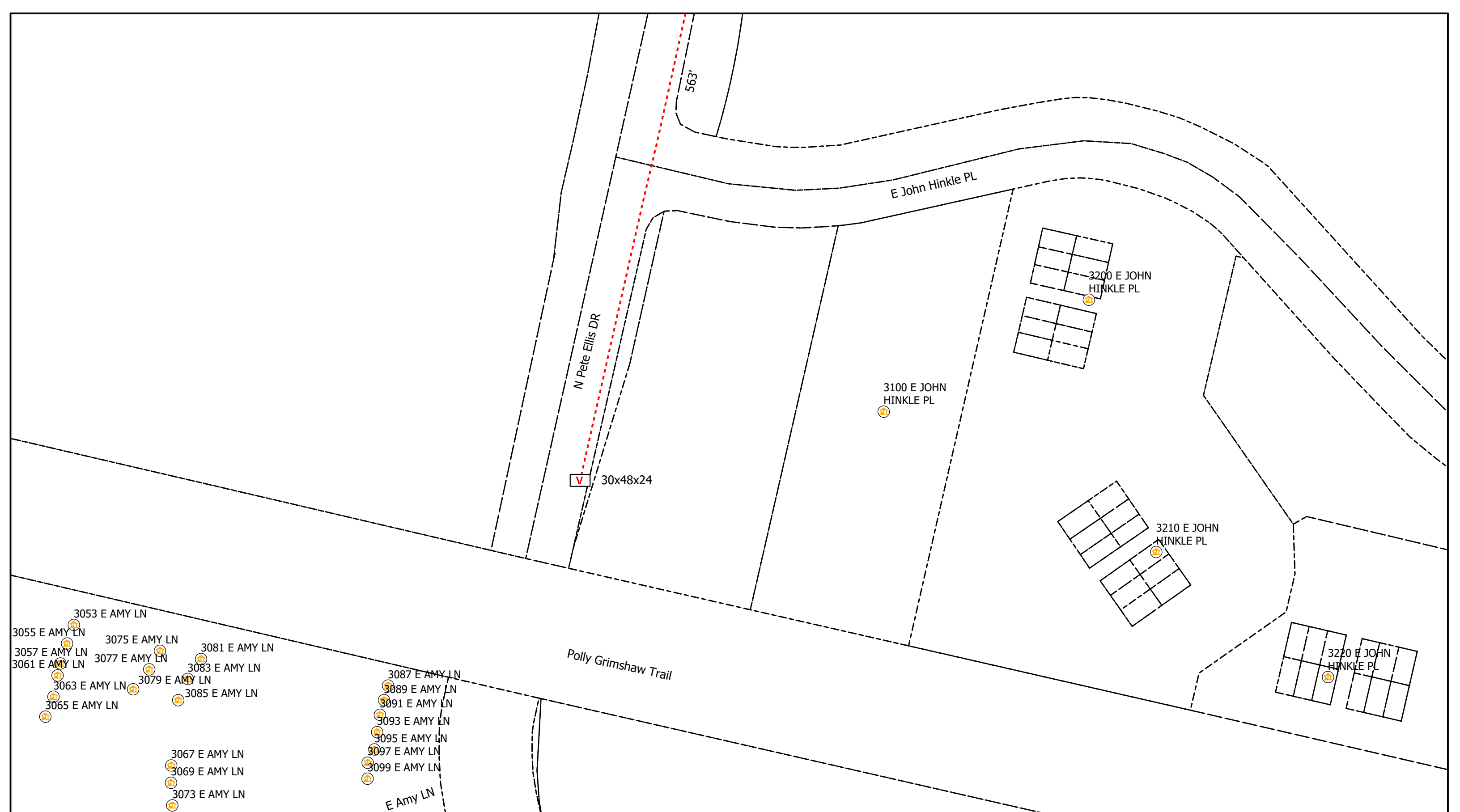

Legend

- Poles
- Risers
- Vaults
- Conduit
- Bloomington_Parcels
- Sidewalk
- Grids
- Other Jurisdiction
- Address
- Anchor

All Flowerpots 12" DIA



City of Bloomington, IN Permit:
Design View

INI	BY	DATE	DESCRIPTION



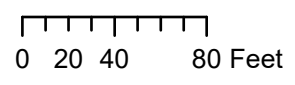
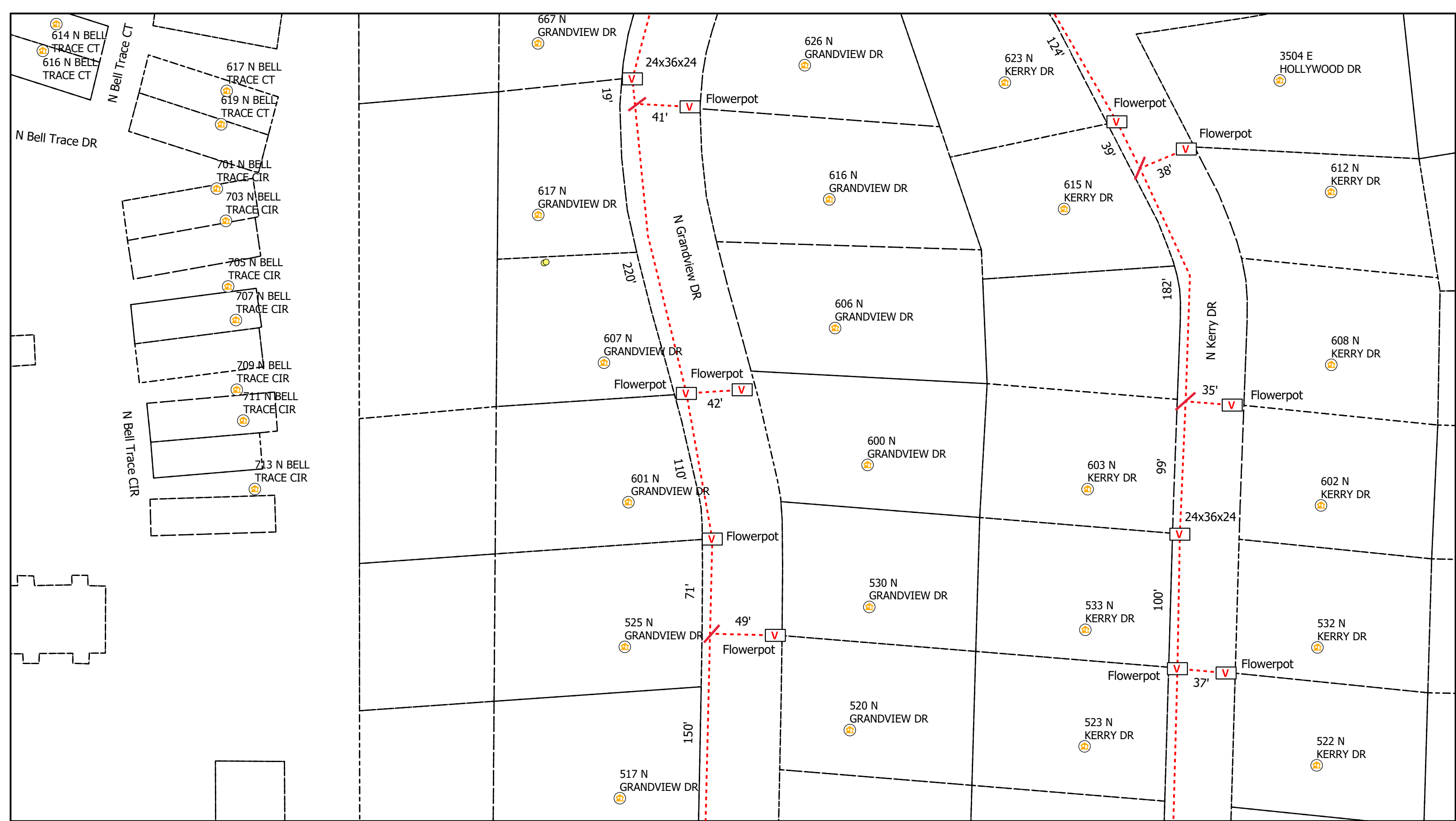

Legend

- Poles
- Risers
- Vaults
- Conduit
- Bloomington_Parcels
- Address
- Anchor
- Sidewalk
- Grids
- Other Jurisdiction

All Flowerpots 12" DIA



City of Bloomington, IN Permit:
Design View

INI	BY	DATE	DESCRIPTION



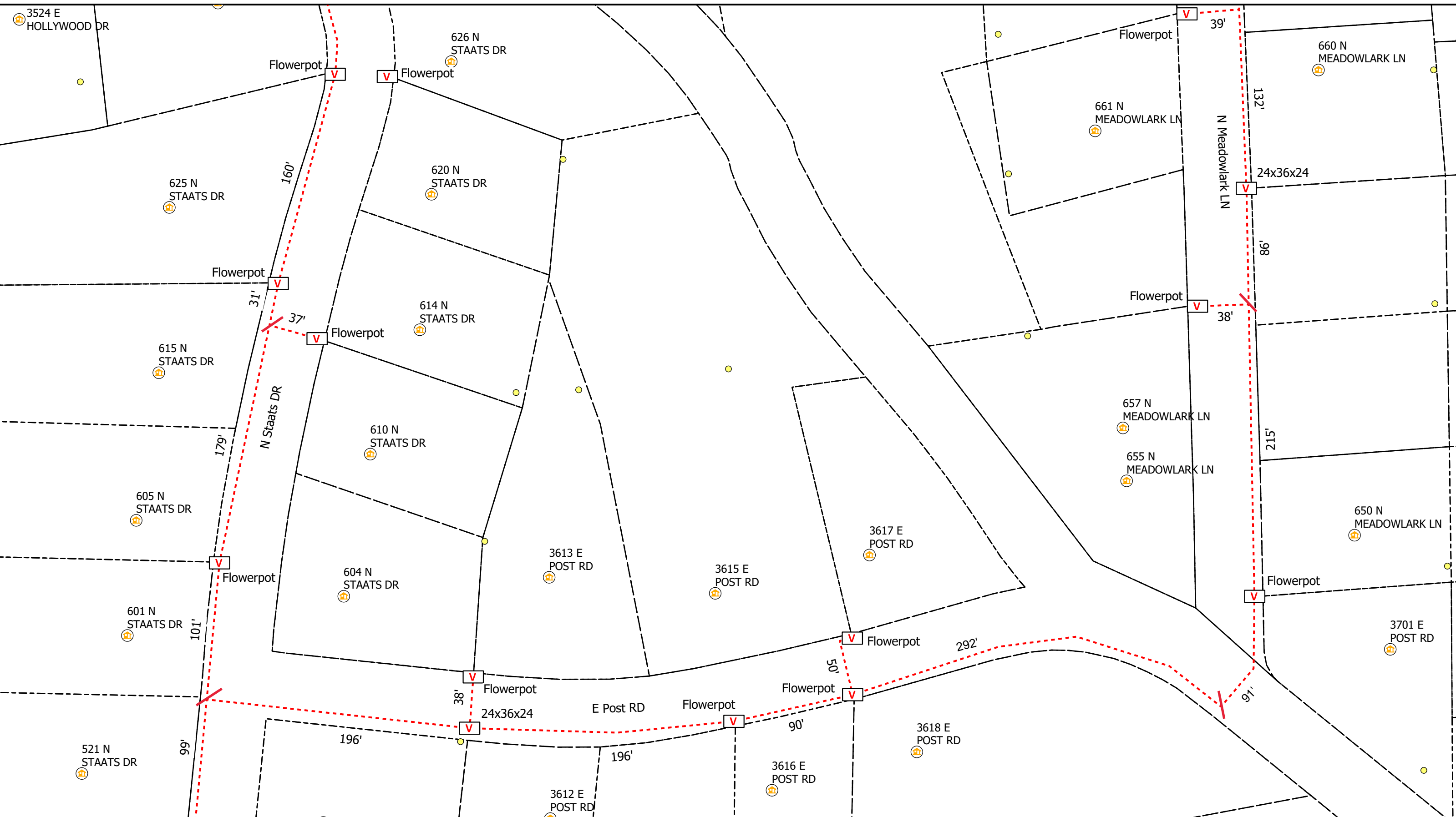

Legend

- Poles
- Risers
- Sidewalk
- Vaults
- Address
- Grids
- Conduit
- Anchor
- Bloomington_Parcels
- Other Jurisdiction

All Flowerpots 12" DIA

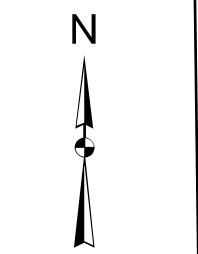

City of Bloomington, IN Permit:
Design View

INI	BY	DATE	DESCRIPTION

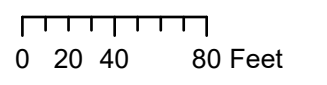
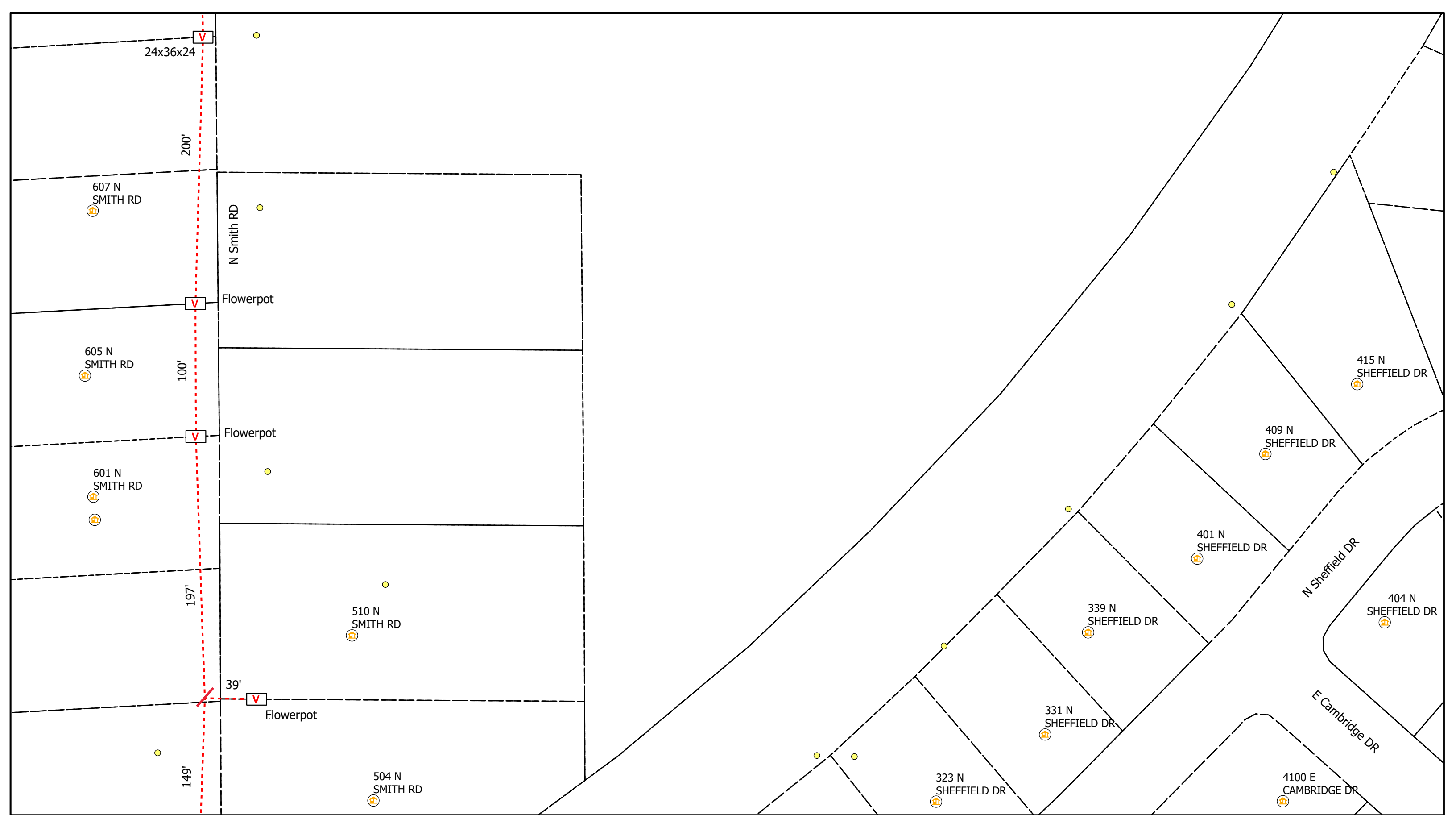

Legend

- Poles
- ⊕ Risers
- ⤴ Sidewalk
- V Vaults
- 🏠 Address
- Grids
- Conduit
- Y Anchor
- Bloomington_Parcels
- Other Jurisdiction

All Flowerpots 12" DIA



City of Bloomington, IN Permit:
Design View

INI	BY	DATE	DESCRIPTION



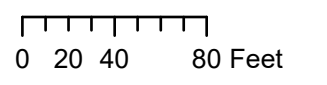
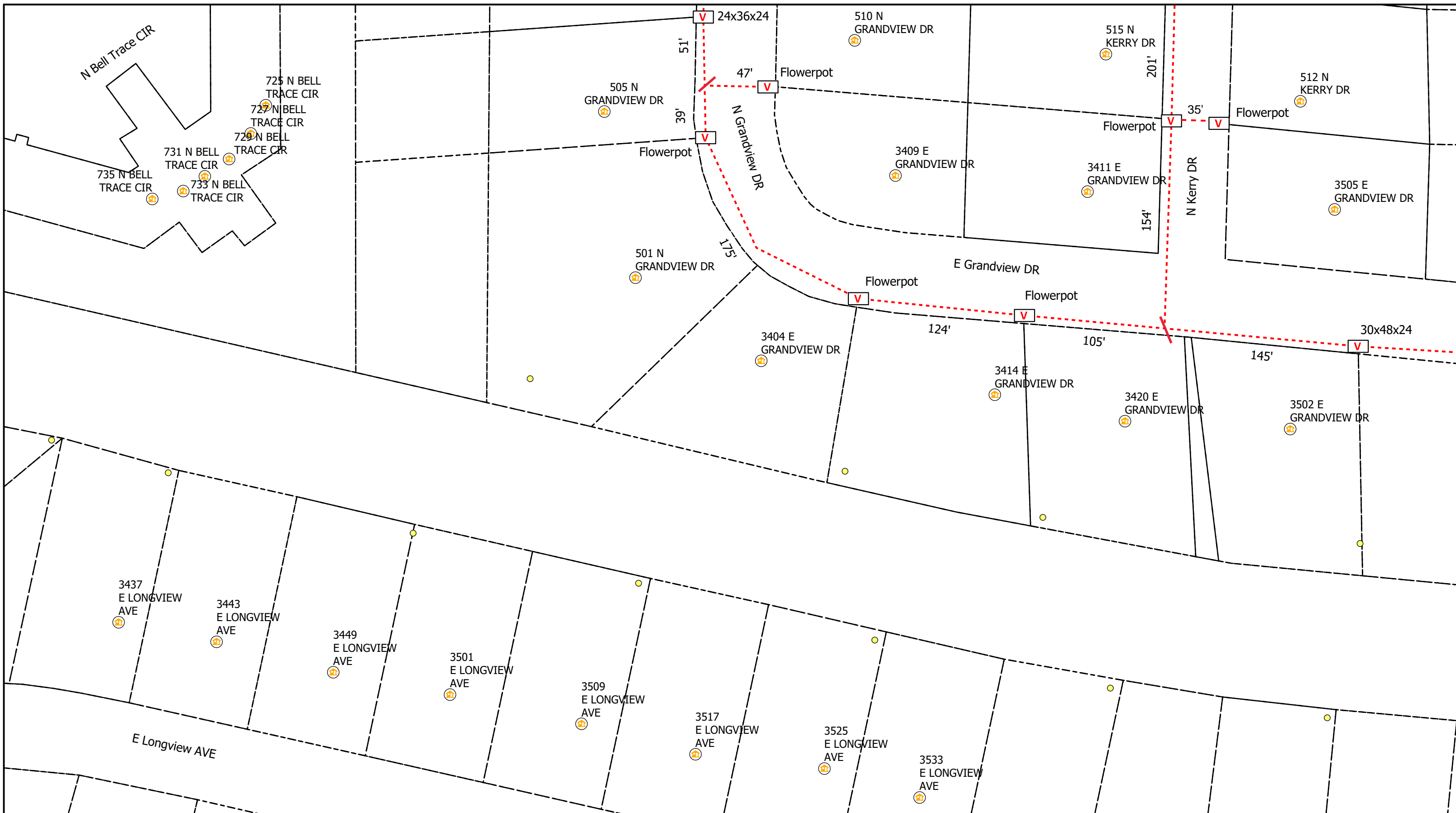

Legend

- Poles
- V Vaults
- Conduit
- Bloomington_Parcels
- R Risers
- H Address
- Y Anchor
- └ Sidewalk
- Grids
- Other Jurisdiction

All Flowerpots 12" DIA



City of Bloomington, IN Permit:
Design View

INI	BY	DATE	DESCRIPTION



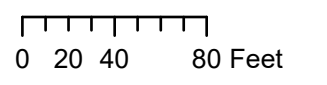
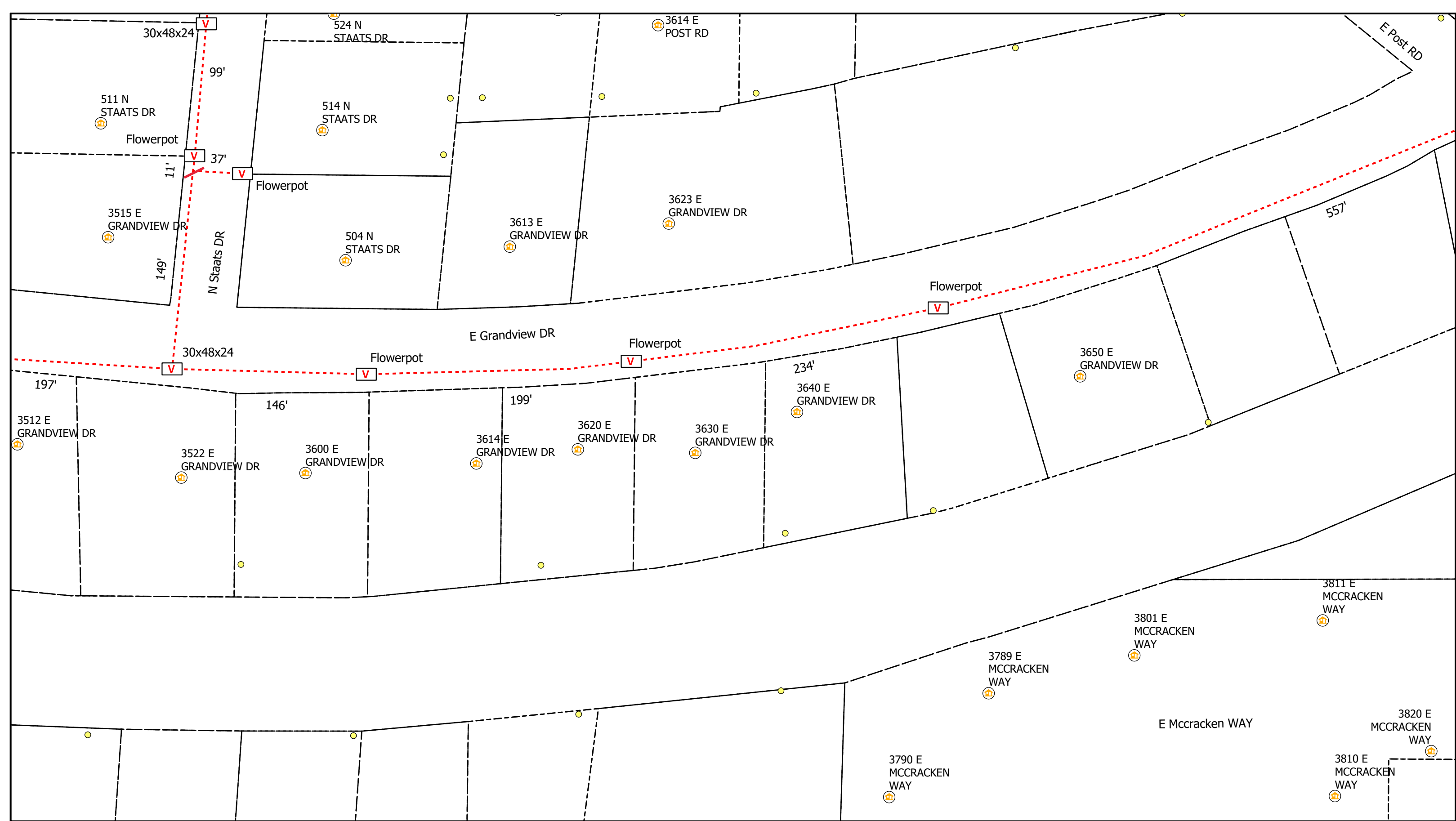

Legend

- Poles
- Ⓡ Risers
- Ⓜ Sidewalk
- V Vaults
- 🏠 Address
- Y Anchor
- Conduit
- Bloomington_Parcels
- Grids
- Other Jurisdiction

All Flowerpots 12" DIA



City of Bloomington, IN Permit:
Design View

INI	BY	DATE	DESCRIPTION



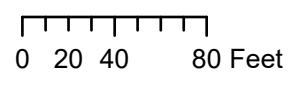
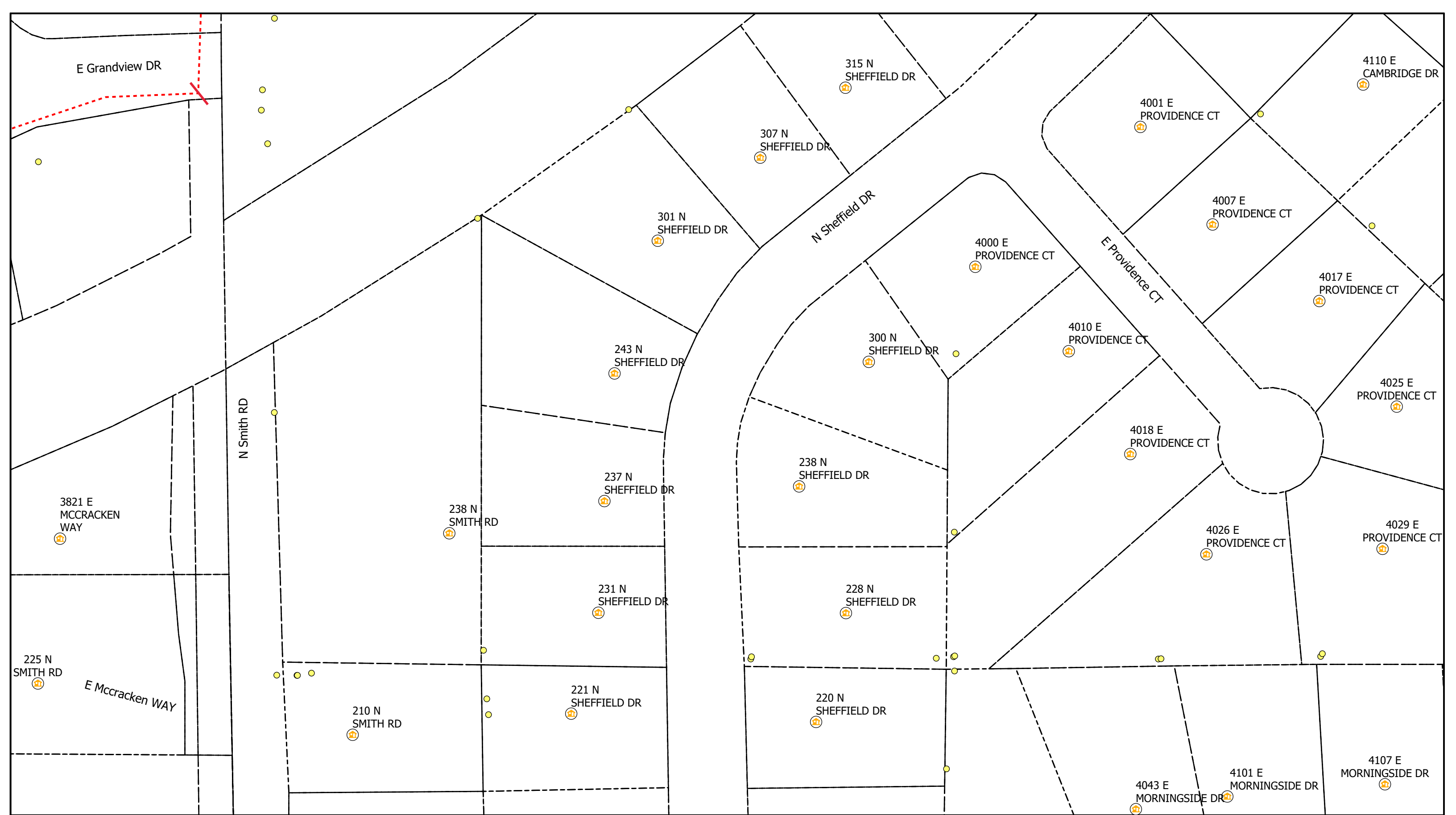

Legend

- Poles
- Ⓡ Risers
- ⏏ Sidewalk
- V Vaults
- 🏠 Address
- Grids
- Conduit
- Y Anchor
- Bloomington_Parcels
- Other Jurisdiction

All Flowerpots 12" DIA



City of Bloomington, IN Permit:
Design View

INI	BY	DATE	DESCRIPTION



CONCEPTUAL SIDE VIEW

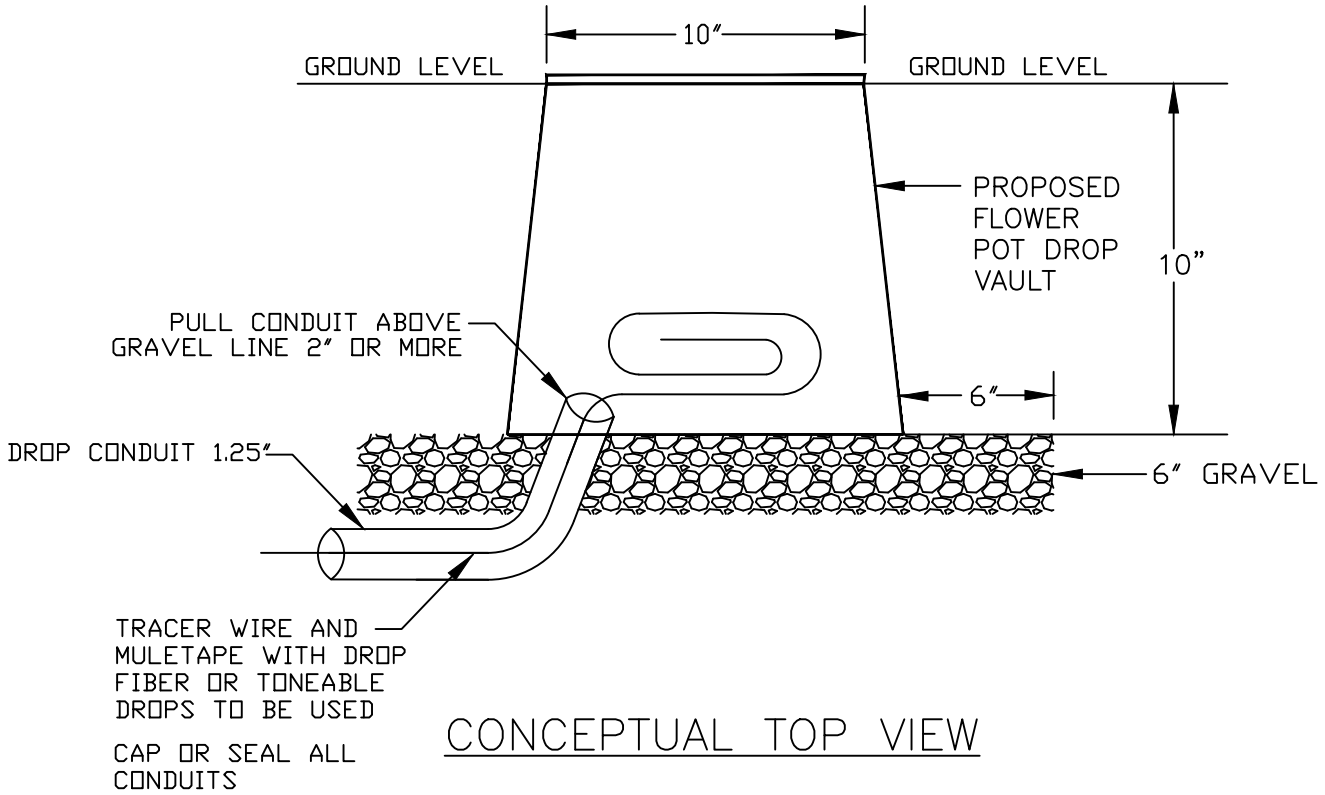

CONCEPTUAL TOP VIEW

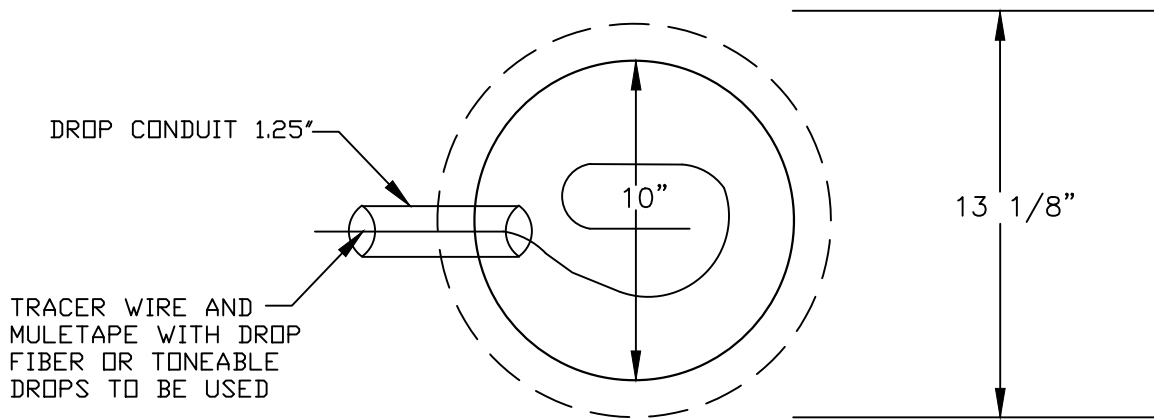

FLOWER POT

30"x48" PC UNIT, 2PC TIER 15/22
 18", 24", and 36" HEIGHT



AMERICAN POLYMER COMPANY

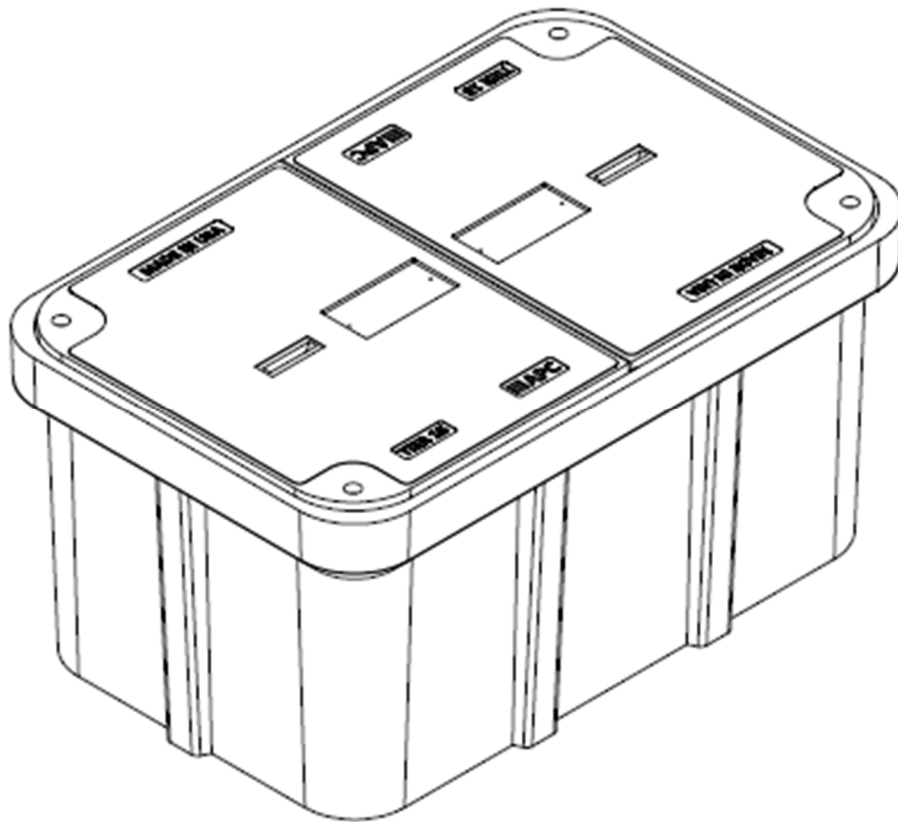

Description	Nominal Size	ANSI Tier	Part Number	Estimated Weight
PC Unit – TIER 15	30"x48"x18"	Tier 15	P304818HU15...	460 lbs.
PC Unit – TIER 22	30"x48"x18"	Tier 22	P304818HU22...	525 lbs.
PC Unit – TIER 15	30"x48"x24"	Tier 15	P304824HU15...	510 lbs.
PC Unit – TIER 22	30"x48"x24"	Tier 22	P304824HU22...	575 lbs.
PC Unit – TIER 15	30"x48"x36"	Tier 15	P304836HU15...	615 lbs.
PC Unit – TIER 22	30"x48"x36"	Tier 22	P304836HU22...	680 lbs.



30"x48" PC UNIT, 2PC TIER 15/22

18", 24", and 36" HEIGHT



AMERICAN POLYMER COMPANY

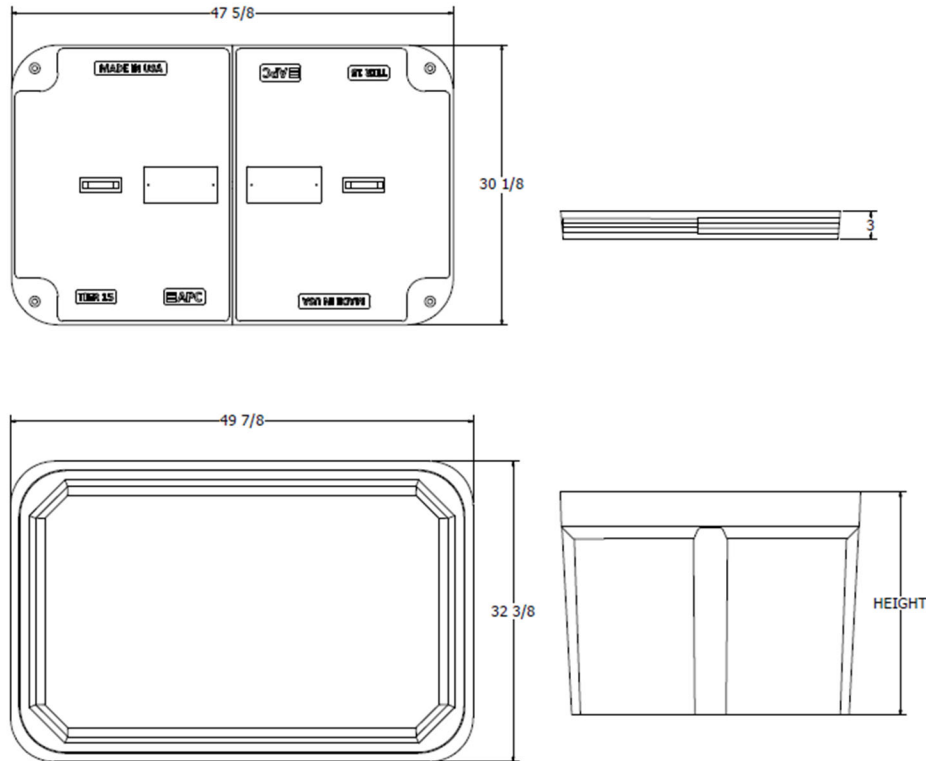

Components	Nominal Size	ANSI Tier	Part Number	Estimated Weight
Replacement Box	30"x48"x18"	Tier 22	P304818B22	185 lbs.
Replacement Box	30"x48"x24"	Tier 22	P304824B22	235 lbs.
Replacement Box	30"x48"x36"	Tier 22	P304836B22	340 lbs.
Replacement Lids - T15	30"x48" (half)	Tier 15	Various	150 lbs.
Replacement Lids - T22	30"x48" (half)	Tier 22	Various	170 lbs.

Bolt options



Machine Thread



Auger Thread



24"x36" PC UNIT, TIER 15/22
 18", 24", 30", and 36" HEIGHT



AMERICAN POLYMER COMPANY

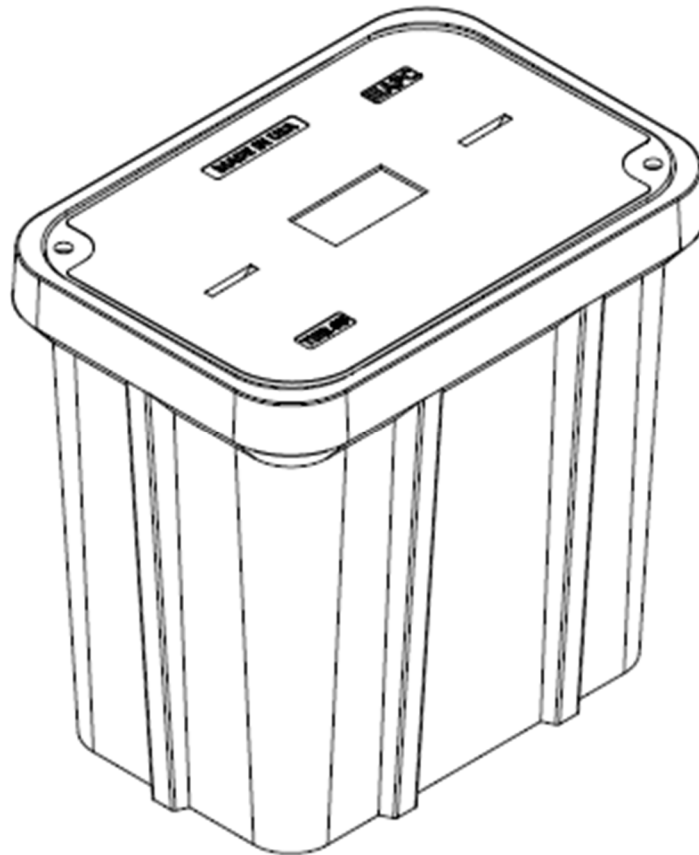

Description	Nominal Size	ANSI Tier	Part Number	Estimated Weight
PC Unit – TIER 15	24x36"x18"	Tier 15	P243618U15...	335 lbs.
PC Unit – TIER 22	24x36"x18"	Tier 22	P243618U22...	355 lbs.
PC Unit – TIER 15	24x36"x24"	Tier 15	P243624U15...	365 lbs.
PC Unit – TIER 22	24x36"x24"	Tier 22	P243624U22...	385 lbs.
PC Unit – TIER 15	24x36"x30"	Tier 15	P243630U15...	395 lbs.
PC Unit – TIER 22	24x36"x30"	Tier 22	P243630U22...	415 lbs.
PC Unit – TIER 15	24x36"x36"	Tier 15	P243636U15...	425 lbs.
PC Unit – TIER 22	24x36"x36"	Tier 22	P243636U22...	445 lbs.



24"x36" PC UNIT, TIER 15/22

18", 24", 30", and 36" HEIGHT



AMERICAN POLYMER COMPANY

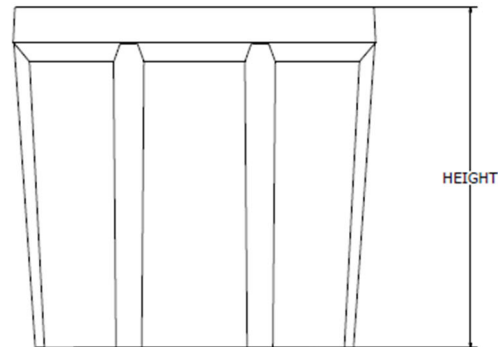
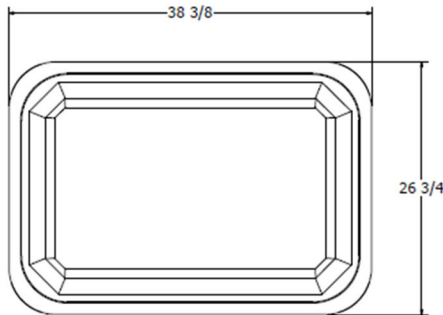
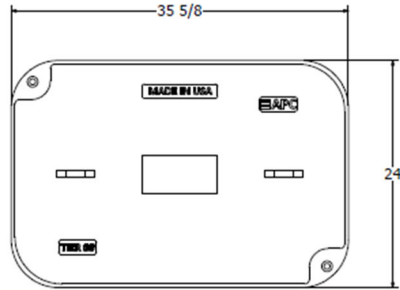

Components	Nominal Size	ANSI Tier	Part Number	Estimated Weight
Replacement Box	24"x36"x18"	Tier 22	P243618B22	165 lbs.
Replacement Box	24"x36"x24"	Tier 22	P243624B22	195 lbs.
Replacement Box	24"x36"x30"	Tier 22	P243630B22	225 lbs.
Replacement Box	24"x36"x36"	Tier 22	P243636B22	255 lbs.
Replacement Lids - T15	24"x36"	Tier 15	Various	170 lbs.
Replacement Lids - T22	24"x36"	Tier 22	Various	190 lbs.

Bolt options

Hex Head



Machine Thread



Penta Head



Auger Thread



17"x30" PC UNIT, TIER 15/22

12", 18", 24", and 30" HEIGHT



AMERICAN POLYMER COMPANY

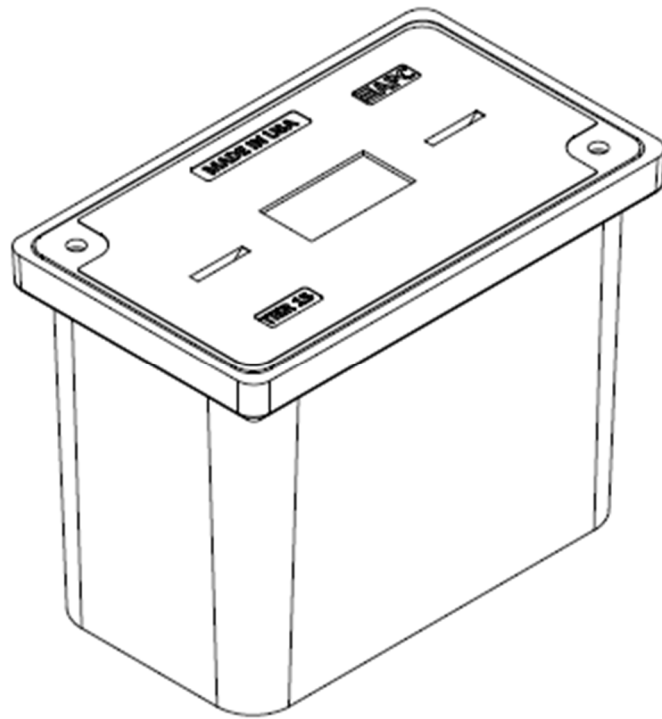

Description	Nominal Size	ANSI Tier	Part Number	Estimated Weight
PC Unit – TIER 15	17"x30"x12"	Tier 15	P173012U15...	138 lbs.
PC Unit – TIER 22	17"x30"x12"	Tier 22	P173012U22...	147 lbs.
PC Unit – TIER 15	17"x30"x18"	Tier 15	P173018U15...	172 lbs.
PC Unit – TIER 22	17"x30"x18"	Tier 22	P173018U22...	181 lbs.
PC Unit – TIER 15	17"x30"x24"	Tier 15	P173024U15...	192 lbs.
PC Unit – TIER 22	17"x30"x24"	Tier 22	P173024U22...	201 lbs.
PC Unit – TIER 15	17"x30"x30"	Tier 15	P173030U15...	217 lbs.
PC Unit – TIER 22	17"x30"x30"	Tier 22	P173030U22...	226 lbs.



17"x30" PC UNIT, TIER 15/22

12", 18", 24", and 30" HEIGHT



AMERICAN POLYMER COMPANY

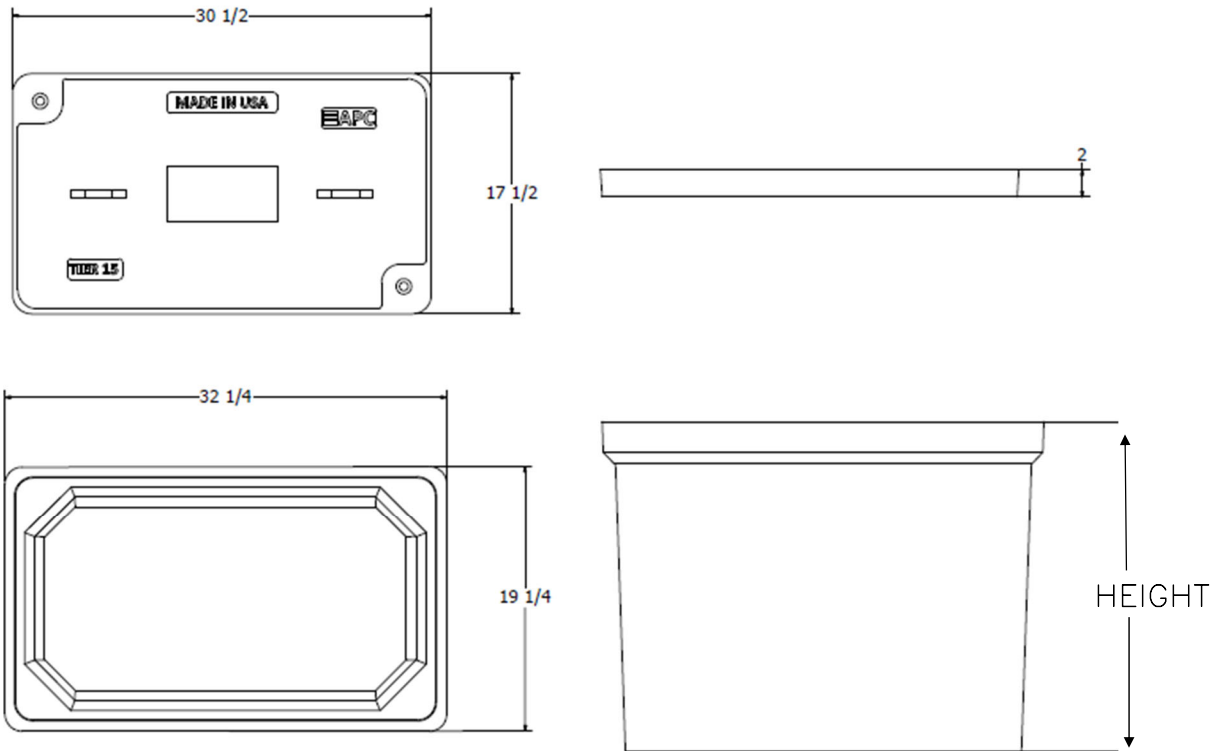

Components	Nominal Size	ANSI Tier	Part Number	Estimated Weight
Replacement Box	17"x30"x12"	Tier 22	P173012B22	66 lbs.
Replacement Box	17"x30"x18"	Tier 22	P173018B22	100 lbs.
Replacement Box	17"x30"x24"	Tier 22	P173024B22	120 lbs.
Replacement Box	17"x30"x30"	Tier 22	P173030B22	145 lbs.
Replacement Lids – T15	17"x30"	Tier 15	Various	72 lbs.
Replacement Lids – T22	17"x30"	Tier 22	Various	81 lbs.

Bolt options



Machine Thread



Auger Thread



33"x60" PC UNIT, 2PC TIER 15/22
36" HEIGHT



AMERICAN POLYMER COMPANY

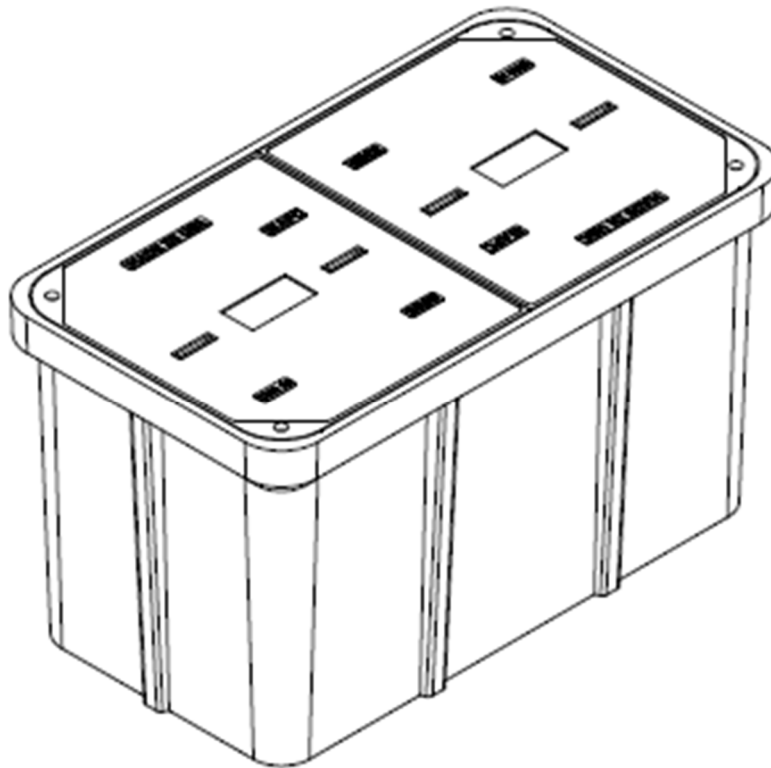

Description	Nominal Size	ANSI Tier	Part Number	Estimated Weight
PC Unit - TIER 15	33"x60"x36"	Tier 15	P336036U15...	930 lbs.
PC Unit - TIER 22	33"x60"x36"	Tier 22	P336036U22...	1030 lbs.



33"x60" PC UNIT, 2PC TIER 15/22

36" HEIGHT



AMERICAN POLYMER COMPANY

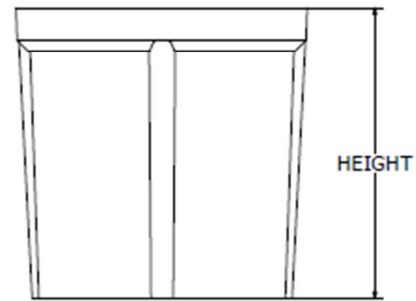
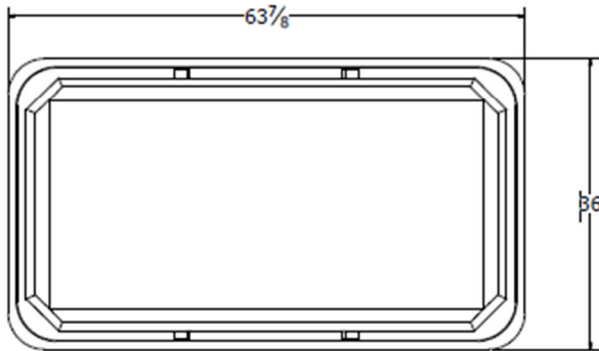
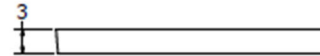
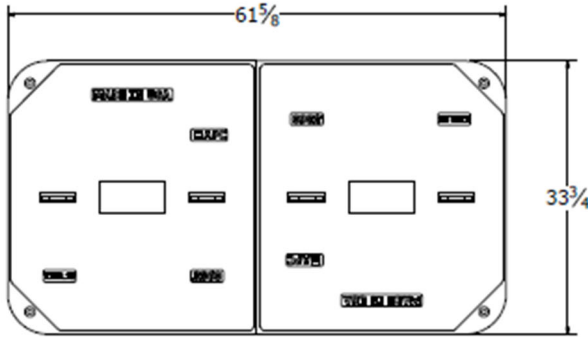

Components	Nominal Size	ANSI Tier	Part Number	Estimated Weight
Replacement Box	33"x60"x36"	Tier 22	P336036B22	530 lbs.
Replacement Lids - T15	33"x60" (half)	Tier 15	Various	200 lbs.
Replacement Lids - T22	33"x60" (half)	Tier 22	Various	250 lbs.

Bolt options

Hex Head



Machine Thread



Penta Head



Auger Thread



Spacing Charts Based on MUTCD			Must be Approved by an Engineer				
Speed (MPH) Prior To Road Work	SIGN SPACING, FT.		BUFFER SPACE, FT.	TAPER LENGTH, FT.		CHANNELIZING SPACING, FT.	
	Non-Divided Highways	Divided Highways	Length	Shoulder (10 ft. Width)	Lane (12 ft. Width)	Through Taper	Through Buffer/Work Area
0-35	200	200	250	70	245	35	50
40-45	350	500	360	150	540	40	80
50-55	500	1000	495	185	660	50	100
60-70	SA-1000, SB-1500, SC-2640		730	235	840	60	120
Urban Low Speed - 100 FT							

APPROVED/ACCEPTED BY:
ENGINEER, OWNER, or PRIME CONTRACTOR
 Check for Notice to Proceed.
BLC01b-F24_E TAMARRON DR - TCP

Signature: _____

Company: _____



Date: 10/6/2022 Project: BLC01b-F24 E TAMARRON DR - TCP :
Traffic Control Suggestion For: AEG :
By: Road Runner Safety Services, Inc. : Nathan

Comments:
Drawing not to scale. Traffic control plan must be approved by an engineer. This is a suggestion only. Road Runners Safety Services, Inc. has no liability for this suggested traffic control plan. Actual placement and spacing of all traffic control devices will depend on field conditions and must conform to MUTCD standards.

- Legend**
- ADA Barricade
 - Channelizer
 - Conduit
 - Flagger (Person)
 - Sign
 - Vault
 - Work Area

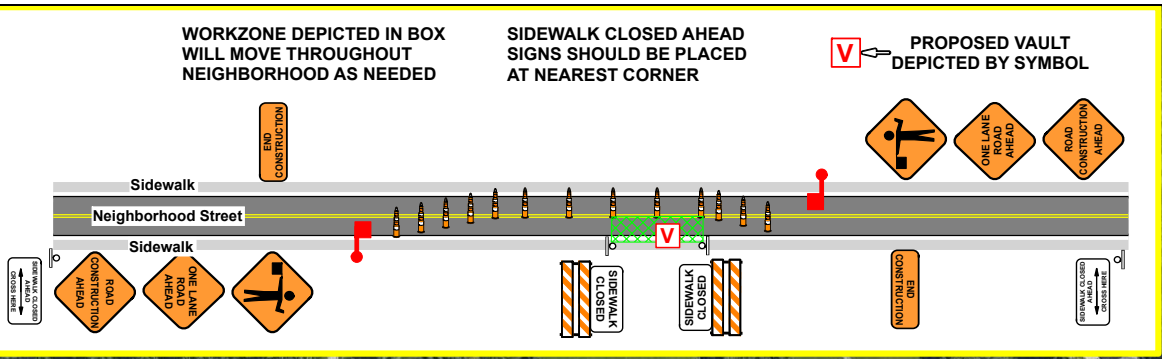
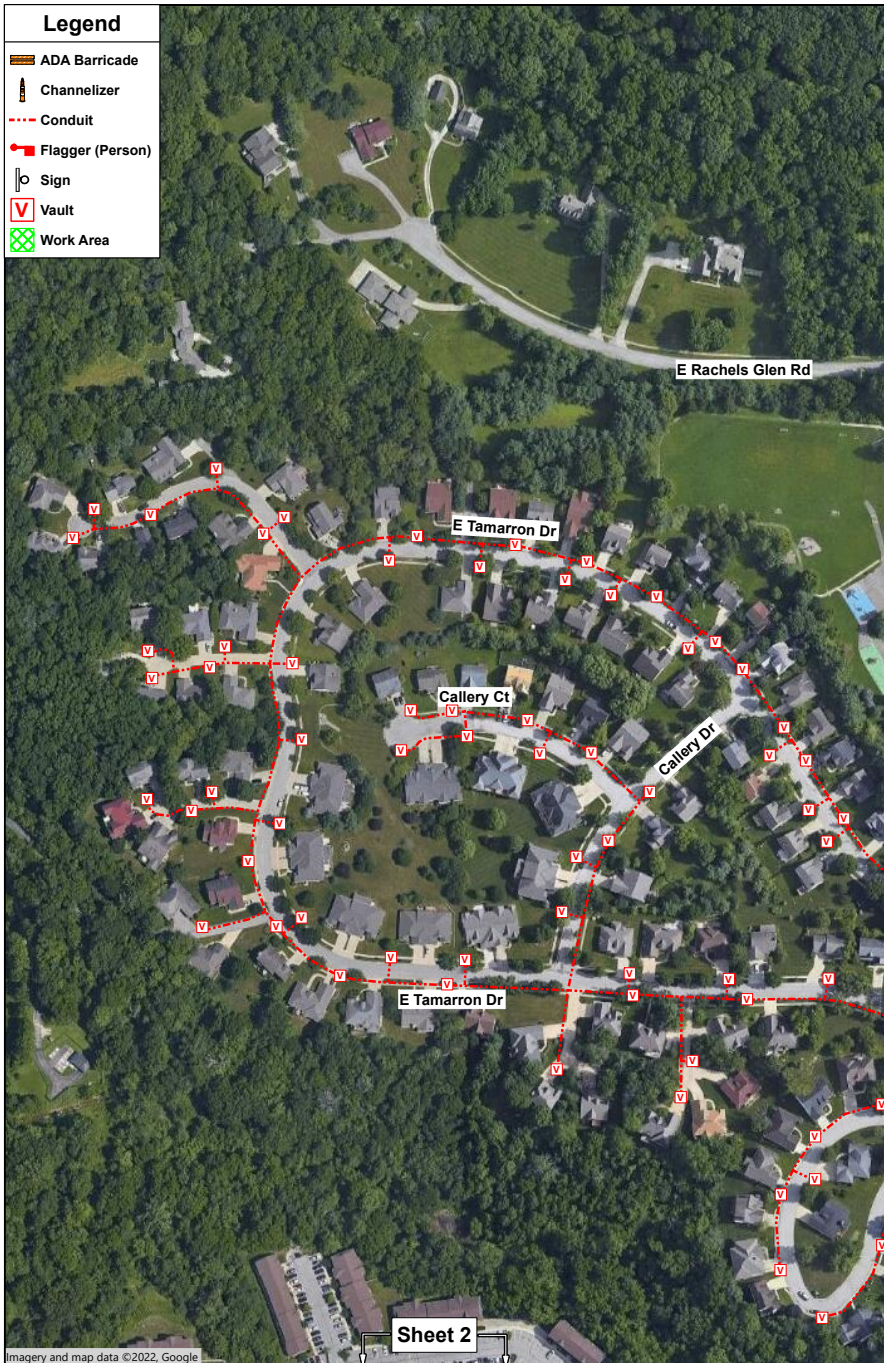

Speed (MPH) Prior To Road Work	SIGN SPACING, FT.		MUTCD Must be Approved by an Engineer				
	Non-Divided Highways	Divided Highways	BUFFER SPACE, FT.	TAPER LENGTH, FT.	CHANNELIZING SPACING, FT.		
	Length	Shoulder (10 ft. Width)	Lane (12 ft. Width)	Through Taper	Through Buffer/Work Area		
0-35	200	200	250	70	245	35	50
40-45	350	500	360	150	540	40	80
50-55	500	1000	495	185	660	50	100
60-70	SA-1000, SB-1500, SC-2640 Urban Low Speed - 100 FT		730	235	840	60	120

APPROVED/ACCEPTED BY:
ENGINEER, OWNER, or PRIME CONTRACTOR
 Check for Notice to Proceed.
BLC01b-F24_E TAMARRON DR - TCP

Signature: _____

Company: _____

Date: 10/6/2022 **Project:** BLC01b-F24 E TAMARRON DR - TCP :
: **Traffic Control Suggestion For:** AEG :
By: Road Runner Safety Services, Inc. : Nathan

Comments:
Drawing not to scale. Traffic control plan must be approved by an engineer. This is a suggestion only. Road Runners Safety Services, Inc. has no liability for this suggested traffic control plan. Actual placement and spacing of all traffic control devices will depend on field conditions and must conform to MUTCD standards.

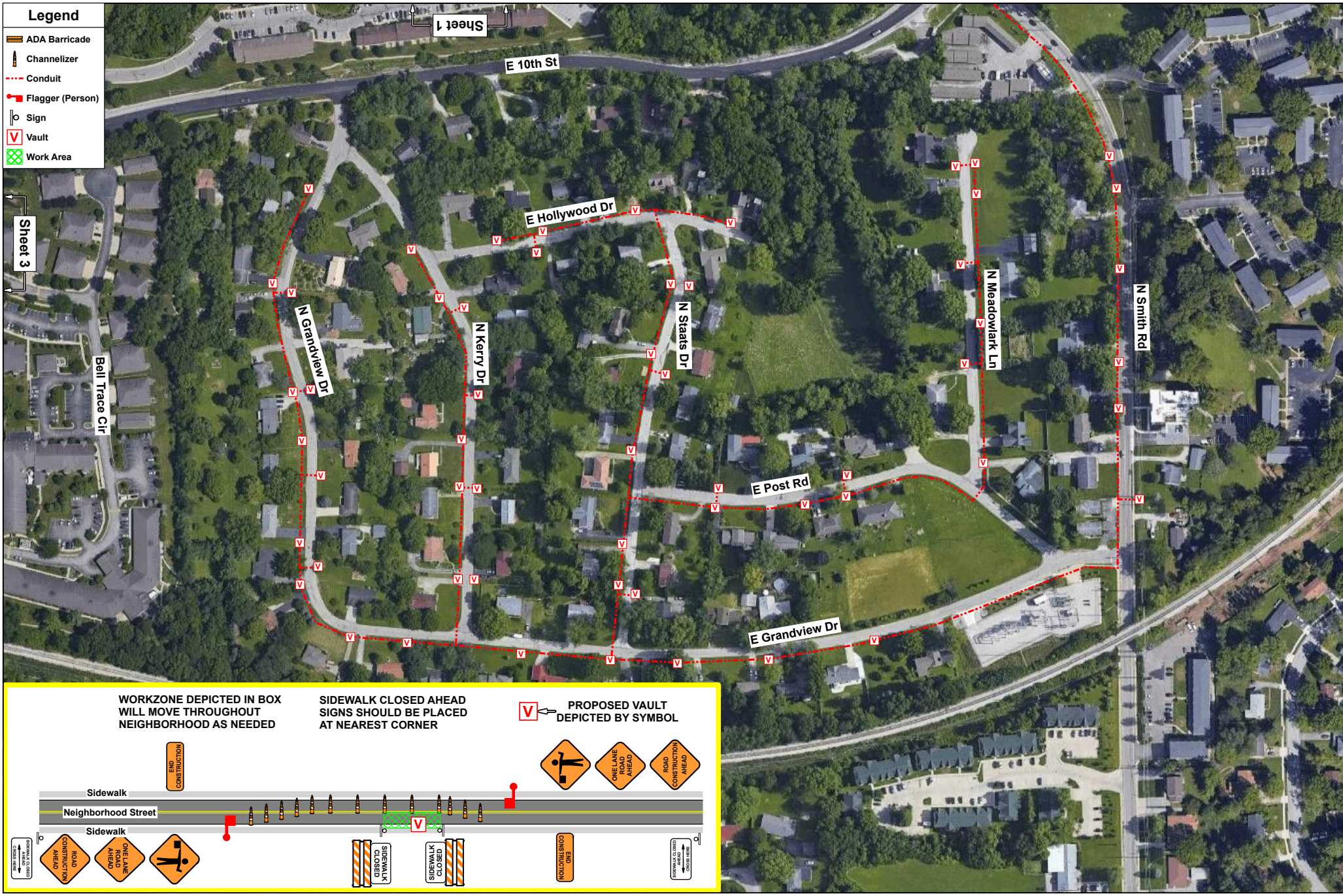

- Legend**
- ADA Barricade
 - Channelizer
 - Conduit
 - Flagger (Person)
 - Sign
 - Vault
 - Work Area

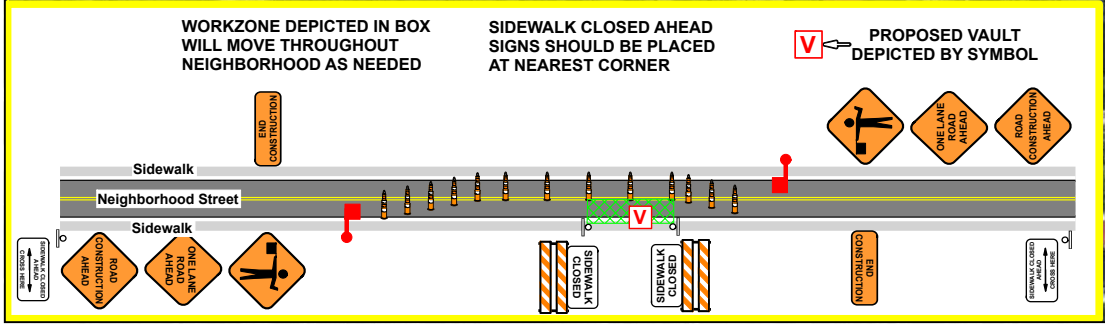

Spacing Charts Based on MUTCD			Must be Approved by an Engineer				
Speed (MPH) Prior To Road Work	SIGN SPACING, FT.		BUFFER SPACE, FT.	TAPER LENGTH, FT.		CHANNELIZING SPACING, FT.	
	Non-Divided Highways	Divided Highways	Length	Shoulder (10 ft. Wide)	Lane (12 ft. Wide)	Through Taper	Through Buffer/Work Area
0-35	200	200	250	70	245	35	50
40-45	350	500	360	150	540	40	80
50-55	500	1000	495	185	660	50	100
60-70	SA-1000, SB-1500, SC-2640		730	235	840	60	120
Urban Low Speed - 100 FT							

APPROVED/ACCEPTED BY:
ENGINEER, OWNER, or PRIME CONTRACTOR
 Check for Notice to Proceed.
BLC01b-F24_E TAMARRON DR - TCP

Signature: _____

Company: _____

Date: 10/6/2022 **Project:** BLC01b-F24_E TAMARRON DR - TCP :
Traffic Control Suggestion For: AEG :
By: Road Runner Safety Services, Inc. : Nathan

Comments:
Drawing not to scale. Traffic control plan must be approved by an engineer. This is a suggestion only. Road Runners Safety Services, Inc. has no liability for this suggested traffic control plan. Actual placement and spacing of all traffic control devices will depend on field conditions and must conform to MUTCD standards.



- Legend**
- ADA Barricade
 - Channelizer
 - Conduit
 - Flagger (Person)
 - Sign
 - Vault
 - Work Area

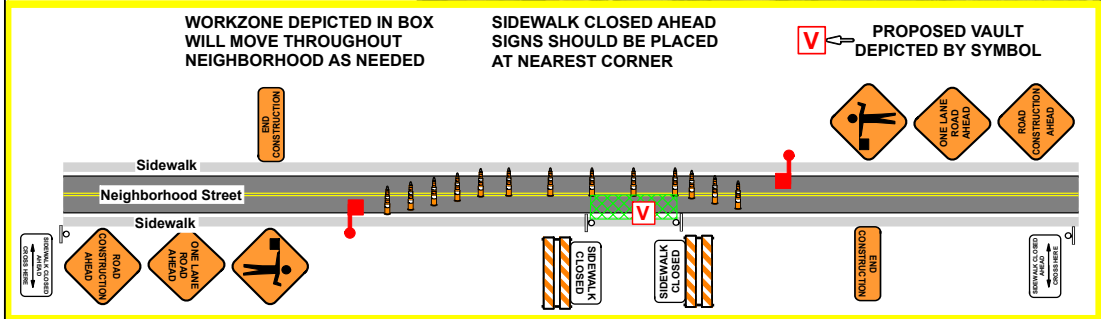

Sheet 2



CITY OF BLOOMINGTON RIGHT-OF-WAY USE PERMIT APPLICATION

401 N Morton Street, Suite 130
P.O. Box 100
Bloomington, IN 47402

Phone: (812) 349-3913
Fax: (812) 349-3520
Email:
engineering@bloomington.in.gov

ROW EXCAVATION ROW USE

ADDRESS OF ROW ACTIVITY: E Janet Dr

A. APPLICANT/AGENT INFORMATION:		D. TRAFFIC CONTROL DEVICES*:	
APPLICANT NAME: <u>Bret Simons</u>		<input checked="" type="checkbox"/> CONES <input type="checkbox"/> ARROWBOARD	
E-MAIL: <u>bret.simons@aeg.cc</u>		<input type="checkbox"/> LIGHTED BARRELS <input checked="" type="checkbox"/> TYPE 3 BARRICADES	
COMPANY: <u>Atlantic Engineering Group</u>		<input checked="" type="checkbox"/> FLAGGERS <input type="checkbox"/> BPD OFFICER	
ADDRESS: <u>P.O. Box 349</u>		*PROVIDING MUTCD COMPLIANT TEMPORARY TRAFFIC CONTROL DEVICES AND MAINTENANCE OF TRAFFIC (MOT) PLAN IS YOUR RESPONSIBILITY AND REQUIRED. See page 3 for additional MOT resources; the graph paper can be used for your MOT site plan if needed or you can submit a separate sheet	
CITY, STATE, ZIP: <u>Buford, GA 30515</u>			
24-HR EMERGENCY CONTACT NAME: <u>(706)654-2298</u>		E. METERED PARKING SPACES NEEDED: <input type="checkbox"/> Y <input type="checkbox"/> N	
24-HR CONTACT PHONE #: _____		IT IS THE RESPONSIBILITY OF THE APPLICANT TO RESERVE PARKING METER(S) APPLICATION LOCATED: https://bloomington.in.gov/transportation/parking/moving OR CONTACT PARKING SERVICES WITH QUESTIONS AT (812)349-3436	
INSURANCE #*: <u>883724951</u> COMPANY: <u>ACORD</u>		F. IS THIS A <input type="checkbox"/> CBU* <input type="checkbox"/> COUNTY* <input type="checkbox"/> IU* <input type="checkbox"/> NP* PROJECT?	
BOND #*: <u>1160465</u> COMPANY: <u>LEXON</u>		PROJECT NAME: <u>BLC01b-F16 E Janet Dr</u>	
*INSURANCE & BOND MUST BE ON FILE WITH THE CITY BEFORE PERMIT WILL BE ISSUED		PROJECT #: <u>BLC01b-F16 E Janet Dr</u>	
SUBCONTRACTOR INFORMATION		PROJECT MGR.: <u>Lex Mullins</u>	
(LIST ALL COMPANIES WORKING UNDER PRIMARY CONTRACTOR PERMIT)		PROJECT MGR. #: <u>215-847-8819</u>	
COMPANY NAME: _____		*CBU = CITY OF BLOOMINGTON UTILITIES *COUNTY = MONROE COUNTY	
B. WORK DESCRIPTION:		*IU = INDIANA UNIVERSITY *NP = NOT-FOR-PROFIT AGENCY	
<input type="checkbox"/> POD/DUMPSTER <input type="checkbox"/> CRANE <input type="checkbox"/> SCAFFOLDING <input checked="" type="checkbox"/> CONSTRUCTION USE*		G. EXCAVATIONS:	
(EXPLAIN): <u>Excavation</u>		SQ FT OF PAVEMENT* EXCAVATIONS : <u>N/A</u>	
*EXCAVATION, LONG TERM USE FOR STORAGE OF MATERIAL/EQUIPMENT/WALKAROUND		*PAVEMENT INCLUDES: IN OR UNDER CONCRETE, OR ASPHALT INCLUDING CURBS	
C. RIGHT OF WAY TO BE USED/CLOSED:		SQ FT OF NON-PAVEMENT* EXCAVATIONS: <u>417 Sq Ft</u>	
STREET NAME 1: <u>E Janet Dr</u>		*DIRT, GRASS, GRAVEL, LANDSCAPE AREA OR OTHER UNPAVED SURFACE	
1ST INTERSECTING STREET NAME: _____		LINEAL FT OF BORE*: <u>16,254 Lineal Ft</u>	
2ND INTERSECTING STREET NAME: _____		*BORE PITS SHALL BE CALCULATED AS SQ FT EXCAVATIONS	
<input type="checkbox"/> ROAD CLOSURE <input checked="" type="checkbox"/> LANE CLOSURE 1 <input checked="" type="checkbox"/> 2 <input type="checkbox"/> 3 <input type="checkbox"/>		# OF POLE INSTALLATIONS/REMOVAL: <u>N/A</u>	
<input checked="" type="checkbox"/> SIDEWALK* <input type="checkbox"/> BIKE LANE <input type="checkbox"/> OTHER		SQ FT OF SIDEWALK RECONSTRUCTION*: <u>N/A</u>	
TRANSIT STOP? <input type="checkbox"/> Y <input type="checkbox"/> N PARKING LANE(S)** <input type="checkbox"/> Y <input type="checkbox"/> N **NON-METERED		*CONCRETE OR ASPHALT SIDEWALK/PATH BEING IMPROVED/REPLACED	
START DATE: <u>Oct 28th</u> END DATE: _____ # OF DAYS*: <u>30</u>		SQ FT OF SIDEWALK NEW CONSTRUCTION*: <u>N/A</u>	
STREET NAME 2: _____		*CONCRETE OR ASPHALT SIDEWALK/PATH THAT IS NEW INFRASTRUCTURE	
1ST INTERSECTING STREET NAME: _____		#RESIDENTIAL DRIVEWAY INSTALLATION: <u>N/A</u>	
2ND INTERSECTING STREET NAME: _____		 <p>TO SUBMIT A LOCATE REQUEST 24 HRS A DAY, 7 DAYS A WEEK CALL 811 OR 800-382-5544 CALL 2 WORKING DAYS BEFORE YOU DIG. IT'S THE LAW.</p>	
<input type="checkbox"/> ROAD CLOSURE <input type="checkbox"/> LANE CLOSURE 1 <input type="checkbox"/> 2 <input type="checkbox"/> 3 <input type="checkbox"/>			
<input type="checkbox"/> SIDEWALK* <input type="checkbox"/> BIKE LANE <input type="checkbox"/> OTHER		H. INDEMNIFICATION AGREEMENT:	
TRANSIT STOP? <input type="checkbox"/> Y <input type="checkbox"/> N PARKING LANE(S)** <input type="checkbox"/> Y <input type="checkbox"/> N **NON-METERED		The petitioner/applicant hereby agrees to hold harmless, defend and to indemnify the City of Bloomington from or against all claims, action, damages and expenses, including but not limited to reasonable attorney's fees or any alleged injury and/or death to any person or damage to any property arising, or alleged to have arisen out of any act of commission or omission on the part of the petitioner/applicant, his/her heirs, successors, or assigns regardless of whether such acts are the direct or indirect result of the public right-of-way use pursuant to this permit grant.	
START DATE: _____ END DATE: _____ # OF DAYS*: _____		I AFFIRM, UNDER THE PENALTIES FOR PERJURY, THAT THE FOREGOING REPRESENTATIONS ARE TRUE.	
*SIDEWALK CLOSURES FOR A PERIOD OR PERIODS TOTALING 24HRS OR MORE SHALL INSTALL A WALKAROUND UNLESS OTHERWISE APPROVED DURING REVIEW		PRINT NAME: <u>Bret Simons</u>	
STANDARD CLOSURE HOURS MON-FRI*: 9:00 AM - 3:00 PM & 6:00 PM - 9:00 PM		SIGNATURE: <u>Bret Simons</u>	
STANDARD CLOSURE HOURS <input checked="" type="checkbox"/> *NON-STANDARD CLOSURE HOURS <input type="checkbox"/>		DATE: <u>10/14/2022</u>	
REQUESTED CLOSURE HOURS: _____ AM - _____ PM			
*non-standard hours may not be allowed near schools, on arterials, or other circumstances and are subject to approval during the permitting process			
BMC 14.09.040 allows work from 6 AM to 10 PM without violating the noise ordinance (7AM to 9PM for pneumatic hammers)			

For Administration Use Only (applicable to CLOSURE approval)

Approved By: _____ BPW City Engineer Director Date: _____

Staff Representative: _____ Phone#: _____ Date: _____

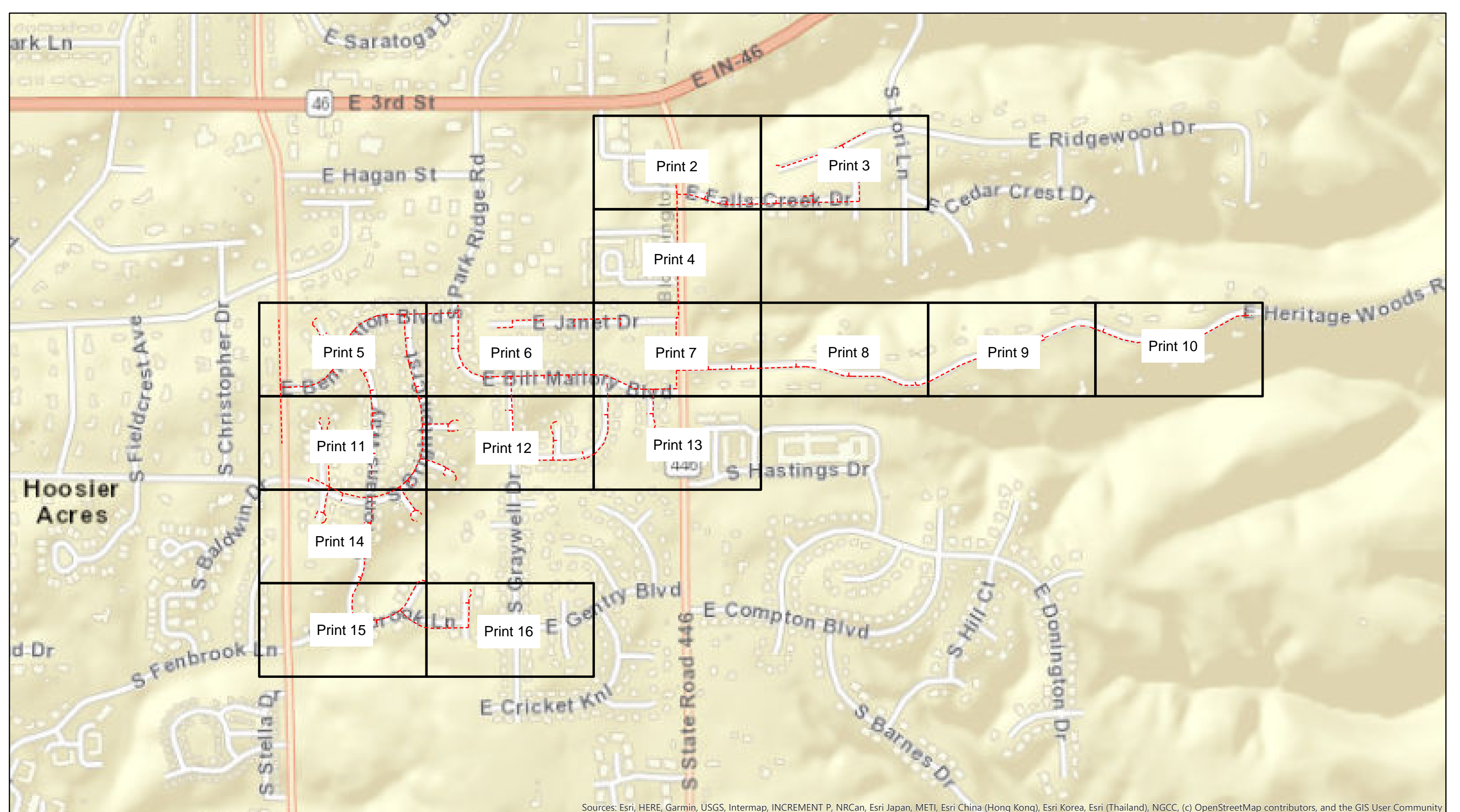

Sources: Esri, HERE, Garmin, USGS, Intermap, INCREMENT P, NRCAN, Esri Japan, METI, Esri China (Hong Kong), Esri Korea, Esri (Thailand), NGCC, (c) OpenStreetMap contributors, and the GIS User Community



Legend BLC01b-F16 - E Janet Dr

- - - Conduit
- Grids



City of Bloomington, IN Permit:
Design View

INI	BY	DATE	DESCRIPTION

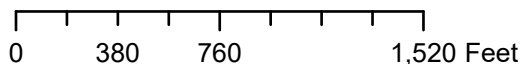

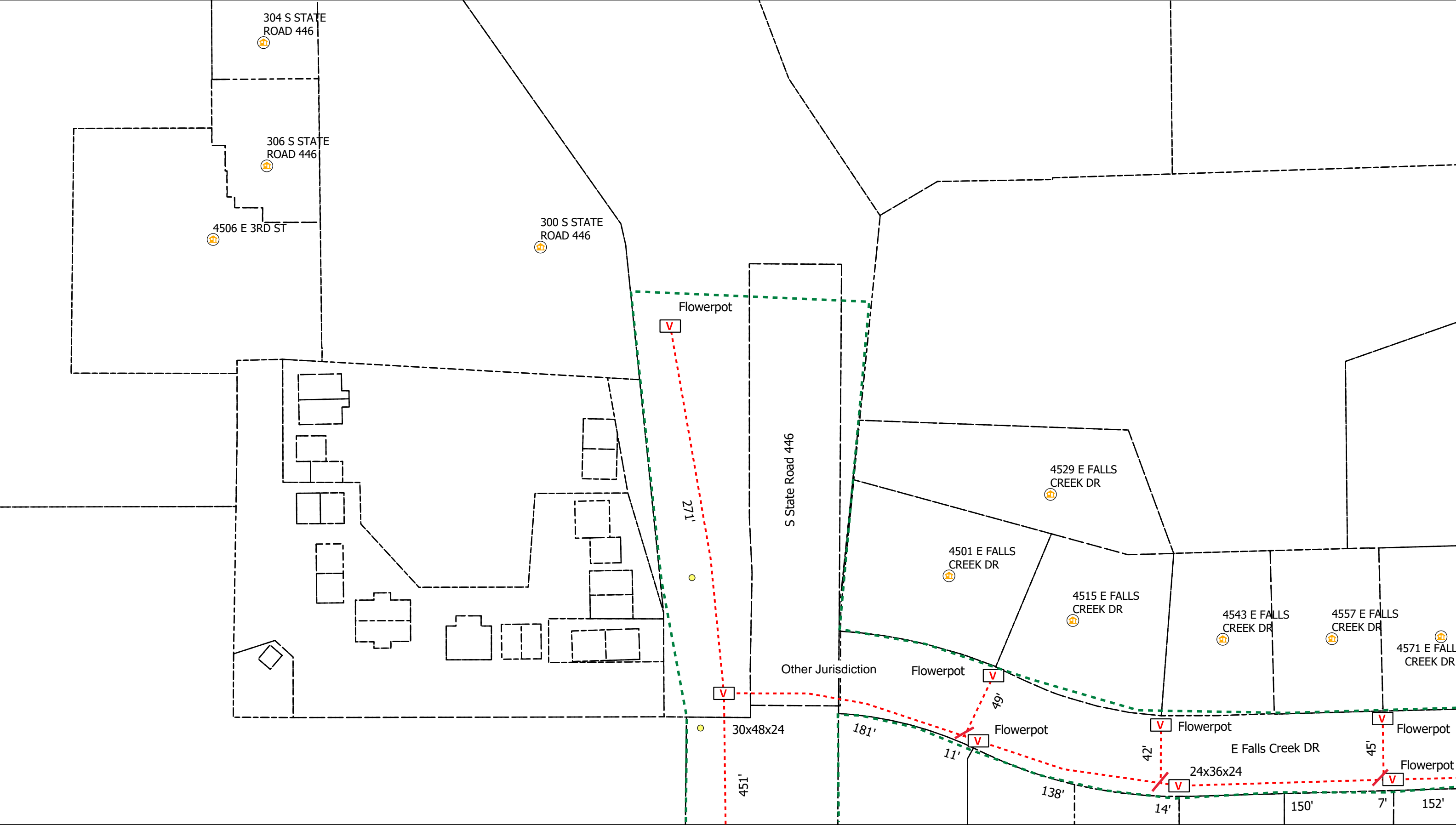

Legend

- Poles
- V Vaults
- Overhead Strand
- Conduit
- Bloomington_Parcels
- R Risers
- 🏠 Address
- Other Jurisdiction
- Y Anchor
- ← Sidewalk
- Grids

All Flowerpots 12" DIA



City of Bloomington, IN Permit:
Design View

INI	BY	DATE	DESCRIPTION



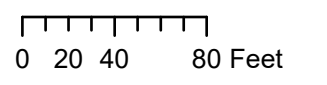
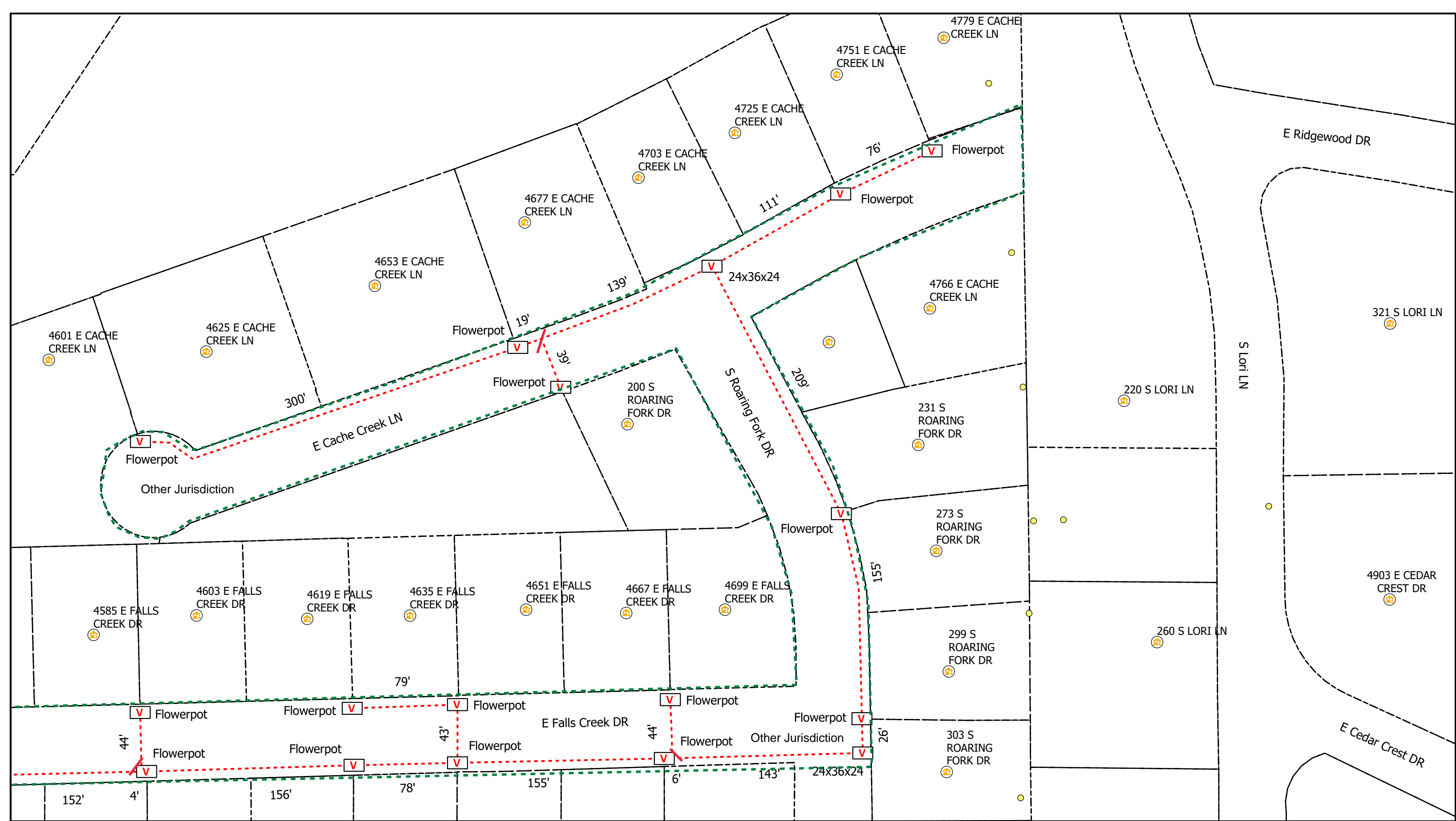

Legend

- Poles
- V Vaults
- Overhead Strand
- Conduit
- Bloomington_Parcels
- R Risers
- Ⓜ Address
- Other Jurisdiction
- Y Anchor
- ← Sidewalk
- Grids

All Flowerpots 12" DIA



City of Bloomington, IN Permit:
Design View

INI	BY	DATE	DESCRIPTION



4500 E FALLS CREEK DR
 4514 E FALLS CREEK DR
 4528 E FALLS CREEK DR
 4556 E FALLS CREEK DR
 4570 E FALLS CREEK DR

S State Road 446

451'
 Other Jurisdiction

V

30x48x24

612 S STATE ROAD 446

345'

597 S STATE ROAD 446

4499 E JANET DR

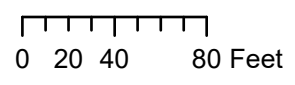

Legend

- Poles
- V Vaults
- Overhead Strand
- - - Conduit
- Bloomington_Parcels
- Ⓡ Risers
- Ⓧ Address
- - - Other Jurisdiction
- Y Anchor
- ← Sidewalk
- Grids

All Flowerpots 12" DIA



City of Bloomington, IN Permit:
 Design View

INI	BY	DATE	DESCRIPTION



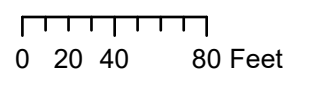
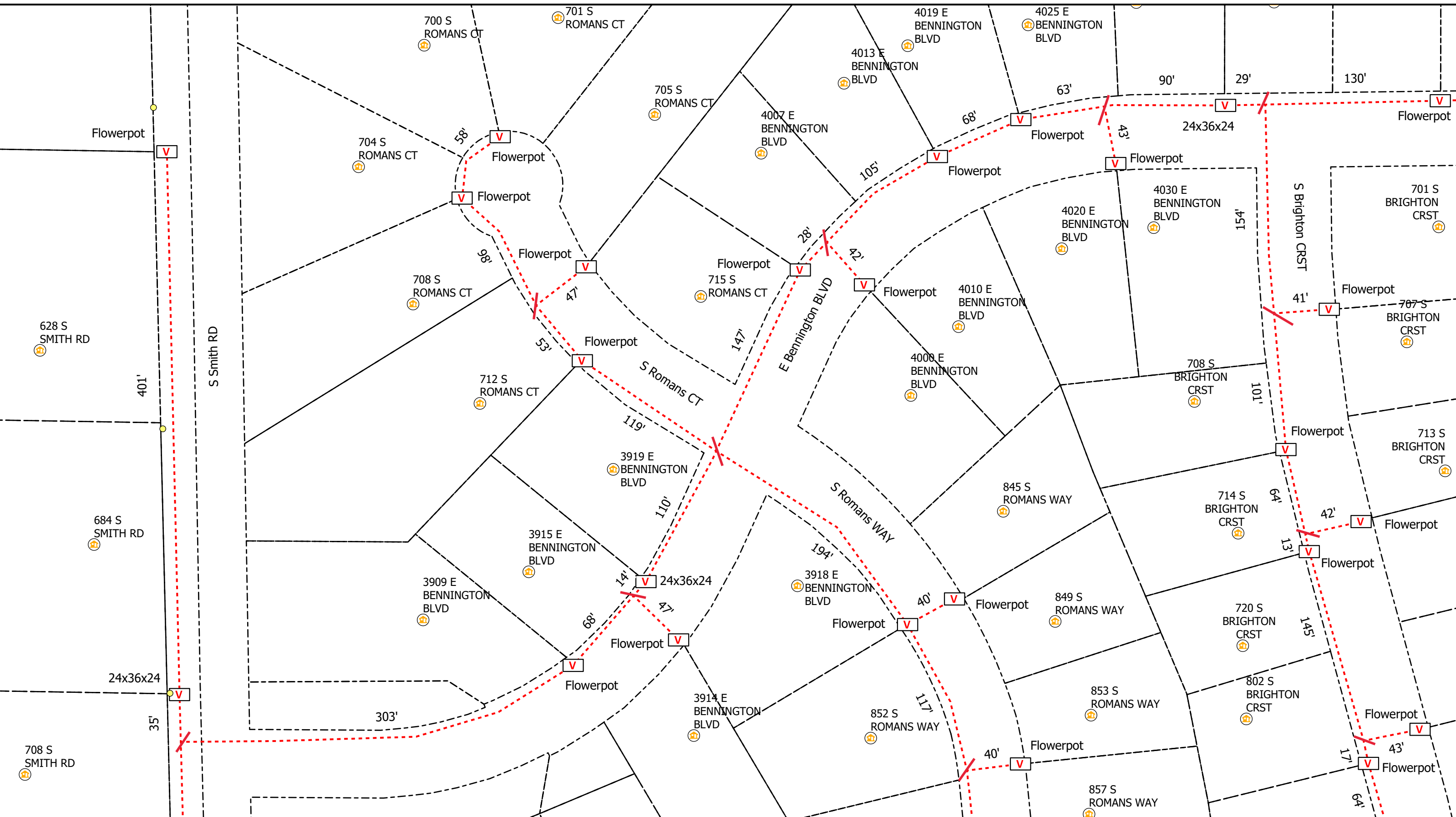

Legend

- Poles
- V Vaults
- Overhead Strand
- Conduit
- Bloomington_Parcels
- R Risers
- Ⓜ Address
- Other Jurisdiction
- Y Anchor
- ← Sidewalk
- Grids

All Flowerpots 12" DIA



City of Bloomington, IN Permit:
Design View

INI	BY	DATE	DESCRIPTION



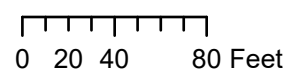
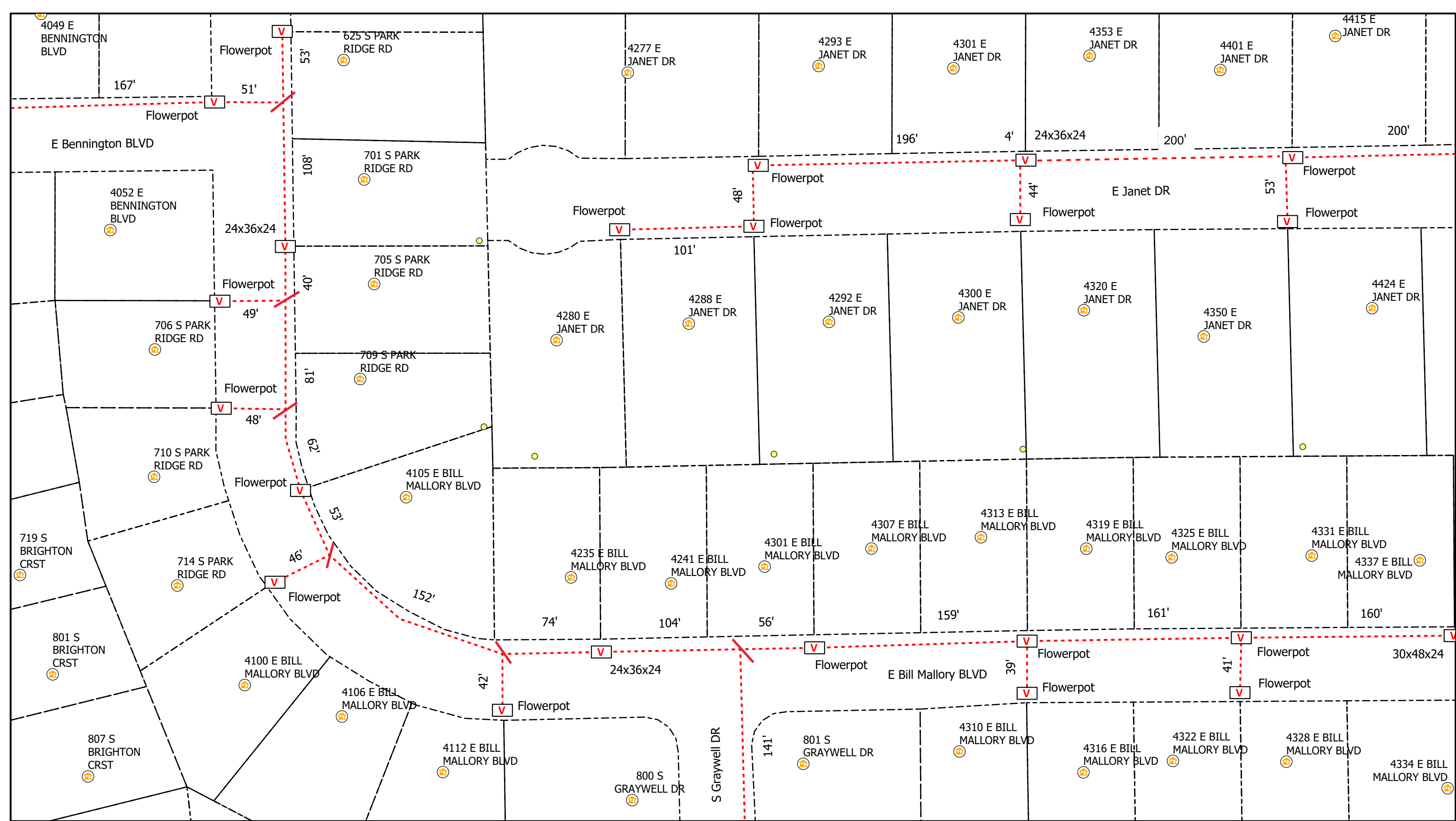

Legend

- Poles
- Vaults
- Overhead Strand
- Conduit
- Bloomington_Parcels
- Risers
- Address
- Other Jurisdiction
- Anchor
- Sidewalk
- Grids

All Flowerpots 12" DIA



City of Bloomington, IN Permit:
Design View

INI	BY	DATE	DESCRIPTION



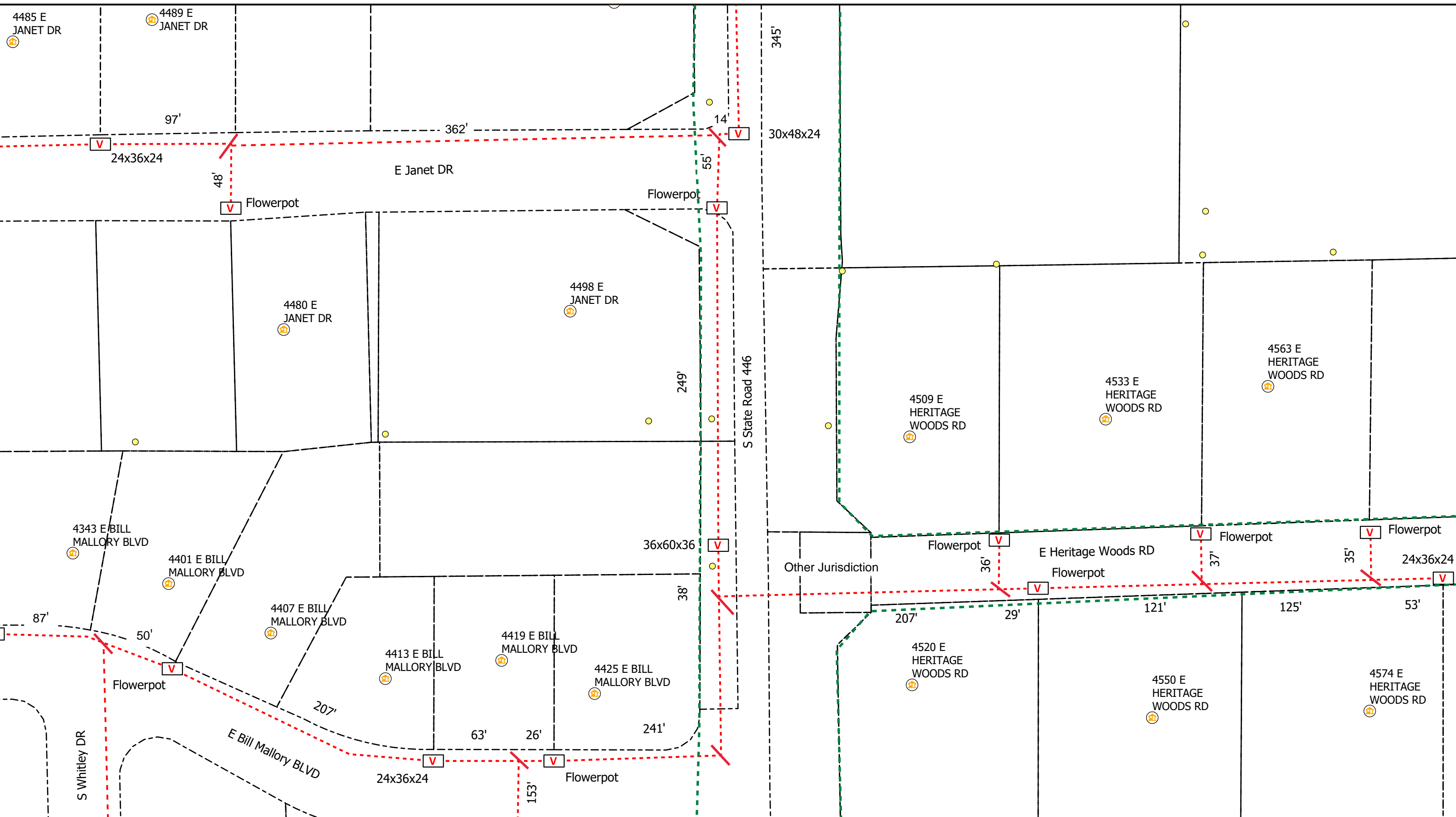

AEG

0 20 40 80 Feet

Legend

- Poles
- V Vaults
- Overhead Strand
- Conduit
- Bloomington_Parcels
- R Risers
- Ⓜ Address
- Other Jurisdiction
- Y Anchor
- ← Sidewalk
- Grids

All Flowerpots 12" DIA

N

City of Bloomington, IN Permit:
Design View

INI	BY	DATE	DESCRIPTION

Print 7 of 16

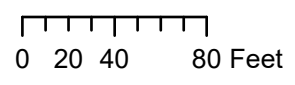
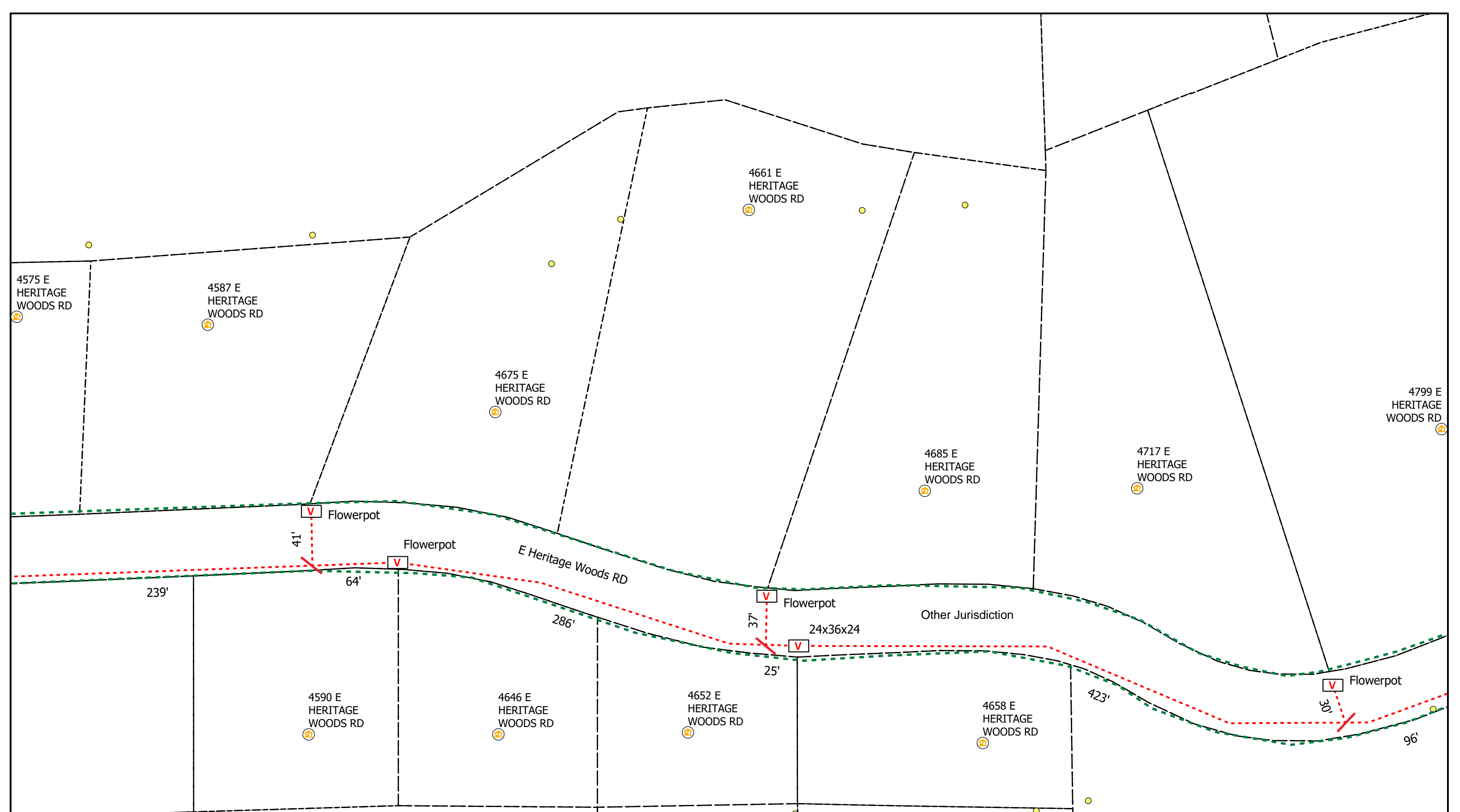

Legend

- Poles
- V Vaults
- Overhead Strand
- Conduit
- Bloomington_Parcels
- R Risers
- A Address
- Other Jurisdiction
- Y Anchor
- ← Sidewalk
- Grids

All Flowerpots 12" DIA



City of Bloomington, IN Permit:
Design View

INI	BY	DATE	DESCRIPTION



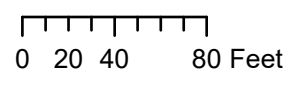
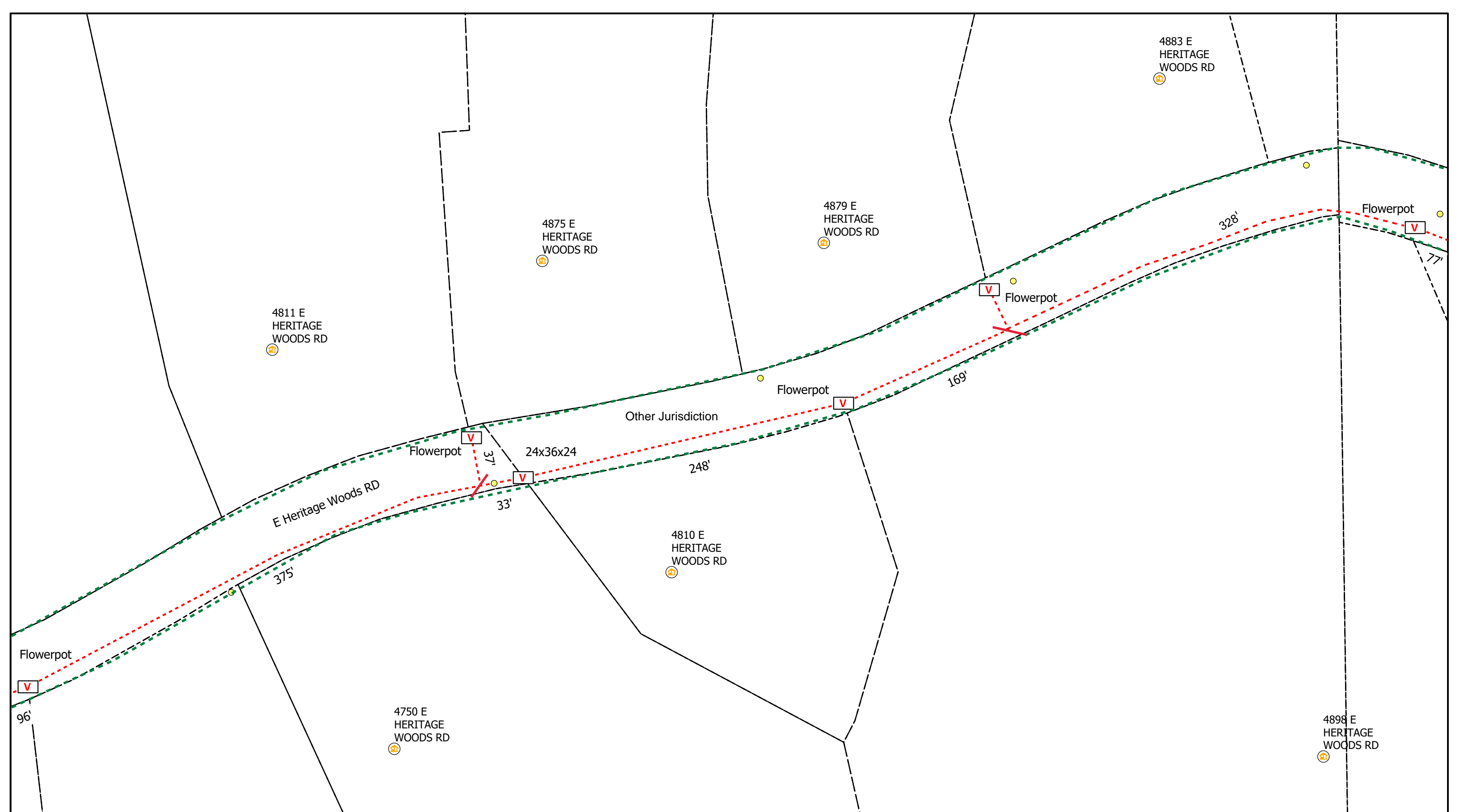

Legend

- Poles
- Vaults
- Overhead Strand
- Conduit
- Other Jurisdiction
- Bloomington_Parcels
- Risers
- Address
- Grids
- Anchor
- Sidewalk

All Flowerpots 12" DIA



City of Bloomington, IN Permit:
Design View

INI	BY	DATE	DESCRIPTION



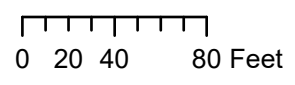
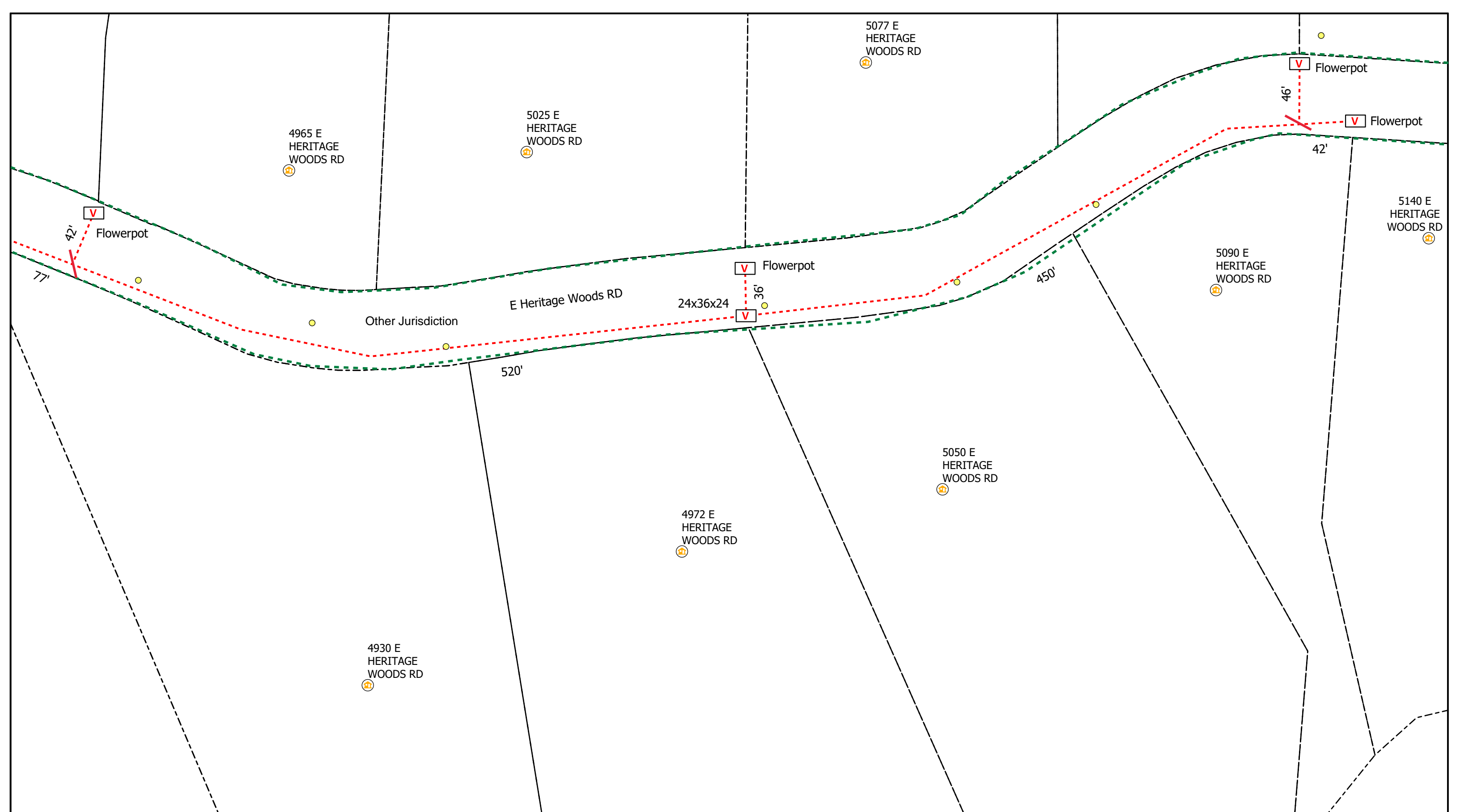

Legend

- Poles
- V Vaults
- Overhead Strand
- - - Conduit
- Bloomington_Parcels
- Ⓜ Risers
- Ⓜ Address
- - - Other Jurisdiction
- Y Anchor
- ← Sidewalk
- Grids

All Flowerpots 12" DIA



City of Bloomington, IN Permit:
Design View

INI	BY	DATE	DESCRIPTION



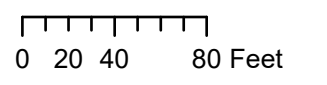
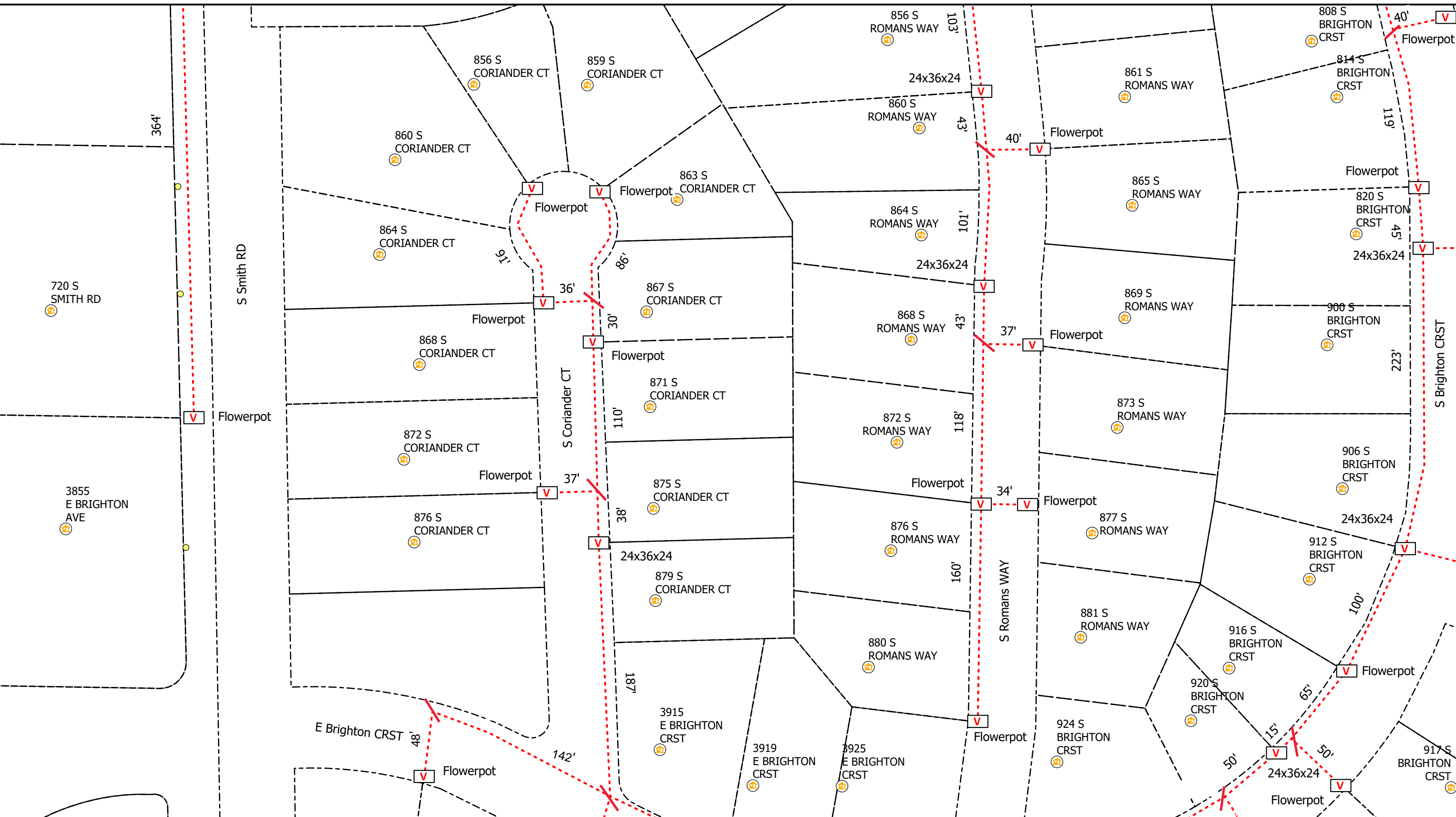

Legend

- Poles
- Vaults
- Overhead Strand
- Conduit
- Bloomington_Parcels
- Risers
- Address
- Other Jurisdiction
- Anchor
- Sidewalk
- Grids

All Flowerpots 12" DIA



City of Bloomington, IN Permit:
Design View

INI	BY	DATE	DESCRIPTION



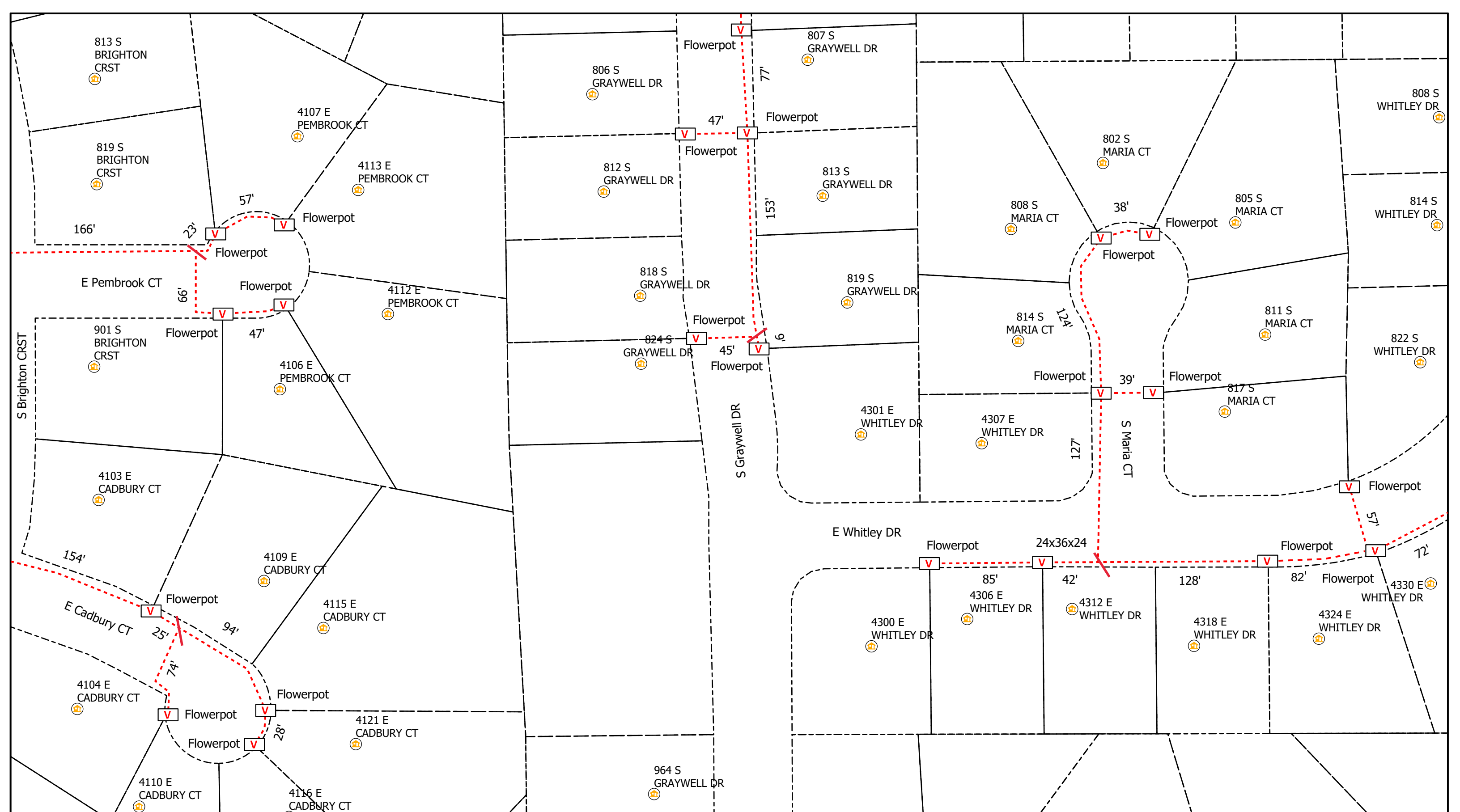

0 20 40 80 Feet

Legend

- Poles
- Vaults
- Overhead Strand
- Conduit
- Bloomington_Parcels
- Risers
- Address
- Other Jurisdiction
- Anchor
- Sidewalk
- Grids

All Flowerpots 12" DIA



City of Bloomington, IN Permit:
Design View

INI	BY	DATE	DESCRIPTION



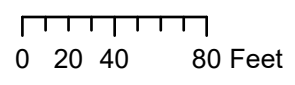
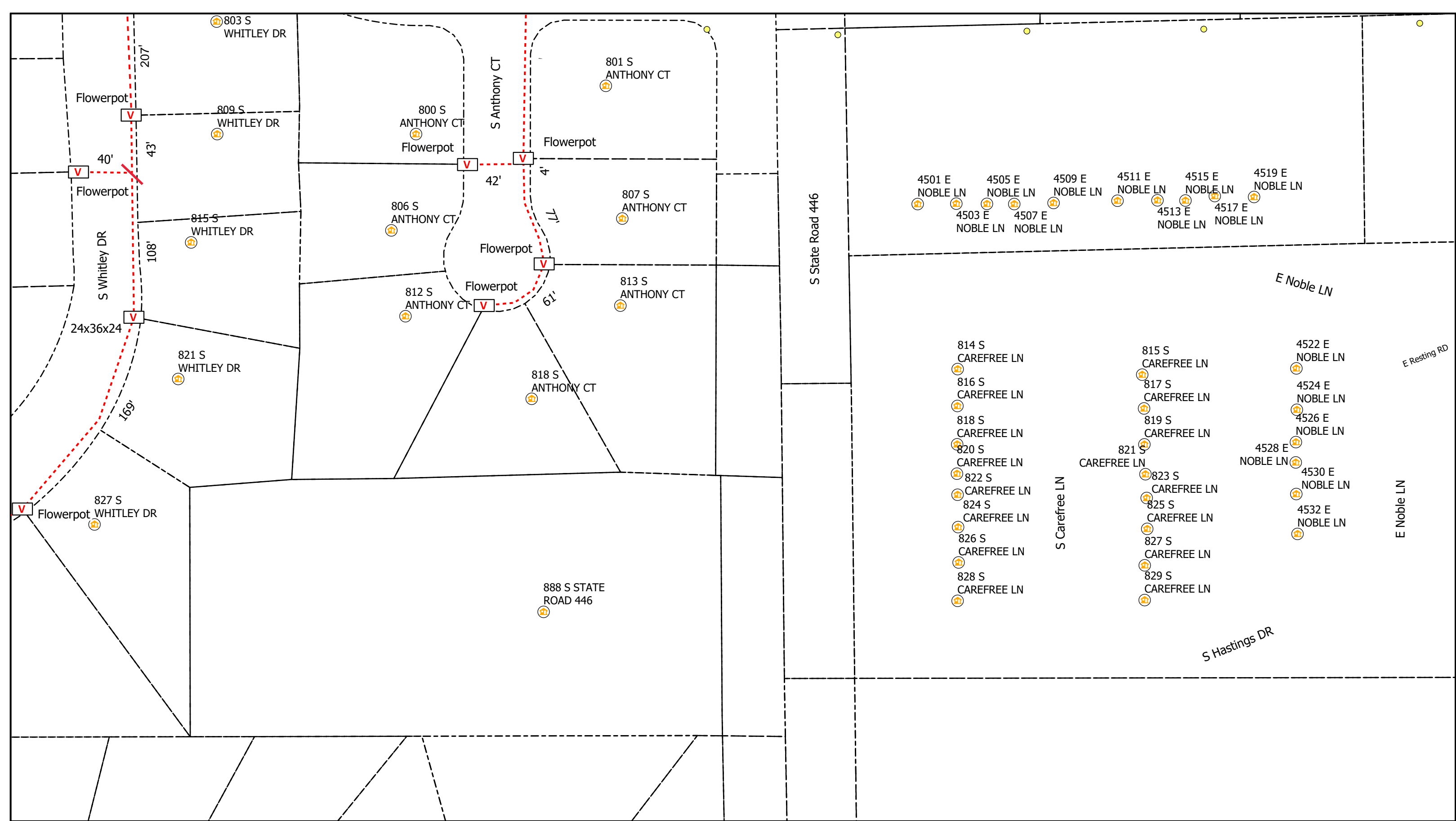

Legend

- Poles
- Vaults
- Overhead Strand
- Conduit
- Bloomington_Parcels
- Risers
- Address
- Other Jurisdiction
- Anchor
- Sidewalk
- Grids

All Flowerpots 12" DIA



City of Bloomington, IN Permit:
Design View

INI	BY	DATE	DESCRIPTION



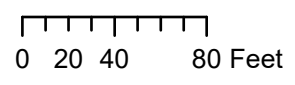
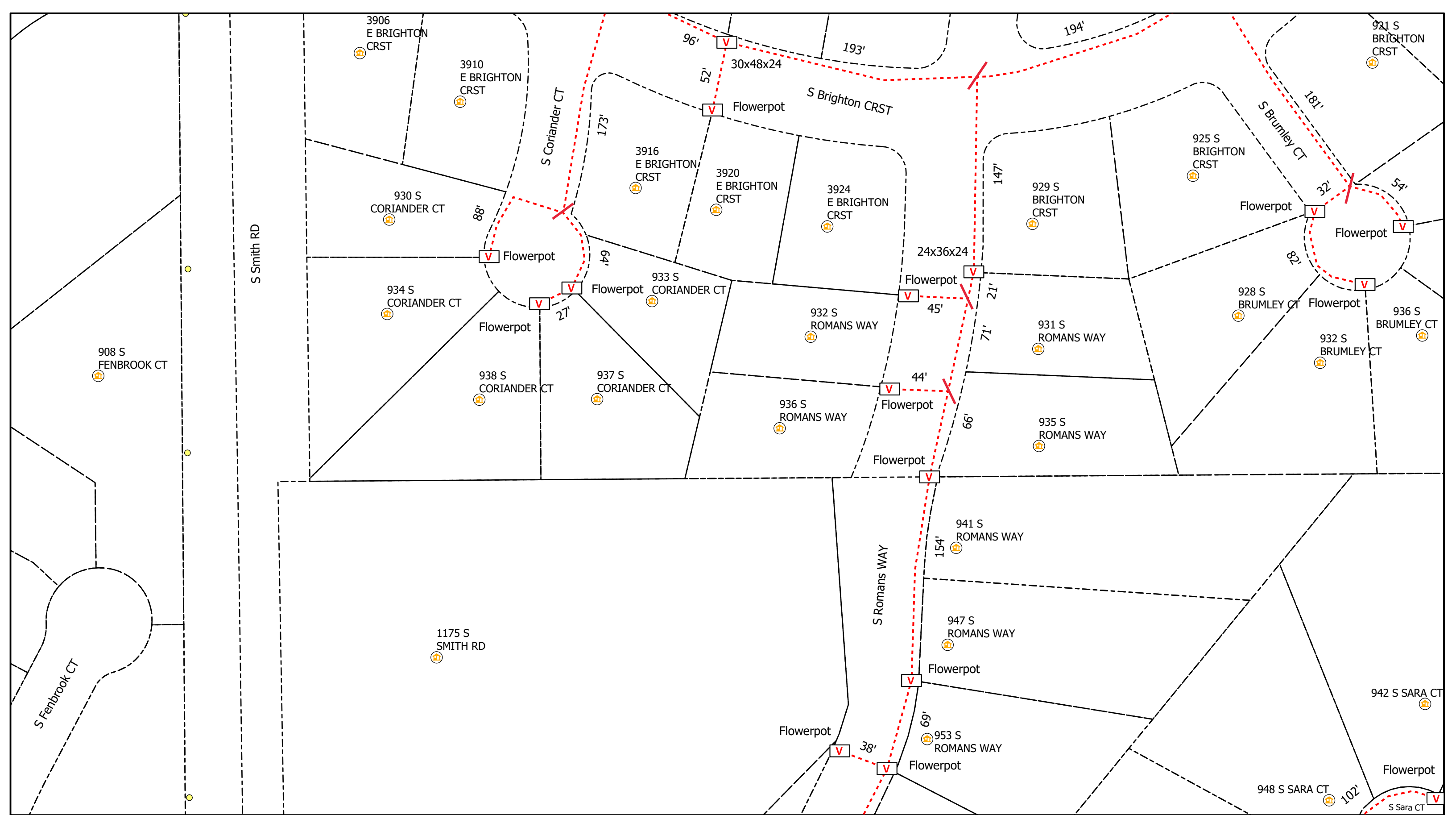

Legend

- Poles
- Vaults
- Overhead Strand
- Conduit
- Bloomington_Parcels
- Risers
- Address
- Other Jurisdiction
- Anchor
- Sidewalk
- Grids

All Flowerpots 12" DIA



City of Bloomington, IN Permit:
Design View

INI	BY	DATE	DESCRIPTION



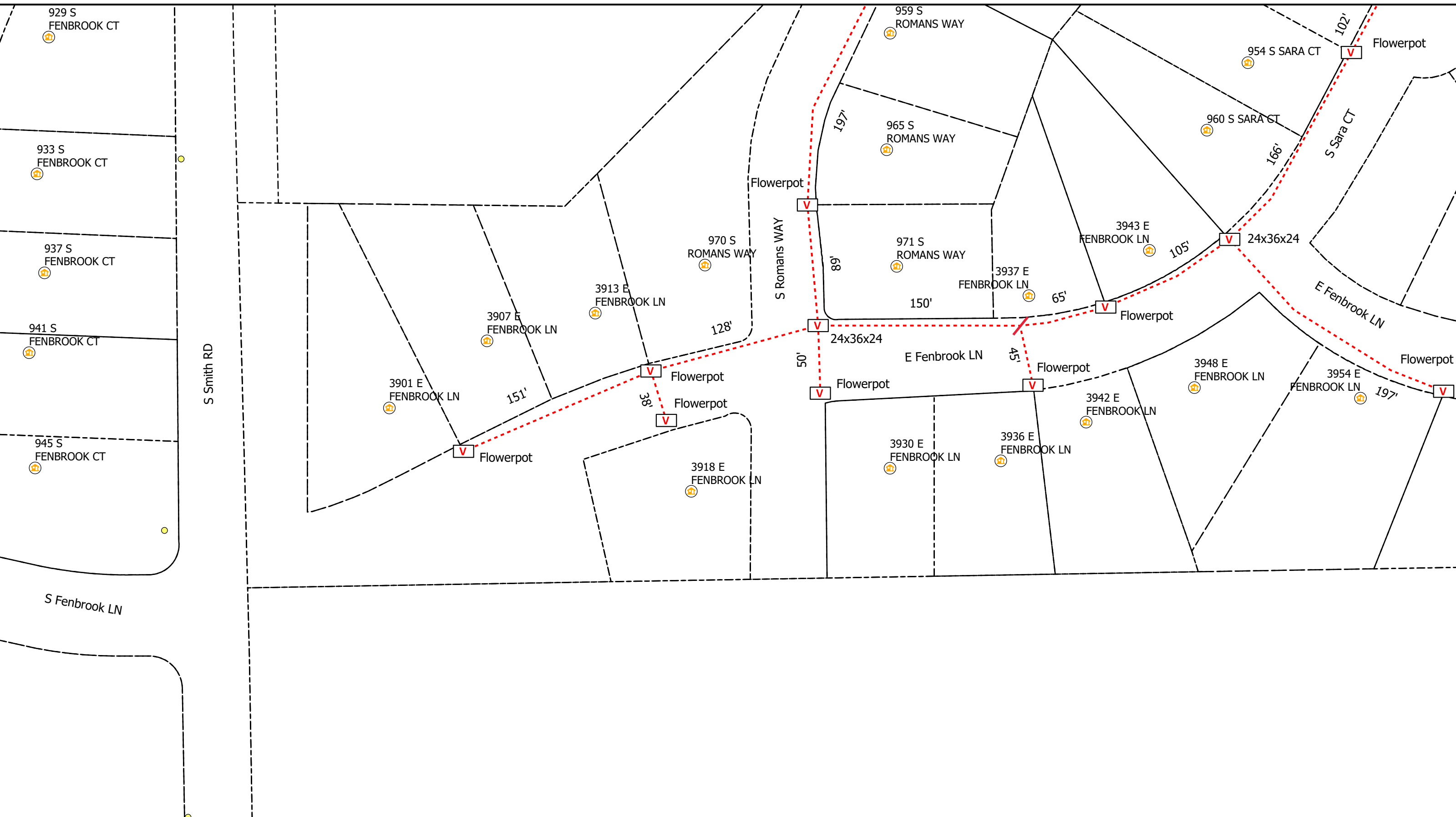

Legend

- Poles
- V Vaults
- Overhead Strand
- Conduit
- Bloomington_Parcels
- R Risers
- Ⓜ Address
- Other Jurisdiction
- Y Anchor
- ← Sidewalk
- Grids

All Flowerpots 12" DIA



City of Bloomington, IN Permit:
Design View

INI	BY	DATE	DESCRIPTION



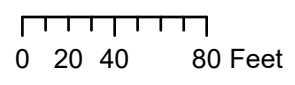
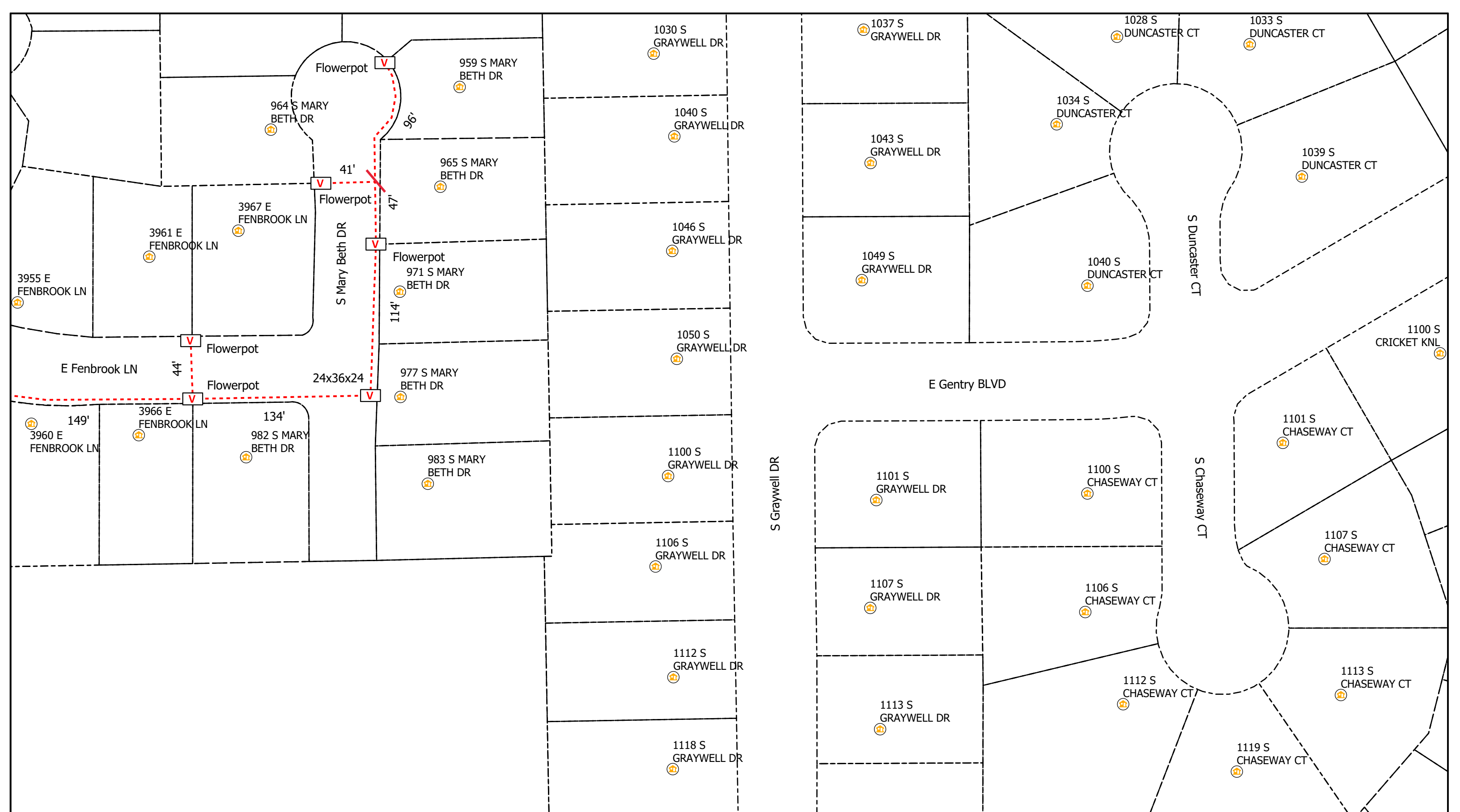

Legend

- Poles
- V Vaults
- Overhead Strand
- Conduit
- Bloomington_Parcels
- R Risers
- Ⓜ Address
- Other Jurisdiction
- Y Anchor
- ← Sidewalk
- Grids

All Flowerpots 12" DIA



City of Bloomington, IN Permit:
Design View

INI	BY	DATE	DESCRIPTION



CONCEPTUAL SIDE VIEW

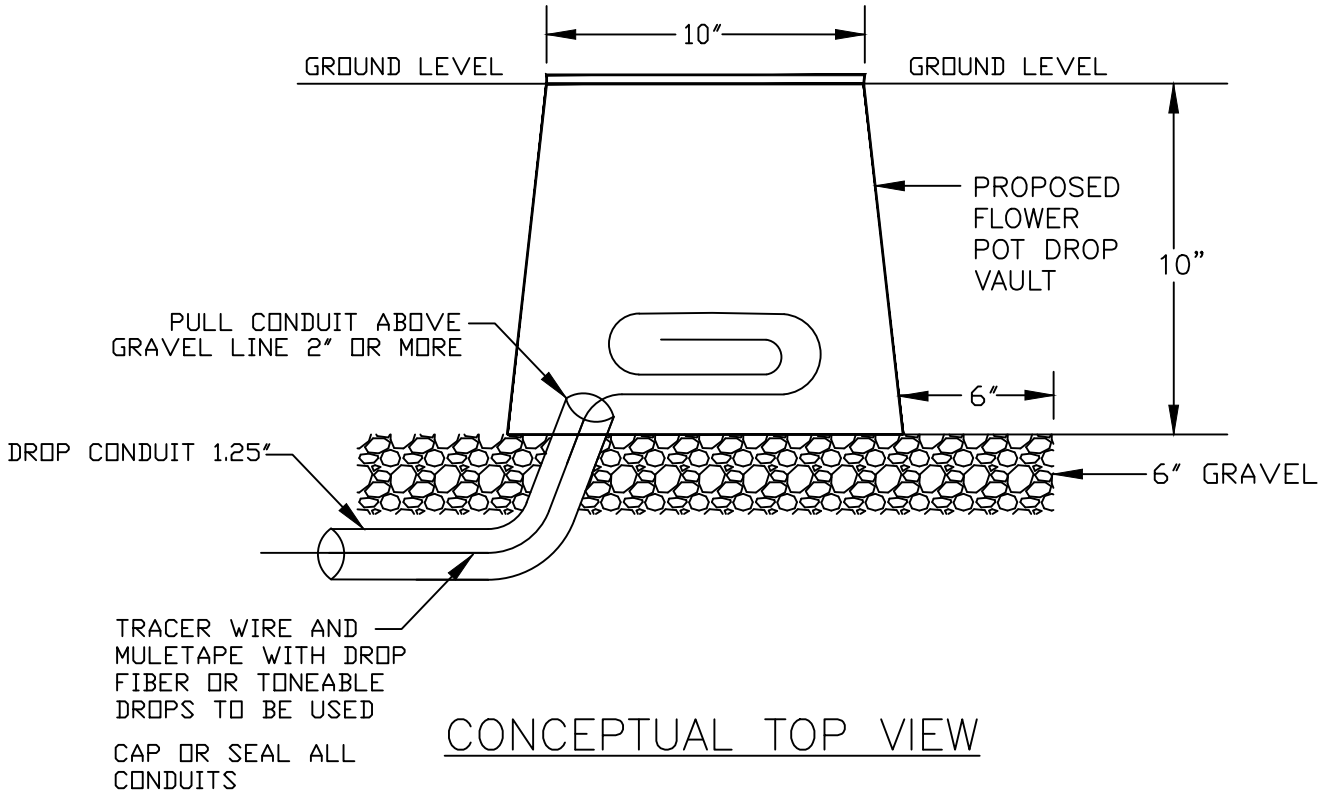

CONCEPTUAL TOP VIEW

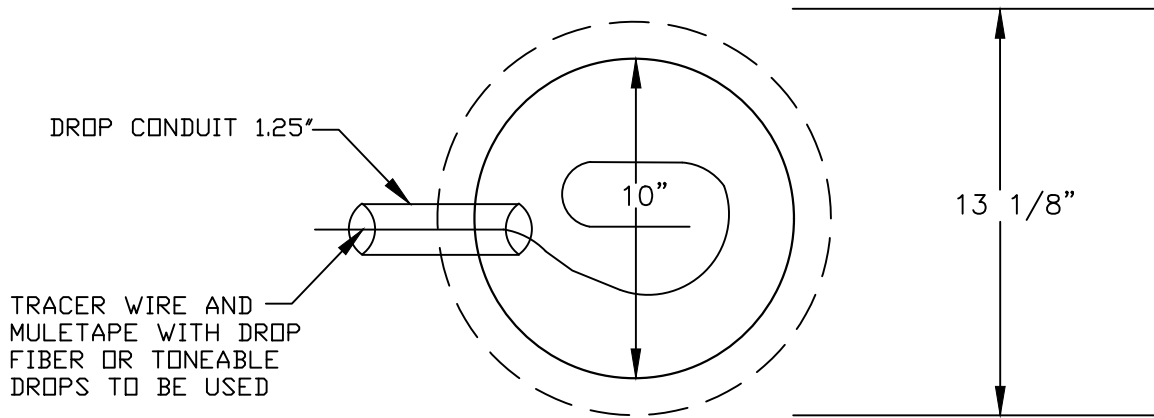

FLOWER POT

30"x48" PC UNIT, 2PC TIER 15/22
 18", 24", and 36" HEIGHT



AMERICAN POLYMER COMPANY

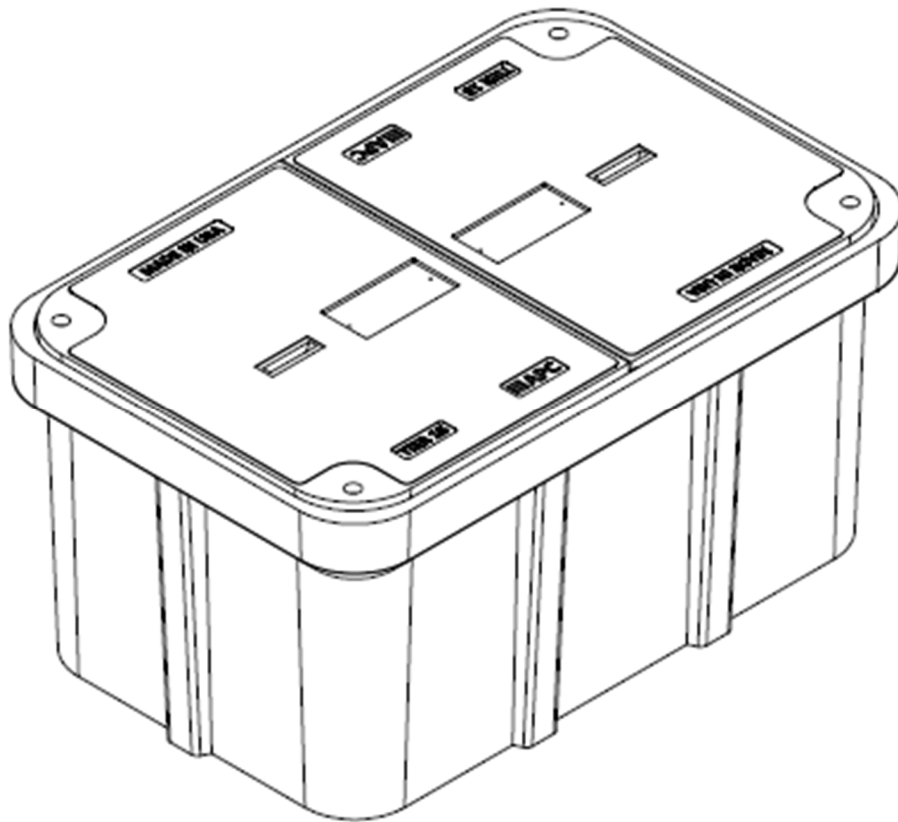

Description	Nominal Size	ANSI Tier	Part Number	Estimated Weight
PC Unit – TIER 15	30"x48"x18"	Tier 15	P304818HU15...	460 lbs.
PC Unit – TIER 22	30"x48"x18"	Tier 22	P304818HU22...	525 lbs.
PC Unit – TIER 15	30"x48"x24"	Tier 15	P304824HU15...	510 lbs.
PC Unit – TIER 22	30"x48"x24"	Tier 22	P304824HU22...	575 lbs.
PC Unit – TIER 15	30"x48"x36"	Tier 15	P304836HU15...	615 lbs.
PC Unit – TIER 22	30"x48"x36"	Tier 22	P304836HU22...	680 lbs.



30"x48" PC UNIT, 2PC TIER 15/22

18", 24", and 36" HEIGHT



AMERICAN POLYMER COMPANY

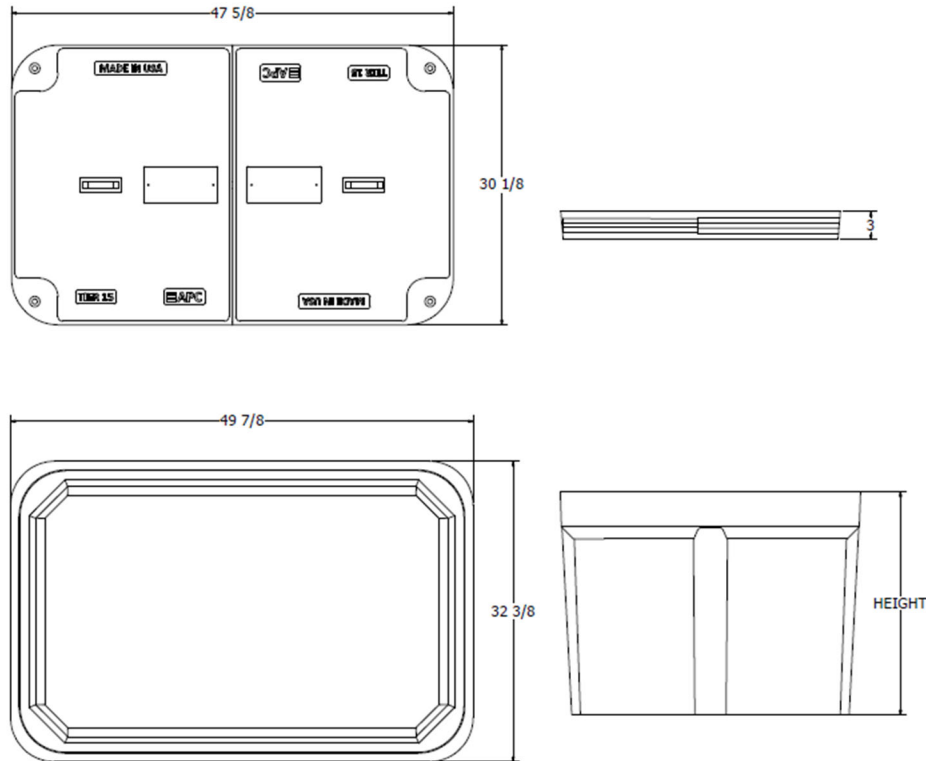

Components	Nominal Size	ANSI Tier	Part Number	Estimated Weight
Replacement Box	30"x48"x18"	Tier 22	P304818B22	185 lbs.
Replacement Box	30"x48"x24"	Tier 22	P304824B22	235 lbs.
Replacement Box	30"x48"x36"	Tier 22	P304836B22	340 lbs.
Replacement Lids - T15	30"x48" (half)	Tier 15	Various	150 lbs.
Replacement Lids - T22	30"x48" (half)	Tier 22	Various	170 lbs.

Bolt options



Machine Thread



Auger Thread



24"x36" PC UNIT, TIER 15/22
 18", 24", 30", and 36" HEIGHT



AMERICAN POLYMER COMPANY

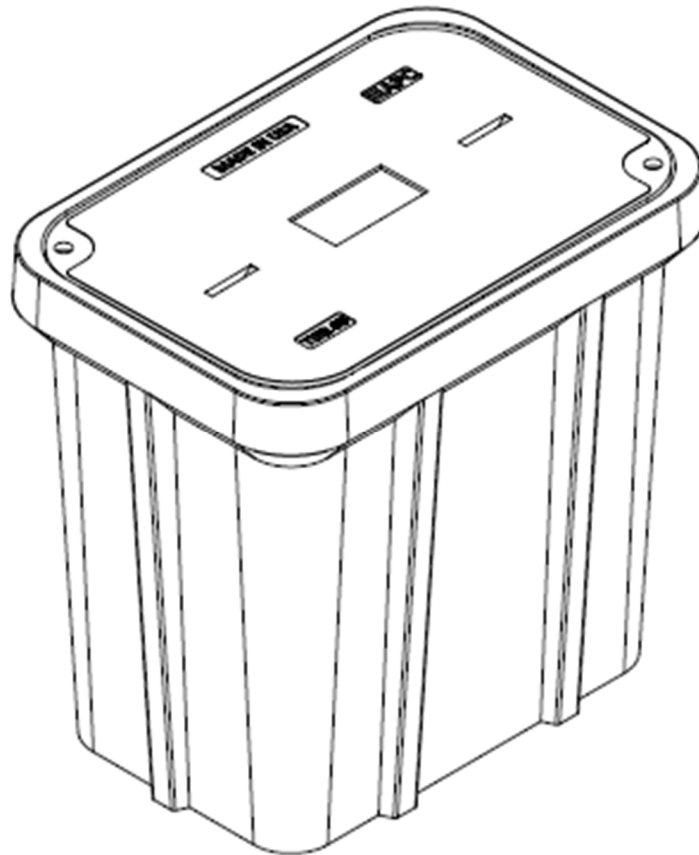

Description	Nominal Size	ANSI Tier	Part Number	Estimated Weight
PC Unit – TIER 15	24x36"x18"	Tier 15	P243618U15...	335 lbs.
PC Unit – TIER 22	24x36"x18"	Tier 22	P243618U22...	355 lbs.
PC Unit – TIER 15	24x36"x24"	Tier 15	P243624U15...	365 lbs.
PC Unit – TIER 22	24x36"x24"	Tier 22	P243624U22...	385 lbs.
PC Unit – TIER 15	24x36"x30"	Tier 15	P243630U15...	395 lbs.
PC Unit – TIER 22	24x36"x30"	Tier 22	P243630U22...	415 lbs.
PC Unit – TIER 15	24x36"x36"	Tier 15	P243636U15...	425 lbs.
PC Unit – TIER 22	24x36"x36"	Tier 22	P243636U22...	445 lbs.



24"x36" PC UNIT, TIER 15/22

18", 24", 30", and 36" HEIGHT



AMERICAN POLYMER COMPANY

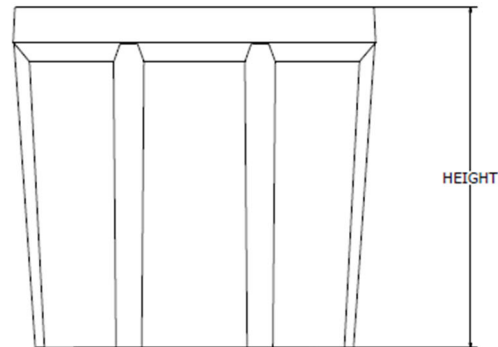
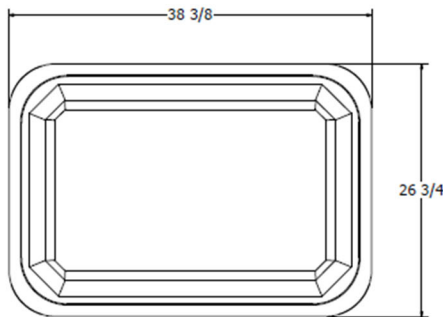
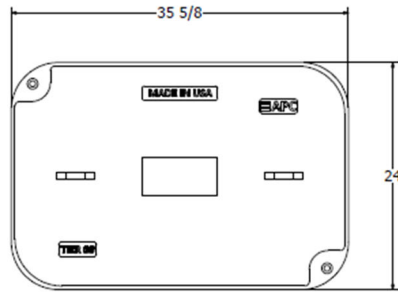

Components	Nominal Size	ANSI Tier	Part Number	Estimated Weight
Replacement Box	24"x36"x18"	Tier 22	P243618B22	165 lbs.
Replacement Box	24"x36"x24"	Tier 22	P243624B22	195 lbs.
Replacement Box	24"x36"x30"	Tier 22	P243630B22	225 lbs.
Replacement Box	24"x36"x36"	Tier 22	P243636B22	255 lbs.
Replacement Lids - T15	24"x36"	Tier 15	Various	170 lbs.
Replacement Lids - T22	24"x36"	Tier 22	Various	190 lbs.

Bolt options

Hex Head



Machine Thread



Penta Head



Auger Thread



17"x30" PC UNIT, TIER 15/22

12", 18", 24", and 30" HEIGHT



AMERICAN POLYMER COMPANY

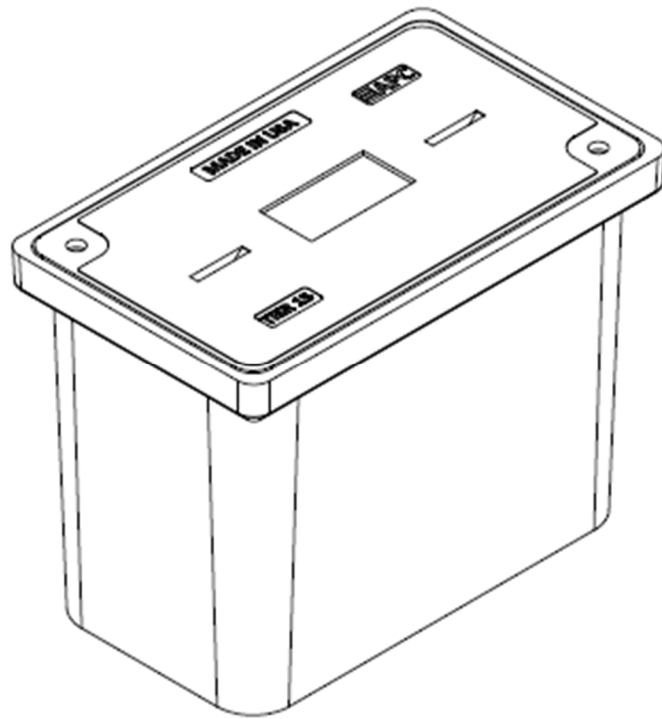

Description	Nominal Size	ANSI Tier	Part Number	Estimated Weight
PC Unit – TIER 15	17"x30"x12"	Tier 15	P173012U15...	138 lbs.
PC Unit – TIER 22	17"x30"x12"	Tier 22	P173012U22...	147 lbs.
PC Unit – TIER 15	17"x30"x18"	Tier 15	P173018U15...	172 lbs.
PC Unit – TIER 22	17"x30"x18"	Tier 22	P173018U22...	181 lbs.
PC Unit – TIER 15	17"x30"x24"	Tier 15	P173024U15...	192 lbs.
PC Unit – TIER 22	17"x30"x24"	Tier 22	P173024U22...	201 lbs.
PC Unit – TIER 15	17"x30"x30"	Tier 15	P173030U15...	217 lbs.
PC Unit – TIER 22	17"x30"x30"	Tier 22	P173030U22...	226 lbs.



17"x30" PC UNIT, TIER 15/22

12", 18", 24", and 30" HEIGHT



AMERICAN POLYMER COMPANY

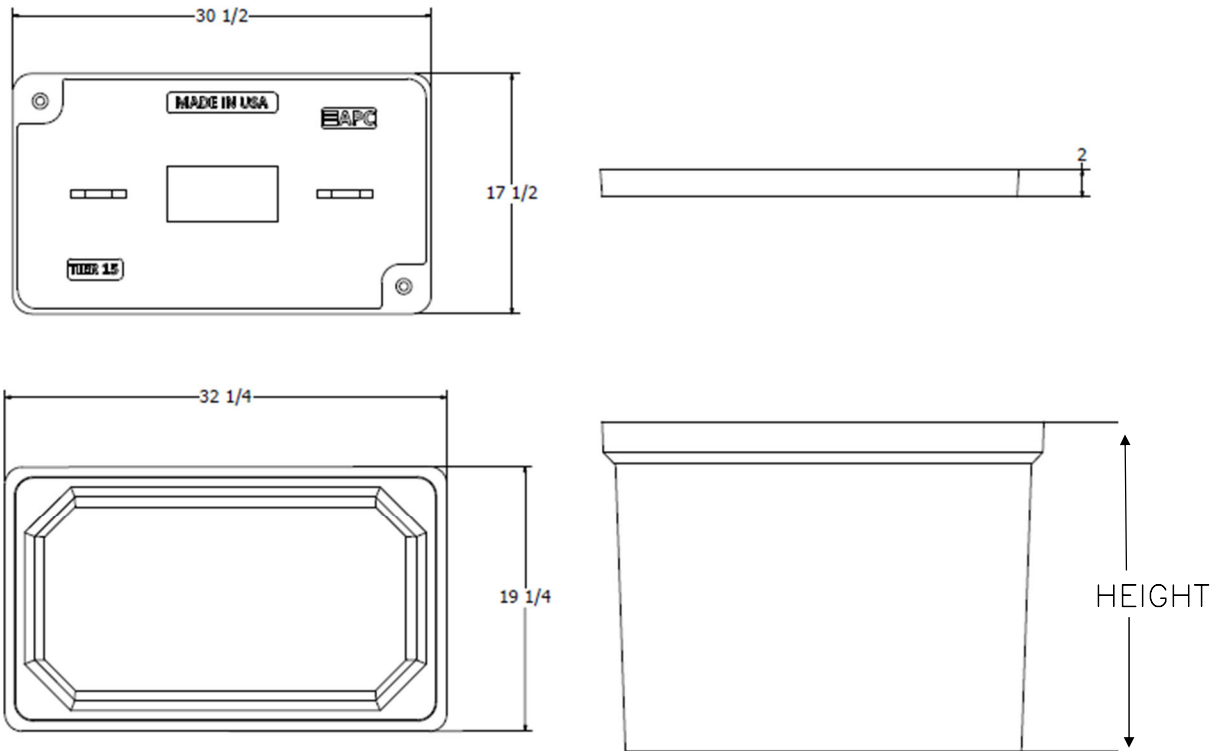

Components	Nominal Size	ANSI Tier	Part Number	Estimated Weight
Replacement Box	17"x30"X12"	Tier 22	P173012B22	66 lbs.
Replacement Box	17"x30"X18"	Tier 22	P173018B22	100 lbs.
Replacement Box	17"x30"X24"	Tier 22	P173024B22	120 lbs.
Replacement Box	17"x30"X30"	Tier 22	P173030B22	145 lbs.
Replacement Lids – T15	17"x30"	Tier 15	Various	72 lbs.
Replacement Lids – T22	17"x30"	Tier 22	Various	81 lbs.

Bolt options



Machine Thread



Auger Thread



33"x60" PC UNIT, 2PC TIER 15/22
36" HEIGHT



AMERICAN POLYMER COMPANY

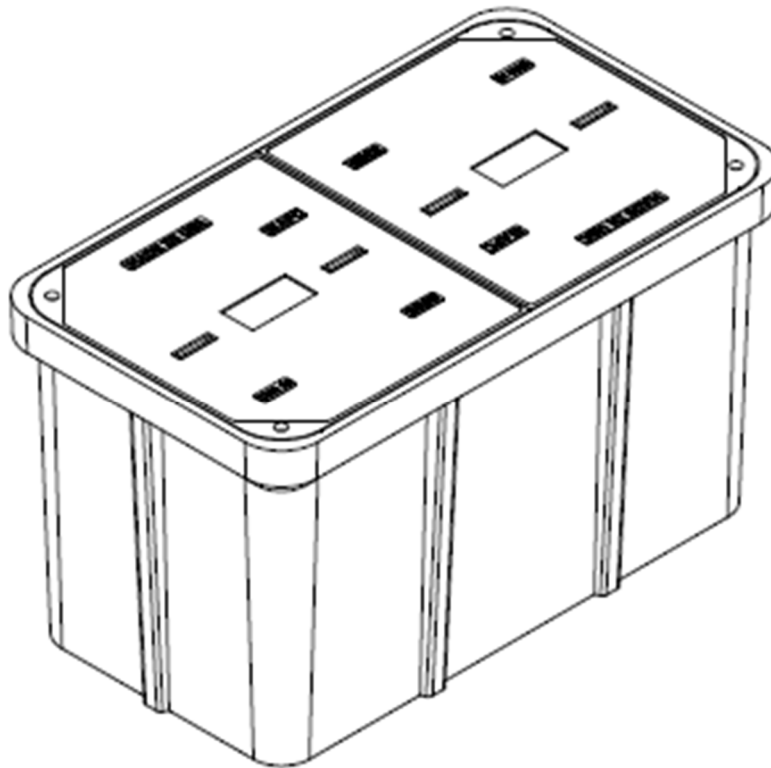

Description	Nominal Size	ANSI Tier	Part Number	Estimated Weight
PC Unit - TIER 15	33"x60"x36"	Tier 15	P336036U15...	930 lbs.
PC Unit - TIER 22	33"x60"x36"	Tier 22	P336036U22...	1030 lbs.



33"x60" PC UNIT, 2PC TIER 15/22

36" HEIGHT



AMERICAN POLYMER COMPANY

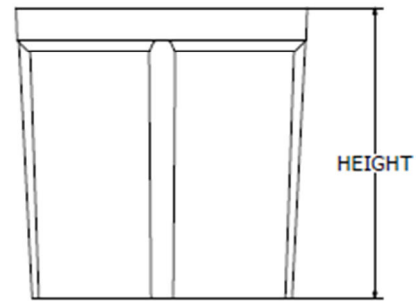
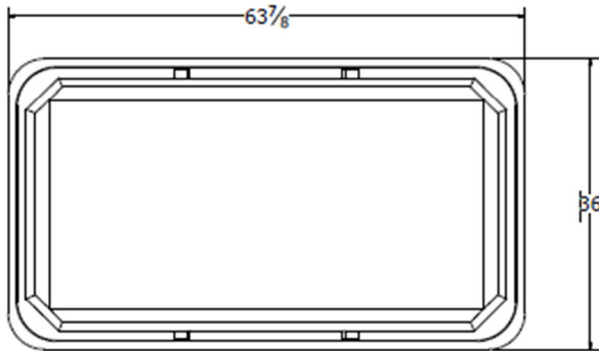
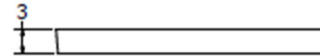

Components	Nominal Size	ANSI Tier	Part Number	Estimated Weight
Replacement Box	33"x60"x36"	Tier 22	P336036B22	530 lbs.
Replacement Lids - T15	33"x60" (half)	Tier 15	Various	200 lbs.
Replacement Lids - T22	33"x60" (half)	Tier 22	Various	250 lbs.

Bolt options

Hex Head



Machine Thread



Penta Head



Auger Thread



Speed (MPH) Prior To Road Work	SIGN SPACING, FT.		Must be Approved by an Engineer				
	Non-Divided Highways	Divided Highways	BUFFER SPACE, FT.	TAPER LENGTH, FT.	CHANNELIZING SPACING, FT.		
	Length	Shoulder (10 ft. Width)	Lane (12 ft. Width)	Through Taper	Through Buffer/Work Area		
0-35	200	200	250	70	245	35	50
40-45	350	500	360	150	540	40	80
50-55	500	1000	495	185	660	50	100
60-70	SA-1000, SB-1500, SC-2640		730	235	840	60	120
	Urban Low Speed - 100 FT						

APPROVED/ACCEPTED BY:
ENGINEER, OWNER, or PRIME CONTRACTOR
 Check for Notice to Proceed.
BLC01b-F16_E Janet Dr TCP

Signature: _____

Company: _____

Date: 10/13/2022 **Project:** BLC01b-F16 E Janet Dr TCP :
: **Traffic Control Suggestion For:** AEG :
By: Road Runner Safety Services, Inc. : Nathan

Comments:
Drawing not to scale. Traffic control plan must be approved by an engineer. This is a suggestion only. Road Runners Safety Services, Inc. has no liability for this suggested traffic control plan. Actual placement and spacing of all traffic control devices will depend on field conditions and must conform to MUTCD standards.

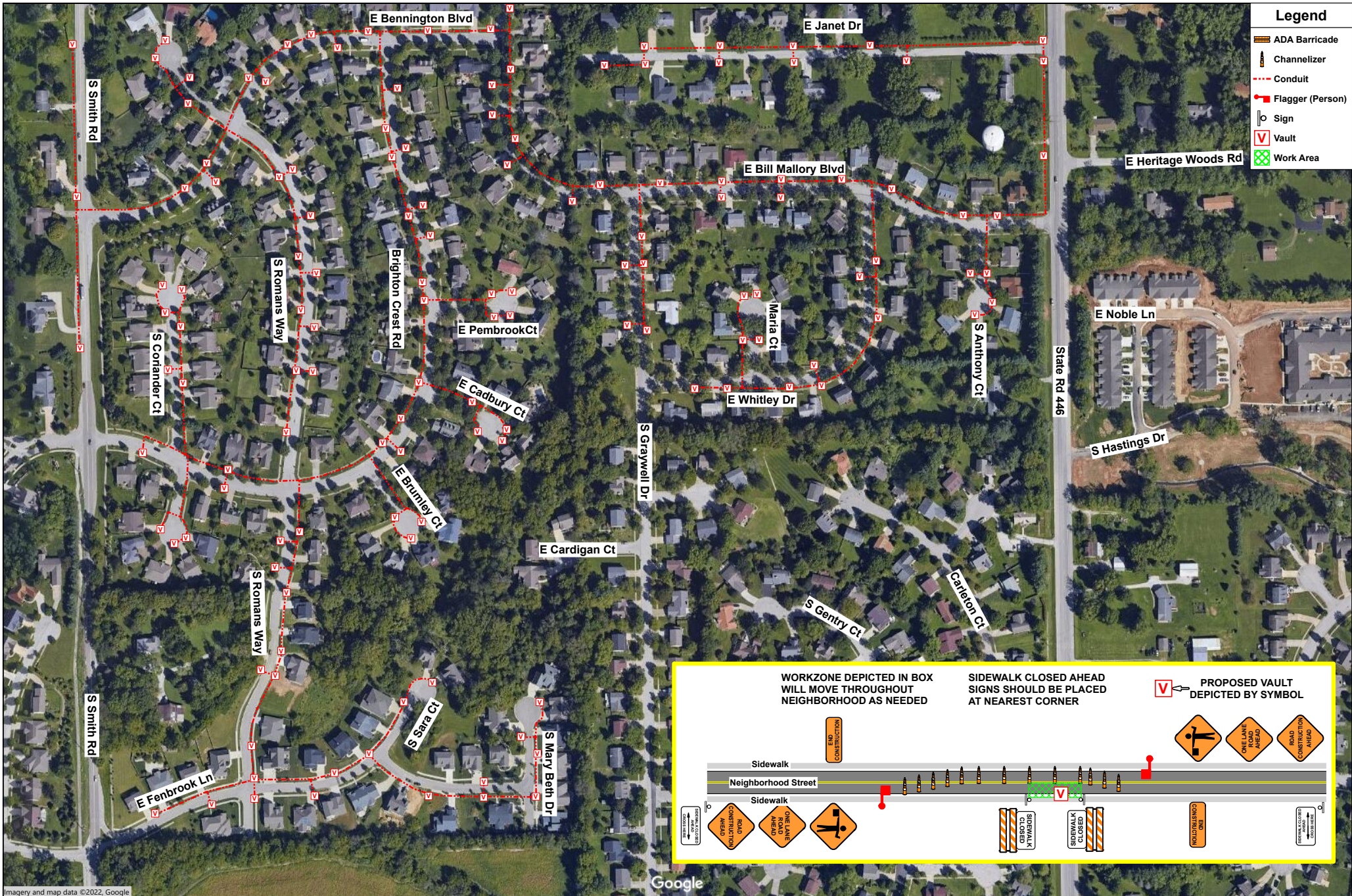



CITY OF BLOOMINGTON RIGHT-OF-WAY USE PERMIT APPLICATION

401 N Morton Street, Suite 130
P.O. Box 100
Bloomington, IN 47402

Phone: (812) 349-3913
Fax: (812) 349-3520
Email:
engineering@bloomington.in.gov

ROW EXCAVATION ROW USE

ADDRESS OF ROW ACTIVITY: E Discovery Parkway

A. APPLICANT/AGENT INFORMATION:		D. TRAFFIC CONTROL DEVICES*:	
APPLICANT NAME: <u>Bret Simons</u>		<input checked="" type="checkbox"/> CONES <input type="checkbox"/> ARROWBOARD	
E-MAIL: <u>bret.simons@aeg.cc</u>		<input type="checkbox"/> LIGHTED BARRELS <input checked="" type="checkbox"/> TYPE 3 BARRICADES	
COMPANY: <u>Atlantic Engineering Group</u>		<input checked="" type="checkbox"/> FLAGGERS <input type="checkbox"/> BPD OFFICER	
ADDRESS: <u>P.O. Box 349</u>		*PROVIDING MUTCD COMPLIANT TEMPORARY TRAFFIC CONTROL DEVICES AND MAINTENANCE OF TRAFFIC (MOT) PLAN IS YOUR RESPONSIBILITY AND REQUIRED. See page 3 for additional MOT resources; the graph paper can be used for your MOT site plan if needed or you can submit a separate sheet	
CITY, STATE, ZIP: <u>Buford, GA 30515</u>			
24-HR EMERGENCY CONTACT NAME: <u>(706)654-2298</u>		E. METERED PARKING SPACES NEEDED: <input type="checkbox"/> Y <input type="checkbox"/> N	
24-HR CONTACT PHONE #: _____		IT IS THE RESPONSIBILITY OF THE APPLICANT TO RESERVE PARKING METER(S) APPLICATION LOCATED: https://bloomington.in.gov/transportation/parking/moving OR CONTACT PARKING SERVICES WITH QUESTIONS AT (812)349-3436	
INSURANCE #*: <u>TB5-691-473497-082</u> COMPANY: <u>ACORD</u>		F. IS THIS A <input type="checkbox"/> CBU* <input type="checkbox"/> COUNTY* <input type="checkbox"/> IU* <input type="checkbox"/> NP* PROJECT?	
BOND#: <u>1160465</u> COMPANY: <u>LEXON</u>		PROJECT NAME: <u>BLC01b-F15 E Gentry Blvd</u>	
*INSURANCE & BOND MUST BE ON FILE WITH THE CITY BEFORE PERMIT WILL BE ISSUED		PROJECT #: <u>BLC01b-F15 E Gentry Blvd</u>	
SUBCONTRACTOR INFORMATION		PROJECT MGR.: <u>Lex Mullins</u>	
(LIST ALL COMPANIES WORKING UNDER PRIMARY CONTRACTOR PERMIT)		PROJECT MGR. #: <u>215-847-8819</u>	
COMPANY NAME: _____		*CBU = CITY OF BLOOMINGTON UTILITIES *COUNTY = MONROE COUNTY	
B. WORK DESCRIPTION:		*IU = INDIANA UNIVERSITY *NP = NOT-FOR-PROFIT AGENCY	
<input type="checkbox"/> POD/DUMPSTER <input type="checkbox"/> CRANE <input type="checkbox"/> SCAFFOLDING <input checked="" type="checkbox"/> CONSTRUCTION USE*		G. EXCAVATIONS:	
(EXPLAIN): <u>Excavation</u>		SQ FT OF PAVEMENT* EXCAVATIONS: <u>N/A</u>	
*EXCAVATION, LONG TERM USE FOR STORAGE OF MATERIAL/EQUIPMENT/WALKAROUND		*PAVEMENT INCLUDES: IN OR UNDER CONCRETE, OR ASPHALT INCLUDING CURBS	
C. RIGHT OF WAY TO BE USED/CLOSED:		SQ FT OF NON-PAVEMENT* EXCAVATIONS: <u>42 Sq ft</u>	
STREET NAME 1: <u>E Discovery Parkway</u>		*DIRT, GRASS, GRAVEL, LANDSCAPE AREA OR OTHER UNPAVED SURFACE	
1ST INTERSECTING STREET NAME: _____		LINEAL FT OF BORE*: <u>3,376 Lineal Ft</u>	
2ND INTERSECTING STREET NAME: _____		*BORE PITS SHALL BE CALCULATED AS SQ FT EXCAVATIONS	
<input type="checkbox"/> ROAD CLOSURE <input checked="" type="checkbox"/> LANE CLOSURE 1 <input checked="" type="checkbox"/> 2 <input type="checkbox"/> 3 <input type="checkbox"/>		# OF POLE INSTALLATIONS/REMOVAL: <u>N/A</u>	
<input checked="" type="checkbox"/> SIDEWALK* <input type="checkbox"/> BIKE LANE <input type="checkbox"/> OTHER		SQ FT OF SIDEWALK RECONSTRUCTION*: <u>N/A</u>	
TRANSIT STOP? <input type="checkbox"/> Y <input type="checkbox"/> N PARKING LANE(S)** <input type="checkbox"/> Y <input type="checkbox"/> N **NON-METERED		*CONCRETE OR ASPHALT SIDEWALK/PATH BEING IMPROVED/REPLACED	
START DATE: <u>Oct 28th</u> END DATE: _____ # OF DAYS*: <u>30</u>		SQ FT OF SIDEWALK NEW CONSTRUCTION*: <u>N/A</u>	
STREET NAME 2: _____		*CONCRETE OR ASPHALT SIDEWALK/PATH THAT IS NEW INFRASTRUCTURE	
1ST INTERSECTING STREET NAME: _____		#RESIDENTIAL DRIVEWAY INSTALLATION: <u>N/A</u>	
2ND INTERSECTING STREET NAME: _____		 <p>TO SUBMIT A LOCATE REQUEST 24 HRS A DAY, 7 DAYS A WEEK CALL 811 OR 800-382-5544 CALL 2 WORKING DAYS BEFORE YOU DIG. IT'S THE LAW.</p>	
<input type="checkbox"/> ROAD CLOSURE <input type="checkbox"/> LANE CLOSURE 1 <input type="checkbox"/> 2 <input type="checkbox"/> 3 <input type="checkbox"/>			
<input type="checkbox"/> SIDEWALK* <input type="checkbox"/> BIKE LANE <input type="checkbox"/> OTHER		H. INDEMNIFICATION AGREEMENT:	
TRANSIT STOP? <input type="checkbox"/> Y <input type="checkbox"/> N PARKING LANE(S)** <input type="checkbox"/> Y <input type="checkbox"/> N **NON-METERED		The petitioner/applicant hereby agrees to hold harmless, defend and to indemnify the City of Bloomington from or against all claims, action, damages and expenses, including but not limited to reasonable attorney's fees or any alleged injury and/or death to any person or damage to any property arising, or alleged to have arisen out of any act of commission or omission on the part of the petitioner/applicant, his/her heirs, successors, or assigns regardless of whether such acts are the direct or indirect result of the public right-of-way use pursuant to this permit grant.	
START DATE: _____ END DATE: _____ # OF DAYS*: _____		I AFFIRM, UNDER THE PENALTIES FOR PERJURY, THAT THE FOREGOING REPRESENTATIONS ARE TRUE.	
*SIDEWALK CLOSURES FOR A PERIOD OR PERIODS TOTALING 24HRS OR MORE SHALL INSTALL A WALKAROUND UNLESS OTHERWISE APPROVED DURING REVIEW		PRINT NAME: <u>Bret Simons</u>	
STANDARD CLOSURE HOURS MON-FRI*: 9:00 AM - 3:00 PM & 6:00 PM - 9:00 PM		SIGNATURE: <u>Bret Simons</u>	
STANDARD CLOSURE HOURS <input checked="" type="checkbox"/> *NON-STANDARD CLOSURE HOURS <input type="checkbox"/>		DATE: <u>10/17/2022</u>	
REQUESTED CLOSURE HOURS: _____ AM - _____ PM			
*non-standard hours may not be allowed near schools, on arterials, or other circumstances and are subject to approval during the permitting process			
BMC 14.09.040 allows work from 6 AM to 10 PM without violating the noise ordinance (7AM to 9PM for pneumatic hammers)			







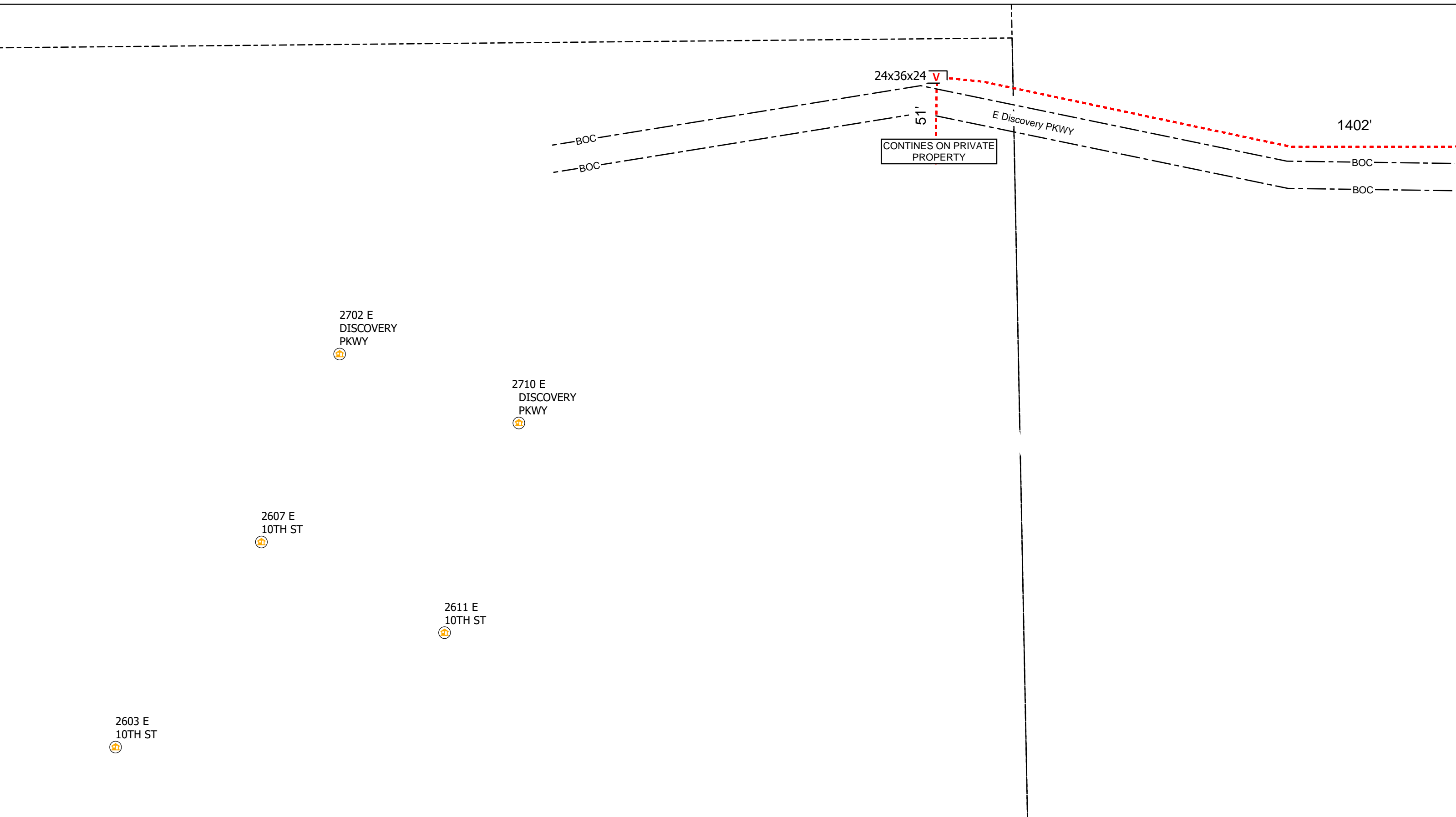

For Administration Use Only (applicable to CLOSURE approval)

Approved By: _____ BPW City Engineer Director Date: _____

Staff Representative: _____ Phone#: _____ Date: _____



Legend

-  Vaults
-  Overhead Strand
-  Conduit
-  Bloomington_Parcels
-  Risers
-  Address
-  Anchor
-  Sidewalk



0 20 40 80 Feet

All Flowerpots 12" DIA



City of Bloomington, IN Permit:
Design View

INI	BY	DATE	DESCRIPTION



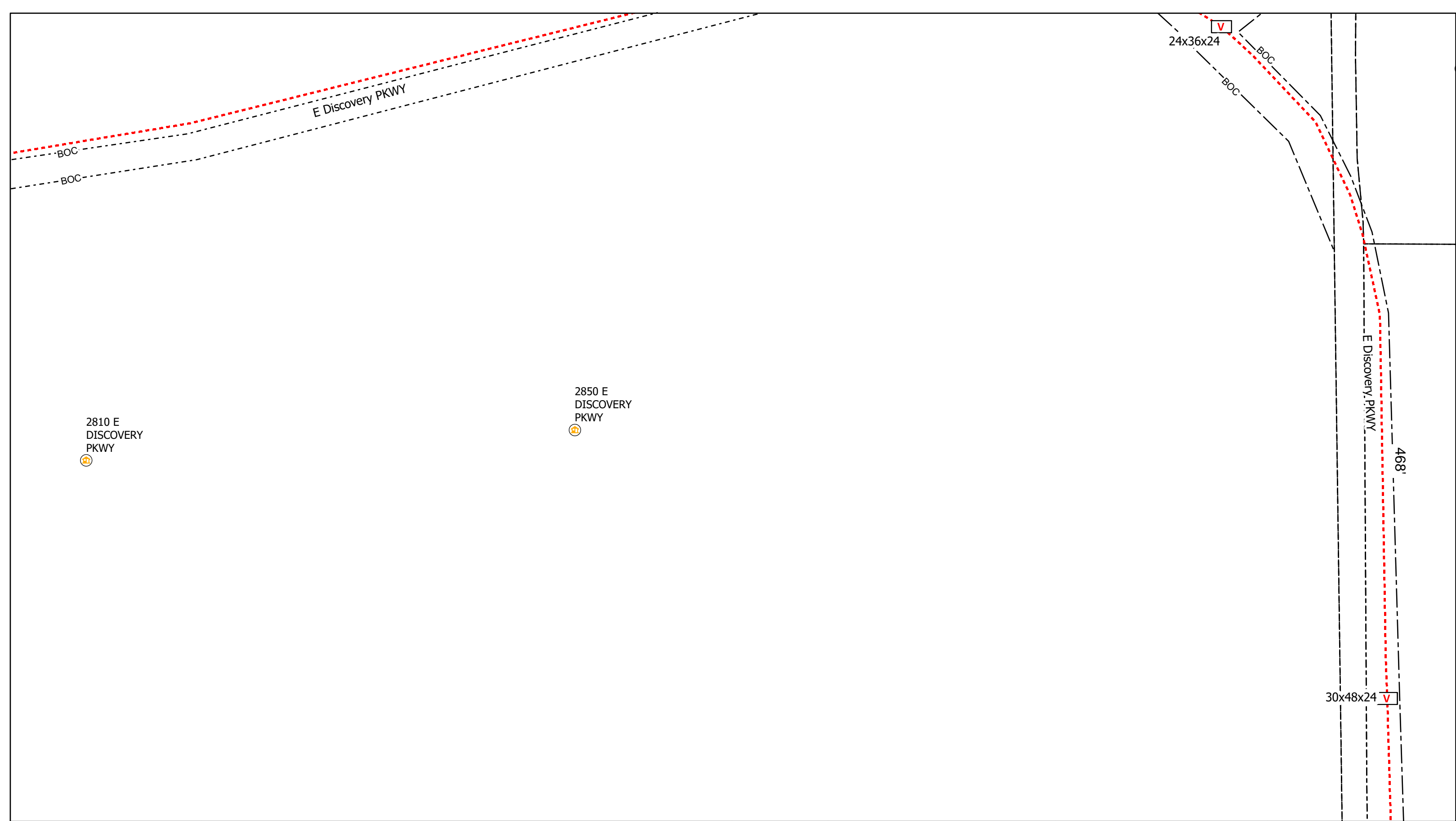

- Legend**
- Vaults
 - Overhead Strand
 - Conduit
 - Bloomington_Parcels
 - Risers
 - Address
 - Anchor
 - Sidewalk

All Flowerpots 12" DIA











City of Bloomington, IN Permit:
Design View

INI	BY	DATE	DESCRIPTION



0 20 40 80 Feet

Legend

-  Vaults
-  Overhead Strand
-  Conduit
-  Bloomington_Parcels
-  Risers
-  Address
-  Anchor
-  Sidewalk

All Flowerpots 12" DIA



Design View

INI	BY	DATE	DESCRIPTION

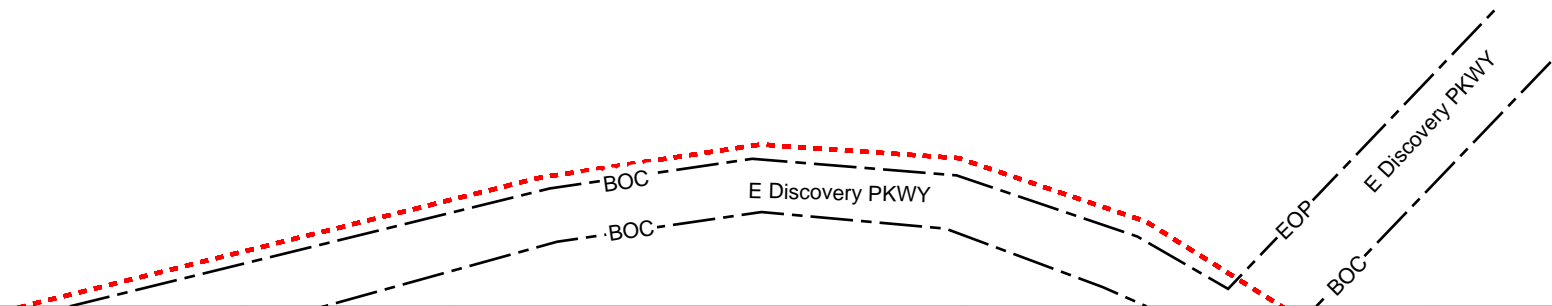

2880 E
DISCOVERY
PKWY

3000 E
DISCOVERY
PKWY

BOC

E Discovery PKWY









ROW

931'



0 20 40 80 Feet

Legend

-  Vaults
-  Overhead Strand
-  Conduit
-  Bloomington_Parcels
-  Risers
-  Address
-  Anchor
-  Sidewalk

All Flowerpots 12" DIA



City of Bloomington, IN Permit:
Design View

INI	BY	DATE	DESCRIPTION



2815 E
10TH ST

3050 E
DISCOVERY
PKWY

E Discovery PKWY

30x48x24 V

E 10th ST

THIS SECTION TO BE
PERMITTED WITH INDOT

2920 E
10TH ST

2820 E
10TH ST

N Pete Ellis DR



0 20 40 80 Feet

Legend

- V Vaults
- Overhead Strand
- - - Conduit
- Bloomington_Parcels
- R Risers
- A Address
- Y Anchor
- └ Sidewalk

All Flowerpots 12" DIA



City of Bloomington, IN Permit:
Design View

INI	BY	DATE	DESCRIPTION



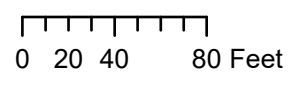
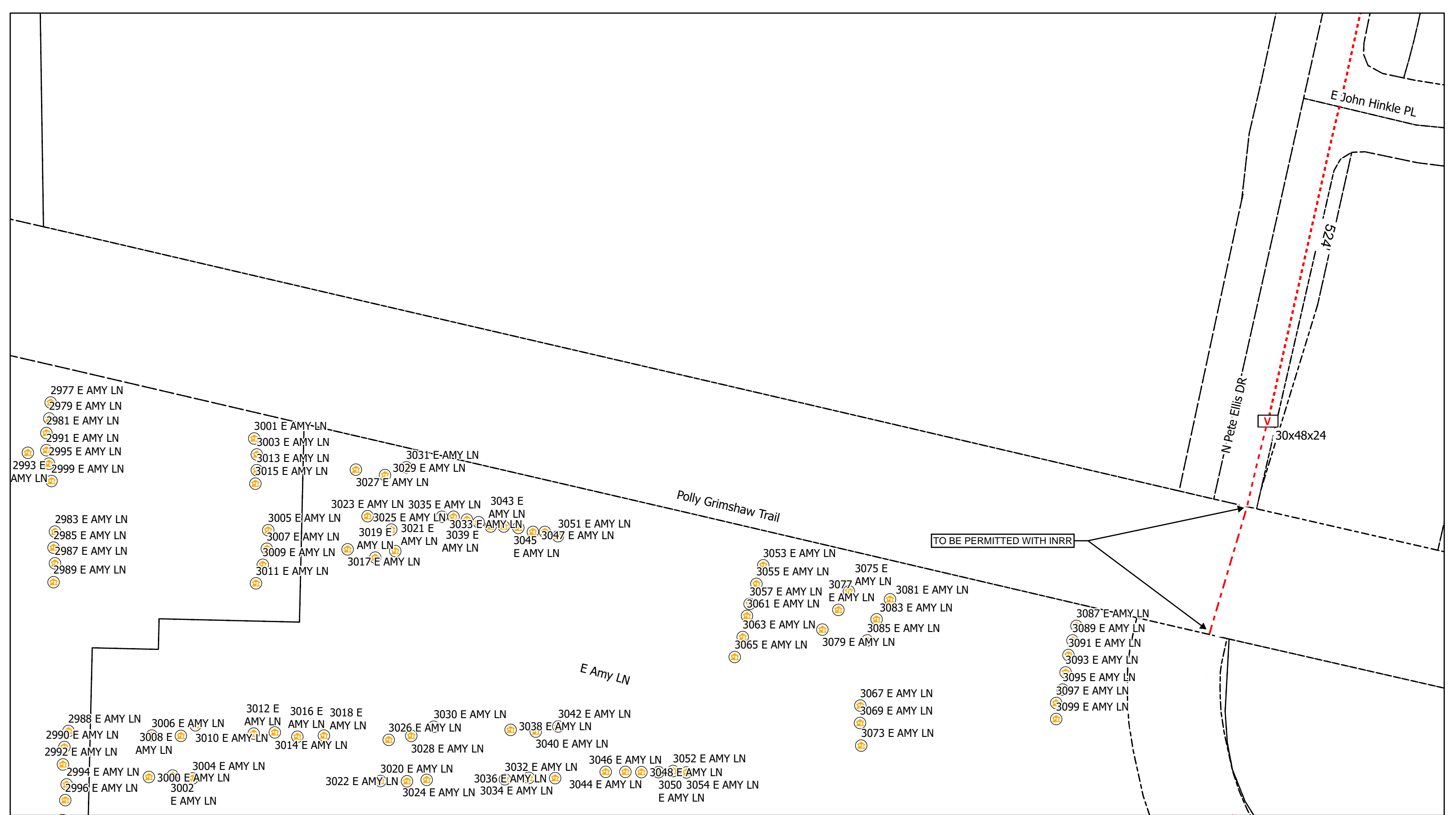

Legend

- Vault
- Overhead Strand
- Conduit
- Bloomington_Parcels
- Riser
- Address
- Anchor
- Sidewalk

All Flowerpots 12" DIA



City of Bloomington, IN Permit:
Design View

INI	BY	DATE	DESCRIPTION



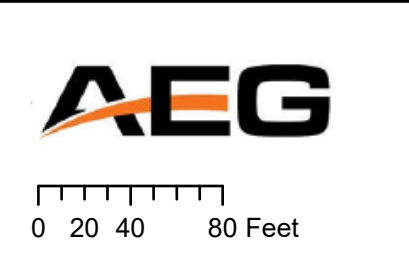
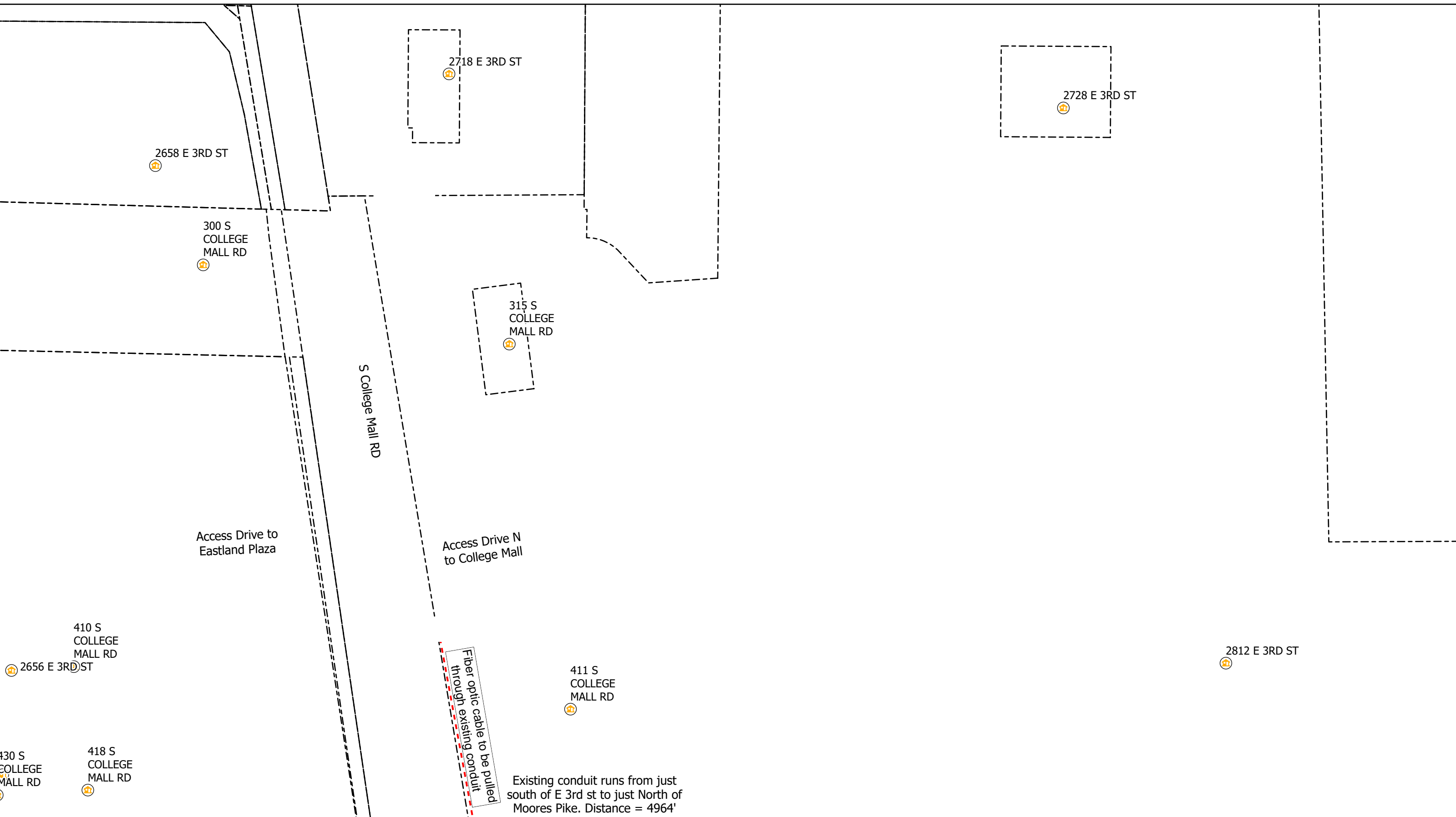

Legend

- Vault
- Overhead Strand
- Conduit
- Bloomington Parcels
- Risers
- Address
- Anchor
- Sidewalk

All Flowerpots 12" DIA

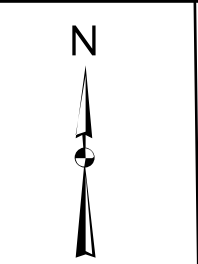

City of Bloomington, IN Permit:
Design View

INI	BY	DATE	DESCRIPTION

Print 8 of 16

2800 E 3RD ST 2898 E 3RD ST

2886 E 3RD ST 2888 E 3RD ST
2890 E 3RD ST 2894 E 3RD ST
3RD ST 2896 E 3RD ST

2808 E 3RD ST
2806 E 3RD ST
2818 E 3RD ST
2810 E 3RD ST
2820 E 3RD ST
2822 E 3RD ST
2824 E 3RD ST
2826 E 3RD ST
2832 E 3RD ST
2828 E 3RD ST
2830 E 3RD ST
2836 E 3RD ST
2834 E 3RD ST
2840 E 3RD ST
2846 E 3RD ST
2842 E 3RD ST
2906 E 3RD ST
2884 E 3RD ST
2802 E 3RD ST
2880 E 3RD ST
2878 E 3RD ST
2874 E 3RD ST
2870 E 3RD ST
2872 E 3RD ST
2868 1/2 E 3RD ST
2864 E 3RD ST
2860 E 3RD ST
2936 E 3RD ST
2862 E 3RD ST
2940 E 3RD ST
2848 E 3RD ST
2854 E 3RD ST

Fiber optic cable to be pulled through existing conduit

S College Mall RD

2nd ST

510 S COLLEGE MALL RD

512 S COLLEGE MALL RD

530 S COLLEGE MALL RD

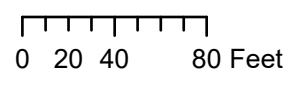

Legend

- Vault
- Overhead Strand
- Conduit
- Bloomington_Parcels
- Risers
- Address
- Anchor
- Sidewalk

All Flowerpots 12" DIA



City of Bloomington, IN Permit:
Design View

INI	BY	DATE	DESCRIPTION



2660 E 2ND ST
 2656 E 2ND ST
 2664 E 2ND ST
 2666 E 2ND ST
 2668 E 2ND ST
 2674 E 2ND ST
 2676 E 2ND ST

608 S COLLEGE MALL RD

616-S COLLEGE MALL RD

S College Mall RD

Fiber optic cable to be pulled through existing conduit

721 S COLLEGE MALL RD

2852 E 3RD ST
 2844 E 3RD ST









2850 E 3RD ST

741 S COLLEGE MALL RD
 731 S COLLEGE MALL RD



0 20 40 80 Feet

Legend

-  Vaults
-  Overhead Strand
-  Conduit
-  Bloomington_Parcels
-  Risers
-  Address
-  Anchor
-  Sidewalk

All Flowerpots 12" DIA



City of Bloomington, IN Permit:
 Design View

INI	BY	DATE	DESCRIPTION



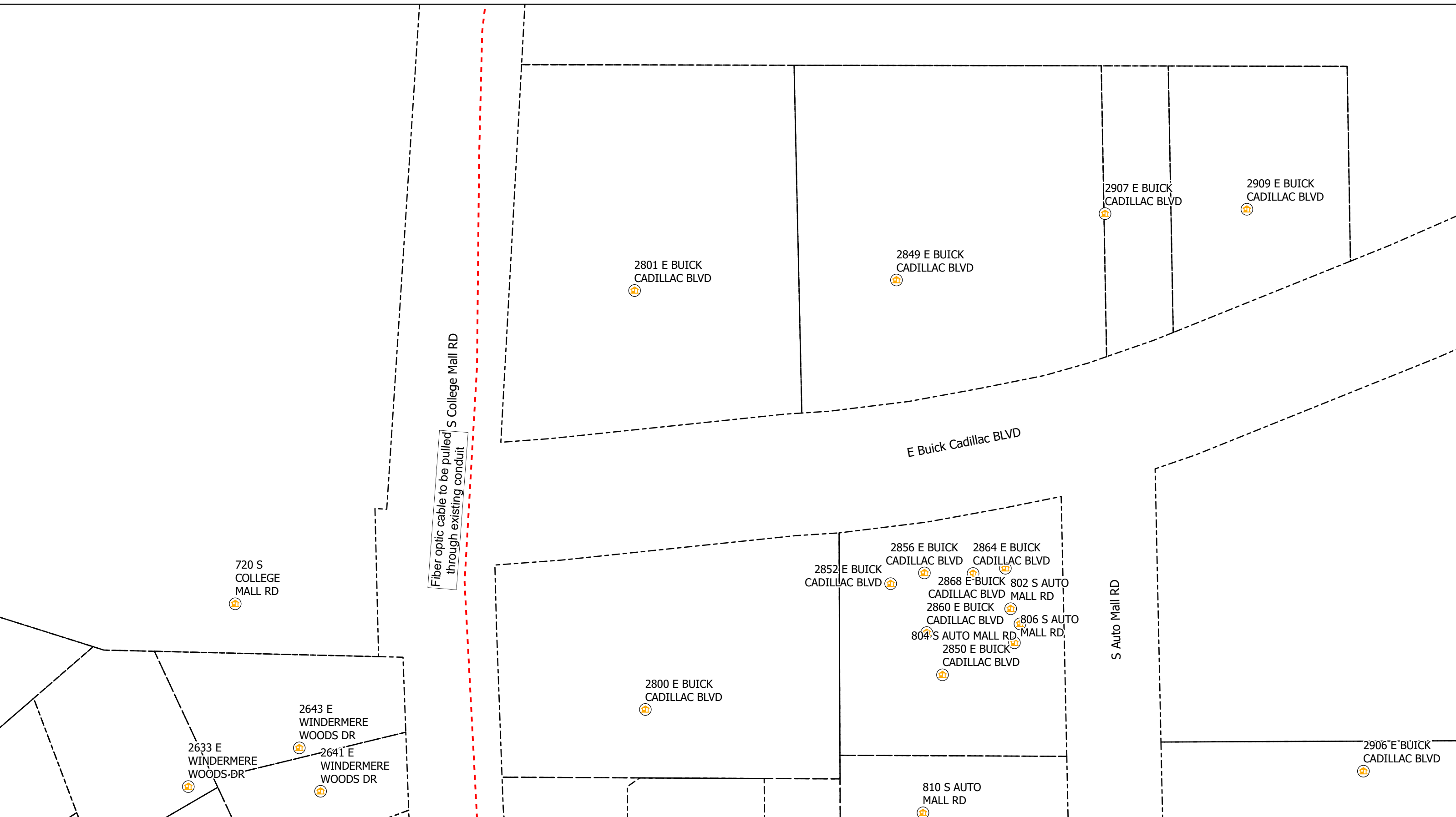

AEG

0 20 40 80 Feet

Legend

- Vault
- Overhead Strand
- Conduit
- Bloomington_Parcels
- Risers
- Address
- Anchor
- Sidewalk

All Flowerpots 12" DIA

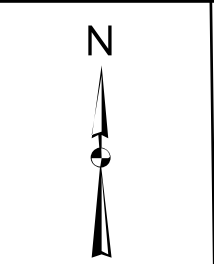







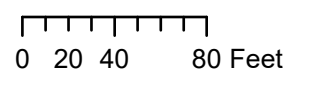
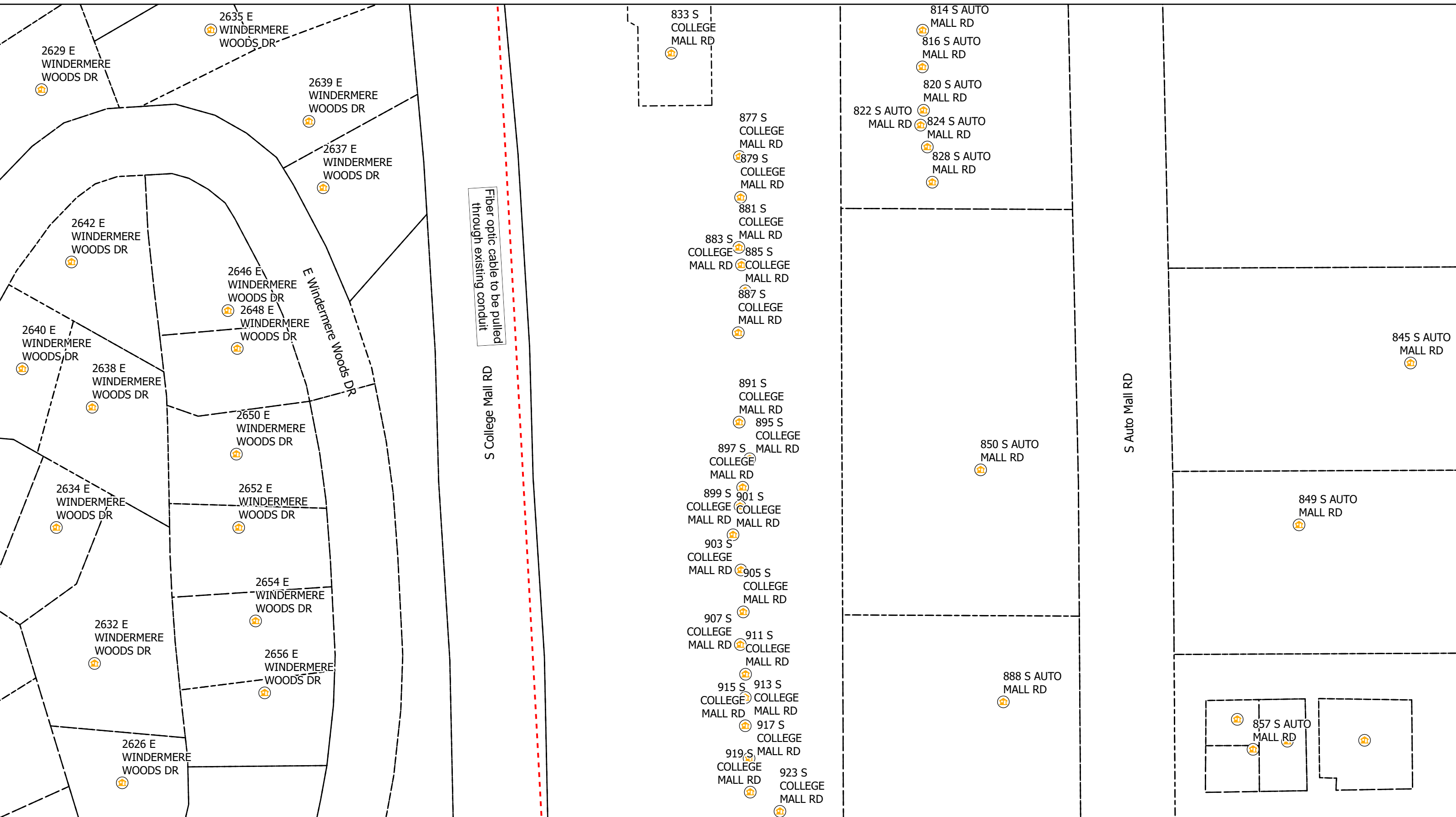

City of Bloomington, IN Permit:
Design View

INI	BY	DATE	DESCRIPTION

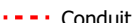
Print 11 of 16



Legend

-  Vaults
-  Overhead Strand
-  Conduit
-  Bloomington_Parcels
-  Risers
-  Address
-  Anchor
-  Sidewalk

All Flowerpots 12" DIA







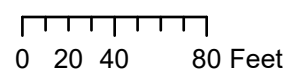
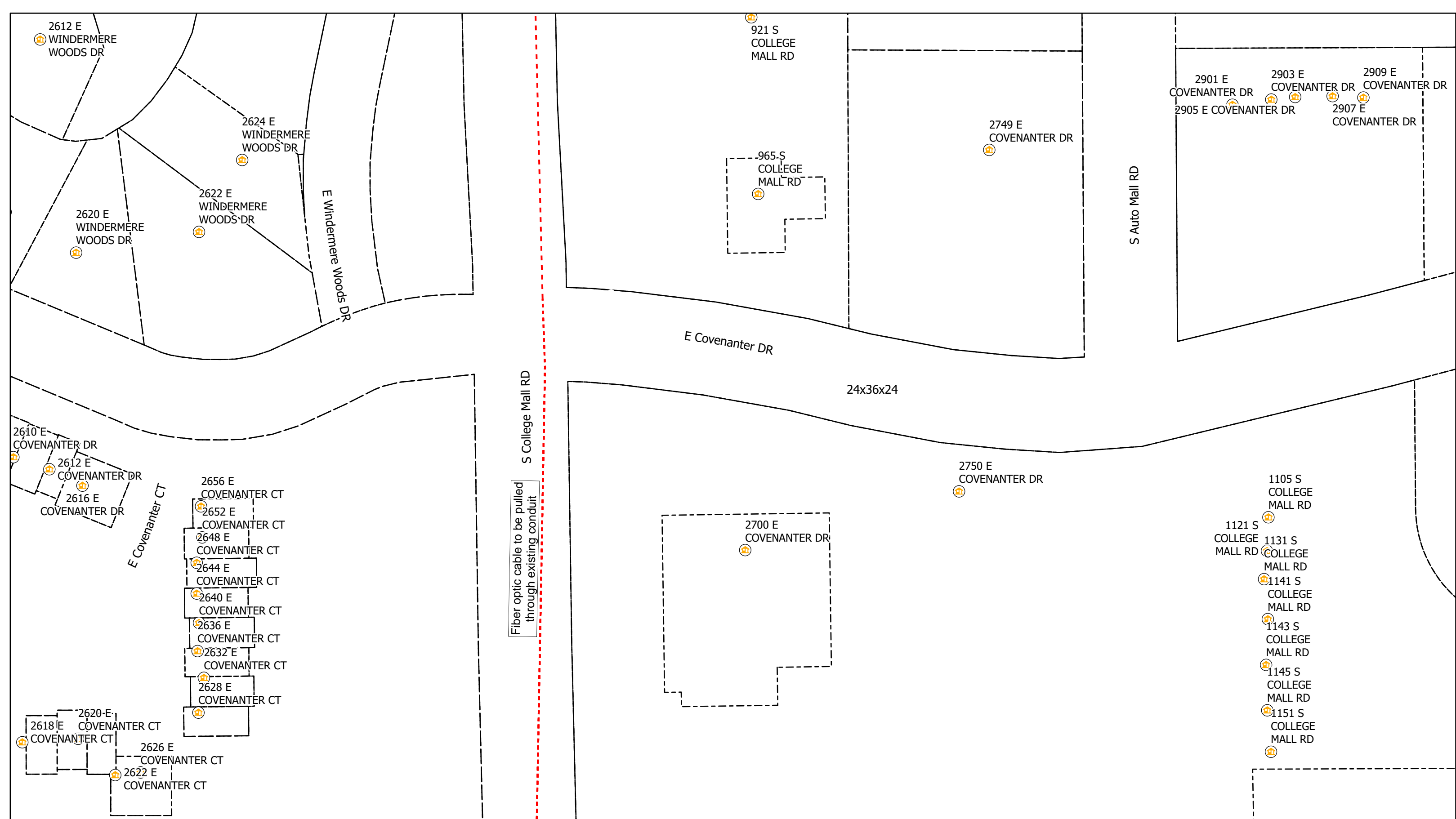

City of Bloomington, IN Permit:
Design View

INI	BY	DATE	DESCRIPTION





Legend

-  Vaults
-  Overhead Strand
-  Conduit
-  Bloomington_Parcels
-  Risers
-  Address
-  Anchor

 Sidewalk

All Flowerpots 12" DIA



City of Bloomington, IN Permit:
Design View

INI	BY	DATE	DESCRIPTION



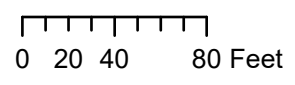
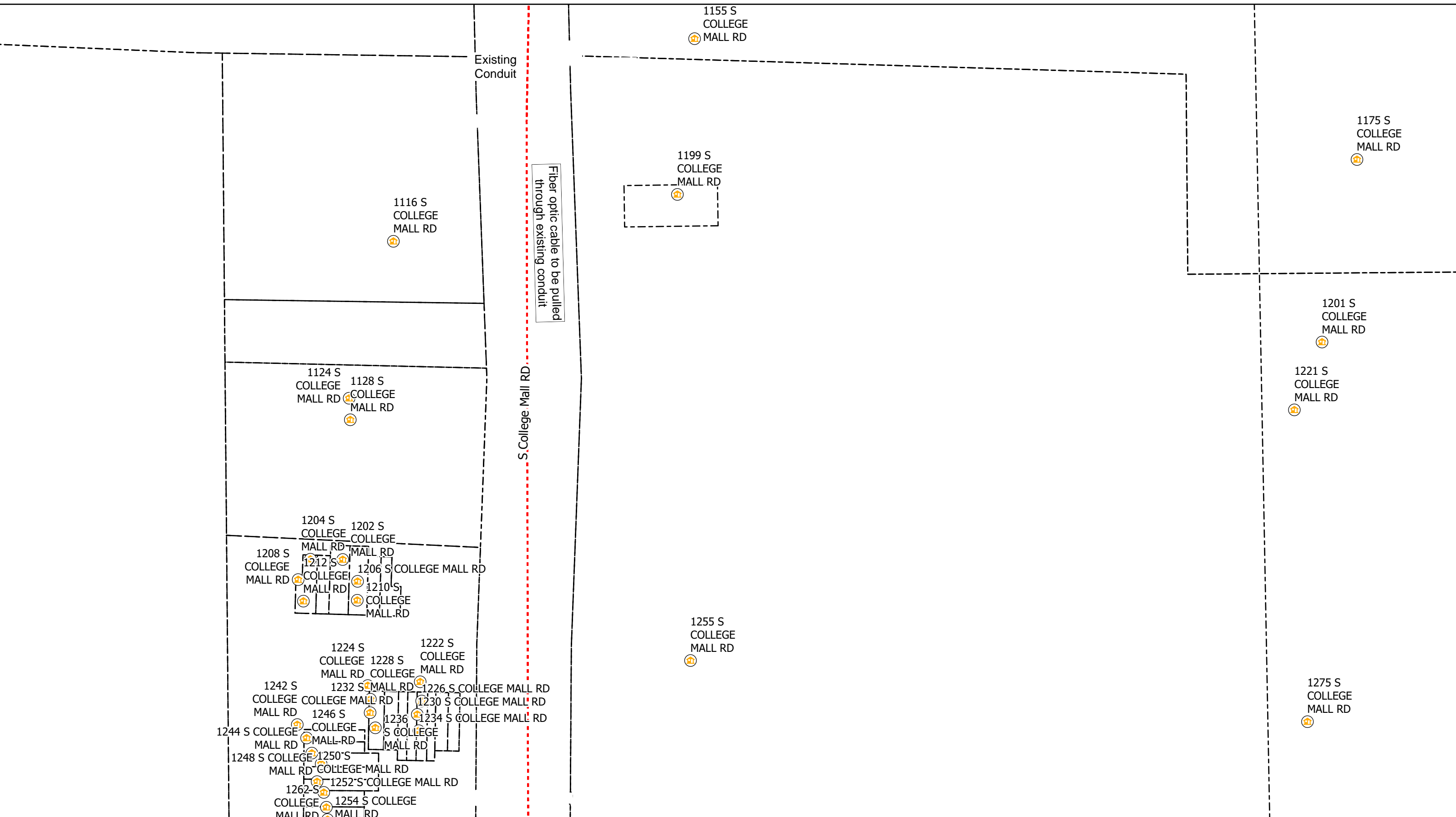

Legend

- Vault
- Overhead Strand
- Conduit
- Bloomington_Parcels
- Risers
- Address
- Anchor
- Sidewalk

All Flowerpots 12" DIA



City of Bloomington, IN Permit:
Design View

INI	BY	DATE	DESCRIPTION



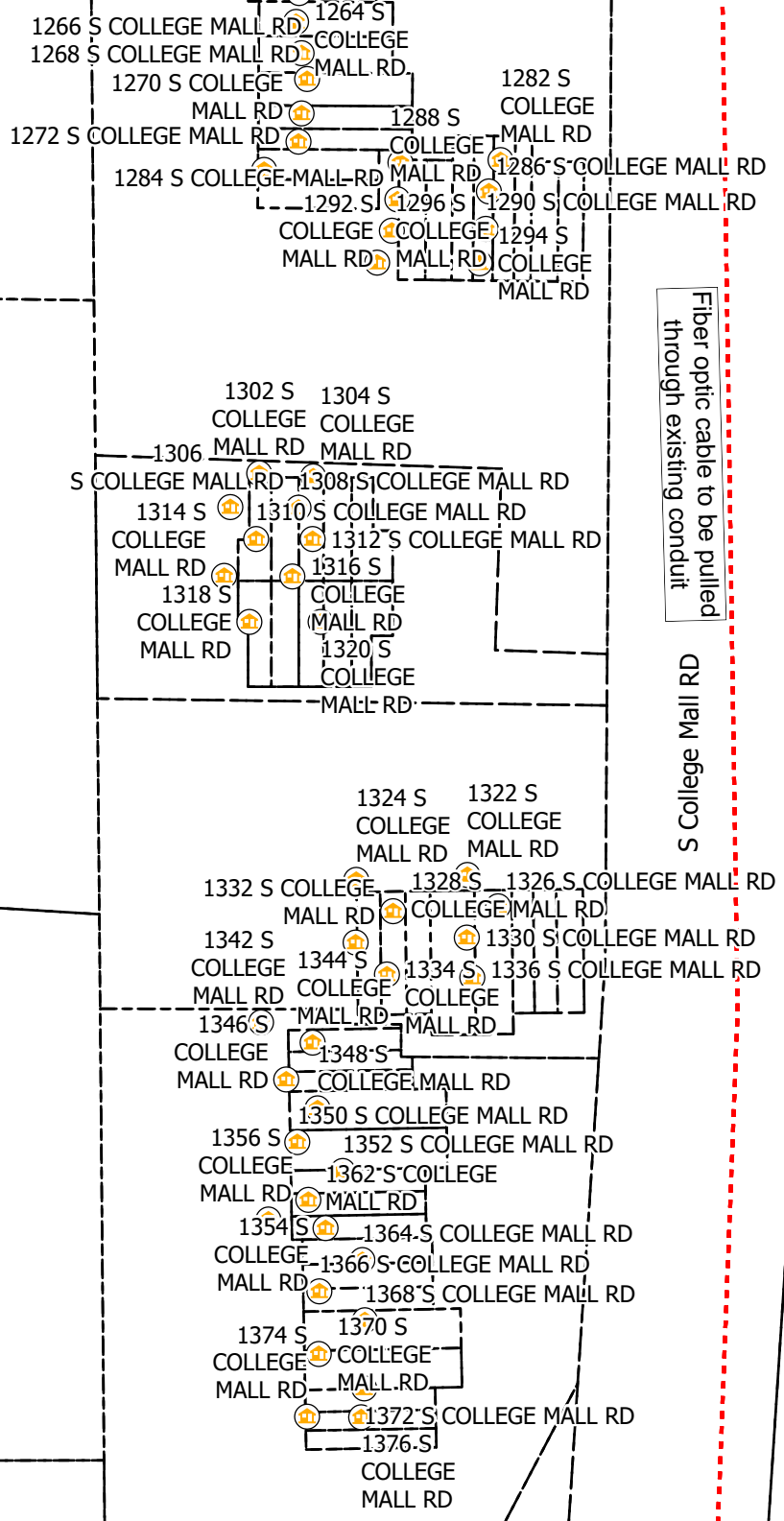

Fiber optic cable to be pulled through existing conduit

S College Mall Rd

1285 S COLLEGE MALL RD

1301 S COLLEGE MALL RD
1305 S COLLEGE MALL RD
1311 S COLLEGE MALL RD
1315 S COLLEGE MALL RD
1321 S COLLEGE MALL RD

1351 S COLLEGE MALL RD

1411 S SARE RD

1419 S SARE RD

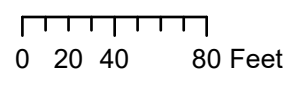

Legend

- Vaults
- Overhead Strand
- Conduit
- Bloomington_Parcels
- Risers
- Address
- Y Anchor
- ⌞ Sidewalk

All Flowerpots 12" DIA





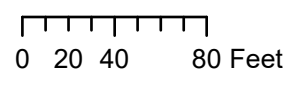
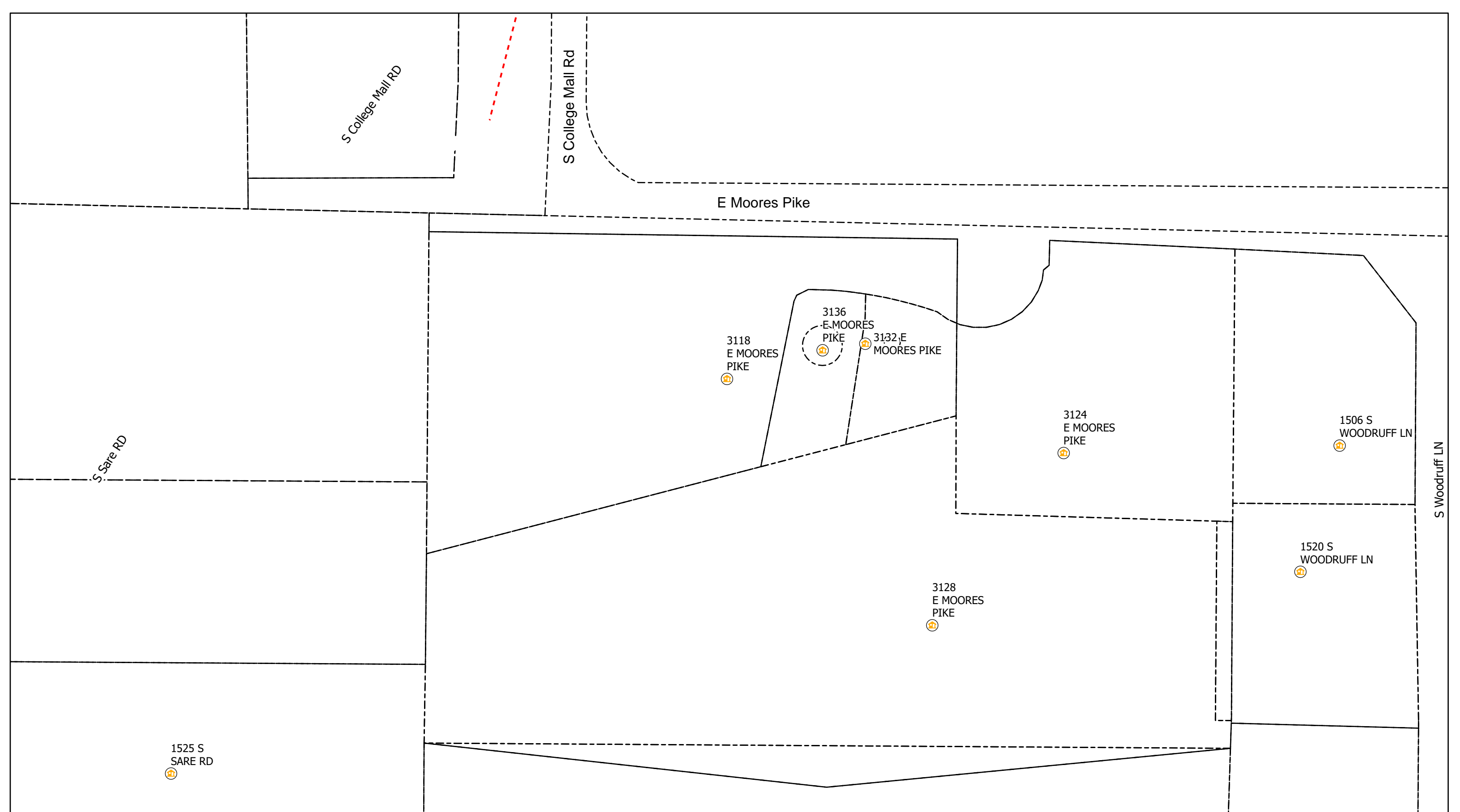

City of Bloomington, IN Permit:
Design View

INI	BY	DATE	DESCRIPTION





Legend

-  Vaults
-  Overhead Strand
-  Conduit
-  Bloomington_Parcels
-  Risers
-  Address
-  Anchor



All Flowerpots 12" DIA



City of Bloomington, IN Permit:
Design View

INI	BY	DATE	DESCRIPTION



CONCEPTUAL SIDE VIEW

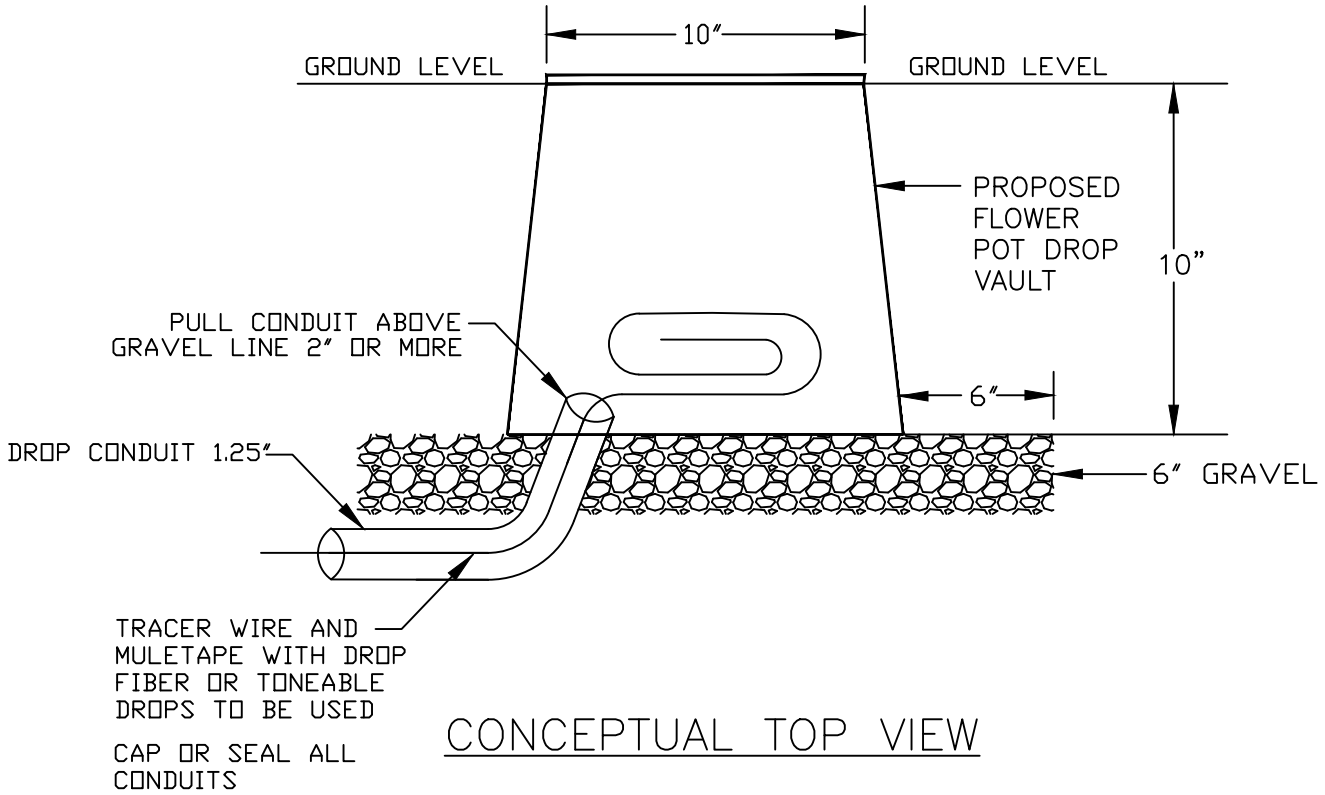

CONCEPTUAL TOP VIEW

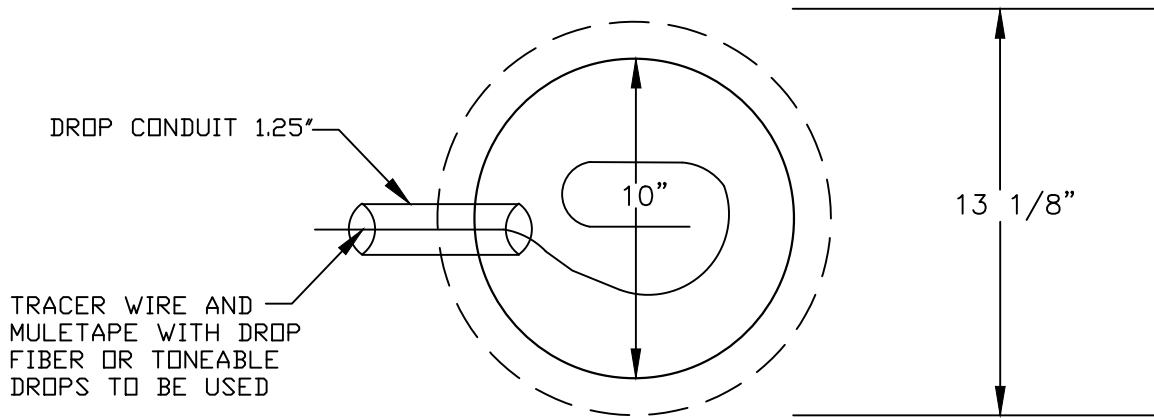

FLOWER POT

30"x48" PC UNIT, 2PC TIER 15/22
 18", 24", and 36" HEIGHT



AMERICAN POLYMER COMPANY

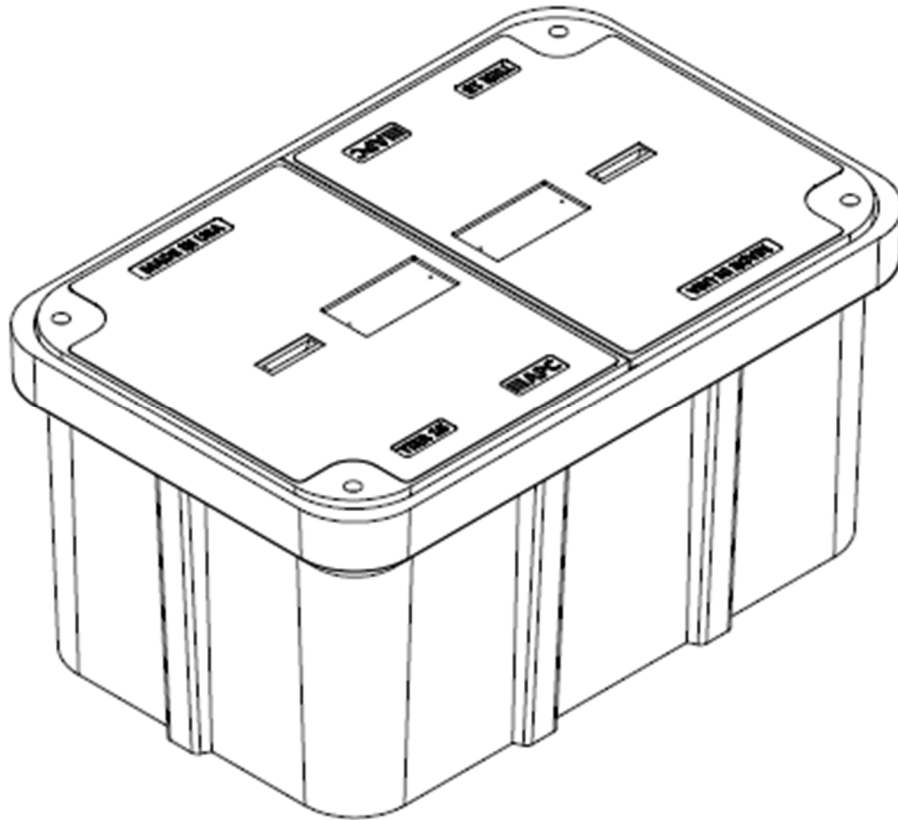

Description	Nominal Size	ANSI Tier	Part Number	Estimated Weight
PC Unit – TIER 15	30"x48"x18"	Tier 15	P304818HU15...	460 lbs.
PC Unit – TIER 22	30"x48"x18"	Tier 22	P304818HU22...	525 lbs.
PC Unit – TIER 15	30"x48"x24"	Tier 15	P304824HU15...	510 lbs.
PC Unit – TIER 22	30"x48"x24"	Tier 22	P304824HU22...	575 lbs.
PC Unit – TIER 15	30"x48"x36"	Tier 15	P304836HU15...	615 lbs.
PC Unit – TIER 22	30"x48"x36"	Tier 22	P304836HU22...	680 lbs.



30"x48" PC UNIT, 2PC TIER 15/22

18", 24", and 36" HEIGHT



AMERICAN POLYMER COMPANY

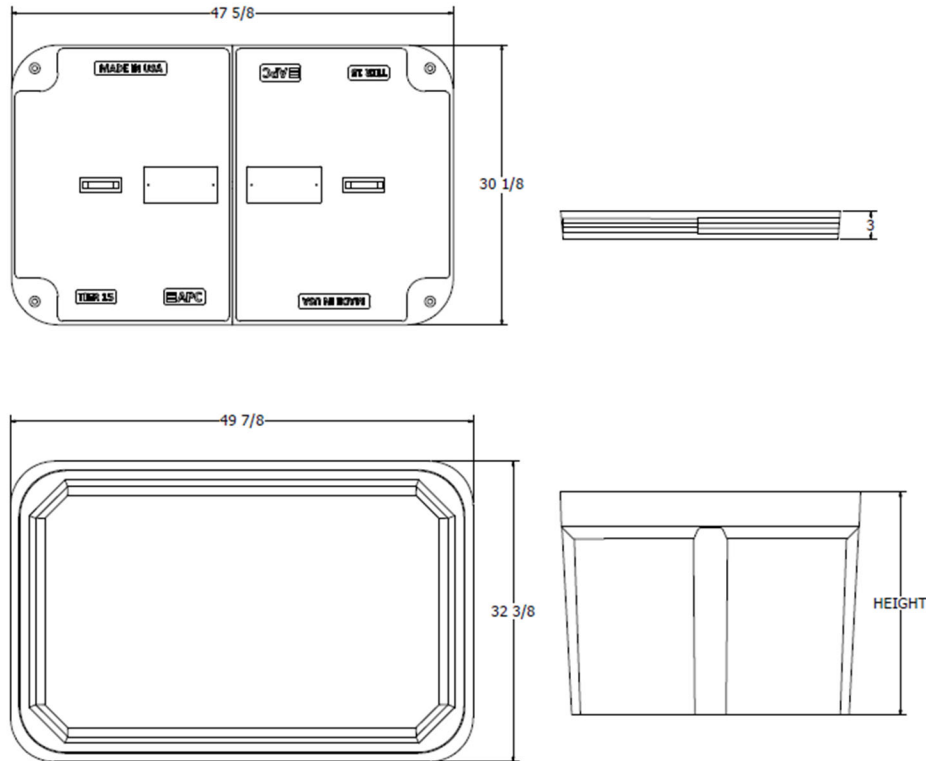

Components	Nominal Size	ANSI Tier	Part Number	Estimated Weight
Replacement Box	30"x48"x18"	Tier 22	P304818B22	185 lbs.
Replacement Box	30"x48"x24"	Tier 22	P304824B22	235 lbs.
Replacement Box	30"x48"x36"	Tier 22	P304836B22	340 lbs.
Replacement Lids - T15	30"x48" (half)	Tier 15	Various	150 lbs.
Replacement Lids - T22	30"x48" (half)	Tier 22	Various	170 lbs.

Bolt options



Machine Thread



Auger Thread



24"x36" PC UNIT, TIER 15/22
 18", 24", 30", and 36" HEIGHT



AMERICAN POLYMER COMPANY

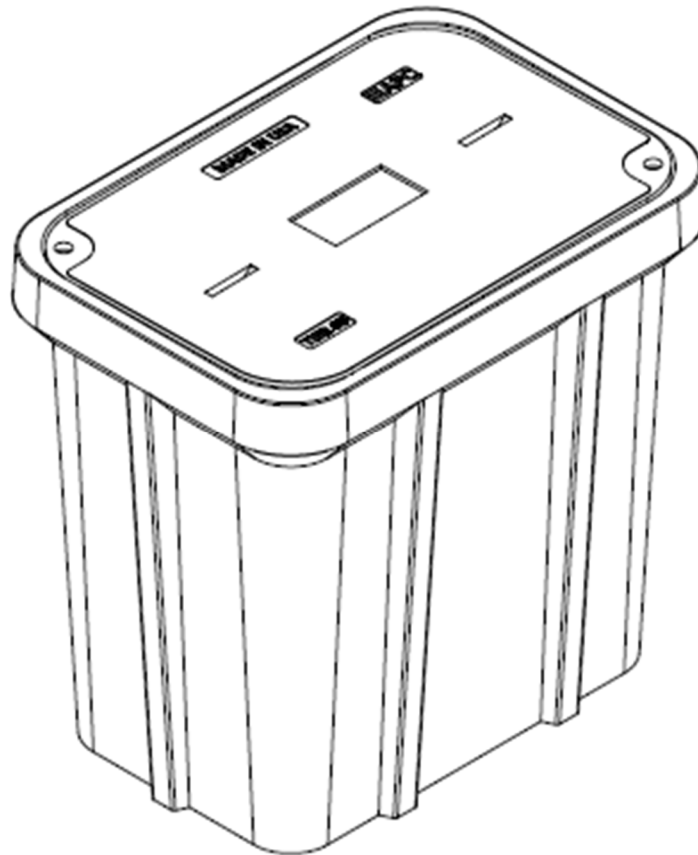

Description	Nominal Size	ANSI Tier	Part Number	Estimated Weight
PC Unit – TIER 15	24x36"x18"	Tier 15	P243618U15...	335 lbs.
PC Unit – TIER 22	24x36"x18"	Tier 22	P243618U22...	355 lbs.
PC Unit – TIER 15	24x36"x24"	Tier 15	P243624U15...	365 lbs.
PC Unit – TIER 22	24x36"x24"	Tier 22	P243624U22...	385 lbs.
PC Unit – TIER 15	24x36"x30"	Tier 15	P243630U15...	395 lbs.
PC Unit – TIER 22	24x36"x30"	Tier 22	P243630U22...	415 lbs.
PC Unit – TIER 15	24x36"x36"	Tier 15	P243636U15...	425 lbs.
PC Unit – TIER 22	24x36"x36"	Tier 22	P243636U22...	445 lbs.



24"x36" PC UNIT, TIER 15/22

18", 24", 30", and 36" HEIGHT



AMERICAN POLYMER COMPANY

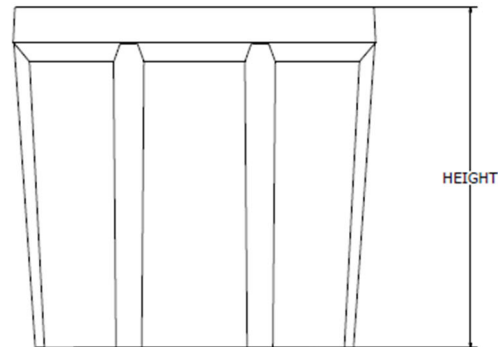
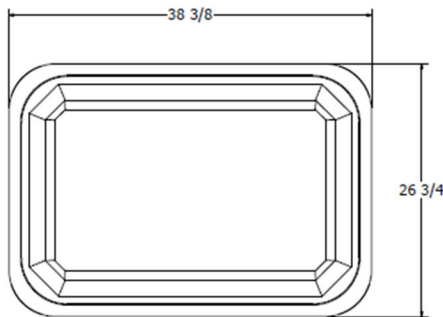
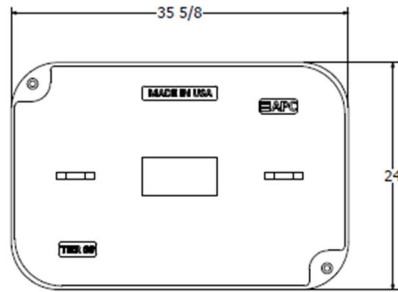

Components	Nominal Size	ANSI Tier	Part Number	Estimated Weight
Replacement Box	24"x36"x18"	Tier 22	P243618B22	165 lbs.
Replacement Box	24"x36"x24"	Tier 22	P243624B22	195 lbs.
Replacement Box	24"x36"x30"	Tier 22	P243630B22	225 lbs.
Replacement Box	24"x36"x36"	Tier 22	P243636B22	255 lbs.
Replacement Lids - T15	24"x36"	Tier 15	Various	170 lbs.
Replacement Lids - T22	24"x36"	Tier 22	Various	190 lbs.

Bolt options

Hex Head



Machine Thread



Penta Head



Auger Thread



17"x30" PC UNIT, TIER 15/22

12", 18", 24", and 30" HEIGHT



AMERICAN POLYMER COMPANY

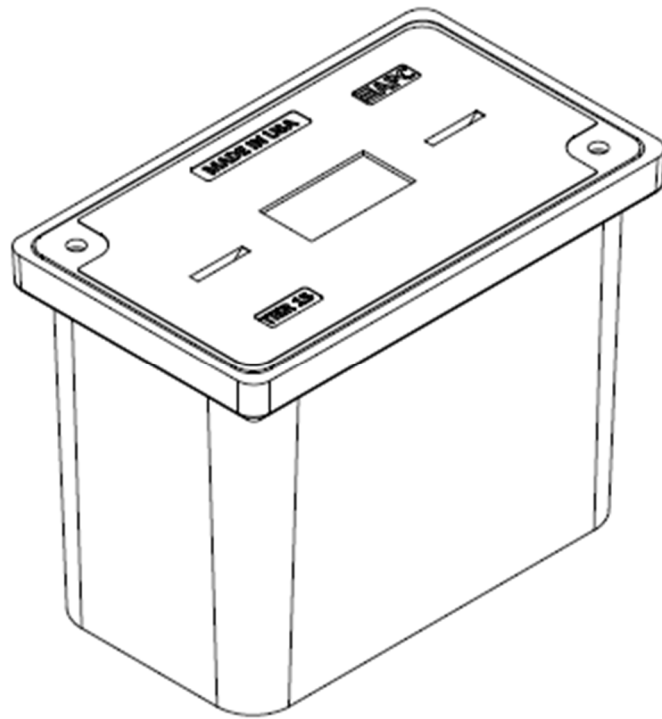

Description	Nominal Size	ANSI Tier	Part Number	Estimated Weight
PC Unit – TIER 15	17"x30"x12"	Tier 15	P173012U15...	138 lbs.
PC Unit – TIER 22	17"x30"x12"	Tier 22	P173012U22...	147 lbs.
PC Unit – TIER 15	17"x30"x18"	Tier 15	P173018U15...	172 lbs.
PC Unit – TIER 22	17"x30"x18"	Tier 22	P173018U22...	181 lbs.
PC Unit – TIER 15	17"x30"x24"	Tier 15	P173024U15...	192 lbs.
PC Unit – TIER 22	17"x30"x24"	Tier 22	P173024U22...	201 lbs.
PC Unit – TIER 15	17"x30"x30"	Tier 15	P173030U15...	217 lbs.
PC Unit – TIER 22	17"x30"x30"	Tier 22	P173030U22...	226 lbs.



17"x30" PC UNIT, TIER 15/22

12", 18", 24", and 30" HEIGHT



AMERICAN POLYMER COMPANY

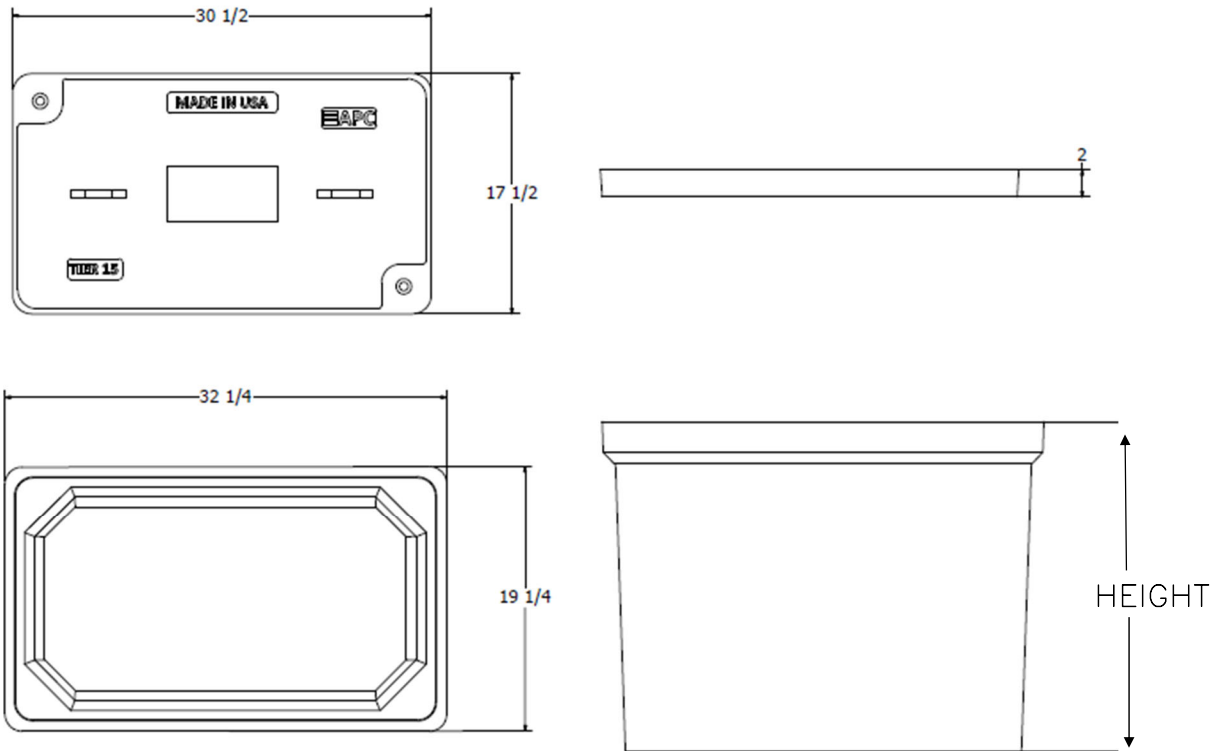

Components	Nominal Size	ANSI Tier	Part Number	Estimated Weight
Replacement Box	17"x30"x12"	Tier 22	P173012B22	66 lbs.
Replacement Box	17"x30"x18"	Tier 22	P173018B22	100 lbs.
Replacement Box	17"x30"x24"	Tier 22	P173024B22	120 lbs.
Replacement Box	17"x30"x30"	Tier 22	P173030B22	145 lbs.
Replacement Lids – T15	17"x30"	Tier 15	Various	72 lbs.
Replacement Lids – T22	17"x30"	Tier 22	Various	81 lbs.

Bolt options



Machine Thread



Auger Thread



33"x60" PC UNIT, 2PC TIER 15/22
36" HEIGHT



AMERICAN POLYMER COMPANY

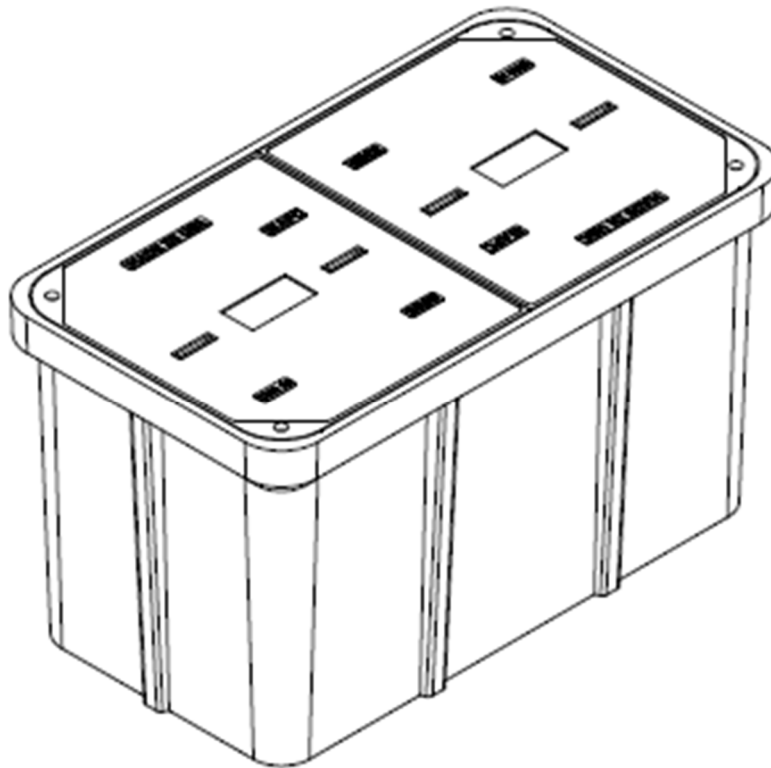

Description	Nominal Size	ANSI Tier	Part Number	Estimated Weight
PC Unit - TIER 15	33"x60"x36"	Tier 15	P336036U15...	930 lbs.
PC Unit - TIER 22	33"x60"x36"	Tier 22	P336036U22...	1030 lbs.



33"x60" PC UNIT, 2PC TIER 15/22

36" HEIGHT



AMERICAN POLYMER COMPANY

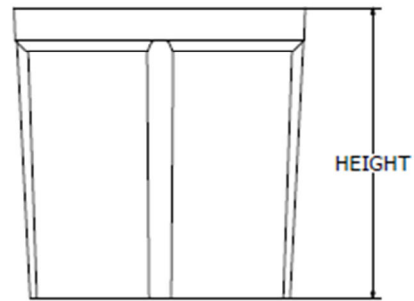
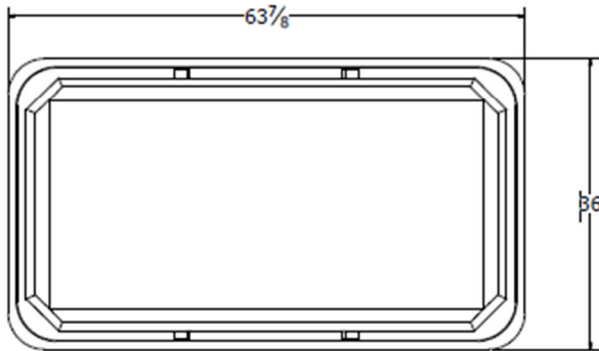
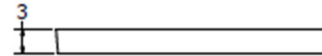
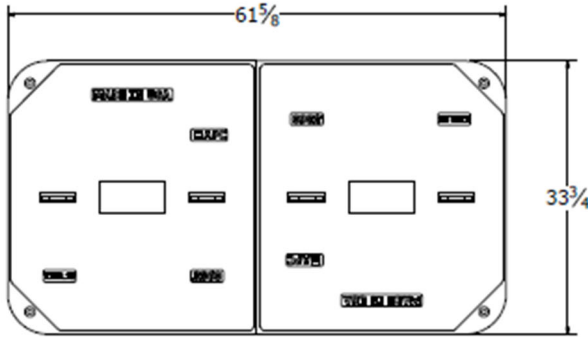

Components	Nominal Size	ANSI Tier	Part Number	Estimated Weight
Replacement Box	33"x60"x36"	Tier 22	P336036B22	530 lbs.
Replacement Lids - T15	33"x60" (half)	Tier 15	Various	200 lbs.
Replacement Lids - T22	33"x60" (half)	Tier 22	Various	250 lbs.

Bolt options

Hex Head



Machine Thread



Penta Head



Auger Thread



Spacing Charts Based on MUTCD			Must be Approved by an Engineer				
Speed (MPH) Prior To Road Work	SIGN SPACING, FT.		BUFFER SPACE, FT.	TAPER LENGTH, FT.		CHANNELIZING SPACING, FT.	
	Non-Divided Highways	Divided Highways	Length	Shoulder (10 ft. Width)	Lane (12 ft. Width)	Through Taper	Through Buffer/Work Area
0-35	200	200	250	70	245	35	50
40-45	350	500	360	150	540	40	80
50-55	500	1000	495	185	660	50	100
60-70	SA-1000, SB-1500, SC-2640		730	235	840	60	120
Urban Low Speed - 100 FT							

APPROVED/ACCEPTED BY:
ENGINEER, OWNER, or PRIME CONTRACTOR
 Check for Notice to Proceed.
BLC01a-F1 FeederRoute TCP1

Signature: _____

Company: _____



Date: 10/17/2022 Project: BLC01a-F1 FeederRoute TCP1 :
Traffic Control Suggestion For: AEG :
By: Road Runner Safety Services, Inc. : Nathan

Comments:
Drawing not to scale. Traffic control plan must be approved by an engineer. This is a suggestion only. Road Runners Safety Services, Inc. has no liability for this suggested traffic control plan. Actual placement and spacing of all traffic control devices will depend on field conditions and must conform to MUTCD standards.

- Legend**
- Channelizer
 - Conduit
 - Flagger (Person)
 - Vault
 - Work Area

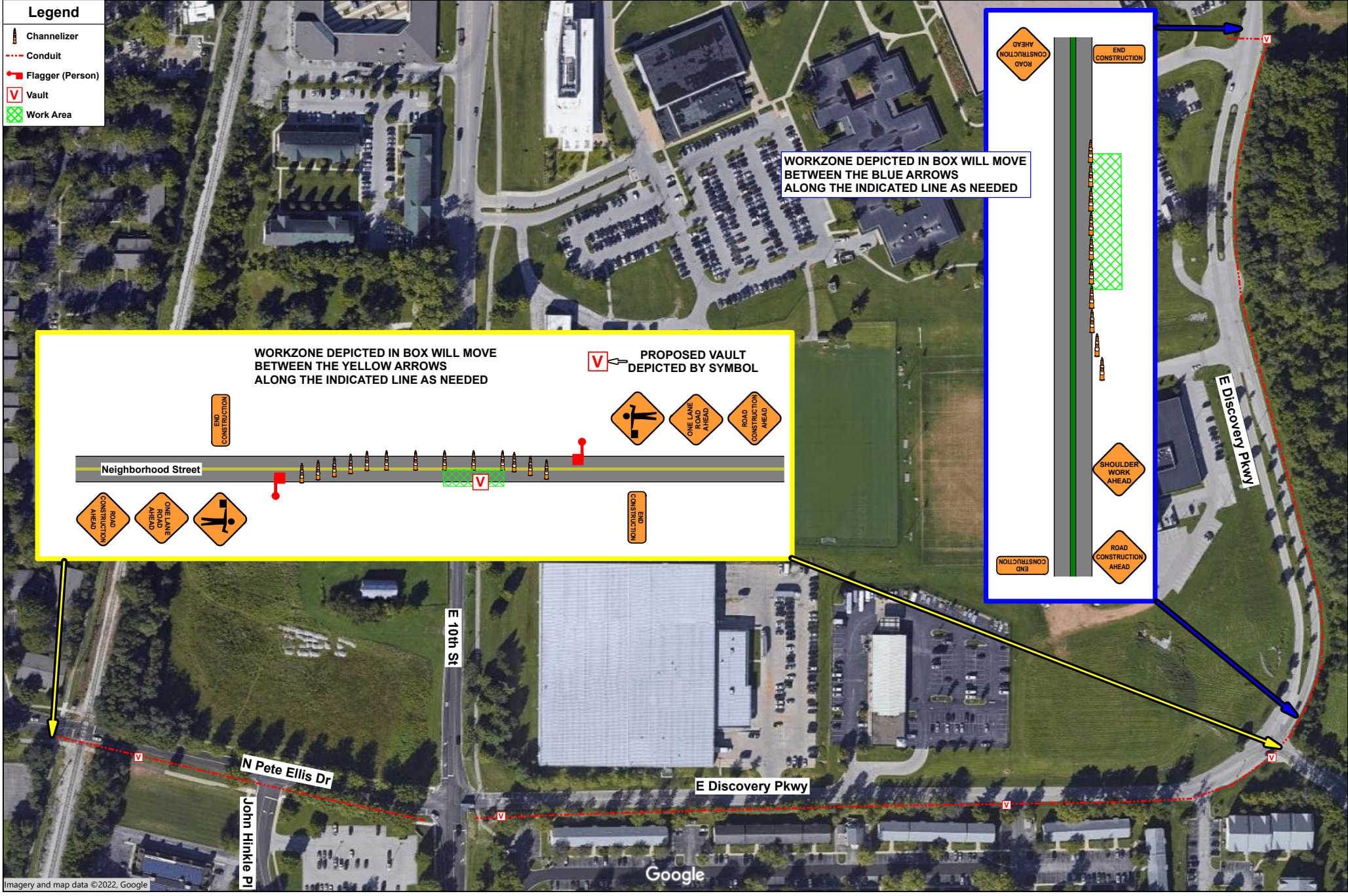

Spacing Charts Based on MUTCD			Must be Approved by an Engineer				
Speed (MPH) Prior To Road Work	SIGN SPACING, FT.		BUFFER SPACE, FT.	TAPER LENGTH, FT.	CHANNELIZING SPACING, FT.		
	Non-Divided Highways	Divided Highways	Length	Shoulder (10 ft. Width)	Lane (12 ft. Width)	Through Taper	Through Buffer/Work Area
0-35	200	200	250	70	245	35	50
40-45	350	500	360	150	540	40	80
50-55	500	1000	495	185	660	50	100
60-70	SA-1000, SB-1500, SC-2640		730	235	840	60	120
Urban Low Speed - 100 FT							

APPROVED/ACCEPTED BY:
ENGINEER, OWNER, or PRIME CONTRACTOR
 Check for Notice to Proceed.
BLC01a-F1 FeederRoute TCP2

Signature: _____

Company: _____

Road Runner Safety Services, Inc.

Date: 10/17/2022 Project: BLC01a-F1 FeederRoute TCP2 :
: Traffic Control Suggestion For: AEG :
By: Road Runner Safety Services, Inc. : Nathan

Comments:
Drawing not to scale. Traffic control plan must be approved by an engineer. This is a suggestion only. Road Runners Safety Services, Inc. has no liability for this suggested traffic control plan. Actual placement and spacing of all traffic control devices will depend on field conditions and must conform to MUTCD standards.

- Legend**
- Arrow Board
 - Channelizer
 - Existing Conduit
 - Work Area

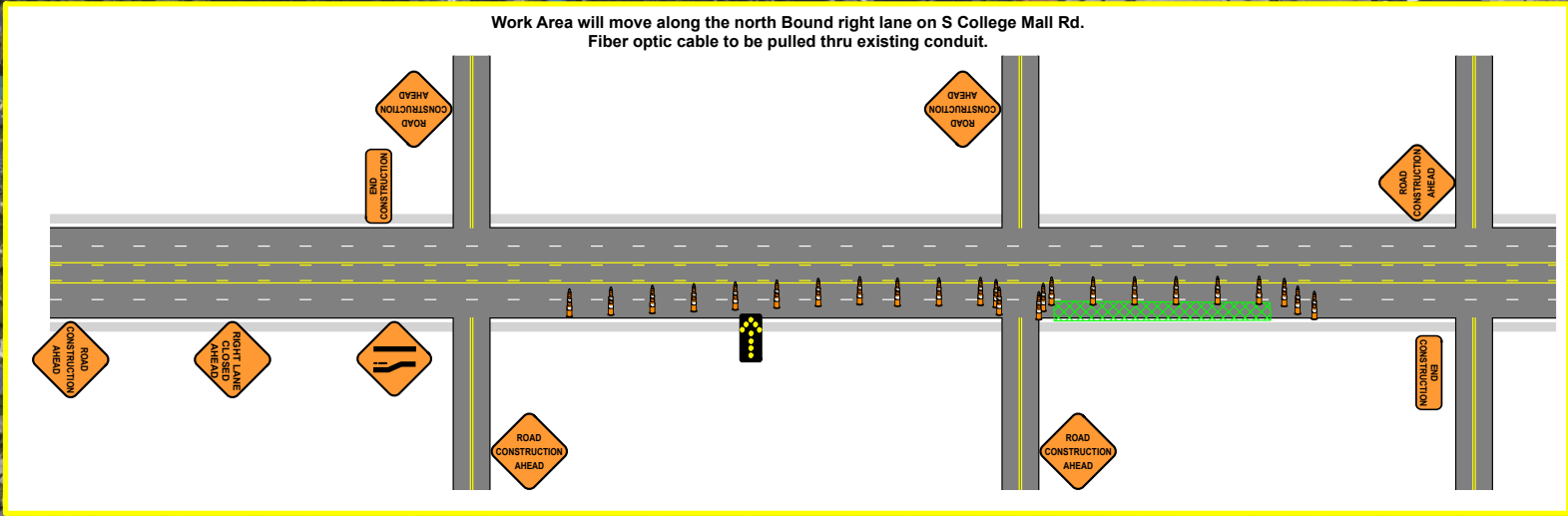
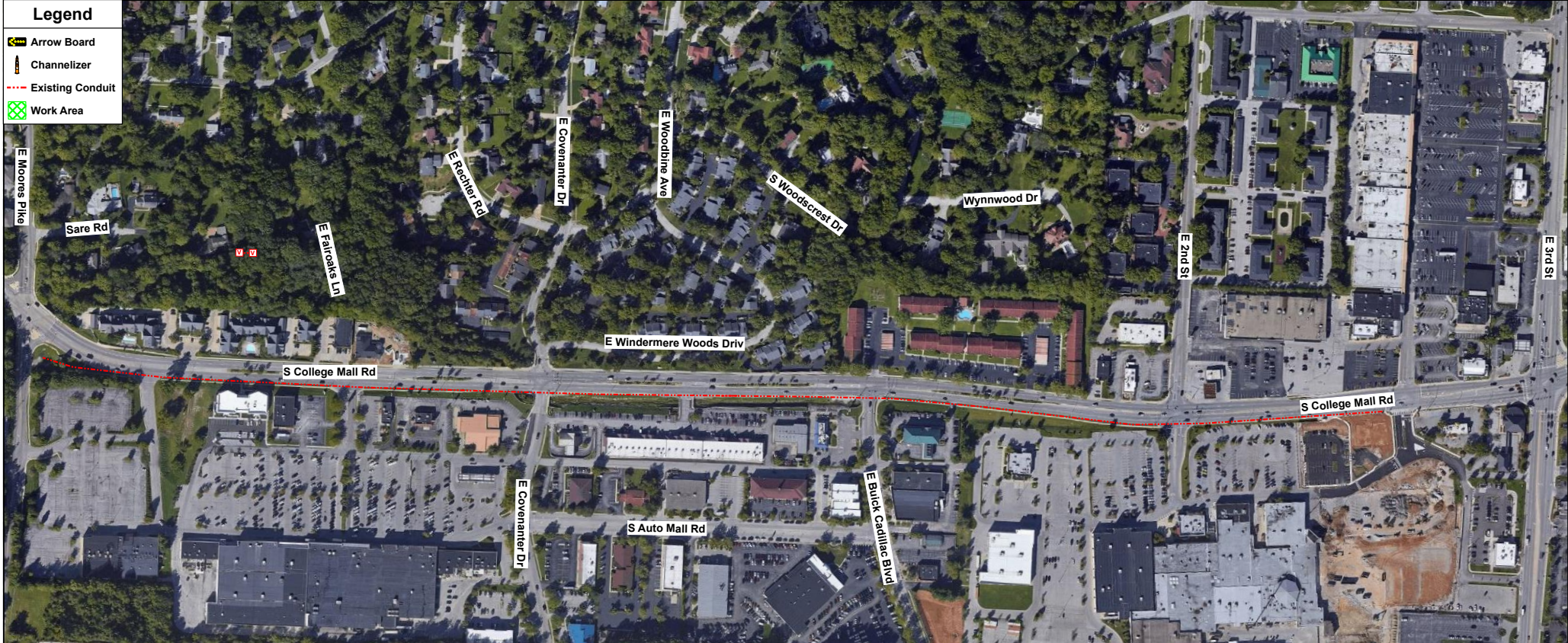



Board of Public Works Staff Report

Project/Event: Change Order #1 to Contract with Strauser Construction Co., Inc.
for Lower Level Renovation at Fire Station #2

Petitioner/Representative: J.D. Boruff, Public Works

Staff Representative: J.D. Boruff

Meeting Date: October 25, 2022

The contractor and Fire Department staff identified a change they deem necessary to the scope of work for the Lower Level Renovation at Fire Station #2. This request is to change the requirement the originally specified wooden window in the south wall of the project are to an aluminum frame window. This request includes all additional material and labor costs to complete this change.

The original contract with Strauser Construction was for \$91,800.00. This change order will add up to a net increase of the contract not to exceed amount of \$1,690.00. This will result in a new contract amount of \$93,490.00. This would represent a 1.8% increase in the contract amount.

Respectfully Submitted,

A handwritten signature in black ink that reads "JD Boruff".

J. D. Boruff
Operations and Facilities Director
Public Works Department

City of Bloomington Contract and Purchase Justification Form

Vendor: Strauser Construction, Inc.

Contract Amount: \$93,480.00

This form should be completed and attached to the contract documents and forwarded to the Legal Department Attorney assigned to your Department. Contracts will not be approved by the Controller if a completed form is not included with the contract documents.

PURCHASE INFORMATION

1. Check the box beside the procurement method used to initiate this procurement: (Attach a quote or bid tabulation if applicable)

<input type="checkbox"/> Request for Quote (RFQ)	<input type="checkbox"/> Request for Proposal (RFP)	<input type="checkbox"/> Sole Source	<input checked="" type="checkbox"/> Not Applicable (NA)
<input type="checkbox"/> Invitation to Bid (ITB)	<input type="checkbox"/> Request for Qualifications (RFQu)	<input type="checkbox"/> Emergency Purchase	

2. List the results of procurement process. Give further explanation where requested. Yes No

# of Submittals:	Yes	No	Was the lowest cost selected? (If no, please state below why it was not.)	Yes	No
Met city requirements?	<input checked="" type="checkbox"/>	<input type="checkbox"/>		<input type="checkbox"/>	<input type="checkbox"/>
Met item or need requirements?	<input checked="" type="checkbox"/>	<input type="checkbox"/>		<input type="checkbox"/>	<input type="checkbox"/>
Was an evaluation team used?	<input checked="" type="checkbox"/>	<input checked="" type="checkbox"/>		<input type="checkbox"/>	<input type="checkbox"/>
Was scoring grid used?	<input type="checkbox"/>	<input checked="" type="checkbox"/>		<input type="checkbox"/>	<input type="checkbox"/>
Were vendor presentations requested?	<input type="checkbox"/>	<input checked="" type="checkbox"/>		<input type="checkbox"/>	<input type="checkbox"/>

3. State why this vendor was selected to receive the award and contract:

Addendum #1 to Contract with Strauser Construction, Inc. for Lower Level Renovation of Fire Station #2 will add an additional \$1,690.00, making the Do Not Exceed amount \$93,480.00.

J. D. Boruff

Facilities Director

Public Works

Print/Type Name

Print/Type Title

Department

Change Order Proposal

To: City of Bloomington - Public Works Department
Attn: J.D. Boruff

October 5, 2022

Re: Bloomington Fire Station # 2
Lower Level Renovation

Change Order Proposal # 1

Additional Work Items

Labor, material and equipment for the following work:

Item 1 - Aluminum Window Unit

- Furnish & install Fixed Aluminum Window Unit in lieu of Wood Casement Window as specified per drawings
- Color to match existing windows
- Includes 1" tinted tempered glass

Total ADD \$1,690.00

Specific Exclusions:

- All work not specifically listed above

Respectfully submitted,

Lennie Strauser
Strauser Construction Co., Inc.

Acceptance of Proposal - The above prices, specifications and conditions are satisfactory and are hereby accepted. You are authorized to do the work as specified.

Signature _____
Date _____



Board of Public Works Claim Register

Invoice Date Range 10/15/22 - 10/28/22

Vendor	Invoice Description	Contract #	Payment Date	Invoice Amount
Fund 101 - General Fund (S0101)				
Department 01 - Animal Shelter				
Program 010000 - Main				
Account 43430 - Animal Adoption Fees				
Richard Burton	01-refund adoption fee-10/12/22		10/28/2022	75.00
Kimberly Enochs	01-Chrgd full price (\$75) instead of Adpt a Dog Mnth price (\$30		10/28/2022	45.00
Karissa Jacobs	01-refund adoption fee-10/17/22		10/28/2022	30.00
Spencer Lemen	01-refund adoption fee-10/13/22		10/28/2022	75.00
Jeremy Rogers	01-refund adoption fee/rabbies vac-10/10/22		10/28/2022	75.00
Nobel Solomon	01-refund adoption fee-10/12/22		10/28/2022	75.00
Account 43430 - Animal Adoption Fees Totals			Invoice 6 Transactions	<u>\$375.00</u>
Account 43460 - Medical				
Jeremy Rogers	01-refund adoption fee/rabbies vac-10/10/22		10/28/2022	15.00
Account 43460 - Medical Totals			Invoice 1 Transactions	<u>\$15.00</u>
Account 52210 - Institutional Supplies				
313 - Fastenal Company	01-laundry detergent, paper towels		10/28/2022	120.67
4586 - Hill's Pet Nutrition Sales, INC	01-Dog & Cat Food		10/28/2022	69.30
4586 - Hill's Pet Nutrition Sales, INC	01-Prescription Pet Food		10/28/2022	111.18
4574 - John Deere Financial f.s.b. (Rural King)	01-litter-50 40lb bags pellet bedding,		10/28/2022	274.50
4549 - Kroger Limited Partnership I	01-Rabbit Food & Shelter Supplies		10/28/2022	15.21



Board of Public Works Claim Register

Invoice Date Range 10/15/22 - 10/28/22

4549 - Kroger Limited Partnership I	01-rabbit food, shelter supplies	10/28/2022	10.68
4633 - Midwest Veterinary Supply, INC	01-vet supplies ID Bands	10/28/2022	41.48
4633 - Midwest Veterinary Supply, INC	01-vet supplies ID bands	10/28/2022	41.48
4633 - Midwest Veterinary Supply, INC	01-Veterinary Supplies Gloves	10/28/2022	99.15
4633 - Midwest Veterinary Supply, INC	01-Veterinary Supplies Food Trays	10/28/2022	160.00
4633 - Midwest Veterinary Supply, INC	01-Sanitizer	10/28/2022	1,646.00
4633 - Midwest Veterinary Supply, INC	01-vet supplies anti pesasidics, PPE, antibio, anti bact, pain m	10/28/2022	1,716.87
4666 - Zoetis, INC	01-anti itch meds	10/28/2022	308.40
Account 52210 - Institutional Supplies Totals		Invoice 13 Transactions	<u>\$4,614.92</u>
Account 52310 - Building Materials and Supplies			
394 - Kleindorfer Hardware & Variety	01-Maintenance & Repair Supplies-glue	10/28/2022	6.99
Account 52310 - Building Materials and Supplies Totals		Invoice 1 Transactions	<u>\$6.99</u>
Account 52340 - Other Repairs and Maintenance			
394 - Kleindorfer Hardware & Variety	01-Shelter Parts; Repair Supplies	10/28/2022	12.78
Account 52340 - Other Repairs and Maintenance Totals		Invoice 1 Transactions	<u>\$12.78</u>
Account 52430 - Uniforms and Tools			
4447 - Municipal Emergency Services, INC	01-Uniform Scrubs	10/28/2022	63.67
4447 - Municipal Emergency Services, INC	01-Uniform Scrubs	10/28/2022	75.58
4447 - Municipal Emergency Services, INC	01-Uniform Scrubs	10/28/2022	97.88
4447 - Municipal Emergency Services, INC	01-Uniform Scrubs	10/28/2022	105.56
4447 - Municipal Emergency Services, INC	01-Uniform Scrubs	10/28/2022	144.60



Board of Public Works Claim Register

Invoice Date Range 10/15/22 - 10/28/22

		Account 52430 - Uniforms and Tools Totals	Invoice 5 Transactions	\$487.29
Account 53130 - Medical				
6529 - BloomingPaws, LLC	01-Spay/Neuter, HTW treatments		10/28/2022	1,054.26
3376 - Bloomington Pets Alive, INC	01-Spay/Neuter surgeries - 9/1/-9/29/22		10/28/2022	3,000.00
		Account 53130 - Medical Totals	Invoice 2 Transactions	\$4,054.26
Account 53540 - Natural Gas				
6769 - EDF, INC (EDF Energy Services)	06-City Fac.-Natural Gas Commodity-Sept 2022 management fee		10/19/2022	126.24
		Account 53540 - Natural Gas Totals	Invoice 1 Transactions	\$126.24
Account 53610 - Building Repairs				
4483 - City Lawn Corporation	19-SA Mowing at ACC 9/9, 15	BC 2021-104	10/28/2022	240.00
321 - Harrell Fish, INC (HFI)	01-SA Quarterly Planned Maintenance @ ACC-Summer 2022	BC 2021-111	10/28/2022	1,222.00
321 - Harrell Fish, INC (HFI)	01-AC Repair of A/C in Dog Kennel area @ ACC		10/28/2022	1,201.54
392 - Koorsen Fire & Security, INC	01-SA Annual Fire Alarm Base/Cell Net Monitoring-9/1/22-8/31/23	BC 2022-016	10/28/2022	600.00
		Account 53610 - Building Repairs Totals	Invoice 4 Transactions	\$3,263.54
		Program 010000 - Main Totals	Invoice 34 Transactions	\$12,956.02
Program 010001 - Donations Over \$5K				
Account 52210 - Institutional Supplies				
4586 - Hill's Pet Nutrition Sales, INC	01-Prescription Pet Food		10/28/2022	46.82
		Account 52210 - Institutional Supplies Totals	Invoice 1 Transactions	\$46.82
Account 53130 - Medical				
6529 - BloomingPaws, LLC	01-exam		10/28/2022	46.80



Board of Public Works Claim Register

Invoice Date Range 10/15/22 - 10/28/22

3929 - IDEXX Laboratories, INC

01-CBC, urinalysis, and other diagnostics 10/28/2022 188.34

5107 - NVA College Mall Veterinary Management INC

01-emergency visit and diagnostics 10/28/2022 567.00

Account **53130 - Medical** Totals

Invoice 3 \$802.14

Transactions

Program **010001 - Donations Over \$5K** Totals

Invoice 4 \$848.96

Transactions

Department **01 - Animal Shelter** Totals

Invoice 38 \$13,804.98

Transactions

Department **02 - Public Works**

Program **020000 - Main**

Account **52110 - Office Supplies**

1999 - CMS Communications, INC

02- New Phone Unit for Atrium Desk 10/28/2022 139.00

Account **52110 - Office Supplies** Totals

Invoice 1 \$139.00

Transactions

Account **52420 - Other Supplies**

394 - Kleindorfer Hardware & Variety

02- Yard Waste Paper Bags 10/28/2022 39.90

5819 - Synchrony Bank

02 Leaf bags for Innovation 10/28/2022 649.91

Account **52420 - Other Supplies** Totals

Invoice 2 \$689.81

Transactions

Program **020000 - Main** Totals

Invoice 3 \$828.81

Transactions

Department **02 - Public Works** Totals

Invoice 3 \$828.81

Transactions

Department **03 - City Clerk**

Program **030000 - Main**

Account **53160 - Instruction**

259 - Indiana Association Of Cities & Towns (AIM)

03-AIM Ideas Summit -N. Bolden 10/28/2022 345.00

3913 - Indiana League Of Municipal Clerks & Treasurers

03-ILMCT District Meeting- Bolden 10/28/2022 125.00



Board of Public Works Claim Register

Invoice Date Range 10/15/22 - 10/28/22

3913 - Indiana League Of Municipal Clerks & Treasurers	03-ILMCT District Meeting- Crossley	10/28/2022	125.00
3913 - Indiana League Of Municipal Clerks & Treasurers	03-ILMCT District Meeting- McDowell	10/28/2022	25.00
3913 - Indiana League Of Municipal Clerks & Treasurers	03-ILMCT District Meeting- Stoll	10/28/2022	25.00
	Account 53160 - Instruction Totals	Invoice 5 Transactions	<hr/> \$645.00
Account 53310 - Printing			
6309 - CivicPlus, LLC	03-Supplement 42, Update 1 to the Code of Ordinances-10/7/22	10/28/2022	1,371.00
	Account 53310 - Printing Totals	Invoice 1 Transactions	<hr/> \$1,371.00
	Program 030000 - Main Totals	Invoice 6 Transactions	<hr/> \$2,016.00
	Department 03 - City Clerk Totals	Invoice 6 Transactions	<hr/> \$2,016.00
Department 04 - Economic & Sustainable Dev			
Program 040000 - Main			
Account 52420 - Other Supplies			
5819 - Synchrony Bank	04: Anker USB C Hub	10/28/2022	79.49
	Account 52420 - Other Supplies Totals	Invoice 1 Transactions	<hr/> \$79.49
Account 53960 - Grants			
8323 - Nathan Blair	04: BAC & BUEA Spring 2022 Emerging Artists Grant	10/28/2022	500.00
8300 - Nikota Brault	04-BAC & BUEA Arts Fund 2022 Emerging Artists Grant -	10/28/2022	1,500.00
8301 - Justin Anthony Carney	04-BAC & BUEA Arts Fund 2022 Emerging Artists Grant -	10/28/2022	1,250.00
8324 - Ian Carstens	04-BAC & BUEA Arts Fund 2022 Emerging Artists Grant -	10/28/2022	1,500.00
7955 - Charles Eldridge Jesseph	04-BAC & BUEA Arts Fund 2022 Emerging Artists Grant -	10/28/2022	500.00
8400 - Sarah Ericson	04-BAC & BUEA Arts Fund 2022 Emerging Artists Grant -	10/28/2022	500.00



Board of Public Works Claim Register

Invoice Date Range 10/15/22 - 10/28/22

8299 - Juliet S Frey (Photospirit)	04-BAC & BUEA Arts Fund 2022 Emerging Artists Grant -	10/28/2022	2,000.00
8322 - Angela A Frezza	04-BAC & BUEA Arts Fund 2022 Emerging Artists Grant -	10/28/2022	1,000.00
8333 - Jimmy Frezza	04-BAC & BUEA Arts Fund 2022 Emerging Artists Grant -	10/28/2022	1,000.00
8383 - Mariah Gese	04-BAC & BUEA Arts Fund 2022 Emerging Artists Grant -	10/28/2022	500.00
5936 - Emily Wilson Gillespie	04-BAC & BUEA Arts Fund 2022 Emerging Artists Grant -	10/28/2022	500.00
8354 - Bethany Habegger	04-BAC & BUEA Arts Fund 2022 Emerging Artists Grant -	10/28/2022	750.00
8319 - Abby Clare Henkel	04-BAC & BUEA Arts Fund 2022 Emerging Artists Grant -	10/28/2022	500.00
8094 - Grace Leckey	04-BAC & BUEA Arts Fund 2022 Emerging Artists Grant -	10/28/2022	1,000.00
8327 - Ellen Starr Lyon	04-BAC & BUEA Arts Fund 2022 Emerging Artists Grant -	10/28/2022	750.00
8328 - Daisy Hannah May	04-BAC & BUEA Arts Fund 2022 Emerging Artists Grant -	10/28/2022	1,500.00
8302 - Katherine Robertson	04-BAC & BUEA Arts Fund 2022 Emerging Artists Grant -	10/28/2022	1,500.00
8374 - Casey LMT Rogers	04-BAC & BUEA Arts Fund 2022 Emerging Artists Grant -	10/28/2022	2,000.00
8355 - Spencer Schillerstrom	04-BAC & BUEA Arts Fund 2022 Emerging Artists Grant -	10/28/2022	500.00
8325 - Danielle L Smith (Larissa Danielle)	04-BAC & BUEA Arts Fund 2022 Emerging Artists Grant -	10/28/2022	1,000.00
Account 53960 - Grants Totals		Invoice 20 Transactions	\$20,250.00
Account 53970 - Mayor's Promotion of Business			
199 - Monroe County Government	04: Regional Climate Convening 10/4/22 Event	10/28/2022	3,747.30
Account 53970 - Mayor's Promotion of Business Totals		Invoice 1 Transactions	\$3,747.30
Account 53990 - Other Services and Charges			
6515 - Green Camino, INC (Earthkeepers)	04: City Operations Composting (City Hall, etc.)	10/28/2022	405.00
Account 53990 - Other Services and Charges Totals		Invoice 1 Transactions	\$405.00



Board of Public Works Claim Register

Invoice Date Range 10/15/22 - 10/28/22

Program **040000 - Main** Totals

Invoice 23 Transactions \$24,481.79

Program **04WALD - Waldron Arts Center**

Account **53610 - Building Repairs**

393 - Kone INC	04: WALDRON - Elevator Maintenance -August 2022	10/28/2022	185.00
393 - Kone INC	04: WALDRON - Elevator Maintenance - September 2022	10/28/2022	185.00
393 - Kone INC	04: WALDRON - Elevator Maintenance -October 2022	10/28/2022	185.00

Account **53610 - Building Repairs** Totals Invoice 3 \$555.00

Transactions

Program **04WALD - Waldron Arts Center** Totals Invoice 3 \$555.00

Transactions

Department **04 - Economic & Sustainable Dev** Totals Invoice 26 \$25,036.79

Transactions

Department **05 - Common Council**

Program **050000 - Main**

Account **53960 - Grants**

1138 - BCT Management, INC	05 - 2022 BCT Programming support - Q4	BC 2022-040	10/28/2022	13,750.00
----------------------------	--	-------------	------------	-----------

Account **53960 - Grants** Totals Invoice 1 \$13,750.00

Transactions

Program **050000 - Main** Totals Invoice 1 \$13,750.00

Transactions

Department **05 - Common Council** Totals Invoice 1 \$13,750.00

Transactions

Department **06 - Controller's Office**

Program **060000 - Main**

Account **53990 - Other Services and Charges**

5648 - Reedy Financial Group, PC	06-Financial Plan Consulting-billing through 9/30/22	10/28/2022	1,362.80
5648 - Reedy Financial Group, PC	06-TIF Financial Consulting-billing through 9/30/22	10/28/2022	2,326.45



Board of Public Works Claim Register

Invoice Date Range 10/15/22 - 10/28/22

Account **53990 - Other Services and Charges** Totals

Invoice 2 \$3,689.25

Transactions

Program **060000 - Main** Totals

Invoice 2 \$3,689.25

Transactions

Department **06 - Controller's Office** Totals

Invoice 2 \$3,689.25

Transactions

Department **07 - Engineering**

Program **070000 - Main**

Account **52420 - Other Supplies**

53442 - Paragon Micro, INC	06-Web cam for Deputy Controller	10/28/2022	64.99
6530 - Office Depot, INC	07-Dry Erase Board (for Sara Gomez)_Ruler #268092074001	10/28/2022	40.71
6530 - Office Depot, INC	07-Desk pads item#307397_INV#268092074002	10/28/2022	1.61
6530 - Office Depot, INC	07-Cabot Desk (Sara Gomez)	10/28/2022	535.99
6530 - Office Depot, INC	07-credit-return desk-Inv. 230140120001	10/28/2022	(719.99)

Account **52420 - Other Supplies** Totals

Invoice 5 (\$76.69)

Transactions

Account **54110 - Land Purchase**

19119 - Karen L Cherrington	07-ROW-B-Line Trail Multi-Use Path-Parcel 15	10/28/2022	18,970.00
8030 - Cassandra L. Slone	07-ROW-B-Line Trail Multi-Use Path-Parcel 15	10/28/2022	18,970.00

Account **54110 - Land Purchase** Totals

Invoice 2 \$37,940.00

Transactions

Program **070000 - Main** Totals

Invoice 7 \$37,863.31

Transactions

Department **07 - Engineering** Totals

Invoice 7 \$37,863.31

Transactions

Department **09 - CFRD**

Program **090000 - Main**

Account **53640 - Hardware and Software Maintenance**



Board of Public Works Claim Register

Invoice Date Range 10/15/22 - 10/28/22

53442 - Paragon Micro, INC	09- Aubrey Seader Dell Laptop, work station, and docking statio	10/28/2022	2,494.96
53442 - Paragon Micro, INC	09-Adobe Creative Cloud for Teams Annual Subscription Renewal	10/28/2022	2,873.96
Account 53640 - Hardware and Software Maintenance Totals		Invoice 2	<u>\$5,368.92</u>
		Transactions	
Program 090000 - Main Totals		Invoice 2	<u>\$5,368.92</u>
		Transactions	
Department 09 - CFRD Totals		Invoice 2	<u>\$5,368.92</u>
		Transactions	
Department 10 - Legal			
Program 100000 - Main			
Account 53120 - Special Legal Services			
19660 - Bose McKinney & Evans, LLP	10-fed funding projects & annexation-September 2022	10/28/2022	6,529.26
19660 - Bose McKinney & Evans, LLP	10-fed funding projects -10/11/22	10/28/2022	3,000.00
205 - City Of Bloomington	10-PC Reimb-Recording Fees 10/11/2022	10/28/2022	25.00
3515 - Dentons Bingham Greenebaum LLP	10-legal services DBG	10/28/2022	915.00
3515 - Dentons Bingham Greenebaum LLP	10-legal services DBG May 2022	10/28/2022	5,002.00
608 - Krieg Devault, LLP	10-legal services gov affairs September 2022	10/28/2022	2,500.00
Account 53120 - Special Legal Services Totals		Invoice 6	<u>\$17,971.26</u>
		Transactions	
Program 100000 - Main Totals		Invoice 6	<u>\$17,971.26</u>
		Transactions	
Department 10 - Legal Totals		Invoice 6	<u>\$17,971.26</u>
		Transactions	
Department 11 - Mayor's Office			
Program 110000 - Main			
Account 53310 - Printing			
129 - FedEx Office and Print Service, INC	11 -Meridiam Sign	10/28/2022	65.55



Board of Public Works Claim Register

Invoice Date Range 10/15/22 - 10/28/22

		Account 53310 - Printing Totals	Invoice 1 Transactions	\$65.55
Account 53990 - Other Services and Charges				
129 - FedEx Office and Print Service, INC	11-Poster for event		10/28/2022	65.55
7347 - Andrew B Krebbs	11-Reimb-Kroger/Party City- Board & commission thank you event		10/28/2022	42.45
4549 - Kroger Limited Partnership I	11 -Food and treats for Team retreat		10/28/2022	62.40
7149 - Namify, LLC	11-Nametags for staff		10/28/2022	49.42
		Account 53990 - Other Services and Charges Totals	Invoice 4 Transactions	\$219.82
		Program 110000 - Main Totals	Invoice 5 Transactions	\$285.37
		Department 11 - Mayor's Office Totals	Invoice 5 Transactions	\$285.37
Department 12 - Human Resources				
Program 120000 - Main				
Account 52110 - Office Supplies				
6530 - Office Depot, INC	12-red file folders		10/28/2022	65.54
		Account 52110 - Office Supplies Totals	Invoice 1 Transactions	\$65.54
Account 53990 - Other Services and Charges				
585 - Bloomington Public Transportation Corporation	12-City Pass Program July 2022-September 2022		10/28/2022	156.00
7759 - Turning Point Initiatives (Center for Equity)	12-Anti Racism Training - follow ups, coaching, planning team #7		10/28/2022	33,756.00
		Account 53990 - Other Services and Charges Totals	Invoice 2 Transactions	\$33,912.00
		Program 120000 - Main Totals	Invoice 3 Transactions	\$33,977.54
		Department 12 - Human Resources Totals	Invoice 3 Transactions	\$33,977.54
Department 13 - Planning				



Board of Public Works Claim Register

Invoice Date Range 10/15/22 - 10/28/22

Program 130000 - Main

Account 52420 - Other Supplies

53442 - Paragon Micro, INC	13-Dell Computer Monitor 24" (2nd monitor for Eric Greulich)	10/28/2022	234.99
53442 - Paragon Micro, INC	13-Dell 24" Monitor	10/28/2022	234.99

Account 52420 - Other Supplies Totals	Invoice 2	\$469.98
	Transactions	

Account 53990 - Other Services and Charges

53442 - Paragon Micro, INC	13-Adobe Cloud (P&T staff - total 11)_ 9/22/22 - 9/22/23	10/28/2022	11,098.89
----------------------------	--	------------	-----------

Account 53990 - Other Services and Charges Totals	Invoice 1	\$11,098.89
	Transactions	

Program 130000 - Main Totals	Invoice 3	\$11,568.87
	Transactions	

Department 13 - Planning Totals	Invoice 3	\$11,568.87
	Transactions	

Department 19 - Facilities Maintenance

Program 190000 - Main

Account 52310 - Building Materials and Supplies

409 - Black Lumber Co. INC	19- WP outside corner shelving @ PW Facilities	10/28/2022	12.98
409 - Black Lumber Co. INC	19- WP outside corner and WP parting Stop for shelving	10/28/2022	16.47
177 - Indiana Oxygen Company, INC	19-Oxygen Rental	10/28/2022	40.20
394 - Kleindorfer Hardware & Variety	19-screws,brackets,sloans,spray primer,tool oil, super/wood glue	10/28/2022	201.84
394 - Kleindorfer Hardware & Variety	19-(2) 4" cut off wheels for Facilities	10/28/2022	6.98

Account 52310 - Building Materials and Supplies Totals	Invoice 5	\$278.47
	Transactions	

Account 52430 - Uniforms and Tools

19171 - Aramark Uniform & Career Apparel Group, INC	19-Uniforms for Facility Employees for 10/6/22	10/28/2022	30.84
---	--	------------	-------



Board of Public Works Claim Register

Invoice Date Range 10/15/22 - 10/28/22

19171 - Aramark Uniform & Career Apparel Group, INC	19-Uniforms for Facility Employees for 8/25/2022		10/28/2022	30.84
19171 - Aramark Uniform & Career Apparel Group, INC	19-Uniforms for Facility Employees-10/13/22		10/28/2022	30.84
Account 52430 - Uniforms and Tools Totals			Invoice 3 Transactions	\$92.52
Account 53530 - Water and Sewer				
208 - City Of Bloomington Utilities	19-City Hall-water/sewer bill - Sept 2022			2,934.57
Account 53530 - Water and Sewer Totals			Invoice 1 Transactions	\$2,934.57
Account 53610 - Building Repairs				
32 - Cassady Electrical Contractors, INC	19-SA Wired Fire Alarm Panel to Server @ City Hall	BC 2021-103	10/28/2022	394.95
4483 - City Lawn Corporation	19-SA Mowing at 2541 W 3rd St 9/8,14,21,28	BC 2021-104	10/28/2022	210.00
4483 - City Lawn Corporation	19-SA Mowing at 1910 W 3rd 9/8,14,21,28	BC 2021-104	10/28/2022	168.00
4483 - City Lawn Corporation	19-SA Mowing at 2nd & Weimer 9/8,21	BC 2021-104	10/28/2022	73.50
4483 - City Lawn Corporation	19-SA Mowing at Tapp/Rockport 9/10,21	BC 2021-104	10/28/2022	73.50
4483 - City Lawn Corporation	19-SA Mowing at City Hall September 2022	BC 2021-104	10/28/2022	210.00
321 - Harrell Fish, INC (HFI)	19-SA Repair of Condensation Leak in Public Works Suite	BC 2021-111	10/28/2022	3,302.73
321 - Harrell Fish, INC (HFI)	19-SA Quarterly Planned Maintenance @ City Hall-Oct 2022	BC 2021-111	10/28/2022	2,027.00
393 - Kone INC	19-SA City Hall Elevator Maintenance for Aug 2022	BC 2022-024	10/28/2022	185.00
393 - Kone INC	19-SA City Hall Elevator Maintenance for Sept 2022	BC 2022-024	10/28/2022	185.00
393 - Kone INC	19-SA City Hall Elevator Maintenance for October 2022	BC 2022-024	10/28/2022	185.00
392 - Koorsen Fire & Security, INC	19-SA Fire Alarm Repair at City Hall	BC 2022-016	10/28/2022	534.49
392 - Koorsen Fire & Security, INC	19-SA Fire Alarm Repair Service Call @ City Hall	BC 2022-016	10/28/2022	268.95
7402 - Nature's Way, INC	19-SA Monthly Maintenance Billing-October 2022	BC 2021-141	10/28/2022	364.03



Board of Public Works Claim Register

Invoice Date Range 10/15/22 - 10/28/22

Account 53610 - Building Repairs Totals	Invoice 14	\$8,182.15
	Transactions	
Program 190000 - Main Totals	Invoice 23	\$11,487.71
	Transactions	
Department 19 - Facilities Maintenance Totals	Invoice 23	\$11,487.71
	Transactions	
Fund 101 - General Fund (S0101) Totals	Invoice 125	\$177,648.81
	Transactions	

Fund 103 - Restricted Donations(ord 05-17)

Department 06 - Controller's Office

Program 400101 - Animal Medical Services

Account 53130 - Medical

50350 - Arlington Heights Veterinary Hospital, INC	01-emergency surgery and repair	10/28/2022	538.00
3376 - Bloomington Pets Alive, INC	01-Spay/Neuter surgeries - 9/1/-9/29/22	10/28/2022	7,578.00
54639 - Shake Veterinary Services, INC (Town & Country Vet	01-Surgeries & Diagnostics	10/28/2022	760.95
6788 - Brian Thunberg (Mobile Animal Surgical Care, Co)	01-follow up x-rays, consult	10/28/2022	312.10

Account 53130 - Medical Totals	Invoice 4	\$9,189.05
	Transactions	
Program 400101 - Animal Medical Services Totals	Invoice 4	\$9,189.05
	Transactions	
Department 06 - Controller's Office Totals	Invoice 4	\$9,189.05
	Transactions	
Fund 103 - Restricted Donations(ord 05-17) Totals	Invoice 4	\$9,189.05
	Transactions	

Fund 176 - ARPA Local Fiscal Recvry (S9512)

Department 04 - Economic & Sustainable Dev

Program G21005 - ARPA COVID Local Fiscal Recovery

Account 53960 - Grants

6714 - Dimension Mill, INC	04: ARPA Grant for Bloomington Remote - Mill-2022	10/28/2022	25,000.00
----------------------------	---	------------	-----------



Board of Public Works Claim Register

Invoice Date Range 10/15/22 - 10/28/22

55092 - WonderLab Museum of Science, Health & Technology	04: WonderLab SEEL Grant	10/28/2022	10,000.00
	Account 53960 - Grants Totals	Invoice 2	<u>\$35,000.00</u>
	Program G21005 - ARPA COVID Local Fiscal Recovery Totals	Transactions Invoice 2	<u>\$35,000.00</u>
	Department 04 - Economic & Sustainable Dev Totals	Transactions Invoice 2	<u>\$35,000.00</u>
		Transactions	
Department 20 - Street			
Program G21005 - ARPA COVID Local Fiscal Recovery			
Account 53630 - Machinery and Equipment Repairs			
19681 - Southeastern Equipment Co, INC	20-Millig Machine repairs parts (Collars/teeth)	10/28/2022	573.27
	Account 53630 - Machinery and Equipment Repairs Totals	Invoice 1	<u>\$573.27</u>
	Program G21005 - ARPA COVID Local Fiscal Recovery Totals	Transactions Invoice 1	<u>\$573.27</u>
	Department 20 - Street Totals	Transactions Invoice 1	<u>\$573.27</u>
	Fund 176 - ARPA Local Fiscal Recvry (S9512) Totals	Transactions Invoice 3	<u>\$35,573.27</u>
		Transactions	
Fund 450 - Local Road and Street(S0706)			
Department 20 - Street			
Program 200000 - Main			
Account 53520 - Street Lights / Traffic Signals			
223 - Duke Energy	02 - 3rd & Indiana signal- elec charges for 9/3 - 10/4/22	10/19/2022	50.06
	Account 53520 - Street Lights / Traffic Signals Totals	Invoice 1	<u>\$50.06</u>
	Program 200000 - Main Totals	Transactions Invoice 1	<u>\$50.06</u>
	Department 20 - Street Totals	Transactions Invoice 1	<u>\$50.06</u>
	Fund 450 - Local Road and Street(S0706) Totals	Transactions Invoice 1	<u>\$50.06</u>
		Transactions	



Board of Public Works Claim Register

Invoice Date Range 10/15/22 - 10/28/22

Fund 451 - Motor Vehicle Highway(S0708)

Department **20 - Street**

Program **200000 - Main**

Account 52210 - Institutional Supplies

313 - Fastenal Company	20-Safety Supplies for Crews	10/28/2022	335.42
313 - Fastenal Company	20-Safety Supplies for Crews	10/28/2022	159.00
Account 52210 - Institutional Supplies Totals		Invoice 2 Transactions	\$494.42

Account 53250 - Pagers

332 - Indiana Paging Network, INC	20-Pagers for snow control -November 2022	10/28/2022	86.14
Account 53250 - Pagers Totals		Invoice 1 Transactions	\$86.14

Account 53410 - Liability / Casualty Premiums

1847 - Hylant of Indianapolis, LLC	20-2020 John Deere 6110M to Insurance Policy	10/28/2022	235.00
20275 - The Travelers Indemnity	20-Insurance Deductible to Kinser/Corns-4/28/21	10/28/2022	5,000.00
Account 53410 - Liability / Casualty Premiums Totals		Invoice 2 Transactions	\$5,235.00

Account 53540 - Natural Gas

6769 - EDF, INC (EDF Energy Services)	06-City Fac.-Natural Gas Commodity-Sept 2022 management fee	10/19/2022	14.27
222 - Indiana Gas Co. INC (CenterPoint Energy) (Vectren)	20-Street Dept-gas bill 9/7-10/6/22	10/19/2022	27.15
222 - Indiana Gas Co. INC (CenterPoint Energy) (Vectren)	20-Traffic bldg-gas bill 9/7-10/6/22	10/19/2022	21.19
Account 53540 - Natural Gas Totals		Invoice 3 Transactions	\$62.61

Account 53920 - Laundry and Other Sanitation Services

19171 - Aramark Uniform & Career Apparel Group, INC	20-Mat Services for Street Department-9/28/22	10/28/2022	34.28
---	---	------------	-------



Board of Public Works Claim Register

Invoice Date Range 10/15/22 - 10/28/22

Account 53920 - Laundry and Other Sanitation Services Totals		Invoice 1	\$34.28
Account 53990 - Other Services and Charges		Transactions	
321 - Harrell Fish, INC (HFI)	20-Certified backflow testing on Street Building	10/28/2022	175.00
902 - Indiana Underground Plant Protection Service, INC	20-Line Locate Services -September 2022-836 tickets	10/28/2022	794.20
Account 53990 - Other Services and Charges Totals		Invoice 2	\$969.20
		Transactions	
Program 200000 - Main Totals		Invoice 11	\$6,881.65
		Transactions	
Department 20 - Street Totals		Invoice 11	\$6,881.65
		Transactions	
Fund 451 - Motor Vehicle Highway(S0708) Totals		Invoice 11	\$6,881.65
		Transactions	
Fund 452 - Parking Facilities(S9502)			
Department 26 - Parking			
Program 260000 - Main			
Account 43160 - Lot/Garage Leases - Annual			
Desiree Branaman	26- Refund for duplicate garage pass	10/28/2022	58.00
Account 43160 - Lot/Garage Leases - Annual Totals		Invoice 1	\$58.00
		Transactions	
Account 52420 - Other Supplies			
4394 - Richardson Enterprises of Blgtn,LLC (FastSigns)	26-ADA Signs, Bike Area, Elevator, Windmaster	10/28/2022	2,198.46
Account 52420 - Other Supplies Totals		Invoice 1	\$2,198.46
		Transactions	
Account 53610 - Building Repairs			
4483 - City Lawn Corporation	19-SA Mowing at 4th/Washington 9/6,15,21,28	BC 2021-104 10/28/2022	126.00
4483 - City Lawn Corporation	26-SA Mowing at 4th/Washington 7/6,14,27	BC 2021-104 10/28/2022	94.50
393 - Kone INC	26-Beyond Scope SA-Repair Driver-Morton St Garage-7/25/22	BC 2022-020 10/28/2022	4,307.05



Board of Public Works Claim Register

Invoice Date Range 10/15/22 - 10/28/22

393 - Kone INC	26-SA Maintenance Garages- 08/01-08/31/2022	BC 2022-024	10/28/2022	1,695.00
393 - Kone INC	26- SA Maintenance-Pkg Garages-8/01-8/31/22	BC 2022-024	10/28/2022	1,695.00
393 - Kone INC	26- SA Beyond Scope- 5 yr Safety Test & Hoistway Cleandown	BC 2022-020	10/28/2022	9,995.67
	Account 53610 - Building Repairs Totals		Invoice 6	<u>\$17,913.22</u>
			Transactions	
	Program 260000 - Main Totals		Invoice 8	<u>\$20,169.68</u>
			Transactions	
	Department 26 - Parking Totals		Invoice 8	<u>\$20,169.68</u>
			Transactions	
	Fund 452 - Parking Facilities(S9502) Totals		Invoice 8	<u>\$20,169.68</u>
			Transactions	

Fund 454 - Alternative Transport(S6301)

Department **26 - Parking**

Program **260000 - Main**

Account **52430 - Uniforms and Tools**

5695 - 1818 Apparel Co., INC (dba Freethink AppareI)	26-HATS FOR PARKING OFFICERS		10/28/2022	12.60
	Account 52430 - Uniforms and Tools Totals		Invoice 1	<u>\$12.60</u>
			Transactions	
	Program 260000 - Main Totals		Invoice 1	<u>\$12.60</u>
			Transactions	
	Department 26 - Parking Totals		Invoice 1	<u>\$12.60</u>
			Transactions	
	Fund 454 - Alternative Transport(S6301) Totals		Invoice 1	<u>\$12.60</u>
			Transactions	

Fund 455 - Parking Meter Fund(S2141)

Department **26 - Parking**

Program **260000 - Main**

Account **52110 - Office Supplies**

5819 - Synchrony Bank	26-Office supplies - mouse pads 3 pk		10/28/2022	6.19
-----------------------	--------------------------------------	--	------------	------



Board of Public Works Claim Register

Invoice Date Range 10/15/22 - 10/28/22

5819 - Synchrony Bank	26-post it notes - slips - desk org		10/28/2022	76.34
Account 52110 - Office Supplies Totals		Invoice 2		<u>\$82.53</u>
Account 52340 - Other Repairs and Maintenance		Transactions		
6688 - SSW Enterprises, LLC (Office Pride)	26-cleaning service for Parking Enforcement Offices	BC 2022-077	10/28/2022	487.00
Account 52340 - Other Repairs and Maintenance Totals		Invoice 1		<u>\$487.00</u>
Account 52420 - Other Supplies		Transactions		
394 - Kleindorfer Hardware & Variety	26-misc parking supplies		10/28/2022	9.28
394 - Kleindorfer Hardware & Variety	26-misc parking supplies		10/28/2022	2.07
394 - Kleindorfer Hardware & Variety	26-misc parking supplies		10/28/2022	37.96
394 - Kleindorfer Hardware & Variety	26-misc parking supplies		10/28/2022	24.06
5819 - Synchrony Bank	26-webcam		10/28/2022	69.83
5819 - Synchrony Bank	26-clock for officer area		10/28/2022	15.99
5819 - Synchrony Bank	26-file holder - tape - stapler -file folder		10/28/2022	49.19
5819 - Synchrony Bank	26-Iphone case - otter box - hdmi cabls		10/28/2022	81.73
5819 - Synchrony Bank	26-wall clock for parking office		10/28/2022	11.73
Account 52420 - Other Supplies Totals		Invoice 9		<u>\$301.84</u>
Account 52430 - Uniforms and Tools		Transactions		
5695 - 1818 Apparel Co., INC (dba Freethink AppareI)	26-HATS FOR PARKING OFFICERS		10/28/2022	50.40
4447 - Municipal Emergency Services, INC	26-shorts for Charlene Lawson		10/28/2022	87.64
Account 52430 - Uniforms and Tools Totals		Invoice 2		<u>\$138.04</u>
Account 53640 - Hardware and Software Maintenance		Transactions		



Board of Public Works Claim Register

Invoice Date Range 10/15/22 - 10/28/22

54432 - T2 Systems, INC	26-Rovr returns for Sept 2022	10/28/2022	639.60
Account 53640 - Hardware and Software Maintenance Totals		Invoice 1	<u>639.60</u>
		Transactions	
Account 53830 - Bank Charges			
4264 - IPS Group, INC	26-transaction and card fees for Sep 2022	10/28/2022	13,658.39
Account 53830 - Bank Charges Totals		Invoice 1	<u>13,658.39</u>
		Transactions	
Account 53910 - Dues and Subscriptions			
204 - State Of Indiana	26-BMV lookups for towing	10/28/2022	15.00
Account 53910 - Dues and Subscriptions Totals		Invoice 1	<u>15.00</u>
		Transactions	
Program 260000 - Main Totals		Invoice 17	<u>15,322.40</u>
		Transactions	
Department 26 - Parking Totals		Invoice 17	<u>15,322.40</u>
		Transactions	
Fund 455 - Parking Meter Fund(S2141) Totals		Invoice 17	<u>15,322.40</u>
		Transactions	
Fund 456 - MVH Restricted			
Department 20 - Street			
Program 200000 - Main			
Account 52340 - Other Repairs and Maintenance			
818 - Everywhere Signs, LLC	20-Faris Farm street sign replacement	10/28/2022	320.00
Account 52340 - Other Repairs and Maintenance Totals		Invoice 1	<u>320.00</u>
		Transactions	
Account 52420 - Other Supplies			
409 - Black Lumber Co. INC	20-Misc Supplies for/Sidewalk/Pavement/Sign Crews	10/28/2022	65.54
394 - Kleindorfer Hardware & Variety	20-Blanket for supplies/paving crews-diamond saw blades	10/28/2022	147.98
Account 52420 - Other Supplies Totals		Invoice 2	<u>213.52</u>
		Transactions	



Board of Public Works Claim Register

Invoice Date Range 10/15/22 - 10/28/22

Program 200000 - Main Totals	Invoice 3	\$533.52
	Transactions	
Department 20 - Street Totals	Invoice 3	\$533.52
	Transactions	
Fund 456 - MVH Restricted Totals	Invoice 3	\$533.52
	Transactions	

Fund **600 - Cumulative Cap Imprv(CIG)(S2379)**

Department **02 - Public Works**

Program **020000 - Main**

Account **52330 - Street , Alley, and Sewer Material**

334 - Irving Materials, INC	20-Walnut St Pk/Heather-Concrete for sidewalks & ADA ramps	BC 2022-010	10/28/2022	720.00	
334 - Irving Materials, INC	20-Allendale & Walnut St Pk-Concrete for sidewalks & ADA ramps	BC 2022-010	10/28/2022	500.00	
334 - Irving Materials, INC	20-Walnut St Pk/Heather-Concrete for sidewalks & ADA ramps	BC 2022-010	10/28/2022	540.00	
Account 52330 - Street , Alley, and Sewer Material Totals				Invoice 3	\$1,760.00
				Transactions	
Program 020000 - Main Totals				Invoice 3	\$1,760.00
				Transactions	
Department 02 - Public Works Totals				Invoice 3	\$1,760.00
				Transactions	
Fund 600 - Cumulative Cap Imprv(CIG)(S2379) Totals				Invoice 3	\$1,760.00
				Transactions	

Fund **601 - Cumulative Capital Devlp(S2391)**

Department **02 - Public Works**

Program **020000 - Main**

Account **52330 - Street , Alley, and Sewer Material**

19278 - Milestone Contractors, LP	20-Asphalt (Patching)	BC 2021-19	10/28/2022	303.53	
Account 52330 - Street , Alley, and Sewer Material Totals				Invoice 1	\$303.53
				Transactions	

Account **52420 - Other Supplies**



Board of Public Works Claim Register

Invoice Date Range 10/15/22 - 10/28/22

409 - Black Lumber Co. INC	20-Misc Supplies for crews-shop towels	10/28/2022	11.99
409 - Black Lumber Co. INC	20-Misc Supplies for crews-stanley tape, spray paint	10/28/2022	80.97
313 - Fastenal Company	20-White spray paint for marking line locate areas	10/28/2022	198.74
Account 52420 - Other Supplies Totals		Invoice 3	\$291.70
Program 020000 - Main Totals		Transactions Invoice 4	\$595.23
Department 02 - Public Works Totals		Transactions Invoice 4	\$595.23
Fund 601 - Cumulative Capital Devlp(S2391) Totals		Transactions Invoice 4	\$595.23
		Transactions	
Fund 730 - Solid Waste (S6401)			
Department 16 - Sanitation			
Program 160000 - Main			
Account 52420 - Other Supplies			
7225 - Arctic Glacier USA, INC	16-80 Bags of Ice - minus damaged bags	10/28/2022	146.40
394 - Kleindorfer Hardware & Variety	16-Cleaning products for trucks	10/28/2022	26.27
Account 52420 - Other Supplies Totals		Invoice 2	\$172.67
		Transactions	
Account 53150 - Communications Contract			
5465 - Emergency Radio Service LLC (ERS-OCI Wireless)	16-Wireless Radio Service for October 2022	10/28/2022	572.05
Account 53150 - Communications Contract Totals		Invoice 1	\$572.05
		Transactions	
Account 53410 - Liability / Casualty Premiums			
20275 - The Travelers Indemnity	16-Insurance Claim 2021 - Cameron Miller-4/7/21	10/28/2022	5,000.00
20275 - The Travelers Indemnity	16-Insurance Claim 2021-Blgtn Superior Fuel-6/29/21	10/28/2022	2,516.75
20275 - The Travelers Indemnity	16-Insurance Claim 2021-Lori Wiedeman-7/19/21	10/28/2022	5,000.00



Board of Public Works Claim Register

Invoice Date Range 10/15/22 - 10/28/22

20275 - The Travelers Indemnity	16-Insurance Claim 2021-Hien Nguyen-8/30/21		10/28/2022	2,949.11
20275 - The Travelers Indemnity	16-Insurance Claim 2021-Randy Tackett-9/23/21		10/28/2022	1,031.94
20275 - The Travelers Indemnity	16-Insurance Claim 2021-Brian Rothman-9/27/21		10/28/2022	4,213.13
Account 53410 - Liability / Casualty Premiums Totals			Invoice 6 Transactions	<u>\$20,710.93</u>
Account 53540 - Natural Gas				
6769 - EDF, INC (EDF Energy Services)	06-City Fac.-Natural Gas Commodity-Sept 2022 management fee		10/19/2022	5.32
222 - Indiana Gas Co. INC (CenterPoint Energy) (Vectren)	16-Sanitation-gas bill 9/2-10/4/22			50.15
Account 53540 - Natural Gas Totals			Invoice 2 Transactions	<u>\$55.47</u>
Account 53920 - Laundry and Other Sanitation Services				
19171 - Aramark Uniform & Career Apparel Group, INC	16-uniform rental (minus payroll ded)- 9/28/2022		10/28/2022	4.62
19171 - Aramark Uniform & Career Apparel Group, INC	16-uniform rental (minus payroll ded)- 10/5/22		10/28/2022	4.62
19171 - Aramark Uniform & Career Apparel Group, INC	16-Mat Services - 10-5-2022		10/28/2022	23.26
Account 53920 - Laundry and Other Sanitation Services Totals			Invoice 3 Transactions	<u>\$32.50</u>
Account 53950 - Landfill				
6515 - Green Camino, INC (Earthkeepers)	16-Landfill-yard waste - September 2022	BC 2022-021	10/28/2022	95.58
52226 - Hoosier Transfer Station-3140	16-recycling fees-9/19-9/29/22		10/28/2022	2,448.07
52226 - Hoosier Transfer Station-3140	16-trash disposal fees-9/17-9/30/22		10/28/2022	14,565.59
Account 53950 - Landfill Totals			Invoice 3 Transactions	<u>\$17,109.24</u>
Account 53990 - Other Services and Charges				
392 - Koorsen Fire & Security, INC	16-Fire alarm Inspection; replacement batteries		10/28/2022	491.44
392 - Koorsen Fire & Security, INC	16-Fire Alarm repair & inspection-communicator, Lte Fire Network		10/28/2022	534.49



Board of Public Works Claim Register

Invoice Date Range 10/15/22 - 10/28/22

392 - Koorsen Fire & Security, INC

16-Fire alarm monitoring 10/1-12/31/22	10/28/2022	101.79
Account 53990 - Other Services and Charges Totals	Invoice 3	<u>\$1,127.72</u>
	Transactions	
Program 160000 - Main Totals	Invoice 20	<u>\$39,780.58</u>
	Transactions	
Department 16 - Sanitation Totals	Invoice 20	<u>\$39,780.58</u>
	Transactions	
Fund 730 - Solid Waste (S6401) Totals	Invoice 20	<u>\$39,780.58</u>
	Transactions	

Fund **800 - Risk Management(S0203)**

Department **10 - Legal**

Program **100000 - Main**

Account **52430 - Uniforms and Tools**

8613 - Crane's Leather & Shoe Shop, INC

10-safety shoes-B. Norman (13D)-9/26/22	10/28/2022	100.00
Account 52430 - Uniforms and Tools Totals	Invoice 1	<u>\$100.00</u>
	Transactions	
Program 100000 - Main Totals	Invoice 1	<u>\$100.00</u>
	Transactions	
Department 10 - Legal Totals	Invoice 1	<u>\$100.00</u>
	Transactions	
Fund 800 - Risk Management(S0203) Totals	Invoice 1	<u>\$100.00</u>
	Transactions	

Fund **801 - Health Insurance Trust**

Department **12 - Human Resources**

Program **120000 - Main**

Account **53990 - Other Services and Charges**

3977 - Cigna Health & Life Insurance Company

12-October 2022 Cigna Dental/Vision Invoice	10/28/2022	2,072.40
\$10,114.61		
Account 53990 - Other Services and Charges Totals	Invoice 1	<u>\$2,072.40</u>
	Transactions	

Account **53990.1201 - Other Services and Charges Health Insurance**



Board of Public Works Claim Register

Invoice Date Range 10/15/22 - 10/28/22

17785 - The Howard E. Nyhart Company, INC	12-October 2022 Wellness Reimbursements	10/19/2022	17,826.00
Account 53990.1201 - Other Services and Charges Health Insurance Totals		Invoice 1	<u>\$17,826.00</u>
		Transactions	
Program 120000 - Main Totals		Invoice 2	<u>\$19,898.40</u>
		Transactions	
Department 12 - Human Resources Totals		Invoice 2	<u>\$19,898.40</u>
		Transactions	
Fund 801 - Health Insurance Trust Totals		Invoice 2	<u>\$19,898.40</u>
		Transactions	
Fund 802 - Fleet Maintenance(S9500)			
Department 17 - Fleet Maintenance			
Program 170000 - Main			
Account 52230 - Garage and Motor Supplies			
50605 - Bauer Built, INC	17 - tires for stock and scrap tire disposal	10/28/2022	3,113.80
50605 - Bauer Built, INC	17 - 315/80R225 tires for stock	10/28/2022	4,193.80
50605 - Bauer Built, INC	17 -scrap tire disposal for Commercial & Light Trucks	10/28/2022	57.75
50605 - Bauer Built, INC	17 - 2 used 315/80R225 & (2) 31580R225 retread tires for stock	10/28/2022	1,023.28
50605 - Bauer Built, INC	17 - tires for stock- 10/7/2022	10/28/2022	3,539.24
50605 - Bauer Built, INC	17 -(2) 2" MX HD Rubber track tires	10/28/2022	4,010.00
4693 - Monroe County Tire & Supply, INC	17 - (2) Firestone Bias Tube TR13 26/24x12-12 for stock	10/28/2022	50.00
4693 - Monroe County Tire & Supply, INC	17 - 4 - Goodyear Wrangler SRA 100S Owl tires	10/28/2022	451.76
4693 - Monroe County Tire & Supply, INC	17 - 4 - M'craft Stratus HT 106T Black tires	10/28/2022	521.00
53385 - O'Reilly Automotive Stores, INC	17- credit for core return -Invoice #1903-311676	10/28/2022	(150.00)
Account 52230 - Garage and Motor Supplies Totals		Invoice 10	<u>\$16,810.63</u>
		Transactions	
Account 52240 - Fuel and Oil			



Board of Public Works Claim Register

Invoice Date Range 10/15/22 - 10/28/22

613 - Hoosier Penn Oil Company, INC	17 - HP Group II AW 68 Hydra 1/55 Oil	10/28/2022	624.80
7854 - Premier AG CO-OP, INC (Premier Energy)	17-diesel fuel-6,969 gallons-9/29/22	BC 2021-84D 10/28/2022	28,361.74
Account 52240 - Fuel and Oil Totals		Invoice 2 Transactions	\$28,986.54
Account 52320 - Motor Vehicle Repair			
4150 - Alexander's LLC	17-wheel for Truck #569	10/28/2022	99.95
4135 - Andy Mohr Truck Center	17 - stock mirrors	10/28/2022	2,543.13
244 - Bloomington Ford, INC	17- Tension Pulley part for ford	10/28/2022	23.32
244 - Bloomington Ford, INC	17- Control Unit for ford	10/28/2022	25.50
244 - Bloomington Ford, INC	17- Link, nuts, hex nut and bush parts for ford	10/28/2022	128.78
244 - Bloomington Ford, INC	17- Headlight assembly and bumper cover for ford	10/28/2022	567.03
244 - Bloomington Ford, INC	17- credit for part return -Invoice #5077764	10/28/2022	(400.00)
941 - Central Indiana Truck Equipment Corporation	17- Throttle switch truck parts	10/28/2022	61.77
5792 - Clark Truck Equipment Co., INC	17 - #409 shaft and chains	10/28/2022	122.00
5792 - Clark Truck Equipment Co., INC	17 - #4241 tank, bracket, feed jack,oiller, lockwasher,nut,screw	10/28/2022	454.00
21104 - Cummins Crosspoint, LLC	17-Stud & Nut for #332	10/28/2022	62.88
21104 - Cummins Crosspoint, LLC	17- Pressure sensor, turbocharger actuator & Actuator kit - #332	10/28/2022	191.84
21104 - Cummins Crosspoint, LLC	17- credit for 2 HE300VG Turbos return-Inv N8-23523	10/28/2022	(675.00)
21104 - Cummins Crosspoint, LLC	17- Trubocharger, actuator & turbo actuator Kits parts for #332	10/28/2022	1,719.90
21104 - Cummins Crosspoint, LLC	17- work preformed at Cummins for #341	10/28/2022	2,004.56
21104 - Cummins Crosspoint, LLC	17 turbocharger kit for #332	10/28/2022	5,482.15
4992 - Fleetpride, INC	17- credit for (8) Core Cast Open end Cam return	10/28/2022	(3,840.00)



Board of Public Works Claim Register

Invoice Date Range 10/15/22 - 10/28/22

4992 - Fleetpride, INC	17-#341 brake parts	10/28/2022	7,011.84
455 - Industrial Service & Supply, INC	17-hydraulic fittings	10/28/2022	322.57
2974 - MacAllister Machinery Co, INC	17- misc. CAT parts - Switch Kit	10/28/2022	128.66
53385 - O'Reilly Automotive Stores, INC	17- misc. truck parts -Anti-Theft	10/28/2022	25.49
53385 - O'Reilly Automotive Stores, INC	17- misc. truck parts - Thermostat	10/28/2022	10.89
53385 - O'Reilly Automotive Stores, INC	17- misc. truck parts - Anti-Theft	10/28/2022	25.49
53385 - O'Reilly Automotive Stores, INC	17- misc. truck parts - Coolant Hose	10/28/2022	26.33
53385 - O'Reilly Automotive Stores, INC	17- misc. truck parts - Water Pump	10/28/2022	27.58
53385 - O'Reilly Automotive Stores, INC	17- misc. truck parts - Tensioner	10/28/2022	51.58
53385 - O'Reilly Automotive Stores, INC	17- misc. truck parts - Control Arm Assembly	10/28/2022	204.58
53385 - O'Reilly Automotive Stores, INC	17- misc. truck parts - LSR Iridium	10/28/2022	156.32
53385 - O'Reilly Automotive Stores, INC	17- misc. truck parts - Brake Rotor	10/28/2022	157.00
16069 - Palmer Trucks, INC	17- Radiator cap for #773	10/28/2022	24.08
16069 - Palmer Trucks, INC	17- credit for valve-relay return -Inv #I358725	10/28/2022	(83.90)
16069 - Palmer Trucks, INC	17- purge valve kit for #772	10/28/2022	99.94
16069 - Palmer Trucks, INC	17- Roppel condensor & Sealing A/C washer #8for #772	10/28/2022	127.67
476 - Southern Indiana Parts, INC (Napa Auto Parts)	17 - various parts for various vehicles for September	10/28/2022	7,905.28
54351 - Sternberg, INC	17-misc. International parts - Steering link	10/28/2022	122.35
54351 - Sternberg, INC	17-misc. International parts - Hose & Seal	10/28/2022	159.28
54351 - Sternberg, INC	17-misc. International parts - Absorber	10/28/2022	178.74
54351 - Sternberg, INC	17-misc. International parts - Steering arm	10/28/2022	214.98



Board of Public Works Claim Register

Invoice Date Range 10/15/22 - 10/28/22

54351 - Sternberg, INC	17-misc. International parts - Cylinder	10/28/2022	626.79
54351 - Sternberg, INC	17 - Fuel Module	10/28/2022	67.97
6216 - Terminal Supply, INC	17 - stock light bars	10/28/2022	3,912.80
582 - Town & Country Chrysler Dodge Jeep, INC	17- Chrysler parts - Radiator	10/28/2022	510.00
582 - Town & Country Chrysler Dodge Jeep, INC	17- misc. Chrysler parts - Radiator ; Engine Coolant	10/28/2022	510.00
7555 - VoMac Truck Sales & Service INC	17- misc. mack parts - Oil Fuel Pressure Sensor	10/28/2022	75.14
7555 - VoMac Truck Sales & Service INC	17- misc. mack parts - Wiper	10/28/2022	138.94
7555 - VoMac Truck Sales & Service INC	17- misc. mack parts - Cap	10/28/2022	169.74
7555 - VoMac Truck Sales & Service INC	17- misc. mack parts - Pressure Regulator	10/28/2022	223.09
2096 - West Side Tractor Sales CO.	17- misc. John Deere parts - Filter Elements & oil Filter	10/28/2022	133.79
2096 - West Side Tractor Sales CO.	17- misc. John Deere parts - V-Belt & Switch for 735	10/28/2022	247.91
Account 52320 - Motor Vehicle Repair Totals		Invoice 49 Transactions	<u>\$32,084.73</u>
Account 53540 - Natural Gas			
6769 - EDF, INC (EDF Energy Services)	06-City Fac.-Natural Gas Commodity-Sept 2022 management fee	10/19/2022	11.31
222 - Indiana Gas Co. INC (CenterPoint Energy) (Vectren)	17-Fleet Maint-gas bill 9/7-10/6/22	10/19/2022	57.19
Account 53540 - Natural Gas Totals		Invoice 2 Transactions	<u>\$68.50</u>
Account 53610 - Building Repairs			
4483 - City Lawn Corporation	19-SA Mowing at Fleet 9/29	BC 2021-104 10/28/2022	36.75
Account 53610 - Building Repairs Totals		Invoice 1 Transactions	<u>\$36.75</u>
Account 53620 - Motor Repairs			
4474 - Ken's Westside Service & Towing, LLC	17 -towing-Unit #765-10/3/22	10/28/2022	70.00



Board of Public Works Claim Register

Invoice Date Range 10/15/22 - 10/28/22

4474 - Ken's Westside Service & Towing, LLC	17-towing-Unit #1210-9/30/22	10/28/2022	75.00
	Account 53620 - Motor Repairs Totals	Invoice 2 Transactions	<u>\$145.00</u>
Account 53920 - Laundry and Other Sanitation Services			
19171 - Aramark Uniform & Career Apparel Group, INC	17 - City portion Of uniform rentals- 9/28/2022	10/28/2022	19.50
19171 - Aramark Uniform & Career Apparel Group, INC	17 - mat rentals & Shop towels - 10/05/2022	10/28/2022	77.36
19171 - Aramark Uniform & Career Apparel Group, INC	17 - uniform rentals for 10/05/2022	10/28/2022	19.50
	Account 53920 - Laundry and Other Sanitation Services Totals	Invoice 3 Transactions	<u>\$116.36</u>
	Program 170000 - Main Totals	Invoice 69 Transactions	<u>\$78,248.51</u>
	Department 17 - Fleet Maintenance Totals	Invoice 69 Transactions	<u>\$78,248.51</u>
	Fund 802 - Fleet Maintenance(S9500) Totals	Invoice 69 Transactions	<u>\$78,248.51</u>
Fund 804 - Insurance Voluntary Trust			
Department 12 - Human Resources			
Program 120000 - Main			
Account 53990.1241 - Other Services and Charges Vision			
3977 - Cigna Health & Life Insurance Company	12-October 2022 Cigna Dental/Vision Invoice \$10,114.61	10/28/2022	8,042.21
	Account 53990.1241 - Other Services and Charges Vision Totals	Invoice 1 Transactions	<u>\$8,042.21</u>
Account 53990.1271 - Other Services and Charges Section 125 - URM- City			
17785 - The Howard E. Nyhart Company, INC	12-City URM	10/17/2022	68.11
17785 - The Howard E. Nyhart Company, INC	12-City URM	10/17/2022	180.00
17785 - The Howard E. Nyhart Company, INC	12-City URM	10/17/2022	44.00
17785 - The Howard E. Nyhart Company, INC	12-City/Util URM	10/18/2022	56.68



Board of Public Works Claim Register

Invoice Date Range 10/15/22 - 10/28/22

17785 - The Howard E. Nyhart Company, INC	12-City URM		310.22
17785 - The Howard E. Nyhart Company, INC	12-City/Util URM		55.00
Account 53990.1271 - Other Services and Charges Section 125 - URM- City Totals			Invoice 6 Transactions <u>\$714.01</u>
Account 53990.1281 - Other Services and Charges Section 125 - URM- Util			
17785 - The Howard E. Nyhart Company, INC	12-City/Util URM	10/18/2022	85.00
17785 - The Howard E. Nyhart Company, INC	12-City/Util URM		27.29
Account 53990.1281 - Other Services and Charges Section 125 - URM- Util Totals			Invoice 2 Transactions <u>\$112.29</u>
Account 53990.1283 - Other Services and Charges Health Savings Account			
17785 - The Howard E. Nyhart Company, INC	12-Nyhart HSA EE Contributions 10-20-2022		18,456.53
Account 53990.1283 - Other Services and Charges Health Savings Account Totals			Invoice 1 Transactions <u>\$18,456.53</u>
Program 120000 - Main Totals			Invoice 10 Transactions <u>\$27,325.04</u>
Department 12 - Human Resources Totals			Invoice 10 Transactions <u>\$27,325.04</u>
Fund 804 - Insurance Voluntary Trust Totals			Invoice 10 Transactions <u>\$27,325.04</u>
Grand Totals			Invoice 282 Transactions <u><u>\$433,088.80</u></u>

REGISTER OF CLAIMS
Board: Board of Public Works Claim Register

Date:	Type of Claim	FUND	Description	Bank Transfer	Amount
10/28/22	Claims				\$433,088.80
					<u>\$433,088.80</u>

ALLOWANCE OF CLAIMS

We have examined the claims listed on the foregoing register of claims, consisting of claims, and except for the claims not allowed as shown on the register, such claims are hereby allowed in the total amount of \$433,088.80

Dated this 25th day of October year of 2022.

<u>Kyla Cox Deckard, President</u>	<u>Jennifer Lloyd, Vice President</u>	<u>Elizabeth Karon, Secretary</u>

I hereby certify that each of the above listed voucher(s) or bill(s) is (are) true and correct and I have audited same in accordance with IC 5-11-10-1.6.

Fiscal Office _____