

# **Board of Public Works Meeting**

## **January 31, 2023**



The City will offer virtual options, including CATS public access television (live and tape-delayed) and

Public comments and questions will be encouraged via Zoom or [bloomington.in.gov](http://bloomington.in.gov) rather than in person

**REVISED AGENDA  
BOARD OF PUBLIC WORKS  
January 31, 2023**

A Regular Meeting of the Board of Public Work will be held Tuesday, January 31, 2023 at 5:30 p.m. in the Council Chambers (Rm #115) of City Hall at the Showers Building, 401 N. Morton Street, Bloomington, Indiana and via Zoom by using the following link:

<https://bloomington.zoom.us/j/87851257536?pwd=Y2RFSG5pK1q0T0IPSHJVQzVqQlk2dz09>

**Meeting ID: 878 5125 7536 Passcode: 761787**

The City offers virtual options, including CATS public access television (live and tape- delayed). Comments and questions will be encouraged via Zoom or [bloomington.in.gov](http://bloomington.in.gov) rather than in person.

**Auxiliary aids for people with disabilities are available upon request with adequate notice. Please call 812-349-3411 or email [public.works@bloomington.in.gov](mailto:public.works@bloomington.in.gov).**

**I. MESSAGES FROM BOARD MEMBERS**

**II. PETITIONS AND REMONSTANCES**

**III. CONSENT AGENDA**

1. Approval of Minutes January 17, 2023
2. 2023 4<sup>th</sup> Street Arts Festival
3. 2<sup>nd</sup> Year Extension of ParkMobile Agreement
4. Approval of Payroll

**IV. NEW BUSINESS**

1. Request from Duke Energy for Street, Lane, and Sidewalk Closures (February 01, 2023- June 30, 2023)
2. Request from The Standard to Extend Lane Closure on E 14<sup>th</sup> Street
3. Request from Fox Construction for Lane Closures along 2<sup>nd</sup> and W. Patterson
4. Request from AEG for Lane and Sidewalk Closures

**V. STAFF REPORTS & OTHER BUSINESS**

1. Rejection of Bids for Hopewell Phase I Infrastructure Project

**VI. APPROVAL OF CLAIMS**

**VII. ADJOURNMENT**



The Board of Public Works meeting was held Tuesday, January 17, 2023 at 5:30 pm in the Council Chambers of City Hall at 401 N. Morton St., Bloomington, Indiana and virtually through Zoom with Kyla Cox Deckard presiding.

**REGULAR MEETING OF THE BOARD OF PUBLIC WORKS**

Present: Kyla Cox Deckard  
Elizabeth Karon  
Jennifer Lloyd

**ROLL CALL**

City Staff: Adam Wason – Public Works  
Larry Allen – City Legal  
Paul Kehrberg – Engineering  
Alex Gray – Engineering  
Jason Kerr -- Engineering

**MESSAGES FROM BOARD MEMBERS**

None

**PETITIONS & REMONSTRANCES**

None

1. Approval of Minutes; January 03, 2023
2. Amendment to CentralSquare Agreement for Custom Report Development
3. 2023 Kone Service Agreement for Public Works Facilities
4. Noise Permit for Rally for Life
5. Approval of Payroll

**CONSENT AGENDA**

**Board Comments:** None

Karon made a motion to approve the Consent Agenda. Lloyd seconded. All in favor, motion is passed.

Adam Wason, Public Works, presented Resolution 2023-01; Uphold Order to Remove 1001 N. Jackson St. on behalf of Mike Arnold, Housing and Neighborhood Development. See meeting packet for details.

**NEW BUSINESS**  
**Resolution 2023-01; Uphold Order to Remove 1001 N. Jackson St.**

**Board Comments:** None

Karon made a motion to approve Resolution 2023-01; Uphold Order to Remove 1001 N. Jackson St. Lloyd seconded. All in favor, motion is passed.

Adam Wason, Public Works, presented Resolution 2023-02; Uphold Order to Remove 1707 W. Gray St. on behalf of Mike Arnold, Housing and Neighborhood Development. See meeting packet for details.

**Resolution 2023-02; Uphold Order to Remove 1707 W. Gray St.**

**Board Comments:** None

Karon made a motion to approve Resolution 2023-02; Uphold Order to Remove 1707 W. Gray St. Lloyd seconded. All in favor, motion is passed.

Larry Allen, City Legal, presented Resolution 2023-03; Updated Community Special Events Application. See meeting packet for details.

**Board Comments:** None

Karon made a motion to approve Resolution 2023-03; Updated Community Special Events Application. Lloyd seconded. All in favor, motion is passed.

Paul Kehrberg, Engineering, presented Request from Shuck Corporation for Lane and Sidewalk Closures on N. Pete Ellis Dr. (January 18, 2023-February 10, 2023). See meeting packet for details.

**Board Comments:** None

Karon made a motion to approve Request from Shuck Corporation for Lane and Sidewalk Closures on N. Pete Ellis Dr. (January 18, 2023-February 10, 2023). Lloyd seconded. All in favor, motion is passed.

Alex Gray, Engineering, presented Request from JDH Contracting for Temporary Lane and Sidewalk Closures on N. Monroe St. and W. Cottage Grove Ave. (January 18, 2023-February 03, 2023). See meeting packet for details.

**Board Comments:** None

Karon made a motion to approve Request from JDH Contracting for Temporary Lane and Sidewalk Closures on N. Monroe St. and W. Cottage Grove Ave. (January 18, 2023-February 03, 2023). Lloyd seconded. All in favor, motion is passed.

Jason Kerr, Engineering, presented Request from AEG for Lane and Sidewalk Closures. See meeting packet for details.

**Board Comments:** None

Karon made a motion to approve Request from AEG for Lane and Sidewalk Closures. Lloyd seconded. All in favor, motion is passed.

Adam Wason thanked Animal Control Officer Vickie Minder for her 22 years of service at Animal Care and Control and wished her well in her retirement. Cox Deckard mentioned a time when Minder gave her some advice on a small kitten, and stated she is appreciative of the hard work of the staff at Animal Care and Control.

Karon mentioned that she did not see a signature sheet in the packet and wanted to be certain she was approving the correct amount on claims. Wason verified the amount. Karon made a motion to approve claims in the amount of \$3,549,012.59. Lloyd seconded. All in favor, motion is passed.

Cox Deckard called for adjournment at 5:47 p.m.

**Resolution 2023-03; Updated Community Special Events Application**

**Request from Shuck Corporation for Lane and Sidewalk Closures on N. Pete Ellis Dr. (January 18, 2023-February 10, 2023)**

**Request from JDH Contracting for Temporary Lane and Sidewalk Closures on N. Monroe St. and W. Cottage Grove Ave. (January 18, 2023-February 03, 2023)**

**Request from AEG for Lane and Sidewalk Closures**

**STAFF REPORTS AND OTHER BUSINESS**

**CLAIMS**

**ADJOURNMENT**

Accepted By:

\_\_\_\_\_  
Kyla Cox Deckard, President

\_\_\_\_\_  
Elizabeth Karon, Vice President

\_\_\_\_\_  
Jennifer Lloyd, Secretary

Date:

Attest to:

01/17/2023



## Board of Public Works Staff Report

---

**Project/Event:** The 46th Annual 4th Street Festival of the Arts and Crafts

**Petitioner/Representative:** Brenden King/4<sup>th</sup> Street Arts Festival

**Staff Representative:** Holly Warren

**Meeting Date:** January 31, 2023

---

Planners for the 4th Street Festival of the Arts and Crafts wish to request the closure of Fourth Street from Indiana to Lincoln (excluding Dunn St.), and Grant Street between Kirkwood and the Alley south of Café Bali (210 S. Grant), Friday September 1st through Sunday, September 3rd for this year's 46th annual festival which will be September 2, 2023 – September 3, 2023. The Petitioner has requested that the closure begin Friday, September 1st at 8am to allow time for artists to set up booths and teardown will be complete by 9 pm on Sunday, September 3, 2023.

The 4th Street Festival of the Arts and Crafts is the single largest arts event in the city with tens of thousands of attendees. This festival serves as the opening act to the fall arts and cultural season in Bloomington and brings many visitors downtown to patronize restaurants and retail. A resolution with a hold harmless agreement and noise waiver has been prepared. Insurance will also be provided. A noise waiver application has been included as well as the Waste & Recycling Management Plan.

**BOARD OF PUBLIC WORKS  
RESOLUTION 2023-04**

**4TH STREET FESTIVAL OF THE ARTS AND CRAFTS**

WHEREAS, the Board of Public Works is empowered by I.C. 36-9-6-2 to supervise City Streets; and

WHEREAS, the City has committed itself to promoting the arts; and

WHEREAS, 4<sup>th</sup> Street Arts Festival, is desirous of using 4th Street, between S. Lincoln Street and S. Indiana Avenue (not including Dunn St.); and S. Grant Street, between E. Kirkwood Avenue and the alley south of Café Bali (210 S. Grant St.); to host the 46th Annual 4th Street Festival of the Arts and Crafts; and

WHEREAS, 4<sup>th</sup> Street Arts Festival has requested that the Board close certain streets in downtown Bloomington to traffic and parking from 8:00 am on Friday the 1st day of September, 2023, until 9 pm on Sunday, the 3rd day of September, 2023, so that the 4th Street Festival, Inc., can have control over the streets for the purposes of providing an outdoor art show of high quality that is mutually beneficial to the artists and the community; and

WHEREAS, 4<sup>th</sup> Street Festival, Inc., has agreed to provide the City with a Certificate of Insurance naming the City of Bloomington as additionally insured.

NOW, THEREFORE, BE IT RESOLVED that the City of Bloomington approves the event herein described, provided:

1. The Board of Public Works declares the above-described event to be an approved Special Event for purposes of Chapters 4.16, 4.28 and 4.30 of the Bloomington Municipal Code.
2. The City of Bloomington Board of Public Works declares that 4th Street, between S. Lincoln Street and S. Indiana Avenue (not including Dunn St.) from 8 am on Friday, September 01, 2023 until 9 pm on Sunday, September 03, 2023; and S. Grant Street, between E. Kirkwood Avenue and the alley south of Café Bali (210 S. Grant St) from 1 pm on Friday, September 01, 2023 until 9 pm on Sunday, September 03, 2023 will be temporarily closed to traffic and parking.

3. The street closures outlined above are for the purposes of allowing the 4th Street Arts Festival to provide an outdoor art show of high quality that is mutually beneficial to the artists and the community on Saturday, September 2<sup>nd</sup> and Sunday, September 3<sup>rd</sup>, 2023.
4. The artists, performers, craftsperson and vendors who have not received explicit authorization from the 4th Street Arts Festival or their representatives or agents, to participate in the 4th Street Festival of the Arts and Crafts, shall not be permitted to utilize the closed off portions of the streets or sidewalks outlined above for the purposes of performing, displaying, producing or selling items or goods.
5. 4th Street Arts Festival shall work with City of Bloomington Parking Enforcement regarding a requested closure of any parking spaces. Parking Enforcement shall post "No Parking" signs at appropriate parking spaces at least 24 hours in advance of their closure.
6. 4th Street Festival Arts shall be responsible for placement and removal of barricades. 4th Street Arts Festival is responsible for contacting the City's Engineering Department for instructions on the type of and placement of said barricades. 4th Street Festival Arts agrees to obtain at its own expense and place barricades to close the streets, not before 8am on Friday, the 1st day of September, 2023 and to remove barricades by midnight on Sunday, September 3, 2023
7. 4th Street Arts Festival will be responsible for removing all trash, picking up litter including cigarette butts from the street and sidewalks within these blocks, cleaning any grease or other food products from the pavement and sidewalks, and removing any "No Parking" signs posted as part of the event. Cleanup shall be completed by midnight on Sunday, September 3<sup>rd</sup>, 2023.
8. By granting permission to utilize City property to facilitate this activity, the City also waives the City Noise Ordinance in accordance with Section 14.09.070 of the Bloomington Municipal Code, and therefore amplified sound and music may be played during the hours of the event.
9. 4th Street Arts Festival shall be responsible for notifying the general public, public transit and public safety agencies of the street closing in advance by notice at least 48 hours in advance.
10. 4th Street Arts Festival shall be responsible for developing, enacting, and enforcing an Emergency Action Plan covering emergencies, including but not limited to weather related emergencies, that may arise during the course of the 4th Street Festival of the Arts and Crafts, a copy of which 4th Street Arts Festival agrees to submit to City of Bloomington staff at least thirty (30) days prior to the beginning of the 4th Street Festival of the Arts and Crafts;



11. In consideration for the use of the City’s property and to the fullest extent permitted by law, 4th Street Arts Festival for itself, its officers, directors, agents, employees, members, successors and assigns, does hereby indemnify and hold harmless the City of Bloomington, the Board, and the offices, agents and employees of the City and the Board from any and all claims, demands, damages, costs, expenses or other liability arising out of bodily injury or property damage (collectively “Claims”) which may occur as a result of the use of said property, including, but not limited to, any claim or claims brought by third parties, whether or not sounding in tort or contract.
12. That \_\_\_\_\_, by signing this agreement, represents that he/she has been fully empowered by proper action of the entity to enter into the agreement and has authority to do so.

ADOPTED THIS 31<sup>st</sup> DAY OF JANUARY, 2023.

BOARD OF PUBLIC WORKS:

4TH Street Arts Festival

\_\_\_\_\_  
Kyla Cox Deckard, President

\_\_\_\_\_  
Signature

\_\_\_\_\_  
Elizabeth Karon, Vice President

\_\_\_\_\_  
Printed Name

\_\_\_\_\_  
Jennifer Lloyd, Secretary

\_\_\_\_\_  
Date

January 31, 2023  
Date



CITY OF BLOOMINGTON

# SPECIAL EVENT APPLICATION

City of Bloomington  
Department of Economic and Sustainable Development  
401 N. Morton Street, Suite 150  
Bloomington, Indiana 47404  
812-349-3418  
Department of Public Works  
812-349-3411

## 1. APPLICANT INFORMATION

Contact Name:	Brenden Klyg		
Contact Phone:	765 490 1714	Mobile Phone:	765 490 1714
Title/Position:	Director		
Organization:	4 <sup>th</sup> Street Festival of the Arts + Crafts		
Address:	PO Box 1257		
City, State, Zip:	Bloomington IN 47402		
Contact E-Mail Address:	<del>4thstreetfestival</del> 4thstreetfestival@mail.com		
Organization E-Mail and URL:	4thstreet.org		
Org Phone No:	812-575-0484	Fax No:	N/A

## 2. ANY KEY PARTNERS INVOLVED (including Food Vendors if applicable)

Organization Name:	N/A		
Address:			
City, State, Zip:			
Contact E-Mail Address:			
Phone Number:		Mobile Phone:	
Organization Name:			
Address:			
City, State, Zip:			
E-Mail Address:			
Phone Number:		Mobile Phone:	
Organization Name:			
Address:			
City, State, Zip:			
E-Mail Address:			
Phone Number:		Mobile Phone:	

### 3. EVENT INFORMATION

Type of Event	<input type="checkbox"/> Metered Parking Space(s) <input type="checkbox"/> Run/Walk <input checked="" type="checkbox"/> Festival <input type="checkbox"/> Block Party <input type="checkbox"/> Parade <input type="checkbox"/> Art in the Right of Way <input type="checkbox"/> Other (Explain below in Description of Event)	
Date(s) of Event:	Sept 2nd + 3rd, 2023	
Time of Event:	Date: Sept 2nd Start: 10AM	Date: Sept 3rd End: 5pm
Setup/Teardown time Needed	Date: Sept 1st Start: 8AM	Date: Sept 3rd End: 9PM
Calendar Day of Week:	Friday - Setup . Sat - Sun: Festival	
Description of Event:	Annual Bloomington tradition since 1977. We are one of the largest art events in Bloomington. In 2022 we had a crowd of more than 30,000 people. It attracts thousands to the downtown area. This influx of art enthusiasts bring business to local artists as well as shops, restaurants + hotels in Bloomington.	
Expected Number of Participants:	150 Festival workers 39,000 patrons	Expected # of vehicles (Use of Parking Spaces to close): ?

### 4. IF YOUR EVENT IS A NEIGHBORHOOD BLOCK PARTY, YOU ARE REQUIRED TO SECURE AND ATTACH THE FOLLOWING:

<input type="checkbox"/>	A map of the proposed rights-of-way closure or route in its entirety (streets shall be properly labeled and identified) <ul style="list-style-type: none"> <li>The starting point shall be clearly marked</li> <li>The ending point shall be clearly marked</li> <li>Each intersection along the route shall be clearly identified</li> <li>A notation of how each intersection is to be blocked shall be specifically noted at each intersection (where type 3 barricades will be placed)</li> </ul>
<input type="checkbox"/>	Notification to businesses/residents that will be impacted by event (copy of notification letter/flyer/other)
<input type="checkbox"/>	A properly executed Maintenance of Traffic Plan <ul style="list-style-type: none"> <li>Determine if No Parking Signs will be required</li> </ul>
<input type="checkbox"/>	Noise Permit application



**5. IF YOUR EVENT IS A RUN/WALK/PARADE, YOU ARE REQUIRED TO SECURE AND ATTACHED THE FOLLOWING: *Moving Events – Use and/or Closure of City Streets/Sidewalks***

<input type="checkbox"/>	A map of the proposed rights-of-way closure or route in its entirety (streets shall be properly labeled and identified) <ul style="list-style-type: none"> <li>The starting point shall be clearly marked</li> <li>The ending point shall be clearly marked</li> <li>The number of lanes to be restricted on each road shall be clearly marked</li> <li>Each intersection along the route shall be clearly identified</li> <li>A notation of how each intersection is to be blocked shall be specifically noted at each intersection (i.e.: Type 3 barricades and/or law enforcement); and</li> <li>The location of any staging area(s) for the rights-of-way closure and how much space the staging area(s) shall utilize</li> </ul>
<input type="checkbox"/>	Notification to businesses /residents that will be impacted by event of the day the application will be heard by Board of Public Works (Example attached)
<input type="checkbox"/>	Using a City park or trail? Parks & Recreation Department Approved Special Use Permit <input type="checkbox"/> Not applicable
<input type="checkbox"/>	Certificate of Liability Insurance – Proof of insurance listing the City of Bloomington as additional insured for an amount no less than \$1,000,000 per occurrence and \$2,000,000 in the aggregate. <b>DEADLINE:</b> To Public Works no later than five days before event.
<input type="checkbox"/>	A properly executed Maintenance of Traffic Plan *Determine if No Parking Signs will be required      * Determine if Barricades will be required
<input type="checkbox"/>	Secured a Parade Permit from Bloomington Police Department <input type="checkbox"/> Not applicable
<input type="checkbox"/>	Noise Permit application <input type="checkbox"/> Not applicable
<input type="checkbox"/>	Waste and Recycling Plan if more than 100 participates (template attached)

**6. IF YOUR EVENT IS A FESTIVAL/SPECIAL COMMUNITY EVENT YOU ARE REQUIRED TO SECURE AND ATTACH, AND SUBMIT THE FOLLOWING: *Stationary Events – Closure of Streets/Sidewalks/Use of Metered Parking***

<input checked="" type="checkbox"/>	A map of the proposed rights-of-way closure in its entirety (streets shall be properly labeled and identified) The starting point shall be clearly marked <ul style="list-style-type: none"> <li>The ending point shall be clearly marked</li> <li>The number of lanes to be restricted on each road shall be clearly marked</li> <li>Each intersection along the route shall be clearly identified</li> <li>A notation of how each intersection is to be blocked shall be specifically noted at each intersection (ie: type 3 barricades and/or law enforcement); and</li> <li>The location of any staging area(s) for the rights-of-way closure and how much space the staging area(s) shall utilize</li> </ul>
<input checked="" type="checkbox"/>	Notification to business/residents who will be impacted by event of the day the application will be heard by Board of Public Works (Example attached)
<input type="checkbox"/>	Using a City park or trail? Parks & Recreation Department Approved Special Use Permit <input checked="" type="checkbox"/> Not applicable
<input checked="" type="checkbox"/>	A properly executed Maintenance of Traffic Plan *Determine if No Parking Signs will be required      * Determine if Barricades will be required
<input checked="" type="checkbox"/>	Noise Permit application <input type="checkbox"/> Not applicable
<input type="checkbox"/>	Beer & Wine Permit <input checked="" type="checkbox"/> Not applicable
<input checked="" type="checkbox"/>	Certificate of Liability Insurance listing the City of Bloomington as additional insured. For an amount not less than \$1,000,000 per occurrence and \$2,000,000 in the aggregate. <b>DEADLINE:</b> To Public Works no later than five days before event.
<input type="checkbox"/>	If Food Vendors are part of Festival (Monroe County Health Department Licenses & Fire Inspection)
<input checked="" type="checkbox"/>	Waste and Recycling Plan if more than 100 participates (template attached)

## 7. CHECKLIST

<input checked="" type="checkbox"/>	Determine type of Event
<input checked="" type="checkbox"/>	<p>Complete application with attachment:</p> <ul style="list-style-type: none"> <li><input checked="" type="checkbox"/> Detailed Map</li> <li><input checked="" type="checkbox"/> Proof of notification to businesses/residents (copy of letter/flyer/other)</li> <li><input checked="" type="checkbox"/> Maintenance of Traffic Plan</li> <li><input checked="" type="checkbox"/> Noise Permit Application (if applicable)</li> <li><input checked="" type="checkbox"/> Certificate of Liability Insurance</li> <li><input type="checkbox"/> Secured a Parade Permit from Bloomington Police Department (if applicable)</li> <li><input type="checkbox"/> Beer and Wine Permit (if applicable)Waste and Recycling Plan (if applicable)</li> <li><input checked="" type="checkbox"/> Waste and Recycling Plan (if applicable)</li> <li><input checked="" type="checkbox"/> For art installations: an accurate depiction of the design of private art to scale, dimensions of the art, placement on the detailed map of proposed location of the art, and the name and qualifications of the artist</li> </ul>
<input checked="" type="checkbox"/>	Date Application will be heard by Board of Public Works
<input type="checkbox"/>	Approved Parks Special Use Permit (if using a City Park)
<input type="checkbox"/>	If using food vendors assure proper paperwork in order (Monroe County Health Department Licenses & Fire Inspection)
<input checked="" type="checkbox"/>	If applicable, acknowledgment of compliance with the City of Bloomington Policy and Procedures on Private Art Installations within the Public Right of Way (Policy attached with application)

### FOR CITY OF BLOOMINGTON USE ONLY

Date Received:	Received By:	Date Approved:	Approved By:
	Economic & Sustainable Development		
	Bloomington Police		
	Bloomington Fire		
	Engineering		
	Transit		
	Office of the Mayor		
	Utilities		
	Public Works		
	Board of Public Works		





CITY OF BLOOMINGTON

# NOISE PERMIT

City of Bloomington  
401 N. Morton St., Suite 120  
Bloomington, Indiana 47404  
812-349-3410

## Application and Permit Information

This is an application for a permit for relief from Chapter 14.09 (Noise Control) of the Bloomington Municipal Code. Any permit granted by the City of Bloomington must contain all conditions upon which said permit shall be effective. The City may prescribe any reasonable conditions or requirements it deems necessary to minimize adverse effects upon the community or the surrounding neighborhood.

Once a completed application is submitted to the City, it will be reviewed by the Board of Public Works. If the permit is approved, the holder must still abide all other city, state, and federal laws.

Contact April Rosenberger with any questions: (812) 349-3410 or [april.rosenberger@bloomington.in.gov](mailto:april.rosenberger@bloomington.in.gov)

## Event and Noise Information

Name of Event:	4 <sup>th</sup> Street Arts		
Location of Event:	4 <sup>th</sup> st between Lincoln + Indiana Ave Grant between Kirkwood + 3 <sup>rd</sup>		
Date of Event:	September 2nd + 3rd 2023	Time of Event:	Start: 10AM
Calendar Day of Week:	Saturday + Sunday		End: 6PM
Description of Event:	music tent playing amplified music + spoken word amplified poetry		
Source of Noise:	<input checked="" type="checkbox"/> Live Band	<input checked="" type="checkbox"/> Instrument	<input type="checkbox"/> Loudspeaker
			Will Noise be Amplified? <input checked="" type="checkbox"/> Yes <input type="checkbox"/> No
Is this a Charity Event?	<input type="checkbox"/> Yes <input type="checkbox"/> No	If Yes, to Benefit:	4 <sup>th</sup> st ss 50161

## Applicant Information

Name:	Brenden King		
Organization:	4 <sup>th</sup> st committee	Title:	Director
Physical Address:	NA		
Email Address:	4 <sup>th</sup> street festival@gmail.com	Phone Number:	765-490-1714
Signature:		Date:	6/11/23

## FOR CITY OF BLOOMINGTON USE ONLY

In accordance with Section 14.09.070 of the Bloomington Municipal Code, We, the Board of Public Works, the designee of the Mayor of the City of Bloomington, hereby waive the City Noise Ordinance for the above mentioned event.

### BOARD OF PUBLIC WORKS

Kyla Cox Deckard, President

Elizabeth Karon, Vice-President

Date

Jennifer Lloyd, Secretary





# CERTIFICATE OF LIABILITY INSURANCE

DATE (MM/DD/YYYY)

01/11/2023

THIS CERTIFICATE IS ISSUED AS A MATTER OF INFORMATION ONLY AND CONFERS NO RIGHTS UPON THE CERTIFICATE HOLDER. THIS CERTIFICATE DOES NOT AFFIRMATIVELY OR NEGATIVELY AMEND, EXTEND OR ALTER THE COVERAGE AFFORDED BY THE POLICIES BELOW. THIS CERTIFICATE OF INSURANCE DOES NOT CONSTITUTE A CONTRACT BETWEEN THE ISSUING INSURER(S), AUTHORIZED REPRESENTATIVE OR PRODUCER, AND THE CERTIFICATE HOLDER.

**IMPORTANT:** If the certificate holder is an ADDITIONAL INSURED, the policy(ies) must have ADDITIONAL INSURED provisions or be endorsed. If SUBROGATION IS WAIVED, subject to the terms and conditions of the policy, certain policies may require an endorsement. A statement on this certificate does not confer rights to the certificate holder in lieu of such endorsement(s).

<b>PRODUCER</b> First Insurance Group 1405 N. College Avenue  Bloomington IN 47404		<b>CONTACT NAME:</b> Beth Jones <b>PHONE (A/C, No. Ext):</b> (812) 331-3230 <b>E-MAIL ADDRESS:</b> bethj@figprotects.com <b>FAX (A/C, No.):</b>	
		<b>INSURER(S) AFFORDING COVERAGE</b> INSURER A: Cincinnati Insurance Co	<b>NAIC #</b> 10677
<b>INSURED</b> Fourth Street Festival Corp. P.O. Box 1257  Bloomington IN 47402		<b>INSURER B:</b> <b>INSURER C:</b> <b>INSURER D:</b> <b>INSURER E:</b> <b>INSURER F:</b>	

**COVERAGES**

CERTIFICATE NUMBER: CL2311114871

REVISION NUMBER:

THIS IS TO CERTIFY THAT THE POLICIES OF INSURANCE LISTED BELOW HAVE BEEN ISSUED TO THE INSURED NAMED ABOVE FOR THE POLICY PERIOD INDICATED. NOTWITHSTANDING ANY REQUIREMENT, TERM OR CONDITION OF ANY CONTRACT OR OTHER DOCUMENT WITH RESPECT TO WHICH THIS CERTIFICATE MAY BE ISSUED OR MAY PERTAIN, THE INSURANCE AFFORDED BY THE POLICIES DESCRIBED HEREIN IS SUBJECT TO ALL THE TERMS, EXCLUSIONS AND CONDITIONS OF SUCH POLICIES. LIMITS SHOWN MAY HAVE BEEN REDUCED BY PAID CLAIMS.

INSR LTR	TYPE OF INSURANCE	ADDL INSD	SUBR WVD	POLICY NUMBER	POLICY EFF (MM/DD/YYYY)	POLICY EXP (MM/DD/YYYY)	LIMITS
A	<input checked="" type="checkbox"/> <b>COMMERCIAL GENERAL LIABILITY</b> <input type="checkbox"/> CLAIMS-MADE <input checked="" type="checkbox"/> OCCUR  GEN'L AGGREGATE LIMIT APPLIES PER: <input type="checkbox"/> POLICY <input type="checkbox"/> PRO-JECT <input type="checkbox"/> LOC OTHER:			ENP 0057245	01/01/2023	01/01/2024	EACH OCCURRENCE \$ 1,000,000 DAMAGE TO RENTED PREMISES (Ea occurrence) \$ 100,000 MED EXP (Any one person) \$ 5,000 PERSONAL & ADV INJURY \$ 1,000,000 GENERAL AGGREGATE \$ 2,000,000 PRODUCTS - COMP/OP AGG \$ 2,000,000
A	<b>AUTOMOBILE LIABILITY</b> <input type="checkbox"/> ANY AUTO <input type="checkbox"/> OWNED AUTOS ONLY <input type="checkbox"/> SCHEDULED AUTOS <input checked="" type="checkbox"/> HIRED AUTOS ONLY <input checked="" type="checkbox"/> NON-OWNED AUTOS ONLY			ENP 0057245	01/01/2023	01/01/2024	COMBINED SINGLE LIMIT (Ea accident) \$ BODILY INJURY (Per person) \$ 1,000,000 BODILY INJURY (Per accident) \$ PROPERTY DAMAGE (Per accident) \$ Uninsured motorist \$ ACV
	<b>UMBRELLA LIAB</b> <b>EXCESS LIAB</b> OCCUR CLAIMS-MADE DED RETENTION \$						PROPERTY DAMAGE EACH OCCURRENCE \$ AGGREGATE \$
	<b>WORKERS COMPENSATION AND EMPLOYERS' LIABILITY</b> ANY PROPRIETOR/PARTNER/EXECUTIVE OFFICER/MEMBER EXCLUDED? (Mandatory in NH) If yes, describe under DESCRIPTION OF OPERATIONS below						PER STATUTE OTH-ER E.L. EACH ACCIDENT \$ E.L. DISEASE - EA EMPLOYEE \$ E.L. DISEASE - POLICY LIMIT \$

DESCRIPTION OF OPERATIONS / LOCATIONS / VEHICLES (ACORD 101, Additional Remarks Schedule, may be attached if more space is required)

Certificate Holder is an Additional Insured with regard to General Liability as required by written agreement.

**CERTIFICATE HOLDER****CANCELLATION**

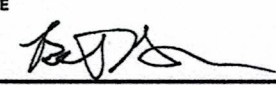
City of Bloomington 401 N Morton St Ste 130  Bloomington IN 47402	SHOULD ANY OF THE ABOVE DESCRIBED POLICIES BE CANCELLED BEFORE THE EXPIRATION DATE THEREOF, NOTICE WILL BE DELIVERED IN ACCORDANCE WITH THE POLICY PROVISIONS.  AUTHORIZED REPRESENTATIVE 
--	--

© 1988-2015 ACORD CORPORATION. All rights reserved.



## Waste and Recycling Management Plan Template

Event name: 4th Street Art Festival  
 Number of expected attendees: 40K  
 Number of food vendors: 2  
 Number of other vendors: 125 artists

**Designated waste and recycling manager:** This may be a staff member or a volunteer. Events expecting over 100 attendees are required to designate a waste and recycling manager who will be in charge of overseeing the implementation of the waste and recycling management plan.

**Event map:** In the event map you submit with your event application, please clearly designate where waste and recycling bins will be placed. Each waste bin should be paired with one or more recycling bins. Also designate any larger collection areas (such as dumpsters) and the path for access by waste haulers.

**TIP:** Recycling bins should be visually distinct from waste bins, and all bins should be clearly labeled for easy use by attendees. ClearStream recycling bins are available for use through Downtown Bloomington, Inc.

**Targeted waste:** Please enumerate the types of waste expected at the event and plans for collecting each type of item using the following table. Examples are listed, but feel free to modify as appropriate.

Type of waste	Collection plan
<Containers>*	<Recycling, composting, etc.>
<Mixed paper>	<Recycling in on-site, designated bins staffed by volunteers>
<Food waste>	<Composting bins, waste bins, etc.>

\*Note that "compostable" plastics are only compostable in industrial composters, which are not available in the Bloomington area. If you opt for compostable items at your event, ensure that they are compostable paper rather than plastic.

**Collection and hauling system:** Describe where and how waste and recycling will be collected and separated. Include information on how attendees and vendors will be educated on where materials should be placed, including signage, pre-event training and publicity, volunteer-staffed waste management stations, etc.

Events with over 100 attendees must provide staffed (by paid staff or volunteers) waste management stations to ensure that materials are separated according to the waste and recycling management plan.

**Vendor and volunteer education and training:** Describe your plans for educating volunteers about waste and recycling management plans at the event, and vendors on what materials will be permitted in order to comply with the Plan and to minimize waste through both reduction and recycling.

**Materials and supplies:** List the materials you plan to have on hand to implement the waste and recycling management plan, including bins, labels, bags, signage, etc.

**Designation of duties:** Clearly designate the volunteers, staff, or other individuals who will be responsible for implementing each component of the waste and recycling management plan.

Google Maps

Barricade placement

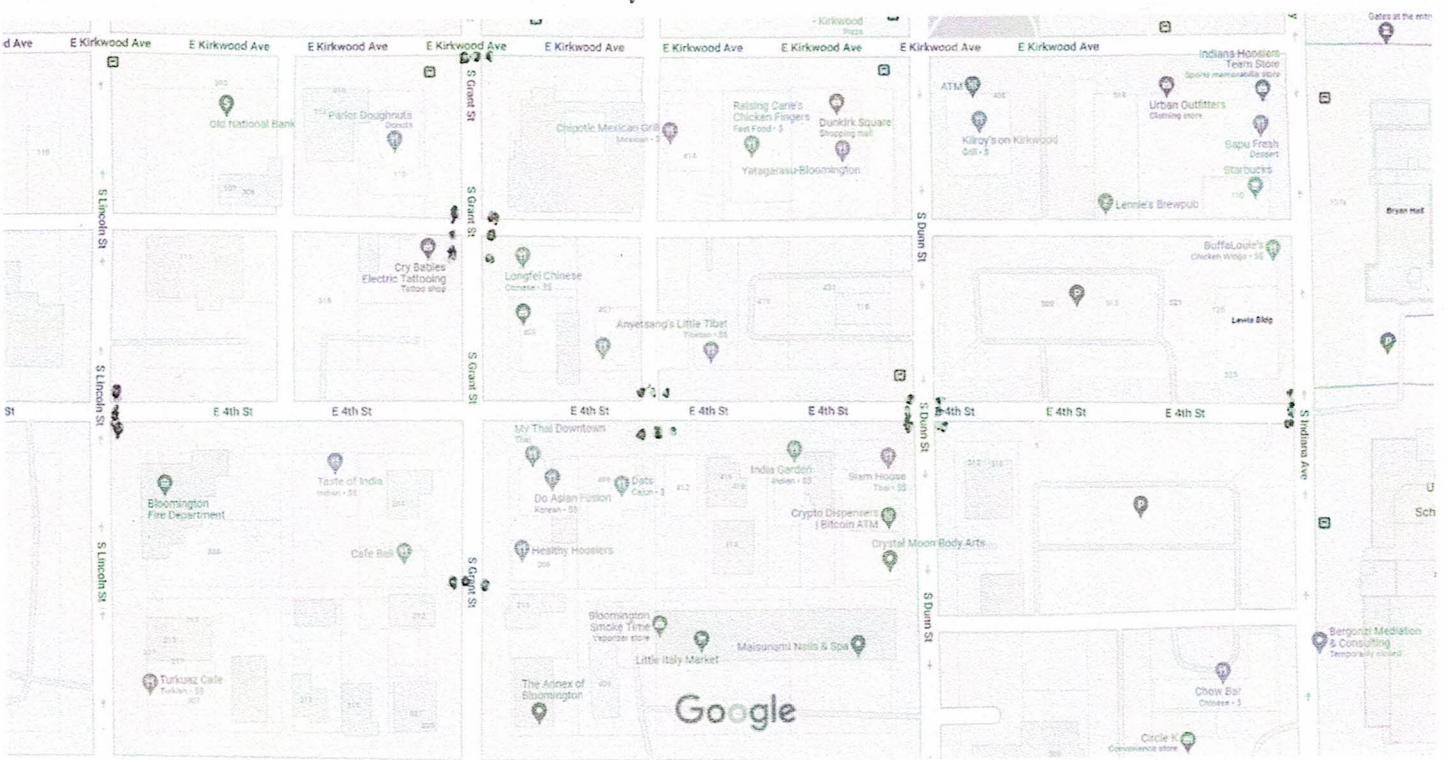

Map data ©2023 Google 50 ft

--- water barricade



# Traffic plan

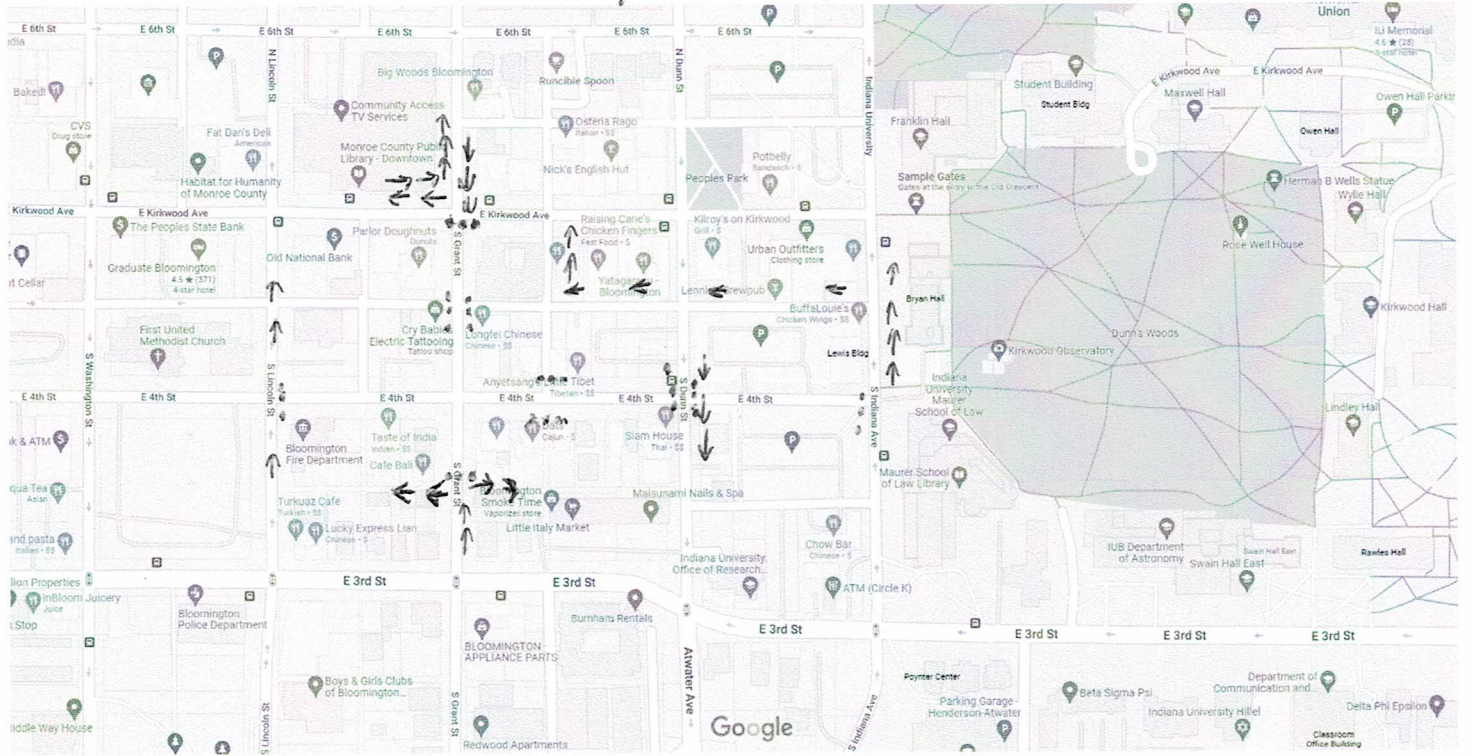

↑ - traffic flow

ooo - water barricades

## NOTICE OF PUBLIC MEETING LETTER

The Board of Public Works of Bloomington, Indiana, has been petitioned to hear a request for a Special Event in Public Right Way for 4<sup>th</sup> St Festival Of The Arts And Crafts

The Board of Public Works meeting to hear this request will be January 31st, 2023. Board of Public Works meetings are held in the Council Chambers of the Showers Center City Hall at 401 N. Morton at 5:30 P.m.

The proposal for 4<sup>th</sup> Festival Of The Arts And Crafts will be on file and may be examined in the Public Works office on the Friday (01/27/2023) prior to the Tuesday (01/31/2023) meeting.

All persons interested in said proposal may be heard at the time and place as herein set out. If you would rather voice your opinion by phone you may call 812.349.3410 or email [public.works@bloomington.in.gov](mailto:public.works@bloomington.in.gov). Written and verbal objections filed with the Board of Public Works prior to the hearing will be considered.

BOARD OF PUBLIC WORKS  
CITY OF BLOOMINGTON, INDIANA

PETITIONER:

Brenden King

DATE: 01/23/2023

# **EMERGENCY ACTION PLAN: FOURTH STREET FESTIVAL**

- I. Purpose
- II. General Procedures III.  
Emergency Alarms IV.

## Evacuation Sites

- V. Procedure for Emergency Shutdown of Operations
- VI. Conditions Warranting Shutdown of Operations

## I. Purpose

The Purpose of the Emergency Action Plan is to protect all participants within the event area from serious injury, property loss, or loss of life in the event of a major disaster. Potential major disasters include: tornado, thunderstorms, fire, flooding, earthquake, bomb threat, hazardous chemical spill or civil violence.

## **IF AN EMERGENCY EXISTS, CALL 911**

## II. General Procedures

In the event of a disaster, the warning may come from any one of the following sources: Commercial radio or television, civil defense warning sirens, Bloomington Police Department or Bloomington Fire Department.

### 1. Notification of Emergency Warning

Any person receiving notification of a possible disaster should notify the Bloomington Police Department, Bloomington Fire Department or Event organizers: (Brenden King (information booth, 765-490-1714), Juliet Roberts (information booth, 812-345-1531))

### 2. Emergency Control Committee

Event organizers Brenden King and Juliet Roberts are the **Emergency Committee** that assesses the severity of the situation.

- a. Bloomington Police Department has ultimate control of any emergency.
- b. Continue the evacuation while in contact with Bloomington Police Department and Show Block Captains.
- c. Assess conditions to continue evacuation

### 3. First Aid Services

- a. First Aid Kit located at the info booth (corner of 4th and Grant)
- b. For additional first aid response, anyone may call 911



4. Missing Children

- a. Missing children and parents should go to the information booth located at 4th and Grant Streets.

5. Event Resumption

- a. Show organizers will walk the event and disseminate information

III. Emergency Alarms

Area evacuation will be announced by the Bloomington Police Department or Bloomington Fire Department or civic warning sirens followed by announcements from the show organizers.

IV. Evacuation Sites

A list of evacuation sites shall be posted at the information booth at the corner of 4th and Grant Streets and at your Block Captain's booth.

These sites will include:

Monroe County Public Library, 303 East Kirkwood Ave 812-349-3050

Any available structurally secure building nearby

V. Procedure for Emergency Shutdown of Operations

An emergency shutdown of operations will be ordered by the Bloomington Police Department or Bloomington Fire Department or Brenden King/Juliet Roberts

VI. Conditions Warranting Shutdown of Operations

- Lightning if sited close
- Wind if too much for tents
- Tornado
- Earthquake
- Fire
- Civil Disturbance
- Bomb Threat
- Hazardous Chemical Spill
- Any other condition deemed necessary by the Bloomington Police

**CALL 911**

Summary:

IF YOU SEE PROBABLE CAUSE TO CEASE OPERATIONS, CONTACT BRENDEN KING 765-490-174 OR JULIET ROBERTS 812-345-1531 OR THE BLOOMINGTON POLICE DEPARTMENT 812-339-4477.

**IF ANY EMERGENCY EXISTS, CALL 911**

**Designated waste and recycling manager: Brenden King**

Event Map: Map and photos attached

**Targeted Waste:**

Food Waste/containers - trash barrels

Plastic beverage bottles and cans - recycling containers

Mixed paper - recycling containers

**Collection and hauling system:**

**Pre-festival Friday**

Engineering dept. will lend sanitation 2 barricades.

Early morning, sanitation will barricade 2 parking spaces in the NW corner of City Lot #1 at 4th and Dunn. (behind Falafel) 20 trash barrels and 10 recycling units will be delivered.

Friday evening, barrels will be placed across festival site by Robert Chambers, whom we hire every year from the sanitation dept (off duty).

**Festival Saturday**

During festival hours Robert Chambers will circulate and collect bags and place bags in barricaded area.

**Festival Sunday**

By 10am sanitation will pick up bags collected from Saturday.

Sunday's bags will go into barricaded area.

As festival ends at 5pm, all cans and recycling units to be returned to barricaded area by Robert Chambers.

Final site walk performed about 7pm by Susan Hingle, Board President and Brenden King Executive Director. Any additional pickup needed is done.

**Monday after festival**

Early morning, sanitation will collect all bags, barrels, and recycling units from barricaded area and return barricades to engineering.

Site visit by Susan Hingle and Brenden King to make sure no evidence of the festival is visible.

**Vendor and volunteer education and training:**

All volunteers are given an overview of where trash and recycling containers are and they are typically all over the site and thus, are able to direct patrons if needed. Waste is greatly minimized by having CBI-J on site at the fire station with their water stand.

**Materials and supplies:**

Sanitation provides us with all barrels and recycling containers. All containers are labeled trash or recycling. 4th Street buys several cases of large bags annually to replace bags throughout the weekend.

**Designation of duties:**

Brenden King works with the sanitation dept and 4th St volunteer coordinator to implement the plan.

Art Depiction:

Art of varying mediums and sizes will be sold by vendors at individual booths. Vendor booths containing said art, will be located along Fourth St and Grant St in our designated footprint. All art sold by vendors will be contained in the vendor's ten by ten square foot booth.



## Board of Public Works Staff Report

**Project/Event:** Second Year Extension of ParkMobile Agreement

**Petitioner:** ParkMobile

**Staff Representative:** Michelle L. Wahl, Parking Service Director

**Meeting Date:** 01/31/2023

Attach is the first year extension agreement for the 2019 ParkMobile agreement. The extension continue to allow consumers to purchase parking meter time through ParkMobile's app at no cost to the City of Bloomington. All parking and convenience fees are paid for by the user of the app.

The second extension request of this agreement will expire on January 21, 2024.

Thank you for consideration of this extension,  
Michelle L. Wahl, CAPP, Parking Service Director

# City of Bloomington Contract and Purchase Justification Form

Vendor:

Contract Amount:

This form should be completed and attached to the contract documents and forwarded to the Legal Department Attorney assigned to your Department. Contracts will not be approved by the Controller if a completed form is not included with the contract documents.

## PURCHASE INFORMATION

1. Check the box beside the procurement method used to initiate this procurement: (Attach a quote or bid tabulation if applicable)

Request for Quote (RFQ)	Request for Proposal (RFP)	Sole Source	Not Applicable (NA)
Invitation to Bid (ITB)	Request for Qualifications (RFQu)	Emergency Purchase	

2. List the results of procurement process. Give further explanation where requested. Yes No

# of Submittals:	Yes	No	Was the lowest cost selected? (If no, please state below why it was not.)
Met city requirements?			
Met item or need requirements?			
Was an evaluation team used?			
Was scoring grid used?			
Were vendor presentations requested?			

3. State why this vendor was selected to receive the award and contract:

\_\_\_\_\_  
Print/Type Name

\_\_\_\_\_  
Print/Type Title

\_\_\_\_\_  
Department



## Second Contract Extension Agreement

This Second Contract Extension Agreement to the Parking Services Agreement (this "Second Extension") is made by and between Parkmobile, LLC, a Delaware limited liability company, with offices at 1100 Spring St. NW, Ste 200, Atlanta, GA 30309 ("ParkMobile") and City of Bloomington, an Indiana municipality by and through its Board of Public Works, with offices at 401 N. Morton St., Suite 120, Bloomington, IN 47404 ("Client"). This Agreement will become effective as of the last signature date below (the "Second Extension Effective Date").

**WHEREAS**, ParkMobile and Client entered into a Parking Services Agreement dated January 21, 2023 (the "Agreement"); and

**WHEREAS**, ParkMobile and Client agreed to extend the Agreement pursuant to that certain First Contract Extension Agreement dated February 8, 2022; and

**WHEREAS**, ParkMobile and Client desire to again extend the term of the Agreement in accordance with its terms; and

**NOW THEREFORE**, in consideration of the mutual covenants and agreements contained herein and other good and valuable consideration, the receipt and sufficiency of which are hereby acknowledged, the Parties agree as follows:

1. Recitals. The above recitals are hereby incorporated herein.
2. Extension. Pursuant to Section 4.1 of the Agreement, the Parties agree to extend the Agreement for a one-year renewal term ending on January 21, 2024.
3. Counterparts. This Second Extension may be executed in counterparts, each of which shall be deemed an original, but all of which shall be deemed to constitute one and the same instrument.
4. Entire Agreement. This Second Extension contains the entire agreement of the Parties with respect to the matters set forth herein and may only be changed by an agreement in writing signed by the Parties. All other terms and provisions of the Agreement remain in full force and affect.

**IN WITNESS WHEREOF**, this Second Extension to the Parking Services Agreement has been executed as of the Second Extension Effective Date.

**CITY OF BLOOMINGTON**

**PARKMOBILE, LLC**

By: \_\_\_\_\_

By: \_\_\_\_\_

Name:

Name:

Title:

Title:

Date:

Date:



This First Contract Extension Agreement ("First Extension") is by and between Parkmobile, LLC, a Delaware limited liability company ("ParkMobile") and City of Bloomington Indiana, a municipal corporation by and through its Board of Public Works ("Board"). ParkMobile and Board may be referred to collectively as the "Parties" or individually as a "Party." This First Extension will become effective as of the last signature date below ("Effective Date")

WHEREAS, the Parties entered into a Parking Services Agreement dated January 21, 2019 (the "Original Contract"); and

WHEREAS, the Parties agree to extend the term of the Original Contract in accordance with the terms of the Original Contract;

NOW THEREFORE, in consideration of the mutual covenants and agreements contained herein and other good and valuable consideration, the receipt and sufficiency of which are hereby acknowledged, the Parties hereto agree as follows:

1. Extension. Pursuant to Section 4.1 of the Original Contract, the Parties agree to extend the Original Contract for a one-year renewal term ending on January 21, 2023. The Parties may continue to exercise their right under the Original Contract to extend the Original Contract for one additional one (1) year renewal terms by written agreement.
2. Counterparts. This First Extension may be executed in counterparts, each of which shall be deemed an original, but all of which shall be deemed to constitute one and the same instrument.
3. Entire Agreement. This First Extension contains the entire agreement of the Parties with respect to the matters set forth herein and may only be changed by an agreement in writing signed by the Parties. All other terms and provisions of the Original Agreement remain in full force and affect.

IN WITNESS WHEREOF, this First Extension to the Parking Services Agreement has been executed as of the Effective Date.

CITY OF BLOOMINGTON, INDIANA

By: Kyla Cox Deckard

Name: KYLA COX DECKARD  
Title: PRESIDENT, BOARD OF PUBLIC WORKS  
Date: 2.1.22

PARKMOBILE, LLC

By: Tony Stewart

Name: Tony Stewart  
Title: Chief Legal Officer  
Date: 2/8/2022



## PARKING SERVICES AGREEMENT

THIS PARKING SERVICES AGREEMENT (this "Agreement") is made and entered into as of this 21st day of January, 2019 (the "Effective Date"), by and among PARKMOBILE, LLC, a Delaware limited liability company ("Parkmobile"), and CITY OF BLOOMINGTON INDIANA, a municipal corporation by and through its Board of Public Works (hereinafter referred to as "BOARD")

### RECITALS:

WHEREAS, Parkmobile is engaged in the business of providing integrated solutions for the management of all parking-related matters, including providing a system for the payment of on-street and off-street parking through proprietary mobile applications; and

WHEREAS, Parkmobile and BOARD desire to enter into a mutually beneficial arrangement, pursuant to which Parkmobile will market through Parkmobile Applications, Sites and other Parkmobile owned or controlled assets, mobile parking services to BOARD, upon the terms and subject to the conditions contained herein rates.

NOW, THEREFORE, in consideration of the terms, conditions, covenants and agreements contained herein, and other good and valuable consideration, the receipt and sufficiency of which are hereby acknowledged by the parties hereto, and in order to effectuate the above arrangement, the parties hereto agree as follows:

### ARTICLE I DEFINITIONS

Except as otherwise specifically indicated in this Agreement, the following terms have the following meanings in this Agreement (such meanings to be applicable equally to the singular and plural forms of the terms defined):

1.1 "Application" means Parkmobile's proprietary mobile applications, websites and other properties as Parkmobile may develop for the purpose of, among other things, scheduling, starting, extending and completing Transactions and making payment for all related charges and fees, including but not limited to on-street and off-street parking, etc.

1.2 "IVR System" means our interactive voice response system.

1.3 "Law" means any applicable law, regulation, legal or regulatory process of any government agency, rule or regulation, or official interpretation thereof that governs or relates to this Agreement, the Services, the Platform or the parties' respective businesses.

1.4 "Minimum Reporting Elements" means the information and data related to the Transactions as described in Schedule 4 attached to this Agreement.

1.5 "Transaction" means a Member's purchase through the Platform of the right to use a parking space, charging station, or other service for a certain period of time.

1.6 "Parking Fee" means, for each Transaction, the amount set by BOARD for a given Transaction.

1.7 "PI" Personal Information means, information that can be used on its own or with other information to identify, contact, or locate a single individual.

1.8 "Platform" means our Application; Services; Site; IVR System; our backend technologies, functions, servers, databases; parking management systems; and our other products, services, content,

features, technologies, functions, applications, and related websites or other applications; and any future updates, changes, revisions or additions thereto, that are related to the management of Transactions.

1.9 "Report" means a detailed statement of information related to the Transactions, as more particularly described in Schedule 2 to this Agreement.

1.10 "Member Fee" means the fees applicable to the Services, as set forth on Schedule 3. Schedule 3 may be updated from time to time in writing upon the mutual agreement of the parties to reflect any changes or modifications in the Fees payable hereunder.

1.11 "Services" means the provision of solutions and resources to market, sell, process, track, redeem, and manage Transactions, as further defined in Schedule 1.

1.12 "Site" means any website owned or controlled by Parkmobile.

1.13 "Total Price" means the total amount to be charged to the Member for each type of Transaction, including the Parking Fee and any Member Fee or other fees which may be charged in accordance with Schedule 3.

1.14 "Transaction" means a Member's purchase through the Platform of the right to use a parking space, charging station, or other service for a certain period of time.

1.15 "Transaction Data" means all data other than Member Data related to a Member's parking session, including, time, Total Price, rate paid and other information related to the parking transaction.

1.16 "Member" means the individual end user using the Platform other than BOARD.

1.17 "Member Data" means all data collected from Members in the process of registering Members and in connection with their usage of the Platform.

1.18 "Net Parking Revenue" means the Total Price generated by Members, less Member Fees charged by Parkmobile, Transaction Processing Fee, bank transfer and other third-party fees.

1.19 "Transaction Processing Fee" means merchant processing and gateway fees at \$.15 plus 3% per authorized Transaction.

1.20 "Emerging Payment Revenue" means the Total Price by Members less Member Fees charged by Parkmobile, Transaction Processing Fees, bank transfer and other third-party fees if applicable.

1.21 "Parking Service Agreement" means our document entitled "Service Agreement" or other document bearing a similar title, or may refer to any similar document setting forth the applicable pricing, Service description, and additional terms and conditions which is executed or otherwise acknowledged by Board in writing and, in any case, also includes all current and subsequent amendments, modifications or supplements thereto as such are implemented from time to time upon the written agreement of the parties. Parking Service Agreements include, but are not limited to a RSA (Reservations Service Agreement), PSA (Permit Service Agreement), or ODSA (On Demand Service Agreement). All Parking Service Agreements incorporate fully these Terms (as amended from time to time) without limitation, restriction, or qualification.

## ARTICLE 2 SERVICES

2.1 Services Provided by Parkmobile. During the Term (as defined herein), Parkmobile shall direct its personnel to perform the services for BOARD as described on Schedule 1 hereof (as amended,

modified or supplemented from time to time upon the mutual written agreement of the parties, the "Services"). Parkmobile shall render the Services faithfully and to the best of its ability and in compliance with all applicable law, regulation, legal or regulatory process or government agency, rules or regulations (collectively, "Law"), devoting such time as is reasonably necessary to provide the Services. The precise times and manner of the performance of Services shall be as reasonably requested by BOARD, consistent with a schedule to be reasonably agreed upon from time to time by Parkmobile and BOARD. In connection with Parkmobile's performance of the Services, Parkmobile shall be subject to, and agrees to abide by, such policies, procedures, directions and restrictions as BOARD may reasonably establish from time to time.

If BOARD requires additional work that is not included in this Agreement, Parkmobile and BOARD shall negotiate the additional work, mutually agree on the amount of additional compensation, and memorialize the terms in either a separate written contract or an amendment to this Agreement.

**2.2 Help and Support.** Parkmobile agrees to use its reasonable efforts to assist BOARD with any technical support that BOARD may reasonably require in relation to using the Services. In furtherance of the foregoing, Parkmobile agrees to provide BOARD with preventative maintenance, corrective maintenance, adaptive maintenance and online, on-site and telephone support, in each case to the extent reasonably necessary for Parkmobile to provide the Services pursuant to this Agreement. In the event a party becomes aware of any errors or interruptions in the Services, each party shall notify the other Party.

**2.3 Error Corrections.** In the event of any errors or interruptions in the Services, Parkmobile shall use commercially reasonable efforts to repair or restore that portion of the Services as promptly as possible. Repair may take the form, at the option of Parkmobile, as the case may be, of: (i) corrected software applicable to the Services; (ii) corrected materials in hard copy or electronic form describing the use and operation of the software applicable to the Services, including any manuals and programming tools; (iii) instructions or procedures to bypass the problem until a more permanent correction can be implemented; or (iv) correction/clarification of the functional definition of the Services.

**2.4 No Performance Warranty.** The Services are provided to BOARD "AS IS" with no warranty of any kind. Notwithstanding the foregoing, Parkmobile shall provide the Services in accordance with the service levels set forth on Schedule 2, as the same may be amended from time to time, upon written agreement of the parties.

**2.5 Reservation of Rights.** All rights not expressly granted to BOARD herein are reserved to Parkmobile. All intellectual property rights related to the Services, as well as any additional services, software, technology or systems developed by Parkmobile, belong to Parkmobile.

**2.6 Publicity of Services.** All brochures and promotional materials to be distributed by BOARD in connection with the Services shall be in a form mutually agreed upon by the parties.

**2.7 Cooperation.** Each party shall reasonably cooperate with the other party to permit such party to perform its duties and obligations under this Agreement in a timely manner.

**2.8 Exclusivity.** Parkmobile shall be the exclusive mobile parking service provider for BOARD during the Term of this Agreement.

**2.9 Authority of the Parties.** Each party acknowledges and agrees that it has no authority to act on behalf of the other party other than as set forth in this Agreement or to enter into any contract or to incur any liability on behalf of the other party, except with prior written consent of an authorized officer of such party. Each party covenants that it shall not at any time represent, either orally or in writing, that it

has any right, power or authority with respect to the other party not expressly granted to the other party by such party.

**2.10 Technology Sublicense.** Parkmobile hereby grants BOARD the nonexclusive, non-transferable, non-sub-licensable, revocable right and sublicense to use the proprietary technology that relates to the Services (the "Technology") in connection with the Services. BOARD shall not use the Technology for any use other than in connection with the Services. BOARD acknowledges and agrees that (a) Parkmobile shall be its exclusive source of the Technology for the Term; and (b) all Services obtained by BOARD shall use the Technology as necessary. BOARD has no interest in or right to use the Technology or any improvements thereto or modifications thereof except as set forth herein. In all instances, BOARD's use of the Technology shall inure to Parkmobile's benefit. During the Term or at any time thereafter, BOARD shall not commit, or cause any third party to commit, any act challenging, contesting or impairing or attempting to impair Parkmobile's right, title and interest in and to the Technology or the validity thereof.

### ARTICLE 3 FEES; EXPENSES

**3.1 Fees.** The fees (the "Fees") applicable to the Services, are set forth on Schedule 3. Schedule 3 may be updated from time to time in writing upon the mutual agreement of the parties to reflect any changes or modifications in the Fees payable hereunder. For each Transaction, Parkmobile shall charge the Member the Total Price. If Parkmobile is the Merchant of Record ("MOR"), BOARD shall provide to Parkmobile a BOARD Electronic Funds Authorization Form (Schedule 6), W-9, and copy of a voided check or bank letter with account info ("Distribution Information") prior to remittance. Parkmobile will retain all BOARD funds without penalty until Parkmobile receives distribution information from BOARD. Thereafter, Parkmobile shall remit Net Parking Revenue to BOARD on a monthly basis.

**3.2 Taxes.** Parkmobile's prices do not include sales, use, revenue or excise taxes, and accordingly, in addition to the price specified herein, the amount of any sales, use, excise or other similar tax applicable to the Services provided hereunder shall be paid by BOARD, or, in lieu thereof, BOARD shall provide Parkmobile with a tax exemption certificate issued by the appropriate taxing authority.

**3.3 Billing Disputes.** BOARD shall not be entitled to suspend payment of any disputed invoices. Any disputes must be submitted to Parkmobile in writing and with an explanation of the reason for the dispute. In the event that any payment dispute is resolved in favor of BOARD, Parkmobile shall credit BOARD on the immediately subsequent invoice issued to BOARD.

**3.4 Expenses.** Except as otherwise provided herein, Parkmobile shall not charge BOARD any costs for the integration of its system(s) or for the management of the project and the Services. Parkmobile shall charge BOARD for ordinary, necessary and reasonable third-party costs only on direct cost basis and only after the prior approval of BOARD.

**3.5 Appropriation of Funds.** Notwithstanding any other provision of this Agreement, if funds for the continued fulfillment of this Agreement by the BOARD are at any time not forthcoming or are insufficient, through failure of any entity, including the BOARD itself, to appropriate funds or otherwise, then the BOARD shall have the right to terminate this Agreement without penalty as set forth in Article 4 herein.

**ARTICLE 4**  
**TERM; TERMINATION**

4.1 **Term.** The initial term of this Agreement shall commence as of the Effective Date and terminate on January 21, 2022 (the "Initial Term"). Following the Initial Term, the Agreement may be extended for two (2) consecutive one (1) year renewal terms (each a "Renewal Term"), provided that neither party gives written notice to the other of its intent not to renew this Agreement at least ninety (90) days prior to the expiration of the then-current Renewal Term. The date on which this Agreement is terminated or expires as provided herein is called the "Termination Date," and the period from the Effective Date through the Termination Date is herein called the "Term."

4.2 **Termination for Cause.**

(a) Either party may terminate this Agreement and the rights granted herein if the other party breaches any of the provisions of this Agreement and (i) fails to remedy such breach within forty-five (45) days after receiving written notice thereof, or (ii) provided the breach does not relate to a monetary obligation, fails to (A) commence a good faith action to remedy such breach within five (5) days after receiving written notice thereof, and (B) diligently pursue such action to conclusion.

(b) Should either party (i) make a general assignment for the benefit of creditors; (ii) institute liquidation proceedings or proceedings to be adjudicated as voluntarily bankrupt; (iii) consent to the filing of a petition of bankruptcy against it; (iv) be adjudicated by a court of competent jurisdiction as being bankrupt or insolvent; (v) seek reorganization under any bankruptcy act; (vi) consent to the filing of a petition seeking such reorganization; or (vii) have a decree entered against it by a court of competent jurisdiction appointing a receiver, liquidator, trustee, or assignee in bankruptcy or in an insolvency covering all or substantially all of such party's property or providing for the liquidation or dissolution of such party's property or business affairs; then, in any such event, the other party, at its option and without prior notice, may terminate this Agreement effective immediately.

4.3 **Effect of Termination.**

(a) Upon termination or expiration of this Agreement, (i) each party shall promptly return to the other party or destroy all of such other party's Confidential Information in its possession or control; and (ii) any licenses granted hereunder shall immediately expire unless stated otherwise, and (iii) BOARD shall discontinue all use of the Technology and intellectual property of Parkmobile.

(b) Upon termination or expiration of this Agreement, (i) BOARD shall pay to Parkmobile any portion of the Fees then accrued and properly payable under this Agreement; (ii) BOARD shall promptly return to Parkmobile all materials in its possession provided by Parkmobile or otherwise created or produced by Parkmobile in connection with the performance of the Services hereunder; and (iii) BOARD shall discontinue all use of the Technology and intellectual property of Parkmobile.

(c) Notwithstanding the exercise by any party of its rights under this Article 4, no termination of this Agreement shall relieve either party of its liability for the payment or performance of any obligation accrued prior to the Termination Date (including any indemnification obligation arising hereunder, whether or not notice of such indemnification claim has been given before such termination, or of any rights or obligations under any other provisions, which, by their meaning or content, are intended to survive the termination hereof).

(d) Notwithstanding the foregoing, the BOARD may terminate or suspend performance of this Agreement at the BOARD's prerogative at any time upon thirty (30) days written notice to Parkmobile. If the BOARD terminates or suspends this Agreement for no cause or convenience,

Parkmobile shall be entitled to its fees for services performed as outlined in Schedule 2 through the date of termination. Parkmobile shall terminate or suspend performance of the Services on a schedule acceptable to the BOARD, and the BOARD shall pay Parkmobile for all the Services performed up to the date that written notice is received, plus reasonable termination or suspension expenses. Upon restart, an equitable adjustment shall be made to Parkmobile's compensation and the schedule of services.

Upon termination or suspension of this Agreement, all finished or unfinished reports, drawings, collection of data and other documents generated by Parkmobile in connection with this Agreement shall become the property of the BOARD, as set forth in Article 5 herein.

## ARTICLE 5 ADDITIONAL COVENANTS OF THE PARTIES

### 5.1 Confidentiality.

(a) Each party (sometimes referred to herein as a "receiving party") acknowledges that all information and trade secrets relating to any of the other party's products and the services hereunder, including, without limitation, pricing, software, business and financial information, marketing and promotion plans, any changes or improvements therein, including any cost savings measures, is the confidential and proprietary information of such other party ("Confidential Information"). Except as otherwise set out herein, neither party shall disclose any Confidential Information of the other party to any third party or use it for its own benefit or the benefit of a third party, and each party shall take all commercially reasonable measures to protect the confidentiality of Confidential Information of the other party and prevent its disclosure to others.

(b) Each receiving party may disclose the Confidential Information of the disclosing party to its affiliates and their respective employees and agents who are directly involved in the performance of this Agreement, who have a need to know and who are obligated to honor the restrictions on disclosure and use of such Confidential Information set forth in this Agreement (the persons to whom such disclosure is permissible being collectively known as "Representatives"). Each party shall be responsible for any breach of this Article 5.1 by its Representatives. The parties shall not disclose, without the prior written consent of the disclosing party, any of such disclosing party's Confidential Information that it has learned either during the course of this Agreement or in discussions and proposals leading up to this Agreement, except as may be required by Law. The parties shall not use the Confidential Information of a disclosing party for any purpose other than that for which it was disclosed.

(c) Each Party's Confidential Information shall remain the property of each respective party. Upon any termination or expiration of this Agreement, each party shall return to the other party the other party's original version of all Confidential Information of such other party in document form, including any electronic media version, such as CD-ROM or computer disk, and shall confirm to such other party in writing that all such documents and things have been so provided and that all copies thereof have been destroyed subject to compliance with applicable Law. The term "Confidential Information" shall not apply to: (i) any information that is or becomes available in the public domain without breach of this Agreement; (ii) information that a party can demonstrate was known prior to receipt from the other party; or (iii) information that was subsequently received from a third party

(d) To the extent any receiving party determines it necessary or advisable to (i) file a copy of this Agreement with a governmental agency including the United States Securities and Exchange Commission, or (ii) make disclosure of Confidential Information of the disclosing party pursuant to a court order or otherwise in accordance with Law, the receiving party and/or its legal counsel shall (a) provide prompt written notice of such expected impending filing or disclosure to the disclosing party, (b) use

reasonable best efforts and work with the disclosing party and its counsel to obtain confidential treatment of relevant portions of this Agreement, including, without limitation, product and service specifications and pricing information prior to any such filing or disclosure and (c) disclose in such filing or disclosure only what is required by Law or judicial process as to both manner and content.

(e) Each party agrees that irreparable damage would occur, and that monetary damages would be an insufficient remedy at law, in the event that any of the provisions of this Article 5.1 were not performed by the other party in accordance with the terms hereof and that each party shall be entitled to specific performance of the terms hereof, in addition to any other remedy at law or equity.

(f) Each party's obligation with respect to the Confidential Information of a disclosing party shall expire three (3) years after the termination or expiration of this Agreement; provided, however, that each party's obligations with respect to the trade secrets of a disclosing party shall remain in effect throughout the Term and at all times thereafter, but only for so long as such information remains a trade secret.

**5.2 Information.** Subject to Article 5.1 and any applicable Laws and privileges, each party covenants and shall provide the other party with all information regarding itself and the transactions under this Agreement that the other party reasonably believes is required to comply with all applicable Law and to satisfy the requesting party's obligations hereunder. Any information owned by one party that is provided to any other party pursuant to this Agreement shall remain the property of the providing party. Unless specifically set forth herein, nothing contained in this Agreement shall be construed as granting or conferring rights of license or otherwise in any such information.

**5.3 Records.** Each party shall maintain and retain records related to the provision of the Services under this Agreement consistent with such party's legal policies regarding retention of records. As needed from time to time during the period in which Services are provided, and upon termination of the provision of any Service, unless otherwise prohibited by applicable Law, the parties shall provide each other with records related to the provision of the Services under this Agreement to the extent that (a) such records exist in the ordinary course of business, and (b) such records are reasonably necessary for the requesting party to comply with its obligations under this Agreement or applicable Law.

**5.4 Status Meetings.** On a periodic basis, an appropriate representative of each party shall conduct a joint meeting to discuss the status of the Services, as well as to answer questions, gather information and resolve disputes that may occur from time to time. It is the expectation of the parties that the representatives of the parties shall communicate directly with one another and work directly with one another to ensure that all Services provided hereunder are completed on a timely and complete basis. All meetings pursuant to this Article 5.4 may be face to face, video or telephonic meetings as may be agreed upon by the parties. Each party shall bear its own costs of attending or participating in such meetings.

**5.5 Privacy.** BOARD agrees (a) to comply with all applicable Law; (b) that it will use reasonable security measures to safeguard the Personal Information ("PI"); and (c) not to disclose to others the PI.

**5.6 Insurance.** Parkmobile shall keep all of its insurable properties adequately insured against losses, damages and hazards as are customarily insured against by businesses engaging in similar activities or owning similar properties and at least the minimum amount required by applicable Law and any other agreement to which Parkmobile is a party or pursuant to which Parkmobile provides any services, including liability, property and business interruption insurance, as applicable. Parkmobile agrees to add Client as an additional insured pursuant to Schedule 6 of this Agreement.



**5.7 Ownership of Intellectual Property.** BOARD acknowledge and agree that Parkmobile or its licensors or providers are the owners of all right, title and interest in and to the Platform, Member Data, all websites owned by Parkmobile, all work product or deliverables, Parkmobile's Intellectual Property and all appurtenant patent, copyright, trademark, trade secret and other intellectual property rights associated with the foregoing. To the extent Parkmobile provides any work product or deliverable to BOARD for BOARD's direct use (e.g. material for inclusion on a BOARD-hosted website to direct Members to a Parkmobile Website or Reservation Demand Management System), BOARD is hereby granted a limited, revocable and personal right to use such work product or deliverable during the Term in accordance with any instructions Parkmobile provides. The provision of any such work product or deliverable to BOARD does not constitute a sale of such work product or deliverable to BOARD. BOARD shall not assign, sublicense, transfer, pledge, lease, rent or share any rights under the foregoing license to any third party unless expressly permitted in writing by Parkmobile. BOARD further agree that all work product or deliverable shall be treated as our Confidential Information. For the avoidance of doubt, any work product or deliverable that is created or used by Parkmobile as part of providing the Services (e.g., a landing page for BOARD hosted by Parkmobile) shall not be subject to the foregoing license.

#### **ARTICLE 6 REPRESENTATIONS AND WARRANTIES; INDEMNIFICATION**

**6.1 Representations and Warranties.** Parkmobile and BOARD hereby represent, warrant and covenant to the other party hereto as follows:

(a) It is duly organized and validly existing under the laws of the state of its incorporation and has full power and authority to carry on its business as it is now being conducted and to own and operate its properties and assets;

(b) The execution, delivery and performance of this Agreement by such party has been duly authorized by all requisite corporate or limited liability company action, as applicable;

(c) It has the power and authority to execute and deliver this Agreement and to perform its obligations hereunder; and

(d) The execution, delivery and performance by it of this Agreement and its compliance with the terms and provisions hereof do not and will not conflict with or result in a breach of any of the terms or provisions of or constitute a default under the provisions of its charter documents or bylaws, or any order, writ, injunction or decree of any court or governmental authority entered against it or by which any of its property is bound.

**6.2 Disclaimer of Warranties.** THE SERVICES ARE PROVIDED "AS IS" AND WITH ALL FAULTS. BOARD ACKNOWLEDGES AND AGREES THAT PARKMOBILE SHALL NOT BE LIABLE FOR ANY ERROR, OMISSION, DEFECT, DEFICIENCY OR NONCONFORMITY IN THE SERVICES. WITHOUT LIMITING THE FOREGOING, BOARD ASSUMES ALL RISKS ASSOCIATED WITH THE SERVICES, OTHER THAN AS SPECIFICALLY SET FORTH HEREIN, NEITHER OF THE PARTIES MAKES ANY REPRESENTATIONS, WARRANTIES OR GUARANTEES, EXPRESS OR IMPLIED, DIRECTLY OR INDIRECTLY, INCLUDING, WITHOUT LIMITATION, ANY WARRANTY OF CONDITION, MERCHANTABILITY OR FITNESS FOR A PARTICULAR PURPOSE OR USE, WITH RESPECT TO, ARISING OUT OF, OR IN CONNECTION

WITH THE SERVICES TO BE PERFORMED HEREUNDER BY SUCH PARTY OR THE RESULTS OBTAINED THEREBY.

**6.3 Indemnification.**

(a) Indemnification by Parkmobile. Parkmobile shall indemnify, defend and hold harmless BOARD, its affiliates, their respective successors and assigns, and their respective officers, directors, employees, consultants, agents and representatives from any liability, damage, diminution in value, loss, cost, claim or expense, including reasonable attorneys' fees and expenses that result from or arise out of: (i) the breach or inaccuracy of any of Parkmobile's representations or warranties in this Agreement; (ii) the breach of any of Parkmobile's covenants or agreements in this Agreement; or (iii) any violations of Law by Parkmobile in performing its obligations in connection with this Agreement.

(b) Indemnification by BOARD. BOARD shall indemnify, defend and hold harmless Parkmobile, its affiliates, their respective successors and assigns, and their respective officers, directors, employees, consultants, agents and representatives from any liability, damage, diminution in value, loss, cost, claim or expense, including reasonable attorneys' fees and expenses that result from or arise out of: (i) the breach or inaccuracy of any of BOARD's representations or warranties in this Agreement; (ii) the breach of any of BOARD's covenants or agreements in this Agreement; or (iii) any violations of Law or governmental rules or regulations by BOARD in performing its obligations in connection with this Agreement.

**6.4 Limitation of Liability.** TO THE FULLEST EXTENT PERMITTED BY LAW, THE AGGREGATE LIABILITY OF PARKMOBILE FOR ANY AND ALL LOSSES AND DAMAGES ARISING OUT OF ANY CAUSE WHATSOEVER (WHETHER SUCH CAUSE BE BASED IN CONTRACT, NEGLIGENCE, STRICT LIABILITY, OTHER TORT OR OTHERWISE) UNDER THIS AGREEMENT SHALL IN NO EVENT EXCEED AN AMOUNT EQUAL TO THE TOTAL AMOUNT PAID FOR THE SERVICES PURCHASED HEREUNDER. EACH PARTY HERETO AGREES THAT EACH OTHER PARTY SHALL NOT BE LIABLE TO SUCH PARTY OR ANYONE ACTING THROUGH SUCH PARTY UNDER ANY LEGAL THEORY (INCLUDING, WITHOUT LIMITATION, BREACH OF CONTRACT, STRICT LIABILITY, NEGLIGENCE OR ANY OTHER LEGAL THEORY) FOR INCIDENTAL, CONSEQUENTIAL, INDIRECT, SPECIAL OR EXEMPLARY DAMAGES ARISING OUT OF OR RELATING TO THIS AGREEMENT.

**ARTICLE 7  
MISCELLANEOUS**

**7.1 Force Majeure.** Neither party shall be liable for failure or delay in performance of its obligations under this Agreement to the extent such failure or delay is caused by an act of God, act of a public enemy, war or national emergency, rebellion, insurrection, riot, epidemic, quarantine restriction, fire, flood, explosion, storm, earthquake, interruption in the supply of electricity, power or energy, terrorist attack, labor dispute or disruption, or other event beyond the reasonable control of such party and without the fault of or negligence by such party (each, a "Force Majeure Event"). If a party's performance under this Agreement is affected by a Force Majeure Event, such party shall give prompt written notice of such event to the other party, stating the date and extent of such suspension and the cause thereof, and shall at all times use commercially reasonable efforts to mitigate the impact of the Force Majeure Event on its performance under this Agreement; provided, that such party shall take measures to overcome the condition that are consistent in all material respects with the measures taken in connection with such party's business. The parties shall promptly confer, in good faith, on what action may be taken to minimize the impact, on both parties, of such condition. In the event of a Force Majeure Event that affects either or both parties'

ability to perform under this Agreement, the parties agree to cooperate in good faith to resume the affected services as soon as commercially possible to the extent commercially reasonable.

**7.2 Notices.** All notices, requests, claims, demands and other communications hereunder shall be in writing and shall be deemed to have been duly given when delivered (a) in person; (b) by any national overnight courier or other service providing evidence of delivery, or by registered or certified mail (postage prepaid, return receipt requested); or (c) by facsimile with a copy delivered the next business day by any overnight courier or other service providing evidence of delivery, to the respective parties at the following addresses:

To Parkmobile: Parkmobile, LLC  
1100 Spring Street NW, Suite 200  
Atlanta, Georgia 30309  
Attention: Jonathan Ziglar  
Telephone: (404) 818-9036  
Facsimile: (770) 818-9039  
Email: [legal@parkmobileglobal.com](mailto:legal@parkmobileglobal.com)

To BOARD: City of Bloomington  
Board of Public Works  
City Hall at Showers  
401 N. Morton Street, Suite 120  
Bloomington, IN 47404  
Attention: Adam Wason  
Telephone: 812-349-3410  
email: [wasona@bloomington.in.gov](mailto:wasona@bloomington.in.gov)  
Fax: 812-349-3567

or to such other address (or fax number, if applicable) as the party to whom notice is given may have previously furnished to the others in writing in the manner set forth above (provided that notice of any change of address or fax number shall be effective only upon receipt thereof).

**7.3 Independent Contractors.** The parties are independent contractors under this Agreement, which shall not be construed to create any employment relationship, partnership, joint venture, franchisor-franchisee or agency relationship that did not already exist prior to the Effective Date, or to authorize any party to enter into any commitment or agreement binding on the other party except as expressly stated herein. The parties have no authority to make statements, warranties, or representations or to create any liabilities on behalf of the other.

**7.4 Entire Agreement.** This Agreement and the documents and schedules referred to herein contain the complete agreement between the parties hereto and supersede any prior understandings, agreements or representations by or between the parties, written or oral, which may have related to the subject matter hereof in any way; provided, however, that this provision is not intended to abrogate any other written agreement between the parties executed with or after this Agreement.

**7.5 Amendment and Waiver.** The parties hereto may not amend or modify this Agreement except as may be agreed upon by a written instrument executed by the parties hereto. No waiver of any provision hereunder or any breach or default thereof shall extend to or affect in any way any other provision or prior or subsequent breach or default.

7.6 Successors and Assigns. This Agreement and all of the provisions hereof shall be binding upon and inure to the benefit of the parties and their respective successors and permitted assigns, except that neither this Agreement nor any of the rights, interests or obligations hereunder may be assigned or delegated by either party without the prior written consent of the other party (which consent shall not be unreasonably withheld); provided that Parkmobile may assign its rights, interests or obligations under this Agreement without the consent of BOARD to (i) any affiliate of Parkmobile or (ii) any lender to Parkmobile or its affiliates as security for borrowings.

7.7 Third-Party Beneficiaries. The parties to this Agreement do not intend this Agreement to benefit or create any right or cause of action in or on behalf of any person or entity other than Parkmobile and BOARD.

7.8 Severability. Whenever possible, each provision of this Agreement shall be interpreted in such manner as to be effective and valid under applicable Law, but if any provision of this Agreement is held to be prohibited by or invalid under applicable Law, such provision shall be ineffective only to the extent of such prohibition or invalidity, without invalidating the remainder of such provision or the remaining provisions of this Agreement.

7.9 Governing Law. This Agreement shall be governed by and construed in accordance with the laws of the State of Indiana, without giving effect to any choice or conflict of law provision or rule that would cause the application of the laws of any other jurisdiction.

7.10 Non-Discrimination. Parkmobile shall comply with City of Bloomington Ordinance 2.21.020 and all other federal, state and local laws and regulations governing non-discrimination in employment.

7.11 Compliance with Laws. In performance the Services under this Agreement, Parkmobile shall comply with any and all applicable federal, state and local statutes, ordinances, plans and regulations, including any and all regulations for protection of the environment. When appropriate, Parkmobile shall advise BOARD of any and all applicable regulations and approvals required by the Federal Environmental Management Agency (FEMA). Where each statutes ordinances, plans or regulations of any public authority having any jurisdiction on the project are in conflict, Parkmobile shall proceed using its best judgment only after attempting to resolve any such conflict between such governmental agencies and shall notify the BOARD in a timely manner of the conflict, attempts of resolution and planned course of action.

7.12 Arbitration. Should there be any ambiguity, contradiction or inconsistency in this Agreement, or should any disagreement or dispute arise between the parties in connection with this Agreement, the component representatives of the parties shall first attempt in good faith amicably to settle the matter by mutual negotiations. If such negotiations are unsuccessful, any controversy, dispute or claim arising out of, or in connection with, this Agreement must be settled by final and binding arbitration to be held exclusively in the State of Indiana in accordance with the Commercial Arbitration Rules, as amended and in effect from time to time, of the American Arbitration Association (the "Rules"). The procedures and law applicable during the arbitration of any controversy, dispute or claim shall be both the Rules and the internal laws of the State of Indiana excluding, and without regard to, its or any other jurisdiction's rules concerning any conflict of laws. The arbitrator shall have the power to order injunctive relief or provide further equitable remedies. All fees and expenses relating to the work performed by the arbitrator(s) shall be shared equally between the parties. Nothing in this paragraph shall prevent a party from seeking injunctive relief from any of the state or federal courts located in the State of Indiana. The parties consent to the exclusive jurisdiction and venue of such courts with respect to any matter not within the arbitrator's jurisdiction. Any award of the arbitrator may be enforced in any court of competent jurisdiction.



**7.13 No Strict Construction: Headings.** The language used in this Agreement shall be deemed to be the language chosen by the parties hereto to express their mutual intent, and no rule of strict construction shall be applied against any party. The headings used in this Agreement are for reference purposes only and shall not affect in any way the meaning or interpretation of this Agreement.

**7.14 Verification of New Employee Employment Status.** Parkmobile is required to enroll in and verify the work eligibility status of all newly-hired employees through the E-verify program. (This is not required if the E-verify program no longer exists.) Parkmobile shall sign an affidavit, attached as Exhibit A, affirming that Parkmobile does not knowingly employ an unauthorized alien. "Unauthorized alien" is defined at U.S. Code 1324(h)(3) as a person who is not a U.S. citizen or U.S. national and is not lawfully admitted for permanent residence or authorized to work in the U.S. under 8 U.S. Code Chapter 12 or by the U.S. Attorney General.

Parkmobile and any subcontractors may not knowingly employ or contract with an unauthorized alien or retain an employee or contract with a person that Parkmobile or subcontractor learns is an unauthorized alien. If the BOARD obtains information that Parkmobile or a subcontractor employs or retains an employee who is an unauthorized alien, the BOARD shall notify Parkmobile or subcontractor of the contract violation and require that the violation be remedied within thirty (30) days of the date of notice. If Parkmobile or a subcontractor verifies the work eligibility status of the employee in question through the E-verify program, there is a rebuttable presumption that Parkmobile or subcontractor did not knowingly employ an unauthorized alien. If Parkmobile or subcontractor fails to remedy the violation within the thirty (30) day period, the BOARD shall terminate the Agreement, unless the BOARD determines that termination the Agreement would be detrimental to the public interest or public property, in which case the BOARD may allow the Agreement to remain in effect until the BOARD procures a new provider. If the BOARD terminates the Agreement, Parkmobile or subcontractor is liable to the BOARD for actual damages.

Parkmobile shall require any subcontractor performing work under this Agreement to certify to Parkmobile that, at the time of certification, the subcontractor does not knowingly employ or contract with an unauthorized alien and the subcontractor has enrolled in and is participating in the E-verify program. Parkmobile shall maintain on file all subcontractors' certifications throughout the term of this Agreement with the BOARD. Exhibit A is attached hereto and incorporated herein by reference as though fully set forth.

**7.15 Counterparts: Delivery.** This Agreement may be executed in any number of counterparts, each of which shall be deemed an original, but all of which together shall constitute but one and the same instrument. The parties agree that this Agreement may be executed and delivered by facsimile or other electronic transmission.

*Signatures on following page*

IN WITNESS WHEREOF, this Parking Services Agreement has been executed as of the day and year first above written.

"PARKMOBILE":

PARKMOBILE, LLC

By: [Signature]  
Name: Jonathan Ziglar MARK VANJARNA  
Title: CEO CFO

"BOARD":

CITY OF BLOOMINGTON, INDIANA

By: [Signature]  
Name: KYLA COX DECKARD  
Title: PRESIDENT, BOARD OF PUBLIC WORKS

CITY OF BLOOMINGTON  
Legal Department  
Reviewed By: BEM  
DATE: 1/15/18

CITY OF BLOOMINGTON  
Controller  
Reviewed by: [Signature]  
DATE: 1-18-18  
FUND/ACCT: NA

## SCHEDULE 1

### SERVICES

Parkmobile offers a service to BOARD's parking customers ("Members") that facilitates the activation and payment of parking transactions using the Application. For use of the Application, a Service Fee per Transaction as reflected in Schedule 3 is charged.

Parkmobile accepts several electronic payment methods from Members:

- a. Traditional credit card payments are accepted with Visa, MasterCard, Discover, & AMEX ("Traditional Payments")
- b. Emerging Payments ("Emerging Payments"). Emerging payments represent the numerous alternative payment methods that have begun to hit the marketplace today. Mostly, these innovations involve the use of virtual account-based membership profiles that a customer can utilize to transact purchases based upon the member's individual payment preferences. Examples of emerging payments include PayPal, Parkmobile's Stored Value Wallet, ACH, MasterPass, and Visa checkout.

Members who are registered with Parkmobile can begin and, if applicable, end a parking transaction in a variety of ways: visiting the website of Parkmobile - [www.parkmobile.com](http://www.parkmobile.com); calling an Intelligent Voice Response (IVR) 1-800 Number, or using Parkmobile's or its partners' mobile applications. In order to register and begin a parking event, Users simply provide the required information to create an account including credit card data and license plate number which is stored in a secure, PCI Level 1 compliant environment. Thereafter, subsequent parking visits only require the Member to enter or select the applicable parking duration options available for the location.

The tariff code of the parking area is indicated on parking signs or on parking meters. Enforcers of the BOARD check the validity of parking status real time against the Parkmobile database via a web service offering, free of charge to the BOARD, to determine if a valid parking right exists. This service can be accessed by using a handheld terminal or PDA.

The supply of handheld terminals (or PDAs) for enforcement and GSM cards for communication between the handheld terminals and the database and back-office systems are outside the scope of the Services.

Members can use Mobile Parking anywhere the Parkmobile mobile payment service is available.

All parking charges are charged to the preferred payment method of the Member. Members have real time access to an online account-based personal page accessible from [www.parkmobile.com](http://www.parkmobile.com) to check and print their parking history, receipts, and statements.

## SCHEDULE 2

### SERVICE LEVELS

#### 1. Operation, Management and Maintenance of the System

(a) Parkmobile shall use its best efforts not to perform maintenance during business hours. In emergency cases, adjustments to the system may also take place during hours for paid parking. If necessary, Parkmobile may perform maintenance of the system during business hours, provided Parkmobile provides BOARD with at least twenty-four (24) hours advance notice before the start of the work.

(b) Parkmobile makes a daily backup of data in the (local) database, which data are retained for three (3) months.

#### 2. Errors and Interruptions

(a) When an error or interruption occurs in the Services, whichever party identifies the error or interruption shall inform the other party as soon as possible. Parkmobile shall confirm its receipt of such notification in writing. If any error or interruption cannot be repaired by Parkmobile within five (5) business days from the date when the error or interruption is reported to Parkmobile, then Parkmobile shall issue a credit for the Services during such downtime. Time spent by Parkmobile to restore and support to interruptions and errors caused by BOARD and not attributable to Parkmobile shall be charged at the hourly rate of \$180.

(b) In the event that BOARD and Parkmobile disagree about whether an error or interruption has been resolved, BOARD and Parkmobile shall discuss in good faith and reach a mutual resolution regarding whether such error or interruption has occurred or been adequately resolved. If the parties agree that the problem was in fact an error or interruption, then BOARD shall not be entitled to a credit for the Software during the downtime.

#### 3. Security and Authorization

Parkmobile shall protect and authenticate a limited number of representatives that shall have access to the system and confidential information. The parties shall respect and utilize security access codes.

#### 4. Reports

- a. In addition to the Minimum Reporting Elements, Parkmobile shall provide BOARD access to several reports related to the Services via a web portal. All reports are available immediately. Those reports include;
- b. Parking Transaction Report: Ad hoc and automated reports that include all information related to parking reservations which can be used for operations and management.
- c. Payment Transaction Report: Ad hoc and automated reports that include payment information necessary for reconciliation.
- d. Daily Summary Reports which include all reservations for the previous date and the current date.

**SCHEDULE 3**

**FEES**

Parkmobile shall charge the Member a member fee as outlined in the following pricing schedule: ("Member Fee").

Item		Member	Preferred Member	Corporate Member (Fleet Accounts)	
1	Standard convenience fee				
		:Wallet*	0.40	0.30	0.30
		:Non Wallet	0.55	0.45	0.45
2	Monthly Membership fee	NO	.99 per Account	.99 per License Plate	
3	Registration Cost:	:Online	No Cost	No Cost	No Cost
		:Mobile App	No Cost	No Cost	No Cost
		:IVR	No Cost	No Cost	No Cost
		:Personal Call Center Service with Live Agent	3.50	3.50	N.A
4	Number of Registered Vehicles	Up to 5	Up to 5	Unlimited	
5	Payment Options Accepted:	:Credit Card (Visa/MC/Discover/AMEX)	YES	YES	YES
		:Debit Card (Visa/MC Logo Curds not ATM Cards)	YES	YES	YES
		:Wallet	YES	YES	YES
		:PayPal	YES	YES	YES
6	Alerts and Reminders:	:Email	YES	YES	YES
		:Push Notifications (iPhone)	YES	YES	YES
		:SMS TXT message	YES	YES	YES

Parkmobile offers a plan for heavy parking customers to opt for a monthly fee of 99 cents in exchange for an addition 10 cents off each parking transaction.

There is no cost associated with the initial funding (load) or additional loads to the End User's wallet account

Traditional Payment Credit Card Fees/Merchant Processing/Other Third-Party Fees:

Parkmobile can pass real time authorized debit/credit card transactions daily in batch format to Parkmobile's preferred payment processor, subsequently funded directly into a Parkmobile-controlled escrow account. In this scenario, Parkmobile acts as the MOR in the arrangement and passes Net Parking Revenues in accordance with Parkmobile's standard settlement procedures to the BOARD.

Emerging Payments Fees

Parkmobile shall collect the Total Price for each Emerging Payment transaction and pass the Emerging Parking Revenue to the BOARD in accordance with Parkmobile's standard settlement procedures.



#### Other Terms and Conditions

Parkmobile's Member Fee does not cover any Transaction Processing Fees or other third-party fees associated with the acceptance of Traditional or Emerging Payments.

Parkmobile reserves the right to pass through increases in third party transaction processing and related fees.

The use of mobile devices for enforcement as well as data plans are not part of this agreement.

Cost for initial standard stickers shall be borne exclusively by Parkmobile. BOARD will be responsible for all installation.

Cost of marketing shall be borne exclusively by Parkmobile based on Parkmobile's standard marketing program. Parkmobile reserves the right to change its name, branding and signage at any time during the Term of this Agreement

Parkmobile reserves the right to increase Member Fees and Additional Service (as defined below) fees upon sixty (60) days written notice to BOARD.

Other development activities and additional services (listed below) for a fee at the request of and after written approval by BOARD as described below.

#### Additional Services:

1. Non-Integrated Gateway Service
2. Additional Marketing/Advertising
3. Customized Reporting
4. Custom Integration to 3<sup>rd</sup> parties
5. Citation/Enforcement support
6. Replacement Signage/Stickers
7. Additional Training
8. Zone & Rate structure changes after implementation
9. Event Override Solution
10. Self-Administration Service

**SCHEDULE 4**

**Minimum Reporting Elements**

- 1) Time/Date when Transaction was completed (with time zone)
- 2) Time/Date range for parking purchased in Transaction (with time zone)
- 3) Total price charged to Member
- 4) Price breakdown
  - (a) Member Fee
  - (b) Parking Fee
- 5) Payment Method - Credit Card, PayPal, Samsung Pay, etc.

**SCHEDULE 5**

**PAYEE/BOARD INFORMATION**

BOARD NAME:
ADDRESS:
CONTACT PERSON:
TELEPHONE NUMBER:
EMAIL:
SIGNATURE & TITLE OF AUTHORIZED OFFICIAL:

**FINANCIAL INSTITUTION INFORMATION**

BANK NAME:
ADDRESS:
CONTACT PERSON:
TELEPHONE:
EMAIL:
NINE DIGIT ROUTING TRANSIT NUMBER:
DEPOSITOR ACCOUNT TITLE:
DEPOSITOR ACCOUNT NUMBER:
TYPE OF ACCOUNT:

This authorizes Parkmobile, LLC to send credit entries (and appropriate debit and adjustment entries), electronically or by any other commercially accepted method, to the account indicated above and to other accounts specified by BOARD in the future (the "Account"). This authorizes the financial institution holding the Account to post all such entries. This authorization will be in effect until Parkmobile receives a written termination notice from Board and has a reasonable opportunity to act on it.

#### SCHEDULE 6

During the performance of any and all Services under this Agreement, Parkmobile shall maintain the following insurance in full force and effect:

- a. General Liability Insurance, with a minimum combined single limit of \$1,000,000 for each occurrence and \$2,000,000 in the aggregate.
- b. Automobile Liability Insurance, with a minimum combined single limit of \$1,000,000 for each person and \$1,000,000 for each accident.
- c. Professional Liability Insurance ("Errors and Omissions Insurance") with a minimum limit of \$1,000,000 annual aggregate.
- d. Workers' Compensation Insurance in accordance with the statutory requirements of Title 22 of the Indiana Code.

All insurance policies shall be issued by an insurance company authorized to issue such insurance in the State of Indiana. The City of Bloomington and the officers, employees and agents thereof shall be named as insureds under the General Liability, Automobile, and Worker's Compensation policies, and such policies shall stipulate that the insurance will operate as primary insurance and that no other insurance of the City's will be called upon to contribute to a loss hereunder.

Parkmobile shall provide evidence of each insurance policy to the City prior to the commencement of work under this Agreement. Approval of the insurance by the City shall not relieve or decrease the extent to which Consultant may be held responsible for payment of damages resulting from Consultant's provision of the Services or its operations under this Agreement. If Consultant fails or refuses to procure or maintain the insurance required by these provisions or fails or refuses to furnish the City's required proof that the insurance has been procured and is in force and paid for, the City shall have the right at its election to terminate the Agreement.

EXHIBIT A

STATE OF Georgia  
COUNTY OF Fulton

AFFIDAVIT REGARDING E-VERIFY

The undersigned, being duly sworn, hereby affirms and says that:

1. The undersigned is the Regulatory & Compliance Officer of Parkmobile, LLC ("Company").
2. The Company named herein that employs the undersigned has contracted with or is seeking to contract with the City of Bloomington to provide services.
3. The undersigned hereby states that, to the best of his/her knowledge and belief, the Company named herein does not knowingly employ an "unauthorized alien", as defined in 8 United States Code 1324a(h)(3).
4. The undersigned hereby states that, to the best of his/her knowledge and belief, the company named herein is enrolled in and participates in the E-verify program.

Alison Ehrlich  
 Signature  
 Alison Ehrlich

STATE OF Georgia  
COUNTY OF Fulton

Before me, a Notary Public in and for Said County and State, personally appeared Alison Ehrlich and acknowledged the execution of the foregoing this 25 day of January, 2018.

Cynthia Dnos  
 Notary Public  
 Printed Name

11/20/20  
 My Commission Expires:  
Fulton  
 County of Residence:

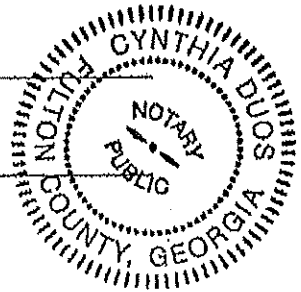





**REGISTER OF PAYROLL CLAIMS**  
**Board: Board of Public Works Claim Register**

Date:	Type of Claim	FUND	Description	Bank Transfer	Amount
1/27/2023	Payroll				520,772.28
					<u>520,772.28</u>

**ALLOWANCE OF CLAIMS**

We have examined the claims listed on the foregoing register of claims, consisting of 1  
claim, and except for the claims not allowed as shown on the register, such claims are hereby allowed in the  
total amount of \$ 520,772.28

**Dated this 31st day of January year of 2023.**

\_\_\_\_\_

Kyla Cox Deckard, President                      Elizabeth Karon, Vice President                      Jennifer Lloyd, Secretary

I hereby certify that each of the above listed voucher(s) or bill(s) is (are) true and correct and I have audited same in accordance with IC 5-11-10-1.6.

Fiscal Officer \_\_\_\_\_



## Board of Public Works Staff Report

---

<b>Project/Event:</b>	Request from Duke Energy for street and lane closures
<b>Staff Representative:</b>	Paul Kehrberg
<b>Petitioner/Representative:</b>	Dawn Brunk, Duke Energy
<b>Date:</b>	January 31, 2023

---

**Report:** Duke Energy is moving to the construction phase Phase 3 of the Reliability Project in Bloomington. The overall project will install new transmission lines to connect the substations at 11<sup>th</sup> and Rogers to the substation on S Rogers St near Switchyard Park. Crews will also be upgrading sections of distribution lines along the route. The work is planned for February 1 to June 30, 2023. It will include lane closures and a few full street closures as crews work through the project area in phases.

Duke Energy has done a lot community outreach in various forms to engage area residents and businesses. City staff will receive weekly progress updates during the project.



1000 East Main Street  
Plainfield, IN 46168

o: 317-838-1142  
c: 317-697-1873

1/30/2023

Board of Public Works  
401 North Morton Street  
Bloomington, IN 47404

Re: Duke Energy Reliability Line Construction

Dear Board Members:

Duke Energy will begin work in February 2023 to begin construction of the new planned transmission line along several downtown streets and along the B-Line Trail. This work is one phase of a multi-year effort known as the Bloomington Reliability Project. Planning for the project began in 2016 to help meet the growing demand for electricity and to adequately serve the city.

The project includes the installation of new power lines that will feed three substations in a 3.3-mile transmission corridor and provide a continuous, enhanced reliable flow of energy for the Bloomington community. The project also:

- Provides additional capacity to deliver reliable electricity to help meet the growing needs of Bloomington and Duke Energy customers
- Provides more options for delivering and managing power in the area, enhancing the integrity of the system
- Improves electrical system reliability
- Better addresses the impact of severe weather in the city by improving the resiliency of the electric system and allowing for quicker recovery of service during storm-related outages
- Maintains a robust system for supplying and delivering electricity, which is integral to help ensure the continued economic growth and prosperity of the city and region
- Improves power quality and reliability now and in the future

Construction for the project has been divided into three phases. Phase 1 was completed in 2019 with the installation of the new 11<sup>th</sup> Street substation and transmission line system along North Rogers Street. Duke Energy is now preparing for Phase 3 to connect the 11<sup>th</sup> Street substation to the substation on South Rogers Street.

The construction work will require temporary lane, road and trail closures from February 1, 2023 to June 30, 2023 as submitted with the Right-Of-Way Use Permit Application. The temporary closures are necessary for safety. The work will be completed in sections to prevent closures along the entire route for the duration of the project. Complete closures will be manned and able to work with local residents and businesses for access. Detour routes and signage will be in place. The barricades will be taken down daily to allow traffic to flow when the work is done, and the road will be cleared for the evening/night. The traffic on one lane closures will be guided by flaggers.

Duke Energy has worked closely with City of Bloomington officials throughout the planning process on all phases of the project. We have also hosted informational community forums to gather input and evaluate options for the new transmission line route to be the least impactful to the community. We have continued to communicate with stakeholders along the route and in the community:

- Project webpage launched in early 2022: [Bloomington Reliability Project – Duke Energy \(duke-energy.com\)](https://www.duke-energy.com/bloomington-reliability-project)
- January 18, 2022: Phase 3 notification letter mailed to property owners and current tenants in the project area
- June 29, 2022: Phase 3 update postcard mailed notifying neighbors that the project schedule has shifted to 2023
- November 14, 2022:
  - Phase 3 - Update postcard mailed to property owners and tenants in the project area notifying them of upcoming work in 2023
  - Phase 2 – Notification letter mailed to property owners and tenants in the project area
- News release to communicate project was released January 4, 2023.



News Release\_Duke  
Energy begins next |

The project will continue to be managed in coordination with Duke Energy and the City of Bloomington. Questions about the project can be directed to Dawn Brunk at [dawn.brunk@duke-energy.com](mailto:dawn.brunk@duke-energy.com).

Sincerely,

A handwritten signature in black ink that reads "Dawn M. Brunk".

Dawn Brunk, Project Manager





1000 East Main Street  
Plainfield, IN 46168

o: 317-838-1142  
c: 317-697-1873

Jan. 30, 2023

Board of Public Works  
401 North Morton Street  
Bloomington, IN 47404

Re: Duke Energy Construction ROW Work

Dear Board Members:

Duke Energy will begin construction of the new planned transmission line in February 2023 along several downtown streets and along the B-Line Trail. This project is part of a multi-year project that began in 2016 to help meet the growing demand for electricity and adequately serve the city. Duke Energy has worked closely with the city and local officials to plan the project

In order to facilitate this project, Duke Energy is respectfully requesting the following:

Temporary closures in the following locations:

- Rogers St from Duke Property to Patterson St.
- North side of Patterson St to Morton St.
- South side of W 4<sup>th</sup> St from east of S Madison St to Rogers St
- East side of S Rogers St and W 4<sup>th</sup> St to N Rogers St and B-Line Trail
- Fairview St from B-Line Trail to 11<sup>th</sup> St.
- 11<sup>th</sup> St from Fairview to Duke Property

Complete road closures in the following locations:

- Morton Street from Patterson Street north to parking lot at end of street
- Madison Street from west side of parking lot north to 4<sup>th</sup> St.

This information is included in the attached Management of Traffic Plan. Duke Energy will coordinate with the City of Bloomington, City of Bloomington Utilities, law enforcement and transit providers to ensure that this restriction and closure information is well communicated. Therefore, Duke Energy respectfully requests that the Board of Public Works approves the restrictions closure referenced above from February 1, 2023 to June 30, 2023.

Sincerely,

Dawn Brunk, Project Manager

**BOND**  
(License or Permit - Continuous)

**Travelers Casualty and Surety Company of America**  
One Tower Square 3PB, Hartford, CT 06183

Bond No. 105534117

KNOW ALL MEN BY THESE PRESENTS:

THAT WE, Duke Energy Indiana, Inc., as Principal, and Travelers Casualty and Surety Company of America, a corporation duly incorporated under the laws of the State of Connecticut and authorized to do business in the State of Connecticut, as Surety, are held and firmly bound unto City of Bloomington, as Obligee, in the penal sum of Ten Thousand and 00/100 (\$10,000.00) Dollars, for the payment of which we hereby bind ourselves, our heirs, executors and administrators, jointly and severally, firmly by these presents.

WHEREAS, the Principal has obtained or is about to obtain a license or permit for Right-of-Way.

NOW, THEREFORE, THE CONDITIONS OF THIS OBLIGATION ARE SUCH, that if the Principal shall faithfully perform all duties and protect said Obligee from any damage caused by the Principal's non-compliance with or breach of any laws, statutes, ordinances, rules or regulations, pertaining to the license or permit issued, then this obligation shall be null and void; otherwise to remain in full force and effect.

This bond shall become effective on the 20th day of July, 2011.

PROVIDED, that regardless of the number of years this bond is in force, the Surety shall not be liable hereunder for a larger amount, in the aggregate, than the penal sum listed above.

PROVIDED FURTHER, that the Surety may terminate its liability hereunder as to future acts of the Principal at any time by giving thirty (30) days written notice of such termination to the Obligee.

SIGNED, SEALED AND DATED this 20th day of July, 2011.

**Duke Energy Indiana**

By: \_\_\_\_\_  
Principal

**Travelers Casualty and Surety Company of America**

By: \_\_\_\_\_  
Elizabeth Marrero, Attorney-in-Fact

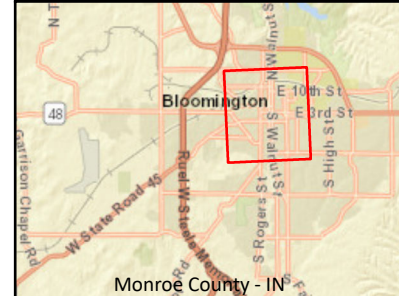
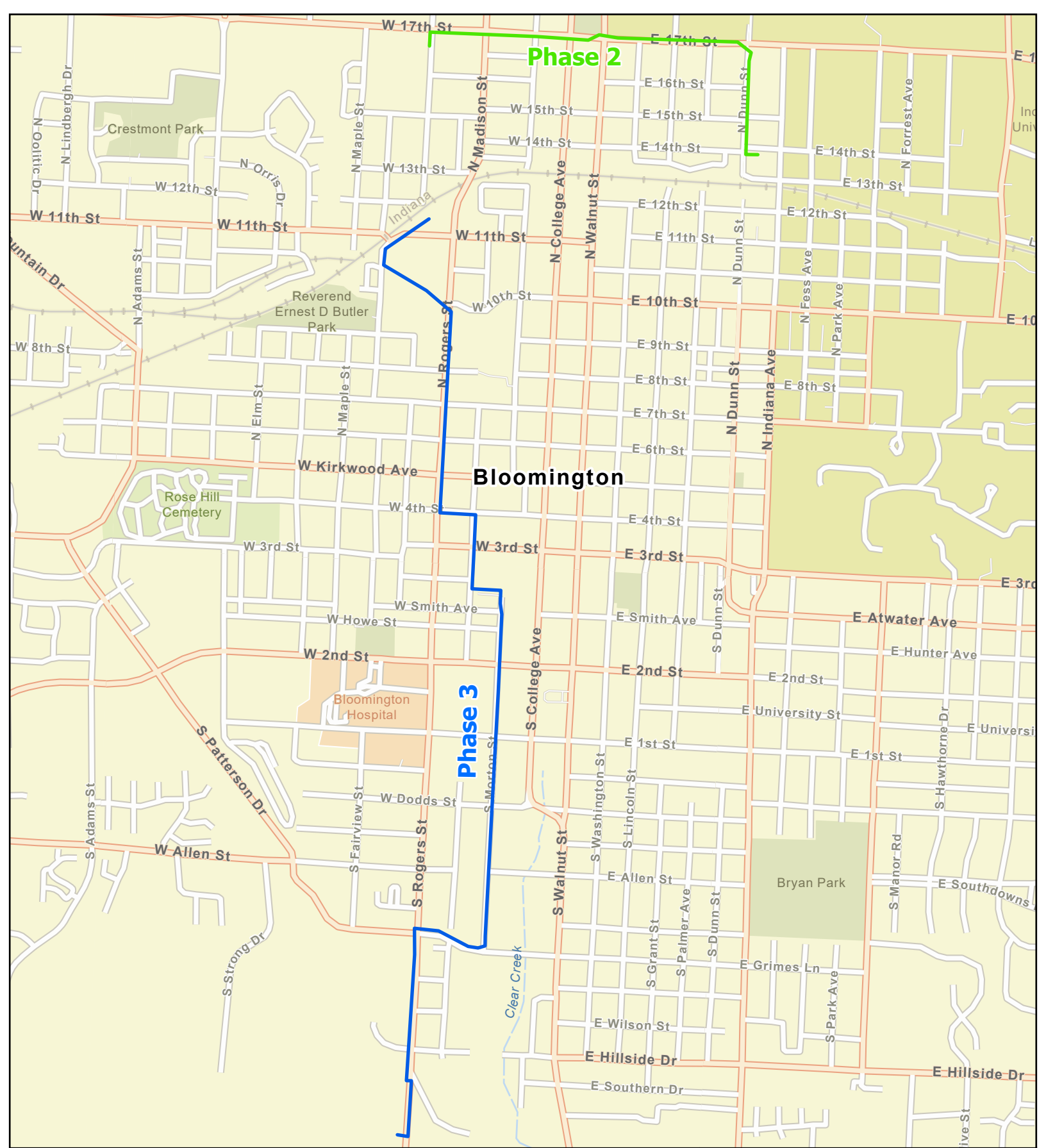

**Key**

- Phase 2 New Transmission Line
- Phase 3 New Transmission Line

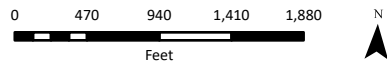

REFERENCE: Basemap: Esri Aerial Imagery Service, Accessed 12/16/2021, Duke Assets: Duke Energy



**Bloomington Rogers Street –  
11th Street – Dunn Street  
Reliability Project**

Bloomington - Indiana



Professional Certification. I hereby certify that these documents were prepared or approved by me, and that I am a duly licensed professional engineer under the laws of the State of Indiana, License No. PE19700034, Expiration Date: 7/31/2024



**ORANGE BARREL ENGINEERS**

www.orangebarrelengineers.com

ORANGE BARREL ENGINEERS, P.C.  
1469 North Magnolia Ave., Suite B,  
Ocala FL 34475  
317-758-7587

PREPARED FOR:  
**TNT Traffic Control**

PROJECT NAME:

**Road Closures For Pole Replacement Various Locations**

PROJECT ADDRESS:

**Madison Street and Morton Street  
Bloomington, IN  
Monroe County**

THESE DRAWINGS ARE THE PROPERTY OF TNT Traffic Control. THEY ARE INTENDED EXCLUSIVELY FOR USE ON THIS PROJECT ONLY. ANY RE-USE OF THESE PLANS WITHOUT THE EXPRESS WRITTEN CONSENT OF TNT Traffic Control IS PROHIBITED

ISSUED FOR: **Temporary Traffic Control** DATE: **1/5/2023**

Des. by: JPM  
Drawn by: JPM

REVISION			
NO	DESCRIPTION	BY	DATE

SHEET TITLE:  
**Temporary Traffic Control**

SHEET NUMBER:  
**1 OF 27**

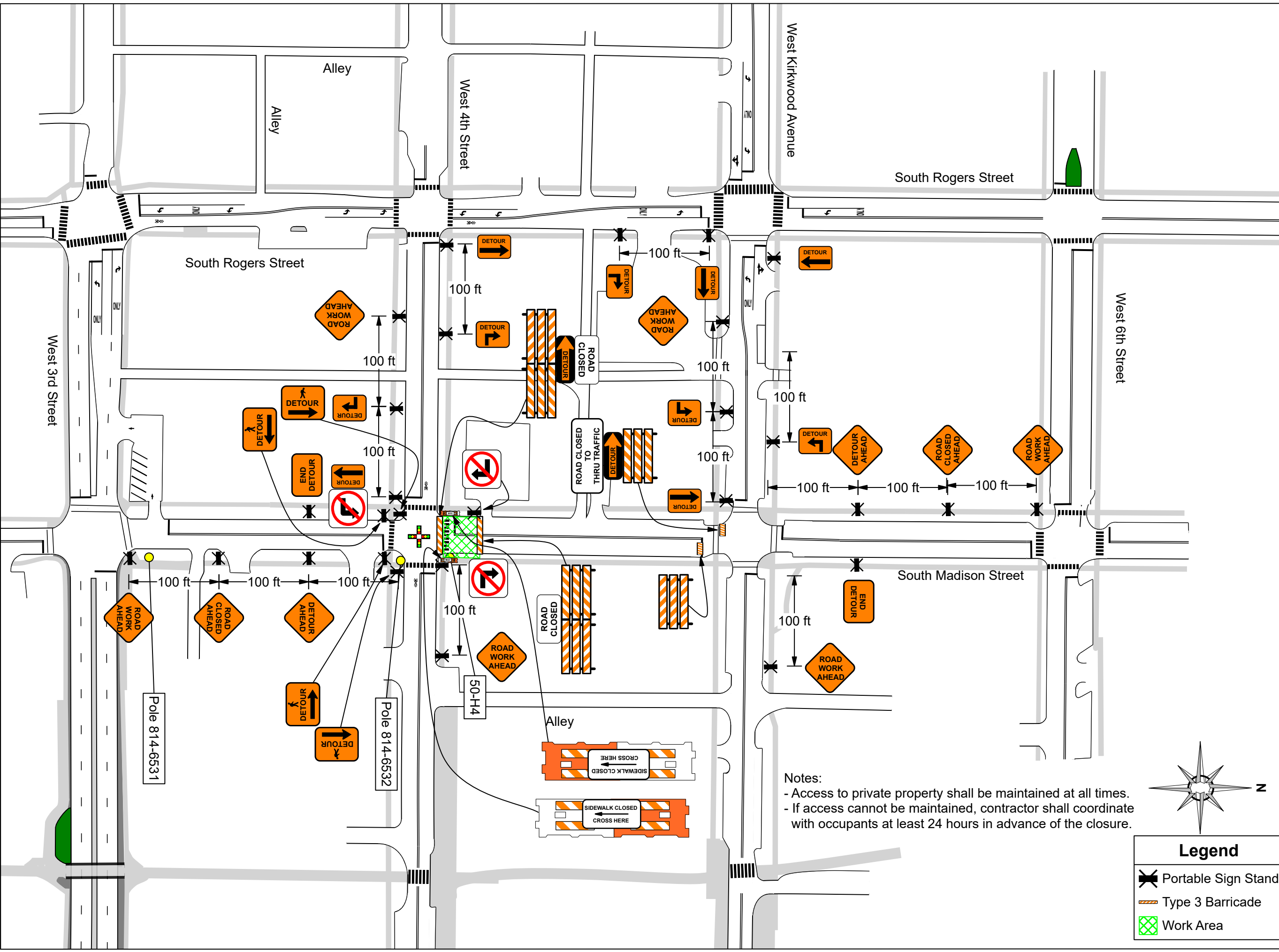

Notes:  
- Access to private property shall be maintained at all times.  
- If access cannot be maintained, contractor shall coordinate with occupants at least 24 hours in advance of the closure.

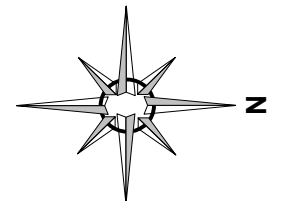

Legend	
	Portable Sign Stand
	Type 3 Barricade
	Work Area



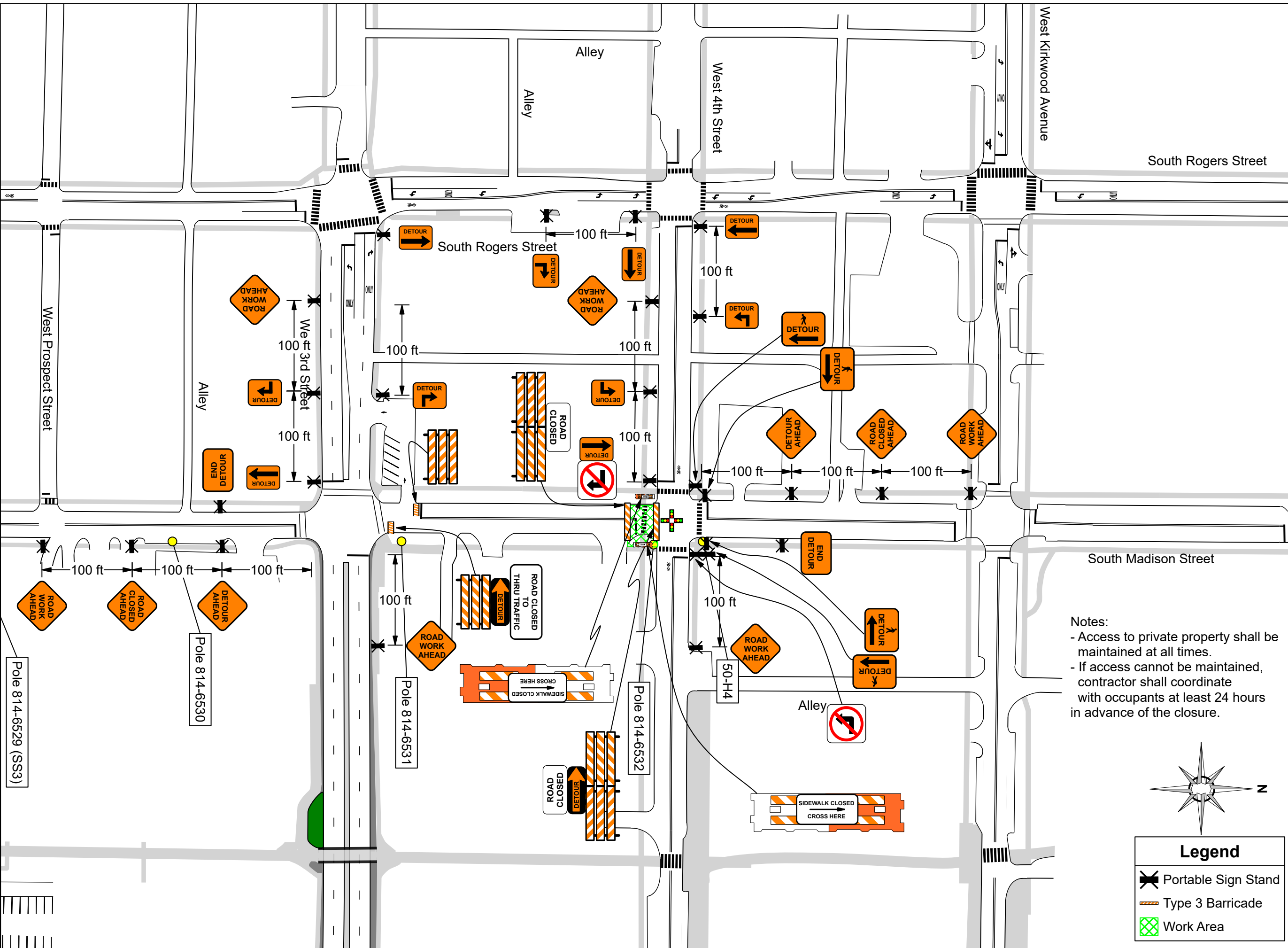

Professional Certification. I hereby certify that these documents were prepared or approved by me, and that I am a duly licensed professional engineer under the laws of the State of Indiana, License No. PE19700034, Expiration Date: 7/31/2024



**ORANGE BARREL ENGINEERS**

www.orangebarrelengineers.com

ORANGE BARREL ENGINEERS, P.C.  
1469 North Magnolia Ave., Suite B,  
Ocala FL 34475  
317-758-7587

PREPARED FOR:  
**TNT Traffic Control**

PROJECT NAME:

**Road Closures For Pole Replacement Various Locations**

PROJECT ADDRESS:

**Madison Street and Morton Street  
Bloomington, IN  
Monroe County**

THESE DRAWINGS ARE THE PROPERTY OF TNT Traffic Control. THEY ARE INTENDED EXCLUSIVELY FOR USE ON THIS PROJECT ONLY. ANY RE-USE OF THESE PLANS WITHOUT THE EXPRESS WRITTEN CONSENT OF TNT Traffic Control IS PROHIBITED

ISSUED FOR: **Temporary Traffic Control** DATE: **1/5/2023**

Des. by: JPM  
Drawn by: JPM

REVISION			
NO	DESCRIPTION	BY	DATE

SHEET TITLE:  
**Temporary Traffic Control**

SHEET NUMBER:  
**2 OF 27**

- Notes:
- Access to private property shall be maintained at all times.
  - If access cannot be maintained, contractor shall coordinate with occupants at least 24 hours in advance of the closure.

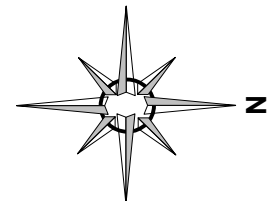

**Legend**

- Portable Sign Stand
- Type 3 Barricade
- Work Area



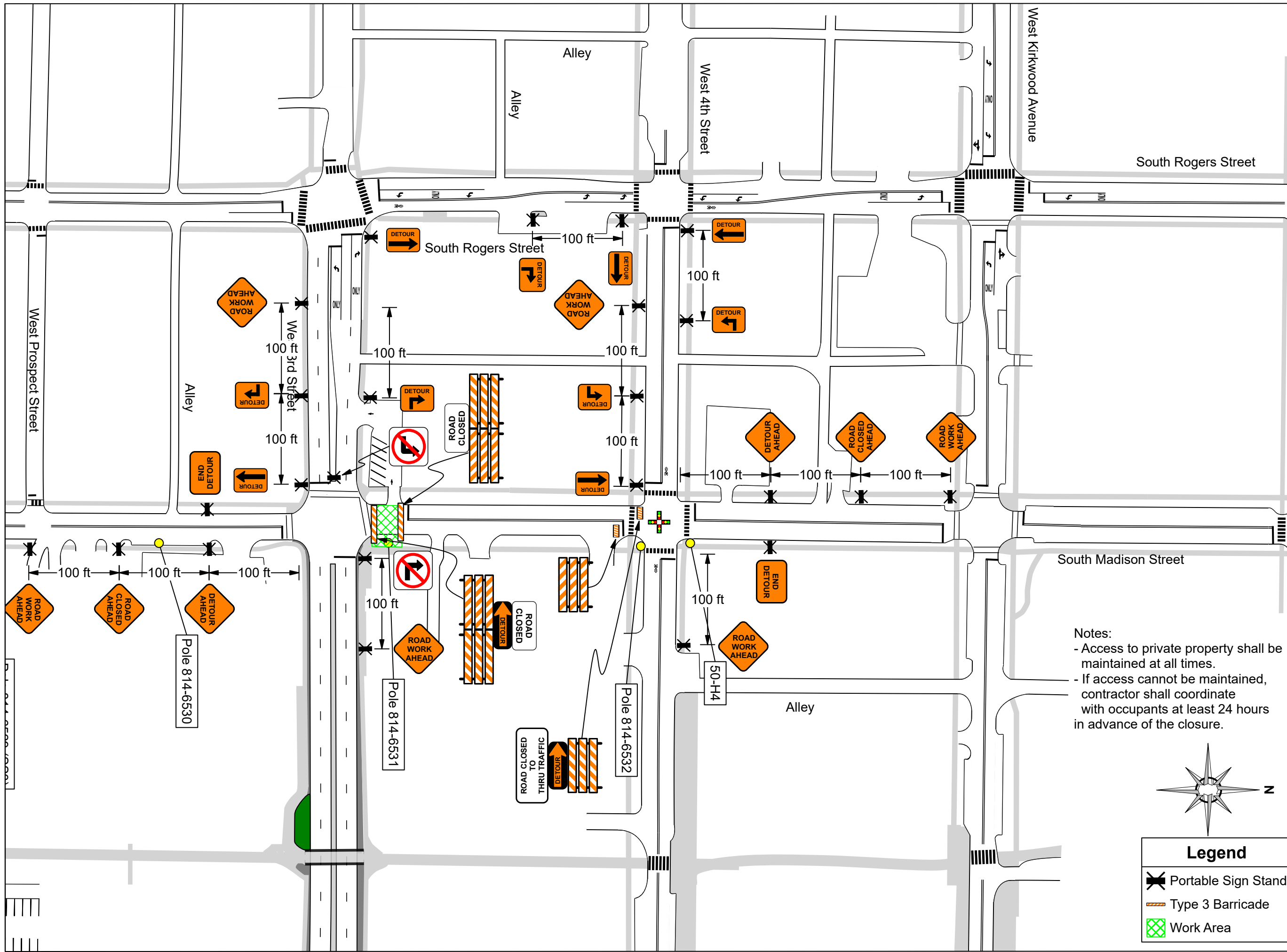

Professional Certification. I hereby certify that these documents were prepared or approved by me, and that I am a duly licensed professional engineer under the laws of the State of Indiana, License No. PE19700034, Expiration Date: 7/31/2024



**ORANGE BARREL ENGINEERS**

www.orangebarrelengineers.com

ORANGE BARREL ENGINEERS, P.C.  
1469 North Magnolia Ave., Suite B,  
Ocala FL 34475  
317-758-7587

PREPARED FOR:  
**TNT Traffic Control**

PROJECT NAME:

**Road Closures For Pole Replacement Various Locations**

PROJECT ADDRESS:

**Madison Street and Morton Street  
Bloomington, IN  
Monroe County**

THESE DRAWINGS ARE THE PROPERTY OF TNT Traffic Control. THEY ARE INTENDED EXCLUSIVELY FOR USE ON THIS PROJECT ONLY. ANY RE-USE OF THESE PLANS WITHOUT THE EXPRESS WRITTEN CONSENT OF TNT Traffic Control IS PROHIBITED

ISSUED FOR: Temporary Traffic Control DATE: 1/5/2023

Des. by: JPM  
Drawn by: JPM

REVISION			
NO	DESCRIPTION	BY	DATE

SHEET TITLE:  
**Temporary Traffic Control**

SHEET NUMBER:  
**3 OF 27**

- Notes:
- Access to private property shall be maintained at all times.
  - If access cannot be maintained, contractor shall coordinate with occupants at least 24 hours in advance of the closure.

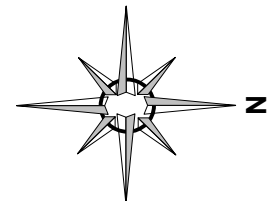

**Legend**

- Portable Sign Stand
- Type 3 Barricade
- Work Area

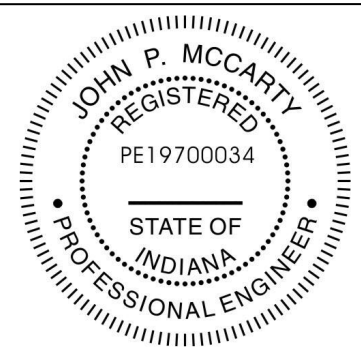

Professional Certification. I hereby certify that these documents were prepared or approved by me, and that I am a duly licensed professional engineer under the laws of the State of Indiana, License No. PE19700034, Expiration Date: 7/31/2024



**ORANGE BARREL ENGINEERS**

www.orangebarrelengineers.com

ORANGE BARREL ENGINEERS, P.C.  
1469 North Magnolia Ave., Suite B,  
Ocala FL 34475  
317-758-7587

PREPARED FOR:  
**TNT Traffic Control**

PROJECT NAME:

**Road Closures For Pole Replacement Various Locations**

PROJECT ADDRESS:

**Madison Street and Morton Street  
Bloomington, IN  
Monroe County**

THESE DRAWINGS ARE THE PROPERTY OF TNT Traffic Control. THEY ARE INTENDED EXCLUSIVELY FOR USE ON THIS PROJECT ONLY. ANY RE-USE OF THESE PLANS WITHOUT THE EXPRESS WRITTEN CONSENT OF TNT Traffic Control IS PROHIBITED

ISSUED FOR: Temporary Traffic Control DATE: 1/5/2023

Des. by: JPM  
Drawn by: JPM

**REVISION**

NO	DESCRIPTION	BY	DATE

SHEET TITLE:  
**Temporary Traffic Control**

SHEET NUMBER:  
**4 OF 27**

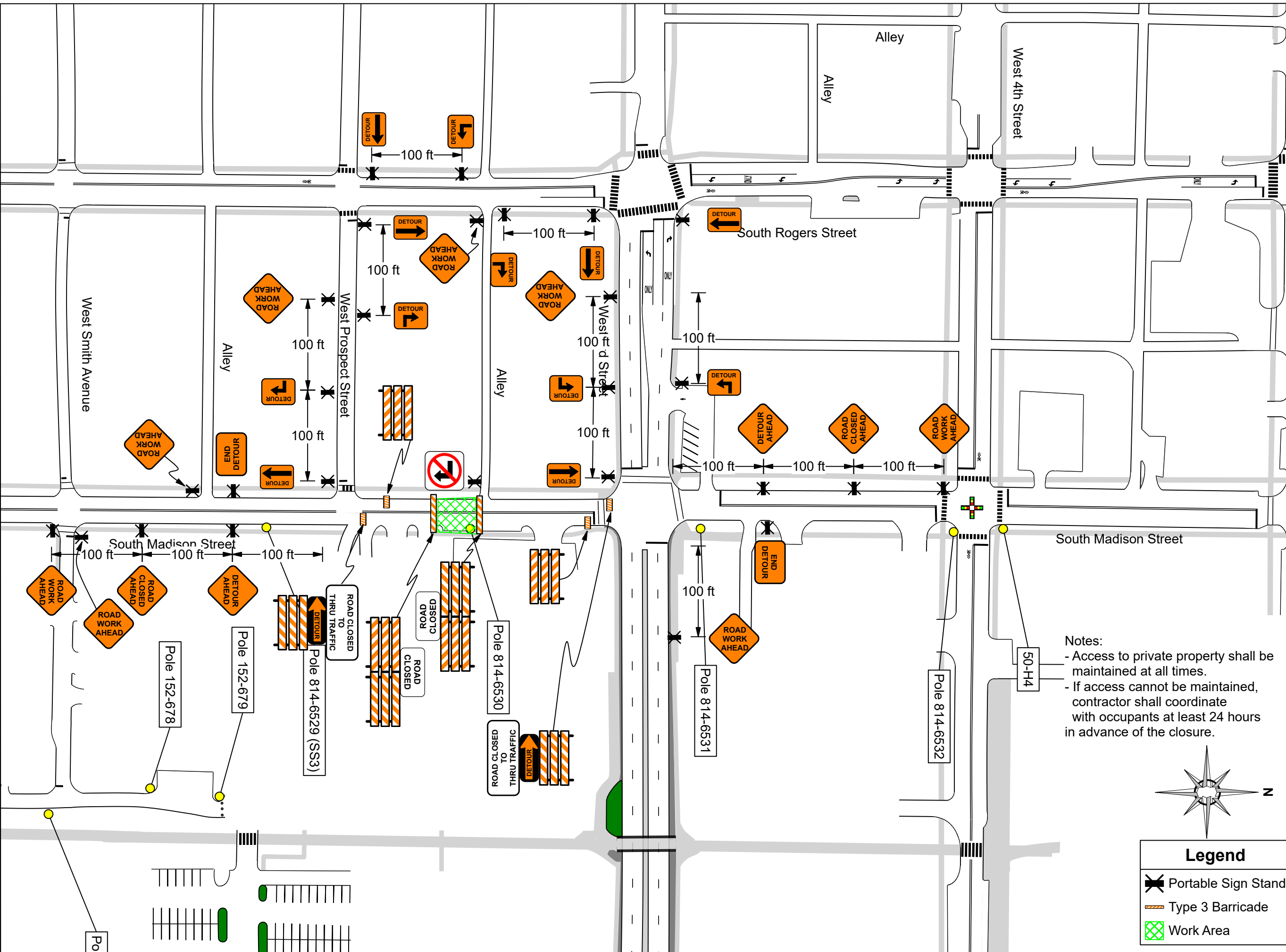

Notes:  
- Access to private property shall be maintained at all times.  
- If access cannot be maintained, contractor shall coordinate with occupants at least 24 hours in advance of the closure.

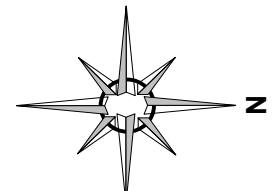

**Legend**

- Portable Sign Stand
- Type 3 Barricade
- Work Area

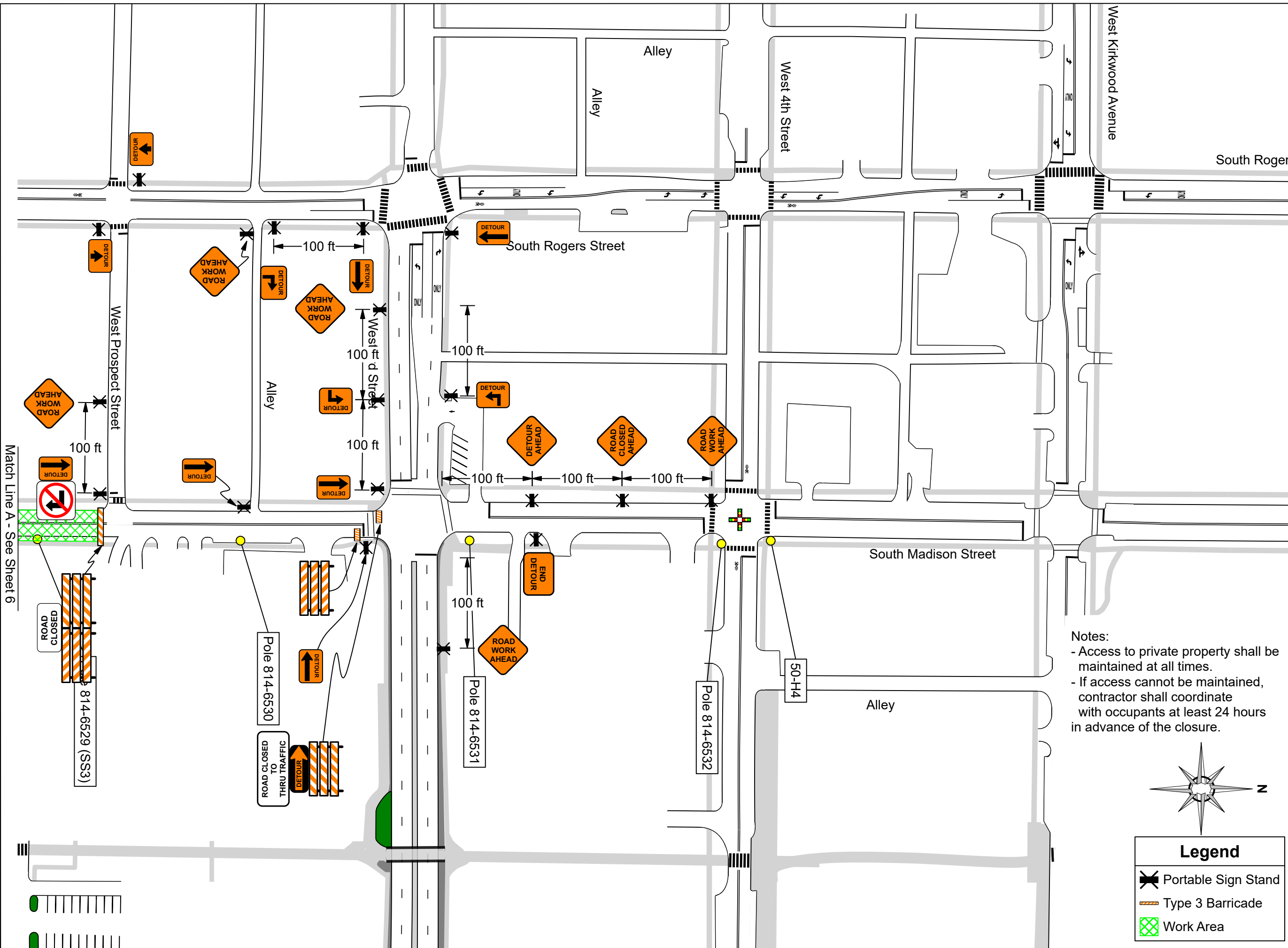

Professional Certification. I hereby certify that these documents were prepared or approved by me, and that I am a duly licensed professional engineer under the laws of the State of Indiana, License No. PE19700034, Expiration Date: 7/31/2024



**ORANGE BARREL ENGINEERS**

www.orangebarrelengineers.com

ORANGE BARREL ENGINEERS, P.C.  
1469 North Magnolia Ave., Suite B,  
Ocala FL 34475  
317-758-7587

PREPARED FOR:  
**TNT Traffic Control**

PROJECT NAME:

**Road Closures For Pole Replacement Various Locations**

PROJECT ADDRESS:

**Madison Street and Morton Street  
Bloomington, IN  
Monroe County**

THESE DRAWINGS ARE THE PROPERTY OF TNT Traffic Control. THEY ARE INTENDED EXCLUSIVELY FOR USE ON THIS PROJECT ONLY. ANY RE-USE OF THESE PLANS WITHOUT THE EXPRESS WRITTEN CONSENT OF TNT Traffic Control IS PROHIBITED

ISSUED FOR: Temporary Traffic Control DATE: 1/5/2023

Des. by: JPM  
Drawn by: JPM

REVISION			
NO	DESCRIPTION	BY	DATE

SHEET TITLE:  
**Temporary Traffic Control**

SHEET NUMBER:  
**5 OF 27**

- Notes:
- Access to private property shall be maintained at all times.
  - If access cannot be maintained, contractor shall coordinate with occupants at least 24 hours in advance of the closure.

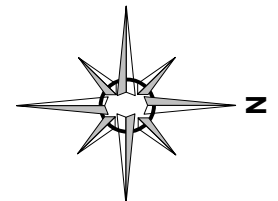

**Legend**

- Portable Sign Stand
- Type 3 Barricade
- Work Area

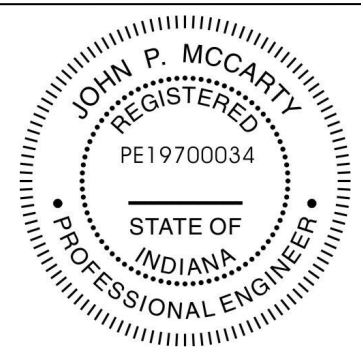

Professional Certification. I hereby certify that these documents were prepared or approved by me, and that I am a duly licensed professional engineer under the laws of the State of Indiana, License No. PE19700034, Expiration Date: 7/31/2024



**ORANGE BARREL ENGINEERS**

www.orangebarrelengineers.com

ORANGE BARREL ENGINEERS, P.C.  
1469 North Magnolia Ave., Suite B,  
Ocala FL 34475  
317-758-7587

PREPARED FOR:  
**TNT Traffic Control**

PROJECT NAME:

**Road Closures For Pole Replacement  
Various Locations**

PROJECT ADDRESS:

**Madison Street and Morton Street  
Bloomington, IN  
Monroe County**

THESE DRAWINGS ARE THE PROPERTY OF TNT Traffic Control. THEY ARE INTENDED EXCLUSIVELY FOR USE ON THIS PROJECT ONLY. ANY RE-USE OF THESE PLANS WITHOUT THE EXPRESS WRITTEN CONSENT OF TNT Traffic Control IS PROHIBITED

ISSUED FOR: **Temporary Traffic Control** DATE: **1/5/2023**

Des. by: JPM  
Drawn by: JPM

REVISION			
NO	DESCRIPTION	BY	DATE

SHEET TITLE:  
**Temporary Traffic Control**

SHEET NUMBER:  
**6 OF 27**

- Notes:
- Access to private property shall be maintained at all times.
  - If access cannot be maintained, contractor shall coordinate with occupants at least 24 hours in advance of the closure.

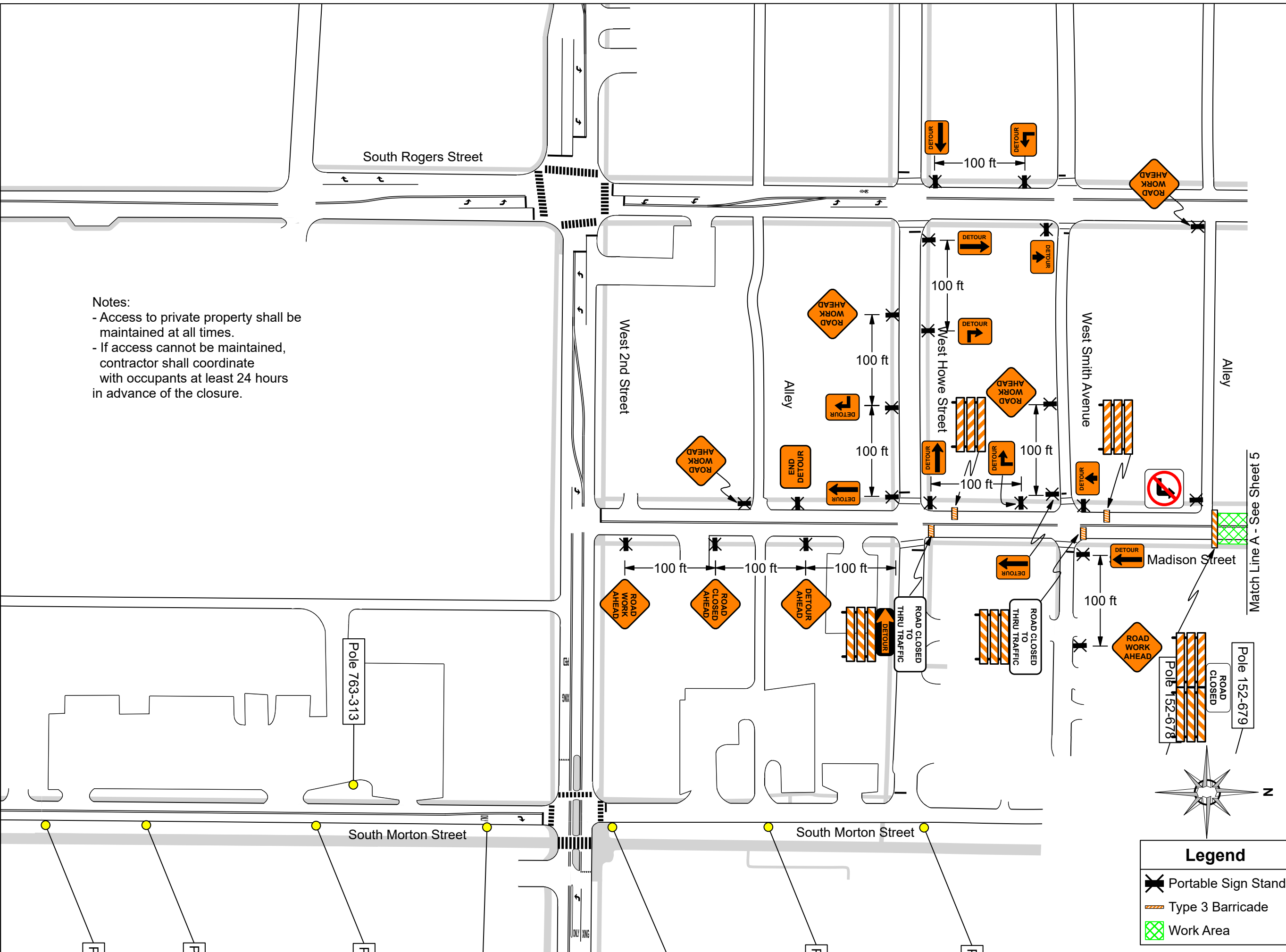

**Legend**

- ✖ Portable Sign Stand
- ▬ Type 3 Barricade
- ▨ Work Area





Professional Certification. I hereby certify that these documents were prepared or approved by me, and that I am a duly licensed professional engineer under the laws of the State of Indiana, License No. PE19700034, Expiration Date: 7/31/2024



**ORANGE BARREL ENGINEERS**

www.orangebarrelengineers.com

ORANGE BARREL ENGINEERS, P.C.  
1469 North Magnolia Ave., Suite B,  
Ocala FL 34475  
317-758-7587

PREPARED FOR:  
**TNT Traffic Control**

PROJECT NAME:

**Road Closures For Pole Replacement Various Locations**

PROJECT ADDRESS:

**Madison Street and Morton Street  
Bloomington, IN  
Monroe County**

THESE DRAWINGS ARE THE PROPERTY OF TNT Traffic Control. THEY ARE INTENDED EXCLUSIVELY FOR USE ON THIS PROJECT ONLY. ANY RE-USE OF THESE PLANS WITHOUT THE EXPRESS WRITTEN CONSENT OF TNT Traffic Control IS PROHIBITED

ISSUED FOR: **Temporary Traffic Control** DATE: **1/5/2023**

Des. by: JPM  
Drawn by: JPM

REVISION			
NO	DESCRIPTION	BY	DATE

SHEET TITLE:  
**Temporary Traffic Control**

SHEET NUMBER:  
**7 OF 27**

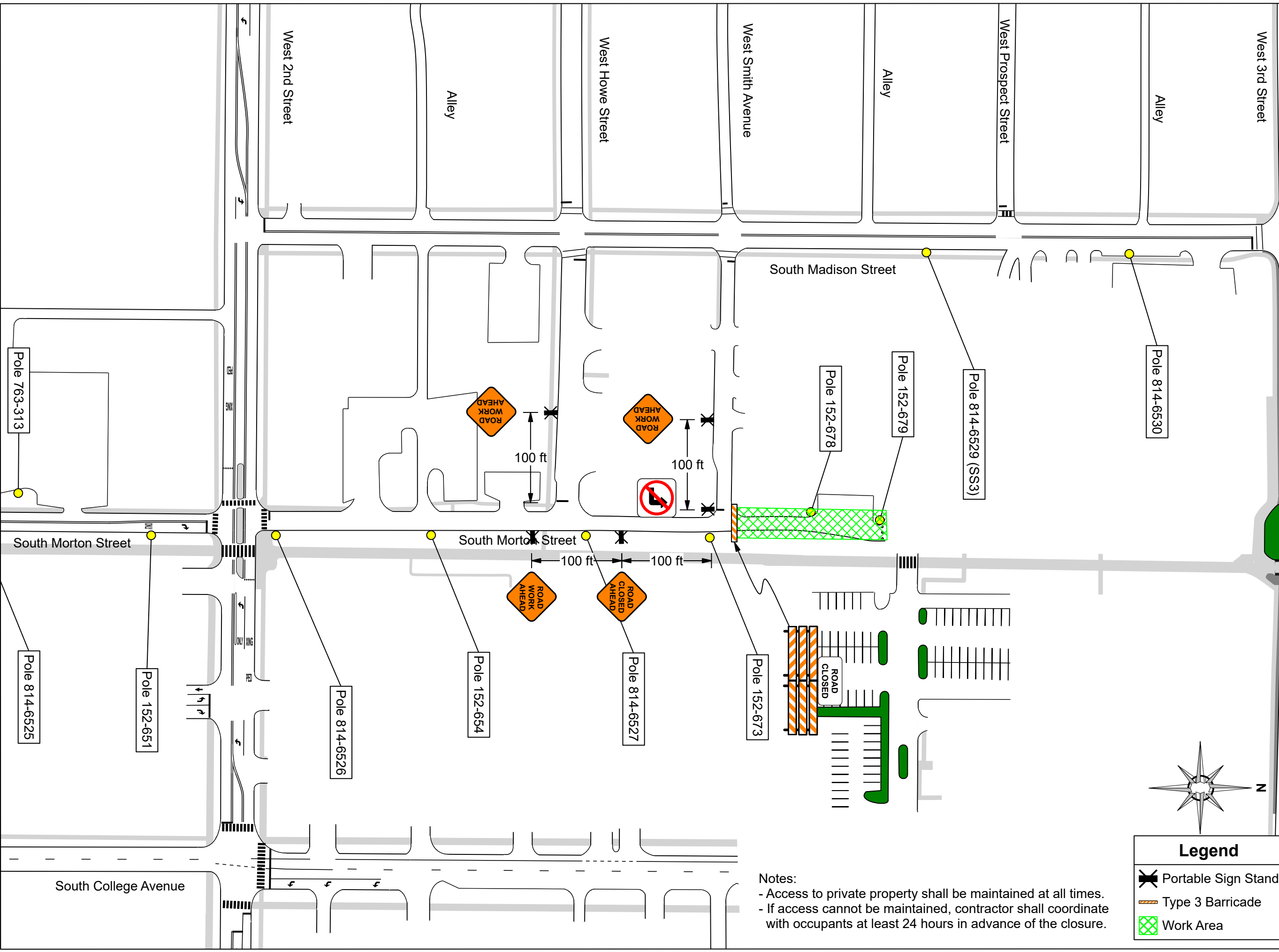

Notes:  
- Access to private property shall be maintained at all times.  
- If access cannot be maintained, contractor shall coordinate with occupants at least 24 hours in advance of the closure.

**Legend**

- Portable Sign Stand
- Type 3 Barricade
- Work Area

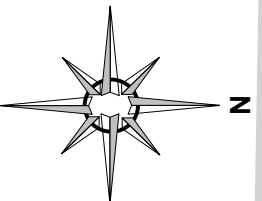



Professional Certification. I hereby certify that these documents were prepared or approved by me, and that I am a duly licensed professional engineer under the laws of the State of Indiana, License No. PE19700034, Expiration Date: 7/31/2024



**ORANGE BARREL ENGINEERS**

www.orangebarrelengineers.com

ORANGE BARREL ENGINEERS, P.C.  
1469 North Magnolia Ave., Suite B,  
Ocala FL 34475  
317-758-7587

PREPARED FOR:  
**TNT Traffic Control**

PROJECT NAME:

**Road Closures For Pole Replacement Various Locations**

PROJECT ADDRESS:

**Madison Street and Morton Street  
Bloomington, IN  
Monroe County**

THESE DRAWINGS ARE THE PROPERTY OF TNT Traffic Control. THEY ARE INTENDED EXCLUSIVELY FOR USE ON THIS PROJECT ONLY. ANY RE-USE OF THESE PLANS WITHOUT THE EXPRESS WRITTEN CONSENT OF TNT Traffic Control IS PROHIBITED

ISSUED FOR: **Temporary Traffic Control** DATE: **1/5/2023**

Des. by: JPM  
Drawn by: JPM

REVISION			
NO	DESCRIPTION	BY	DATE

SHEET TITLE:  
**Temporary Traffic Control**

SHEET NUMBER:  
**8 OF 27**

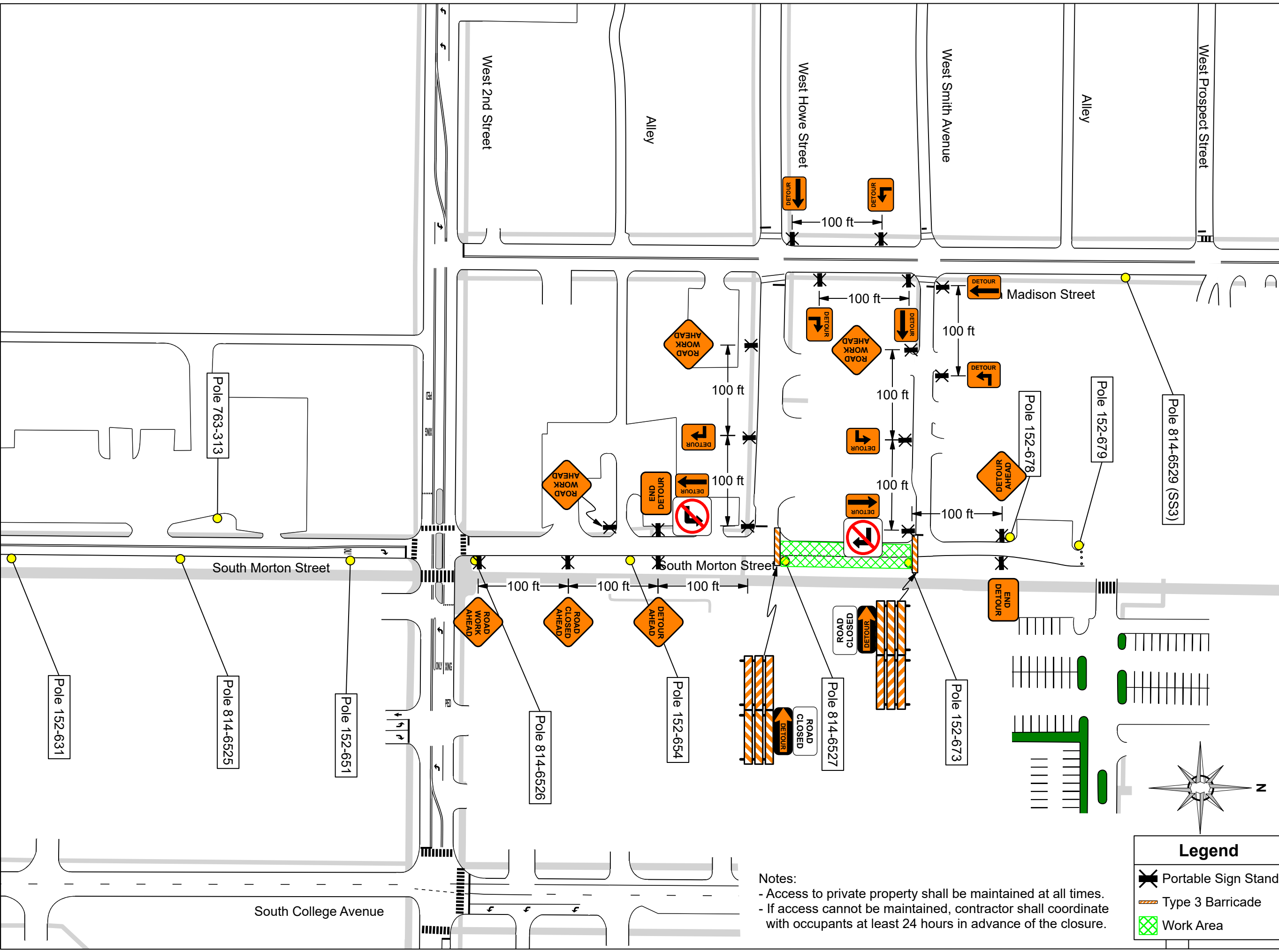

Notes:  
- Access to private property shall be maintained at all times.  
- If access cannot be maintained, contractor shall coordinate with occupants at least 24 hours in advance of the closure.

**Legend**

- Portable Sign Stand
- Type 3 Barricade
- Work Area

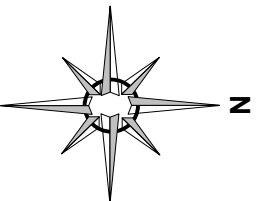





Professional Certification. I hereby certify that these documents were prepared or approved by me, and that I am a duly licensed professional engineer under the laws of the State of Indiana, License No. PE19700034, Expiration Date: 7/31/2024



**ORANGE BARREL ENGINEERS**

www.orangebarrelengineers.com

ORANGE BARREL ENGINEERS, P.C.  
1469 North Magnolia Ave., Suite B,  
Ocala FL 34475  
317-758-7587

PREPARED FOR:  
**TNT Traffic Control**

PROJECT NAME:

**Road Closures For Pole Replacement Various Locations**

PROJECT ADDRESS:

**Madison Street and Morton Street  
Bloomington, IN  
Monroe County**

THESE DRAWINGS ARE THE PROPERTY OF TNT Traffic Control. THEY ARE INTENDED EXCLUSIVELY FOR USE ON THIS PROJECT ONLY. ANY RE-USE OF THESE PLANS WITHOUT THE EXPRESS WRITTEN CONSENT OF TNT Traffic Control IS PROHIBITED

ISSUED FOR: **Temporary Traffic Control** DATE: **1/5/2023**

Des. by: JPM  
Drawn by: JPM

REVISION			
NO	DESCRIPTION	BY	DATE

SHEET TITLE:  
**Temporary Traffic Control**

SHEET NUMBER:  
**9 OF 27**

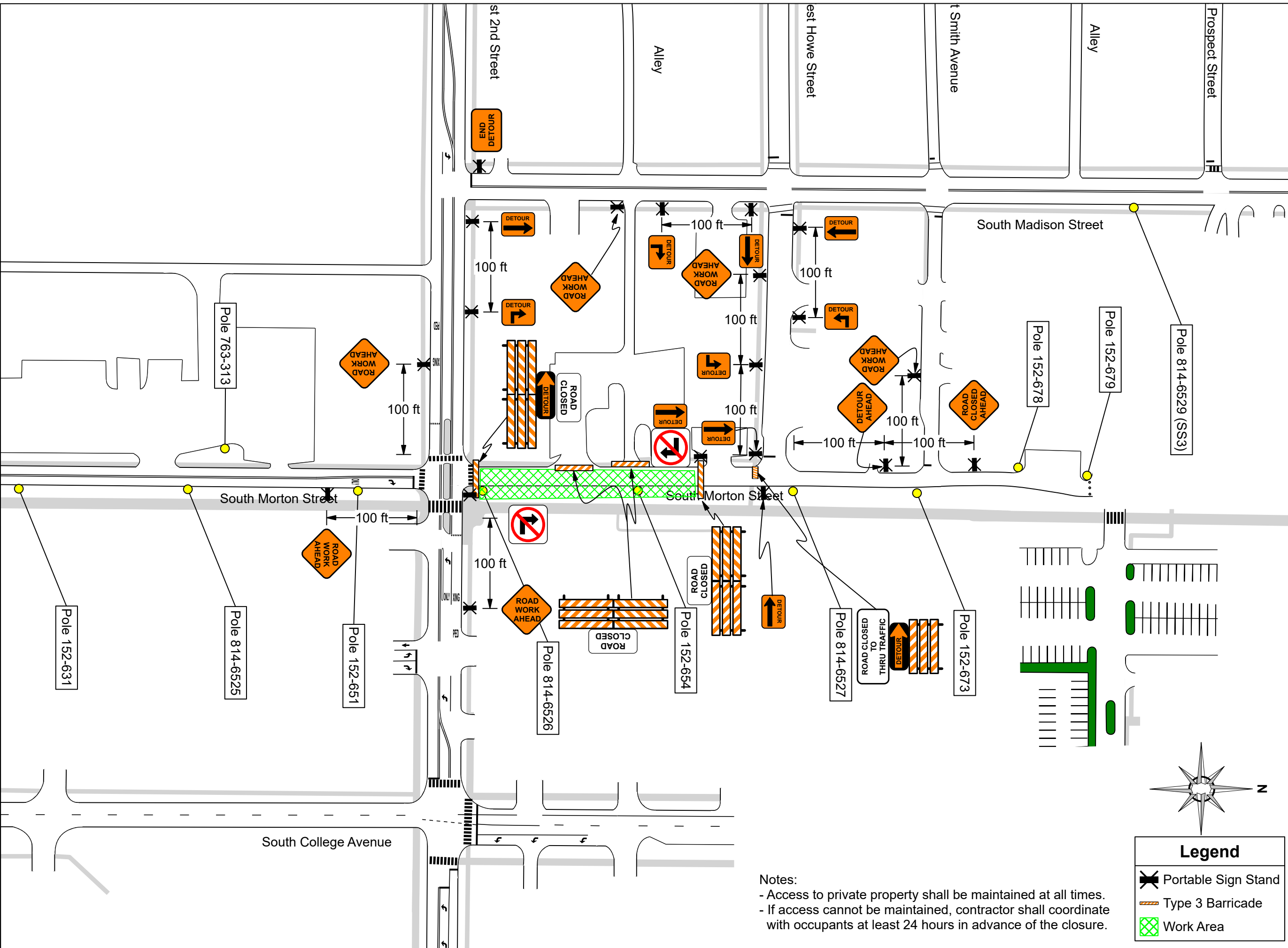

Notes:  
- Access to private property shall be maintained at all times.  
- If access cannot be maintained, contractor shall coordinate with occupants at least 24 hours in advance of the closure.

**Legend**

- Portable Sign Stand
- Type 3 Barricade
- Work Area

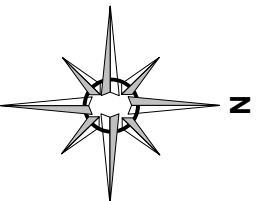

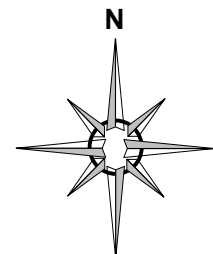
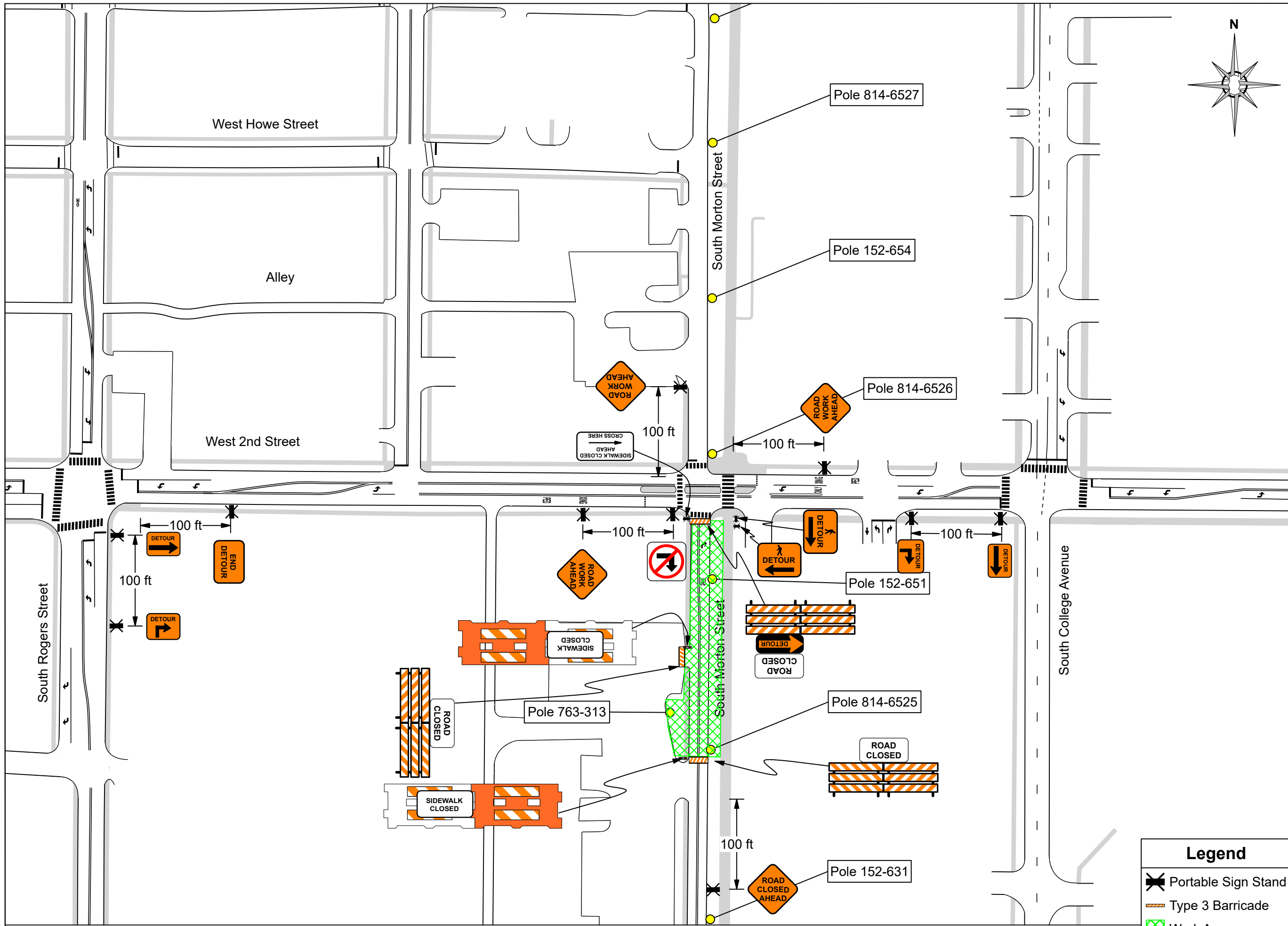

Professional Certification. I hereby certify that these documents were prepared or approved by me, and that I am a duly licensed professional engineer under the laws of the State of Indiana, License No. PE19700034, Expiration Date: 7/31/2024



ORANGE BARREL ENGINEERS  
www.orangebarrelengineers.com

ORANGE BARREL ENGINEERS, P.C.  
1469 North Magnolia Ave., Suite B,  
Ocala FL 34475  
317-758-7587

PREPARED FOR:  
**TNT Traffic Control**

PROJECT NAME:

**Road Closures For Pole Replacement Various Locations**

PROJECT ADDRESS:

**Madison Street and Morton Street  
Bloomington, IN  
Monroe County**

THESE DRAWINGS ARE THE PROPERTY OF TNT Traffic Control. THEY ARE INTENDED EXCLUSIVELY FOR USE ON THIS PROJECT ONLY. ANY RE-USE OF THESE PLANS WITHOUT THE EXPRESS WRITTEN CONSENT OF TNT Traffic Control IS PROHIBITED

ISSUED FOR: Temporary Traffic Control DATE: 1/5/2023

Des. by: JPM  
Drawn by: JPM

REVISION			
NO	DESCRIPTION	BY	DATE

SHEET TITLE:  
**Temporary Traffic Control**

SHEET NUMBER:  
**10 OF 27**

**Legend**

- Portable Sign Stand
- Type 3 Barricade
- Work Area

Match Line B - See Sheet 11

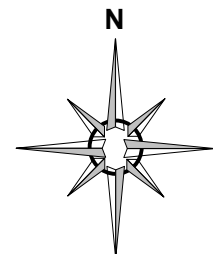

Professional Certification. I hereby certify that these documents were prepared or approved by me, and that I am a duly licensed professional engineer under the laws of the State of Indiana, License No. PE19700034, Expiration Date: 7/31/2024



**ORANGE BARREL ENGINEERS**

www.orangebarrelengineers.com

ORANGE BARREL ENGINEERS, P.C.  
1469 North Magnolia Ave., Suite B,  
Ocala FL 34475  
317-758-7587

PREPARED FOR:  
**TNT Traffic Control**

PROJECT NAME:

**Road Closures For Pole Replacement Various Locations**

PROJECT ADDRESS:

**Madison Street and Morton Street  
Bloomington, IN  
Monroe County**

THESE DRAWINGS ARE THE PROPERTY OF TNT Traffic Control. THEY ARE INTENDED EXCLUSIVELY FOR USE ON THIS PROJECT ONLY. ANY RE-USE OF THESE PLANS WITHOUT THE EXPRESS WRITTEN CONSENT OF TNT Traffic Control IS PROHIBITED

ISSUED FOR: DATE  
**Temporary Traffic Control** 1/5/2023

Des. by: JPM

Drawn by: JPM

REVISION			
NO	DESCRIPTION	BY	DATE

SHEET TITLE:  
**Temporary Traffic Control**

SHEET NUMBER:  
**11 OF 27**

Match Line B - See Sheet 10

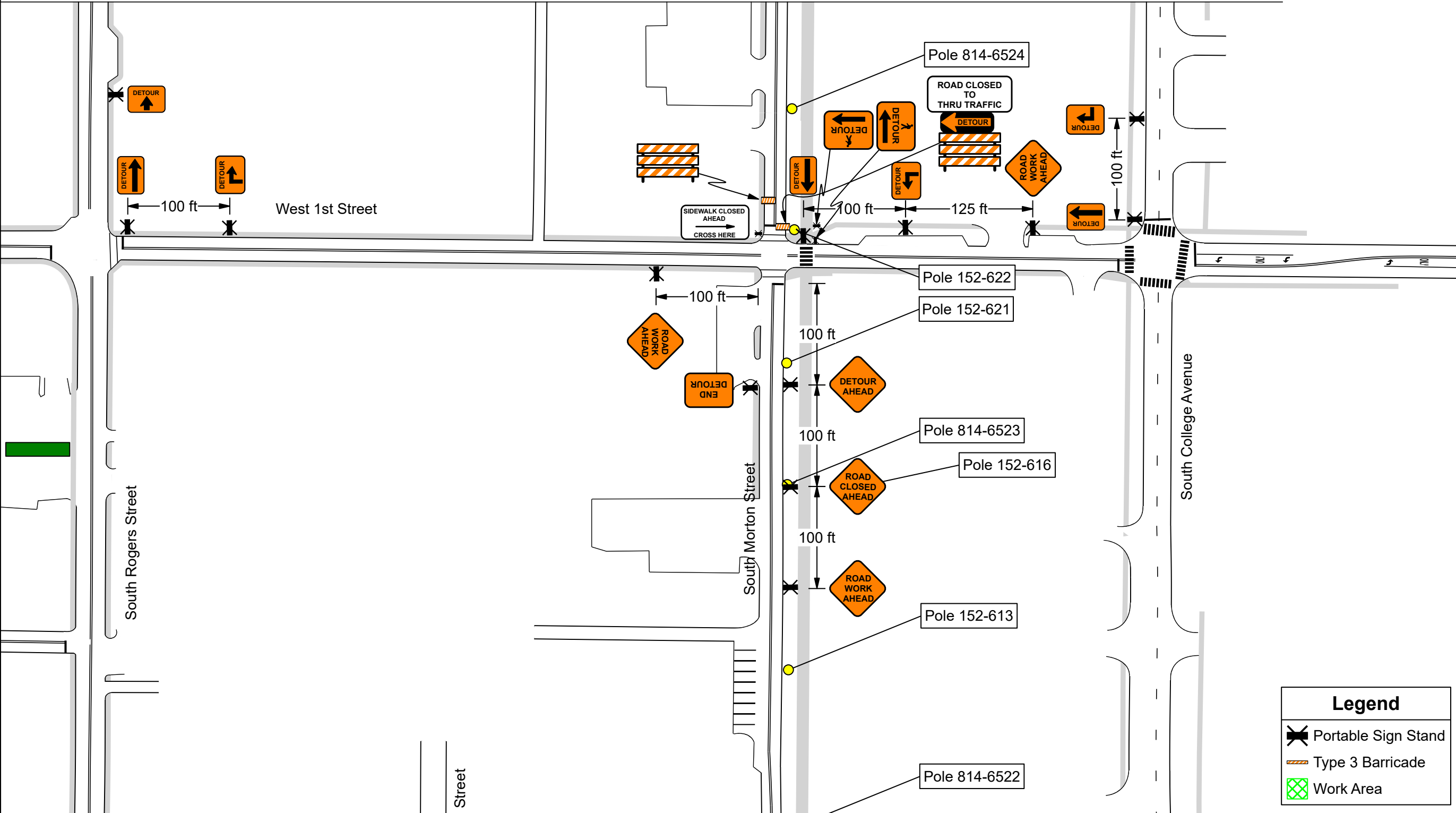

**Legend**

- Portable Sign Stand
- Type 3 Barricade
- Work Area

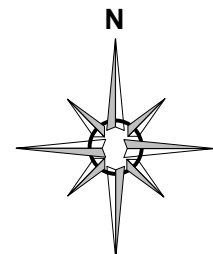
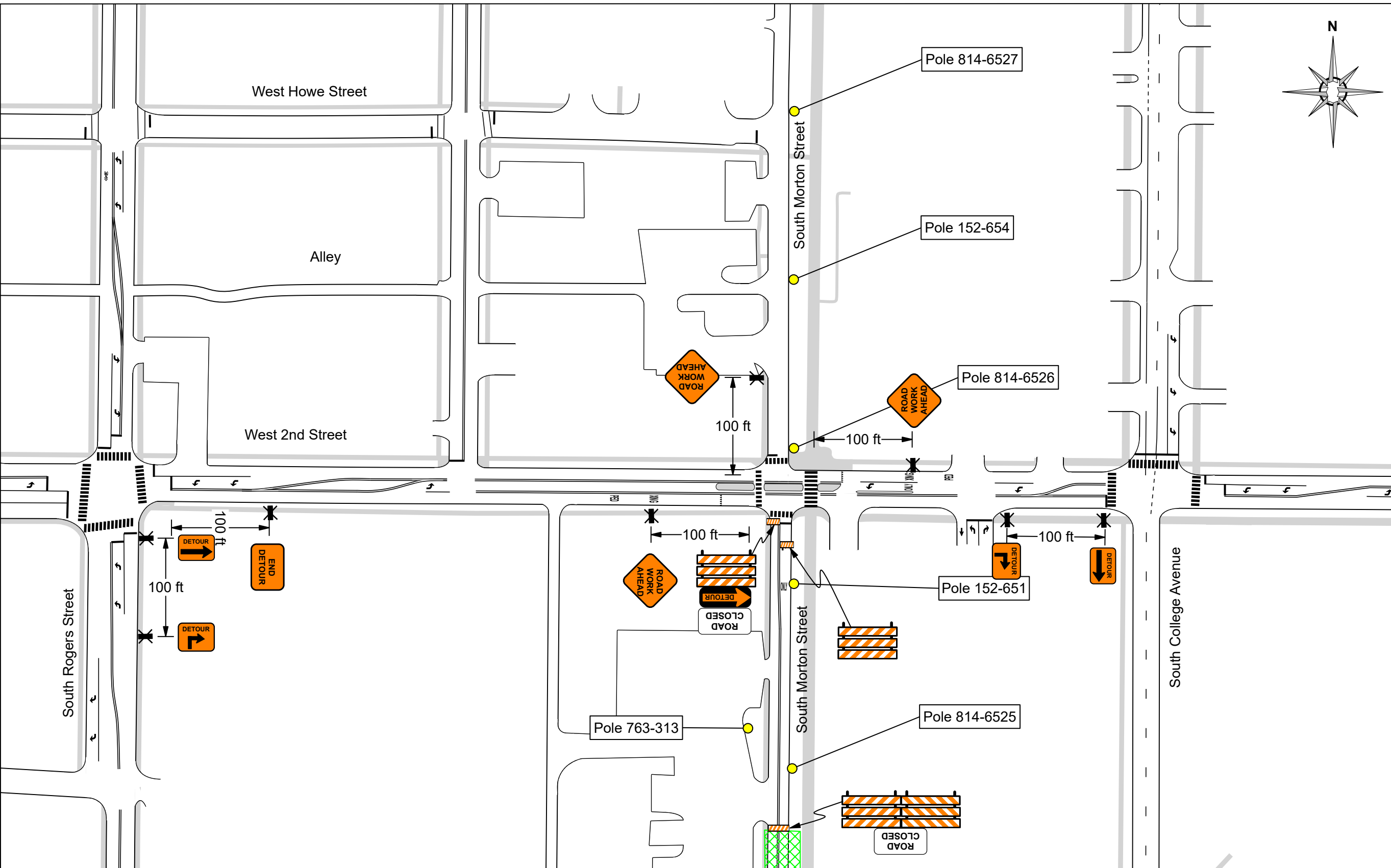

Professional Certification. I hereby certify that these documents were prepared or approved by me, and that I am a duly licensed professional engineer under the laws of the State of Indiana, License No. PE19700034, Expiration Date: 7/31/2024



**ORANGE BARREL ENGINEERS**  
www.orangebarrelengineers.com

ORANGE BARREL ENGINEERS, P.C.  
1469 North Magnolia Ave., Suite B,  
Ocala FL 34475  
317-758-7587

PREPARED FOR:  
**TNT Traffic Control**

PROJECT NAME:  
**Road Closures For Pole Replacement Various Locations**

PROJECT ADDRESS:  
**Madison Street and Morton Street  
Bloomington, IN  
Monroe County**

THESE DRAWINGS ARE THE PROPERTY OF TNT Traffic Control. THEY ARE INTENDED EXCLUSIVELY FOR USE ON THIS PROJECT ONLY. ANY RE-USE OF THESE PLANS WITHOUT THE EXPRESS WRITTEN CONSENT OF TNT Traffic Control IS PROHIBITED

ISSUED FOR: **Temporary Traffic Control** DATE: **1/5/2023**

Des. by: JPM  
Drawn by: JPM

REVISION			
NO	DESCRIPTION	BY	DATE

SHEET TITLE:  
**Temporary Traffic Control**

SHEET NUMBER:  
**12 OF 27**

Match Line C - See Sheet 13

**Legend**

- Portable Sign Stand
- Type 3 Barricade
- Work Area





Professional Certification. I hereby certify that these documents were prepared or approved by me, and that I am a duly licensed professional engineer under the laws of the State of Indiana, License No. PE19700034, Expiration Date: 7/31/2024



**ORANGE BARREL ENGINEERS**  
www.orangebarrelengineers.com

ORANGE BARREL ENGINEERS, P.C.  
1469 North Magnolia Ave., Suite B,  
Ocala FL 34475  
317-758-7587

PREPARED FOR:  
**TNT Traffic Control**

PROJECT NAME:

**Road Closures For Pole Replacement Various Locations**

PROJECT ADDRESS:

**Madison Street and Morton Street  
Bloomington, IN  
Monroe County**

THESE DRAWINGS ARE THE PROPERTY OF TNT Traffic Control. THEY ARE INTENDED EXCLUSIVELY FOR USE ON THIS PROJECT ONLY. ANY RE-USE OF THESE PLANS WITHOUT THE EXPRESS WRITTEN CONSENT OF TNT Traffic Control IS PROHIBITED

ISSUED FOR: **Temporary Traffic Control** DATE: **1/5/2023**

Des. by: JPM  
Drawn by: JPM

REVISION			
NO	DESCRIPTION	BY	DATE

SHEET TITLE:  
**Temporary Traffic Control**

SHEET NUMBER:  
**13 OF 27**

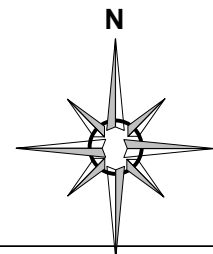

Match Line C - See Sheet 12

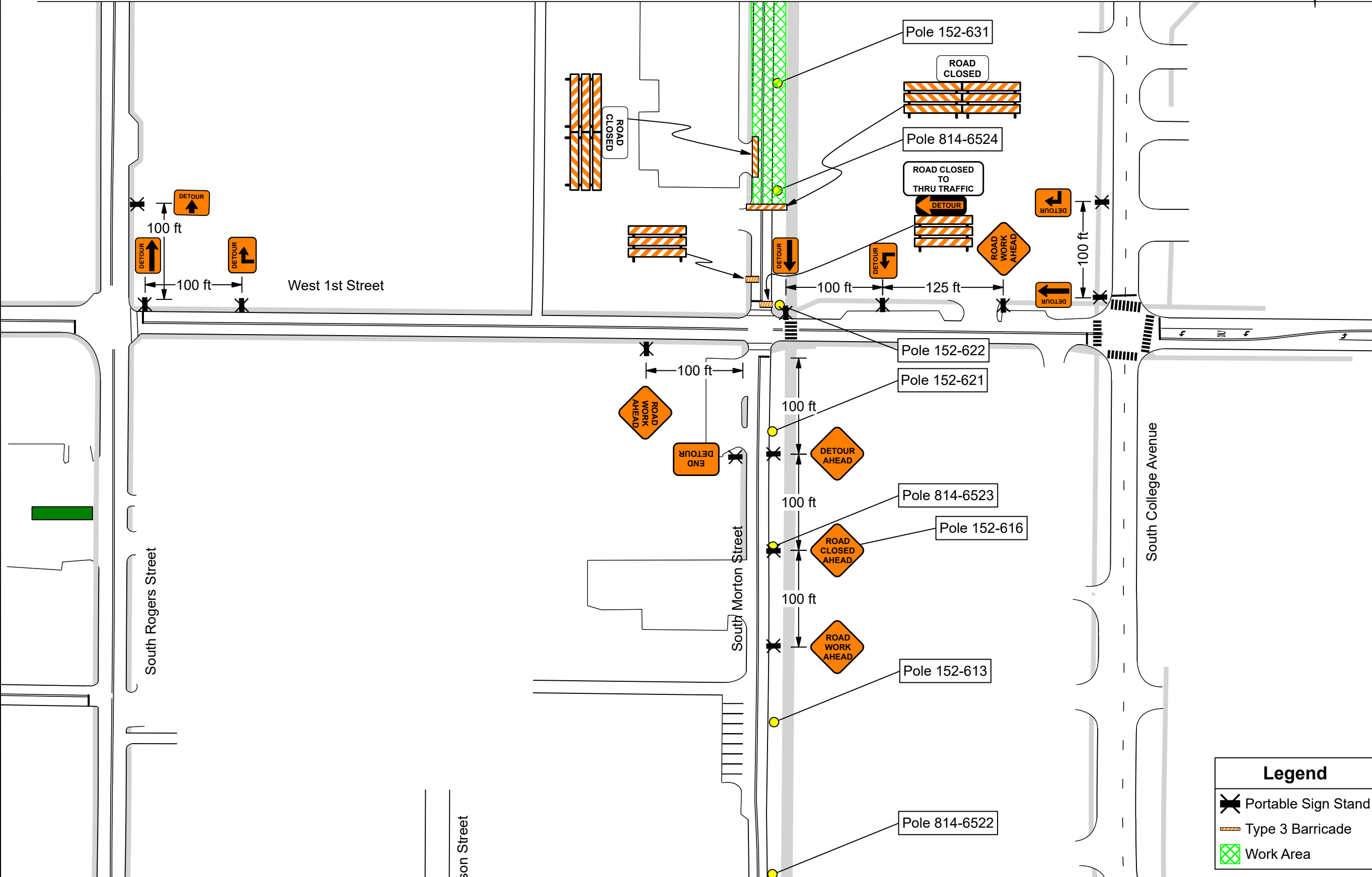

**Legend**

- Portable Sign Stand
- Type 3 Barricade
- Work Area

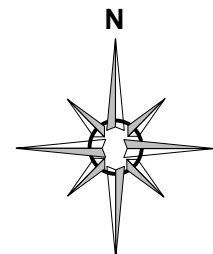
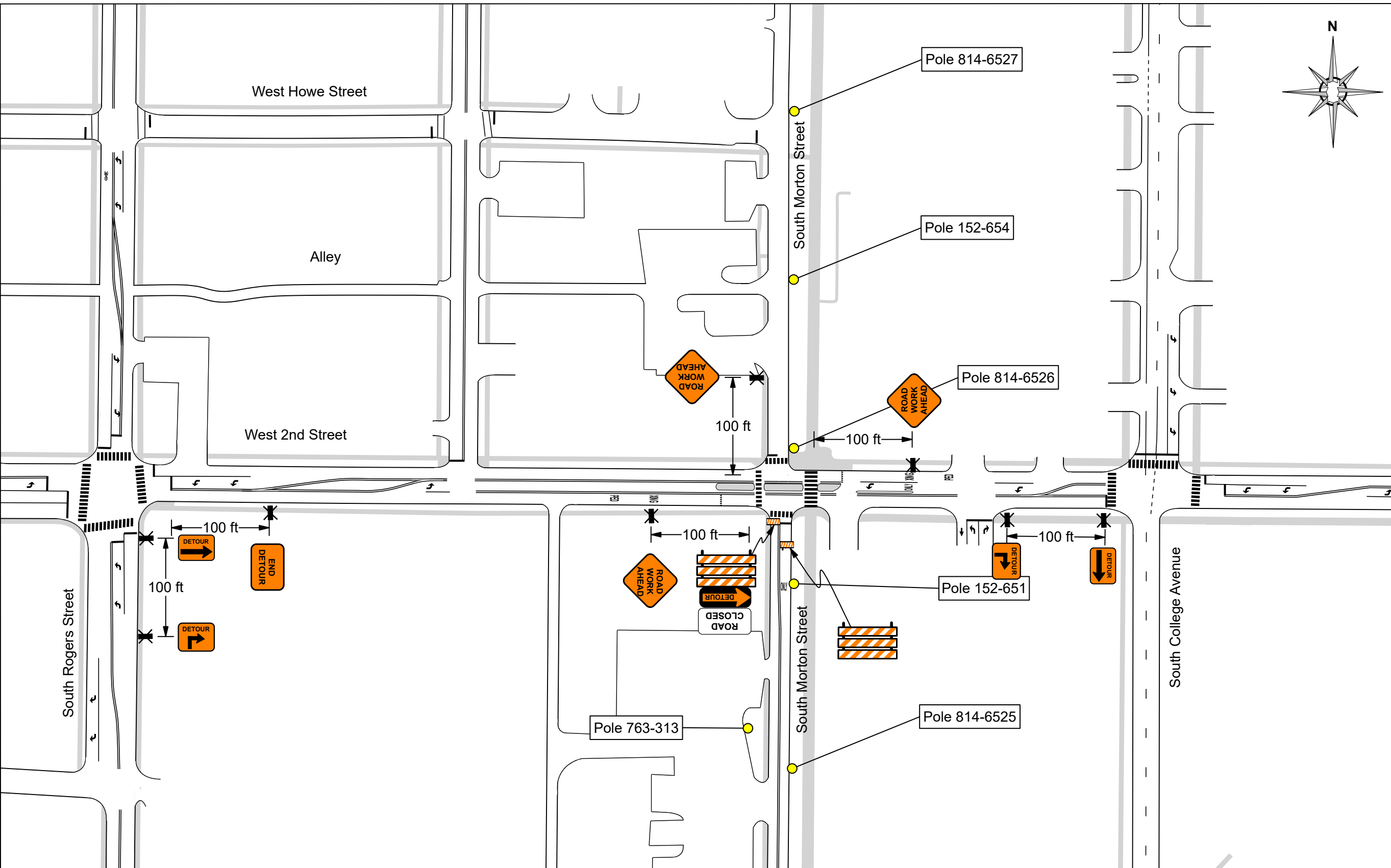

Professional Certification. I hereby certify that these documents were prepared or approved by me, and that I am a duly licensed professional engineer under the laws of the State of Indiana, License No. PE19700034, Expiration Date: 7/31/2024



**ORANGE BARREL ENGINEERS**  
www.orangebarrelengineers.com

ORANGE BARREL ENGINEERS, P.C.  
1469 North Magnolia Ave., Suite B,  
Ocala FL 34475  
317-758-7587

PREPARED FOR:  
**TNT Traffic Control**

PROJECT NAME:

**Road Closures For Pole Replacement Various Locations**

PROJECT ADDRESS:

**Madison Street and Morton Street  
Bloomington, IN  
Monroe County**

THESE DRAWINGS ARE THE PROPERTY OF TNT Traffic Control. THEY ARE INTENDED EXCLUSIVELY FOR USE ON THIS PROJECT ONLY. ANY RE-USE OF THESE PLANS WITHOUT THE EXPRESS WRITTEN CONSENT OF TNT Traffic Control IS PROHIBITED

ISSUED FOR: **Temporary Traffic Control** DATE: **1/5/2023**

Des. by: JPM  
Drawn by: JPM

REVISION			
NO	DESCRIPTION	BY	DATE

SHEET TITLE:  
**Temporary Traffic Control**

SHEET NUMBER:  
**14 OF 27**

Match Line D - See Sheet 15

**Legend**

- Portable Sign Stand
- Type 3 Barricade
- Work Area





Professional Certification. I hereby certify that these documents were prepared or approved by me, and that I am a duly licensed professional engineer under the laws of the State of Indiana, License No. PE19700034, Expiration Date: 7/31/2024

**OBE**  
**ORANGE BARREL ENGINEERS**  
 www.orangebarrelengineers.com  
 ORANGE BARREL ENGINEERS, P.C.  
 1469 North Magnolia Ave., Suite B,  
 Ocala FL 34475  
 317-758-7587

PREPARED FOR:  
**TNT Traffic Control**

PROJECT NAME:  
**Road Closures For Pole Replacement Various Locations**

PROJECT ADDRESS:  
**Madison Street and Morton Street  
 Bloomington, IN  
 Monroe County**

THESE DRAWINGS ARE THE PROPERTY OF TNT Traffic Control. THEY ARE INTENDED EXCLUSIVELY FOR USE ON THIS PROJECT ONLY. ANY RE-USE OF THESE PLANS WITHOUT THE EXPRESS WRITTEN CONSENT OF TNT Traffic Control IS PROHIBITED

ISSUED FOR: **Temporary Traffic Control** DATE: **1/5/2023**

Des. by: JPM  
 Drawn by: JPM

REVISION			
NO	DESCRIPTION	BY	DATE

SHEET TITLE:  
**Temporary Traffic Control**

SHEET NUMBER:  
**15 OF 27**

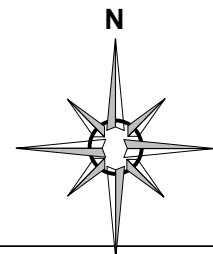

Match Line D - See Sheet 14

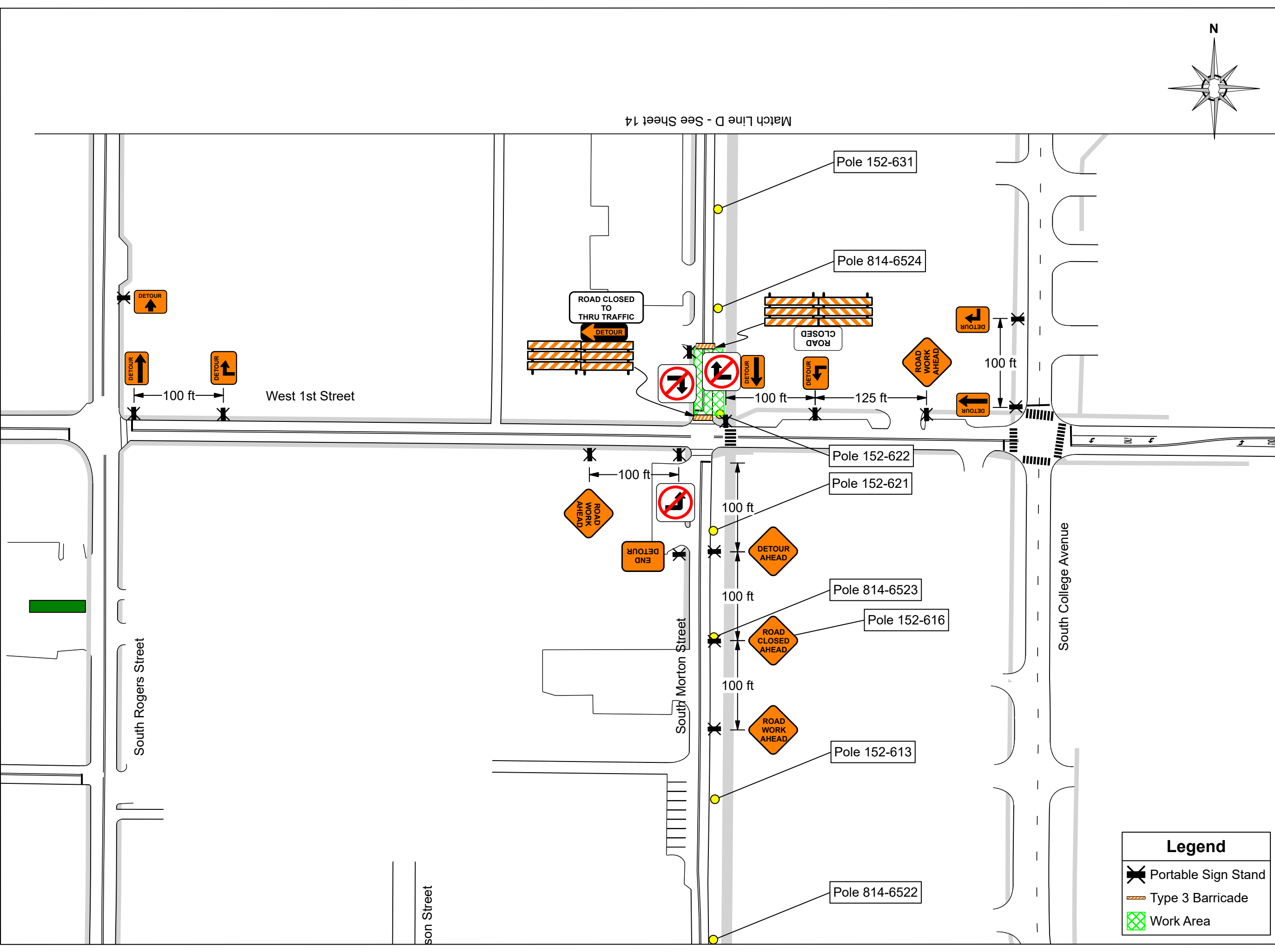

**Legend**

- Portable Sign Stand
- Type 3 Barricade
- Work Area

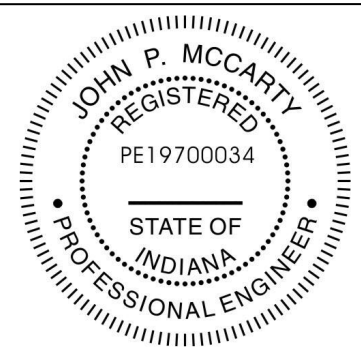

Professional Certification. I hereby certify that these documents were prepared or approved by me, and that I am a duly licensed professional engineer under the laws of the State of Indiana, License No. PE19700034, Expiration Date: 7/31/2024



**ORANGE BARREL ENGINEERS**

www.orangebarrelengineers.com

ORANGE BARREL ENGINEERS, P.C.  
1469 North Magnolia Ave., Suite B,  
Ocala FL 34475  
317-758-7587

PREPARED FOR:  
**TNT Traffic Control**

PROJECT NAME:

**Road Closures For Pole Replacement Various Locations**

PROJECT ADDRESS:

**Madison Street and Morton Street  
Bloomington, IN  
Monroe County**

THESE DRAWINGS ARE THE PROPERTY OF TNT Traffic Control. THEY ARE INTENDED EXCLUSIVELY FOR USE ON THIS PROJECT ONLY. ANY RE-USE OF THESE PLANS WITHOUT THE EXPRESS WRITTEN CONSENT OF TNT Traffic Control IS PROHIBITED

ISSUED FOR: Temporary Traffic Control DATE: 1/5/2023

Des. by: JPM  
Drawn by: JPM

REVISION			
NO	DESCRIPTION	BY	DATE

SHEET TITLE:  
**Temporary Traffic Control**

SHEET NUMBER:  
**16 OF 27**

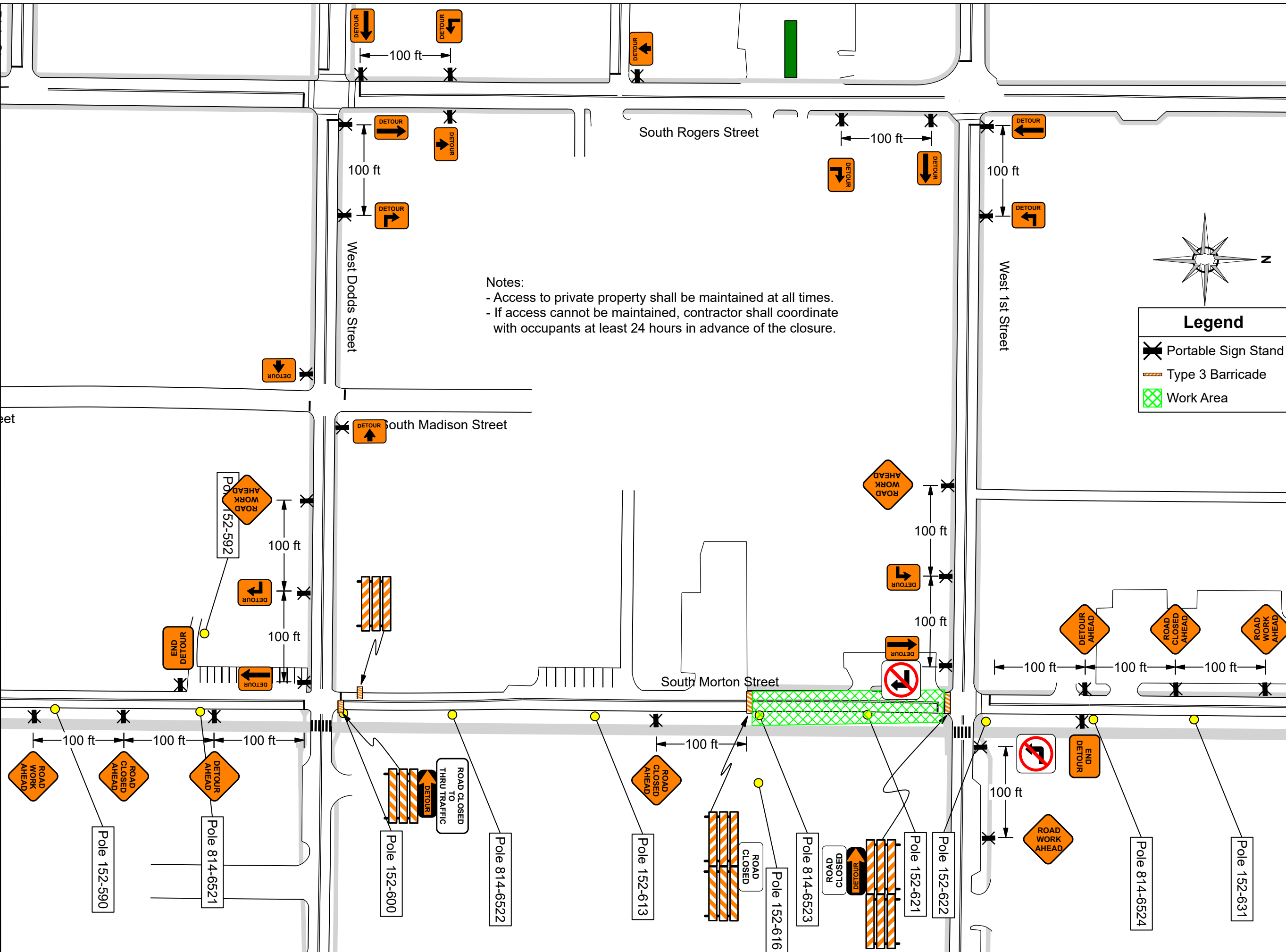

Notes:  
- Access to private property shall be maintained at all times.  
- If access cannot be maintained, contractor shall coordinate with occupants at least 24 hours in advance of the closure.

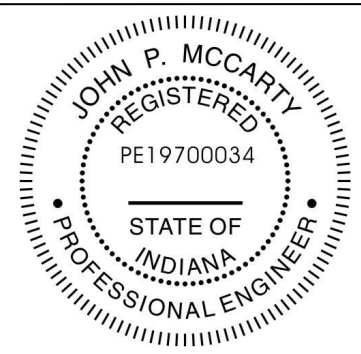

Professional Certification. I hereby certify that these documents were prepared or approved by me, and that I am a duly licensed professional engineer under the laws of the State of Indiana, License No. PE19700034, Expiration Date: 7/31/2024



**ORANGE BARREL ENGINEERS**

www.orangebarrelengineers.com

ORANGE BARREL ENGINEERS, P.C.  
1469 North Magnolia Ave., Suite B,  
Ocala FL 34475  
317-758-7587

PREPARED FOR:  
**TNT Traffic Control**

PROJECT NAME:

**Road Closures For Pole Replacement Various Locations**

PROJECT ADDRESS:

**Madison Street and Morton Street  
Bloomington, IN  
Monroe County**

THESE DRAWINGS ARE THE PROPERTY OF TNT Traffic Control. THEY ARE INTENDED EXCLUSIVELY FOR USE ON THIS PROJECT ONLY. ANY RE-USE OF THESE PLANS WITHOUT THE EXPRESS WRITTEN CONSENT OF TNT Traffic Control IS PROHIBITED

ISSUED FOR: Temporary Traffic Control DATE: 1/5/2023

Des. by: JPM  
Drawn by: JPM

REVISION			
NO	DESCRIPTION	BY	DATE

SHEET TITLE:  
**Temporary Traffic Control**

SHEET NUMBER:  
**17 OF 27**

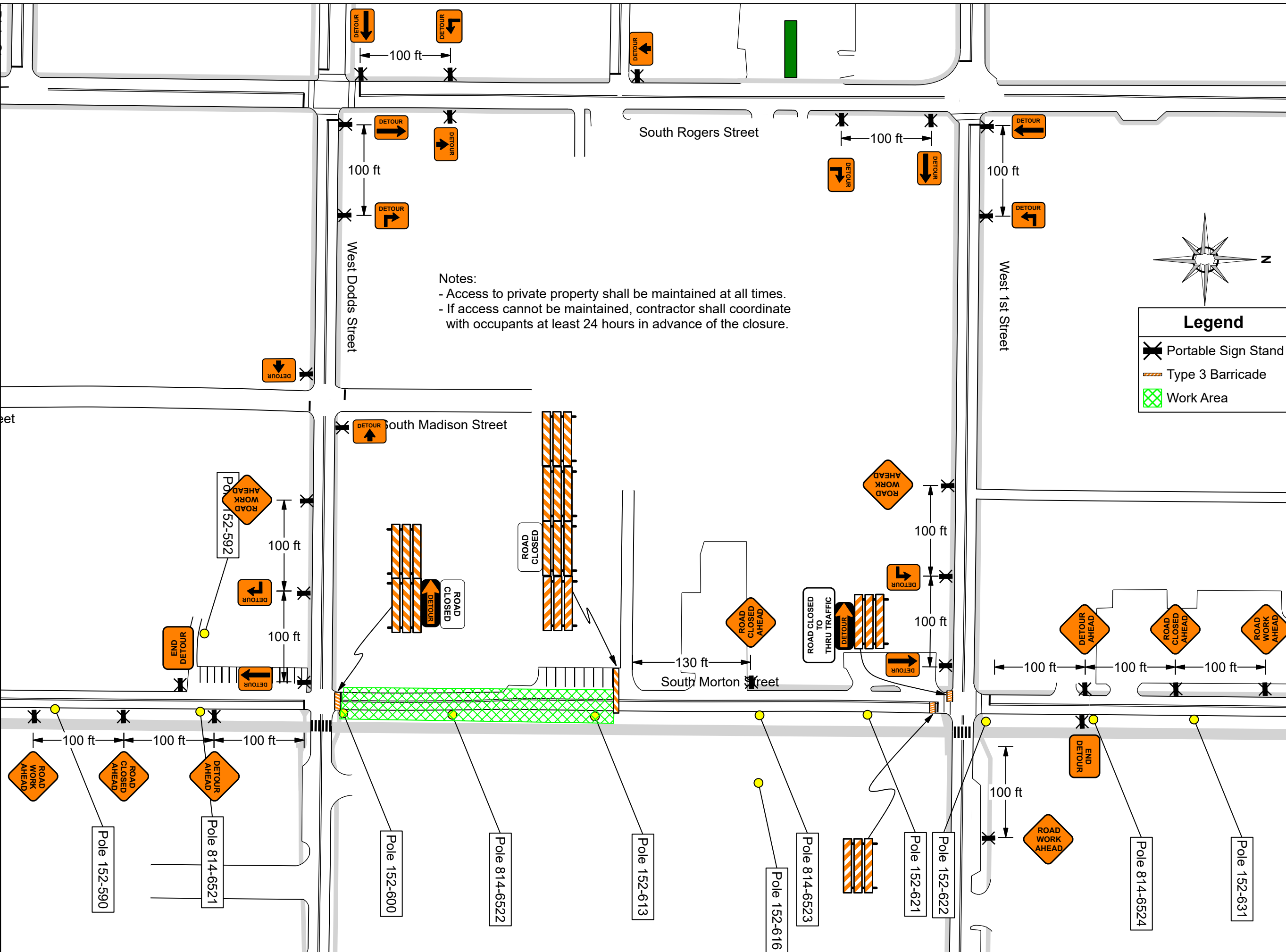

Notes:  
 - Access to private property shall be maintained at all times.  
 - If access cannot be maintained, contractor shall coordinate with occupants at least 24 hours in advance of the closure.

**Legend**

- ✂ Portable Sign Stand
- ▬ Type 3 Barricade
- ▨ Work Area

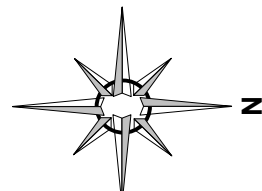







Professional Certification. I hereby certify that these documents were prepared or approved by me, and that I am a duly licensed professional engineer under the laws of the State of Indiana, License No. PE19700034, Expiration Date: 7/31/2024



**ORANGE BARREL ENGINEERS**  
www.orangebarrelengineers.com

ORANGE BARREL ENGINEERS, P.C.  
1469 North Magnolia Ave., Suite B,  
Ocala FL 34475  
317-758-7587

PREPARED FOR:  
**TNT Traffic Control**

PROJECT NAME:  
**Road Closures For Pole Replacement Various Locations**

PROJECT ADDRESS:  
**Madison Street and Morton Street  
Bloomington, IN  
Monroe County**

THESE DRAWINGS ARE THE PROPERTY OF TNT Traffic Control. THEY ARE INTENDED EXCLUSIVELY FOR USE ON THIS PROJECT ONLY. ANY RE-USE OF THESE PLANS WITHOUT THE EXPRESS WRITTEN CONSENT OF TNT Traffic Control IS PROHIBITED

ISSUED FOR: **Temporary Traffic Control** DATE: **1/5/2023**

Des. by: JPM  
Drawn by: JPM

REVISION			
NO	DESCRIPTION	BY	DATE

SHEET TITLE:  
**Temporary Traffic Control**

SHEET NUMBER:  
**19 OF 27**

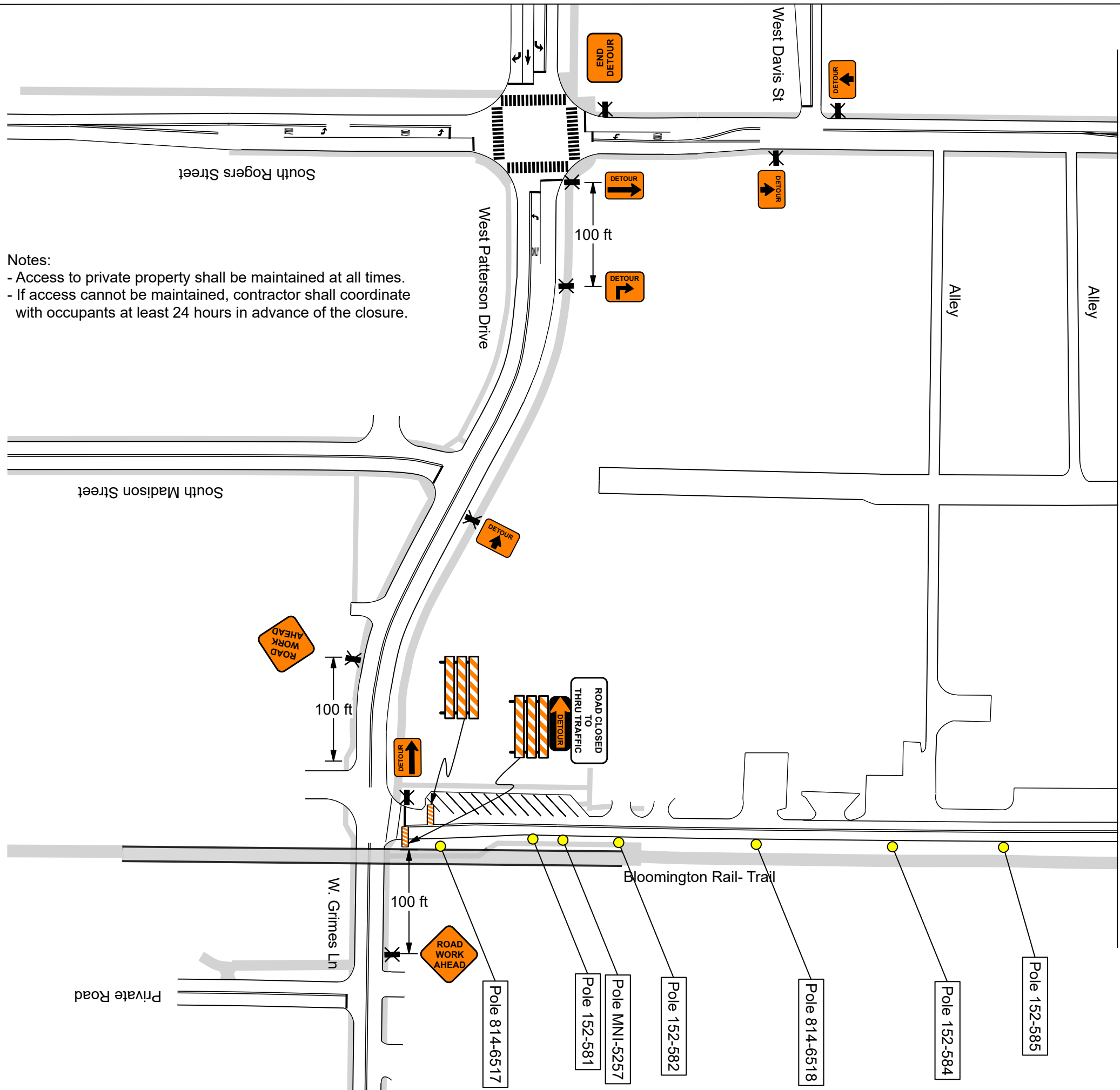

Notes:  
- Access to private property shall be maintained at all times.  
- If access cannot be maintained, contractor shall coordinate with occupants at least 24 hours in advance of the closure.

**Legend**

- Portable Sign Stand
- Type 3 Barricade
- Work Area

Match Line E - See Sheet 18

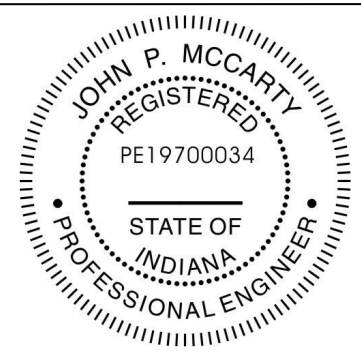

Professional Certification. I hereby certify that these documents were prepared or approved by me, and that I am a duly licensed professional engineer under the laws of the State of Indiana, License No. PE19700034, Expiration Date: 7/31/2024



**ORANGE BARREL ENGINEERS**

www.orangebarrelengineers.com

ORANGE BARREL ENGINEERS, P.C.  
1469 North Magnolia Ave., Suite B,  
Ocala FL 34475  
317-758-7587

PREPARED FOR:  
**TNT Traffic Control**

PROJECT NAME:

**Road Closures For Pole Replacement Various Locations**

PROJECT ADDRESS:

**Madison Street and Morton Street  
Bloomington, IN  
Monroe County**

THESE DRAWINGS ARE THE PROPERTY OF TNT Traffic Control. THEY ARE INTENDED EXCLUSIVELY FOR USE ON THIS PROJECT ONLY. ANY RE-USE OF THESE PLANS WITHOUT THE EXPRESS WRITTEN CONSENT OF TNT Traffic Control IS PROHIBITED

ISSUED FOR: **Temporary Traffic Control** DATE: **1/5/2023**

Des. by: JPM  
Drawn by: JPM

REVISION			
NO	DESCRIPTION	BY	DATE

SHEET TITLE:  
**Temporary Traffic Control**

SHEET NUMBER:  
**20 OF 27**

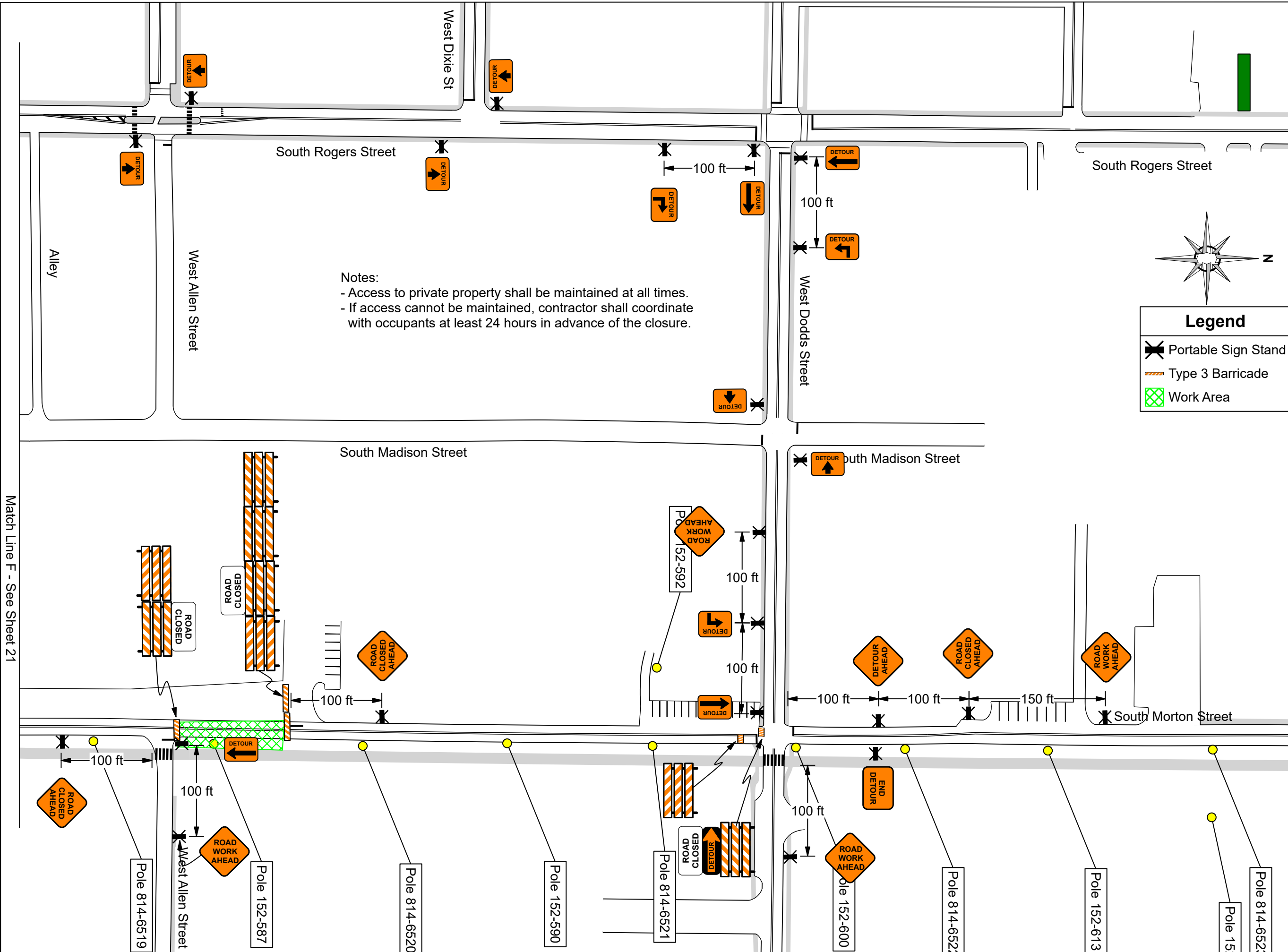

Notes:  
- Access to private property shall be maintained at all times.  
- If access cannot be maintained, contractor shall coordinate with occupants at least 24 hours in advance of the closure.

**Legend**



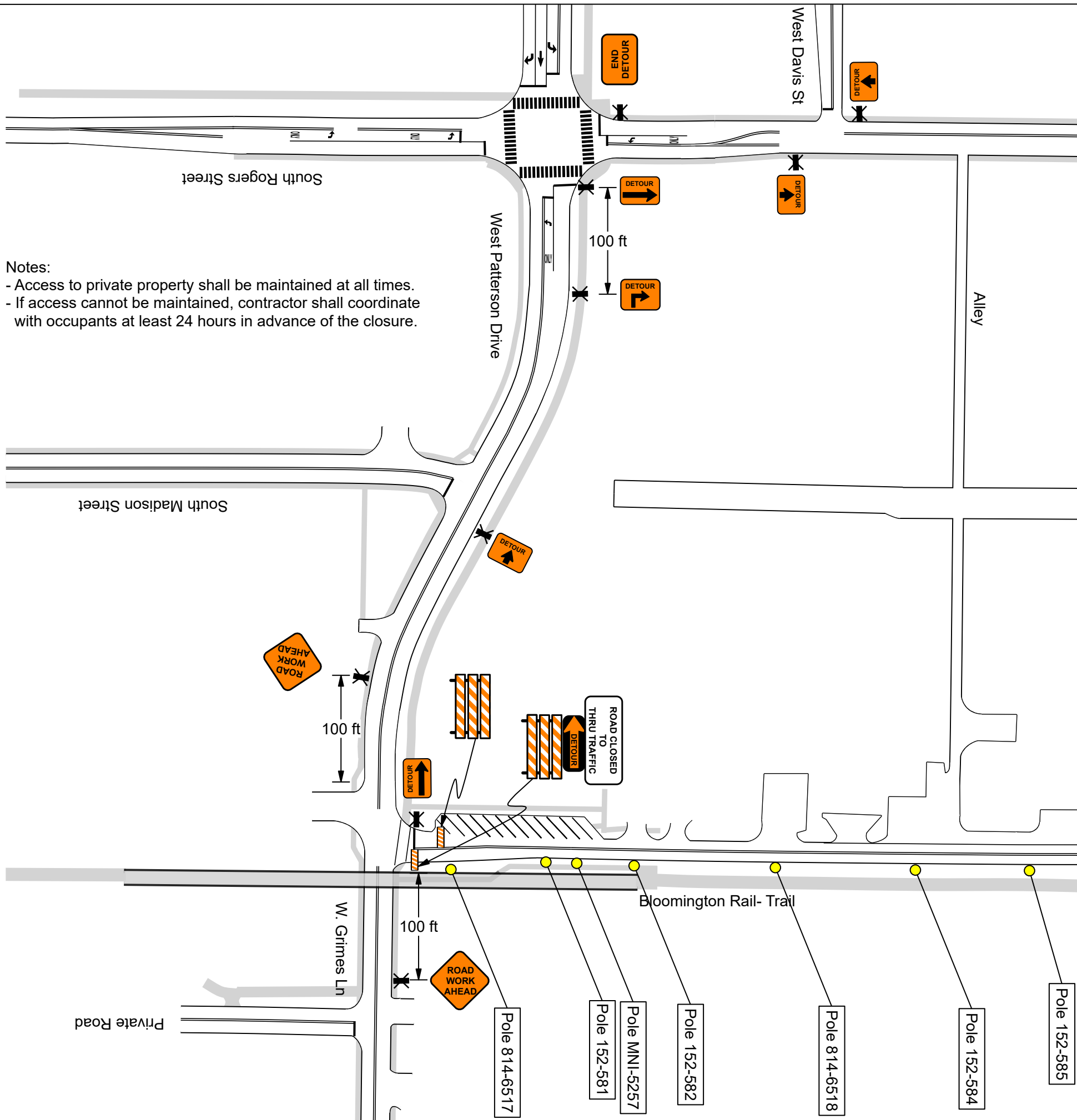

- Portable Sign Stand
- Type 3 Barricade
- Work Area

Match Line F - See Sheet 21



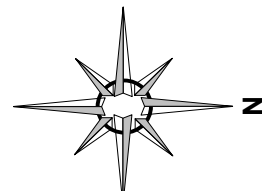

Notes:  
 - Access to private property shall be maintained at all times.  
 - If access cannot be maintained, contractor shall coordinate with occupants at least 24 hours in advance of the closure.

  
**Legend**  
 Portable Sign Stand  
 Type 3 Barricade  
 Work Area

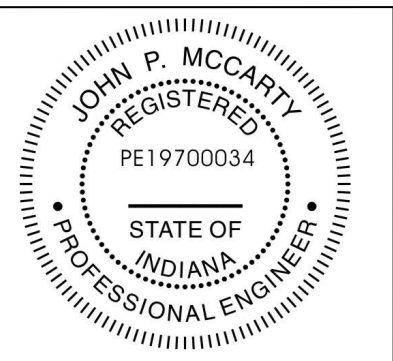

Professional Certification. I hereby certify that these documents were prepared or approved by me, and that I am a duly licensed professional engineer under the laws of the State of Indiana, License No. PE19700034, Expiration Date: 7/31/2024

  
**ORANGE BARREL ENGINEERS**  
 www.orangebarrelengineers.com  
 ORANGE BARREL ENGINEERS, P.C.  
 1469 North Magnolia Ave., Suite B,  
 Ocala FL 34475  
 317-758-7587

PREPARED FOR:  
**TNT Traffic Control**

PROJECT NAME:  
**Road Closures For Pole Replacement Various Locations**

PROJECT ADDRESS:  
**Madison Street and Morton Street  
 Bloomington, IN  
 Monroe County**

THESE DRAWINGS ARE THE PROPERTY OF TNT Traffic Control. THEY ARE INTENDED EXCLUSIVELY FOR USE ON THIS PROJECT ONLY. ANY RE-USE OF THESE PLANS WITHOUT THE EXPRESS WRITTEN CONSENT OF TNT Traffic Control IS PROHIBITED

ISSUED FOR: **Temporary Traffic Control** DATE: **1/5/2023**  
 Des. by: JPM  
 Drawn by: JPM

REVISION			
NO	DESCRIPTION	BY	DATE

SHEET TITLE:  
**Temporary Traffic Control**

SHEET NUMBER:  
**21 OF 27**



Professional Certification. I hereby certify that these documents were prepared or approved by me, and that I am a duly licensed professional engineer under the laws of the State of Indiana, License No. PE19700034, Expiration Date: 7/31/2024



**ORANGE BARREL ENGINEERS**  
www.orangebarrelengineers.com  
ORANGE BARREL ENGINEERS, P.C.  
1469 North Magnolia Ave., Suite B,  
Ocala FL 34475  
317-758-7587

PREPARED FOR:  
**TNT Traffic Control**

PROJECT NAME:  
**Road Closures For Pole Replacement Various Locations**

PROJECT ADDRESS:  
**Madison Street and Morton Street  
Bloomington, IN  
Monroe County**

THESE DRAWINGS ARE THE PROPERTY OF TNT Traffic Control. THEY ARE INTENDED EXCLUSIVELY FOR USE ON THIS PROJECT ONLY. ANY RE-USE OF THESE PLANS WITHOUT THE EXPRESS WRITTEN CONSENT OF TNT Traffic Control IS PROHIBITED

ISSUED FOR: **Temporary Traffic Control** DATE: **1/5/2023**  
Des. by: JPM  
Drawn by: JPM

REVISION			
NO	DESCRIPTION	BY	DATE

SHEET TITLE:  
**Temporary Traffic Control**

SHEET NUMBER:  
**22 OF 27**

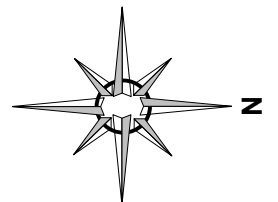
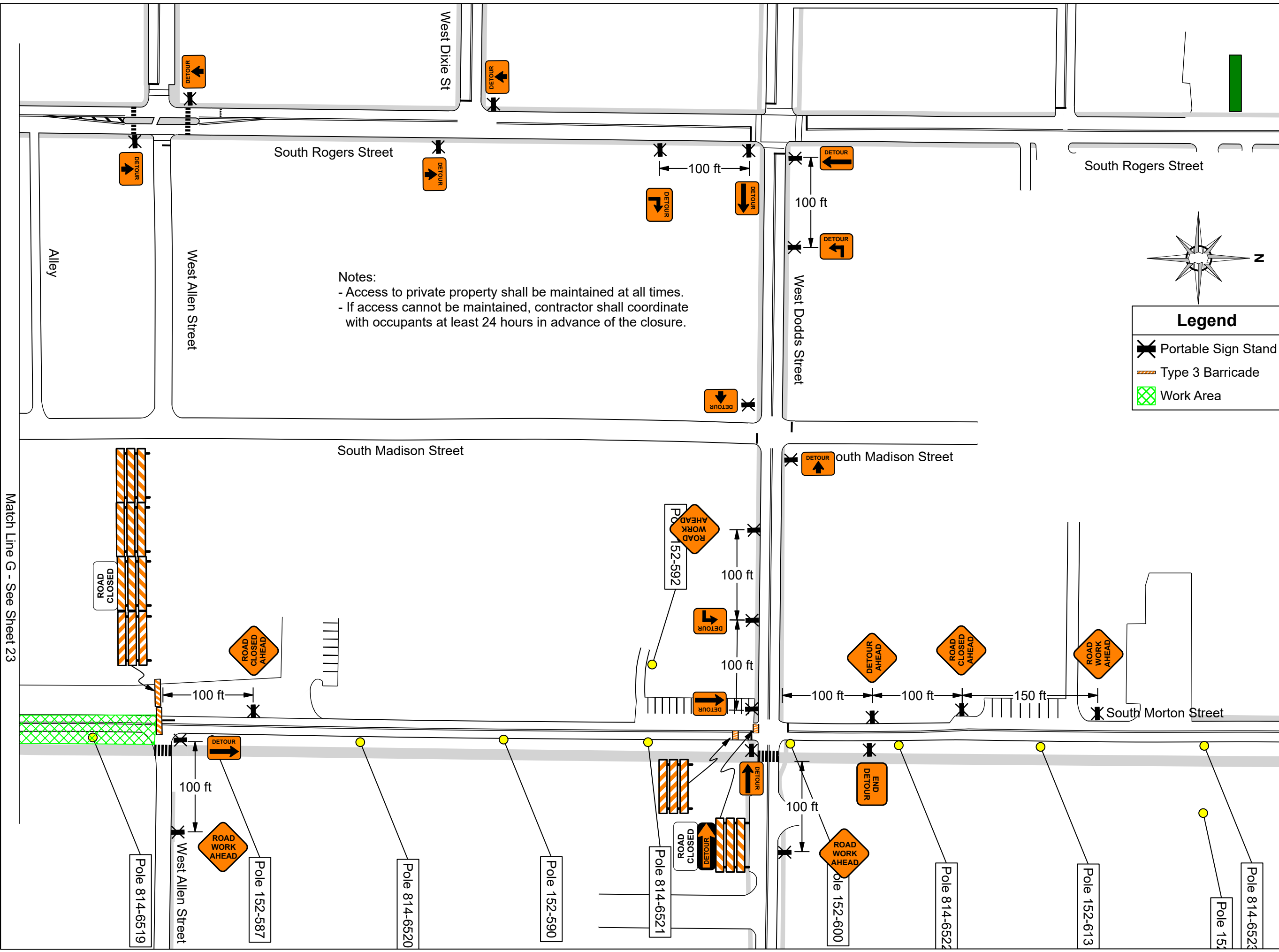

**Legend**

- Portable Sign Stand
- Type 3 Barricade
- Work Area

**Notes:**  
- Access to private property shall be maintained at all times.  
- If access cannot be maintained, contractor shall coordinate with occupants at least 24 hours in advance of the closure.

**Legend**



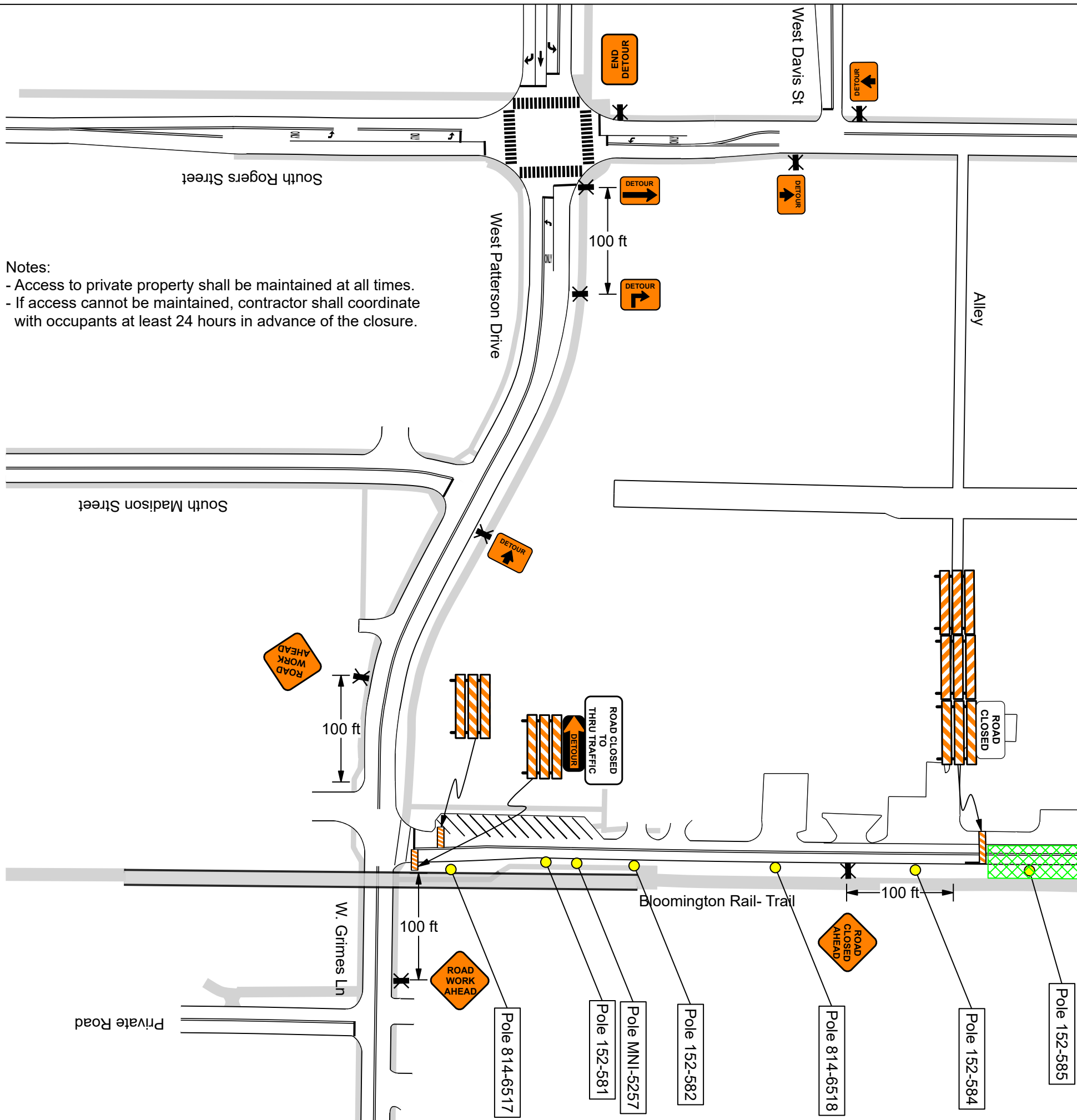

- Portable Sign Stand
- Type 3 Barricade
- Work Area

Match Line G - See Sheet 23

- Pole 814-6519
- Pole 152-587
- Pole 814-6520
- Pole 152-590
- Pole 814-6521
- Pole 152-600
- Pole 814-6522
- Pole 152-613
- Pole 152-613
- Pole 814-6523
- Pole 152-613
- Pole 814-6523

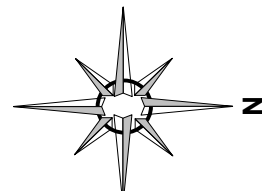

Notes:  
 - Access to private property shall be maintained at all times.  
 - If access cannot be maintained, contractor shall coordinate with occupants at least 24 hours in advance of the closure.

  
**Legend**  
 Portable Sign Stand  
 Type 3 Barricade  
 Work Area

Match Line G - See Sheet 22

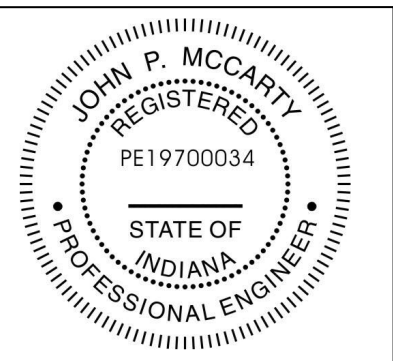

Professional Certification. I hereby certify that these documents were prepared or approved by me, and that I am a duly licensed professional engineer under the laws of the State of Indiana, License No. PE19700034, Expiration Date: 7/31/2024



ORANGE BARREL ENGINEERS, P.C.  
 1469 North Magnolia Ave., Suite B,  
 Ocala FL 34475  
 317-758-7587

PREPARED FOR:  
**TNT Traffic Control**

PROJECT NAME:  
**Road Closures For Pole Replacement Various Locations**

PROJECT ADDRESS:  
**Madison Street and Morton Street  
 Bloomington, IN  
 Monroe County**

THESE DRAWINGS ARE THE PROPERTY OF TNT Traffic Control. THEY ARE INTENDED EXCLUSIVELY FOR USE ON THIS PROJECT ONLY. ANY RE-USE OF THESE PLANS WITHOUT THE EXPRESS WRITTEN CONSENT OF TNT Traffic Control IS PROHIBITED

ISSUED FOR: **Temporary Traffic Control** DATE: **1/5/2023**  
 Des. by: JPM  
 Drawn by: JPM

REVISION			
NO	DESCRIPTION	BY	DATE

SHEET TITLE:  
**Temporary Traffic Control**

SHEET NUMBER:  
**23 OF 27**



Professional Certification. I hereby certify that these documents were prepared or approved by me, and that I am a duly licensed professional engineer under the laws of the State of Indiana, License No. PE19700034, Expiration Date: 7/31/2024



**ORANGE BARREL ENGINEERS**  
www.orangebarrelengineers.com

ORANGE BARREL ENGINEERS, P.C.  
1469 North Magnolia Ave., Suite B,  
Ocala FL 34475  
317-758-7587

PREPARED FOR:  
**TNT Traffic Control**

PROJECT NAME:  
**Road Closures For Pole Replacement Various Locations**

PROJECT ADDRESS:  
**Madison Street and Morton Street  
Bloomington, IN  
Monroe County**

THESE DRAWINGS ARE THE PROPERTY OF TNT Traffic Control. THEY ARE INTENDED EXCLUSIVELY FOR USE ON THIS PROJECT ONLY. ANY RE-USE OF THESE PLANS WITHOUT THE EXPRESS WRITTEN CONSENT OF TNT Traffic Control IS PROHIBITED

ISSUED FOR: **Temporary Traffic Control** DATE: **1/5/2023**

Des. by: JPM  
Drawn by: JPM

REVISION			
NO	DESCRIPTION	BY	DATE

SHEET TITLE:  
**Temporary Traffic Control**

SHEET NUMBER:  
**24 OF 27**

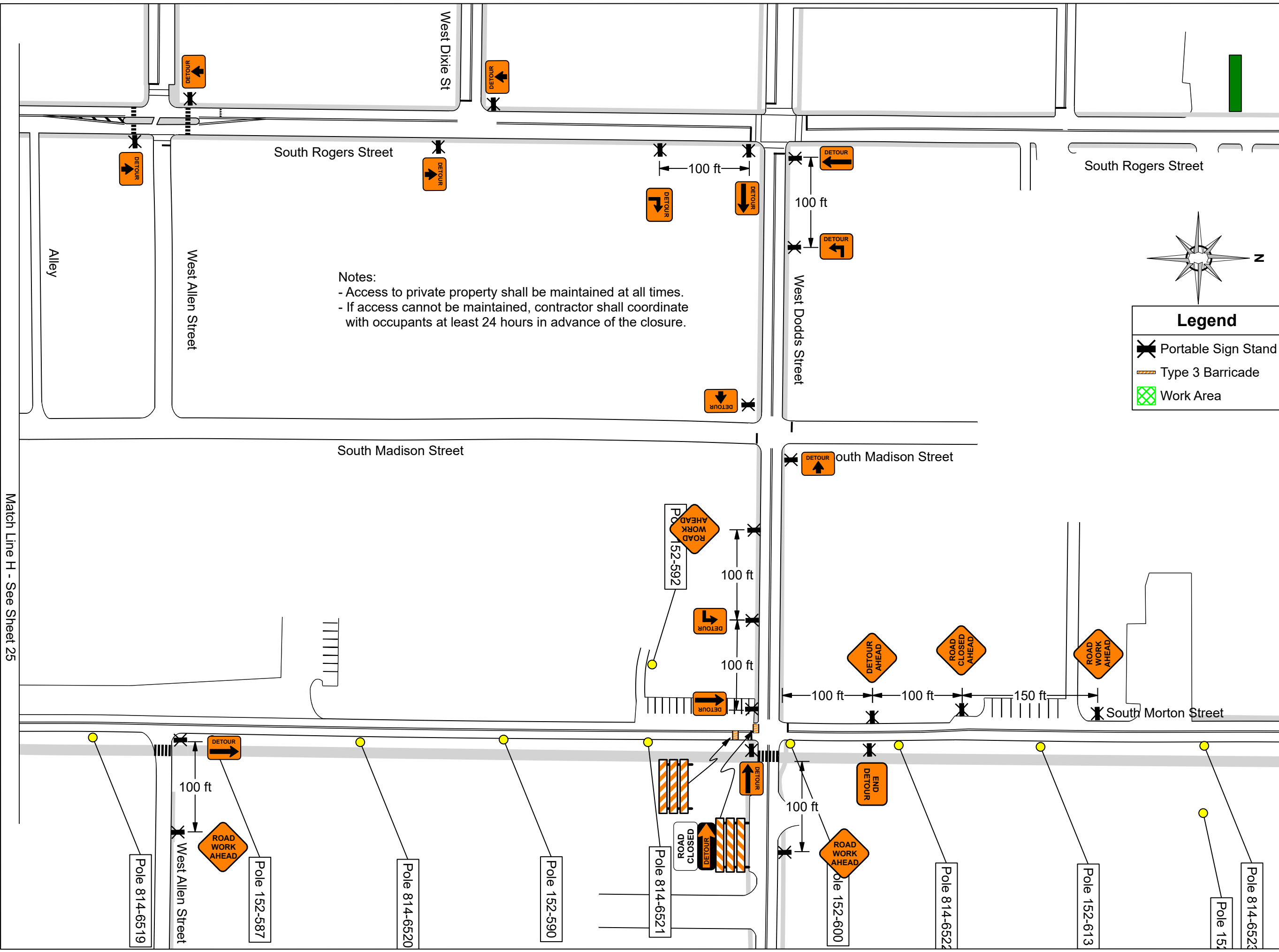

Notes:  
- Access to private property shall be maintained at all times.  
- If access cannot be maintained, contractor shall coordinate with occupants at least 24 hours in advance of the closure.

**Legend**



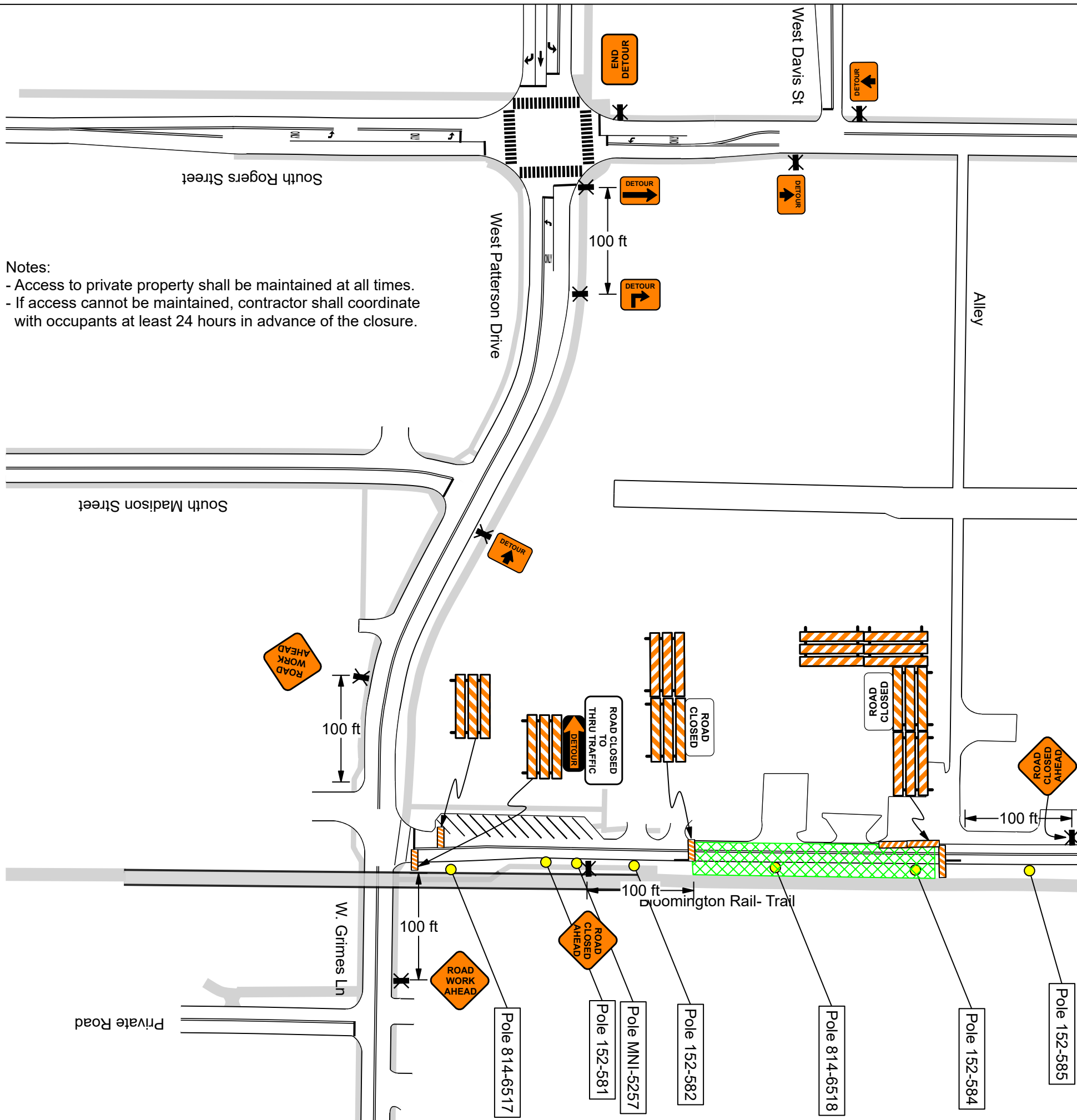

- Portable Sign Stand
- Type 3 Barricade
- Work Area

Match Line H - See Sheet 25



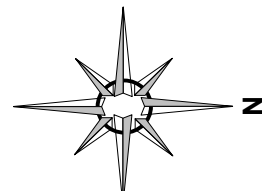

Notes:  
 - Access to private property shall be maintained at all times.  
 - If access cannot be maintained, contractor shall coordinate with occupants at least 24 hours in advance of the closure.

  
**Legend**  
 Portable Sign Stand  
 Type 3 Barricade  
 Work Area

Match Line H - See Sheet 24

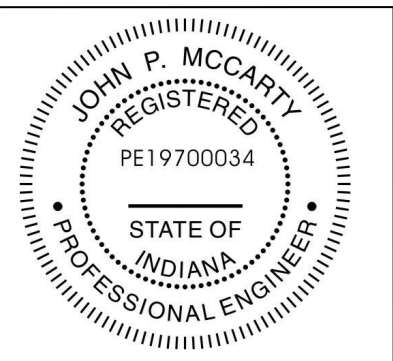

Professional Certification. I hereby certify that these documents were prepared or approved by me, and that I am a duly licensed professional engineer under the laws of the State of Indiana, License No. PE19700034, Expiration Date: 7/31/2024

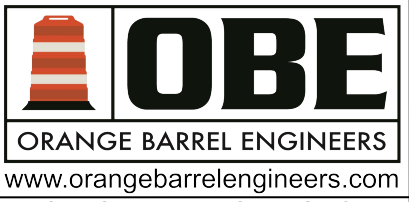

**ORANGE BARREL ENGINEERS, P.C.**  
 1469 North Magnolia Ave., Suite B,  
 Ocala FL 34475  
 317-758-7587

PREPARED FOR:  
**TNT Traffic Control**

PROJECT NAME:  
**Road Closures For Pole Replacement Various Locations**

PROJECT ADDRESS:  
**Madison Street and Morton Street  
 Bloomington, IN  
 Monroe County**

THESE DRAWINGS ARE THE PROPERTY OF TNT Traffic Control. THEY ARE INTENDED EXCLUSIVELY FOR USE ON THIS PROJECT ONLY. ANY RE-USE OF THESE PLANS WITHOUT THE EXPRESS WRITTEN CONSENT OF TNT Traffic Control IS PROHIBITED

ISSUED FOR: **Temporary Traffic Control** DATE: **1/5/2023**  
 Des. by: JPM  
 Drawn by: JPM

REVISION			
NO	DESCRIPTION	BY	DATE

SHEET TITLE:  
**Temporary Traffic Control**

SHEET NUMBER:  
**25 OF 27**



Professional Certification. I hereby certify that these documents were prepared or approved by me, and that I am a duly licensed professional engineer under the laws of the State of Indiana, License No. PE19700034, Expiration Date: 7/31/2024



**ORANGE BARREL ENGINEERS**  
www.orangebarrelengineers.com

ORANGE BARREL ENGINEERS, P.C.  
1469 North Magnolia Ave., Suite B,  
Ocala FL 34475  
317-758-7587

PREPARED FOR:  
**TNT Traffic Control**

PROJECT NAME:  
**Road Closures For Pole Replacement Various Locations**

PROJECT ADDRESS:  
**Madison Street and Morton Street  
Bloomington, IN  
Monroe County**

THESE DRAWINGS ARE THE PROPERTY OF TNT Traffic Control. THEY ARE INTENDED EXCLUSIVELY FOR USE ON THIS PROJECT ONLY. ANY RE-USE OF THESE PLANS WITHOUT THE EXPRESS WRITTEN CONSENT OF TNT Traffic Control IS PROHIBITED

ISSUED FOR: **Temporary Traffic Control** DATE: **1/5/2023**

Des. by: JPM  
Drawn by: JPM

REVISION			
NO	DESCRIPTION	BY	DATE

SHEET TITLE:  
**Temporary Traffic Control**

SHEET NUMBER:  
**26 OF 27**

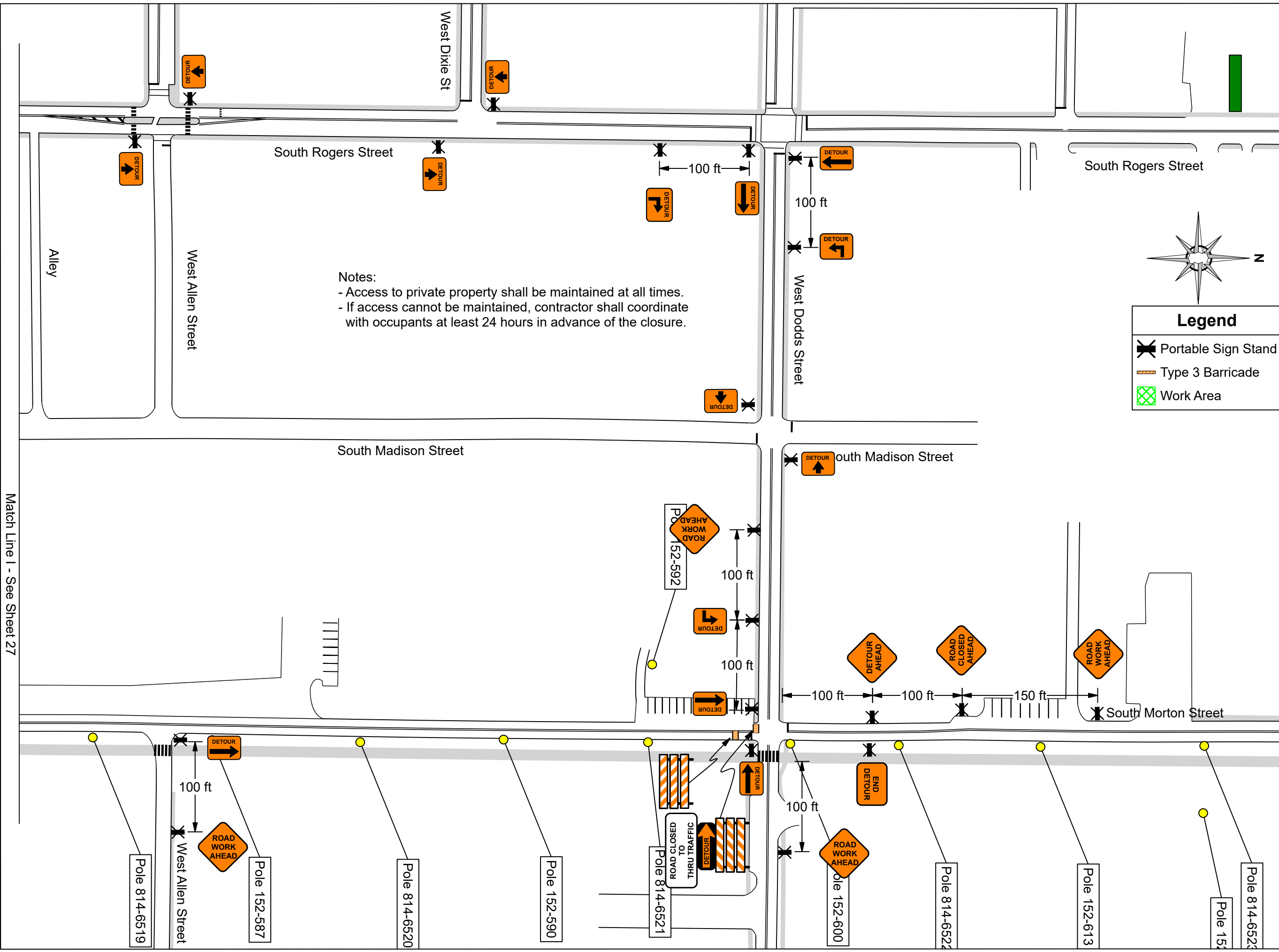

Notes:  
- Access to private property shall be maintained at all times.  
- If access cannot be maintained, contractor shall coordinate with occupants at least 24 hours in advance of the closure.

**Legend**



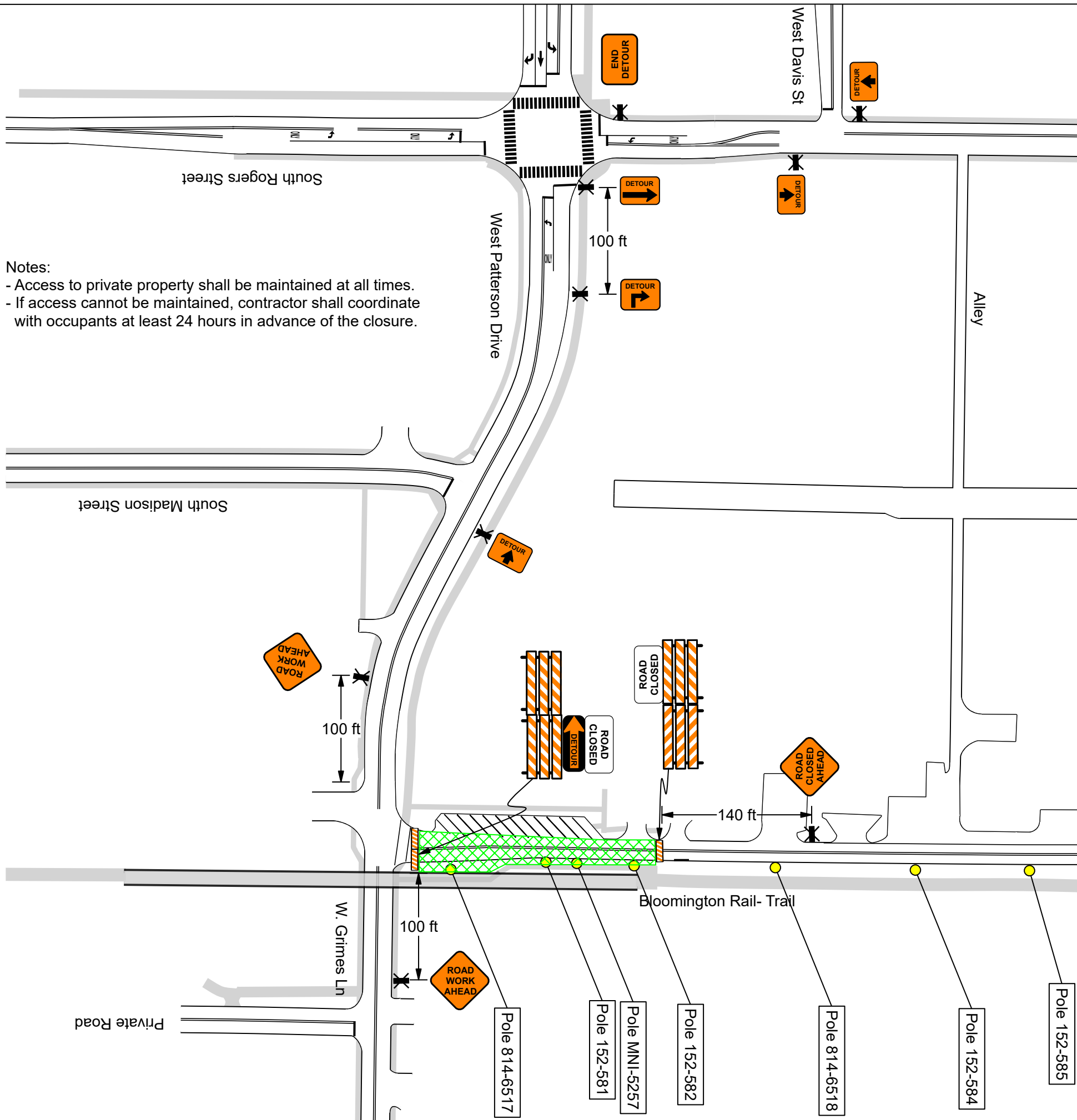

- ✂ Portable Sign Stand
- ▨ Type 3 Barricade
- ▨ Work Area

Match Line I - See Sheet 27



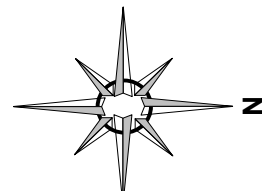

Notes:  
 - Access to private property shall be maintained at all times.  
 - If access cannot be maintained, contractor shall coordinate with occupants at least 24 hours in advance of the closure.

  
**Legend**  
 Portable Sign Stand  
 Type 3 Barricade  
 Work Area

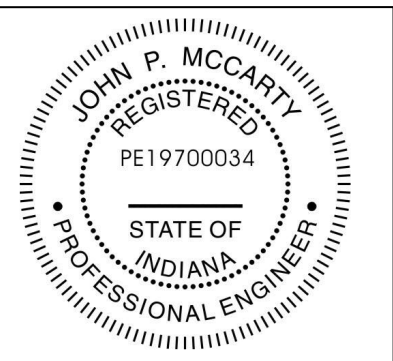

Professional Certification. I hereby certify that these documents were prepared or approved by me, and that I am a duly licensed professional engineer under the laws of the State of Indiana, License No. PE19700034, Expiration Date: 7/31/2024

  
**ORANGE BARREL ENGINEERS**  
 www.orangebarrelengineers.com  
 ORANGE BARREL ENGINEERS, P.C.  
 1469 North Magnolia Ave., Suite B,  
 Ocala FL 34475  
 317-758-7587

PREPARED FOR:  
**TNT Traffic Control**

PROJECT NAME:  
**Road Closures For Pole Replacement Various Locations**

PROJECT ADDRESS:  
**Madison Street and Morton Street  
 Bloomington, IN  
 Monroe County**

THESE DRAWINGS ARE THE PROPERTY OF TNT Traffic Control. THEY ARE INTENDED EXCLUSIVELY FOR USE ON THIS PROJECT ONLY. ANY RE-USE OF THESE PLANS WITHOUT THE EXPRESS WRITTEN CONSENT OF TNT Traffic Control IS PROHIBITED

ISSUED FOR: **Temporary Traffic Control** DATE: **1/5/2023**  
 Des. by: JPM  
 Drawn by: JPM

REVISION			
NO	DESCRIPTION	BY	DATE

SHEET TITLE:  
**Temporary Traffic Control**

SHEET NUMBER:  
**27 OF 27**

Match Line I - See Sheet 26



A B C D E F G H J K L M N P R S T

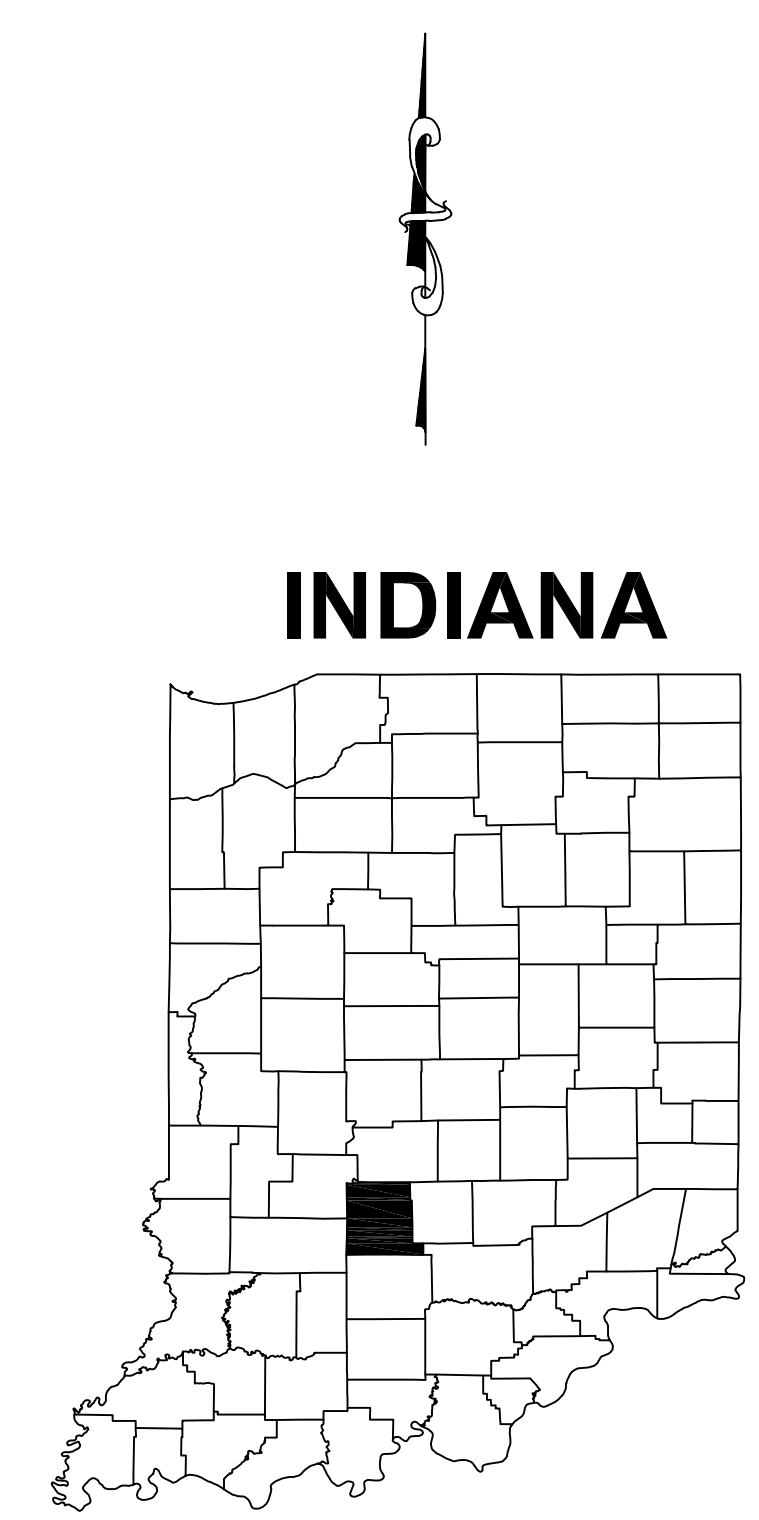
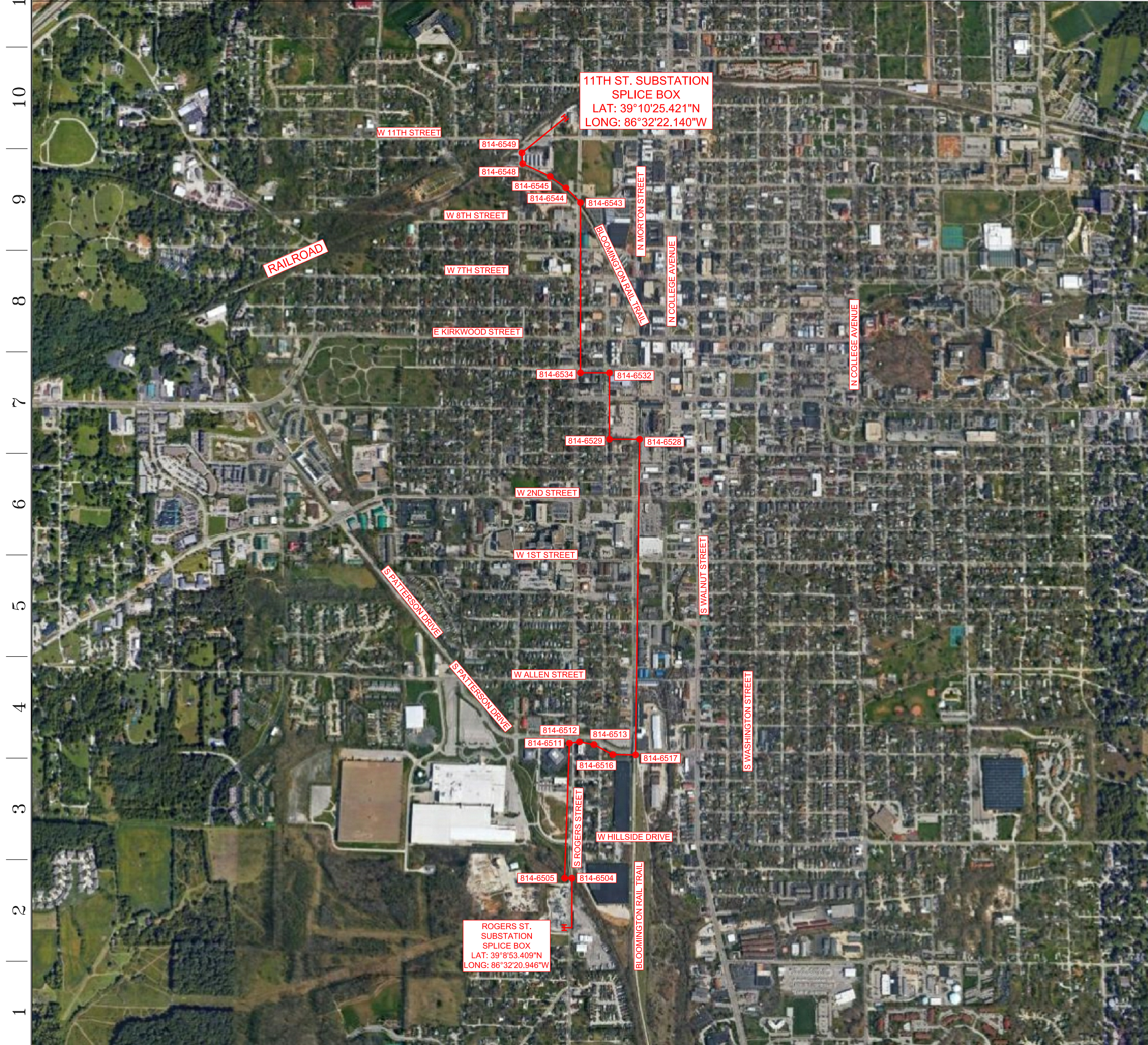

**INDIANA**

MONROE COUNTY

INDIANA SOUTH AREA  
 MONROE COUNTY  
 PERRY TOWNSHIP  
 CITY OF BLOOMINGTON  
 FUNDING PROJECT NUMBER: M200240  
 DRYF: M20024001  
 @MAX#: 37636633  
 LINE IDENT/FEEDER: 814.72  
 OPERATING NAME: 69171  
 ENGINEER: COMMONWEALTH ASSOCIATES, INC.  
 CONTACT: MELISSA OETERS (317) 838-2227  
 SPANS TEL/TV: COMCAST, AT&T, KOL, ZAYO, SMITHSVILLE  
 SPANS FOREIGN UTILITY:

WORK CODES:  
 INSTALL M20024001 LNSW  
 REMOVE M20024001 LNRM  
 MAINT M20024001 OM06

<p><b>FOR CONSTRUCTION</b> 7/31/20</p>	<p>SEAL:</p>	<p><small>THIS DRAWING OR BILL OF MATERIAL IS CONFIDENTIAL AND MAY NOT BE LOANED, REPRODUCED OR COPIED, EITHER WHOLLY OR IN PART, OR MADE PUBLIC IN ANY MANNER WITHOUT THE WRITTEN CONSENT OF DUKE ENERGY CORPORATION.</small></p>	<p>DRAFTED BY: JAM</p>	<input type="checkbox"/> PRELIMINARY APPROVAL	<p>FILENAME: blm to rogers phase 3 route map.dwg</p>
			<p>DESIGNED/ENGINEER: JTL</p>	<input type="checkbox"/> AS BUILT	<p>TITLE: ROUTE MAP BLM TO ROGERS ST. SUB-BLM 11TH ST. SUB.</p>
			<p>CHECKED BY: SAM</p>	<p>DATE _____</p>	<p>LOCATION: MONROE COUNTY, INDIANA</p>
			<p>DETAIL PROJECT NO: M20024001</p>		<p>SCALE: _____</p>
			<p>BM/FUNDING PROJECT: M200240</p>		<p>SCALE FACTOR: _____</p>
			<p>DATE ISSUED: 7/31/20</p>	<p>STA NO: _____</p>	<p>REV: _____</p>
				<p>DWG NO: SHEET 1 OF 1</p>	

A B C D E F G H J K L M N P R S T







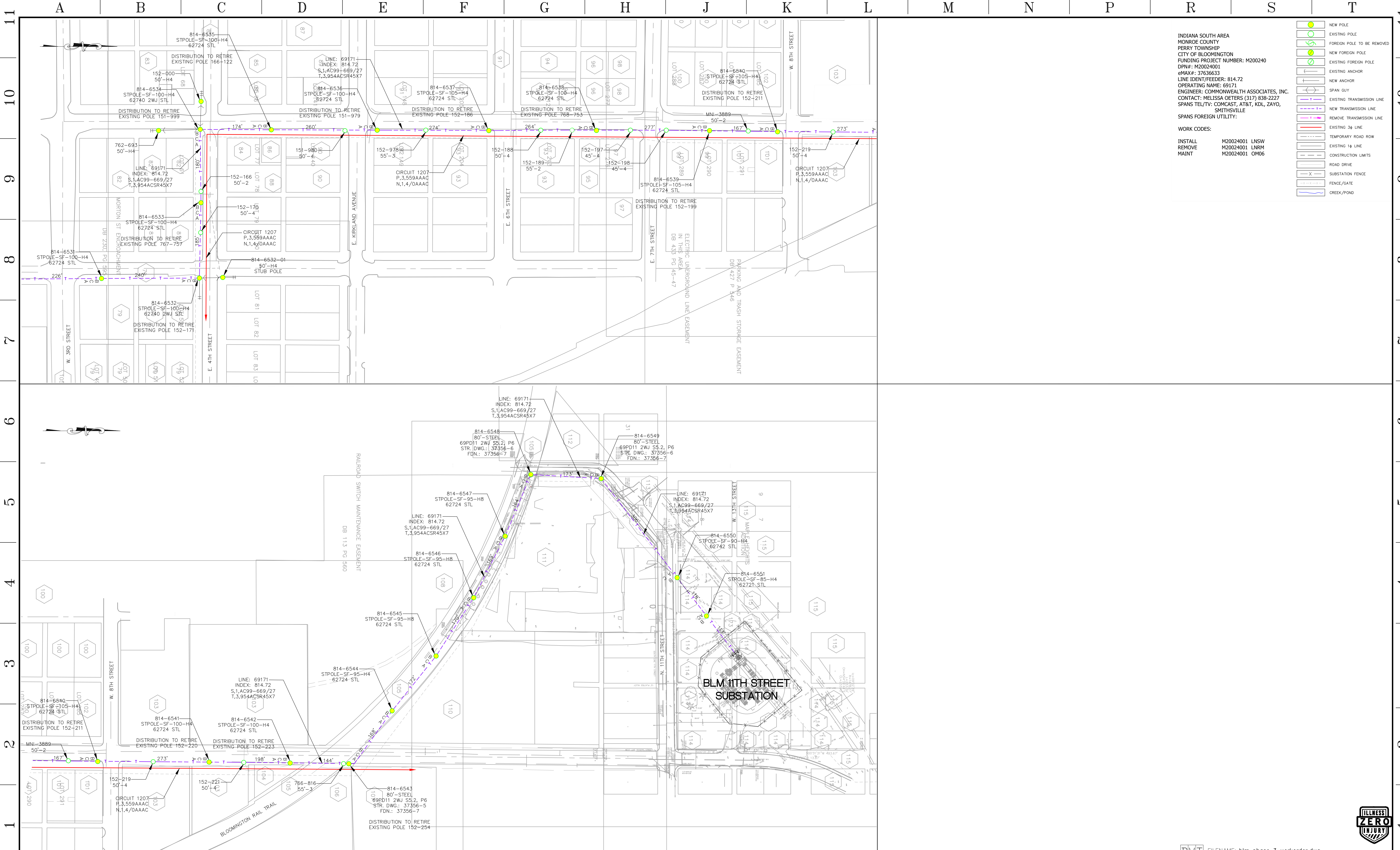

- INDIANA SOUTH AREA  
 MONROE COUNTY  
 PERRY TOWNSHIP  
 CITY OF BLOOMINGTON  
 FUNDING PROJECT NUMBER: M200240  
 DP##: M20024001  
 eMAX#: 37636633  
 LINE IDENT/FEEDER: 814.72  
 OPERATING NAME: 69171  
 ENGINEER: COMMONWEALTH ASSOCIATES, INC.  
 CONTACT: MELISSA OETERS (317) 838-2227  
 SPANS TEL/TY: COMCAST, AT&T, KDL, ZAYO, SMITHSVILLE  
 SPANS FOREIGN UTILITY:
- WORK CODES:  
 INSTALL M20024001 LNSW  
 REMOVE M20024001 LNRM  
 MAINT M20024001 OM06
- NEW POLE
  - EXISTING POLE
  - FOREIGN POLE TO BE REMOVED
  - EXISTING FOREIGN POLE
  - NEW FOREIGN POLE
  - EXISTING FOREIGN POLE
  - NEW ANCHOR
  - EXISTING ANCHOR
  - SPAN GUY
  - EXISTING TRANSMISSION LINE
  - NEW TRANSMISSION LINE
  - REMOVE TRANSMISSION LINE
  - EXISTING 36 LINE
  - TEMPORARY ROAD ROW
  - EXISTING 16 LINE
  - CONSTRUCTION LIMITS
  - ROAD DRIVE
  - SUBSTATION FENCE
  - FENCE/GATE
  - CREEK/POND

NOTE:  
 1. DISTRIBUTION CIRCUITS 1207 & 1208 ARE TO TRANSFER AT EXISTING ATTACHMENT HEIGHTS.

REV.	DATE	BY	CHK.	APP.	DESCRIPTION

FOR CONSTRUCTION  
 5/19/22

SEAL:

THIS DRAWING OR BILL OF MATERIAL IS CONFIDENTIAL AND MAY NOT BE LOANED, REPRODUCED OR COPIED, EITHER WHOLLY OR IN PART, OR MADE PUBLIC IN ANY MANNER WITHOUT THE WRITTEN CONSENT OF DUKE ENERGY CORPORATION.

DRAFTED BY: JAM	<input type="checkbox"/> PRELIMINARY
DESIGNED/ENGINEER: JTL	<input type="checkbox"/> APPROVAL
CHECKED BY: JTL	<input type="checkbox"/> AS BUILT
DATE: _____	DATE: _____
NAME: _____	NAME: _____
DETAIL PROJECT NO: M20024001	
GW/FUNDING PROJECT: M200240	
DATE ISSUED: 5/19/22	

DWT FILENAME: blm phase 3 workorder.dwg

TITLE:  
 WORK ORDER DRAWING  
 BLM TO ROGERS ST. SUB-BLM 11TH ST. SUB. PHASE III

LOCATION:  
 MONROE COUNTY, INDIANA

SCALE:  
 1"=100'

SCALE FACTOR: \_\_\_\_\_

STA NO: \_\_\_\_\_

REV: \_\_\_\_\_

DWG NO:  
 SHEET 2 OF 2



LHM PLS DWG 5/19/22 2:59 AM







## Board of Public Works Staff Report

---

<b>Project/Event:</b>	Request from The Standard at Bloomington, LLC for lane closure extension on E 14 <sup>th</sup> St
<b>Staff Representative:</b>	Paul Kehrberg
<b>Petitioner/Representative:</b>	Eric Schulte, Landmark Construction
<b>Date:</b>	January 31, 2023

---

**Report:** The Standard at Bloomington, LLC is continue work on the redevelopment project on E 14<sup>th</sup> St between N Walnut At and N Dunn St. This lane closure was previously approved at the August 16, 2022 BPW meeting, and they are now asking for a one month extension. The original approval was until January 31, 2023 They are requesting a single lane closure on E 14<sup>th</sup> St from N Washington St to N Dunn St. E 14<sup>th</sup> St would be one way westbound during this closure. The lane closure will allow for the safe unloading and handling of construction materials adjacent to the site. There will be barriers with fencing above to keep a separation between construction activities and traffic. The on street parking will remain open along the north side of E 14<sup>th</sup> St.

On August 9<sup>th</sup> The Standard at Bloomington, LLC hosted a public informational meeting to gather input for area property owners. City staff also attended this meeting.

The dates of the lane closure extension will be from February 1 to February 28, 2023.



Todd M. Borgman, P.L.S.  
Katherine E. Stein, P.E.  
Don J. Kocarek, R.L.A. Stephen  
L. Smith, Founder

January 14th, 2023

City of Bloomington Board of Public Works  
401 N Morton St Suite 120  
Bloomington, IN 47404

Dear Members of the Board of Public Works,

The Standard at Bloomington, LLC is requesting to extend the closure of half of East 14<sup>th</sup> Street between North Washington Street and North Dunn Street. This request would extend the closure until February 28<sup>th</sup>, 2023, and traffic would be permitted westbound only on East 14<sup>th</sup> Street. The reason for this closure is to allow for the safe unloading and handling of construction materials adjacent to the project site.

The contractor will control traffic by following a maintenance of traffic plan included with this submittal for your review.

We appreciate your consideration of this request and are happy to answer any questions regarding these proposed closures.

Regards,

Kendall Knoke  
Smith Design Group, Inc. 812-336-6536  
Ext. 3 [kknoke@smithdginc.com](mailto:kknoke@smithdginc.com)

2755 E Canada Dr Suite 101  
Bloomington, Indiana 47401  
812-336-6536  
[smithdginc.com](http://smithdginc.com)

Page 1 of 2



Todd M. Borgman, P.L.S.



Todd M. Borgman, P.L.S.  
Katherine E. Stein, P.E.  
Don J. Kocarek, R.L.A.  
Stephen L. Smith, Founder

2/28/2023 January 24<sup>th</sup>, 2023

Dear Nearby Property Owner,

The Standard at Bloomington, LLC is continuing to perform work associated with the redevelopment of the former Brownstone Terrace Apartments site. As part of those efforts, The Standard at Bloomington, LLC is requesting to extend the closure of the eastbound lane of East 14<sup>th</sup> Street between North Washington Street and North Dunn Street. This request will extend the closure from an end date of 1/31/2023 to 2/28/2023 . The reason for this closure is to allow for the safe unloading and handling of construction materials adjacent to the project site.

The request to restrict public rights-of-way for this project will be heard by the City of Bloomington Board of Public Works on **Tuesday January 31st, 2023 at 5:30pm**. The meeting will be held in the City Council Chambers (Room #115) of City Hall (Showers Building) located at 401 N Morton St, Bloomington, IN 47404. A virtual option is available and the link/phone numbers can be found by visiting the City of Bloomington Board of Public Works website at <https://bloomington.in.gov/boards/public-works>. The public will have the opportunity to provide comments regarding traffic interruptions and temporary road closures at this time.

Anyone not able to attend this public meeting may submit comments via phone or email to Eric Schulte at 814-571-3450 or Eric.Schulte@LandmarkProperties.com. These comments will be read at the Board of Public Works meeting.

Anyone with concerns during construction may contact Eric Schulte, Project Manager – Landmark Construction at 814-571-3450 or Eric.Schulte@LandmarkProperties.com.

Todd M. Borgman, P.L.S.  
Katherine E. Stein, P.E.  
Don J. Kocarek, R.L.A.  
Stephen L. Smith, Founder

Regards,

Kendall Knoke  
Smith Design Group, Inc.  
812-336-6536 Ext. 3  
kknoke@smithdginc.com



Project Location Map, North is Up, N.T.S.





REVISIONS	BY	DATE

DESIGNED BY	KCK, DJK
DRAWN BY	KCK, DJK
CHECKED BY	KES
DATE	4/22/21

JOB NUMBER	5919
SHEET	1 OF 1
DATE	08/10/2022
MOT PLAN FOR E 14TH ST ONE WAY CLOSURE	

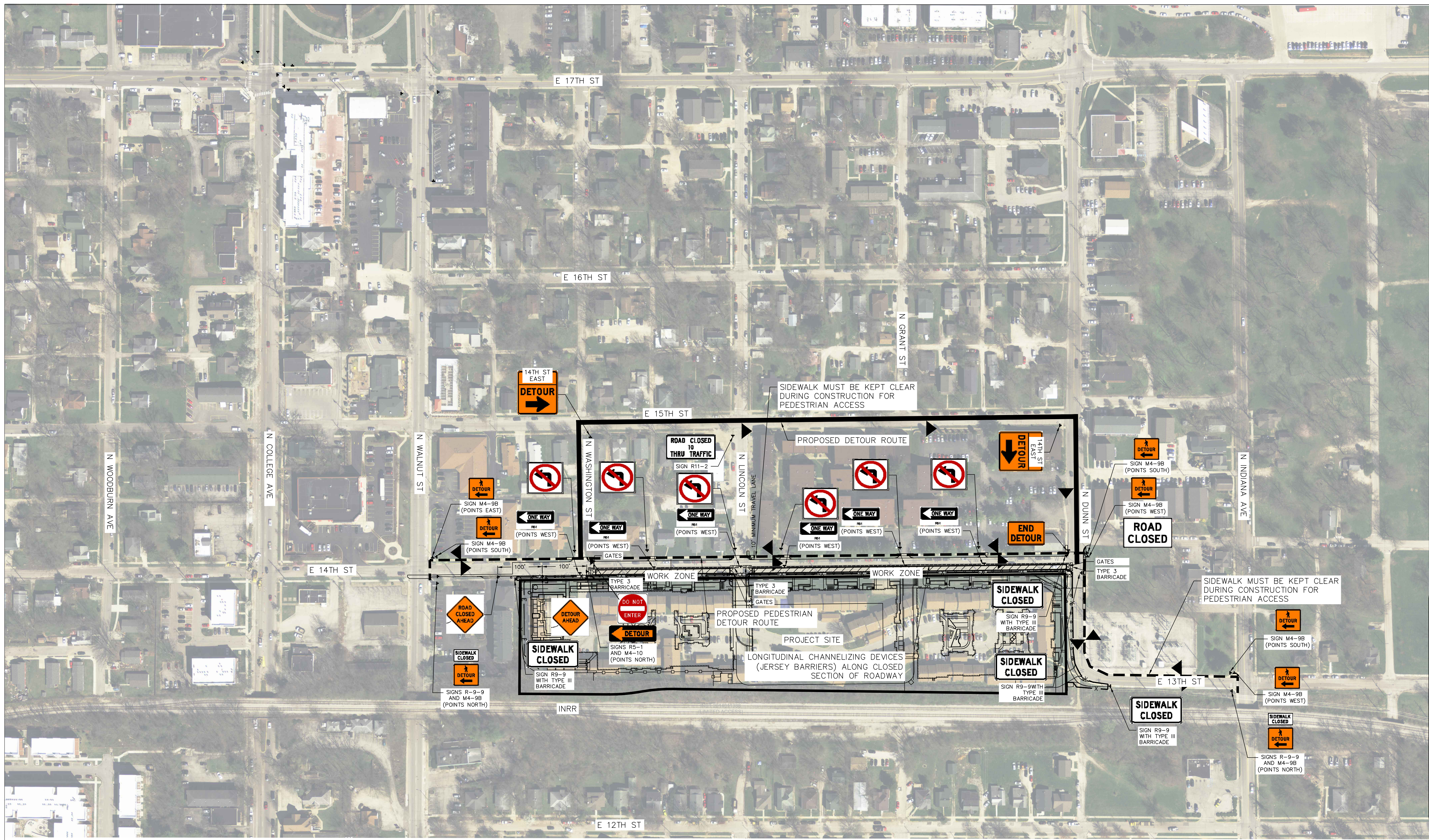

**MAINTENANCE OF TRAFFIC PLAN DURING E 14TH ST HALF CLOSURE (ONE WAY WEST ONLY)**

**MAINTENANCE OF TRAFFIC LEGEND**

- CHANNELIZING DEVICE (DRUM)
- LONGITUDINAL CHANNELIZING DEVICE
- ↔ DETOUR ROUTE WITH DIRECTIONAL ARROWS
- X— CONSTRUCTION FENCE

**MAINTENANCE OF TRAFFIC NOTES**

1. CONTRACTOR IS RESPONSIBLE FOR MAINTENANCE OF TRAFFIC. ALL MAINTENANCE OF TRAFFIC MUST BE IN ACCORDANCE WITH THE LATEST REVISION OF THE INDIANA MANUAL OF UNIFORM TRAFFIC CONTROL DEVICES (MUTCD) AND SHALL MEET CITY OF BLOOMINGTON MUNICIPAL CODE.
2. PRIOR TO THE START OF CONSTRUCTION CONTRACTOR SHALL COORDINATE ON-SITE MEETING WITH CITY OF BLOOMINGTON PLANNING AND TRANSPORTATION AND PUBLIC WORKS TO REVIEW WORK IN THE PUBLIC RIGHT-OF-WAY AND IMPLEMENTATION OF THE TRAFFIC CONTROL PLAN AND SIDEWALK CLOSURE.
3. MAINTAIN ACCESS FROM E 14TH ST TO FIRE HYDRANTS AT ALL TIMES DURING CONSTRUCTION.
4. AFTER WORKING HOURS, ROADWAY MAY BE RESTORED TO TWO DIRECTIONAL TRAFFIC WITH PLATES OR ANOTHER METHOD APPROVED BY CITY OF BLOOMINGTON ENGINEERING. SIGNS INDICATING ROAD CLOSURE ARE TO BE COVERED IF THE ROADWAY IS REOPENED AFTER WORKING HOURS.

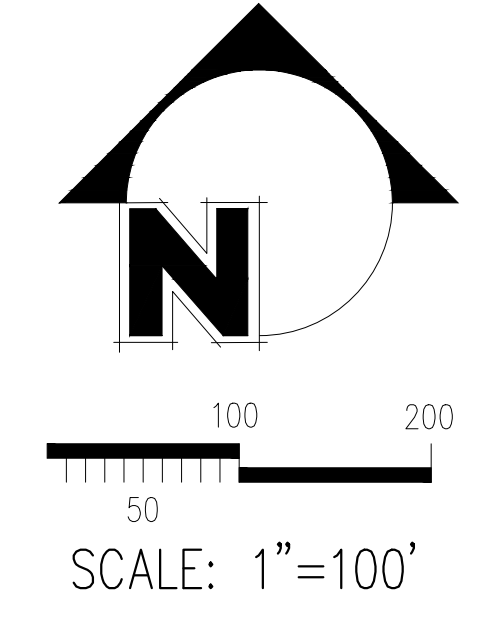





# CITY OF BLOOMINGTON

## RIGHT-OF-WAY USE PERMIT APPLICATION

401 N Morton Street, Suite 130  
P.O. Box 100  
Bloomington, IN 47402

Phone: (812) 349-3913  
Fax: (812) 349-3520  
Email:  
engineering@bloomington.in.gov

ADDRESS OR NEAREST ADDRESS  
OF RIGHT OF WAY ACTIVITY: \_\_\_\_\_

### A. APPLICANT/AGENT INFORMATION:

APPLICANT NAME: Eric Schulte - Project Manger - Lanmdark Urban Construction

E-MAIL: eric.schulte@landmarkproperties.com

COMPANY: Lanmdark Urban Construction

ADDRESS: 315 Oconee Street

CITY, STATE, ZIP: Athens, GA 30601

24-HR EMERGENCY CONTACT NAME: Edward Tipton

24-HR CONTACT PHONE #: 480-793-8351

ADDITIONAL INFO:

\*INSURANCE & BOND MUST BE ON FILE WITH THE CITY BEFORE PERMIT WILL BE ISSUED

### \*\*SUBCONTRACTOR INFORMATION\*\*

(LIST ALL COMPANIES WORKING UNDER PRIMARY CONTRACTOR

PERMIT) COMPANY NAME: RH Marlin Inc.

IS THIS A  CBU\*  COUNTY\*  IU\*  NP\* PROJECT?

PROJECT NAME: \_\_\_\_\_

PROJECT #: \_\_\_\_\_

PROJECT MGR.: \_\_\_\_\_

PROJECT MGR. #: \_\_\_\_\_

\*CBU = CITY OF BLOOMINGTON UTILITIES \*COUNTY = MONROE COUNTY

\*IU = INDIANA UNIVERSITY \*NP= NOT-FOR-PROFIT AGENCY

### B. WORK DESCRIPTION:

POD/DUMPSTER  CRANE  SCAFFOLDING  CONSTRUCTION USE\*  GAS  ELECTRIC  SANITARY SEWER  WATER  
 TELECOM  OTHER (EXPLAIN): \_\_\_\_\_

\*EXCAVATION, LONG TERM USE FOR STORAGE OF MATERIAL/EQUIPMENT/WALKAROUND

### WILL RIGHT OF WAY BE USED/CLOSED/BLOCKED?

STREET NAME(S): E. 14th Street - East Bound Lane Closure

SIDEWALK\*  ROAD CLOSURE  LANE CLOSURE:  1  2  3

BIKE LANE  BUS STOP  ON-STREET PARKING\*  ALLEY

\*SIDEWALK CLOSURES FOR A PERIOD OR PERIODS TOTALING 24HRS OR MORE SHALL INSTALL A WALKAROUND UNLESS OTHERWISE APPROVED DURING REVIEW

\*ON-STREET PARKING THAT IS METERED OR NEIGHBORHOOD PERMIT ZONED MUST BE COORDINATED WITH PARKING SERVICES

START DATE: 2/1/2023 END DATE: 2/28/2023 # OF DAYS\*: 28

REQUESTED CLOSURE HOURS: 24Hrs AM - \_\_\_\_\_ PM

\*non-standard hours may not be allowed near schools, on arterials, or other circumstances and are subject to approval during the permitting process BMC 14.09.040 allows work from 6 AM to 10 PM without violating the noise ordinance (7AM to 9PM for pneumatic hammers)

ADDITIONAL NOTES:

WILL THERE BE EXCAVATIONS (LENGTH, WIDTH, AND DEPTH OR LxWxD IN FEET)? NO

LxWxD OF PAVEMENT\* EXCAVATIONS: \_\_\_\_\_

\*PAVEMENT INCLUDES: IN OR UNDER CONCRETE, OR ASPHALT INCLUDING CURBS

LxWxD OF NON-PAVEMENT\* EXCAVATIONS: \_\_\_\_\_

\*DIRT, GRASS, GRAVEL, LANDSCAPE AREA OR OTHER UNPAVED SURFACE

LINEAL FT OF BORE\*:

\*BORE PITS SHALL BE CALCULATED AS LxWxD EXCAVATIONS

# OF POLE INSTALL/REMOVAL: \_\_\_\_\_

LxWxD OF SIDEWALK RECONSTRUCTION\*:

\*CONCRETE OR ASPHALT SIDEWALK/PATH BEING IMPROVED/REPLACED

LxWxD OF SIDEWALK NEW CONSTRUCTION\*:

\*CONCRETE OR ASPHALT SIDEWALK/PATH THAT IS NEW INFRASTRUCTURE

# OF DRIVEWAY INSTALLATIONS: \_\_\_\_\_

### C. INDEMNIFICATION AGREEMENT:

The petitioner/applicant hereby agrees to hold harmless, defend and to indemnify the City of Bloomington from or against all claims, action, damages and expenses, including but not limited to reasonable attorney's fees or any alleged injury and/or death to any person or damage to any property arising, or alleged to have arisen out of any act of commission or omission on the part of the petitioner/applicant, his/her heirs, successors, or assigns regardless of whether such acts are the direct or indirect result of the public right-of-way use pursuant to this permit grant.

I AFFIRM, UNDER THE PENALTIES FOR PERJURY, THAT THE FOREGOING REPRESENTATIONS ARE TRUE.

PRINT NAME: Eric M. Schulte

SIGNATURE: [Signature]

DATE: 1/24/2023



TO SUBMIT A LOCATE REQUEST 24 HRS A DAY, 7 DAYS A WEEK CALL 811 OR 800-382-5544  
CALL 2 WORKING DAYS BEFORE YOU DIG. ITS THE LAW.

For Administration Use Only (applicable to CLOSURE approval)

Approved By: \_\_\_\_\_  Staff  BPW  City Engineer  PW Director Date: \_\_\_\_\_

Staff Representative: \_\_\_\_\_ Phone#: \_\_\_\_\_ Date: \_\_\_\_\_



## Board of Public Works Staff Report

---

**Project/Event:** Fox Construction  
**Staff Representative:** Jason Kerr  
**Petitioner/Representative:** Tony Fox  
**Date:** January 31st, 2023

---

**Report:** Fox Construction Company, Inc. is the General Contractor building the New Rockets Fuel Gas/Convenient facility on West 2nd Street. As part of the project Fox Construction Company, Inc. will be replacing the existing sidewalk along 2nd Street and Patterson Drive. The new walk will be placed slightly further inward off road than the existing one, a new curb will be installed along the 2nd Street side.

As a result of this work, Fox Construction Company, Inc. is requesting the temporary closure of the east bound lane on 2nd Street and south bound lane of Patterson Drive, as well as the sidewalks along this same area. In accordance with the attached management of traffic plan. Fox Construction Company, Inc. is requesting this closure from June 1, 2023 to June 30,



FOX CONSTRUCTION COMPANY, INC  
6931 South Old State Road 37 • Bloomington, IN 47403

January 16, 2023

*Via Electronic Delivery*

Board of Public Works  
City of Bloomington  
401 North Morton Street  
Bloomington, IN 47404

Re: Rockets Fuel Project, 1207 West 2<sup>nd</sup> Street Requested Lane Restrictions

Dear Board Members:

Fox Construction Company, Inc. is the General Contractor building the New Rockets Fuel Gas/Convenient facility at 1207 West 2<sup>nd</sup> Street. As part of the project Fox Construction Company, Inc. will be replacing the existing Right-O-Way sidewalk along 2<sup>nd</sup> Street and Patterson Drive. The new walk will be placed slightly further inward off road than the existing one, a new curb will be installed along the 2<sup>nd</sup> Street side.

As a result of this work, Fox Construction Company, Inc. is requesting the temporary closure of the east bound lane on 2<sup>nd</sup> Street and south bound lane of Patterson Drive, as well as the sidewalks along this same area. In accordance with the attached management of traffic plan. Fox Construction Company, Inc. is requesting this closure from June 1, 2023 to June 30, 2023.

Fox Construction Company, Inc. will coordinate and communicate this work with the City of Bloomington Planning, Engineering, and Traffic Department. Therefore, Fox Construction Company, Inc. respectfully requests the Board of Public Works approve the restriction closure references above from June 1, 2023 to June 30, 2023.

Kind regards,

A handwritten signature in black ink, appearing to read "Anthony J. Fox".

Anthony J. Fox  
President/Fox Construction Company, Inc.





# CITY OF BLOOMINGTON RIGHT-OF-WAY USE PERMIT APPLICATION

401 N Morton Street, Suite 130  
P.O. Box 100  
Bloomington, IN 47402

Phone: (812) 349-3913  
Fax: (812) 349-3520  
Email:  
engineering@bloomington.in.gov

ROW EXCAVATION  ROW USE

ADDRESS OF ROW ACTIVITY: \_\_\_\_\_

<b>A. APPLICANT/AGENT INFORMATION:</b> APPLICANT NAME: <u>Fox Construction Company, Inc.</u> E-MAIL: <u>tony@foxconstructionco.com</u> COMPANY: <u>Fox Construction Company, Inc.</u> ADDRESS: <u>6931 South Old State Road 37</u> CITY, STATE, ZIP: <u>Bloomington, IN 47403</u> 24-HR EMERGENCY CONTACT NAME: <u>Tony Fox</u> 24-HR CONTACT PHONE #: <u>(812) 327-0149</u> INSURANCE #*: _____ COMPANY: _____ BOND #*: <u>HSA-MW-5054</u> COMPANY: <u>Hudson Ins Co</u> <small>* INSURANCE &amp; BOND MUST BE ON FILE WITH THE CITY BEFORE PERMIT WILL BE ISSUED</small>	<b>D. TRAFFIC CONTROL DEVICES*:</b> <input checked="" type="checkbox"/> CONES <input type="checkbox"/> ARROWBOARD <input checked="" type="checkbox"/> LIGHTED BARRELS <input type="checkbox"/> TYPE 3 BARRICADES <input checked="" type="checkbox"/> FLAGGERS <input type="checkbox"/> BPD OFFICER <small>*PROVIDING MUTCD COMPLIANT TEMPORARY TRAFFIC CONTROL DEVICES AND MAINTENANCE OF TRAFFIC (MOT) PLAN IS YOUR RESPONSIBILITY AND REQUIRED See page 3 for additional MOT resources; the graph paper can be used for your MOT site plan if needed or you can submit a separate sheet</small>
<b>**SUBCONTRACTOR INFORMATION**</b> <small>(LIST ALL COMPANIES WORKING UNDER PRIMARY CONTRACTOR PERMIT)</small> COMPANY NAME: <u>Fox Construction Co, Inc./Flynn Excavating</u>	<b>E. METERED PARKING SPACES NEEDED: <input type="checkbox"/> Y <input type="checkbox"/> N</b> <small>IT IS THE RESPONSIBILITY OF THE APPLICANT TO RESERVE PARKING METER(S) APPLICATION LOCATED: <a href="https://bloomington.in.gov/transportation/parking/">https://bloomington.in.gov/transportation/parking/</a> moving OR CONTACT PARKING SERVICES WITH QUESTIONS AT (812)349-3436</small>
<b>B. WORK DESCRIPTION:</b> <input type="checkbox"/> POD/DUMPSTER <input type="checkbox"/> CRANE <input type="checkbox"/> SCAFFOLDING <input checked="" type="checkbox"/> CONSTRUCTION USE* (EXPLAIN): <u>Sidewalk Demolition &amp; New Sidewalk</u> <small>*EXCAVATION, LONG TERM USE FOR STORAGE OF MATERIAL/EQUIPMENT/WALKAROUND</small>	<b>F. IS THIS A <input type="checkbox"/> CBU* <input type="checkbox"/> COUNTY* <input type="checkbox"/> IU* <input type="checkbox"/> NP* PROJECT?</b> PROJECT NAME: <u>Rocket Fuel Station</u> PROJECT #: _____ PROJECT MGR.: <u>Tony Fox/Fox Construction Co., Inc.</u> PROJECT MGR. #: <u>(812) 327-0149</u> <small>*CBU = CITY OF BLOOMINGTON UTILITIES *COUNTY = MONROE COUNTY *IU= INDIANA UNIVERSITY *NP= NOT-FOR-PROFIT AGENCY</small>
<b>C. RIGHT OF WAY TO BE USED/CLOSED:</b> STREET NAME 1: <u>West 2nd Street</u> 1ST INTERSECTING STREET NAME: <u>No streets, lanes, or</u> 2ND INTERSECTING STREET NAME: <u>sidewalks closed</u> <input type="checkbox"/> ROAD CLOSURE <input type="checkbox"/> LANE CLOSURE 1 <input type="checkbox"/> 2 <input type="checkbox"/> 3 <input type="checkbox"/> <input checked="" type="checkbox"/> SIDEWALK* <input type="checkbox"/> BIKE LANE <input type="checkbox"/> OTHER TRANSIT STOP? <input type="checkbox"/> Y <input type="checkbox"/> N PARKING LANE(S)** <input type="checkbox"/> Y <input type="checkbox"/> N <small>**NON-METERED</small> START DATE: <u>06/01/2022</u> ENDDATE: <u>06/30/2023</u> # OF DAYS*: _____ <u>Approximately 30 days total</u>	<b>G. EXCAVATIONS:</b> SQ FT OF PAVEMENT* EXCAVATIONS : <u>640</u> <small>*PAVEMENT INCLUDES: IN OR UNDER CONCRETE, OR ASPHALT INCLUDING CURBS</small> SQ FT OF NON-PAVEMENT* EXCAVATIONS: <u>3940</u> <small>*DIRT, GRASS, GRAVEL, LANDSCAPE AREA OR OTHER UNPAVED SURFACE</small> LINEAL FT OF BORE*: <u>100 Linear Feet</u> <small>*BORE PITS SHALL BE CALCULATED AS SQ FT EXCAVATIONS</small> # OF POLE INSTALLATIONS/REMOVAL: <u>N/A</u> SQ FT OF SIDEWALK RECONSTRUCTION*: <u>210 Sq. Ft.</u> <small>*CONCRETE OR ASPHALT SIDEWALK/PATH BEING IMPROVED/REPLACED</small> SQ FT OF SIDEWALK NEW CONSTRUCTION*: <u>1050 Sq. Ft.</u> <small>*CONCRETE OR ASPHALT SIDEWALK/PATH THAT IS NEW INFRASTRUCTURE</small> #RESIDENTIAL DRIVEWAY INSTALLATION: <u>N/A</u>
STREET NAME 2: <u>Patterson</u> 1ST INTERSECTING STREET NAME: _____ 2ND INTERSECTING STREET NAME: _____ <input type="checkbox"/> ROAD CLOSURE <input type="checkbox"/> LANE CLOSURE 1 <input type="checkbox"/> 2 <input type="checkbox"/> 3 <input type="checkbox"/> <input checked="" type="checkbox"/> SIDEWALK* <input type="checkbox"/> BIKE LANE <input type="checkbox"/> OTHER TRANSIT STOP? <input type="checkbox"/> Y <input type="checkbox"/> N PARKING LANE(S)** <input type="checkbox"/> Y <input type="checkbox"/> N <small>**NON-METERED</small> START DATE: _____ END DATE: _____ # OF DAYS*: _____ <small>*SIDEWALK CLOSURES FOR A PERIOD OR PERIODS TOTALING 24HRS OR MORE SHALL INSTALL A WALKAROUND UNLESS OTHERWISE APPROVED DURING REVIEW</small>	 TO SUBMIT A LOCATE REQUEST 24 HRS A DAY, 7 DAYS A WEEK CALL 811 OR 800-382-5544 CALL 2 WORKING DAYS BEFORE YOU DIG. ITS THE LAW.
<b>STANDARD CLOSURE HOURS MON-FRI*: 9:00 AM - 3:00 PM &amp; 6:00 PM - 9:00 PM</b> STANDARD CLOSURE HOURS <input type="checkbox"/> *NON-STANDARD CLOSURE HOURS <input type="checkbox"/> REQUESTED CLOSURE HOURS: _____ AM - _____ PM <small>*non-standard hours may not be allowed near schools, on arterials, or other circumstances and are subject to approval during the permitting process          BMC 14.09.040 allows work from 6 AM to 10 PM without violating the noise ordinance (7AM to 9PM for pneumatic hammers)</small>	<b>H. INDEMNIFICATION AGREEMENT:</b> The petitioner/applicant hereby agrees to hold harmless, defend and to indemnify the City of Bloomington from or against all claims, action, damages and expenses, including but not limited to reasonable attorney's fees or any alleged injury and/or death to any person or damage to any property arising, or alleged to have arisen out of any act of commission or omission on the part of the petitioner/applicant, his/her heirs, successors, or assigns regardless of whether such acts are the direct or indirect result of the public right-of-way use pursuant to this permit grant. I AFFIRM, UNDER THE PENALTIES FOR PERJURY, THAT THE FOREGOING REPRESENTATIONS ARE TRUE. PRINT NAME: _____ SIGNATURE: _____ DATE: _____

For Administration Use Only (applicable to CLOSURE approval)

Approved By: \_\_\_\_\_  BPW  City Engineer  Director Date: \_\_\_\_\_

Staff Representative: \_\_\_\_\_ Phone#: \_\_\_\_\_ Date: \_\_\_\_\_





**MAINTENANCE OF TRAFFIC NOTES**

- 1. THIS MOT PLAN WAS DEVELOPED USING THE LATEST EDITION OF THE INDIANA MANUAL ON UNIFORM TRAFFIC CONTROL DEVICES. THE CONTRACTOR SHALL IMPLEMENT TEMPORARY TRAFFIC SETUP AND MAINTENANCE IN ACCORDANCE WITH THE LATEST EDITION OF THE INDIANA MANUAL ON UNIFORM TRAFFIC CONTROL DEVICES.
- 2. ALL WORK IS TO BE IN ACCORDANCE WITH ALL STATE AND LOCAL REGULATIONS.
- 3. ALL PERMITS ARE TO BE OBTAINED BY THE CONTRACTOR PRIOR TO THE START OF CONSTRUCTION.
- 4. EXISTING UTILITIES ON SITE SHALL BE RELOCATED AS REQUIRED. CONTRACTOR SHALL PAY ALL COSTS ASSOCIATED WITH RELOCATION.
- 5. SAFE, CLEARLY MARKED PEDESTRIAN AND VEHICULAR ACCESS TO ALL ADJACENT PROPERTIES MUST BE MAINTAINED THROUGHOUT THE CONSTRUCTION PROCESS.
- 6. ALL TEMPORARY TRAFFIC CONTROL DEVICES REPRESENTED ON THIS PLAN SHALL BE PLACED AND SETUP BEFORE THE 'WORK SPACE AREA' CONSTRUCTION IS BEGUN

revisions:

**BBB**  
BYNUM FANYO & ASSOCIATES, INC.  
528 north walnut street  
(812) 332-8030

ARCHITECTURE  
CIVIL ENGINEERING  
PLANNING  
Bloomington, Indiana  
(812) 339-2990 (Fax)

certified by:

**PROPOSED  
ROCKET FUELS CONVENIENCE STORE  
& GAS STATION**  
1207 & 1209 WEST 2ND STREET  
BLOOMINGTON, INDIANA 47403

title: MAINTENANCE OF TRAFFIC PLAN

designed by: DJB  
drawn by: DJB  
checked by: JSF  
sheet no: C1  
project no.: 402154

SCALE: 1"=30'

**NOTE TO CONTRACTOR**

CONTRACTOR SHALL VERIFY ALL UTILITY LOCATIONS & DEPTHS AND NOTIFY ENGINEER OF ANY INACCURACIES IN LOCATION OR ELEVATION OR ANY CONFLICTS PRIOR TO & AFTER ANY EXCAVATION. NO PAYMENT SHALL BE MADE TO CONTRACTOR FOR UTILITY DESTRUCTION OR UNDERGROUND CHANGES REQUIRED DUE TO CONFLICTING ELEVATIONS.



## Board of Public Works Staff Report

---

**Project/Event:** Atlantic Engineering Group (AEG)  
**Staff Representative:** Jason Kerr  
**Petitioner/Representative:** Bret Simons  
**Date:** January 31st, 2023

---

**Report:** AEG is requesting lane closures and sidewalk closures in multiple locations of their project work areas. This request is to accommodate work on fiber installation via boring and aerial fiber installation. There will be traffic control placed within each area while work is going on, we're estimating 4 weeks per project area.

AEG has supplied various maintenance of traffic plans for all work. They are also placing door hangers for public notice to property owners about scope of their work and contact information for if there are any issues. (see packet for details).

AEG is requesting for 3 area projects to be granted through this BPW meeting. The following areas include...

E Queens Way	North to south, this is between E Moores Pk and Wimbledon In West to east, this is between S Oxford Dr and S Montclair Ave
S Maxwell St	North to south, this is between Viva Dr and Azelea Ln West to east, this is between Huntington Pl and S High St
S High St	North to south, this is between Meadowbluff Ct and E Winslow Rd West to east, this is between Wexley Rd and E Rock Creek Dr



P.O. Box 349 | Buford, Georgia 30515  
Main Office: (706)654-2298  
[www.aeg.cc](http://www.aeg.cc)

To: City of Bloomington – Engineering Department  
Subject: City of Bloomington Right of Way Application

Dear Board Members,

Atlantic Engineering Group is planning a large FTTH project across the entire City of Bloomington. This work will take place at different locations throughout the year. In order to facilitate these up coming projects, AEG is respectfully requesting access the to ROW as planned out in the submitted permits.

Traffic control plans will be attached to each permit. No long-term road closures or sidewalk closures are expected. Signs and flaggers will be present when needed and move with the project as it moves throughout the city. The areas will all be identified on the plans we submit to the cities Engineering Department.

Proper door hangers will be placed prior to the construction starting in a particular area. The door hangers will provide information about the construction and contact information if any issues arise.

Bret Simons  
Project Coordinator  
Atlantic Engineering Group





## Fiber Optic Internet is Coming to Your Neighborhood!

Over the next several weeks there will be construction crews in your area building a new fiber optic network. Fiber is the fastest and most reliable technology to deliver internet and Wi-Fi services.

Before we begin building, we must determine the location of existing underground utilities.

Construction areas will be marked with flags and paint that should remain in place for the duration of construction.

Please feel free to mark any private underground facilities that you believe are in the right of way. Examples of private facilities are: Sprinkler systems, dog fences, private gas line, pool systems, etc..

For additional information please call  
(812)-269-8805.

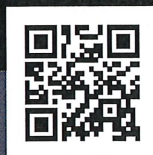





**Fiber Internet is coming  
to Bloomington!**

**You can subscribe now!**

## **Get the Fastest Internet in Town**

- ✓ Same Speeds Up and Down
- ✓ Ultimate Gaming with No Lag
- ✓ Stream without Buffering
- ✓ Video Chats without Interruption
- ✓ Use All Your Devices, All at the Same Time — No Problem!



**GigabitNow**  
**INDIANA**

Internet How It Is Meant To Be

[www.GigabitNowIndiana.com](http://www.GigabitNowIndiana.com)

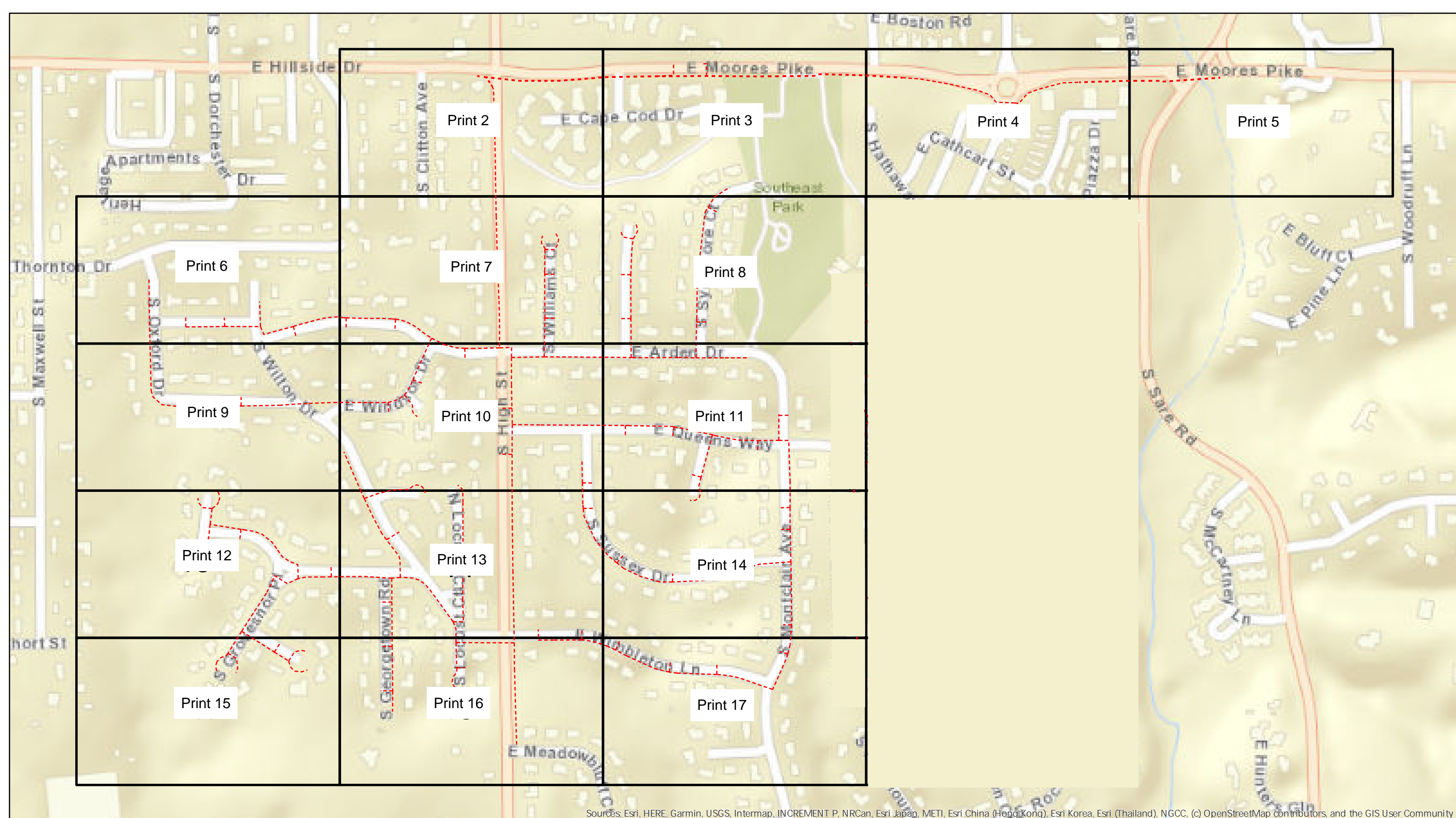

Sources: Esri, HERE, Garmin, USGS, Intermap, INCREMENT P, NRCan, Esri Japan, METI, Esri China (Hong Kong), Esri Korea, Esri (Thailand), NGCC, (c) OpenStreetMap contributors, and the GIS User Community



Legend BLC02a\_F13\_E Queens Way

- Overhead Strand
- - - Conduit
- Grids

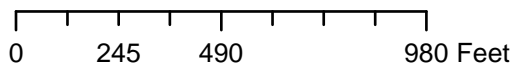

City of Bloomington, IN Permit:  
Design View

INI	BY	DATE	DESCRIPTION



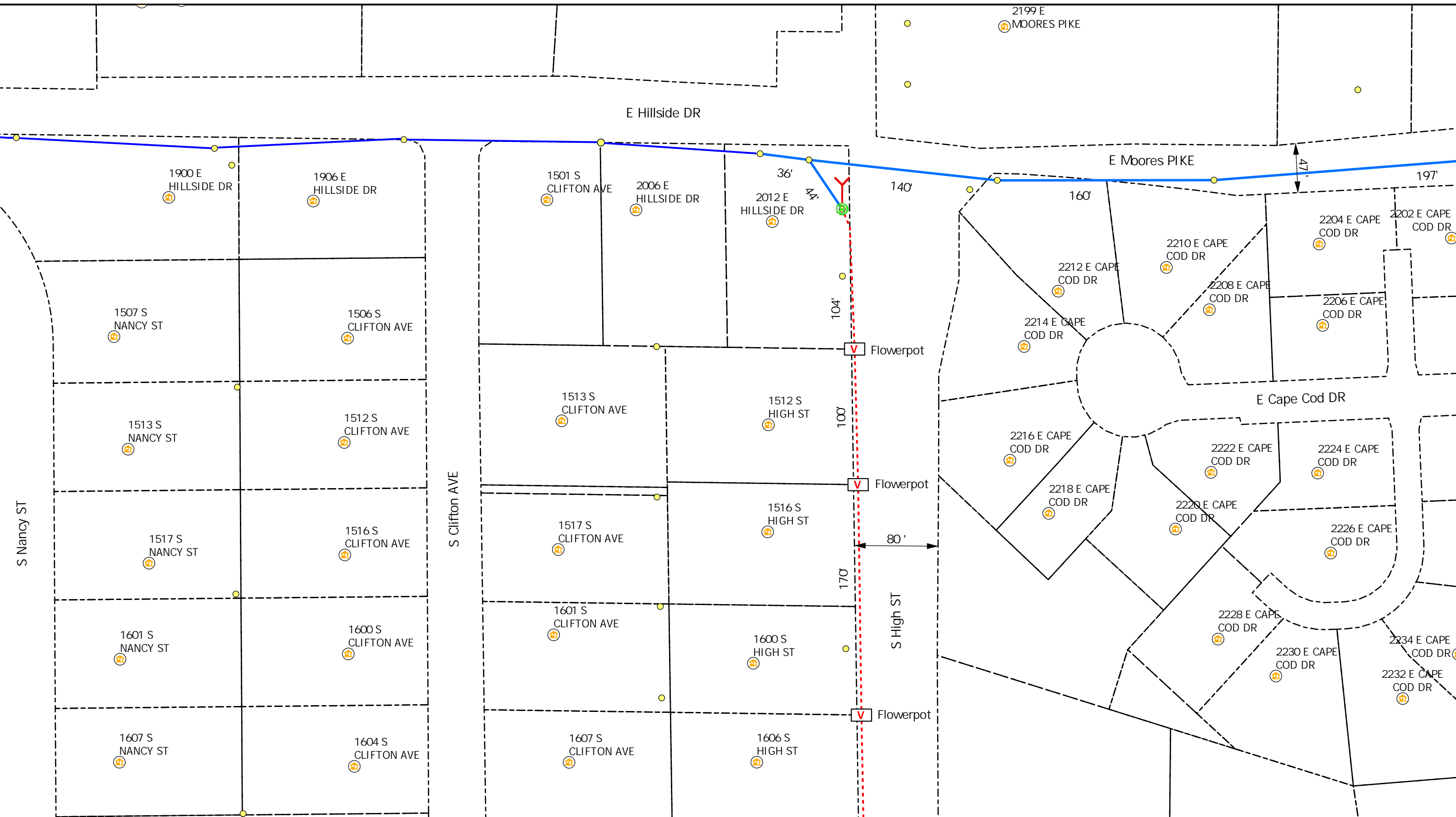

**Legend**

- Poles
- Bloomington\_Parcels
- Vaults
- Risers
- Overhead Strand
- Address
- Conduit
- Anchor
- Sidewalk
- Grids

All Flowerpots 12" DIA

**3**

City of Bloomington, IN Permit:  
Design View

INI	BY	DATE	DESCRIPTION

**Indiana 811**  
Print 2 of 17

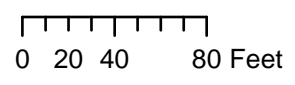
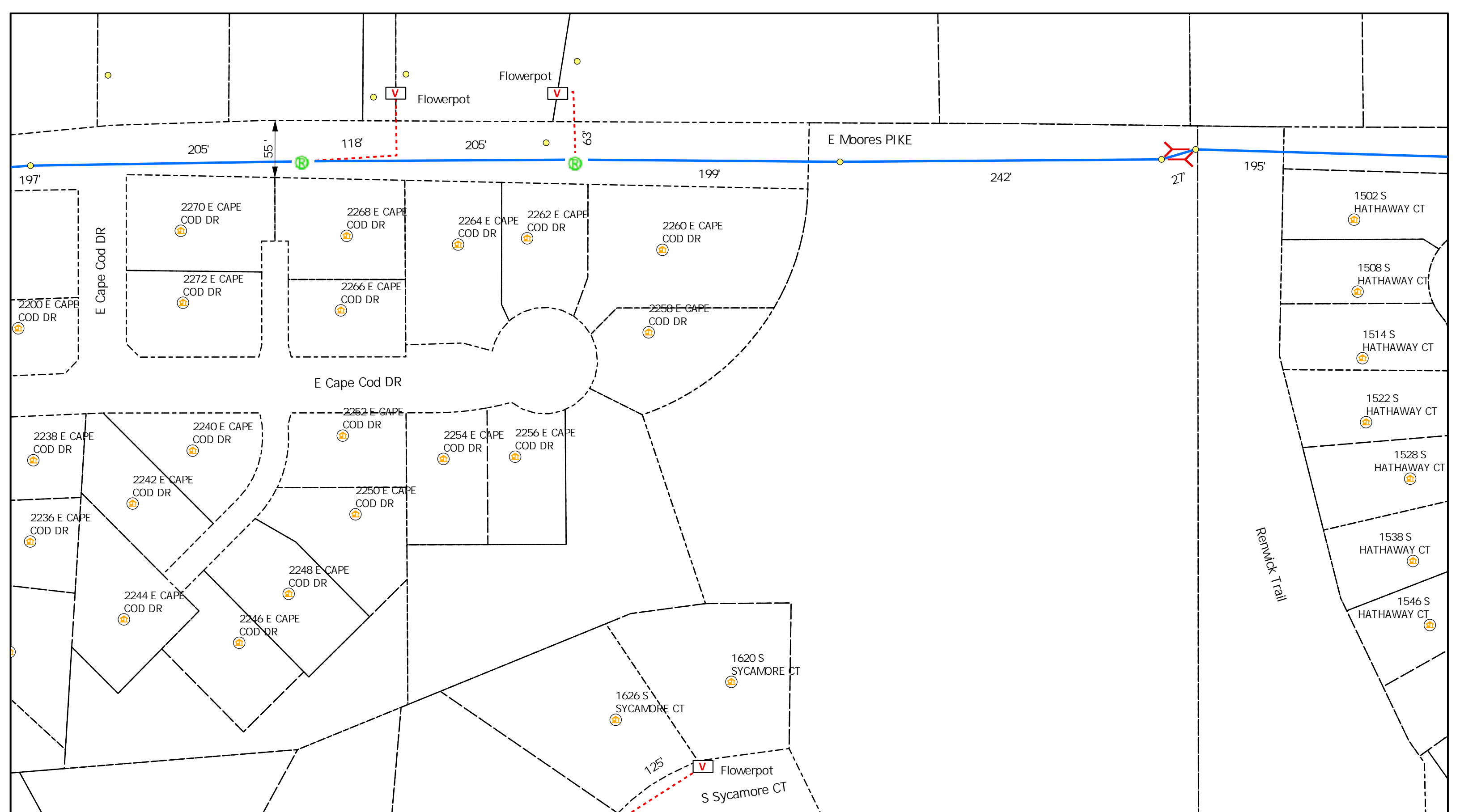

**Legend**

- Poles
- Vaults
- Overhead Strand
- Conduit
- Bloomington\_Parcels
- Risers
- Address
- Anchor
- Sidewalk
- Grids

All Flowerpots 12" DIA

**3**

City of Bloomington, IN Permit:  
Design View

INI	BY	DATE	DESCRIPTION





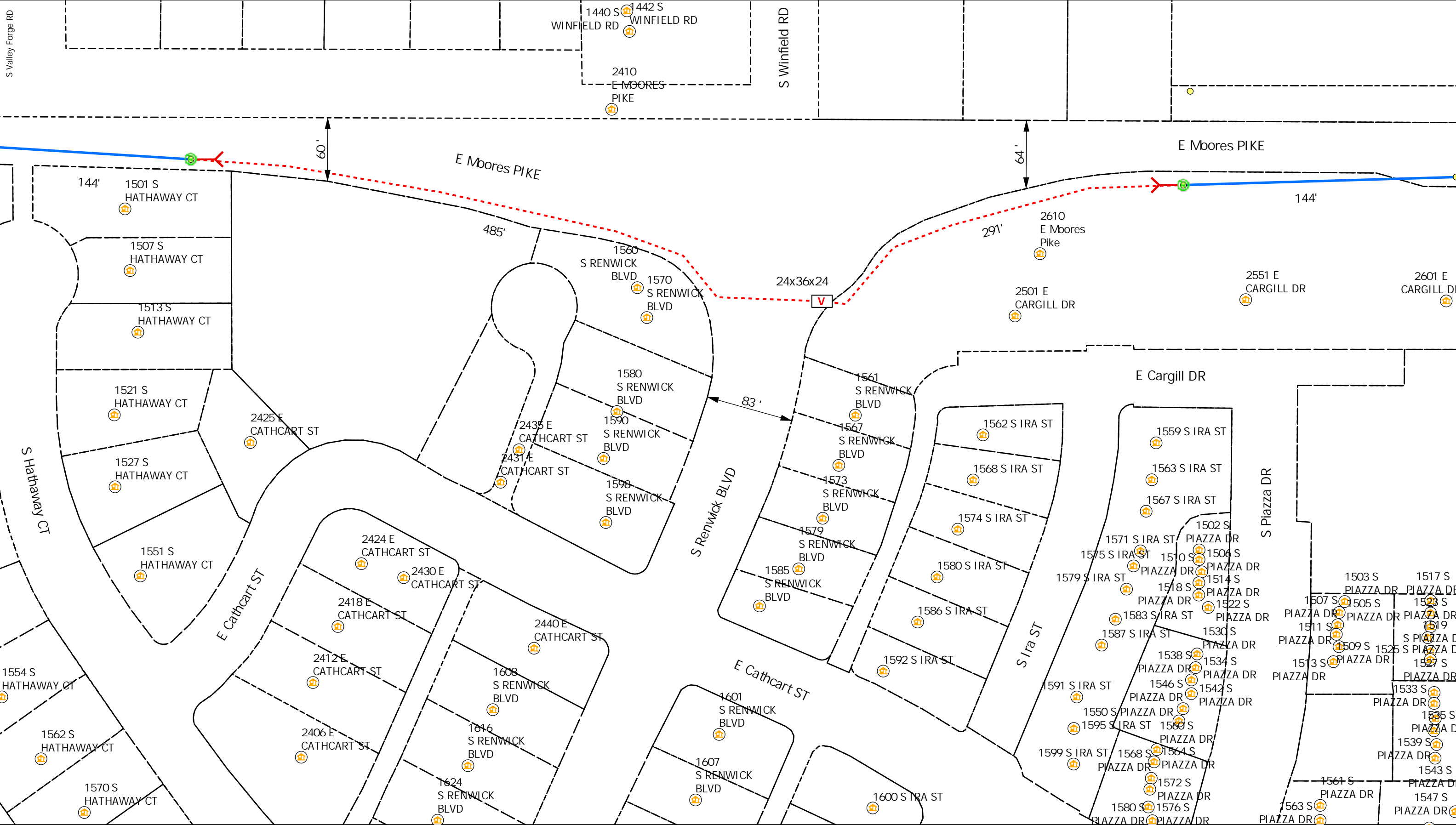

0 20 40 80 Feet

**Legend**

- Poles
- V Vaults
- Overhead Strand
- - - Conduit
- Bloomington\_Parcels
- Ⓡ Risers
- Ⓜ Address
- Y Anchor
- ← Sidewalk
- Grids

All Flowerpots 12" DIA

# 3

City of Bloomington, IN Permit:  
Design View

INI	BY	DATE	DESCRIPTION

Print 4 of 17

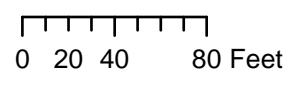
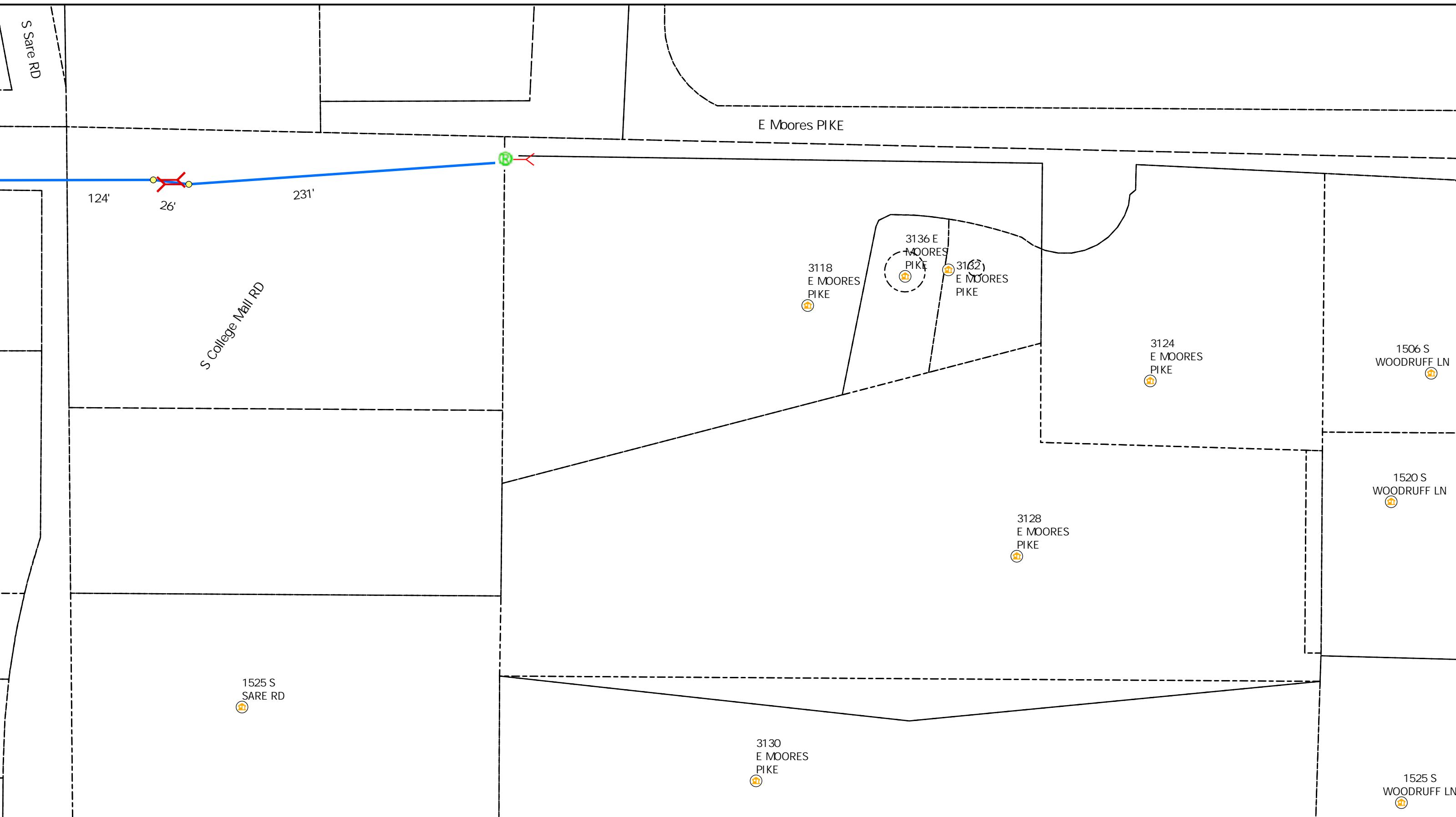

**Legend**

- Poles
- Vaults
- Overhead Strand
- Conduit
- Bloomington\_Parcels
- Risers
- Address
- Anchor
- Sidewalk
- Grids

All Flowerpots 12" DIA

**3**

City of Bloomington, IN Permit:  
Design View

INI	BY	DATE	DESCRIPTION





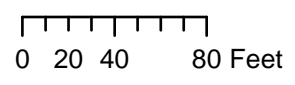
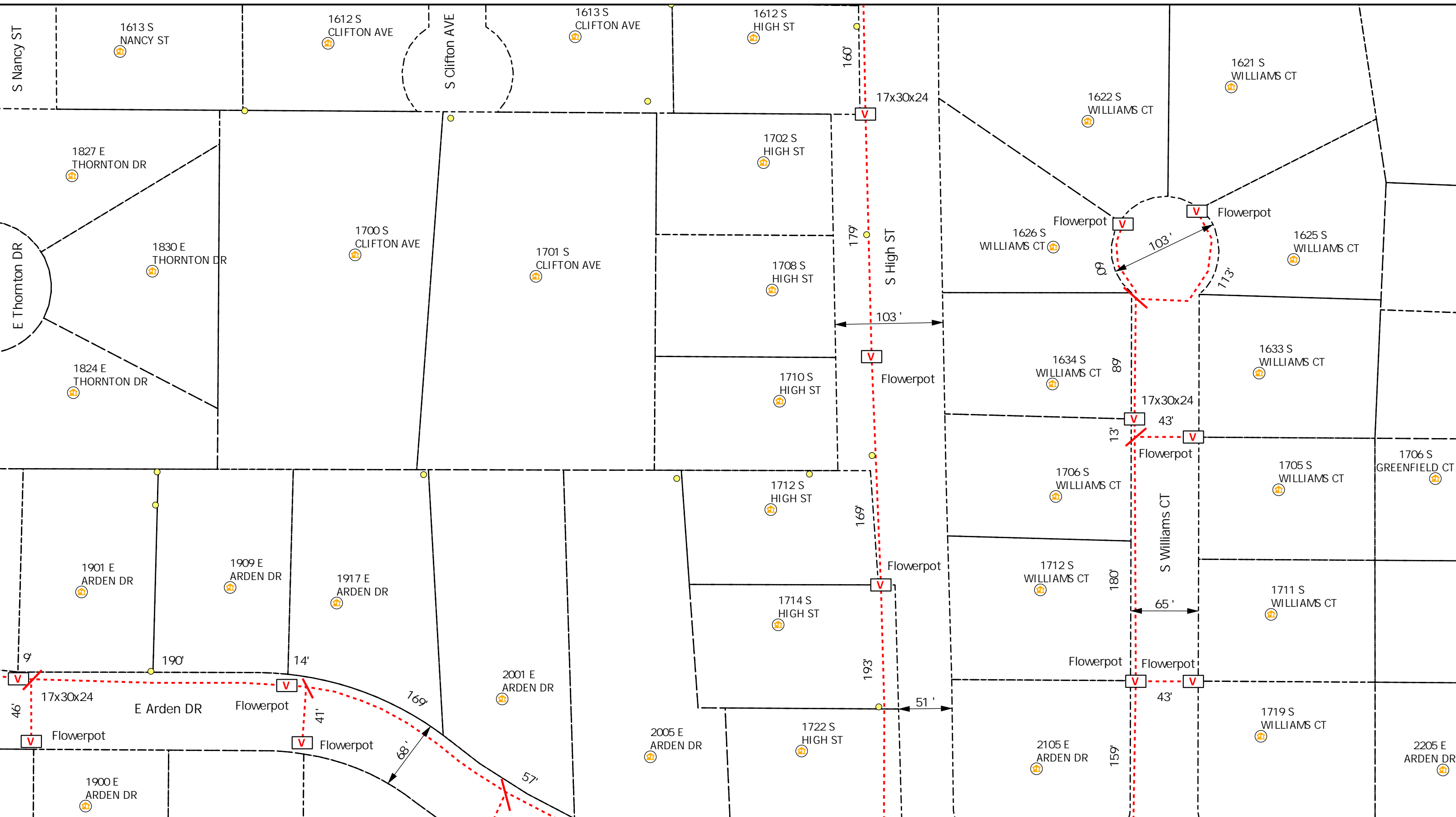

**Legend**

- Poles
- Vaults
- Overhead Strand
- Conduit
- Bloomington\_Parcels
- Risers
- Address
- Anchor
- Sidewalk
- Grids

All Flowerpots 12" DIA

# 3

City of Bloomington, IN Permit:  
Design View

INI	BY	DATE	DESCRIPTION





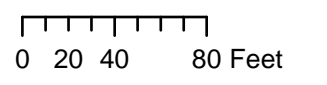
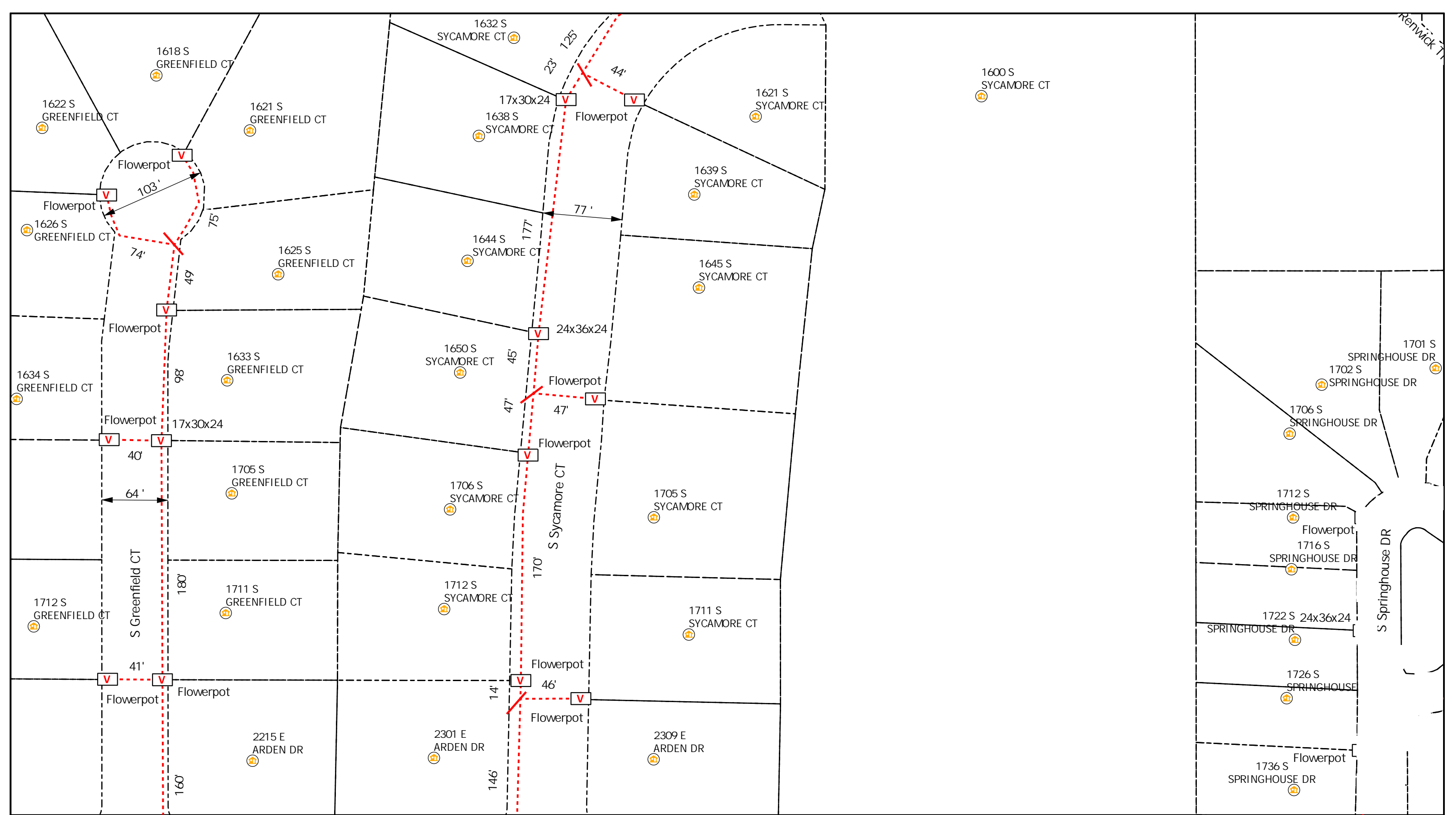

**Legend**

- Poles
- Vaults
- Overhead Strand
- Conduit
- Bloomington\_Parcels
- Risers
- Address
- Anchor
- Sidewalk
- Grids

All Flowerpots 12" DIA

# 3

City of Bloomington, IN Permit:  
Design View

INI	BY	DATE	DESCRIPTION



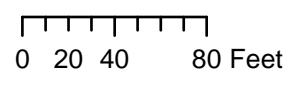
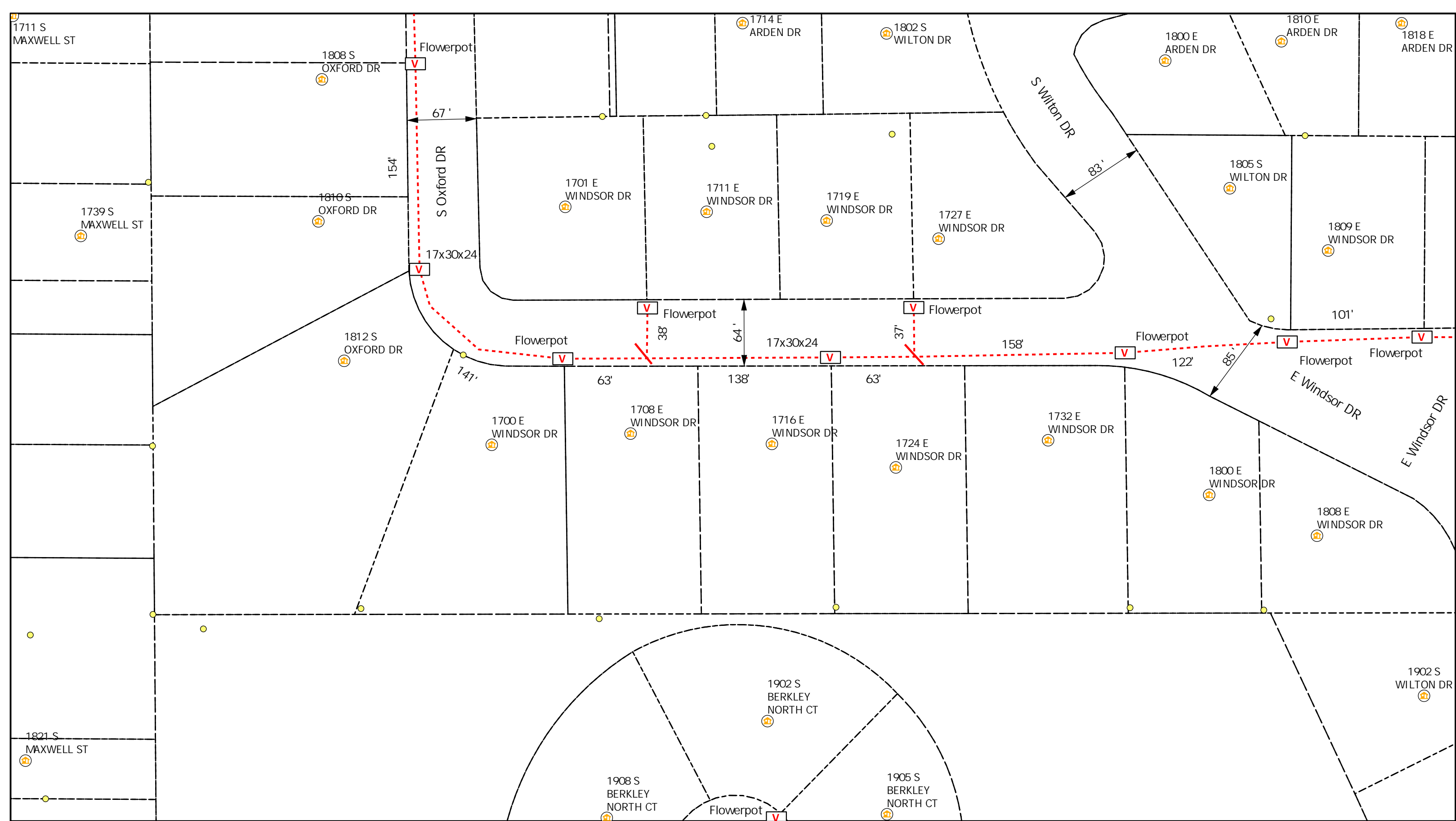

**Legend**

- Poles
- V Vaults
- Overhead Strand
- Conduit
- Bloomington\_Parcels
- R Risers
- A Address
- Y Anchor
- K Sidewalk
- Grids

All Flowerpots 12" DIA

3

City of Bloomington, IN Permit:  
Design View

INI	BY	DATE	DESCRIPTION



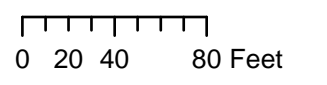
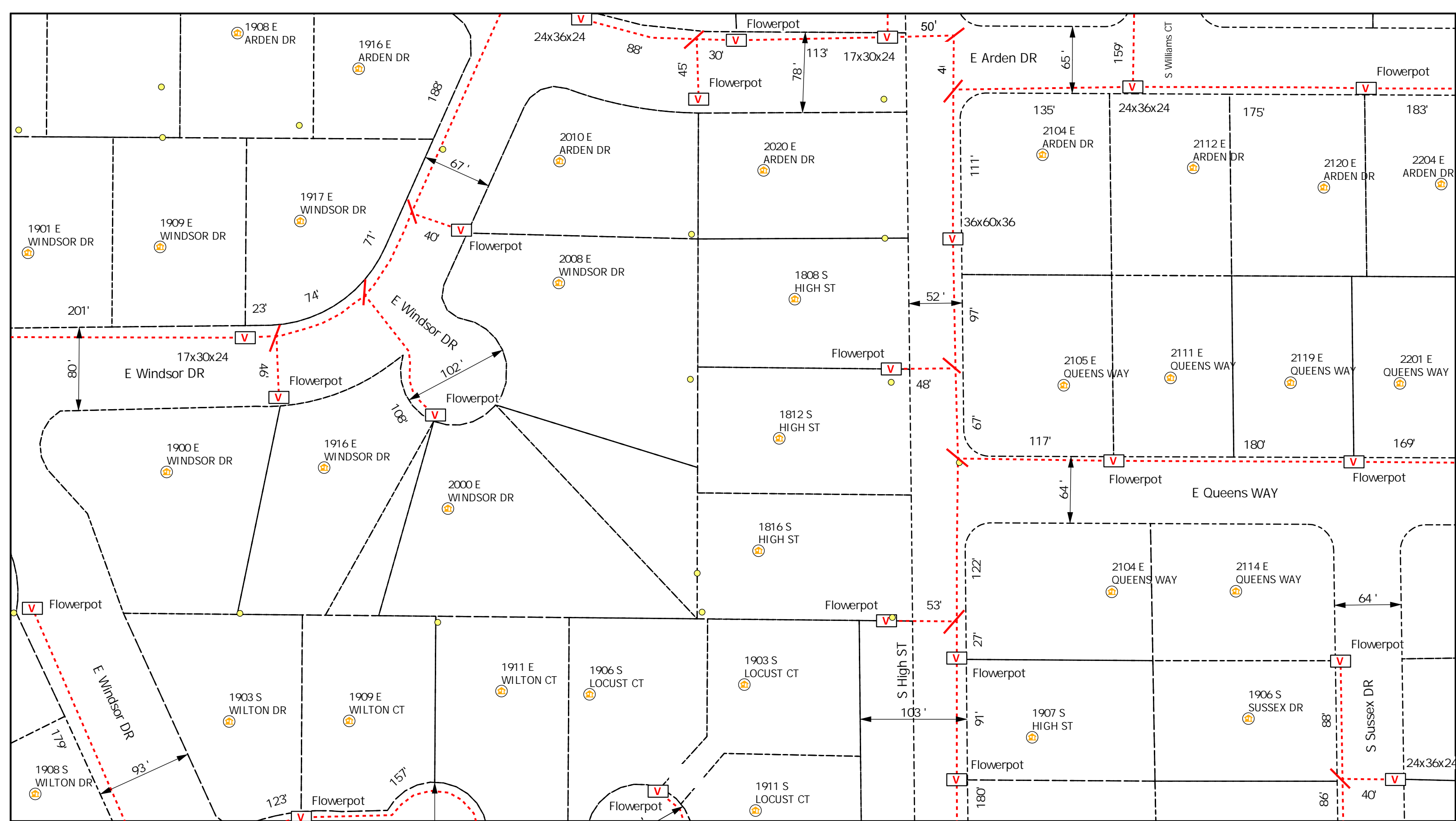

**Legend**

- Poles
- Vaults
- Overhead Strand
- Conduit
- Bloomington\_Parcels
- Risers
- Address
- Anchor
- Sidewalk
- Grids

All Flowerpots 12" DIA

# 3

City of Bloomington, IN Permit:  
Design View

INI	BY	DATE	DESCRIPTION



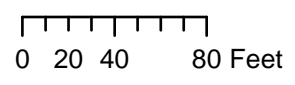
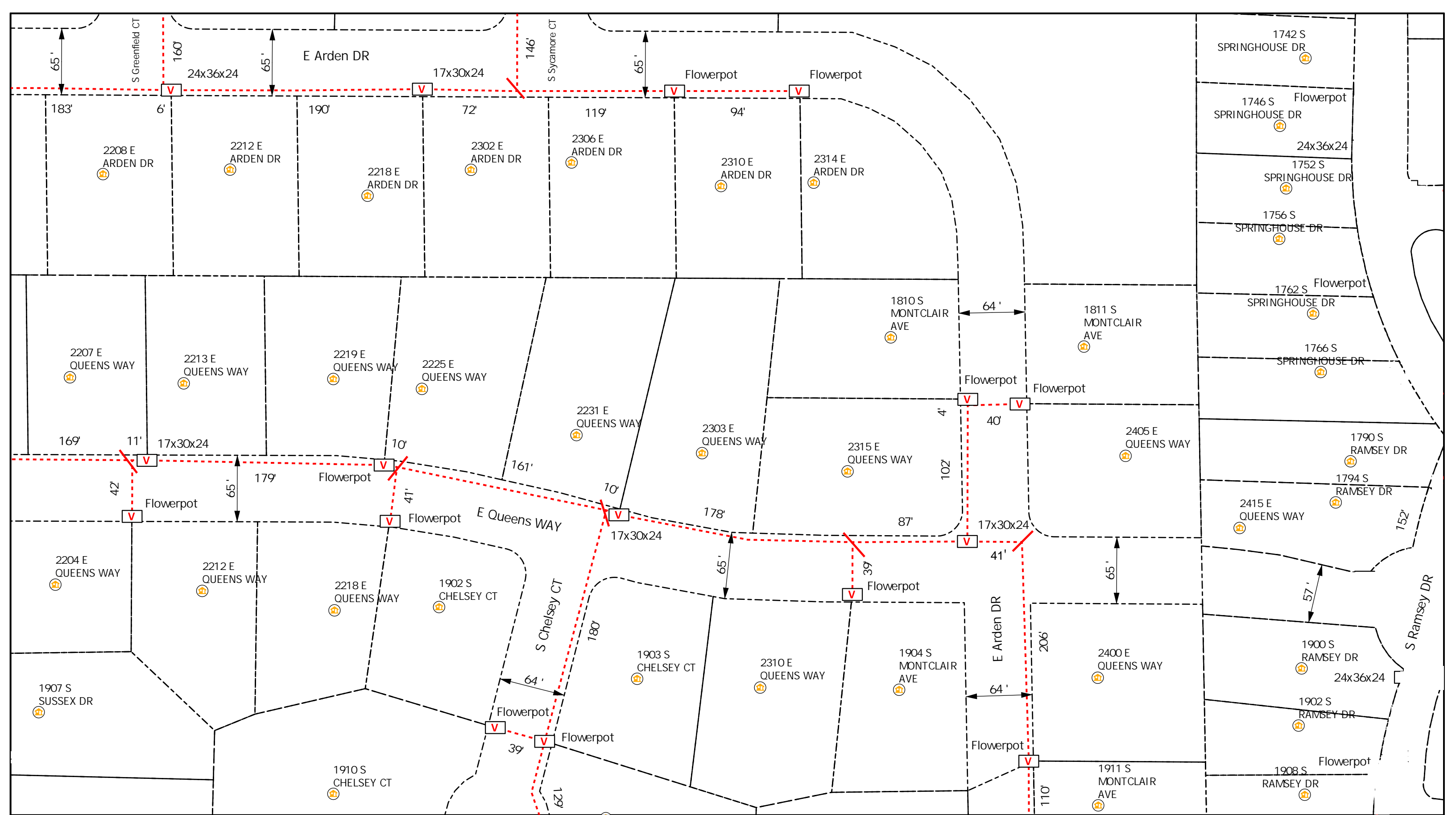

**Legend**

- Poles
- Vaults
- Overhead Strand
- Conduit
- Risers
- Address
- Grids
- Anchor
- Sidewalk

All Flowerpots 12" DIA

# 3

City of Bloomington, IN Permit:  
Design View

INI	BY	DATE	DESCRIPTION





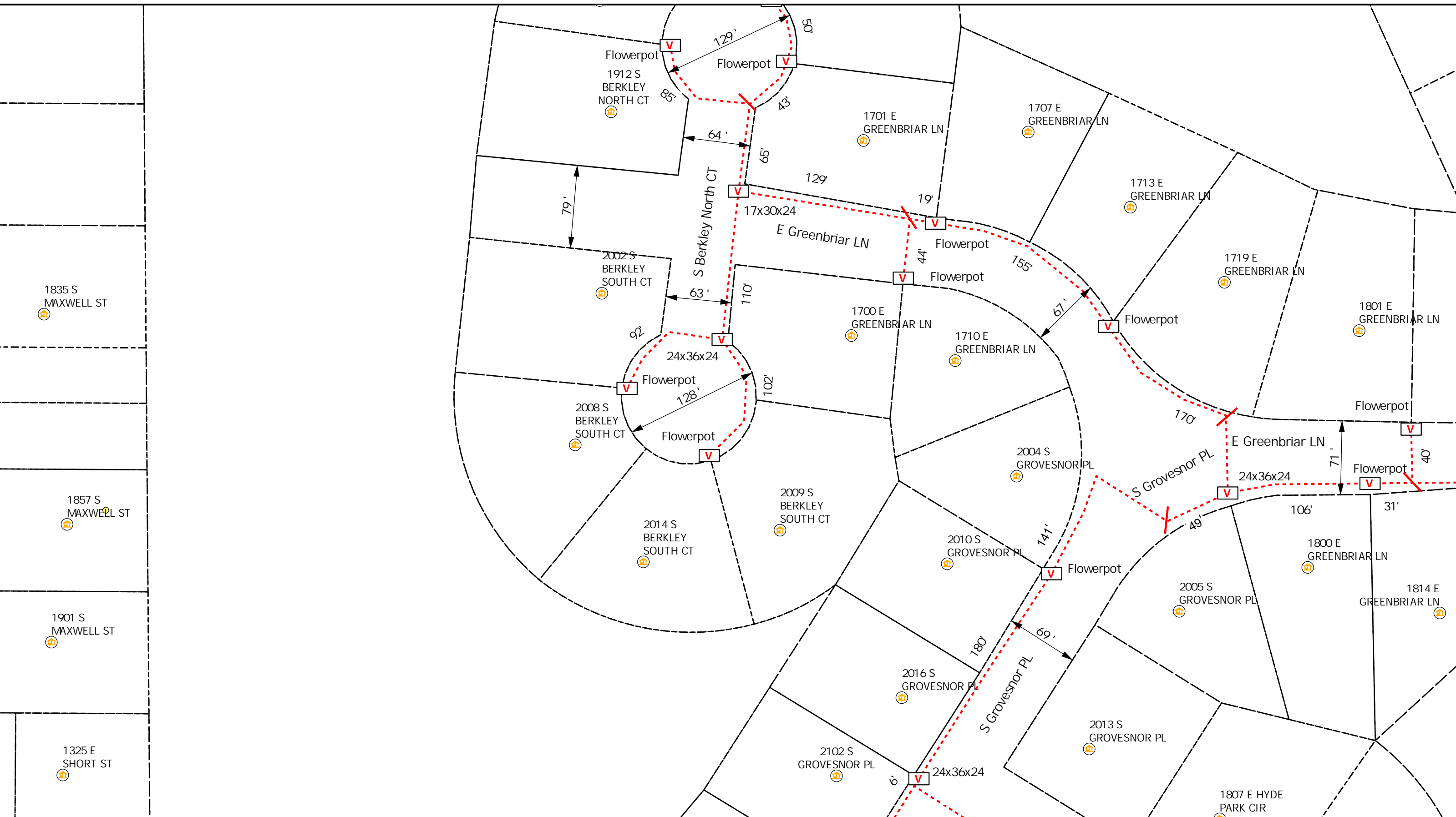

0 20 40 80 Feet

**Legend**

- Poles
- V Vaults
- Overhead Strand
- Conduit
- Bloomington\_Parcels
- R Risers
- A Address
- Y Anchor
- ← Sidewalk
- Grids

All Flowerpots 12" DIA

**3**

City of Bloomington, IN Permit:  
Design View

INI	BY	DATE	DESCRIPTION



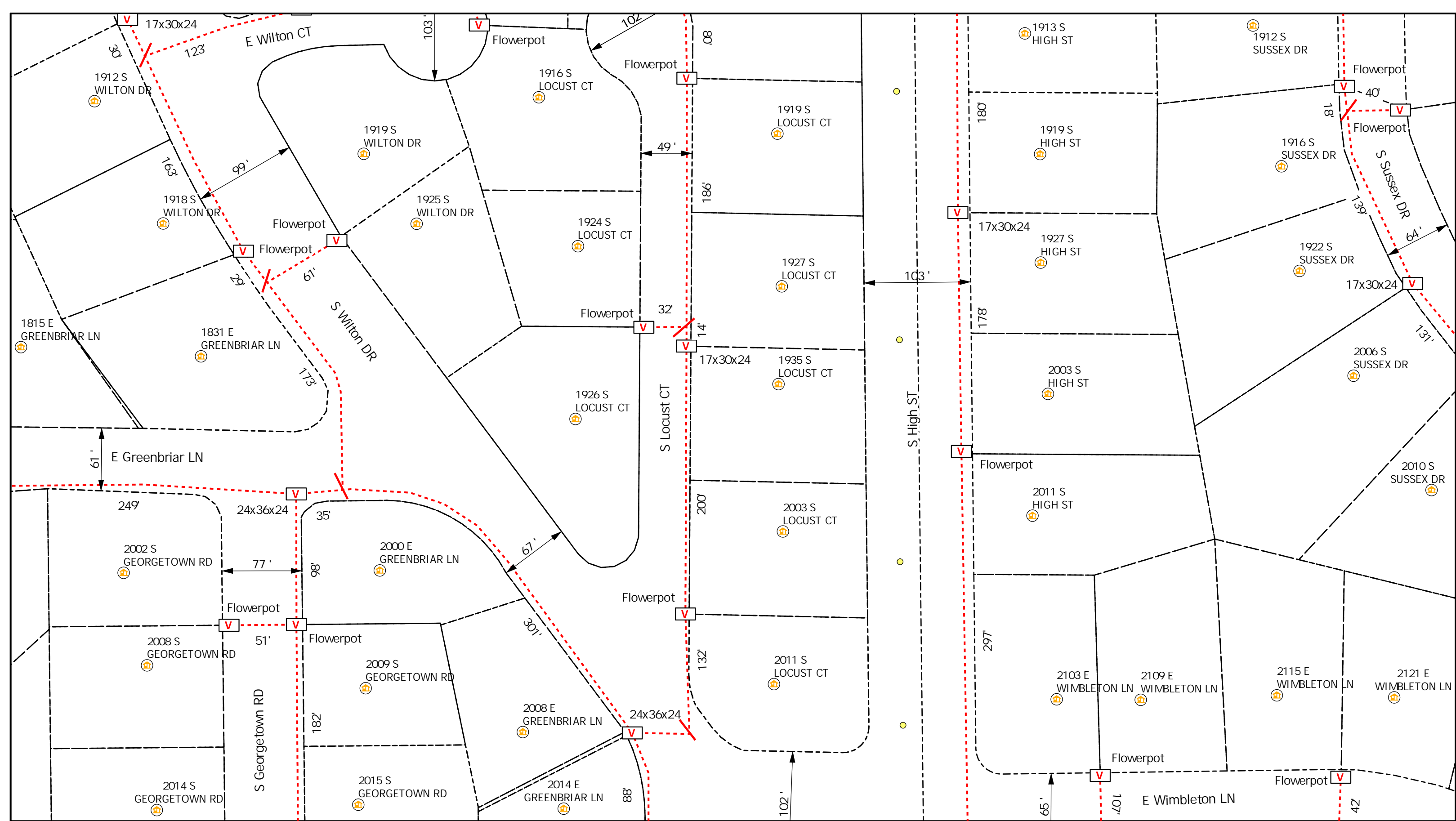

0 20 40 80 Feet

**Legend**

- Poles
- Vaults
- Overhead Strand
- Conduit
- Bloomington\_Parcels
- Risers
- Address
- Anchor
- Sidewalk
- Grids

All Flowerpots 12" DIA

**3**

City of Bloomington, IN Permit:  
Design View

INI	BY	DATE	DESCRIPTION



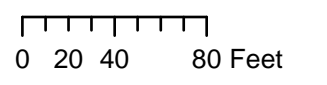
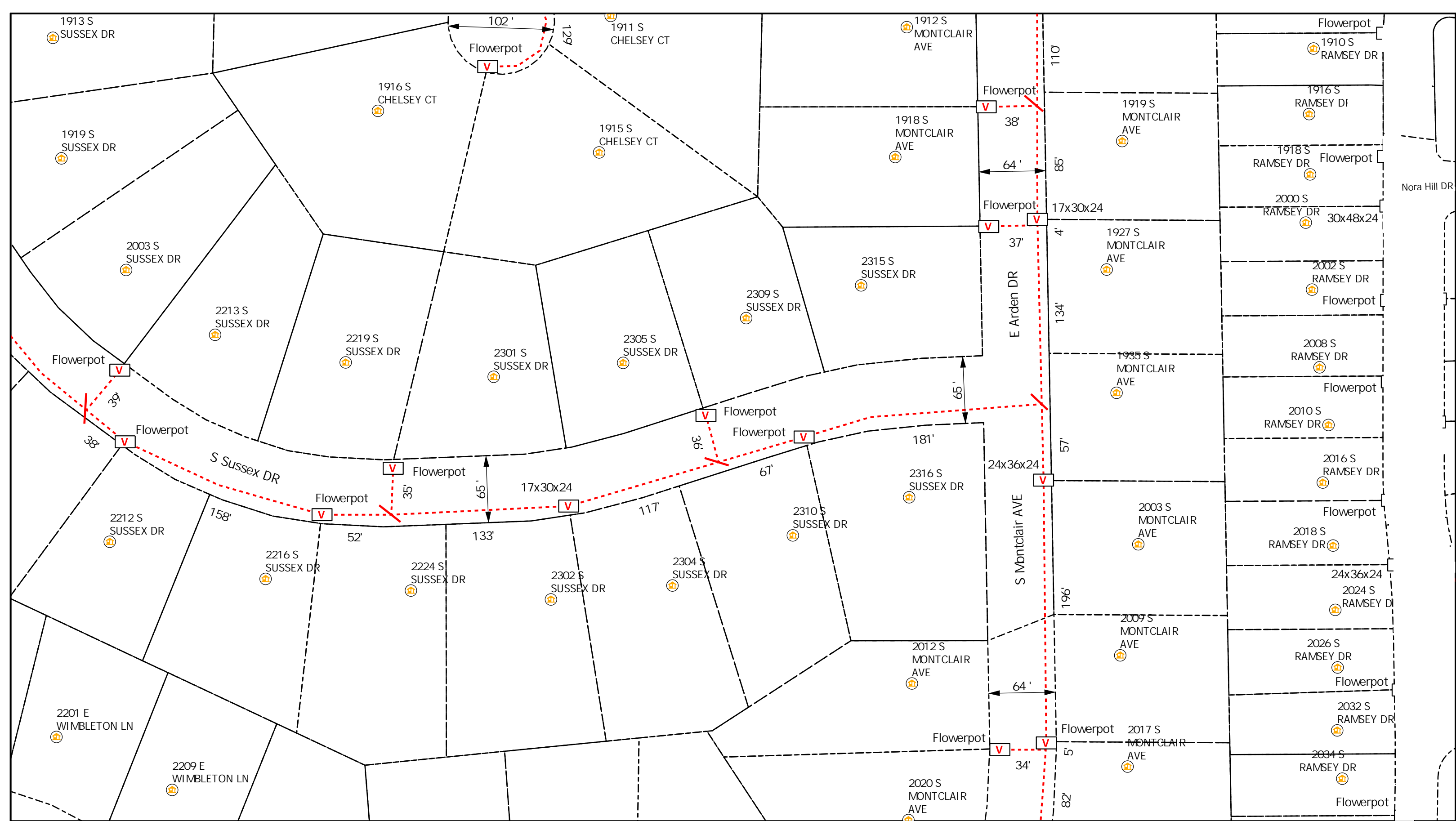

**Legend**

- Poles
- V Vaults
- Overhead Strand
- Conduit
- Bloomington\_Parcels
- R Risers
- 🏠 Address
- Y Anchor
- ← Sidewalk
- Grids

All Flowerpots 12" DIA

# 3

City of Bloomington, IN Permit:  
Design View

INI	BY	DATE	DESCRIPTION



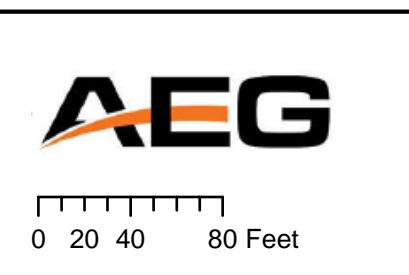
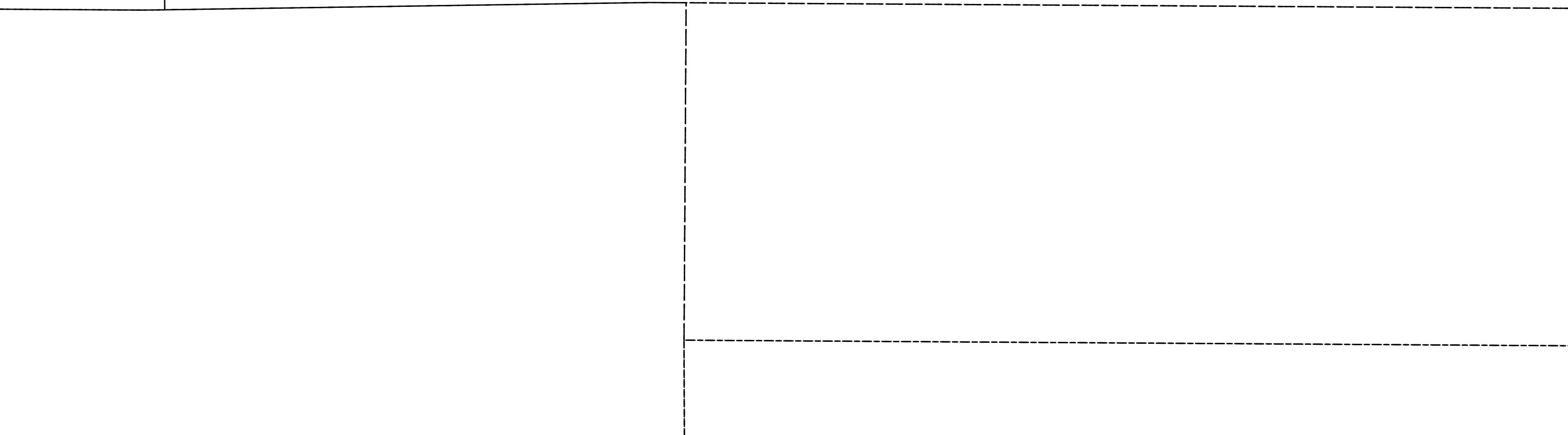
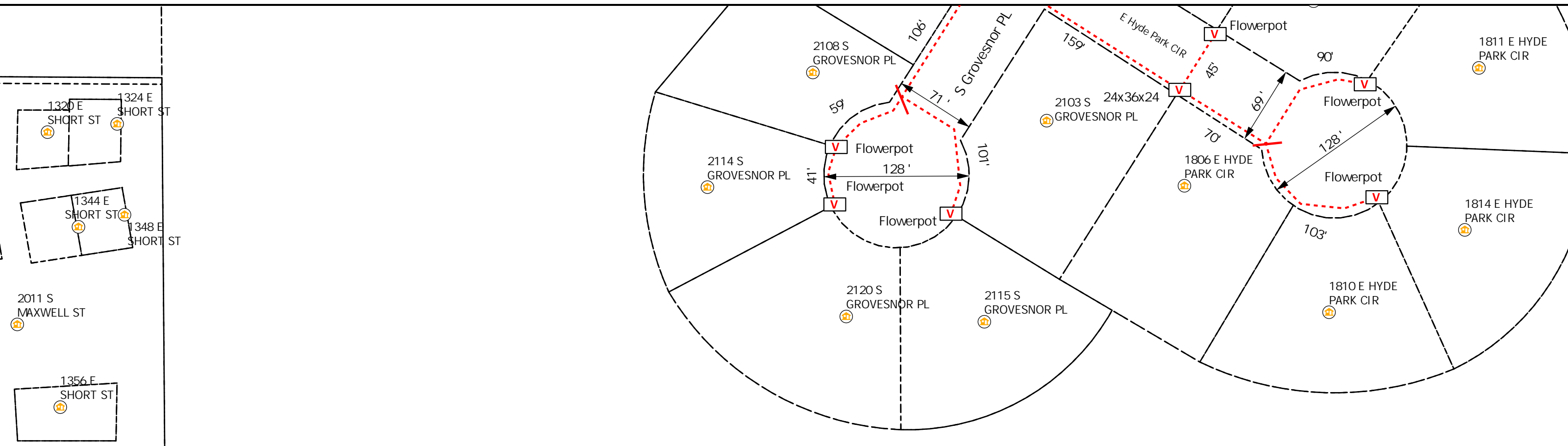

- Legend**
- Poles
  - V Vaults
  - Overhead Strand
  - Conduit
  - Bloomington\_Parcels
  - R Risers
  - H Address
  - Y Anchor
  - K Sidewalk
  - Grids

All Flowerpots 12" DIA

# 3

City of Bloomington, IN Permit:  
Design View

INI	BY	DATE	DESCRIPTION



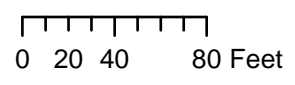
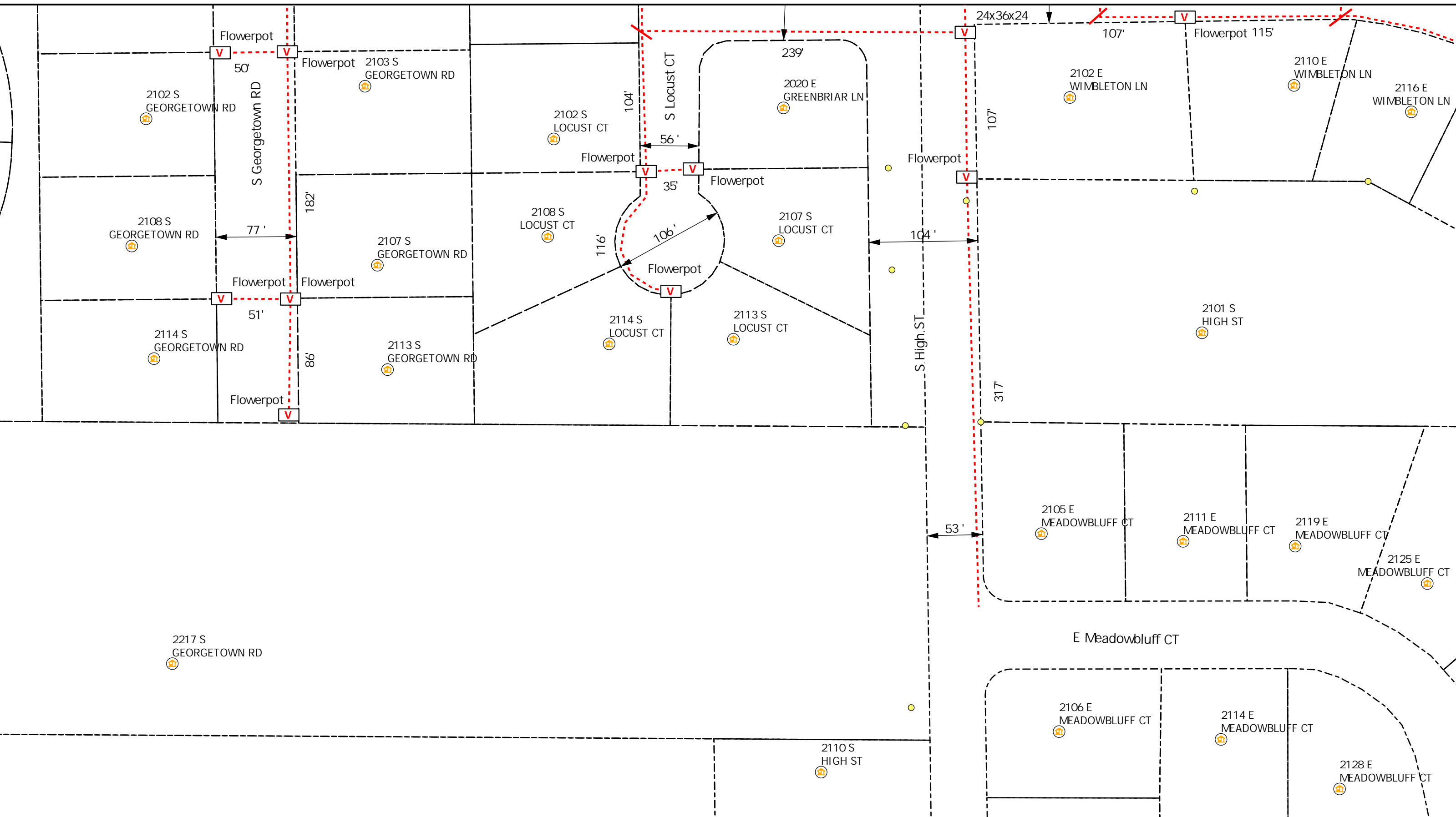

**Legend**

- Poles
- V Vaults
- Overhead Strand
- - - Conduit
- Bloomington\_Parcels
- R Risers
- A Address
- Y Anchor
- ← Sidewalk
- Grids

All Flowerpots 12" DIA

# 3

City of Bloomington, IN Permit:  
Design View

INI	BY	DATE	DESCRIPTION



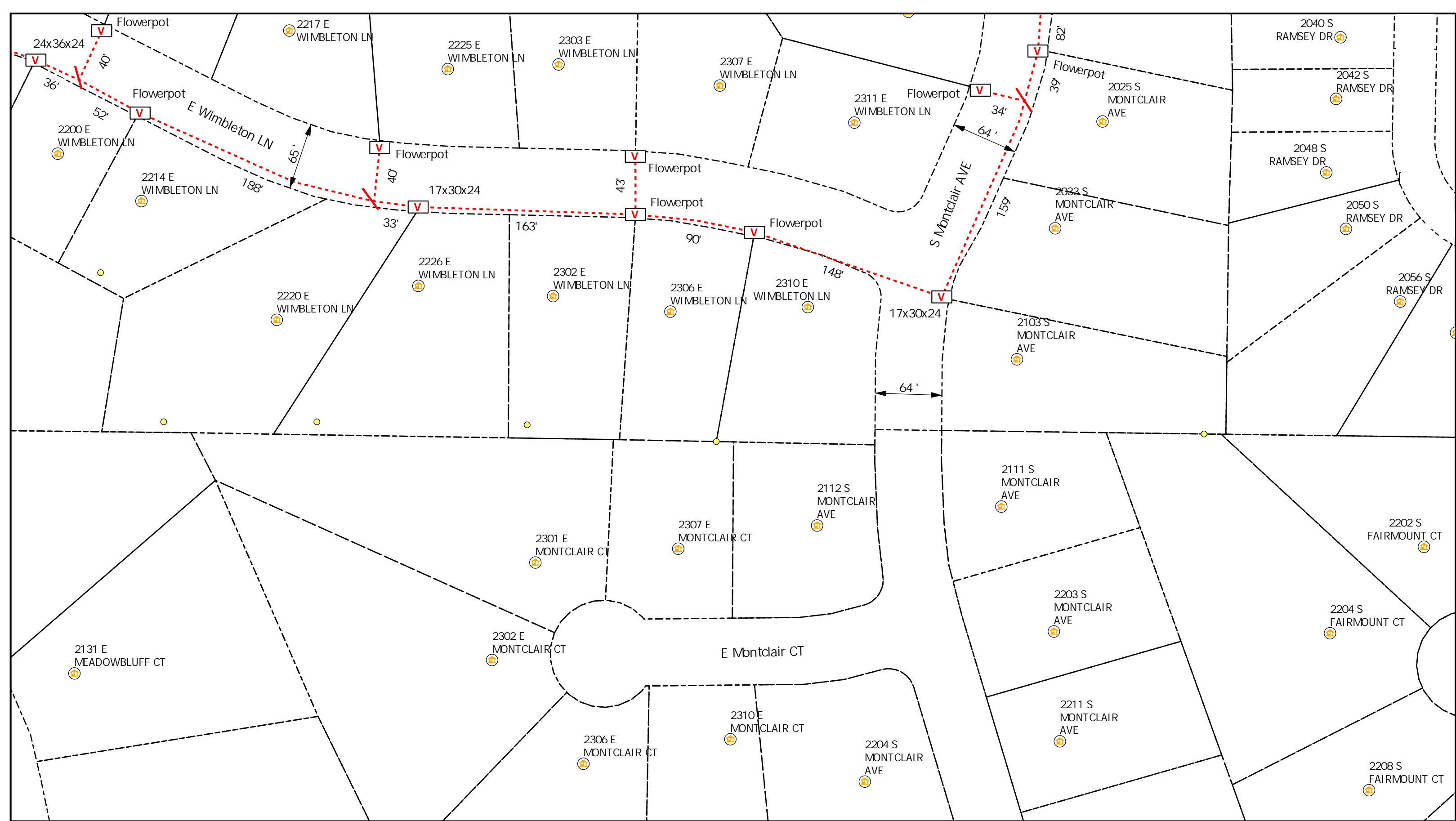

0 20 40 80 Feet

**Legend**

- Poles
- Vaults
- Overhead Strand
- Conduit
- Bloomington\_Parcels
- Risers
- Address
- Anchor
- Sidewalk
- Grids

All Flowerpots 12" DIA

**3**

City of Bloomington, IN Permit:  
Design View

INI	BY	DATE	DESCRIPTION



# Carlton® PV-Mold® Nonmetallic Pole Riser System

Carlton PV-Mold is a nonmetallic pole riser system designed to protect communications power cable installed on poles.

## Features:

- Meets or exceeds requirements outlined in the National Electric Safety Code (NESC).
- Designed in accordance with NEMA TC-19 specifications.
- Ultraviolet, cold temperature and corrosive atmosphere resistant.
- Schedule 40 wall meets Schedule 80 PVC conduit impact requirements per NEMA TC-19.
- No grounding required.
- Belled end fits over each added section or conduit.
- Flame retardant.
- Requires no maintenance.
- PV-Mold acts as an insulator against electrical shock.
- Interchangeable parts and accessories to match the needs of specific requirements.



Steel U-Guard requires grounding strapping and does not have belled ends.



PV-Mold has belled ends, flanged design and does not require grounding.

## Flanged Overall Length 10 Feet, Including Bell

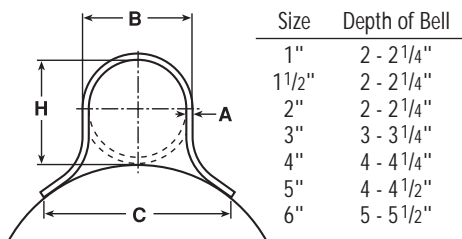

Slots are 1/2" from side to side, and allow for expansion and contraction.

Slot Dimensions: for sizes 2" through 6" are 5/16" wide, 3/4" long.

Slot Dimensions: for 1" and 1 1/2" are 3/16" wide, 3/4" long.

Slot Spacing: 18" from center, beginning 6" from end.

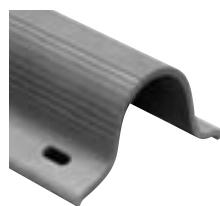

## Standard Duty

Part No.	Size	Std. Ctn. Qty.	Std. Ctn. Wt. (lbs.)	Dimensions				Actual Impact @ 0°C 20 Pound Top
				A	B	C	H	
59208N	1"	294	1059	0.100"	1 5/8"	2 3/8"	1 5/8"	40 Ft.-Lbs.
59211N	2"	136	726	0.100"	2 3/8"	4 1/2"	2 3/8"	100 Ft.-Lbs.
59211X (5' length)	2"	136	363	0.100"	2 3/8"	4 1/2"	2 3/8"	100 Ft.-Lbs.
59213N	3"	66	761	0.150"	3 1/2"	6"	3 1/2"	110 Ft.-Lbs.
59213X (5' length)	3"	66	381	0.150"	3 1/2"	6"	3 1/2"	100 Ft.-Lbs.
59215N	4"	65	910	0.150"	4 1/2"	6 1/2"	4 1/2"	110 Ft.-Lbs.
59216N	5"	30	515	0.150"	5 1/2"	7 1/2"	5 1/2"	110 Ft.-Lbs.

## Heavy Duty Schedule 40

59010N	1 1/2"	200	1142	0.145"	1 29/32"	3 1/2"	1 29/32"	100 Ft.-Lbs.
59011N	2"	136	1214	0.154"	2 3/8"	4 1/2"	2 3/8"	150 Ft.-Lbs.
59013N	3"	66	937	0.216"	3 1/2"	6"	3 9/32"	150 Ft.-Lbs.
59015N	4"	65	1621	0.237"	4 1/2"	6 1/2"	4 1/2"	260 Ft.-Lbs.
59015X (5' length)	4"	65	707	0.237"	4 1/2"	6 1/2"	4 1/2"	260 Ft.-Lbs.
59016N	5"	30	870	0.258"	5 1/2"	7 1/2"	5 1/2"	260 Ft.-Lbs.
59017N	6"	30	1160	0.280"	6 5/8"	8 3/4"	6 5/8"	260 Ft.-Lbs.

## Extra Heavy Duty Schedule 80

59411N	2"	136	1549	0.218"	2 3/8"	4 1/2"	2 3/8"	300 Ft.-Lbs.
59413N	3"	66	1495	0.030"	3 1/2"	6"	3 1/2"	525 Ft.-Lbs.

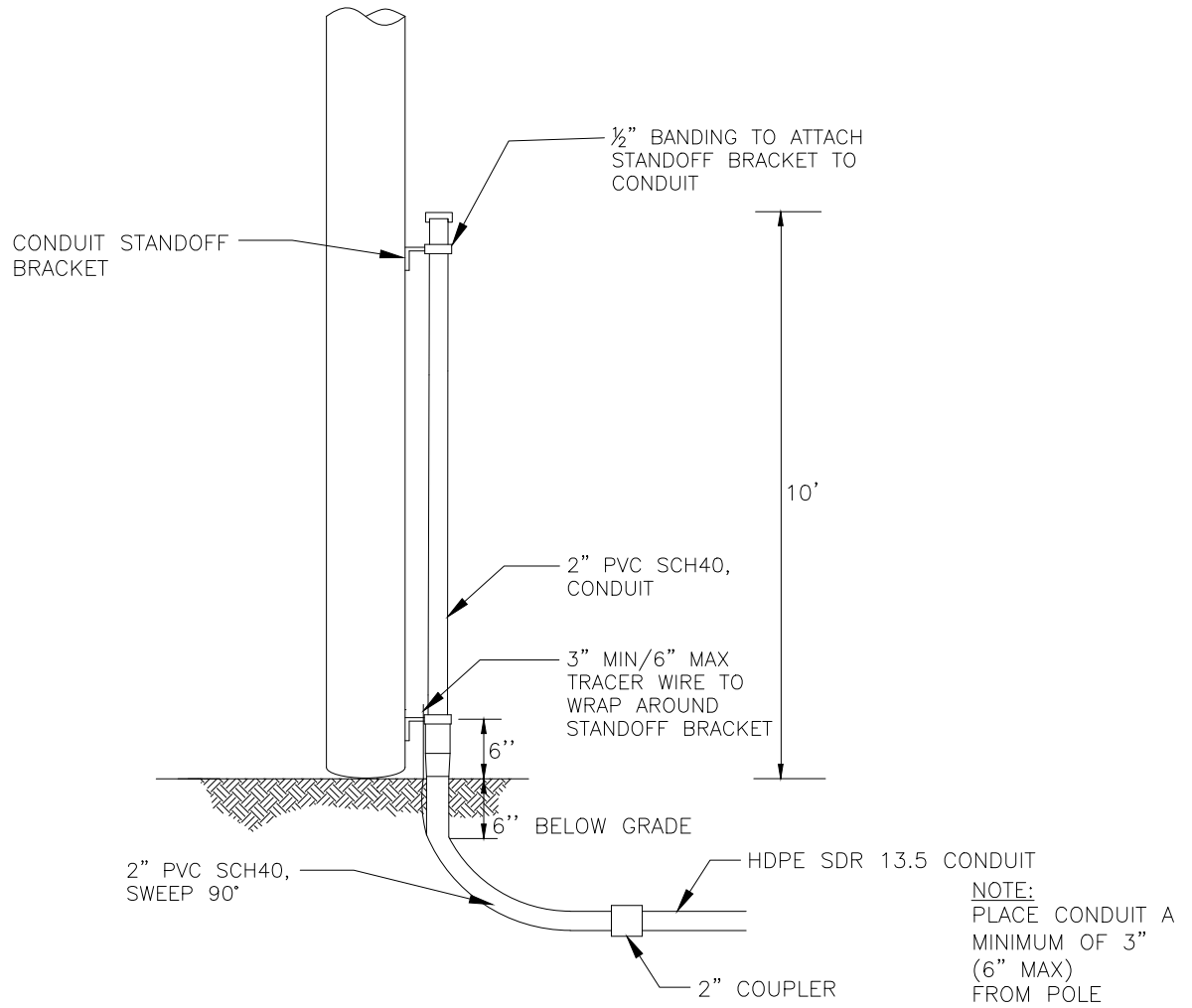

DESCRIPTION

QTY

MANUFACTURER  
(PREFERRED)

PART #

SCREW, LAG, 1/2" x 4-1/2"	10		
HDPE SDR 13.5 CONDUIT, VARIOUS SIZES	N/A		
2" PVC SCH40, RISER PIPE	1		
#12 TRACER WIRE	N/A		
2" PVC SCH40, SWEEP, 90 DEG	1		
CONDUIT STANDOFF BRACKET	VARIES		
CONDUIT STRAP KIT	VARIES		
2" COUPLER	1		



TYPICAL RISER  
CONDUIT  
WOOD POLE

(R2-W)



## CONCEPTUAL SIDE VIEW

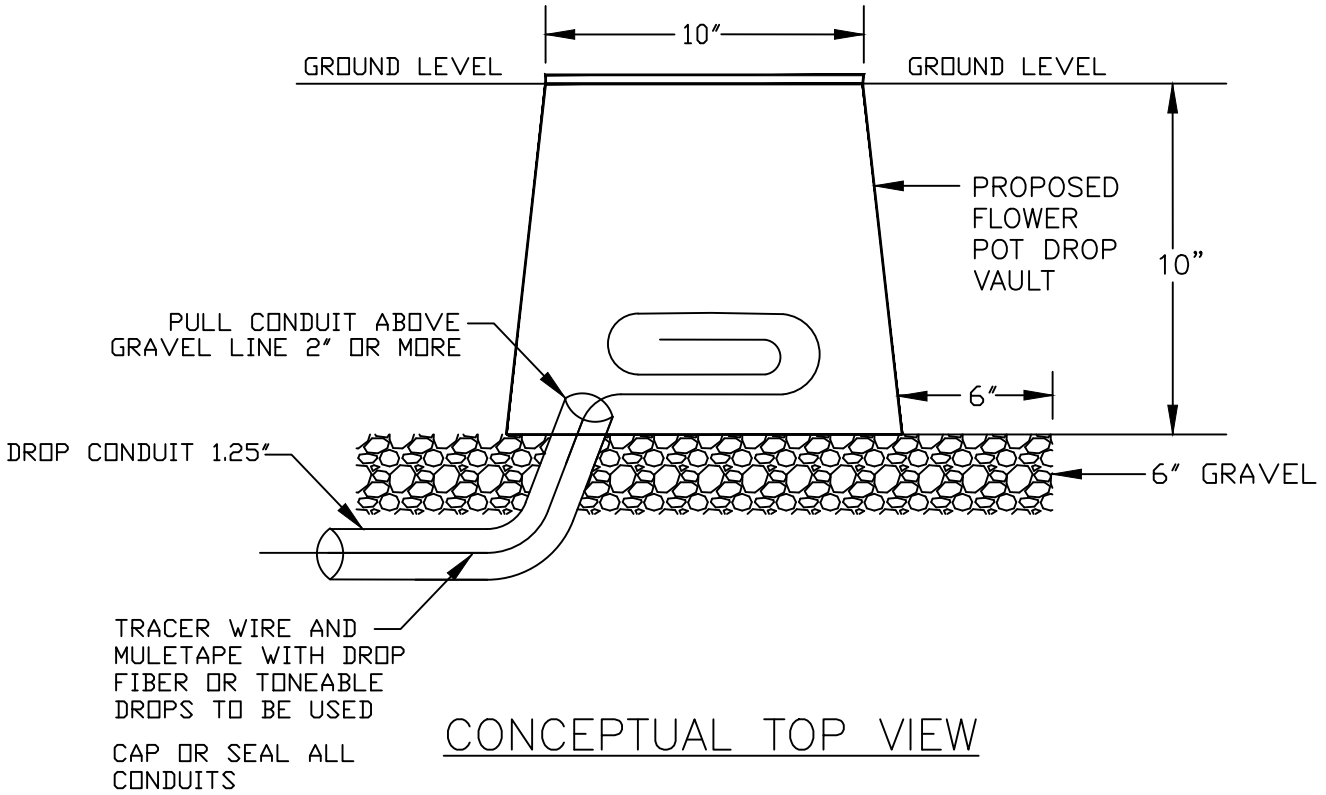

## CONCEPTUAL TOP VIEW

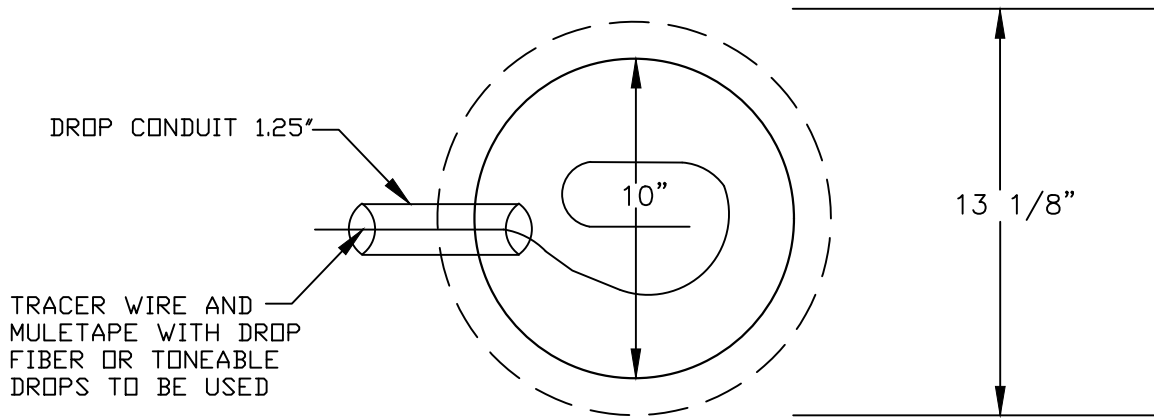

FLOWER POT

30"x48" PC UNIT, 2PC TIER 15/22  
 18", 24", and 36" HEIGHT



AMERICAN POLYMER COMPANY

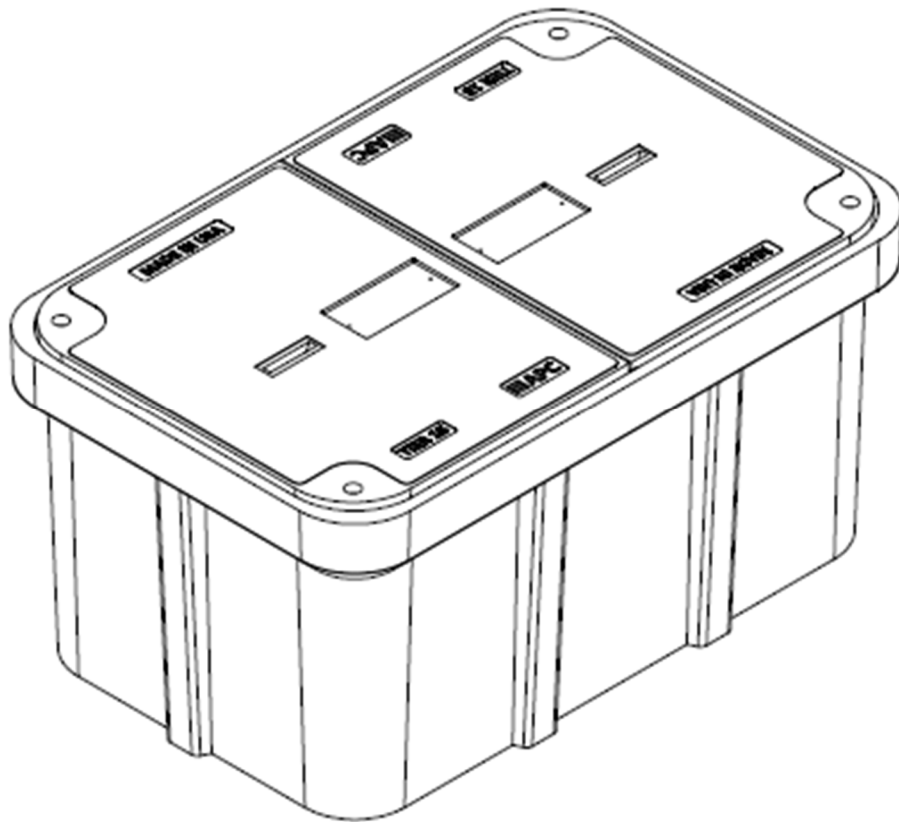

Description	Nominal Size	ANSI Tier	Part Number	Estimated Weight
PC Unit – TIER 15	30"x48"x18"	Tier 15	P304818HU15...	460 lbs.
PC Unit – TIER 22	30"x48"x18"	Tier 22	P304818HU22...	525 lbs.
PC Unit – TIER 15	30"x48"x24"	Tier 15	P304824HU15...	510 lbs.
PC Unit – TIER 22	30"x48"x24"	Tier 22	P304824HU22...	575 lbs.
PC Unit – TIER 15	30"x48"x36"	Tier 15	P304836HU15...	615 lbs.
PC Unit – TIER 22	30"x48"x36"	Tier 22	P304836HU22...	680 lbs.



# 30"x48" PC UNIT, 2PC TIER 15/22

18", 24", and 36" HEIGHT



AMERICAN POLYMER COMPANY

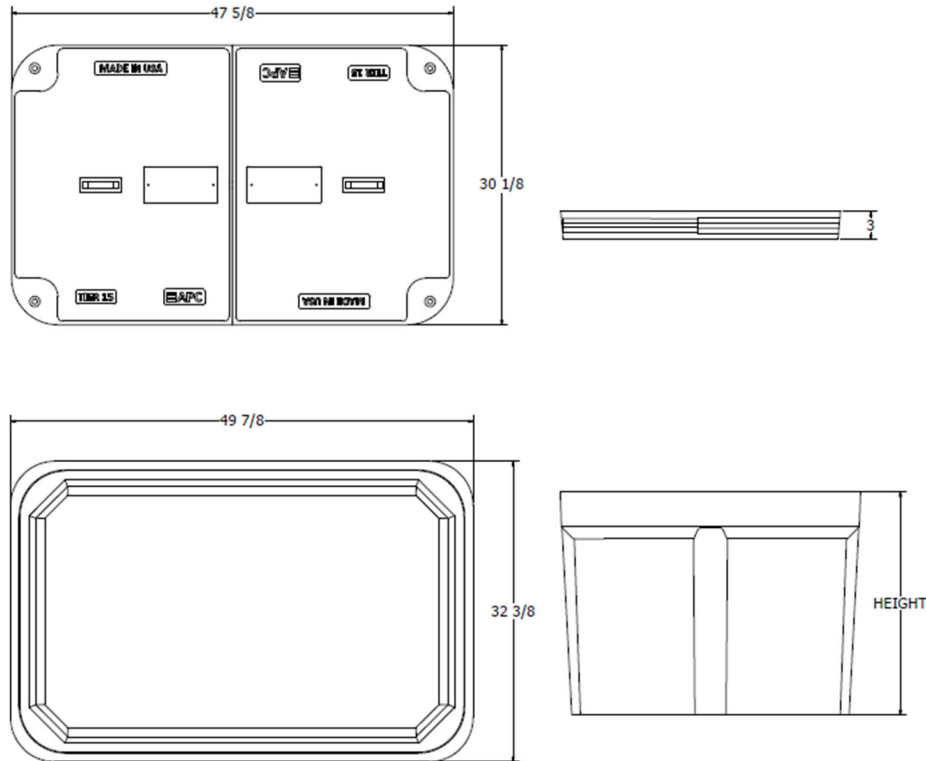

Components	Nominal Size	ANSI Tier	Part Number	Estimated Weight
Replacement Box	30"x48"x18"	Tier 22	P304818B22	185 lbs.
Replacement Box	30"x48"x24"	Tier 22	P304824B22	235 lbs.
Replacement Box	30"x48"x36"	Tier 22	P304836B22	340 lbs.
Replacement Lids - T15	30"x48" (half)	Tier 15	Various	150 lbs.
Replacement Lids - T22	30"x48" (half)	Tier 22	Various	170 lbs.

### Bolt options



Machine Thread



Auger Thread



24"x36" PC UNIT, TIER 15/22  
 18", 24", 30", and 36" HEIGHT



AMERICAN POLYMER COMPANY

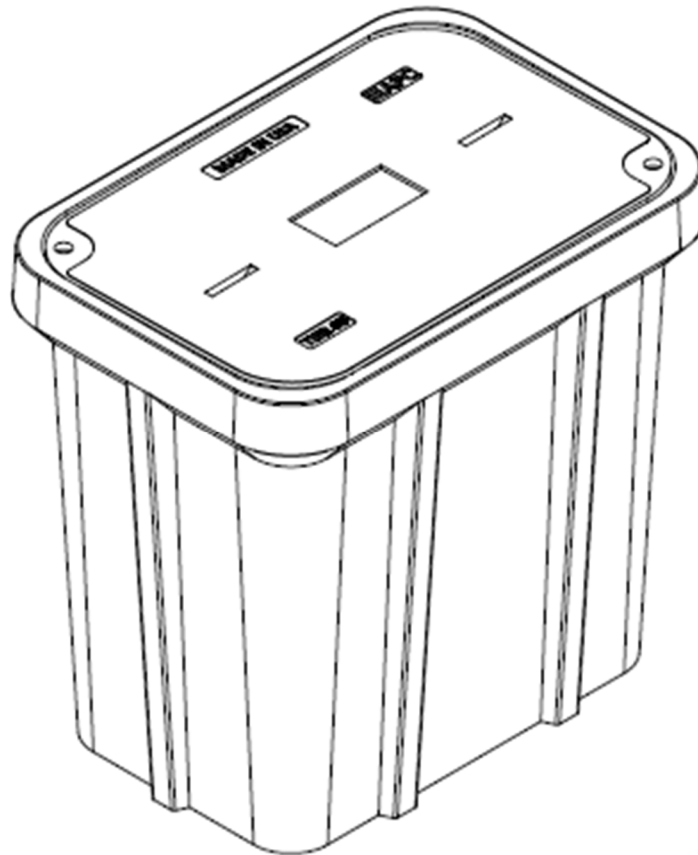

Description	Nominal Size	ANSI Tier	Part Number	Estimated Weight
PC Unit – TIER 15	24x36"x18"	Tier 15	P243618U15...	335 lbs.
PC Unit – TIER 22	24x36"x18"	Tier 22	P243618U22...	355 lbs.
PC Unit – TIER 15	24x36"x24"	Tier 15	P243624U15...	365 lbs.
PC Unit – TIER 22	24x36"x24"	Tier 22	P243624U22...	385 lbs.
PC Unit – TIER 15	24x36"x30"	Tier 15	P243630U15...	395 lbs.
PC Unit – TIER 22	24x36"x30"	Tier 22	P243630U22...	415 lbs.
PC Unit – TIER 15	24x36"x36"	Tier 15	P243636U15...	425 lbs.
PC Unit – TIER 22	24x36"x36"	Tier 22	P243636U22...	445 lbs.





# 24"x36" PC UNIT, TIER 15/22

18", 24", 30", and 36" HEIGHT



AMERICAN POLYMER COMPANY

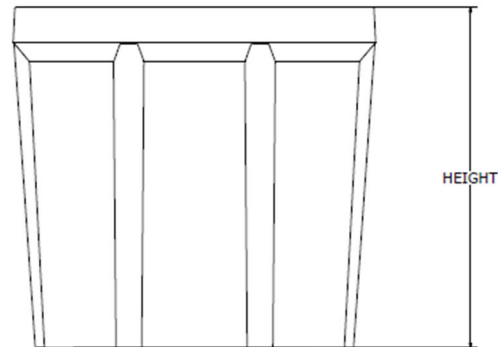
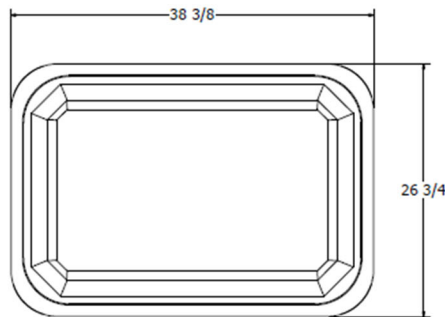
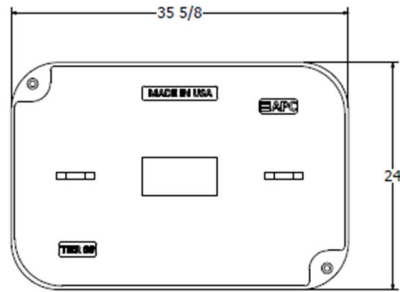

Components	Nominal Size	ANSI Tier	Part Number	Estimated Weight
Replacement Box	24"x36"x18"	Tier 22	P243618B22	165 lbs.
Replacement Box	24"x36"x24"	Tier 22	P243624B22	195 lbs.
Replacement Box	24"x36"x30"	Tier 22	P243630B22	225 lbs.
Replacement Box	24"x36"x36"	Tier 22	P243636B22	255 lbs.
Replacement Lids - T15	24"x36"	Tier 15	Various	170 lbs.
Replacement Lids - T22	24"x36"	Tier 22	Various	190 lbs.

### Bolt options

Hex Head



Machine Thread



Penta Head



Auger Thread



17"x30" PC UNIT, TIER 15/22

12", 18", 24", and 30" HEIGHT



AMERICAN POLYMER COMPANY

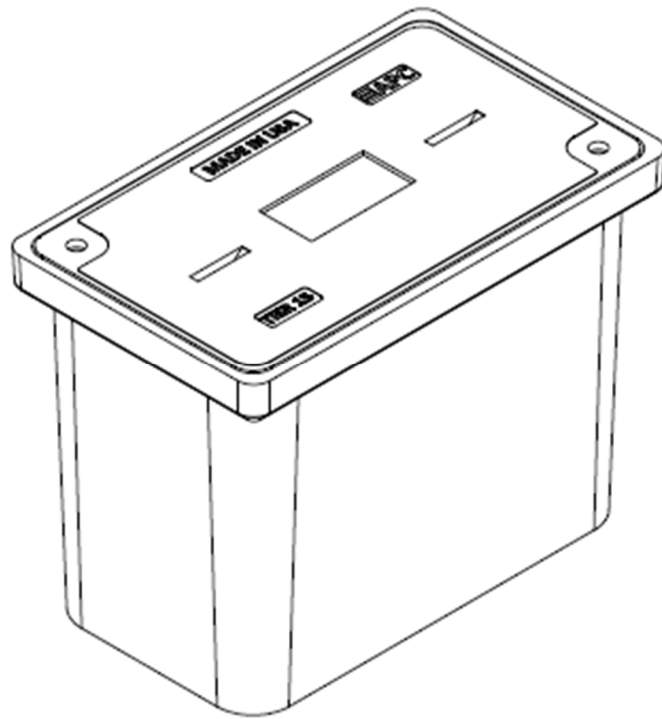

Description	Nominal Size	ANSI Tier	Part Number	Estimated Weight
PC Unit – TIER 15	17"x30"x12"	Tier 15	P173012U15...	138 lbs.
PC Unit – TIER 22	17"x30"x12"	Tier 22	P173012U22...	147 lbs.
PC Unit – TIER 15	17"x30"x18"	Tier 15	P173018U15...	172 lbs.
PC Unit – TIER 22	17"x30"x18"	Tier 22	P173018U22...	181 lbs.
PC Unit – TIER 15	17"x30"x24"	Tier 15	P173024U15...	192 lbs.
PC Unit – TIER 22	17"x30"x24"	Tier 22	P173024U22...	201 lbs.
PC Unit – TIER 15	17"x30"x30"	Tier 15	P173030U15...	217 lbs.
PC Unit – TIER 22	17"x30"x30"	Tier 22	P173030U22...	226 lbs.



# 17"x30" PC UNIT, TIER 15/22

12", 18", 24", and 30" HEIGHT



AMERICAN POLYMER COMPANY

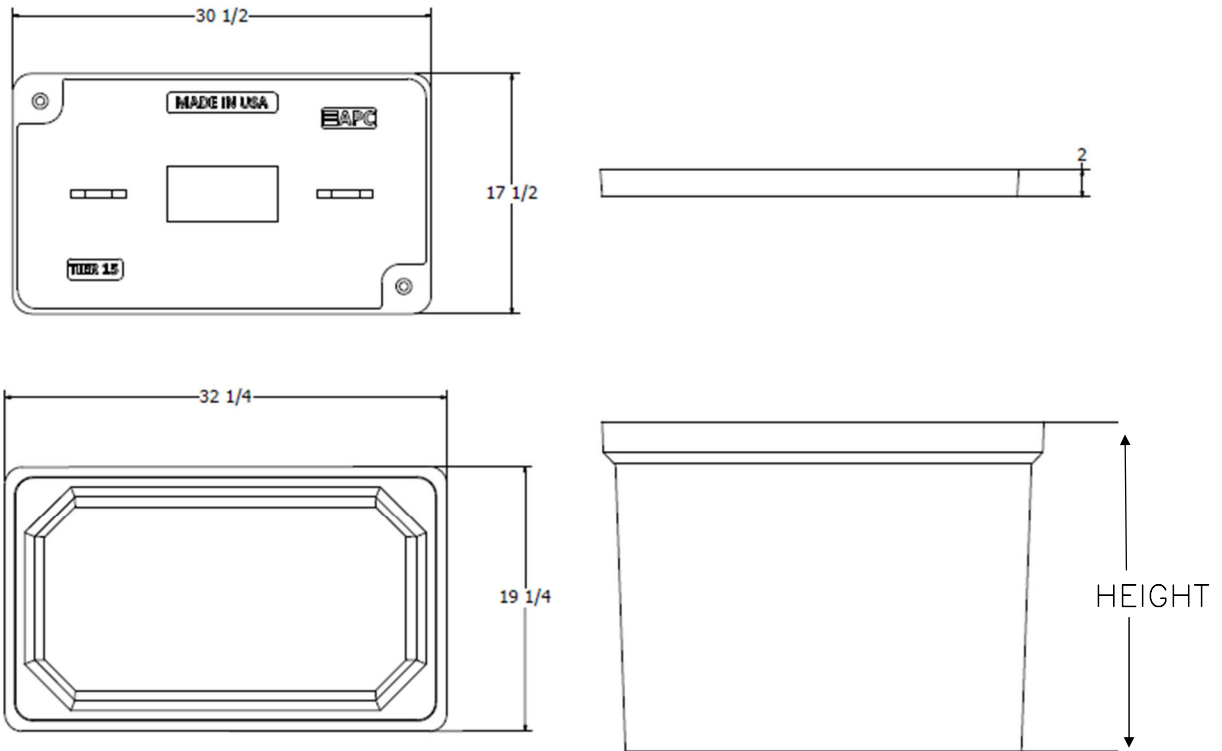

Components	Nominal Size	ANSI Tier	Part Number	Estimated Weight
Replacement Box	17"x30"X12"	Tier 22	P173012B22	66 lbs.
Replacement Box	17"x30"X18"	Tier 22	P173018B22	100 lbs.
Replacement Box	17"x30"X24"	Tier 22	P173024B22	120 lbs.
Replacement Box	17"x30"X30"	Tier 22	P173030B22	145 lbs.
Replacement Lids – T15	17"x30"	Tier 15	Various	72 lbs.
Replacement Lids – T22	17"x30"	Tier 22	Various	81 lbs.

### Bolt options



Machine Thread



Auger Thread



33"x60" PC UNIT, 2PC TIER 15/22  
36" HEIGHT



AMERICAN POLYMER COMPANY

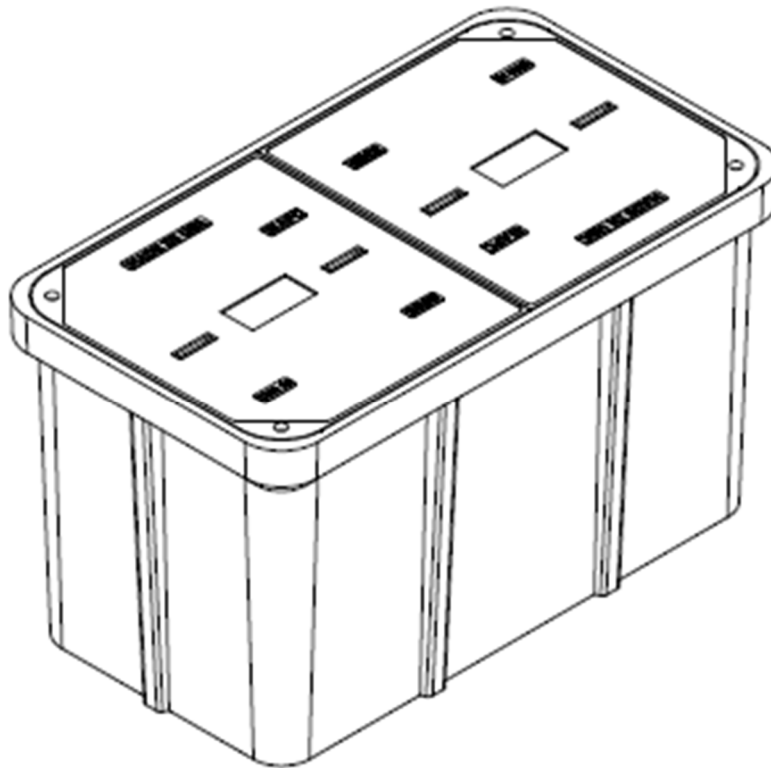

Description	Nominal Size	ANSI Tier	Part Number	Estimated Weight
PC Unit - TIER 15	33"x60"x36"	Tier 15	P336036U15...	930 lbs.
PC Unit - TIER 22	33"x60"x36"	Tier 22	P336036U22...	1030 lbs.





# 33"x60" PC UNIT, 2PC TIER 15/22

## 36" HEIGHT



AMERICAN POLYMER COMPANY

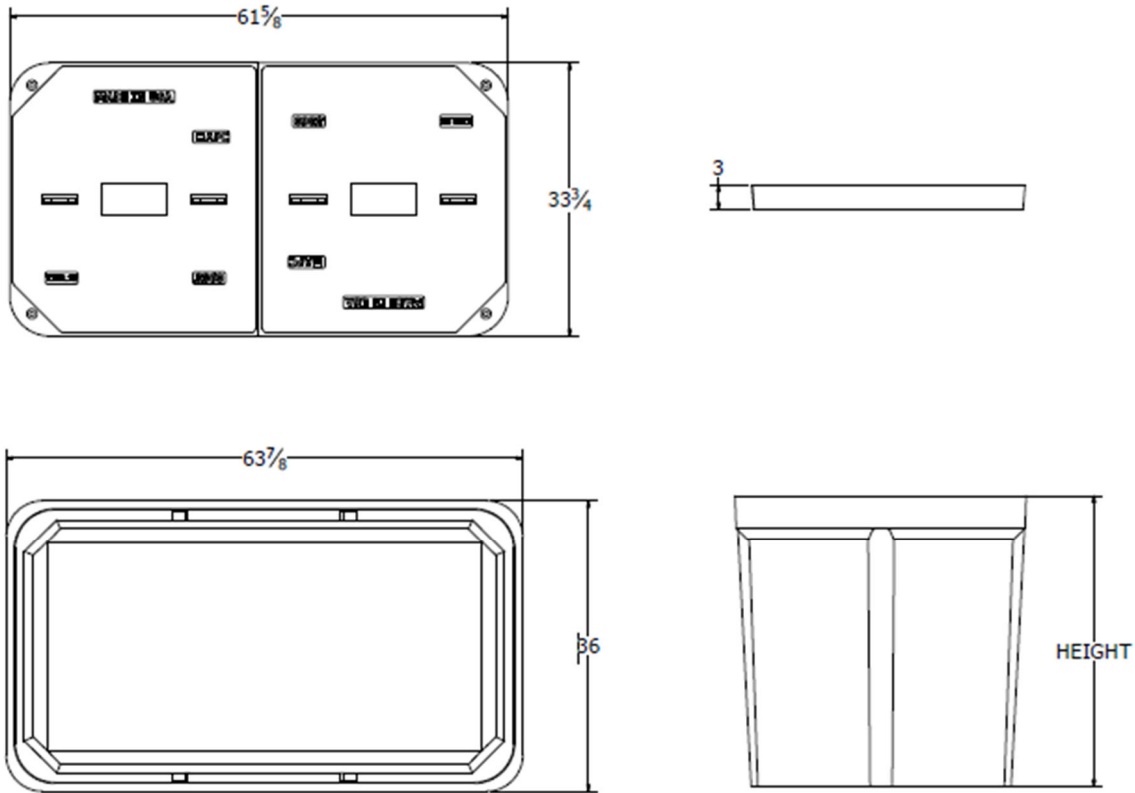

Components	Nominal Size	ANSI Tier	Part Number	Estimated Weight
Replacement Box	33"x60"x36"	Tier 22	P336036B22	530 lbs.
Replacement Lids - T15	33"x60" (half)	Tier 15	Various	200 lbs.
Replacement Lids - T22	33"x60" (half)	Tier 22	Various	250 lbs.

### Bolt options

Hex Head



Machine Thread



Penta Head



Auger Thread









Spacing Charts Based on MUTCD		Must be Approved by an Engineer					
Speed (MPH) Prior To Road Work	SIGN SPACING, FT.		BUFFER SPACE, FT.	TAPER LENGTH, FT.		CHANNELIZING SPACING, FT.	
	Non-Divided Highways	Divided Highways	Length	Shoulder (10 ft Width)	Lane (12 ft Width)	Through Taper	Through Buffer/Work Area
0-35	200	200	250	70	245	35	50
40-45	350	500	360	150	540	40	80
50-55	500	1000	495	185	660	50	100
60-70	SA-1000, SB-1500, SC-2640 Urban Low Speed - 100 FT		730	235	840	60	120

APPROVED/ACCEPTED BY:  
ENGINEER, OWNER, or PRIME CONTRACTOR  
 Check for Notice to Proceed.  
BLC02a-F13\_E Queens Way -TCP2

Signature: \_\_\_\_\_

Company: \_\_\_\_\_

**Date:** 1/17/2023 **Project:** BLC02a-F13\_E Queens Way -TCP2 :  
: **Traffic Control Suggestion For:** AEG :  
**By:** Road Runner Safety Services, Inc. : Nathan

**Comments:**  
Drawing not to scale. Traffic control plan must be approved by an engineer. This is a suggestion only. Road Runners Safety Services, Inc. has no liability for this suggested traffic control plan. Actual placement and spacing of all traffic control devices will depend on field conditions and must conform to MUTCD standards.

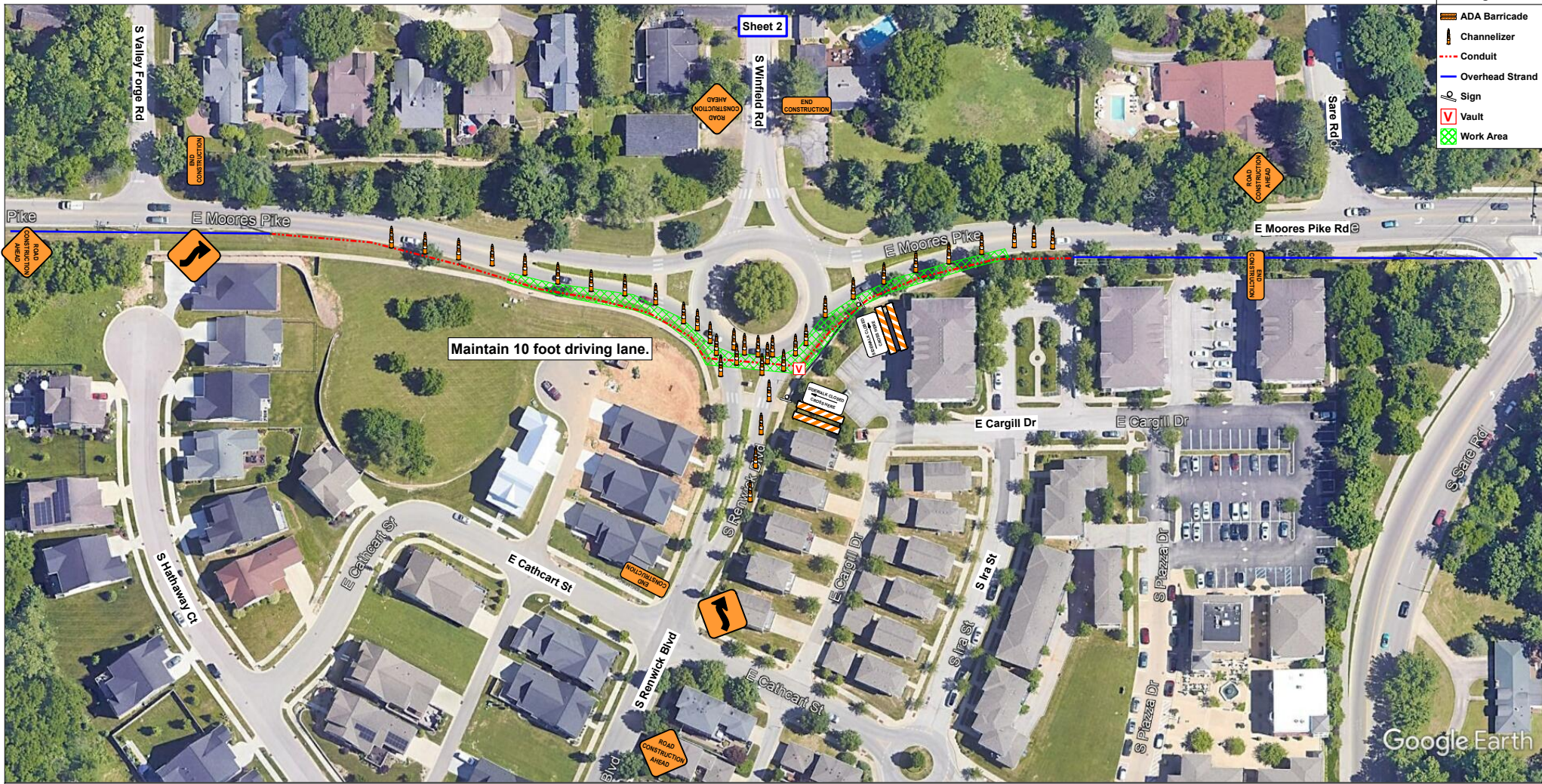

- Legend**
- ADA Barricade
  - Channelizer
  - Conduit
  - Overhead Strand
  - Sign
  - Vault
  - Work Area

Google Earth





# CITY OF BLOOMINGTON RIGHT-OF-WAY USE PERMIT APPLICATION

401 N Morton Street, Suite 130  
P.O. Box 100  
Bloomington, IN 47402

Phone: (812) 349-3913  
Fax: (812) 349-3520  
Email:  
engineering@bloomington.in.gov

ROW EXCAVATION  ROW USE

ADDRESS OF ROW ACTIVITY: E Queens Way

<b>A. APPLICANT/AGENT INFORMATION:</b>		<b>D. TRAFFIC CONTROL DEVICES*:</b>	
APPLICANT NAME: <u>Bret Simons</u>		<input checked="" type="checkbox"/> CONES <input type="checkbox"/> ARROWBOARD	
E-MAIL: <u>bret.simons@aeg.cc</u>		<input type="checkbox"/> LIGHTED BARRELS <input checked="" type="checkbox"/> TYPE 3 BARRICADES	
COMPANY: <u>Atlantic Engineering Group</u>		<input checked="" type="checkbox"/> FLAGGERS <input type="checkbox"/> BPD OFFICER	
ADDRESS: <u>P.O. Box 349</u>		*PROVIDING MUTCD COMPLIANT TEMPORARY TRAFFIC CONTROL DEVICES AND MAINTENANCE OF TRAFFIC (MOT) PLAN IS YOUR RESPONSIBILITY AND REQUIRED. See page 3 for additional MOT resources; the graph paper can be used for your MOT site plan if needed or you can submit a separate sheet	
CITY, STATE, ZIP: <u>Buford, GA 30515</u>			
24-HR EMERGENCY CONTACT NAME: <u>(706)654-2298</u>		<b>E. METERED PARKING SPACES NEEDED: <input type="checkbox"/> Y <input type="checkbox"/> N</b>	
24-HR CONTACT PHONE #: _____		IT IS THE RESPONSIBILITY OF THE APPLICANT TO RESERVE PARKING METER(S) APPLICATION LOCATED: <a href="https://bloomington.in.gov/transportation/parking/moving">https://bloomington.in.gov/transportation/parking/moving</a> OR CONTACT PARKING SERVICES WITH QUESTIONS AT (812)349-3436	
INSURANCE #*: <u>TB5-691-473497-082</u> COMPANY: <u>ACORD</u>		<b>F. IS THIS A <input type="checkbox"/> CBU* <input type="checkbox"/> COUNTY* <input type="checkbox"/> IU* <input type="checkbox"/> NP* PROJECT?</b>	
BOND #*: <u>1160465</u> COMPANY: <u>LEXON</u>		PROJECT NAME: <u>BLC02a-F13 E Queens Way</u>	
*INSURANCE & BOND MUST BE ON FILE WITH THE CITY BEFORE PERMIT WILL BE ISSUED		PROJECT #: <u>BLC02a-F13 E Queens Way</u>	
<b>**SUBCONTRACTOR INFORMATION**</b>		PROJECT MGR.: <u>Lex Mullins</u>	
(LIST ALL COMPANIES WORKING UNDER PRIMARY CONTRACTOR PERMIT)		PROJECT MGR. #: <u>215-847-8819</u>	
COMPANY NAME: _____		*CBU = CITY OF BLOOMINGTON UTILITIES *COUNTY = MONROE COUNTY	
<b>B. WORK DESCRIPTION:</b>		*IU = INDIANA UNIVERSITY *NP = NOT-FOR-PROFIT AGENCY	
<input type="checkbox"/> POD/DUMPSTER <input type="checkbox"/> CRANE <input type="checkbox"/> SCAFFOLDING <input checked="" type="checkbox"/> CONSTRUCTION USE*		<b>G. EXCAVATIONS:</b>	
(EXPLAIN): <u>Excavation</u>		SQ FT OF PAVEMENT* EXCAVATIONS : <u>N/A</u>	
*EXCAVATION, LONG TERM USE FOR STORAGE OF MATERIAL/EQUIPMENT/WALKAROUND		*PAVEMENT INCLUDES: IN OR UNDER CONCRETE, OR ASPHALT INCLUDING CURBS	
<b>C. RIGHT OF WAY TO BE USED/CLOSED:</b>		SQ FT OF NON-PAVEMENT* EXCAVATIONS: <u>265.42 Sq Ft</u>	
STREET NAME 1: <u>E Queens Way</u>		*DIRT, GRASS, GRAVEL, LANDSCAPE AREA OR OTHER UNPAVED SURFACE	
1ST INTERSECTING STREET NAME: _____		LINEAL FT OF BORE*: <u>22,691 Lineal Feet</u>	
2ND INTERSECTING STREET NAME: _____		*BORE PITS SHALL BE CALCULATED AS SQ FT EXCAVATIONS	
<input type="checkbox"/> ROAD CLOSURE <input checked="" type="checkbox"/> LANE CLOSURE 1 <input checked="" type="checkbox"/> 2 <input type="checkbox"/> 3 <input type="checkbox"/>		# OF POLE INSTALLATIONS/REMOVAL: <u>N/A</u>	
<input checked="" type="checkbox"/> SIDEWALK* <input type="checkbox"/> BIKE LANE <input type="checkbox"/> OTHER		SQ FT OF SIDEWALK RECONSTRUCTION*: <u>N/A</u>	
TRANSIT STOP? <input type="checkbox"/> Y <input type="checkbox"/> N PARKING LANE(S)** <input type="checkbox"/> Y <input type="checkbox"/> N **NON-METERED		*CONCRETE OR ASPHALT SIDEWALK/PATH BEING IMPROVED/REPLACED	
START DATE: <u>Feb 3rd</u> END DATE: _____ # OF DAYS*: <u>30</u>		SQ FT OF SIDEWALK NEW CONSTRUCTION*: <u>N/A</u>	
STREET NAME 2: _____		*CONCRETE OR ASPHALT SIDEWALK/PATH THAT IS NEW INFRASTRUCTURE	
1ST INTERSECTING STREET NAME: _____		#RESIDENTIAL DRIVEWAY INSTALLATION: <u>N/A</u>	
2ND INTERSECTING STREET NAME: _____		 <p>TO SUBMIT A LOCATE REQUEST 24 HRS A DAY, 7 DAYS A WEEK CALL 811 OR 800-382-5544 CALL 2 WORKING DAYS BEFORE YOU DIG. IT'S THE LAW.</p>	
<input type="checkbox"/> ROAD CLOSURE <input type="checkbox"/> LANE CLOSURE 1 <input type="checkbox"/> 2 <input type="checkbox"/> 3 <input type="checkbox"/>			
<input type="checkbox"/> SIDEWALK* <input type="checkbox"/> BIKE LANE <input type="checkbox"/> OTHER		<b>H. INDEMNIFICATION AGREEMENT:</b>	
TRANSIT STOP? <input type="checkbox"/> Y <input type="checkbox"/> N PARKING LANE(S)** <input type="checkbox"/> Y <input type="checkbox"/> N **NON-METERED		The petitioner/applicant hereby agrees to hold harmless, defend and to indemnify the City of Bloomington from or against all claims, action, damages and expenses, including but not limited to reasonable attorney's fees or any alleged injury and/or death to any person or damage to any property arising, or alleged to have arisen out of any act of commission or omission on the part of the petitioner/applicant, his/her heirs, successors, or assigns regardless of whether such acts are the direct or indirect result of the public right-of-way use pursuant to this permit grant.	
START DATE: _____ END DATE: _____ # OF DAYS*: _____		I AFFIRM, UNDER THE PENALTIES FOR PERJURY, THAT THE FOREGOING REPRESENTATIONS ARE TRUE.	
*SIDEWALK CLOSURES FOR A PERIOD OR PERIODS TOTALING 24HRS OR MORE SHALL INSTALL A WALKAROUND UNLESS OTHERWISE APPROVED DURING REVIEW		PRINT NAME: <u>Bret Simons</u>	
<b>STANDARD CLOSURE HOURS MON-FRI*: 9:00 AM - 3:00 PM &amp; 6:00 PM - 9:00 PM</b>		SIGNATURE: <u>Bret Simons</u>	
STANDARD CLOSURE HOURS <input checked="" type="checkbox"/> *NON-STANDARD CLOSURE HOURS <input type="checkbox"/>		DATE: <u>1/6/2023</u>	
REQUESTED CLOSURE HOURS: _____ AM - _____ PM			
*non-standard hours may not be allowed near schools, on arterials, or other circumstances and are subject to approval during the permitting process			
BMC 14.09.040 allows work from 6 AM to 10 PM without violating the noise ordinance (7AM to 9PM for pneumatic hammers)			

For Administration Use Only (applicable to CLOSURE approval)

Approved By: \_\_\_\_\_  BPW  City Engineer  Director Date: \_\_\_\_\_

Staff Representative: \_\_\_\_\_ Phone#: \_\_\_\_\_ Date: \_\_\_\_\_



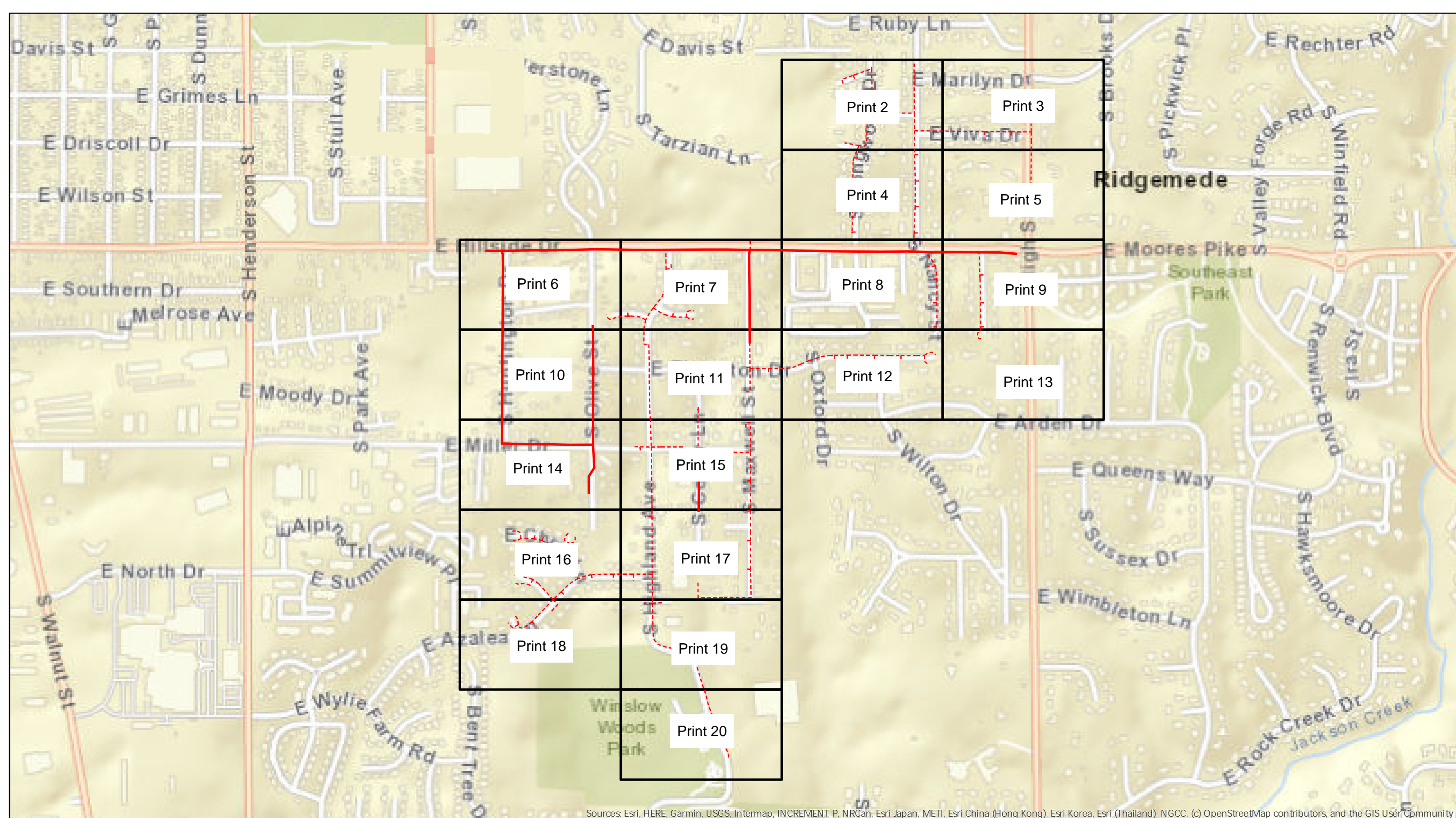

Sources: Esri, HERE, Garmin, USGS, Intermap, INCREMENT P, NRCan, Esri Japan, METI, Esri China (Hong Kong), Esri Korea, Esri (Thailand), NGCC, (c) OpenStreetMap contributors, and the GIS User Community



Legend BLC02a-F14\_S Maxwell St

- Overhead Strand
- - - Conduit
- Grids

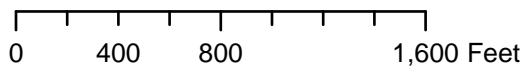

City of Bloomington, IN Permit:  
Design View

INI	BY	DATE	DESCRIPTION



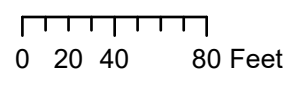
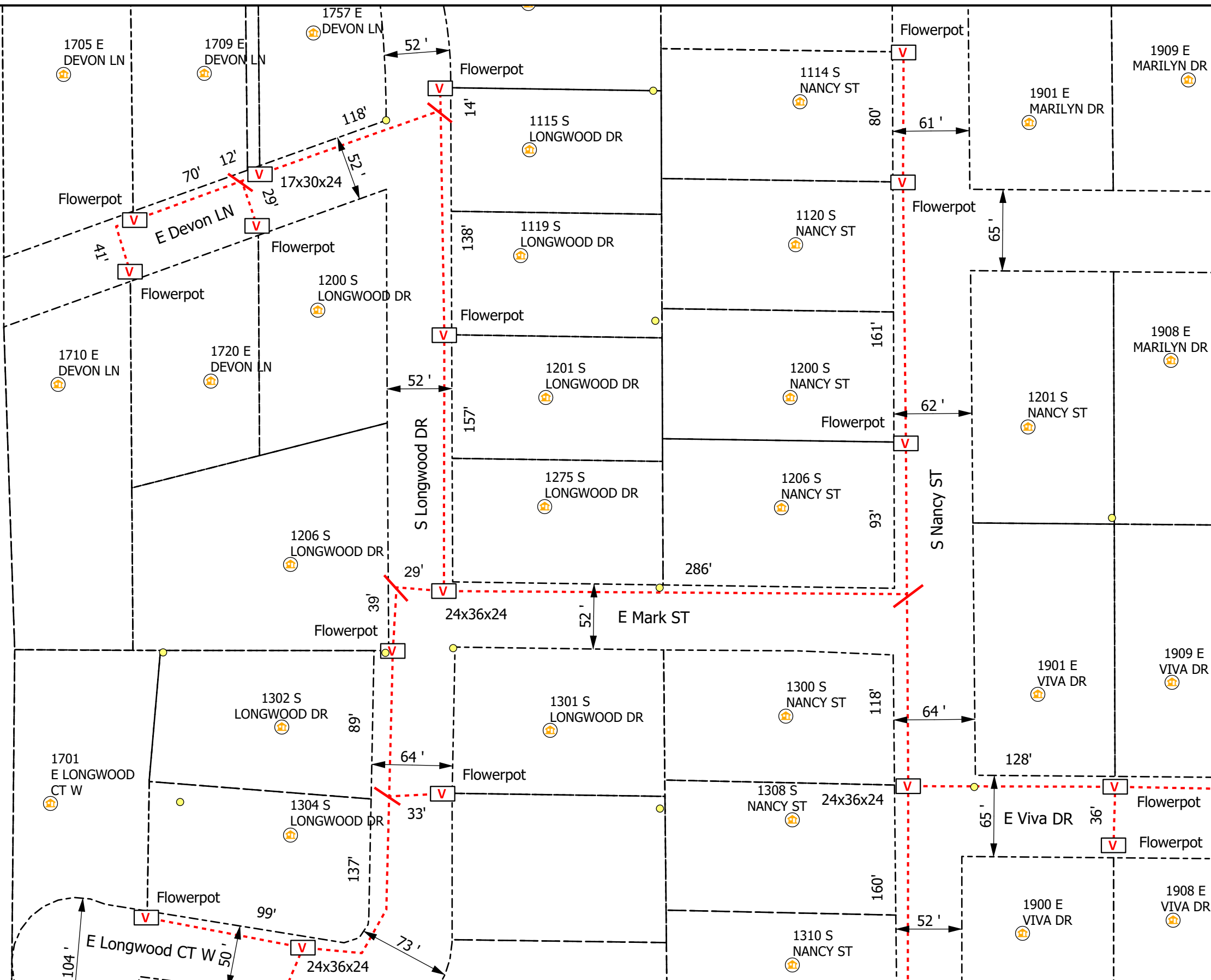

**Legend**

- Poles
- V Vaults
- Overhead Strand
- - - Conduit
- Bloomington\_Parcels
- R Risers
- ⊙ Address
- Y Anchor
- ← Sidewalk
- Grids

All Flowerpots 12" DIA



City of Bloomington, IN Permit:  
Design View

INI	BY	DATE	DESCRIPTION



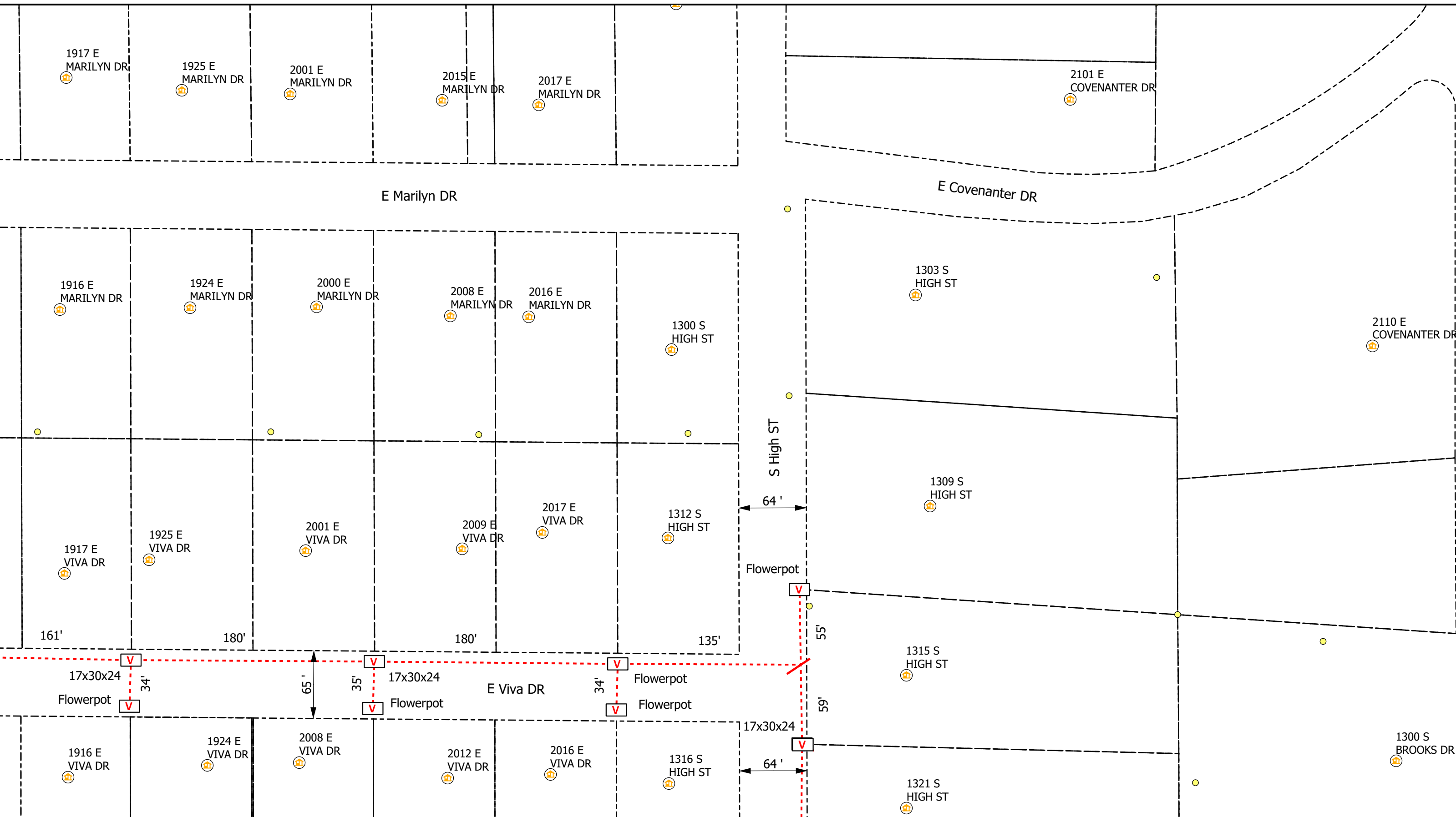

**AEG**

0 20 40 80 Feet

**Legend**

- Poles
- Ⓜ Bloomington\_Parcels
- Ⓜ Risers
- Ⓜ Address
- Overhead Strand
- - - Conduit
- Ⓜ Anchor
- Ⓜ Sidewalk
- Ⓜ Grids

All Flowerpots 12" DIA

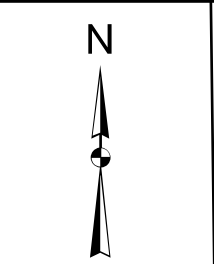

City of Bloomington, IN Permit:  
Design View

INI	BY	DATE	DESCRIPTION

Print 3 of 20

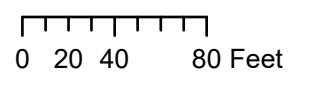
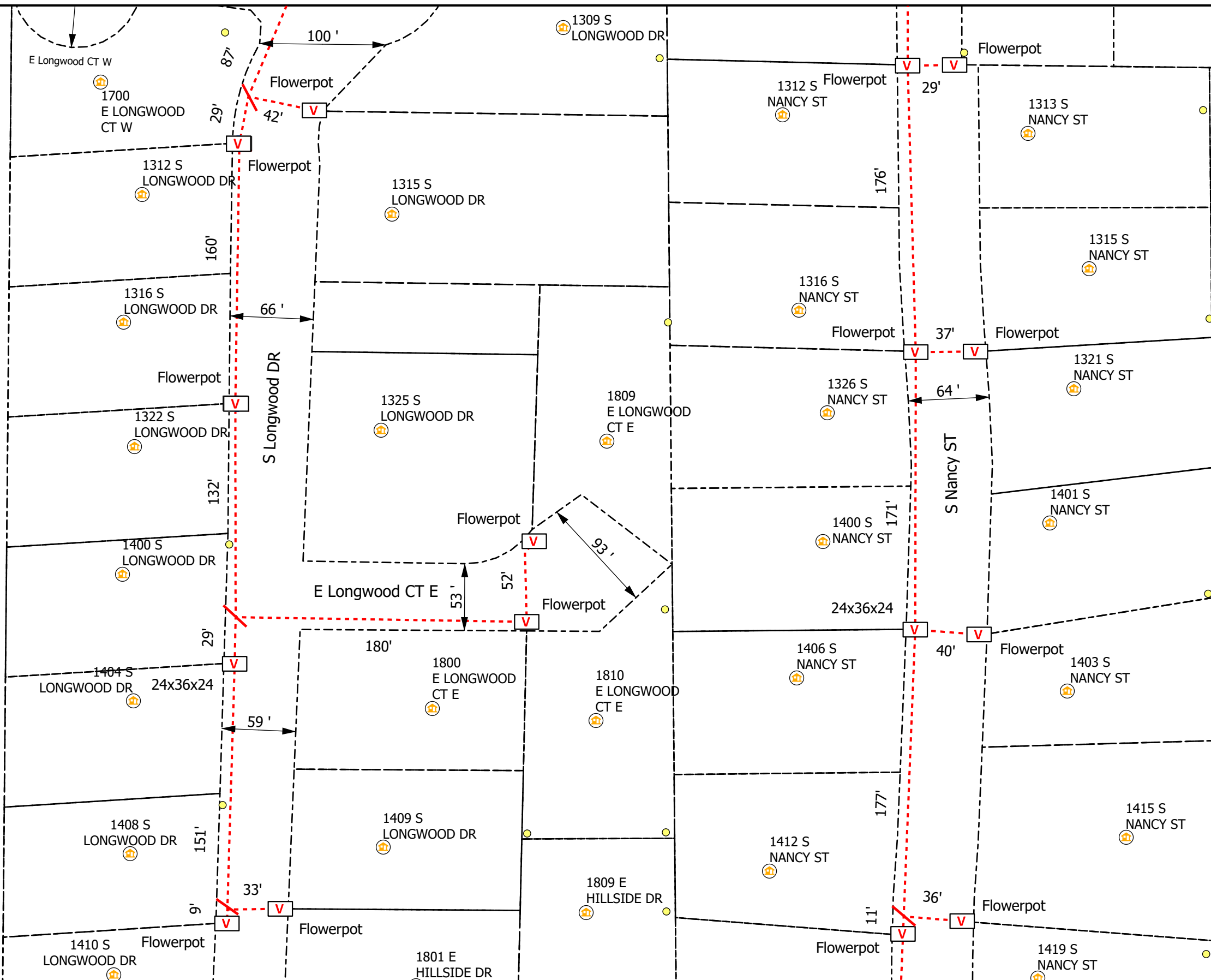

**Legend**

- Poles
- V Vaults
- Overhead Strand
- Conduit
- Bloomington\_Parcels
- R Risers
- ⊙ Address
- Y Anchor
- ← Sidewalk
- Grids

All Flowerpots 12" DIA



City of Bloomington, IN Permit:  
Design View

INI	BY	DATE	DESCRIPTION





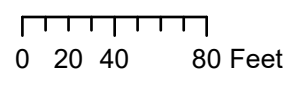
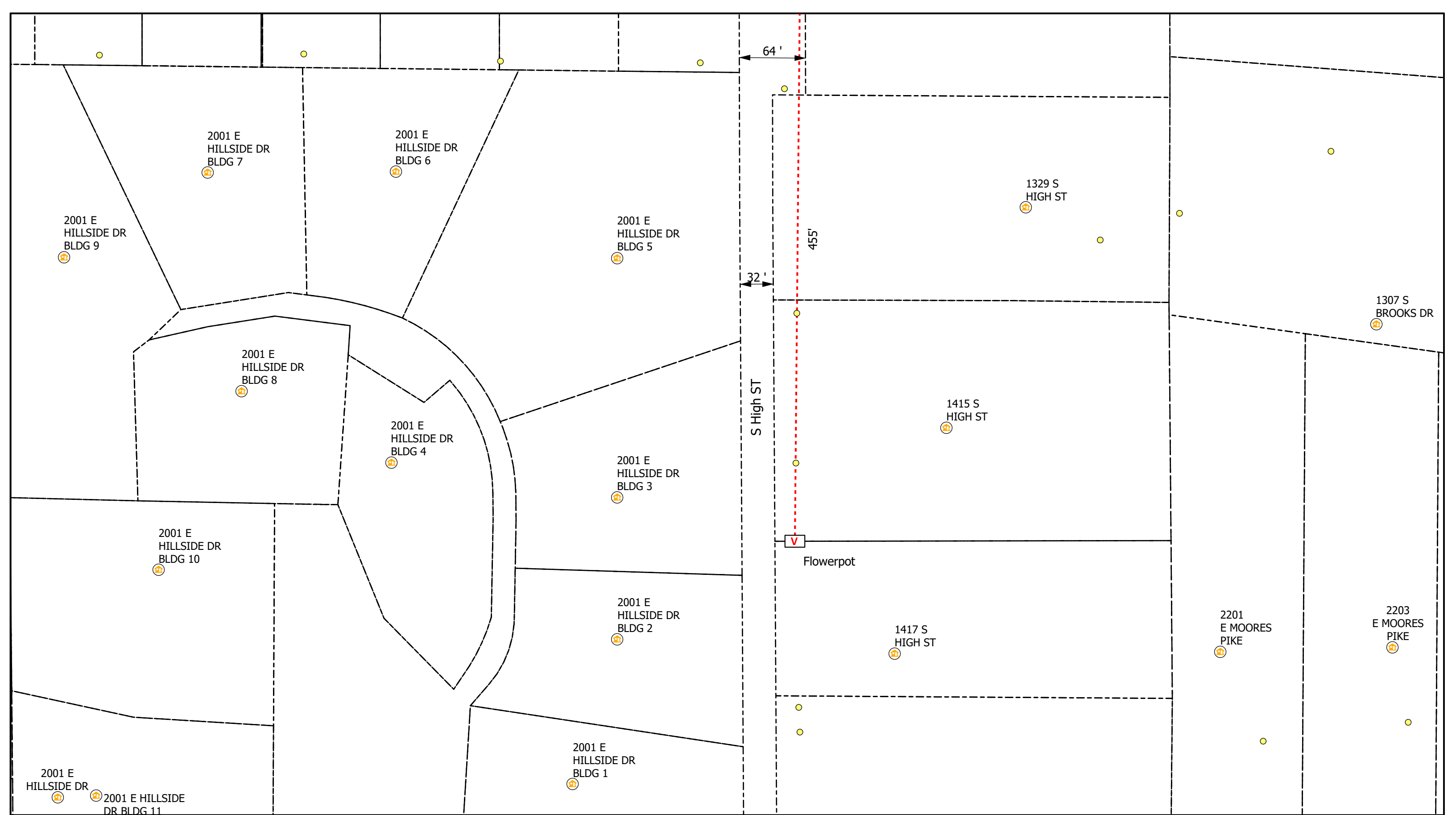

**Legend**

- Poles
- V Vaults
- Overhead Strand
- Conduit
- Bloomington\_Parcels
- R Risers
- A Address
- Y Anchor
- ← Sidewalk
- Grids

All Flowerpots 12" DIA



City of Bloomington, IN Permit:  
Design View

INI	BY	DATE	DESCRIPTION



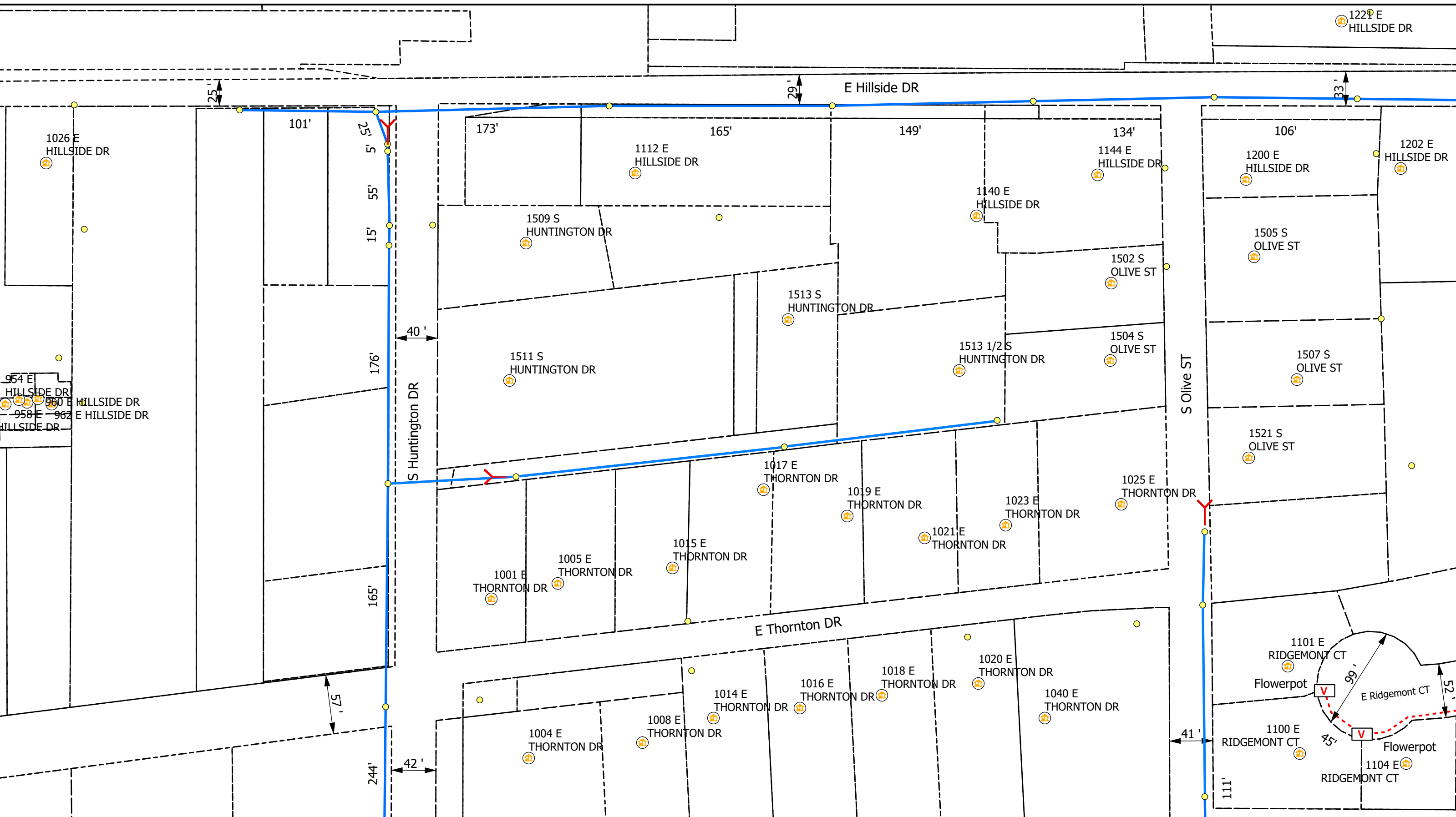

**Legend**

- Poles
- V Vaults
- Overhead Strand
- Conduit
- Bloomington\_Parcels
- R Risers
- A Address
- Y Anchor
- ← Sidewalk
- Grids

All Flowerpots 12" DIA

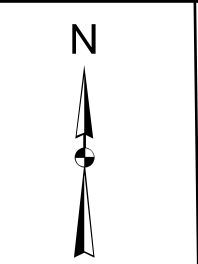

City of Bloomington, IN Permit:  
Design View

INI	BY	DATE	DESCRIPTION

Print 6 of 20

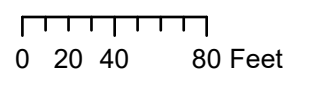
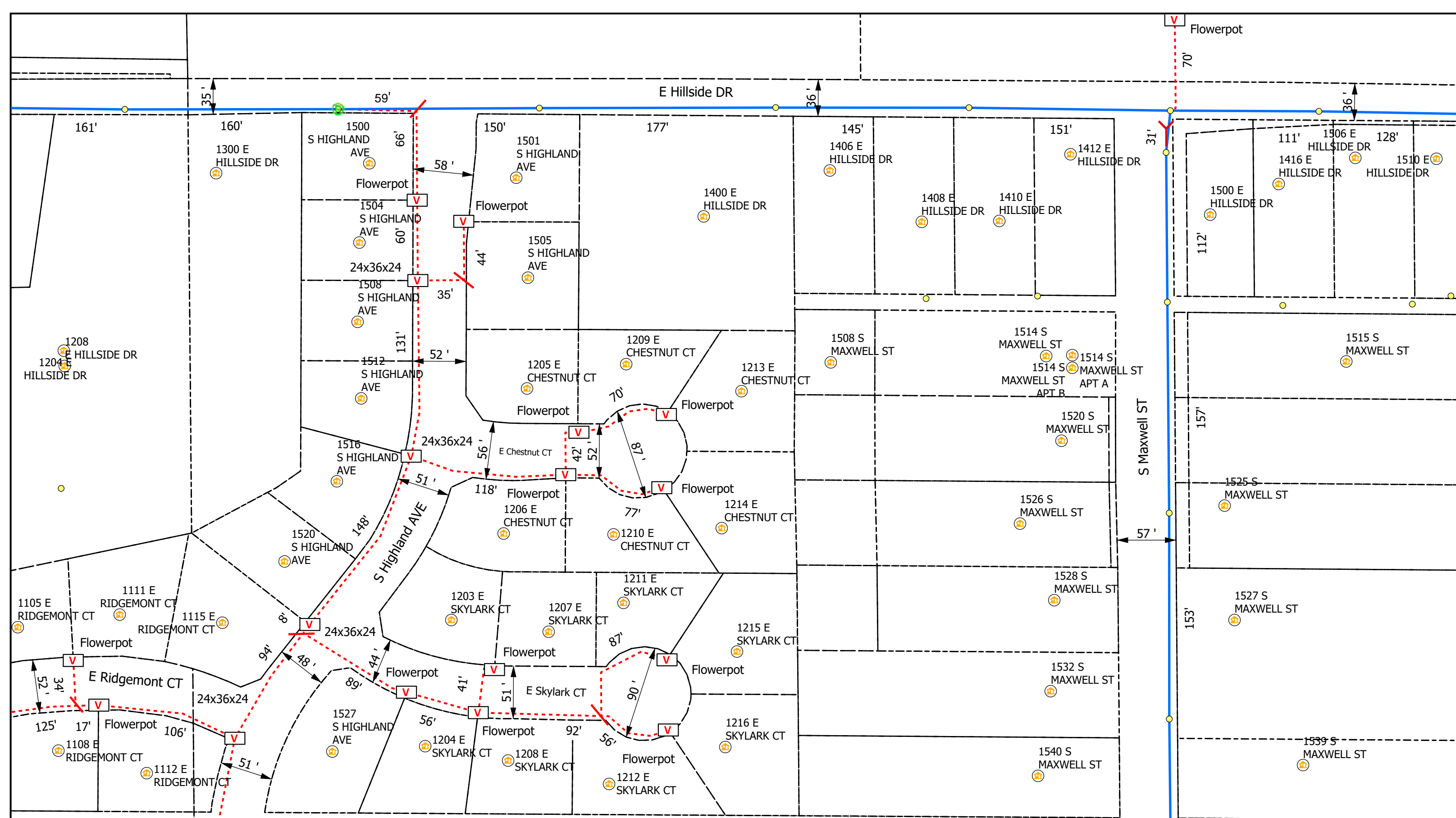

**Legend**

- Poles
- V Vaults
- Overhead Strand
- Conduit
- Bloomington\_Parcels
- Ⓡ Risers
- Ⓜ Address
- Y Anchor
- ← Sidewalk
- Grids

All Flowerpots 12" DIA



City of Bloomington, IN Permit:  
Design View

INI	BY	DATE	DESCRIPTION



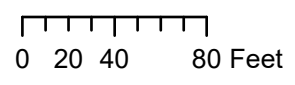
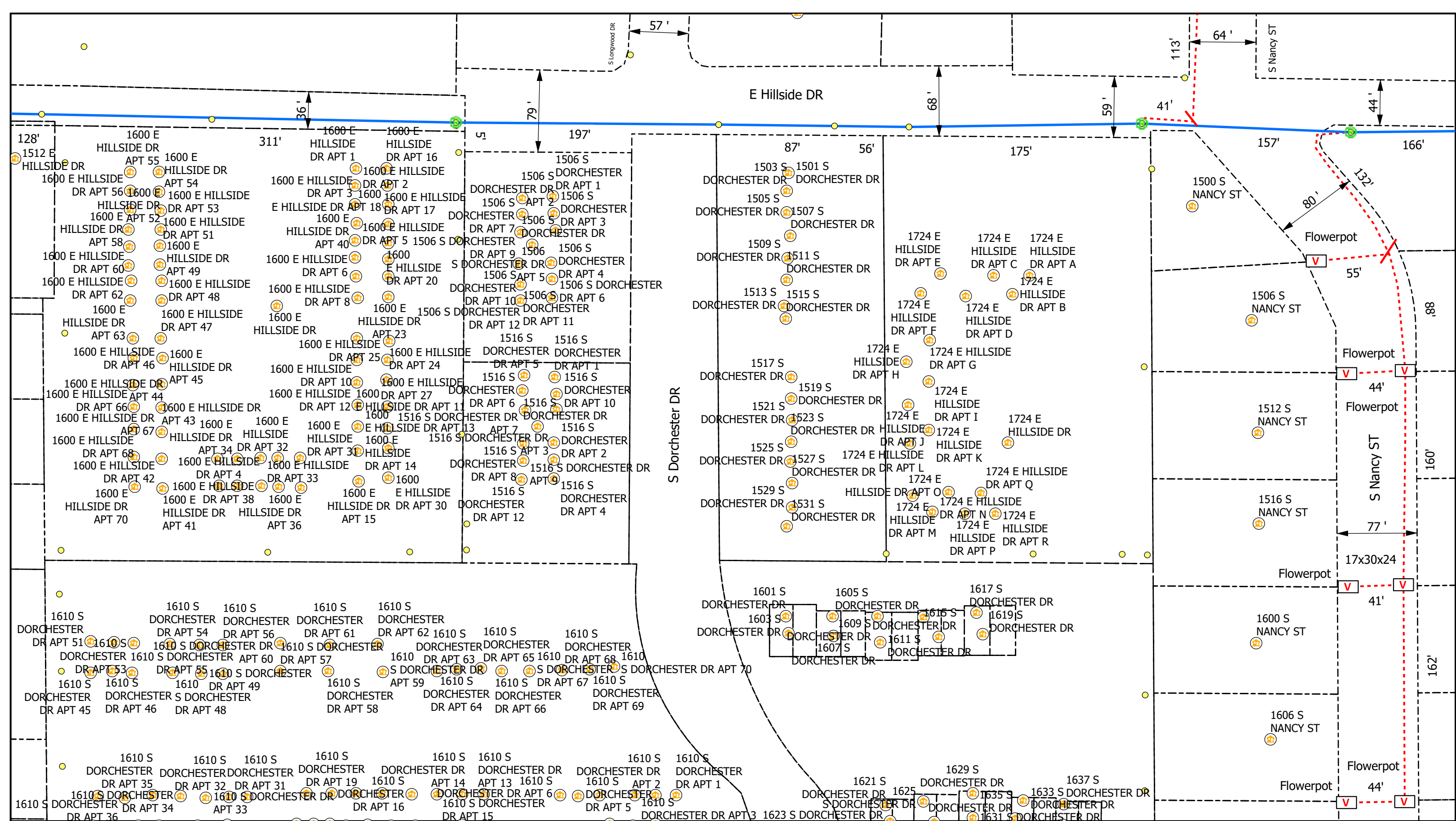

**Legend**

- Poles
- Vaults
- Overhead Strand
- Conduit
- Bloomington\_Parcels
- Risers
- Address
- Anchor
- Sidewalk
- Grids

All Flowerpots 12" DIA



City of Bloomington, IN Permit:  
Design View

INI	BY	DATE	DESCRIPTION





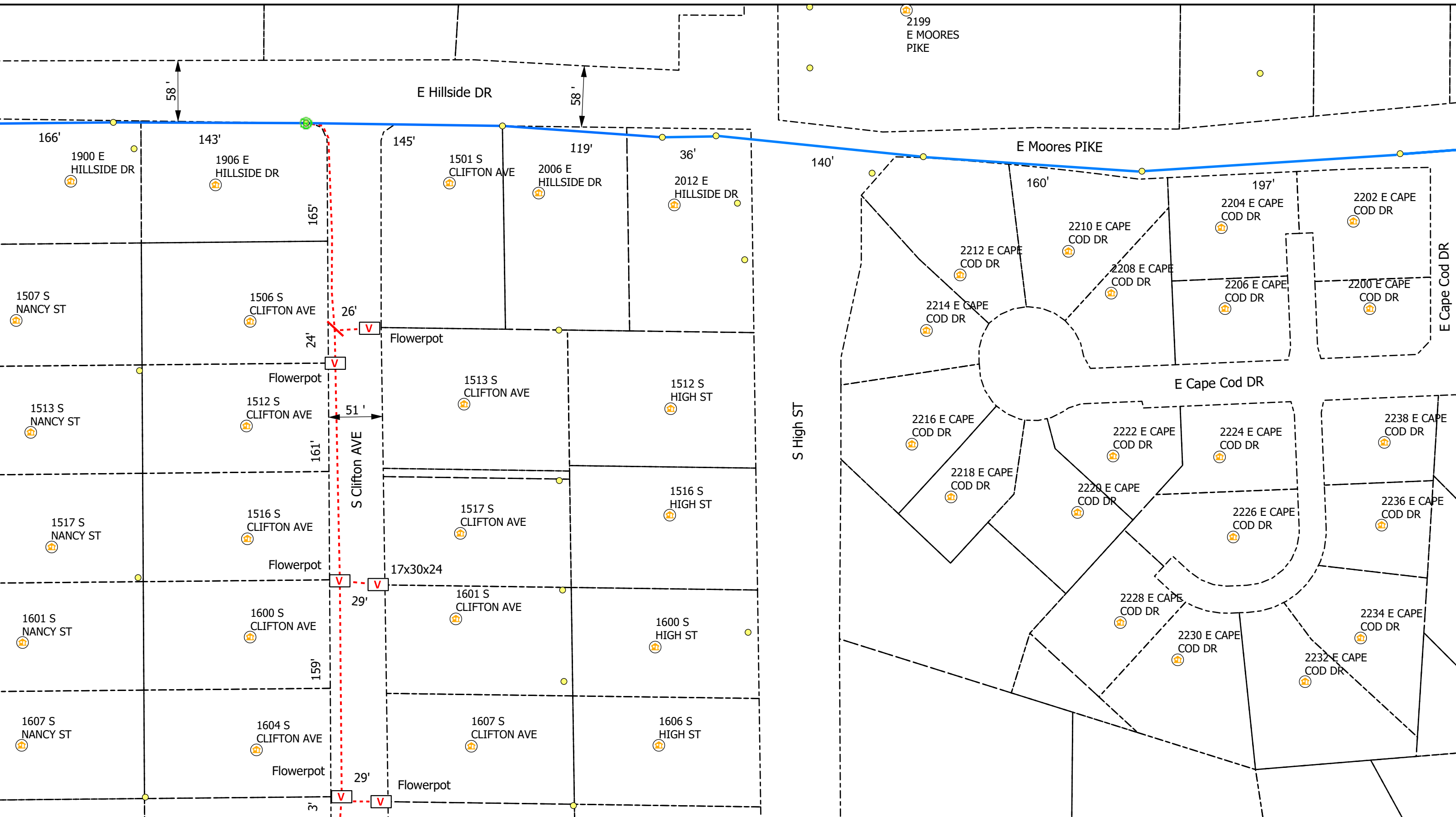

**AEG**

0 20 40 80 Feet

**Legend**

- Poles
- Ⓜ Vaults
- Overhead Strand
- - - Conduit
- Ⓜ Bloomington\_Parcels
- Ⓜ Risers
- Ⓜ Address
- Ⓜ Anchor
- Ⓜ Sidewalk
- Ⓜ Grids

All Flowerpots 12" DIA

City of Bloomington, IN Permit:  
Design View

INI	BY	DATE	DESCRIPTION

Print 9 of 20

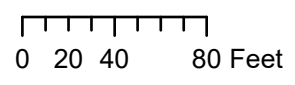
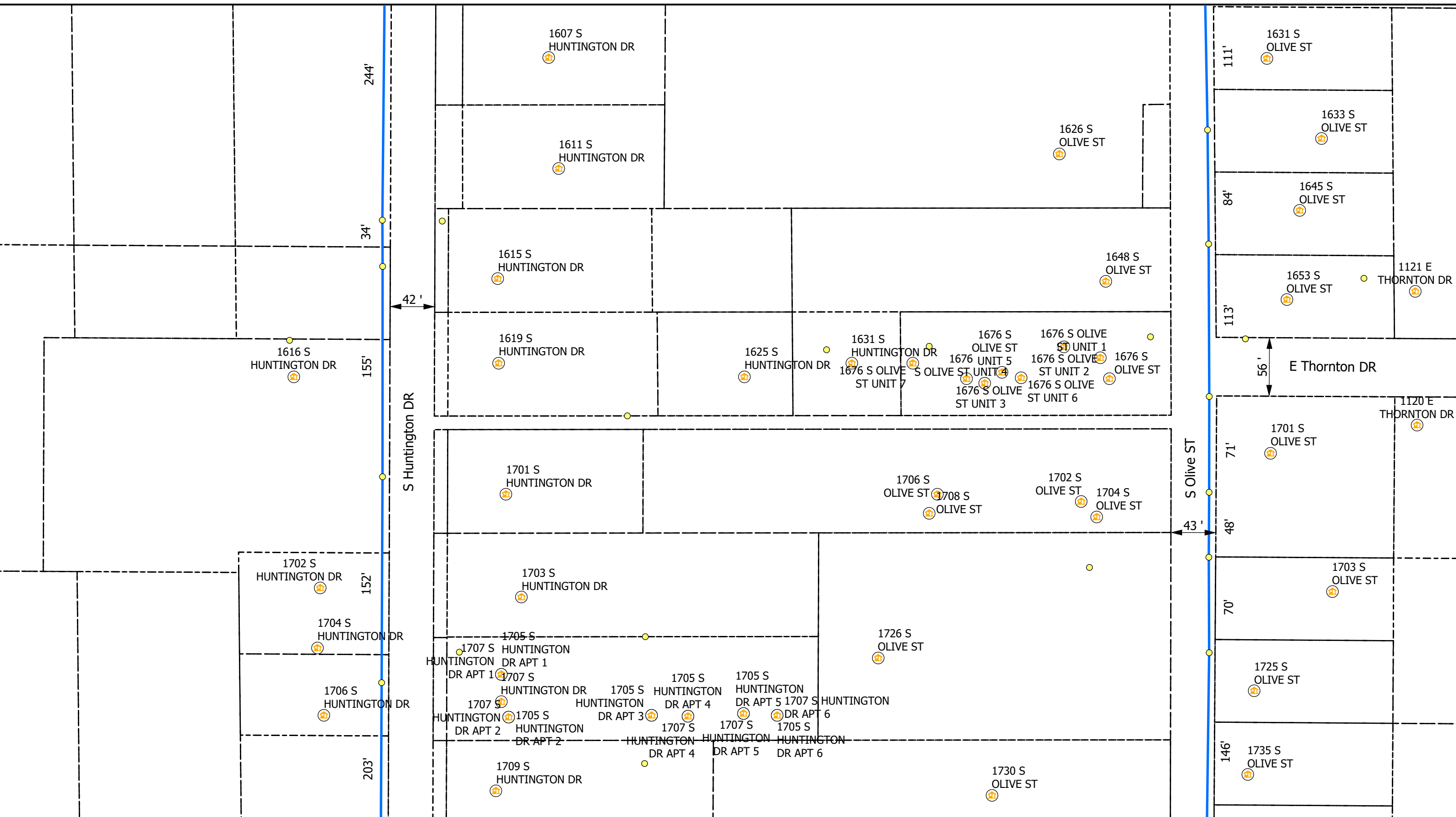

**Legend**

- Poles
- Vaults
- Overhead Strand
- Conduit
- Bloomington\_Parcels
- Risers
- Address
- Anchor
- Sidewalk
- Grids

All Flowerpots 12" DIA



City of Bloomington, IN Permit:  
Design View

INI	BY	DATE	DESCRIPTION



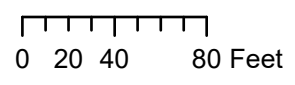
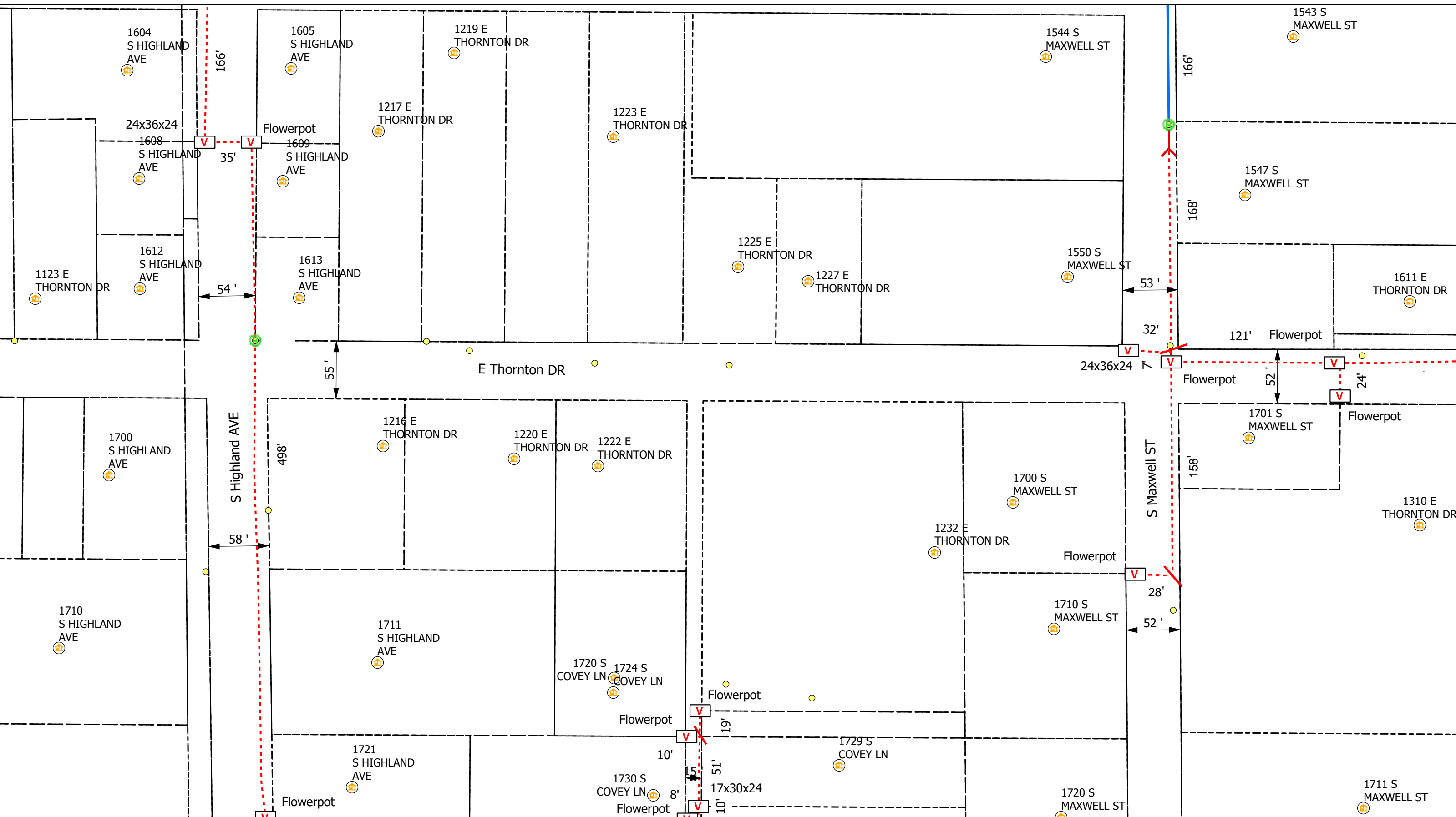

**Legend**

- Poles
- Vaults
- Overhead Strand
- Conduit
- Bloomington\_Parcels
- Risers
- Address
- Anchor
- Sidewalk
- Grids

All Flowerpots 12" DIA



City of Bloomington, IN Permit:  
Design View

INI	BY	DATE	DESCRIPTION



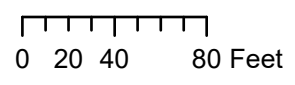
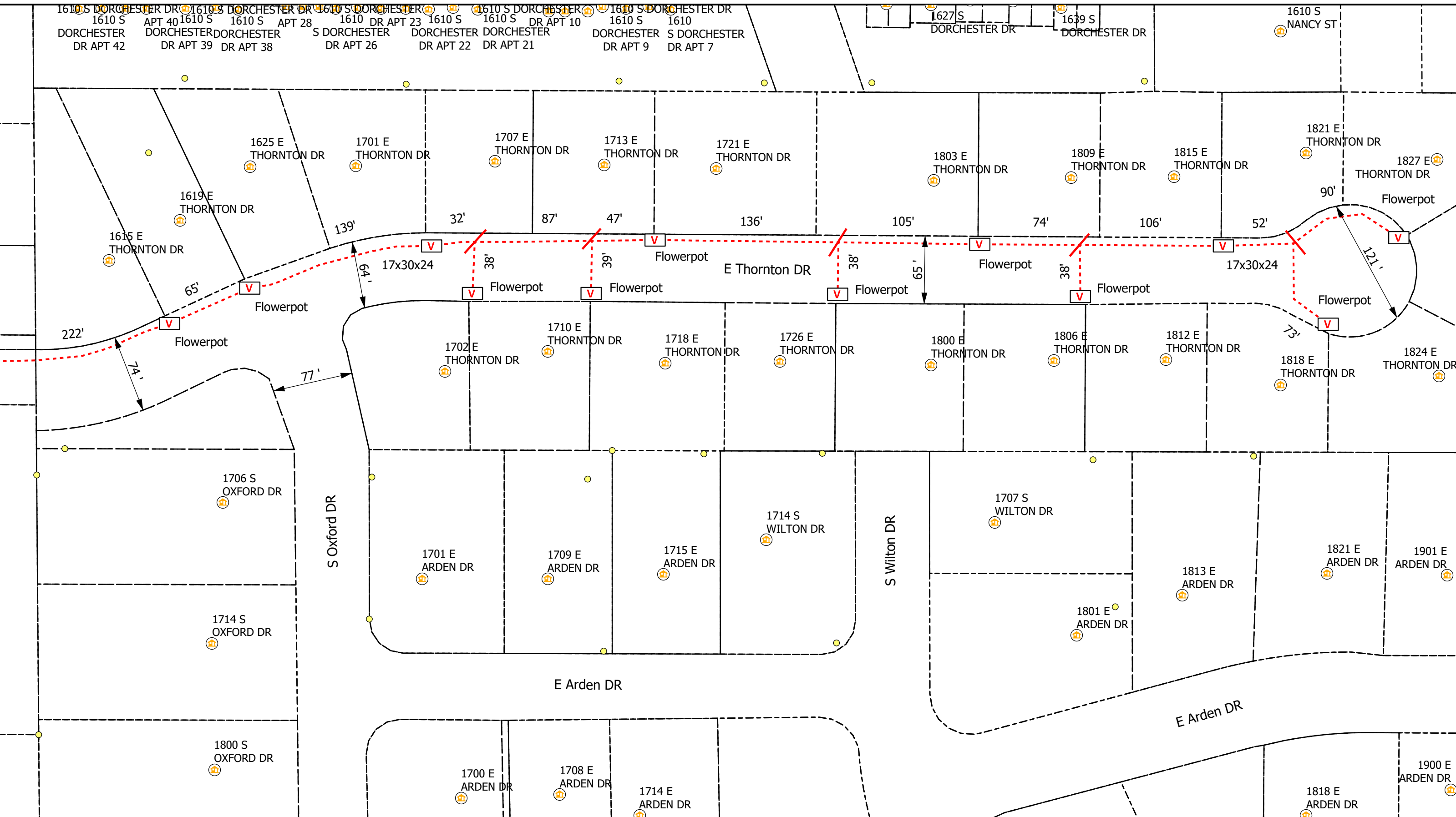

**Legend**

- Poles
- Vaults
- Overhead Strand
- Conduit
- Bloomington\_Parcels
- Risers
- Address
- Anchor
- Sidewalk
- Grids

All Flowerpots 12" DIA



City of Bloomington, IN Permit:  
Design View

INI	BY	DATE	DESCRIPTION





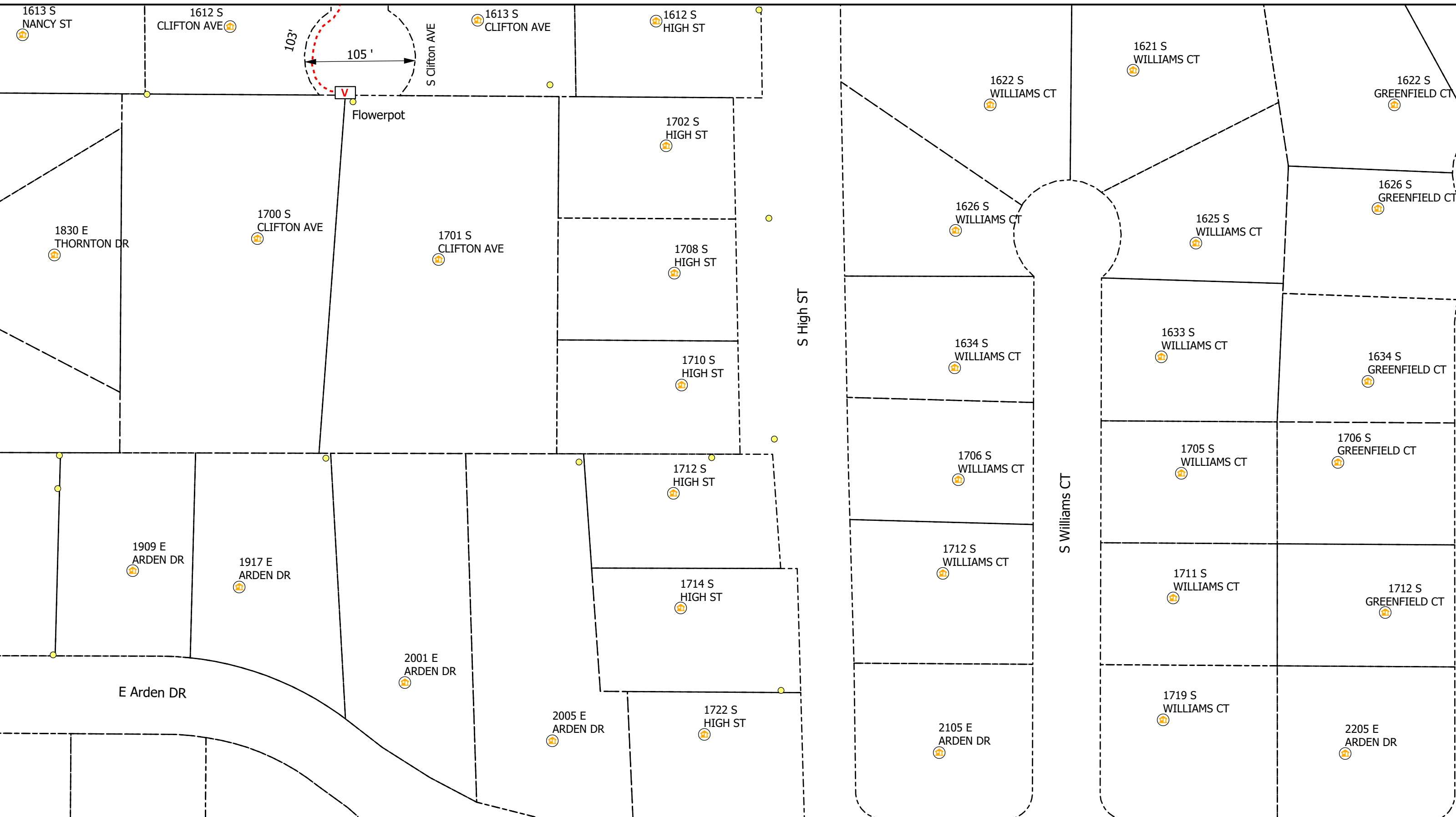

0 20 40 80 Feet

**Legend**

- Poles
- Vaults
- Overhead Strand
- Conduit
- Bloomington\_Parcels
- Risers
- Address
- Anchor
- Sidewalk
- Grids

All Flowerpots 12" DIA

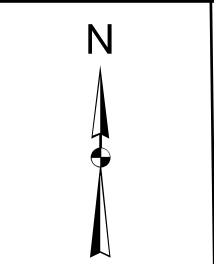

City of Bloomington, IN Permit:  
Design View

INI	BY	DATE	DESCRIPTION

Print 13 of 20

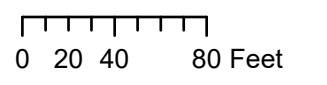
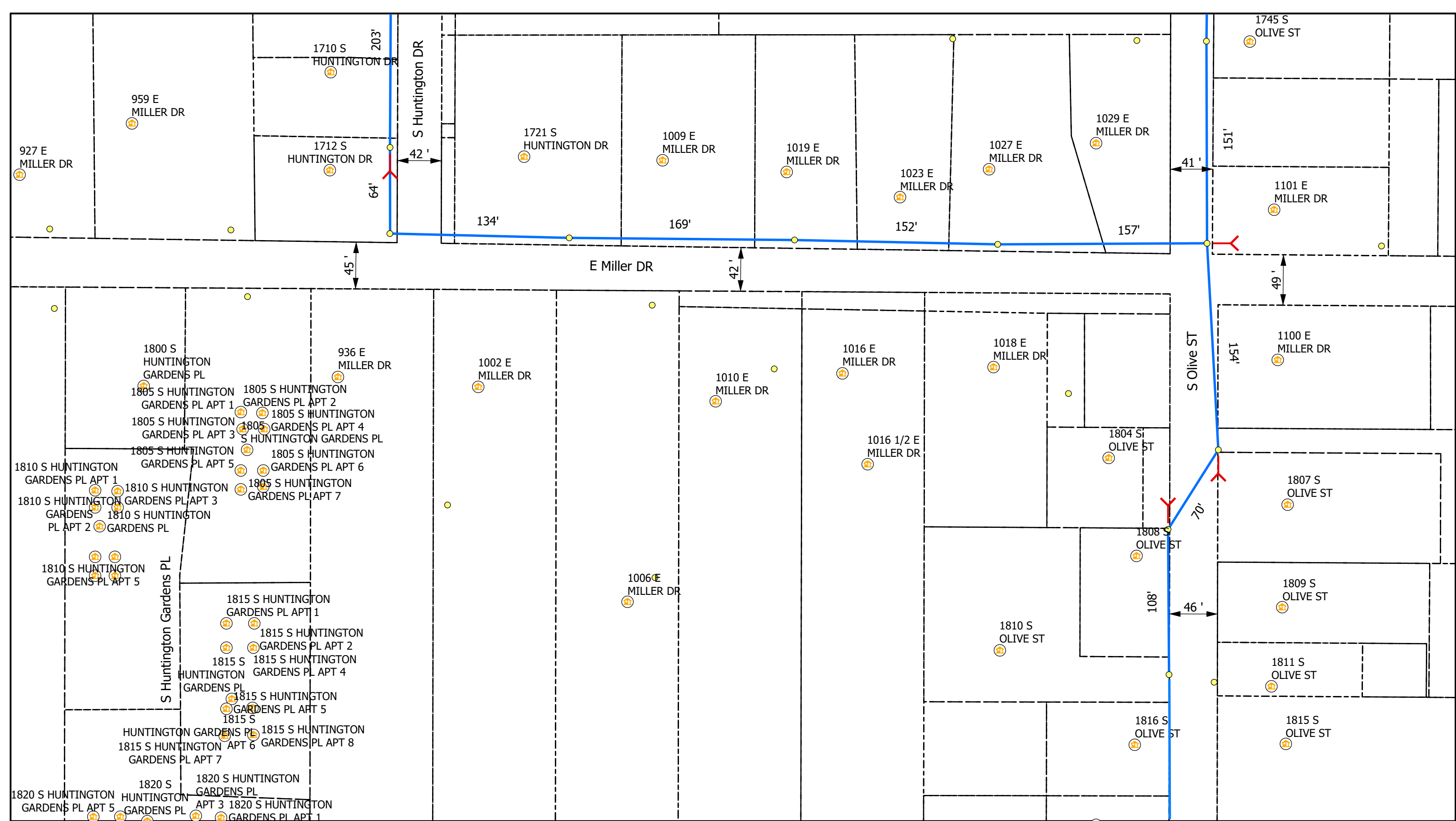

**Legend**

- Poles
- Vaults
- Overhead Strand
- Conduit
- Bloomington\_Parcels
- Risers
- Address
- Anchor
- Sidewalk
- Grids

All Flowerpots 12" DIA



City of Bloomington, IN Permit:  
Design View

INI	BY	DATE	DESCRIPTION



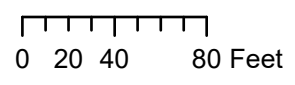
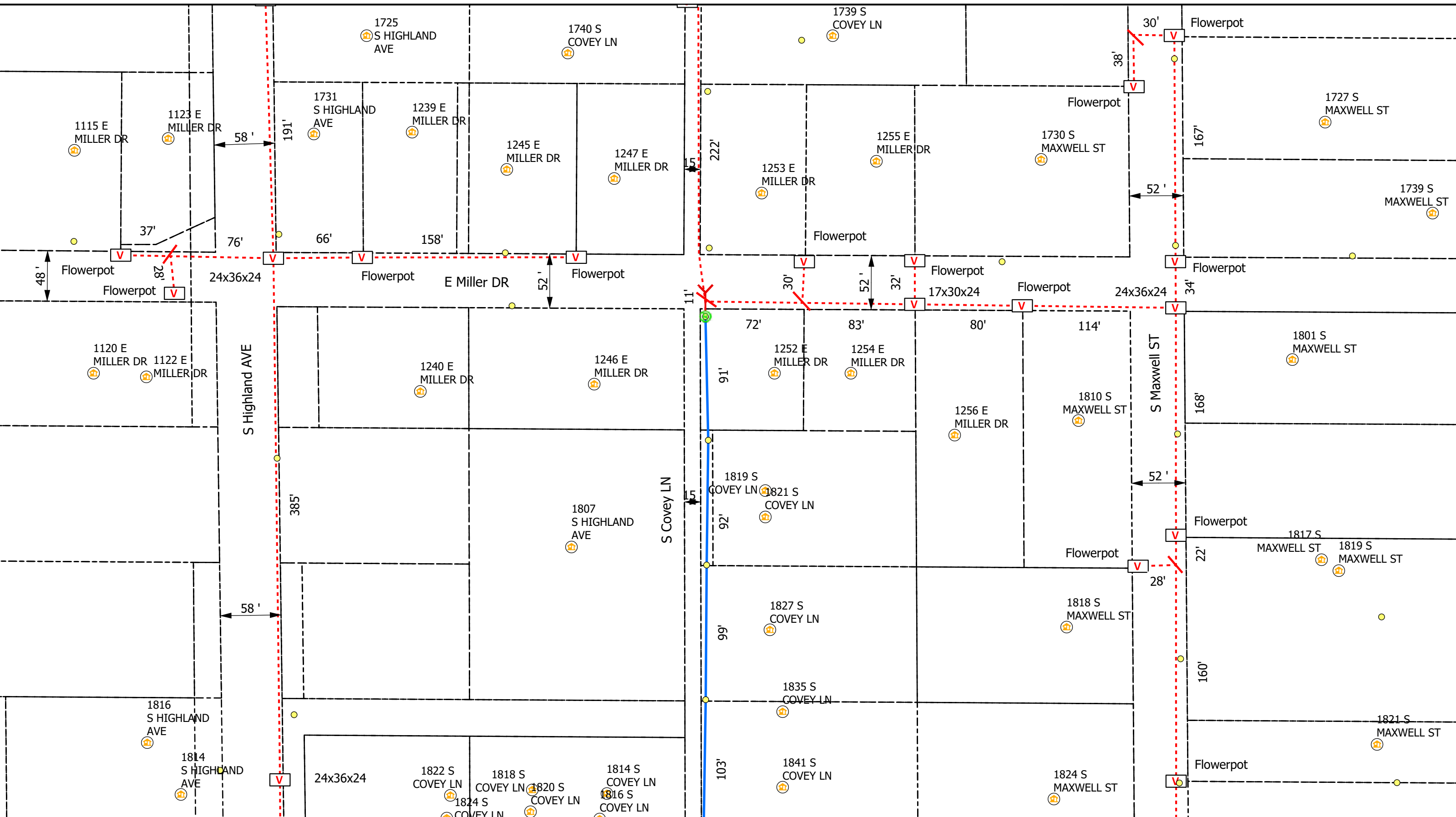

**Legend**

- Poles
- V Vaults
- Overhead Strand
- Conduit
- Bloomington\_Parcels
- R Risers
- A Address
- Y Anchor
- ← Sidewalk
- Grids

All Flowerpots 12" DIA



City of Bloomington, IN Permit:  
Design View

INI	BY	DATE	DESCRIPTION









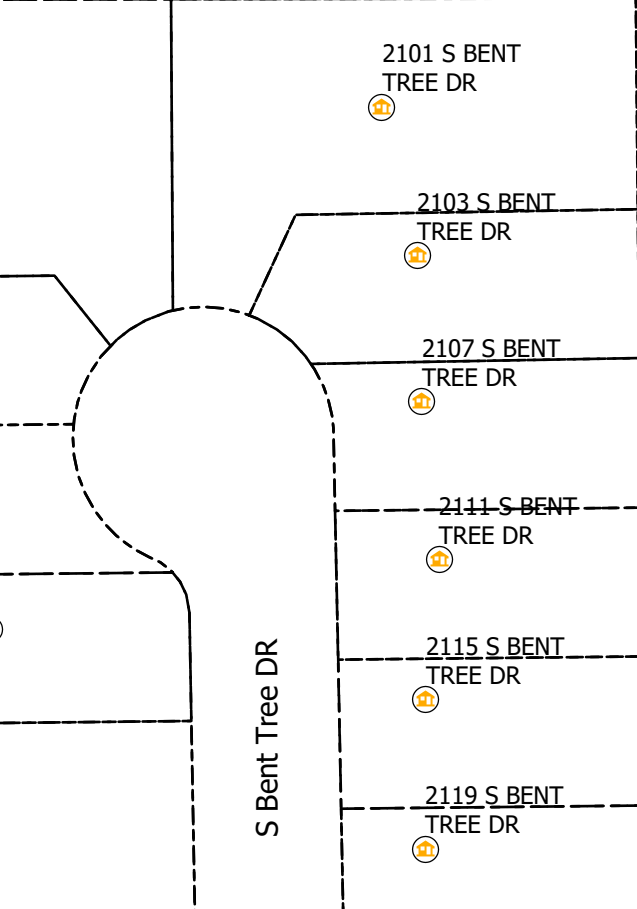
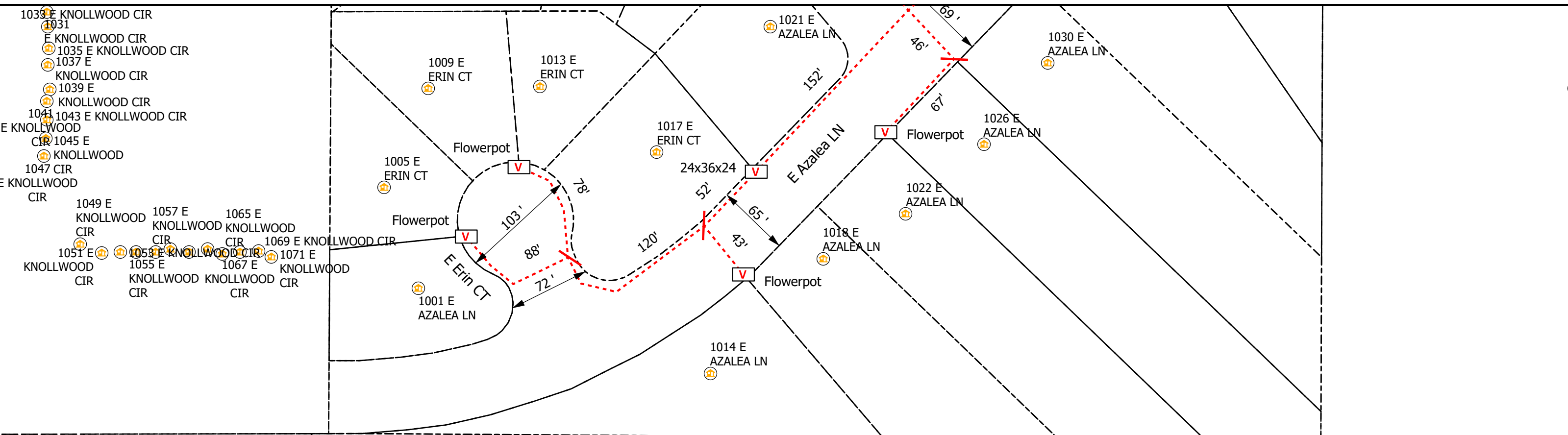

**Legend**

- Poles
- Vaults
- Overhead Strand
- Conduit
- Bloomington\_Parcels
- Risers
- Address
- Anchor
- Sidewalk
- Grids

All Flowerpots 12" DIA



City of Bloomington, IN Permit:  
Design View

INI	BY	DATE	DESCRIPTION



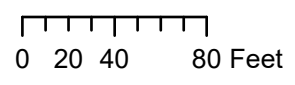
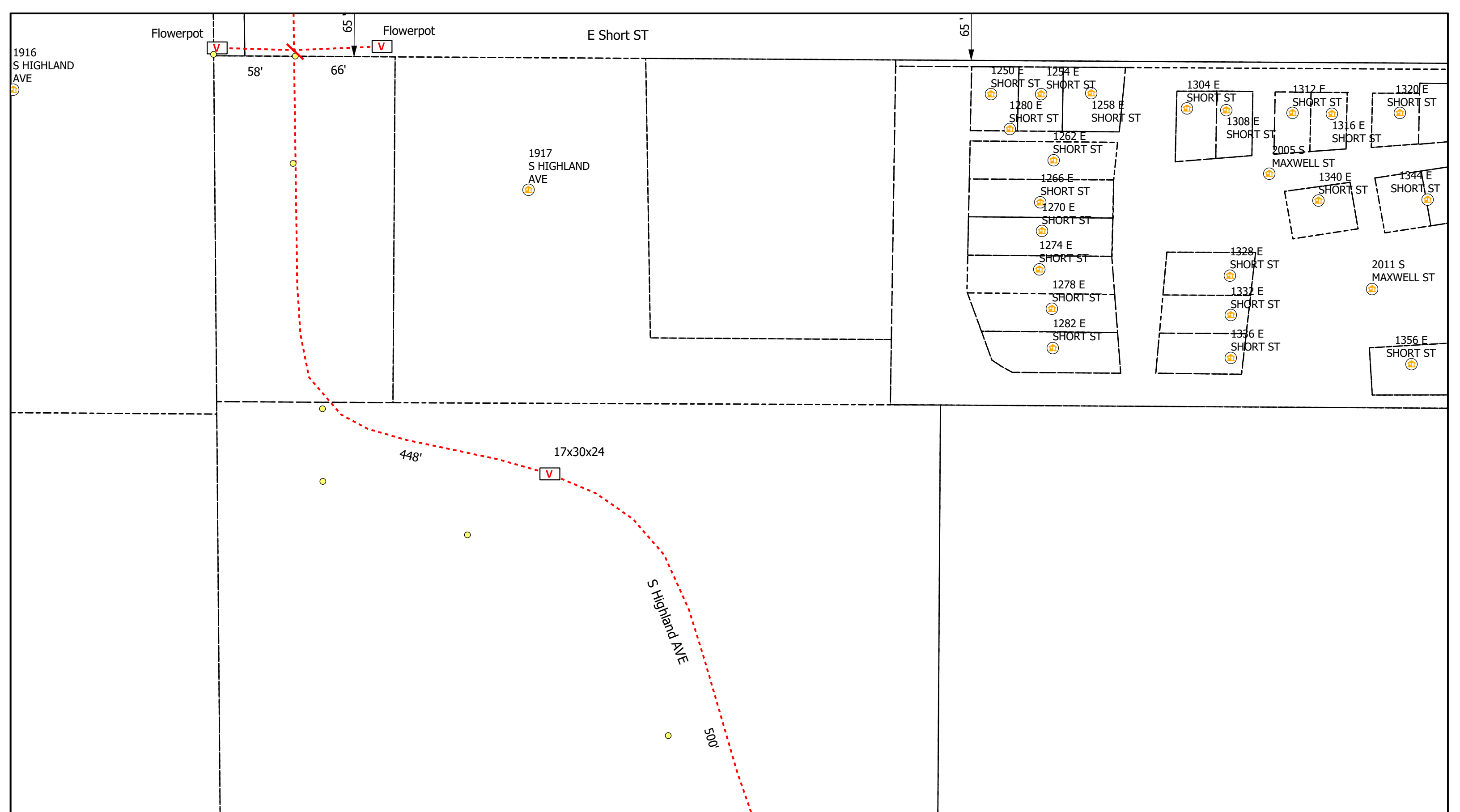

**Legend**

- Poles
- V Vaults
- Overhead Strand
- - - Conduit
- Bloomington\_Parcels
- R Risers
- 🏠 Address
- Y Anchor
- ↔ Sidewalk
- Grids

All Flowerpots 12" DIA



City of Bloomington, IN Permit:  
Design View

INI	BY	DATE	DESCRIPTION



2125  
S HIGHLAND  
AVE

2120  
S HIGHLAND  
AVE

V  
Flowerpot

S Highland AVE

V  
17x30x24

5A'

307'

**Legend**

- Poles
- V Vaults
- Overhead Strand
- - - Conduit
- Bloomington\_Parcels
- R Risers
- A Address
- Y Anchor
- ← Sidewalk
- Grids

All Flowerpots 12" DIA



City of Bloomington, IN Permit:  
Design View

INI	BY	DATE	DESCRIPTION



0 20 40 80 Feet



# Carlton® PV-Mold® Nonmetallic Pole Riser System

Carlton PV-Mold is a nonmetallic pole riser system designed to protect communications power cable installed on poles.

## Features:

- Meets or exceeds requirements outlined in the National Electric Safety Code (NESC).
- Designed in accordance with NEMA TC-19 specifications.
- Ultraviolet, cold temperature and corrosive atmosphere resistant.
- Schedule 40 wall meets Schedule 80 PVC conduit impact requirements per NEMA TC-19.
- No grounding required.
- Belled end fits over each added section or conduit.
- Flame retardant.
- Requires no maintenance.
- PV-Mold acts as an insulator against electrical shock.
- Interchangeable parts and accessories to match the needs of specific requirements.



Steel U-Guard requires grounding strapping and does not have belled ends.



PV-Mold has belled ends, flanged design and does not require grounding.

## Flanged Overall Length 10 Feet, Including Bell

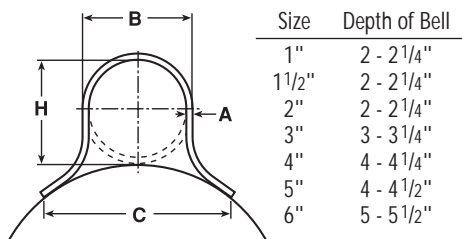

Slots are 1/2" from side to side, and allow for expansion and contraction.

Slot Dimensions: for sizes 2" through 6" are 5/16" wide, 3/4" long.

Slot Dimensions: for 1" and 1 1/2" are 3/16" wide, 3/4" long.

Slot Spacing: 18" from center, beginning 6" from end.

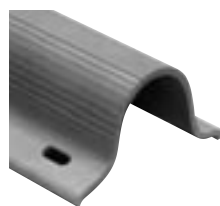

## Standard Duty

Part No.	Size	Std. Ctn. Qty.	Std. Ctn. Wt. (lbs.)	Dimensions				Actual Impact @ 0°C 20 Pound Top
				A	B	C	H	
59208N	1"	294	1059	0.100"	1 5/8"	2 3/8"	1 5/8"	40 Ft.-Lbs.
59211N	2"	136	726	0.100"	2 3/8"	4 1/2"	2 3/8"	100 Ft.-Lbs.
59211X (5' length)	2"	136	363	0.100"	2 3/8"	4 1/2"	2 3/8"	100 Ft.-Lbs.
59213N	3"	66	761	0.150"	3 1/2"	6"	3 1/2"	110 Ft.-Lbs.
59213X (5' length)	3"	66	381	0.150"	3 1/2"	6"	3 1/2"	100 Ft.-Lbs.
59215N	4"	65	910	0.150"	4 1/2"	6 1/2"	4 1/2"	110 Ft.-Lbs.
59216N	5"	30	515	0.150"	5 1/2"	7 1/2"	5 1/2"	110 Ft.-Lbs.

## Heavy Duty Schedule 40

59010N	1 1/2"	200	1142	0.145"	1 29/32"	3 1/2"	1 29/32"	100 Ft.-Lbs.
59011N	2"	136	1214	0.154"	2 3/8"	4 1/2"	2 3/8"	150 Ft.-Lbs.
59013N	3"	66	937	0.216"	3 1/2"	6"	3 9/32"	150 Ft.-Lbs.
59015N	4"	65	1621	0.237"	4 1/2"	6 1/2"	4 1/2"	260 Ft.-Lbs.
59015X (5' length)	4"	65	707	0.237"	4 1/2"	6 1/2"	4 1/2"	260 Ft.-Lbs.
59016N	5"	30	870	0.258"	5 1/2"	7 1/2"	5 1/2"	260 Ft.-Lbs.
59017N	6"	30	1160	0.280"	6 5/8"	8 3/4"	6 5/8"	260 Ft.-Lbs.

## Extra Heavy Duty Schedule 80

59411N	2"	136	1549	0.218"	2 3/8"	4 1/2"	2 3/8"	300 Ft.-Lbs.
59413N	3"	66	1495	0.030"	3 1/2"	6"	3 1/2"	525 Ft.-Lbs.

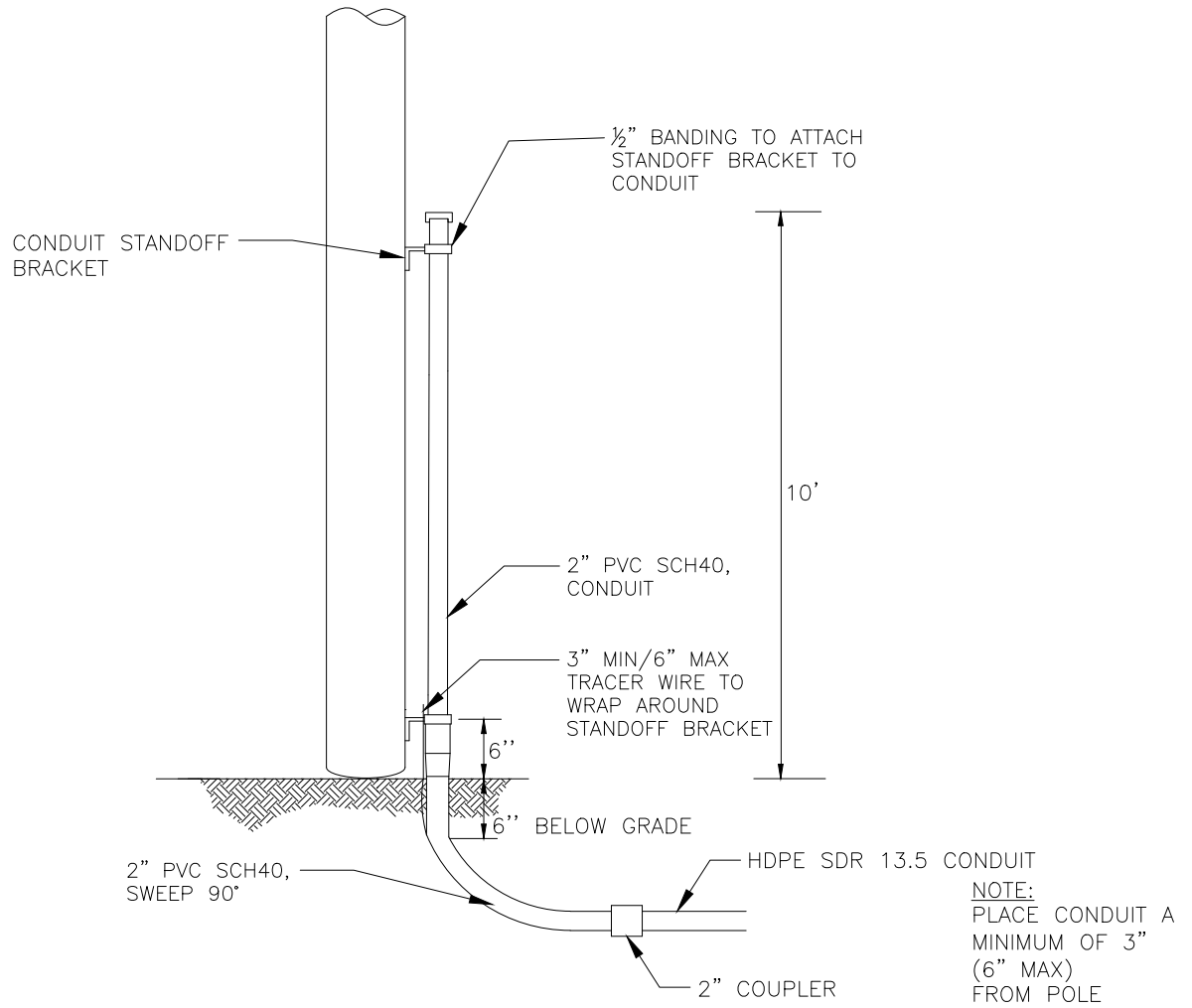

DESCRIPTION	QTY	MANUFACTURER (PREFERRED)	PART #
SCREW, LAG, 1/2" x 4-1/2"	10		
HDPE SDR 13.5 CONDUIT, VARIOUS SIZES	N/A		
2" PVC SCH40, RISER PIPE	1		
#12 TRACER WIRE	N/A		
2" PVC SCH40, SWEEP, 90 DEG	1		
CONDUIT STANDOFF BRACKET	VARIES		
CONDUIT STRAP KIT	VARIES		
2" COUPLER	1		



TYPICAL RISER  
CONDUIT  
WOOD POLE

(R2-W)

## CONCEPTUAL SIDE VIEW

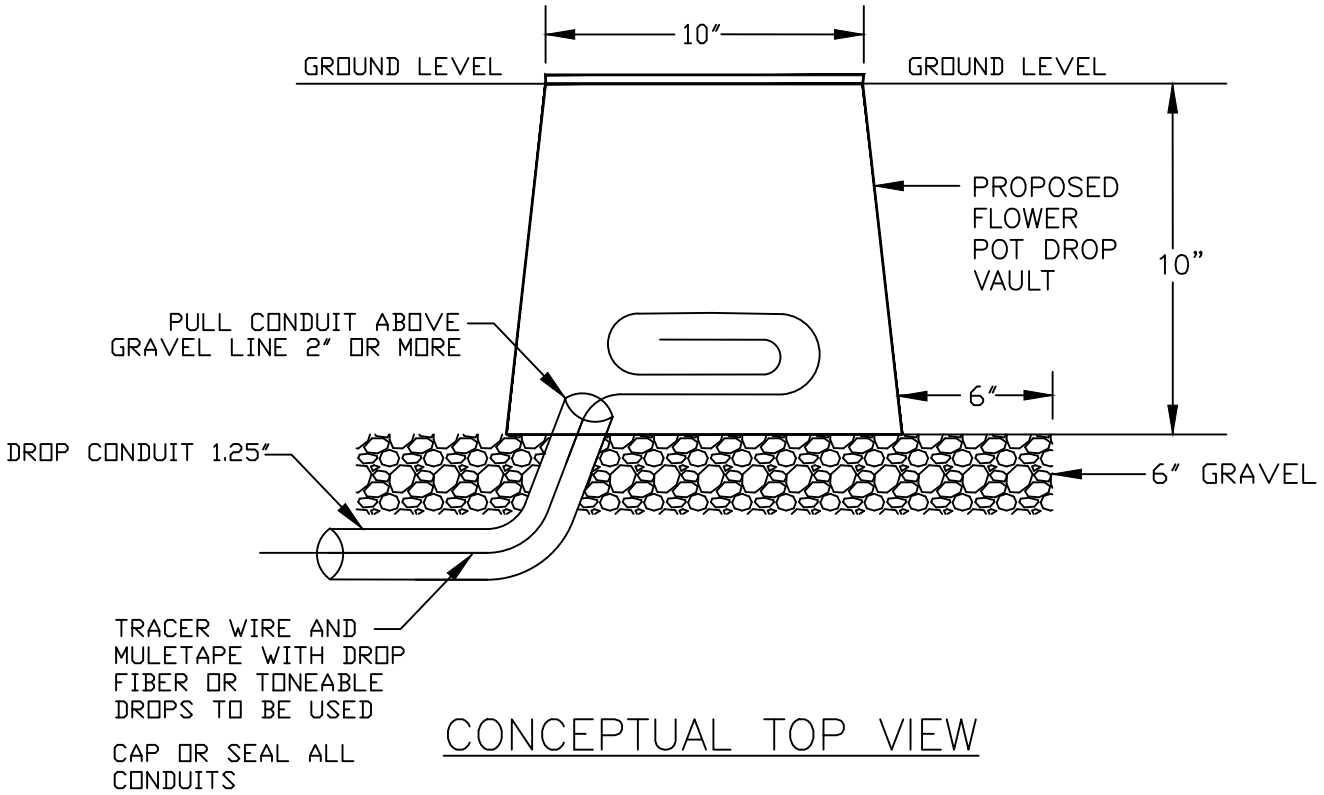

## CONCEPTUAL TOP VIEW

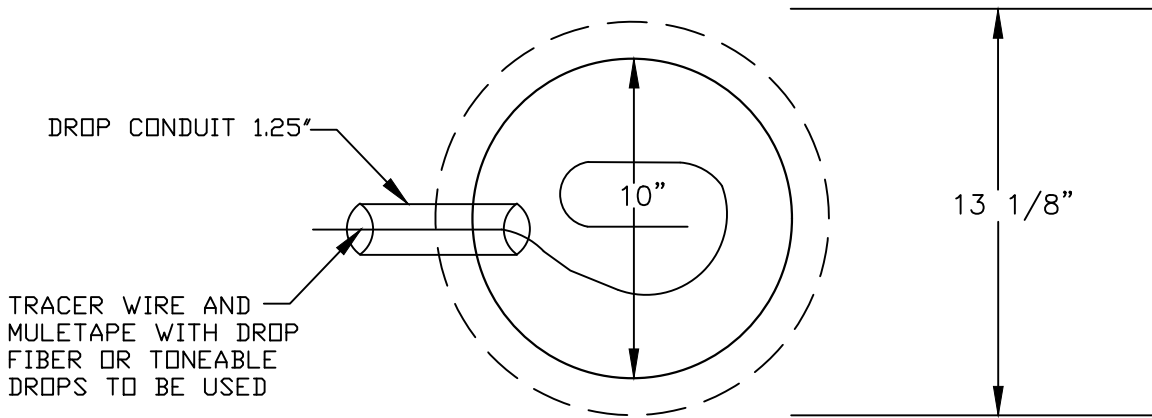

FLOWER POT

30"x48" PC UNIT, 2PC TIER 15/22  
 18", 24", and 36" HEIGHT



AMERICAN POLYMER COMPANY

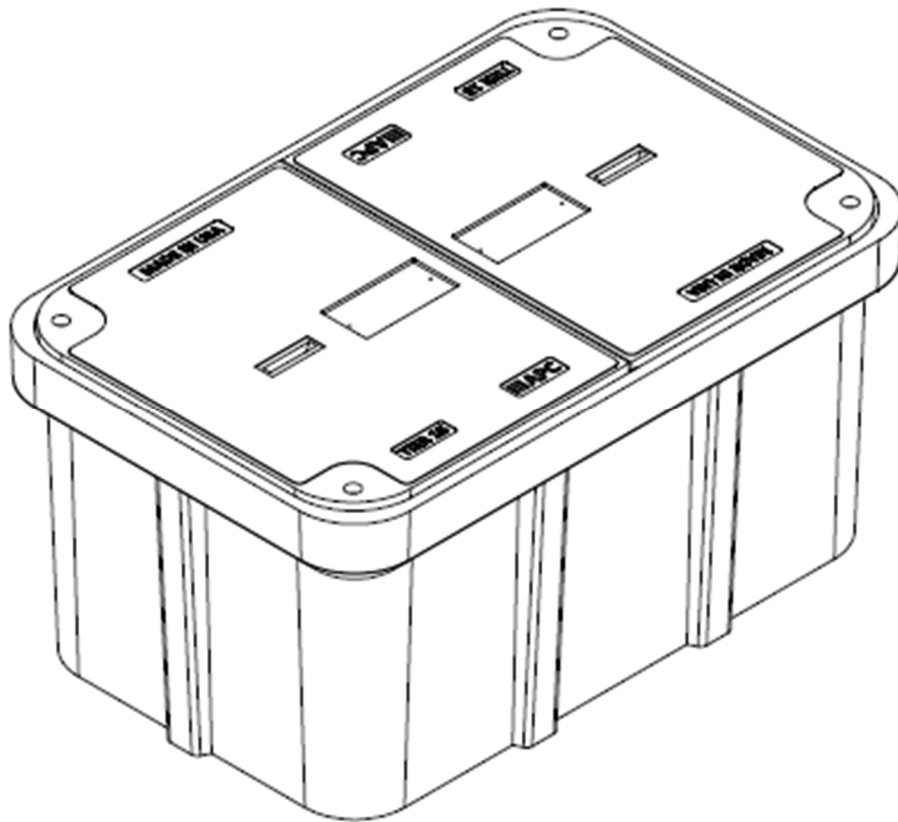

Description	Nominal Size	ANSI Tier	Part Number	Estimated Weight
PC Unit – TIER 15	30"x48"x18"	Tier 15	P304818HU15...	460 lbs.
PC Unit – TIER 22	30"x48"x18"	Tier 22	P304818HU22...	525 lbs.
PC Unit – TIER 15	30"x48"x24"	Tier 15	P304824HU15...	510 lbs.
PC Unit – TIER 22	30"x48"x24"	Tier 22	P304824HU22...	575 lbs.
PC Unit – TIER 15	30"x48"x36"	Tier 15	P304836HU15...	615 lbs.
PC Unit – TIER 22	30"x48"x36"	Tier 22	P304836HU22...	680 lbs.





# 30"x48" PC UNIT, 2PC TIER 15/22

18", 24", and 36" HEIGHT



AMERICAN POLYMER COMPANY

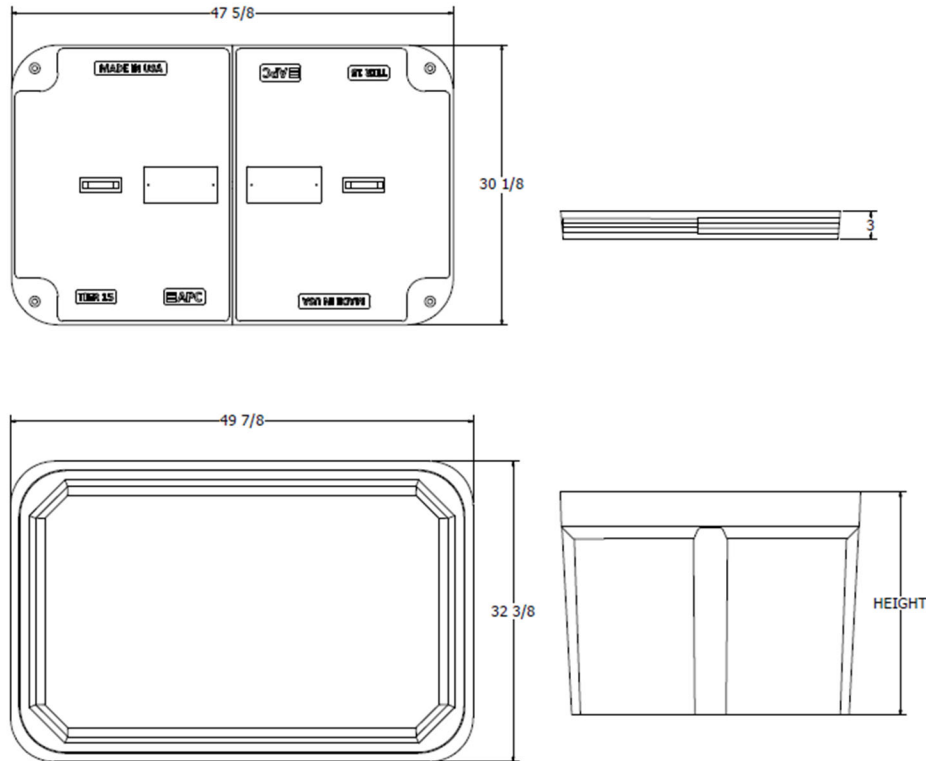

Components	Nominal Size	ANSI Tier	Part Number	Estimated Weight
Replacement Box	30"x48"x18"	Tier 22	P304818B22	185 lbs.
Replacement Box	30"x48"x24"	Tier 22	P304824B22	235 lbs.
Replacement Box	30"x48"x36"	Tier 22	P304836B22	340 lbs.
Replacement Lids - T15	30"x48" (half)	Tier 15	Various	150 lbs.
Replacement Lids - T22	30"x48" (half)	Tier 22	Various	170 lbs.

### Bolt options



Machine Thread



Auger Thread



24"x36" PC UNIT, TIER 15/22  
 18", 24", 30", and 36" HEIGHT



AMERICAN POLYMER COMPANY

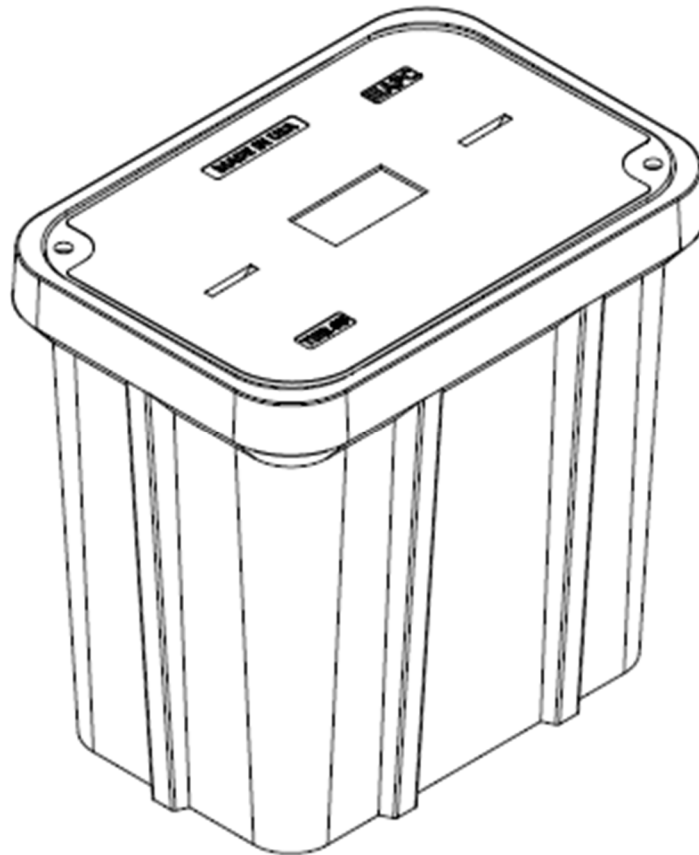

Description	Nominal Size	ANSI Tier	Part Number	Estimated Weight
PC Unit – TIER 15	24x36"x18"	Tier 15	P243618U15...	335 lbs.
PC Unit – TIER 22	24x36"x18"	Tier 22	P243618U22...	355 lbs.
PC Unit – TIER 15	24x36"x24"	Tier 15	P243624U15...	365 lbs.
PC Unit – TIER 22	24x36"x24"	Tier 22	P243624U22...	385 lbs.
PC Unit – TIER 15	24x36"x30"	Tier 15	P243630U15...	395 lbs.
PC Unit – TIER 22	24x36"x30"	Tier 22	P243630U22...	415 lbs.
PC Unit – TIER 15	24x36"x36"	Tier 15	P243636U15...	425 lbs.
PC Unit – TIER 22	24x36"x36"	Tier 22	P243636U22...	445 lbs.



# 24"x36" PC UNIT, TIER 15/22

18", 24", 30", and 36" HEIGHT



AMERICAN POLYMER COMPANY

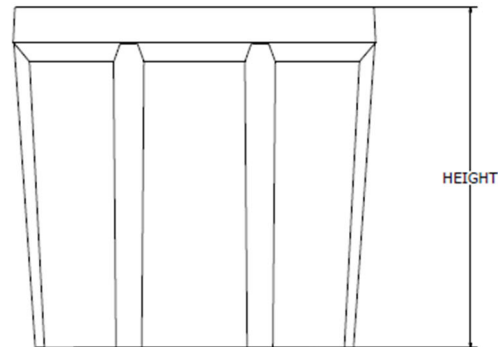
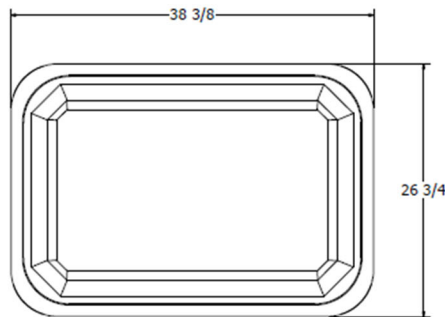
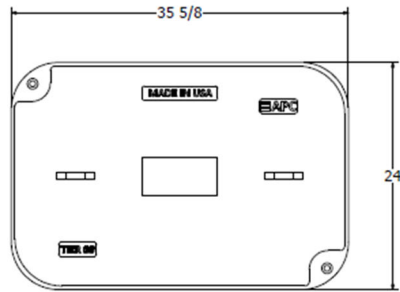

Components	Nominal Size	ANSI Tier	Part Number	Estimated Weight
Replacement Box	24"x36"x18"	Tier 22	P243618B22	165 lbs.
Replacement Box	24"x36"x24"	Tier 22	P243624B22	195 lbs.
Replacement Box	24"x36"x30"	Tier 22	P243630B22	225 lbs.
Replacement Box	24"x36"x36"	Tier 22	P243636B22	255 lbs.
Replacement Lids - T15	24"x36"	Tier 15	Various	170 lbs.
Replacement Lids - T22	24"x36"	Tier 22	Various	190 lbs.

### Bolt options

Hex Head



Machine Thread



Penta Head



Auger Thread



17"x30" PC UNIT, TIER 15/22

12", 18", 24", and 30" HEIGHT



AMERICAN POLYMER COMPANY

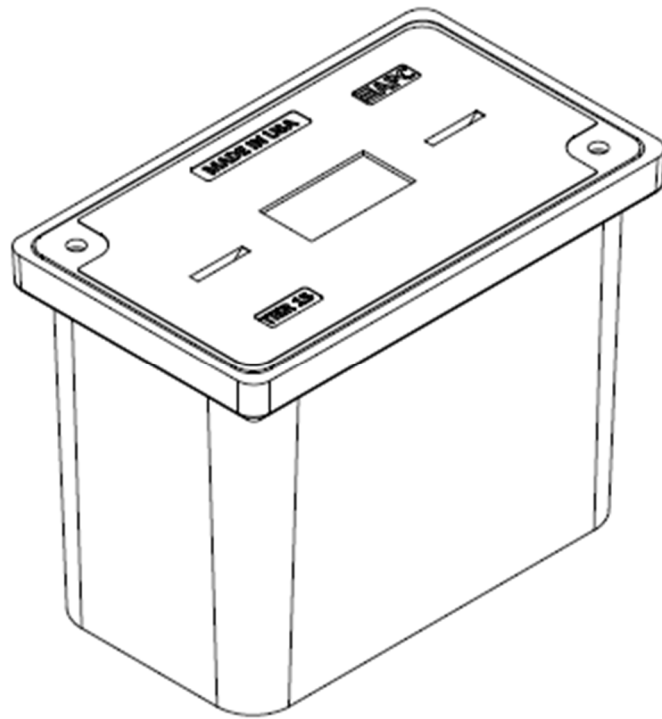

Description	Nominal Size	ANSI Tier	Part Number	Estimated Weight
PC Unit – TIER 15	17"x30"x12"	Tier 15	P173012U15...	138 lbs.
PC Unit – TIER 22	17"x30"x12"	Tier 22	P173012U22...	147 lbs.
PC Unit – TIER 15	17"x30"x18"	Tier 15	P173018U15...	172 lbs.
PC Unit – TIER 22	17"x30"x18"	Tier 22	P173018U22...	181 lbs.
PC Unit – TIER 15	17"x30"x24"	Tier 15	P173024U15...	192 lbs.
PC Unit – TIER 22	17"x30"x24"	Tier 22	P173024U22...	201 lbs.
PC Unit – TIER 15	17"x30"x30"	Tier 15	P173030U15...	217 lbs.
PC Unit – TIER 22	17"x30"x30"	Tier 22	P173030U22...	226 lbs.





# 17"x30" PC UNIT, TIER 15/22

12", 18", 24", and 30" HEIGHT



AMERICAN POLYMER COMPANY

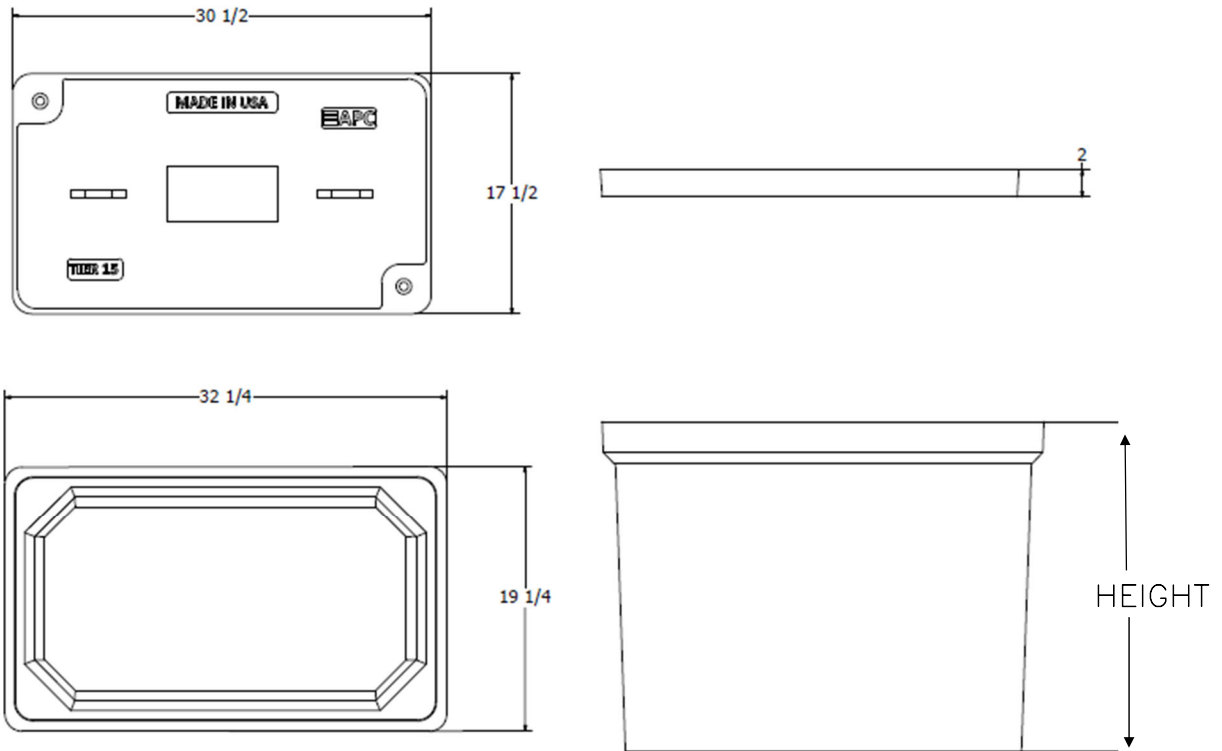

Components	Nominal Size	ANSI Tier	Part Number	Estimated Weight
Replacement Box	17"x30"x12"	Tier 22	P173012B22	66 lbs.
Replacement Box	17"x30"x18"	Tier 22	P173018B22	100 lbs.
Replacement Box	17"x30"x24"	Tier 22	P173024B22	120 lbs.
Replacement Box	17"x30"x30"	Tier 22	P173030B22	145 lbs.
Replacement Lids – T15	17"x30"	Tier 15	Various	72 lbs.
Replacement Lids – T22	17"x30"	Tier 22	Various	81 lbs.

### Bolt options



Machine Thread



Auger Thread



33"x60" PC UNIT, 2PC TIER 15/22  
36" HEIGHT



AMERICAN POLYMER COMPANY

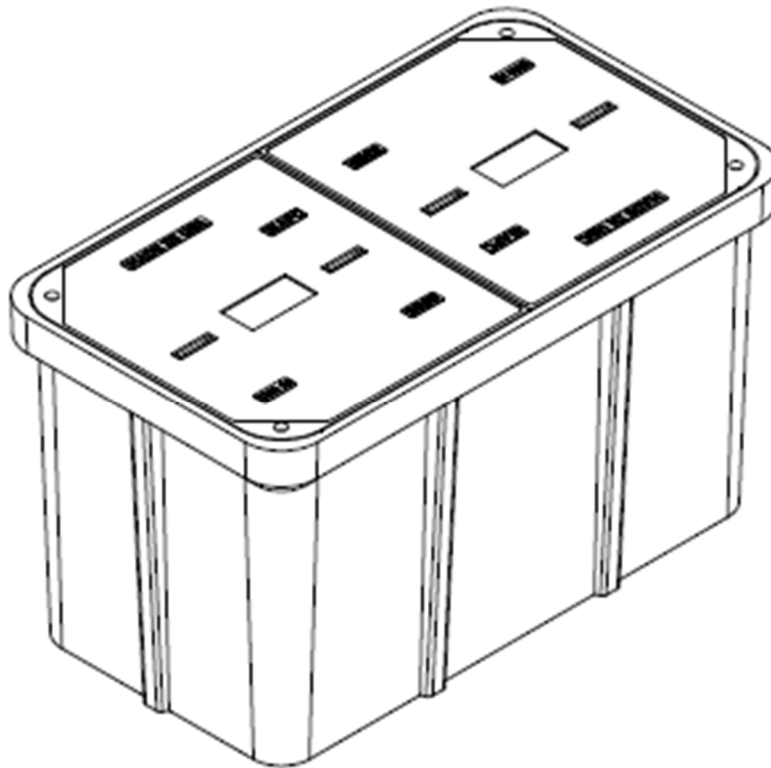

Description	Nominal Size	ANSI Tier	Part Number	Estimated Weight
PC Unit - TIER 15	33"x60"x36"	Tier 15	P336036U15...	930 lbs.
PC Unit - TIER 22	33"x60"x36"	Tier 22	P336036U22...	1030 lbs.



# 33"x60" PC UNIT, 2PC TIER 15/22

## 36" HEIGHT



AMERICAN POLYMER COMPANY

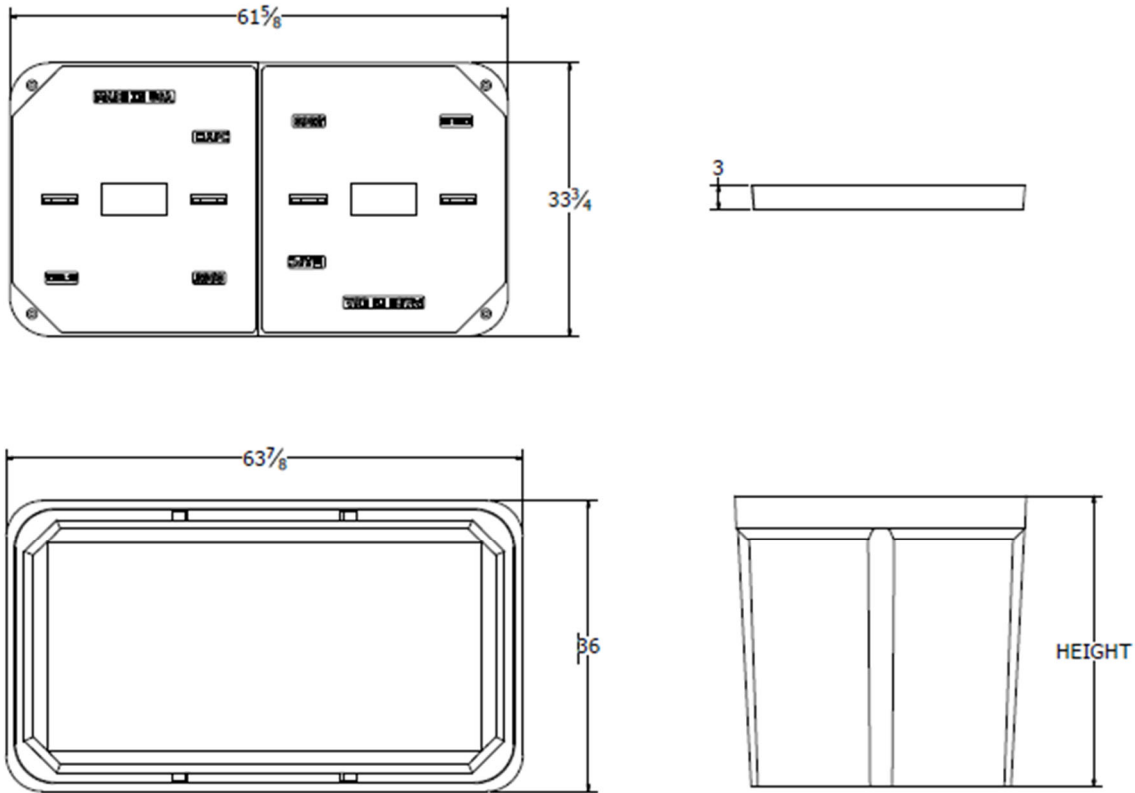

Components	Nominal Size	ANSI Tier	Part Number	Estimated Weight
Replacement Box	33"x60"x36"	Tier 22	P336036B22	530 lbs.
Replacement Lids - T15	33"x60" (half)	Tier 15	Various	200 lbs.
Replacement Lids - T22	33"x60" (half)	Tier 22	Various	250 lbs.

### Bolt options

Hex Head



Machine Thread



Penta Head



Auger Thread















# CITY OF BLOOMINGTON RIGHT-OF-WAY USE PERMIT APPLICATION

401 N Morton Street, Suite 130  
P.O. Box 100  
Bloomington, IN 47402

Phone: (812) 349-3913  
Fax: (812) 349-3520  
Email:  
engineering@bloomington.in.gov

ROW EXCAVATION  ROW USE

ADDRESS OF ROW ACTIVITY: S Maxwell St

<b>A. APPLICANT/AGENT INFORMATION:</b>		<b>D. TRAFFIC CONTROL DEVICES*:</b>	
APPLICANT NAME: <u>Bret Simons</u>		<input checked="" type="checkbox"/> CONES <input type="checkbox"/> ARROWBOARD	
E-MAIL: <u>bret.simons@aeg.cc</u>		<input type="checkbox"/> LIGHTED BARRELS <input checked="" type="checkbox"/> TYPE 3 BARRICADES	
COMPANY: <u>Atlantic Engineering Group</u>		<input checked="" type="checkbox"/> FLAGGERS <input type="checkbox"/> BPD OFFICER	
ADDRESS: <u>P.O. Box 349</u>		*PROVIDING MUTCD COMPLIANT TEMPORARY TRAFFIC CONTROL DEVICES AND MAINTENANCE OF TRAFFIC (MOT) PLAN IS YOUR RESPONSIBILITY AND REQUIRED. See page 3 for additional MOT resources; the graph paper can be used for your MOT site plan if needed or you can submit a separate sheet	
CITY, STATE, ZIP: <u>Buford, GA 30515</u>			
24-HR EMERGENCY CONTACT NAME: <u>(706)654-2298</u>		<b>E. METERED PARKING SPACES NEEDED: <input type="checkbox"/> Y <input type="checkbox"/> N</b>	
24-HR CONTACT PHONE #: _____		IT IS THE RESPONSIBILITY OF THE APPLICANT TO RESERVE PARKING METER(S) APPLICATION LOCATED: <a href="https://bloomington.in.gov/transportation/parking/moving">https://bloomington.in.gov/transportation/parking/moving</a> OR CONTACT PARKING SERVICES WITH QUESTIONS AT (812)349-3436	
INSURANCE #*: <u>TB5-691-473497-082</u> COMPANY: <u>ACORD</u>		<b>F. IS THIS A <input type="checkbox"/> CBU* <input type="checkbox"/> COUNTY* <input type="checkbox"/> IU* <input type="checkbox"/> NP* PROJECT?</b>	
BOND #*: <u>1160465</u> COMPANY: <u>LEXON</u>		PROJECT NAME: <u>BLC02a-F14 S Maxwell St</u>	
*INSURANCE & BOND MUST BE ON FILE WITH THE CITY BEFORE PERMIT WILL BE ISSUED		PROJECT #: <u>BLC02a-F14 S Maxwell St</u>	
<b>**SUBCONTRACTOR INFORMATION**</b>		PROJECT MGR.: <u>Lex Mullins</u>	
(LIST ALL COMPANIES WORKING UNDER PRIMARY CONTRACTOR PERMIT)		PROJECT MGR. #: <u>215-847-8819</u>	
COMPANY NAME: _____		*CBU = CITY OF BLOOMINGTON UTILITIES *COUNTY = MONROE COUNTY	
<b>B. WORK DESCRIPTION:</b>		*IU = INDIANA UNIVERSITY *NP = NOT-FOR-PROFIT AGENCY	
<input type="checkbox"/> POD/DUMPSTER <input type="checkbox"/> CRANE <input type="checkbox"/> SCAFFOLDING <input checked="" type="checkbox"/> CONSTRUCTION USE*		<b>G. EXCAVATIONS:</b>	
(EXPLAIN): <u>Excavation</u>		SQ FT OF PAVEMENT* EXCAVATIONS: <u>N/A</u>	
*EXCAVATION, LONG TERM USE FOR STORAGE OF MATERIAL/EQUIPMENT/WALKAROUND		*PAVEMENT INCLUDES: IN OR UNDER CONCRETE, OR ASPHALT INCLUDING CURBS	
<b>C. RIGHT OF WAY TO BE USED/CLOSED:</b>		SQ FT OF NON-PAVEMENT* EXCAVATIONS: <u>490.56 Sq Ft</u>	
STREET NAME 1: <u>S Maxwell St</u>		*DIRT, GRASS, GRAVEL, LANDSCAPE AREA OR OTHER UNPAVED SURFACE	
1ST INTERSECTING STREET NAME: _____		LINEAL FT OF BORE*: <u>19,558 Lineal Feet</u>	
2ND INTERSECTING STREET NAME: _____		*BORE PITS SHALL BE CALCULATED AS SQ FT EXCAVATIONS	
<input type="checkbox"/> ROAD CLOSURE <input checked="" type="checkbox"/> LANE CLOSURE 1 <input checked="" type="checkbox"/> 2 <input type="checkbox"/> 3 <input type="checkbox"/>		# OF POLE INSTALLATIONS/REMOVAL: <u>N/A</u>	
<input checked="" type="checkbox"/> SIDEWALK* <input type="checkbox"/> BIKE LANE <input type="checkbox"/> OTHER		SQ FT OF SIDEWALK RECONSTRUCTION*: <u>N/A</u>	
TRANSIT STOP? <input type="checkbox"/> Y <input type="checkbox"/> N PARKING LANE(S)** <input type="checkbox"/> Y <input type="checkbox"/> N **NON-METERED		*CONCRETE OR ASPHALT SIDEWALK/PATH BEING IMPROVED/REPLACED	
START DATE: <u>Feb 3rd</u> END DATE: _____ # OF DAYS*: <u>30</u>		SQ FT OF SIDEWALK NEW CONSTRUCTION*: <u>N/A</u>	
STREET NAME 2: _____		*CONCRETE OR ASPHALT SIDEWALK/PATH THAT IS NEW INFRASTRUCTURE	
1ST INTERSECTING STREET NAME: _____		#RESIDENTIAL DRIVEWAY INSTALLATION: <u>N/A</u>	
2ND INTERSECTING STREET NAME: _____		 <p>TO SUBMIT A LOCATE REQUEST 24 HRS A DAY, 7 DAYS A WEEK CALL 811 OR 800-382-5544 CALL 2 WORKING DAYS BEFORE YOU DIG. IT'S THE LAW.</p>	
<input type="checkbox"/> ROAD CLOSURE <input type="checkbox"/> LANE CLOSURE 1 <input type="checkbox"/> 2 <input type="checkbox"/> 3 <input type="checkbox"/>			
<input type="checkbox"/> SIDEWALK* <input type="checkbox"/> BIKE LANE <input type="checkbox"/> OTHER		<b>H. INDEMNIFICATION AGREEMENT:</b>	
TRANSIT STOP? <input type="checkbox"/> Y <input type="checkbox"/> N PARKING LANE(S)** <input type="checkbox"/> Y <input type="checkbox"/> N **NON-METERED		The petitioner/applicant hereby agrees to hold harmless, defend and to indemnify the City of Bloomington from or against all claims, action, damages and expenses, including but not limited to reasonable attorney's fees or any alleged injury and/or death to any person or damage to any property arising, or alleged to have arisen out of any act of commission or omission on the part of the petitioner/applicant, his/her heirs, successors, or assigns regardless of whether such acts are the direct or indirect result of the public right-of-way use pursuant to this permit grant.	
START DATE: _____ END DATE: _____ # OF DAYS*: _____		I AFFIRM, UNDER THE PENALTIES FOR PERJURY, THAT THE FOREGOING REPRESENTATIONS ARE TRUE.	
*SIDEWALK CLOSURES FOR A PERIOD OR PERIODS TOTALING 24HRS OR MORE SHALL INSTALL A WALKAROUND UNLESS OTHERWISE APPROVED DURING REVIEW		PRINT NAME: <u>Bret Simons</u>	
<b>STANDARD CLOSURE HOURS MON-FRI*: 9:00 AM - 3:00 PM &amp; 6:00 PM - 9:00 PM</b>		SIGNATURE: <u>Bret Simons</u>	
STANDARD CLOSURE HOURS <input checked="" type="checkbox"/> *NON-STANDARD CLOSURE HOURS <input type="checkbox"/>		DATE: <u>1/18/2023</u>	
REQUESTED CLOSURE HOURS: _____ AM - _____ PM			
*non-standard hours may not be allowed near schools, on arterials, or other circumstances and are subject to approval during the permitting process			
BMC 14.09.040 allows work from 6 AM to 10 PM without violating the noise ordinance (7AM to 9PM for pneumatic hammers)			

For Administration Use Only (applicable to CLOSURE approval)

Approved By: \_\_\_\_\_  BPW  City Engineer  Director Date: \_\_\_\_\_

Staff Representative: \_\_\_\_\_ Phone#: \_\_\_\_\_ Date: \_\_\_\_\_



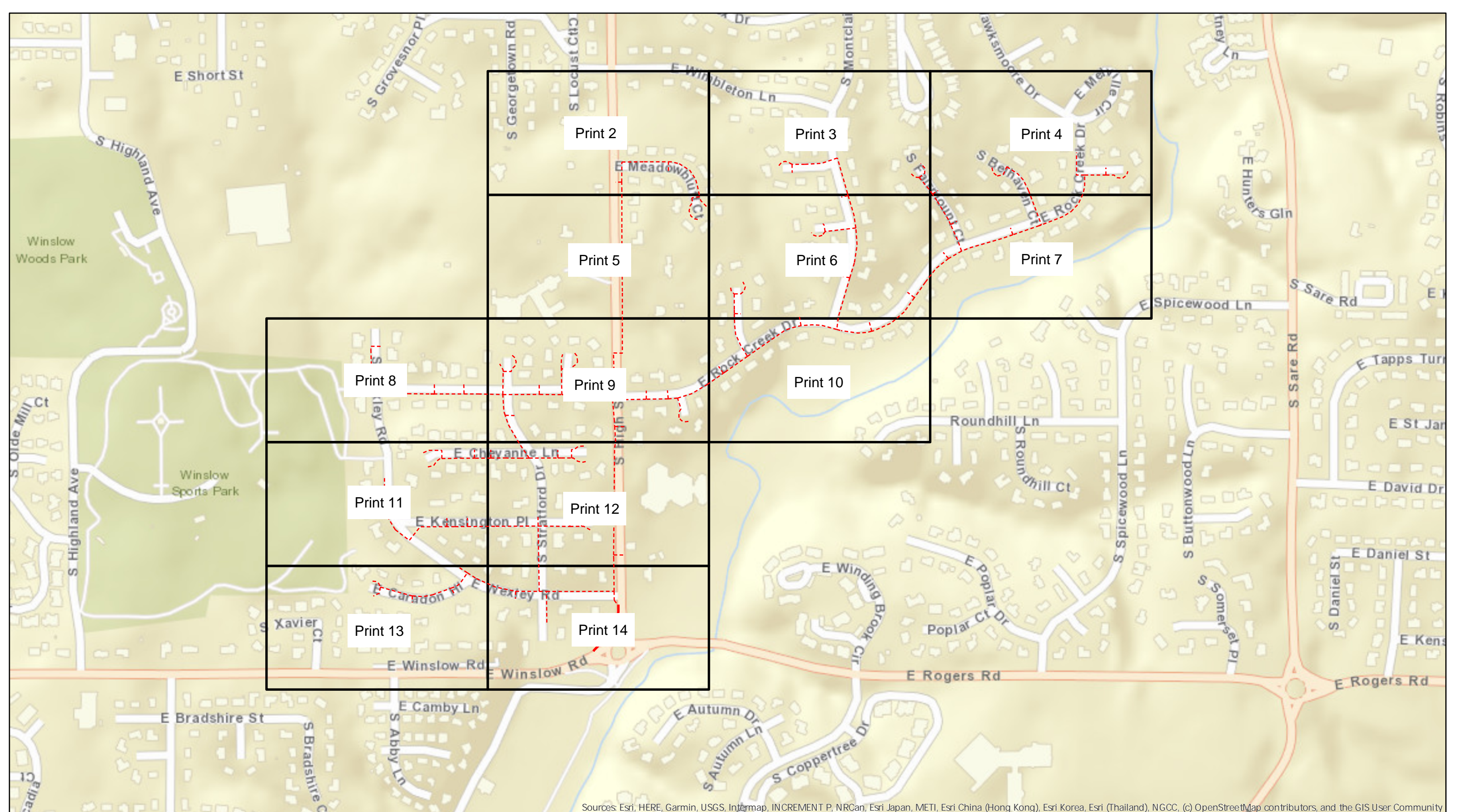

Sources: Esri, HERE, Garmin, USGS, Intermap, INCREMENT P, NRCan, Esri Japan, METI, Esri China (Hong Kong), Esri Korea, Esri (Thailand), NGCC, (c) OpenStreetMap contributors, and the GIS User Community



Legend BLC02a-F12\_S High St

- Overhead Strand
- - - Conduit
- Grids

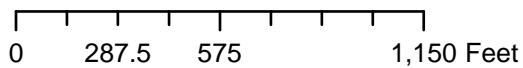

City of Bloomington, IN Permit:  
Design View

INI	BY	DATE	DESCRIPTION





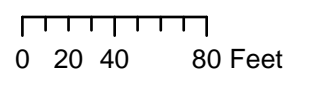
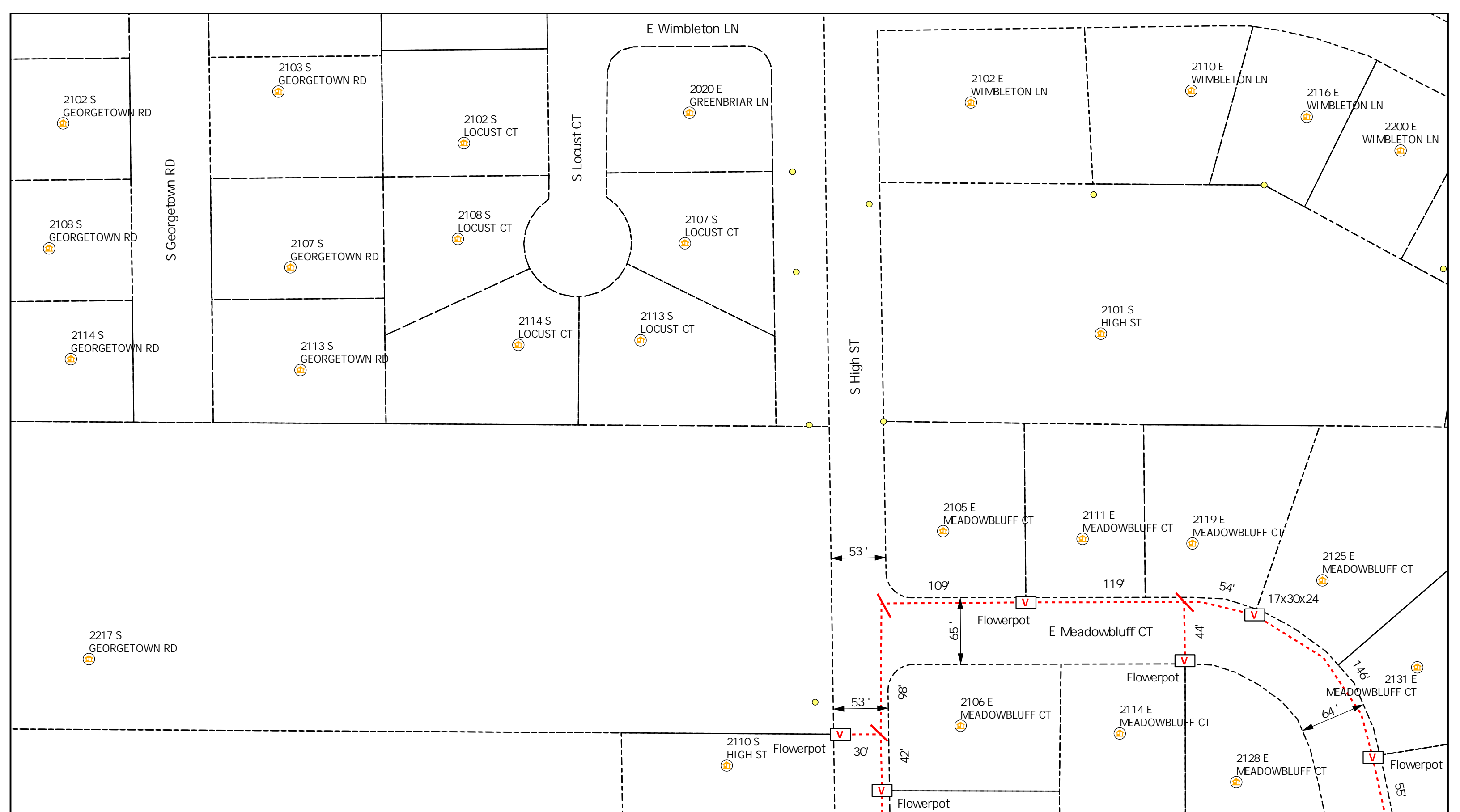

**Legend**

- Poles
- Vaults
- Overhead Strand
- Conduit
- Bloomington\_Parcels
- Risers
- Address
- Anchor
- Sidewalk
- Grids

All Flowerpots 12" DIA



City of Bloomington, IN Permit:  
Design View

INI	BY	DATE	DESCRIPTION





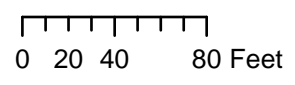
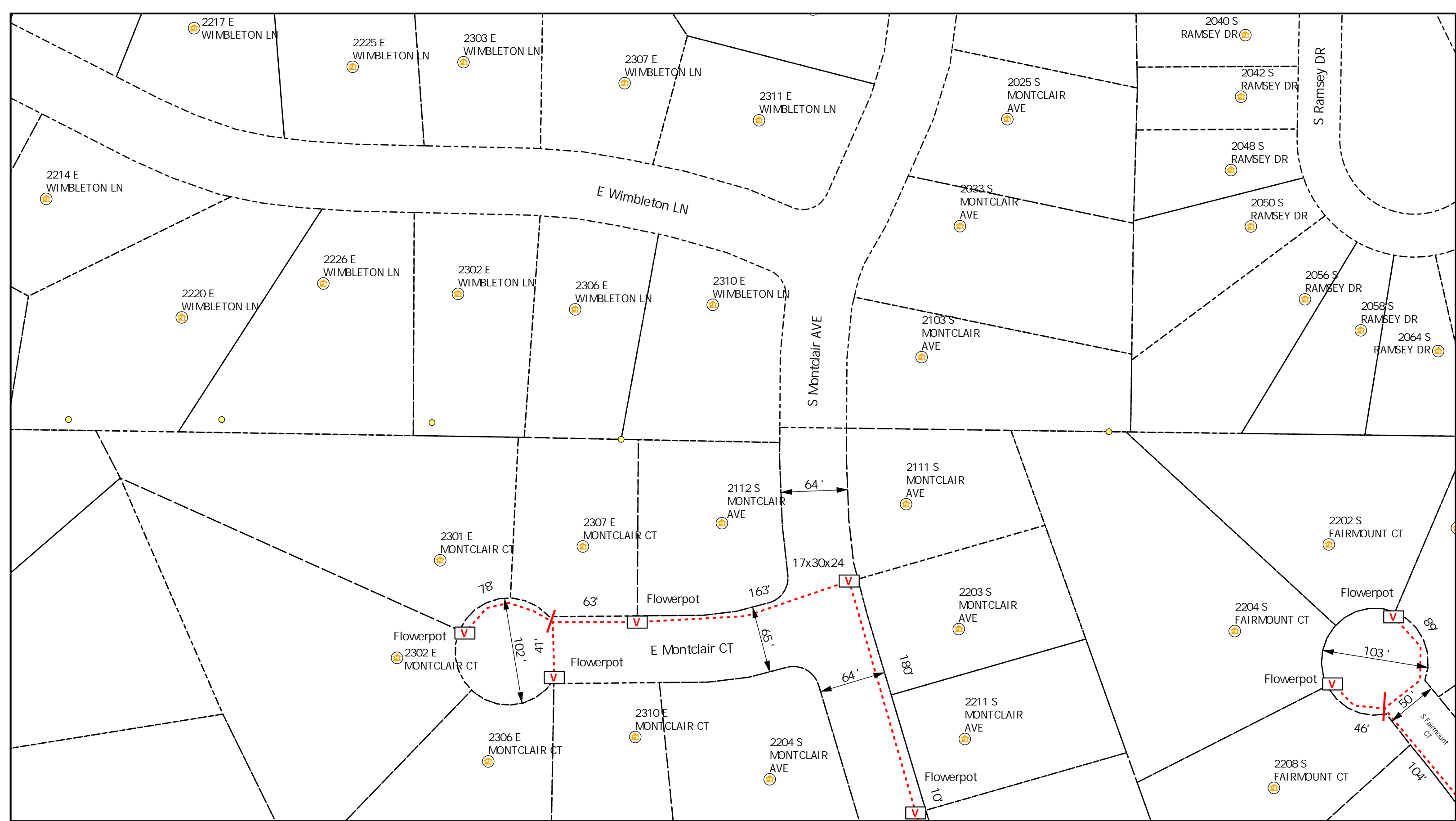

**Legend**

- Poles
- V Vaults
- Overhead Strand
- Conduit
- Bloomington\_Parcels
- R Risers
- Ⓜ Address
- Y Anchor
- ← Sidewalk
- Grids

All Flowerpots 12" DIA



City of Bloomington, IN Permit:  
Design View

INI	BY	DATE	DESCRIPTION



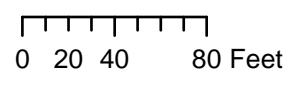
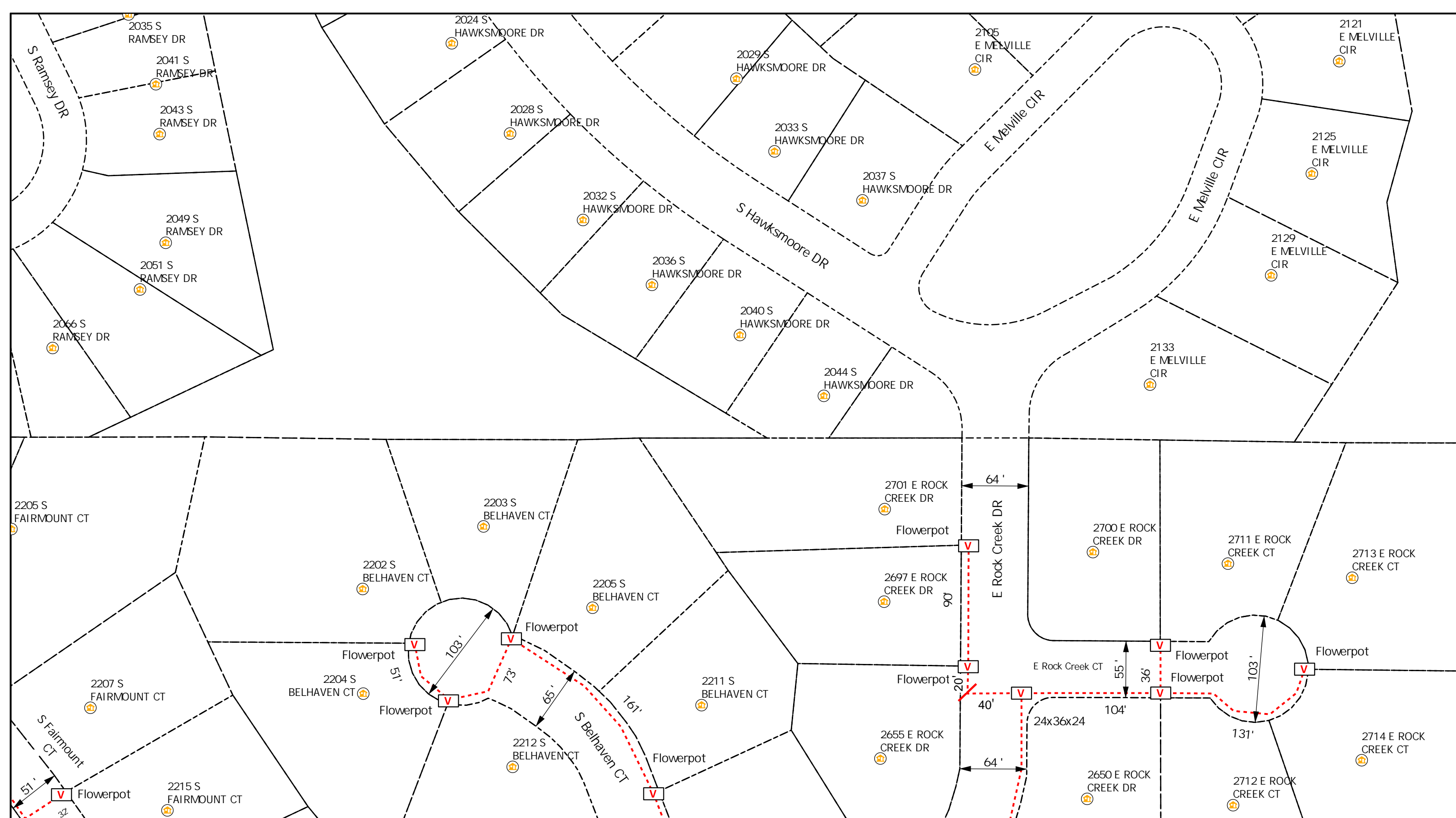

**Legend**

- Poles
- V Vaults
- Overhead Strand
- - - Conduit
- Bloomington\_Parcels
- R Risers
- Ⓜ Address
- Y Anchor
- ← Sidewalk
- Grids

All Flowerpots 12" DIA



City of Bloomington, IN Permit:  
Design View

INI	BY	DATE	DESCRIPTION



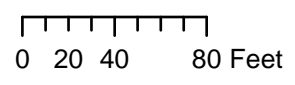
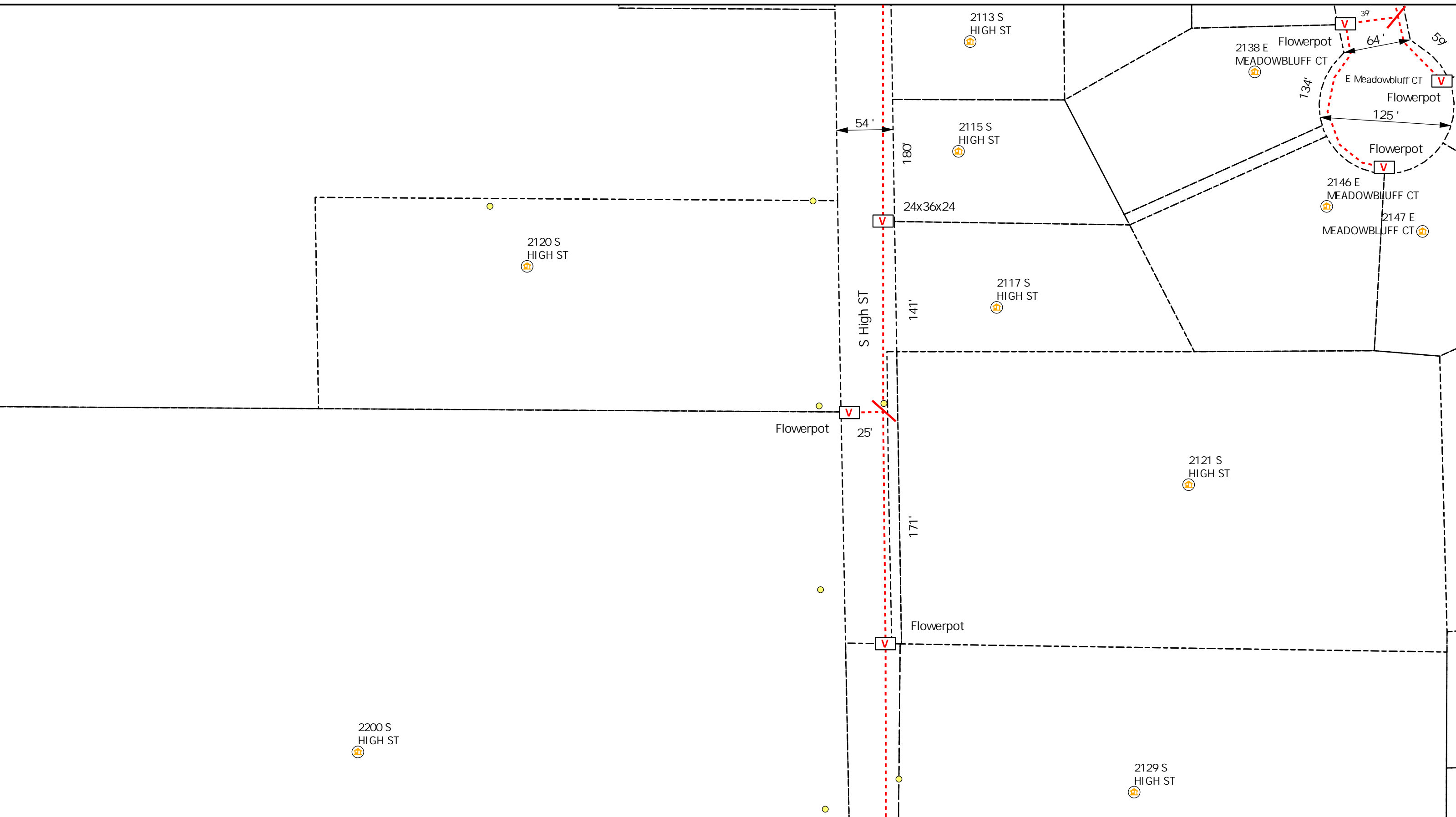

**Legend**

- Poles
- V Vaults
- Overhead Strand
- Conduit
- Bloomington\_Parcels
- R Risers
- A Address
- Y Anchor
- ← Sidewalk
- Grids

All Flowerpots 12" DIA



City of Bloomington, IN Permit:  
Design View

INI	BY	DATE	DESCRIPTION



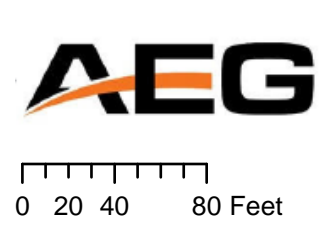
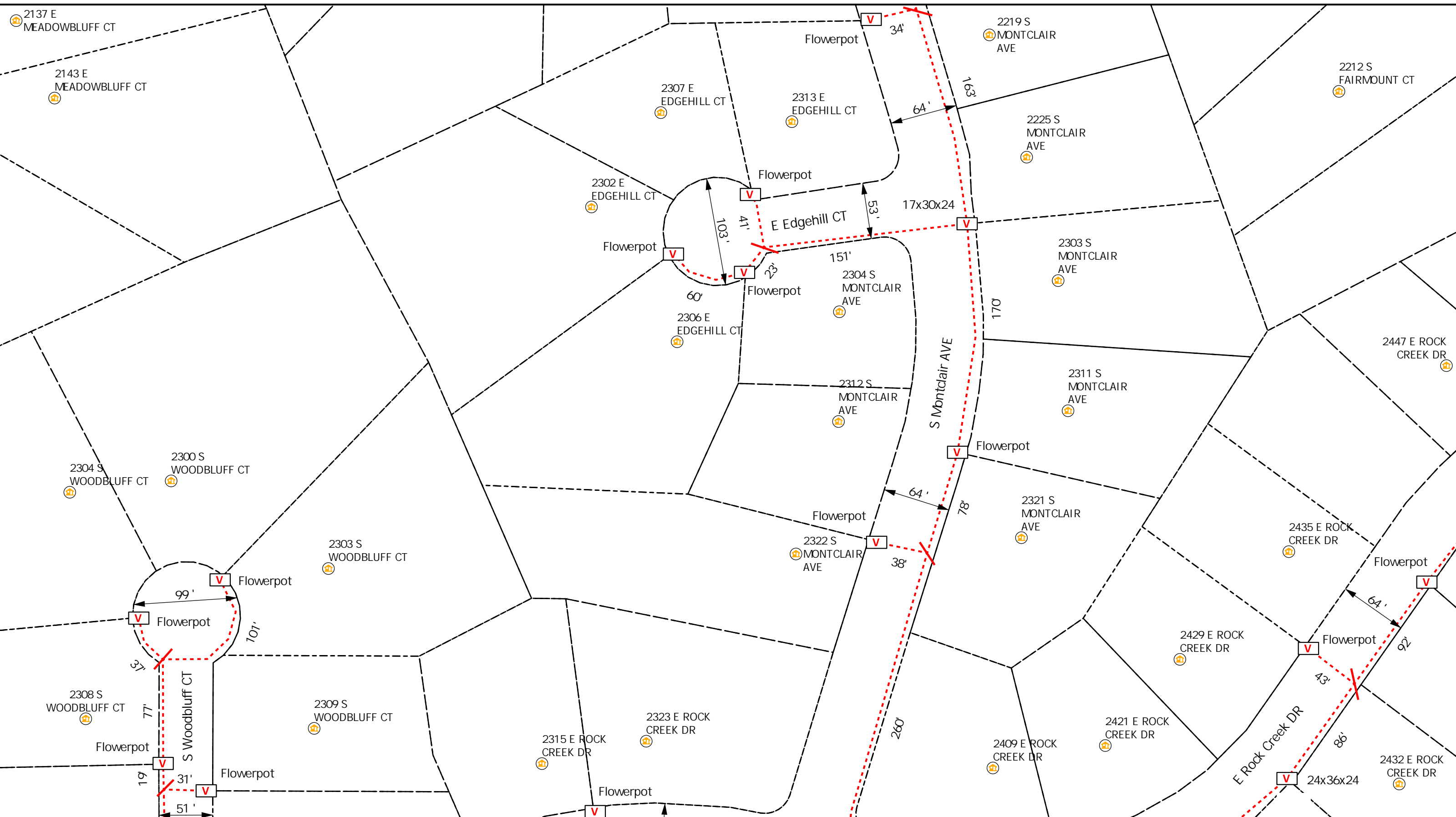

**Legend**

- Poles
- Vaults
- Overhead Strand
- Conduit
- Bloomington\_Parcels
- Risers
- Address
- Anchor
- Sidewalk
- Grids

All Flowerpots 12" DIA



City of Bloomington, IN Permit:  
Design View

INI	BY	DATE	DESCRIPTION





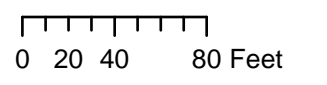
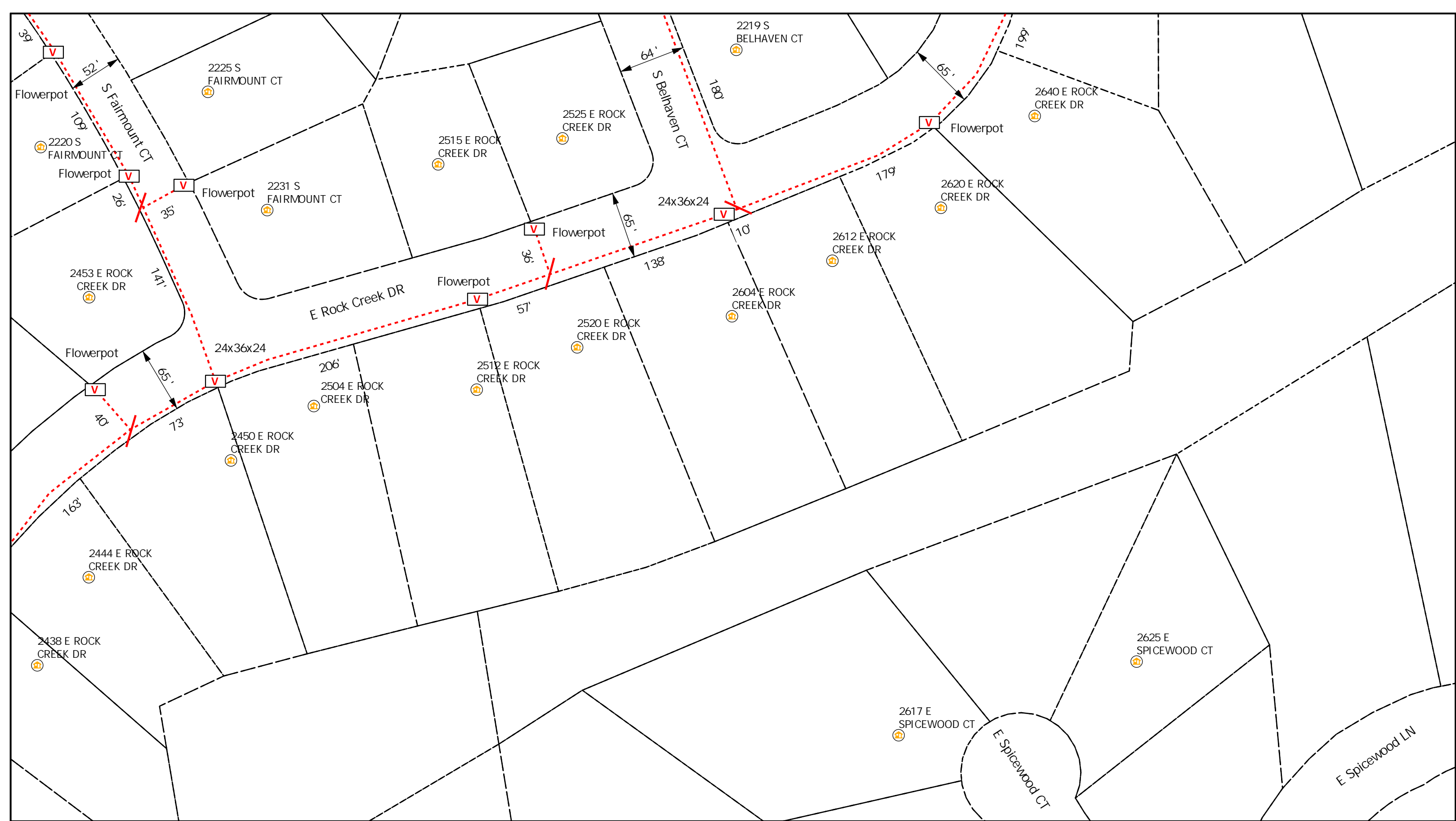

**Legend**

- Poles
- Vaults
- Overhead Strand
- Conduit
- Bloomington\_Parcels
- Risers
- Address
- Anchor
- Sidewalk
- Grids

All Flowerpots 12" DIA



City of Bloomington, IN Permit:  
Design View

INI	BY	DATE	DESCRIPTION



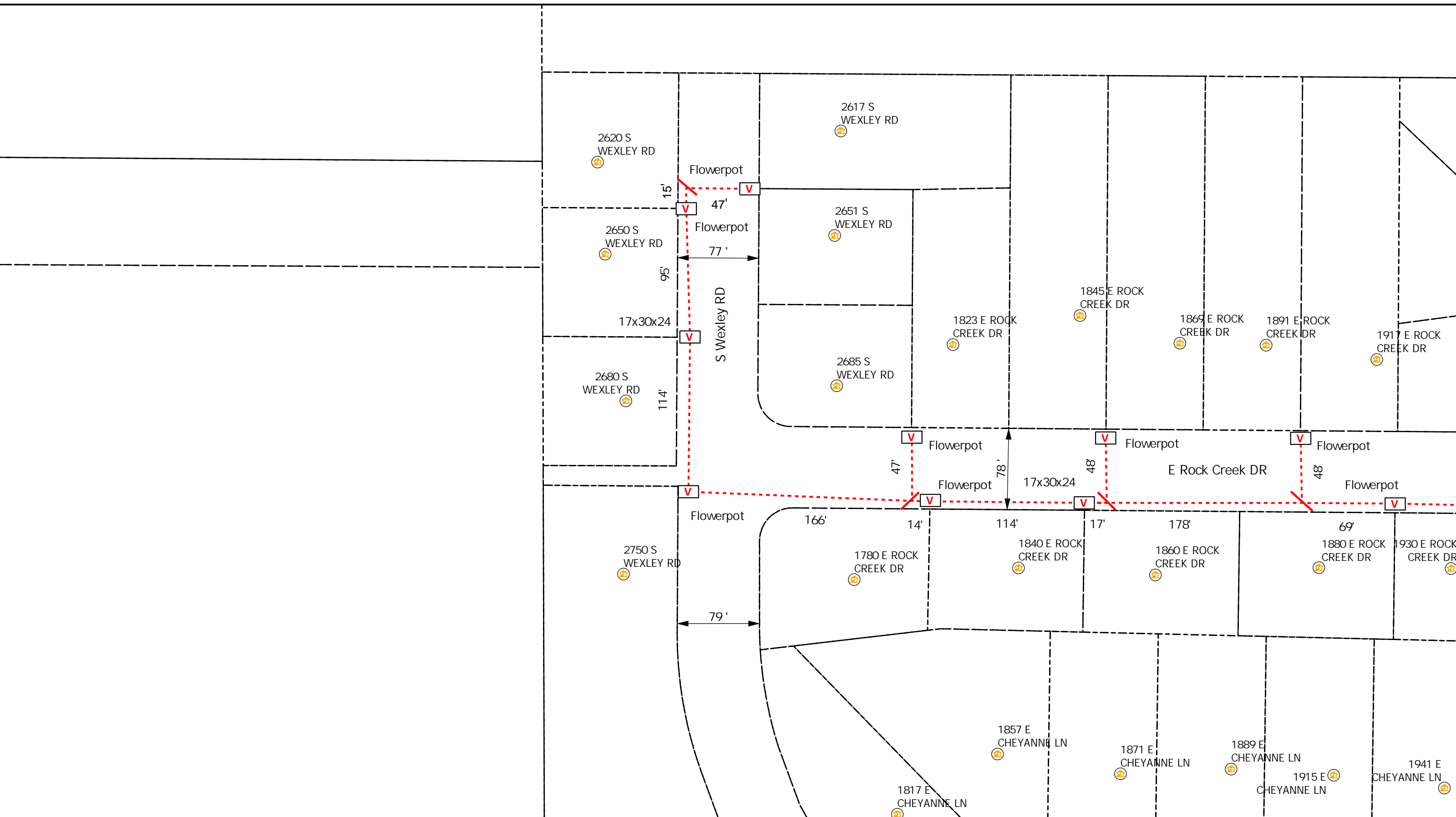

**AEG**

0 20 40 80 Feet

**Legend**

- Poles
- Vaults
- Overhead Strand
- Conduit
- Bloomington\_Parcels
- Risers
- Address
- Anchor
- Sidewalk
- Grids

All Flowerpots 12" DIA

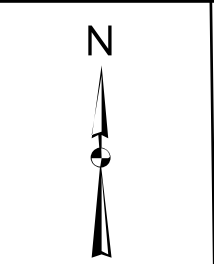

City of Bloomington, IN Permit:  
Design View

INI	BY	DATE	DESCRIPTION

Print 8 of 14



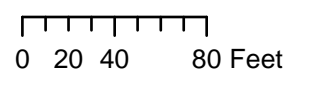
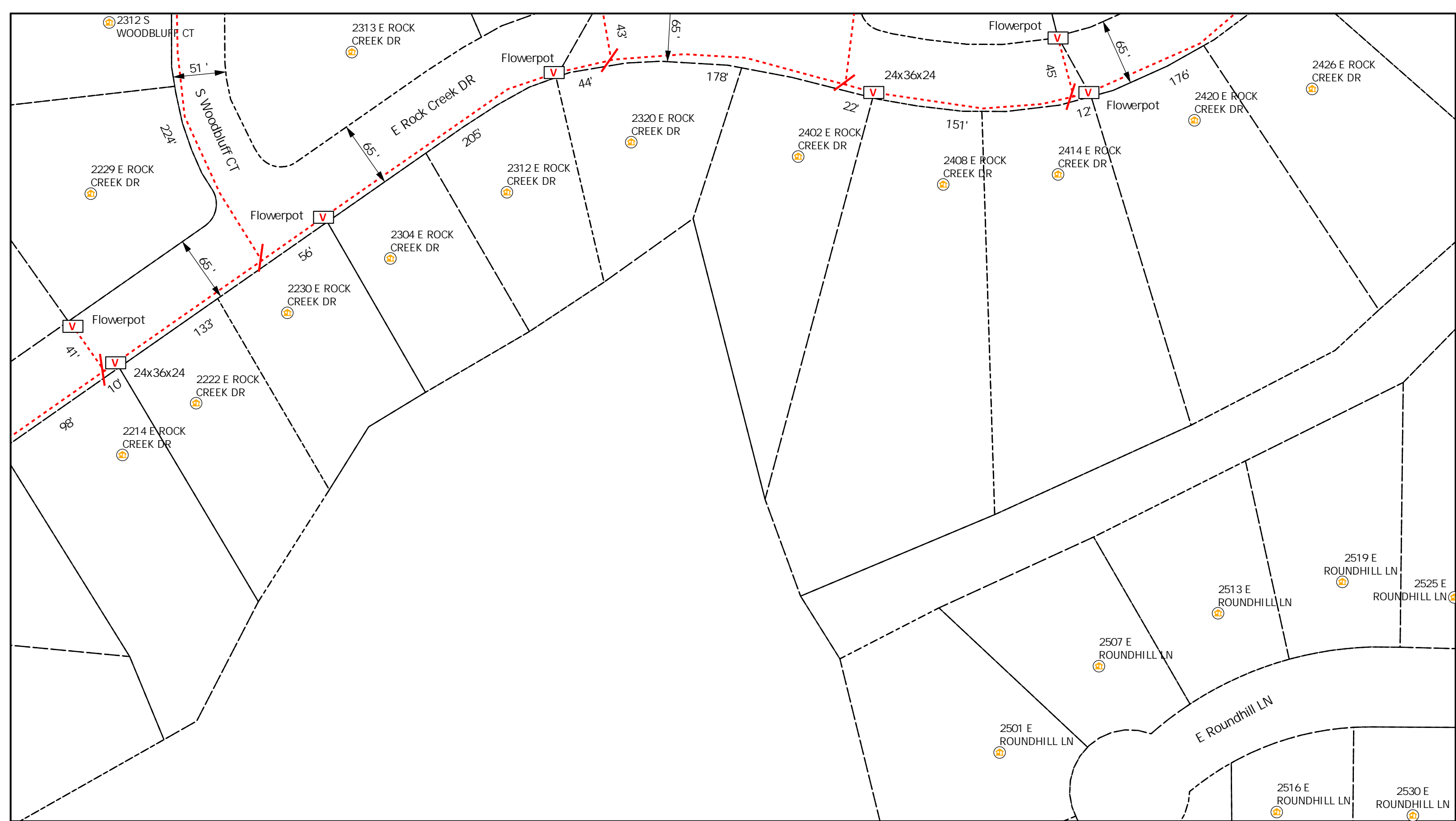

**Legend**

- Poles
- Vaults
- Overhead Strand
- Conduit
- Bloomington\_Parcels
- Risers
- Address
- Anchor
- Sidewalk
- Grids

All Flowerpots 12" DIA



City of Bloomington, IN Permit:  
Design View

INI	BY	DATE	DESCRIPTION





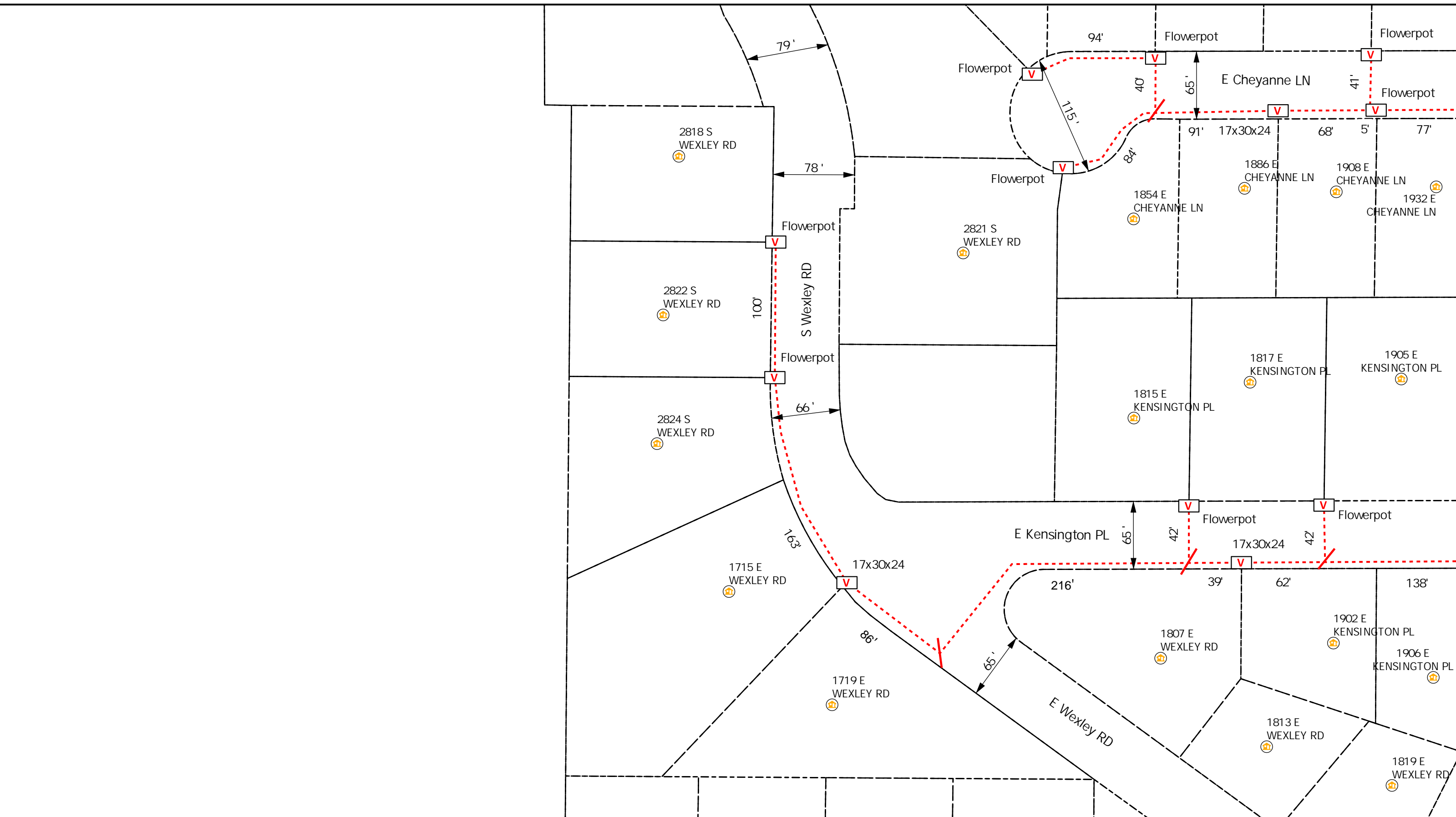

**AEG**

0 20 40 80 Feet

**Legend**

- Poles
- Ⓜ Bloomington\_Parcels
- Ⓜ Risers
- Ⓜ Address
- Ⓜ Grids
- Ⓜ Vaults
- Overhead Strand
- - - Conduit
- Ⓜ Anchor
- Ⓜ Sidewalk

All Flowerpots 12" DIA

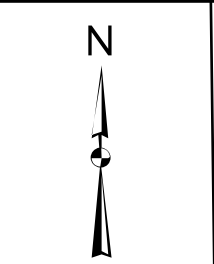

City of Bloomington, IN Permit:  
Design View

INI	BY	DATE	DESCRIPTION

Print 11 of 14

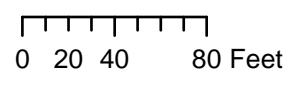
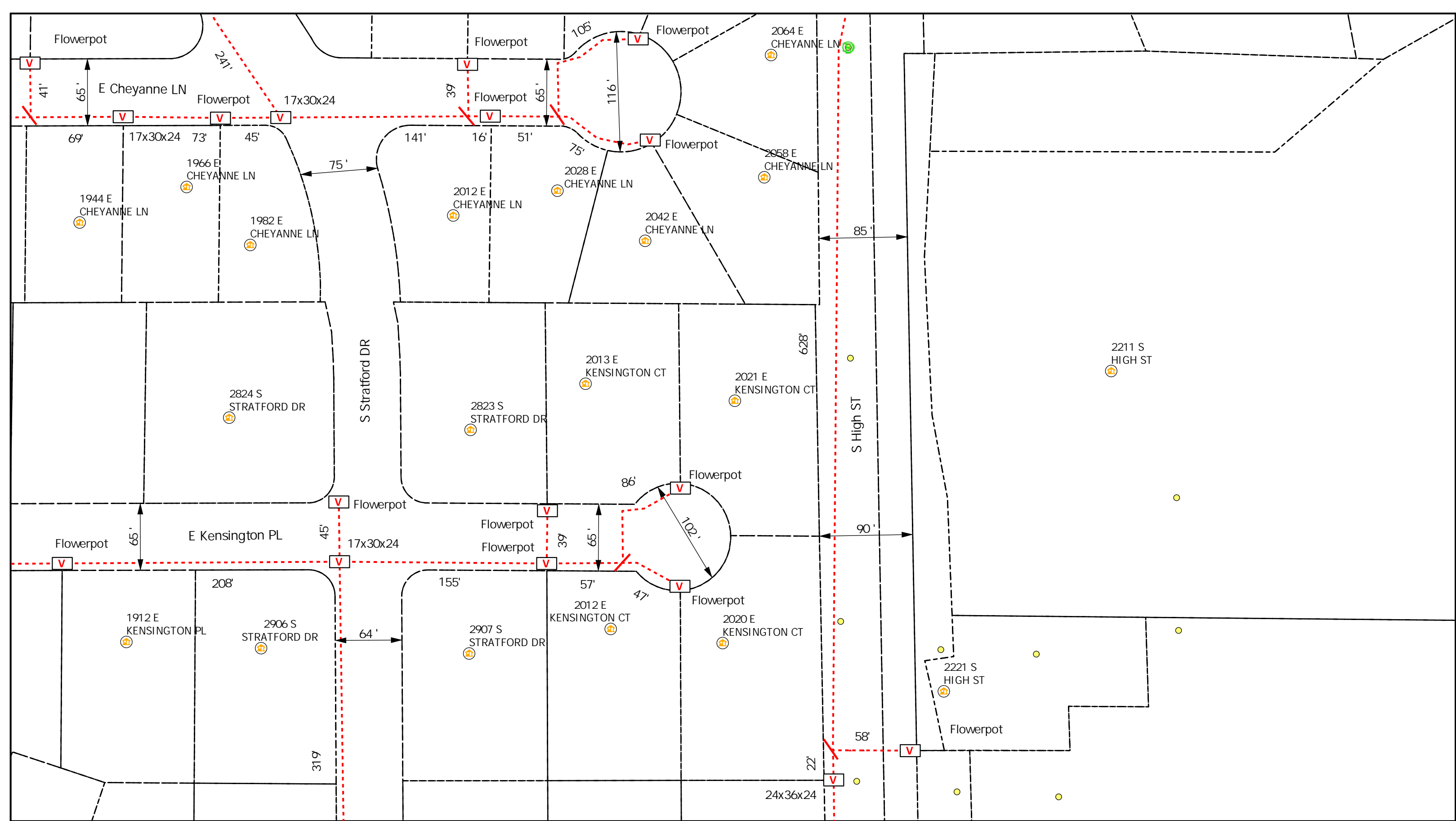

**Legend**

- Poles
- Vaults
- Overhead Strand
- Conduit
- Bloomington\_Parcels
- Risers
- Address
- Anchor
- Sidewalk
- Grids

All Flowerpots 12" DIA



City of Bloomington, IN Permit:  
Design View

INI	BY	DATE	DESCRIPTION



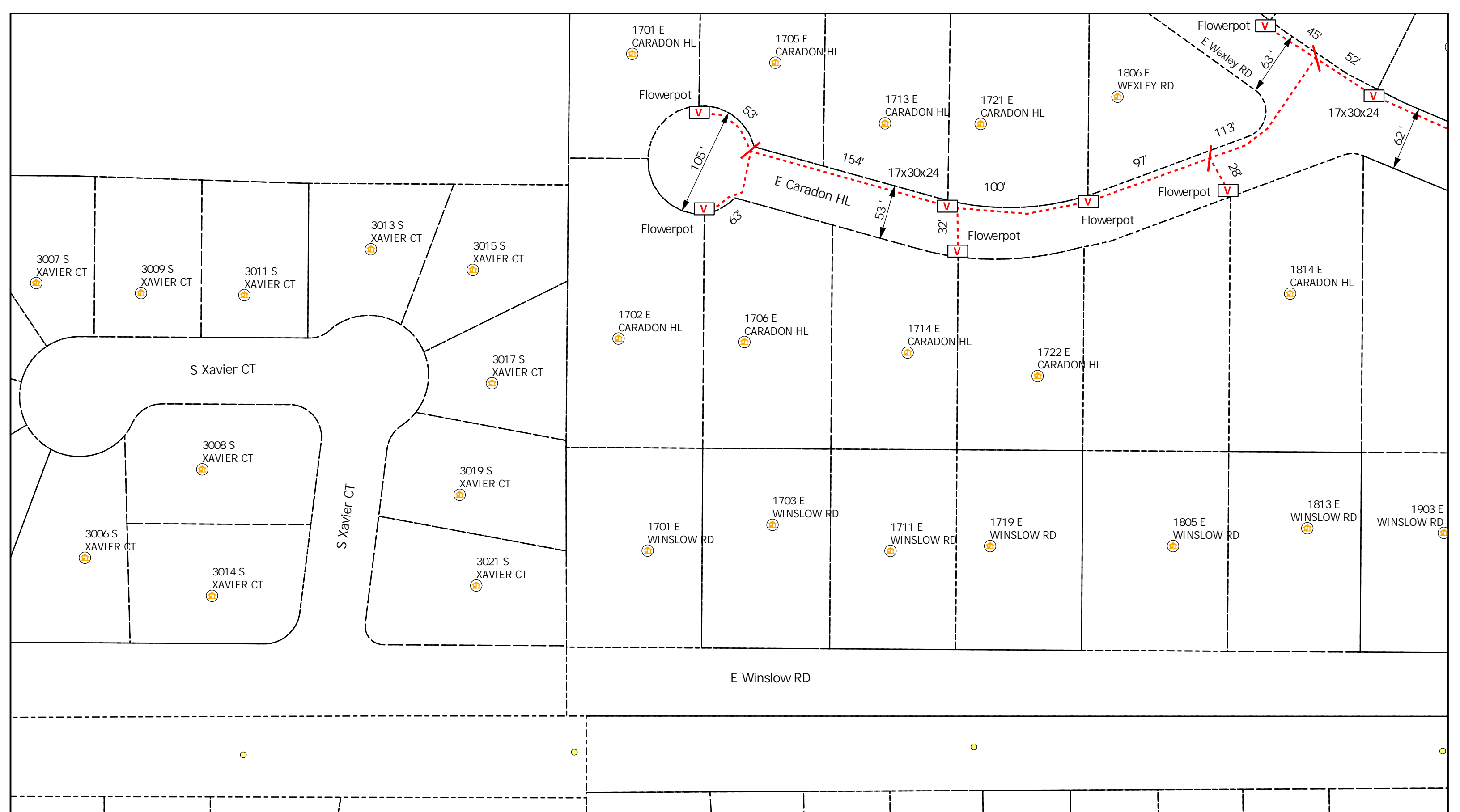

0 20 40 80 Feet

**Legend**

- Poles
- Vaults
- Overhead Strand
- Conduit
- Bloomington\_Parcels
- Risers
- Address
- Anchor
- Sidewalk
- Grids

All Flowerpots 12" DIA



City of Bloomington, IN Permit:  
Design View

INI	BY	DATE	DESCRIPTION



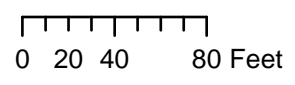
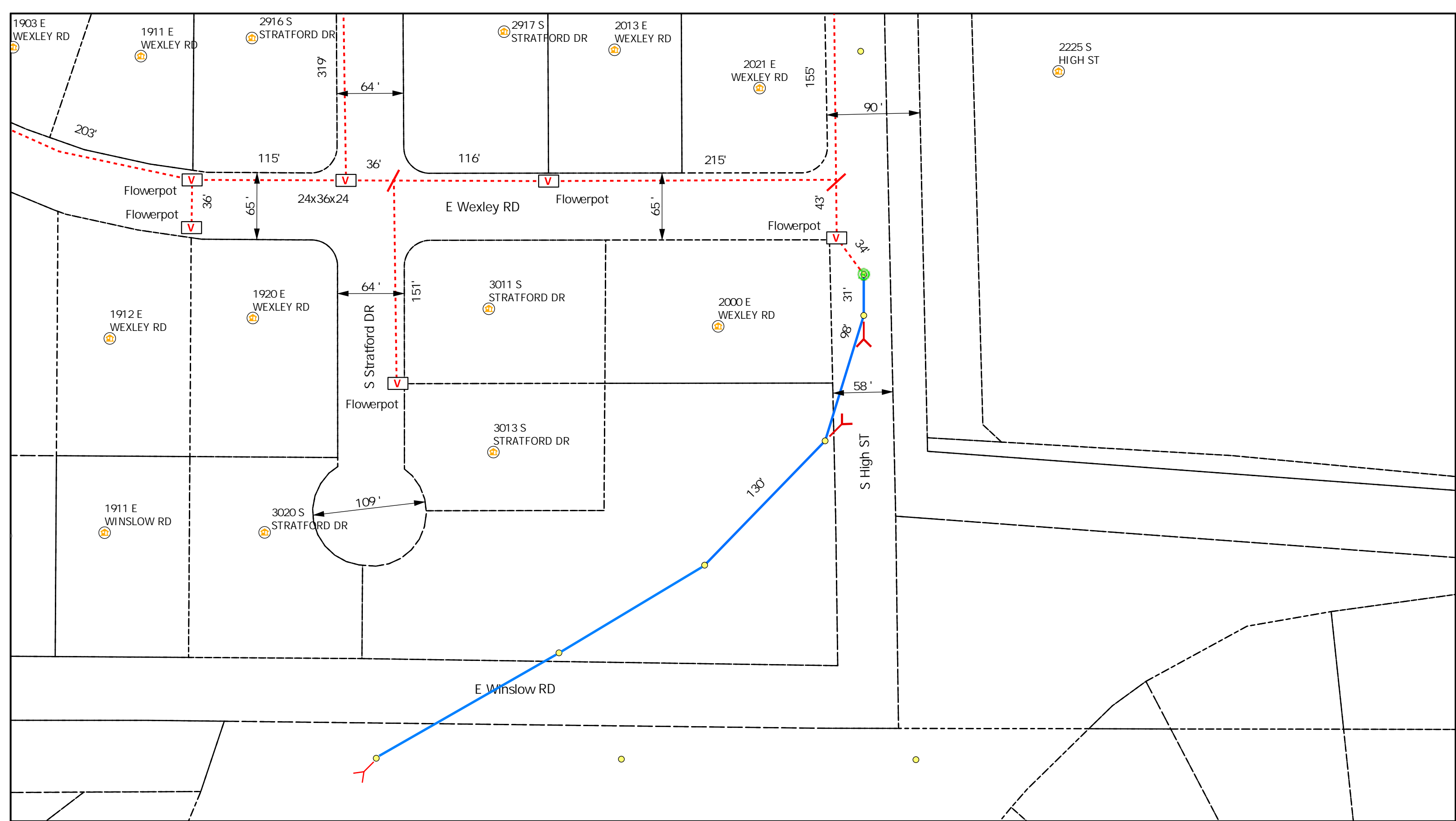

**Legend**

- Poles
- V Vaults
- Overhead Strand
- Conduit
- Bloomington\_Parcels
- R Risers
- Ⓜ Address
- Y Anchor
- ← Sidewalk
- Grids

All Flowerpots 12" DIA



City of Bloomington, IN Permit:  
Design View

INI	BY	DATE	DESCRIPTION





# Carlton® PV-Mold® Nonmetallic Pole Riser System

Carlton PV-Mold is a nonmetallic pole riser system designed to protect communications power cable installed on poles.

## Features:

- Meets or exceeds requirements outlined in the National Electric Safety Code (NESC).
- Designed in accordance with NEMA TC-19 specifications.
- Ultraviolet, cold temperature and corrosive atmosphere resistant.
- Schedule 40 wall meets Schedule 80 PVC conduit impact requirements per NEMA TC-19.
- No grounding required.
- Belled end fits over each added section or conduit.
- Flame retardant.
- Requires no maintenance.
- PV-Mold acts as an insulator against electrical shock.
- Interchangeable parts and accessories to match the needs of specific requirements.



Steel U-Guard requires grounding strapping and does not have belled ends.



PV-Mold has belled ends, flanged design and does not require grounding.

## Flanged Overall Length 10 Feet, Including Bell

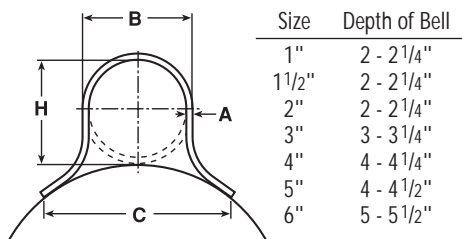

Slots are 1/2" from side to side, and allow for expansion and contraction.

Slot Dimensions: for sizes 2" through 6" are 5/16" wide, 3/4" long.

Slot Dimensions: for 1" and 1 1/2" are 3/16" wide, 3/4" long.

Slot Spacing: 18" from center, beginning 6" from end.

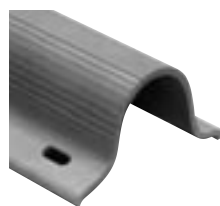

## Standard Duty

Part No.	Size	Std. Ctn. Qty.	Std. Ctn. Wt. (lbs.)	Dimensions				Actual Impact @ 0°C 20 Pound Top
				A	B	C	H	
59208N	1"	294	1059	0.100"	1 5/8"	2 3/8"	1 5/8"	40 Ft.-Lbs.
59211N	2"	136	726	0.100"	2 3/8"	4 1/2"	2 3/8"	100 Ft.-Lbs.
59211X (5' length)	2"	136	363	0.100"	2 3/8"	4 1/2"	2 3/8"	100 Ft.-Lbs.
59213N	3"	66	761	0.150"	3 1/2"	6"	3 1/2"	110 Ft.-Lbs.
59213X (5' length)	3"	66	381	0.150"	3 1/2"	6"	3 1/2"	100 Ft.-Lbs.
59215N	4"	65	910	0.150"	4 1/2"	6 1/2"	4 1/2"	110 Ft.-Lbs.
59216N	5"	30	515	0.150"	5 1/2"	7 1/2"	5 1/2"	110 Ft.-Lbs.

## Heavy Duty Schedule 40

59010N	1 1/2"	200	1142	0.145"	1 29/32"	3 1/2"	1 29/32"	100 Ft.-Lbs.
59011N	2"	136	1214	0.154"	2 3/8"	4 1/2"	2 3/8"	150 Ft.-Lbs.
59013N	3"	66	937	0.216"	3 1/2"	6"	3 9/32"	150 Ft.-Lbs.
59015N	4"	65	1621	0.237"	4 1/2"	6 1/2"	4 1/2"	260 Ft.-Lbs.
59015X (5' length)	4"	65	707	0.237"	4 1/2"	6 1/2"	4 1/2"	260 Ft.-Lbs.
59016N	5"	30	870	0.258"	5 1/2"	7 1/2"	5 1/2"	260 Ft.-Lbs.
59017N	6"	30	1160	0.280"	6 5/8"	8 3/4"	6 5/8"	260 Ft.-Lbs.

## Extra Heavy Duty Schedule 80

59411N	2"	136	1549	0.218"	2 3/8"	4 1/2"	2 3/8"	300 Ft.-Lbs.
59413N	3"	66	1495	0.030"	3 1/2"	6"	3 1/2"	525 Ft.-Lbs.

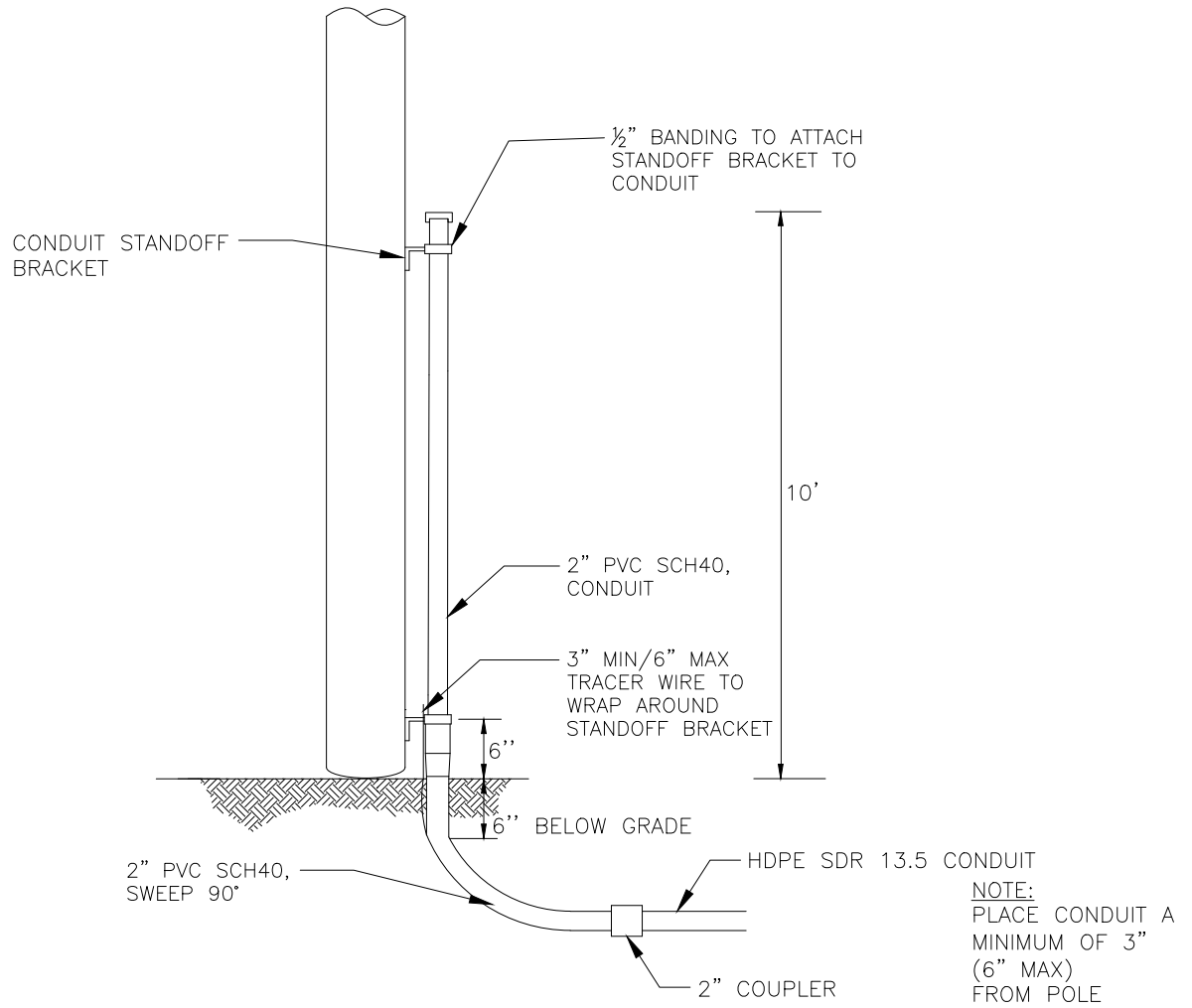

DESCRIPTION	QTY	MANUFACTURER (PREFERRED)	PART #
SCREW, LAG, 1/2" x 4-1/2"	10		
HDPE SDR 13.5 CONDUIT, VARIOUS SIZES	N/A		
2" PVC SCH40, RISER PIPE	1		
#12 TRACER WIRE	N/A		
2" PVC SCH40, SWEEP, 90 DEG	1		
CONDUIT STANDOFF BRACKET	VARIES		
CONDUIT STRAP KIT	VARIES		
2" COUPLER	1		



TYPICAL RISER  
CONDUIT  
WOOD POLE

(R2-W)

# CONCEPTUAL SIDE VIEW

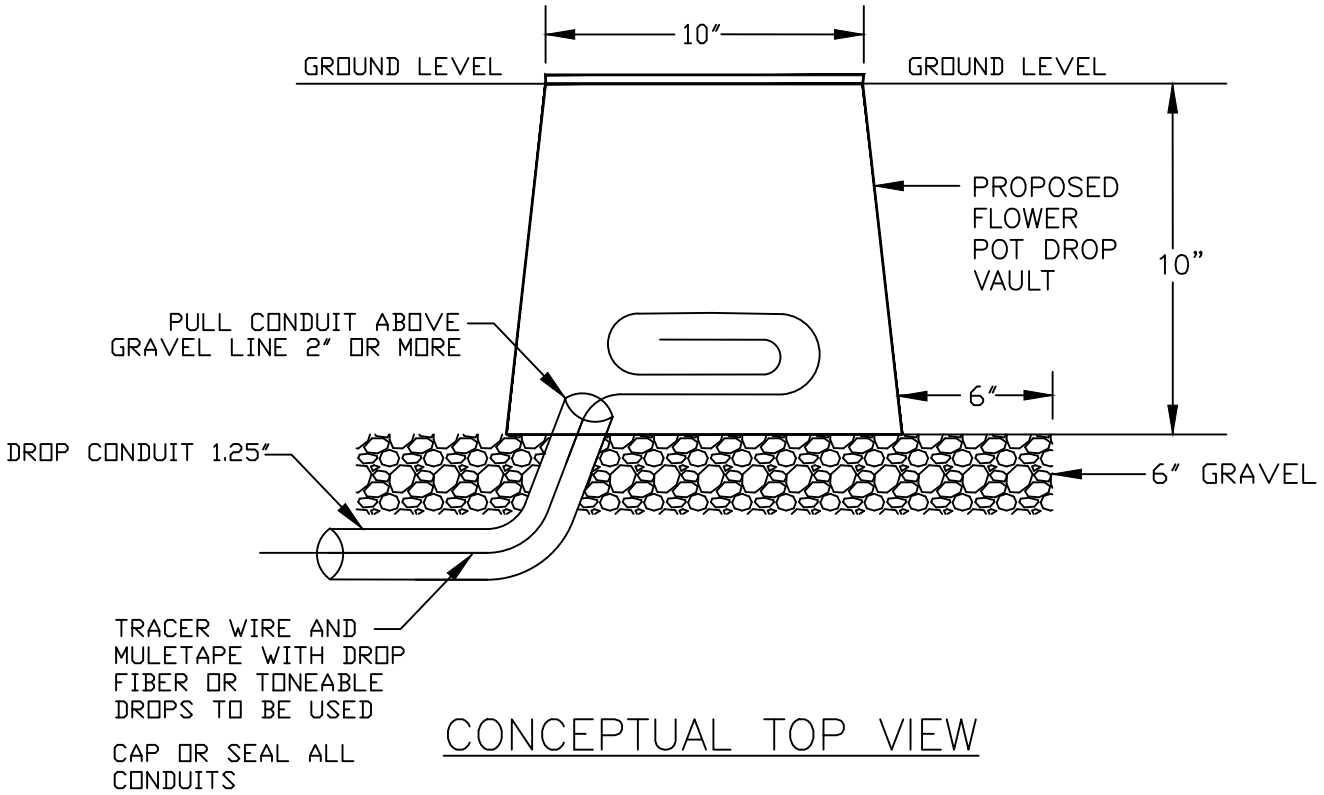

# CONCEPTUAL TOP VIEW

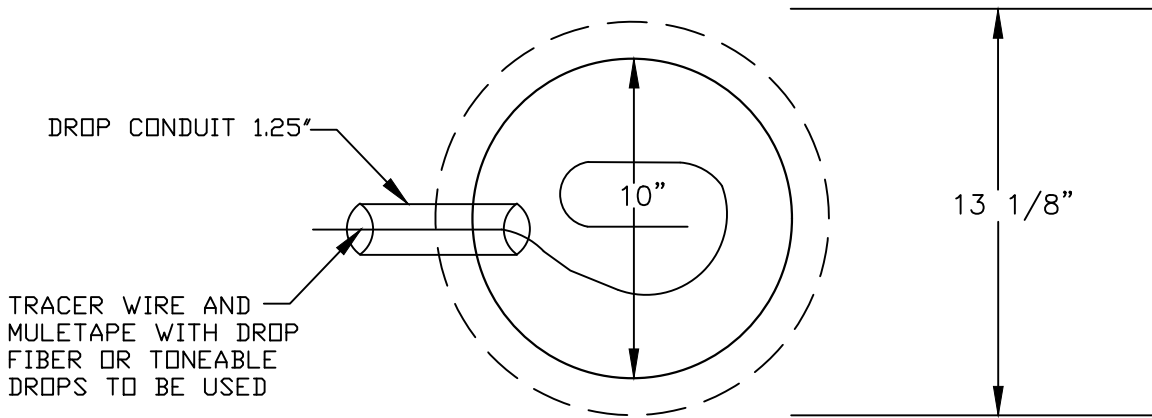

FLOWER POT

30"x48" PC UNIT, 2PC TIER 15/22  
 18", 24", and 36" HEIGHT



AMERICAN POLYMER COMPANY

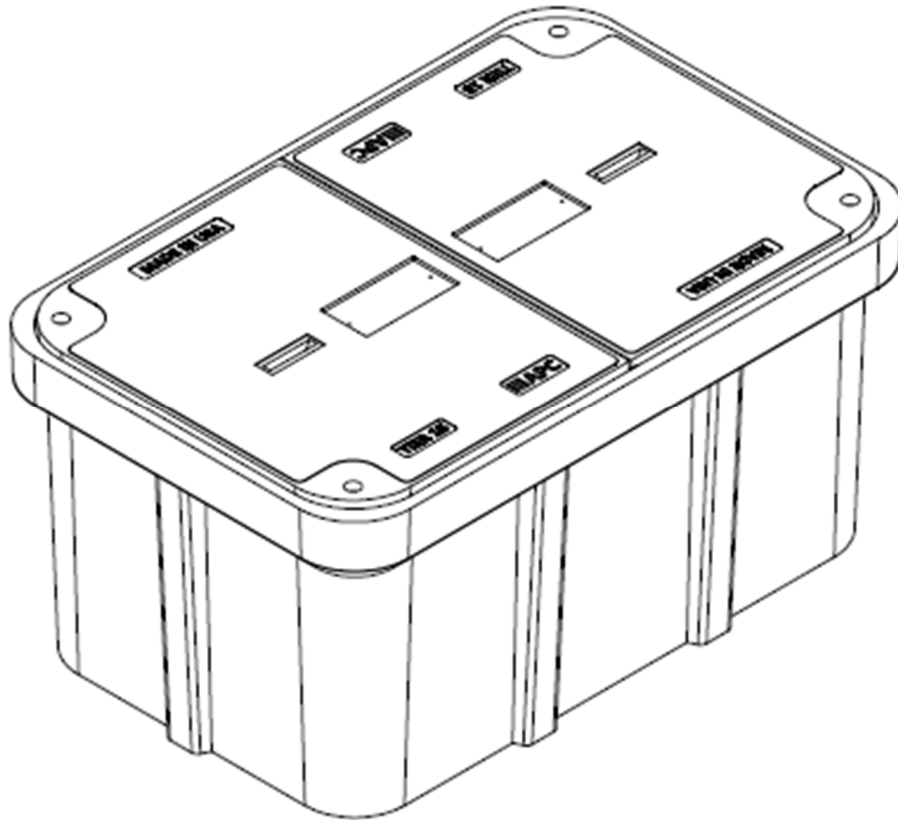

Description	Nominal Size	ANSI Tier	Part Number	Estimated Weight
PC Unit – TIER 15	30"x48"x18"	Tier 15	P304818HU15...	460 lbs.
PC Unit – TIER 22	30"x48"x18"	Tier 22	P304818HU22...	525 lbs.
PC Unit – TIER 15	30"x48"x24"	Tier 15	P304824HU15...	510 lbs.
PC Unit – TIER 22	30"x48"x24"	Tier 22	P304824HU22...	575 lbs.
PC Unit – TIER 15	30"x48"x36"	Tier 15	P304836HU15...	615 lbs.
PC Unit – TIER 22	30"x48"x36"	Tier 22	P304836HU22...	680 lbs.





# 30"x48" PC UNIT, 2PC TIER 15/22

18", 24", and 36" HEIGHT



AMERICAN POLYMER COMPANY

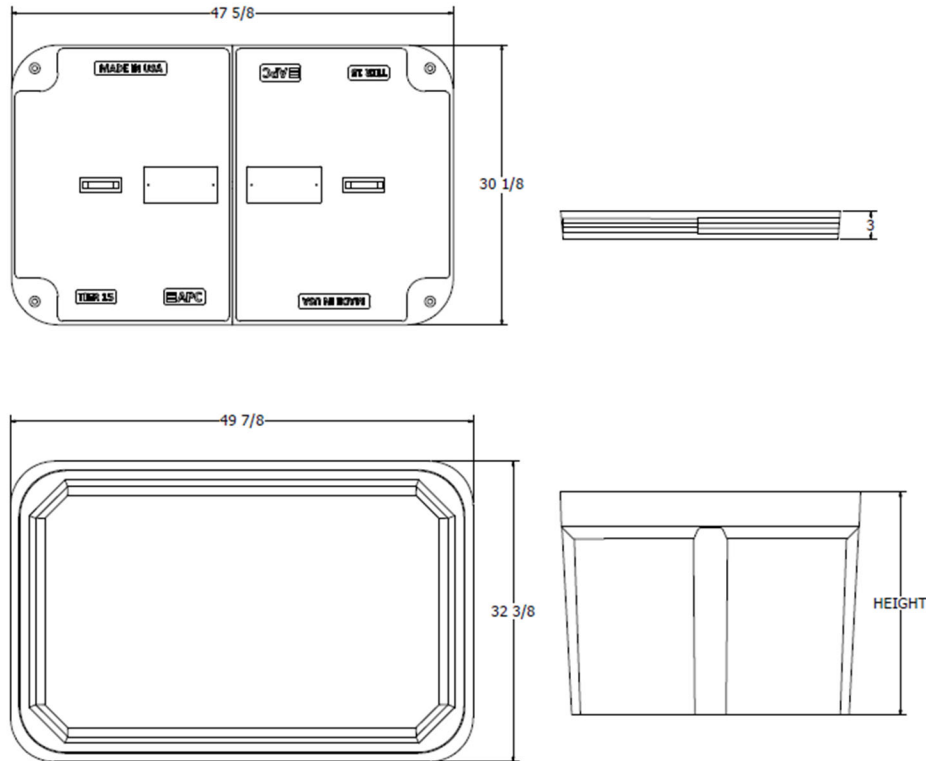

Components	Nominal Size	ANSI Tier	Part Number	Estimated Weight
Replacement Box	30"x48"x18"	Tier 22	P304818B22	185 lbs.
Replacement Box	30"x48"x24"	Tier 22	P304824B22	235 lbs.
Replacement Box	30"x48"x36"	Tier 22	P304836B22	340 lbs.
Replacement Lids - T15	30"x48" (half)	Tier 15	Various	150 lbs.
Replacement Lids - T22	30"x48" (half)	Tier 22	Various	170 lbs.

### Bolt options



Machine Thread



Auger Thread



24"x36" PC UNIT, TIER 15/22  
 18", 24", 30", and 36" HEIGHT



AMERICAN POLYMER COMPANY

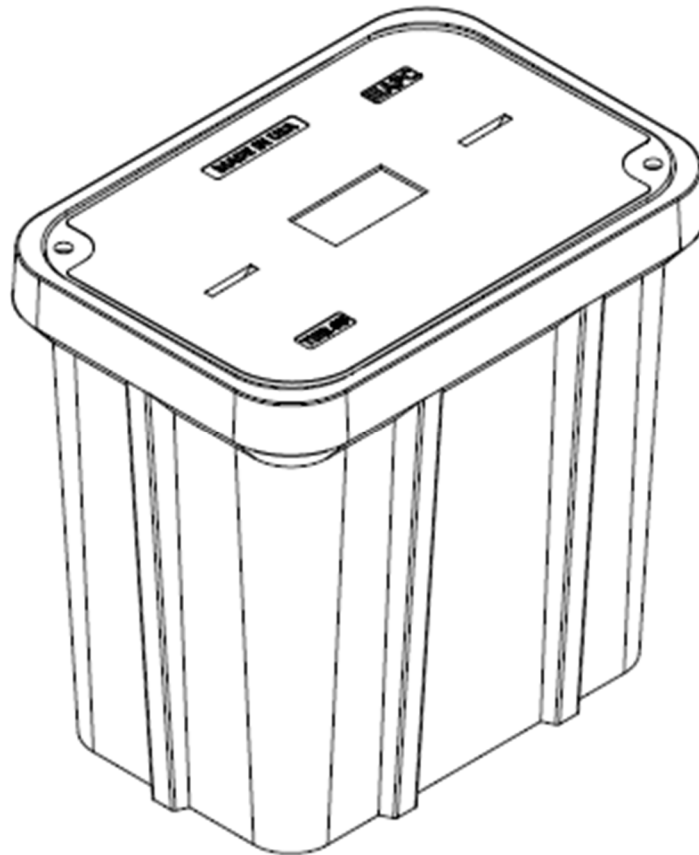

Description	Nominal Size	ANSI Tier	Part Number	Estimated Weight
PC Unit – TIER 15	24x36"x18"	Tier 15	P243618U15...	335 lbs.
PC Unit – TIER 22	24x36"x18"	Tier 22	P243618U22...	355 lbs.
PC Unit – TIER 15	24x36"x24"	Tier 15	P243624U15...	365 lbs.
PC Unit – TIER 22	24x36"x24"	Tier 22	P243624U22...	385 lbs.
PC Unit – TIER 15	24x36"x30"	Tier 15	P243630U15...	395 lbs.
PC Unit – TIER 22	24x36"x30"	Tier 22	P243630U22...	415 lbs.
PC Unit – TIER 15	24x36"x36"	Tier 15	P243636U15...	425 lbs.
PC Unit – TIER 22	24x36"x36"	Tier 22	P243636U22...	445 lbs.



# 24"x36" PC UNIT, TIER 15/22

18", 24", 30", and 36" HEIGHT



AMERICAN POLYMER COMPANY

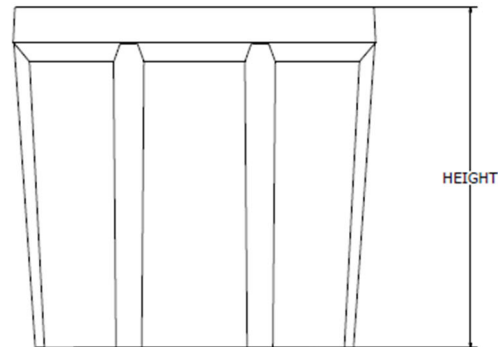
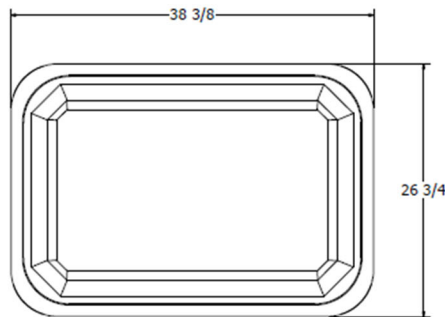
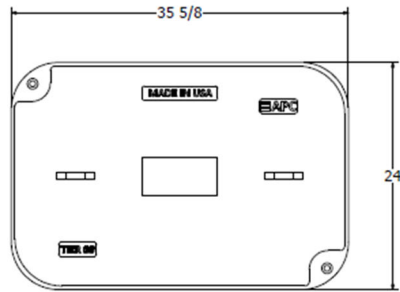

Components	Nominal Size	ANSI Tier	Part Number	Estimated Weight
Replacement Box	24"x36"x18"	Tier 22	P243618B22	165 lbs.
Replacement Box	24"x36"x24"	Tier 22	P243624B22	195 lbs.
Replacement Box	24"x36"x30"	Tier 22	P243630B22	225 lbs.
Replacement Box	24"x36"x36"	Tier 22	P243636B22	255 lbs.
Replacement Lids - T15	24"x36"	Tier 15	Various	170 lbs.
Replacement Lids - T22	24"x36"	Tier 22	Various	190 lbs.

### Bolt options

Hex Head



Machine Thread



Penta Head



Auger Thread



17"x30" PC UNIT, TIER 15/22

12", 18", 24", and 30" HEIGHT



AMERICAN POLYMER COMPANY

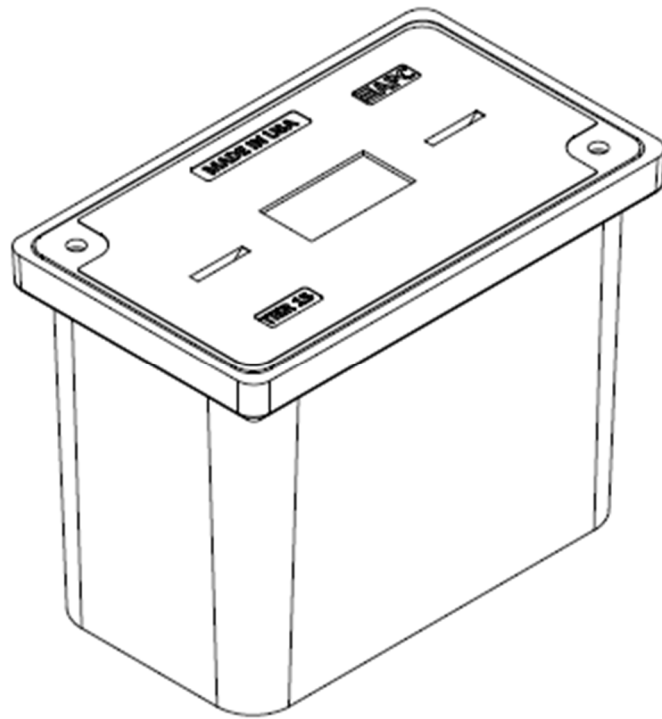

Description	Nominal Size	ANSI Tier	Part Number	Estimated Weight
PC Unit – TIER 15	17"x30"x12"	Tier 15	P173012U15...	138 lbs.
PC Unit – TIER 22	17"x30"x12"	Tier 22	P173012U22...	147 lbs.
PC Unit – TIER 15	17"x30"x18"	Tier 15	P173018U15...	172 lbs.
PC Unit – TIER 22	17"x30"x18"	Tier 22	P173018U22...	181 lbs.
PC Unit – TIER 15	17"x30"x24"	Tier 15	P173024U15...	192 lbs.
PC Unit – TIER 22	17"x30"x24"	Tier 22	P173024U22...	201 lbs.
PC Unit – TIER 15	17"x30"x30"	Tier 15	P173030U15...	217 lbs.
PC Unit – TIER 22	17"x30"x30"	Tier 22	P173030U22...	226 lbs.





# 17"x30" PC UNIT, TIER 15/22

12", 18", 24", and 30" HEIGHT



AMERICAN POLYMER COMPANY

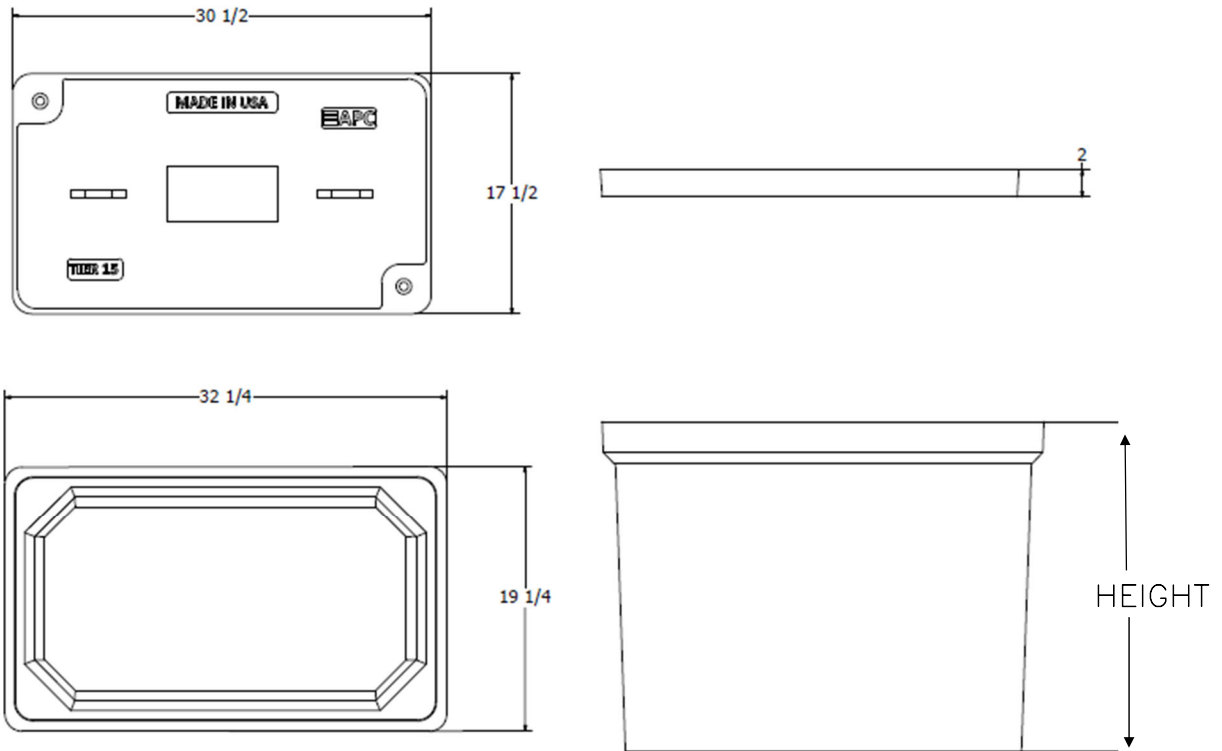

Components	Nominal Size	ANSI Tier	Part Number	Estimated Weight
Replacement Box	17"x30"X12"	Tier 22	P173012B22	66 lbs.
Replacement Box	17"x30"X18"	Tier 22	P173018B22	100 lbs.
Replacement Box	17"x30"X24"	Tier 22	P173024B22	120 lbs.
Replacement Box	17"x30"X30"	Tier 22	P173030B22	145 lbs.
Replacement Lids – T15	17"x30"	Tier 15	Various	72 lbs.
Replacement Lids – T22	17"x30"	Tier 22	Various	81 lbs.

### Bolt options



Machine Thread



Auger Thread



33"x60" PC UNIT, 2PC TIER 15/22  
36" HEIGHT



AMERICAN POLYMER COMPANY

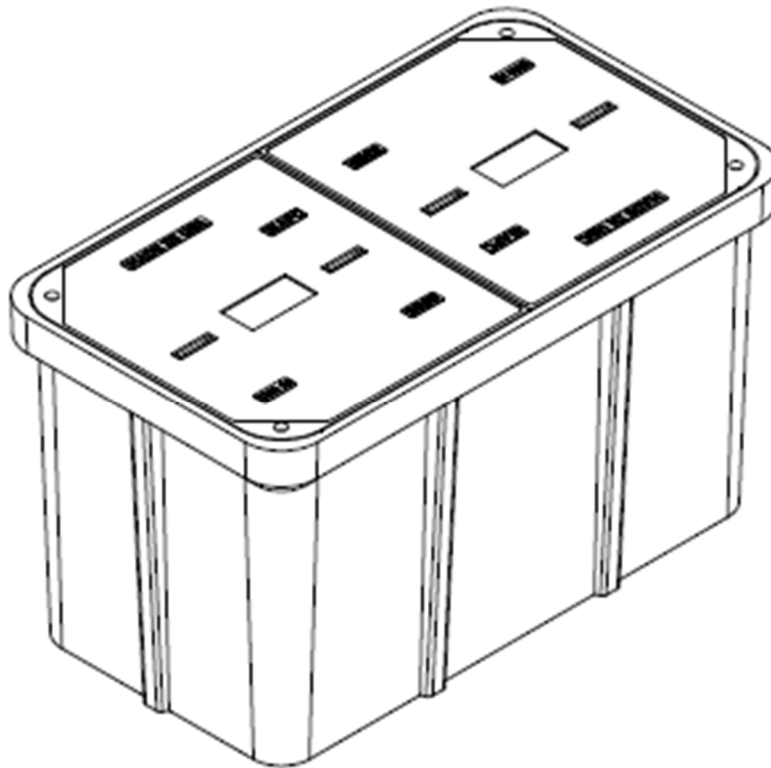

Description	Nominal Size	ANSI Tier	Part Number	Estimated Weight
PC Unit - TIER 15	33"x60"x36"	Tier 15	P336036U15...	930 lbs.
PC Unit - TIER 22	33"x60"x36"	Tier 22	P336036U22...	1030 lbs.



# 33"x60" PC UNIT, 2PC TIER 15/22

## 36" HEIGHT



AMERICAN POLYMER COMPANY

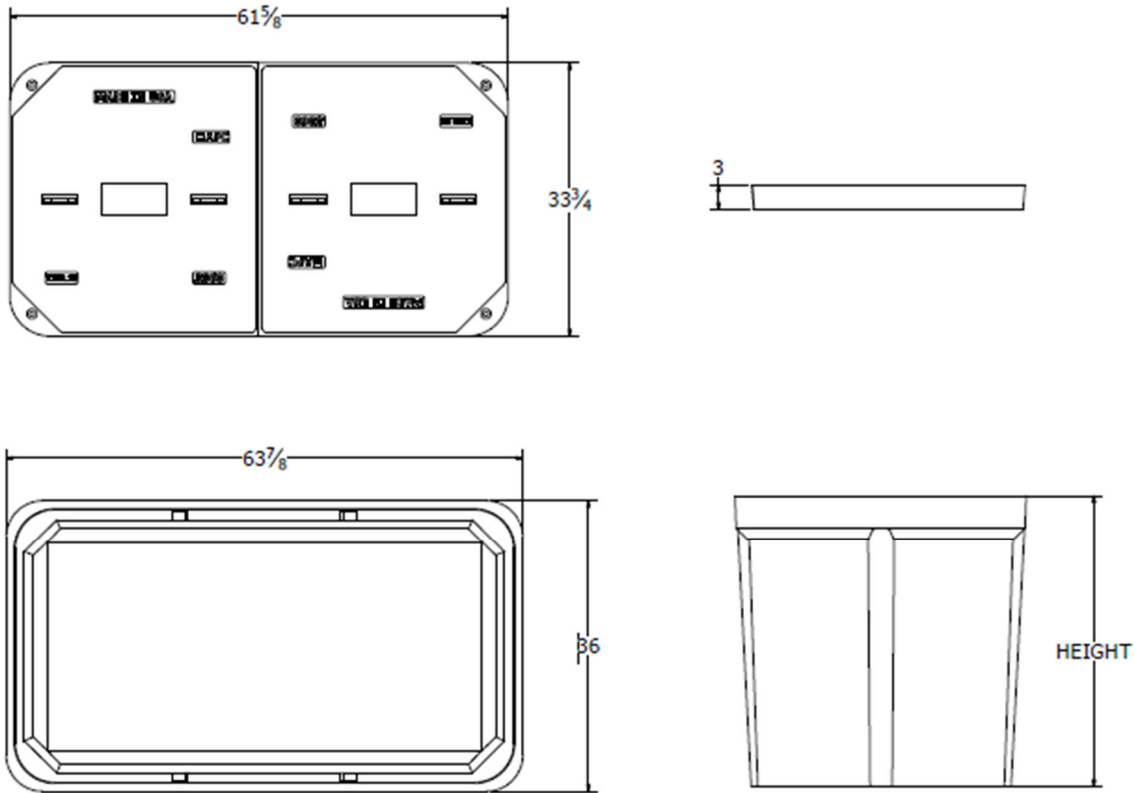

Components	Nominal Size	ANSI Tier	Part Number	Estimated Weight
Replacement Box	33"x60"x36"	Tier 22	P336036B22	530 lbs.
Replacement Lids - T15	33"x60" (half)	Tier 15	Various	200 lbs.
Replacement Lids - T22	33"x60" (half)	Tier 22	Various	250 lbs.

### Bolt options

Hex Head



Machine Thread



Penta Head



Auger Thread





Speed (MPH) Prior To Road Work	SIGN SPACING, FT.		Must be Approved by an Engineer				
	Non-Divided Highways	Divided Highways	BUFFER SPACE, FT.	TAPER LENGTH, FT.	CHANNELIZING SPACING, FT.		
	Length	Shoulder (10 ft. Width)	Lane (12 ft. Width)	Through Taper	Through Buffer/Work Area		
0-35	200	200	250	70	245	35	50
40-45	350	500	360	150	540	40	80
50-55	500	1000	495	185	660	50	100
60-70	SA-1000, SB-1500, SC-2640		730	235	840	60	120
	Urban Low Speed - 100 FT						

APPROVED/ACCEPTED BY:  
ENGINEER, OWNER, or PRIME CONTRACTOR  
 Check for Notice to Proceed.  
**BLC02a-F12\_S High St - TCP1**

Signature: \_\_\_\_\_

Company: \_\_\_\_\_

**Road Runner**  
Safety Services, Inc.

Date: 1/19/2023 Project: BLC02a-F12 S High St - TCP :  
Traffic Control Suggestion For: AEG :  
By: Road Runner Safety Services, Inc. : Nathan

Comments:  
Drawing not to scale. Traffic control plan must be approved by an engineer. This is a suggestion only. Road Runners Safety Services, Inc. has no liability for this suggested traffic control plan. Actual placement and spacing of all traffic control devices will depend on field conditions and must conform to MUTCD standards.

- Legend**
- ADA Barricade
  - Channelizer
  - Conduit
  - Flagger (Person)
  - Overhead Strand
  - Sign
  - Vault
  - Work Area

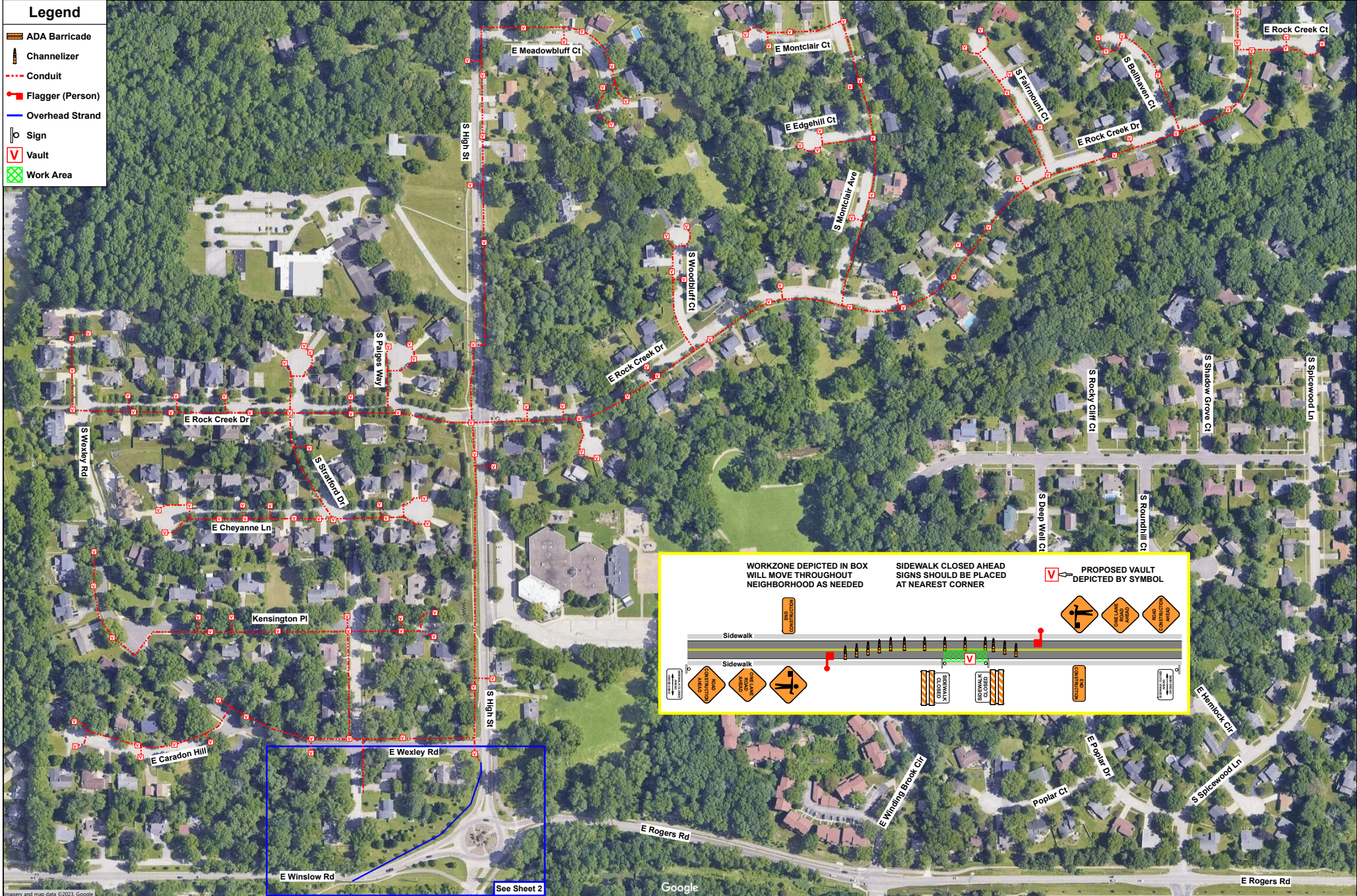



Spacing Charts Based on MUTCD		Must be Approved by an Engineer					
Speed (MPH) Prior To Road Work	SIGN SPACING, FT.		BUFFER SPACE, FT.	TAPER LENGTH, FT.		CHANNELIZING SPACING, FT.	
	Non-Divided Highways	Divided Highways	Length	Shoulder (10 ft Width)	Lane (12 ft Width)	Through Taper	Through Buffer/Work Area
0-35	200	200	250	70	245	35	50
40-45	350	500	360	150	540	40	80
50-55	500	1000	495	185	660	50	100
60-70	SA-1000, SB-1500, SC-2640		730	235	840	60	120
	Urban Low Speed - 100 FT						

APPROVED/ACCEPTED BY:  
ENGINEER, OWNER, or PRIME CONTRACTOR

Check for Notice to Proceed.  
BLC02a-F12\_S High St - TCP2

Signature: \_\_\_\_\_

Company: \_\_\_\_\_

**Date:** 1/19/2023 **Project:** BLC02a-F12\_S High St - TCP :  
: **Traffic Control Suggestion For:** AEG :  
**By:** Road Runner Safety Services, Inc. : Nathan

**Comments:**  
Drawing not to scale. Traffic control plan must be approved by an engineer. This is a suggestion only. Road Runners Safety Services, Inc. has no liability for this suggested traffic control plan. Actual placement and spacing of all traffic control devices will depend on field conditions and must conform to MUTCD standards.



Legend	
	Additional Work Area
	Channelizer
	Conduit
	Flagger (Person)
	Overhead Strand
	Vault
	Work Area

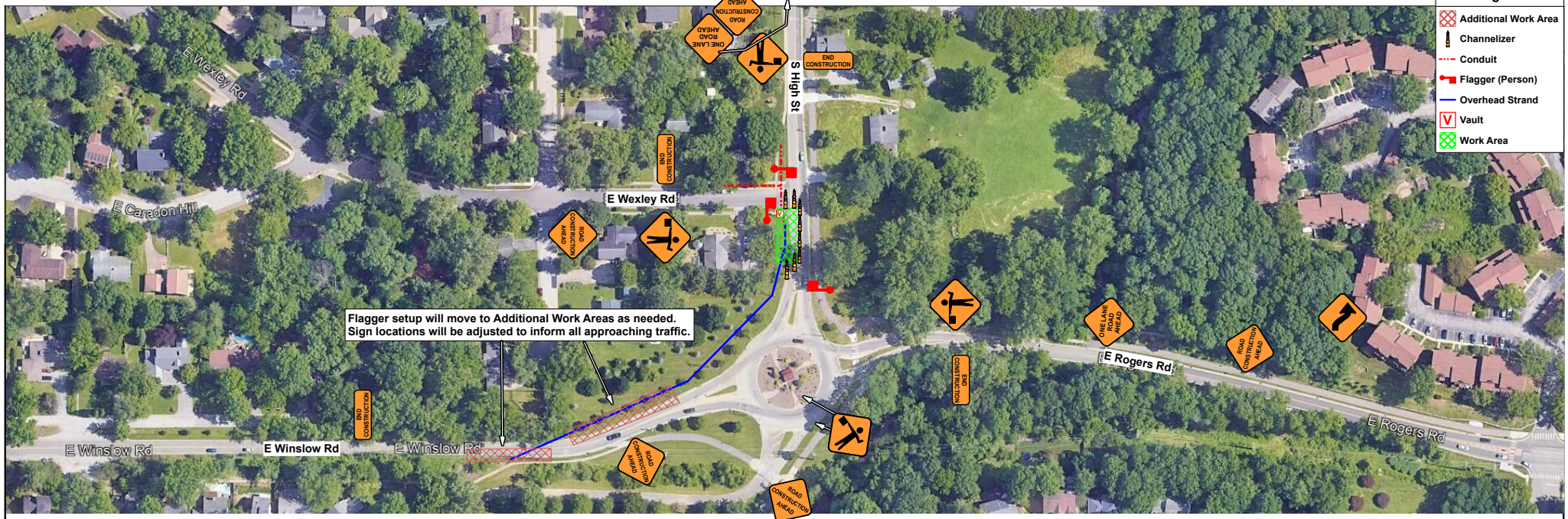







## Board of Public Works Staff Report

---

**Project/Event:** Rejection of Bids for Hopewell Phase I East Infrastructure Project

**Petitioner/Representative:** Engineering Department

**Staff Representative:** Matt Smethurst

**Meeting Date:** January 31, 2023

---

On January 9th, 2023, staff opened bids that were solicited by the Engineering Department for the Hopewell Phase I East Infrastructure Project.

A base bid of \$13,568,269.00 was received from Milestone Contractors, LP. Milestone submitted a bid of \$712,770.00 for Alternate 1, a bid of \$330,000.00 for Alternate 2, and a bid of \$623,070.00 for Alternate 3.

The bid received for the project was significantly higher than the engineer's estimate for the project. As such, staff is asking the Board to reject the bid for the project. If the bid is rejected, staff would solicit bids again for the project later this year.



# Board of Public Works Claim Register

Invoice Date Range 01/21/23 - 02/03/23

Vendor	Invoice Description	Invoice Date	Board Number	Payment Date	Invoice Amount
<b>Fund 101 - General Fund (S0101)</b>					
Department 01 - Animal Shelter					
Program 010000 - Main					
Account 43430 - Animal Adoption Fees					
Drake Robertson	01-refund adoption fee/rabbies vac-1/14/23	01/24/2023		02/03/2023	75.00
Billie Smith	01-refund adoption fee/rabbies vac-1/17/23	01/24/2023		02/03/2023	75.00
Emma Talbert	01-refund adoption fee-canine-1/20/23	01/24/2023		02/03/2023	75.00
			Account 43430 - Animal Adoption Fees Totals	3	<u>\$225.00</u>
Account 43442 - Equipment Deposits					
Christopher Ricker	01-Returned Trap-refund deposit-1/17/23	01/24/2023		02/03/2023	40.00
Karen Sweeny	01-Returned Trap-refund deposit-1/10/23	01/24/2023		02/03/2023	220.00
			Account 43442 - Equipment Deposits Totals	2	<u>\$260.00</u>
Account 43460 - Medical					
Drake Robertson	01-refund adoption fee/rabbies vac-1/14/23	01/24/2023		02/03/2023	15.00
Billie Smith	01-refund adoption fee/rabbies vac-1/17/23	01/24/2023		02/03/2023	15.00
			Account 43460 - Medical Totals	2	<u>\$30.00</u>
Account 47060 - Refunds					
394 - Kleindorfer Hardware & Variety	01-credit for 750787	01/24/2023		02/03/2023	(1.78)
			Account 47060 - Refunds Totals	1	<u>(\$1.78)</u>
Account 52110 - Office Supplies					
6530 - Office Depot, INC	01-Office Supplies-markers	01/24/2023		02/03/2023	13.51
6530 - Office Depot, INC	01-Office Supplies-envelopes, staplers, sharpies	01/24/2023		02/03/2023	90.96
			Account 52110 - Office Supplies Totals	2	<u>\$104.47</u>
Account 52210 - Institutional Supplies					
4832 - Animal Care Equipment & Services, LLC	01-Muzzles	01/24/2023		02/03/2023	160.56
4136 - C. Specialties, INC	01-Leashes & Carriers	01/24/2023		02/03/2023	2,203.79
4586 - Hill's Pet Nutrition Sales, INC	01-Prescription Veterinary Food	01/24/2023		02/03/2023	110.42
4586 - Hill's Pet Nutrition Sales, INC	01-Dog & Cat Food	01/24/2023		02/03/2023	158.64
4586 - Hill's Pet Nutrition Sales, INC	01-Dog & Cat Food	01/24/2023		02/03/2023	261.12
3929 - IDEXX Laboratories, INC	01-Diagnostics; F/F; Heartworm	01/24/2023		02/03/2023	1,152.33
3929 - IDEXX Laboratories, INC	01-Diagnostics; F/F; Heartworm	01/24/2023		02/03/2023	1,782.33
4549 - Kroger Limited Partnership I	01-Rabbit Food & Shelter Supplies	01/24/2023		02/03/2023	42.99





# Board of Public Works Claim Register

Invoice Date Range 01/21/23 - 02/03/23

4633 - Midwest Veterinary Supply, INC	01-Veterinary Supplies	01/24/2023	02/03/2023	183.85
4633 - Midwest Veterinary Supply, INC	01-Veterinary Supplies	01/24/2023	02/03/2023	427.44
5819 - Synchrony Bank	01-Lime Dip & Humidifiers	01/24/2023	02/03/2023	77.74
5819 - Synchrony Bank	01-Lime Dip & Humidifiers	01/24/2023	02/03/2023	129.90
Account <b>52210 - Institutional Supplies</b> Totals			12	<u>\$6,691.11</u>
<b>Account 52310 - Building Materials and Supplies</b>				
4832 - Animal Care Equipment & Services, LLC	01-Hose & Reel	01/24/2023	02/03/2023	750.00
394 - Kleindorfer Hardware & Variety	01-Maintenance & Repair Supplies	01/24/2023	02/03/2023	1.78
Account <b>52310 - Building Materials and Supplies</b> Totals			2	<u>\$751.78</u>
<b>Account 52340 - Other Repairs and Maintenance</b>				
313 - Fastenal Company	01-Cleaning & Shelter Supplies-bleach, towels	01/24/2023	02/03/2023	73.43
313 - Fastenal Company	01-Cleaning & Shelter Supplies-laundry detergent	01/24/2023	02/03/2023	94.38
Account <b>52340 - Other Repairs and Maintenance</b> Totals			2	<u>\$167.81</u>
<b>Account 53130 - Medical</b>				
3376 - Bloomington Pets Alive, INC	01-Spay/Neuter 1/3-1/12/23	01/24/2023	02/03/2023	5,496.00
54639 - Shake Veterinary Services, INC (Town & Country Vet	01-Spay/Neuter & Other Surgeries	01/24/2023	02/03/2023	693.11
Account <b>53130 - Medical</b> Totals			2	<u>\$6,189.11</u>
<b>Account 53540 - Natural Gas</b>				
222 - Indiana Gas Co. INC (CenterPoint Energy) (Vectren)	01-ACC-gas bill 11/2-12/2/22	01/25/2023	01/25/2023	538.05
6769 - EDF, INC (EDF Energy Services)	06-City Fac.-Natural Gas Commodity-Dec 2022 management fee	01/25/2023	01/25/2023	521.90
Account <b>53540 - Natural Gas</b> Totals			2	<u>\$1,059.95</u>
<b>Account 53610 - Building Repairs</b>				
392 - Koorsen Fire & Security, INC	01-SA Fire Extinguisher	01/24/2023	02/03/2023	244.95
Account <b>53610 - Building Repairs</b> Totals			1	<u>\$244.95</u>
<b>Account 53960 - Grants</b>				
2370 - WildCare, INC	01 - Annual Grant 2022	01/24/2023	02/03/2023	3,900.00
Account <b>53960 - Grants</b> Totals			1	<u>\$3,900.00</u>
Program <b>010000 - Main</b> Totals			32	<u>\$19,622.40</u>
<b>Program 010001 - Donations Over \$5K</b>				
<b>Account 53130 - Medical</b>				
3929 - IDEXX Laboratories, INC	01-Diagnostic Testing: Fecals, Urine & Bloodwork	01/24/2023	02/03/2023	251.14
Account <b>53130 - Medical</b> Totals			1	<u>\$251.14</u>
Program <b>010001 - Donations Over \$5K</b> Totals			1	<u>\$251.14</u>



# Board of Public Works Claim Register

Invoice Date Range 01/21/23 - 02/03/23

Department **02 - Public Works**  
 Program **020000 - Main**  
 Account **46060 - Other Violations**

Bronwyn O'Connor 26-customer mailed in check for \$60, only owed \$30  
 Frank Spence 26-customer paid ticket & then it was made a warning

Department <b>01 - Animal Shelter</b> Totals	33				\$19,873.54
Account <b>46060 - Other Violations</b> Totals	2				\$60.00

Account **52420 - Other Supplies**  
 8511 - AaquaTools, INC

02-Sanitation Cart Cleaning System

Account <b>52420 - Other Supplies</b> Totals	1				\$2,500.00
--	---	--	--	--	------------

Account **53410 - Liability / Casualty Premiums**

19618 - ONI Risk Partners, INC, DBA EPIC Insurance Midwest 10-CL Excess Work Comp 01/01/23-01/01/24  
 19618 - ONI Risk Partners, INC, DBA EPIC Insurance Midwest 10-Surplus Lines Tax-CL Excess Work Comp 1/1/23-1/1/24  
 19618 - ONI Risk Partners, INC, DBA EPIC Insurance Midwest 10-Renewal CL Package 01/01/23-01/01/24

Account <b>53410 - Liability / Casualty Premiums</b> Totals	3				\$342,656.17
---	---	--	--	--	--------------

Account **53650 - Other Repairs**

6378 - ANN-KRISS, LLC 02-Metal Drainage Pipe Repair at Walnut St Garage

Account <b>53650 - Other Repairs</b> Totals	1				\$1,563.00
---	---	--	--	--	------------

Account **53940 - Temporary Contractual Employee**

580 - Express Services, INC 02-Contract for Scooter Enforcement Officers - 10-19-2022  
 580 - Express Services, INC 02-Temporary Scooter Enforcement Officers - 11-30-2022

Account <b>53940 - Temporary Contractual Employee</b> Totals	2				\$544.90
--	---	--	--	--	----------

Account **53990 - Other Services and Charges**

580 - Express Services, INC 02-Temporary Scooter Enforcement Officers - 11-30-2022

Account <b>53990 - Other Services and Charges</b> Totals	1				\$291.69
--	---	--	--	--	----------

Program <b>020000 - Main</b> Totals	10				\$347,615.76
-------------------------------------	----	--	--	--	--------------

Department <b>02 - Public Works</b> Totals	10				\$347,615.76
--	----	--	--	--	--------------

Department **03 - City Clerk**  
 Program **030000 - Main**  
 Account **52110 - Office Supplies**

6530 - Office Depot, INC 03-Clerk Office supplies- city seals  
 6530 - Office Depot, INC 03-Clerk Office supplies-oath of office folders  
 6530 - Office Depot, INC 03-journals  
 6530 - Office Depot, INC 03-Notebooks

01/24/2023	02/03/2023	19.50
01/24/2023	02/03/2023	84.95
01/24/2023	02/03/2023	30.50
01/24/2023	02/03/2023	45.90



# Board of Public Works Claim Register

Invoice Date Range 01/21/23 - 02/03/23

6530 - Office Depot, INC	03-ceramic heaters (2)	01/24/2023	02/03/2023	125.98
		Account <b>52110 - Office Supplies</b> Totals	5	<u>\$306.83</u>
Account <b>52420 - Other Supplies</b>				
651 - Engraving & Stamp Center, INC	03-city seal	01/24/2023	02/03/2023	29.95
		Account <b>52420 - Other Supplies</b> Totals	1	<u>\$29.95</u>
Account <b>53320 - Advertising</b>				
205 - City Of Bloomington	03-BHM sponsorship-platinum level	01/24/2023	02/03/2023	2,000.00
		Account <b>53320 - Advertising</b> Totals	1	<u>\$2,000.00</u>
Account <b>53910 - Dues and Subscriptions</b>				
3913 - Indiana League Of Municipal Clerks & Treasurers	03-ILMCT 2023 Dues-Bolden/McDowell/Stoll/Crosley	01/24/2023	02/03/2023	528.00
		Account <b>53910 - Dues and Subscriptions</b> Totals	1	<u>\$528.00</u>
		Program <b>030000 - Main</b> Totals	8	<u>\$2,864.78</u>
		Department <b>03 - City Clerk</b> Totals	8	<u>\$2,864.78</u>
Department <b>04 - Economic &amp; Sustainable Dev</b>				
Program <b>040000 - Main</b>				
Account <b>52110 - Office Supplies</b>				
4394 - Richardson Enterprises of Blgtn,LLC (FastSigns)	04: reprint of Stryker Towing license decals	01/24/2023	02/03/2023	57.07
		Account <b>52110 - Office Supplies</b> Totals	1	<u>\$57.07</u>
Account <b>53970 - Mayor's Promotion of Business</b>				
5695 - 1818 Apparel Co., INC (dba Freethink ApparelI)	04: TShirts and other swag for Go Bloomington	01/24/2023	02/03/2023	1,628.64
3404 - J.R. Watkins & Family, INC (Signs Now)	04: Marketing Services for GoBloomington	01/24/2023	02/03/2023	874.20
		Account <b>53970 - Mayor's Promotion of Business</b> Totals	2	<u>\$2,502.84</u>
		Program <b>040000 - Main</b> Totals	3	<u>\$2,559.91</u>
Program <b>04WALD - Waldron Arts Center</b>				
Account <b>53990 - Other Services and Charges</b>				
6515 - Green Camino, INC (Earthkeepers)	04: Composting Service Agreement-1/7/2023	01/24/2023	02/03/2023	390.00
		Account <b>53990 - Other Services and Charges</b> Totals	1	<u>\$390.00</u>
		Program <b>04WALD - Waldron Arts Center</b> Totals	1	<u>\$390.00</u>
		Department <b>04 - Economic &amp; Sustainable Dev</b> Totals	4	<u>\$2,949.91</u>
Department <b>05 - Common Council</b>				
Program <b>050000 - Main</b>				
Account <b>52110 - Office Supplies</b>				
651 - Engraving & Stamp Center, INC	05 - Engraved Gavel - 2022 Council President	01/24/2023	02/03/2023	64.90
		Account <b>52110 - Office Supplies</b> Totals	1	<u>\$64.90</u>



# Board of Public Works Claim Register

Invoice Date Range 01/21/23 - 02/03/23

Account **53160 - Instruction**  
8407 - Katherine Rosenbarger

05- hotel/pkg/conf fee-Denver CO-8/4-8/6/22

01/24/2023

02/03/2023

53.84

Account **53160 - Instruction** Totals

1

\$53.84

Account **53230 - Travel**  
8407 - Katherine Rosenbarger

05- hotel/pkg/conf fee-Denver CO-8/4-8/6/22

01/24/2023

02/03/2023

691.93

Account **53230 - Travel** Totals

1

\$691.93

Program **050000 - Main** Totals

3

\$810.67

Department **05 - Common Council** Totals

3

\$810.67

Department **07 - Engineering**  
Program **070000 - Main**  
Account **52110 - Office Supplies**  
6530 - Office Depot, INC

07-Scissors, post-it notes, staple remover\_INV#261468918001

01/24/2023

02/03/2023

26.44

Account **52110 - Office Supplies** Totals

1

\$26.44

Account **52420 - Other Supplies**  
5819 - Synchrony Bank  
5819 - Synchrony Bank

07-Amazon Order\_Dusting wipes\_Dust out spray

01/24/2023

02/03/2023

20.52

07-Amazon Order\_Dusting wipes\_Dust out spray

01/24/2023

02/03/2023

14.78

Account **52420 - Other Supplies** Totals

2

\$35.30

Program **070000 - Main** Totals

3

\$61.74

Department **07 - Engineering** Totals

3

\$61.74

Department **10 - Legal**  
Program **100000 - Main**  
Account **52110 - Office Supplies**  
5819 - Synchrony Bank

10-wireless earbuds

01/24/2023

02/03/2023

120.00

Account **52110 - Office Supplies** Totals

1

\$120.00

Account **53120 - Special Legal Services**  
19660 - Bose McKinney & Evans, LLP  
205 - City Of Bloomington  
7855 - Veritext LLC

10-legal services obtain alcoholic beverage permit Civic Center

01/24/2023

02/03/2023

279.00

10-recording fees-waiver Farmer Woodland Land Holdings

01/24/2023

02/03/2023

25.00

10- transcription services zoning case-Aug-Oct 2022

01/24/2023

02/03/2023

1,520.95

Account **53120 - Special Legal Services** Totals

3

\$1,824.95

Account **53310 - Printing**  
6891 - Gatehouse Media Indiana Holdings

10-publication of 2022 add Appropriation Bond 0005170175

01/24/2023

02/03/2023

42.32

Account **53310 - Printing** Totals

1

\$42.32

Program **100000 - Main** Totals

5

\$1,987.27

Department **10 - Legal** Totals

5

\$1,987.27

Department **11 - Mayor's Office**  
Program **110000 - Main**





# Board of Public Works Claim Register

Invoice Date Range 01/21/23 - 02/03/23

**Account 52420 - Other Supplies**

8541 - Amazon.com Sales, INC (Amazon.com Services LLC)	11 -White board attachments & Power strip	01/24/2023	02/03/2023	65.79
8541 - Amazon.com Sales, INC (Amazon.com Services LLC)	11 -storage boxes, docking station, computer items for comms	01/24/2023	02/03/2023	81.12
<b>Account 52420 - Other Supplies Totals</b>			2	<u>\$146.91</u>

**Account 53320 - Advertising**

50706 - Bloomington Magazine, INC (Bloom Magazine)	11-2023 Advertisements	01/24/2023	02/03/2023	8,370.00
<b>Account 53320 - Advertising Totals</b>			1	<u>\$8,370.00</u>

**Account 53960 - Grants**

8462 - Leadership Bloomington Monroe County Alumni INC	11-2022-2023 Class Sponsorship LBMC Alumni Association	01/24/2023	02/03/2023	500.00
<b>Account 53960 - Grants Totals</b>			1	<u>\$500.00</u>

**Account 53990 - Other Services and Charges**

8363 - Rose Smith	11- reimbursement for snacks/coffee for Cabinet Retreat-12/5/22	01/24/2023	02/03/2023	36.50
<b>Account 53990 - Other Services and Charges Totals</b>			1	<u>\$36.50</u>
<b>Program 110000 - Main Totals</b>			5	<u>\$9,053.41</u>
<b>Department 11 - Mayor's Office Totals</b>			5	<u>\$9,053.41</u>

**Department 12 - Human Resources**

**Program 120000 - Main**

**Account 52110 - Office Supplies**

6530 - Office Depot, INC	12-calendars	01/24/2023	02/03/2023	60.68
6530 - Office Depot, INC	12-planners	01/24/2023	02/03/2023	59.98
<b>Account 52110 - Office Supplies Totals</b>			2	<u>\$120.66</u>

**Account 53320 - Advertising**

6891 - Gatehouse Media Indiana Holdings	12-HT Job Ads	01/24/2023	02/03/2023	380.54
<b>Account 53320 - Advertising Totals</b>			1	<u>\$380.54</u>

**Account 53990 - Other Services and Charges**

585 - Bloomington Public Transportation Corporation	12-Oct - Dec 2022 City Employee Pass Program	01/24/2023	02/03/2023	128.25
6099 - Safe Hiring Solutions	12-out of state background check	01/24/2023	02/03/2023	107.45
<b>Account 53990 - Other Services and Charges Totals</b>			2	<u>\$235.70</u>
<b>Program 120000 - Main Totals</b>			5	<u>\$736.90</u>
<b>Department 12 - Human Resources Totals</b>			5	<u>\$736.90</u>

**Department 13 - Planning**

**Program 130000 - Main**

**Account 42080 - F.H.W.A. Planning**



# Board of Public Works Claim Register

Invoice Date Range 01/21/23 - 02/03/23

585 - Bloomington Public Transportation Corporation	13-FY 2023 UPWP-Q1-May 2022-Alt Fuel/Infrastructure-Q	01/24/2023	02/03/2023	10,833.14
585 - Bloomington Public Transportation Corporation	13-FY 2023 UPWP-Q1-June 2022-Alt Fuel/Infrastructure-Q	01/24/2023	02/03/2023	11,949.26
585 - Bloomington Public Transportation Corporation	13-FY 2023 UPWP Q1 July 2022-Alt Fuel & Infrastructure	01/24/2023	02/03/2023	757.73
205 - City Of Bloomington	13-FY 2023 UPWP-Q1 Asset Management	01/24/2023	02/03/2023	4,274.26
199 - Monroe County Government	13-FY 2023 UPWP-Q1-Infrastructure Management Systems	01/24/2023	02/03/2023	5,425.39
Account <b>42080 - F.H.W.A. Planning</b> Totals			5	<u>\$33,239.78</u>
<b>Account 53170 - Mgt. Fee, Consultants, and Workshops</b>				
8305 - Schmidt Associates, INC	13-Design Serv_Architecture & Design Review-Dev. Proj-Dec 2022	01/24/2023	02/03/2023	3,081.25
8305 - Schmidt Associates, INC	13-Design Serv_Architecture & Design Review-Dev. Proj-Nov 2022	01/24/2023	02/03/2023	3,572.50
Account <b>53170 - Mgt. Fee, Consultants, and Workshops</b> Totals			2	<u>\$6,653.75</u>
<b>Account 53990 - Other Services and Charges</b>				
2165 - Matthew D Ellenwood	13 - ADU Design Services-Nov-Dec 2022	01/24/2023	02/03/2023	3,000.00
Account <b>53990 - Other Services and Charges</b> Totals			1	<u>\$3,000.00</u>
Program <b>130000 - Main</b> Totals			8	<u>\$42,893.53</u>
Department <b>13 - Planning</b> Totals			8	<u>\$42,893.53</u>
<b>Department 19 - Facilities Maintenance</b>				
<b>Program 190000 - Main</b>				
<b>Account 52310 - Building Materials and Supplies</b>				
409 - Black Lumber Co. INC	19-(4)4" BL Line strip w/frame,(2)5 gal paint grid,Roller Handle	01/24/2023	02/03/2023	40.93
177 - Indiana Oxygen Company, INC	19- small acetylene & HP for City Hall tools	01/24/2023	02/03/2023	41.54
394 - Kleindorfer Hardware & Variety	19-snow shovel & (2) 16" Shelf brackets	01/24/2023	02/03/2023	56.97
394 - Kleindorfer Hardware & Variety	19- brackets,extension handle,roller frame,paint can grid,screws	01/24/2023	02/03/2023	57.17
394 - Kleindorfer Hardware & Variety	19-buckets, paint handles & grids, paint pen, appl touch up	01/24/2023	02/03/2023	59.34
394 - Kleindorfer Hardware & Variety	19-screws, caulk,concrete epoxy,brush,scraper,bit, drive anchors	01/24/2023	02/03/2023	98.91
394 - Kleindorfer Hardware & Variety	19-bolts,togglwings,screws,polish,aerator,chipbrush,rollercover	01/24/2023	02/03/2023	243.14
Account <b>52310 - Building Materials and Supplies</b> Totals			7	<u>\$598.00</u>
<b>Account 52420 - Other Supplies</b>				
8511 - AaquaTools, INC	02-Sanitation Cart Cleaning System	01/24/2023	02/03/2023	2,974.00
Account <b>52420 - Other Supplies</b> Totals			1	<u>\$2,974.00</u>
<b>Account 52430 - Uniforms and Tools</b>				
19171 - Aramark Uniform & Career Apparel Group, INC	19- Work Uniforms for Facility Employees - 1/5/2023	01/24/2023	02/03/2023	30.84
19171 - Aramark Uniform & Career Apparel Group, INC	19- Work Uniforms for Facility Employees - 12/1/2022	01/24/2023	02/03/2023	30.84



# Board of Public Works Claim Register

Invoice Date Range 01/21/23 - 02/03/23

19171 - Aramark Uniform & Career Apparel Group, INC	19-Work Uniforms for Facility Employees - 12/15/2022	01/24/2023		02/03/2023	30.84
19171 - Aramark Uniform & Career Apparel Group, INC	19-Work Uniforms for Facility Employees - 12/22/2022	01/24/2023		02/03/2023	30.84
19171 - Aramark Uniform & Career Apparel Group, INC	19 - Work Uniforms for Facility Employees - 1-12-23	01/24/2023		02/03/2023	30.84
19171 - Aramark Uniform & Career Apparel Group, INC	19 - Work Uniforms for Facility Employees - 12-29-2022	01/24/2023		02/03/2023	30.84
Account <b>52430 - Uniforms and Tools</b> Totals				6	<u>\$185.04</u>
<b>Account 53610 - Building Repairs</b>					
321 - Harrell Fish, INC (HFI)	19-SA Quarterly Planned Maintenance Jan 2023	01/24/2023	BC 2022-115	02/03/2023	2,087.84
1537 - Indiana Door & Hardware Specialties, INC	19- SA Service Call to Adjust Main Entry Door	01/24/2023	BC 2022-107	02/03/2023	75.00
7402 - Nature's Way, INC	19-Plant Maintenance @ City Hall - 1/1/2023	01/24/2023	BC 2022-118	02/03/2023	353.43
Account <b>53610 - Building Repairs</b> Totals				3	<u>\$2,516.27</u>
Program <b>190000 - Main</b> Totals				17	<u>\$6,273.31</u>
Department <b>19 - Facilities Maintenance</b> Totals				17	<u>\$6,273.31</u>
<b>Department 28 - ITS</b>					
<b>Program 280000 - Main</b>					
<b>Account 53170 - Mgt. Fee, Consultants, and Workshops</b>					
8535 - NextRequest LLC	28-SFW-Legal managing public records requests-1/16/23-1/15/24	01/24/2023		02/03/2023	4,194.00
Account <b>53170 - Mgt. Fee, Consultants, and Workshops</b> Totals				1	<u>\$4,194.00</u>
Program <b>280000 - Main</b> Totals				1	<u>\$4,194.00</u>
Department <b>28 - ITS</b> Totals				1	<u>\$4,194.00</u>
Fund <b>101 - General Fund (S0101)</b> Totals				102	<u>\$439,314.82</u>
<b>Fund 176 - ARPA Local Fiscal Recvry (S9512)</b>					
<b>Department 04 - Economic &amp; Sustainable Dev</b>					
<b>Program G21005 - ARPA COVID Local Fiscal Recovery</b>					
<b>Account 53170 - Mgt. Fee, Consultants, and Workshops</b>					
8448 - TEN31 Marketing LLC	04: Marketing Services for GoBloomington-Dec 2022	01/24/2023		02/03/2023	2,030.00
Account <b>53170 - Mgt. Fee, Consultants, and Workshops</b> Totals				1	<u>\$2,030.00</u>
Program <b>G21005 - ARPA COVID Local Fiscal Recovery</b> Totals				1	<u>\$2,030.00</u>
Department <b>04 - Economic &amp; Sustainable Dev</b> Totals				1	<u>\$2,030.00</u>
<b>Department 20 - Street</b>					
<b>Program G21005 - ARPA COVID Local Fiscal Recovery</b>					
<b>Account 53410 - Liability / Casualty Premiums</b>					
19618 - ONI Risk Partners, INC, DBA EPIC Insurance Midwest	10-CL Excess Work Comp 01/01/23-01/01/24	01/25/2023		01/25/2023	581.52



# Board of Public Works Claim Register

Invoice Date Range 01/21/23 - 02/03/23

19618 - ONI Risk Partners, INC, DBA EPIC Insurance Midwest	10-Surplus Lines Tax-CL Excess Work Comp 1/1/23-1/1/24	01/25/2023	01/25/2023	14.55
19618 - ONI Risk Partners, INC, DBA EPIC Insurance Midwest	10-Renewal CL Package 01/01/23-01/01/24	01/25/2023	01/25/2023	82,600.32
Account <b>53410 - Liability / Casualty Premiums</b> Totals			3	\$83,196.39
<b>Account 54420 - Purchase of Equipment</b>				
786 - Richard's Small Engine, INC	20-60" 40HPVanguard EFI OGS Mower (BB Contract #611-20)	01/24/2023	02/03/2023	2,811.43
Account <b>54420 - Purchase of Equipment</b> Totals			1	\$2,811.43
Program <b>G21005 - ARPA COVID Local Fiscal Recovery</b> Totals			4	\$86,007.82
Department <b>20 - Street</b> Totals			4	\$86,007.82
Fund <b>176 - ARPA Local Fiscal Recvry (S9512)</b> Totals			5	\$88,037.82
<b>Fund 249 - Grants Non Approp</b>				
Department <b>04 - Economic &amp; Sustainable Dev</b>				
Program <b>G22008 - 2021 to 2024 Brownfield</b>				
Account <b>53990 - Other Services and Charges</b>				
4571 - BCA Environmental Consultants, LLC	04:-2021-2024 EPA Brownfield Grant-Program Management-11/10/22	01/24/2023	02/03/2023	640.00
4571 - BCA Environmental Consultants, LLC	04:-2021-2024 EPA Brownfield Grant-Program Mangement-12/10/22	01/24/2023	02/03/2023	640.00
4571 - BCA Environmental Consultants, LLC	04-2021-2024 EPA Brownfield Grant-Eligib Determin & Site Access	01/24/2023	02/03/2023	400.00
Account <b>53990 - Other Services and Charges</b> Totals			3	\$1,680.00
Program <b>G22008 - 2021 to 2024 Brownfield</b> Totals			3	\$1,680.00
Department <b>04 - Economic &amp; Sustainable Dev</b> Totals			3	\$1,680.00
Fund <b>249 - Grants Non Approp</b> Totals			3	\$1,680.00
<b>Fund 312 - Community Services</b>				
Department <b>09 - CFRD</b>				
Program <b>090002 - Com Serv - MLK Comm</b>				
Account <b>53310 - Printing</b>				
11693 - The Award Center, INC	09-MLK Legacy Award Plaque	01/24/2023	02/03/2023	55.00
Account <b>53310 - Printing</b> Totals			1	\$55.00
<b>Account 53990 - Other Services and Charges</b>				
5461 - Nicole Bolden	09-Reimbursement for Park Cannon's Lunch-MLK Speaker 1-16-23	01/24/2023	02/03/2023	27.00
8500 - Chef Lee - In Your Home LLC	09-Catering for MLK Jr. Birthday Celebration Event 1/16/23	01/24/2023	02/03/2023	2,140.00
7096 - Institute for Democratic Ed & Culture (SpeakOut)	09-MLK Speaker Honorarium - Park Cannon	01/24/2023	02/03/2023	4,000.00
1815 - Michael Shermis	09-MLK Speaker Hotel Fees Reimb-Hilton Garden-	01/24/2023	02/03/2023	196.00
1815 - Michael Shermis	09-Airport Parking Reimb-MLK Jr. Event Speaker-1/15/23	01/24/2023	02/03/2023	4.00





# Board of Public Works Claim Register

Invoice Date Range 01/21/23 - 02/03/23

1815 - Michael Shermis	09-Reimb for Park Cannon's Dinner 1-16-23	01/24/2023	02/03/2023	23.28
		Account <b>53990 - Other Services and Charges</b> Totals	6	<u>\$6,390.28</u>
		Program <b>090002 - Com Serv - MLK Comm</b> Totals	7	<u>\$6,445.28</u>
Program <b>090022 - Safe Civil Justice Downtown Int</b>				
Account <b>53960 - Grants</b>				
8539 - Bloomington Homeless Coalition	09-2022 Downtown Outreach Grant - Reimbursable Supplies	01/24/2023	02/03/2023	3,557.73
8539 - Bloomington Homeless Coalition	09-2022 Downtown Outreach Grant - Reimbursable Supplies	01/24/2023	02/03/2023	2,016.91
		Account <b>53960 - Grants</b> Totals	2	<u>\$5,574.64</u>
		Program <b>090022 - Safe Civil Justice Downtown Int</b> Totals	2	<u>\$5,574.64</u>
		Department <b>09 - CFRD</b> Totals	9	<u>\$12,019.92</u>
		Fund <b>312 - Community Services</b> Totals	9	<u>\$12,019.92</u>
Fund <b>401 - Non-Reverting Telecom (S1146)</b>				
Department <b>25 - Telecommunications</b>				
Program <b>256000 - Services</b>				
Account <b>54450 - Equipment</b>				
6222 - Apple, INC	25 - Replacement MacBook	01/24/2023	02/03/2023	2,978.00
5819 - Synchrony Bank	25 - Replacement Monitor	01/24/2023	02/03/2023	492.86
		Account <b>54450 - Equipment</b> Totals	2	<u>\$3,470.86</u>
		Program <b>256000 - Services</b> Totals	2	<u>\$3,470.86</u>
		Department <b>25 - Telecommunications</b> Totals	2	<u>\$3,470.86</u>
		Fund <b>401 - Non-Reverting Telecom (S1146)</b> Totals	2	<u>\$3,470.86</u>
Fund <b>405 - Non-Reverting Improve I(S0113)</b>				
Department <b>06 - Controller's Office</b>				
Program <b>060000 - Main</b>				
Account <b>53120 - Special Legal Services</b>				
19660 - Bose McKinney & Evans, LLP	10-legal services federally funded project-1/9/23	01/24/2023	02/03/2023	3,000.00
19660 - Bose McKinney & Evans, LLP	10-Annexation Remonstrance -December 2022	01/24/2023	02/03/2023	19,264.00
		Account <b>53120 - Special Legal Services</b> Totals	2	<u>\$22,264.00</u>
		Program <b>060000 - Main</b> Totals	2	<u>\$22,264.00</u>
		Department <b>06 - Controller's Office</b> Totals	2	<u>\$22,264.00</u>
		Fund <b>405 - Non-Reverting Improve I(S0113)</b> Totals	2	<u>\$22,264.00</u>
Fund <b>451 - Motor Vehicle Highway(S0708)</b>				
Department <b>20 - Street</b>				
Program <b>200000 - Main</b>				
Account <b>52110 - Office Supplies</b>				
5819 - Synchrony Bank	20-Wireless mouse for laptop (VanDeventer & Bitner)	01/24/2023	02/03/2023	39.98



# Board of Public Works Claim Register

Invoice Date Range 01/21/23 - 02/03/23

**Account 52210 - Institutional Supplies**

313 - Fastenal Company	20-Safety Supplies for Crews (gloves, glasses, ear plugs)	01/24/2023	02/03/2023	297.52
313 - Fastenal Company	20-Safety Supplies for Crews (gloves, glasses, ear plugs)	01/24/2023	02/03/2023	130.50

Account **52110 - Office Supplies** Totals 1 \$39.98

Account **52210 - Institutional Supplies** Totals 2 \$428.02

**Account 52340 - Other Repairs and Maintenance**

294 - All-Phase Electric Supply, INC	20-Misc supplies for traffic signal repairs	01/24/2023	02/03/2023	20.49
796 - Interstate Battery System of Bloomington, INC	20-Batteries for RFB at Washington & Smith Ave	01/24/2023	02/03/2023	356.10
4519 - Osburn Associates, INC	20-No Parking Symbol Signs	01/24/2023	02/03/2023	117.20

Account **52340 - Other Repairs and Maintenance** Totals 3 \$493.79

**Account 52420 - Other Supplies**

409 - Black Lumber Co. INC	20-Misc Supplies for crews-security bit	01/24/2023	02/03/2023	2.58
409 - Black Lumber Co. INC	20-Misc Supplies for crews-quickcrete, adhesive	01/24/2023	02/03/2023	38.51
409 - Black Lumber Co. INC	20-Misc Supplies for crews	01/24/2023	02/03/2023	128.64
409 - Black Lumber Co. INC	20-Misc Supplies for crews	01/24/2023	02/03/2023	9.48
455 - Industrial Service & Supply, INC	20-Supplies for brine tank (remove ends, clamp)	01/24/2023	02/03/2023	130.64
455 - Industrial Service & Supply, INC	20-Supplies for brine tank (spool adaptor)	01/24/2023	02/03/2023	18.37
4574 - John Deere Financial f.s.b. (Rural King)	20-Wheelspinners deluxe knob for units #425, #432)	01/24/2023	02/03/2023	27.98
4574 - John Deere Financial f.s.b. (Rural King)	20-Supplies for brine tank (couplings)	01/24/2023	02/03/2023	173.87
4574 - John Deere Financial f.s.b. (Rural King)	20-Supplies for brine tank (couplings & fittings)	01/24/2023	02/03/2023	76.96
394 - Kleindorfer Hardware & Variety	20-Misc Supplies for crews	01/24/2023	02/03/2023	33.47
394 - Kleindorfer Hardware & Variety	20-Misc Supplies for crews	01/24/2023	02/03/2023	47.70
394 - Kleindorfer Hardware & Variety	20-Misc Supplies for crews	01/24/2023	02/03/2023	12.98
394 - Kleindorfer Hardware & Variety	20-Misc Supplies for crews	01/24/2023	02/03/2023	15.38
394 - Kleindorfer Hardware & Variety	20-Misc Supplies for crews	01/24/2023	02/03/2023	42.56
394 - Kleindorfer Hardware & Variety	20-Misc Supplies for crews	01/24/2023	02/03/2023	84.83

Account **52420 - Other Supplies** Totals 15 \$843.95

**Account 53130 - Medical**

231 - IU Health OCC Health Services	20-K. Larsh-DS DOT 5 Panel E Screen-12/16/22	01/24/2023	02/03/2023	50.00
-------------------------------------	--	------------	------------	-------

Account **53130 - Medical** Totals 1 \$50.00

**Account 53150 - Communications Contract**



# Board of Public Works Claim Register

Invoice Date Range 01/21/23 - 02/03/23

5465 - Emergency Radio Service LLC (ERS-OCI Wireless)	20-Monthly Two-way Radio Services for Vehicles-Dec 2022	01/24/2023	02/03/2023	2,321.25
5465 - Emergency Radio Service LLC (ERS-OCI Wireless)	20-Monthly Two-way Radio Services for Vehicles-Jan 2023	01/24/2023	02/03/2023	2,321.25
Account <b>53150 - Communications Contract</b> Totals			2	\$4,642.50
<b>Account 53250 - Pagers</b>				
332 - Indiana Paging Network, INC	20-Monthly Service for Pagers (Snow Control)-Feb 2023	01/24/2023	02/03/2023	86.14
Account <b>53250 - Pagers</b> Totals			1	\$86.14
<b>Account 53540 - Natural Gas</b>				
6769 - EDF, INC (EDF Energy Services)	06-City Fac.-Natural Gas Commodity-Dec 2022 management fee	01/25/2023	01/25/2023	228.13
222 - Indiana Gas Co. INC (CenterPoint Energy) (Vectren)	20-Street Dept-gas bill 11/4-12/5/22	01/25/2023	01/25/2023	156.57
222 - Indiana Gas Co. INC (CenterPoint Energy) (Vectren)	20-Street Dept-gas bill 12/5/22-1/5/23	01/25/2023	01/25/2023	231.98
222 - Indiana Gas Co. INC (CenterPoint Energy) (Vectren)	20-Traffic bldg-gas bill 12/5/22-01/5/22	01/25/2023	01/25/2023	169.40
222 - Indiana Gas Co. INC (CenterPoint Energy) (Vectren)	20-Traffic Bldg-gas bill 11/4-12/5/22	01/25/2023	01/25/2023	113.33
Account <b>53540 - Natural Gas</b> Totals			5	\$899.41
<b>Account 53990 - Other Services and Charges</b>				
17528 - Jason R Hollers (Hollers Welding)	20-Welding repair for handrail on Rogers Rd	01/24/2023	02/03/2023	4,200.00
902 - Indiana Underground Plant Protection Service, INC	20-IN 811-Line Locate Services for December 2022	01/24/2023	02/03/2023	640.30
19444 - Jeffery D Todd (Todd Septic Tank Service)	20-pump saltwater collection tanks-12/15/22	01/24/2023	02/03/2023	200.00
Account <b>53990 - Other Services and Charges</b> Totals			3	\$5,040.30
Program <b>200000 - Main</b> Totals			33	\$12,524.09
Department <b>20 - Street</b> Totals			33	\$12,524.09
Fund <b>451 - Motor Vehicle Highway(S0708)</b> Totals			33	\$12,524.09
<b>Fund 452 - Parking Facilities(S9502)</b>				
Department <b>26 - Parking</b>				
Program <b>260000 - Main</b>				
<b>Account 53510 - Electrical Services</b>				
223 - Duke Energy	26-4th St Garage-105 W 4th -elec chgs 11/29-12/28/22	01/25/2023	01/25/2023	517.85
Account <b>53510 - Electrical Services</b> Totals			1	\$517.85
<b>Account 53530 - Water and Sewer</b>				
208 - City Of Bloomington Utilities	26-4th St Garage-water/sewer bill- Dec 2022	01/25/2023	01/25/2023	115.55
Account <b>53530 - Water and Sewer</b> Totals			1	\$115.55
<b>Account 53540 - Natural Gas</b>				



# Board of Public Works Claim Register

Invoice Date Range 01/21/23 - 02/03/23

7854 - Premier AG CO-OP, INC (Premier Energy)	26-Natural Gas for Trades Garage-335 gallons-12/21/22	01/24/2023		02/03/2023	1,121.92	
Account <b>53540 - Natural Gas</b> Totals					1	\$1,121.92
<b>Account 53610 - Building Repairs</b>						
392 - Koorsen Fire & Security, INC	19- SA-Repair Water Lines after Freeze@ Trades Garage	01/24/2023	BC 2022-16	02/03/2023	788.80	
392 - Koorsen Fire & Security, INC	26-Fire Monitoring @ Morton Street Garage	01/24/2023	BC 2022-92	02/03/2023	272.95	
Account <b>53610 - Building Repairs</b> Totals					2	\$1,061.75
<b>Account 53650 - Other Repairs</b>						
3397 - Evens Time, INC	26-Additional Services Beyond Scope of SA, Meters	01/24/2023		02/03/2023	562.99	
Account <b>53650 - Other Repairs</b> Totals					1	\$562.99
<b>Account 53990 - Other Services and Charges</b>						
6330 - Marshall Security LLC	26- Contract for Patrol of Garages-12/1-12/31/22	01/24/2023	BC 2022-11	02/03/2023	3,968.00	
6330 - Marshall Security LLC	26- Contract for Patrol of Garages-10/1-10/31/22	01/24/2023	BC 2022-11	02/03/2023	3,968.00	
Account <b>53990 - Other Services and Charges</b> Totals					2	\$7,936.00
Program <b>260000 - Main</b> Totals					8	\$11,316.06
Department <b>26 - Parking</b> Totals					8	\$11,316.06
Fund <b>452 - Parking Facilities(S9502)</b> Totals					8	\$11,316.06
<b>Fund 454 - Alternative Transport(S6301)</b>						
Department <b>05 - Common Council</b>						
Program <b>050000 - Main</b>						
<b>Account 54310 - Improvements Other Than Building</b>						
10 - Bledsoe Riggert Cooper & James INC	07-Liberty Sidewalk Assessment & Preliminary design	01/24/2023		02/03/2023	372.00	
10 - Bledsoe Riggert Cooper & James INC	07-Liberty Sidewalk Design Services-11/30/22	01/24/2023		02/03/2023	2,188.80	
467 - Groomer Construction, INC	07-Dunn St SW 15-16th (CN) 07/12/22-12/23/22	01/24/2023	BC 2022-42	02/03/2023	213,478.55	
Account <b>54310 - Improvements Other Than Building</b> Totals					3	\$216,039.35
Program <b>050000 - Main</b> Totals					3	\$216,039.35
Department <b>05 - Common Council</b> Totals					3	\$216,039.35
Department <b>13 - Planning</b>						
Program <b>130000 - Main</b>						
<b>Account 54310 - Improvements Other Than Building</b>						
7059 - Eagle Ridge Civil Engineering Services, LLC	13-Misc. Neighborhood Greenways-Inv date 12/23/22	01/24/2023	BC 2022-135	02/03/2023	1,018.20	
Account <b>54310 - Improvements Other Than Building</b> Totals					1	\$1,018.20
Program <b>130000 - Main</b> Totals					1	\$1,018.20
Department <b>13 - Planning</b> Totals					1	\$1,018.20
Fund <b>454 - Alternative Transport(S6301)</b> Totals					4	\$217,057.55





# Board of Public Works Claim Register

Invoice Date Range 01/21/23 - 02/03/23

**Fund 455 - Parking Meter Fund(S2141)**

Department **26 - Parking**

Program **260000 - Main**

Account **53410 - Liability / Casualty Premiums**

19618 - ONI Risk Partners, INC, DBA EPIC	10-CL Excess Work Comp 01/01/23-01/01/24	01/25/2023		01/25/2023	907.63
Insurance Midwest					
19618 - ONI Risk Partners, INC, DBA EPIC	10-Surplus Lines Tax-CL Excess Work Comp 1/1/23-1/1/24	01/25/2023		01/25/2023	22.70
Insurance Midwest					
19618 - ONI Risk Partners, INC, DBA EPIC	10-Renewal CL Package 01/01/23-01/01/24	01/25/2023		01/25/2023	2,687.90
Insurance Midwest					
Account <b>53410 - Liability / Casualty Premiums</b> Totals				3	\$3,618.23

Account **53990 - Other Services and Charges**

6330 - Marshall Security LLC	26-11/2/2022 temp servies for covering school crossings	01/24/2023	BC 2022-78	02/03/2023	2,100.00
Account <b>53990 - Other Services and Charges</b> Totals				1	\$2,100.00
Program <b>260000 - Main</b> Totals				4	\$5,718.23
Department <b>26 - Parking</b> Totals				4	\$5,718.23
Fund <b>455 - Parking Meter Fund(S2141)</b> Totals				4	\$5,718.23

**Fund 456 - MVH Restricted**

Department **20 - Street**

Program **200000 - Main**

Account **52420 - Other Supplies**

6222 - Apple, INC	20-Smart keyboard for Ipad (Lucity)	01/24/2023		02/03/2023	298.00
Account <b>52420 - Other Supplies</b> Totals				1	\$298.00

Account **53990 - Other Services and Charges**

7905 - IMS Infrastructure Management Services, LLC	20-Asset management data collection services-11/30/22	01/24/2023	BC 2021-81	02/03/2023	46,500.45
Account <b>53990 - Other Services and Charges</b> Totals				1	\$46,500.45

Account **54510 - Other Capital Outlays**

5149 - E&B Paving, INC	20-CCMG 2022-1 Smith Road Proj Des#220227-10/6-11/23/22-App 2	01/24/2023	BC 2022-43	02/03/2023	71,684.83
5149 - E&B Paving, INC	20-CCMG 2022-1 Smith Road Proj Des#220227-11/24/22-1/09/23-App 3	01/24/2023	BC 2022-43	02/03/2023	1,641.60
Account <b>54510 - Other Capital Outlays</b> Totals				2	\$73,326.43
Program <b>200000 - Main</b> Totals				4	\$120,124.88
Department <b>20 - Street</b> Totals				4	\$120,124.88
Fund <b>456 - MVH Restricted</b> Totals				4	\$120,124.88

**Fund 521 - 2017 Refund 517 2011 DT Red Bond**

Department **06 - Controller's Office**

Program **060000 - Main**

Account **53810 - Principal**

18844 - First Financial Bank, N.A.	06-Refunding Downtown Redev. Bond of 2011-2/1/23	01/23/2023		01/23/2023	345,000.00
------------------------------------	--	------------	--	------------	------------



# Board of Public Works Claim Register

Invoice Date Range 01/21/23 - 02/03/23

Account **53820 - Interest**  
18844 - First Financial Bank, N.A.

06-Refunding Downtown Redev. Bond of 2011-2/1/23

Account <b>53810 - Principal</b> Totals	1		\$345,000.00
		01/23/2023	106,479.39
Account <b>53820 - Interest</b> Totals	1		\$106,479.39
Program <b>060000 - Main</b> Totals	2		\$451,479.39
Department <b>06 - Controller's Office</b> Totals	2		\$451,479.39
Fund <b>521 - 2017 Refund 517 2011 DT Red Bond</b> Totals	2		\$451,479.39

Fund **523 - 2019 4th St Garage (S)**  
Department **06 - Controller's Office**  
Program **060000 - Main**  
Account **53820 - Interest**  
4740 - Bank Of New York

06-Bloomington RD TIRB 2019A-1-Feb 2023

		01/23/2023	319,762.50
Account <b>53820 - Interest</b> Totals	1		\$319,762.50
Program <b>060000 - Main</b> Totals	1		\$319,762.50
Department <b>06 - Controller's Office</b> Totals	1		\$319,762.50
Fund <b>523 - 2019 4th St Garage (S)</b> Totals	1		\$319,762.50

Fund **524 - 2019 4th St Garage Tax (S)**  
Department **06 - Controller's Office**  
Program **060000 - Main**  
Account **53810 - Principal**  
4740 - Bank Of New York

06-IN Redev Taxable Revenue Bond-BLOOMTAX19A2-Feb 2023

		01/23/2023	565,000.00
Account <b>53810 - Principal</b> Totals	1		\$565,000.00

Account **53820 - Interest**  
4740 - Bank Of New York

06-IN Redev Taxable Revenue Bond-BLOOMTAX19A2-Feb 2023

		01/23/2023	26,700.00
Account <b>53820 - Interest</b> Totals	1		\$26,700.00
Program <b>060000 - Main</b> Totals	2		\$591,700.00
Department <b>06 - Controller's Office</b> Totals	2		\$591,700.00
Fund <b>524 - 2019 4th St Garage Tax (S)</b> Totals	2		\$591,700.00

Fund **525 - 2019 Trades Garage (S)**  
Department **06 - Controller's Office**  
Program **060000 - Main**  
Account **53820 - Interest**  
4740 - Bank Of New York

06-Bloomington RD TIRB 2019B-Feb 2023

		01/23/2023	268,412.50
Account <b>53820 - Interest</b> Totals	1		\$268,412.50
Program <b>060000 - Main</b> Totals	1		\$268,412.50
Department <b>06 - Controller's Office</b> Totals	1		\$268,412.50



# Board of Public Works Claim Register

Invoice Date Range 01/21/23 - 02/03/23

		Fund 525 - 2019 Trades Garage (S ) Totals	1		\$268,412.50
<b>Fund 601 - Cumulative Capital Devlp(S2391)</b>					
Department 02 - Public Works					
Program 020000 - Main					
Account 52330 - Street , Alley, and Sewer Material					
19278 - Milestone Contractors, LP	20-Cold MlX Asphalt	01/24/2023		02/03/2023	4,308.00
351 - Young Trucking, INC	20-Clear Lane De-icing Salt	01/24/2023		02/03/2023	32,160.00
Account 52330 - Street , Alley, and Sewer Material Totals				2	\$36,468.00
<b>Account 52420 - Other Supplies</b>					
4519 - Osburn Associates, INC	20-20-Zephyr Sigh Stands	01/24/2023		02/03/2023	828.00
5819 - Synchrony Bank	20-Eagle 1732Gn Ribbed Bumper Sleeve for Post on Kirkwood	01/24/2023		02/03/2023	297.38
603 - Traffic Control Corporation	20-Prempt/Proir Applied Information Signals on College Mall Rd	01/24/2023		02/03/2023	48,367.00
Account 52420 - Other Supplies Totals				3	\$49,492.38
<b>Account 54420 - Purchase of Equipment</b>					
786 - Richard's Small Engine, INC	20-60" 40HPVanguard EFI OGS Mower (BB Contract #611-20)	01/24/2023		02/03/2023	11,712.74
Account 54420 - Purchase of Equipment Totals				1	\$11,712.74
<b>Account 54510 - Other Capital Outlays</b>					
5149 - E&B Paving, INC	20-CCMG 2022-1 Smith Road Proj Des#220227-10/6-11/23/22-App 2	01/24/2023	BC 2021-119	02/03/2023	113,306.08
18844 - First Financial Bank, N.A.	20-CCMG 2022-1 Smith Road Proj Des#220227-10/6-11/23/22-Esc 2	01/24/2023		02/03/2023	9,852.54
18844 - First Financial Bank, N.A.	20-CCMG 2022-1 Smith Rd Proj Des#220227-11/24/22-01/09/23-Esc 3	01/24/2023		02/03/2023	86.40
Account 54510 - Other Capital Outlays Totals				3	\$123,245.02
Program 020000 - Main Totals				9	\$220,918.14
Department 02 - Public Works Totals				9	\$220,918.14
Fund 601 - Cumulative Capital Devlp(S2391) Totals				9	\$220,918.14
<b>Fund 730 - Solid Waste (S6401)</b>					
Department 16 - Sanitation					
Program 160000 - Main					
Account 53240 - Freight / Other					
8511 - AaquaTools, INC	16-Freight & shipping for sanitation cart cleaning system	01/24/2023		02/03/2023	295.00
Account 53240 - Freight / Other Totals				1	\$295.00
<b>Account 53410 - Liability / Casualty Premiums</b>					
19618 - ONI Risk Partners, INC, DBA EPIC	10-CL Excess Work Comp 01/01/23-01/01/24	01/25/2023		01/25/2023	2,542.43
19618 - ONI Risk Partners, INC, DBA EPIC	10-Surplus Lines Tax-CL Excess Work Comp 1/1/23-1/1/24	01/25/2023		01/25/2023	63.59
19618 - ONI Risk Partners, INC, DBA EPIC	10-Renewal CL Package 01/01/23-01/01/24	01/25/2023		01/25/2023	54,717.82



# Board of Public Works Claim Register

Invoice Date Range 01/21/23 - 02/03/23

		Account <b>53410 - Liability / Casualty Premiums</b> Totals	3		<u>\$57,323.84</u>
Account <b>53540 - Natural Gas</b>					
6769 - EDF, INC (EDF Energy Services)	06-City Fac.-Natural Gas Commodity-Dec 2022 management fee	01/25/2023	01/25/2023		242.10
222 - Indiana Gas Co. INC (CenterPoint Energy) (Vectren)	16-Sanitation-gas bill 11/2-12/2/22	01/25/2023	01/25/2023		304.35
		Account <b>53540 - Natural Gas</b> Totals	2		<u>\$546.45</u>
Account <b>53920 - Laundry and Other Sanitation Services</b>					
19171 - Aramark Uniform & Career Apparel Group, INC	16-uniform laundry Services - 1-4-2023	01/24/2023	02/03/2023		4.62
19171 - Aramark Uniform & Career Apparel Group, INC	16-uniform Laundry Services - 1-11-2023	01/24/2023	02/03/2023		4.62
19171 - Aramark Uniform & Career Apparel Group, INC	16-uniform Laundry Services - 1-18-2023	01/24/2023	02/03/2023		4.62
19171 - Aramark Uniform & Career Apparel Group, INC	16-mat service-01/04/2023	01/24/2023	02/03/2023		23.26
19171 - Aramark Uniform & Career Apparel Group, INC	16-Mat Services - 01/11/2023	01/24/2023	02/03/2023		23.26
19171 - Aramark Uniform & Career Apparel Group, INC	16-Mat Services - 01/18/2023	01/24/2023	02/03/2023		23.26
		Account <b>53920 - Laundry and Other Sanitation Services</b> Totals	6		<u>\$83.64</u>
Account <b>53950 - Landfill</b>					
52226 - Hoosier Transfer Station-3140	16-trash disposal fee-01/02-01/14/23	01/24/2023	02/03/2023		15,801.52
52226 - Hoosier Transfer Station-3140	16-recycling fees-01/02-01/12/2023	01/24/2023	02/03/2023		2,886.22
		Account <b>53950 - Landfill</b> Totals	2		<u>\$18,687.74</u>
Account <b>53990 - Other Services and Charges</b>					
392 - Koorsen Fire & Security, INC	16-Fire Extinguisher Services	01/24/2023	BC 2022-92 02/03/2023		159.00
476 - Southern Indiana Parts, INC (Napa Auto Parts)	16-fuel filter & cleaning product for power washer	01/24/2023	02/03/2023		59.98
		Account <b>53990 - Other Services and Charges</b> Totals	2		<u>\$218.98</u>
		Program <b>160000 - Main</b> Totals	16		<u>\$77,155.65</u>
		Department <b>16 - Sanitation</b> Totals	16		<u>\$77,155.65</u>
		Fund <b>730 - Solid Waste (S6401)</b> Totals	16		<u>\$77,155.65</u>
Fund <b>800 - Risk Management(S0203)</b>					
Department <b>10 - Legal</b>					
Program <b>100000 - Main</b>					
Account <b>53410 - Liability / Casualty Premiums</b>					
19618 - ONI Risk Partners, INC, DBA EPIC Insurance Midwest	10-CL Excess Work Comp 01/01/23-01/01/24	01/25/2023	01/25/2023		68.62
19618 - ONI Risk Partners, INC, DBA EPIC Insurance Midwest	10-Surplus Lines Tax-CL Excess Work Comp 1/1/23-1/1/24	01/25/2023	01/25/2023		1.72





# Board of Public Works Claim Register

Invoice Date Range 01/21/23 - 02/03/23

19618 - ONI Risk Partners, INC, DBA EPIC Insurance Midwest	10-Renewal CL Package 01/01/23-01/01/24	01/25/2023	01/25/2023	753.32
Account <b>53410 - Liability / Casualty Premiums</b> Totals			3	<u>\$823.66</u>
Account <b>53990 - Other Services and Charges</b>				
4878 - James M Smith	10-CDL training Smith	01/24/2023	02/03/2023	500.00
204 - State Of Indiana	10-drivers lic lookup on website	01/24/2023	02/03/2023	95.00
Account <b>53990 - Other Services and Charges</b> Totals			2	<u>\$595.00</u>
Program <b>100000 - Main</b> Totals			5	<u>\$1,418.66</u>
Department <b>10 - Legal</b> Totals			5	<u>\$1,418.66</u>
Fund <b>800 - Risk Management(S0203)</b> Totals			5	<u>\$1,418.66</u>
Fund <b>801 - Health Insurance Trust</b>				
Department <b>12 - Human Resources</b>				
Program <b>120000 - Main</b>				
Account <b>53990.1201 - Other Services and Charges Health Insurance</b>				
17785 - The Howard E. Nyhart Company, INC	12-January 2023 Wellness Reimbursements	01/24/2023	01/24/2023	22,983.96
3908 - CIGNA Healthcare	12-January 2023 Cigna Dental Funding	01/26/2023		36,956.00
Account <b>53990.1201 - Other Services and Charges Health Insurance</b> Totals			2	<u>\$59,939.96</u>
Program <b>120000 - Main</b> Totals			2	<u>\$59,939.96</u>
Department <b>12 - Human Resources</b> Totals			2	<u>\$59,939.96</u>
Fund <b>801 - Health Insurance Trust</b> Totals			2	<u>\$59,939.96</u>
Fund <b>802 - Fleet Maintenance(S9500)</b>				
Department <b>17 - Fleet Maintenance</b>				
Program <b>170000 - Main</b>				
Account <b>52230 - Garage and Motor Supplies</b>				
50605 - Bauer Built, INC	17 - Disposal of 9 Light weight truck tires	01/24/2023	02/03/2023	45.00
50605 - Bauer Built, INC	17 - Disposal Fee-1 Commercial and 9 light weight Truck tires	01/24/2023	02/03/2023	57.75
4693 - Monroe County Tire & Supply, INC	17-service call,tire repair on 656 put in short brass valve in	01/24/2023	02/03/2023	83.25
4693 - Monroe County Tire & Supply, INC	17 - Tire repair on LF on Loader 456, 25" O'ring & stem valve	01/24/2023	02/03/2023	159.22
4693 - Monroe County Tire & Supply, INC	17 - 4 P255/70R17 Yokohama GEO A/T G015 owl tires	01/24/2023	02/03/2023	781.00
4693 - Monroe County Tire & Supply, INC	17 -2 Titan IND Trac Lug 12ply, valve stem, tire disposal fee&SC	01/24/2023	02/03/2023	1,539.25
Account <b>52230 - Garage and Motor Supplies</b> Totals			6	<u>\$2,665.47</u>
Account <b>52240 - Fuel and Oil</b>				
7854 - Premier AG CO-OP, INC (Premier Energy)	17 - diesel fuel B5 PDX4 - 7,342 gallons-1/6/23	01/24/2023	02/03/2023	25,903.31
7854 - Premier AG CO-OP, INC (Premier Energy)	17 - unleaded fuel - 8,091 gallons-01/10/2023	01/24/2023	02/03/2023	28,078.20



# Board of Public Works Claim Register

Invoice Date Range 01/21/23 - 02/03/23

7854 - Premier AG CO-OP, INC (Premier Energy)	17 - diesel fuel PDX4 B5 - 7,351 gallons-1-12-2023	01/24/2023	02/03/2023	28,378.54
Account <b>52320 - Motor Vehicle Repair</b>				
4150 - Alexander's LLC	17 - 878 light	01/24/2023	02/03/2023	6.75
4135 - Andy Mohr Truck Center	17 - Sensor & Harness for 959	01/24/2023	02/03/2023	937.31
244 - Bloomington Ford, INC	17 - various parts - oil Switch assembly	01/24/2023	02/03/2023	29.61
244 - Bloomington Ford, INC	17 - various parts - stop switch assembly	01/24/2023	02/03/2023	43.23
244 - Bloomington Ford, INC	17- 252- OSLSS oil change	01/24/2023	02/03/2023	29.83
244 - Bloomington Ford, INC	17 - OSLSS #542 oil change	01/24/2023	02/03/2023	114.07
244 - Bloomington Ford, INC	17 - OSLSS #577 oil change and rear brakes	01/24/2023	02/03/2023	150.01
244 - Bloomington Ford, INC	17 - 1228 OSL Water pump and coolant issues	01/24/2023	02/03/2023	3,217.70
941 - Central Indiana Truck Equipment Corporation	17 - Air Actuator	01/24/2023	02/03/2023	4,475.76
51827 - Fire Service, INC	17 - #394 radiator cap and over fill cap	01/24/2023	02/03/2023	101.92
51827 - Fire Service, INC	17 - Belt Tensioner & Tensioner for stock	01/24/2023	02/03/2023	826.30
4992 - Fleetpride, INC	17 - #955 fuel filter	01/24/2023	02/03/2023	51.71
455 - Industrial Service & Supply, INC	17 - 1/2 steel Ferrule air brake, J/C Swivel female, crimp charge	01/24/2023	02/03/2023	18.85
796 - Interstate Battery System of Bloomington, INC	17 - battery for City vehicle 291	01/24/2023	02/03/2023	131.51
4439 - JX Enterprises, INC	17 - Driveline - Center support Bearing	01/24/2023	02/03/2023	127.99
394 - Kleindorfer Hardware & Variety	17 - misc hardware - 1/2 BR ST 90 degree & 1/2 CLO BR nipple	01/24/2023	02/03/2023	10.18
53385 - O'Reilly Automotive Stores, INC	17 - various parts - LD Air	01/24/2023	02/03/2023	18.71
53385 - O'Reilly Automotive Stores, INC	17 - Fuel Filter	01/24/2023	02/03/2023	31.50
53385 - O'Reilly Automotive Stores, INC	17 - various parts - EGR valve & Cooler	01/24/2023	02/03/2023	576.48
337 - Stansifer Radio Co, INC	17 - (2)Battery connection kit, (30) ea of black & Red wires.	01/24/2023	02/03/2023	136.72
54351 - Sternberg, INC	17 - fan belt	01/24/2023	02/03/2023	57.89
54351 - Sternberg, INC	17 - Strap kit	01/24/2023	02/03/2023	66.90
54351 - Sternberg, INC	17 - Fuel filter/water separator	01/24/2023	02/03/2023	67.67
54351 - Sternberg, INC	17 - Valve inversion	01/24/2023	02/03/2023	332.95
582 - Town & Country Chrysler Dodge Jeep, INC	17 - Antenna	01/24/2023	02/03/2023	9.35
582 - Town & Country Chrysler Dodge Jeep, INC	17 - Engine Coolant for radiator	01/24/2023	02/03/2023	510.00
582 - Town & Country Chrysler Dodge Jeep, INC	17 - Engine Coolant radiator (2)	01/24/2023	02/03/2023	1,020.00
			Account <b>52240 - Fuel and Oil Totals</b>	3
				<u>\$82,360.05</u>



# Board of Public Works Claim Register

Invoice Date Range 01/21/23 - 02/03/23

582 - Town & Country Chrysler Dodge Jeep, INC	17 - Anti-lock Brake sensor	01/24/2023	02/03/2023	66.30
582 - Town & Country Chrysler Dodge Jeep, INC	17 - Ignition coil	01/24/2023	02/03/2023	125.80
622 - Truck Country of Indiana, INC (Stoops Freightliner	17 - Fan speed module	01/24/2023	02/03/2023	113.19
622 - Truck Country of Indiana, INC (Stoops Freightliner	17 - Hvac fan motor ACMD	01/24/2023	02/03/2023	576.44
7555 - VoMac Truck Sales & Service INC	17 - Fuel filter	01/24/2023	02/03/2023	27.11
8183 - XL Parts LLC (XL Parts/Dealer Service Warehouse)	17 - Brake lining kit	01/24/2023	02/03/2023	63.24
8183 - XL Parts LLC (XL Parts/Dealer Service Warehouse)	17 - credit - return Motor starter assembly	01/24/2023	02/03/2023	(16.50)
8183 - XL Parts LLC (XL Parts/Dealer Service Warehouse)	17 - 1qt of mercon LV	01/24/2023	02/03/2023	90.96
8183 - XL Parts LLC (XL Parts/Dealer Service Warehouse)	17 - Tensioner & Serpentine Belt	01/24/2023	02/03/2023	97.07
8183 - XL Parts LLC (XL Parts/Dealer Service Warehouse)	17 - Interceptor	01/24/2023	02/03/2023	147.21
<b>Account 52320 - Motor Vehicle Repair Totals</b>			37	\$14,391.72
<b>Account 52420 - Other Supplies</b>				
409 - Black Lumber Co. INC	17 - (8) 3/4" brass Cup hooks	01/24/2023	02/03/2023	15.92
177 - Indiana Oxygen Company, INC	17 - gases for torch and welding equipment	01/24/2023	02/03/2023	260.58
<b>Account 52420 - Other Supplies Totals</b>			2	\$276.50
<b>Account 53410 - Liability / Casualty Premiums</b>				
19618 - ONI Risk Partners, INC, DBA EPIC Insurance Midwest	10-CL Excess Work Comp 01/01/23-01/01/24	01/25/2023	01/25/2023	823.59
19618 - ONI Risk Partners, INC, DBA EPIC Insurance Midwest	10-Surplus Lines Tax-CL Excess Work Comp 1/1/23-1/1/24	01/25/2023	01/25/2023	20.60
19618 - ONI Risk Partners, INC, DBA EPIC Insurance Midwest	10-Renewal CL Package 01/01/23-01/01/24	01/25/2023	01/25/2023	4,320.58
<b>Account 53410 - Liability / Casualty Premiums Totals</b>			3	\$5,164.77
<b>Account 53540 - Natural Gas</b>				
6769 - EDF, INC (EDF Energy Services)	06-City Fac.-Natural Gas Commodity-Dec 2022 management fee	01/25/2023	01/25/2023	164.08
222 - Indiana Gas Co. INC (CenterPoint Energy) (Vectren)	17-Fleet Maint-gas bill 12/5/22-1/5/23	01/25/2023	01/25/2023	385.87
222 - Indiana Gas Co. INC (CenterPoint Energy) (Vectren)	17-Fleet Maint-gas bill 11/4-12/5/22	01/25/2023	01/25/2023	210.23
<b>Account 53540 - Natural Gas Totals</b>			3	\$760.18
<b>Account 53620 - Motor Repairs</b>				
244 - Bloomington Ford, INC	17- 252- OSLSS oil change	01/24/2023	02/03/2023	28.00



# Board of Public Works Claim Register

Invoice Date Range 01/21/23 - 02/03/23

244 - Bloomington Ford, INC	17 - OSLSS #542 oil change	01/24/2023	02/03/2023	28.00
244 - Bloomington Ford, INC	17 - OSLSS #577 oil change and rear brakes	01/24/2023	02/03/2023	203.11
4474 - Ken's Westside Service & Towing, LLC	17-towing-Unit 126 Ford Explorer-1/4/23	01/24/2023	02/03/2023	75.00
4474 - Ken's Westside Service & Towing, LLC	17-towing-International workstar 7400 truck loaded w/stone-1/3	01/24/2023	02/03/2023	287.50
Account <b>53620 - Motor Repairs</b> Totals			5	\$621.61
<b>Account 53920 - Laundry and Other Sanitation Services</b>				
19171 - Aramark Uniform & Career Apparel Group, INC	17 - Mat and towel rentals - 1/4/2023	01/24/2023	02/03/2023	77.36
19171 - Aramark Uniform & Career Apparel Group, INC	17 - City portion of uniform rentals - 1/4/2023	01/24/2023	02/03/2023	18.84
19171 - Aramark Uniform & Career Apparel Group, INC	17 - Mat and towel rentals - 1/11/2023	01/24/2023	02/03/2023	77.36
19171 - Aramark Uniform & Career Apparel Group, INC	17 - City portion Of uniform rentals - 1/11/2023	01/24/2023	02/03/2023	16.47
Account <b>53920 - Laundry and Other Sanitation Services</b> Totals			4	\$190.03
Program <b>170000 - Main</b> Totals			63	\$106,430.33
Department <b>17 - Fleet Maintenance</b> Totals			63	\$106,430.33
Fund <b>802 - Fleet Maintenance(\$9500)</b> Totals			63	\$106,430.33
<b>Fund 804 - Insurance Voluntary Trust</b>				
<b>Department 12 - Human Resources</b>				
<b>Program 120000 - Main</b>				
<b>Account 53990.1271 - Other Services and Charges Section 125 - URM- City</b>				
17785 - The Howard E. Nyhart Company, INC	12-City URM	01/23/2023	01/23/2023	78.94
17785 - The Howard E. Nyhart Company, INC	12-City URM	01/23/2023	01/23/2023	2,528.61
17785 - The Howard E. Nyhart Company, INC	12-City URM	01/23/2023	01/23/2023	118.93
17785 - The Howard E. Nyhart Company, INC	12-City URM	01/24/2023	01/24/2023	110.99
17785 - The Howard E. Nyhart Company, INC	12-City/Util URM	01/25/2023	01/25/2023	279.98
17785 - The Howard E. Nyhart Company, INC	12-City/Util URM	01/26/2023		385.04
Account <b>53990.1271 - Other Services and Charges Section 125 - URM- City</b> Totals			6	\$3,502.49
<b>Account 53990.1281 - Other Services and Charges Section 125 - URM- Util</b>				
17785 - The Howard E. Nyhart Company, INC	12-City/Util URM	01/25/2023	01/25/2023	19.95
17785 - The Howard E. Nyhart Company, INC	12-City/Util URM	01/26/2023		40.00





# Board of Public Works Claim Register

Invoice Date Range 01/21/23 - 02/03/23

Account <b>53990.1281 - Other Services and Charges Section 125 - URM- Util</b> Totals		2		\$59.95
Account <b>53990.1283 - Other Services and Charges Health Savings Account</b>				
17785 - The Howard E. Nyhart Company, INC	12-Nyhart HSA Employee Contribution 1-27-2023		01/26/2023	24,251.45
Account <b>53990.1283 - Other Services and Charges Health Savings Account</b> Totals		1		\$24,251.45
Program <b>120000 - Main</b> Totals		9		\$27,813.89
Department <b>12 - Human Resources</b> Totals		9		\$27,813.89
Fund <b>804 - Insurance Voluntary Trust</b> Totals		9		\$27,813.89
Fund <b>978 - City 2016 GO Bond Proceeds</b>				
Department <b>06 - Controller's Office</b>				
Program <b>06016B - 2016 B Ped/Signal/Intersection</b>				
Account <b>54510 - Other Capital Outlays</b>				
5409 - VS Engineering, INC	13-Sare Road Trail Cl-thru 10/31/22		01/24/2023	268.80
			BC 2019-142	02/03/2023
Account <b>54510 - Other Capital Outlays</b> Totals		1		\$268.80
Program <b>06016B - 2016 B Ped/Signal/Intersection</b> Totals		1		\$268.80
Department <b>06 - Controller's Office</b> Totals		1		\$268.80
Fund <b>978 - City 2016 GO Bond Proceeds</b> Totals		1		\$268.80
		287		\$3,058,828.05

**REGISTER OF CLAIMS**  
**Board: Board of Public Works Claim Register**

Date:	Type of Claim	FUND	Description	Bank Transfer	Amount
02/03/23	Claims				\$3,058,828.05

\$3,058,828.05

**ALLOWANCE OF CLAIMS**

We have examined the claims listed on the foregoing register of claims, consisting of claims, and except for the claims not allowed as shown on the register, such claims are hereby allowed in the total amount of \$3,058,828.05

**Dated this 31st day of January year of 2023.**

\_\_\_\_\_  
 Kyla Cox Deckard, President

\_\_\_\_\_  
 Elizabeth Karon, Vice President

\_\_\_\_\_  
 Jennifer Lloyd, Secretary

I hereby certify that each of the above listed voucher(s) or bill(s) is (are) true and correct and I have audited same in accordance with IC 5-11-10-1.6.

Fiscal Office \_\_\_\_\_