

# **Board of Public Works Meeting**

## **February 28, 2023**



The City will offer virtual options, including CATS public access television (live and tape-delayed) and

Public comments and questions will be encouraged via Zoom or [bloomington.in.gov](http://bloomington.in.gov) rather than in person

**AGENDA**  
**BOARD OF PUBLIC WORKS**  
**February 28, 2023**

A Regular Meeting of the Board of Public Work will be held Tuesday, February 28, 2023 at 5:30 p.m. in the Council Chambers (Rm #115) of City Hall at the Showers Building, 401 N. Morton Street, Bloomington, Indiana and via Zoom by using the following link:

<https://bloomington.zoom.us/j/89418003555?pwd=bkpqZzY1ajN5aWRYOWVqSmh4clJpQT09>

Meeting ID: 894 1800 3555 Passcode: 435082

The City offers virtual options, including CATS public access television (live and tape- delayed). Comments and questions will be encouraged via Zoom or bloomington.in.gov rather than in person.

Auxiliary aids for people with disabilities are available upon request with adequate notice. Please call 812-349-3411 or email [public.works@bloomington.in.gov](mailto:public.works@bloomington.in.gov).

**I. MESSAGES FROM BOARD MEMBERS**

**II. PETITIONS AND REMONSTANCES**

1. Appeal Noise Citation # 40027 for 423 E. Southern Drive
2. Appeal Noise Citation #37913 for 437 E. 16<sup>th</sup> Street

**III. CONSENT AGENDA**

1. Approval of Minutes January 14, 2023
2. Bonding Agreement with Indiana University
3. Bonding Agreement with City of Bloomington Utilities
4. Resolution 2023-05; Declaration of Surplus Fleet Vehicles
5. Resolution 2023-08; Declaration of Surplus ITS
6. Revised 2023 Service Agreement with Precision Concrete, Inc. to Remove Sidewalk Trip Hazards
7. Approval of Payroll

**IV. NEW BUSINESS**

1. Memorandum of Understanding between Duke Energy and Parks & Recreation for the Reliability Project
2. Change Order #9 for the 7<sup>th</sup> Street Protected Bike Lane Project
3. Change Orders #1 and #2 for the 17<sup>th</sup> Street Multi-Use Path East Project
4. Contract with Bluestone Tree LLC for the B-Line Tree Clearing Project
5. Resolution 2023-10; Public Need to Purchase Right-of-Way for the Adams Street Sidewalk (Kirkwood to Fountain) Project
6. Request from AEG for Lane and Sidewalk Closures
7. Resolution 2023-09; IU Carnival

**V. STAFF REPORTS & OTHER BUSINESS**

**VI. APPROVAL OF CLAIMS**

**VII. ADJOURNMENT**



**STAFF REPORT**  
**NOV APPEAL (noise)**

---

**Appellant Information:**

Name: Marisol Sanchez  
Address: 423 E Southern Drive  
Bloomington, IN  
Date Appealed: February 10, 2023

**NOV Information:**

Date Issued: February 5, 2023  
By: Officer Dorman  
Where: 423 Southern Drive  
For: Unreasonable Noise

---

**Attachments:**

1. Notice of Violation
2. Dispatch Records
3. Noise Appeal
4. Proposed Order

**Controlling Ordinances and Language:**

**BMC § 14.09.030(c)(4).** It shall be a violation of this chapter to play, use, operate or allow to be played, used, or operated any radio, television, digital media player, loudspeaker, sound amplifier, musical instrument, or any other machine or device for producing or reproducing sound in such a manner that the sound produced persists continuously or intermittently for a period of at least fifteen minutes and can be heard outside the immediate premises from the location of the emitter by a person with normal hearing. *Sound that is clearly audible to a person with normal hearing from any place other than the premises from which the source of the sound is located, when the sound occurs between the hours of nine p.m. and seven a.m., is prima facie evidence of a violation of this section.* (emphasis added)

**BMC § 14.09.030(b).** Except as otherwise provided in this chapter, it shall be unlawful for any person to cause or make any unreasonable noise or to allow any unreasonable noise to be caused or made in or on any real or personal property occupied or controlled by that person.

**BMC § 14.09.070(b).** *Any person violating any of the provisions of this chapter, shall, upon a written finding of violation signed by the enforcement officer, be subject to an initial penalty of fifty dollars.* Each day such violation is committed or permitted to continue shall constitute a separate offense. A second violation in any twelve-month period is subject to a fine or penalty of one hundred dollars and subsequent violations within a twelve month period are subject to a fine or penalty of five hundred dollars. (emphasis added)

**Discussion:**

1. At approximately 11:45 p.m. on February 4, 2023, the Bloomington Police Department received a complaint regarding unreasonable noise at the property located at 423 E. Southern Drive (the "Property"). Officer Chad Dorman of the Bloomington Police Department, responded to the noise complaint and arrive on scene at approximately 12:27 a.m. on February 5, 2023.
2. Officer Dorman approached the Property and observed a large number of persons in the vicinity. While approaching the Property, but before entering the Property, Officer Dorman was able to clearly hear music and to identify that the sound was coming from the Property.
3. At 12:27 a.m. on February 5, 2023, Officer Dorman made contact with Marisol Sanchez ("Appellant") who is the/an occupant and tenant of the Property. Appellant was issued a ticket for unreasonable noise, and assessed a fine of \$50.
4. Appellant appealed the NOV.
5. The facts establish that the noise was unreasonable because it was audible from off premises between 9pm and 7am by Officer Dorman, a person with ordinary hearing.
6. Appellant occupies and has control of this property and is, therefore, a person who can and should be held responsible for this violation.
7. A fine of \$50 is appropriate because this is the first noise violation issued to Appellant and at this Property in a 12-month period

**Staff Recommendation:**

1. The appeal should be denied.

COUNTY OF MONROE  
CITY OF BLOOMINGTON  
ORDINANCE VIOLATION

NO. 400270

B23-05936

The undersigned having probable cause to believe and being duly sworn upon his/her oath says that on:

Day of Week Sun	Day 5	Month Feb	Year 2023	Time 0026
Last Name Sanchez		First Harised	ML E	
Street Address 423 E Southern Dr			DOB 6-11-01	
City Bloomington		State IN	Zip Code 47401	
Sex F	Race	SSN/OLN	[REDACTED]	

DID COMMIT THE FOLLOWING OFFENSE:

14-09.030

OR

Excessive Loud Noise

X

Residence

Vehicle

Contrary to the BMC §

14.09.030

at

Bloomington, IN.

Officer's Signature

[Signature]

I.D. No.

1707

City of Bloomington, Indiana

Date

2-5-23

Signature

[Signature]

Your signature is not an admission of guilt.

SEE OTHER SIDE FOR ADDITIONAL INFORMATION

02/24/23  
10:52

BLOOMINGTON POLICE DEPARTMENT  
CALL DETAIL REPORT

Page: 365  
1

Call Number: 230204272

Nature: NOISE  
Reported: 23:45:03 02/04/23  
Rcvd By: YATES N How Rcvd: 9  
Occ Btwn: 23:45:03 02/04/23 and 23:46:48 02/04/23  
Type: 1  
Priority: 4

Address: 432 E SOUTHERN DR  
City: BLOOMINGTON

Alarm:

COMPLAINANT/CONTACT

Complainant: , Name#:   
Race: Sex: DOB: \*\*/\*\*/\*\*  
Address: ,  
Home Phone: Work Phone:

Contact: JOHN  
Address: 1606 S ROGERS  
Phone: (432)888-4785

RADIO LOG

Dispatcher	Time/Date	Unit	Code	Zone	Agnc	Description
BRITTON E	00:09:00 02/05/23	1707	ER	LB3	BPD	(MDC) Enroute to a call incid#=B23-05936 call=2731
DORMAN C	00:09:06 02/05/23	1747	ENRT	LB3	BPD	(MDC) Assisting unit 1707 incid#=B23-05936 call=2731
BRITTON E	00:15:00 02/05/23	1707	AR	LB3	BPD	(MDC) Arrived on scene incid#=B23-05936 call=2731
DORMAN C	00:27:03 02/05/23	1747	ER	LB3	BPD	(MDC) Assigned as Responsible Unit for call 230204272
DORMAN C	00:27:42 02/05/23	1747	AR	LB3	BPD	(MDC) Arrived on scene incid#=B23-05936 call=2731
DORMAN C	00:27:54 02/05/23	1747	CE	LB3	BPD	(MDC) Completed call incid#=B23-05936 call=2731
BRITTON E	00:27:58 02/05/23	1707	CE	LB3	BPD	(MDC) Completed call incid#=B23-05936 call=2731

COMMENTS

23:45:44 02/04/2023 - YATES N  
LOUD PARTY  
23:46:42 02/04/2023 - YATES N  
SOUNDED LIKE THE CP WAS AT THE RESIDENCE  
00:27:04 02/05/2023 - DORMAN C  
Unit 1747 has replaced Unit 1707 as the responsible unit on call 2731  
00:27:53 02/05/2023 - DORMAN C  
cite

02/24/23  
10:52

BLOOMINGTON POLICE DEPARTMENT  
CALL DETAIL REPORT

Page: 365  
2

UNIT HISTORY

Unit	Time/Date	Code
1707	00:09:00 02/05/23	ER
1707	00:15:00 02/05/23	AR
1707	00:27:58 02/05/23	CE
1747	00:09:06 02/05/23	ENRT
1747	00:27:03 02/05/23	ER
1747	00:27:42 02/05/23	AR
1747	00:27:54 02/05/23	CE

RESPONDING OFFICERS

Unit	Officer
1707	BRITTON E
1747	DORMAN C

INVOLVEMENTS

Type	Record#	Date	Description	Relationship
LW	B23-05936	02/05/23	NOISE B23-05936 432 E SOUTHE	Initiating Call



# Appeal of Noise Citation to the Board of Public Works

City of Bloomington  
Department of Public Works  
401 North Morton Street, Suite 120  
Phone (812)349-3410  
Email: [Public.Works@Bloomington.IN.gov](mailto:Public.Works@Bloomington.IN.gov)

Please complete this form in its entirety. Use black or blue ink only and Print legibly. A copy of the Noise citation you were issued **MUST** be attached to this form. You are encouraged to attach all documents that you believe support your appeal. **All of these documents must be submitted within seven (7) days** after the Noise citation was issued. The Board of Public Works will primarily consider the written materials submitted, including: this appeal form, documents you provide, a statement from the police officer including any complaints made, and staff recommendations. In addition, on the date given below, you will have the opportunity to speak to the Board for two minutes. You will be notified of the Board's decision by first class mail. If your appeal is denied, you may file an appeal with the Monroe County Circuit Court.

Name: Marisol Sanchez Phone Number 210-452-7278

Citation Number: 40027 Date on Noise Citation: 02-05-23

(Located in the top right hand corner of the citation)

Local Address:  
423 E Southern Drive  
\_\_\_\_\_  
\_\_\_\_\_

Permanent Address:  
8910 Commemoro Court  
\_\_\_\_\_  
\_\_\_\_\_

Today's Date: 02-10-2023

Reason for Appeal: I Complied and worked with the officers directions. I did not cause any problems and answered all the gentlemen's questions. I do not think it is right that my house recieved a ticket, we never recieved a warning and this is the first time my house has recieved a noise complaint. Also, we had already turned our music off, which was not that loud, before the police came. Please consider my appeal and thank you for your time.

(You may continue on another page if necessary)

On this day, I submitted my completed appeal of Noise citation and received the date of 02-10-2023  
When the Board of Public Works will consider my appeal.

Marisol Sanchez  
Signature

02/10/23  
Date

**For use by Public Works:**

Date Appeal Received: \_\_\_\_\_ Received By: \_\_\_\_\_

Date Appeal Forwarded to Legal Department: \_\_\_\_\_



# **City of Bloomington's Board of Public Works** **Order on Appeal of Notice of Violation Ticket** **# 40027 (B23-05936)**

This matter is before the Board of Public Works for an Appeal of Notice of Violation # 40027 (B23-05936) (the "NOV") at 423 E. Southern Drive (the "Property"). The Board of Public Works received information regarding the NOV at its regular meeting on February 28, 2023.

The Board of Public Works now finds as follows:

1. Marisol Sanchez ("Appellant") appealed the NOV.
2. Appellant resides at the Property.
3. At approximately 11:45 p.m. on February 4, 2023 Bloomington Police Dispatch received a report of loud music and noise coming from the Property.
4. City of Bloomington Police Officer Chad Dorman responded to the call and, at approximately 12:27 a.m. on February 5, 2023, while not physically on the Property, heard music and sound coming from the Property.
5. These facts establish a prima facie violation of BMC 14.09.070(c)(4) in that the sound was clearly audible to a person with normal hearing from any place other than the premises from which the source of the sound is located, when the sound occurs between the hours of 9:00 p.m. and 7:00 a.m.
6. Appellant is a person under BMC 14.09.030(b) who can be held responsible for this violation.
7. The facts support a finding that the Appellant did violate BMC § 14.09 regarding unreasonable noise, and that this is Appellant's first violation of BMC § 14.09 within 12 months.

After reviewing all of the evidence and testimony presented, the Board of Public Works hereby Orders that the Appeal of NOV # 40027 (B23-05936) is denied.

**So Ordered this 28<sup>th</sup> Day of February, 2023.**

---

Kyla Cox Deckard, President  
Board of Public Works  
City of Bloomington

**STAFF REPORT**  
**NOV APPEAL (noise)**

---

**Appellant Information:**

Name: William Jontz  
Address: 437 E. 16<sup>th</sup> Street  
Bloomington, IN 47408  
Date Appealed: February 20, 2023

**NOV Information:**

Date Issued: February 18, 2023  
By: Officer Colin Deckard  
Where: 437 E. 16<sup>th</sup> Street  
For: Unreasonable Noise

---

**Attachments:**

1. Notice of Violation
2. Dispatch Records
3. Noise Appeal
4. Proposed Order

**Controlling Ordinances and Language:**

**BMC § 14.09.030(c)(4).** It shall be a violation of this chapter to play, use, operate or allow to be played, used, or operated any radio, television, digital media player, loudspeaker, sound amplifier, musical instrument, or any other machine or device for producing or reproducing sound in such a manner that the sound produced persists continuously or intermittently for a period of at least fifteen minutes and can be heard outside the immediate premises from the location of the emitter by a person with normal hearing. Sound that is clearly audible to a person with normal hearing from any place other than the premises from which the source of the sound is located, when the sound occurs between the hours of nine p.m. and seven a.m., is prima facie evidence of a violation of this section.

**BMC § 14.09.030(b).** Except as otherwise provided in this chapter, it shall be unlawful for any person to cause or make any unreasonable noise or to allow any unreasonable noise to be caused or made in or on any real or personal property occupied or controlled by that person.

**BMC § 14.09.070(b).** *Any person violating any of the provisions of this chapter, shall, upon a written finding of violation signed by the enforcement officer, be subject to an initial penalty of fifty dollars.* Each day such violation is committed or permitted to continue shall constitute a separate offense. A second violation in any twelve-month period is subject to a fine or penalty of one hundred dollars and subsequent violations within a twelve month period are subject to a fine or penalty of five hundred dollars. (emphasis added)

**Discussion:**

1. At approximately 4:16 p.m. on February 18, 2023, the Bloomington Police Department received a complaint regarding unreasonable noise at the property located at 437 E. 16<sup>th</sup> Street (the “Property”). Officer Deckard of the Bloomington Police Department responded to the noise complaint at approximately 4:35 p.m. on February 18, 2023.
2. Officer Deckard approached the Property in his patrol vehicle from several blocks away. While approaching the Property, but before entering the Property, Officer Deckard was able to clearly hear loud music from multiple blocks away, including from E. 16<sup>th</sup> Street and Lincoln Street and from E. 16<sup>th</sup> Street and Grant Street. Officer Deckard was able to identify that the sound was coming from the Property.
3. At approximately 4:49 p.m. on February 28, 2023, Officer Deckard made contact with William Jontz (“Appellant”) who is the/an occupant and tenant of the Property. Appellant was issued a ticket for unreasonable noise, and assessed a fine of \$50.
4. Appellant appealed the NOV.
5. The facts establish that the noise was unreasonable. The noise was audible from two blocks away.
6. Appellant occupies and has control of this property and is, therefore, a person who can and should be held responsible for this violation.
7. A fine of \$50 is appropriate because this is the first noise violation issued to Appellant and at this Property in a 12-month period

**Staff Recommendation:**

1. The appeal should be denied.

COUNTY OF MONROE  
CITY OF BLOOMINGTON  
ORDINANCE VIOLATION

NO. 37913

The undersigned having probable cause to believe and being duly sworn upon his/her oath says that on:

Day of Week SAT	Day 18	Month Feb	Year 2023	Time 16:41
Last Name Jantz			First William	MI R
Street Address 437 E 16th St				D.O.B. 5/13/00
City Bloomington		State IN	Zip Code 47108	
Sex W	Race M	S [REDACTED]		

DID COMMIT THE FOLLOWING OFFENSE:

NOISE

OR

Excessive Loud Noise

Residence

Vehicle

Contrary to the BMC § 16.51.038

at

437 E 16th St

Bloomington, IN.

Officer's Signature

[Signature]

I.D. No.

7713

City of Bloomington, Indiana

Date

2/13/23

Signature

[Signature]

Your signature is not an admission of guilt.

SEE OTHER SIDE FOR ADDITIONAL INFORMATION

02/24/23  
10:53

BLOOMINGTON POLICE DEPARTMENT  
CALL DETAIL REPORT

Page: 365  
1

Call Number: 230218174

Nature: NOISE  
Reported: 16:16:18 02/18/23  
Rcvd By: BORDERS J How Rcvd: T  
Occ Btwn: 16:16:18 02/18/23 and 16:17:26 02/18/23  
Type: 1  
Priority: 4

Address: 437 E 16TH ST  
City: BLOOMINGTON

Alarm:

COMPLAINANT/CONTACT  
-----

Complainant: , Name#:   
Race: Sex: DOB: \*\*/\*\*/\*\*   
Address: ,   
Home Phone: Work Phone:

Contact: ANONYMOUS  
Address:  
Phone:

RADIO LOG  
-----

Dispatcher	Time/Date	Unit	Code	Zone	Agnc	Description
DECKARD C	16:35:46 02/18/23	1725	ER	LB2	BPD	(MDC) Enroute to a call incid#=B23-08307 call=1731
SNIDER T	16:35:52 02/18/23	1748	ENRT	LB2	BPD	(MDC) Assisting unit 1725 incid#=B23-08307 call=1731
DECKARD C	16:37:34 02/18/23	1725	AR	LB2	BPD	(MDC) Arrived on scene incid#=B23-08307 call=1731
SNIDER T	16:38:43 02/18/23	1748	AR	LB2	BPD	(MDC) Arrived on scene incid#=B23-08307 call=1731
DECKARD C	16:49:41 02/18/23	1725	CE	LB2	BPD	(MDC) Completed call incid#=B23-08307 call=1731
SNIDER T	16:54:53 02/18/23	1748	CE	LB2	BPD	(MDC) Completed call incid#=B23-08307 call=1731

COMMENTS  
-----

16:16:30 02/18/2023 - BORDERS J  
\*EDITED\* LOUD SPEAKERS  
16:17:24 02/18/2023 - KELLEY P  
2ND CALLER  
16:40:34 02/18/2023 - ROCK K  
Address change from 409 E 16TH ST to 437 E 16TH ST  
16:49:38 02/18/2023 - DECKARD C  
ONE NOISE CIT GIVEN TO RESIDENT WILLIAM JONTZ WHO REFUSED TO SIGN COPY. WILLIAM  
PROVIDED WITH COPY. COULD HEAR NOISE FROM E 16TH ST AND N GRANT ST.

02/24/23  
10:53

BLOOMINGTON POLICE DEPARTMENT  
CALL DETAIL REPORT

Page: 365  
2

UNIT HISTORY

Unit	Time/Date	Code
1725	16:35:46 02/18/23	ER
1725	16:37:34 02/18/23	AR
1725	16:49:41 02/18/23	CE
1748	16:35:52 02/18/23	ENRT
1748	16:38:43 02/18/23	AR
1748	16:54:53 02/18/23	CE

RESPONDING OFFICERS

Unit	Officer
1725	DECKARD C
1748	SNIDER T

INVOLVEMENTS

Type	Record#	Date	Description	Relationship
LW	B23-08307	02/18/23	NOISE B23-08307 437 E 16TH S	Initiating Call





# Appeal of Noise Citation to the Board of Public Works

City of Bloomington  
Department of Public Works  
401 North Morton Street, Suite 120  
Phone (812)349-3410  
Email: [Public.Works@Bloomington.IN.gov](mailto:Public.Works@Bloomington.IN.gov)

Please complete this form in its entirety. Use black or blue ink only and Print legibly. A copy of the Noise citation you were issued **MUST** be attached to this form. You are encouraged to attach all documents that you believe support your appeal. **All of these documents must be submitted within seven (7) days** after the Noise citation was issued. The Board of Public Works will primarily consider the written materials submitted, including: this appeal form, documents you provide, a statement from the police officer including any complaints made, and staff recommendations. In addition, on the date given below, you will have the opportunity to speak to the Board for two minutes. You will be notified of the Board's decision by first class mail. If your appeal is denied, you may file an appeal with the Monroe County Circuit Court.

Name: William Jontz Phone Number (810)-964-9455

Citation Number: 37913 Date on Noise Citation: 02/18/2023  
(Located in the top right hand corner of the citation)

Local Address:  
437 E 16<sup>th</sup> Bloomington Indiana 47408  
\_\_\_\_\_  
\_\_\_\_\_

Permanent Address:  
1012 Pinewood Court, Brighton MI 48116  
\_\_\_\_\_  
\_\_\_\_\_

Today's Date: 02/20/2023

Reason for Appeal: \_\_\_\_\_

- It was not that loud. We were all able to have conversations with ease in front of the speaker. We were also never asked to turn it down which we would've been happy to have done if had been asked to do so.
- It was country music so there was no profanity or explicit language or heavy bass/beat that would be seen as disruptive or hurtful.
- The officer issuing the ticket made two errors on the ticket he gave me. He listed me as a W for Sex and M for Race. I am neither a Women nor of Mexican decent. I am a White Male as listed on my driver's license.
- The officer claims he heard the music on Grant Street, but I have one friend, Trey Walker, who lives just on the other side of Grant street and he said he couldn't hear the music from his house. I also had two friends, Tianna Hart and Liam Zaccheo, who walked over from Grant Street and they both say they couldn't hear the music until they got much closer to the party.
- There was also another outdoor party that was going on at the house across the street from us with the same level of speaker noise and were not approached at all.

(You may continue on another page if necessary)

On this day, I submitted my completed appeal of Noise citation and received the date of \_\_\_\_\_

When the Board of Public Works will consider my appeal.

02/20/2023

Signature

Date

**For use by Public Works:**

Date Appeal Received: \_\_\_\_\_ Received By: \_\_\_\_\_

Date Appeal Forwarded to Legal Department: \_\_\_\_\_

# **City of Bloomington's Board of Public Works** **Order on Appeal of Notice of Violation Ticket** **# 37913 (B23-08307)**

This matter is before the Board of Public Works for an Appeal of Notice of Violation # 37913 (B23-08307) (the "NOV") at 437 E 16<sup>th</sup> Street (the "Property"). The Board of Public Works received information regarding the NOV at its regular meeting on February 28, 2023.

The Board of Public Works now finds as follows:

1. William Jontz ("Appellant") appealed the NOV.
2. Appellant resides at the Property.
3. At approximately 4:16 p.m. on February 18, 2023 Bloomington Police Dispatch received a report of loud music and noise coming from the Property.
4. City of Bloomington Police Officer Colin Deckard responded to the call and, at approximately 4:37 p.m. on February 18, 2023, while not physically on the Property, heard music and sound coming from the Property. Officer Deckard heard loud music coming from the property from multiple blocks away.
5. These facts establish a violation of BMC 14.09.030(b) in that the sound was clearly audible to a person with normal hearing from multiple blocks away, and constitutes unreasonable noise, as the noise was of a volume, frequency, or pattern that prevents, disrupts, injures, or endangers the health, safety, welfare, prosperity, comfort or repose of reasonable persons of ordinary sensitivities.
6. Appellant is a person under BMC 14.09.030(b) who can be held responsible for this violation.
7. The facts support a finding that the Appellant violated BMC § 14.09 regarding unreasonable noise, and that this is Appellant's first violation of BMC § 14.09 within 12 months.

After reviewing all of the evidence and testimony presented, the Board of Public Works hereby Orders that the Appeal of NOV #37913 (B23-08307) is denied.

**So Ordered this 28<sup>th</sup> Day of February, 2023.**

---

Kyla Cox Deckard, President  
Board of Public Works  
City of Bloomington

The Board of Public Works meeting was held Tuesday, February 14, 2023 at 5:30 pm in the Council Chambers of City Hall at 401 N. Morton St., Bloomington, Indiana and virtually through Zoom with Kyla Cox Deckard presiding.

**REGULAR MEETING OF THE BOARD OF PUBLIC WORKS**

Present: Kyla Cox Deckard  
Elizabeth Karon  
Jennifer Lloyd

**ROLL CALL**

City Staff: Adam Wason – Public Works  
April Rosenberger – Public Works  
Aleksandrina Pratt – City Legal, Via Zoom  
Neil Kopper -- Engineering  
Paul Kehrberg – Engineering  
Jason Kerr - Engineering  
Alex Gray -- Engineering

**MESSAGES FROM BOARD MEMBERS**

None

None

**PETITIONS & REMONSTRANCES**

1. Approval of Minutes; January 31, 2023
2. 2023 Service Agreement with Precision Concrete, Inc. to Remove Sidewalk Trip Hazards
3. Resolution 2023-06; International Festival
4. Resolution 2023-07; Declaration of Surplus by Bloomington Police Department
5. Approval of Payroll

**CONSENT AGENDA**

**Board Comments:** None

Karon made a motion to approve the Consent Agenda. Lloyd seconded. All in favor, motion is passed.

Neil Kopper, Engineering, presented Contract with J.R. Ellington Tree Experts for the West 1<sup>st</sup> Street Tree Removal Project. See meeting packet for details.

**NEW BUSINESS**  
**Contract with J.R. Ellington Tree Experts for the West 1<sup>st</sup> Street Tree Removal Project**

**Board Comments:** None

Karon made a motion to approve Contract with J.R. Ellington Tree Experts for the West 1<sup>st</sup> Street Tree Removal Project. Lloyd seconded. All in favor, motion is passed.

Paul Kehrberg, Engineering, Request from Goodman Construction for Lane Closure at 1800 N. Walnut St. (February 20, 2023-March 31, 2023). See meeting packet for details.

**Request from Goodman Construction for Lane Closure at 1800 N. Walnut St. (February 20, 2023-March 31, 2023)**

**Board Comments:** None

Karon made a motion to approve Request from Goodman Construction for Lane Closure at 1800 N. Walnut St. (February 20, 2023-March 31, 2023). Lloyd seconded. All in favor, motion is passed.

Paul Kehrberg, Engineering, presented Request from Gilliatte General Contracting for Lane and Sidewalk Closures on S. Grant. See meeting packet for details.

**Request from Gilliatte General Contracting for Lane and Sidewalk Closures on S. Grant**

**Board Comments:** Cox Deckard asked to confirm that the 4<sup>th</sup> Street sidewalk would not be closed. Kehrberg confirmed that it would not.

Karon made a motion to approve Request from Gilliatte General Contracting for Lane and Sidewalk Closures on S. Grant. Lloyd seconded. All in favor, motion is passed.

Jason Kerr, Engineering, presented Request from AEG for Lane and Sidewalk Closures. See meeting packet for details.

**Request from AEG for Lane and Sidewalk Closures**

**Board Comments:** Karon asked if AEG is responsive to complaints. Kerr confirmed.

Karon made a motion to approve Request from AEG for Lane and Sidewalk Closures. Lloyd seconded. All in favor, motion is passed.

Jason Kerr, Engineering, presented Request from Centerpoint Energy for Street and Sidewalk Closures along S. Rockport Road. See meeting packet for details.

**Request from Centerpoint Energy for Street and Sidewalk Closures along S. Rockport Road**

**Board Comments:** Cox Deckard asked what time the work would end each day. Kerr answered their work day will be from 7:30 – 5:00. Lloyd questioned the application stating 7:00 – 5:30. Kerr confirmed that 7:00 – 5:30 is the correct time. Cox Deckard asked about communication with Bloomington Transit. Kerr stated he had given Centerpoint the information to reach out to Bloomington Transit.

Karon made a motion to approve the Request from Centerpoint Energy for Street and Sidewalk Closures along S. Rockport Road. Lloyd seconded. All in favor, motion is passed.

Jason Kerr, Engineering, presented Request from Red Truck Bloomington LLC to place Dumpster in Right-of-Way at 402 and 406 W. 6<sup>th</sup> St. (March 6, 2023- up to 90 days). See meeting packet for details.

**Request from Red Truck Bloomington LLC to place Dumpster in Right-of-Way at 402 and 406 W. 6<sup>th</sup> St. (March 6, 2023- up to 90 days)**

**Board Comments:** Karon asked if the approval is for the start date of March 6<sup>th</sup>, would there be an issue with the work beginning sooner. Wason answered that there wouldn't be an issue.

Karon made a motion to approve the Request from Red Truck Bloomington LLC to place Dumpster in Right-of-Way at 402 and 406 W. 6<sup>th</sup> St. (March 6, 2023- up to 90 days). Lloyd seconded. All in favor, motion is passed.

Adam Wason, Public Works, presented Concrete Materials Contract with Irving Materials, Inc. on behalf of Joe VanDeventer, Street Division. See meeting packet for details.

**Concrete Materials Contract with Irving Materials, Inc.**

**Board Comments:** Cox Deckard asked to clarify the amount on the Staff Report. Wason stated the amount was a typo and the amount is supposed to read \$144.00 per yard.

Karon made a motion to approve the Concrete Materials Contract with Irving Materials, Inc. Lloyd seconded. All in favor, motion is passed.

Adam Wason, Public Works, presented Asphalt Material Contract with E&B Paving, Inc. (Primary) and Milestone Contractors, LP (Secondary) for Joe VanDeventer, Street Division. See meeting packet for details.

Board Comments: None

Karon made a motion to approve the Asphalt Material Contract with E&B Paving, Inc. (Primary) and Milestone Contractors, LP (Secondary). Lloyd seconded.

Adam Wason, Public Works, stated there wasn't anything major to announce. Stated that the Animal Shelter would be running an adoption special on dogs the following weekend and trying to clear some space.

Karon made a motion to approve claims in the amount of \$3,187,446.57. Lloyd seconded. All in favor, motion is passed.

Cox Deckard called for adjournment at 5:52 p.m.

Accepted By:

\_\_\_\_\_  
Kyla Cox Deckard, President

\_\_\_\_\_  
Elizabeth Karon, Vice President

\_\_\_\_\_  
Jennifer Lloyd, Secretary

Date:

Attest to:

**Asphalt Material Contract with E&B Paving, Inc. (Primary) and Milestone Contractors, LP (Secondary)**

**STAFF REPORTS AND OTHER BUSINESS**

**CLAIMS**

**ADJOURNMENT**





## Board of Public Works Staff Report

---

**Project/Event:** Approve Bonding Agreement with Indiana University

**Staff Representative:** Paul Kehrberg, Engineering

**Petitioner/Representative:** Trustees of Indiana University; Donald Lukes

**Date:** February 28, 2023

---

**Report:** City Code allows for various entities to apply for a bonding agreement with the City of Bloomington. This agreement makes the applicant exempt from the bonding requirements otherwise required by code. This covers their routine work within City rights of way. Indiana University is seeking approval of their bonding agreement with the City of Bloomington..

# 2023 BONDING AGREEMENT

## ENGINEERING DEPARTMENT, CITY OF BLOOMINGTON, INDIANA

**THIS AGREEMENT** entered into this \_\_\_\_\_ day of \_\_\_\_\_, 2023, by and between the City of Bloomington, a Municipal Corporation of Indiana (hereinafter referred to as CITY), and The Trustees of Indiana University (hereinafter referred to as APPLICANT).

### RECITALS:

- A. APPLICANT has filed, or soon will file, an application with the CITY for a permit to perform excavation and restoration work on CITY's public ways.
- B. APPLICANT guarantees faithful performance of the work in full compliance with Bloomington Municipal Code Chapter 12.08 Use of the Right of Way and other applicable CITY ordinances, regulations, specifications and standards listed on the CITY Engineering Department's resources website (the "City Standards").
- C. APPLICANT acknowledges that this 2023 Bonding Agreement shall terminate on December 31, 2023.

### AGREEMENT:

**NOW, THEREFORE**, in consideration of the recitals above, the mutual covenants and undertakings of the parties hereto, and for other good and valuable consideration, the receipt and legal sufficiency of which is hereby acknowledged, the parties hereto agree as follows:

1. **Applicant's Completion and Warranty Obligations.** APPLICANT irrevocably acknowledges its obligation to perform the work in a good, workmanlike, lien-free manner in full compliance with City Standards. APPLICANT further warrants that the work will be free of defects (normal wear and tear excepted) for a period of two (2) years after the work has been completed and finally accepted by CITY, assuming the CITY inspects the work within a reasonable timeframe after being properly notified of its completion.
2. **Applicant's Covenants.** APPLICANT irrevocably represents, warrants and covenants to CITY as follows:
  - (a) **Compliance with City Standards.** That APPLICANT shall fully comply with all City Standards relative to the work, and fully and promptly indemnify and hold harmless CITY, and respond to CITY, for APPLICANT's failure to conform with such obligations.
  - (b) **Completion of the Work.**
    - i. **Diligence.** That after the work is commenced, APPLICANT shall proceed with diligence and expedition and shall promptly complete the work and restore the property to City Standards, so as not to

obstruct the property or public use or travel thereon more than is reasonably necessary.

- ii. **Restoration.** That unless authorized by CITY on the permit, all paving, resurfacing or replacement of street facilities on major or collector streets shall be done in conformance with City Standards as soon as reasonably possible. In winter, a temporary patch must be provided. In all excavations, restoration and pavement surfaces shall be made immediately after backfilling is completed or concrete is cured.

(c) That APPLICANT shall guarantee the materials and workmanship of the work in compliance with City Standards for a period of two (2) years from completion and CITY's acceptance of the work, with reasonable wear and tear excepted.

3. **Repairs.** All responsibility for completion, repair and maintenance of the work shall remain with APPLICANT until all of the work has been completed in full compliance with City Standards, inspected and finally accepted by CITY, and the warranty has expired.
4. **Contractors.** This Agreement does not extend to contractors applying for permit on behalf of APPLICANT.
5. **Binding Agreement.** This Agreement shall be binding upon and shall inure to the benefit of the successors and assigns of the respective parties hereto.
6. **Counterparts.** This Agreement may be signed in any number of counterparts with the same effect as if the signatures upon any counterpart were upon the same instrument. All signed counterparts shall be deemed to be one original.
7. **Severability.** The provisions of this Agreement are severable, and should any provision hereof be void, voidable, unenforceable or invalid, such void, voidable, unenforceable or invalid provision shall not affect the other provisions of this Agreement.
8. **Amendment.** This Agreement may not be modified except by an instrument in writing signed by the parties hereto.
9. **Interpretation.** This Agreement shall be interpreted, construed and enforced according to the substantive laws of the State of Indiana.
10. **Assignment.** APPLICANT may not assign or otherwise convey its rights or delegate its duties under this Agreement without the express written consent of CITY.
11. **No Partnership.** CITY and APPLICANT do not by this Agreement in any way or for any purpose become partners or joint ventures with each other.

APPLICANT

Entity: The Trustees of Indiana University

By Donald S. Lukes, University Treasurer

(JMG) Signature *Small D Lukes*  
Electronically signed by:  
Donald Lukes  
Date: Feb 10, 2023 16:19 EST

Date Signed Feb 10, 2023

## BOND WAIVER

The Board of Public Works, having reviewed the Bonding Agreement herein, approves and accepts said Bonding Agreement for the remainder of calendar year 2023. The Board of Public Works hereby finds the APPLICANT to be exempt from the provisions of Bloomington Municipal Code Section 12.08.060.

### CITY OF BLOOMINGTON BOARD OF PUBLIC WORKS

\_\_\_\_\_  
Kyla Cox Deckard, President

Date: \_\_\_\_\_

\_\_\_\_\_  
Elizabeth Karon, Vice President

Date: \_\_\_\_\_

\_\_\_\_\_  
Jennifer Lloyd, Secretary

Date: \_\_\_\_\_

\_\_\_\_\_  
Andrew Cibor, Director  
Engineering Department

Date: \_\_\_\_\_

\_\_\_\_\_  
Beth Cate  
Corporation Counsel

Date: \_\_\_\_\_



## Board of Public Works Staff Report

---

**Project/Event:** Approve Bonding Agreement with City of Bloomington Utilities Transmission and Distribution

**Staff Representative:** Paul Kehrberg

**Petitioner/Representative:** James Hall, CBU

**Date:** February 28, 2023

---

**Report:** City Code allows for various entities to apply for a bonding agreement with the City of Bloomington. This agreement makes the applicant exempt from the bonding requirements otherwise required by code. City of Bloomington Utilities is seeking to have their bonding agreement renewed for 2023 for their routine work in the City rights of way. This agreement does not apply to large scale construction contracts completed by other contractors.

# 2023 BONDING AGREEMENT

## ENGINEERING DEPARTMENT, CITY OF BLOOMINGTON, INDIANA

THIS AGREEMENT entered into this 8<sup>th</sup> day of February, 2023, by and between the City of Bloomington, a Municipal Corporation of Indiana (hereinafter referred to as CITY), and the City of Bloomington Utilities Department (hereinafter referred to as APPLICANT).

### RECITALS:

- A. APPLICANT has filed, or soon will file, an application with the CITY for a permit to perform excavation and restoration work on CITY's public ways.
- B. APPLICANT guarantees faithful performance of the work in full compliance with Bloomington Municipal Code Chapter 12.08 Use of the Right of Way and other applicable CITY ordinances, regulations, specifications and standards listed on the CITY Engineering Department's resources website (the "City Standards").
- C. APPLICANT acknowledges that this 2023 Bonding Agreement shall terminate on December 31, 2023.

### AGREEMENT:

**NOW, THEREFORE**, in consideration of the recitals above, the mutual covenants and undertakings of the parties hereto, and for other good and valuable consideration, the receipt and legal sufficiency of which is hereby acknowledged, the parties hereto agree as follows:

1. **Applicant's Completion and Warranty Obligations.** APPLICANT irrevocably acknowledges its obligation to perform the work in a good, workmanlike, lien-free manner in full compliance with City Standards. APPLICANT further warrants that the work will be free of defects (normal wear and tear excepted) for a period of two (2) years after the work has been completed and finally accepted by CITY, assuming the CITY inspects the work within a reasonable timeframe after being properly notified of its completion.
2. **Applicant's Covenants.** APPLICANT irrevocably represents, warrants and covenants to CITY as follows:
  - (a) **Compliance with City Standards.** That APPLICANT shall fully comply with all City Standards relative to the work, and fully and promptly indemnify and hold harmless CITY, and respond to CITY, for APPLICANT's failure to conform with such obligations.
  - (b) **Completion of the Work.**
    - i. **Diligence.** That after the work is commenced, APPLICANT shall proceed with diligence and expedition and shall promptly complete the work and restore the property to City Standards, so as not to



obstruct the property or public use or travel thereon more than is reasonably necessary.

- ii. **Restoration.** That unless authorized by CITY on the permit, all paving, resurfacing or replacement of street facilities on major or collector streets shall be done in conformance with City Standards as soon as reasonably possible. In winter, a temporary patch must be provided. In all excavations, restoration and pavement surfaces shall be made immediately after backfilling is completed or concrete is cured.

(c) That APPLICANT shall guarantee the materials and workmanship of the work in compliance with City Standards for a period of two (2) years from completion and CITY's acceptance of the work, with reasonable wear and tear excepted.

3. **Repairs.** All responsibility for completion, repair and maintenance of the work shall remain with APPLICANT until all of the work has been completed in full compliance with City Standards, inspected and finally accepted by CITY, and the warranty has expired.
4. **Contractors.** This Agreement does not extend to contractors applying for permit on behalf of APPLICANT.
5. **Binding Agreement.** This Agreement shall be binding upon and shall inure to the benefit of the successors and assigns of the respective parties hereto.
6. **Counterparts.** This Agreement may be signed in any number of counterparts with the same effect as if the signatures upon any counterpart were upon the same instrument. All signed counterparts shall be deemed to be one original.
7. **Severability.** The provisions of this Agreement are severable, and should any provision hereof be void, voidable, unenforceable or invalid, such void, voidable, unenforceable or invalid provision shall not affect the other provisions of this Agreement.
8. **Amendment.** This Agreement may not be modified except by an instrument in writing signed by the parties hereto.
9. **Interpretation.** This Agreement shall be interpreted, construed and enforced according to the substantive laws of the State of Indiana.
10. **Assignment.** APPLICANT may not assign or otherwise convey its rights or delegate its duties under this Agreement without the express written consent of CITY.
11. **No Partnership.** CITY and APPLICANT do not by this Agreement in any way or for any purpose become partners or joint ventures with each other.

APPLICANT

Entity: City of Bloomington Utilities Department

By Vic Kelson, Director

Signature     *VAK*    

Date Signed     2/8/2023    

### BOND WAIVER

The Board of Public Works, having reviewed the Bonding Agreement herein, approves and accepts said Bonding Agreement for the remainder of calendar year 2023. The Board of Public Works hereby finds the APPLICANT to be exempt from the provisions of Bloomington Municipal Code Section 12.08.060.

#### CITY OF BLOOMINGTON BOARD OF PUBLIC WORKS

\_\_\_\_\_  
Kyla Cox Deckard, President

Date: \_\_\_\_\_

\_\_\_\_\_  
Elizabeth Karon, Vice President

Date: \_\_\_\_\_

\_\_\_\_\_  
Jennifer Lloyd, Secretary

Date: \_\_\_\_\_

\_\_\_\_\_  
Andrew Cibor, Director  
Engineering Department

Date: \_\_\_\_\_

\_\_\_\_\_  
Beth Cate  
Corporation Counsel

Date: \_\_\_\_\_



# Board of Public Works Staff Report

---

**Project/Event:** Declaration of Surplus Fleet Vehicles  
**Petitioner/Representative:** Michael Large, Operations Manager, DPW  
**Staff Representative:** Michael Large  
**Date:** February 28, 2023

---

## Report:

The Fleet Maintenance Division purchases and provides vehicles and equipment to various City departments so that they can provide a wide range of vital municipal government services to the residents of Bloomington. These vehicles and equipment all have limited service lives determined by their type and operational duties. As these assets reach the end of their lifecycle they are reclaimed by the Fleet Maintenance Division and replaced. The Fleet Maintenance Division has three vehicles, two pieces of equipment and one riding lawn mower that have been placed out of service and wishes to dispose of them as surplus property via the utilization of govdeals.com, an online auctioning service. To date this collaboration with Govdeals.com has resulted in more than \$171,000 in revenue received. All revenue received from the online auction is placed directly in the City of Bloomington's Vehicle Replacement Fund for future capital vehicle purchasing needs.

Staff is requesting that the Board of Public Works declare the vehicles and equipment in Attachment A as surplus so that they can be sold on govdeals.com.

Staff also notes that in the present case, the equipment was inadvertently sold prior to the Board's authorization. Under the authority granted to this Board by Indiana Code § 36-1-4-16, staff is requesting that the Board ratify the surplus declaration and sale via Resolution 2023-05.

---

## Recommendation and Supporting Justification:

Recommend  Approval  Denial by: *Michael Large*

**RESOLUTION 2023-05  
TO DESIGNATE SURPLUS PROPERTY FOR TRANSFER**

**WHEREAS**, the City of Bloomington, Department of Public Works, Fleet Maintenance Division, was in possession of vehicles and equipment that have reached the end of their lifecycles; and

**WHEREAS**, the Fleet Maintenance Division sold the surplus property using an Internet auction site; and

**WHEREAS**, Indiana Code § 5-22-22-4.5 and Board of Public Works Resolution 2020-10, permits the City of Bloomington Board of Public Works to declare the property surplus for purposes of disposal and to sell the surplus property at an Internet auction site.

**NOW, THEREFORE**, be it hereby resolved by the City of Bloomington Board of Public Works that:

1. The City of Bloomington property described in Exhibit A is hereby declared surplus.
2. The sale of the City of Bloomington property described in Exhibit A is hereby authorized.
3. Pursuant to Indiana Code § 36-1-4-16, to the extent that municipal officers or employees have taken action related to the property described in Exhibit A in advance of the Board's authorization for said action, the Board hereby ratifies said prior actions.

**SO PASSED AND ADOPTED** this \_\_\_\_ day of \_\_\_\_\_, 2023, by the City of Bloomington Board of Public Works

\_\_\_\_\_  
Kyla Cox-Deckard, President

\_\_\_\_\_  
Elizabeth Karon, Vice President

\_\_\_\_\_  
Jennifer Lloyd, Secretary

## Attachment A

## Declaration of Surplus BPW 2.14.23

Asset #	Department	Model Year	Make/Model	VIN/Serial Number	Sale Price
505	CBU	2001	GMC Safari Van AWD	1GKEL19W01B500051	\$3,325.95
609	CBU	2014	Scag STT61V-25KBD mower	K1600019	\$3,990.00
770	CBU	2004	Chevy Blazer	1GNNDT13Z64K155595	\$2,225.00
804	Parks	2007	COLORADO	1GCCS139878232638	\$4,300.00
	DPW - Fleet	1999	Champion Air Compressor-Gas		\$200.56
	DPW - Fleet		Ammco Brake Lathe		\$484.50



# City of Bloomington

## Disposal / Surplus / Trade In Form

PAGE NO. 1 of 1

DEPT: Public Works Fleet Division

DATE: 2/21/2023

LOCATION: 800 E. Miller Dr.

PHONE: \_\_\_\_\_

DEPT. HEAD / DIVISION DIRECTOR: Adam Wason

EMAIL: largem@bloomington.in.gov

DESCRIPTION (List Make, Model, and Year)	QTY	DECLARATION REASON (works, needs repair, not repairable, etc)	SERIAL / VIN NO.	COB ASSET #	DISPOSITION REQUESTED (Please check one)	NAME OF VENDOR/PERSON OR COMPANY THE ITEM WAS SURPLUSED OR TRADED TO	ESTIMATED VALUE	SURPLUS DATE
1. 2001 GMC Safari Van AWD	1	End of Service Life	1GKEL19W01B500051	505	<input checked="" type="checkbox"/> Sell <input type="checkbox"/> Trade <input type="checkbox"/> Transfer <input type="checkbox"/> Dispose	GovDeals.com	\$2,000.00	02/14/23
2. 2004 Chevy Blazer	1	End of Service Life	1GNDD13Z64K155595	770	<input checked="" type="checkbox"/> Sell <input type="checkbox"/> Trade <input type="checkbox"/> Transfer <input type="checkbox"/> Dispose	GovDeals.com	\$1,500.00	02/14/23
3. 2007 Chevy Colorado	1	End of Service Life	1GCCS139878232638	804	<input checked="" type="checkbox"/> Sell <input type="checkbox"/> Trade <input type="checkbox"/> Transfer <input type="checkbox"/> Dispose	GovDeals.com	\$3,000.00	02/14/23
4. 2014 Scag STT61V-25KBD Mower	1	End of Service Life	K1600019	609	<input checked="" type="checkbox"/> Sell <input type="checkbox"/> Trade <input type="checkbox"/> Transfer <input type="checkbox"/> Dispose	GovDeals.com	\$2,500.00	02/14/23
5. 1999 Champion Air Compressor-Gas	1	End of Service Life			<input checked="" type="checkbox"/> Sell <input type="checkbox"/> Trade <input type="checkbox"/> Transfer <input type="checkbox"/> Dispose	GovDeals.com	\$100.00	02/14/23
6. Ammco Brake Lathe	1	End of Service Life			<input checked="" type="checkbox"/> Sell <input type="checkbox"/> Trade <input type="checkbox"/> Transfer <input type="checkbox"/> Dispose	GovDeals.com	\$200.00	02/14/23
7.					<input type="checkbox"/> Sell <input type="checkbox"/> Trade <input type="checkbox"/> Transfer <input type="checkbox"/> Dispose			
8.					<input type="checkbox"/> Sell <input type="checkbox"/> Trade <input type="checkbox"/> Transfer <input type="checkbox"/> Dispose			
9.					<input type="checkbox"/> Sell <input type="checkbox"/> Trade <input type="checkbox"/> Transfer <input type="checkbox"/> Dispose			
10.					<input type="checkbox"/> Sell <input type="checkbox"/> Trade <input type="checkbox"/> Transfer <input type="checkbox"/> Dispose			
11.					<input type="checkbox"/> Sell <input type="checkbox"/> Trade <input type="checkbox"/> Transfer <input type="checkbox"/> Dispose			
12.					<input type="checkbox"/> Sell <input type="checkbox"/> Trade <input type="checkbox"/> Transfer <input type="checkbox"/> Dispose			
13.					<input type="checkbox"/> Sell <input type="checkbox"/> Trade <input type="checkbox"/> Transfer <input type="checkbox"/> Dispose			
14.					<input type="checkbox"/> Sell <input type="checkbox"/> Trade <input type="checkbox"/> Transfer <input type="checkbox"/> Dispose			
15.					<input type="checkbox"/> Sell <input type="checkbox"/> Trade <input type="checkbox"/> Transfer <input type="checkbox"/> Dispose			
16.					<input type="checkbox"/> Sell <input type="checkbox"/> Trade <input type="checkbox"/> Transfer <input type="checkbox"/> Dispose			



## Board of Public Works Staff Report

---

**Project/Event:** Disposal of Surplus Items by the City of Bloomington – Information & Technology Services

**Staff Representative:** Rick Dietz

**Date:** February 15, 2023

---

### Report:

The Department of Information & Technology Services has a large stock of computer equipment and peripherals that are inoperable or recyclable.

The Department of Information & Technology Services staff believe that the expense of labor, equipment, and fuel required to organize and transport all of this equipment for a sale or transfer, exceeds the value of the equipment. These identified beginning July 2022 items are provided for the Exhibit to Resolution 2023-08: Recycle Lot 51 BPD.

---

### Recommendation and Supporting Justification:

Under Indiana Code § 5-22-22-6, the City of Bloomington Board of Public Works may determine these devices to be surplus property and may conduct a public or private sale or transfer the property without advertising, as there is more than one (1) item, and the value of these inoperable and/or outdated devices is less than five thousand dollars (\$5,000).

Alternatively, under Indiana Code § 5-22-22-7, the City of Bloomington Board of Public Works may determine these devices to be surplus property and may conduct a public or private sale or transfer the property without advertising if the devices may be recycled in conjunction with a recycling program. Additionally, under Indiana Code § 5-22-22-8, the City of Bloomington Board of Public Works may determine these devices to be worthless property which may be demolished or junked; the property is considered worthless if the value is less than the estimated cost of sale or transportation.

**Recommend:**  Approval  Denial by: Rick Dietz

**BOARD OF PUBLIC WORKS  
RESOLUTION 2023-08**

**TO DISPOSE OF SURPLUS PERSONAL PROPERTY  
OWNED BY THE CITY OF BLOOMINGTON**

WHEREAS, the City of Bloomington Information & Technology Services Department (“ITS”) purchases and provides equipment for City Departments including, but not limited to, computers, computer hard drives, keyboards, monitors, and other computer accessories, which are used by a significant portion of City employees in order to assist the employees in their work on behalf of the City; and

WHEREAS, all of this equipment has limited life cycles; and

WHEREAS, as this equipment becomes inoperable and/or outdated it is returned to ITS by City Departments, and ITS provides those Departments with new replacement equipment; and

WHEREAS, ITS has a large stock of returned equipment which ITS wishes to dispose of as surplus personal property; and

WHEREAS, this equipment is identified in Exhibit A, which is attached hereto and incorporated herein by reference; and

WHEREAS, pursuant to Indiana Code § 5-22-22-6, the City of Bloomington Board of Public Works (hereinafter “Board of Public Works”) may determine this equipment to be surplus property and may conduct a private sale or transfer the property without advertising, as there is more than one (1) item, and the value of this inoperable and/or outdated equipment is less than five thousand dollars (\$5,000); and

WHEREAS, ITS has assessed the value of this equipment contained in Exhibit A to be less than five thousand dollars (\$5,000); and

WHEREAS, pursuant to Indiana Code § 5-22-22-8, the Board of Public Works is also authorized to consider this equipment worthless, if the value of the equipment is less than the estimated cost of the sale and transportation of the equipment; and

WHEREAS, in considering the expense of labor, equipment and fuel required to organize and transport all of this equipment contained in Exhibit A for a sale or transfer, ITS believes that these costs exceed the value of the equipment; and

NOW, THEREFORE, be it hereby resolved by the Board of Public Works that:

1. The equipment contained in Exhibit A is hereby declared to be surplus personal property.
2. The value of the equipment contained in the Exhibit is assessed to be less than five thousand dollars (\$5,000).
3. The costs of transporting this equipment and conducting a private sale exceed the value of the equipment.



4. The equipment contained in Exhibit A is therefore determined to be worthless and, pursuant to Indiana Code § 5-22-22-8, may be demolished, offered for recycling, donated or junked.

**PASSED AND ADOPTED by the City of Bloomington Board of Public Works this \_\_\_\_\_ day of February, 2023.**

**BOARD OF PUBLIC WORKS**

\_\_\_\_\_  
Kyla Cox Deckard, President

\_\_\_\_\_  
Elizabeth Karon, Vice President

\_\_\_\_\_  
Jennifer Lloyd, Secretary

Attest: \_\_\_\_\_  
Rick Dietz, Director  
Information & Technology Services

## IT Department

### BPD Recycle - 2022 - A

Lot ID: 51 Date: 07/08/2022 Recycle

#### Recycle Items List

Asset ID	Asset No.	Serial No.	Name	Category	Division	Date	Recycle Location
4052	1503289C	CQYEN2000774	por1503289C	UPS	Dispatch	02/06/2023	BPD Recycle - 2022 - A
7159	1806222p		1806222p	UPS		02/06/2023	BPD Recycle - 2022 - A
4024	1525575G		POD1525575G	UPS	Detectives	02/06/2023	BPD Recycle - 2022 - A
4026	140434		POD140434	UPS	Detectives	02/06/2023	BPD Recycle - 2022 - A
7158	1804673l		1804673l	UPS		02/06/2023	BPD Recycle - 2022 - A
5163	1704003G		pod1704003G	UPS	Detectives	02/06/2023	BPD Recycle - 2022 - A
7155	13010a		13010a	Monitor		02/06/2023	BPD Recycle - 2022 - A
4017	100154	884483643240	pop100154	LCD 2	Uniformed Officers	02/06/2023	BPD Recycle - 2022 - A
7154	100382		100382	Monitor		02/06/2023	BPD Recycle - 2022 - A
4050	100387		por100387	LCD 3	Dispatch	02/06/2023	BPD Recycle - 2022 - A
3997	070436	CNRXJ88761	pop070436	NetworkPrinter	Uniformed Officers	02/06/2023	BPD Recycle - 2022 - A
4462	070382		070382	NetworkPrinter		02/06/2023	BPD Recycle - 2022 - A
4059	090169		por090169	NetworkPrinter	Dispatch	02/06/2023	BPD Recycle - 2022 - A
1604	1804735	CNRXS14308	Fire 1 Rip and Run HP 4350	NetworkPrinter		02/06/2023	BPD Recycle - 2022 - A
7160	1907251g		1907251g	UPS		02/06/2023	BPD Recycle - 2022 - A
4016	1702755L		POD1702755L	UPS	Detectives	02/06/2023	BPD Recycle - 2022 - A
4215	100001C		POA100001C	UPS	Police Administrator	02/06/2023	BPD Recycle - 2022 - A
7167	675787		box_cables_misc			02/06/2023	BPD Recycle - 2022 - A
7166	1232121		box_keyboards_multi			02/06/2023	BPD Recycle - 2022 - A
4210	060108		poa060108	Monitor	Police Administrator	02/06/2023	BPD Recycle - 2022 - A
7165	1906661c		1906661c	UPS		02/06/2023	BPD Recycle - 2022 - A
7164	170295d		170295d	UPS		02/06/2023	BPD Recycle - 2022 - A
7157	1907251k		1907251k	UPS		02/06/2023	BPD Recycle - 2022 - A
61	130426	27L8BZ1	pop130426	Laptop	Uniformed Officers	02/06/2023	BPD Recycle - 2022 - A
4018	110134		POD110134	UPS	Detectives	02/06/2023	BPD Recycle - 2022 - A
7163	1806222c		1806222c	UPS		02/06/2023	BPD Recycle - 2022 - A
7162	1702950p		1702950p	UPS		02/06/2023	BPD Recycle - 2022 - A
3991	1600525A		POD1600525A	UPS	Detectives	02/06/2023	BPD Recycle - 2022 - A
7161	13017		13017	Monitor		02/06/2023	BPD Recycle - 2022 - A
4012	110157		POD110157	UPS	Detectives	02/06/2023	BPD Recycle - 2022 - A
3998	070347	CNRXC91486	POD070347	NetworkPrinter	Detectives	02/06/2023	BPD Recycle - 2022 - A
1903	1525008j	5T6CW52	pod1525008j	Desktop	Detectives	02/06/2023	BPD Recycle - 2022 - A
7156	1702950j		1702950j	UPS		02/06/2023	BPD Recycle - 2022 - A
2334	1601300A		Monroe-Cam-PC	Desktop	Monroe	02/06/2023	BPD Recycle - 2022 - A
2087	1600481j	G3Z8FB2	poa1600481j	Desktop	Police Administrator	02/06/2023	BPD Recycle - 2022 - A
4936	1703934d	4VWQ0M2	dis1703934d	Desktop	Police Dispatch	02/06/2023	BPD Recycle - 2022 - A
7151	1703933e		1703933e	Desktop		02/06/2023	BPD Recycle - 2022 - A
5967	1600481f		pop1600481f	Desktop	Uniformed Officers	02/06/2023	BPD Recycle - 2022 - A

5553	1600481h	G3YCFB2	pop1600481h	Desktop	Uniformed Officers	02/06/2023	BPD Recycle - 2022 - A
2208	1600481c	G3ZBFB2	poa1600481c	Desktop	Police Administrator	02/06/2023	BPD Recycle - 2022 - A
2072	1600481a	G3ZDFB2	pop1600481a	Desktop	Uniformed Officers	02/06/2023	BPD Recycle - 2022 - A
4905	1703933a	1T5R0M2	pod1703933a	Desktop	Detectives	02/06/2023	BPD Recycle - 2022 - A
7152	1703070c		1703070c	Desktop		02/06/2023	BPD Recycle - 2022 - A
2428	1601468f	3NC7RD2	por1601468f	Desktop	Dispatch	02/06/2023	BPD Recycle - 2022 - A
4902	1703933c	1T6Q0M2	pop1703933c	Desktop	Uniformed Officers	02/06/2023	BPD Recycle - 2022 - A
2440	1601468g	3NBBD2	por1601468g	Desktop	Dispatch	02/03/2023	BPD Recycle - 2022 - A
2430	1601468a	3NC5RD2	por1601468a	Desktop	Dispatch	02/03/2023	BPD Recycle - 2022 - A
2383	1601468c	3NC6RD2	por1601468c	Desktop	Dispatch	02/03/2023	BPD Recycle - 2022 - A
1117	1601468j	3NB6RD2	por1601468j	Desktop	Dispatch	02/03/2023	BPD Recycle - 2022 - A
4935	1703934c	4VWP0M2	dis1703934c	Desktop	Police Dispatch	02/03/2023	BPD Recycle - 2022 - A
2354	1601468e	3NB8RD2	por1601468e	Desktop	Dispatch	02/03/2023	BPD Recycle - 2022 - A
2429	1601468d	3NBCRD2	por1601468d	Desktop	Dispatch	02/03/2023	BPD Recycle - 2022 - A
7148	1703933d		1703933d	Desktop		02/03/2023	BPD Recycle - 2022 - A
7149	1600481g		1600481g	Desktop		02/03/2023	BPD Recycle - 2022 - A
1919	1525008k	5T6HW52	pod1525008k	Desktop	Detectives	02/03/2023	BPD Recycle - 2022 - A
1935	1525008h	5T5JW52	poa1525008h	Desktop	Police Administrator	02/03/2023	BPD Recycle - 2022 - A
7150	1525008L		1525008L	Desktop		02/03/2023	BPD Recycle - 2022 - A
6919	110276		110276	Monitor		07/08/2022	BPD Recycle - 2022 - A
6920	130017		130017	Monitor		07/08/2022	BPD Recycle - 2022 - A
6921	130010a		130010a	Monitor		07/08/2022	BPD Recycle - 2022 - A
3984	030671		POD030671	UPS	Detectives	07/08/2022	BPD Recycle - 2022 - A
6923	1805533m		1805533m	UPS		07/08/2022	BPD Recycle - 2022 - A
6922	1702950n		1702950n			07/08/2022	BPD Recycle - 2022 - A



## Board of Public Works Staff Report

---

**Project/Event:** Contract Service Agreement  
**Petitioner/Representative:** Street Department  
**Staff Representative:** Joe Van Deventer  
**Meeting Date:** February 28, 2023

---

Precision Concrete, Inc., is proposing a saw cut solution (not grinding) for the City of Bloomington, to remove sidewalk trip hazards on sidewalks located in various locations. Trip hazards will be eliminated leaving a maximum running slop (ramp) of 1:8 as permitted to meet ADA requirements. Precision Concrete Services will correct 1,400 trip hazards. This is a continuous project to repair trip hazards within the City.

**Precision Concrete Cutting** **\$ 100,000**

---

**AGREEMENT BETWEEN CITY OF BLOOMINGTON  
PUBLIC WORKS DEPARTMENT AND  
PRECISION CONCRETE, LLC**

This Agreement, entered into on this   22   day of   February  , 20  23  , by and between the City of Bloomington Department of Public Works (the “Department”), and Precision Concrete, LLC (“Contractor”).

**Article 1. Scope of Services** After receiving a **Notice to Proceed**, Contractor shall perform repair and maintenance services of the following types: remove trip hazards from uneven sidewalks and other concrete walkways within the City. Contractor shall diligently provide the Services under this Agreement and shall complete the Services described in this Agreement in a timely manner consistent with the Standard of Care identified in Article 2. Contractor shall complete the Services required under this Agreement on or before December 31, 20  23  , unless the parties mutually agree to a later completion date. Completion shall mean completion of all work related to the Services. In the performance of Contractor’s work, Contractor agrees to maintain such coordination with the Department as may be requested and desirable, including primary coordination with Joe Van Deventer, Director of Street Operations, Public Works Department. Contractor agrees that any information or documents, including digital GIS information, supplied by the Department pursuant to Article 3, below, shall be used by Contractor for this project only, and shall not be reused or reassigned for any other purpose without the written permission of the Department.

**Article 2. Standard of Care** Contractor shall be responsible for completion of the Services in a manner consistent with that degree of care and skill ordinarily exercised by members of the same profession currently practicing under similar circumstances (“Standard of Care”). The Department shall be the sole judge of the adequacy of Contractor’s work in meeting the Standard of Care; however, the Department shall not unreasonably withhold its approval as to the adequacy of Contractor’s performance. Upon notice to Contractor and by mutual agreement between the parties, Contractor will, without additional compensation, correct or replace any and all Services not meeting the Standard of Care.

**Article 3. Responsibilities of the Department** The Department shall provide all necessary information regarding requirements for the Services. The Department shall furnish such information as necessary for the orderly progress of the work, and Contractor shall be entitled to rely upon the accuracy and completeness of such information. The Department’s Project Manager shall act on its behalf with respect to this Agreement.

**Article 4. Compensation** The Department shall pay Contractor for all fees and expenses in an amount not to exceed One Hundred Thousand Dollars (\$100,000.00). Contractor shall submit an invoice to the Department upon the completion of the Services described in Article 1. The invoice shall be sent to: Joe Van Deventer, City of Bloomington Public Works, 401 N. Morton, Suite 120, Bloomington, Indiana 47404. Invoices may be sent via first class mail postage prepaid or via email. Payment will be remitted to Contractor within forty-five (45) days of receipt of invoice. Additional services not set forth in Article 1, or changes in the Services must be authorized in writing by the Department or its designated project coordinator prior to such work being performed, or expenses incurred. The Department shall not make payment for any unauthorized work or expenses.

**Article 5. Appropriation of Funds** Notwithstanding any other provision of this Agreement, if funds for the continued fulfillment of this Agreement by the Department are at any time not forthcoming or are insufficient, through failure of any entity, including the Department itself, to appropriate funds or otherwise, then the Department shall have the right to terminate this Agreement without penalty.

**Article 6. Schedule** Contractor shall perform the Services according to the following schedule: Services will be on as needed basis upon request of the Department. The time limits established by this schedule shall not be exceeded, except for reasonable cause as mutually agreed to by all parties.

**Article 7. Termination** In the event of a party's substantial failure to perform in accordance with the terms of this Agreement, the other party shall have the right to terminate the Agreement upon written notice. The nonperforming party shall have fourteen (14) calendar days from the receipt of the termination notice to cure or to submit a plan for cure acceptable to the other party. Additionally, the Department may terminate or suspend performance of this Agreement at the Department's prerogative at any time upon written notice to Contractor. Contractor shall terminate or suspend performance of the Services on a schedule acceptable to the Department and the Department shall pay the Contractor for all the Services performed up to the date that written notice is received, plus reasonable termination or suspension expenses. Upon restart, an equitable adjustment shall be made to Contractor's compensation and the schedule of services. Upon termination or suspension of this Agreement, all finished or unfinished reports, drawings, collections of data and other documents generated by Contractor in connection with this Agreement shall become the property of the Department, as set forth in Article 9 herein.

**Article 8. Identity of the Contractor** Contractor acknowledges that one of the primary reasons for its selection by the Department to perform the Services is the qualifications and experience of Contractor. Contractor thus agrees that the Services to be performed pursuant to this Agreement shall be performed by Contractor. Contractor shall not subcontract any part of the Services without the prior written permission of the Department. The Department reserves the right to reject any of the Contractor's personnel or proposed outside professional sub-Contractors, and the Department reserves the right to request that acceptable replacement personnel be assigned to the project.

**Article 9. Ownership of Documents and Intellectual Property** All documents, drawings and specifications, including digital format files, prepared by Contractor and furnished to the Department as part of the Services shall become the property of the Department. Contractor shall retain its ownership rights in its design, drawing details, specifications, databases, computer software and other proprietary property. Intellectual property developed, utilized or modified in the performance of the Services shall remain the property of Contractor.

**Article 10. Independent Contractor Status** During the entire term of this Agreement, Contractor shall be an independent contractor, and in no event shall any of its personnel, agents or sub-contractors be construed to be, or represent themselves to be, employees of the Department. Contractor shall be solely responsible for the payment and reporting of all employee and employer taxes, including social security, unemployment, and any other federal, state, or local taxes required to be withheld from employees or payable on behalf of employees.

**Article 11. Indemnification** Contractor shall indemnify and hold harmless the City of Bloomington, the Department, and the officers, agents and employees of the City and the Department from any and all claims, demands, damages, costs, expenses or other liability arising out of the Agreement or occasioned by the reckless or negligent performance of any provision thereof, including, but not limited to, any reckless or negligent act or failure to act or any misconduct on the part of the Contractor or its agents or employees, or any independent contractors directly responsible to it (collectively "Claims").

**Article 12. Insurance** During the performance of any and all Services under this Agreement, Contractor shall maintain the following insurance in full force and effect: a) General Liability Insurance, with a minimum combined single limit of \$1,000,000 for each occurrence and \$2,000,000 in the aggregate; b) Automobile Liability Insurance, with a minimum combined single limit of \$1,000,000 for each person and \$1,000,000 for each accident; c) Workers' Compensation Insurance in accordance with the statutory requirements of Title 22 of the Indiana Code; and d) Professional Liability Insurance ("Errors and Omissions Insurance") with a minimum limit of \$1,000,000 annual aggregate. All insurance policies shall be issued by an insurance company authorized to issue such insurance in the State of Indiana. The City of Bloomington, the Department, and the officers, employees and agents of each shall be named as insureds under the General Liability, Automobile, and Worker's Compensation policies, and such policies shall

stipulate that the insurance will operate as primary insurance and that no other insurance of the City's will be called upon to contribute to a loss hereunder. Contractor shall provide evidence of each insurance policy to the Department prior to the commencement of work under this Agreement.

**Article 13. Conflict of Interest** Contractor declares that it has no present interest, nor shall it acquire any interest, direct or indirect, which would conflict with the performance of Services under this Agreement. Contractor agrees that no person having any such interest shall be employed in the performance of this Agreement.

**Article 14. Waiver** No failure of either party to enforce a term of this Agreement against the other shall be construed as a waiver of that term, nor shall it in any way affect the party's right to enforce that term. No waiver by any party of any term of this Agreement shall be considered to be a waiver of any other term or breach thereof.

**Article 15. Severability** The invalidity, illegality or unenforceability of any provision of this Agreement or the occurrence of any event rendering any portion or provision of this Agreement void shall in no way affect the validity or enforceability of any other portion or provision of this Agreement. Any void provision shall be deemed severed from this Agreement, and the balance of the Agreement shall be construed and enforced as if it did not contain the particular provision to be held void. The parties further agree to amend this Agreement to replace any stricken provision with a valid provision that comes as close as possible to the intent of the stricken provision. The provisions of this Article shall not prevent this entire Agreement from being void should a provision which is of the essence of this Agreement be determined void.

**Article 16. Assignment** Neither the Department nor the Contractor shall assign any rights or duties under this Agreement without the prior written consent of the other party. Unless otherwise stated in the written consent to an assignment, no assignment will release or discharge the assignor from any obligation under this Agreement.

**Article 17. Third Party Rights** Nothing in this Agreement shall be construed to give any rights or benefits to anyone other than the parties.

**Article 18. Governing Law and Venue** This Agreement shall be governed by the laws of the State of Indiana. Venue of any disputes arising under this Agreement shall be in the Monroe Circuit Court, Monroe County, Indiana.

**Article 19. Non-Discrimination** Contractor shall comply with City of Bloomington Ordinance 2.21.020 and all other federal, state and local laws and regulations governing non-discrimination in all regards, including, but not limited to, employment. Contractor understands that the City of Bloomington prohibits its employees from engaging in harassment or discrimination of any kind, including harassing or discriminating against independent contractors doing work for the City. If the Contractor believes that a City employee engaged in such conduct towards Contractor and/or any of its employees, Contractor or its employees may file a complaint with the City department head in charge of the Contractor's work and/or with the City human resources department or the Bloomington Human Rights Commission. The City takes all complaints of harassment and discrimination seriously and will take appropriate disciplinary action if it finds that any City employee engaged in such prohibited conduct.

**Article 20. Compliance with Laws** In performing the Services under this Agreement, Contractor shall comply with any and all applicable federal, state and local statutes, ordinances, plans and regulations, including any and all regulations for protection of the environment. Where such statutes, ordinances, plans or regulations of any public authority having any jurisdiction over the project are in conflict, Contractor shall proceed using its best judgment only after attempting to resolve any such conflict between such

governmental agencies, and shall notify the Department in a timely manner of the conflict, attempts of resolution, and planned course of action.

**Article 21. E-Verify** Contractor is required to enroll in and verify the work eligibility status of all newly-hired employees through the E-Verify program. (This is not required if the E-Verify program no longer exists). Contractor shall sign an affidavit, attached as Exhibit A, affirming that Contractor does not knowingly employ an unauthorized alien. Contractor shall require any subcontractors performing work under this contract to certify to the Contractor that, at the time of certification, the subcontractor does not knowingly employ or contract with an unauthorized alien and the subcontractor has enrolled in and is participating in the E-Verify program. Contractor shall maintain on file all subcontractors' certifications throughout the term of the contract with the City.

**Article 22. Notices** Any notice required by this Agreement shall be made in writing to the individuals/addresses specified below:

**Department:** City of Bloomington Public Works, Attn: Joe Van Deventer, 401 N. Morton, Suite 120, Bloomington, Indiana 47404.

**Contractor:** Precision Concrete, LLC, 1896 Goldeneye Drive, Holland, MI 49424.

Nothing contained in this Article shall be construed to restrict the transmission of routine communications between representatives of the Department and Contractor.

**Article 23. Integration and Modification** This Agreement, including all Exhibits incorporated by reference, represents the entire and integrated agreement between the Department and the Contractor. It supersedes all prior and contemporaneous communications, representations and agreements, whether oral or written, relating to the subject matter of this Agreement. This Agreement may be modified only by a written amendment signed by both parties hereto.

**Article 24. Non-Collusion** Contractor is required to certify that it has not, nor has any other member, representative, or agent of Contractor, entered into any combination, collusion, or agreement with any person relative to the price to be offered by any person nor prevented any person from making an offer nor induced anyone to refrain from making an offer and that this offer is made without reference to any other offer. Contractor shall sign an affidavit, attached hereto as Exhibit B, affirming that Contractor has not engaged in any collusive conduct. Exhibit B is attached hereto and incorporated by reference as though fully set forth.

**Article 25. Living Wage Ordinance** Contractors that are considered "covered employers" under City Ordinance 2.28, otherwise known as the "Living Wage Ordinance," or "LWO," are required to pay their covered employees at least a living wage. Currently, the living wage is \$15.29 per hour for covered employees, and up to 15% of that amount, or \$2.29, may be in the form the covered employer's contribution to health insurance available to the covered employee.

Contractor is determined to be a covered employer under the LWO. Contractor shall execute the Living Wage Ordinance Affidavit, attached as Exhibit C; shall abide by the LWO by paying their employees a living wage; and shall post the Living Wage Poster, provided by the City Legal Department, in areas frequented by their covered employees.

**Article 26. Renewal** This Agreement may be renewed for three additional one-year terms so long as none of the terms and conditions herein are modified in any way. Renewal shall only occur upon advanced written notice by the City to the Contractor that the City wishes to renew the Agreement at least thirty (30) days, but not more than sixty (60) days, prior to the end of the current term



**CITY OF BLOOMINGTON**

---

Beth Cate, Corporation Counsel

**Precision Concrete, LLC**

---

Bonnie K Bonkowski, Chief Financial Officer

**CITY OF BLOOMINGTON PUBLIC WORKS**

---

Adam Wason, Director

---

Kyla Cox Deckard, President, Board of Public Works



**EXHIBIT B**

STATE OF INDIANA )  
 ) SS:  
COUNTY OF \_\_\_\_\_ )

**NON-COLLUSION AFFIDAVIT**

The undersigned offeror or agent, being duly sworn on oath, says that he has not, nor has any other member, representative, or agent of the firm, company, corporation or partnership represented by him, entered into any combination, collusion or agreement with any person relative to the price to be offered by any person nor to prevent any person from making an offer nor to induce anyone to refrain from making an offer and that this offer is made without reference to any other offer.

**OATH AND AFFIRMATION**

I affirm under the penalties of perjury that the foregoing facts and information are true and correct to the best of my knowledge and belief.

Dated this \_\_\_\_\_ day of \_\_\_\_\_, 20\_\_\_\_.

**Precision Concrete, LLC**

By: \_\_\_\_\_  
\_\_\_\_\_

STATE OF INDIANA )  
 ) SS:  
COUNTY OF \_\_\_\_\_ )

Before me, a Notary Public in and for said County and State, personally appeared \_\_\_\_\_ and acknowledged the execution of the foregoing this \_\_\_\_\_ day of \_\_\_\_\_, 2023.

\_\_\_\_\_  
Notary Public Printed Name

\_\_\_\_\_  
Notary Public's Signature

My Commission Expires: \_\_\_\_\_

County of Residence: \_\_\_\_\_

My Commission #: \_\_\_\_\_

**EXHIBIT C**

**AFFIDAVIT THE LIVING WAGE ORDINANCE**

The undersigned, being duly sworn, hereby affirms and says that:

- 1. The undersigned is the [Click here to enter text.](#) of [Click here to enter text.](#)  
(job title) (company name)
- 2. The company named herein that employs the undersigned has contracted with or is seeking to contract with the City of Bloomington to provide services.
- 3. The undersigned hereby states that, to the best of their knowledge and belief, the company named herein is subject to Bloomington City Ordinance 2.28, otherwise known as the "Living Wage Ordinance."
- 4. The projected employment needs under the award include the following: [Click here to enter text.](#)
- 5. The projected net increase or decrease in jobs for covered employees by job title that will result from awarding the assistance: [Click here to enter text.](#)
- 6. The undersigned hereby affirms that the smallest hourly wage to be earned by each of their covered employees shall be at least the living wage.

I affirm under the penalties of perjury that the foregoing facts and information are true and correct to the best of my knowledge and belief.

\_\_\_\_\_  
Signature

\_\_\_\_\_  
Printed name

STATE OF INDIANA )  
 ) SS:  
COUNTY OF \_\_\_\_\_)

Before me, a Notary Public in and for said County and State, personally appeared \_\_\_\_\_  
\_\_\_\_\_ and acknowledged the execution of the foregoing this \_\_\_\_\_ day of \_\_\_\_\_  
\_\_\_\_\_, 2022.

My Commission Expires: \_\_\_\_\_

\_\_\_\_\_  
Notary Public

County of Residence: \_\_\_\_\_

\_\_\_\_\_  
Name Printed

\_\_\_\_\_  
Commission Number



**City of Bloomington  
Human Rights Commission**

TO: BPW  
DATE: February 22, 2023  
RE BIDS FOR: Sidewalk Repair  
DEADLINE: NA

Dear Board Members:

I have reviewed the affirmative action plan for Precision Concrete Cutting, which is on file with the City Legal Department. I find the plan acceptable under the City of Bloomington Human Rights Ordinance and under the Contract Compliance Regulations. I will retain a copy of the plan in my files.

Sincerely,

Audrey Brittingham  
Assistant City Attorney

Cc: File  
Bidder

# NOTICE TO ALL EMPLOYEES WORKING ON CITY-RELATED PROJECTS

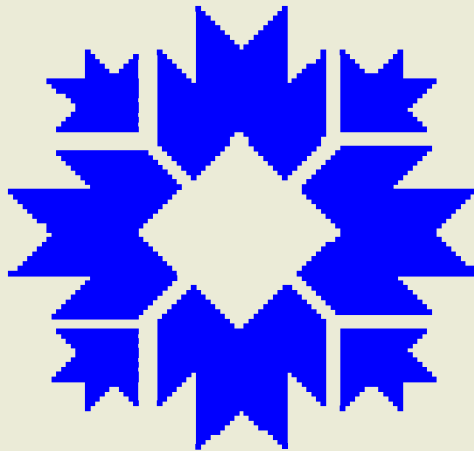

## LIVING WAGE

Your employer may be required to pay you a living wage pursuant to the Bloomington Living Wage Ordinance. There are some exceptions.

If you believe you are not receiving the required pay, contact the Living Wage Ordinance Contract Compliance Officer at the City of Bloomington Legal Department, 812-349-3426 or at [legal@bloomington.in.gov](mailto:legal@bloomington.in.gov).

**REGISTER OF PAYROLL CLAIMS**  
**Board: Board of Public Works Claim Register**

Date:	Type of Claim	FUND	Description	Bank Transfer	Amount
2/24/2023	Payroll				498,697.05
					<u>498,697.05</u>

**ALLOWANCE OF CLAIMS**

We have examined the claims listed on the foregoing register of claims, consisting of 1  
claim, and except for the claims not allowed as shown on the register, such claims are hereby allowed in the  
total amount of \$ 498,697.05

**Dated this 28th day of February year of 2023.**

\_\_\_\_\_

Kyla Cox Deckard, President                      Elizabeth Karon, Vice President                      Jennifer Lloyd, Secretary

I hereby certify that each of the above listed voucher(s) or bill(s) is (are) true and correct and I have audited same in accordance with IC 5-11-10-1.6.

Fiscal Officer \_\_\_\_\_



## STAFF REPORT

Agenda Item: C-7  
Date: 2-24-2023

Administrator  
Review/Approval  
PM

**TO:** Board of Park Commissioners, Board of Public Works  
**FROM:** Haskell Smith, Urban Forester  
**DATE:** February 28, 2023  
**SUBJECT:** MEMORANDUM OF UNDERSTANDING WITH DUKE ENERGY FOR THE DUKE RELIABILITY PROJECT PHASE 2

### Recommendation

Staff recommends approval of a MOU with Duke Energy Incorporated for the upcoming phase of the “Duke Reliability Project” that will connect the transmission lines between the substation on 14<sup>th</sup> and Dunn to the substation at 11<sup>th</sup> and Fairview.

### Background

The City previously worked with Duke Energy to negotiate two prior phases of the Duke Reliability Project to improve electric service reliability in Bloomington. Phase 1 was completed in 2019 and Phase 3 is currently underway. More information, including the route map for the new transmission lines, can be found on Duke’s website: <https://www.duke-energy.com/our-company/about-us/electric-transmission-projects/bloomington-rogers-street>. The installation of transmission lines for Phase II will result in the loss of approximately 16 city-owned “street trees.” Duke Energy has agreed to compensate the City \$6,443.20 for the loss of these trees; this money will be used for street trees in Bloomington with a priority focus on replanting as many as possible along this corridor after the conclusion of the project. This fee was negotiated based on the Urban Forester’s assessed value of the trees to be lost based on species, tree health, and the size of the tree’s diameter at breast height (“dbh”).

The project will also necessitate work in the right-of-way and on trails, and this MOU additionally outlines steps Duke Energy will take to coordinate with the City, including the Board of Park Commissioners and Board of Public Works, for closures and other impacts.

**RESPECTFULLY SUBMITTED,**

A handwritten signature in black ink, appearing to read "Haskell Smith".

Haskell Smith, Urban Forester

2023-January



**MEMORANDUM OF UNDERSTANDING  
BETWEEN CITY OF BLOOMINGTON AND  
DUKE ENERGY INDIANA, LLC  
FOR RESPONSIBILITIES REGARDING THE  
“2023 DUKE RELIABILITY PROJECT PHASE 2”**

**THIS MEMORANDUM OF UNDERSTANDING** is entered into by and between the City of Bloomington, acting through its Board of Park Commissioners and Board of Public Works (“City”) and Duke Energy Indiana, LLC (“DEI”).

**WHEREAS**, DEI is engaging in a capital project to connect transmission lines between the intersections of 17<sup>th</sup> & Jackson Streets and N. Dunn and 14<sup>th</sup> Streets (the “Project”); and

**WHEREAS**, the completion of the Project will necessitate location of electric facilities in public rights-of-way (“ROW”) along roads and adjacent to trails; and

**WHEREAS**, as part of the use of the public ROW, DEI will comply with the City’s permitting process for work within the public ROW, including Maintenance of Traffic plans for land, road, and trail closures. Road closures and restrictions will be approved through the City’s Engineering Department, and trail closures and restrictions will be approved through the Parks and Recreation Department; and

**WHEREAS**, the City will not unduly or unreasonably interfere with the permitting process as described above; and

**WHEREAS**, the use of the public ROW will result in the removal of existing trees in the public ROWs which may result in public comments/complaints to DEI or the City; and

**WHEREAS**, each of the Parties agrees to undertake certain aspects of the work related to the use of the public ROW as set forth below;

**NOW, THEREFORE**, in consideration of the foregoing and other valuable consideration set forth below, which the Parties acknowledge as sufficient, the Parties agree as follows:

1. **DEI OBLIGATIONS**: DEI shall, as part of its work on the Project in the public ROW:
  - a. Issue a press release, prepared in conjunction with the City, that the City has approved the Project’s use of public ROW, the Project itself, including its purpose, scope and impact on the public ROW, and that the Project will necessitate the removal of specified City-owned trees in the public ROW;
  - b. Safely remove all City-owned trees (as identified by the City as City-owned) that in the reasonable exercise of DEI’s judgment must be removed to complete the Project;
  - c. Remove vegetation debris caused by the tree removal work described in subparagraph 1(a);

- d. Grind stumps of any City-owned trees that are removed in accordance with subparagraph 1(a);
- e. Respond to any comments or complaints by the public to DEI about the use of the public ROW for the Project, which responses shall not denigrate or negatively portray the Project, the use of the public ROW, or the City; and
- f. Make a one-time payment of six thousand four hundred forty three dollars and twenty cents (\$6,443.20) to the City within thirty (30) business days of the commencement of the Project construction to assist the City in replanting approved vegetation at the conclusion of the Project, in place of trees removed in accordance with subparagraph 1(a).

2. CITY OBLIGATIONS: The City shall:

- a. Purchase and replant vegetation in the public ROW corridors after the completion of all activities by DEI and its subcontractors, provided that any vegetation the City chooses must meet NESC regulations and DEI vegetation guidelines, with the exception that DEI will permit the City to choose and plant trees pursuant to this Section 2a with a maximum maturity height of twenty feet (20') even though this height varies from the DEI vegetation guidelines;
- b. Remain solely responsible for the care and maintenance of any vegetation planted by it in the public ROW pursuant to this Agreement. However, DEI, in its sole discretion, may maintain, trim or remove such vegetation in the public ROW in accordance with utility vegetation management guidelines; and
- c. Respond to any comments or complaints by the public to the City about the use of the public ROW for the Project, which responses shall not denigrate or negatively portray the Project, the use of the public ROW, or DEI.

3. This Memorandum of Understanding may be executed in counterparts, each of which shall be deemed an original, but all of which together shall constitute one and the same instrument.

4. This Memorandum of Understanding will remain valid and in effect for a period of one year from the date of Project commencement of construction.

**IN WITNESS WHEREOF**, the parties hereto have executed this Memorandum of Understanding which shall become effective as of the date last entered below.

**CITY OF BLOOMINGTON**

**DUKE ENERGY INDIANA, LLC**

\_\_\_\_\_  
Kathleen Mills, President  
Board of Park Commissioners

\_\_\_\_\_  
Dawn M. Brunk, Project Manager, I

\_\_\_\_\_  
Date

\_\_\_\_\_  
Date

\_\_\_\_\_  
Paula McDevitt, Director  
City of Bloomington Parks and Recreation

\_\_\_\_\_  
Date

\_\_\_\_\_  
Kyla Cox Deckard, President  
Board of Public Works

\_\_\_\_\_  
Date

\_\_\_\_\_  
Beth Cate, Corporation Counsel

\_\_\_\_\_  
Date



# Board of Public Works

## Staff Report

---

**Project/Event:** Change Order #9 for the 7<sup>th</sup> Street Protected Bike Lane Project.  
**Petitioner/Representative:** Engineering Department  
**Staff Representative:** Roy Aten, Senior Project Manager  
**Date:** 02/28/2022

---

**Report:**

This project was awarded on May 11<sup>th</sup>, 2021 to Milestone Contractors in the amount of \$2,572,455.00. The project constructed a protected bike lane along 7th Street from the B-Line Trail to Woodlawn Avenue. There have been a total of eight change orders approved for a final authorized amount of \$2,662,250.65. This final change order will balance the final quantities for the project and will result in a deduct of \$192,095.69, for a final contract amount of \$2,470,154.96. This project is funded through the Bicentennial Bond 2018 Series A and B.

## City of Bloomington Contract and Purchase Justification Form

Vendor: Milestone Contractors, LP

Contract Amount: \$2,662,250.65

This form should be completed and attached to the contract documents and forwarded to the Legal Department Attorney assigned to your Department. Contracts will not be approved by the Controller if a completed form is not included with the contract documents.

### PURCHASE INFORMATION

1. Check the box beside the procurement method used to initiate this procurement: (Attach a quote or bid tabulation if applicable)

<input type="checkbox"/> Request for Quote (RFQ)	<input type="checkbox"/> Request for Proposal (RFP)	<input type="checkbox"/> Sole Source	<input checked="" type="checkbox"/> Not Applicable (NA)
<input type="checkbox"/> Invitation to Bid (ITB)	<input type="checkbox"/> Request for Qualifications (RFQu)	<input type="checkbox"/> Emergency Purchase	

2. List the results of procurement process. Give further explanation where requested.

	Yes	No	
# of Submittals: 1			Was the lowest cost selected? (If no, please state below why it was not.)
Met city requirements?	<input checked="" type="checkbox"/>	<input type="checkbox"/>	<input checked="" type="checkbox"/> Yes <input type="checkbox"/> No
Met item or need requirements?	<input checked="" type="checkbox"/>	<input type="checkbox"/>	Contract awarded May 11th, 2021 through the Board of Public Works
Was an evaluation team used?	<input type="checkbox"/>	<input checked="" type="checkbox"/>	
Was scoring grid used?	<input type="checkbox"/>	<input checked="" type="checkbox"/>	
Were vendor presentations requested?	<input type="checkbox"/>	<input checked="" type="checkbox"/>	

3. State why this vendor was selected to receive the award and contract:

Contract BC-2021-47-CN was approved by the Board of Public Works on May 11th, 2021. This Change Order is being presented in compliance with the contract documents for the 7th Street Protected Bike Lane Project.

Award	\$2,572,455.00
Previous change Orders	\$89,795.65
Change Order #9	-\$192,095.69
Final contract	\$2,470,154.96

Roy Aten

---

Print/Type Name

Senior Project Manager

---

Print/Type Title

Engineering

---

Department



# City of Bloomington, Indiana

## Change Order Details

### 7th Street Protected Bike Lane Improvements

---

<b>Description</b>	Contract: BC-2021-47-CN Installation of a protected bike lane along 7th Street from the B-Line Trail to Woodlawn Avenue.
<b>Prime Contractor</b>	Milestone Contractors, L.P 3301 S. 460 E. Laffayette, IN
<b>Change Order</b>	9
<b>Status</b>	Pending
<b>Date Created</b>	12/12/2022
<b>Summary</b>	Balancing Change Order for Final Payment
<b>Change Order Description</b>	Balancing Change Order for Final Payment
<b>Awarded Project Amount</b>	\$2,572,455.00
<b>Authorized Project Amount</b>	\$2,662,250.65
<b>Change Order Amount</b>	-\$192,095.69
<b>Revised Project Amount</b>	\$2,470,154.96

## Increases/Decreases

Line Number	Item ID	Unit	Unit Price	Current		Change		Revised	
				Quantity	Amount	Quantity	Amount	Quantity	Amount

### Section: 1 - Description

0002	109-08359	DOL	\$1.000	1.000	\$1.00	-1.000	-\$1.00	0.000	\$0.00
------	-----------	-----	---------	-------	--------	--------	---------	-------	--------

LIQUIDATED DAMAGES

**Reason:** Balancing Change Order

#### Funding Details

Protected Bike Lane	1.000	\$1.00	-1.000	-\$1.00	0.000	\$0.00
Rain Gardens	0.000	\$0.00	0.000	\$0.00	0.000	\$0.00

0006	202-02240	SYS	\$30.000	1,710.000	\$51,300.00	567.740	\$17,032.20	2,277.740	\$68,332.20
------	-----------	-----	----------	-----------	-------------	---------	-------------	-----------	-------------

PAVEMENT REMOVAL

**Reason:** Balancing Change Order

#### Funding Details

Protected Bike Lane	1,710.000	\$51,300.00	567.740	\$17,032.20	2,277.740	\$68,332.20
Rain Gardens	0.000	\$0.00	0.000	\$0.00	0.000	\$0.00

0007	202-02637	LFT	\$25.000	155.000	\$3,875.00	-155.000	-\$3,875.00	0.000	\$0.00
------	-----------	-----	----------	---------	------------	----------	-------------	-------	--------

PIPE ABANDON AND GROUT FILL

**Reason:** Balancing Change Order



Line Number	Item ID	Unit	Unit Price	Current		Change		Revised	
				Quantity	Amount	Quantity	Amount	Quantity	Amount
				<b>Funding Details</b>					
			Protected Bike Lane	155.000	\$3,875.00	-155.000	-\$3,875.00	0.000	\$0.00
			Rain Gardens	0.000	\$0.00	0.000	\$0.00	0.000	\$0.00
0008	203-02000	CYS	\$53.100	2,080.000	\$110,448.00	-27.710	-\$1,471.40	2,052.290	\$108,976.60
EXCAVATION, COMMON									
<b>Reason:</b> Balancing Change Order									
				<b>Funding Details</b>					
			Protected Bike Lane	1,763.000	\$93,615.30	-0.710	-\$37.70	1,762.290	\$93,577.60
			Rain Gardens	317.000	\$16,832.70	-27.000	-\$1,433.70	290.000	\$15,399.00
0009	205-12108	DOL	\$1.000	7,000.000	\$7,000.00	-2,813.000	-\$2,813.00	4,187.000	\$4,187.00
STORM WATER MANAGEMENT BUDGET									
<b>Reason:</b> Balancing Change Order									
				<b>Funding Details</b>					
			Protected Bike Lane	7,000.000	\$7,000.00	-2,813.000	-\$2,813.00	4,187.000	\$4,187.00
			Rain Gardens	0.000	\$0.00	0.000	\$0.00	0.000	\$0.00
010	207-08264	SYS	\$30.000	1,120.000	\$33,600.00	-385.500	-\$11,565.00	734.500	\$22,035.00
SUBGRADE TREATMENT, TYPE II									
<b>Reason:</b> Balancing Change Order									



Line Number	Item ID	Unit	Unit Price	Current		Change		Revised	
				Quantity	Amount	Quantity	Amount	Quantity	Amount
				<b>Funding Details</b>					
			Protected Bike Lane	1,120.000	\$33,600.00	-385.500	-\$11,565.00	734.500	\$22,035.00
			Rain Gardens	0.000	\$0.00	0.000	\$0.00	0.000	\$0.00
011	207-09935	SYS	\$57.000	1,049.000	\$59,793.00	220.330	\$12,558.81	1,269.330	\$72,351.81
SUBGRADE TREATMENT, TYPE IC									
<b>Reason:</b> Balancing Change Order									
				<b>Funding Details</b>					
			Protected Bike Lane	1,049.000	\$59,793.00	220.330	\$12,558.81	1,269.330	\$72,351.81
			Rain Gardens	0.000	\$0.00	0.000	\$0.00	0.000	\$0.00
012	211-09265	CYS	\$61.000	68.000	\$4,148.00	-0.380	-\$23.18	67.620	\$4,124.82
STRUCTURE BACKFILL, TYPE 2									
<b>Reason:</b> Balancing Change Order									
				<b>Funding Details</b>					
			Protected Bike Lane	68.000	\$4,148.00	-0.380	-\$23.18	67.620	\$4,124.82
			Rain Gardens	0.000	\$0.00	0.000	\$0.00	0.000	\$0.00
013	301-12234	CYS	\$110.000	326.000	\$35,860.00	-266.010	-\$29,261.10	59.990	\$6,598.90
COMPACTED AGGREGATE NO 53									
<b>Reason:</b> Balancing Change Order									

Line Number	Item ID	Unit	Unit Price	Current		Change		Revised	
				Quantity	Amount	Quantity	Amount	Quantity	Amount
				<b>Funding Details</b>					
			Protected Bike Lane	326.000	\$35,860.00	-266.010	-\$29,261.10	59.990	\$6,598.90
			Rain Gardens	0.000	\$0.00	0.000	\$0.00	0.000	\$0.00
014	302-07455	CYS	\$315.000	22.000	\$6,930.00	-1.550	-\$488.25	20.450	\$6,441.75
DENSE GRADED SUBBASE									
<b>Reason:</b> Balancing Change Order									
				<b>Funding Details</b>					
			Protected Bike Lane	22.000	\$6,930.00	-1.550	-\$488.25	20.450	\$6,441.75
			Rain Gardens	0.000	\$0.00	0.000	\$0.00	0.000	\$0.00
015	304-07491	TON	\$169.000	390.000	\$65,910.00	-390.000	-\$65,910.00	0.000	\$0.00
HMA PATCHING, TYPE C									
<b>Reason:</b> Balancing Change Order									
				<b>Funding Details</b>					
			Protected Bike Lane	390.000	\$65,910.00	-390.000	-\$65,910.00	0.000	\$0.00
			Rain Gardens	0.000	\$0.00	0.000	\$0.00	0.000	\$0.00
016	306-08034	SYS	\$2.500	14,450.000	\$36,125.00	-332.500	-\$831.25	14,117.500	\$35,293.75
MILLING, ASPHALT, 1 1/2 IN.									
<b>Reason:</b> Balancing Change Order									

Line Number	Item ID	Unit	Unit Price	Current		Change		Revised	
				Quantity	Amount	Quantity	Amount	Quantity	Amount
				<b>Funding Details</b>					
			Protected Bike Lane	14,450.000	\$36,125.00	-332.500	-\$831.25	14,117.500	\$35,293.75
			Rain Gardens	0.000	\$0.00	0.000	\$0.00	0.000	\$0.00
017	401-10258	LFT	\$0.520	6,370.000	\$3,312.40	-6,370.000	-\$3,312.40	0.000	\$0.00
JOINT ADHESIVE, SURFACE									
<b>Reason:</b> Balancing Change Order									
				<b>Funding Details</b>					
			Protected Bike Lane	6,370.000	\$3,312.40	-6,370.000	-\$3,312.40	0.000	\$0.00
			Rain Gardens	0.000	\$0.00	0.000	\$0.00	0.000	\$0.00
018	401-10259	LFT	\$9.540	105.000	\$1,001.70	-105.000	-\$1,001.70	0.000	\$0.00
JOINT ADHESIVE, INTERMEDIATE									
<b>Reason:</b> Balancing Change Order									
				<b>Funding Details</b>					
			Protected Bike Lane	105.000	\$1,001.70	-105.000	-\$1,001.70	0.000	\$0.00
			Rain Gardens	0.000	\$0.00	0.000	\$0.00	0.000	\$0.00
019	401-11785	LFT	\$0.350	6,370.000	\$2,229.50	-6,370.000	-\$2,229.50	0.000	\$0.00
LIQUID ASPHALT SEALANT									
<b>Reason:</b> Balancing Change Order									



Line Number	Item ID	Unit	Unit Price	Current		Change		Revised		
				Quantity	Amount	Quantity	Amount	Quantity	Amount	
				<b>Funding Details</b>						
				Protected Bike Lane	6,370.000	\$2,229.50	-6,370.000	-\$2,229.50	0.000	\$0.00
				Rain Gardens	0.000	\$0.00	0.000	\$0.00	0.000	\$0.00
020	402-07434	TON	\$133.150	1,425.000	\$189,738.75	378.680	\$50,421.24	1,803.680	\$240,159.99	
HMA SURFACE, TYPE C										
<b>Reason:</b> Balancing Change Order										
				<b>Funding Details</b>						
				Protected Bike Lane	1,425.000	\$189,738.75	378.680	\$50,421.24	1,803.680	\$240,159.99
				Rain Gardens	0.000	\$0.00	0.000	\$0.00	0.000	\$0.00
022	402-07442	TON	\$173.500	340.000	\$58,990.00	-190.790	-\$33,102.07	149.210	\$25,887.93	
HMA BASE, TYPE C										
<b>Reason:</b> Balancing Change Order										
				<b>Funding Details</b>						
				Protected Bike Lane	340.000	\$58,990.00	-190.790	-\$33,102.07	149.210	\$25,887.93
				Rain Gardens	0.000	\$0.00	0.000	\$0.00	0.000	\$0.00
023	406-05521	SYS	\$0.170	17,745.000	\$3,016.65	-7,421.200	-\$1,261.60	10,323.800	\$1,755.05	
ASPHALT FOR TACK COAT										
<b>Reason:</b> Balancing Change Order										

Line Number	Item ID	Unit	Unit Price	Current		Change		Revised	
				Quantity	Amount	Quantity	Amount	Quantity	Amount
				<b>Funding Details</b>					
			Protected Bike Lane	17,745.000	\$3,016.65	-7,421.200	-\$1,261.60	10,323.800	\$1,755.05
			Rain Gardens	0.000	\$0.00	0.000	\$0.00	0.000	\$0.00
024	502-09531	SYS	\$195.850	141.000	\$27,614.85	110.560	\$21,653.18	251.560	\$49,268.03
PCCP, PEDESTRIAN CROSSINGS									
<b>Reason:</b> Balancing Change Order									
				<b>Funding Details</b>					
			Protected Bike Lane	141.000	\$27,614.85	110.560	\$21,653.18	251.560	\$49,268.03
			Rain Gardens	0.000	\$0.00	0.000	\$0.00	0.000	\$0.00
025	506-06333	SYS	\$71.000	940.000	\$66,740.00	129.150	\$9,169.65	1,069.150	\$75,909.65
PCCP PATCHING, FULL DEPTH									
<b>Reason:</b> Balancing Change Order									
				<b>Funding Details</b>					
			Protected Bike Lane	940.000	\$66,740.00	129.150	\$9,169.65	1,069.150	\$75,909.65
			Rain Gardens	0.000	\$0.00	0.000	\$0.00	0.000	\$0.00
026	604-06070	SYS	\$148.500	375.000	\$55,687.50	75.580	\$11,223.63	450.580	\$66,911.13
SIDEWALK CONCRETE, 4 IN									
<b>Reason:</b> Balancing Change Order									

Line Number	Item ID	Unit	Unit Price	Current		Change		Revised	
				Quantity	Amount	Quantity	Amount	Quantity	Amount
				<b>Funding Details</b>					
			Protected Bike Lane	375.000	\$55,687.50	75.580	\$11,223.63	450.580	\$66,911.13
			Rain Gardens	0.000	\$0.00	0.000	\$0.00	0.000	\$0.00
028	604-12083	SYS	\$321.000	135.000	\$43,335.00	-18.670	-\$5,993.07	116.330	\$37,341.93
DETECTABLE WARNING SURFACES									
<b>Reason:</b> Balancing Change Order									
				<b>Funding Details</b>					
			Protected Bike Lane	135.000	\$43,335.00	-18.670	-\$5,993.07	116.330	\$37,341.93
			Rain Gardens	0.000	\$0.00	0.000	\$0.00	0.000	\$0.00
030	604-07824	SYS	\$155.000	608.500	\$94,317.50	-55.030	-\$8,529.65	553.470	\$85,787.85
STAMPED CONCRETE, 6 IN									
<b>Reason:</b> Balancing Change Order									
				<b>Funding Details</b>					
			Protected Bike Lane	608.500	\$94,317.50	-55.030	-\$8,529.65	553.470	\$85,787.85
			Rain Gardens	0.000	\$0.00	0.000	\$0.00	0.000	\$0.00
031	604-07825	SYS	\$167.000	310.000	\$51,770.00	-30.010	-\$5,011.67	279.990	\$46,758.33
STAMPED CONCRETE, 10 IN									
<b>Reason:</b> Balancing Change Order									



Line Number	Item ID	Unit	Unit Price	Current		Change		Revised	
				Quantity	Amount	Quantity	Amount	Quantity	Amount

**Funding Details**

Protected Bike Lane	310.000	\$51,770.00	-30.010	-\$5,011.67	279.990	\$46,758.33
Rain Gardens	0.000	\$0.00	0.000	\$0.00	0.000	\$0.00

032	605-06120	LFT	\$39.250	6,725.000	\$263,956.25	-1,062.050	-\$41,685.46	5,662.950	\$222,270.79
-----	-----------	-----	----------	-----------	--------------	------------	--------------	-----------	--------------

CURB, CONCRETE (VERTICAL)

**Reason:** Balancing Change Order

**Funding Details**

Protected Bike Lane	6,725.000	\$263,956.25	-1,062.050	-\$41,685.46	5,662.950	\$222,270.79
Rain Gardens	0.000	\$0.00	0.000	\$0.00	0.000	\$0.00

033	605-06235	LFT	\$100.750	987.000	\$99,440.25	3.000	\$302.25	990.000	\$99,742.50
-----	-----------	-----	-----------	---------	-------------	-------	----------	---------	-------------

CENTER CURB, D CONCRETE MODIFIED

**Reason:** Balancing Change Order

**Funding Details**

Protected Bike Lane	987.000	\$99,440.25	3.000	\$302.25	990.000	\$99,742.50
Rain Gardens	0.000	\$0.00	0.000	\$0.00	0.000	\$0.00

035	605-90726	LFT	\$40.000	1,090.000	\$43,600.00	199.030	\$7,961.20	1,289.030	\$51,561.20
-----	-----------	-----	----------	-----------	-------------	---------	------------	-----------	-------------

CURB, CONCRETE B (DEPRESSED)

**Reason:** Balancing Change Order

Line Number	Item ID	Unit	Unit Price	Current		Change		Revised	
				Quantity	Amount	Quantity	Amount	Quantity	Amount
				<b>Funding Details</b>					
			Protected Bike Lane	1,090.000	\$43,600.00	199.030	\$7,961.20	1,289.030	\$51,561.20
			Rain Gardens	0.000	\$0.00	0.000	\$0.00	0.000	\$0.00
036	610-08446	SYS	\$186.750	140.000	\$26,145.00	-0.370	-\$69.10	139.630	\$26,075.90
PCCP FOR APPROACHES, 6 IN.									
<b>Reason:</b> Balancing Change Order									
				<b>Funding Details</b>					
			Protected Bike Lane	140.000	\$26,145.00	-0.370	-\$69.10	139.630	\$26,075.90
			Rain Gardens	0.000	\$0.00	0.000	\$0.00	0.000	\$0.00
039	616-11736	TON	\$80.500	42.000	\$3,381.00	77.400	\$6,230.70	119.400	\$9,611.70
DECORATIVE STONE									
<b>Reason:</b> Balancing Change Order									
				<b>Funding Details</b>					
			Protected Bike Lane	0.000	\$0.00	0.000	\$0.00	0.000	\$0.00
			Rain Gardens	42.000	\$3,381.00	77.400	\$6,230.70	119.400	\$9,611.70
040	301-12233	TON	\$49.590	57.000	\$2,826.63	-17.360	-\$860.88	39.640	\$1,965.75
COMPACTED AGGREGATE NO 8									
<b>Reason:</b> Balancing Change Order									



Line Number	Item ID	Unit	Unit Price	Current		Change		Revised	
				Quantity	Amount	Quantity	Amount	Quantity	Amount

**Funding Details**

Protected Bike Lane	0.000	\$0.00	0.000	\$0.00	0.000	\$0.00
Rain Gardens	57.000	\$2,826.63	-17.360	-\$860.88	39.640	\$1,965.75

041	401-93813	TON	\$206.500	30.000	\$6,195.00	11.110	\$2,294.22	41.110	\$8,489.22
-----	-----------	-----	-----------	--------	------------	--------	------------	--------	------------

SAND (ASTM C33)

**Reason:** Balancing Change Order

**Funding Details**

Protected Bike Lane	0.000	\$0.00	0.000	\$0.00	0.000	\$0.00
Rain Gardens	30.000	\$6,195.00	11.110	\$2,294.22	41.110	\$8,489.22

042	621-09908	CYS	\$212.000	133.000	\$28,196.00	-3.000	-\$636.00	130.000	\$27,560.00
-----	-----------	-----	-----------	---------	-------------	--------	-----------	---------	-------------

BIOSOIL

**Reason:** Balancing Change Order

**Funding Details**

Protected Bike Lane	0.000	\$0.00	0.000	\$0.00	0.000	\$0.00
Rain Gardens	133.000	\$28,196.00	-3.000	-\$636.00	130.000	\$27,560.00

043	621-06570	CYS	\$116.000	23.000	\$2,668.00	10.000	\$1,160.00	33.000	\$3,828.00
-----	-----------	-----	-----------	--------	------------	--------	------------	--------	------------

PLANTING SOIL MIX

**Reason:** Balancing Change Order

Line Number	Item ID	Unit	Unit Price	Current		Change		Revised	
				Quantity	Amount	Quantity	Amount	Quantity	Amount
				<b>Funding Details</b>					
			Protected Bike Lane	0.000	\$0.00	0.000	\$0.00	0.000	\$0.00
			Rain Gardens	23.000	\$2,668.00	10.000	\$1,160.00	33.000	\$3,828.00
045	621-06575	SYS	\$41.500	168.000	\$6,972.00	80.600	\$3,344.90	248.600	\$10,316.90
SODDING, NURSERY									
<b>Reason:</b> Balancing Change Order									
				<b>Funding Details</b>					
			Protected Bike Lane	168.000	\$6,972.00	80.600	\$3,344.90	248.600	\$10,316.90
			Rain Gardens	0.000	\$0.00	0.000	\$0.00	0.000	\$0.00
048	622-05650	EACH	\$605.000	34.000	\$20,570.00	1.000	\$605.00	35.000	\$21,175.00
PLANT, DECIDUOUS TREE, SINGLE STEM, OVER 2 IN. TO 2.5 IN.									
<b>Reason:</b> Balancing Change Order									
				<b>Funding Details</b>					
			Protected Bike Lane	34.000	\$20,570.00	1.000	\$605.00	35.000	\$21,175.00
			Rain Gardens	0.000	\$0.00	0.000	\$0.00	0.000	\$0.00
051	715-05149	LFT	\$59.500	360.000	\$21,420.00	-104.000	-\$6,188.00	256.000	\$15,232.00
PIPE, TYPE 2, CIRCULAR, 12 IN.									
<b>Reason:</b> Balancing Change Order									

Line Number	Item ID	Unit	Unit Price	Current		Change		Revised	
				Quantity	Amount	Quantity	Amount	Quantity	Amount

**Funding Details**

Protected Bike Lane	360.000	\$21,420.00	-104.000	-\$6,188.00	256.000	\$15,232.00
Rain Gardens	0.000	\$0.00	0.000	\$0.00	0.000	\$0.00

053	720-44000	EACH	\$522.000	6.000	\$3,132.00	7.000	\$3,654.00	13.000	\$6,786.00
-----	-----------	------	-----------	-------	------------	-------	------------	--------	------------

CASTING, ADJUST TO GRADE

**Reason:** Balancing Change Order

**Funding Details**

Protected Bike Lane	6.000	\$3,132.00	7.000	\$3,654.00	13.000	\$6,786.00
Rain Gardens	0.000	\$0.00	0.000	\$0.00	0.000	\$0.00

0054	720-45042	EACH	\$3,005.000	3.000	\$9,015.00	-2.000	-\$6,010.00	1.000	\$3,005.00
------	-----------	------	-------------	-------	------------	--------	-------------	-------	------------

INLET, HA5

**Reason:** Balancing Change Order

**Funding Details**

Protected Bike Lane	3.000	\$9,015.00	-2.000	-\$6,010.00	1.000	\$3,005.00
Rain Gardens	0.000	\$0.00	0.000	\$0.00	0.000	\$0.00

054	720-45270	EACH	\$2,905.000	9.000	\$26,145.00	-5.000	-\$14,525.00	4.000	\$11,620.00
-----	-----------	------	-------------	-------	-------------	--------	--------------	-------	-------------

PIPE CATCH BASIN, 18 IN.

**Reason:** Balancing Change Order



Line Number	Item ID	Unit	Unit Price	Current		Change		Revised	
				Quantity	Amount	Quantity	Amount	Quantity	Amount

**Funding Details**

Protected Bike Lane	5.000	\$14,525.00	-5.000	-\$14,525.00	0.000	\$0.00
Rain Gardens	4.000	\$11,620.00	0.000	\$0.00	4.000	\$11,620.00

055	720-45410	EACH	\$3,055.000	4.000	\$12,220.00	-3.000	-\$9,165.00	1.000	\$3,055.00
-----	-----------	------	-------------	-------	-------------	--------	-------------	-------	------------

MANHOLE, C4

**Reason:** Balancing Change Order

**Funding Details**

Protected Bike Lane	4.000	\$12,220.00	-3.000	-\$9,165.00	1.000	\$3,055.00
Rain Gardens	0.000	\$0.00	0.000	\$0.00	0.000	\$0.00

057	720-97008	EACH	\$5,150.000	2.000	\$10,300.00	-2.000	-\$10,300.00	0.000	\$0.00
-----	-----------	------	-------------	-------	-------------	--------	--------------	-------	--------

FIRE HYDRANT ASSEMBLY RELOCATE

**Reason:** Balancing Change Order

**Funding Details**

Protected Bike Lane	2.000	\$10,300.00	-2.000	-\$10,300.00	0.000	\$0.00
Rain Gardens	0.000	\$0.00	0.000	\$0.00	0.000	\$0.00

058	720-98174	EACH	\$2,955.000	8.000	\$23,640.00	-2.000	-\$5,910.00	6.000	\$17,730.00
-----	-----------	------	-------------	-------	-------------	--------	-------------	-------	-------------

INLET, B15

**Reason:** Balancing Change Order

Line Number	Item ID	Unit	Unit Price	Current		Change		Revised	
				Quantity	Amount	Quantity	Amount	Quantity	Amount
				<b>Funding Details</b>					
			Protected Bike Lane	8.000	\$23,640.00	-2.000	-\$5,910.00	6.000	\$17,730.00
			Rain Gardens	0.000	\$0.00	0.000	\$0.00	0.000	\$0.00
059	720-98555	EACH	\$3,133.000	6.000	\$18,798.00	-4.000	-\$12,532.00	2.000	\$6,266.00
INLET, C15									
<b>Reason:</b> Balancing Change Order									
				<b>Funding Details</b>					
			Protected Bike Lane	6.000	\$18,798.00	-4.000	-\$12,532.00	2.000	\$6,266.00
			Rain Gardens	0.000	\$0.00	0.000	\$0.00	0.000	\$0.00
060	801-01093	EACH	\$775.000	2.000	\$1,550.00	-2.000	-\$1,550.00	0.000	\$0.00
TEMPORARY WORKSITE SPEED LIMIT SIGN ASSEMBLY									
<b>Reason:</b> Balancing Change Order									
				<b>Funding Details</b>					
			Protected Bike Lane	2.000	\$1,550.00	-2.000	-\$1,550.00	0.000	\$0.00
			Rain Gardens	0.000	\$0.00	0.000	\$0.00	0.000	\$0.00
062	801-04308	EACH	\$370.000	15.000	\$5,550.00	-7.000	-\$2,590.00	8.000	\$2,960.00
ROAD CLOSURE SIGN ASSEMBLY									
<b>Reason:</b> Balancing Change Order									

Line Number	Item ID	Unit	Unit Price	Current		Change		Revised	
				Quantity	Amount	Quantity	Amount	Quantity	Amount
				<b>Funding Details</b>					
			Protected Bike Lane	15.000	\$5,550.00	-7.000	-\$2,590.00	8.000	\$2,960.00
			Rain Gardens	0.000	\$0.00	0.000	\$0.00	0.000	\$0.00
063	801-06625	EACH	\$145.000	36.000	\$5,220.00	-18.000	-\$2,610.00	18.000	\$2,610.00
DETOUR ROUTE MARKER ASSEMBLY									
<b>Reason:</b> Balancing Change Order									
				<b>Funding Details</b>					
			Protected Bike Lane	36.000	\$5,220.00	-18.000	-\$2,610.00	18.000	\$2,610.00
			Rain Gardens	0.000	\$0.00	0.000	\$0.00	0.000	\$0.00
065	801-06645	EACH	\$105.000	25.000	\$2,625.00	-20.000	-\$2,100.00	5.000	\$525.00
CONSTRUCTION SIGN, B									
<b>Reason:</b> Balancing Change Order									
				<b>Funding Details</b>					
			Protected Bike Lane	25.000	\$2,625.00	-20.000	-\$2,100.00	5.000	\$525.00
			Rain Gardens	0.000	\$0.00	0.000	\$0.00	0.000	\$0.00
067	801-07118	LFT	\$15.000	324.000	\$4,860.00	28.000	\$420.00	352.000	\$5,280.00
BARRICADE, III-A									
<b>Reason:</b> Balancing Change Order									



Line Number	Item ID	Unit	Unit Price	Current		Change		Revised	
				Quantity	Amount	Quantity	Amount	Quantity	Amount
				<b>Funding Details</b>					
			Protected Bike Lane	324.000	\$4,860.00	28.000	\$420.00	352.000	\$5,280.00
			Rain Gardens	0.000	\$0.00	0.000	\$0.00	0.000	\$0.00
068	802-05701	LFT	\$20.000	208.000	\$4,160.00	151.500	\$3,030.00	359.500	\$7,190.00
SIGN POST, SQUARE TYPE 1 REINFORCED ANCHOR BASE									
<b>Reason:</b> Balancing Change Order									
				<b>Funding Details</b>					
			Protected Bike Lane	208.000	\$4,160.00	151.500	\$3,030.00	359.500	\$7,190.00
			Rain Gardens	0.000	\$0.00	0.000	\$0.00	0.000	\$0.00
069	802-09838	SFT	\$31.000	109.000	\$3,379.00	36.500	\$1,131.50	145.500	\$4,510.50
SIGN, SHEET, WITH LEGEND, 0.080 IN.									
<b>Reason:</b> Balancing Change Order									
				<b>Funding Details</b>					
			Protected Bike Lane	109.000	\$3,379.00	36.500	\$1,131.50	145.500	\$4,510.50
			Rain Gardens	0.000	\$0.00	0.000	\$0.00	0.000	\$0.00
079	805-78485	LFT	\$2.500	500.000	\$1,250.00	25.000	\$62.50	525.000	\$1,312.50
SIGNAL CABLE, CONTROL, COPPER, 5C/14 GA									
<b>Reason:</b> Balancing Change Order									

Line Number	Item ID	Unit	Unit Price	Current		Change		Revised	
				Quantity	Amount	Quantity	Amount	Quantity	Amount

**Funding Details**

Protected Bike Lane	500.000	\$1,250.00	25.000	\$62.50	525.000	\$1,312.50
Rain Gardens	0.000	\$0.00	0.000	\$0.00	0.000	\$0.00

080	805-78490	LFT	\$2.600	800.000	\$2,080.00	-204.000	-\$530.40	596.000	\$1,549.60
-----	-----------	-----	---------	---------	------------	----------	-----------	---------	------------

SIGNAL CABLE, CONTROL, COPPER, 7C/14 GA

**Reason:** Balancing Change Order

**Funding Details**

Protected Bike Lane	800.000	\$2,080.00	-204.000	-\$530.40	596.000	\$1,549.60
Rain Gardens	0.000	\$0.00	0.000	\$0.00	0.000	\$0.00

082	805-78795	LFT	\$36.000	20.000	\$720.00	-0.300	-\$10.80	19.700	\$709.20
-----	-----------	-----	----------	--------	----------	--------	----------	--------	----------

SAW CUT FOR ROADWAY LOOP DETECTOR AND SEALANT

**Reason:** Balancing Change Order

**Funding Details**

Protected Bike Lane	20.000	\$720.00	-0.300	-\$10.80	19.700	\$709.20
Rain Gardens	0.000	\$0.00	0.000	\$0.00	0.000	\$0.00

083	808-02977	EACH	\$146.000	31.000	\$4,526.00	2.000	\$292.00	33.000	\$4,818.00
-----	-----------	------	-----------	--------	------------	-------	----------	--------	------------

PAVEMENT MESSAGE MARKING, THERMOPLASTIC, BIKE SYMBOL

**Reason:** Balancing Change Order



Line Number	Item ID	Unit	Unit Price	Current		Change		Revised	
				Quantity	Amount	Quantity	Amount	Quantity	Amount

**Funding Details**

Protected Bike Lane	31.000	\$4,526.00	2.000	\$292.00	33.000	\$4,818.00
Rain Gardens	0.000	\$0.00	0.000	\$0.00	0.000	\$0.00

084            808-03439    LFT            \$5.950       1,805.000       \$10,739.75       -336.000       -\$1,999.20       1,469.000       \$8,740.55

TRANSVERSE MARKING, THERMOPLASTIC, CROSSWALK LINE, WHITE, 24 IN.

**Reason:** Balancing Change Order

**Funding Details**

Protected Bike Lane	1,805.000	\$10,739.75	-336.000	-\$1,999.20	1,469.000	\$8,740.55
Rain Gardens	0.000	\$0.00	0.000	\$0.00	0.000	\$0.00

088            808-06701    LFT            \$3.000       70.000       \$210.00       -34.000       -\$102.00       36.000       \$108.00

LINE, THERMOPLASTIC, BROKEN, WHITE, 4 IN.

**Reason:** Balancing Change Order

**Funding Details**

Protected Bike Lane	70.000	\$210.00	-34.000	-\$102.00	36.000	\$108.00
Rain Gardens	0.000	\$0.00	0.000	\$0.00	0.000	\$0.00

089            808-06703    LFT            \$0.750       910.000       \$682.50       -455.000       -\$341.25       455.000       \$341.25

LINE, THERMOPLASTIC, SOLID, WHITE, 4 IN.

**Reason:** Balancing Change Order

Line Number	Item ID	Unit	Unit Price	Current		Change		Revised	
				Quantity	Amount	Quantity	Amount	Quantity	Amount

**Funding Details**

Protected Bike Lane	910.000	\$682.50	-455.000	-\$341.25	455.000	\$341.25
Rain Gardens	0.000	\$0.00	0.000	\$0.00	0.000	\$0.00

090	808-10118	EACH	\$13.350	61.000	\$814.35	-11.000	-\$146.85	50.000	\$667.50
-----	-----------	------	----------	--------	----------	---------	-----------	--------	----------

"SHARKS TEETH", THERMOPLASTIC, YIELD LINE, WHITE

**Reason:** Balancing Change Order

**Funding Details**

Protected Bike Lane	61.000	\$814.35	-11.000	-\$146.85	50.000	\$667.50
Rain Gardens	0.000	\$0.00	0.000	\$0.00	0.000	\$0.00

091	808-11493	LFT	\$3.000	635.000	\$1,905.00	49.000	\$147.00	684.000	\$2,052.00
-----	-----------	-----	---------	---------	------------	--------	----------	---------	------------

LINE, THERMOPLASTIC, DOTTED, YELLOW, 4 IN.

**Reason:** Balancing Change Order

**Funding Details**

Protected Bike Lane	635.000	\$1,905.00	49.000	\$147.00	684.000	\$2,052.00
Rain Gardens	0.000	\$0.00	0.000	\$0.00	0.000	\$0.00

092	808-75215	LFT	\$3.000	40.000	\$120.00	244.500	\$733.50	284.500	\$853.50
-----	-----------	-----	---------	--------	----------	---------	----------	---------	----------

LINE, THERMOPLASTIC, SOLID, WHITE, 12 IN.

**Reason:** Balancing Change Order

Line Number	Item ID	Unit	Unit Price	Current		Change		Revised	
				Quantity	Amount	Quantity	Amount	Quantity	Amount

**Funding Details**

Protected Bike Lane	40.000	\$120.00	244.500	\$733.50	284.500	\$853.50
Rain Gardens	0.000	\$0.00	0.000	\$0.00	0.000	\$0.00

093                    808-75240        LFT                    \$3.000            75.000            \$225.00            90.400            \$271.20            165.400            \$496.20

LINE, THERMOPLASTIC, BROKEN, YELLOW, 4 IN.

**Reason:** Balancing Change Order

**Funding Details**

Protected Bike Lane	75.000	\$225.00	90.400	\$271.20	165.400	\$496.20
Rain Gardens	0.000	\$0.00	0.000	\$0.00	0.000	\$0.00

094                    808-75245        LFT                    \$0.800            6,955.000            \$5,564.00            -849.000            -\$679.20            6,106.000            \$4,884.80

LINE, THERMOPLASTIC, SOLID, YELLOW, 4 IN.

**Reason:** Balancing Change Order

**Funding Details**

Protected Bike Lane	6,955.000	\$5,564.00	-849.000	-\$679.20	6,106.000	\$4,884.80
Rain Gardens	0.000	\$0.00	0.000	\$0.00	0.000	\$0.00

095                    808-75260        LFT                    \$3.000            75.000            \$225.00            77.000            \$231.00            152.000            \$456.00

TRANSVERSE MARKING, THERMOPLASTIC, CROSSHATCH LINE, WHITE, 12 IN.

**Reason:** Balancing Change Order



Line Number	Item ID	Unit	Unit Price	Current		Change		Revised	
				Quantity	Amount	Quantity	Amount	Quantity	Amount

Funding Details									
-----------------	--	--	--	--	--	--	--	--	--

Protected Bike Lane	75.000	\$225.00	77.000	\$231.00	152.000	\$456.00
Rain Gardens	0.000	\$0.00	0.000	\$0.00	0.000	\$0.00

096	808-75278	LFT	\$3.050	24.000	\$73.20	-24.000	-\$73.20	0.000	\$0.00
-----	-----------	-----	---------	--------	---------	---------	----------	-------	--------

TRANSVERSE MARKING, THERMOPLASTIC, CROSSHATCH LINE, YELLOW, 12 IN.

Reason: Balancing Change Order

Funding Details									
-----------------	--	--	--	--	--	--	--	--	--

Protected Bike Lane	24.000	\$73.20	-24.000	-\$73.20	0.000	\$0.00
Rain Gardens	0.000	\$0.00	0.000	\$0.00	0.000	\$0.00

097	808-75297	LFT	\$6.000	205.000	\$1,230.00	50.000	\$300.00	255.000	\$1,530.00
-----	-----------	-----	---------	---------	------------	--------	----------	---------	------------

TRANSVERSE MARKING, THERMOPLASTIC, STOP LINE, WHITE, 24 IN.

Reason: Balancing Change Order

Funding Details									
-----------------	--	--	--	--	--	--	--	--	--

Protected Bike Lane	205.000	\$1,230.00	50.000	\$300.00	255.000	\$1,530.00
Rain Gardens	0.000	\$0.00	0.000	\$0.00	0.000	\$0.00

098	808-75320	EACH	\$118.000	36.000	\$4,248.00	-4.000	-\$472.00	32.000	\$3,776.00
-----	-----------	------	-----------	--------	------------	--------	-----------	--------	------------

PAVEMENT MESSAGE MARKING, THERMOPLASTIC LANE INDICATION ARROW

Reason: Balancing Change Order

Line Number	Item ID	Unit	Unit Price	Current		Change		Revised	
				Quantity	Amount	Quantity	Amount	Quantity	Amount

**Funding Details**

Protected Bike Lane	36.000	\$4,248.00	-4.000	-\$472.00	32.000	\$3,776.00
Rain Gardens	0.000	\$0.00	0.000	\$0.00	0.000	\$0.00

099	808-96075	LFT	\$4.000	173.000	\$692.00	-21.000	-\$84.00	152.000	\$608.00
-----	-----------	-----	---------	---------	----------	---------	----------	---------	----------

LINE, THERMOPLASTIC, BROKEN, WHITE, 6 IN.

**Reason:** Balancing Change Order

**Funding Details**

Protected Bike Lane	173.000	\$692.00	-21.000	-\$84.00	152.000	\$608.00
Rain Gardens	0.000	\$0.00	0.000	\$0.00	0.000	\$0.00

0100	808-99199	LFT	\$50.000	370.000	\$18,500.00	-370.000	-\$18,500.00	0.000	\$0.00
------	-----------	-----	----------	---------	-------------	----------	--------------	-------	--------

TRANSVERSE MARKING, PREFORMED PLASTIC, 36" SOLID GREEN

**Reason:** Balancing Change Order

**Funding Details**

Protected Bike Lane	370.000	\$18,500.00	-370.000	-\$18,500.00	0.000	\$0.00
Rain Gardens	0.000	\$0.00	0.000	\$0.00	0.000	\$0.00

0101	808-09968	SFT	\$10.300	1,700.000	\$17,510.00	-1,700.000	-\$17,510.00	0.000	\$0.00
------	-----------	-----	----------	-----------	-------------	------------	--------------	-------	--------

PAVEMENT MARKING, GREEN LANE

**Reason:** Balancing Change Order

Line Number	Item ID	Unit	Unit Price	Current		Change		Revised		
				Quantity	Amount	Quantity	Amount	Quantity	Amount	
				<b>Funding Details</b>						
				Protected Bike Lane	1,700.000	\$17,510.00	-1,700.000	-\$17,510.00	0.000	\$0.00
				Rain Gardens	0.000	\$0.00	0.000	\$0.00	0.000	\$0.00
0102	808-95935	LFT	\$10.000	30.000	\$300.00	-8.000	-\$80.00	22.000	\$220.00	
CURB PAINTING, BLUE										
<b>Reason:</b> Balancing Change Order										
				<b>Funding Details</b>						
				Protected Bike Lane	30.000	\$300.00	-8.000	-\$80.00	22.000	\$220.00
				Rain Gardens	0.000	\$0.00	0.000	\$0.00	0.000	\$0.00
0103	808-95936	LFT	\$10.000	19.000	\$190.00	97.000	\$970.00	116.000	\$1,160.00	
CURB PAINTING, GRAY										
<b>Reason:</b> Balancing Change Order										
				<b>Funding Details</b>						
				Protected Bike Lane	19.000	\$190.00	97.000	\$970.00	116.000	\$1,160.00
				Rain Gardens	0.000	\$0.00	0.000	\$0.00	0.000	\$0.00
0104	808-95933	LFT	\$12.000	185.000	\$2,220.00	2.000	\$24.00	187.000	\$2,244.00	
CURB PAINTING, YELLOW										
<b>Reason:</b> Balancing Change Order										



Line Number	Item ID	Unit	Unit Price	Current		Change		Revised		
				Quantity	Amount	Quantity	Amount	Quantity	Amount	
				<b>Funding Details</b>						
				Protected Bike Lane	185.000	\$2,220.00	2.000	\$24.00	187.000	\$2,244.00
				Rain Gardens	0.000	\$0.00	0.000	\$0.00	0.000	\$0.00
0105	808-12274	LFT	\$9.000	30.000	\$270.00	18.000	\$162.00	48.000	\$432.00	
TRANSVERSE MARKING, THERMOPLASTIC, PARKING "T", 3'X3', 4"										
<b>Reason:</b> Balancing Change Order										
				<b>Funding Details</b>						
				Protected Bike Lane	30.000	\$270.00	18.000	\$162.00	48.000	\$432.00
				Rain Gardens	0.000	\$0.00	0.000	\$0.00	0.000	\$0.00
0106	802-04089	EACH	\$75.000	6.000	\$450.00	32.000	\$2,400.00	38.000	\$2,850.00	
SIGN, REMOVE										
<b>Reason:</b> Balancing Change Order										
				<b>Funding Details</b>						
				Protected Bike Lane	6.000	\$450.00	32.000	\$2,400.00	38.000	\$2,850.00
				Rain Gardens	0.000	\$0.00	0.000	\$0.00	0.000	\$0.00
0107	808-06716	LFT	\$3.000	270.000	\$810.00	-190.000	-\$570.00	80.000	\$240.00	
LINE, REMOVE										
<b>Reason:</b> Balancing Change Order										

Line Number	Item ID	Unit	Unit Price	Current		Change		Revised	
				Quantity	Amount	Quantity	Amount	Quantity	Amount
				<b>Funding Details</b>					
			Protected Bike Lane	270.000	\$810.00	-190.000	-\$570.00	80.000	\$240.00
			Rain Gardens	0.000	\$0.00	0.000	\$0.00	0.000	\$0.00
0108	605-06125	LFT	\$115.000	723.000	\$83,145.00	-151.500	-\$17,422.50	571.500	\$65,722.50
CURB, MODIFIED STRAIGHT (RAIN GARDENS)									
<b>Reason:</b> Balancing Change Order									
				<b>Funding Details</b>					
			Protected Bike Lane	0.000	\$0.00	0.000	\$0.00	0.000	\$0.00
			Rain Gardens	723.000	\$83,145.00	-151.500	-\$17,422.50	571.500	\$65,722.50
0120	604-06070	SYS	\$85.620	103.820	\$8,889.07	23.970	\$2,052.31	127.790	\$10,941.38
SIDEWALK, CONCRETE									
<b>Reason:</b> Balancing Change Order									
				<b>Funding Details</b>					
			Protected Bike Lane	103.820	\$8,889.07	23.970	\$2,052.31	127.790	\$10,941.38
			Rain Gardens	0.000	\$0.00	0.000	\$0.00	0.000	\$0.00
77 items	Totals				\$1,836,296.85		-\$192,095.69		\$1,644,201.16



# Funding Summary

Fund Package	Original Amount	Authorized Amount	Pending Change	Revised Amount
Protected Bike Lane	\$2,362,877.67	\$2,452,673.32	-\$181,427.53	\$2,271,245.79
Rain Gardens	\$209,577.33	\$209,577.33	-\$10,668.16	\$198,909.17
2 fund packages	\$2,572,455.00	\$2,662,250.65	-\$192,095.69	\$2,470,154.96

Not valid until signed by the Engineer, Contractor, and Board of Public Works.



Engineer

Brent Foster

Digitally signed by Brent Foster  
 DN: C=US,  
 E=brent.foster@milestonelp.com,  
 O=Milestone, OU=Milestone,  
 CN=Brent Foster  
 Date: 2023.02.17 13:55:32-05'00'

Contractor

Board of Public Works

City Engineer

Title

General Superintendent

Title

Title

2/22/2023

Date

2-17-23

Date

Date



# Board of Public Works

## Staff Report

---

**Project/Event:** Approve Change Orders #1 and #2 for the 17<sup>th</sup> Street Multi-Use Path EAST Project

**Petitioner/Representative:** Engineering Department

**Staff Representative:** Roy Aten, Senior Project Manager

**Date:** 02/28/2022

---

**Report:**

This project was awarded to Milestone Contractors on April 12<sup>th</sup>, 2022 in the amount of \$1,192,901.58. This project installed a multi-use path on the north side of 17th Street from Walnut Street to Grant Street. Change Order #1 will add \$25,453.00 for additional work in the Red Restaurant parking area. Change Order #2 will add \$2,054.28 for additional curb ramp work at the intersection of 17th and Grant. Pending approval of these change orders and funding approval from the Redevelopment Commission, the final contract price will be \$1,220,408.86.

## City of Bloomington Contract and Purchase Justification Form

Vendor: Milestone Contractors, LP

Contract Amount: \$1,192,901.58

This form should be completed and attached to the contract documents and forwarded to the Legal Department Attorney assigned to your Department. Contracts will not be approved by the Controller if a completed form is not included with the contract documents.

### PURCHASE INFORMATION

1. Check the box beside the procurement method used to initiate this procurement: (Attach a quote or bid tabulation if applicable)

<input type="checkbox"/> Request for Quote (RFQ)	<input type="checkbox"/> Request for Proposal (RFP)	<input type="checkbox"/> Sole Source	<input checked="" type="checkbox"/> Not Applicable (NA)
<input type="checkbox"/> Invitation to Bid (ITB)	<input type="checkbox"/> Request for Qualifications (RFQu)	<input type="checkbox"/> Emergency Purchase	

2. List the results of procurement process. Give further explanation where requested.

	Yes	No		Yes	No
# of Submittals: 1			Was the lowest cost selected? (If no, please state below why it was not.)	<input checked="" type="checkbox"/>	<input type="checkbox"/>
Met city requirements?	<input checked="" type="checkbox"/>	<input type="checkbox"/>	Contract awarded April 12th, 2022 through the Board of Public Works		
Met item or need requirements?	<input checked="" type="checkbox"/>	<input type="checkbox"/>			
Was an evaluation team used?	<input type="checkbox"/>	<input checked="" type="checkbox"/>			
Was scoring grid used?	<input type="checkbox"/>	<input checked="" type="checkbox"/>			
Were vendor presentations requested?	<input type="checkbox"/>	<input checked="" type="checkbox"/>			

3. State why this vendor was selected to receive the award and contract:

Contract was approved by the Board of Public Works on April 12th, 2022. These Change Orders are being presented in compliance with the contract documents for the 17th Street Multi-Use path EAST Project.

Award	\$1,1192,901.58
Previous change Orders	\$0.00
Change Order #1	\$25,453.00
Change Order #2	\$2,054.28
Final contract	\$1,220,408.86

\_\_\_\_\_  
Roy Aten

\_\_\_\_\_  
Senior Project Manager

\_\_\_\_\_  
Engineering

Print/Type Name

Print/Type Title

Department



# City of Bloomington, Indiana

## Change Order Details

### 17th Street Multi-Use Path EAST

---

<b>Description</b>	Installation of a multi-use path, curb and ramp replacement, installation of storm sewer, and milling and resurfacing East 17th Street from North Walnut Street to North Grant Street.
<b>Prime Contractor</b>	Milestone Contractors, L.P 3301 S. 460 E. Laffayette, IN
<b>Change Order</b>	1
<b>Status</b>	Pending
<b>Date Created</b>	12/12/2022
<b>Type</b>	Errors and Omissions, Non-recoverable
<b>Summary</b>	Red Restaurant Driveway Modifications
<b>Change Order Description</b>	During construction it was discovered that the cross slope for the parking area in the Red Restaurant exceeded a reasonable slope. The engineer redesigned the parking area and drive entrance. The contractor had to demo a portion of the finished work and reconstruct the area. This work was done outside the time limits for the project, so no additional days are to be added.
<b>Awarded Project Amount</b>	\$1,192,901.58
<b>Authorized Project Amount</b>	\$1,192,901.58
<b>Change Order Amount</b>	\$25,453.00
<b>Revised Project Amount</b>	\$1,218,354.58

# New Items

Line Number	Item ID	Unit	Quantity	Unit Price	Extension
<b>Section: 1 - Description</b>					
0110	402-05499	LS	1.000	\$25,453.000	\$25,453.00
□MA, RECONSTRUCT PARKING AREA					
<b>Reason:</b> Reconstruction of Red Restaurant parking lot.					
1 item					Total: \$25,453.00

# Attachments

Document	Name	Description	Submission Date
□ang_Property_Change_Order_17th_Street_City_of_Bloomington_Updated.pdf	□ang Property Change Order 17th Street City of Bloomington_Updated.pdf	Milestone Breakdown.	12/15/2022 08:20 AM EST
1 attachment			

Not valid until signed by the Engineer, Contractor, and Owner

\_\_\_\_\_  
Engineer

\_\_\_\_\_  
Contractor

\_\_\_\_\_  
Board of Public Works

\_\_\_\_\_  
Title

General Superintendent

\_\_\_\_\_  
Title

\_\_\_\_\_  
Title

\_\_\_\_\_  
Date

\_\_\_\_\_  
12/15/22

\_\_\_\_\_  
Date

\_\_\_\_\_  
Date



# City of Bloomington, Indiana

## Change Order Details

### 17th Street Multi-Use Path EAST

---

<b>Description</b>	Installation of a multi-use path, curb and ramp replacement, installation of storm sewer, and milling and resurfacing East 17th Street from North Walnut Street to North Grant Street.
<b>Prime Contractor</b>	Milestone Contractors, L.P 3301 S. 460 E. Laffayette, IN
<b>Change Order</b>	2
<b>Status</b>	Pending
<b>Date Created</b>	12/12/2022
<b>Type</b>	Scope Changes
<b>Summary</b>	Wreck / Replace Curb & Fill Between Wall and Curb with Concrete.
<b>Change Order Description</b>	After construction it was determined that the curb work at the intersection of 17th and Grant needed to be reworked in order to improve safety for vehicles traveling on Grant. Milestone removed the previously installed curb and reinstalled a modified curb. This work was done outside of the original contract time and no additional days are being added.
<b>Awarded Project Amount</b>	\$1,192,901.58
<b>Authorized Project Amount</b>	\$1,192,901.58
<b>Change Order Amount</b>	\$2,054.28
<b>Revised Project Amount</b>	\$1,194,955.86

**New Items**

Line Number	Item ID	Unit	Quantity	Unit Price	Extension
<b>Section: 1 - Description</b>					
0120	109-04299	DOL	1.000	\$2,054.280	\$2,054.28
FORCE ACCOUNT WORK: 17th and Grant Curb Work					
<b>Reason:</b> Rework SE corner of 17th and Grant.					
1 item					Total: \$2,054.28

Not valid until signed by the Engineer, Contractor, and Owner

_____	_____	_____
Engineer	Contractor	Board of Public Works
_____	<b>General Superintendent</b>	_____
Title	Title	Title
_____	<b>12-16-22</b>	_____
Date	Date	Date





# Board of Public Works

## Staff Report

---

**Project/Event:** Approve B-Line Tree Clearing Contract to Bluestone Tree  
**Petitioner/Representative:** Engineering Department  
**Staff Representative:** Roy Aten, Senior Project Manager  
**Date:** 02/28/2022

---

### Report:

This project will remove the necessary trees along the B-Line Extension Projects corridor. Bids were opened at the February 27<sup>th</sup>, 2023 Board of Public Works work session. Four bidders submitted bids.

<b>Bidder</b>	<b>Bid amount</b>
Bluestone Tree, Inc.	\$48,764.20
J.R. Ellington Tree Experts	\$68,295.00
Monroe LLC	\$53,250.00
Crider & Crider, Inc.	\$192,450.00

With the lowest responsive and responsible bidder being Bluestone Tree, Inc.

## City of Bloomington Contract and Purchase Justification Form

Vendor: Bluestone Tree, Inc

Contract Amount: \$48,764.36

This form should be completed and attached to the contract documents and forwarded to the Legal Department Attorney assigned to your Department. Contracts will not be approved by the Controller if a completed form is not included with the contract documents.

### PURCHASE INFORMATION

1. Check the box beside the procurement method used to initiate this procurement: (Attach a quote or bid tabulation if applicable)

<input type="checkbox"/> Request for Quote (RFQ)	<input type="checkbox"/> Request for Proposal (RFP)	<input type="checkbox"/> Sole Source	<input type="checkbox"/> Not Applicable (NA)
<input checked="" type="checkbox"/> Invitation to Bid (ITB)	<input type="checkbox"/> Request for Qualifications (RFQu)	<input type="checkbox"/> Emergency Purchase	

2. List the results of procurement process. Give further explanation where requested.

# of Submittals: 4

	Yes	No
Met city requirements?	<input checked="" type="checkbox"/>	<input type="checkbox"/>
Met item or need requirements?	<input checked="" type="checkbox"/>	<input type="checkbox"/>
Was an evaluation team used?	<input type="checkbox"/>	<input checked="" type="checkbox"/>
Was scoring grid used?	<input type="checkbox"/>	<input checked="" type="checkbox"/>
Were vendor presentations requested?	<input type="checkbox"/>	<input checked="" type="checkbox"/>

Was the lowest cost selected? (If no, please state below why it was not.)

Yes  No

Bids were solicited in compliance with IAC 36-1-12 and the City of Bloomington's Financial Policies Manual (Updated January 2018)

3. State why this vendor was selected to receive the award and contract:

Contract will be awarded at the February 28th, 2023 Board of Public Works to the lowest responsive and responsible bidder.

Roy Aten

---

Print/Type Name

Senior Project Manager

---

Print/Type Title

Engineering

---

Department

# AGREEMENT

BETWEEN

CITY OF BLOOMINGTON

ENGINEERING DEPARTMENT

AND

CONTRACTOR

FOR

**B-Line Extension Tree Clearing**

**THIS AGREEMENT**, executed by and between the City of Bloomington, Indiana, Engineering Department through the Board of Public Works (hereinafter CITY), and Bluestone Tree, Inc. (hereinafter CONTRACTOR);

**WITNESSETH THAT:**

WHEREAS, CITY desires to retain CONTRACTOR'S services for **removal of selected trees along the proposed B-Line Extension Project**, (more particularly described in Attachment A, "Scope of Work"; and

WHEREAS, CONTRACTOR is capable of performing work as per his/her Bid on the Bid Summary sheet; and

WHEREAS, in accordance with Indiana Code 5-16-13 *et seq.*, incorporated herein by reference, Contractor is a Tier 1 or General Contractor for this project; and

WHEREAS, CONTRACTOR was determined to be the lowest responsible and responsive Bidder for said project.

NOW, THEREFORE, in consideration of the mutual promises hereinafter enumerated, the parties agree as follows:

**ARTICLE 1. TERM**

**1.01** This Agreement shall be in effect upon execution of this Agreement by all parties. In accordance with Indiana Code 5-16-13 *et seq.*, incorporated herein by reference, Contractor is a Tier 1 contractor or general contractor for this project.

**ARTICLE 2. SERVICES**

**2.01** Contractor shall complete all Work as specified or indicated in the Contract Documents. The Work is generally described in Attachment A, "Scope of Work".

**2.02** All work required under this Agreement shall be substantially completed by the CONTRACTOR within sixty (60) calendar days from the date of the Notice to Proceed, unless the parties mutually agree to a later completion date. Substantial Completion shall mean that all work is sufficiently completed in accordance with the plans and specifications, as modified by any approved change orders, so that it can be used for its intended purpose.

**2.03** It is hereby understood by both parties that time is of the essence in this Agreement. Failure of CONTRACTOR to complete all work as herein provided will result in monetary damages to CITY. It is hereby agreed that CITY will be damaged for every day the work has not been performed in the manner herein provided and that the measure of those damages shall be determined by reference Section 13.00 of the General Conditions for Each Day of Overrun in Contract Time. CONTRACTOR agrees to pay CITY said damages or, in the alternative, CITY, at its sole discretion, may withhold monies otherwise due CONTRACTOR. It is expressly understood by the parties hereto that these damages relate to the time of performance and do not limit CITY's other remedies under this Agreement, or as provided by applicable law, for other damages.

**2.04** CONTRACTOR agrees that no charges or claims for damages shall be made by him or her for any delays or hindrances, from any cause whatsoever during the progress of any portion of the services specified in the Agreement. Such delays or hindrances, if any, may be compensated for by an extension of time for a reasonable period as may be mutually agreed upon between the parties, it being understood, however, that permitting CONTRACTOR to proceed to complete any service, or any part of the services / project, after the date to which the time of completion may have been extended, shall in no way operate as a waiver on the part of CITY of any of its rights herein.

### **ARTICLE 3. COMPENSATION**

**3.01** CONTRACTOR shall provide services as specified in Attachment A, "Scope of Work", attached hereto and incorporated into this Agreement.

**3.02** Owner shall pay Contractor for completion of the Work in accordance with the Contract Documents, subject to adjustment under the Contract, at the unit prices stated in Contractor's Bid, attached hereto as Attachment 'E'. CITY may withhold payment, in whole or in part, to the extent necessary to protect itself from a loss on account of any of the following:

Defective work.

Evidence indicating the probable filing of claims by other parties against CONTRACTOR which may adversely affect CITY.

Failure of CONTRACTOR to make payments due to subcontractors, material suppliers or employees.

Damage to CITY or a third party.

**3.03** The submission of any request for payment shall be deemed a waiver and release by CONTRACTOR of all liens and claims with respect to the work and period to which such payment request pertains except as specifically reserved and noted on such request.

**3.04** CONTRACTOR shall maintain proper account records for the scope of all services of this Agreement and provide an accounting for all charges and expenditures as may be necessary for audit purposes. All such records shall be subject to inspection and examination by CITY's representatives at reasonable business hours.

**3.05** For projects utilizing federal funding the CONTRACTOR shall submit time sheets (WH-347) for his or her own and all subcontracted employees, to City Engineer or his or her representative for approval and review, including review for compliance with Davis Bacon requirements, if federal funds are used.

**3.06** **Engineer** The City Engineer shall act as the CITY's representative and assume all duties and responsibilities and have all the rights and authority assigned to the Engineer in the Contract Documents in connection with completion of the Work in accordance with the Contract Documents.

### **ARTICLE 4. RETAINAGE**

For contracts in excess of \$100,000 and for which Contractor requested Progressive Payments on its Bid Form, the Owner requires that retainage be held set out below.

**4.01** **Escrow Agent** The retainage amount withheld shall be placed in an escrow account. First Financial Bank, Bloomington, Indiana, shall serve as the escrow agent.

**4.02** **Retainage Amount** The escrow agent, Owner and Contractor shall enter into a written escrow agreement. Under that agreement, the Owner shall withhold five percent (5%) of the dollar value of all work satisfactorily completed until the Contract work is complete. The escrow agent shall invest all escrowed principal in obligations selected by the escrow agent. The escrow agent shall be compensated for the agent's services by a reasonable fee, agreed upon by the parties, that is comparable with fees charged for the handling of escrow accounts of similar size and duration. The fee shall be paid from the escrow income. The escrow agent's fee may be determined by specifying an amount of interest the escrow agent will pay on the escrowed amount, with any additional earned interest serving as the escrow agent's fee. The escrow agreement may include other terms and conditions as deemed necessary by the parties. However, if Contractor intends to receive a Single Lump Sum payment upon acceptance of this project, retainage will not be required and an Escrow Agreement will not be required.

**4.03** **Payment of Escrow Amount** The escrow agent shall hold the escrowed principal and income until receipt of the notice from the Owner and Contractor that the Contract work has been substantially completed to the reasonable satisfaction of the Owner, at which time the Owner shall pay to the Contractor the balance to be paid under this Contract and execute such documents as are necessary to authorize the escrow agent to pay to the Contractor the funds in the escrow account, including both specifying the part of the escrowed principal to be released from the escrow and the person to whom that portion is to be released. After receipt of the notice, the escrow agent shall remit the designated part of the escrowed principal and the escrowed income, minus the escrow agent's fees, to the person specified in the notice. However, nothing in this section shall prohibit Owner from requiring the escrow agent to withhold amounts necessary to complete minor items of the Contract, following substantial completion of the Contract in accordance with the provisions of paragraph 4.04.

**4.04** **Withholding Funds for Completion of Contract** If, upon substantial completion of the Contract, there still remains minor Contract work that needs to be completed, or minor Contract work that needs to be performed to the satisfaction of the Owner, Owner may direct the escrow agent to retain in the escrow account, and withhold from payment to the Contractor, an amount equal to two hundred percent (200%) of the value of said work. The value of said work shall be determined by the architect/engineer. The escrow agent shall release the funds withheld under this section after receipt of notice from the Owner that all work on the Contract has been satisfactorily completed. In the event that said work is not completed by the Contractor, but by Owner or another party under contract with the Owner, said funds shall be released to the Owner.

## **ARTICLE 5. GENERAL PROVISIONS**

**5.01** CONTRACTOR agrees to indemnify and hold harmless CITY and its officers, agents, officials and employees for any and all claims, actions, causes of action, judgments and liens arising out of any negligent act or omission by CONTRACTOR or any of its officers, agents, officials, employees, or subcontractors or any defect in materials or workmanship of any supply, materials, mechanism or other product or service which it or any of its officers, agents, officials, employees, or subcontractors has supplied to CITY or has used in connection with this Agreement and regardless of whether or not it is caused in part by a party indemnified herein under. Such indemnity shall include attorney's fees and all costs and other expenses arising there from or incurred in connection therewith and shall not be limited by reason of the enumeration of any insurance coverage required herein.

CONTRACTOR shall indemnify and hold harmless CITY and its officers, agents, officials and employees for any and all damages, actions, costs, (including, but not limited to, attorney's fees, court costs and costs of investigation) judgments and claims by anyone for damage to property, injury or death to persons resulting from the collapse or failure of any trenches, ditches or other excavations constructed under or associated with this contract.

### **5.02 Abandonment, Default and Termination**

**5.02.01** CITY shall have the right to abandon the work contracted for in this Agreement without penalty. If CITY abandons the work described herein, CONTRACTOR shall deliver to CITY all surveys, notes, drawings, specifications and estimates completed or partially completed and these shall become the property of CITY. The earned value of the work performed shall be based upon an estimate of the proportion between the work performed by CONTRACTOR under this Agreement and the work which CONTRACTOR was obligated to perform under this Agreement. This proportion shall be mutually agreed upon by CITY and CONTRACTOR. The payment made to CONTRACTOR shall be paid as a final payment in full settlement of his or her services hereunder.

**5.02.02** If CONTRACTOR defaults or fails to fulfill in a timely and proper manner the obligations pursuant to this Agreement, CITY may, after seven (7) days' written notice has been delivered to CONTRACTOR, and without prejudice to any other remedy it may have, make good such deficiencies and may deduct the cost thereof from the payment then or thereafter due to CONTRACTOR. In the alternative, CITY, at its option, may terminate this Agreement and take possession of the site and of all materials, equipment, tools and construction equipment and machinery thereon owned by CONTRACTOR, and may finish the project by whatever method it may deem expedient, and if the such action exceeds the unpaid balance of the sum amount, CONTRACTOR or his or her surety, shall pay the difference to CITY.

**5.02.03 Default:** If CONTRACTOR breaches this Agreement or fails to perform the work in an acceptable manner, he or she shall be considered in default. Any one or more of the following will be considered a default:

Failure to begin the work under this Agreement within the time specified.

Failure to perform the work with sufficient supervision, workmen, equipment and materials to insure prompt completion of said work within the time limits allowed.

Unsuitable performance of the work as determined by CITY ENGINEER or his or her representative.

Neglecting or refusing to remove defective materials or failure to perform anew such work as shall have been rejected.

Discontinuing the prosecution of the work or any part of it.

Inability to finance the work adequately.

If, for any other reason, CONTRACTOR breaches this Agreement or fails to carry on the work in an acceptable manner.

**5.02.04** CITY shall send CONTRACTOR a written notice of default. If CONTRACTOR, or his or her Surety, within a period of ten (10) days after such notice, fails to remedy the default, then CITY shall have full power and authority, without violation of the Contract, to take the prosecution of the work out of the hands of said CONTRACTOR, to appropriate or use any or all materials and equipment on the ground as may be suitable and acceptable, and may, at its option, turn the work over to the Surety, or enter into an agreement with another Contractor for the completion of the Agreement according to the terms and provisions thereof, or CITY may use such other methods as, in its opinion, shall be required for the completion of said Contract in an acceptable manner.

**5.02.05** All cost of completing the work under the Contract shall be deducted from the monies due or which may become due to said CONTRACTOR. In case the expenses so incurred by CITY shall be less than the sum which would have been payable under the Contract if it had been completed by said CONTRACTOR, CONTRACTOR shall be entitled to receive the difference. However, in case such expense shall exceed the sum which would have been payable under the Contract, CONTRACTOR and his or her Surety will be liable and shall pay to CITY the amount of said excess. By taking over the prosecution of the work, CITY does not forfeit the right to recover damages from CONTRACTOR or his or her Surety for his or her failure to complete the work in the time specified.

**5.02.06** Notwithstanding any other provision of this Agreement, if funds for the continued fulfillment of the Agreement by CITY are at any time not forthcoming or are insufficient, through failure of any entity to appropriate the funds or otherwise, then CITY shall have the right to terminate this Agreement without penalty by giving prior written notice documenting the lack of funding in which instance, unless otherwise agreed to by the parties, this Agreement shall terminate and become null and void.

**5.02.07** CITY agrees that it will make its best effort to obtain sufficient funds, including but not limited to, including in its budget for each fiscal period during the term hereof a request for sufficient funds to meet its obligations hereunder in full.

**5.03 Successors and Assigns**

**5.03.01** Both parties agree that for the purpose of this Agreement, CONTRACTOR shall be an Independent Contractor and not an employee of CITY.

**5.03.02** No portion of this Agreement shall be sublet, assigned, transferred or otherwise disposed of by CONTRACTOR except with the written consent of CITY being first obtained. Consent to sublet, assign, transfer, or otherwise dispose of any portion of this Agreement shall not be construed to relieve CONTRACTOR of any responsibility of the fulfillment of this Agreement.

**5.04 Extent of Agreement: Integration**

**5.04.01** This Agreement consists of the following parts, each of which is as fully a part of this Agreement as if set out herein:

1. This Agreement and its Attachments.
2. All Written Amendments and other documents amending, modifying, or supplementing the Contract Documents which may be delivered or issued after the Effective Date of the Agreement and are not attached hereto.
3. All Addenda to the Bid Documents.
4. The Invitation to Bidders.
5. The Instructions to Bidders.
6. The Special Conditions.
7. All plans as provided for the work that is to be completed.
8. The Supplementary Conditions.
9. The General Conditions.
10. The Specifications.
11. The current Indiana Department of Transportation Standard Specifications and the latest addenda.
12. CONTRACTOR'S submittals.
13. The Performance Bond and the Payment Bond.
14. The Escrow Agreement.
15. Request for Taxpayer Identification number and certification: Substitute W-9.

**5.04.02** In resolving conflicts, errors, discrepancies and disputes concerning the Scope of Work to be performed by CONTRACTOR, and other rights and obligations of CITY and CONTRACTOR, the document expressing the greater quantity, quality or other scope of work in question, or imposing the greater obligation upon CONTRACTOR and affording the greater right or remedy to CITY shall govern; otherwise the documents shall be given precedence in the order as enumerated above.

**5.05 Insurance**

**5.05.01**

CONTRACTOR shall, as a prerequisite to this Agreement, purchase and thereafter maintain such insurance as will protect him or her from the claims set forth below which may arise out of or result from CONTRACTOR'S operations under this Agreement, whether such operations be by CONTRACTOR or by any SUBCONTRACTORS or by anyone directly or indirectly employed by any of them, or by anyone for whose acts any of them may be liable:

<u>Coverage</u>	<u>Limits</u>
A. Worker's Compensation & Disability	Statutory Requirements
B. Employer's Liability Bodily Injury by Accident	\$100,000 each accident
Bodily Injury by Disease	\$500,000 policy limit
Bodily Injury by Disease	\$100,000 each employee
C. Commercial General Liability (Occurrence Basis)	\$1,000,000 per occurrence
Bodily Injury, personal injury, property damage, contractual liability, products-completed operations,	and \$2,000,000 in the

General Aggregate Limit (other than Products/Completed Operations)	aggregate
Products/Completed Operation	\$1,000,000
Personal & Advertising Injury Limit	\$1,000,000
Each Occurrence Limit	\$1,000,000
Fire Damage (any one fire)	\$50,000
D.    Comprehensive Auto Liability (single limit, owned, hired and non-owned)	\$1,000,000 each accident
Bodily injury and property damage	
E.    Umbrella Excess Liability	\$5,000,000 each occurrence and aggregate
The Deductible on the Umbrella Liability shall not be more than	\$10,000

**5.05.02** CONTRACTOR'S comprehensive general liability insurance shall also provide coverage for the following:

Premises and operations;

Contractual liability insurance as applicable to any hold-harmless agreements;

Completed operations and products; which also must be maintained for a minimum period of two (2) years after final payment and CONTRACTOR shall continue to provide evidence of such coverage to CITY on an annual basis during the aforementioned period;

Broad form property damage - including completed operations;

Fellow employee claims under Personal Injury; and

Independent Contractors.

**5.05.03** With the prior written approval of CITY, CONTRACTOR may substitute different types or amounts of coverage for those specified as long as the total amount of required protection is not reduced.

**5.05.04** Certificates of Insurance showing such coverage then in force (but not less than the amount shown above) shall be on file with CITY prior to commencement of work. These Certificates shall contain a provision that coverage afforded under the policies will not be canceled or non-renewed until at least sixty (60) days' prior written notice has been received by CITY. The CITY shall be named as an additional insured on the Commercial General Liability, Automobile Liability, and Umbrella Excess Liability policies. The CONTRACTOR shall agree to a waiver of subrogation on its Worker's Compensation policy.

**5.06** **Necessary Documentation** CONTRACTOR certifies that it will furnish CITY any and all documentation, certification, authorization, license, permit or registration required by the laws or rules and regulations of the City of Bloomington, the State of Indiana and the United States. CONTRACTOR further certifies that it is now and will maintain in good standing with such governmental agencies and that it will keep its license, permit registration, authorization or certification in force during the term of this Agreement.

**5.07** **Applicable Laws** CONTRACTOR agrees to comply with all federal, state, and local laws, rules and regulations applicable to CONTRACTOR in performing work pursuant to this Agreement, including, but not limited to, discrimination in employment, prevailing wage laws, conflicts of interest, public notice, accounting records and requirements. CONTRACTOR shall comply with City of Bloomington Ordinance 2.21.020 and all other federal, state and local laws and regulations governing non-discrimination, including but not limited to employment. This Agreement shall be governed by the laws of the United States, and the State of Indiana, and by all Municipal Ordinances and Codes of the City of Bloomington. Venue of any disputes arising under this Agreement shall be in the Monroe Circuit Court, Monroe County, Indiana.

**5.08** **Non-Discrimination**

5.08.01 CONTRACTOR and subcontractors shall not discriminate against any employee or applicant for employment, to be employed in the performance of this Agreement, with respect to hire, tenure, terms, training, conditions or privileges of employment, because of race, sex, color, religion, national origin, ancestry, disability, sexual orientation, gender identity, veteran status or housing status. Breach of this covenant may be regarded as a material breach of the Agreement.



5.08.02 CONTRACTOR certifies for itself and all its subcontractors compliance with existing laws of the City of Bloomington, the State of Indiana and the United States regarding:

Prohibition of discrimination in employment practices on the basis of race, sex, color, religion, national origin, ancestry, disability, sexual orientation, gender identity, veteran status, housing status, or any other legally protected classification;

The utilization of Minority and Women Business Enterprises. CONTRACTOR further certifies that it:

- a. Has formulated its own Affirmative Action plan for the recruitment, training and employment of minorities and women, including goals and timetable; which has been approved by the City's Contract Compliance Officer.
- b. Encourages the use of small business, minority-owned business and women-owned business in its operations.

CONTRACTOR understands that the City of Bloomington prohibits its employees from engaging in harassment or discrimination of any kind, including harassing or discriminating against independent contractors doing work for the City. If CONTRACTOR believes that a City employee engaged in such conduct towards CONTRACTOR and/or any of its employees, CONTRACTOR or its employees may file a complaint with the City department head in charge of the CONTRACTOR'S work and/or with the City human resources department or the Bloomington Human Rights Commission. The City takes all complaints of harassment and discrimination seriously and will take appropriate disciplinary action if it finds that any City employee engaged in such prohibited conduct.

**5.08.03 FURTHER, PURSUANT TO INDIANA CODE 5-16-6-1, CONTRACTOR AGREES:**

- A) That in the hiring of employees for the performance of work under this Agreement or any sub agreement hereunder, no contractor, or subcontractor, nor any person acting on behalf of such CONTRACTOR or subcontractor, shall by reason of race, sex, color, religion, national origin, ancestry, or any other legally protected classification, discriminate against any citizen of the State of Indiana who is qualified and available to perform the work to which the employment relates.
- B) That no contractor, subcontractor, or any person on their behalf, shall, in any manner, discriminate against or intimidate any employee hired for performance of work under this Agreement on account of race, religion, color, sex, national origin, ancestry, or any other legally protected classification.
- C) That there may be deducted from the amount payable to CONTRACTOR, by CITY, under this Agreement, penalty of Five Dollars (\$5.00) for each person for each calendar day during which such person was discriminated against or intimidated in violation of the provisions of this Agreement. Any such person discriminated against retains the right to file a discrimination complaint with the appropriate civil rights agency or court.
- D) That this Agreement may be canceled or terminated by CITY and all money due or to become hereunder may be forfeited, for a second or any subsequent violations of the terms or conditions under this section of the Agreement.

**5.09 Workmanship and Quality of Materials**

**5.09.01** CONTRACTOR shall guarantee the work for a period of one (1) year from the date of substantial completion. Failure of any portion of the work within one (1) year due to improper construction, materials of construction, or design may result in a refund to CITY of the purchase price of that portion which failed or may result in the forfeiture of CONTRACTOR'S Performance Bond.

**5.09.02 OR EQUAL:** Wherever in any of the Agreement Documents an article, material or equipment is defined by describing a proprietary product, or by using the name of a manufacturer or vender, the term "Or Equal" or the term "The Equivalent" if not inserted, shall be implied, and it is done for the express purpose of establishing a basis of durability and efficiency and not for the purpose of limiting completion. Whenever material or equipment is submitted for approval as being equal to that specified, the submittal shall include sufficient information and data to demonstrate that the material or equipment conforms to the Contract requirements. The decision as to whether or not such material or equipment is equal to that specified shall be made by the ENGINEER. The approval by the ENGINEER of alternate material or equipment as being equivalent to that specified, shall not in any way relieve CONTRACTOR of responsibility for failure of the material or equipment due to faulty design, material, or workmanship, to perform the function required by the Contract Documents. Specifications as determined by other entities within the City of Bloomington such as City Utilities shall only be substituted or changed by their approval which shall be submitted in writing to the ENGINEER.

**5.09.03** CITY shall be the sole judge of the sufficiency of workmanship and quality of materials. Disputes shall be resolved by the City Engineer and are not subject to arbitration.

**5.10 Safety.** CONTRACTOR shall be responsible for the safety of employees at all times and shall provide all equipment necessary to insure their safety. CONTRACTOR shall ensure the enforcement of all applicable safety rules, regulations, ordinances and laws, whether federal, state or local. Contractor's Superintendent of Safety shall make daily inspections upon the arrival and leaving of the site at the close of each workday.

**5.10.01** CONTRACTOR is required to comply with IOSHA regulations 29 C.F.R 1926, Subpart P, Excavations for all trenches of at least five (5) feet in depth. All cost for trench safety systems shall be the responsibility of the CONTRACTOR and included in the cost of the principal work with which the safety systems are associated. CONTRACTOR shall sign an affidavit, attached as Attachment B, affirming that CONTRACTOR shall maintain compliance with IOSHA requirements for excavations of at least five (5) in depth.

**5.11 Amendments/Changes**

**5.11.01** Except as provided in Paragraph 5.11.02, this Agreement may be amended only by written instrument signed by both CITY and CONTRACTOR.

**5.11.02** Without invalidating the Agreement and without notice to any surety, CITY may, at any time or from time to time, order, in writing, additions, deletions, or revisions in the work. Upon receipt of any such document, CONTRACTOR shall promptly proceed with the work involved, which will be performed under the applicable conditions of the Agreement Documents.

**5.11.03** If CONTRACTOR believes that any direction of CITY under paragraph 5.11.02, or any other event or condition, will result in an increase in the Contract time or price, he or she shall file written notice with CITY no later than twenty (20) calendar days after the occurrence of the event giving rise to the claim and stating the general nature of the claim with supporting data. No claim for any adjustment of the Contract time or price will be valid if not submitted in accordance with this Paragraph.

**5.11.04** CONTRACTOR shall carry on the work and adhere to the progress schedule during all disputes or disagreements with CITY. No work shall be delayed or postponed pending resolution of any dispute or disagreement except as CONTRACTOR and CITY may otherwise agree in writing.

**5.12 Performance Bond and Payment Bond**

**5.12.01** For contracts in excess of \$100,000, CONTRACTOR shall provide CITY with a Performance Bond and a Payment Bond in the amount of one hundred percent (100%) of the contract amount.

**5.12.02** Failure by CONTRACTOR to perform the work in a timely or satisfactory fashion may result in forfeiture of CONTRACTOR'S Performance Bond.

**5.12.03** If the surety on any bond furnished by CONTRACTOR becomes a party to supervision, liquidation, or rehabilitation action pursuant Indiana Code 27-9 et seq. or its right to do business in the State of Indiana is terminated, CONTRACTOR shall, within thirty (30) calendar days thereafter, substitute another bond and surety, both of which must be acceptable to CITY.

**5.13 Payment of Subcontractors** CONTRACTOR shall pay all subcontractors, laborers, material suppliers and those performing services to CONTRACTOR on the project under this Agreement. CITY may, as a condition precedent to any payment hereunder, require CONTRACTOR to submit satisfactory evidence of payments of any and all claims of subcontractors, laborers, material suppliers, and those furnishing services to CONTRACTOR. Upon receipt of a lawful claim, CITY shall withhold money due to CONTRACTOR in a sufficient amount to pay the subcontractors, laborers, material suppliers, and those furnishing services to CONTRACTOR.

**5.13.01** The surety of the Payment Bond and Performance Bond may not be released until one (1) year after the Board's final settlement with the CONTRACTOR.

**5.14 Written Notice** Written notice shall be considered as served when delivered in person or sent by mail to the individual, firm, or corporation, or to the last business address of such known to CONTRACTOR who serves the Notice. Notice shall be sent as follows:

TO CITY:

TO CONTRACTOR:

City of Bloomington	Bluestone Tree
Attn: Roy Aten	Attn: Tiffany Oren
P.O. Box 100 Suite 130	3090 S. Walnut St.
Bloomington, Indiana 47402	Bloomington, IN 47401

**5.15 Severability and Waiver** In the event that any clause or provision of this Agreement is held to be invalid by any court of competent jurisdiction, the invalidity of such clause or provision shall not affect any other provision of this Agreement. Failure of either party to insist on strict compliance with any provision of this Agreement shall not constitute waiver of that party's right to demand later compliance with the same or other provisions of this Agreement.

**5.16 Notice to Proceed** CONTRACTOR shall not begin the work pursuant to the "Scope of Work" of this Agreement until it receives an official written Notice to Proceed from the City. Contractor shall start active and continuous work on the Agreement within fifteen (15) calendar days after the date of the Notice to Proceed. In no case shall work begin prior to the date of the Notice to Proceed. If a delayed starting date is indicated in the proposal, the fifteen (15) calendar day limitation will be waived. Work day charges will then begin on a date mutually agreed upon, but not later than the delayed starting date specified. In the event that any Agreement is canceled after an award has been made but prior to the issuing of the Notice to Proceed, no reimbursement will be made for any expenses accrued relative to this contract during that period.

**5.17 Steel or Foundry Products**

**5.17.01** To comply with Indiana Code 5-16-8, affecting all contracts for the construction, reconstruction, alteration, repair, improvement or maintenance of public works, the following provision shall be added: If steel or foundry products are to be utilized or supplied in the performance of any contract or subcontract, only domestic steel or foundry products shall be used. Should CITY feel that the cost of domestic steel or foundry products is unreasonable; CITY will notify CONTRACTOR in writing of this fact.

**5.17.02** Domestic Steel products are defined as follows:

"Products rolled, formed, shaped, drawn, extruded, forged, cast, fabricated or otherwise similarly processed, or processed by a combination of two (2) or more of such operations, from steel made in the United States by open hearth, basic oxygen, electric furnace, Bessemer or other steel making process."

**5.17.03** Domestic Foundry products are defined as follows:

"Products cast from ferrous and nonferrous metals by foundries in the United States."

**5.17.04** The United States is defined to include all territory subject to the jurisdiction of the United States.

**5.17.05** CITY may not authorize or make any payment to CONTRACTOR unless CITY is satisfied that CONTRACTOR has fully complied with this provision.

**5.18 Verification of Employees' Immigration Status**

Contractor is required to enroll in and verify the work eligibility status of all newly-hired employees through the E-Verify program. (This is not required if the E-Verify program no longer exists). Contractor shall sign an affidavit, attached as Attachment C, affirming that Contractor does not knowingly employ an unauthorized alien. "Unauthorized alien" is defined at 8 U.S. Code 1324a(h)(3) as a person who is not a U.S. citizen or U.S. national and is not lawfully admitted for permanent residence or authorized to work in the U.S. under 8 U.S. Code Chapter 12 or by the U.S. Attorney General.

Contractor and any of its subcontractors may not knowingly employ or contract with an unauthorized alien, or retain an employee or contract with a person that the Contractor or any of its subcontractors learns is an unauthorized alien. If the City obtains information that the Contractor or any of its subcontractors employs or retains an employee who is an unauthorized alien, the City shall notify the Contractor or its subcontractors of the Agreement violation and require that the violation be remedied within thirty (30) calendar days of the date of notice. If the Contractor or any of its subcontractors verify the work eligibility status of the employee in question through the E-Verify program, there is a rebuttable presumption that the Contractor or its subcontractor did not knowingly employ an unauthorized alien. If the Contractor or its subcontractor fails to remedy the violation within the thirty (30) calendar day period, the City shall terminate the Agreement, unless the City determines that terminating the Agreement would be detrimental to the public interest or public property, in which case the City may allow the Agreement to remain in effect until the City procures a new contractor. If the City terminates the Agreement, the Contractor or its subcontractor is liable to the City for actual damages.

Contractor shall require any subcontractors performing work under this Agreement to certify to the Contractor that, at the time of certification, the subcontractor does not knowingly employ or contract with an unauthorized alien and the subcontractor has enrolled in and is participating in the E-Verify program. Contractor shall maintain on file all subcontractors' certifications throughout the term of this Agreement with the City.

**5.19 Drug Testing Plan**

In accordance with Indiana Code 4-13-18 as amended, the CONTRACTOR was required to submit with his/her bid a written drug testing policy for a public works project that is estimated to cost \$150,000 or more. Among other things, the law sets forth specific requirements that must be in the plan for a program to test the employees of the CONTRACTOR and Subcontractors for drugs. The successful CONTRACTOR must comply with all provisions of the statute. This contract is subject

to cancellation if CONTRACTOR fails to implement its testing program during the term of this contract, fails to provide information regarding this testing at the request of CITY; or provides false information to CITY regarding CONTRACTOR'S employee drug testing program. CONTRACTOR shall sign an affidavit, attached as Attachment D, affirming that CONTRACTOR has and shall implement CONTRACTOR'S employee drug testing program throughout the term of this project.

**5.20 Living Wage Ordinance**

Contractors that are considered "covered employers" under City Ordinance 2.28, otherwise known as the "Living Wage Ordinance," or "LWO," are required to pay their covered employees at least a living wage. Currently, the living wage is \$15.29 per hour for covered employees, and up to 15% of that amount, \$2.29, may be in the form the covered employer's contribution to health insurance available to the covered employee.

If CONTRACTOR is determined to be a covered employer under the LWO, CONTRACTOR shall execute the Living Wage Ordinance Affidavit, attached as Exhibit F; shall abide by the LWO by paying their employees a living wage; and shall post the Living Wage Poster, provided by the City Legal Department, in areas frequented by their covered employees.

IN WITNESS WHEREOF, the parties of this Agreement have hereunto set their hands.

DATE: \_\_\_\_\_

City of Bloomington  
Bloomington Board of Public Works

BY:

BY:

\_\_\_\_\_  
Kyla Cox Deckard, President

\_\_\_\_\_  
Contractor Representative

\_\_\_\_\_  
Elizabeth Karon, Vice President

\_\_\_\_\_  
Printed Name

\_\_\_\_\_  
Jennifer Lloyd, Secretary

\_\_\_\_\_  
Title of Contractor Representative

\_\_\_\_\_  
John Hamilton, Mayor of Bloomington

## **ATTACHMENT 'A'**

### **"SCOPE OF WORK"**

#### **B-Line Extension Tree Clearing**

This project shall include, but is not limited to, the removal of selected trees along the proposed B-Line Extension Project.

**ATTACHMENT 'B'**

**BIDDER'S AFFIDAVIT IN COMPLIANCE WITH INDIANA CODE 36-1-12-20 TRENCH SAFETY SYSTEMS;  
COST RECOVERY**

STATE OF INDIANA )  
 ) SS:  
COUNTY OF Monroe )

**AFFIDAVIT**

The undersigned, being duly sworn, hereby affirms and says that:

1. The undersigned is the Owner of Bluestone Tree, Inc.  
(job title)  
(company name)
2. The undersigned is duly authorized and has full authority to execute this Bidder's Affidavit.
3. The company named herein that employs the undersigned:
  - i. has contracted with or seeking to contract with the City of Bloomington to provide services; **OR**
  - ii. is a subcontractor on a contract to provide services to the City of Bloomington.
4. By submission of this Bid and subsequent execution of a Contract, the undersigned Bidder certifies that as successful Bidder (Contractor) all trench excavation done within his/her control (by his/her own forces or by his/her Subcontractors) shall be accomplished in strict adherence with OSHA trench safety standards contained in 29 C.F.R. 1926, Subpart P, including all subsequent revisions or updates to these standards as adopted by the United States Department of Labor.
5. The undersigned Bidder certifies that as successful Bidder (Contractor) he/she has obtained or will obtain identical certification from any proposed Subcontractors that will perform trench excavation prior to award of the subcontracts and that he/she will retain such certifications in a file for a period of not less than three (3) years following final acceptance.
6. The Bidder acknowledges that included in the various items listed in the Schedule of Bid Prices and in the Total Amount of Bid Prices are costs for complying with I.C. 36-1-12-20. The Bidder further identifies the costs to be summarized below\*:

	Trench Safety Measure	Units of Measure	Unit Cost	Unit Quantity	Extended Cost
A.	N/A				
B.					
C.					
D.					
				Total	\$ <u>N/A</u>

Method of Compliance (Specify) \_\_\_\_\_

Date: 21 20, 2023

Jeff Oren  
Signature

Tiffany Oren  
Printed Name

STATE OF INDIANA )  
 ) SS:  
COUNTY OF Monroe )

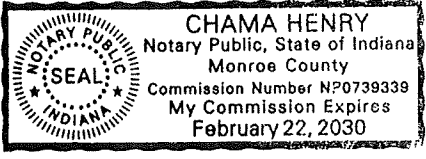

Before me, a Notary Public in and for said County and State, personally appeared T. Tiffany Oren and acknowledged the execution of the foregoing this 20<sup>th</sup> day of February, 2023.

My Commission Expires: 2/22/2030

Chama Henry  
Signature of Notary Public

County of Residence: Monroe

Chama Henry  
Printed Name of Notary Public

Commission #: NP0739339

\*Bidders: Add extra sheet(s), if needed.

If Bidder fails to complete and execute this sworn affidavit, his/her Bid may be declared nonresponsive and rejected by the **CITY OF BLOOMINGTON**.



ATTACHMENT 'C'

"E-Verify AFFIDAVIT"

STATE OF INDIANA )
)SS:
COUNTY OF Monroe )

E-Verify AFFIDAVIT

The undersigned, being duly sworn, hereby affirms and says that:

- 1. The undersigned is the Owner of Bluestone Tree, Inc.
a. (job title) (company name)
2. The company named herein that employs the undersigned:
i. has contracted with or seeking to contract with the City of Bloomington to provide services; OR
ii. is a subcontractor on a contract to provide services to the City of Bloomington.
3. The undersigned hereby states that, to the best of his/her knowledge and belief, the company named herein does not knowingly employ an "unauthorized alien," as defined at 8 United States Code 1324a(h)(3).
4. The undersigned hereby states that, to the best of his/her belief, the company named herein is enrolled in and participates in the E-verify program.

Signature [Handwritten Signature]

Printed Name Tiffany Oren

STATE OF INDIANA )
)SS:
COUNTY OF Monroe )

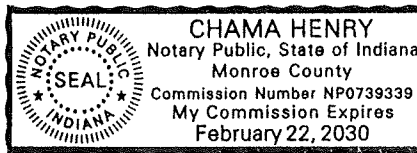

Before me, a Notary Public in and for said County and State, personally appeared Tiffany Oren and acknowledged the execution of the foregoing this 20th day of February, 2023.

My Commission Expires: 2/22/2030

Signature of Notary Public [Handwritten Signature]

County of Residence: Monroe

Printed Name of Notary Public Chama Henry

My Commission #: NP0739339

**ATTACHMENT 'D'**

**COMPLIANCE AFFIDAVIT**

**REGARDING INDIANA CODE CHAPTER 4-13-18**

**DRUG TESTING OF EMPLOYEES OF PUBLIC WORKS CONTRACTORS**

STATE OF INDIANA )  
 ) SS:

COUNTY OF Monroe )

AFFIDAVIT

The undersigned, being duly sworn, hereby affirms and says that:

1. The undersigned is the Owner of  
(job title)  
Bluestone Tree, Inc.  
(company name)
2. The undersigned is duly authorized and has full authority to execute this Affidavit.
3. The company named herein that employs the undersigned:
  - iii. has contracted with or seeking to contract with the City of Bloomington to provide services; **OR**
  - iv. is a subcontractor on a contract to provide services to the City of Bloomington.
4. The undersigned certifies that Contractor's submitted written plan for a drug testing program to test employees of the Contractor and Subcontractor for public works projects with an estimated cost of \$150,000 is in accordance with Indiana Code 4-13-18 as amended.
5. The undersigned acknowledges that this Contract shall be subject to cancellation should Contractor fail to comply all provisions of the statute.

  
\_\_\_\_\_  
Signature

Tiffany Oren  
\_\_\_\_\_  
Printed Name

STATE OF INDIANA )  
 )SS:  
COUNTY OF Monroe )

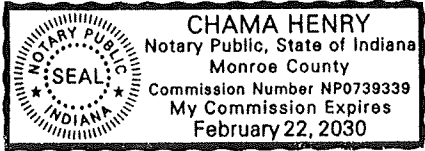

Before me, a Notary Public in and for said County and State, personally appeared Tiffany Oren  
and acknowledged the execution of the foregoing this 20<sup>th</sup> day of February, 2023.

My Commission Expires: 2/22/2030

Chama Henry  
Signature of Notary Public

County of Residence: Monroe

Chama Henry  
Printed Name of Notary Public

My Commission #: NP0739339



Project Title : B-Line Extension Tree Clearing

LINE	ITEM	DESCRIPTION	Approximate Quantity and Units	UNITS	UNIT PRICE	BID AMOUNT
001	201-02245	TREE, 6 IN, REMOVE	101	EACH	\$140.30	\$14,170.30
002	201-02250	TREE, 10 IN, REMOVE	38	EACH	\$153.46	\$5,831.48
003	201-02255	TREE, 18 IN, REMOVE	44	EACH	\$276.99	\$12,187.56
004	201-02260	TREE, 30 IN, REMOVE	16	EACH	\$517.97	\$8,287.52
005	201-02265	TREE, 48 IN, REMOVE	5	EACH	\$1,657.50	\$8,287.50
006	801-06775	MAINTENANCE OF TRAFFIC	1	LS	\$0.00	\$0.00

<b>TOTAL PROJECT BID:</b>	<b>\$48,764.36</b>
---------------------------	--------------------

Bidder acknowledges that

1. each Bid Unit Price includes an amount considered by Bidder to be adequate to cover Contractor's overhead and profit for each separately identified item, and
2. estimated quantities are not guaranteed, and are solely for the purpose of comparison of Bids, and final payment for all Unit Price Work will be based on actual quantities, determined as provided in the Contract Documents.

**EXHIBIT "F"**

**AFFIDAVIT THE LIVING WAGE ORDINANCE**

The undersigned, being duly sworn, hereby affirms and says that:

1. The undersigned is the \_\_\_\_\_ of Bluestone Tree, Inc.  
(job title) (company name)
  
2. The company named herein that employs the undersigned has contracted with or is seeking to contract with the City of Bloomington to provide services.
  
3. The undersigned hereby states that, to the best of their knowledge and belief, the company named herein is subject to Bloomington City Ordinance 2.28, otherwise known as the "Living Wage Ordinance."
  
4. The projected employment needs under the award include the following:
  
5. The projected net increase or decrease in jobs for covered employees by job title that will result from awarding the assistance:
  
6. The undersigned hereby affirms that the smallest hourly wage to be earned by each of their covered employees shall be at least the living wage.

I affirm under the penalties of perjury that the foregoing facts and information are true and correct to the best of my knowledge and belief.

\_\_\_\_\_

Signature

\_\_\_\_\_

Printed name

STATE OF INDIANA )

) SS:

COUNTY OF \_\_\_\_\_)

Before me, a Notary Public in and for said County and State, personally appeared \_\_\_\_\_  
\_\_\_\_\_ and acknowledged the execution of the foregoing this \_\_\_\_\_ day of \_\_\_\_\_, 2023.

My Commission Expires: \_\_\_\_\_

Notary Public

County of Residence: \_\_\_\_\_

Name Printed

\_\_\_\_\_  
Commission Number

# B-Line Extension Tree Clearing

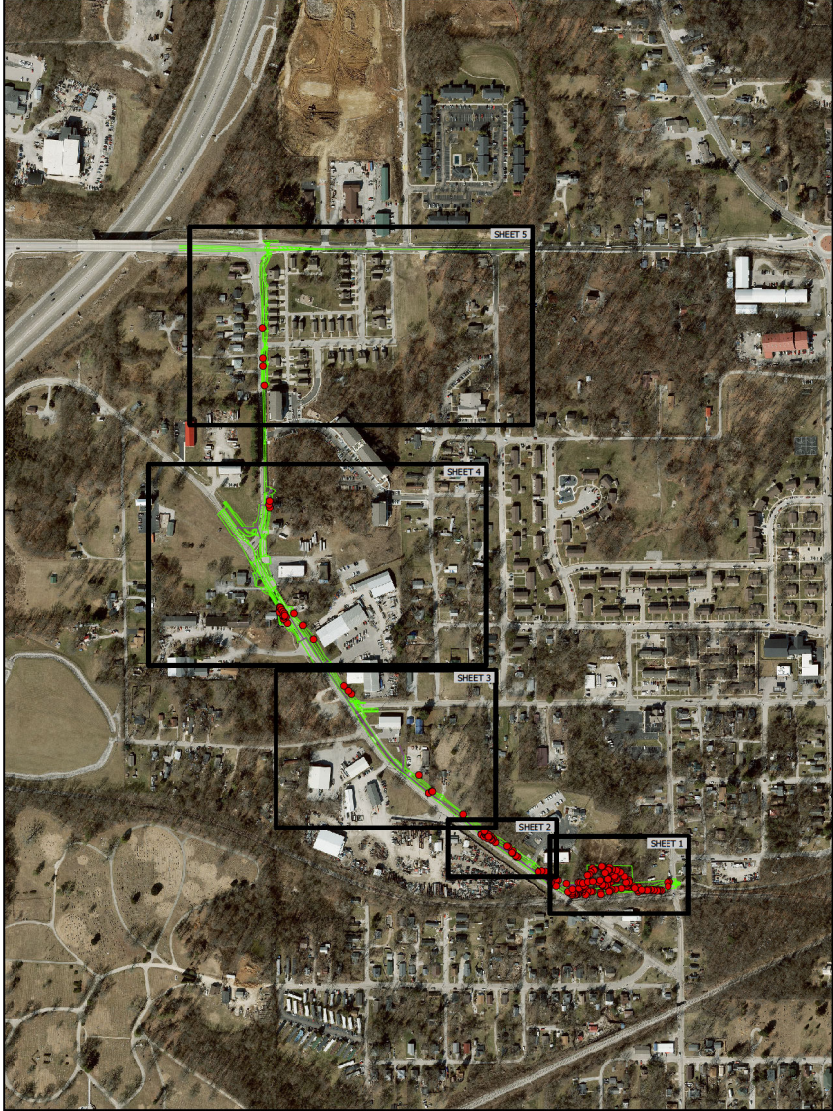

GENERAL NOTES
Contractor shall provide all required maintenance of traffic.
All trees must be cut down by March 31st, 2023. Trees must be removed from site by April 30th, 2023.
Contractor is responsible for tree cutting and removal of fallen trees. Stumps may remain.

**Legend**

- Tree
- Proposed Storm
- Trail and Construction Limits
- Tree (DBH)



**City of Bloomington**  
Engineering Department

**B-Line Extension Tree Clearing**

Produced: 2/10/2023

170 340 510 680 Feet

For use as map information only. Information is NOT warranted.





For use as a reference only. Information is not warranted.

**Legend**

- Tree
- Proposed Storm
- Proposed Trail and Construction Limits
- Tree (DBH)

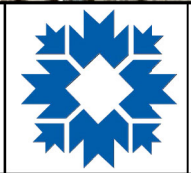

**City of Bloomington**  
Engineering Department

**B-Line Extension Tree Clearing**

Sheet 1 of 5

Produced: 2/10/2023

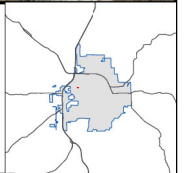





© 2023 City of Bloomington. All rights reserved. This map is for informational purposes only. The City of Bloomington is not responsible for any errors or omissions on this map. This map is not intended to be used for any other purpose.

For use as map information only. Not for navigation.

**Legend**

- Tree
- Proposed Storm Trail and Construction Limits
- # Tree (DBH)

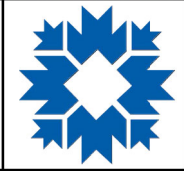

**City of Bloomington**  
Engineering Department

**B-Line Extension Tree Clearing**

Sheet 2 of 5

Produced: 2/10/2023





**Legend**

- Tree
- Proposed Storm
- Trail and Construction Limits
- # Tree (DBH)



**City of Bloomington**  
Engineering Department

**B-Line Extension Tree Clearing**

Sheet 3 of 5

Produced: 2/13/2023

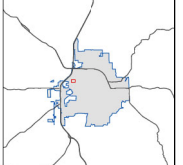





DO NOT REMOVE THESE THREE TREES UNTIL APPROVED BY CITY.

# 302 (14)  
# 300 (14)  
# 294 (4)  
# 198 (15)  
# 296 (4)  
# 195 (10)  
# 193 (7)  
# 191 (20)  
# 190 (11)  
# 201 (14)  
# 199 (7)  
# 197 (0)  
# 194 (4)  
# 192 (20)



**Legend**

- Tree
- Proposed Storm
- Trail and Construction Limits

# 199(7)

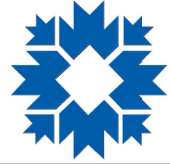

**City of Bloomington**  
Engineering Department

**B-Line Extension Tree Clearing**

Sheet 4 of 5

Produced: 2/10/2023

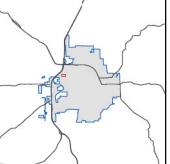



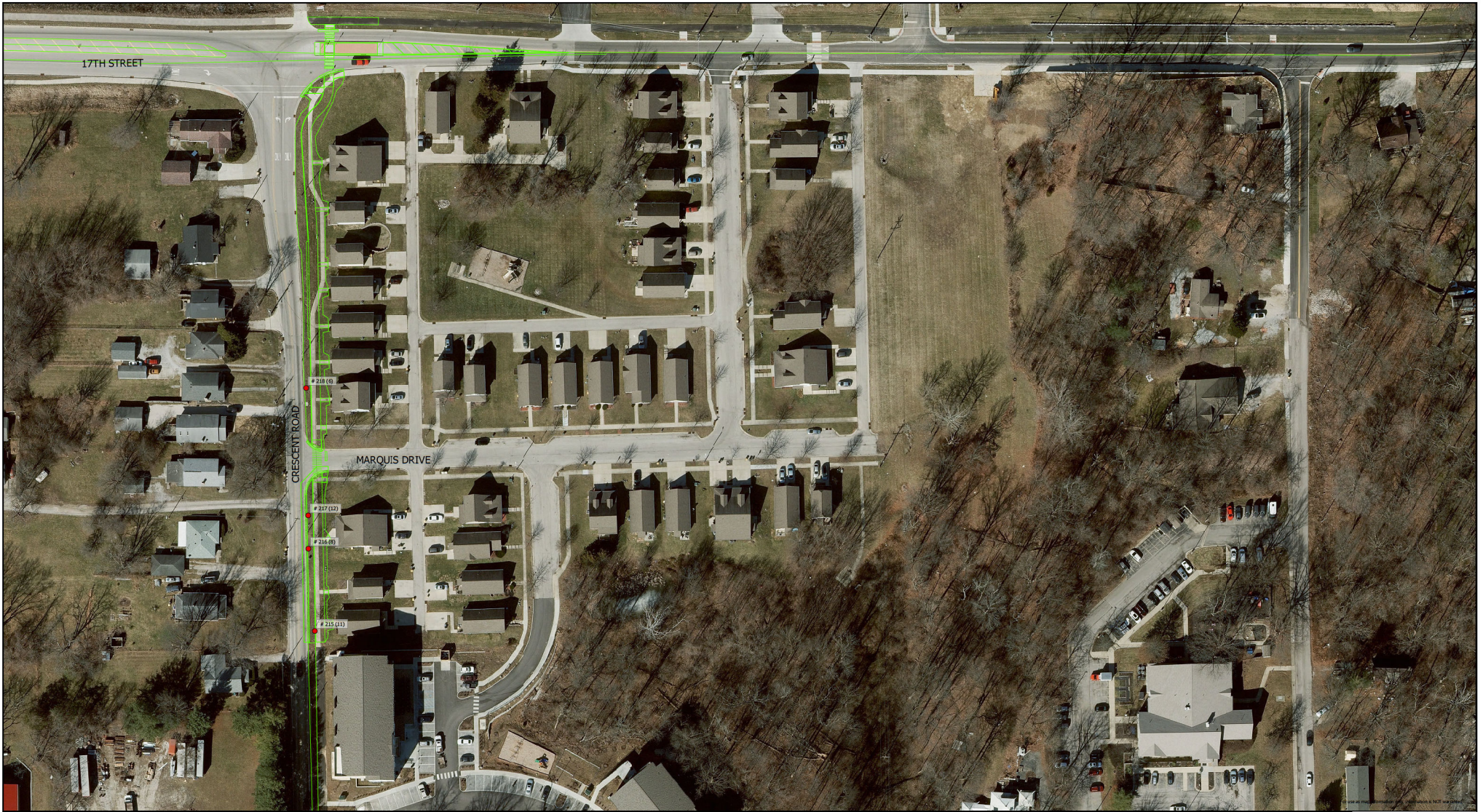

**Legend**

- Tree
- Proposed Storm
- Trail and Construction Limits
- #Tree (DBH)



**City of Bloomington**  
Engineering Department

**B-Line Extension Tree Clearing**  
Sheet 5 of 5

Produced: 2/19/2023

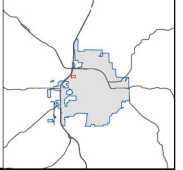





## Board of Public Works Staff Report

---

**Project/Event:** Resolution 2023-10 Public Need to Purchase Right of Way for the Adams Street Sidewalk (Kirkwood to Fountain) Project

**Petitioner/Representative:** Engineering Department

**Staff Representative:** Patrick Dierkes, Project Engineer

**Date:** 02/28/2023

---

**Report:** This project will construct a sidewalk on the west side of Adams Street from Kirkwood Ave to Fountain Drive, including accessible curb ramps. This project was programmed through the Council Sidewalk Committee and has received additional funding support with a Community Development Block Grant of \$140,000. The existing right of way width of Adams Street does not provide sufficient space for the proposed sidewalk so the project requires acquisition of additional rights of way from seven parcels.

If approved by the Board, this resolution will confirm that the Project serves a public purpose and will authorize the right of way acquisition.

---

<u>Project Approvals Timeline</u>		
<u>Approval Type</u>	<u>Status</u>	<u>Date</u>
Funding Approval – Council Sidewalk & CDBG	Approved	2023
Design Services Contract	Approved	12/08/2020
ROW Services Contract	Approved	07/19/2022
<b>Public Need Resolution</b>	<b>Current Item</b>	<b>02/28/2023</b>
Construction Inspection Contract	N/A	--
Construction Contract	Pending	Summer 2023

**RESOLUTION 2023-10  
BOARD OF PUBLIC WORKS  
CITY OF BLOOMINGTON, INDIANA**

**WHEREAS**, the City of Bloomington through its Board of Public Works (“City) intends to construct a sidewalk on the west side of Adams Street from Kirkwood Avenue to Fountain Drive, including accessible curb ramps; and

**WHEREAS**, the City has determined that there is a need for the project, and that it will serve a public purpose and be of public benefit, and has appropriated money to finance construction of the project; and

**WHEREAS**, it is necessary to acquire land/or easement for construction of the project from the property owners listed in Attachment A, incorporated herein by reference; and

**NOW, THEREFORE**, be it hereby resolved by the City that:

1. The project serves a public purpose and will benefit the citizens of Bloomington and Monroe County, Indiana.
2. The acquisition of the land and easements from the property owners listed on Attachment A is hereby authorized. In the event the City is unable to reach agreement with a property owner regarding the purchase of the land or easement within thirty (30) days after the issuance of a formal offer to purchase, as provided in Indiana Code § 32-24-1-5, the City is hereby authorized to commence eminent domain proceedings.

**SO PASSED AND ADOPTED this \_\_\_\_ day of \_\_\_\_\_, 2023, by the City of Bloomington Board of Public Works**

\_\_\_\_\_  
Kyla Cox-Deckard, President

\_\_\_\_\_  
Elizabeth Karon, Vice President

\_\_\_\_\_  
Jennifer Lloyd, Secretary

ATTACHMENT A

<b><u>Parcel</u></b>	<b><u>Owner</u></b>	<b><u>Address</u></b>
1	Matthew R. Murphy	103-113 North Adams Street
2	JKM Associates LLC	141 North Adams Street
3	Gloria Gibson	201 North Adams Street
4	Todd & Jack Berger	221 North Adams Street
5	Braden Beetz	223 North Adams Street
6	Joseph Christine, LLC	227, 231 & 233 North Adams Street
7	ELM Rentals, LLC	301 North Adams Street





## Board of Public Works Staff Report

---

**Project/Event:** Atlantic Engineering Group (AEG)  
**Staff Representative:** Jason Kerr  
**Petitioner/Representative:** Bret Simons  
**Date:** February 28, 2023

---

**Report:** AEG is requesting lane closures and sidewalk closures in multiple locations of their project work areas. This request is to accommodate work on fiber installation via boring and aerial fiber installation. The traffic control would be in place from March 3rd through end of project, which we're estimating to be 4 weeks per project area.

AEG has supplied various maintenance of traffic plans for all work. They are also placing door hangers for public notice to property owners about scope of their work and contact information for if there are any issues. (see packet for details).

AEG is requesting for 3 area projects to be granted through this BPW meeting. The following areas include...

E University St	North to south, this is between E 3 <sup>rd</sup> St and E Maxwell Ln West to east, this is between S Woodlawn and S Clifton Ave
E Tamarack Trl	North to south, this is between Ramble Rd Ct and 46 Bypass West to east, this is between N walnut and N Headley Rd
W Acuff Rd	North to south, this is between W Bayles RD and Arlington Rd Following north on Kinser Pike



P.O. Box 349 | Buford, Georgia 30515  
Main Office: (706)654-2298  
[www.aeg.cc](http://www.aeg.cc)

To: City of Bloomington – Engineering Department  
Subject: City of Bloomington Right of Way Application

Dear Board Members,

Atlantic Engineering Group is planning a large FTTH project across the entire City of Bloomington. This work will take place at different locations throughout the year. In order to facilitate these up coming projects, AEG is respectfully requesting access the to ROW as planned out in the submitted permits.

Traffic control plans will be attached to each permit. No long-term road closures or sidewalk closures are expected. Signs and flaggers will be present when needed and move with the project as it moves throughout the city. The areas will all be identified on the plans we submit to the cities Engineering Department.

Proper door hangers will be placed prior to the construction starting in a particular area. The door hangers will provide information about the construction and contact information if any issues arise.

Bret Simons  
Project Coordinator  
Atlantic Engineering Group



## Fiber Optic Internet is Coming to Your Neighborhood!

Over the next several weeks there will be construction crews in your area building a new fiber optic network. Fiber is the fastest and most reliable technology to deliver internet and Wi-Fi services.

Before we begin building, we must determine the location of existing underground utilities. Construction areas will be marked with flags and paint that should remain in place for the duration of construction.

Please feel free to mark any private underground facilities that you believe are in the right of way. Examples of private facilities are: Sprinkler systems, dog fences, private gas line, pool systems, etc..

For additional information please call  
(812)-269-8805.





**Fiber Internet is coming  
to Bloomington!**

**You can subscribe now!**

## **Get the Fastest Internet in Town**

- ✓ Same Speeds Up and Down
- ✓ Ultimate Gaming with No Lag
- ✓ Stream without Buffering
- ✓ Video Chats without Interruption
- ✓ Use **All** Your Devices, **All** at the Same Time — No Problem!



**GigabitNow**  
**INDIANA**

Internet How It Is Meant To Be

[www.GigabitNowIndiana.com](http://www.GigabitNowIndiana.com)



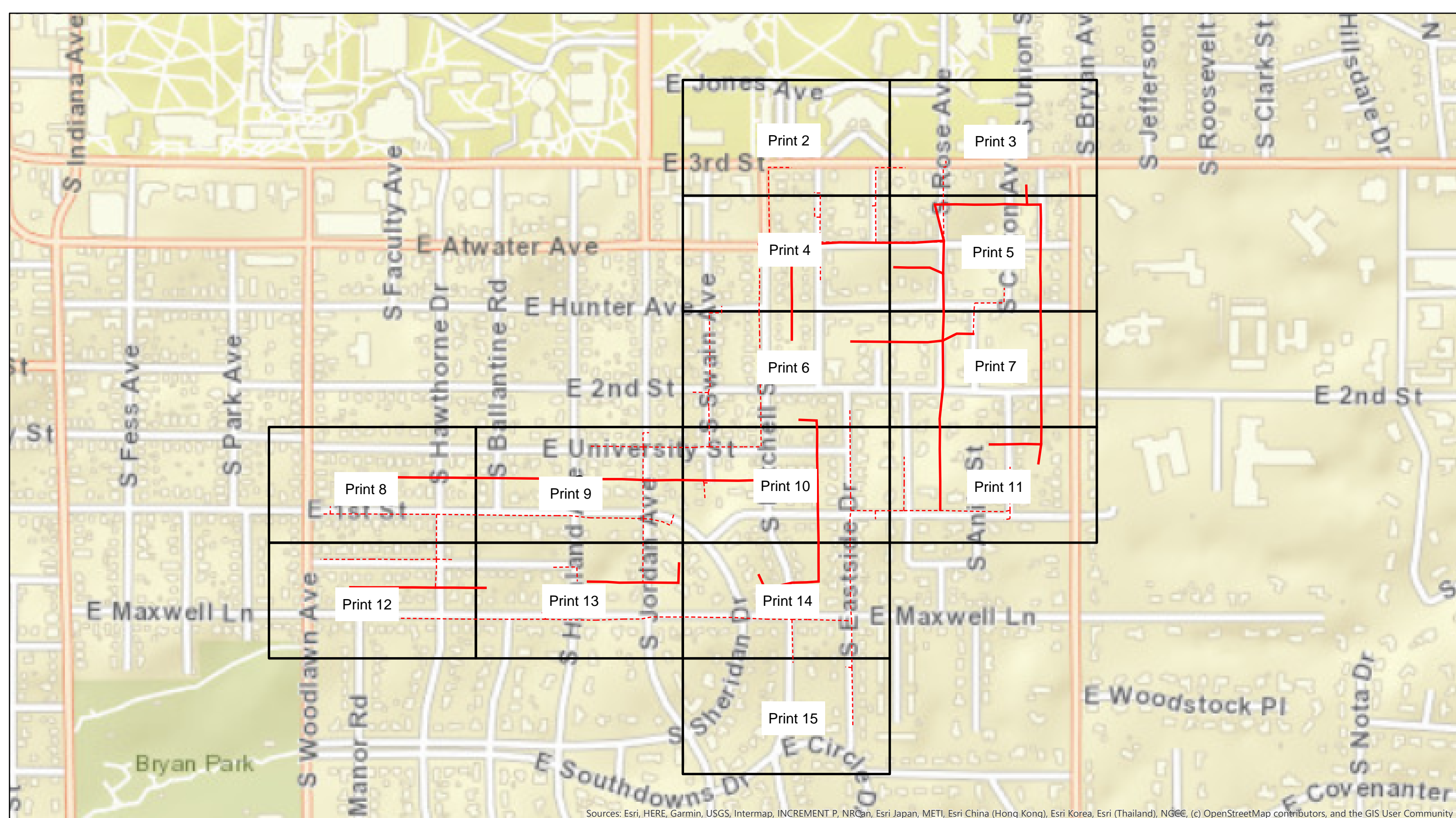

Sources: Esri, HERE, Garmin, USGS, Intermap, INCREMENT P, NRCan, Esri Japan, METI, Esri China (Hong Kong), Esri Korea, Esri (Thailand), NGCC, (c) OpenStreetMap contributors, and the GIS User Community



BLC01b-F14 - E University St

- Overhead Strand
- - - Conduit
- Grids



City of Bloomington, IN Permit:  
Design View

INI	BY	DATE	DESCRIPTION

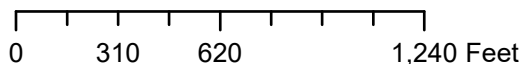

E Jones AVE

1700 E JONES AVE

1725 E 3RD ST

1603 E 3RD ST

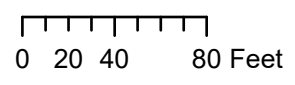
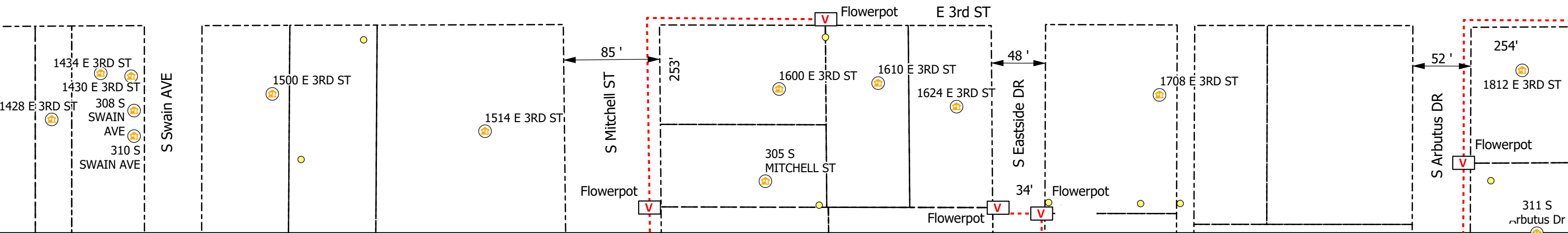

**Legend**

- Poles
- V Vaults
- Overhead Strand
- Conduit
- Bloomington\_Parcels
- R Risers
- A Address
- Y Anchor
- K Sidewalk
- Grids

All Flowerpots 12" DIA



City of Bloomington, IN Permit:  
Design View

INI	BY	DATE	DESCRIPTION





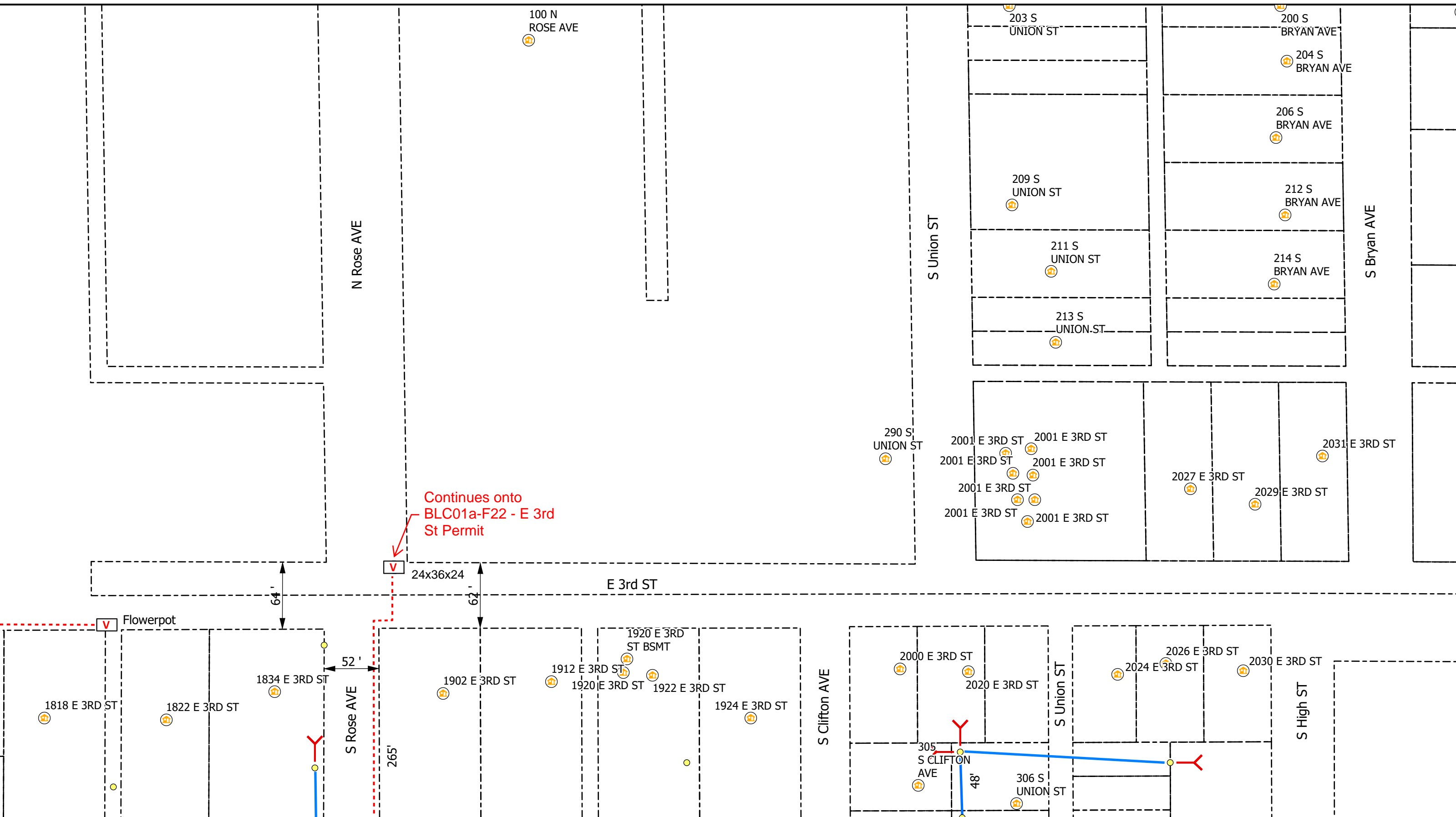

Continues onto  
BLC01a-F22 - E 3rd  
St Permit

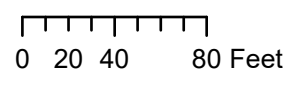

**Legend**

- Poles
- V Vaults
- Overhead Strand
- Conduit
- Bloomington\_Parcels
- R Risers
- A Address
- Y Anchor
- ← Sidewalk
- Grids

All Flowerpots 12" DIA



City of Bloomington, IN Permit:  
Design View

INI	BY	DATE	DESCRIPTION



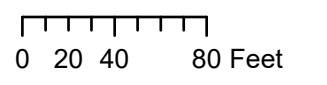
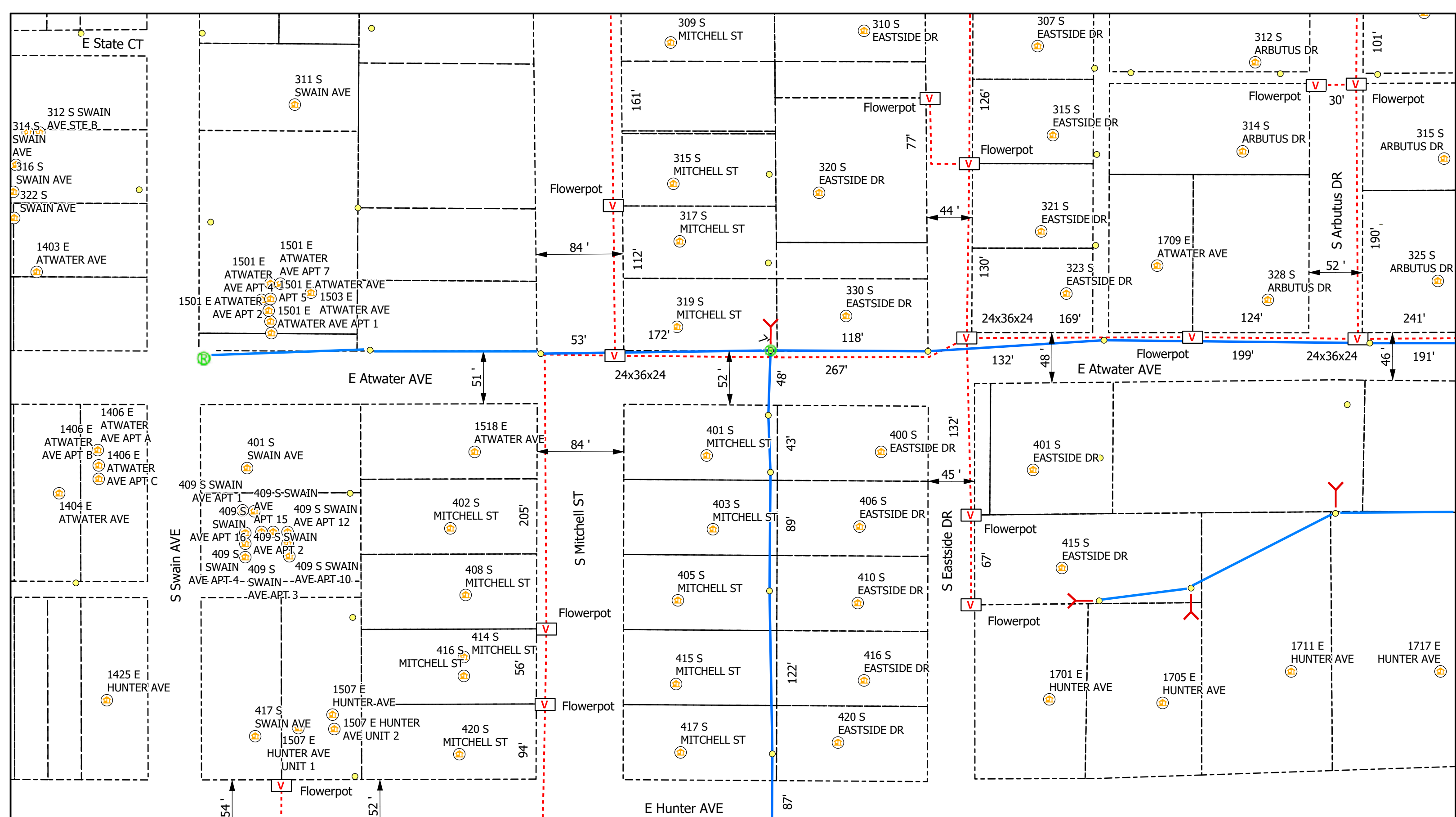

**Legend**

- Poles
- Vaults
- Overhead Strand
- Conduit
- Bloomington\_Parcels
- Risers
- Address
- Anchor
- Sidewalk
- Grids

All Flowerpots 12" DIA



City of Bloomington, IN Permit:  
Design View

INI	BY	DATE	DESCRIPTION



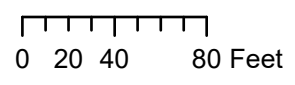
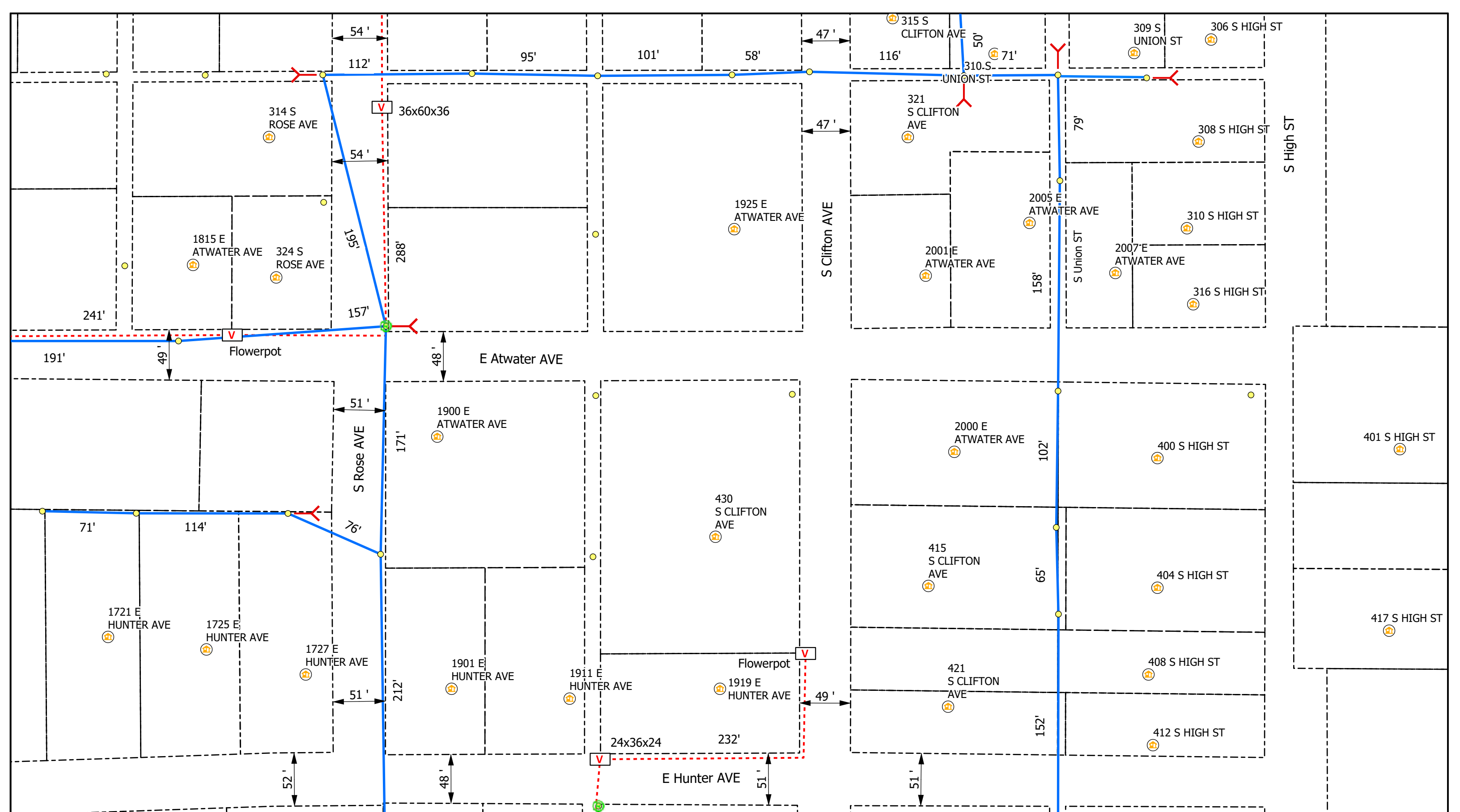

**Legend**

- Poles
- Vaults
- Overhead Strand
- Conduit
- Bloomington\_Parcels
- Risers
- Address
- Anchor
- Sidewalk
- Grids

All Flowerpots 12" DIA



City of Bloomington, IN Permit:  
Design View

INI	BY	DATE	DESCRIPTION



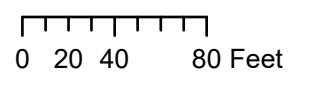
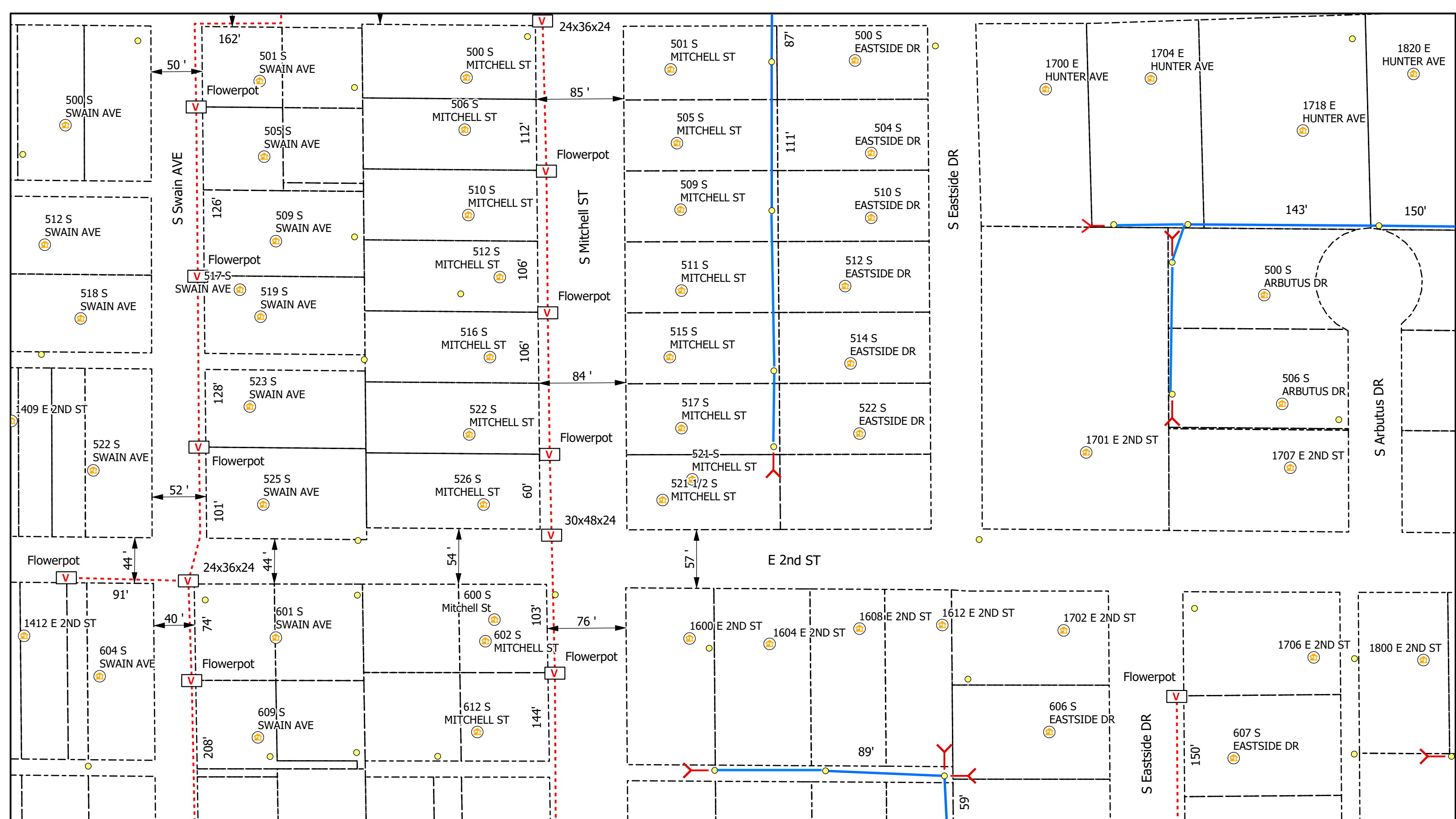

**Legend**

- Poles
- V Vaults
- Overhead Strand
- Conduit
- Bloomington\_Parcels
- R Risers
- A Address
- Y Anchor
- ← Sidewalk
- Grids

All Flowerpots 12" DIA



City of Bloomington, IN Permit:  
Design View

INI	BY	DATE	DESCRIPTION



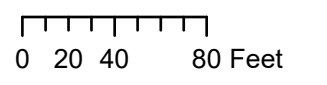
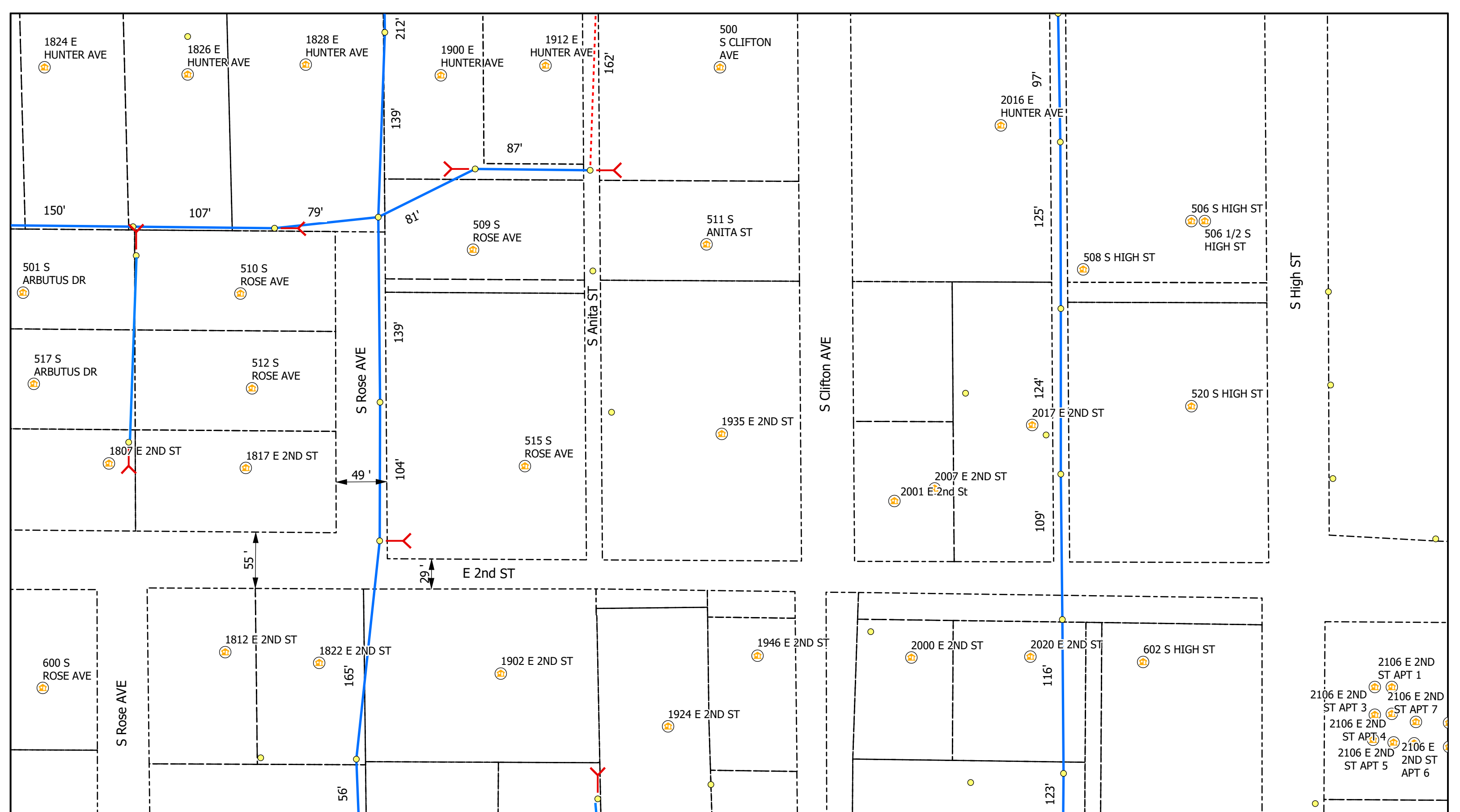

**Legend**

- Poles
- Vaults
- Overhead Strand
- Conduit
- Bloomington\_Parcels
- Risers
- Address
- Anchor
- Sidewalk
- Grids

All Flowerpots 12" DIA



City of Bloomington, IN Permit:  
Design View

INI	BY	DATE	DESCRIPTION





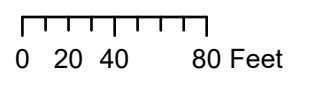
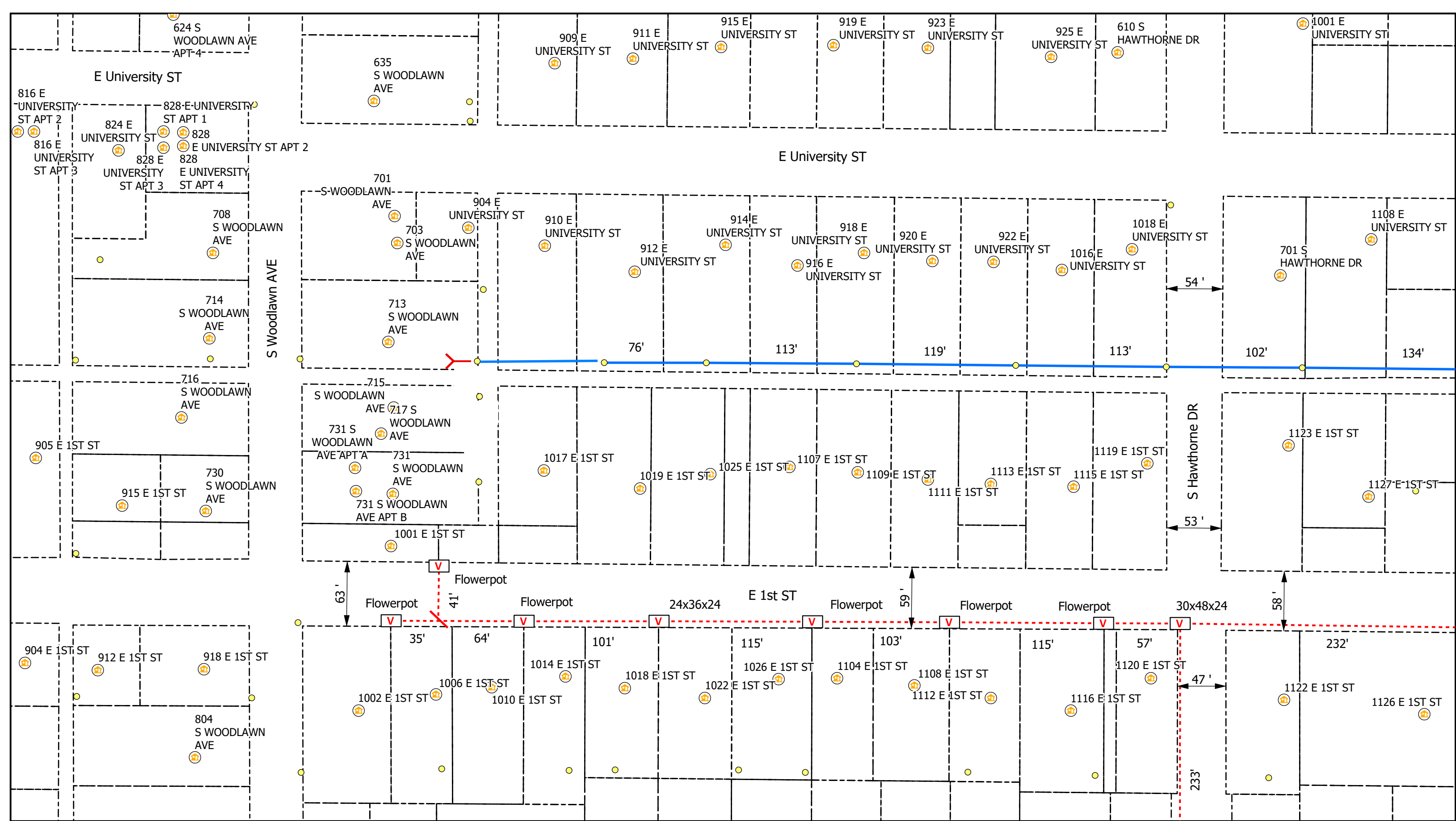

**Legend**

- Poles
- V Vaults
- Overhead Strand
- Conduit
- Bloomington\_Parcels
- R Risers
- Ⓜ Address
- Y Anchor
- ← Sidewalk
- Grids

All Flowerpots 12" DIA



City of Bloomington, IN Permit:  
Design View

INI	BY	DATE	DESCRIPTION





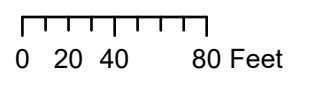
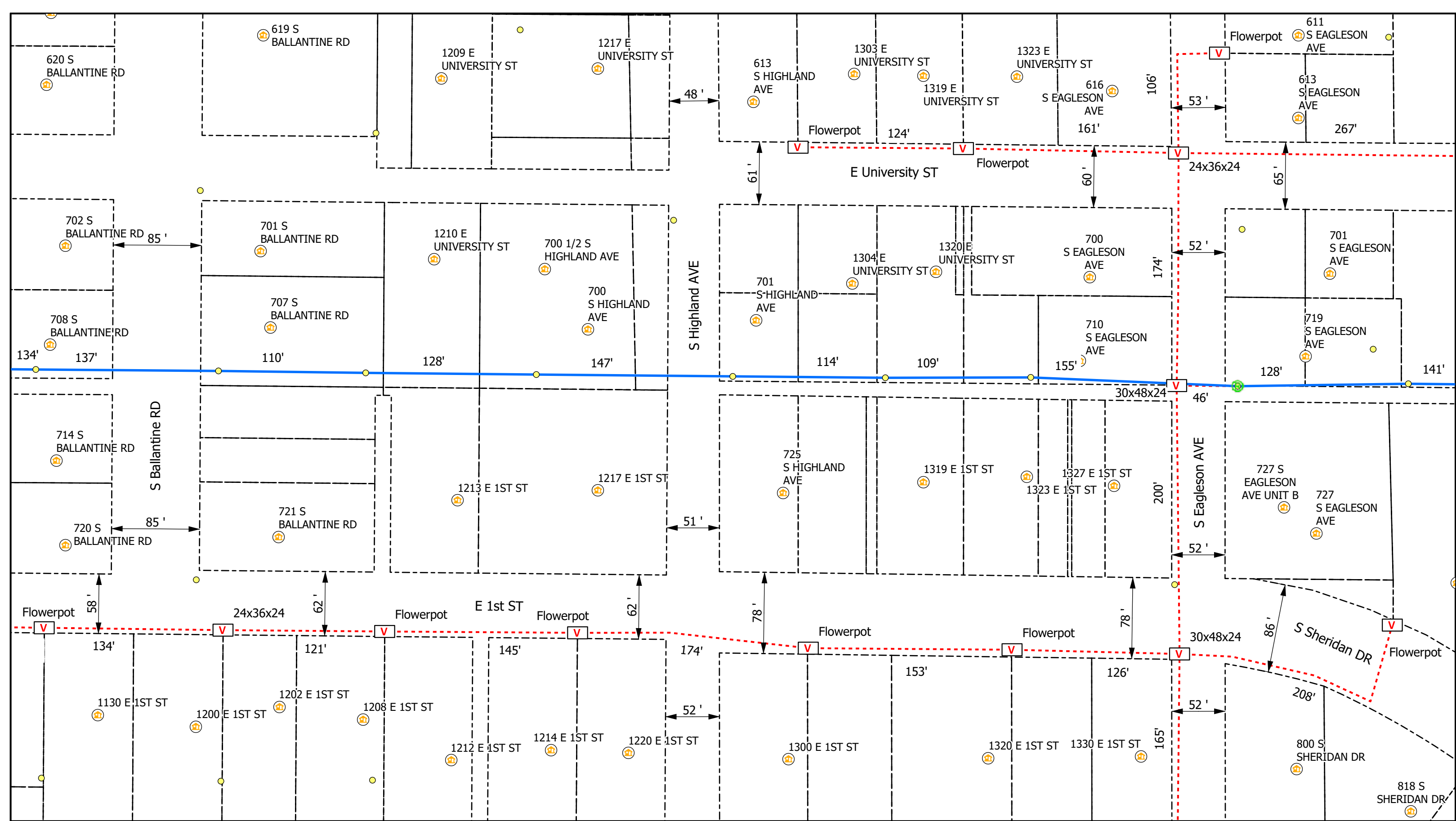

**Legend**

- Poles
- V Vaults
- Overhead Strand
- Conduit
- Bloomington\_Parcels
- R Risers
- Ⓜ Address
- Y Anchor
- ← Sidewalk
- Grids

All Flowerpots 12" DIA



City of Bloomington, IN Permit:  
Design View

INI	BY	DATE	DESCRIPTION



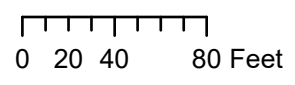
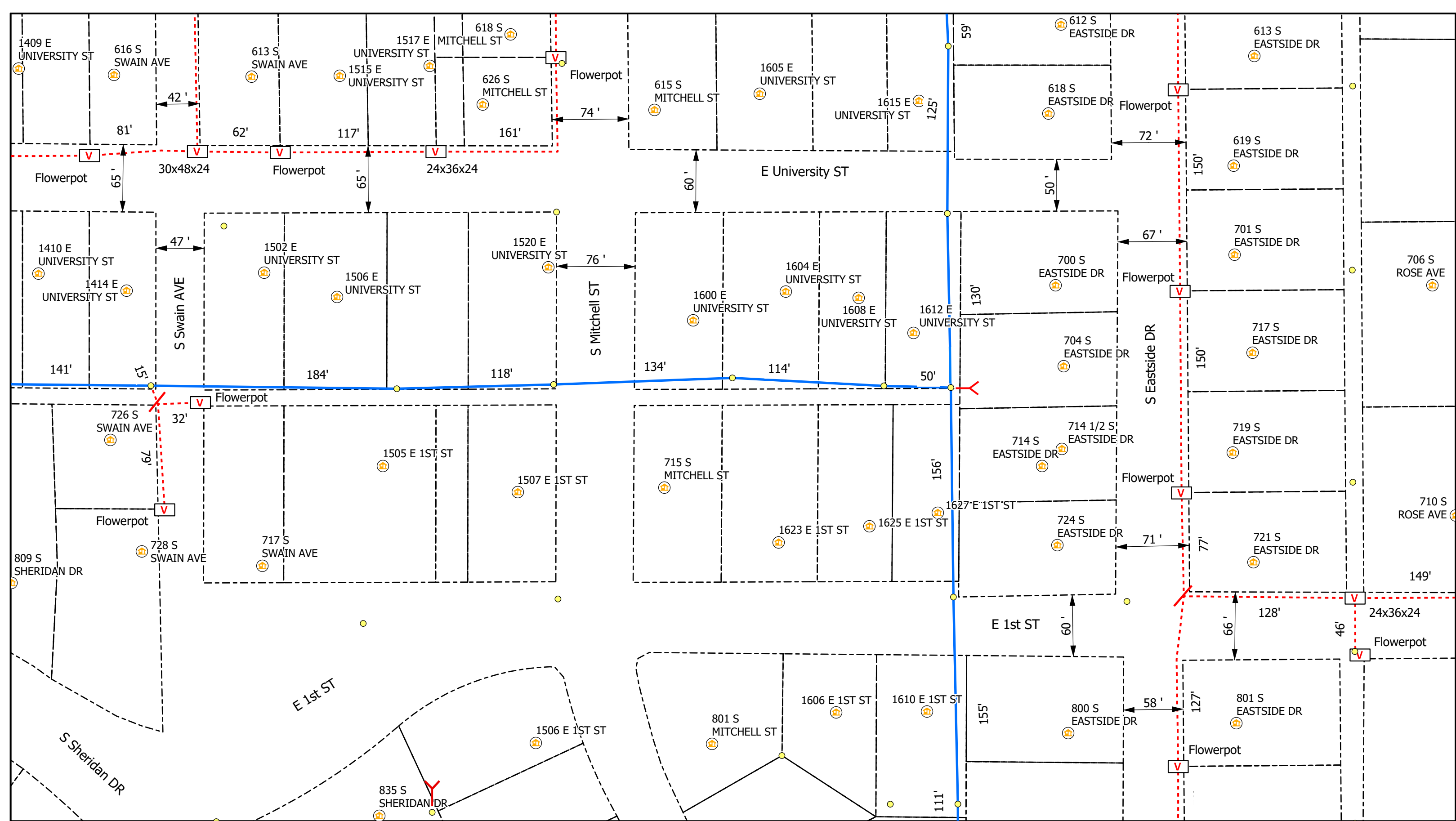

**Legend**

- Poles
- Vaults
- Overhead Strand
- Conduit
- Bloomington\_Parcels
- Risers
- Address
- Anchor
- Sidewalk
- Grids

All Flowerpots 12" DIA



City of Bloomington, IN Permit:  
Design View

INI	BY	DATE	DESCRIPTION



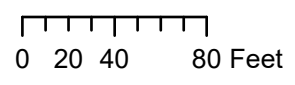
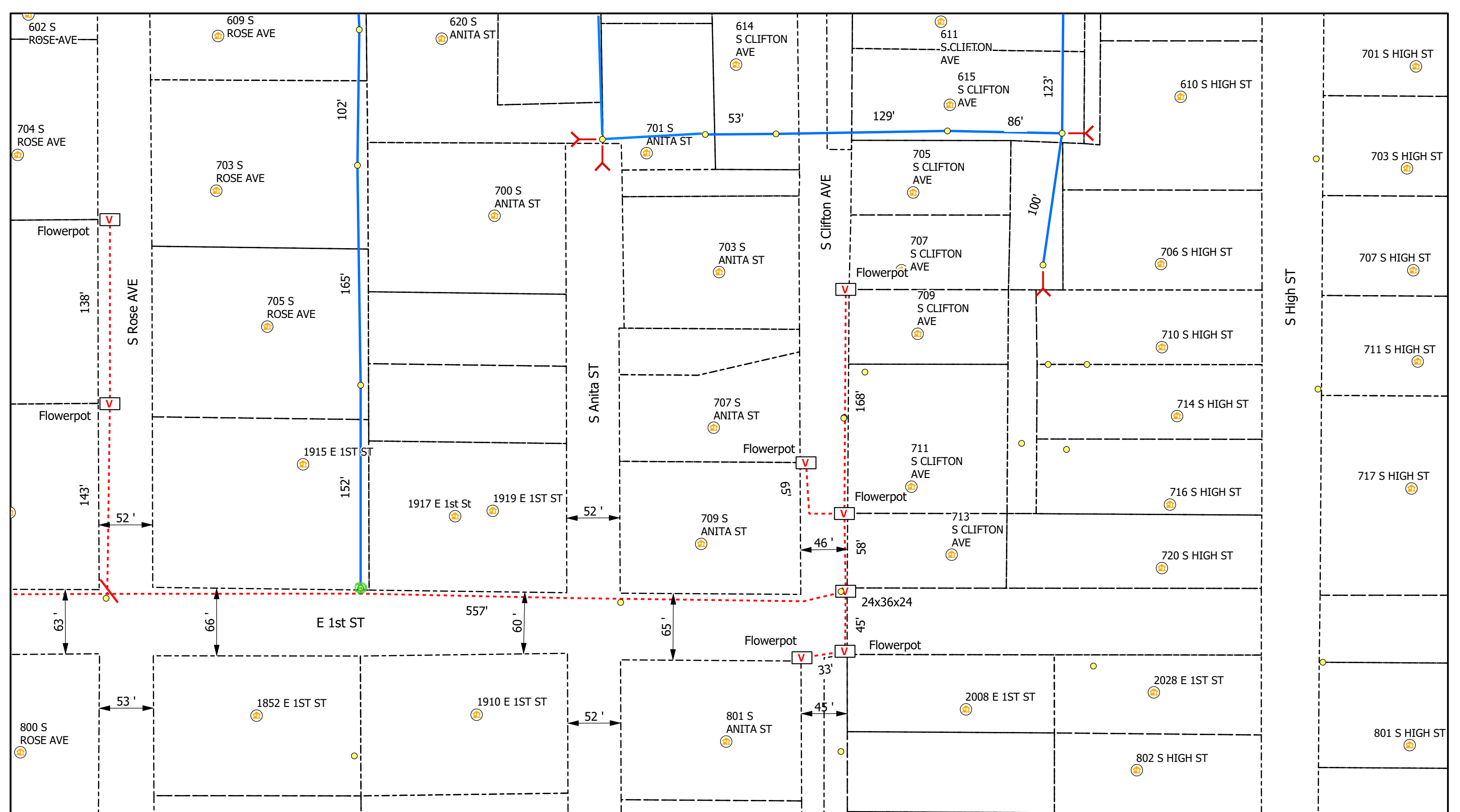

### Legend

- Poles
- Vaults
- Overhead Strand
- Conduit
- Bloomington\_Parcels
- Risers
- Address
- Anchor
- Sidewalk
- Grids

All Flowerpots 12" DIA



City of Bloomington, IN Permit:  
Design View

INI	BY	DATE	DESCRIPTION



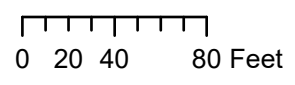
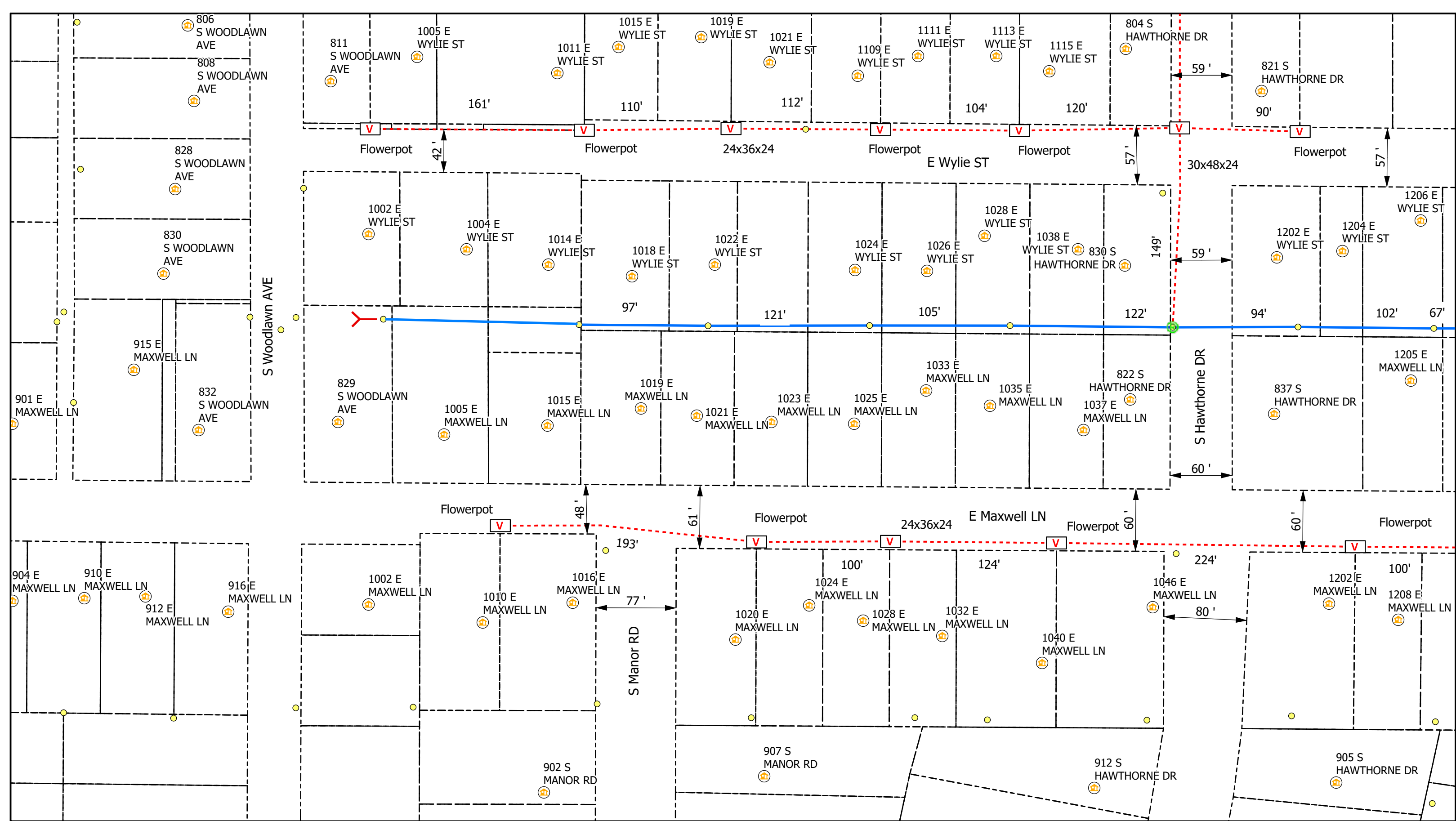

**Legend**

- Poles
- V Vaults
- Overhead Strand
- Conduit
- Bloomington\_Parcels
- R Risers
- Ⓜ Address
- Y Anchor
- ← Sidewalk
- Grids

All Flowerpots 12" DIA



City of Bloomington, IN Permit:  
Design View

INI	BY	DATE	DESCRIPTION



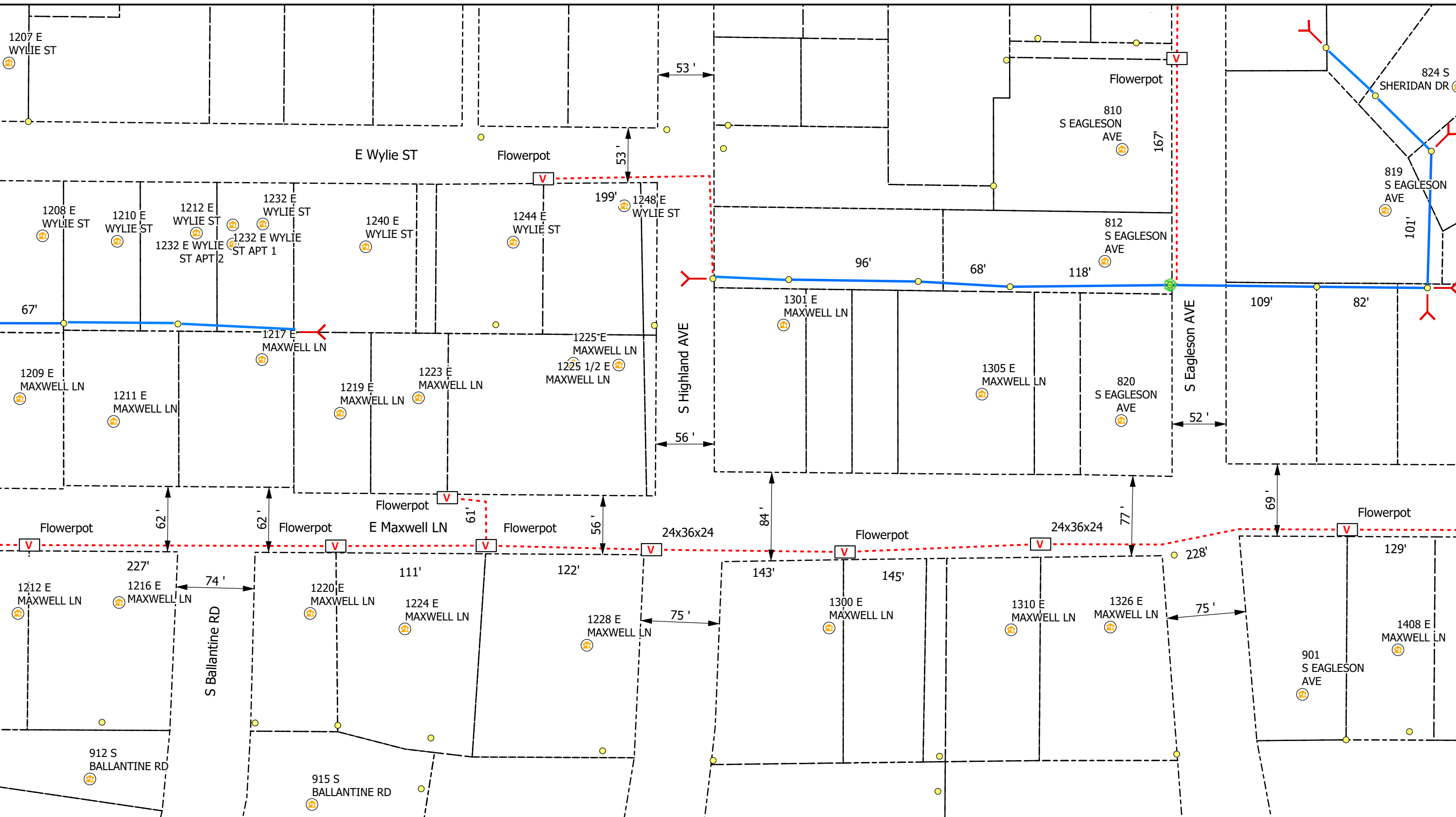

0 20 40 80 Feet

**Legend**

- Poles
- Vaults
- Overhead Strand
- Conduit
- Bloomington\_Parcels
- Risers
- Address
- Grids
- Anchor
- Sidewalk

All Flowerpots 12" DIA



City of Bloomington, IN Permit:  
Design View

INI	BY	DATE	DESCRIPTION





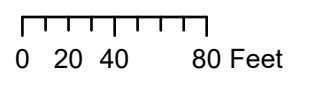
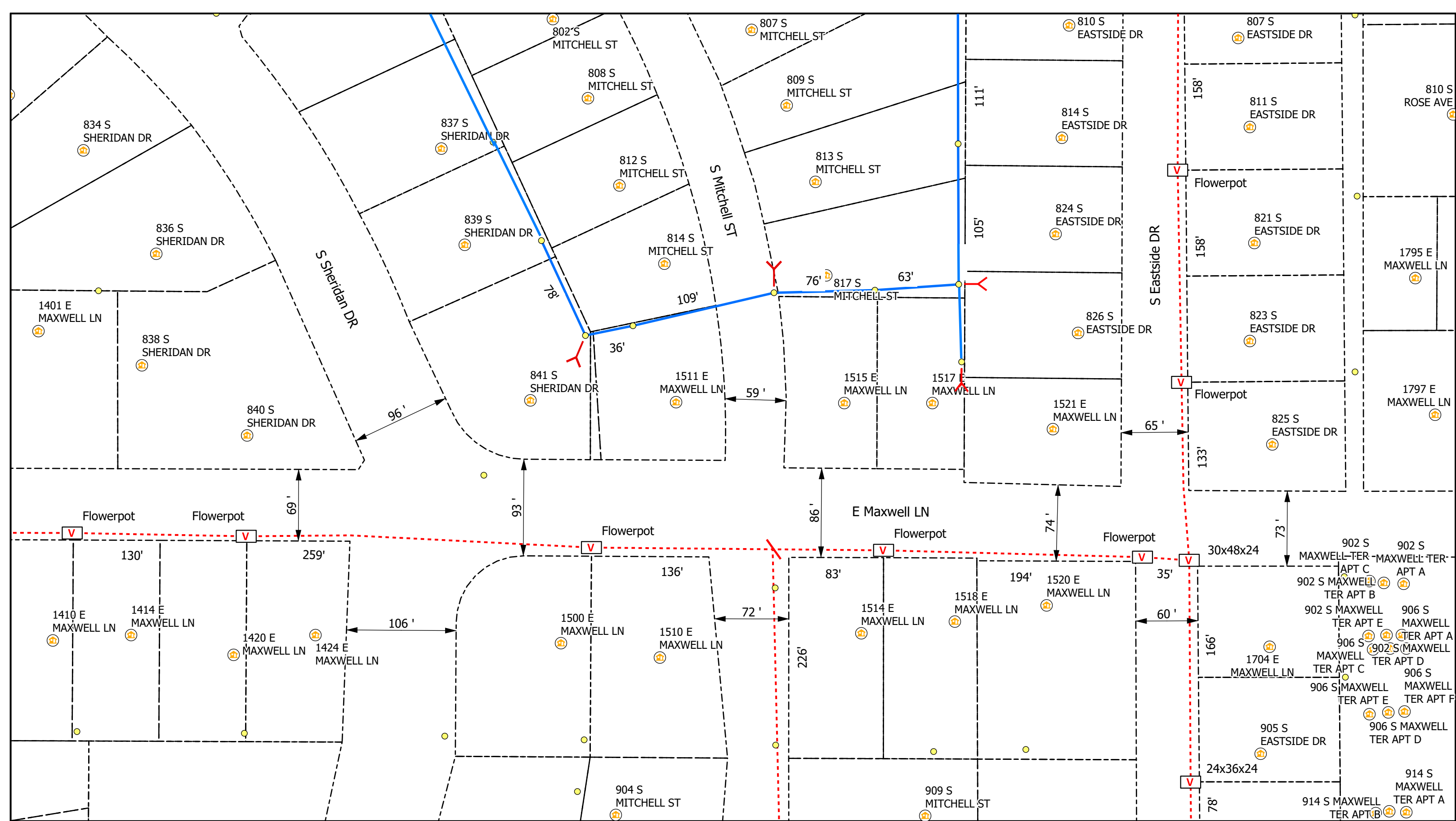

**Legend**

- Poles
- Vaults
- Overhead Strand
- Conduit
- Bloomington\_Parcels
- Risers
- Address
- Anchor
- Sidewalk
- Grids

All Flowerpots 12" DIA



City of Bloomington, IN Permit:  
Design View

INI	BY	DATE	DESCRIPTION





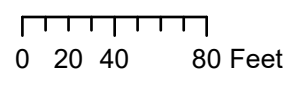

**Legend**

- Poles
- V Vaults
- Overhead Strand
- Conduit
- Bloomington\_Parcels
- R Risers
- A Address
- Y Anchor
- ← Sidewalk
- Grids

All Flowerpots 12" DIA



City of Bloomington, IN Permit:  
Design View

INI	BY	DATE	DESCRIPTION



# Carlton® PV-Mold® Nonmetallic Pole Riser System

Carlton PV-Mold is a nonmetallic pole riser system designed to protect communications power cable installed on poles.

## Features:

- Meets or exceeds requirements outlined in the National Electric Safety Code (NESC).
- Designed in accordance with NEMA TC-19 specifications.
- Ultraviolet, cold temperature and corrosive atmosphere resistant.
- Schedule 40 wall meets Schedule 80 PVC conduit impact requirements per NEMA TC-19.
- No grounding required.
- Belled end fits over each added section or conduit.
- Flame retardant.
- Requires no maintenance.
- PV-Mold acts as an insulator against electrical shock.
- Interchangeable parts and accessories to match the needs of specific requirements.



Steel U-Guard requires grounding strapping and does not have belled ends.



PV-Mold has belled ends, flanged design and does not require grounding.

## Flanged Overall Length 10 Feet, Including Bell

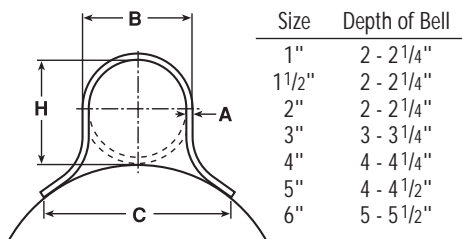

Slots are 1/2" from side to side, and allow for expansion and contraction.

Slot Dimensions: for sizes 2" through 6" are 5/16" wide, 3/4" long.

Slot Dimensions: for 1" and 1 1/2" are 3/16" wide, 3/4" long.

Slot Spacing: 18" from center, beginning 6" from end.

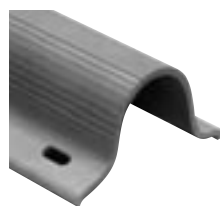

## Standard Duty

Part No.	Size	Std. Ctn. Qty.	Std. Ctn. Wt. (lbs.)	Dimensions				Actual Impact @ 0°C 20 Pound Top
				A	B	C	H	
59208N	1"	294	1059	0.100"	1 5/8"	2 3/8"	1 5/8"	40 Ft.-Lbs.
59211N	2"	136	726	0.100"	2 3/8"	4 1/2"	2 3/8"	100 Ft.-Lbs.
59211X (5' length)	2"	136	363	0.100"	2 3/8"	4 1/2"	2 3/8"	100 Ft.-Lbs.
59213N	3"	66	761	0.150"	3 1/2"	6"	3 1/2"	110 Ft.-Lbs.
59213X (5' length)	3"	66	381	0.150"	3 1/2"	6"	3 1/2"	100 Ft.-Lbs.
59215N	4"	65	910	0.150"	4 1/2"	6 1/2"	4 1/2"	110 Ft.-Lbs.
59216N	5"	30	515	0.150"	5 1/2"	7 1/2"	5 1/2"	110 Ft.-Lbs.

## Heavy Duty Schedule 40

59010N	1 1/2"	200	1142	0.145"	1 29/32"	3 1/2"	1 29/32"	100 Ft.-Lbs.
59011N	2"	136	1214	0.154"	2 3/8"	4 1/2"	2 3/8"	150 Ft.-Lbs.
59013N	3"	66	937	0.216"	3 1/2"	6"	3 9/32"	150 Ft.-Lbs.
59015N	4"	65	1621	0.237"	4 1/2"	6 1/2"	4 1/2"	260 Ft.-Lbs.
59015X (5' length)	4"	65	707	0.237"	4 1/2"	6 1/2"	4 1/2"	260 Ft.-Lbs.
59016N	5"	30	870	0.258"	5 1/2"	7 1/2"	5 1/2"	260 Ft.-Lbs.
59017N	6"	30	1160	0.280"	6 5/8"	8 3/4"	6 5/8"	260 Ft.-Lbs.

## Extra Heavy Duty Schedule 80

59411N	2"	136	1549	0.218"	2 3/8"	4 1/2"	2 3/8"	300 Ft.-Lbs.
59413N	3"	66	1495	0.030"	3 1/2"	6"	3 1/2"	525 Ft.-Lbs.

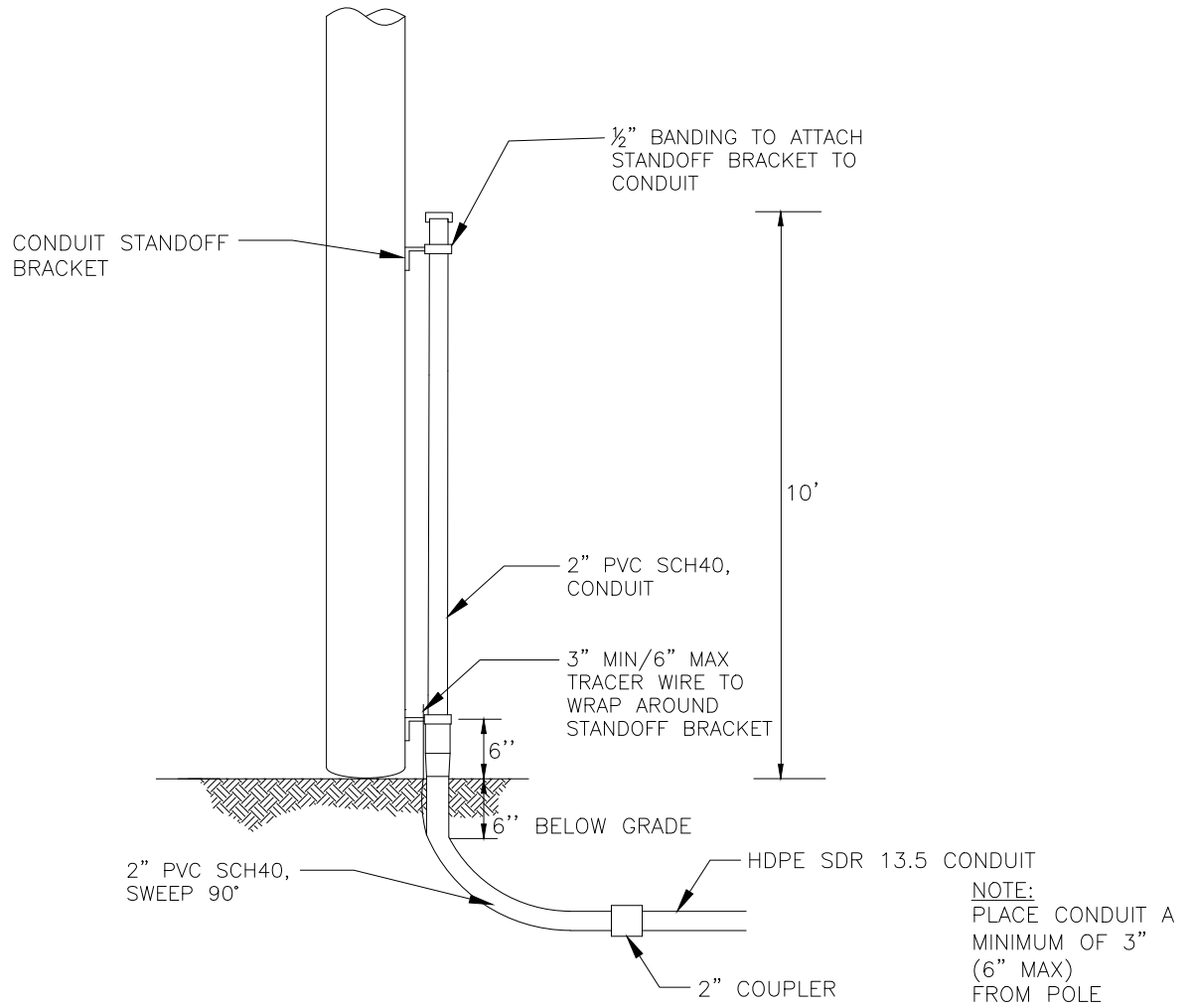

DESCRIPTION	QTY	MANUFACTURER (PREFERRED)	PART #
SCREW, LAG, 1/2" x 4-1/2"	10		
HDPE SDR 13.5 CONDUIT, VARIOUS SIZES	N/A		
2" PVC SCH40, RISER PIPE	1		
#12 TRACER WIRE	N/A		
2" PVC SCH40, SWEEP, 90 DEG	1		
CONDUIT STANDOFF BRACKET	VARIES		
CONDUIT STRAP KIT	VARIES		
2" COUPLER	1		



TYPICAL RISER  
CONDUIT  
WOOD POLE

(R2-W)

# CONCEPTUAL SIDE VIEW

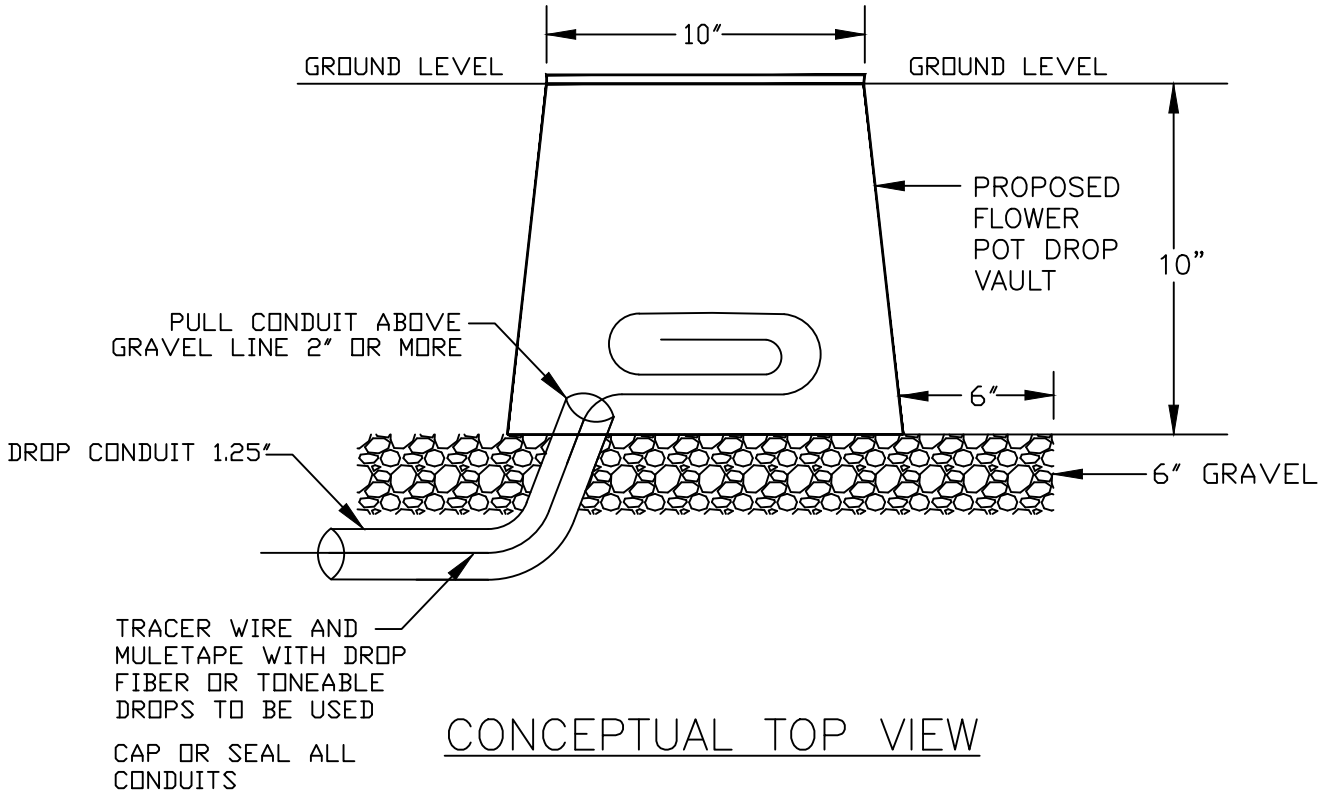

# CONCEPTUAL TOP VIEW

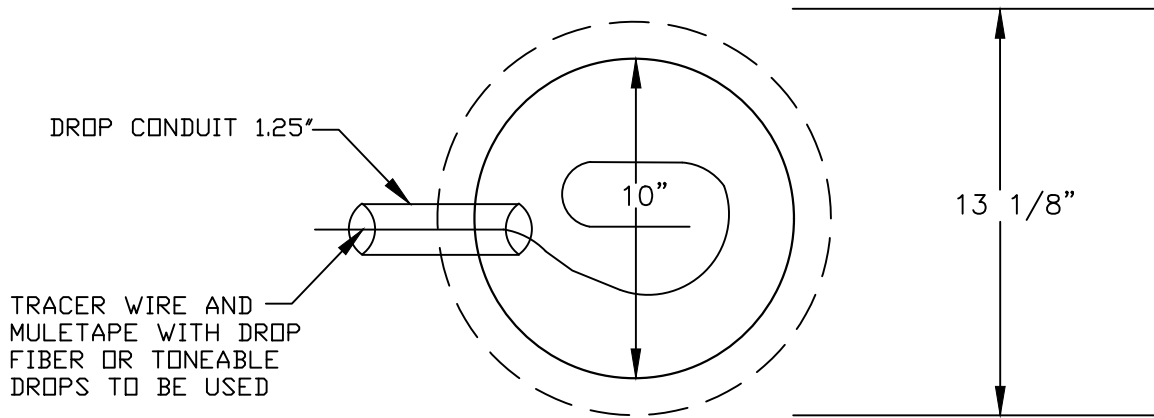

FLOWER POT

30"x48" PC UNIT, 2PC TIER 15/22  
 18", 24", and 36" HEIGHT



AMERICAN POLYMER COMPANY

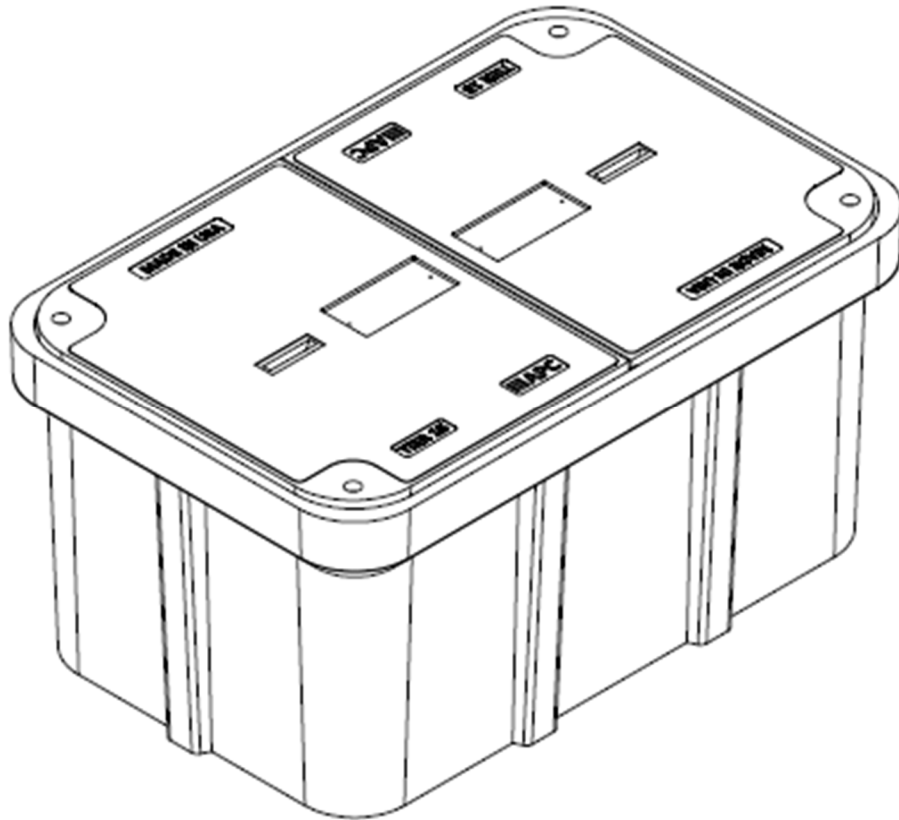

Description	Nominal Size	ANSI Tier	Part Number	Estimated Weight
PC Unit – TIER 15	30"x48"x18"	Tier 15	P304818HU15...	460 lbs.
PC Unit – TIER 22	30"x48"x18"	Tier 22	P304818HU22...	525 lbs.
PC Unit – TIER 15	30"x48"x24"	Tier 15	P304824HU15...	510 lbs.
PC Unit – TIER 22	30"x48"x24"	Tier 22	P304824HU22...	575 lbs.
PC Unit – TIER 15	30"x48"x36"	Tier 15	P304836HU15...	615 lbs.
PC Unit – TIER 22	30"x48"x36"	Tier 22	P304836HU22...	680 lbs.



# 30"x48" PC UNIT, 2PC TIER 15/22

18", 24", and 36" HEIGHT



AMERICAN POLYMER COMPANY

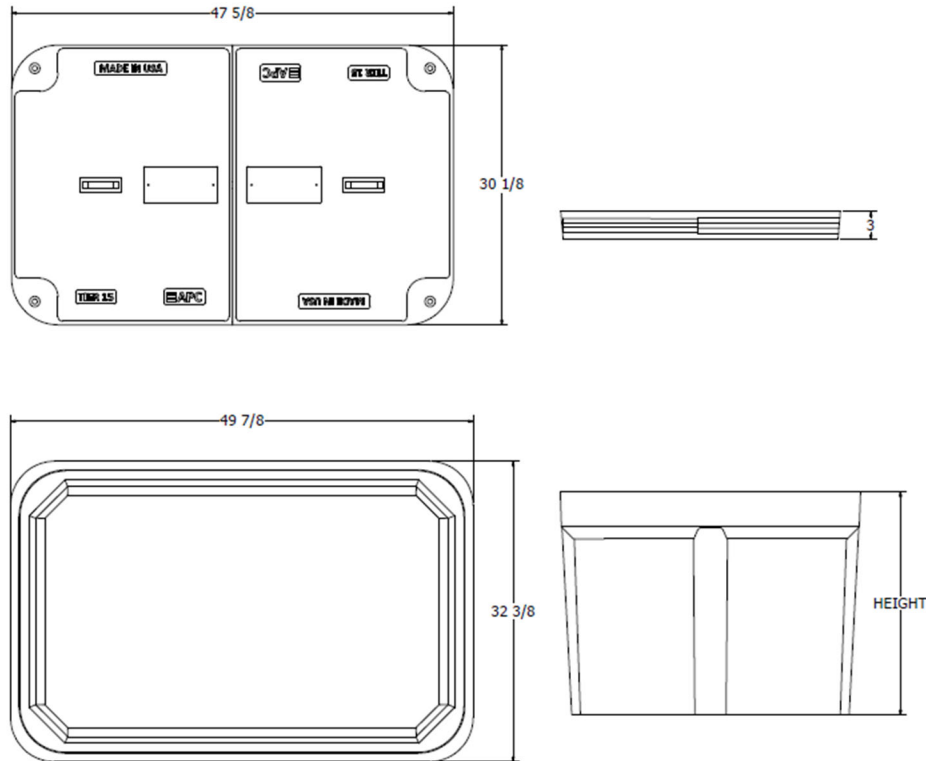

Components	Nominal Size	ANSI Tier	Part Number	Estimated Weight
Replacement Box	30"x48"x18"	Tier 22	P304818B22	185 lbs.
Replacement Box	30"x48"x24"	Tier 22	P304824B22	235 lbs.
Replacement Box	30"x48"x36"	Tier 22	P304836B22	340 lbs.
Replacement Lids - T15	30"x48" (half)	Tier 15	Various	150 lbs.
Replacement Lids - T22	30"x48" (half)	Tier 22	Various	170 lbs.

### Bolt options



Machine Thread



Auger Thread





24"x36" PC UNIT, TIER 15/22  
 18", 24", 30", and 36" HEIGHT



AMERICAN POLYMER COMPANY

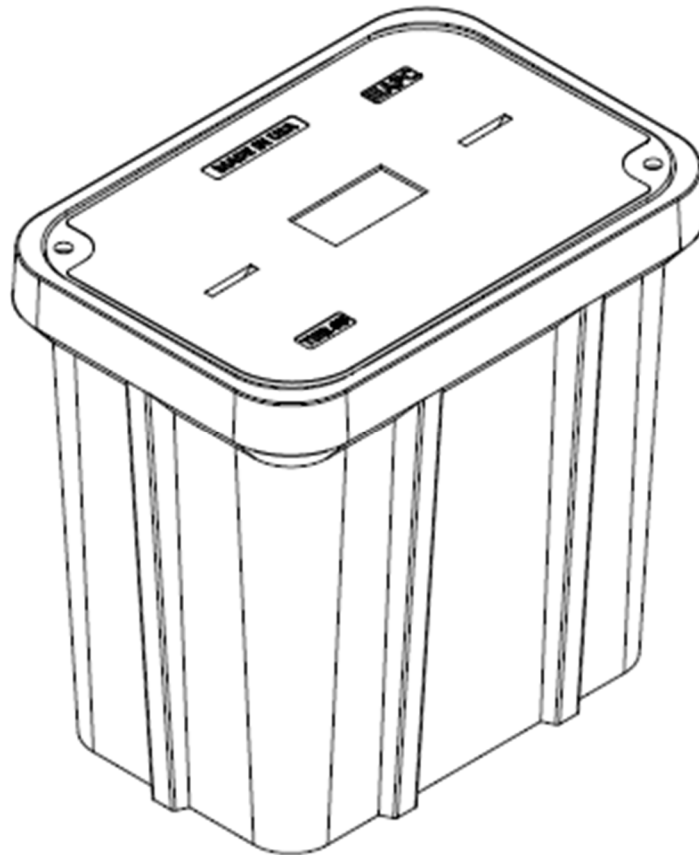

Description	Nominal Size	ANSI Tier	Part Number	Estimated Weight
PC Unit – TIER 15	24x36"x18"	Tier 15	P243618U15...	335 lbs.
PC Unit – TIER 22	24x36"x18"	Tier 22	P243618U22...	355 lbs.
PC Unit – TIER 15	24x36"x24"	Tier 15	P243624U15...	365 lbs.
PC Unit – TIER 22	24x36"x24"	Tier 22	P243624U22...	385 lbs.
PC Unit – TIER 15	24x36"x30"	Tier 15	P243630U15...	395 lbs.
PC Unit – TIER 22	24x36"x30"	Tier 22	P243630U22...	415 lbs.
PC Unit – TIER 15	24x36"x36"	Tier 15	P243636U15...	425 lbs.
PC Unit – TIER 22	24x36"x36"	Tier 22	P243636U22...	445 lbs.



# 24"x36" PC UNIT, TIER 15/22

18", 24", 30", and 36" HEIGHT



AMERICAN POLYMER COMPANY

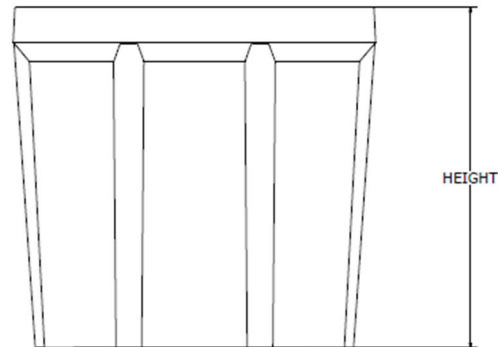
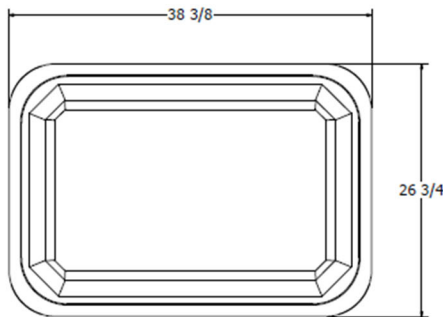
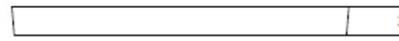
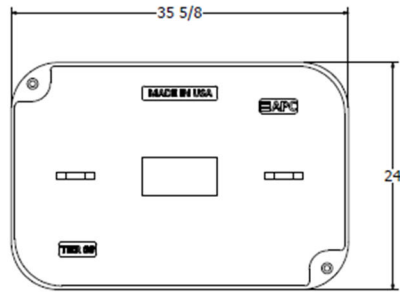

Components	Nominal Size	ANSI Tier	Part Number	Estimated Weight
Replacement Box	24"x36"x18"	Tier 22	P243618B22	165 lbs.
Replacement Box	24"x36"x24"	Tier 22	P243624B22	195 lbs.
Replacement Box	24"x36"x30"	Tier 22	P243630B22	225 lbs.
Replacement Box	24"x36"x36"	Tier 22	P243636B22	255 lbs.
Replacement Lids - T15	24"x36"	Tier 15	Various	170 lbs.
Replacement Lids - T22	24"x36"	Tier 22	Various	190 lbs.

### Bolt options

Hex Head



Machine Thread



Penta Head



Auger Thread



17"x30" PC UNIT, TIER 15/22

12", 18", 24", and 30" HEIGHT



AMERICAN POLYMER COMPANY

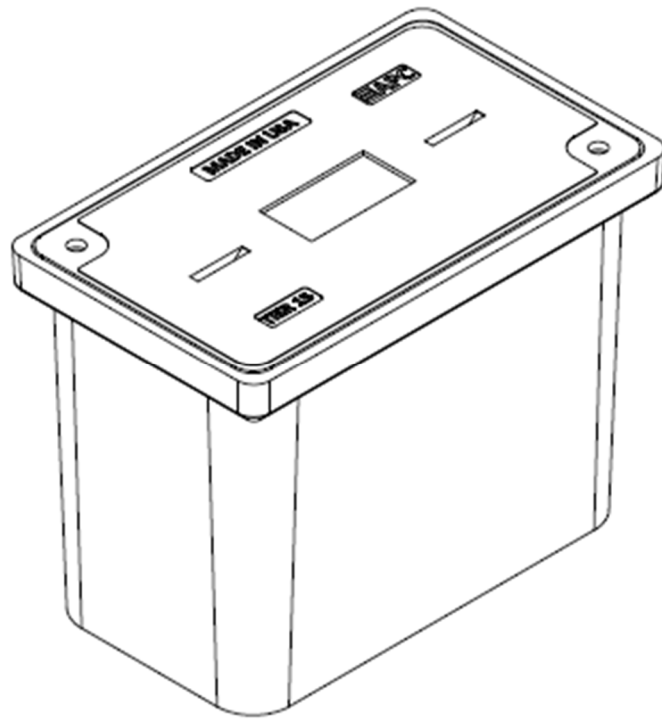

Description	Nominal Size	ANSI Tier	Part Number	Estimated Weight
PC Unit – TIER 15	17"x30"x12"	Tier 15	P173012U15...	138 lbs.
PC Unit – TIER 22	17"x30"x12"	Tier 22	P173012U22...	147 lbs.
PC Unit – TIER 15	17"x30"x18"	Tier 15	P173018U15...	172 lbs.
PC Unit – TIER 22	17"x30"x18"	Tier 22	P173018U22...	181 lbs.
PC Unit – TIER 15	17"x30"x24"	Tier 15	P173024U15...	192 lbs.
PC Unit – TIER 22	17"x30"x24"	Tier 22	P173024U22...	201 lbs.
PC Unit – TIER 15	17"x30"x30"	Tier 15	P173030U15...	217 lbs.
PC Unit – TIER 22	17"x30"x30"	Tier 22	P173030U22...	226 lbs.



# 17"x30" PC UNIT, TIER 15/22

12", 18", 24", and 30" HEIGHT



AMERICAN POLYMER COMPANY

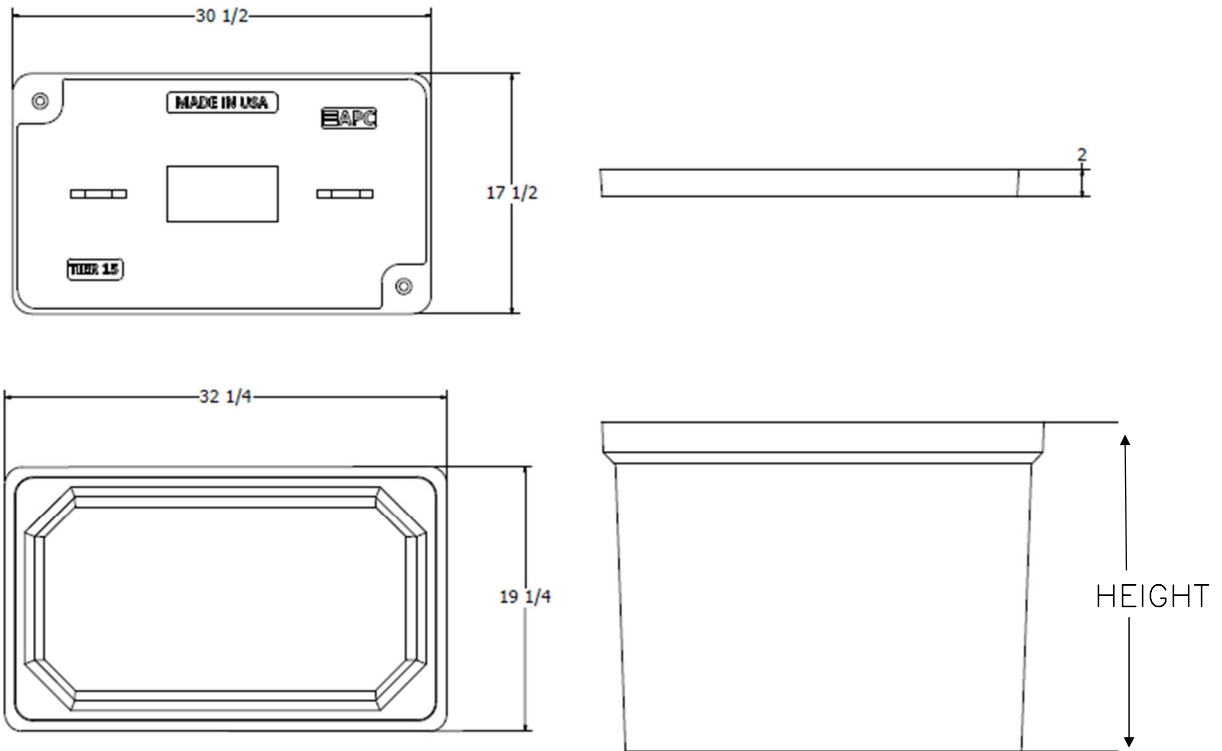

Components	Nominal Size	ANSI Tier	Part Number	Estimated Weight
Replacement Box	17"x30"x12"	Tier 22	P173012B22	66 lbs.
Replacement Box	17"x30"x18"	Tier 22	P173018B22	100 lbs.
Replacement Box	17"x30"x24"	Tier 22	P173024B22	120 lbs.
Replacement Box	17"x30"x30"	Tier 22	P173030B22	145 lbs.
Replacement Lids – T15	17"x30"	Tier 15	Various	72 lbs.
Replacement Lids – T22	17"x30"	Tier 22	Various	81 lbs.

### Bolt options



Machine Thread



Auger Thread



33"x60" PC UNIT, 2PC TIER 15/22  
36" HEIGHT



AMERICAN POLYMER COMPANY

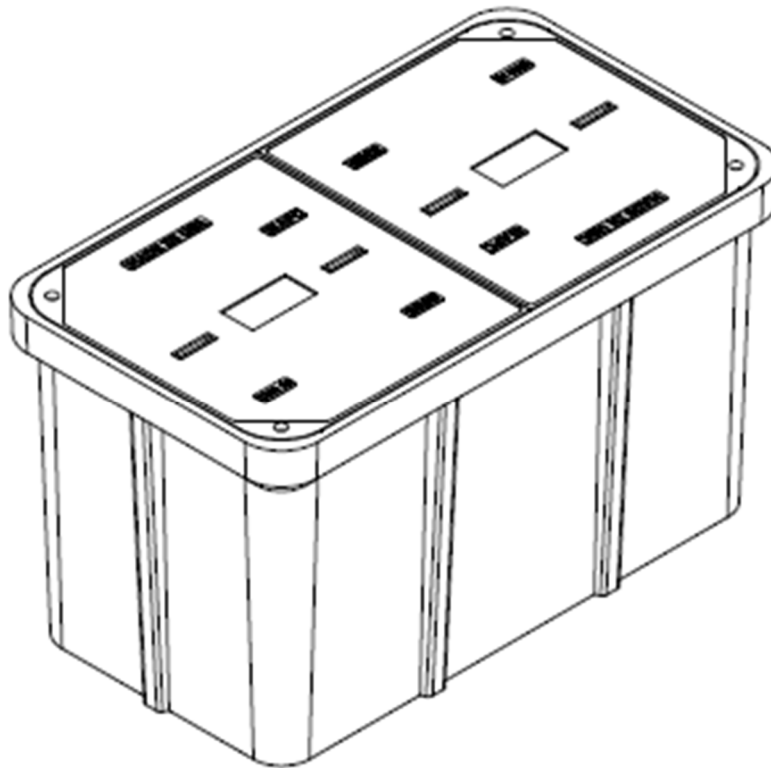

Description	Nominal Size	ANSI Tier	Part Number	Estimated Weight
PC Unit - TIER 15	33"x60"x36"	Tier 15	P336036U15...	930 lbs.
PC Unit - TIER 22	33"x60"x36"	Tier 22	P336036U22...	1030 lbs.



# 33"x60" PC UNIT, 2PC TIER 15/22

## 36" HEIGHT



AMERICAN POLYMER COMPANY

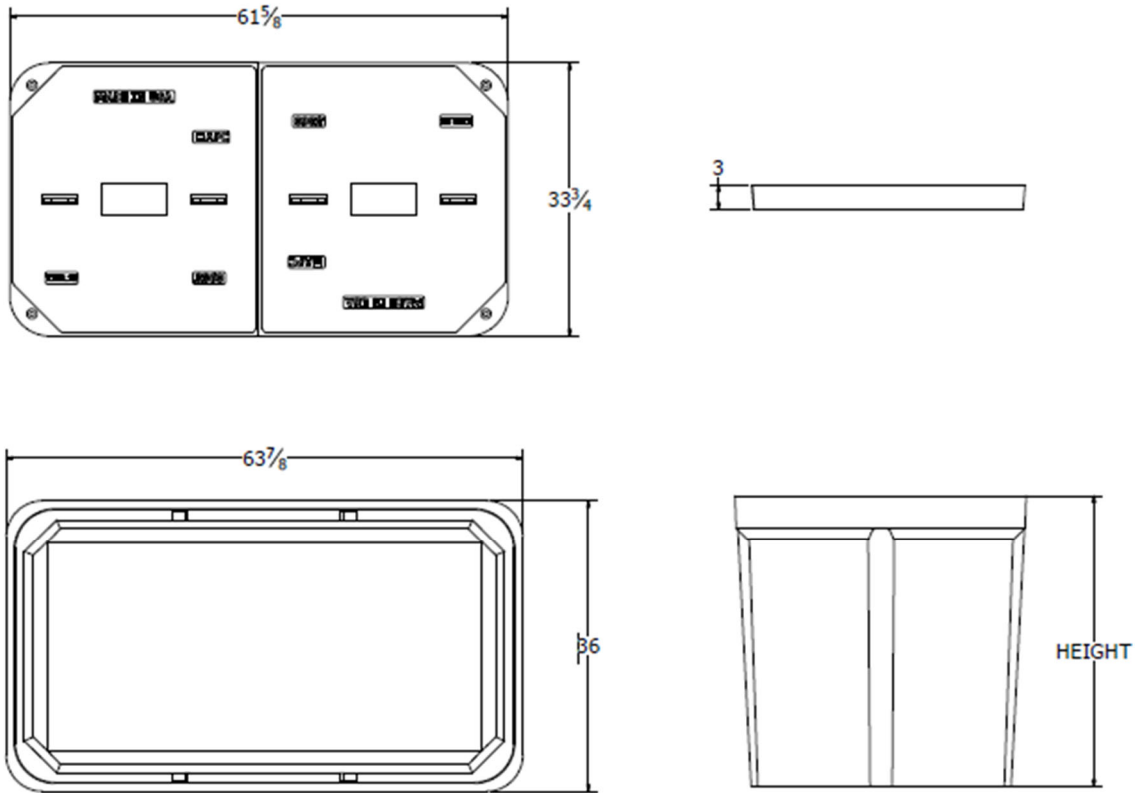

Components	Nominal Size	ANSI Tier	Part Number	Estimated Weight
Replacement Box	33"x60"x36"	Tier 22	P336036B22	530 lbs.
Replacement Lids - T15	33"x60" (half)	Tier 15	Various	200 lbs.
Replacement Lids - T22	33"x60" (half)	Tier 22	Various	250 lbs.

### Bolt options

Hex Head



Machine Thread



Penta Head



Auger Thread





Spacing Charts Based on MUTCD			Must be Approved by an Engineer				
Speed (MPH) Prior To Road Work	SIGN SPACING, FT.		BUFFER SPACE, FT.	TAPER LENGTH, FT.	CHANNELIZING SPACING, FT.		
	Non-Divided Highways	Divided Highways	Length	Shoulder (10 ft. Width)	Lane (12 ft. Width)	Through Taper	Through Buffer/Work Area
0-35	200	200	250	70	245	35	50
40-45	350	500	360	150	540	40	80
50-55	500	1000	495	185	660	50	100
60-70	SA-1000, SB-1500, SC-2640		730	235	840	60	120
Urban Low Speed - 100 FT							

APPROVED/ACCEPTED BY:  
ENGINEER, OWNER, or PRIME CONTRACTOR  
 Check for Notice to Proceed.  
**BLC01b-F14 - E University St - TCP1**

Signature: \_\_\_\_\_

Company: \_\_\_\_\_



Date: 2/10/2023 Project: BLC01b-F14 - E University St - TCP1 :  
: Traffic Control Suggestion For: AEG :  
By: Road Runner Safety Services, Inc. : Nathan

Comments:  
Drawing not to scale. Traffic control plan must be approved by an engineer. This is a suggestion only. Road Runners Safety Services, Inc. has no liability for this suggested traffic control plan. Actual placement and spacing of all traffic control devices will depend on field conditions and must conform to MUTCD standards.

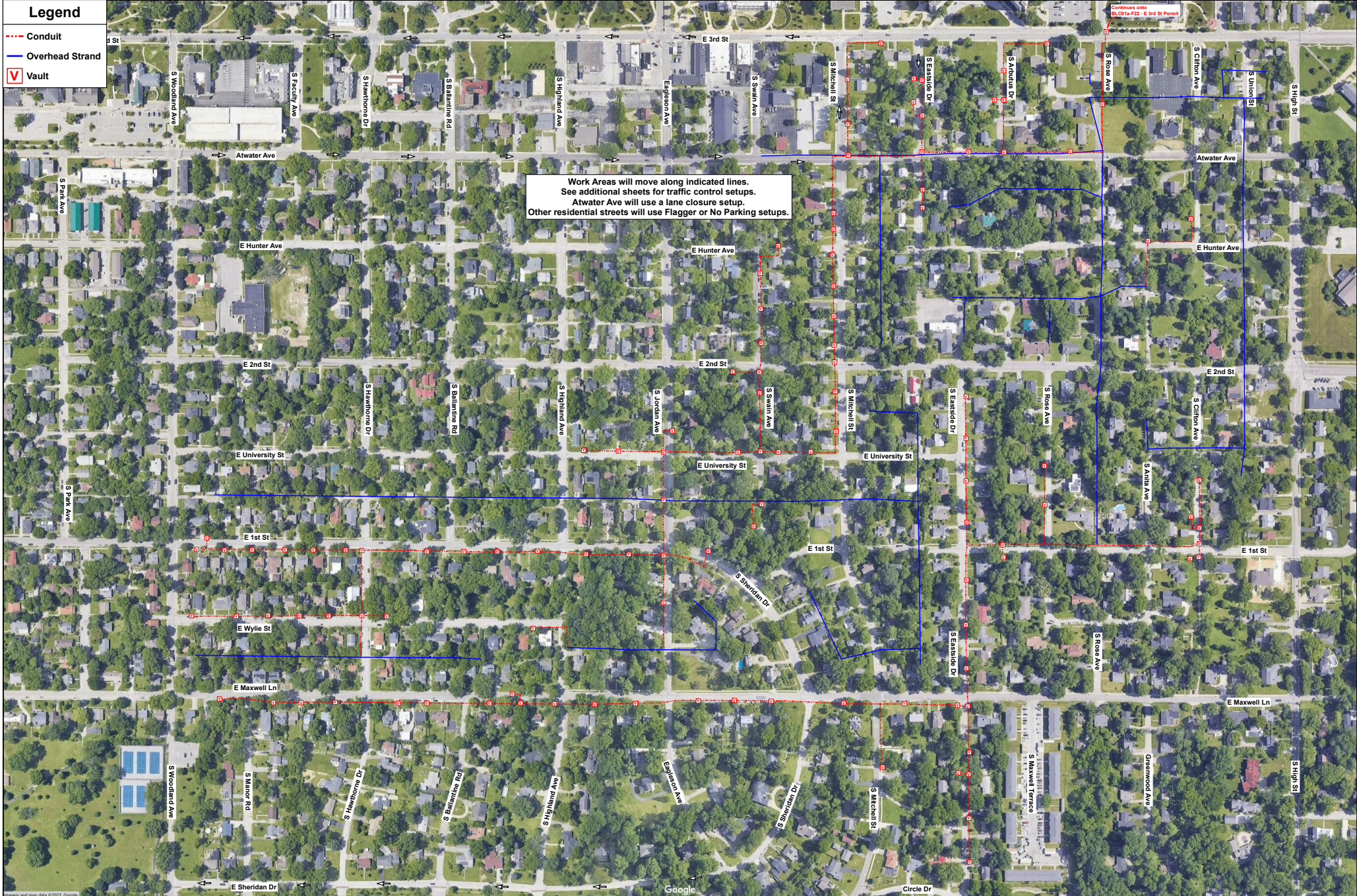







# CITY OF BLOOMINGTON RIGHT-OF-WAY USE PERMIT APPLICATION

401 N Morton Street, Suite 130  
P.O. Box 100  
Bloomington, IN 47402

Phone: (812) 349-3913  
Fax: (812) 349-3520  
Email:  
engineering@bloomington.in.gov

ROW EXCAVATION  ROW USE

ADDRESS OF ROW ACTIVITY: E University St

<b>A. APPLICANT/AGENT INFORMATION:</b>		<b>D. TRAFFIC CONTROL DEVICES*:</b>	
APPLICANT NAME: <u>Bret Simons</u>		<input checked="" type="checkbox"/> CONES <input type="checkbox"/> ARROWBOARD	
E-MAIL: <u>bret.simons@aeg.cc</u>		<input type="checkbox"/> LIGHTED BARRELS <input checked="" type="checkbox"/> TYPE 3 BARRICADES	
COMPANY: <u>Atlantic Engineering Group</u>		<input checked="" type="checkbox"/> FLAGGERS <input type="checkbox"/> BPD OFFICER	
ADDRESS: <u>P.O. Box 349</u>		*PROVIDING MUTCD COMPLIANT TEMPORARY TRAFFIC CONTROL DEVICES AND MAINTENANCE OF TRAFFIC (MOT) PLAN IS YOUR RESPONSIBILITY AND REQUIRED. See page 3 for additional MOT resources; the graph paper can be used for your MOT site plan if needed or you can submit a separate sheet	
CITY, STATE, ZIP: <u>Buford, GA 30515</u>			
24-HR EMERGENCY CONTACT NAME: <u>(706)654-2298</u>		<b>E. METERED PARKING SPACES NEEDED: <input type="checkbox"/> Y <input type="checkbox"/> N</b>	
24-HR CONTACT PHONE #: _____		IT IS THE RESPONSIBILITY OF THE APPLICANT TO RESERVE PARKING METER(S) APPLICATION LOCATED: <a href="https://bloomington.in.gov/transportation/parking/moving">https://bloomington.in.gov/transportation/parking/moving</a> OR CONTACT PARKING SERVICES WITH QUESTIONS AT (812)349-3436	
INSURANCE #*: <u>TB5-691-473497-082</u> COMPANY: <u>ACORD</u>		<b>F. IS THIS A <input type="checkbox"/> CBU* <input type="checkbox"/> COUNTY* <input type="checkbox"/> IU* <input type="checkbox"/> NP* PROJECT?</b>	
BOND #*: <u>1160465</u> COMPANY: <u>LEXON</u>		PROJECT NAME: <u>BLC01b-F14 - E University St</u>	
*INSURANCE & BOND MUST BE ON FILE WITH THE CITY BEFORE PERMIT WILL BE ISSUED		PROJECT #: <u>BLC01b-F14 - E University St</u>	
<b>**SUBCONTRACTOR INFORMATION**</b>		PROJECT MGR.: <u>Lex Mullins</u>	
(LIST ALL COMPANIES WORKING UNDER PRIMARY CONTRACTOR PERMIT)		PROJECT MGR. #: <u>215-847-8819</u>	
COMPANY NAME: _____		*CBU = CITY OF BLOOMINGTON UTILITIES *COUNTY = MONROE COUNTY	
<b>B. WORK DESCRIPTION:</b>		*IU = INDIANA UNIVERSITY *NP = NOT-FOR-PROFIT AGENCY	
<input type="checkbox"/> POD/DUMPSTER <input type="checkbox"/> CRANE <input type="checkbox"/> SCAFFOLDING <input checked="" type="checkbox"/> CONSTRUCTION USE*		<b>G. EXCAVATIONS:</b>	
(EXPLAIN): <u>Excavation</u>		SQ FT OF PAVEMENT* EXCAVATIONS : <u>N/A</u>	
*EXCAVATION, LONG TERM USE FOR STORAGE OF MATERIAL/EQUIPMENT/WALKAROUND		*PAVEMENT INCLUDES: IN OR UNDER CONCRETE, OR ASPHALT INCLUDING CURBS	
<b>C. RIGHT OF WAY TO BE USED/CLOSED:</b>		SQ FT OF NON-PAVEMENT* EXCAVATIONS: <u>303 Sq Ft</u>	
STREET NAME 1: <u>E University St</u>		*DIRT, GRASS, GRAVEL, LANDSCAPE AREA OR OTHER UNPAVED SURFACE	
1ST INTERSECTING STREET NAME: _____		LINEAL FT OF BORE*: <u>16,583 Lineal Ft</u>	
2ND INTERSECTING STREET NAME: _____		*BORE PITS SHALL BE CALCULATED AS SQ FT EXCAVATIONS	
<input type="checkbox"/> ROAD CLOSURE <input checked="" type="checkbox"/> LANE CLOSURE 1 <input checked="" type="checkbox"/> 2 <input type="checkbox"/> 3 <input type="checkbox"/>		# OF POLE INSTALLATIONS/REMOVAL: <u>N/A</u>	
<input checked="" type="checkbox"/> SIDEWALK* <input type="checkbox"/> BIKE LANE <input type="checkbox"/> OTHER		SQ FT OF SIDEWALK RECONSTRUCTION*: <u>N/A</u>	
TRANSIT STOP? <input type="checkbox"/> Y <input type="checkbox"/> N PARKING LANE(S)** <input type="checkbox"/> Y <input type="checkbox"/> N **NON-METERED		*CONCRETE OR ASPHALT SIDEWALK/PATH BEING IMPROVED/REPLACED	
START DATE: <u>Mar 3rd</u> END DATE: _____ # OF DAYS*: <u>30</u>		SQ FT OF SIDEWALK NEW CONSTRUCTION*: <u>N/A</u>	
STREET NAME 2: _____		*CONCRETE OR ASPHALT SIDEWALK/PATH THAT IS NEW INFRASTRUCTURE	
1ST INTERSECTING STREET NAME: _____		#RESIDENTIAL DRIVEWAY INSTALLATION: <u>N/A</u>	
2ND INTERSECTING STREET NAME: _____		 <p>TO SUBMIT A LOCATE REQUEST 24 HRS A DAY, 7 DAYS A WEEK CALL 811 OR 800-382-5544 CALL 2 WORKING DAYS BEFORE YOU DIG. IT'S THE LAW.</p>	
<input type="checkbox"/> ROAD CLOSURE <input type="checkbox"/> LANE CLOSURE 1 <input type="checkbox"/> 2 <input type="checkbox"/> 3 <input type="checkbox"/>			
<input type="checkbox"/> SIDEWALK* <input type="checkbox"/> BIKE LANE <input type="checkbox"/> OTHER		<b>H. INDEMNIFICATION AGREEMENT:</b>	
TRANSIT STOP? <input type="checkbox"/> Y <input type="checkbox"/> N PARKING LANE(S)** <input type="checkbox"/> Y <input type="checkbox"/> N **NON-METERED		The petitioner/applicant hereby agrees to hold harmless, defend and to indemnify the City of Bloomington from or against all claims, action, damages and expenses, including but not limited to reasonable attorney's fees or any alleged injury and/or death to any person or damage to any property arising, or alleged to have arisen out of any act of commission or omission on the part of the petitioner/applicant, his/her heirs, successors, or assigns regardless of whether such acts are the direct or indirect result of the public right-of-way use pursuant to this permit grant.	
START DATE: _____ END DATE: _____ # OF DAYS*: _____		I AFFIRM, UNDER THE PENALTIES FOR PERJURY, THAT THE FOREGOING REPRESENTATIONS ARE TRUE.	
*SIDEWALK CLOSURES FOR A PERIOD OR PERIODS TOTALING 24HRS OR MORE SHALL INSTALL A WALKAROUND UNLESS OTHERWISE APPROVED DURING REVIEW		PRINT NAME: <u>Bret Simons</u>	
<b>STANDARD CLOSURE HOURS MON-FRI*: 9:00 AM - 3:00 PM &amp; 6:00 PM - 9:00 PM</b>		SIGNATURE: <u>Bret Simons</u>	
STANDARD CLOSURE HOURS <input checked="" type="checkbox"/> *NON-STANDARD CLOSURE HOURS <input type="checkbox"/>		DATE: <u>2/10/2023</u>	
REQUESTED CLOSURE HOURS: _____ AM - _____ PM			
*non-standard hours may not be allowed near schools, on arterials, or other circumstances and are subject to approval during the permitting process			
BMC 14.09.040 allows work from 6 AM to 10 PM without violating the noise ordinance (7AM to 9PM for pneumatic hammers)			

For Administration Use Only (applicable to CLOSURE approval)

Approved By: \_\_\_\_\_  BPW  City Engineer  Director Date: \_\_\_\_\_

Staff Representative: \_\_\_\_\_ Phone#: \_\_\_\_\_ Date: \_\_\_\_\_

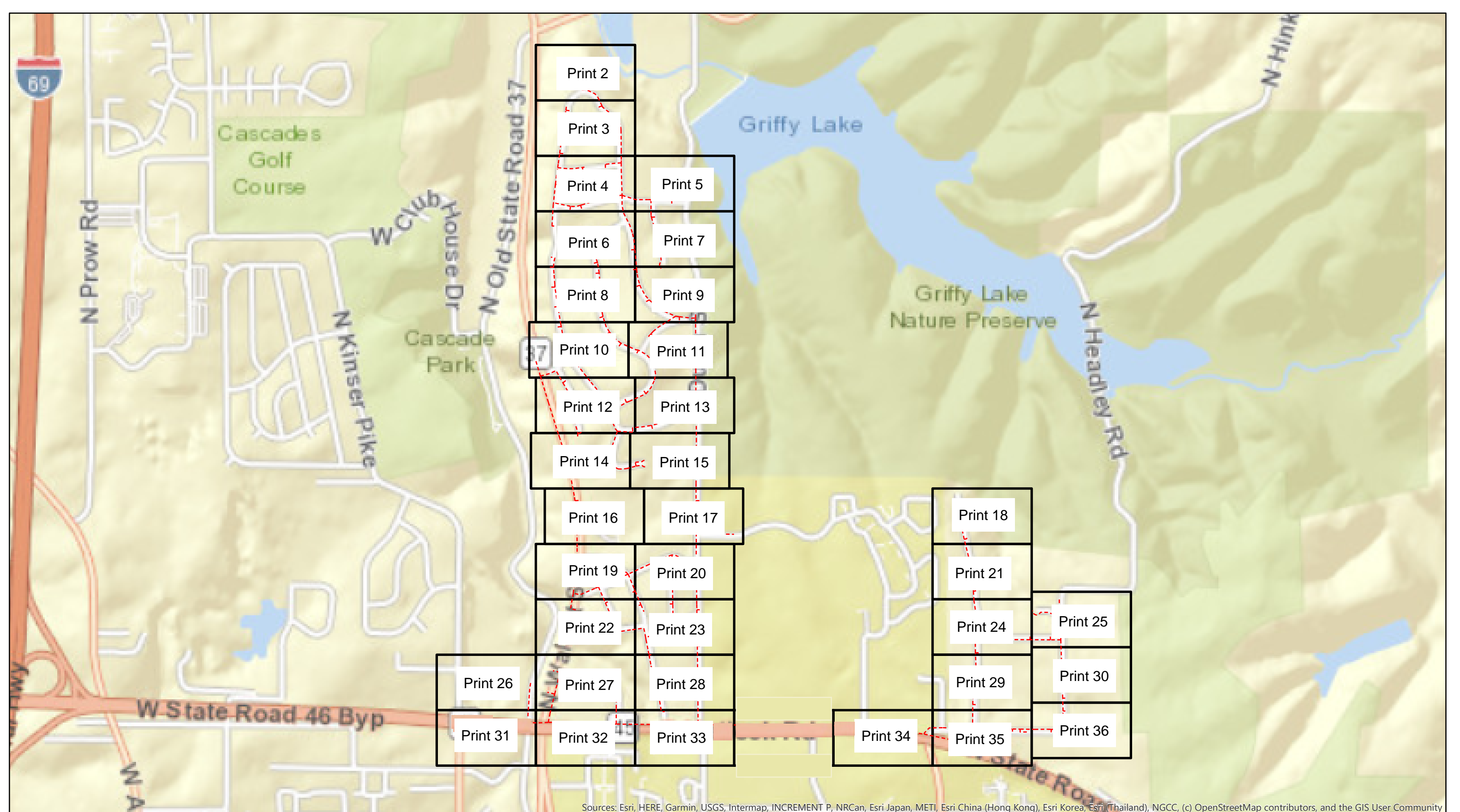

Sources: Esri, HERE, Garmin, USGS, Intermap, INCREMENT P, NRCan, Esri Japan, METI, Esri China (Hong Kong), Esri Korea, Esri (Thailand), NGCC, (c) OpenStreetMap contributors, and the GIS User Community



Legend BLN01a-F01\_E Tamarack Trl

- Overhead Strand
- - - Conduit
- Grids



City of Bloomington, IN Permit:  
Design View

INI	BY	DATE	DESCRIPTION

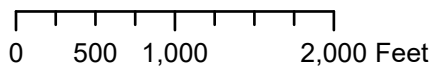

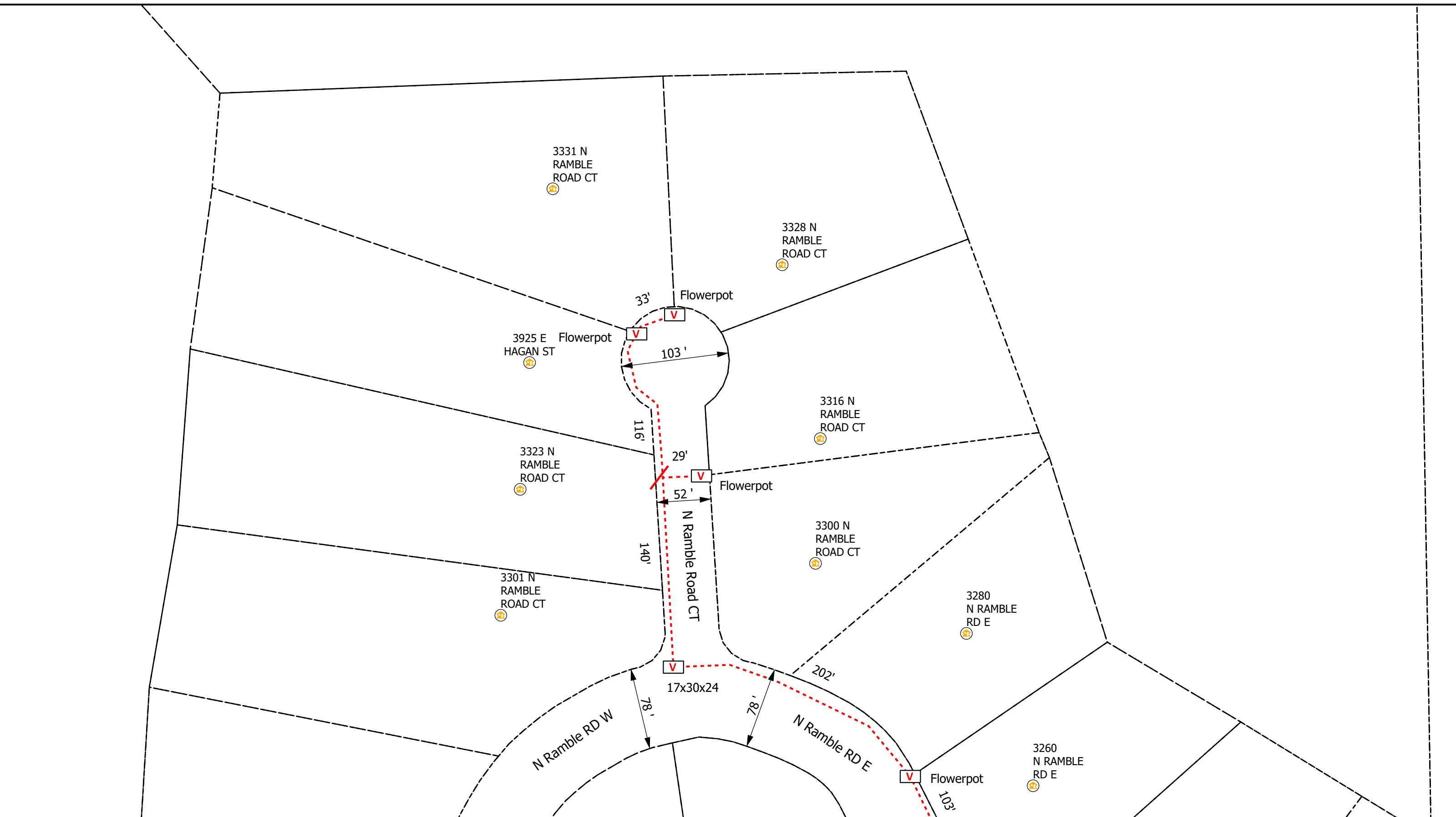

**Legend**

- Poles
- Vaults
- Overhead Strand
- Conduit
- Bloomington\_Parcels
- R Risers
- A Address
- Anchor
- Sidewalk
- Grids

All Flowerpots 12" DIA



City of Bloomington, IN Permit:  
Design View

INI	BY	DATE	DESCRIPTION



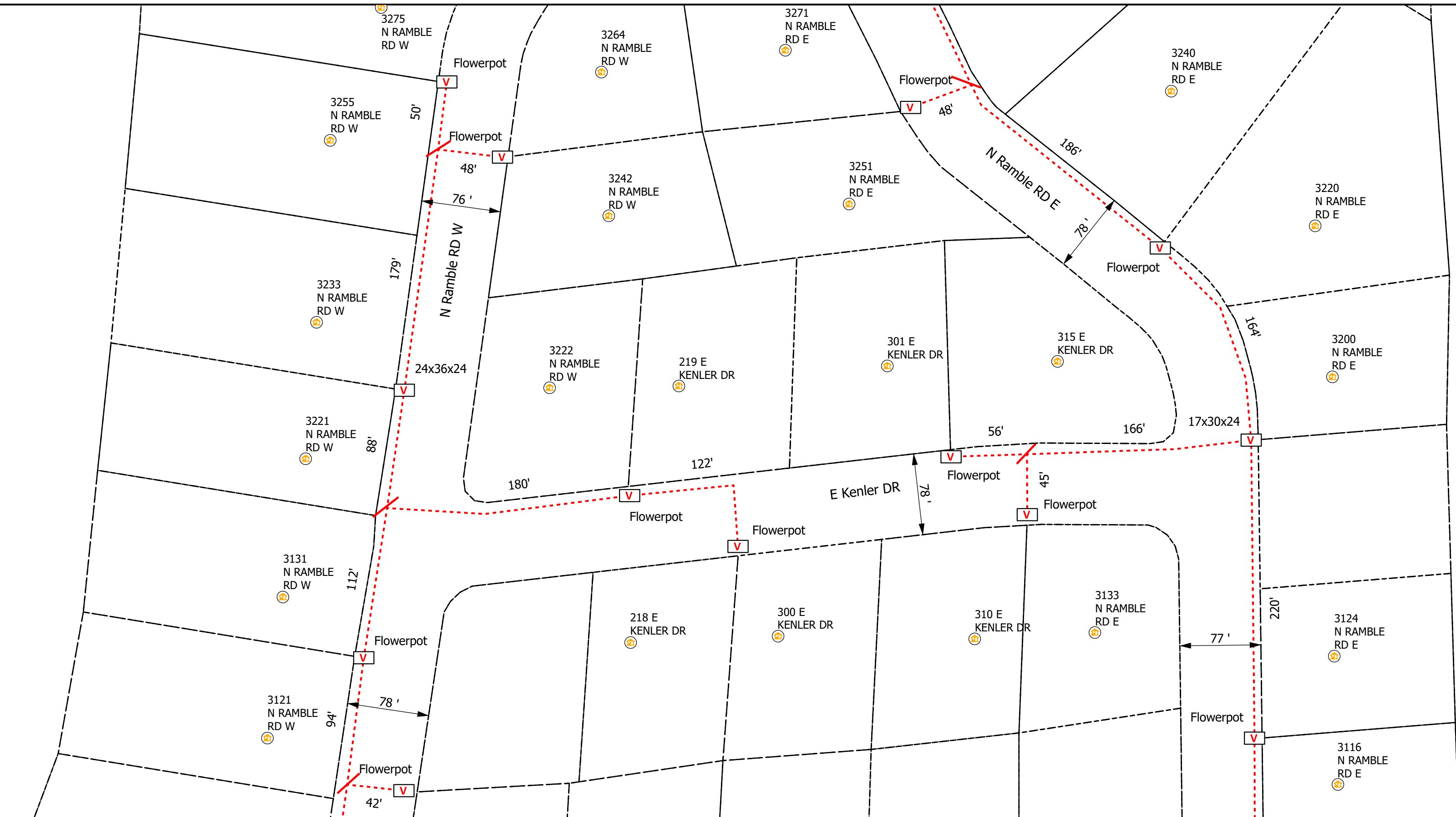

**Legend**

- Poles
- Vaults
- Overhead Strand
- Conduit
- Bloomington\_Parcels
- Risers
- Address
- Anchor
- Sidewalk
- Grids

All Flowerpots 12" DIA

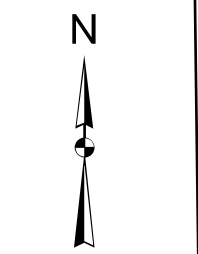

City of Bloomington, IN Permit:  
Design View

INI	BY	DATE	DESCRIPTION

Print 3 of 36



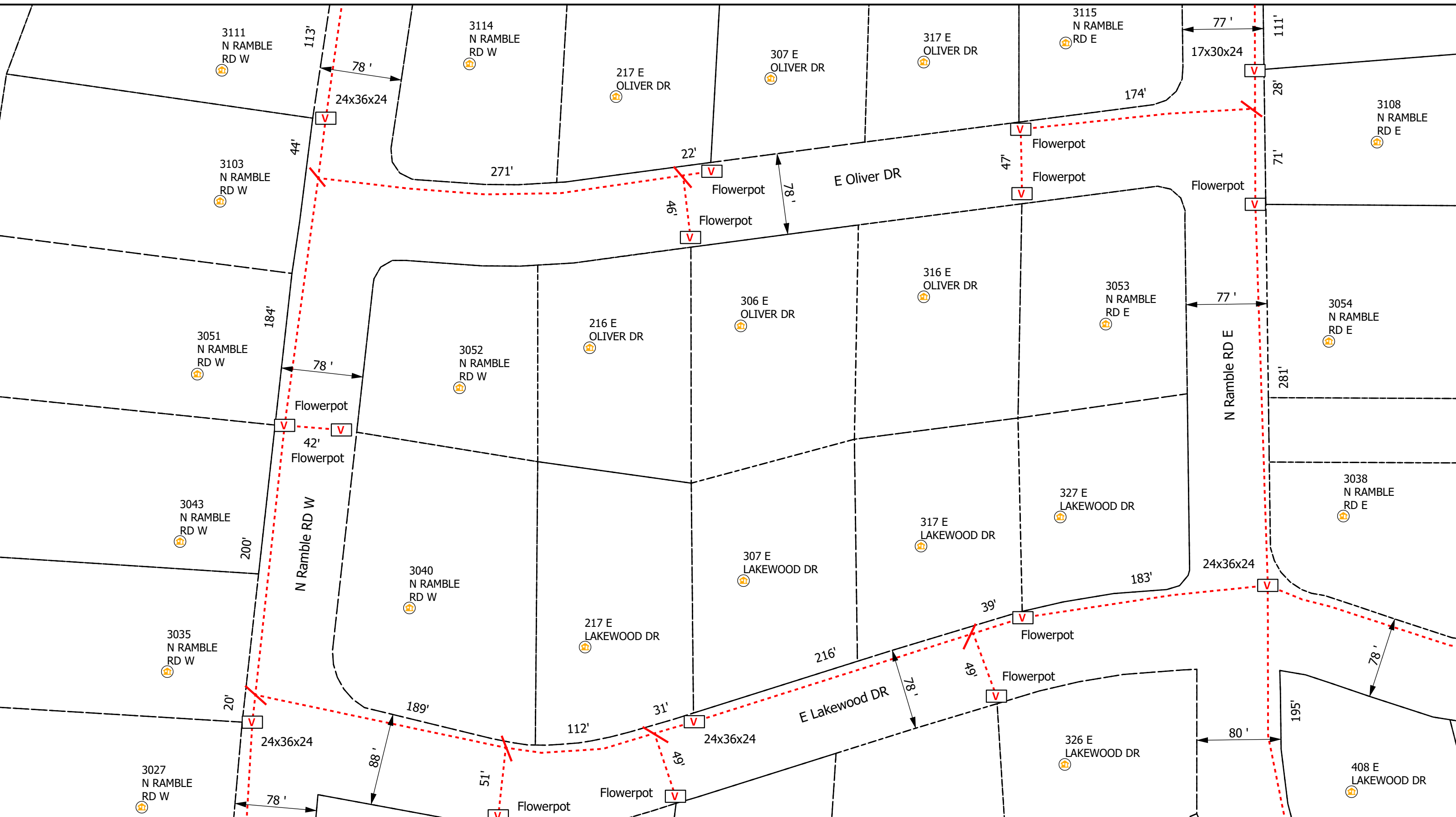

**Legend**

- Poles
- Vaults
- Overhead Strand
- Conduit
- Bloomington\_Parcels
- Risers
- Address
- Anchor
- Sidewalk
- Grids

All Flowerpots 12" DIA

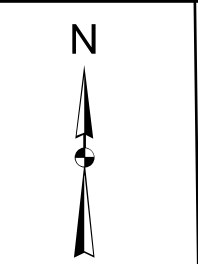

City of Bloomington, IN Permit:  
Design View

INI	BY	DATE	DESCRIPTION

Print 4 of 36

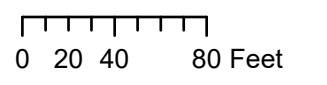
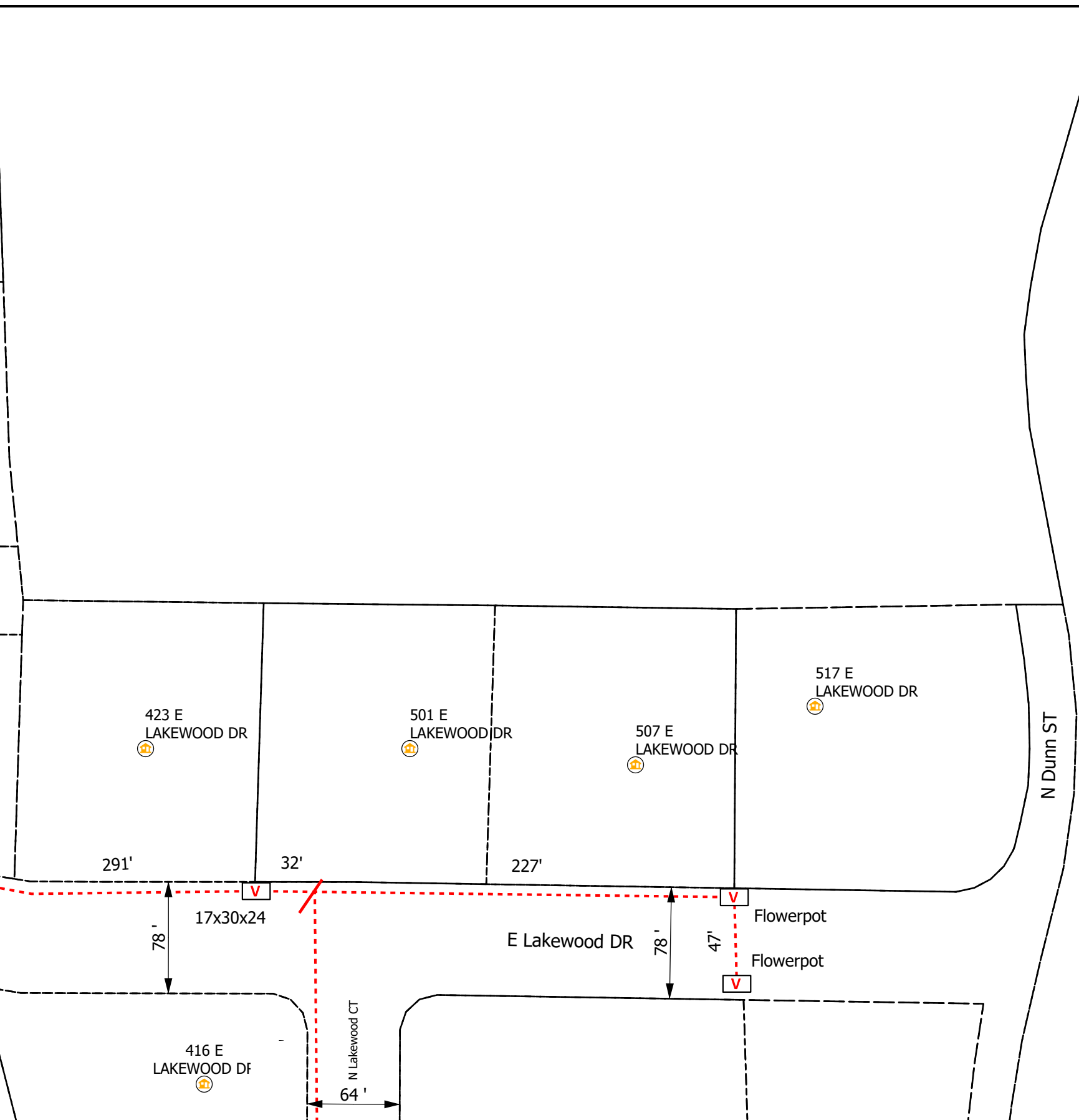

**Legend**

- Poles
- V Vaults
- Overhead Strand
- Conduit
- Bloomington\_Parcels
- R Risers
- A Address
- Y Anchor
- K Sidewalk
- Grids

All Flowerpots 12" DIA



City of Bloomington, IN Permit:  
Design View

INI	BY	DATE	DESCRIPTION



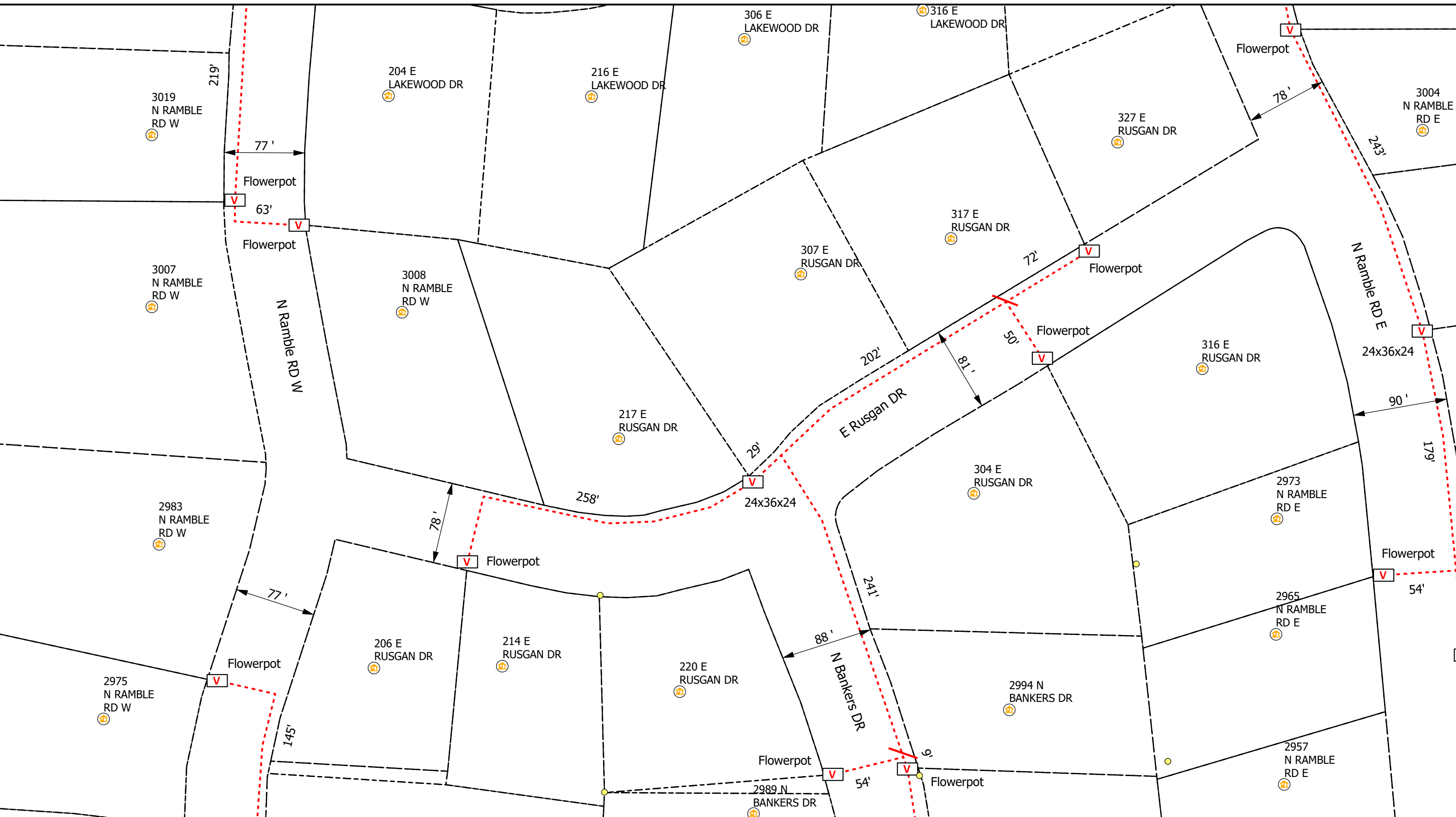

**AEG**

0 20 40 80 Feet

**Legend**

- Poles
- Ⓜ Bloomington\_Parcels
- Ⓜ Risers
- Ⓜ Address
- Ⓜ Overhead Strand
- Ⓜ Conduit
- Ⓜ Vault
- Ⓜ Anchor
- Ⓜ Sidewalk
- Ⓜ Grids

All Flowerpots 12" DIA

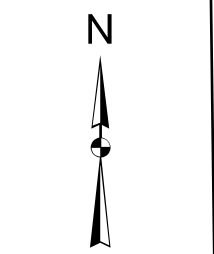

City of Bloomington, IN Permit:  
Design View

INI	BY	DATE	DESCRIPTION

Indiana 811

Print 6 of 36

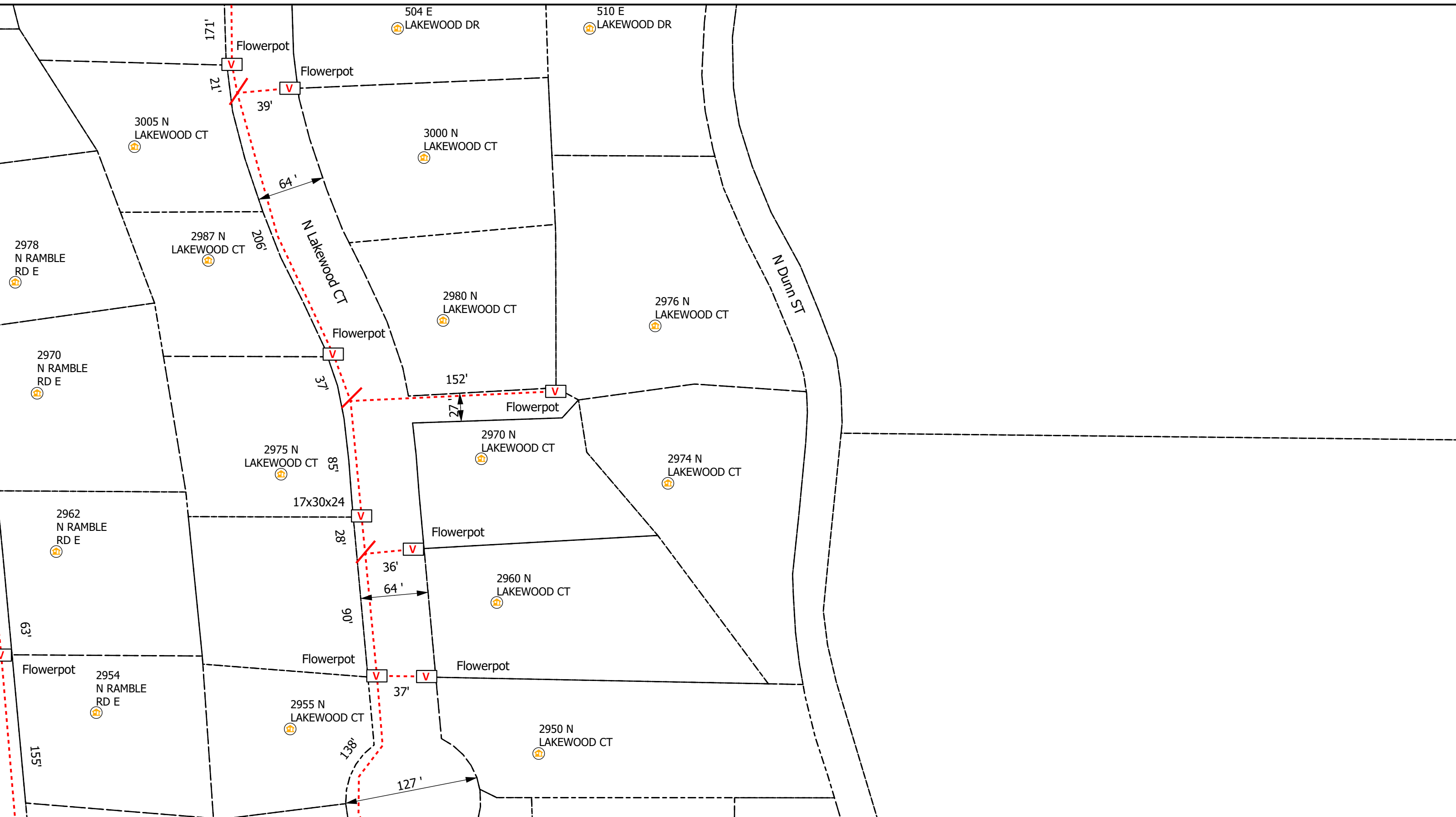

0 20 40 80 Feet

**Legend**

- Poles
- Vaults
- Overhead Strand
- Conduit
- Bloomington\_Parcels
- Risers
- Address
- Anchor
- Sidewalk
- Grids

All Flowerpots 12" DIA

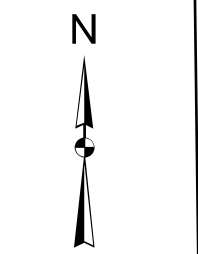

City of Bloomington, IN Permit:  
Design View

INI	BY	DATE	DESCRIPTION

Print 7 of 36

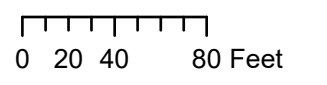
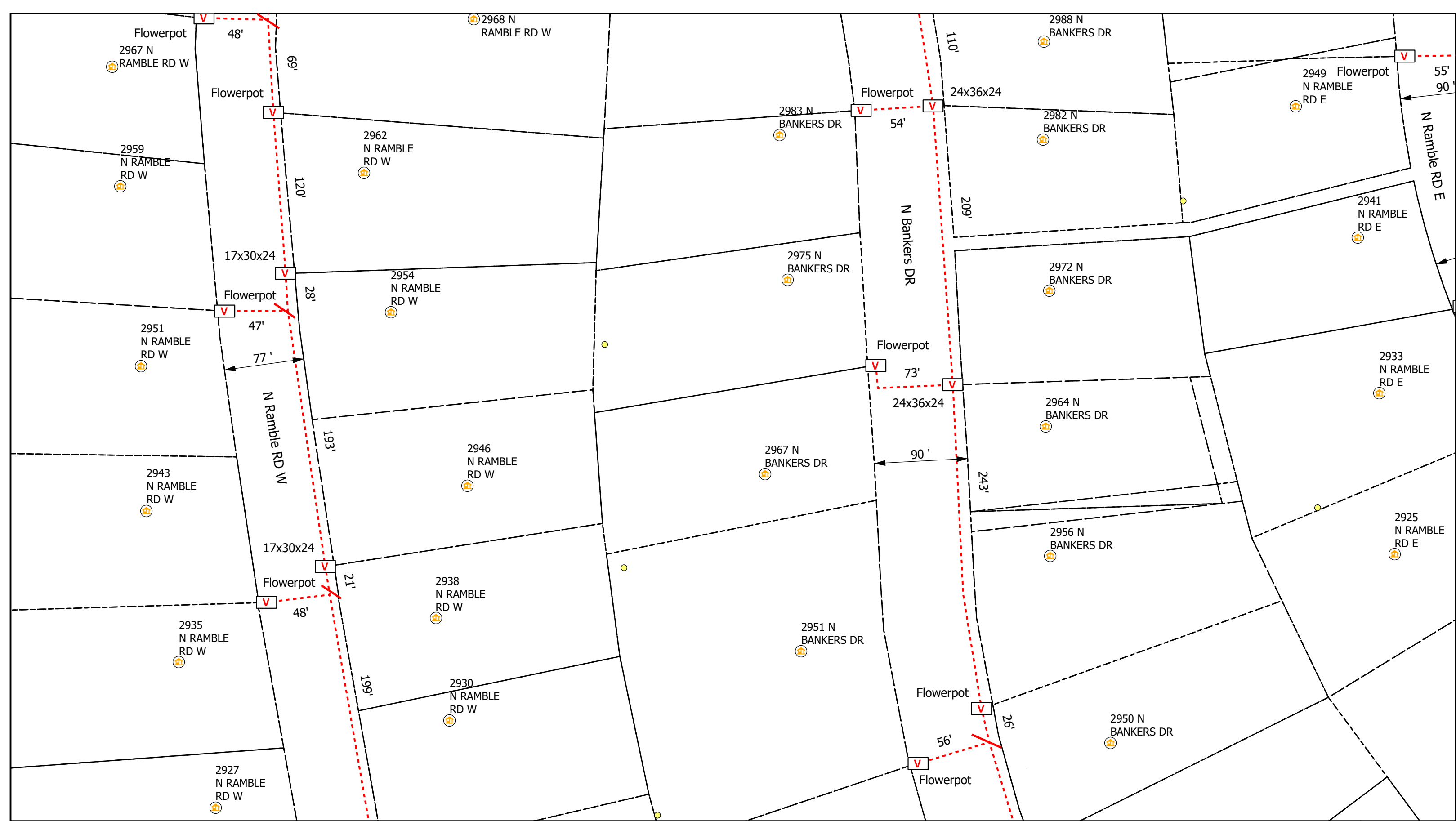

**Legend**

- Poles
- V Vaults
- Overhead Strand
- Conduit
- Bloomington\_Parcels
- R Risers
- A Address
- Y Anchor
- ← Sidewalk
- Grids

All Flowerpots 12" DIA



City of Bloomington, IN Permit:  
Design View

INI	BY	DATE	DESCRIPTION





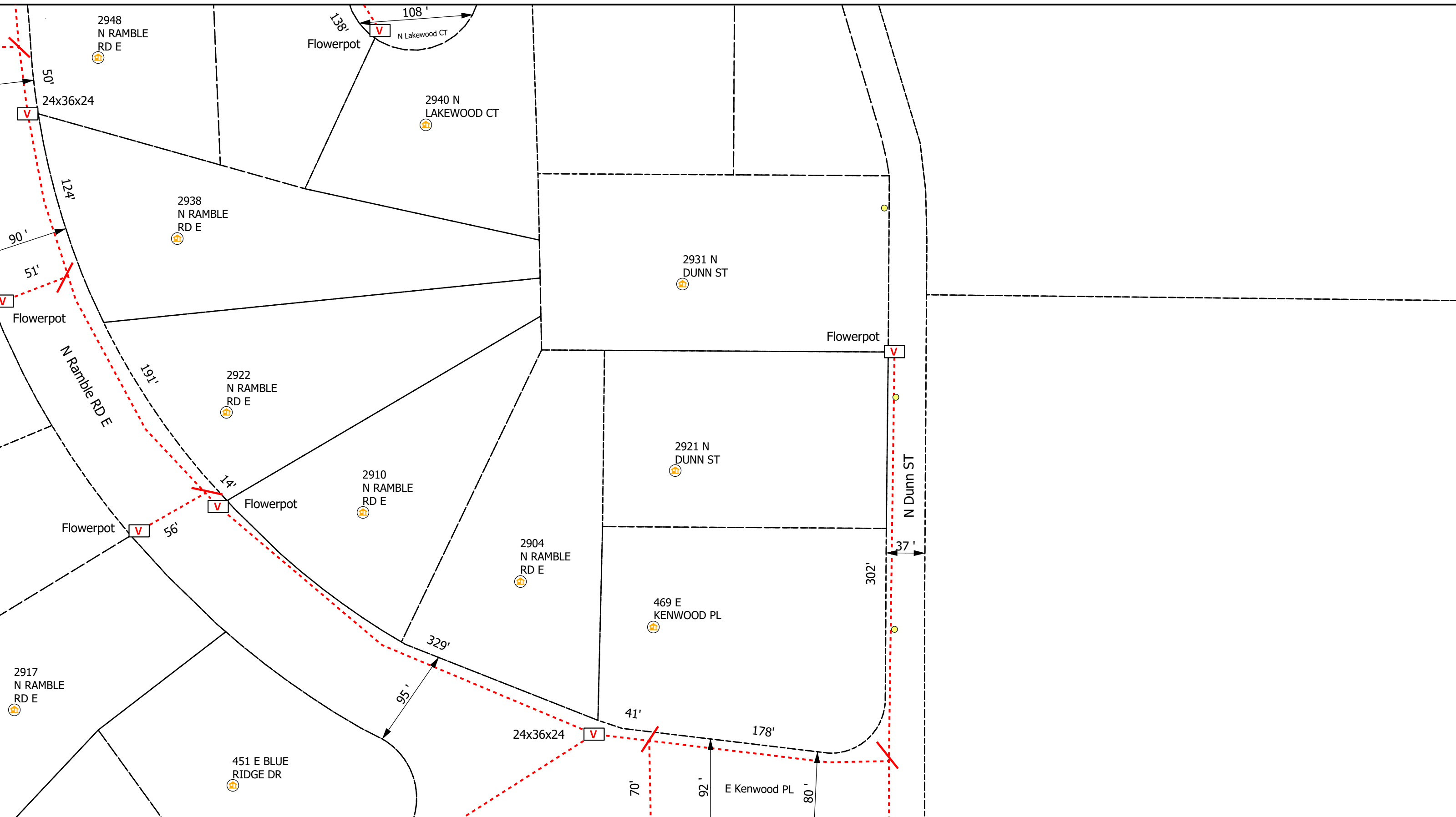

**AEG**

0 20 40 80 Feet

**Legend**

- Poles
- V Vaults
- Overhead Strand
- Conduit
- Bloomington\_Parcels Bloomington\_Parcels
- R Risers
- A Address
- Y Anchor
- ← Sidewalk
- Grids

All Flowerpots 12" DIA

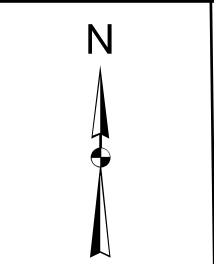

City of Bloomington, IN Permit:  
Design View

INI	BY	DATE	DESCRIPTION

Indiana 811

Print 9 of 36

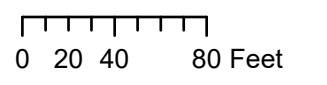
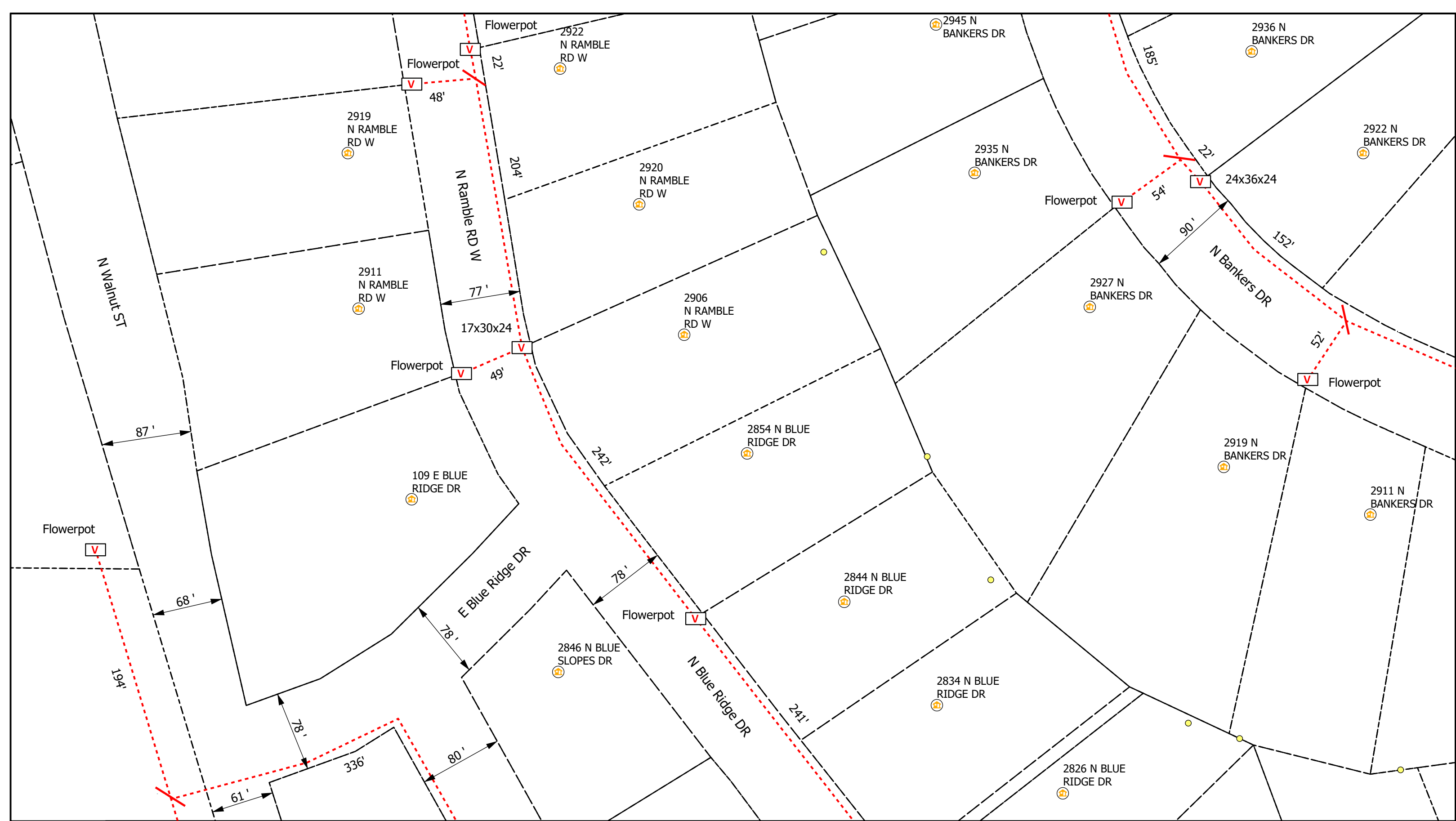

**Legend**

- Poles
- V Vaults
- Overhead Strand
- Conduit
- Bloomington\_Parcels
- R Risers
- Ⓜ Address
- Y Anchor
- ← Sidewalk
- Grids

All Flowerpots 12" DIA



City of Bloomington, IN Permit:  
Design View

INI	BY	DATE	DESCRIPTION



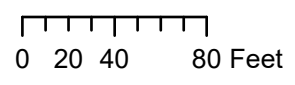
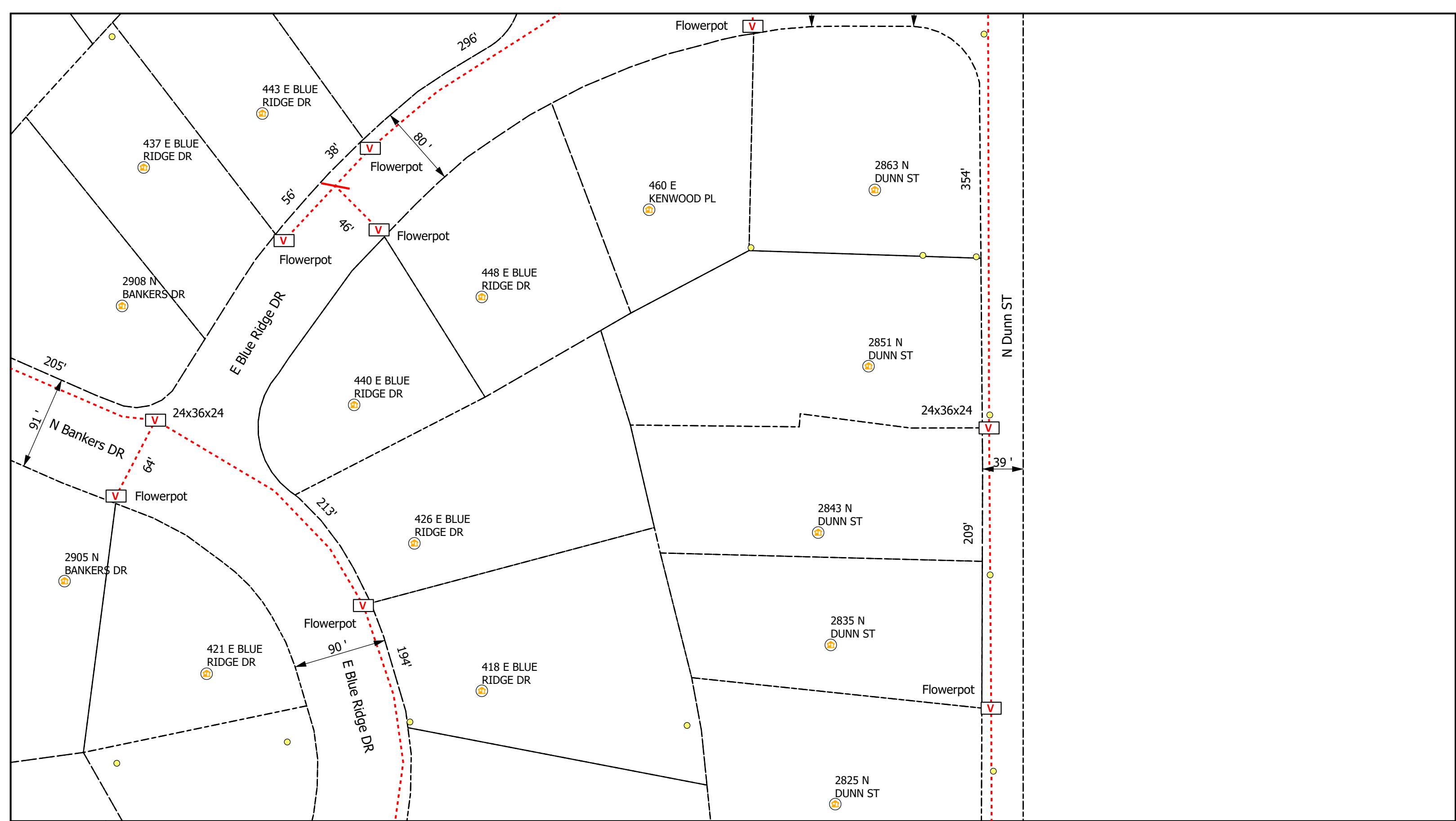

**Legend**

- Poles
- Vaults
- Overhead Strand
- Conduit
- Bloomington\_Parcels
- Risers
- Address
- Anchor
- Sidewalk
- Grids

All Flowerpots 12" DIA



City of Bloomington, IN Permit:  
Design View

INI	BY	DATE	DESCRIPTION



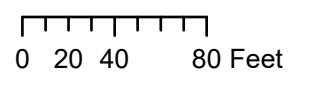
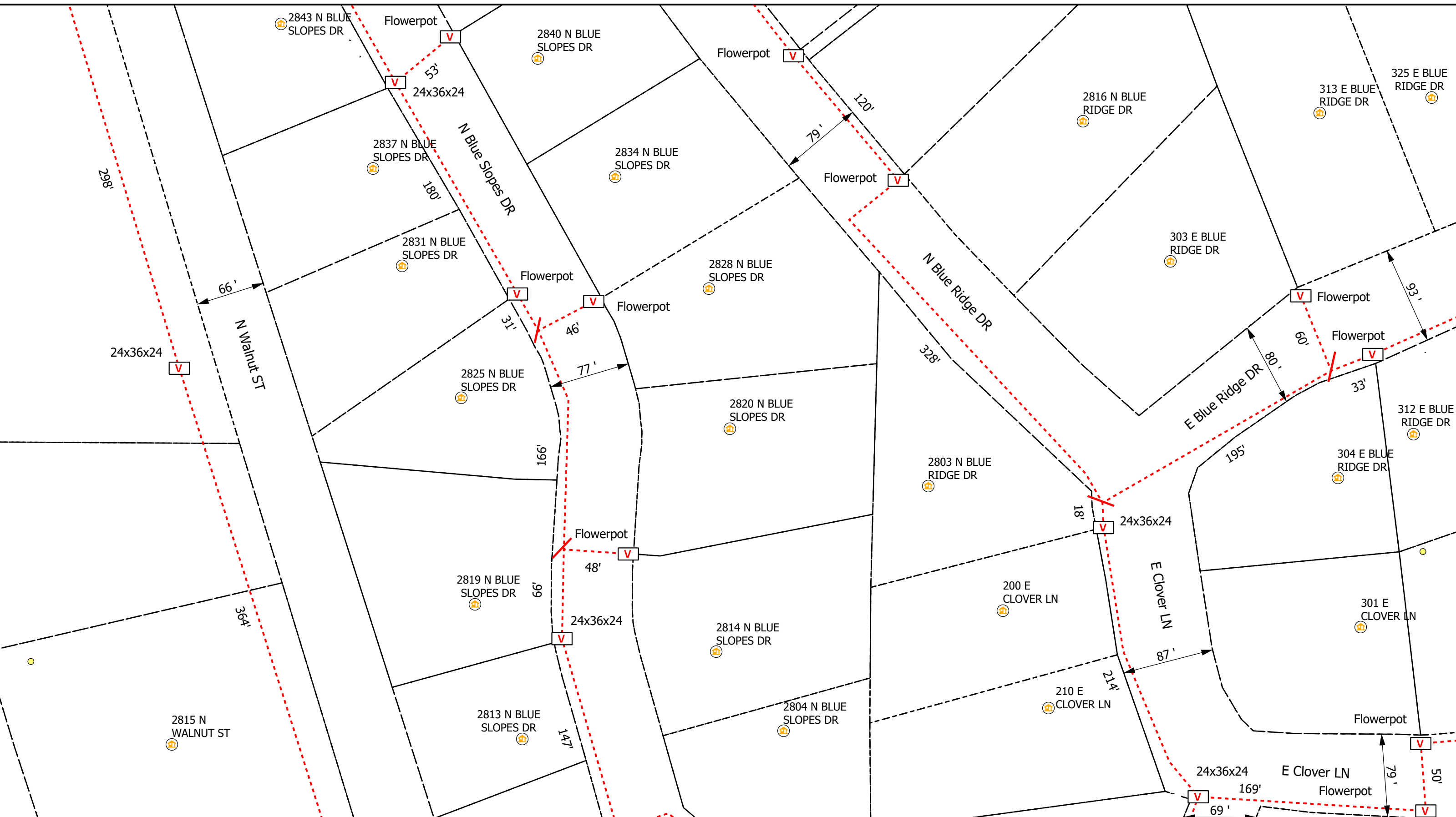

**Legend**

- Poles
- V Vaults
- Overhead Strand
- Conduit
- Bloomington\_Parcels
- R Risers
- ⊙ Address
- Y Anchor
- ← Sidewalk
- Grids

All Flowerpots 12" DIA



City of Bloomington, IN Permit:  
Design View

INI	BY	DATE	DESCRIPTION



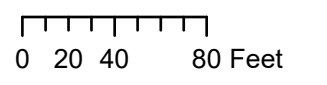
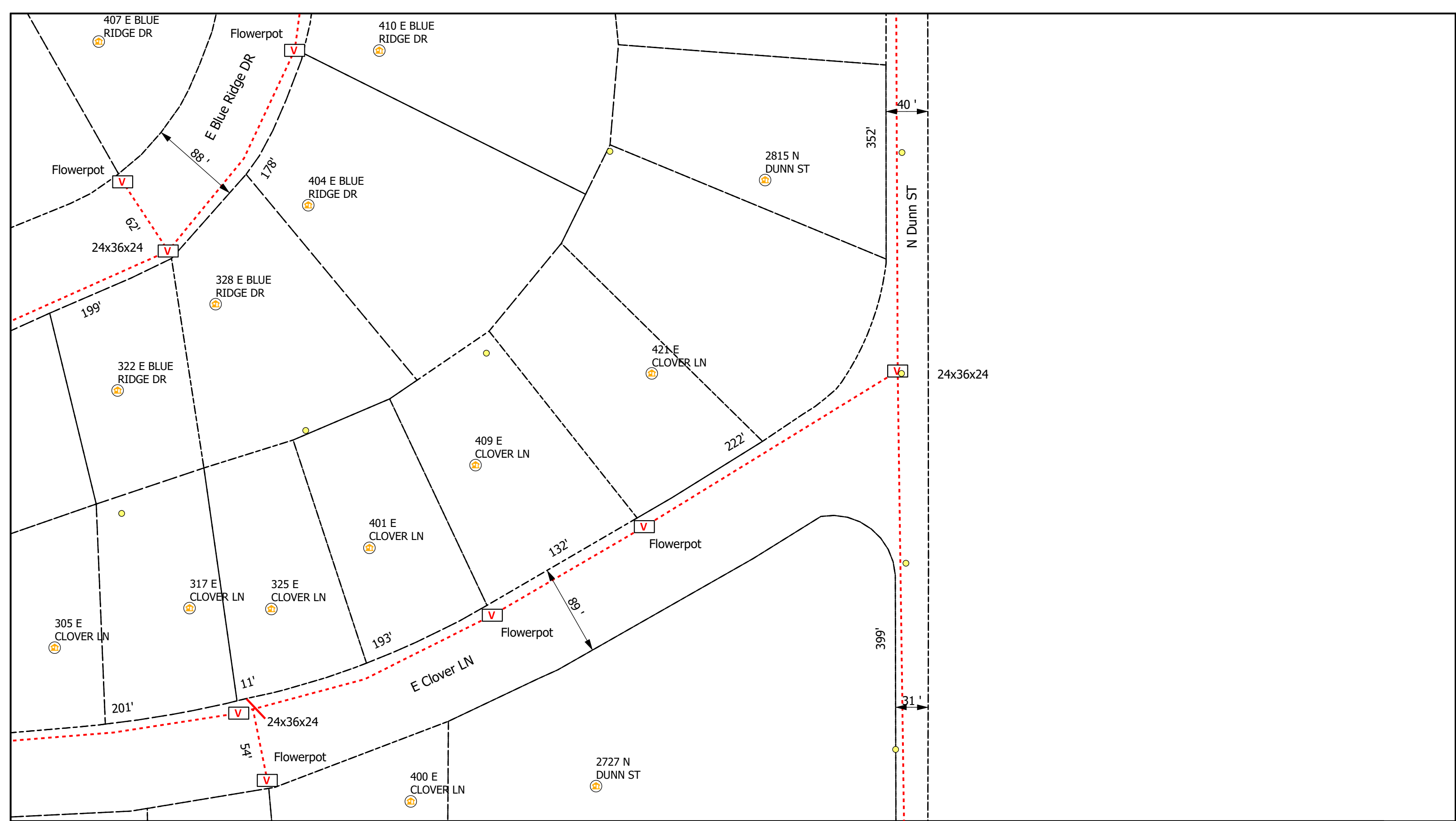

**Legend**

- Poles
- Vaults
- Overhead Strand
- Conduit
- Bloomington\_Parcels
- Risers
- Address
- Anchor
- Sidewalk
- Grids

All Flowerpots 12" DIA



City of Bloomington, IN Permit:  
Design View

INI	BY	DATE	DESCRIPTION





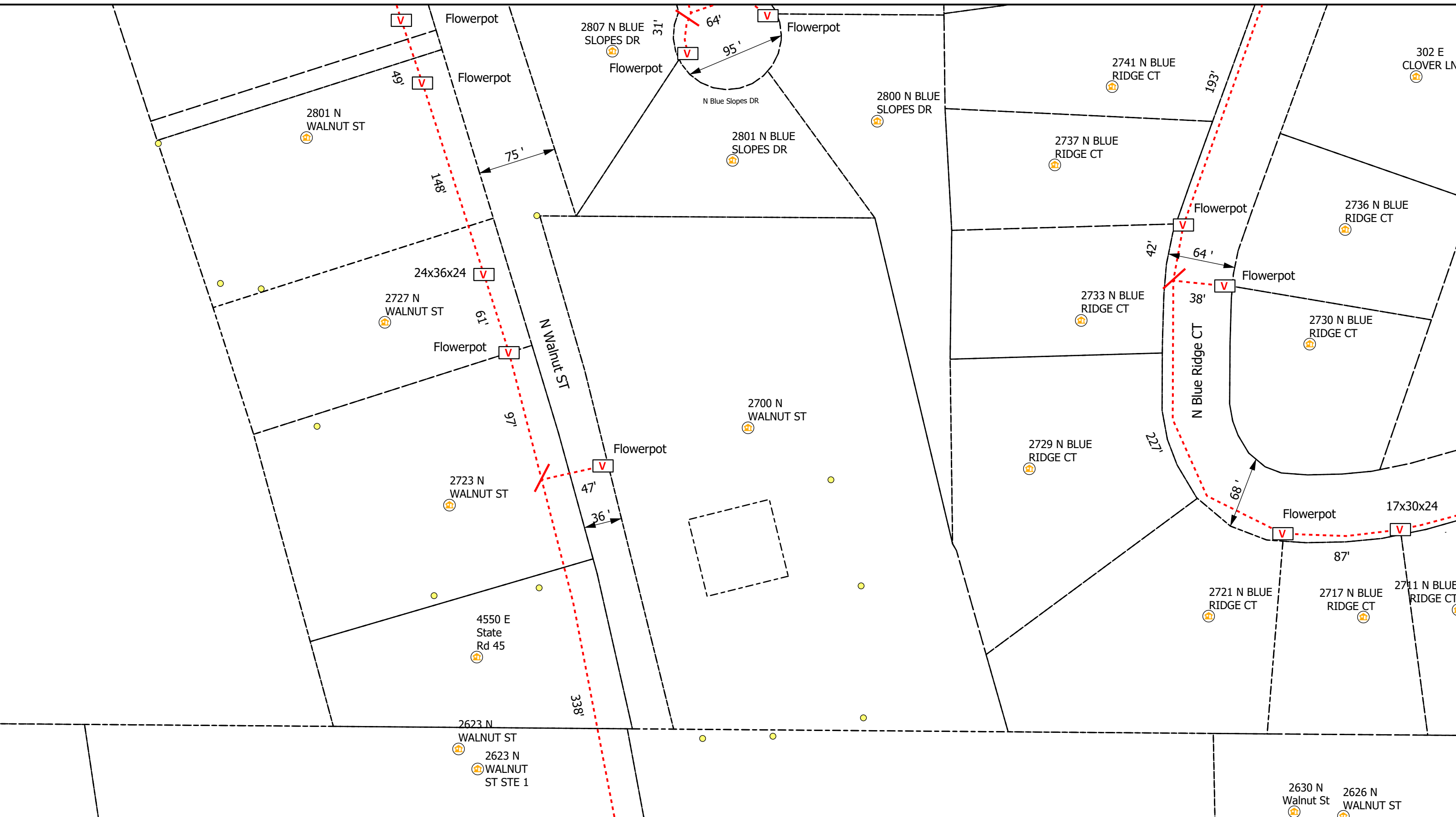

**Legend**

- Poles
- V Vaults
- Overhead Strand
- Conduit
- Bloomington\_Parcels
- R Risers
- A Address
- Y Anchor
- ← Sidewalk
- Grids

All Flowerpots 12" DIA

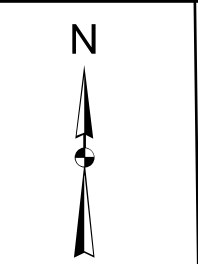

City of Bloomington, IN Permit:  
Design View

INI	BY	DATE	DESCRIPTION

Print 14 of 36

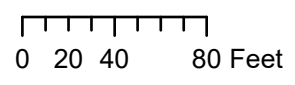
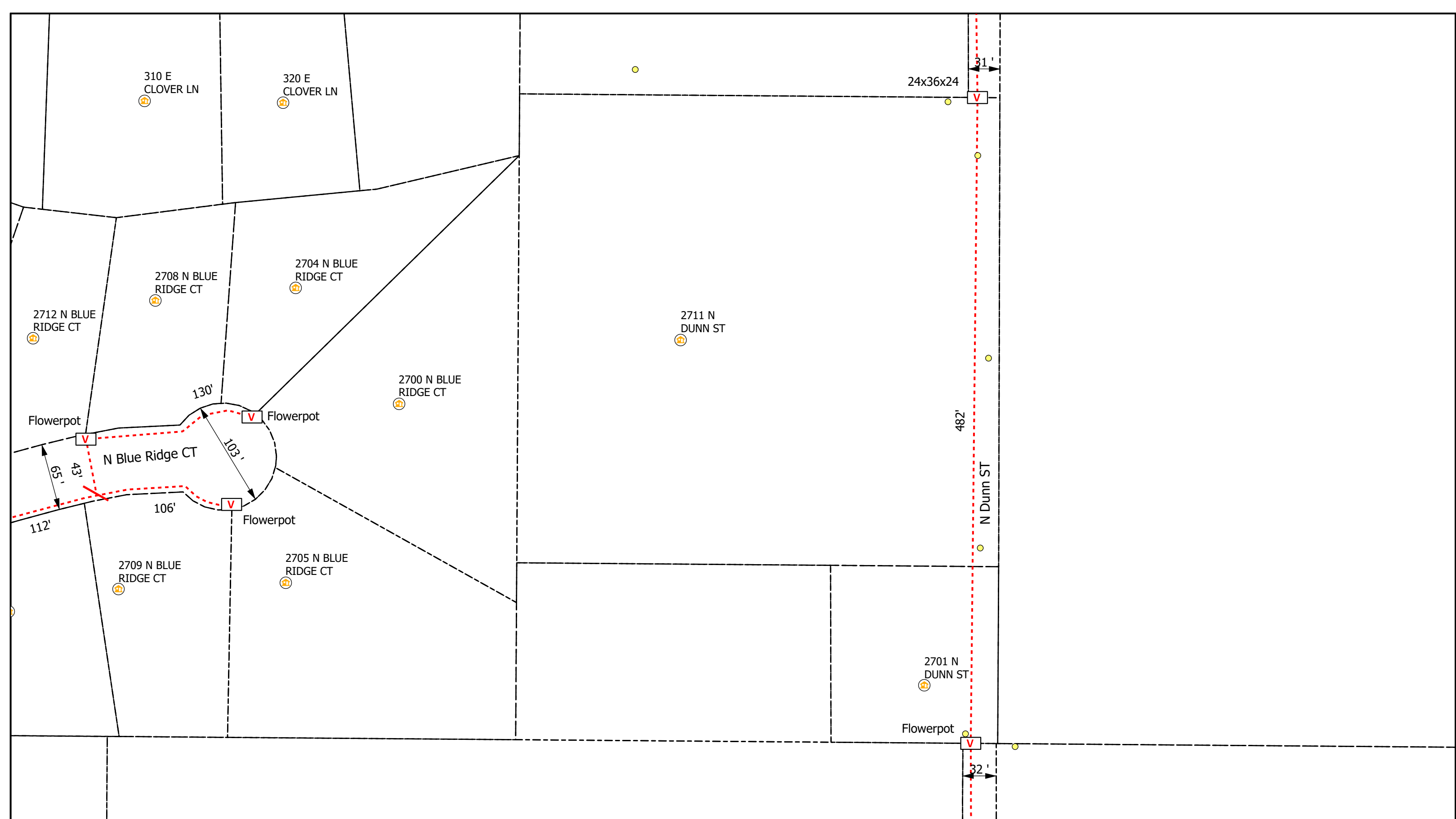

**Legend**

- Poles
- V Vaults
- Overhead Strand
- - - Conduit
- Bloomington\_Parcels
- R Risers
- A Address
- Y Anchor
- ← Sidewalk
- Grids

All Flowerpots 12" DIA



City of Bloomington, IN Permit:  
Design View

INI	BY	DATE	DESCRIPTION



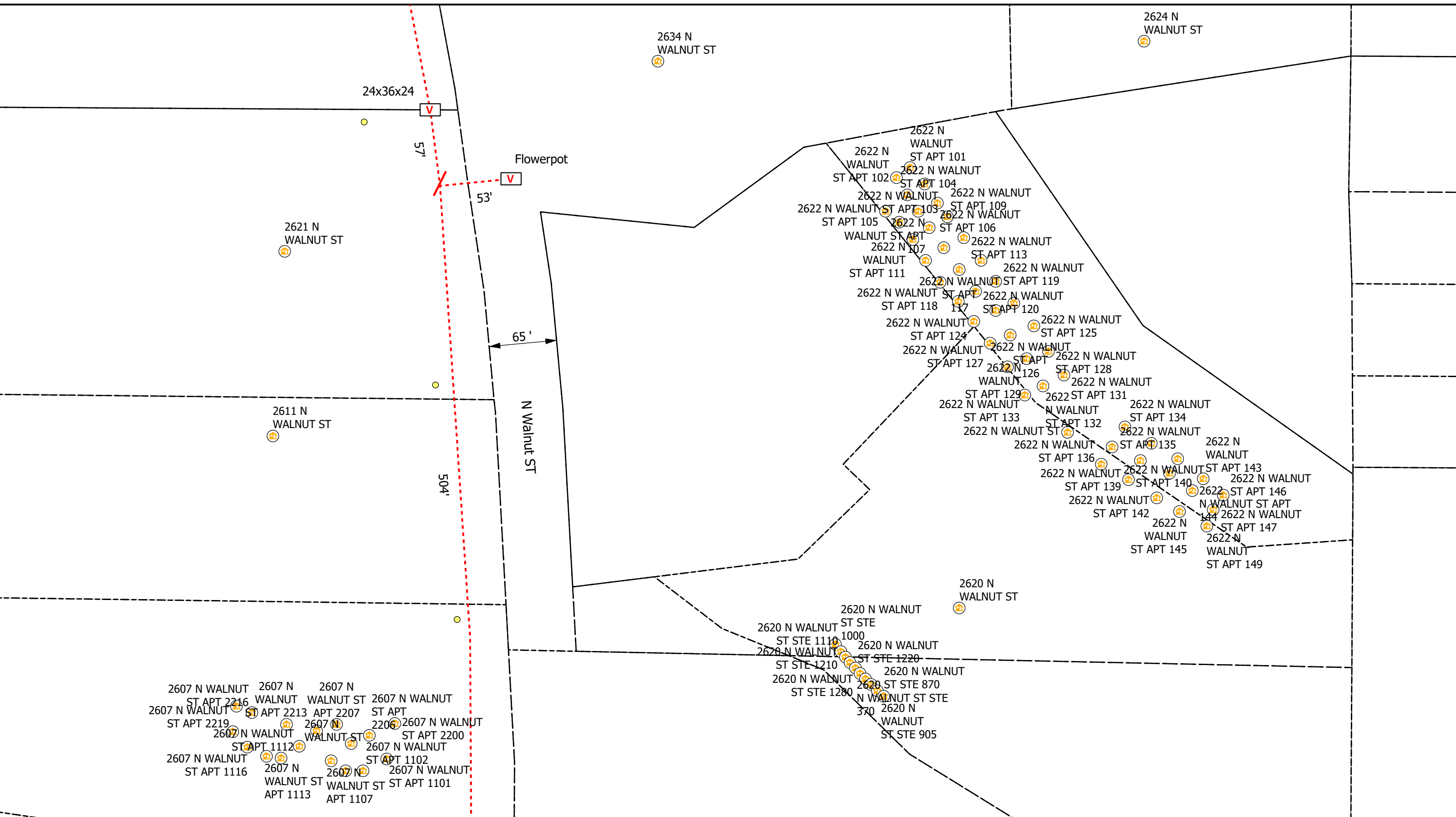

0 20 40 80 Feet

**Legend**

- Poles
- V Vaults
- Overhead Strand
- Conduit
- Bloomington\_Parcels
- R Risers
- A Address
- Y Anchor
- ← Sidewalk
- Grids

All Flowerpots 12" DIA

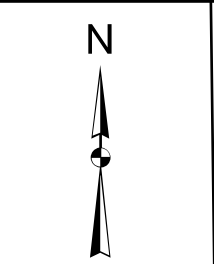

City of Bloomington, IN Permit:  
Design View

INI	BY	DATE	DESCRIPTION

Print 16 of 36

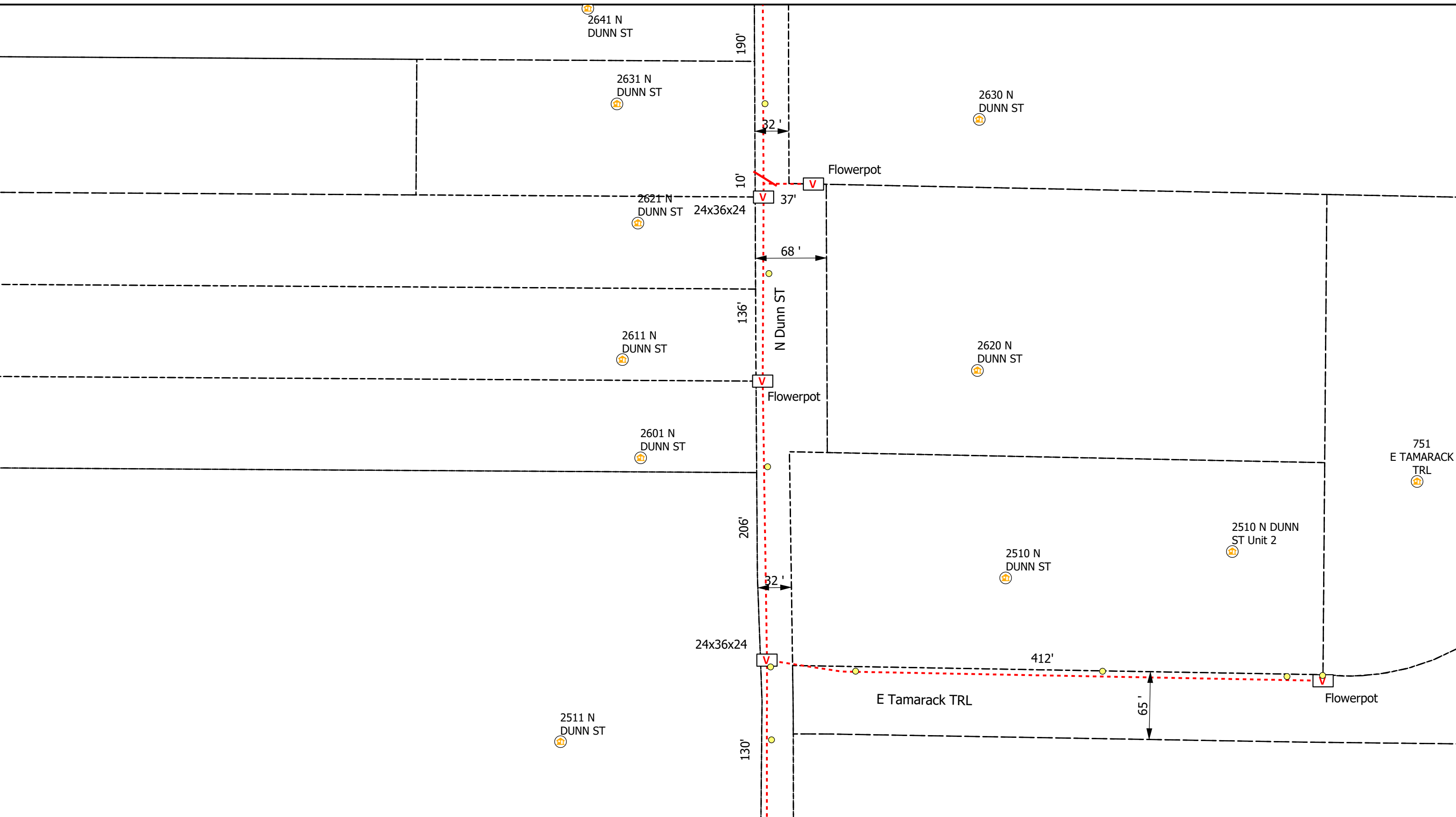

**Legend**

- Poles
- V Vaults
- Overhead Strand
- Conduit
- Bloomington\_Parcels
- R Risers
- A Address
- Y Anchor
- ← Sidewalk
- Grids

All Flowerpots 12" DIA

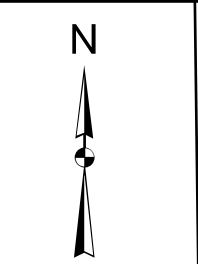

City of Bloomington, IN Permit:  
Design View

INI	BY	DATE	DESCRIPTION



Print 17 of 36

1025 E  
SASSAFRAS  
CIR

E Sassafras CIR

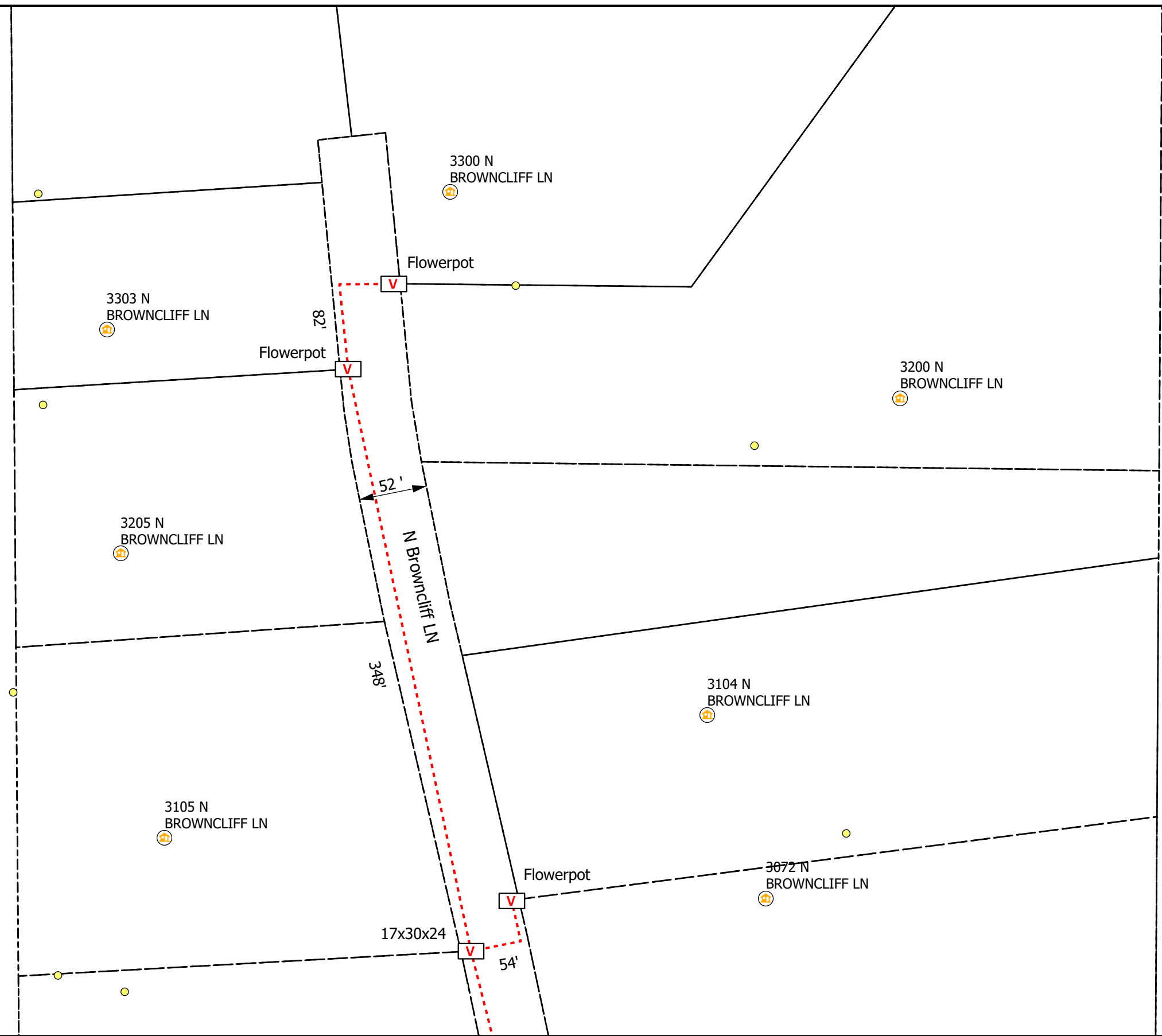

**Legend**

- Poles
- V Vaults
- Overhead Strand
- Conduit
- Bloomington\_Parcels
- R Risers
- A Address
- Y Anchor
- ← Sidewalk
- Grids

All Flowerpots 12" DIA



City of Bloomington, IN Permit:  
Design View

INI	BY	DATE	DESCRIPTION





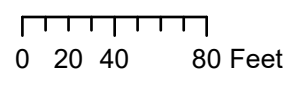
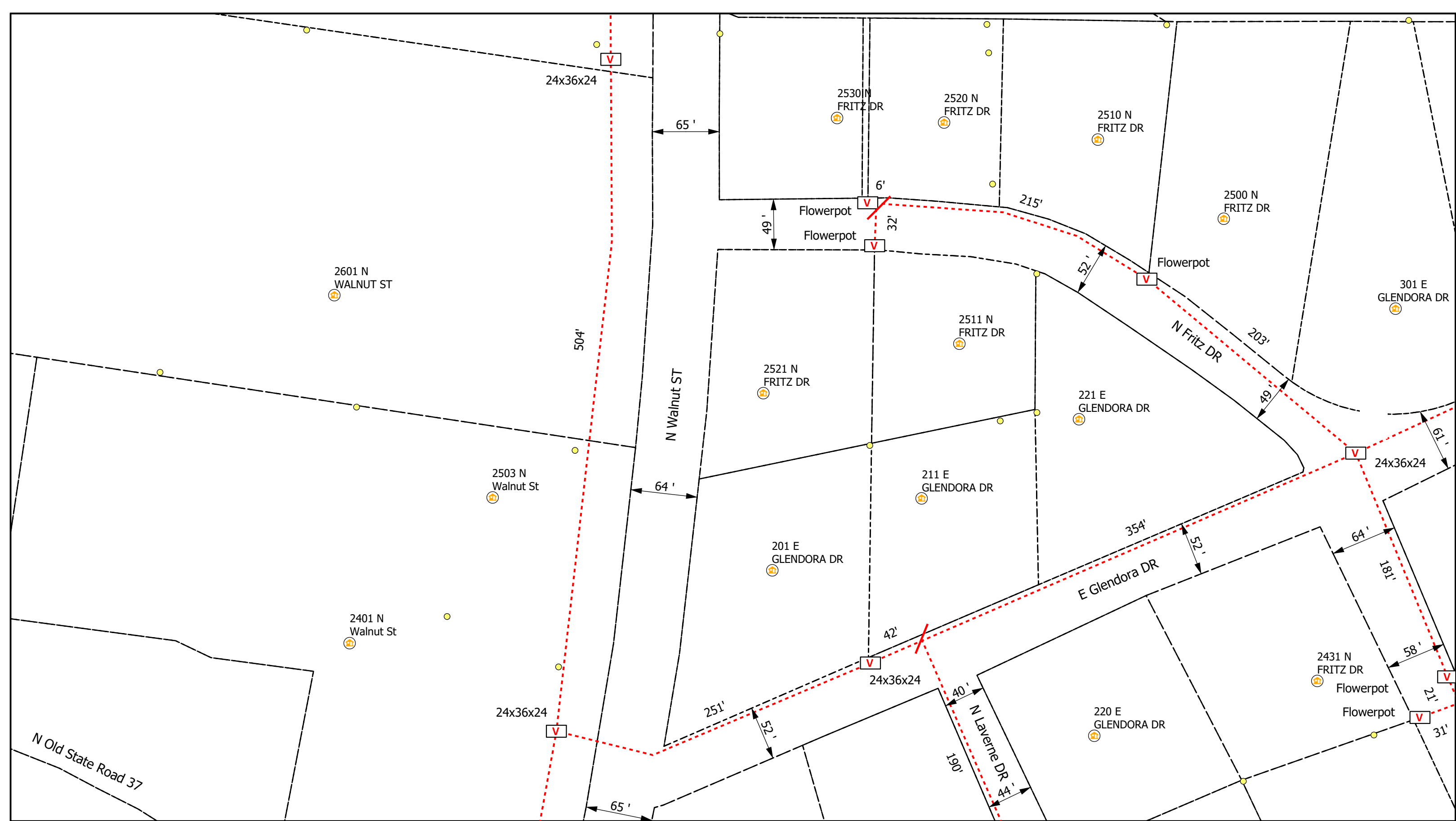

**Legend**

- Poles
- Vaults
- Overhead Strand
- Conduit
- Bloomington\_Parcels
- Risers
- Address
- Anchor
- Sidewalk
- Grids

All Flowerpots 12" DIA



City of Bloomington, IN Permit:  
Design View

INI	BY	DATE	DESCRIPTION



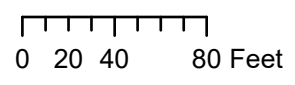
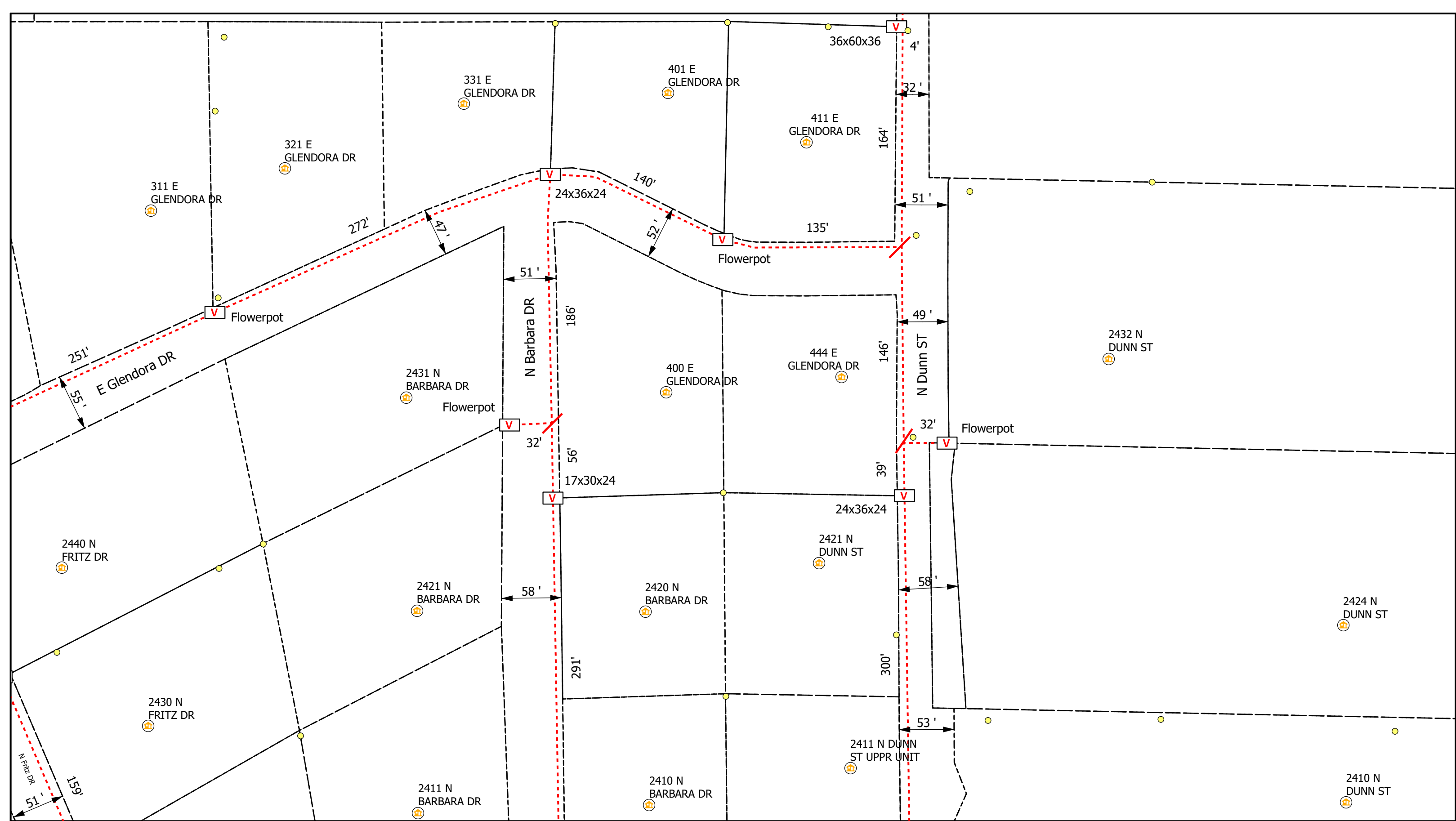

**Legend**

- Poles
- V Vaults
- Overhead Strand
- Conduit
- Bloomington\_Parcels
- R Risers
- A Address
- Y Anchor
- ← Sidewalk
- Grids

All Flowerpots 12" DIA



City of Bloomington, IN Permit:  
Design View

INI	BY	DATE	DESCRIPTION



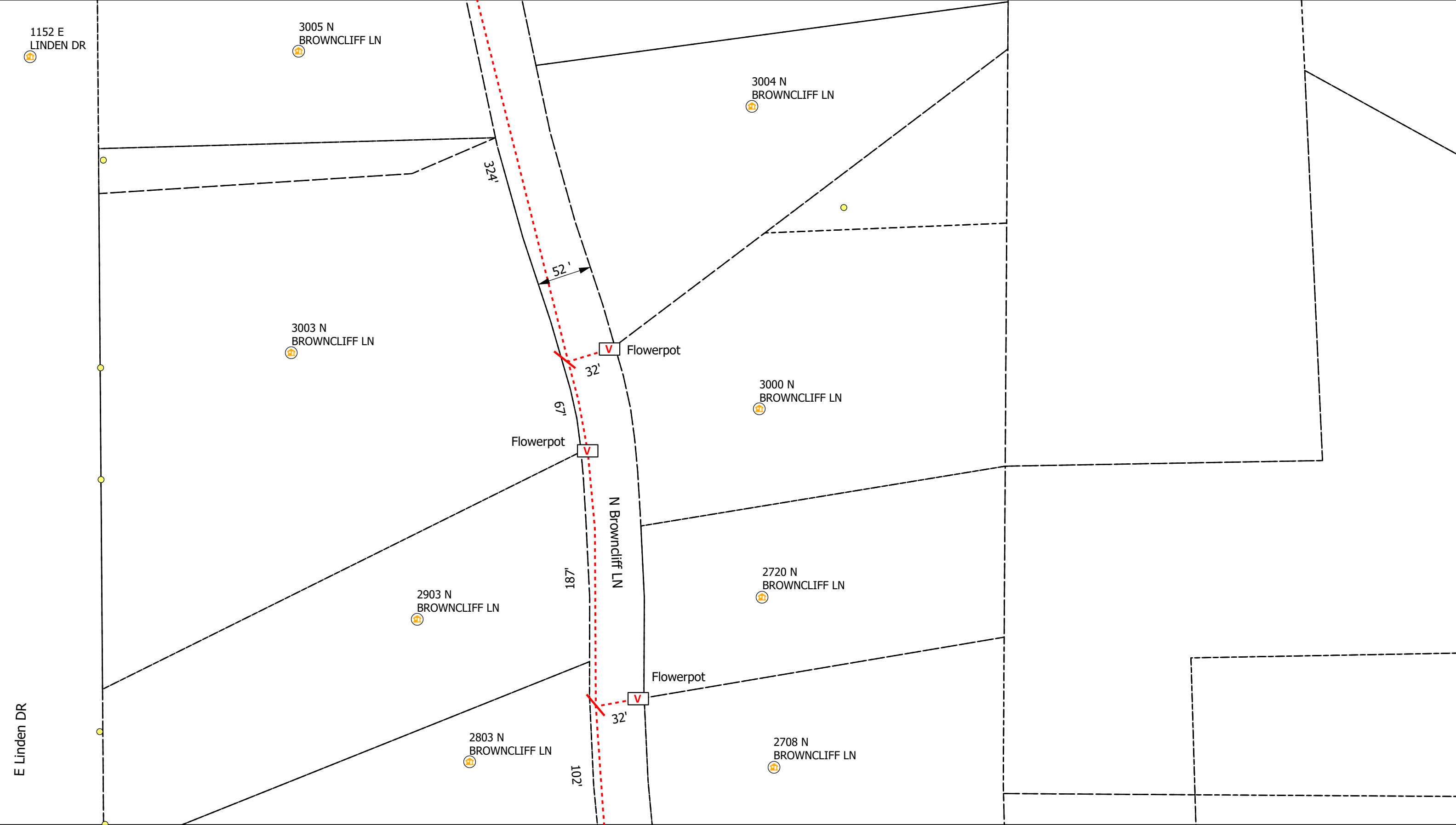

**AEG**

0 20 40 80 Feet

**Legend**

- Poles
- Vaults
- Overhead Strand
- Conduit
- Bloomington\_Parcels
- Risers
- Address
- Anchor
- Sidewalk
- Grids

All Flowerpots 12" DIA

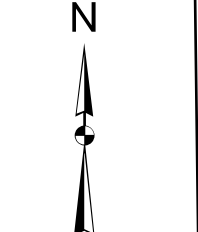

City of Bloomington, IN Permit:  
Design View

INI	BY	DATE	DESCRIPTION

Print 21 of 36

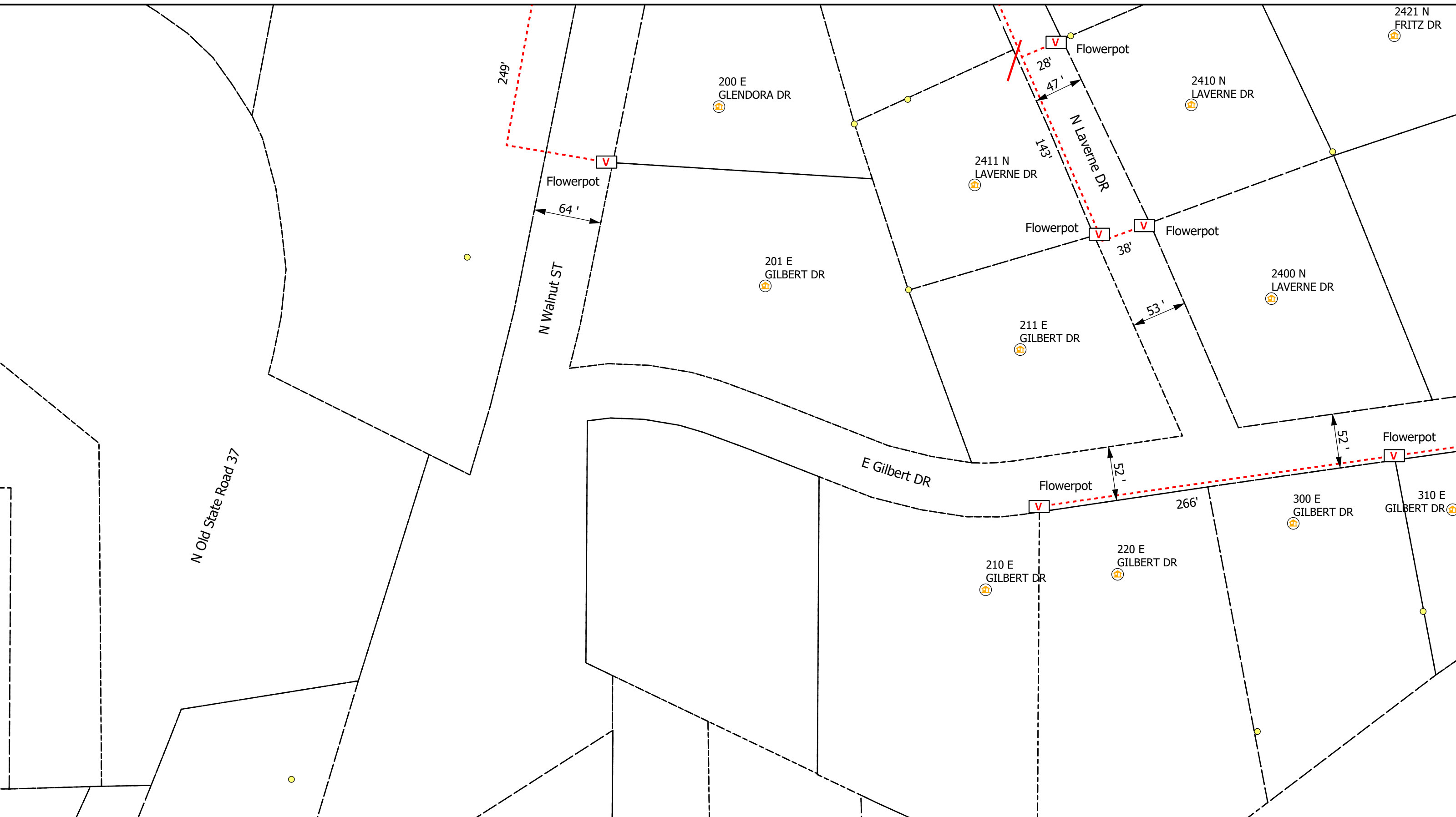

**Legend**

- Poles
- V Vaults
- Overhead Strand
- Conduit
- Bloomington\_Parcels
- R Risers
- H Address
- Y Anchor
- ← Sidewalk
- Grids

All Flowerpots 12" DIA

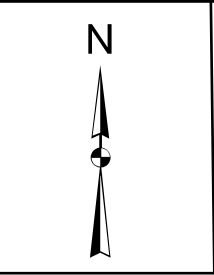

City of Bloomington, IN Permit:  
Design View

INI	BY	DATE	DESCRIPTION

Print 22 of 36

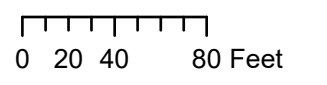
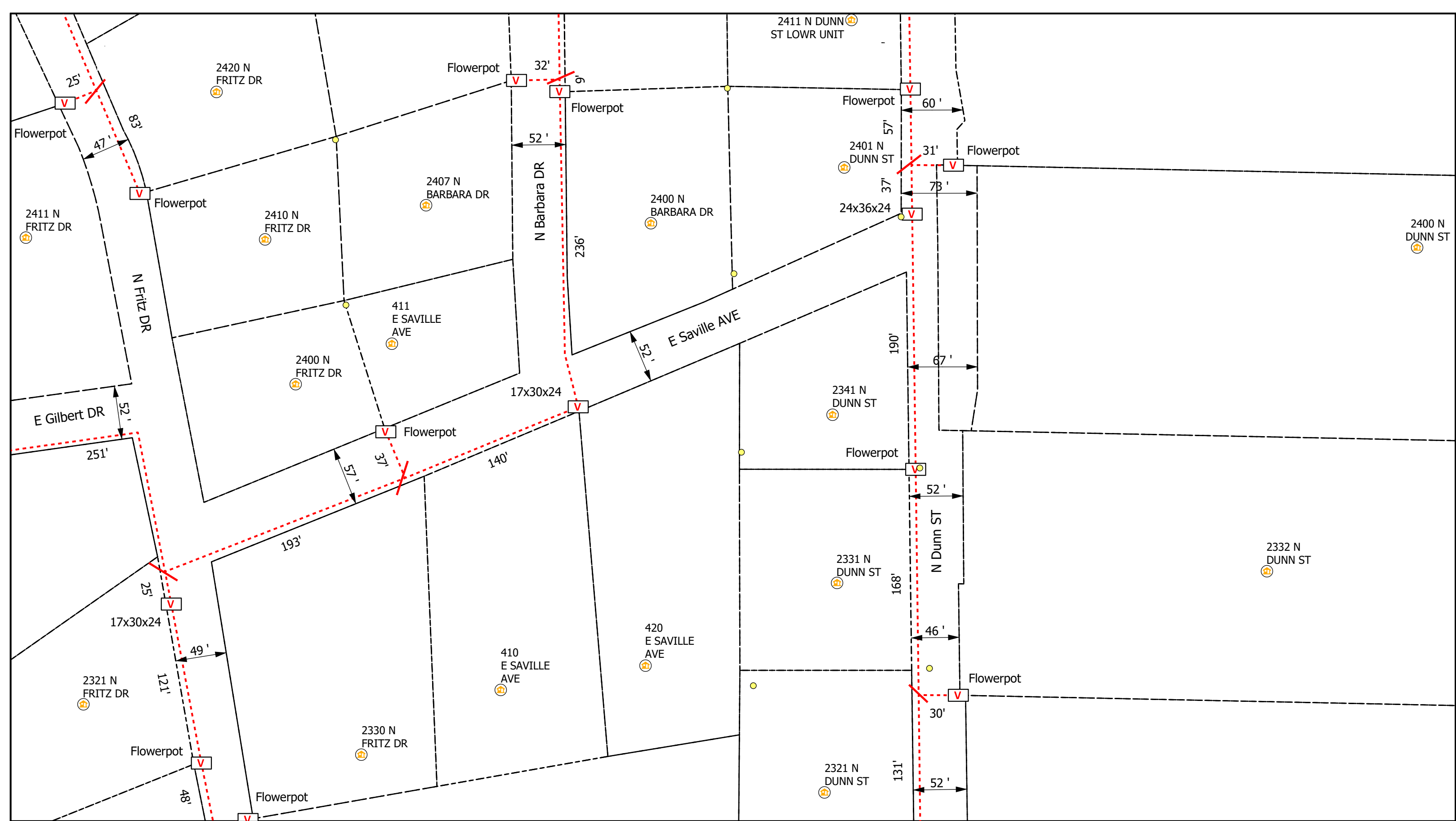

**Legend**

- Poles
- Vaults
- Overhead Strand
- Conduit
- Bloomington\_Parcels
- R Risers
- A Address
- Anchor
- Sidewalk
- Grids

All Flowerpots 12" DIA



City of Bloomington, IN Permit:  
Design View

INI	BY	DATE	DESCRIPTION





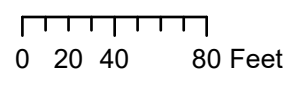
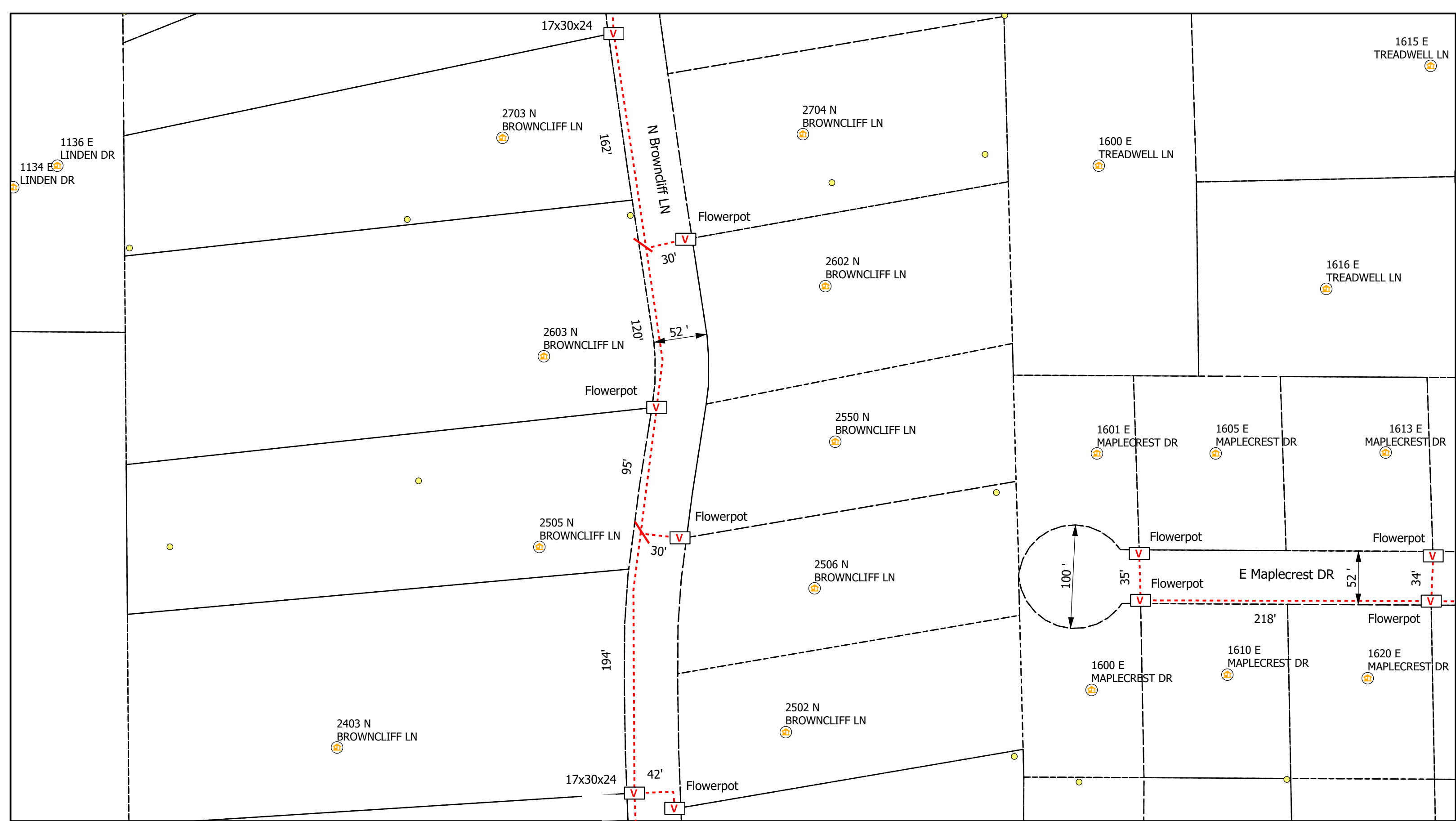

**Legend**

- Poles
- V Vaults
- Overhead Strand
- Conduit
- Bloomington\_Parcels
- R Risers
- A Address
- Y Anchor
- ← Sidewalk
- Grids

All Flowerpots 12" DIA



City of Bloomington, IN Permit:  
Design View

INI	BY	DATE	DESCRIPTION



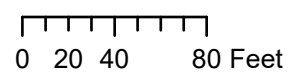
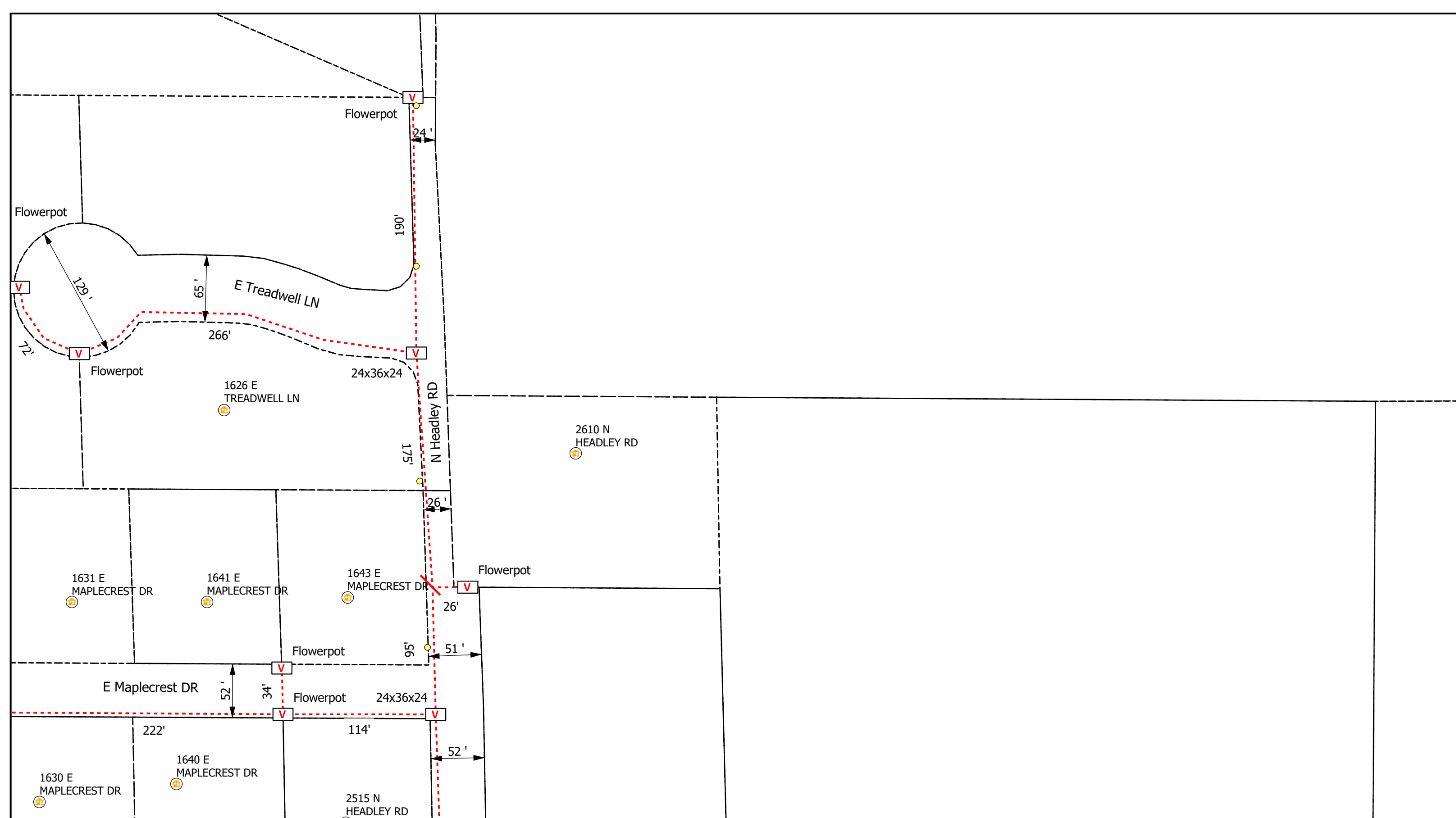

**Legend**

- Poles
- Vaults
- Overhead Strand
- Conduit
- Bloomington\_Parcels
- Risers
- Address
- Anchor
- Sidewalk
- Grids

All Flowerpots 12" DIA



City of Bloomington, IN Permit:  
Design View

INI	BY	DATE	DESCRIPTION



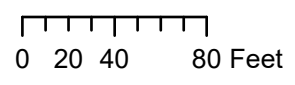

**Legend**

- Poles
- V Vaults
- Overhead Strand
- Conduit
- Bloomington\_Parcels
- R Risers
- A Address
- Y Anchor
- ← Sidewalk
- Grids

All Flowerpots 12" DIA



City of Bloomington, IN Permit:  
Design View

INI	BY	DATE	DESCRIPTION



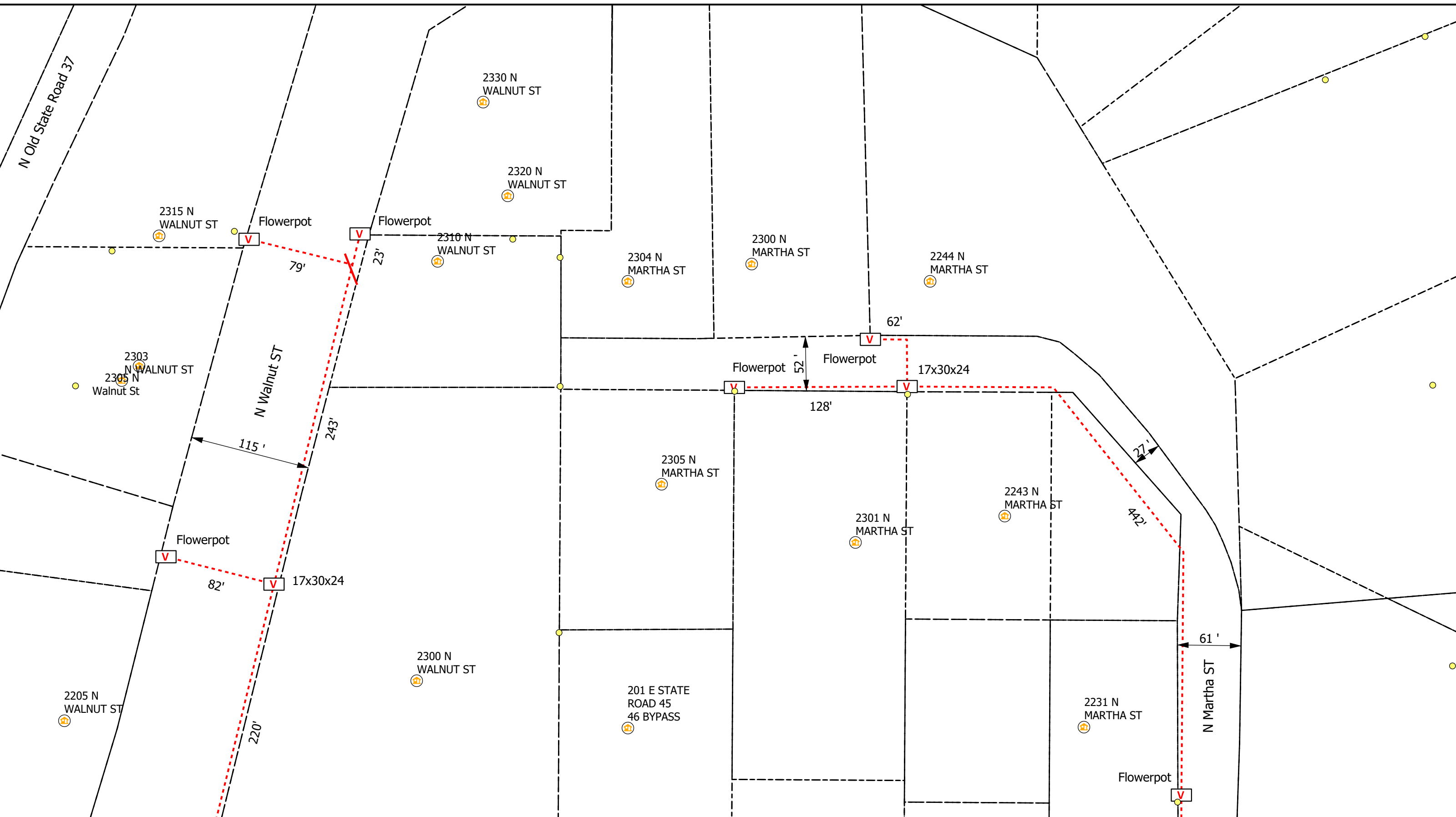

0 20 40 80 Feet

**Legend**

- Poles
- V Vaults
- Overhead Strand
- Conduit
- Bloomington\_Parcels
- R Risers
- A Address
- Y Anchor
- ← Sidewalk
- Grids

All Flowerpots 12" DIA

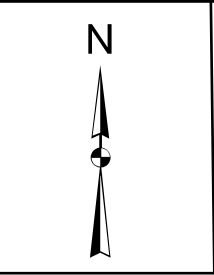

City of Bloomington, IN Permit:  
Design View

INI	BY	DATE	DESCRIPTION

Print 27 of 36

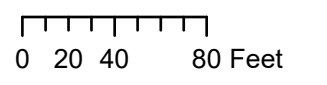
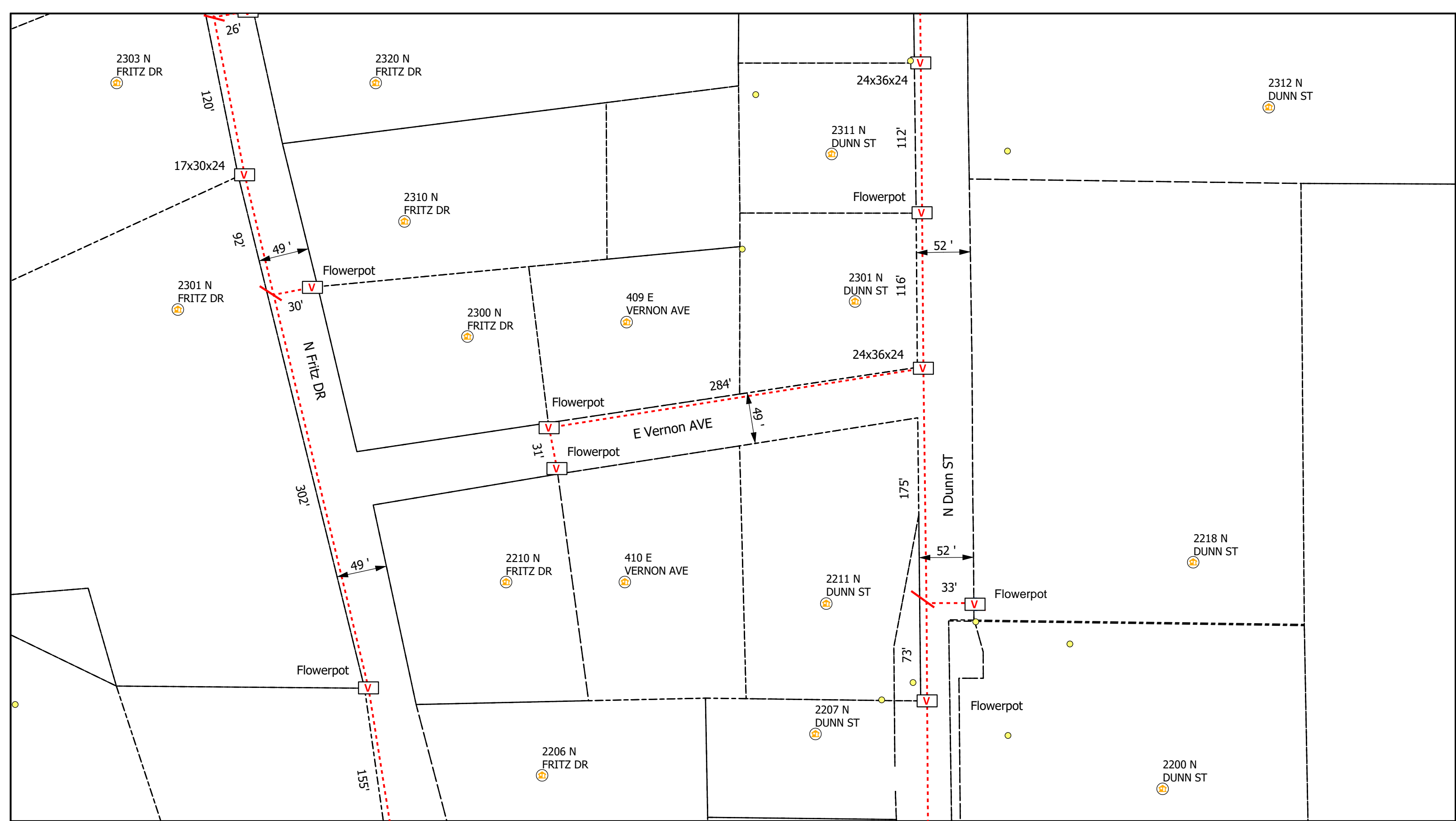

**Legend**

- Poles
- Vaults
- Overhead Strand
- Conduit
- Bloomington\_Parcels
- Risers
- Address
- Anchor
- Sidewalk
- Grids

All Flowerpots 12" DIA



City of Bloomington, IN Permit:  
Design View

INI	BY	DATE	DESCRIPTION



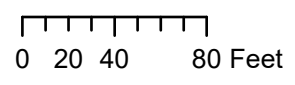
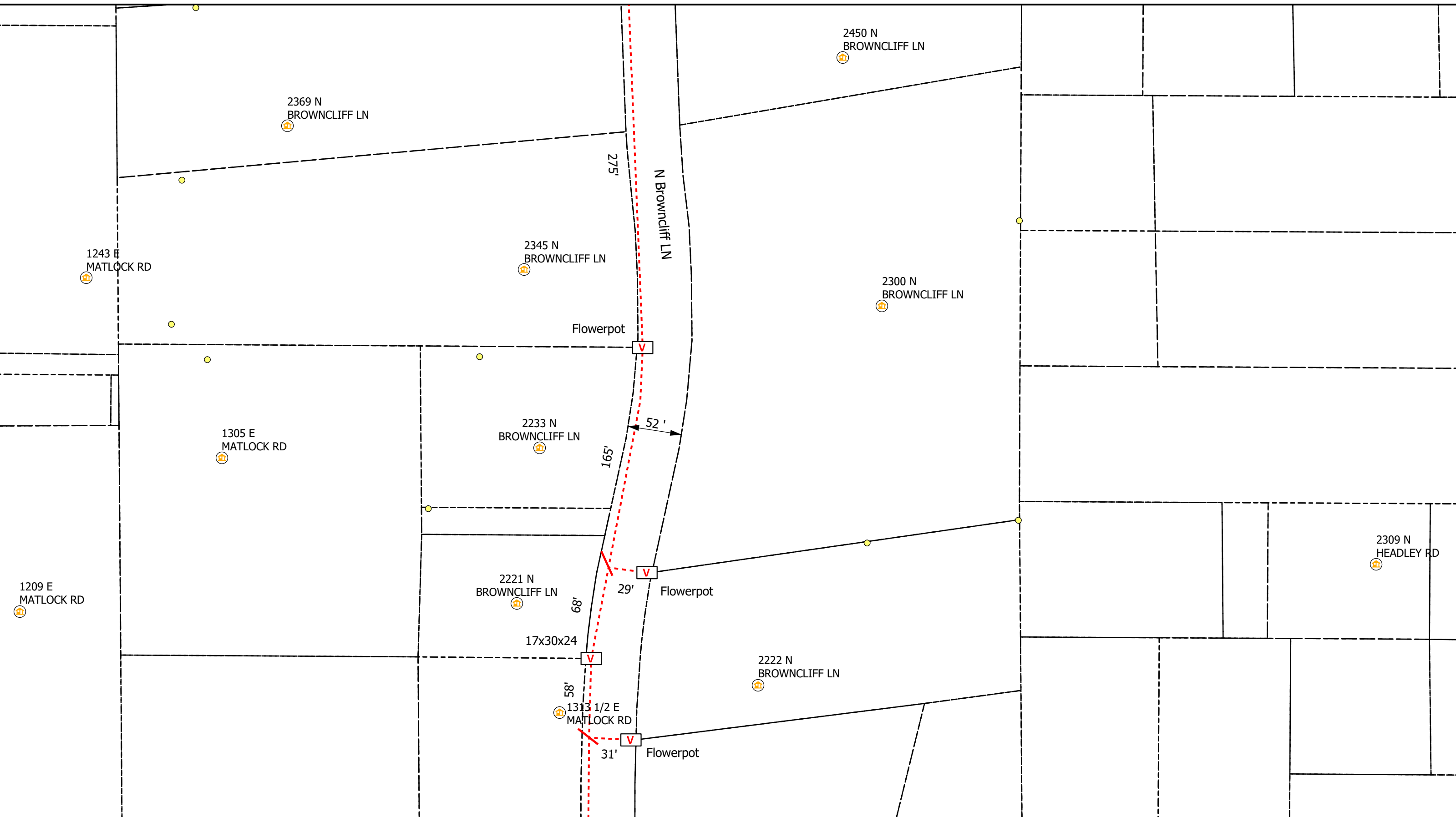

**Legend**

- Poles
- V Vaults
- Overhead Strand
- Conduit
- Bloomington\_Parcels
- R Risers
- A Address
- Y Anchor
- ← Sidewalk
- Grids

All Flowerpots 12" DIA



City of Bloomington, IN Permit:  
Design View

INI	BY	DATE	DESCRIPTION





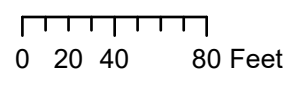
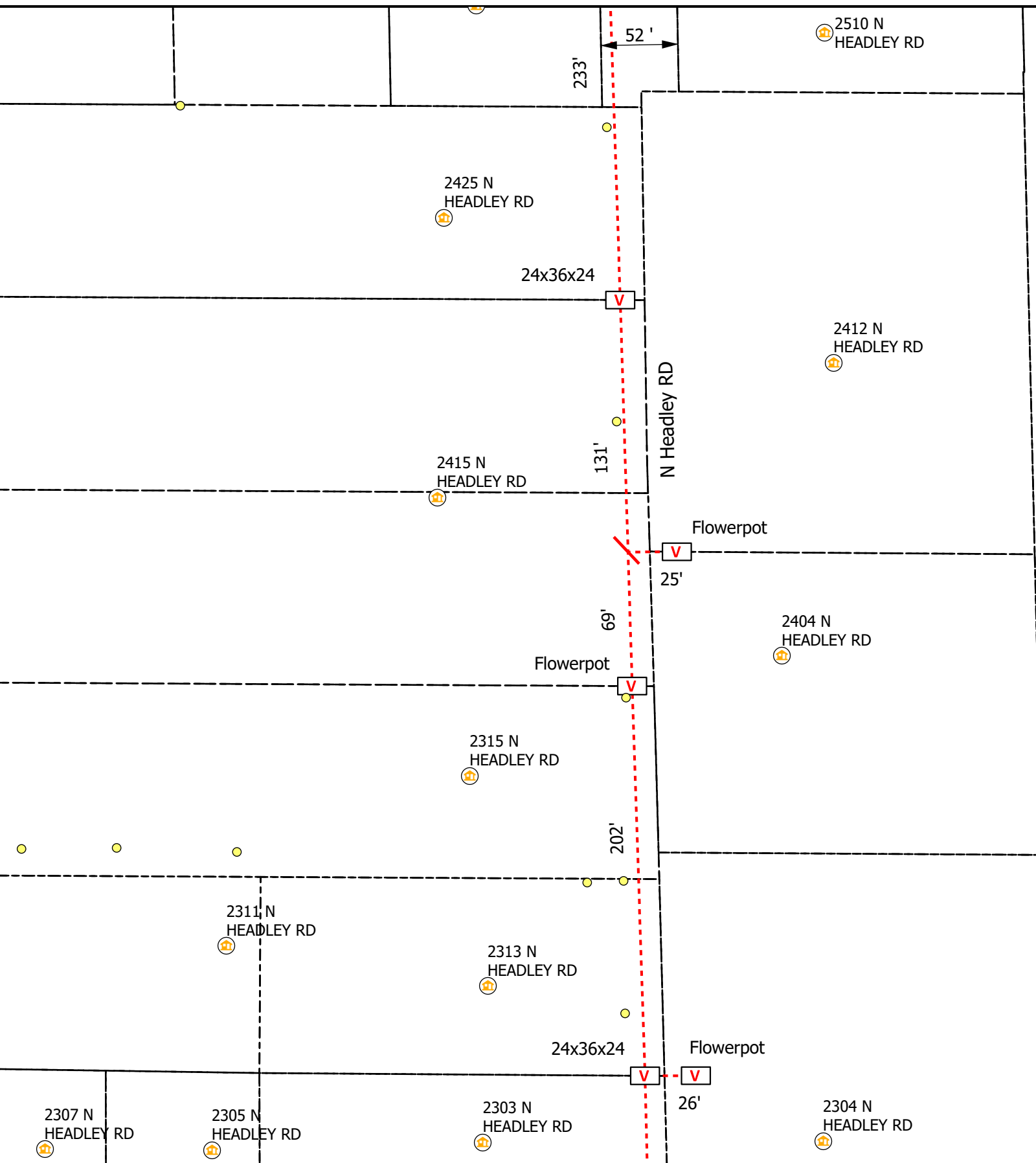

**Legend**

- Poles
- V Vaults
- Overhead Strand
- Conduit
- Bloomington\_Parcels
- R Risers
- A Address
- Y Anchor
- ← Sidewalk
- Grids

All Flowerpots 12" DIA



City of Bloomington, IN Permit:  
Design View

INI	BY	DATE	DESCRIPTION



194'

194'

436'

51'

W State Road 45 46 Bypass

76'

N Kinser PIKE

N Old State Road 37

1720 N KINSER  
PIKE STE 001

1720 N KINSER  
PIKE STE 110

1720 N KINSER  
PIKE STE 200

1720 N KINSER  
PIKE STE 210

1720 N KINSER  
PIKE

1710 N KINSER PIKE

1700 N KINSER PIKE

1705 N KINSER PIKE

W Gourley PIKE

Continues onto INDOT Permit



0 20 40 80 Feet

Legend

- Poles
- Vaults
- Overhead Strand
- Conduit
- Bloomington\_Parcels
- Risers
- Address
- Anchor
- Sidewalk
- Grids

All Flowerpots 12" DIA



City of Bloomington, IN Permit:  
Design View

INI	BY	DATE	DESCRIPTION



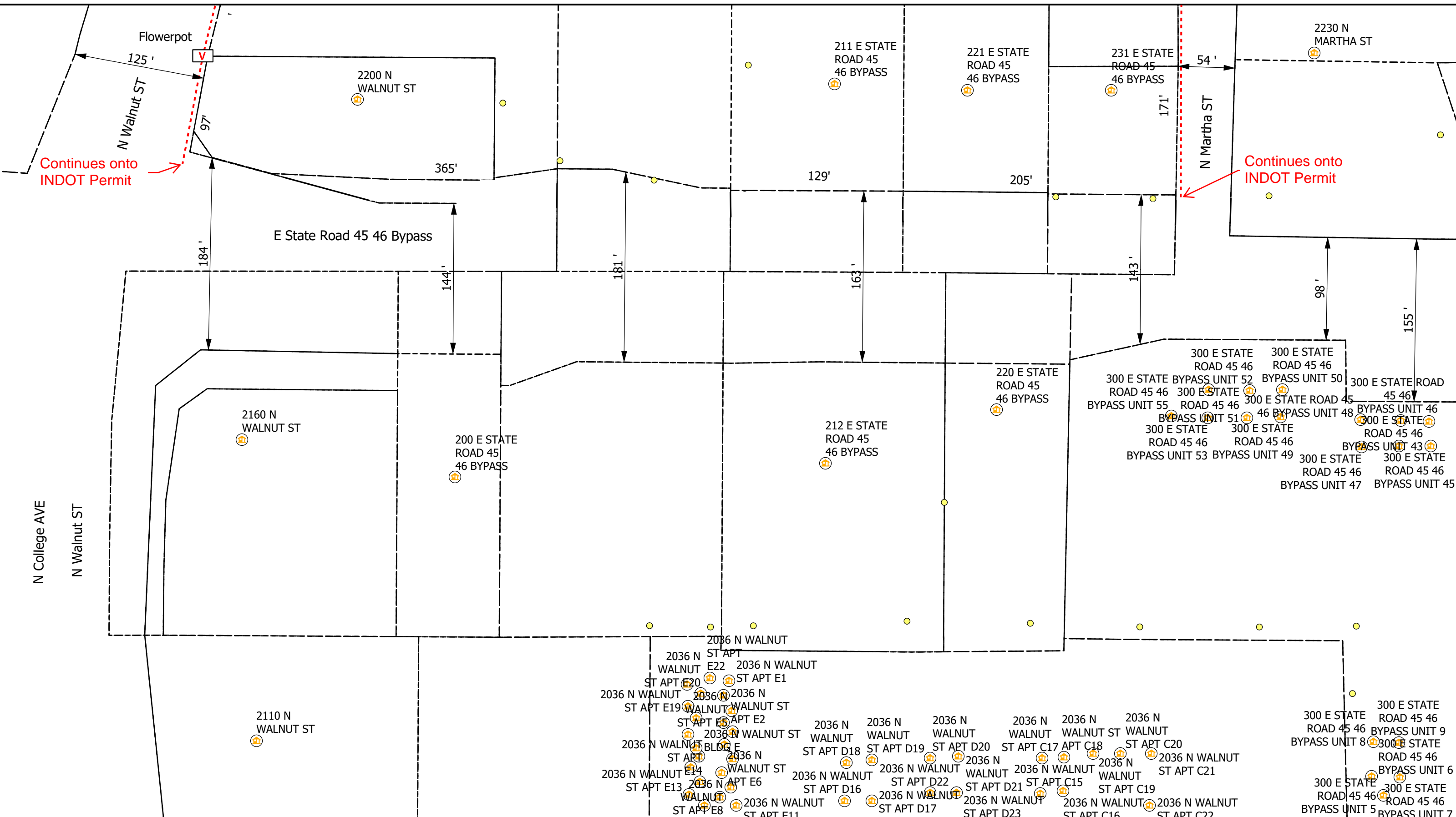

**AEG**

0 20 40 80 Feet

**Legend**

- Poles
- ⓧ Vaults
- Overhead Strand
- - - Conduit
- Ⓜ Bloomington\_Parcels
- Ⓜ Risers
- Ⓜ Address
- Ⓜ Anchor
- Ⓜ Sidewalk
- Ⓜ Grids

All Flowerpots 12" DIA

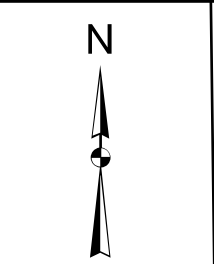

City of Bloomington, IN Permit:  
Design View

INI	BY	DATE	DESCRIPTION

Print 32 of 36

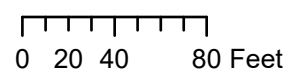
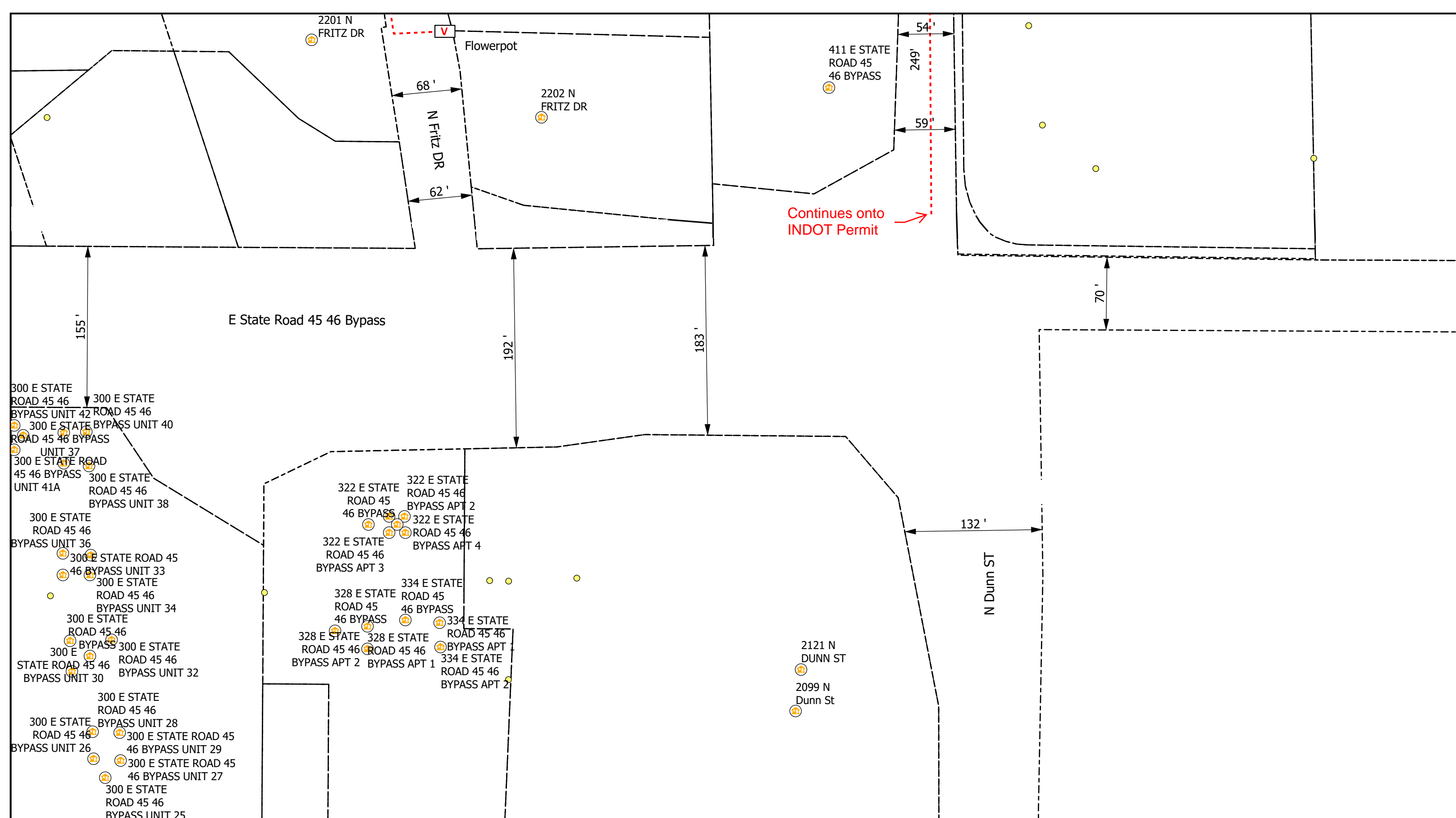

**Legend**

- Poles
- Vaults
- Overhead Strand
- Conduit
- Bloomington\_Parcels
- Risers
- Address
- Anchor
- Sidewalk
- Grids

All Flowerpots 12" DIA



City of Bloomington, IN Permit:  
Design View

INI	BY	DATE	DESCRIPTION



1203 E  
MATLOCK RD

N Milo B Sampson LN

237'

Continues onto  
INDOT permit.

E Matlock RD

E State Road 45 46 Bypass

N State Road 45 46 Bypass

N Fee LN

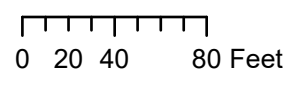

Legend

- Poles
- Vaults
- Overhead Strand
- Conduit
- Bloomington\_Parcels
- R Risers
- A Address
- Anchor
- Sidewalk
- Grids

All Flowerpots 12" DIA



City of Bloomington, IN Permit:  
Design View

INI	BY	DATE	DESCRIPTION



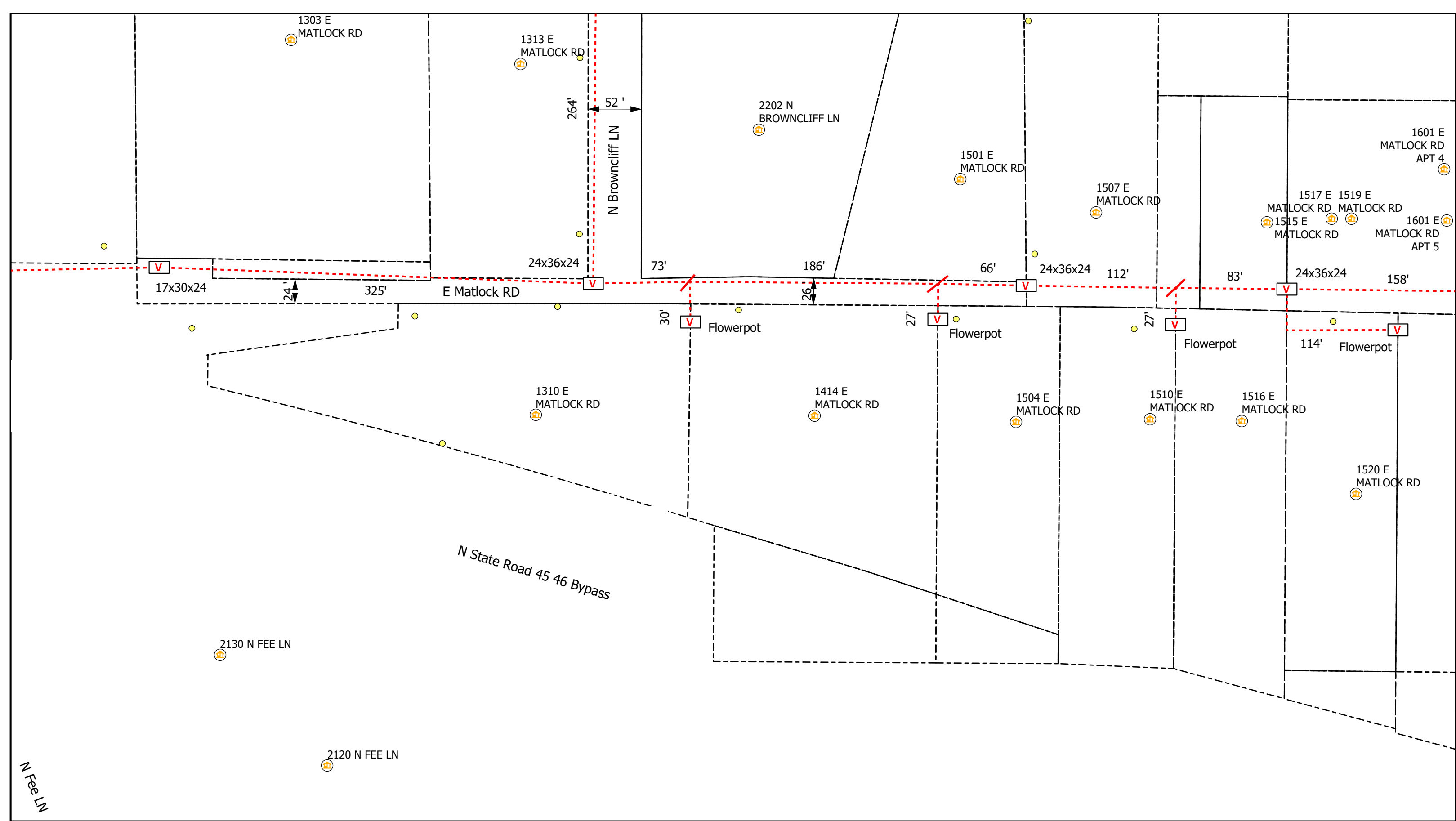

0 20 40 80 Feet

**Legend**

- Poles
- V Vaults
- Overhead Strand
- - - Conduit
- Bloomington\_Parcels
- R Risers
- A Address
- Y Anchor
- ← Sidewalk
- Grids

All Flowerpots 12" DIA

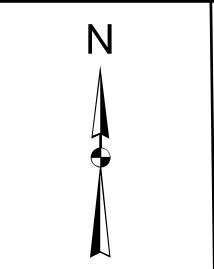

City of Bloomington, IN Permit:  
Design View

INI	BY	DATE	DESCRIPTION

Print 35 of 36



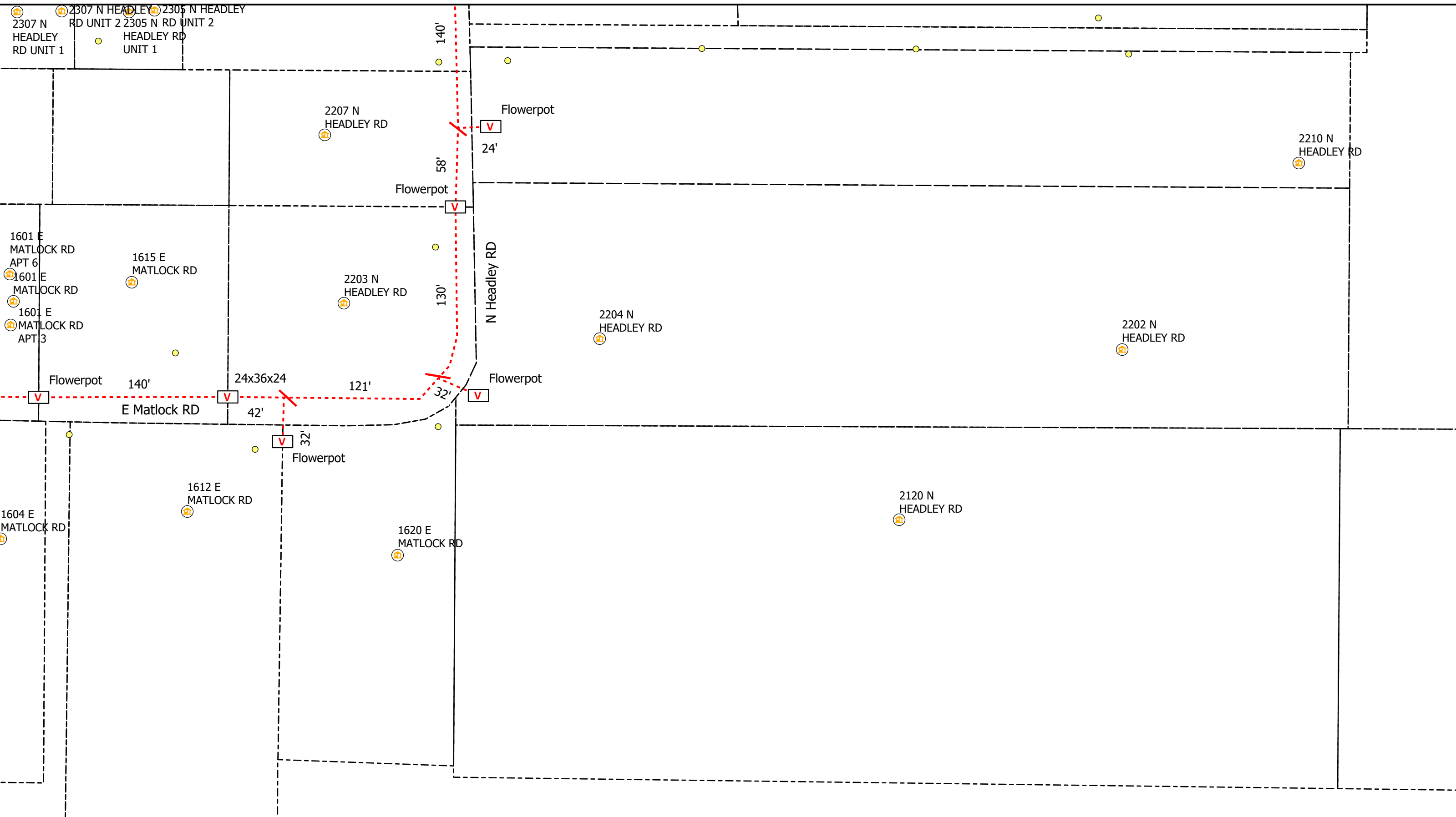

**Legend**

- Poles
- V Vaults
- Overhead Strand
- - - Conduit
- Bloomington\_Parcels
- R Risers
- A Address
- Y Anchor
- ← Sidewalk
- Grids

All Flowerpots 12" DIA

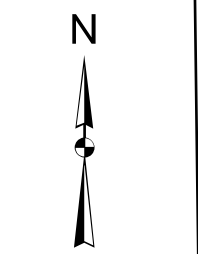

City of Bloomington, IN Permit:  
Design View

INI	BY	DATE	DESCRIPTION

Print 36 of 36

# Carlton® PV-Mold® Nonmetallic Pole Riser System

Carlton PV-Mold is a nonmetallic pole riser system designed to protect communications power cable installed on poles.

## Features:

- Meets or exceeds requirements outlined in the National Electric Safety Code (NESC).
- Designed in accordance with NEMA TC-19 specifications.
- Ultraviolet, cold temperature and corrosive atmosphere resistant.
- Schedule 40 wall meets Schedule 80 PVC conduit impact requirements per NEMA TC-19.
- No grounding required.
- Belled end fits over each added section or conduit.
- Flame retardant.
- Requires no maintenance.
- PV-Mold acts as an insulator against electrical shock.
- Interchangeable parts and accessories to match the needs of specific requirements.



Steel U-Guard requires grounding strapping and does not have belled ends.



PV-Mold has belled ends, flanged design and does not require grounding.

## Flanged Overall Length 10 Feet, Including Bell

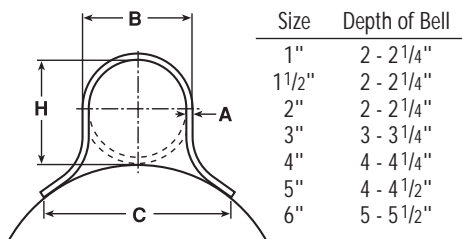

Slots are 1/2" from side to side, and allow for expansion and contraction.

Slot Dimensions: for sizes 2" through 6" are 5/16" wide, 3/4" long.

Slot Dimensions: for 1" and 1 1/2" are 3/16" wide, 3/4" long.

Slot Spacing: 18" from center, beginning 6" from end.

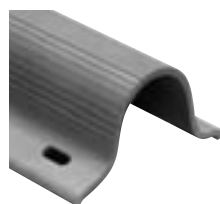

## Standard Duty

Part No.	Size	Std. Ctn. Qty.	Std. Ctn. Wt. (lbs.)	Dimensions				Actual Impact @ 0°C 20 Pound Top
				A	B	C	H	
59208N	1"	294	1059	0.100"	1 5/8"	2 3/8"	1 5/8"	40 Ft.-Lbs.
59211N	2"	136	726	0.100"	2 3/8"	4 1/2"	2 3/8"	100 Ft.-Lbs.
59211X (5' length)	2"	136	363	0.100"	2 3/8"	4 1/2"	2 3/8"	100 Ft.-Lbs.
59213N	3"	66	761	0.150"	3 1/2"	6"	3 1/2"	110 Ft.-Lbs.
59213X (5' length)	3"	66	381	0.150"	3 1/2"	6"	3 1/2"	100 Ft.-Lbs.
59215N	4"	65	910	0.150"	4 1/2"	6 1/2"	4 1/2"	110 Ft.-Lbs.
59216N	5"	30	515	0.150"	5 1/2"	7 1/2"	5 1/2"	110 Ft.-Lbs.

## Heavy Duty Schedule 40

59010N	1 1/2"	200	1142	0.145"	1 29/32"	3 1/2"	1 29/32"	100 Ft.-Lbs.
59011N	2"	136	1214	0.154"	2 3/8"	4 1/2"	2 3/8"	150 Ft.-Lbs.
59013N	3"	66	937	0.216"	3 1/2"	6"	3 9/32"	150 Ft.-Lbs.
59015N	4"	65	1621	0.237"	4 1/2"	6 1/2"	4 1/2"	260 Ft.-Lbs.
59015X (5' length)	4"	65	707	0.237"	4 1/2"	6 1/2"	4 1/2"	260 Ft.-Lbs.
59016N	5"	30	870	0.258"	5 1/2"	7 1/2"	5 1/2"	260 Ft.-Lbs.
59017N	6"	30	1160	0.280"	6 5/8"	8 3/4"	6 5/8"	260 Ft.-Lbs.

## Extra Heavy Duty Schedule 80

59411N	2"	136	1549	0.218"	2 3/8"	4 1/2"	2 3/8"	300 Ft.-Lbs.
59413N	3"	66	1495	0.030"	3 1/2"	6"	3 1/2"	525 Ft.-Lbs.

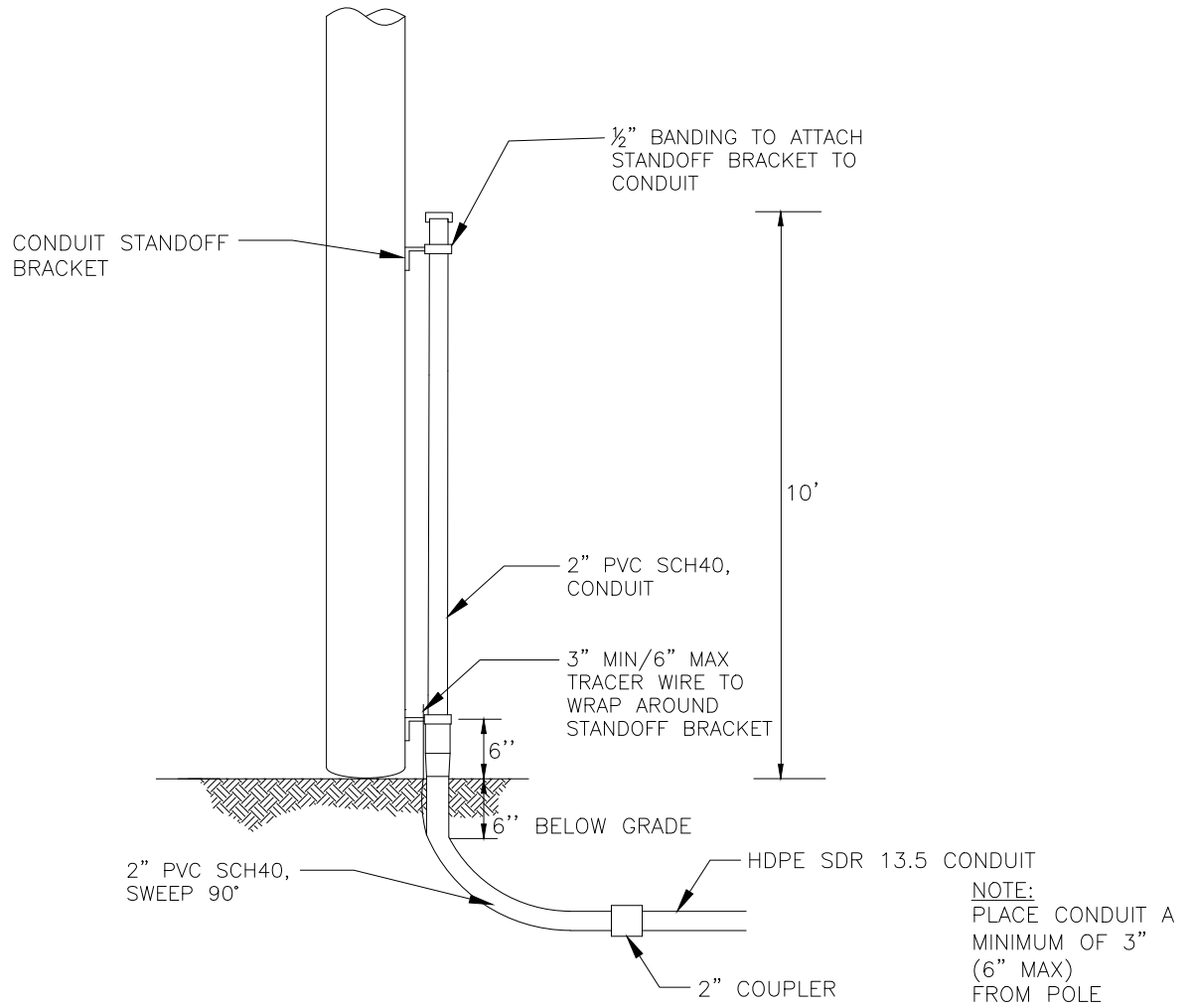

DESCRIPTION	QTY	MANUFACTURER (PREFERRED)	PART #
SCREW, LAG, 1/2" x 4-1/2"	10		
HDPE SDR 13.5 CONDUIT, VARIOUS SIZES	N/A		
2" PVC SCH40, RISER PIPE	1		
#12 TRACER WIRE	N/A		
2" PVC SCH40, SWEEP, 90 DEG	1		
CONDUIT STANDOFF BRACKET	VARIES		
CONDUIT STRAP KIT	VARIES		
2" COUPLER	1		



TYPICAL RISER  
CONDUIT  
WOOD POLE

(R2-W)

## CONCEPTUAL SIDE VIEW

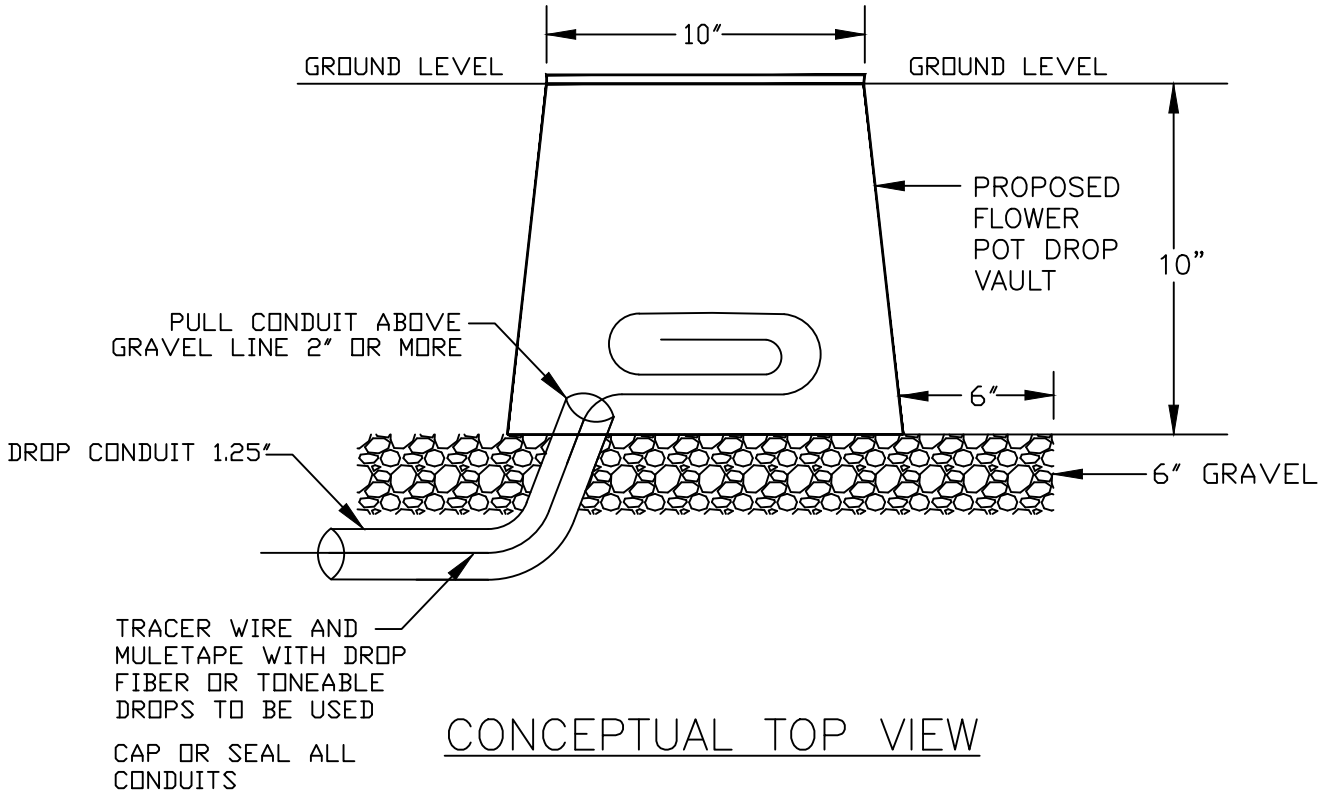

## CONCEPTUAL TOP VIEW

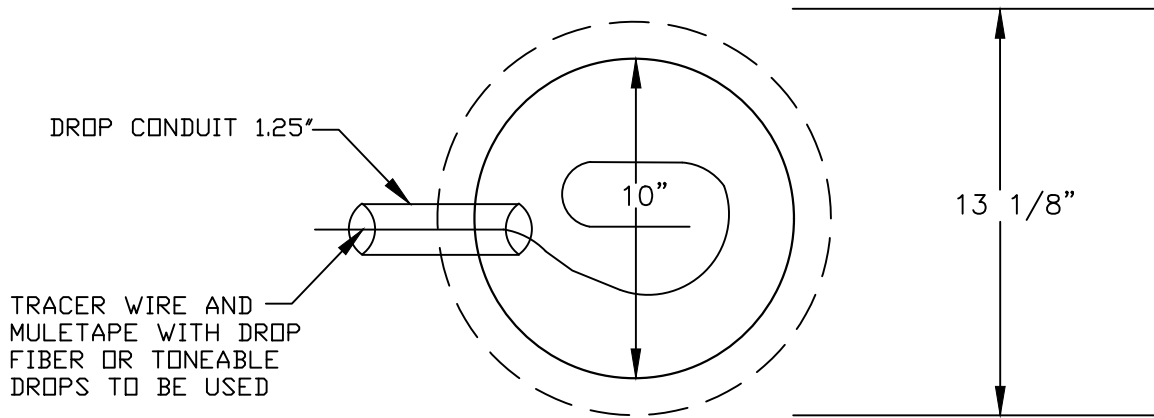

FLOWER POT

30"x48" PC UNIT, 2PC TIER 15/22  
 18", 24", and 36" HEIGHT



AMERICAN POLYMER COMPANY

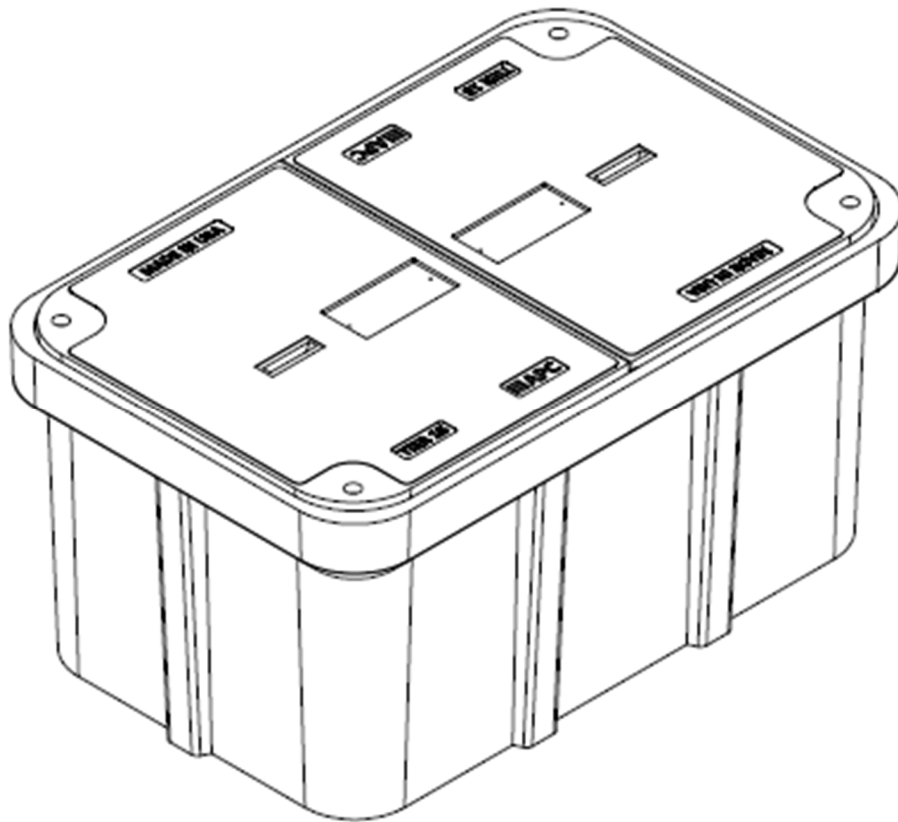

Description	Nominal Size	ANSI Tier	Part Number	Estimated Weight
PC Unit – TIER 15	30"x48"x18"	Tier 15	P304818HU15...	460 lbs.
PC Unit – TIER 22	30"x48"x18"	Tier 22	P304818HU22...	525 lbs.
PC Unit – TIER 15	30"x48"x24"	Tier 15	P304824HU15...	510 lbs.
PC Unit – TIER 22	30"x48"x24"	Tier 22	P304824HU22...	575 lbs.
PC Unit – TIER 15	30"x48"x36"	Tier 15	P304836HU15...	615 lbs.
PC Unit – TIER 22	30"x48"x36"	Tier 22	P304836HU22...	680 lbs.



# 30"x48" PC UNIT, 2PC TIER 15/22

18", 24", and 36" HEIGHT



AMERICAN POLYMER COMPANY

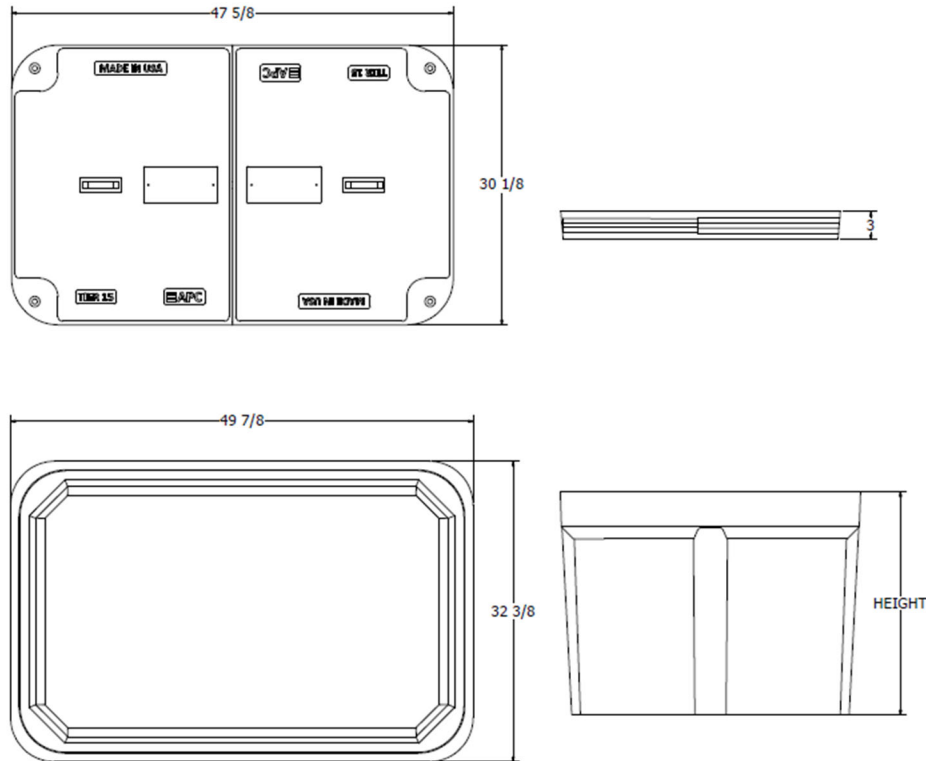

Components	Nominal Size	ANSI Tier	Part Number	Estimated Weight
Replacement Box	30"x48"x18"	Tier 22	P304818B22	185 lbs.
Replacement Box	30"x48"x24"	Tier 22	P304824B22	235 lbs.
Replacement Box	30"x48"x36"	Tier 22	P304836B22	340 lbs.
Replacement Lids - T15	30"x48" (half)	Tier 15	Various	150 lbs.
Replacement Lids - T22	30"x48" (half)	Tier 22	Various	170 lbs.

### Bolt options



Machine Thread



Auger Thread





24"x36" PC UNIT, TIER 15/22  
 18", 24", 30", and 36" HEIGHT



AMERICAN POLYMER COMPANY

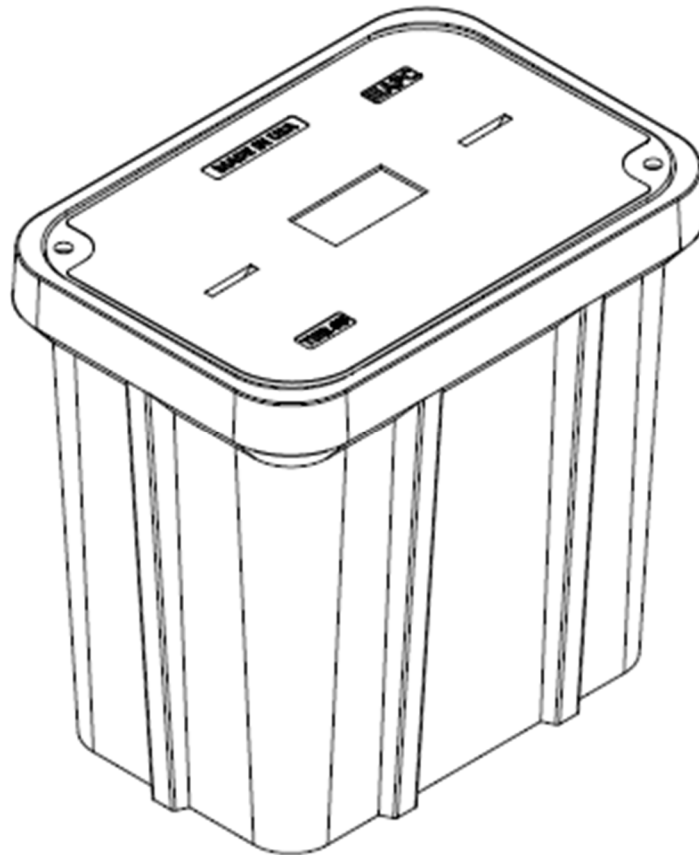

Description	Nominal Size	ANSI Tier	Part Number	Estimated Weight
PC Unit – TIER 15	24x36"x18"	Tier 15	P243618U15...	335 lbs.
PC Unit – TIER 22	24x36"x18"	Tier 22	P243618U22...	355 lbs.
PC Unit – TIER 15	24x36"x24"	Tier 15	P243624U15...	365 lbs.
PC Unit – TIER 22	24x36"x24"	Tier 22	P243624U22...	385 lbs.
PC Unit – TIER 15	24x36"x30"	Tier 15	P243630U15...	395 lbs.
PC Unit – TIER 22	24x36"x30"	Tier 22	P243630U22...	415 lbs.
PC Unit – TIER 15	24x36"x36"	Tier 15	P243636U15...	425 lbs.
PC Unit – TIER 22	24x36"x36"	Tier 22	P243636U22...	445 lbs.



# 24"x36" PC UNIT, TIER 15/22

18", 24", 30", and 36" HEIGHT



AMERICAN POLYMER COMPANY

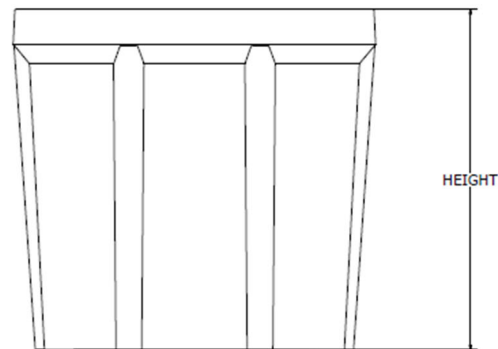
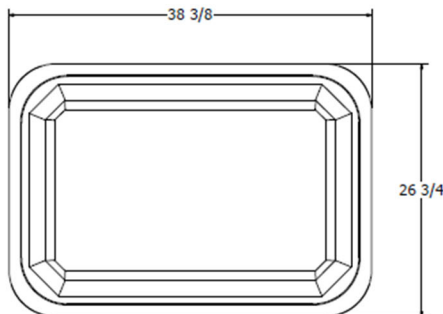
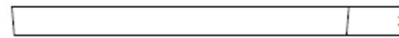
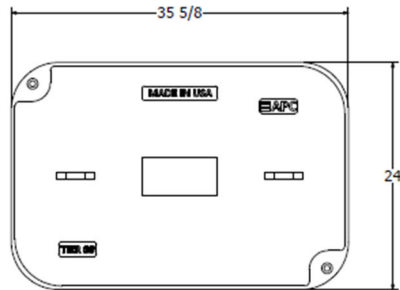

Components	Nominal Size	ANSI Tier	Part Number	Estimated Weight
Replacement Box	24"x36"x18"	Tier 22	P243618B22	165 lbs.
Replacement Box	24"x36"x24"	Tier 22	P243624B22	195 lbs.
Replacement Box	24"x36"x30"	Tier 22	P243630B22	225 lbs.
Replacement Box	24"x36"x36"	Tier 22	P243636B22	255 lbs.
Replacement Lids - T15	24"x36"	Tier 15	Various	170 lbs.
Replacement Lids - T22	24"x36"	Tier 22	Various	190 lbs.

### Bolt options

Hex Head



Machine Thread



Penta Head



Auger Thread



17"x30" PC UNIT, TIER 15/22

12", 18", 24", and 30" HEIGHT



AMERICAN POLYMER COMPANY

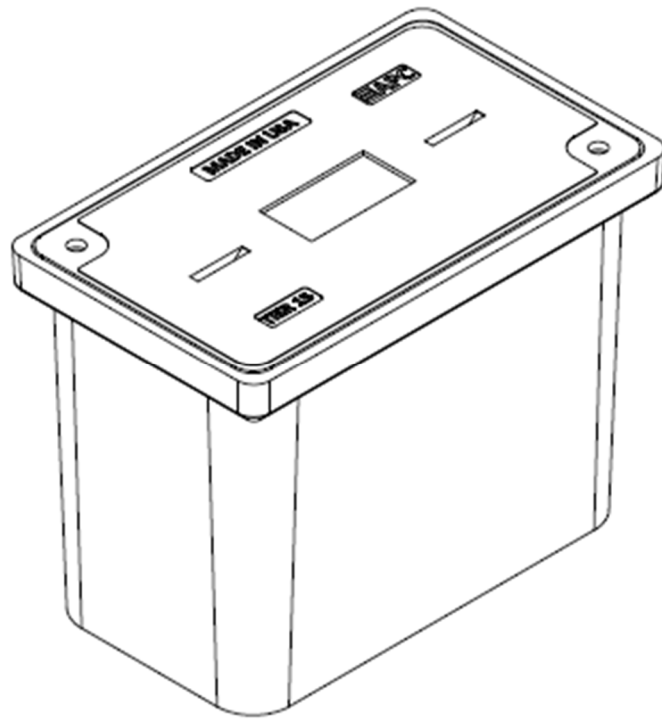

Description	Nominal Size	ANSI Tier	Part Number	Estimated Weight
PC Unit – TIER 15	17"x30"x12"	Tier 15	P173012U15...	138 lbs.
PC Unit – TIER 22	17"x30"x12"	Tier 22	P173012U22...	147 lbs.
PC Unit – TIER 15	17"x30"x18"	Tier 15	P173018U15...	172 lbs.
PC Unit – TIER 22	17"x30"x18"	Tier 22	P173018U22...	181 lbs.
PC Unit – TIER 15	17"x30"x24"	Tier 15	P173024U15...	192 lbs.
PC Unit – TIER 22	17"x30"x24"	Tier 22	P173024U22...	201 lbs.
PC Unit – TIER 15	17"x30"x30"	Tier 15	P173030U15...	217 lbs.
PC Unit – TIER 22	17"x30"x30"	Tier 22	P173030U22...	226 lbs.



# 17"x30" PC UNIT, TIER 15/22

12", 18", 24", and 30" HEIGHT



AMERICAN POLYMER COMPANY

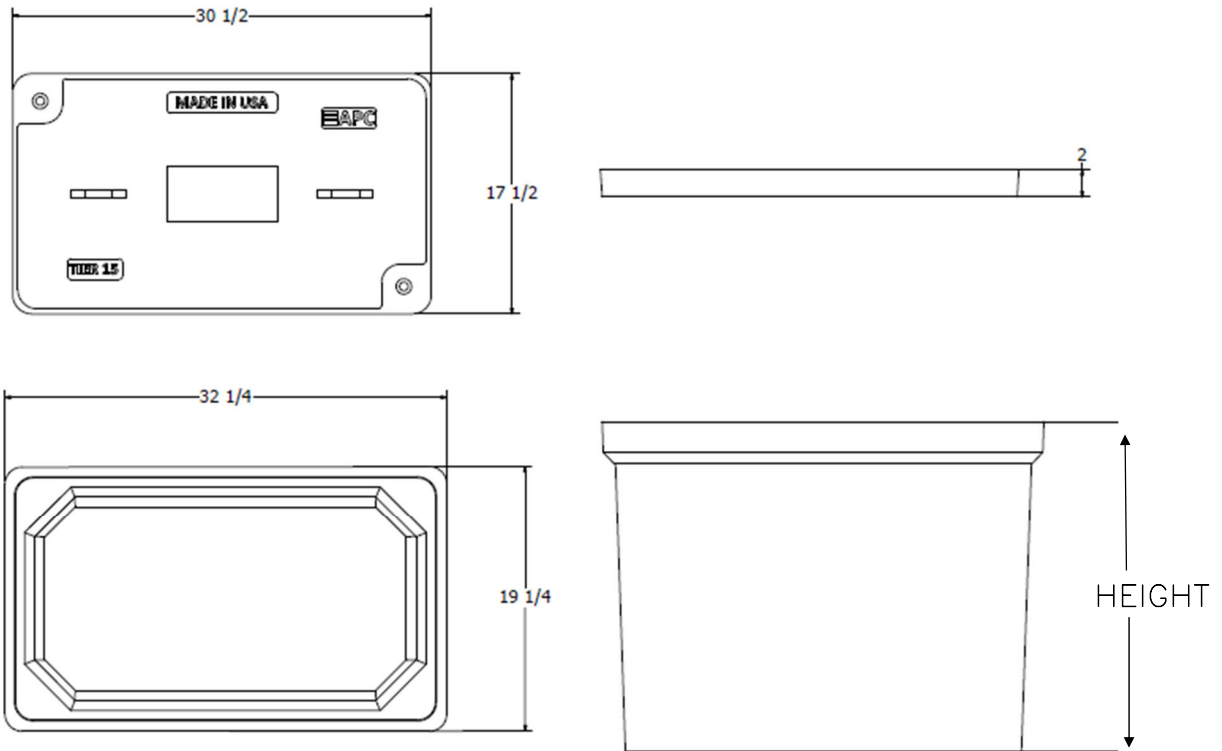

Components	Nominal Size	ANSI Tier	Part Number	Estimated Weight
Replacement Box	17"x30"x12"	Tier 22	P173012B22	66 lbs.
Replacement Box	17"x30"x18"	Tier 22	P173018B22	100 lbs.
Replacement Box	17"x30"x24"	Tier 22	P173024B22	120 lbs.
Replacement Box	17"x30"x30"	Tier 22	P173030B22	145 lbs.
Replacement Lids – T15	17"x30"	Tier 15	Various	72 lbs.
Replacement Lids – T22	17"x30"	Tier 22	Various	81 lbs.

### Bolt options



Machine Thread



Auger Thread



33"x60" PC UNIT, 2PC TIER 15/22  
36" HEIGHT



AMERICAN POLYMER COMPANY

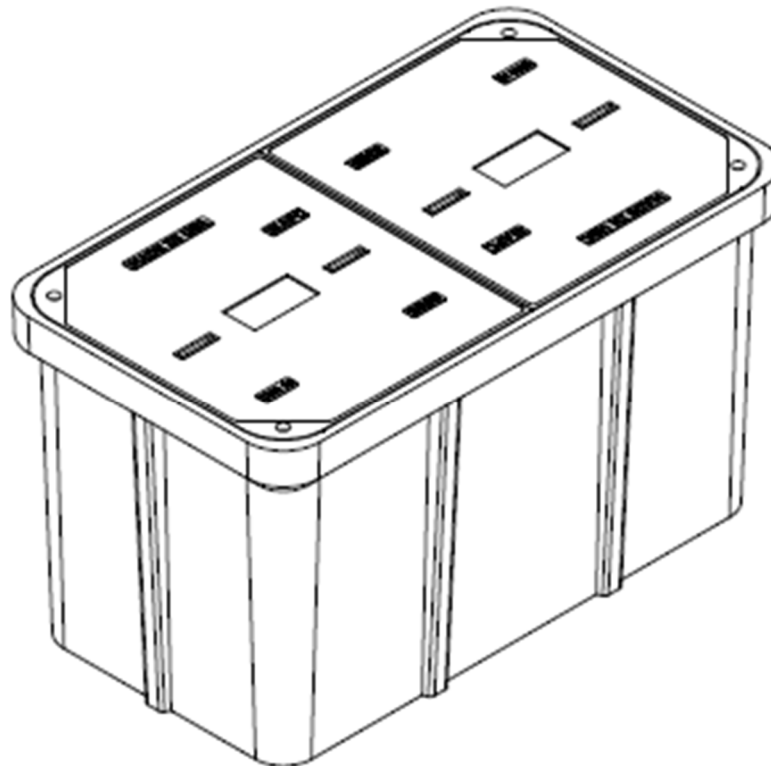

Description	Nominal Size	ANSI Tier	Part Number	Estimated Weight
PC Unit - TIER 15	33"x60"x36"	Tier 15	P336036U15...	930 lbs.
PC Unit - TIER 22	33"x60"x36"	Tier 22	P336036U22...	1030 lbs.



# 33"x60" PC UNIT, 2PC TIER 15/22

## 36" HEIGHT



AMERICAN POLYMER COMPANY

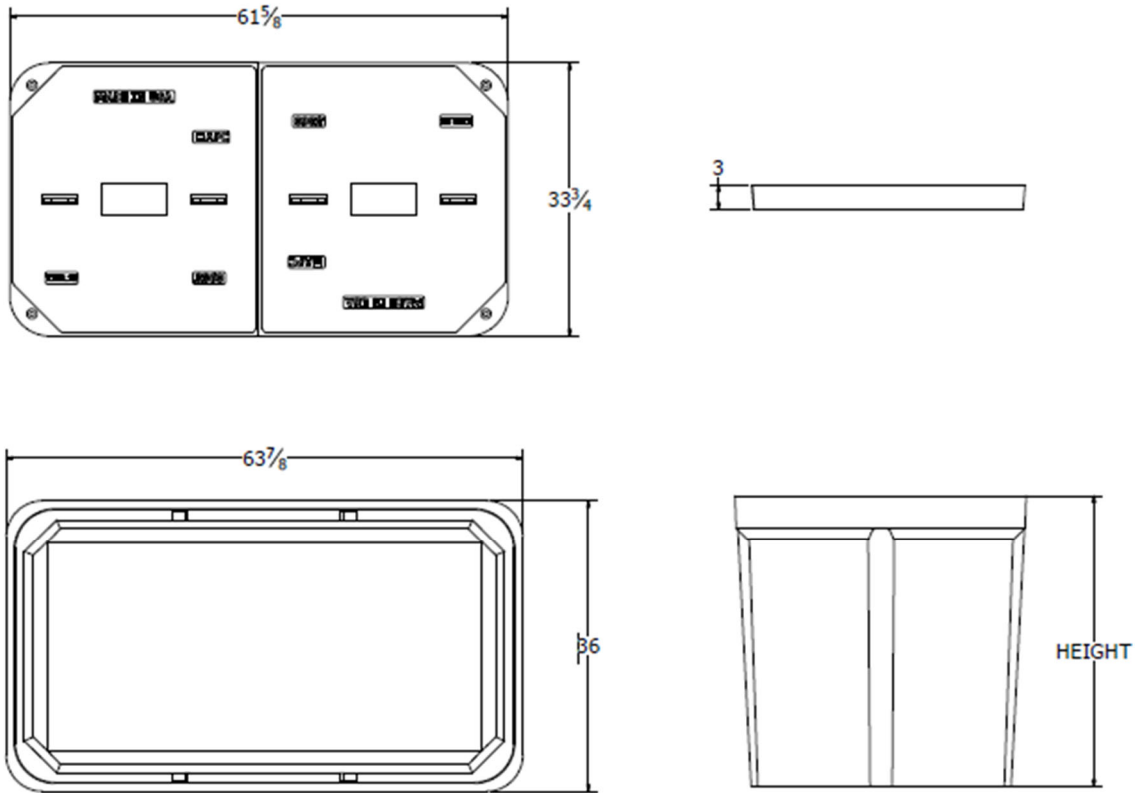

Components	Nominal Size	ANSI Tier	Part Number	Estimated Weight
Replacement Box	33"x60"x36"	Tier 22	P336036B22	530 lbs.
Replacement Lids - T15	33"x60" (half)	Tier 15	Various	200 lbs.
Replacement Lids - T22	33"x60" (half)	Tier 22	Various	250 lbs.

### Bolt options

Hex Head



Machine Thread



Penta Head



Auger Thread





Speed (MPH) Prior To Road Work	SIGN SPACING, FT.		MUTCD Must be Approved by an Engineer				
	Non-Divided Highways	Divided Highways	BUFFER SPACE, FT.	TAPER LENGTH, FT.	CHANNELIZING SPACING, FT.		
	Length	Shoulder (10 ft. Width)	Lane (12 ft. Width)	Through Taper	Through Buffer/Work Area		
0-35	200	200	250	70	245	35	50
40-45	350	500	360	150	540	40	80
50-55	500	1000	495	185	660	50	100
60-70	SA-1000, SB-1500, SC-2640		730	235	840	60	120
Urban Low Speed - 100 FT							

APPROVED/ACCEPTED BY:  
ENGINEER, OWNER, or PRIME CONTRACTOR  
 Check for Notice to Proceed.  
BLN01a-F01\_E Tamarack Trl -TCP1

Signature: \_\_\_\_\_

Company: \_\_\_\_\_

**Road Runner**  
Safety Services, Inc.

Date: 2/13/2023 Project: BLN01a-F01\_E Tamarack Trl -TCP1 :  
: Traffic Control Suggestion For: AEG :  
By: Road Runner Safety Services, Inc. : Nathan

Comments:  
Drawing not to scale. Traffic control plan must be approved by an engineer. This is a suggestion only. Road Runners Safety Services, Inc. has no liability for this suggested traffic control plan. Actual placement and spacing of all traffic control devices will depend on field conditions and must conform to MUTCD standards.





Spacing Charts Based on MUTCD		Must be Approved by an Engineer					
Speed (MPH) Prior To Road Work	SIGN SPACING, FT.		BUFFER SPACE, FT.	TAPER LENGTH, FT.		CHANNELIZING SPACING, FT.	
	Non-Divided Highways	Divided Highways	Length	Shoulder (10 ft Width)	Lane (12 ft Width)	Through Taper	Through Buffer/Work Area
0-35	200	200	250	70	245	35	50
40-45	350	500	360	150	540	40	80
50-55	500	1000	495	185	660	50	100
60-70	SA-1000, SB-1500, SC-2640 Urban Low Speed - 100 FT		730	235	840	60	120

APPROVED/ACCEPTED BY:  
ENGINEER, OWNER, or PRIME CONTRACTOR  
 Check for Notice to Proceed.  
BLN01a-F01\_E Tamarack Trl -TCP1a

Signature: \_\_\_\_\_

Company: \_\_\_\_\_



Date: 2/13/2023 Project: BLN01a-F01\_E Tamarack Trl -TCP1a :  
: Traffic Control Suggestion For: AEG :  
By: Road Runner Safety Services, Inc. : Nathan

Comments:  
Drawing not to scale. Traffic control plan must be approved by an engineer. This is a suggestion only. Road Runners Safety Services, Inc. has no liability for this suggested traffic control plan. Actual placement and spacing of all traffic control devices will depend on field conditions and must conform to MUTCD standards.

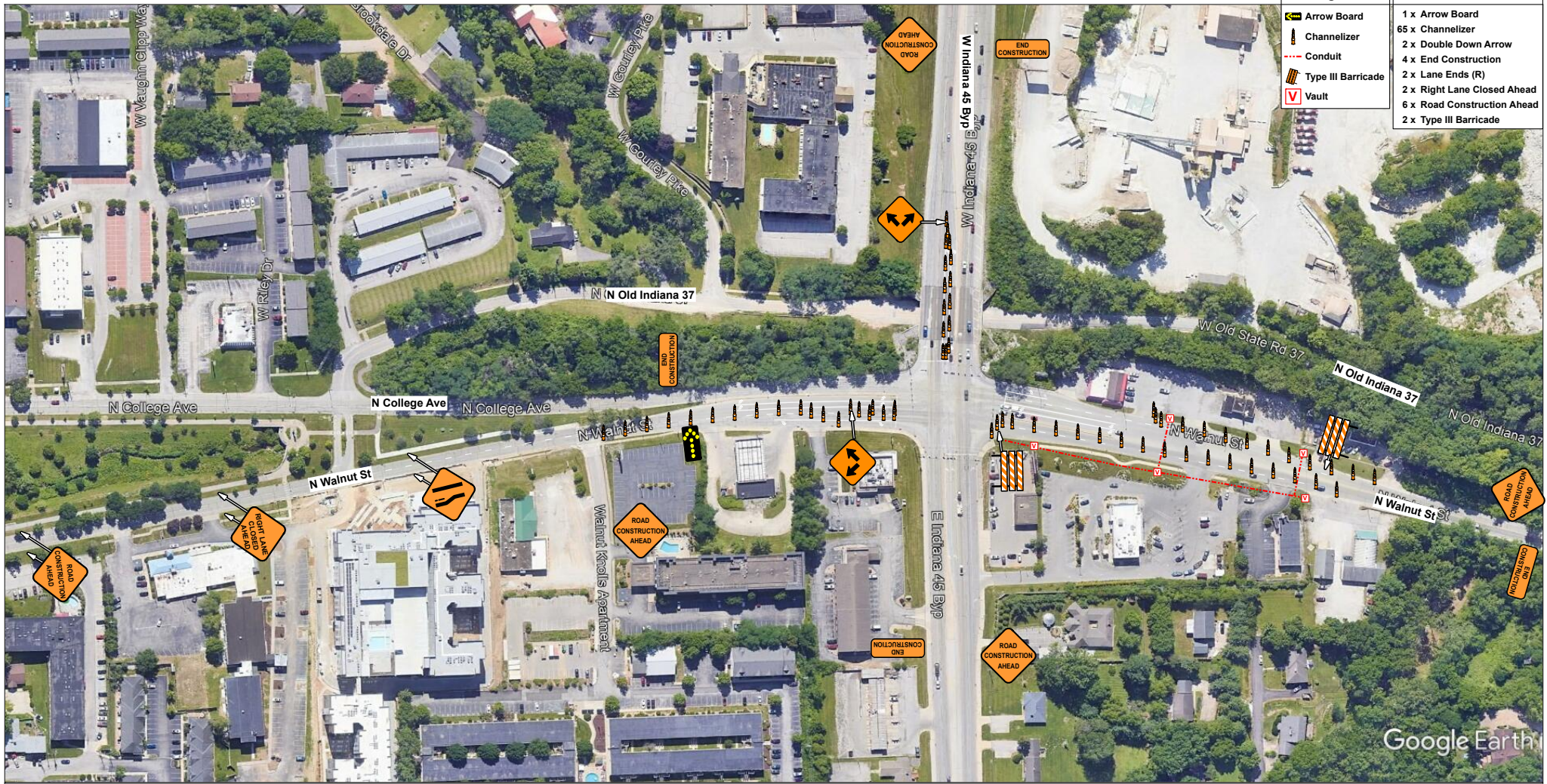

Google Earth



Speed (MPH) Prior To Road Work	SIGN SPACING, FT.		Must be Approved by an Engineer				
	Non-Divided Highways	Divided Highways	BUFFER SPACE, FT.	TAPER LENGTH, FT.	CHANNELIZING SPACING, FT.		
	Length	Shoulder (10 ft. Width)	Lane (12 ft. Width)	Through Taper	Through Buffer/Work Area		
0-35	200	200	250	70	245	35	50
40-45	350	500	360	150	540	40	80
50-55	500	1000	495	185	660	50	100
60-70	SA-1000, SB-1500, SC-2640		730	235	840	60	120
Urban Low Speed - 100 FT							

APPROVED/ACCEPTED BY:  
ENGINEER, OWNER, or PRIME CONTRACTOR  
 Check for Notice to Proceed.  
**BLN01a-F01\_E Tamarack Trl -TCP2**

Signature: \_\_\_\_\_

Company: \_\_\_\_\_



Date: 2/13/2023 Project: BLN01a-F01\_E Tamarack Trl -TCP2 :  
: Traffic Control Suggestion For: AEG :  
By: Road Runner Safety Services, Inc. : Nathan

Comments:  
Drawing not to scale. Traffic control plan must be approved by an engineer. This is a suggestion only. Road Runners Safety Services, Inc. has no liability for this suggested traffic control plan. Actual placement and spacing of all traffic control devices will depend on field conditions and must conform to MUTCD standards.



Legend	
	ADA Barricade
	Channelizer
	Conduit
	Flagger (Person)
	Sign
	Vault
	Work Area

Sheet 1

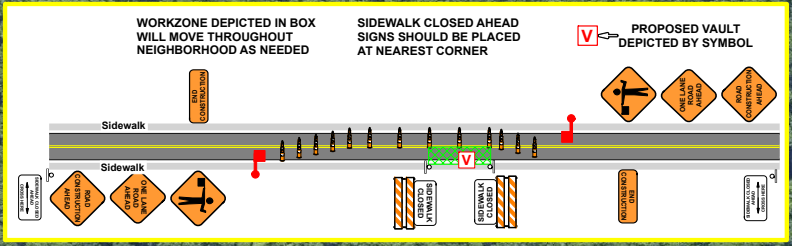



Spacing Charts Based on MUTCD		Must be Approved by an Engineer					
Speed (MPH) Prior To Road Work	SIGN SPACING, FT.		BUFFER SPACE, FT.	TAPER LENGTH, FT.	CHANNELIZING SPACING, FT.		
	Non-Divided Highways	Divided Highways	Length	Shoulder (10 ft. Width)	Lane (12 ft. Width)	Through Taper	Through Buffer/Work Area
0-35	200	200	250	70	245	35	50
40-45	350	500	360	150	540	40	80
50-55	500	1000	495	185	660	50	100
60-70	SA-1000, SB-1500, SC-2640		730	235	840	60	120
Urban Low Speed - 100 FT							

APPROVED/ACCEPTED BY:  
ENGINEER, OWNER, or PRIME CONTRACTOR  
 Check for Notice to Proceed.  
**BLN01a-F01\_E Tamarack Trl -TCP3**

Signature: \_\_\_\_\_

Company: \_\_\_\_\_

**Road Runner**  
Safety Services, Inc.

Date: 2/13/2023 Project: BLN01a-F01\_E Tamarack Trl -TCP3 :  
: Traffic Control Suggestion For: AEG :  
By: Road Runner Safety Services, Inc. : Nathan

Comments:  
Drawing not to scale. Traffic control plan must be approved by an engineer. This is a suggestion only. Road Runners Safety Services, Inc. has no liability for this suggested traffic control plan. Actual placement and spacing of all traffic control devices will depend on field conditions and must conform to MUTCD standards.







# CITY OF BLOOMINGTON RIGHT-OF-WAY USE PERMIT APPLICATION

401 N Morton Street, Suite 130  
P.O. Box 100  
Bloomington, IN 47402

Phone: (812) 349-3913  
Fax: (812) 349-3520  
Email:  
engineering@bloomington.in.gov

ROW EXCAVATION  ROW USE

ADDRESS OF ROW ACTIVITY: E Tamarack Trl

<b>A. APPLICANT/AGENT INFORMATION:</b>		<b>D. TRAFFIC CONTROL DEVICES*:</b>	
APPLICANT NAME: <u>Bret Simons</u>		<input checked="" type="checkbox"/> CONES <input type="checkbox"/> ARROWBOARD	
E-MAIL: <u>bret.simons@aeg.cc</u>		<input type="checkbox"/> LIGHTED BARRELS <input checked="" type="checkbox"/> TYPE 3 BARRICADES	
COMPANY: <u>Atlantic Engineering Group</u>		<input checked="" type="checkbox"/> FLAGGERS <input type="checkbox"/> BPD OFFICER	
ADDRESS: <u>P.O. Box 349</u>		*PROVIDING MUTCD COMPLIANT TEMPORARY TRAFFIC CONTROL DEVICES AND MAINTENANCE OF TRAFFIC (MOT) PLAN IS YOUR RESPONSIBILITY AND REQUIRED. See page 3 for additional MOT resources; the graph paper can be used for your MOT site plan if needed or you can submit a separate sheet	
CITY, STATE, ZIP: <u>Buford, GA 30515</u>			
24-HR EMERGENCY CONTACT NAME: <u>(706)654-2298</u>		<b>E. METERED PARKING SPACES NEEDED: <input type="checkbox"/> Y <input type="checkbox"/> N</b>	
24-HR CONTACT PHONE #: _____		IT IS THE RESPONSIBILITY OF THE APPLICANT TO RESERVE PARKING METER(S) APPLICATION LOCATED: <a href="https://bloomington.in.gov/transportation/parking/moving">https://bloomington.in.gov/transportation/parking/moving</a> OR CONTACT PARKING SERVICES WITH QUESTIONS AT (812)349-3436	
INSURANCE #*: <u>TB5-691-473497-082</u> COMPANY: <u>ACORD</u>		<b>F. IS THIS A <input type="checkbox"/> CBU* <input type="checkbox"/> COUNTY* <input type="checkbox"/> IU* <input type="checkbox"/> NP* PROJECT?</b>	
BOND #*: <u>1160465</u> COMPANY: <u>LEXON</u>		PROJECT NAME: <u>BLN01a-F01 E Tamarack Trl</u>	
*INSURANCE & BOND MUST BE ON FILE WITH THE CITY BEFORE PERMIT WILL BE ISSUED		PROJECT #: <u>BLN01a-F01 E Tamarack Trl</u>	
<b>**SUBCONTRACTOR INFORMATION**</b>		PROJECT MGR.: <u>Lex Mullins</u>	
(LIST ALL COMPANIES WORKING UNDER PRIMARY CONTRACTOR PERMIT)		PROJECT MGR. #: <u>215-847-8819</u>	
COMPANY NAME: _____		*CBU = CITY OF BLOOMINGTON UTILITIES *COUNTY = MONROE COUNTY	
<b>B. WORK DESCRIPTION:</b>		*IU = INDIANA UNIVERSITY *NP = NOT-FOR-PROFIT AGENCY	
<input type="checkbox"/> POD/DUMPSTER <input type="checkbox"/> CRANE <input type="checkbox"/> SCAFFOLDING <input checked="" type="checkbox"/> CONSTRUCTION USE*		<b>G. EXCAVATIONS:</b>	
(EXPLAIN): <u>Excavation</u>		SQ FT OF PAVEMENT* EXCAVATIONS: <u>N/A</u>	
*EXCAVATION, LONG TERM USE FOR STORAGE OF MATERIAL/EQUIPMENT/WALKAROUND		*PAVEMENT INCLUDES: IN OR UNDER CONCRETE, OR ASPHALT INCLUDING CURBS	
<b>C. RIGHT OF WAY TO BE USED/CLOSED:</b>		SQ FT OF NON-PAVEMENT* EXCAVATIONS: <u>847.26 Sq Ft</u>	
STREET NAME 1: <u>E Tamarack Trl</u>		*DIRT, GRASS, GRAVEL, LANDSCAPE AREA OR OTHER UNPAVED SURFACE	
1ST INTERSECTING STREET NAME: _____		LINEAL FT OF BORE*: <u>41,225 Lineal Ft</u>	
2ND INTERSECTING STREET NAME: _____		*BORE PITS SHALL BE CALCULATED AS SQ FT EXCAVATIONS	
<input type="checkbox"/> ROAD CLOSURE <input checked="" type="checkbox"/> LANE CLOSURE 1 <input checked="" type="checkbox"/> 2 <input type="checkbox"/> 3 <input type="checkbox"/>		# OF POLE INSTALLATIONS/REMOVAL: <u>N/A</u>	
<input checked="" type="checkbox"/> SIDEWALK* <input type="checkbox"/> BIKE LANE <input type="checkbox"/> OTHER		SQ FT OF SIDEWALK RECONSTRUCTION*: <u>N/A</u>	
TRANSIT STOP? <input type="checkbox"/> Y <input type="checkbox"/> N PARKING LANE(S)** <input type="checkbox"/> Y <input type="checkbox"/> N **NON-METERED		*CONCRETE OR ASPHALT SIDEWALK/PATH BEING IMPROVED/REPLACED	
START DATE: <u>Mar 3rd</u> END DATE: _____ # OF DAYS*: <u>30</u>		SQ FT OF SIDEWALK NEW CONSTRUCTION*: <u>N/A</u>	
STREET NAME 2: _____		*CONCRETE OR ASPHALT SIDEWALK/PATH THAT IS NEW INFRASTRUCTURE	
1ST INTERSECTING STREET NAME: _____		#RESIDENTIAL DRIVEWAY INSTALLATION: <u>N/A</u>	
2ND INTERSECTING STREET NAME: _____		 <p>TO SUBMIT A LOCATE REQUEST 24 HRS A DAY, 7 DAYS A WEEK CALL 811 OR 800-382-5544 CALL 2 WORKING DAYS BEFORE YOU DIG. IT'S THE LAW.</p>	
<input type="checkbox"/> ROAD CLOSURE <input type="checkbox"/> LANE CLOSURE 1 <input type="checkbox"/> 2 <input type="checkbox"/> 3 <input type="checkbox"/>			
<input type="checkbox"/> SIDEWALK* <input type="checkbox"/> BIKE LANE <input type="checkbox"/> OTHER		<b>H. INDEMNIFICATION AGREEMENT:</b>	
TRANSIT STOP? <input type="checkbox"/> Y <input type="checkbox"/> N PARKING LANE(S)** <input type="checkbox"/> Y <input type="checkbox"/> N **NON-METERED		The petitioner/applicant hereby agrees to hold harmless, defend and to indemnify the City of Bloomington from or against all claims, action, damages and expenses, including but not limited to reasonable attorney's fees or any alleged injury and/or death to any person or damage to any property arising, or alleged to have arisen out of any act of commission or omission on the part of the petitioner/applicant, his/her heirs, successors, or assigns regardless of whether such acts are the direct or indirect result of the public right-of-way use pursuant to this permit grant.	
START DATE: _____ END DATE: _____ # OF DAYS*: _____		I AFFIRM, UNDER THE PENALTIES FOR PERJURY, THAT THE FOREGOING REPRESENTATIONS ARE TRUE.	
*SIDEWALK CLOSURES FOR A PERIOD OR PERIODS TOTALING 24HRS OR MORE SHALL INSTALL A WALKAROUND UNLESS OTHERWISE APPROVED DURING REVIEW		PRINT NAME: <u>Bret Simons</u>	
<b>STANDARD CLOSURE HOURS MON-FRI*: 9:00 AM - 3:00 PM &amp; 6:00 PM - 9:00 PM</b>		SIGNATURE: <u>Bret Simons</u>	
STANDARD CLOSURE HOURS <input checked="" type="checkbox"/> *NON-STANDARD CLOSURE HOURS <input type="checkbox"/>		DATE: <u>2/10/2023</u>	
REQUESTED CLOSURE HOURS: _____ AM - _____ PM			
*non-standard hours may not be allowed near schools, on arterials, or other circumstances and are subject to approval during the permitting process			
BMC 14.09.040 allows work from 6 AM to 10 PM without violating the noise ordinance (7AM to 9PM for pneumatic hammers)			

For Administration Use Only (applicable to CLOSURE approval)

Approved By: \_\_\_\_\_  BPW  City Engineer  Director Date: \_\_\_\_\_

Staff Representative: \_\_\_\_\_ Phone#: \_\_\_\_\_ Date: \_\_\_\_\_

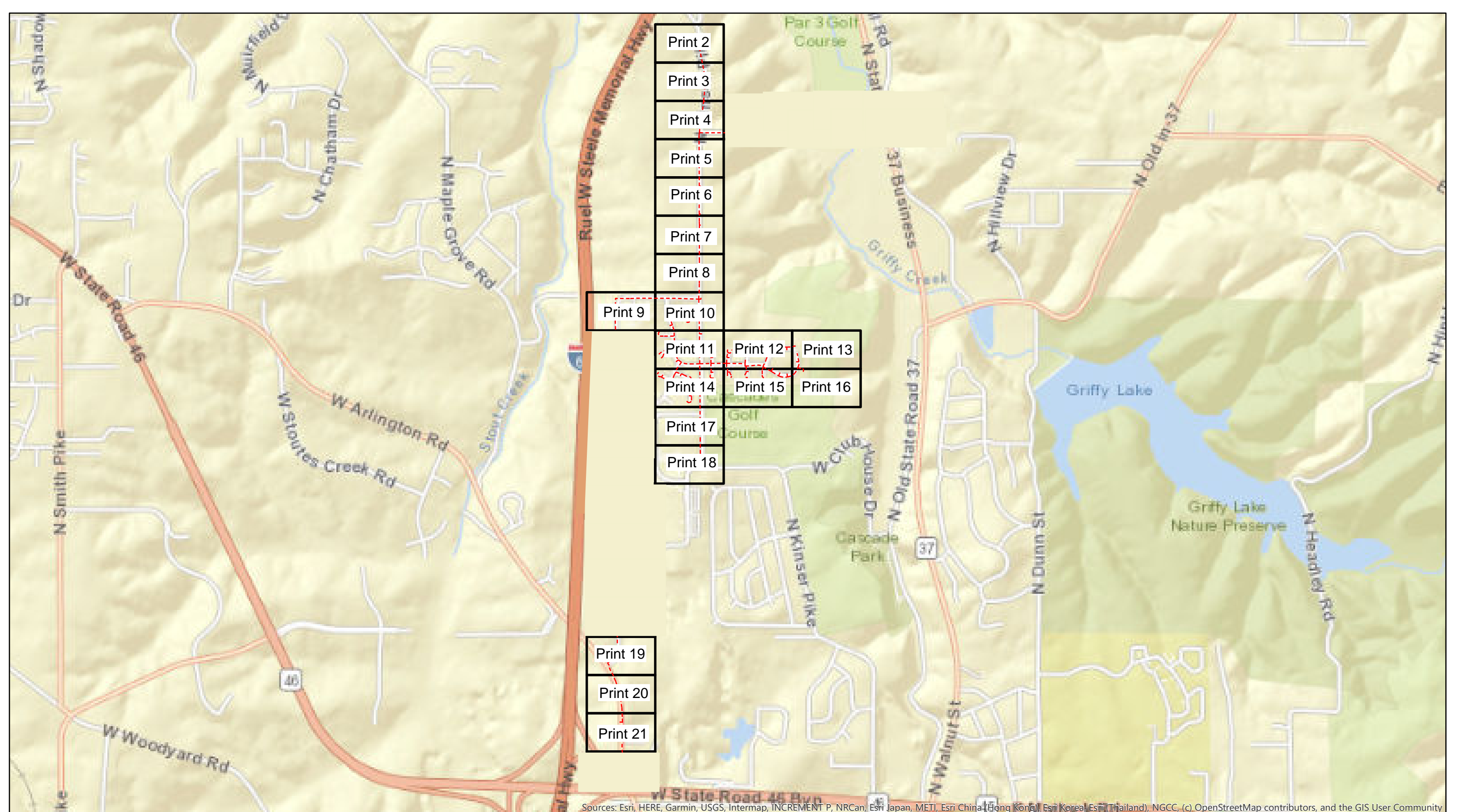

Sources: Esri, HERE, Garmin, USGS, Intermap, INCREMENT P, NRCan, Esri Japan, METI, Esri China (Hong Kong), Esri Korea, Esri (Thailand), NGCC, (c) OpenStreetMap contributors, and the GIS User Community



Legend BLN01a-F04\_Acuff Rd

- Overhead Strand
- ⋯ Conduit
- Grids

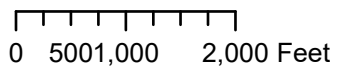

City of Bloomington, IN Permit:  
Design View

INI	BY	DATE	DESCRIPTION





4755  
N KINSER  
PIKE

Flowerpot

515'  
N Kinser PIKE



0 20 40 80 Feet

**Legend**

- Poles
- Vaults
- Overhead Strand
- Conduit
- Bloomington\_Parcels
- Risers
- Address
- Anchor
- Sidewalk
- Grids

All Flowerpots 12" DIA



City of Bloomington, IN Permit:  
Design View

INI	BY	DATE	DESCRIPTION



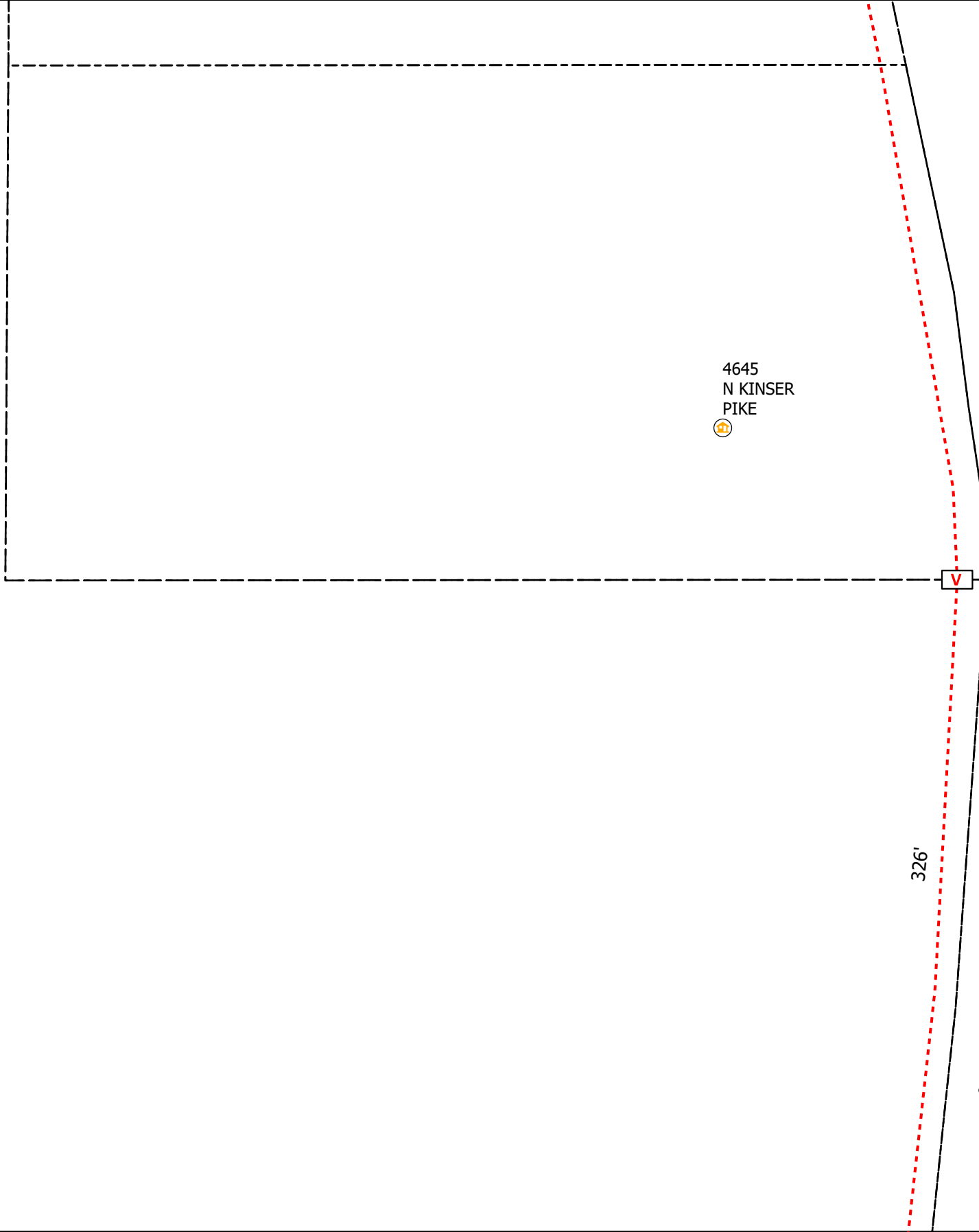

**Legend**

- Poles
- Risers
- Address
- Grids
- Bloomington\_Parcels
- Anchors
- Sidewalk
- Vaults
- Overhead Strand
- Conduit

All Flowerpots 12" DIA



City of Bloomington, IN Permit:  
Design View

INI	BY	DATE	DESCRIPTION



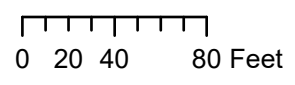
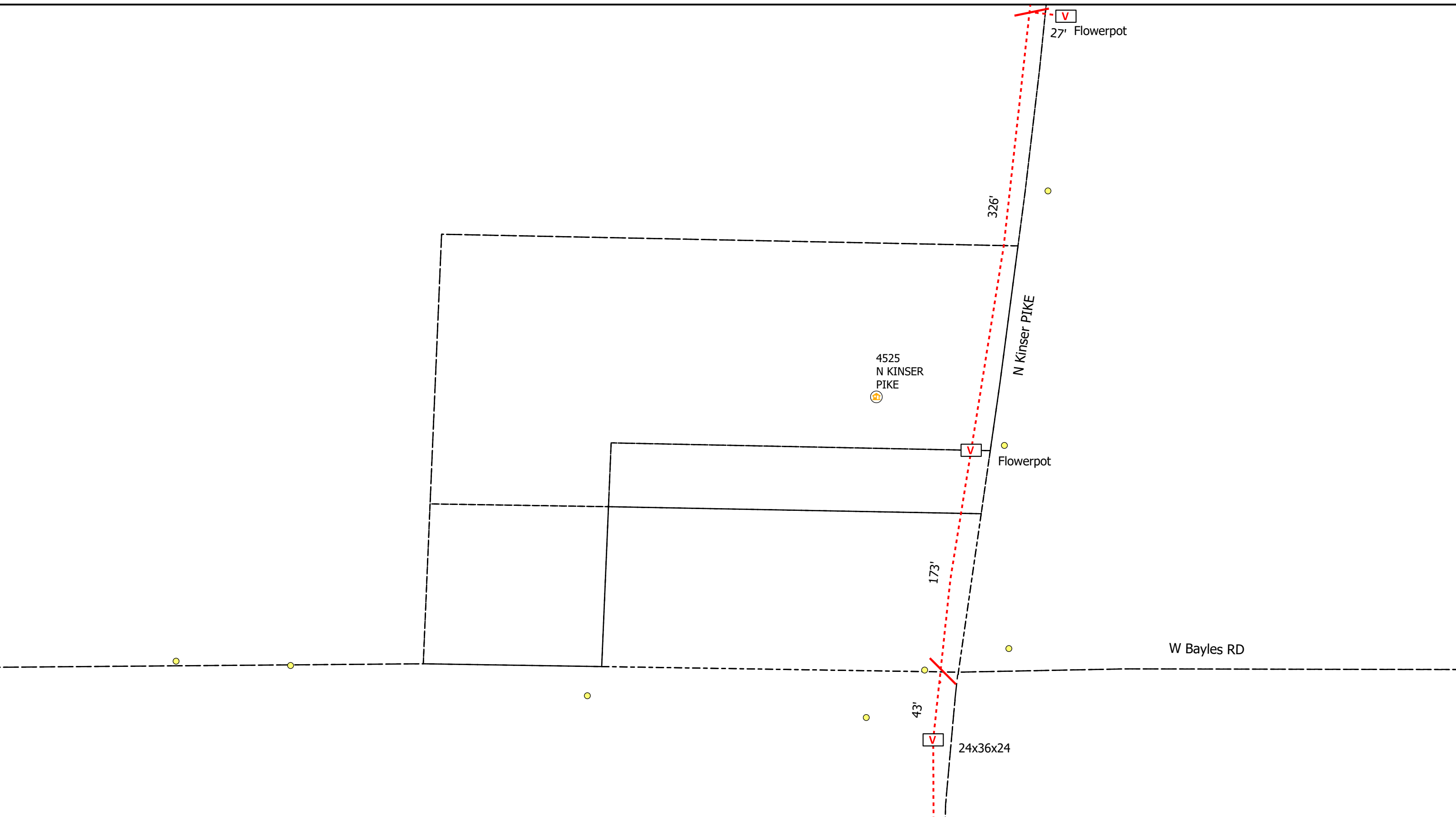

**Legend**

- Poles
- V Vaults
- Overhead Strand
- - - Conduit
- Bloomington\_Parcels
- R Risers
- A Address
- Y Anchor
- ← Sidewalk
- Grids

All Flowerpots 12" DIA



City of Bloomington, IN Permit:  
Design View

INI	BY	DATE	DESCRIPTION



4499  
N KINSER  
PIKE

801'  
N Kinser PIKE

4346  
N KINSER  
PIKE



0 20 40 80 Feet

**Legend**

- Poles
- Vaults
- Overhead Strand
- Conduit
- Bloomington\_Parcels
- Risers
- Address
- Anchor
- Sidewalk
- Grids

All Flowerpots 12" DIA



City of Bloomington, IN Permit:  
Design View

INI	BY	DATE	DESCRIPTION



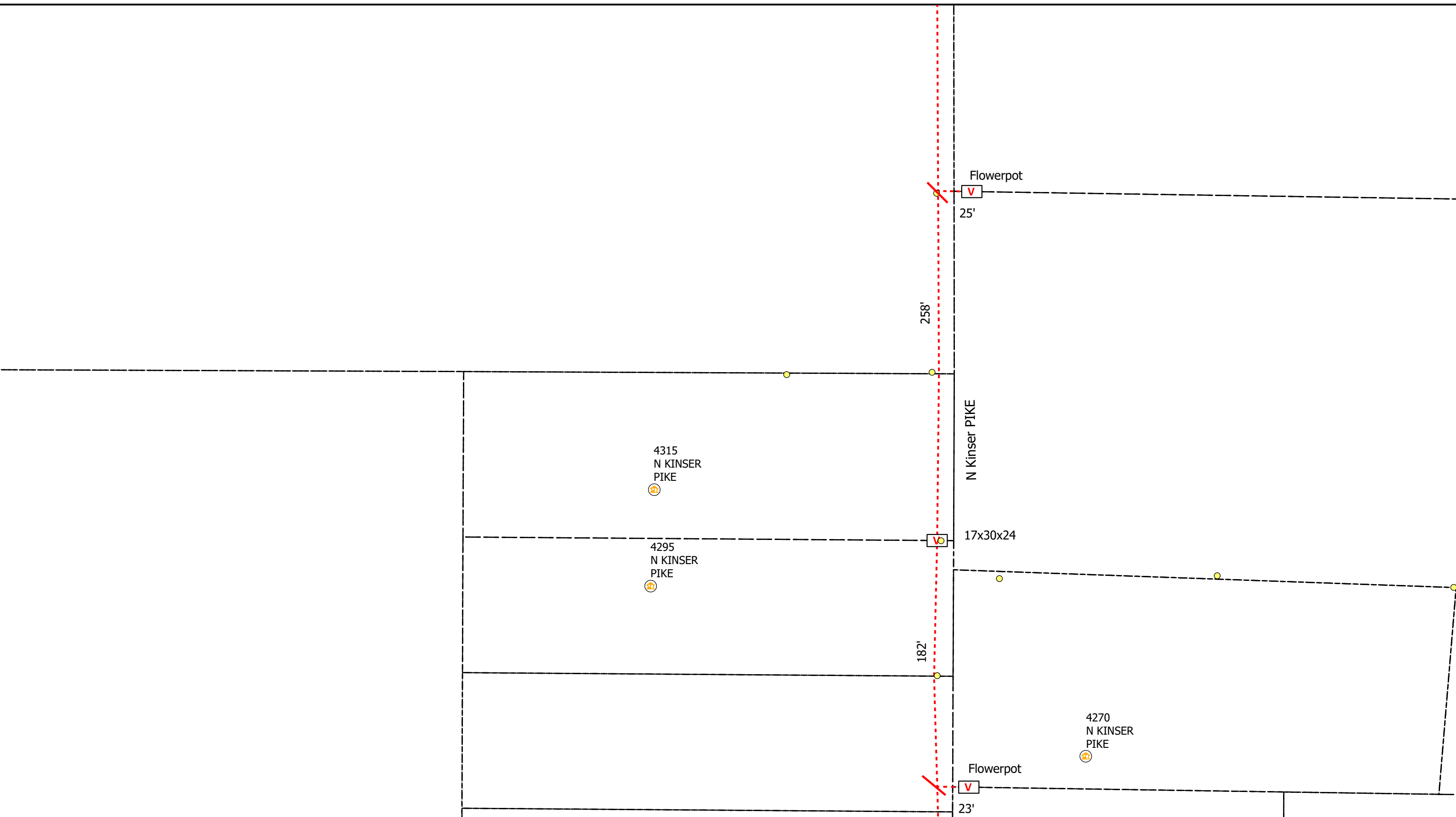

**Legend**

- Poles
- V Vaults
- Overhead Strand
- Conduit
- Bloomington\_Parcels
- R Risers
- A Address
- Y Anchor
- K Sidewalk
- Grids

All Flowerpots 12" DIA



City of Bloomington, IN Permit:  
Design View

INI	BY	DATE	DESCRIPTION

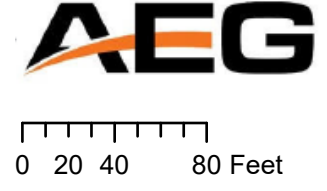



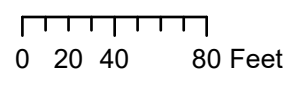
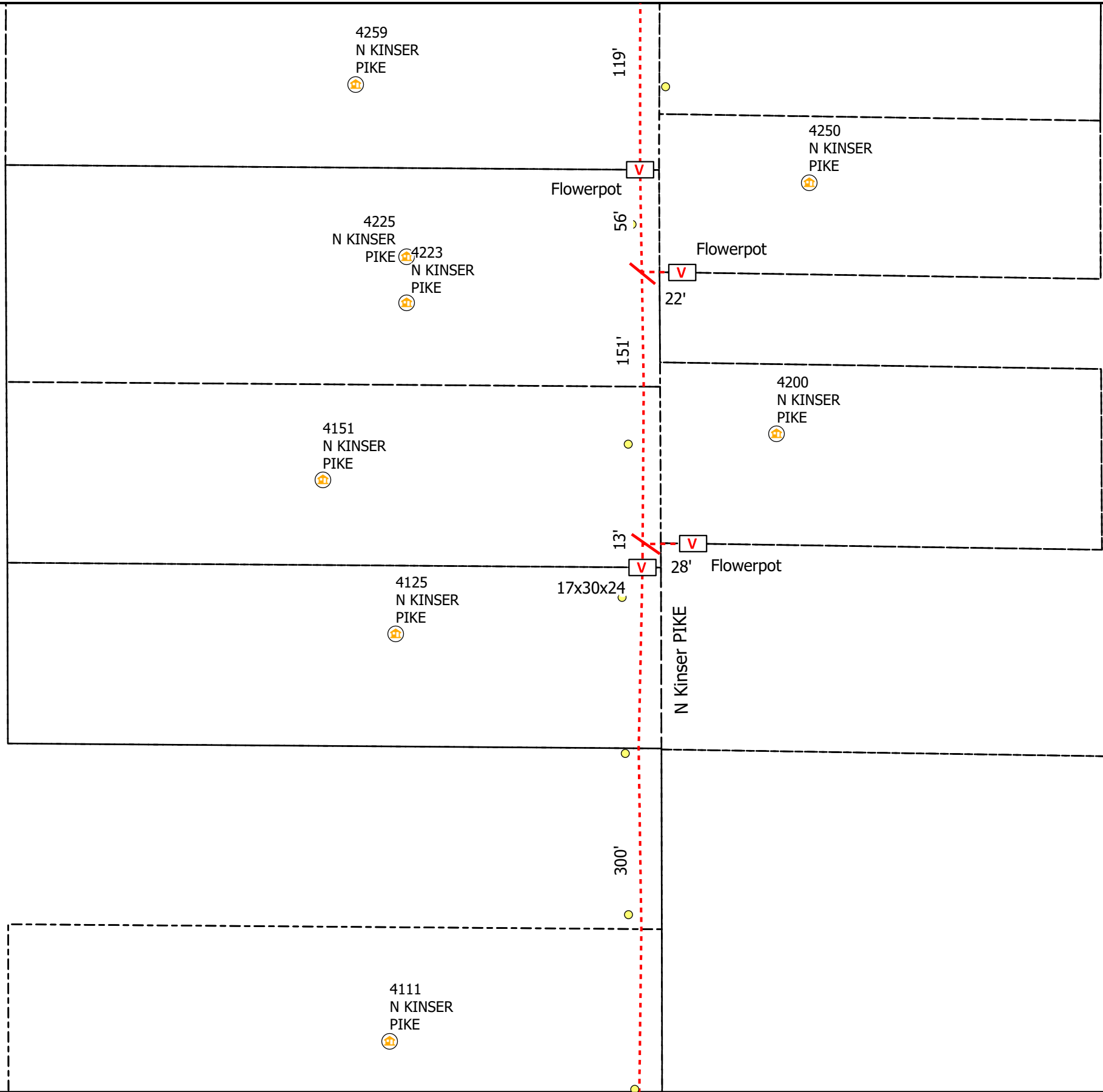

**Legend**

- Poles
- V Vaults
- Overhead Strand
- Conduit
- Bloomington\_Parcels
- R Risers
- A Address
- Y Anchor
- K Sidewalk
- Grids

All Flowerpots 12" DIA



City of Bloomington, IN Permit:  
Design View

INI	BY	DATE	DESCRIPTION



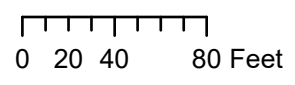
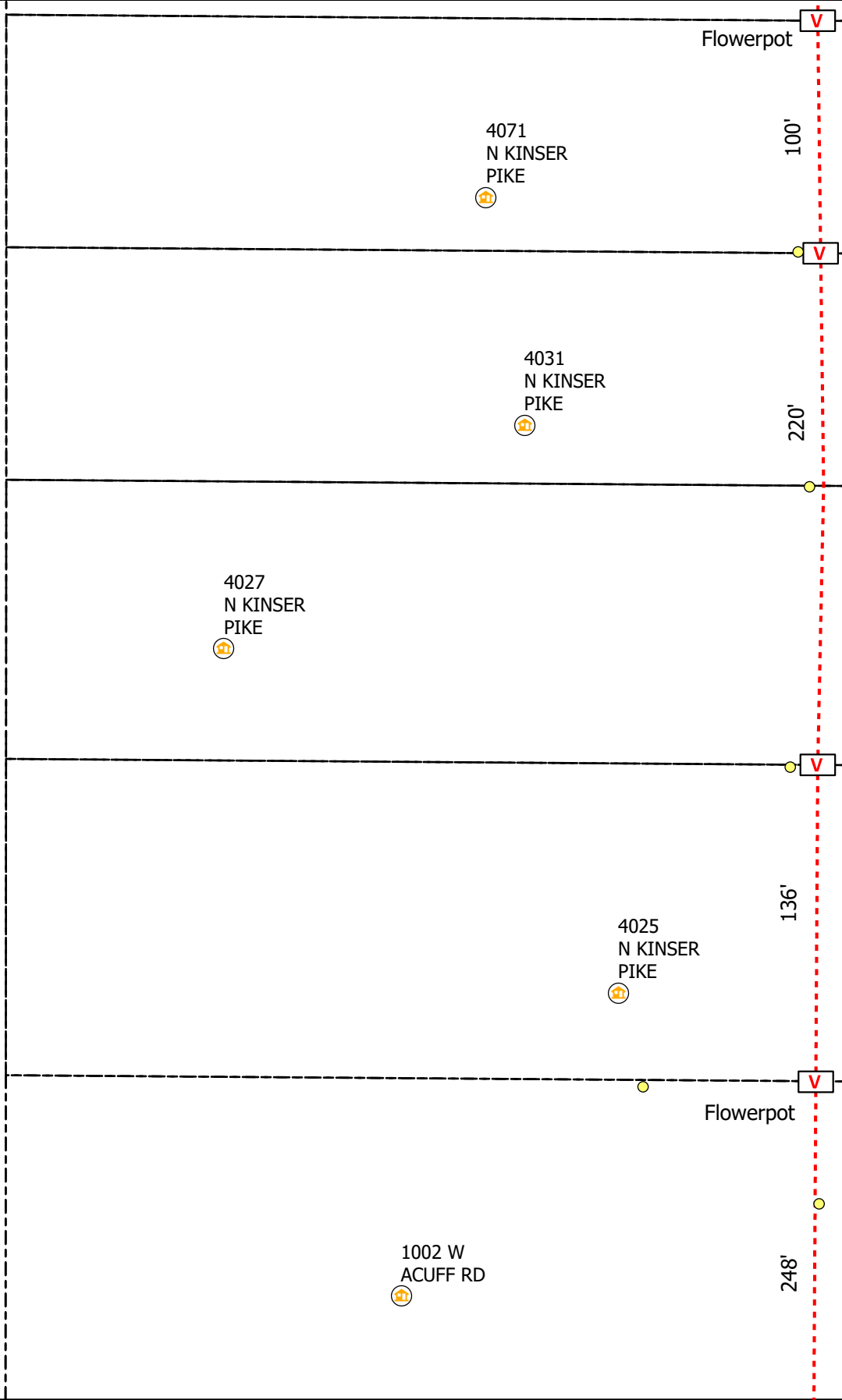

**Legend**

- Poles
- V Vaults
- Overhead Strand
- - - Conduit
- Bloomington\_Parcels
- Ⓜ Risers
- 🏠 Address
- Y Anchor
- ← Sidewalk
- Grids

All Flowerpots 12" DIA



City of Bloomington, IN Permit:  
Design View

INI	BY	DATE	DESCRIPTION



N State Road 37

W Acuff RD

234'

17x30x24











Ties into  
County Permit  
BLN01a-F04\_N  
Prow Rd

N Prow RD

3993 N  
PROW RD

1025 W  
ACUFF RD

### Legend

-  Poles
-  Vaults
-  Overhead Strand
-  Conduit
-  Bloomington\_Parcels
-  Risers
-  Address
-  Anchor
-  Sidewalk
-  Grids

All Flowerpots 12" DIA

N



City of Bloomington, IN Permit:  
Design View

INI	BY	DATE	DESCRIPTION

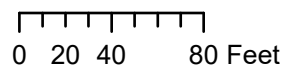

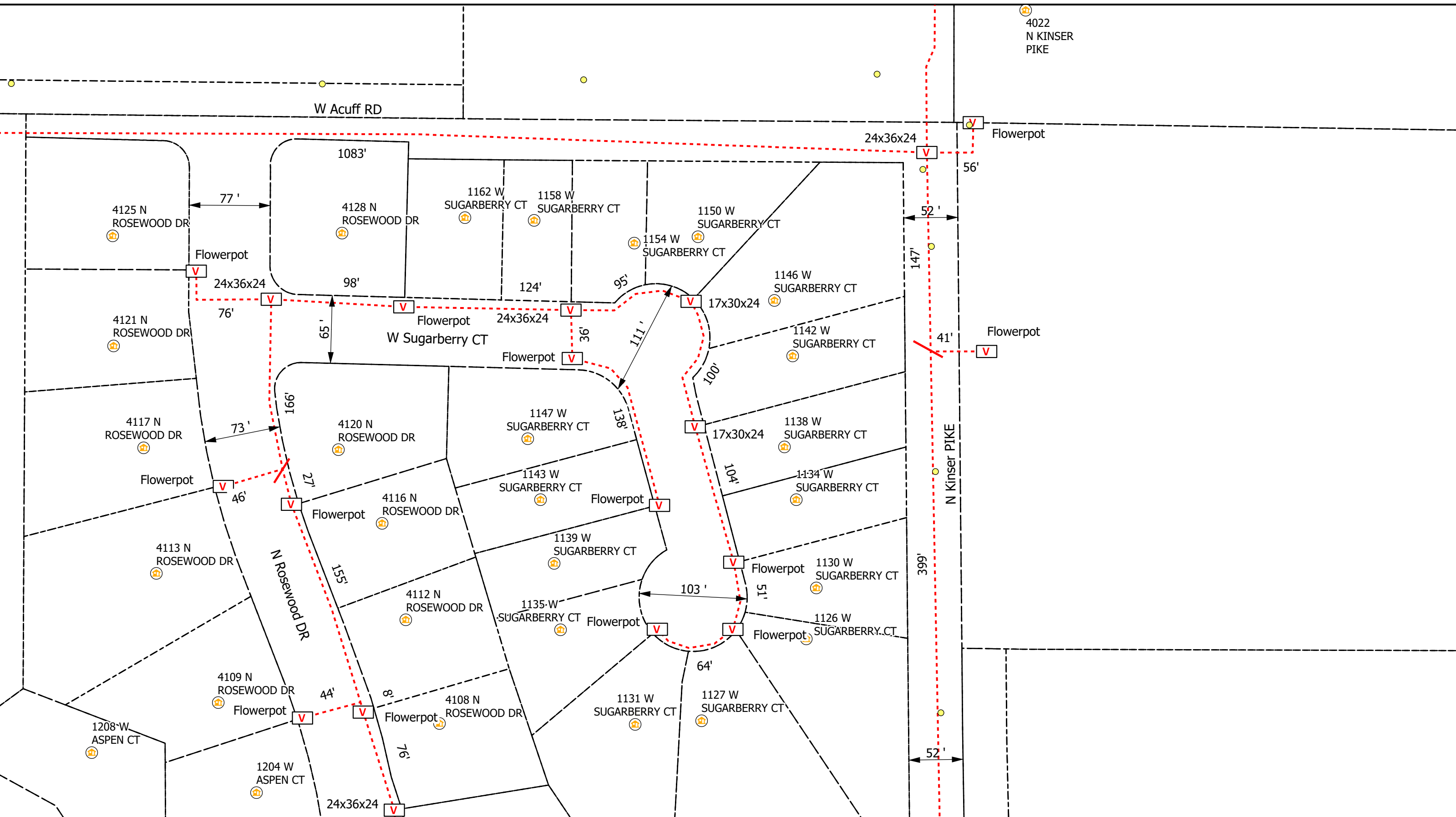

0 20 40 80 Feet

**Legend**

- Poles
- V Vaults
- Overhead Strand
- Conduit
- Bloomington\_Parcels
- R Risers
- ⊕ Address
- Y Anchor
- ← Sidewalk
- Grids

All Flowerpots 12" DIA

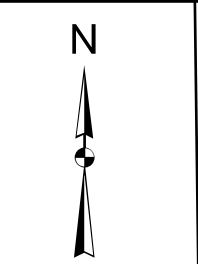

City of Bloomington, IN Permit:  
Design View

INI	BY	DATE	DESCRIPTION

Print 10 of 21

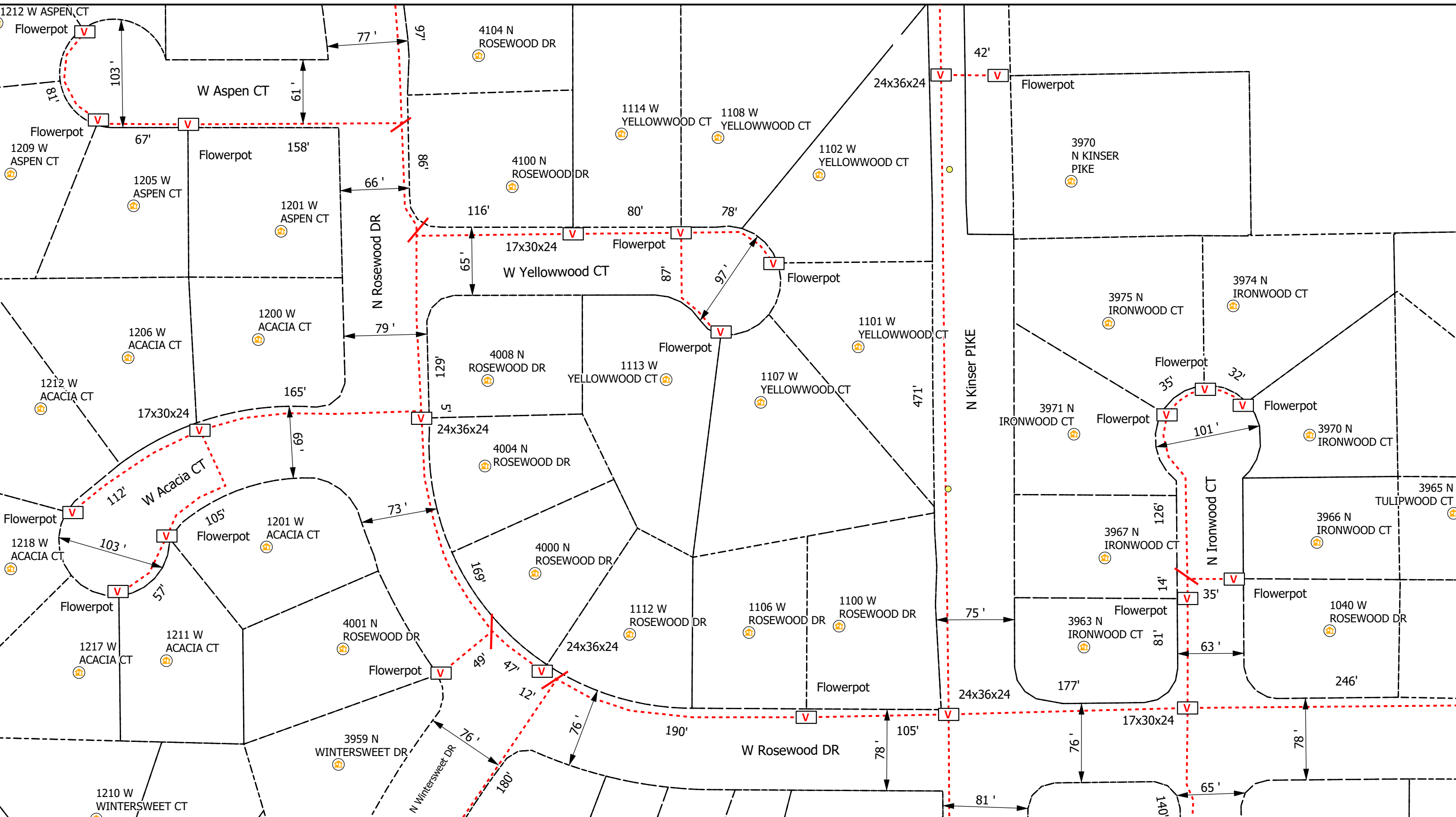

0 20 40 80 Feet

**Legend**

- Poles
- V Vaults
- Overhead Strand
- Conduit
- Bloomington\_Parcels
- R Risers
- A Address
- Y Anchor
- ← Sidewalk
- Grids

All Flowerpots 12" DIA

City of Bloomington, IN Permit:  
Design View

INI	BY	DATE	DESCRIPTION

Print 11 of 21



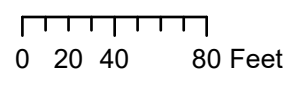
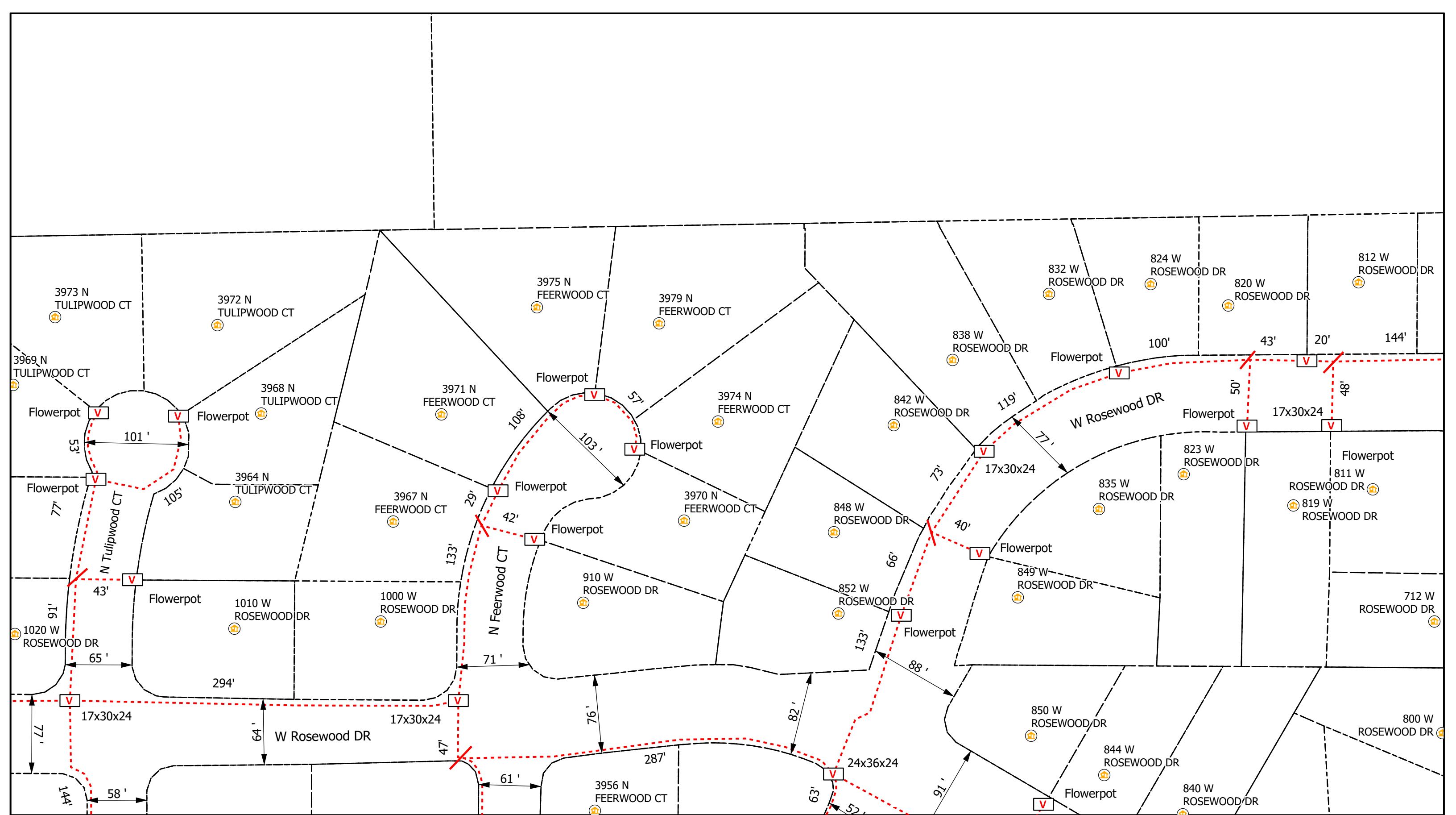

**Legend**

- Poles
- Vaults
- Overhead Strand
- Conduit
- Bloomington\_Parcels
- Risers
- Address
- Anchor
- Sidewalk
- Grids

All Flowerpots 12" DIA



City of Bloomington, IN Permit:  
Design View

INI	BY	DATE	DESCRIPTION



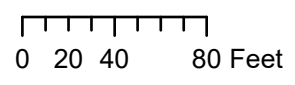
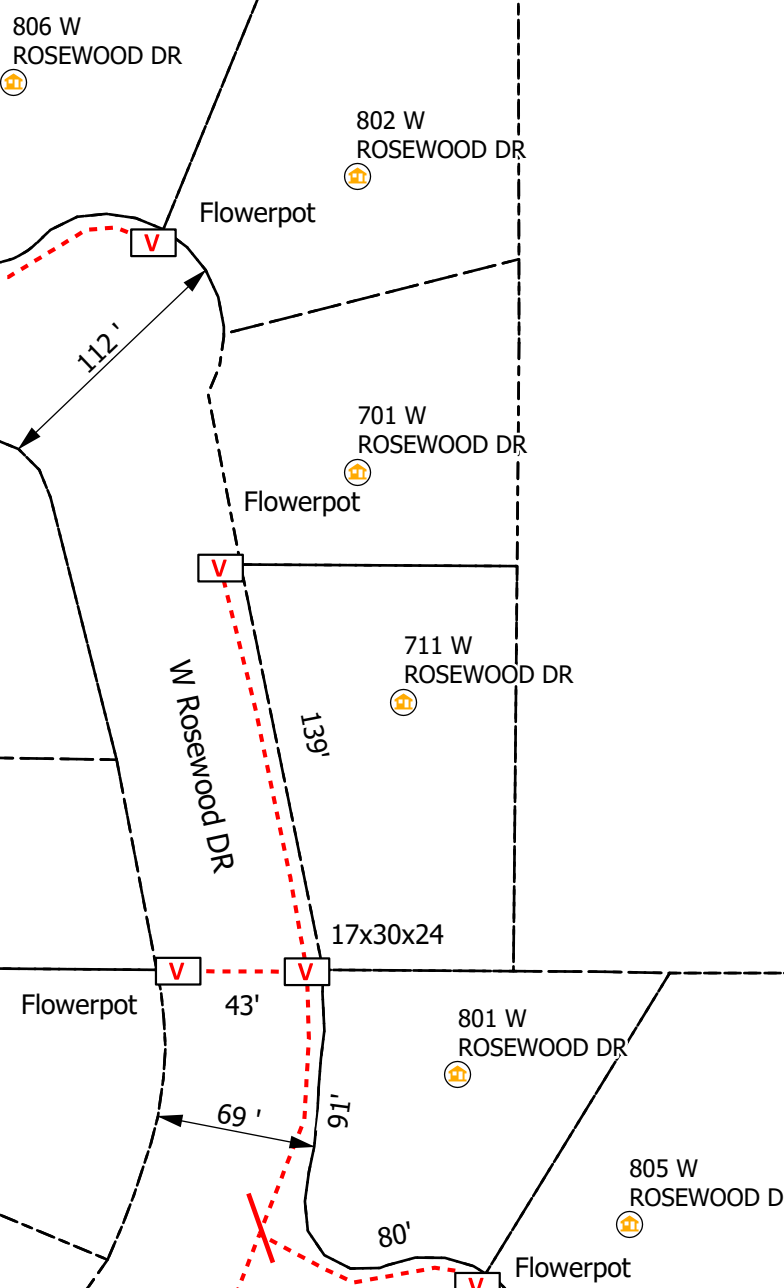

**Legend**

- Poles
- V Vaults
- Overhead Strand
- Conduit
- Bloomington\_Parcels
- R Risers
- A Address
- Anchor
- Sidewalk
- Grids

All Flowerpots 12" DIA



City of Bloomington, IN Permit:  
Design View

INI	BY	DATE	DESCRIPTION



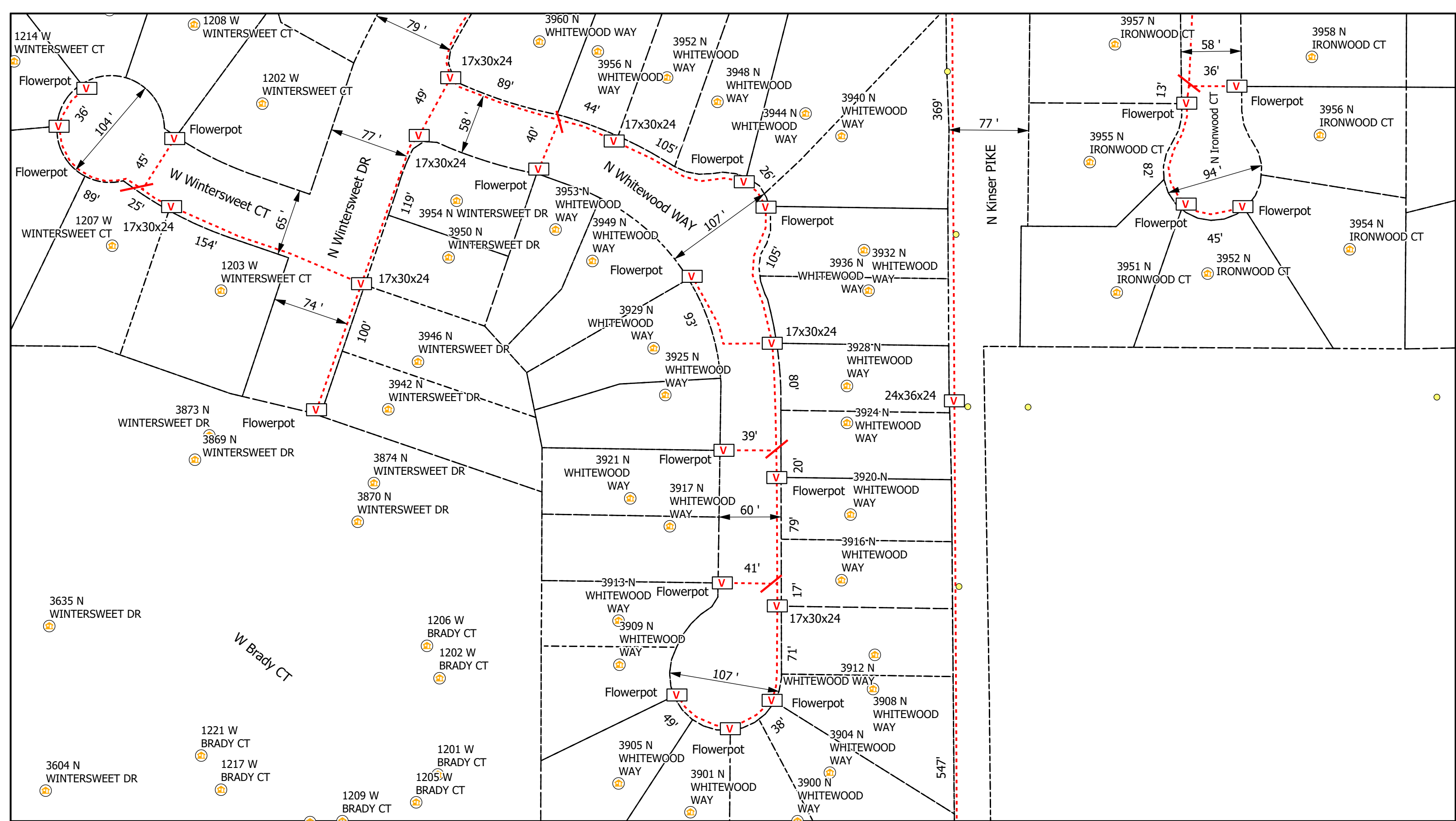

0 20 40 80 Feet

**Legend**

- Poles
- Vaults
- Overhead Strand
- Conduit
- Bloomington\_Parcels
- Risers
- Address
- Anchor
- Sidewalk
- Grids

All Flowerpots 12" DIA



City of Bloomington, IN Permit:  
Design View

INI	BY	DATE	DESCRIPTION



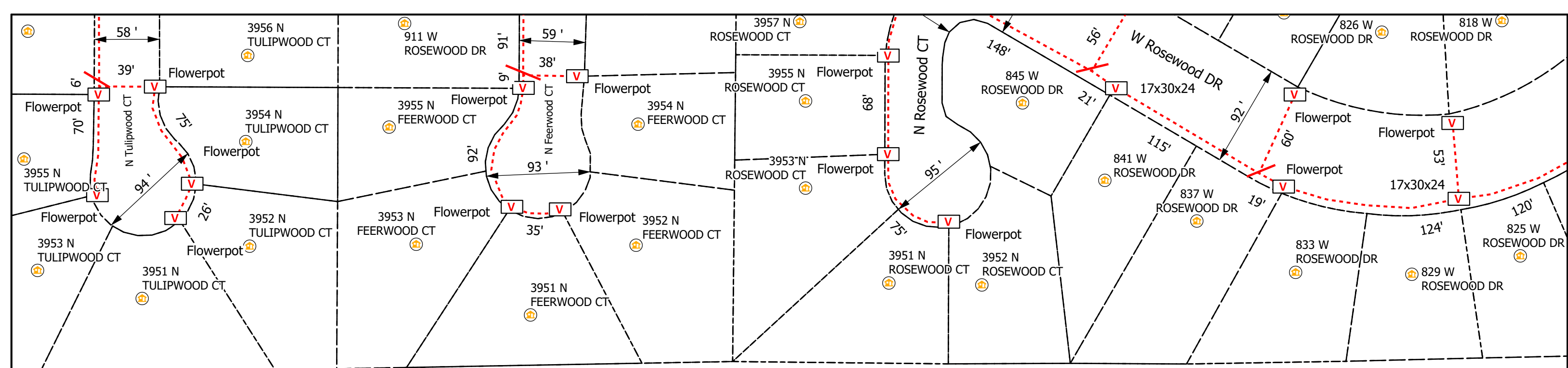

3940  
N KINSER  
PIKE

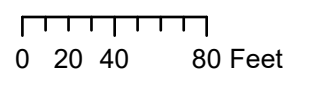

**Legend**

- Poles
- Vaults
- Overhead Strand
- Conduit
- Bloomington\_Parcels
- Risers
- Address
- Anchor
- Sidewalk
- Grids

All Flowerpots 12" DIA



City of Bloomington, IN Permit:  
Design View

INI	BY	DATE	DESCRIPTION



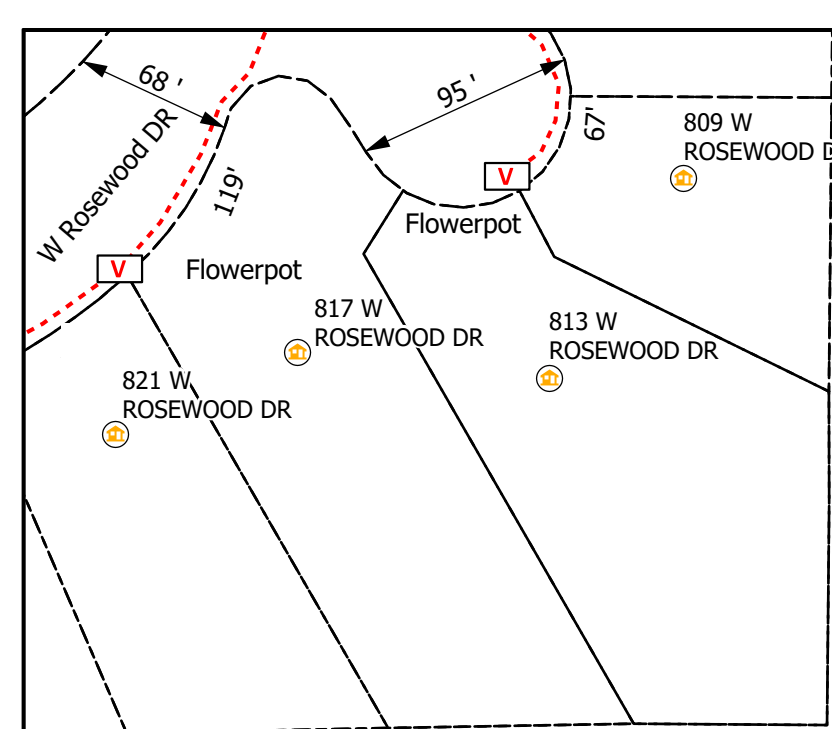

0 20 40 80 Feet

**Legend**

- Poles
- Vaults
- Overhead Strand
- Conduit
- Bloomington\_Parcels
- R Risers
- A Address
- Anchor
- Sidewalk
- Grids

All Flowerpots 12" DIA



City of Bloomington, IN Permit:  
Design View

INI	BY	DATE	DESCRIPTION





1213 W  
BRADY CT

3901 N KINSER  
PIKE TRACK  
GARAGE

3901 N KINSER  
PIKE FOOTBALL  
COMPLEX

3939  
N KINSER  
PIKE

3925  
N KINSER  
PIKE

3915  
N KINSER  
PIKE

3909  
N KINSER  
PIKE

3907  
N KINSER  
PIKE

Flowerpot

24x36x24

Flowerpot

72'

201'

98'

N Kinsler PIKE



0 20 40 80 Feet

Legend

- Poles
- Vaults
- Overhead Strand
- Conduit
- Bloomington\_Parcels
- Risers
- Address
- Anchor
- Sidewalk
- Grids

All Flowerpots 12" DIA



City of Bloomington, IN Permit:  
Design View

INI	BY	DATE	DESCRIPTION



3901 N  
KINSER PIKE  
MAINTENANCE

3905  
N KINSER  
PIKE

202'

3903  
N KINSER  
PIKE

Flowerpot

256'

N KINSER PIKE

Ties into existing  
vault and conduit  
here

3821  
N KINSER  
PIKE

3811  
N KINSER  
PIKE

3801  
N KINSER  
PIKE

3751  
N KINSER  
PIKE

3741  
N KINSER  
PIKE

3812 W  
PARKVIEW CT

3822 W  
PARKVIEW CT



0 20 40 80 Feet

**Legend**

- Poles
- Risers
- Address
- Grids
- Bloomington\_Parcels
- Vaults
- Overhead Strand
- Conduit
- Anchor
- Sidewalk

All Flowerpots 12" DIA



City of Bloomington, IN Permit:  
Design View

INI	BY	DATE	DESCRIPTION



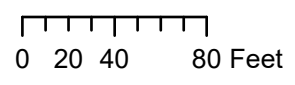
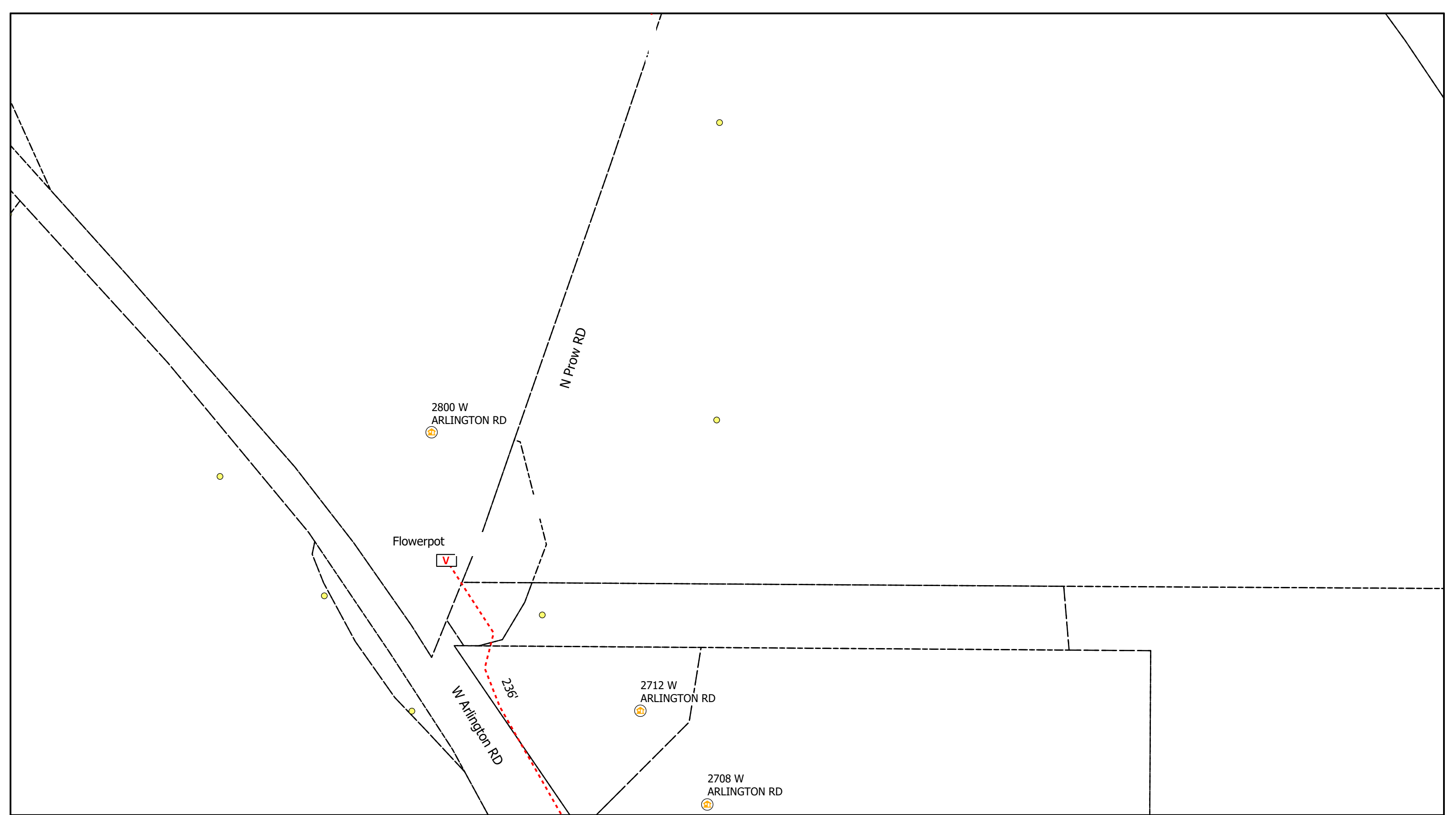

**Legend**

- Poles
- V Vaults
- Overhead Strand
- - - Conduit
- Bloomington\_Parcels
- Ⓜ Risers
- A Address
- Y Anchor
- ← Sidewalk
- Grids

All Flowerpots 12" DIA



City of Bloomington, IN Permit:  
Design View

INI	BY	DATE	DESCRIPTION



17x30x24



2704 W ARLINGTON RD



Flowerpot

89'

W Arlington RD

428'

2508 W ARLINGTON RD



17x30x24



2502 W ARLINGTON RD



148'

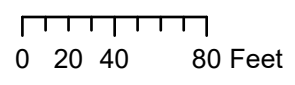

Legend

- Poles
- Bloomington\_Parcels
- Vaults
- Risers
- Overhead Strand
- Address
- Conduit
- Anchor
- Sidewalk
- Grids

All Flowerpots 12" DIA



City of Bloomington, IN Permit:  
Design View

INI	BY	DATE	DESCRIPTION



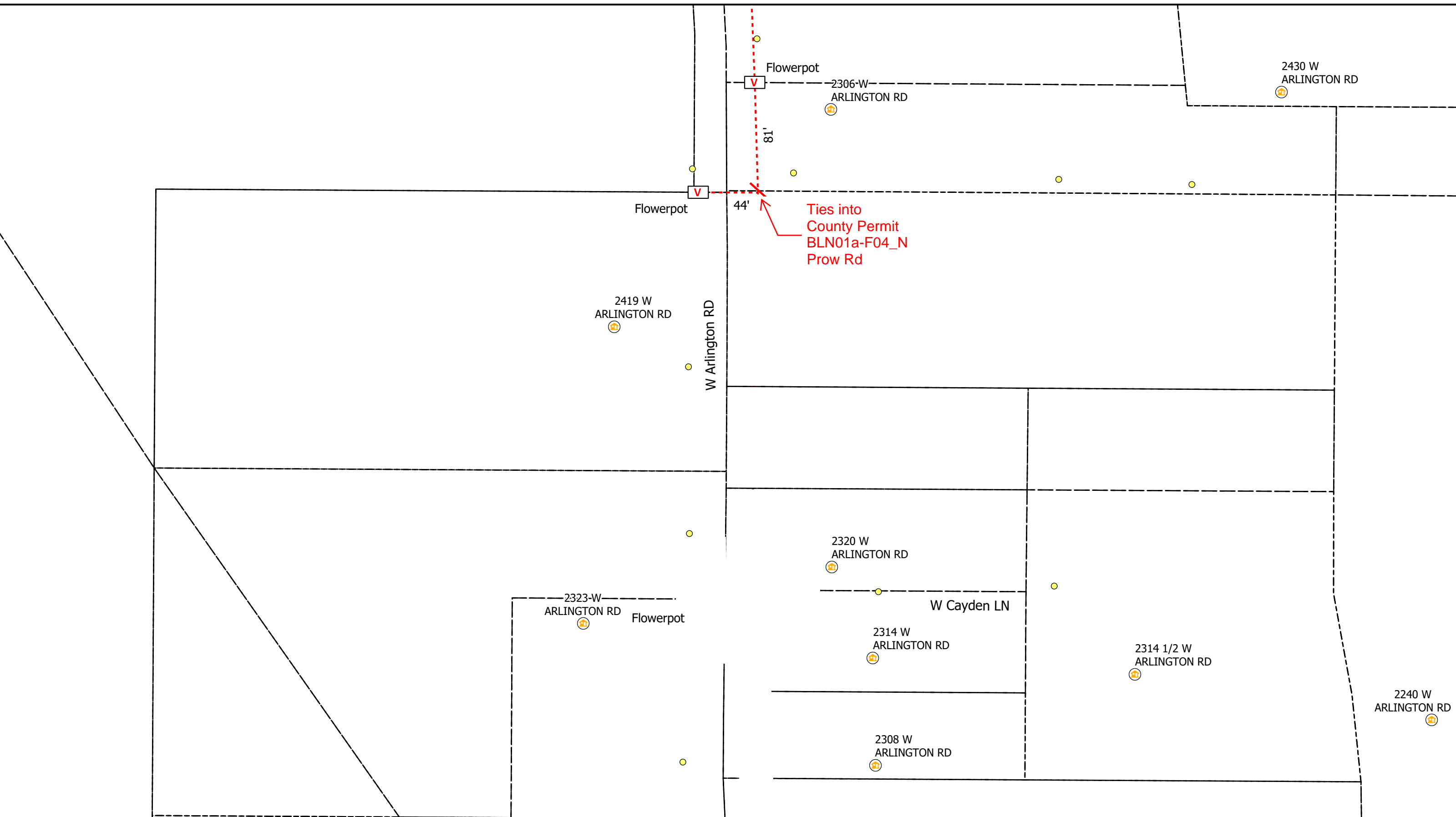

**Legend**

- Poles
- V Vaults
- Overhead Strand
- Conduit
- Bloomington\_Parcels
- R Risers
- A Address
- Y Anchor
- ← Sidewalk
- Grids

All Flowerpots 12" DIA



City of Bloomington, IN Permit:  
Design View

INI	BY	DATE	DESCRIPTION





# Carlton® PV-Mold® Nonmetallic Pole Riser System

Carlton PV-Mold is a nonmetallic pole riser system designed to protect communications power cable installed on poles.

## Features:

- Meets or exceeds requirements outlined in the National Electric Safety Code (NESC).
- Designed in accordance with NEMA TC-19 specifications.
- Ultraviolet, cold temperature and corrosive atmosphere resistant.
- Schedule 40 wall meets Schedule 80 PVC conduit impact requirements per NEMA TC-19.
- No grounding required.
- Belled end fits over each added section or conduit.
- Flame retardant.
- Requires no maintenance.
- PV-Mold acts as an insulator against electrical shock.
- Interchangeable parts and accessories to match the needs of specific requirements.



Steel U-Guard requires grounding strapping and does not have belled ends.



PV-Mold has belled ends, flanged design and does not require grounding.

## Flanged Overall Length 10 Feet, Including Bell

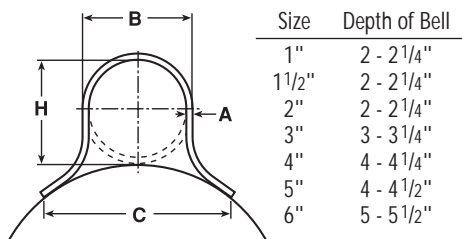

Slots are 1/2" from side to side, and allow for expansion and contraction.

Slot Dimensions: for sizes 2" through 6" are 5/16" wide, 3/4" long.

Slot Dimensions: for 1" and 1 1/2" are 3/16" wide, 3/4" long.

Slot Spacing: 18" from center, beginning 6" from end.

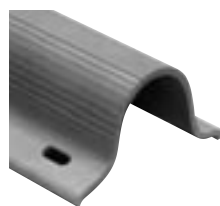

## Standard Duty

Part No.	Size	Std. Ctn. Qty.	Std. Ctn. Wt. (lbs.)	Dimensions				Actual Impact @ 0°C 20 Pound Top
				A	B	C	H	
59208N	1"	294	1059	0.100"	1 5/8"	2 3/8"	1 5/8"	40 Ft.-Lbs.
59211N	2"	136	726	0.100"	2 3/8"	4 1/2"	2 3/8"	100 Ft.-Lbs.
59211X (5' length)	2"	136	363	0.100"	2 3/8"	4 1/2"	2 3/8"	100 Ft.-Lbs.
59213N	3"	66	761	0.150"	3 1/2"	6"	3 1/2"	110 Ft.-Lbs.
59213X (5' length)	3"	66	381	0.150"	3 1/2"	6"	3 1/2"	100 Ft.-Lbs.
59215N	4"	65	910	0.150"	4 1/2"	6 1/2"	4 1/2"	110 Ft.-Lbs.
59216N	5"	30	515	0.150"	5 1/2"	7 1/2"	5 1/2"	110 Ft.-Lbs.

## Heavy Duty Schedule 40

59010N	1 1/2"	200	1142	0.145"	1 29/32"	3 1/2"	1 29/32"	100 Ft.-Lbs.
59011N	2"	136	1214	0.154"	2 3/8"	4 1/2"	2 3/8"	150 Ft.-Lbs.
59013N	3"	66	937	0.216"	3 1/2"	6"	3 9/32"	150 Ft.-Lbs.
59015N	4"	65	1621	0.237"	4 1/2"	6 1/2"	4 1/2"	260 Ft.-Lbs.
59015X (5' length)	4"	65	707	0.237"	4 1/2"	6 1/2"	4 1/2"	260 Ft.-Lbs.
59016N	5"	30	870	0.258"	5 1/2"	7 1/2"	5 1/2"	260 Ft.-Lbs.
59017N	6"	30	1160	0.280"	6 5/8"	8 3/4"	6 5/8"	260 Ft.-Lbs.

## Extra Heavy Duty Schedule 80

59411N	2"	136	1549	0.218"	2 3/8"	4 1/2"	2 3/8"	300 Ft.-Lbs.
59413N	3"	66	1495	0.030"	3 1/2"	6"	3 1/2"	525 Ft.-Lbs.

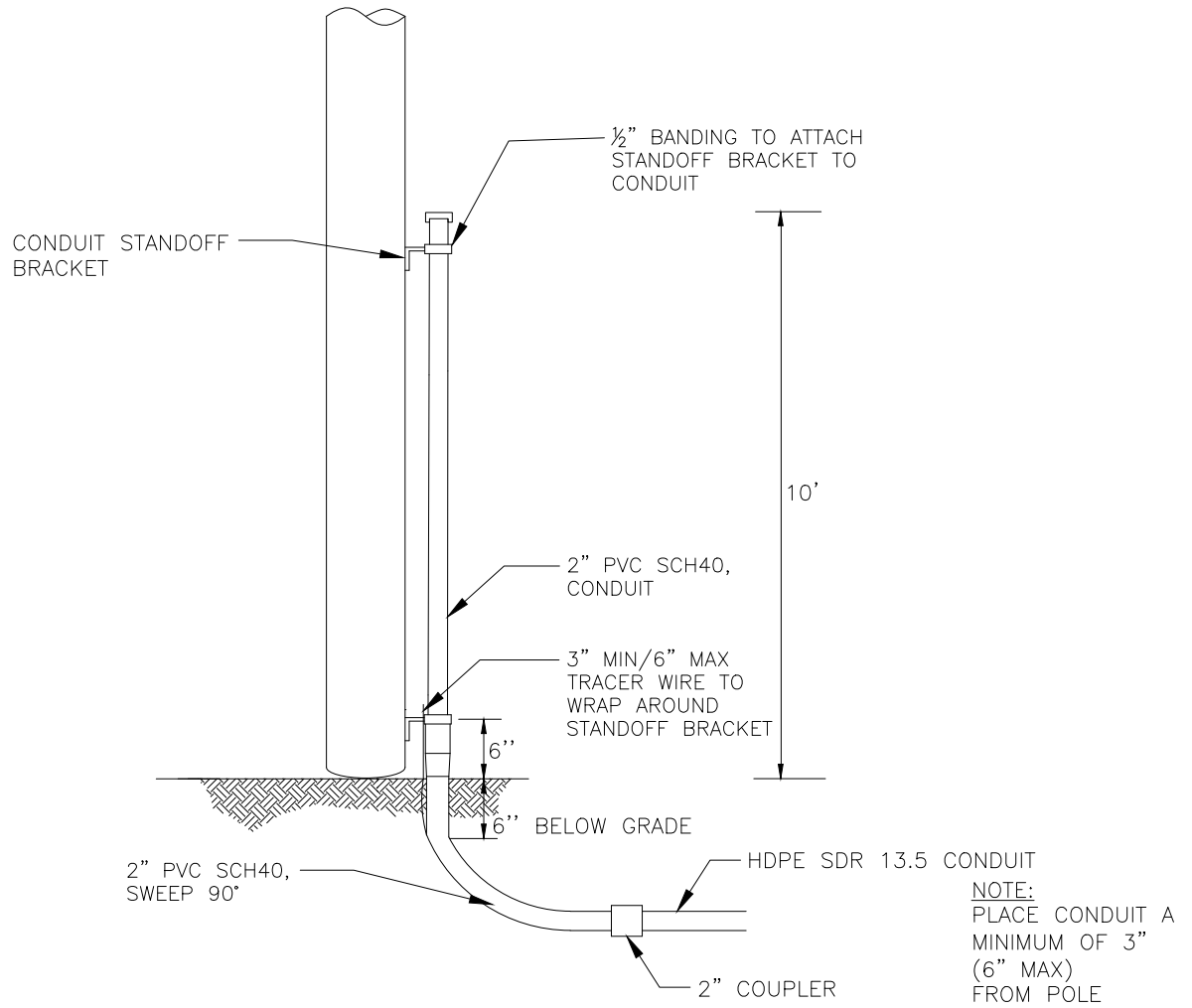

DESCRIPTION	QTY	MANUFACTURER (PREFERRED)	PART #
SCREW, LAG, 1/2" x 4-1/2"	10		
HDPE SDR 13.5 CONDUIT, VARIOUS SIZES	N/A		
2" PVC SCH40, RISER PIPE	1		
#12 TRACER WIRE	N/A		
2" PVC SCH40, SWEEP, 90 DEG	1		
CONDUIT STANDOFF BRACKET	VARIES		
CONDUIT STRAP KIT	VARIES		
2" COUPLER	1		



TYPICAL RISER  
CONDUIT  
WOOD POLE

(R2-W)

CONCEPTUAL SIDE VIEW

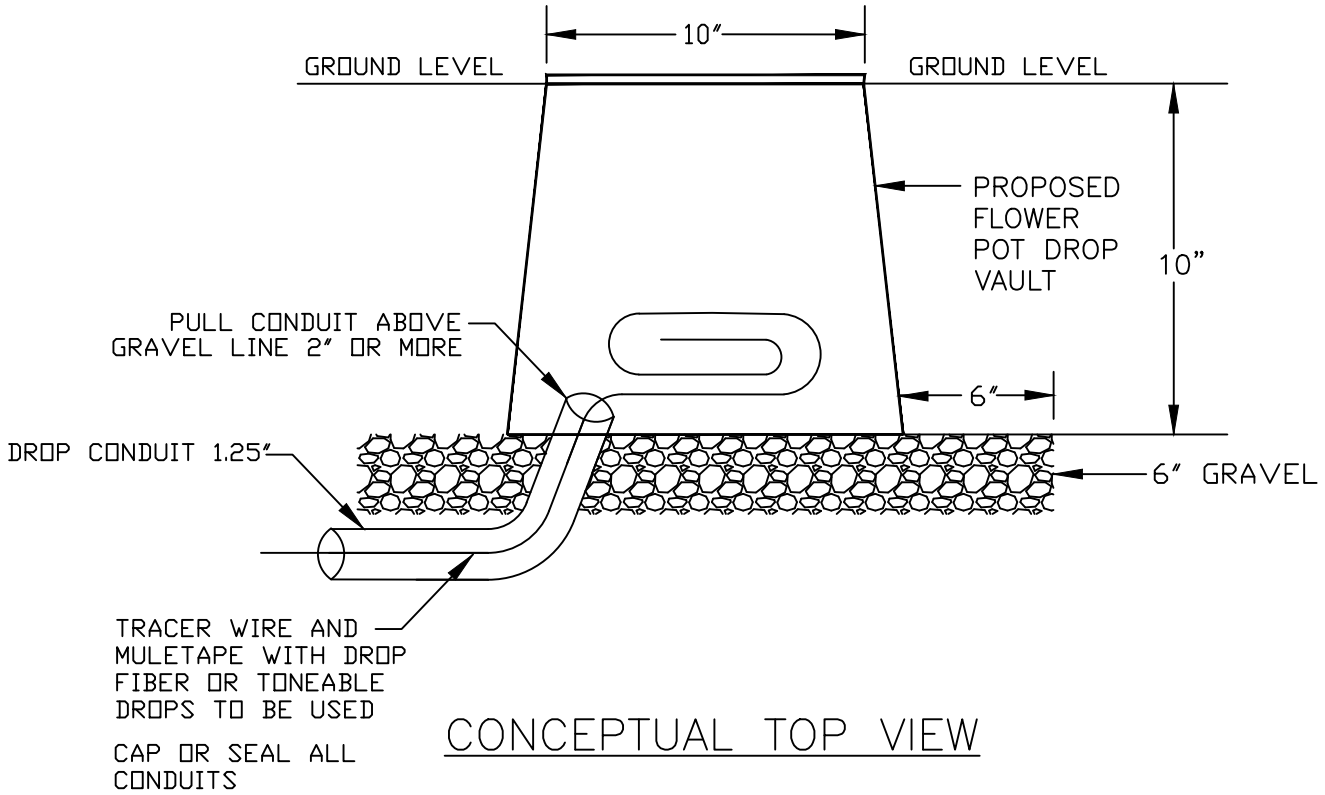

CONCEPTUAL TOP VIEW

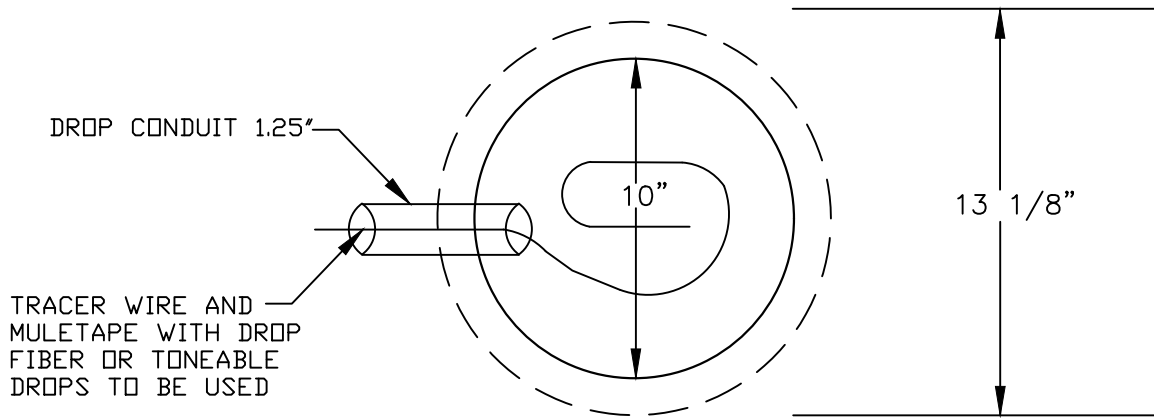

FLOWER POT

30"x48" PC UNIT, 2PC TIER 15/22  
 18", 24", and 36" HEIGHT



AMERICAN POLYMER COMPANY

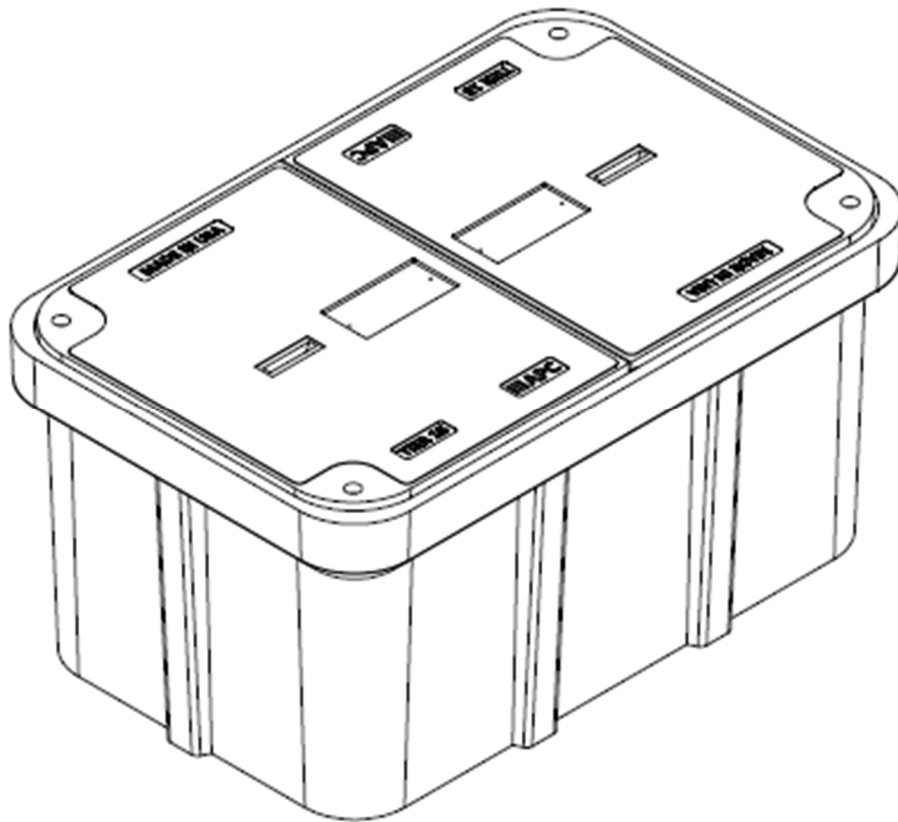

Description	Nominal Size	ANSI Tier	Part Number	Estimated Weight
PC Unit – TIER 15	30"x48"x18"	Tier 15	P304818HU15...	460 lbs.
PC Unit – TIER 22	30"x48"x18"	Tier 22	P304818HU22...	525 lbs.
PC Unit – TIER 15	30"x48"x24"	Tier 15	P304824HU15...	510 lbs.
PC Unit – TIER 22	30"x48"x24"	Tier 22	P304824HU22...	575 lbs.
PC Unit – TIER 15	30"x48"x36"	Tier 15	P304836HU15...	615 lbs.
PC Unit – TIER 22	30"x48"x36"	Tier 22	P304836HU22...	680 lbs.



# 30"x48" PC UNIT, 2PC TIER 15/22

18", 24", and 36" HEIGHT



AMERICAN POLYMER COMPANY

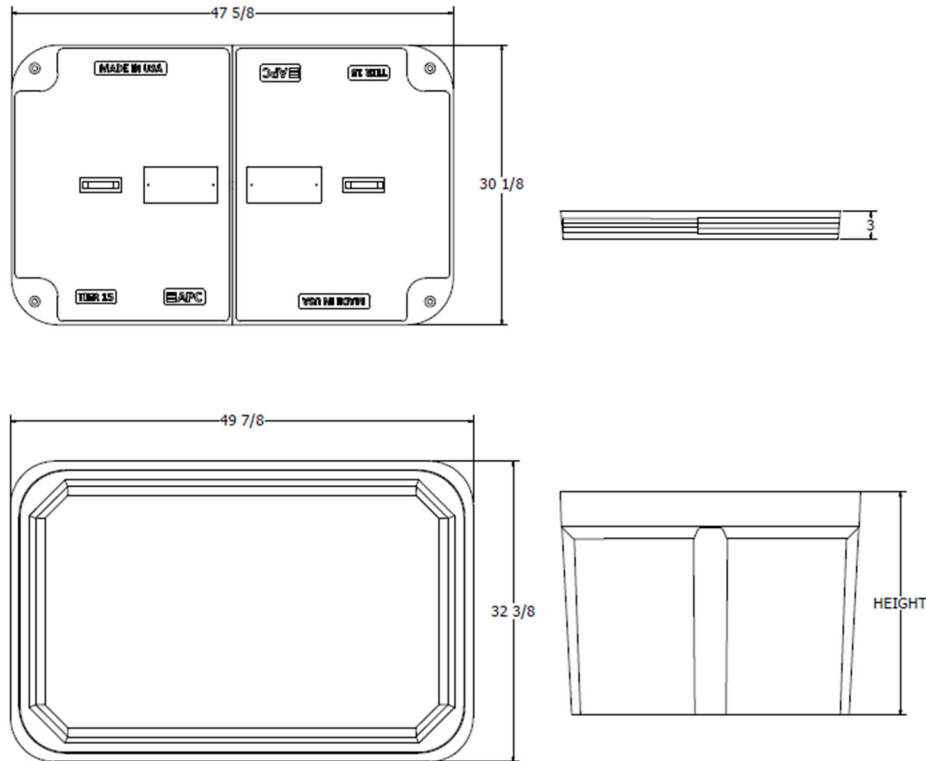

Components	Nominal Size	ANSI Tier	Part Number	Estimated Weight
Replacement Box	30"x48"x18"	Tier 22	P304818B22	185 lbs.
Replacement Box	30"x48"x24"	Tier 22	P304824B22	235 lbs.
Replacement Box	30"x48"x36"	Tier 22	P304836B22	340 lbs.
Replacement Lids - T15	30"x48" (half)	Tier 15	Various	150 lbs.
Replacement Lids - T22	30"x48" (half)	Tier 22	Various	170 lbs.

### Bolt options



Machine Thread



Auger Thread





24"x36" PC UNIT, TIER 15/22  
 18", 24", 30", and 36" HEIGHT



AMERICAN POLYMER COMPANY

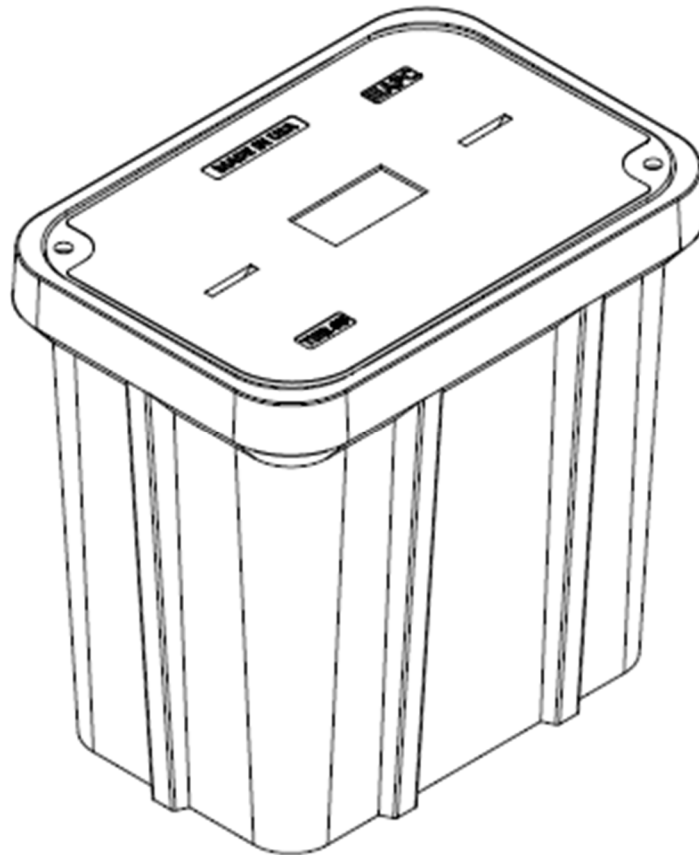

Description	Nominal Size	ANSI Tier	Part Number	Estimated Weight
PC Unit – TIER 15	24x36"x18"	Tier 15	P243618U15...	335 lbs.
PC Unit – TIER 22	24x36"x18"	Tier 22	P243618U22...	355 lbs.
PC Unit – TIER 15	24x36"x24"	Tier 15	P243624U15...	365 lbs.
PC Unit – TIER 22	24x36"x24"	Tier 22	P243624U22...	385 lbs.
PC Unit – TIER 15	24x36"x30"	Tier 15	P243630U15...	395 lbs.
PC Unit – TIER 22	24x36"x30"	Tier 22	P243630U22...	415 lbs.
PC Unit – TIER 15	24x36"x36"	Tier 15	P243636U15...	425 lbs.
PC Unit – TIER 22	24x36"x36"	Tier 22	P243636U22...	445 lbs.



# 24"x36" PC UNIT, TIER 15/22

18", 24", 30", and 36" HEIGHT



AMERICAN POLYMER COMPANY

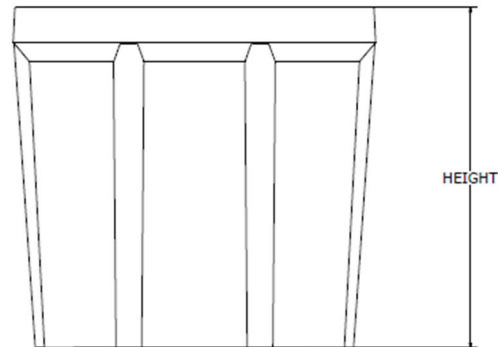
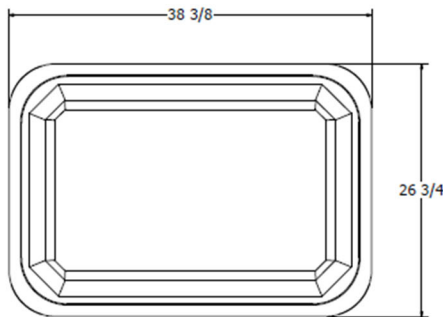
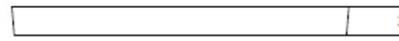
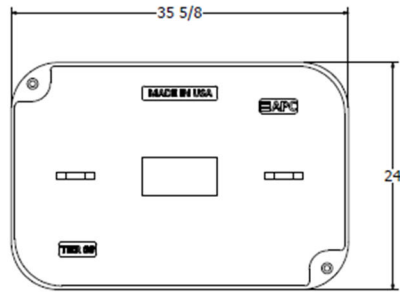

Components	Nominal Size	ANSI Tier	Part Number	Estimated Weight
Replacement Box	24"x36"x18"	Tier 22	P243618B22	165 lbs.
Replacement Box	24"x36"x24"	Tier 22	P243624B22	195 lbs.
Replacement Box	24"x36"x30"	Tier 22	P243630B22	225 lbs.
Replacement Box	24"x36"x36"	Tier 22	P243636B22	255 lbs.
Replacement Lids - T15	24"x36"	Tier 15	Various	170 lbs.
Replacement Lids - T22	24"x36"	Tier 22	Various	190 lbs.

### Bolt options

Hex Head



Machine Thread



Penta Head



Auger Thread



17"x30" PC UNIT, TIER 15/22

12", 18", 24", and 30" HEIGHT



AMERICAN POLYMER COMPANY

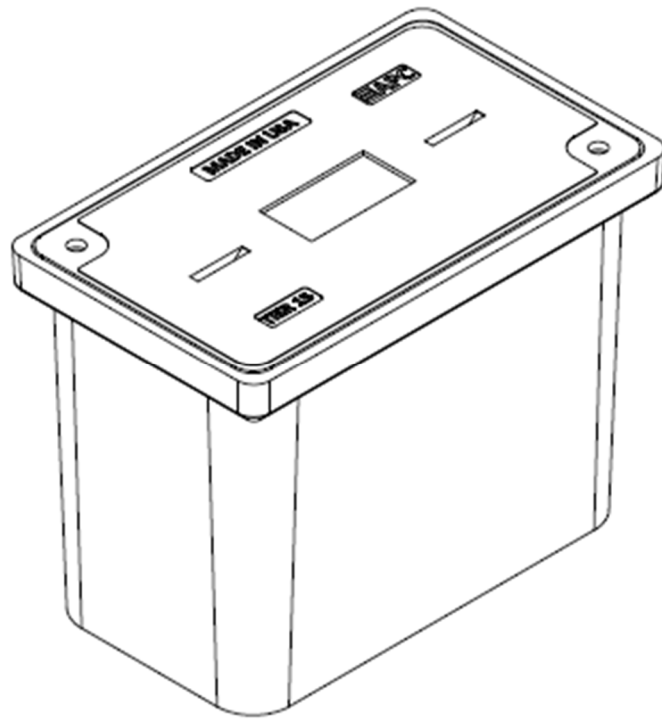

Description	Nominal Size	ANSI Tier	Part Number	Estimated Weight
PC Unit – TIER 15	17"x30"x12"	Tier 15	P173012U15...	138 lbs.
PC Unit – TIER 22	17"x30"x12"	Tier 22	P173012U22...	147 lbs.
PC Unit – TIER 15	17"x30"x18"	Tier 15	P173018U15...	172 lbs.
PC Unit – TIER 22	17"x30"x18"	Tier 22	P173018U22...	181 lbs.
PC Unit – TIER 15	17"x30"x24"	Tier 15	P173024U15...	192 lbs.
PC Unit – TIER 22	17"x30"x24"	Tier 22	P173024U22...	201 lbs.
PC Unit – TIER 15	17"x30"x30"	Tier 15	P173030U15...	217 lbs.
PC Unit – TIER 22	17"x30"x30"	Tier 22	P173030U22...	226 lbs.



# 17"x30" PC UNIT, TIER 15/22

12", 18", 24", and 30" HEIGHT



AMERICAN POLYMER COMPANY

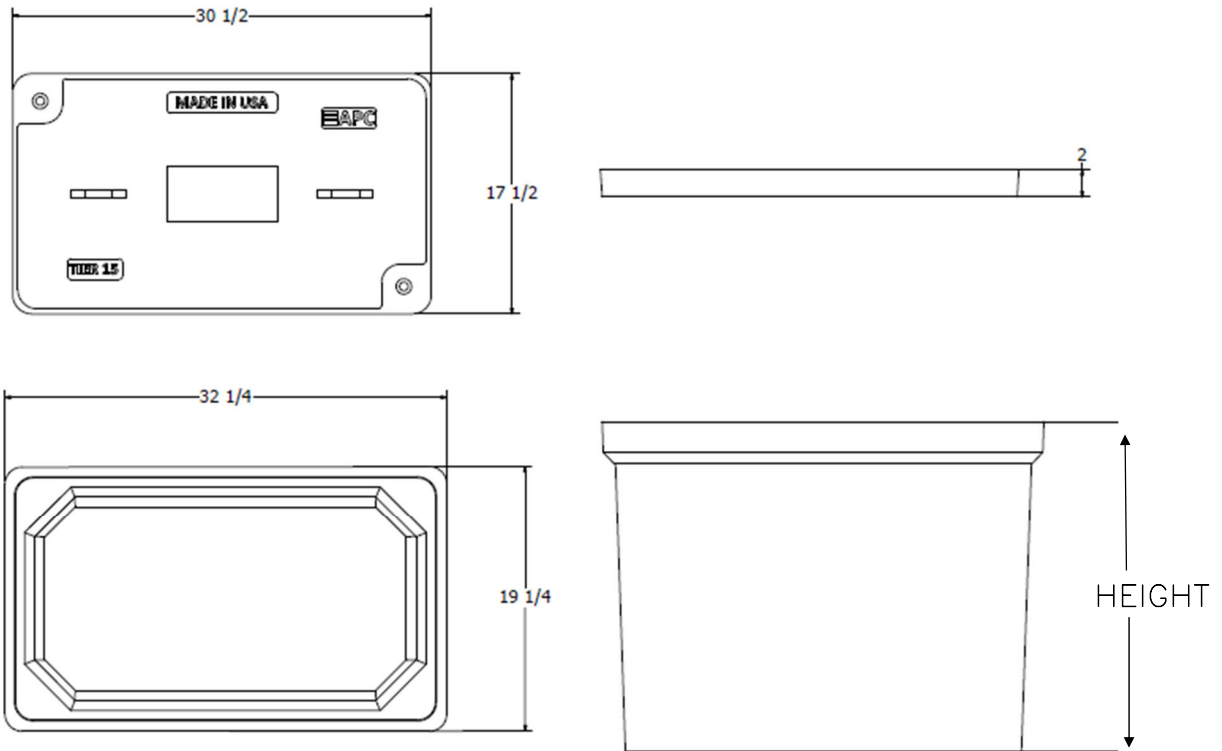

Components	Nominal Size	ANSI Tier	Part Number	Estimated Weight
Replacement Box	17"x30"x12"	Tier 22	P173012B22	66 lbs.
Replacement Box	17"x30"x18"	Tier 22	P173018B22	100 lbs.
Replacement Box	17"x30"x24"	Tier 22	P173024B22	120 lbs.
Replacement Box	17"x30"x30"	Tier 22	P173030B22	145 lbs.
Replacement Lids – T15	17"x30"	Tier 15	Various	72 lbs.
Replacement Lids – T22	17"x30"	Tier 22	Various	81 lbs.

### Bolt options



Machine Thread



Auger Thread



33"x60" PC UNIT, 2PC TIER 15/22  
36" HEIGHT



AMERICAN POLYMER COMPANY

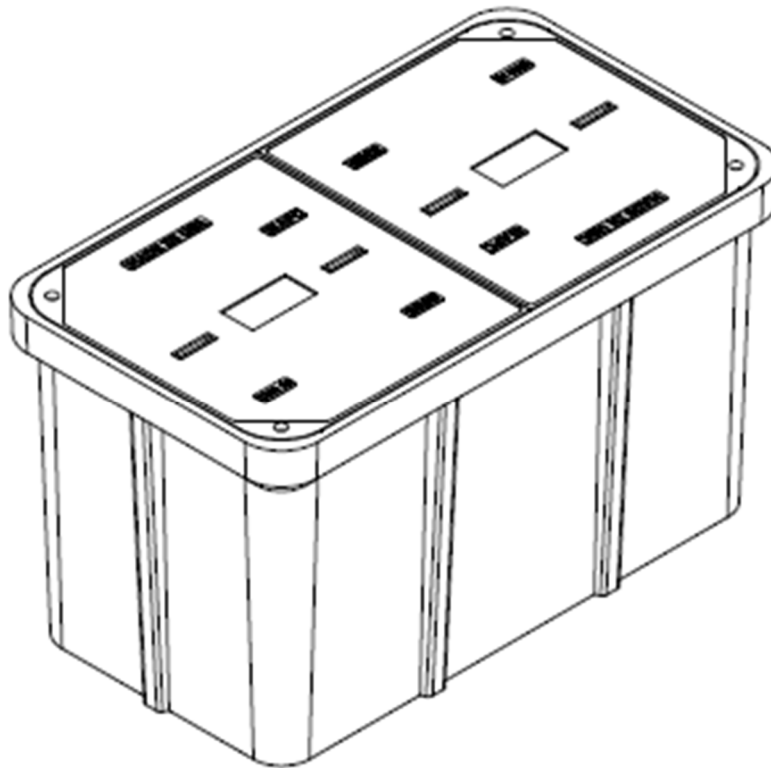

Description	Nominal Size	ANSI Tier	Part Number	Estimated Weight
PC Unit - TIER 15	33"x60"x36"	Tier 15	P336036U15...	930 lbs.
PC Unit - TIER 22	33"x60"x36"	Tier 22	P336036U22...	1030 lbs.





# 33"x60" PC UNIT, 2PC TIER 15/22

## 36" HEIGHT



AMERICAN POLYMER COMPANY

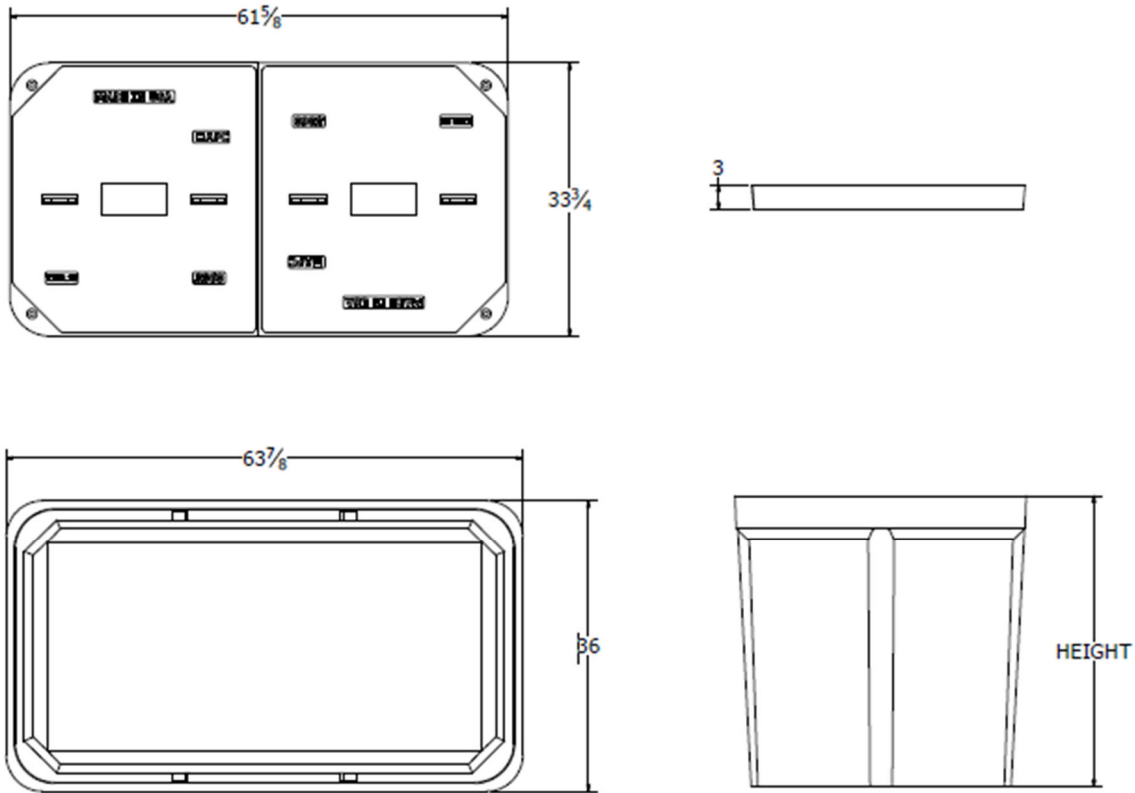

Components	Nominal Size	ANSI Tier	Part Number	Estimated Weight
Replacement Box	33"x60"x36"	Tier 22	P336036B22	530 lbs.
Replacement Lids - T15	33"x60" (half)	Tier 15	Various	200 lbs.
Replacement Lids - T22	33"x60" (half)	Tier 22	Various	250 lbs.

### Bolt options

Hex Head



Machine Thread



Penta Head



Auger Thread





Speed (MPH) Prior To Road Work	SIGN SPACING, FT.		Must be Approved by an Engineer				
	Non-Divided Highways	Divided Highways	BUFFER SPACE, FT.	TAPER LENGTH, FT.		CHANNELIZING SPACING, FT.	
				Length	Shoulder (10 ft. Width)	Lane (12 ft. Width)	Through Taper
0-35	200	200	250	70	245	35	50
40-45	350	500	360	150	540	40	80
50-55	500	1000	495	185	660	50	100
60-70	SA-1000, SB-1500, SC-2640		730	235	840	60	120
Urban Low Speed - 100 FT							

APPROVED/ACCEPTED BY:  
ENGINEER, OWNER, or PRIME CONTRACTOR  
 Check for Notice to Proceed.  
BLN01a-F04\_N Prow Rd -TCP1

Signature: \_\_\_\_\_

Company: \_\_\_\_\_

**Date:** 2/13/2023 **Project:** BLN01a-F04 N Prow Rd -TCP1 :  
: **Traffic Control Suggestion For:** AEG :  
**By:** Road Runner Safety Services, Inc. : Nathan

**Comments:**  
Drawing not to scale. Traffic control plan must be approved by an engineer. This is a suggestion only. Road Runners Safety Services, Inc. has no liability for this suggested traffic control plan. Actual placement and spacing of all traffic control devices will depend on field conditions and must conform to MUTCD standards.



- Legend**
- ADA Barricade
  - Channelizer
  - Conduit
  - Flagger (Person)
  - Sign
  - Vault
  - Work Area

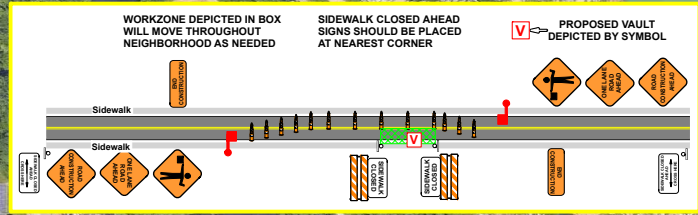

Sheet 2



Speed (MPH) Prior To Road Work	SIGN SPACING, FT.		Must be Approved by an Engineer				
	Non-Divided Highways	Divided Highways	BUFFER SPACE, FT.	TAPER LENGTH, FT.	CHANNELIZING SPACING, FT.		
	Length	Shoulder (10 ft. Width)	Lane (12 ft. Width)	Through Taper	Through Buffer/Work Area	Through Buffer/Work Area	
0-35	200	200	250	70	245	35	50
40-45	350	500	360	150	540	40	80
50-55	500	1000	495	185	660	50	100
60-70	SA-1000, SB-1500, SC-2640 Urban Low Speed - 100 FT		730	235	840	60	120

APPROVED/ACCEPTED BY:  
ENGINEER, OWNER, or PRIME CONTRACTOR  
 Check for Notice to Proceed.  
BLN01a-F04\_N\_Prow Rd -TCP2

Signature: \_\_\_\_\_

Company: \_\_\_\_\_

**Road Runner**  
Safety Services, Inc.

Date: 2/13/2023 Project: BLN01a-F04 N Prow Rd -TCP2 :  
: Traffic Control Suggestion For: AEG :  
By: Road Runner Safety Services, Inc. : Nathan

Comments:  
Drawing not to scale. Traffic control plan must be approved by an engineer. This is a suggestion only. Road Runners Safety Services, Inc. has no liability for this suggested traffic control plan. Actual placement and spacing of all traffic control devices will depend on field conditions and must conform to MUTCD standards.

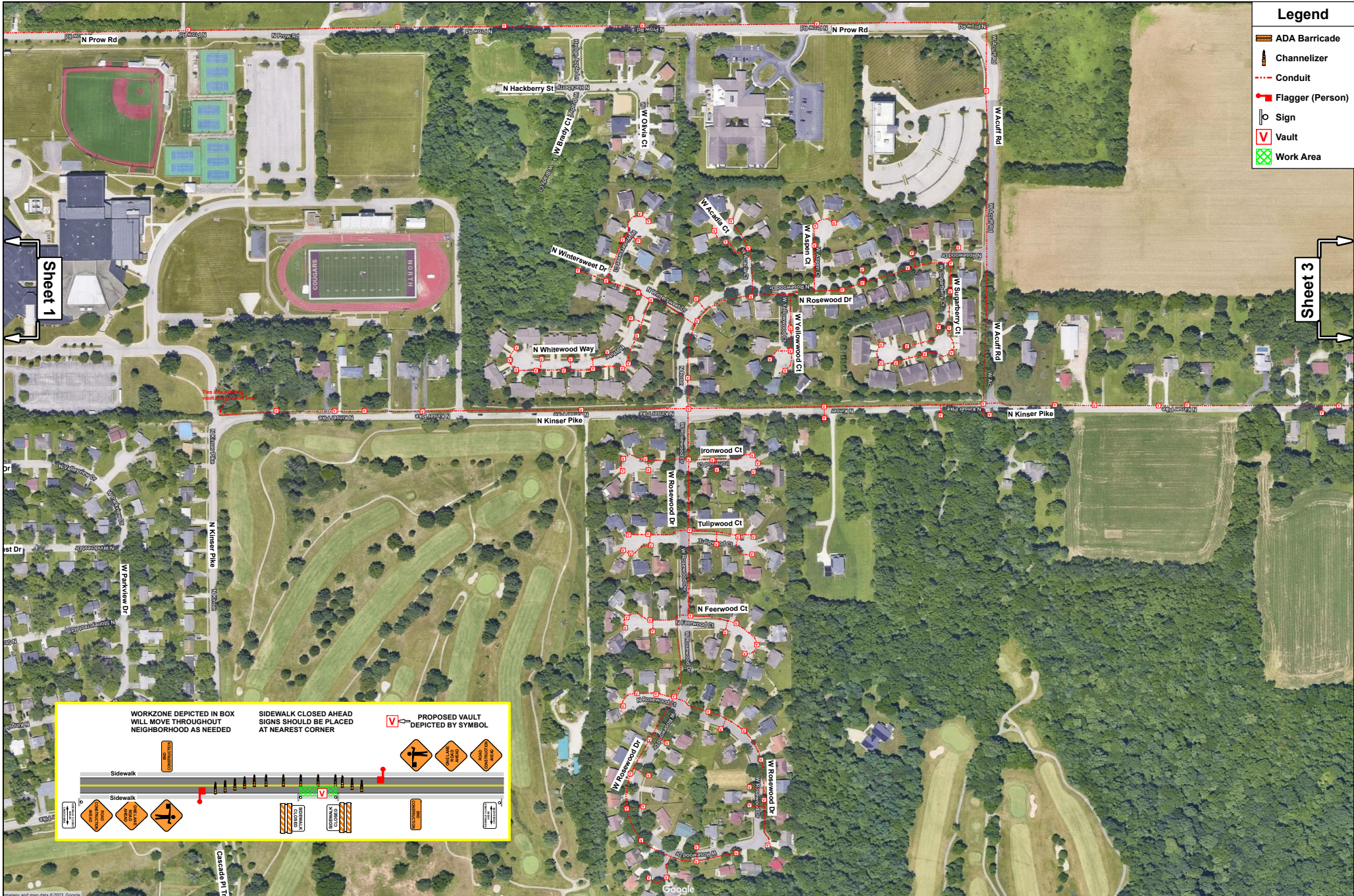

- Legend**
- ADA Barricade
  - Channelizer
  - Conduit
  - Flagger (Person)
  - Sign
  - Vault
  - Work Area

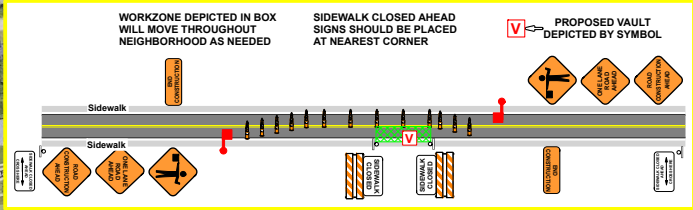



Spacing Charts Based on MUTCD		Must be Approved by an Engineer					
Speed (MPH) Prior To Road Work	SIGN SPACING, FT.		BUFFER SPACE, FT.	TAPER LENGTH, FT.		CHANNELIZING SPACING, FT.	
	Non-Divided Highways	Divided Highways	Length	Shoulder (10 ft. Width)	Lane (12 ft. Width)	Through Taper	Through Buffer/Work Area
0-35	200	200	250	70	245	35	50
40-45	350	500	360	150	540	40	80
50-55	500	1000	495	185	660	50	100
60-70	SA-1000, SB-1500, SC-2640		730	235	840	60	120
Urban Low Speed - 100 FT							

APPROVED/ACCEPTED BY:  
ENGINEER, OWNER, or PRIME CONTRACTOR  
 Check for Notice to Proceed.  
**BLN01a-F04\_N Prow Rd -TCP3**

Signature: \_\_\_\_\_

Company: \_\_\_\_\_



Date: 2/13/2023 Project: BLN01a-F04\_N Prow Rd -TCP3 :  
Traffic Control Suggestion For: AEG :  
By: Road Runner Safety Services, Inc. : Nathan

**Comments:**  
Drawing not to scale. Traffic control plan must be approved by an engineer. This is a suggestion only. Road Runners Safety Services, Inc. has no liability for this suggested traffic control plan. Actual placement and spacing of all traffic control devices will depend on field conditions and must conform to MUTCD standards.







# CITY OF BLOOMINGTON RIGHT-OF-WAY USE PERMIT APPLICATION

401 N Morton Street, Suite 130  
P.O. Box 100  
Bloomington, IN 47402

Phone: (812) 349-3913  
Fax: (812) 349-3520  
Email:  
engineering@bloomington.in.gov

ROW EXCAVATION  ROW USE

ADDRESS OF ROW ACTIVITY: Acuff Rd

<b>A. APPLICANT/AGENT INFORMATION:</b>		<b>D. TRAFFIC CONTROL DEVICES*:</b>	
APPLICANT NAME: <u>Bret Simons</u>		<input checked="" type="checkbox"/> CONES <input type="checkbox"/> ARROWBOARD	
E-MAIL: <u>bret.simons@aeg.cc</u>		<input type="checkbox"/> LIGHTED BARRELS <input checked="" type="checkbox"/> TYPE 3 BARRICADES	
COMPANY: <u>Atlantic Engineering Group</u>		<input checked="" type="checkbox"/> FLAGGERS <input type="checkbox"/> BPD OFFICER	
ADDRESS: <u>P.O. Box 349</u>		*PROVIDING MUTCD COMPLIANT TEMPORARY TRAFFIC CONTROL DEVICES AND MAINTENANCE OF TRAFFIC (MOT) PLAN IS YOUR RESPONSIBILITY AND REQUIRED. See page 3 for additional MOT resources; the graph paper can be used for your MOT site plan if needed or you can submit a separate sheet	
CITY, STATE, ZIP: <u>Buford, GA 30515</u>			
24-HR EMERGENCY CONTACT NAME: <u>(706)654-2298</u>		<b>E. METERED PARKING SPACES NEEDED: <input type="checkbox"/> Y <input type="checkbox"/> N</b>	
24-HR CONTACT PHONE #: _____		IT IS THE RESPONSIBILITY OF THE APPLICANT TO RESERVE PARKING METER(S) APPLICATION LOCATED: <a href="https://bloomington.in.gov/transportation/parking/moving">https://bloomington.in.gov/transportation/parking/moving</a> OR CONTACT PARKING SERVICES WITH QUESTIONS AT (812)349-3436	
INSURANCE #*: <u>TB5-691-473497-082</u> COMPANY: <u>ACORD</u>		<b>F. IS THIS A <input type="checkbox"/> CBU* <input type="checkbox"/> COUNTY* <input type="checkbox"/> IU* <input type="checkbox"/> NP* PROJECT?</b>	
BOND #*: <u>1160465</u> COMPANY: <u>LEXON</u>		PROJECT NAME: <u>BLN01a-F04 Acuff Rd</u>	
*INSURANCE & BOND MUST BE ON FILE WITH THE CITY BEFORE PERMIT WILL BE ISSUED		PROJECT #: <u>BLN01a-F04 Acuff Rd</u>	
<b>**SUBCONTRACTOR INFORMATION**</b>		PROJECT MGR.: <u>Lex Mullins</u>	
(LIST ALL COMPANIES WORKING UNDER PRIMARY CONTRACTOR PERMIT)		PROJECT MGR. #: <u>215-847-8819</u>	
COMPANY NAME: _____		*CBU = CITY OF BLOOMINGTON UTILITIES *COUNTY = MONROE COUNTY	
<b>B. WORK DESCRIPTION:</b>		*IU = INDIANA UNIVERSITY *NP = NOT-FOR-PROFIT AGENCY	
<input type="checkbox"/> POD/DUMPSTER <input type="checkbox"/> CRANE <input type="checkbox"/> SCAFFOLDING <input checked="" type="checkbox"/> CONSTRUCTION USE*		<b>G. EXCAVATIONS:</b>	
(EXPLAIN): <u>Excavation</u>		SQ FT OF PAVEMENT* EXCAVATIONS: <u>N/A</u>	
*EXCAVATION, LONG TERM USE FOR STORAGE OF MATERIAL/EQUIPMENT/WALKAROUND		*PAVEMENT INCLUDES: IN OR UNDER CONCRETE, OR ASPHALT INCLUDING CURBS	
<b>C. RIGHT OF WAY TO BE USED/CLOSED:</b>		SQ FT OF NON-PAVEMENT* EXCAVATIONS: <u>372.58 Sq Ft</u>	
STREET NAME 1: <u>Acuff Rd</u>		*DIRT, GRASS, GRAVEL, LANDSCAPE AREA OR OTHER UNPAVED SURFACE	
1ST INTERSECTING STREET NAME: _____		LINEAL FT OF BORE*: <u>19,325 Lineal Ft</u>	
2ND INTERSECTING STREET NAME: _____		*BORE PITS SHALL BE CALCULATED AS SQ FT EXCAVATIONS	
<input type="checkbox"/> ROAD CLOSURE <input checked="" type="checkbox"/> LANE CLOSURE 1 <input checked="" type="checkbox"/> 2 <input type="checkbox"/> 3 <input type="checkbox"/>		# OF POLE INSTALLATIONS/REMOVAL: <u>N/A</u>	
<input checked="" type="checkbox"/> SIDEWALK* <input type="checkbox"/> BIKE LANE <input type="checkbox"/> OTHER		SQ FT OF SIDEWALK RECONSTRUCTION*: <u>N/A</u>	
TRANSIT STOP? <input type="checkbox"/> Y <input type="checkbox"/> N PARKING LANE(S)** <input type="checkbox"/> Y <input type="checkbox"/> N **NON-METERED		*CONCRETE OR ASPHALT SIDEWALK/PATH BEING IMPROVED/REPLACED	
START DATE: <u>Mar 3rd</u> END DATE: _____ # OF DAYS*: <u>30</u>		SQ FT OF SIDEWALK NEW CONSTRUCTION*: <u>N/A</u>	
STREET NAME 2: _____		*CONCRETE OR ASPHALT SIDEWALK/PATH THAT IS NEW INFRASTRUCTURE	
1ST INTERSECTING STREET NAME: _____		#RESIDENTIAL DRIVEWAY INSTALLATION: <u>N/A</u>	
2ND INTERSECTING STREET NAME: _____		 <p>TO SUBMIT A LOCATE REQUEST 24 HRS A DAY, 7 DAYS A WEEK CALL 811 OR 800-382-5544 CALL 2 WORKING DAYS BEFORE YOU DIG. IT'S THE LAW.</p>	
<input type="checkbox"/> ROAD CLOSURE <input type="checkbox"/> LANE CLOSURE 1 <input type="checkbox"/> 2 <input type="checkbox"/> 3 <input type="checkbox"/>			
<input type="checkbox"/> SIDEWALK* <input type="checkbox"/> BIKE LANE <input type="checkbox"/> OTHER		<b>H. INDEMNIFICATION AGREEMENT:</b>	
TRANSIT STOP? <input type="checkbox"/> Y <input type="checkbox"/> N PARKING LANE(S)** <input type="checkbox"/> Y <input type="checkbox"/> N **NON-METERED		The petitioner/applicant hereby agrees to hold harmless, defend and to indemnify the City of Bloomington from or against all claims, action, damages and expenses, including but not limited to reasonable attorney's fees or any alleged injury and/or death to any person or damage to any property arising, or alleged to have arisen out of any act of commission or omission on the part of the petitioner/applicant, his/her heirs, successors, or assigns regardless of whether such acts are the direct or indirect result of the public right-of-way use pursuant to this permit grant.	
START DATE: _____ END DATE: _____ # OF DAYS*: _____		I AFFIRM, UNDER THE PENALTIES FOR PERJURY, THAT THE FOREGOING REPRESENTATIONS ARE TRUE.	
*SIDEWALK CLOSURES FOR A PERIOD OR PERIODS TOTALING 24HRS OR MORE SHALL INSTALL A WALKAROUND UNLESS OTHERWISE APPROVED DURING REVIEW		PRINT NAME: <u>Bret Simons</u>	
<b>STANDARD CLOSURE HOURS MON-FRI*: 9:00 AM - 3:00 PM &amp; 6:00 PM - 9:00 PM</b>		SIGNATURE: <u>Bret Simons</u>	
STANDARD CLOSURE HOURS <input checked="" type="checkbox"/> *NON-STANDARD CLOSURE HOURS <input type="checkbox"/>		DATE: <u>2/10/2023</u>	
REQUESTED CLOSURE HOURS: _____ AM - _____ PM			
*non-standard hours may not be allowed near schools, on arterials, or other circumstances and are subject to approval during the permitting process			
BMC 14.09.040 allows work from 6 AM to 10 PM without violating the noise ordinance (7AM to 9PM for pneumatic hammers)			

For Administration Use Only (applicable to CLOSURE approval)

Approved By: \_\_\_\_\_  BPW  City Engineer  Director Date: \_\_\_\_\_

Staff Representative: \_\_\_\_\_ Phone#: \_\_\_\_\_ Date: \_\_\_\_\_





## Board of Public Works Staff Report

---

**Project/Event:** Student Involvement and Leadership Center

**Petitioner/Representative:** Julie Comer/ Terese Weimann

**Staff Representative:** April Rosenberger

**Meeting Date:** February 28, 2023

---

The Student Involvement and Leadership Center is requesting permission to close 7th Street between Indiana Avenue and N. Woodlawn Ave. to host an IU Bloomington Carnival featuring large carnival rides, food trucks, live music, games, prize giveaways for IU students and their guests to celebrate the end of the semester.

---

**CITY OF BLOOMINGTON  
BOARD OF PUBLIC WORKS  
RESOLUTION 2023-09**

**Indiana University Carnival**

WHEREAS, the Board of Public Works is empowered by I.C. 36-9-6-2 to supervise city streets; and

WHEREAS, The Student Involvement and Leadership Center is desirous of using East 7<sup>th</sup> Street from Indiana Avenue to N. Woodlawn Avenue for a Carnival on Friday, April 14, 2023 from 6:00 p.m. until 12:00 a.m.

NOW, THEREFORE, BE IT RESOLVED THAT:

1. The City of Bloomington Board of Public Works declares that East 7<sup>th</sup> Street from Indiana Avenue to N. Woodlawn Avenue shall be temporarily closed for a Carnival on Friday, April 14, 2023 from 7:00 a.m. until Saturday, April 15, 2023 at 3:00 a.m. for the purpose of staging a Carnival with the actual event being on Friday, April 14, 2023 between the hours of 6:00 p.m. to 12:00 a.m. No rain date is planned for this event.
2. The Student Involvement and Leadership Center shall work with City of Bloomington Parking Enforcement regarding a requested closure of any parking spaces. Parking Enforcement shall post "No Parking" signs at appropriate parking spaces at least 24 hours in advance of their closure.
3. The Student Involvement and Leadership Center shall be responsible for developing a Traffic Plan to be approved by the Engineering Department. The Student Involvement and Leadership Center shall obtain, and place at T The Student Involvement and Leadership Center 's own expense, any security measures which are deemed prudent and necessary by the Police Department which may include, but are not limited to: anti-vehicle barriers or protection; pedestrian barriers; and other engineering controls or personnel as deemed appropriate. The Student Involvement and Leadership Center agrees to close the streets not before 7:00 a.m. on Friday, April 14, 2023 and to remove barricades and signage by 3:00 a.m. on Saturday, April 15, 2023.
4. The Sponsor shall be responsible for obtaining any and all required permits as well as being responsible for all legal and financial expenditures.
5. The Sponsor shall be responsible for notifying the general public, public transit and public safety agencies of the street closing by notice at least 48 hours in advance.
6. By granting permission to utilize City property to facilitate this activity, the City also waives the City Noise Ordinance in accordance with Section 14.09.070 of the Bloomington Municipal Code, and therefore amplified sound and music may be played during the event.
7. The Sponsor agrees to clean up the street both before and after the event. The clean-up shall include but not be limited to removal of any food or drink residue, picking up litter, sweeping any broken glass, and emptying and removal of trash cans. Clean-up after the event shall be completed by 3:00 a.m.
8. In consideration for the use of the City's property and to the fullest extent permitted by law, The Student Involvement and Leadership Center, for itself, its officers, directors, agents, employees, members,

successor and assigns, does hereby indemnify and hold harmless the City of Bloomington, the Board, and the officers , agents, and employees of the City and the Board from any and all claims, demands, damages, costs, expenses or other liability arising out of bodily injury or property damage (collectively “Claims”) which may occur as a result of the use of said property, including, but not limited to, any claim of claims brought by third parties, whether or not sounding in tort or contract.

9. By signing this agreement, \_\_\_\_\_, represents that he/she has been fully empowered by proper action of the entity to enter into the agreement and has authority to do so.

ADOPTED THIS 28<sup>TH</sup> DAY OF FEBRUARY, 2023

\_\_\_\_\_  
Kyla Cox Deckard, President

\_\_\_\_\_  
Signature  
Indiana University Student Involvement  
and Leadership Center

\_\_\_\_\_  
Elizabeth Karon, Vice President

Date: \_\_\_\_\_

\_\_\_\_\_  
Jennifer Lloyd, Secretary



**JOHN HAMILTON**

**MAYOR DEPARTMENT OF PUBLIC WORKS DEPARTMENT OF ECONOMIC**

**CITY OF BLOOMINGTON & SUSTAINABLE DEVELOPMENT 401 N Morton St Suite 150 ESD 812.349.3418 PO Box 100 PW 812.349.3411 Bloomington IN 47402**

Greetings from the City of Bloomington!

This application is for approval from the Board of Public Works for Temporary Special Events for the use of public rights of way owned by the City of Bloomington. To assure timely approval by the Board of Public Works to your application we ask that you notify us three (3) months in advance.

Applications will not be considered unless all relevant portions of the application have been completed in their entirety. Once a completed application is submitted to the City it will be reviewed by City Staff and will then go before the Board of Public Works for consideration. Once approved by the Board of Public Works, the City retains the right to revoke permission if event becomes a public safety concern.

The Board of Public Works has the sole discretion as to whether or not a special approval shall be granted. If the Board of Public Works issues a special approval for use of public right-of-way the Board may prescribe any reasonable conditions or requirements it deems necessary to minimize the adverse effects upon the Bloomington community, surrounding neighborhoods, or emergency service providers.

If the Board of Public Works issues the special approval, the permit holder shall still abide by all other city, county, state and federal laws.

The City of Bloomington  
Department of Economic and Sustainable Development



**CITY OF BLOOMINGTON**

**SPECIAL EVENT APPLICATION**

**City of Bloomington  
Department of Economic and Sustainable Development  
401 N. Morton Street, Suite 150  
Bloomington, Indiana 47404  
812-349-3418  
Department of Public Works  
812-349-3411**

**1. APPLICANT INFORMATION**

Contact Name:	Julle Comer		
Contact Phone:		Mobile Phone:	317-800-4487

Title/Position:	Program Manager Intern		
Organization:	Student Involvement and Leadership Center - Indiana Memorial U		
Address:	900 E 7th St		
City, State, Zip:	Bloomington, IN 47405		
Contact E-Mail Address:	jncomer@iu.edu		
Organization E-Mail and URL:	<a href="mailto:sil@indiana.edu">sil@indiana.edu</a> <a href="https://studentaffairs.indiana.edu/get-involved/index.html">https://studentaffairs.indiana.edu/get-involved/index.html</a>		
Org Phone No:	812-855-4682	Fax No:	

## 2. ANY KEY PARTNERS INVOLVED (including Food Vendors if applicable)

Organization Name:	Local Bloomington Food Trucks - actual trucks TBD		
Address:			
City, State, Zip:			
Contact E-Mail Address:			
Phone Number:		Mobile Phone:	
Organization Name:	Indiana University Catering		
Address:	900 E 7th St		
City, State, Zip:	Bloomington, IN 47405		
E-Mail Address:	iucater@indiana.edu		
Phone Number:		Mobile Phone:	
Organization Name:	Indiana Memorial Union Board & Bloomington Delta Music		
Address:	900 E 7th St		
City, State, Zip:	Bloomington, IN 47405		
E-Mail Address:	lfb@indiana.edu		
Phone Number:		Mobile Phone:	

## 3. EVENT INFORMATION



Type of Event	<input type="checkbox"/> Metered Parking Space(s) <input type="checkbox"/> Run/Walk <input checked="" type="checkbox"/> Festival <input type="checkbox"/> Block Party <input type="checkbox"/> Parade <input type="checkbox"/> Art in the Right of Way <input type="checkbox"/> Other (Explain below in Description of Event)	
Date(s) of Event:	April 14th, 2023 Rain Date: April 21, 2023	
Time of Event:	Date: 4/14/23 Start: 6:00pm Date: 4/14/23 End: 12:00am	
Setup/Teardown time Needed	Date: 4/14/23 Start: 7am Date: 4/14/23 End: 3am Rain Date times for set-up/tear down are the same	
Calendar Day of Week:	Friday	
Description of Event:	An IU Bloomington carnival featuring large carnival rides, food trucks, live music, games, prize giveaways- this would be for IU students and their guests to celebrate the end of the semester	
Expected Number of Participants:	3,000	Expected # of vehicles (Use of Parking Spaces to close): N/A

**4. IF YOUR EVENT IS A NEIGHBORHOOD BLOCK PARTY, YOU ARE REQUIRED TO SECURE AND ATTACH THE FOLLOWING:**

<input type="checkbox"/>	A map of the proposed rights-of-way closure or route in its entirety (streets shall be properly labeled and identified) <ul style="list-style-type: none"> <li>• The starting point shall be clearly marked</li> <li>• The ending point shall be clearly marked</li> <li>• Each intersection along the route shall be clearly identified</li> <li>• A notation of how each intersection is to be blocked shall be specifically noted at each intersection (where type 3 barricades will be placed)</li> </ul>
<input type="checkbox"/>	Notification to businesses/residents that will be impacted by event (copy of notification letter/flyer/other)
<input type="checkbox"/>	A properly executed Maintenance of Traffic Plan <ul style="list-style-type: none"> <li>• Determine if No Parking Signs will be required</li> </ul>
<input type="checkbox"/>	Noise Permit application

**5. IF YOUR EVENT IS A RUN/WALK/PARADE, YOU ARE REQUIRED TO SECURE AND ATTACHED THE FOLLOWING: Moving Events – Use and/or Closure of City Streets/Sidewalks**

<input type="checkbox"/>	<p>A map of the proposed rights-of-way closure or route in its entirety (streets shall be properly labeled and identified)</p> <ul style="list-style-type: none"> <li>• The starting point shall be clearly marked</li> <li>• The ending point shall be clearly marked</li> <li>• The number of lanes to be restricted on each road shall be clearly marked</li> <li>• Each intersection along the route shall be clearly identified</li> <li>• A notation of how each intersection is to be blocked shall be specifically noted at each intersection (i.e.: Type 3 barricades and/or law enforcement); and</li> <li>• The location of any staging area(s) for the rights-of-way closure and how much space the staging area(s) shall utilize</li> </ul>
<input type="checkbox"/>	Notification to businesses /residents that will be impacted by event of the day the application will be heard by Board of Public Works (Example attached)
<input type="checkbox"/>	Using a City park or trail? Parks & Recreation Department Approved Special Use Permit ☞ Not applicable
<input type="checkbox"/>	Certificate of Liability Insurance – Proof of insurance listing the City of Bloomington as additional insured for an amount no less than \$1,000,000 per occurrence and \$2,000,000 in the aggregate. DEADLINE: To Public Works no later than five days before event.
<input type="checkbox"/>	A properly executed Maintenance of Traffic Plan *Determine if No Parking Signs will be required * Determine if Barricades will be required
<input type="checkbox"/>	Secured a Parade Permit from Bloomington Police Department ☞ Not applicable
<input type="checkbox"/>	Noise Permit application ☞ Not applicable
<input type="checkbox"/>	Waste and Recycling Plan if more than 100 participates (template attached)

**6. IF YOUR EVENT IS A FESTIVAL/SPECIAL COMMUNITY EVENT YOU ARE REQUIRED TO SECURE AND ATTACH, AND SUBMIT THE FOLLOWING: Stationary Events – Closure of Streets/Sidewalks/Use of Metered Parking**

<input checked="" type="checkbox"/>	<p>A map of the proposed rights-of-way closure in its entirety (streets shall be properly labeled and identified)</p> <p>The starting point shall be clearly marked</p> <ul style="list-style-type: none"> <li>• The ending point shall be clearly marked</li> <li>• The number of lanes to be restricted on each road shall be clearly marked</li> <li>• Each intersection along the route shall be clearly identified</li> <li>• A notation of how each intersection is to be blocked shall be specifically noted at each intersection (ie: type 3 barricades and/or law enforcement); and</li> <li>• The location of any staging area(s) for the rights-of-way closure and how much space the staging area(s) shall utilize</li> </ul>
<input checked="" type="checkbox"/>	Notification to business/residents who will be impacted by event of the day the application will be heard by Board of Public Works (Example attached)
<input checked="" type="checkbox"/>	Using a City park or trail? Parks & Recreation Department Approved Special Use Permit ✓ Not applicable
<input checked="" type="checkbox"/>	A properly executed Maintenance of Traffic Plan *Determine if No Parking Signs will be required * Determine if Barricades will be required

✓	Noise Permit application ( ) Not applicable
✓	Beer & Wine Permit ✓ Not applicable
✓	Certificate of Liability Insurance listing the City of Bloomington as additional insured. For an amount not less than \$1,000,000 per occurrence and \$2,000,000 in the aggregate. <b>DEADLINE:</b> To Public Works no later than five days before event.
✓	If Food Vendors are part of Festival (Monroe County Health Department Licenses & Fire Inspection)
✓	Waste and Recycling Plan if more than 100 participates (template attached)

## 7. CHECKLIST

✓	Determine type of Event
✓	Complete application with attachment: <ul style="list-style-type: none"> <li>✓ Detailed Map</li> <li>✓ Proof of notification to businesses/residents (copy of letter/flyer/other)</li> <li>✓ Maintenance of Traffic Plan</li> <li>✓ Noise Permit Application (if applicable)</li> <li>✓ Certificate of Liability Insurance</li> <li>✓ Secured a Parade Permit from Bloomington Police Department (if applicable)</li> <li>✓ Beer and Wine Permit (if applicable)Waste and Recycling Plan (if applicable)</li> <li>✓ Waste and Recycling Plan (if applicable)</li> <li><input type="checkbox"/> For art installations: an accurate depiction of the design of private art to scale, dimensions of the art, placement on the detailed map of proposed location of the art, and the name and qualifications of the artist</li> </ul>
✓	Date Application will be heard by Board of Public Works
✓	Approved Parks Special Use Permit (if using a City Park)
✓	If using food vendors assure proper paperwork in order (Monroe County Health Department Licenses & Fire Inspection)
✓	If applicable, acknowledgment of compliance with the City of Bloomington Policy and Procedures on Private Art Installations within the Public Right of Way (Policy attached with application)

## FOR CITY OF BLOOMINGTON USE ONLY

Date Received:	Received By:	Date Approved:	Approved By:
	Economic & Sustainable Development		
	Bloomington Police		
	Bloomington Fire		
	Engineering		
	Transit		

# 10 Carnival - Option B of closures

## For City Of Bloomington Use Only

Date Received:	Received By:	Date Approved:	Approved By:
2/9/23	Public Works		
	Board of Public Works		
	Bloomington Police	2/16/23	MW - Option B
	Bloomington Fire	2/16/23	TC - Option B
	Economic & Sustainable Development	2/16/23	De - Option B
	Engineering		
	Office of The Mayor	2/16/23	KG - Option B
	Parking Enforcement		
	Utilities	2/16/23	Jane
	Transit		

	Office of the Mayor		
	Utilities		
	Public Works		
	Board of Public Works		



## NOISE PERMIT

City of Bloomington  
 401 N. Morton St., Suite 120  
 Bloomington, Indiana 47404  
 812-349-3411

### Application and Permit Information

This is an application for a permit for relief from Chapter 14.09 (Noise Control) of the Bloomington Municipal Code. Any permit granted by the City of Bloomington must contain all conditions upon which said permit shall be effective. The City may prescribe any reasonable conditions or requirements it deems necessary to minimize adverse effects upon the community or the surrounding neighborhood.

Once a completed application is submitted to the City, it will be reviewed by the Board of Public Works. If the permit is approved, the holder must still abide all other city, state, and federal laws.

Contact April Rosenberger with any questions: (812) 349-3411 or [april.rosenberger@bloomington.in.gov](mailto:april.rosenberger@bloomington.in.gov)

### Event and Noise Information

Name of Event:	IU Late Nite Carnival			
Location of Event:	900 E 7th St			
Date of Event:	April 14th, 2023	Time of Event:	Start: 8:00pm	
Calendar Day of Week:	Friday		End: 1:00am	
Description of Event:	An IU Bloomington carnival featuring large carnival rides, food trucks, live music, games, prize giveaways- this would be for IU students and their guests to celebrate the end of the semester			
Source of Noise:	Live Band <b>Bloomington Delta Music Group</b>	Instrument <b>Yes</b>	Loudspeaker <b>Yes</b>	Will Noise be Amplified? <b>Yes</b> No
Is this a Charity Event?	Yes <b>No</b>	If Yes, to Benefit:		

### Applicant Information

Name:	Julle Comer
-------	-------------

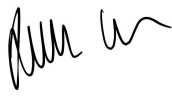

Organization:	Indiana Memorial Union Student Involvement and Leadership Center	Title:	SILC Program Manager Intern
Physical Address:	900 E 7th St		
Email Address:	jncomer@iu.edu	Phone Number:	317-800--4487
Signature:		Date:	2/20/2023

**FOR CITY OF BLOOMINGTON USE ONLY**

**In accordance with Section 14.09.070 of the Bloomington Municipal Code, We, the Board of Public Works, the designee of the Mayor of the City of Bloomington, hereby waive the City Noise Ordinance for the above mentioned event.**

<b>BOARD OF PUBLIC WORKS</b>	
Kyla Cox Deckard, President	Elizabeth Karon, Vice-President
	Jenifer Lloyd, Secretary
Date	

## Waste and Recycling Management Plan Template

Event name: IU Late Nite Carnival

Number of expected attendees: 3,000

Number of food vendors: 8 food trucks, IMU Catering and possibly two other vendors to serve “carnival like” food options

Number of other vendors: 6– Carnival Ride Vendor, Carnival Game Vendor, Tent/Table/Chair Vendor, Porta-Pottie Vendor, Production Vendor, Photo Booth Vendor

**Designated waste and recycling manager:** Event Logistics Lead: Julie Comer

**Event map:** In the event map you submit with your event application, please clearly designate where waste and recycling bins will be placed. Each waste bin should be paired with one or more recycling bins. Also designate any larger collection areas (such as dumpsters) and the path for access by waste haulers.

**TIP:** Recycling bins should be visually distinct from waste bins, and all bins should be clearly labeled for easy use by attendees.

ClearStream recycling bins are available for use through [Downtown Bloomington, Inc.](#)

**Targeted waste:** Please enumerate the types of waste expected at the event and plans for collecting each type of item using the following table. Examples are listed, but feel free to modify as appropriate.

Type of waste	Collection plan
---------------	-----------------

Trash from food containers;	Recycling bins for cans/bottle 1 per 300 people; trash bins 1 per 100 people– all provided by IU Facilities
n/a	n/a
<Food waste>	Waste bins (see above)

\*Note that “compostable” plastics are only compostable in industrial composters, which are not available in the Bloomington area. If you opt for compostable items at your event, ensure that they are compostable paper rather than plastic.

**Collection and hauling system:** IU Facilities will handle the disposing of waste and the recycling. There will be signage throughout the venue helping guests locate the closest recycling and/or waste bin. Volunteers will also be helping guests locate the closest recycling and/or waste bin. Announcements throughout the live music will also remind guests that there are both waste bins and recycling bins.

Events with over 100 attendees must provide staffed (by paid staff or volunteers) waste management stations to ensure that materials are separated according to the waste and recycling management plan. This will be done through IU facilities

**Vendor and volunteer education and training:** During volunteer training prior to the event, information on the waste and recycling management will be shared. Vendors will also receive this information prior to the start of the event.

**Materials and supplies:** Signage throughout the the venue and recycling bins ( 1 per 300) and waste bins (1 per 100) throughout the venue and located in high traffic areas. We will have buttons made as part of our “uniform” reminding folks to recycle

**Designation of duties:** Volunteer coordinator will be educating the volunteers, Logistics coordinator will be in charge of placement of bins and education of vendors.

## Certificate of Liability

**We will provide a Certificate of Liability no later than 5 days prior to the event.**

## Security

**We will work with IUPD and CSC to ensure the safety of all attendees.**

## Food Vendors

**Food Vendors will be IMU Catering, Local Approved by IU Food Truck**

**Vendors, and one additional vendor to provide “carnival-like” food approved by IU.**

**EXAMPLE: NOTICE OF PUBLIC MEETING LETTER**

The Board of Public Works of Bloomington, Indiana, has been petitioned to hear a request for a Special Event in Public Right Way for .

The Board of Public Works meeting to hear this request will be February 28, 2023. Board of Public Works meetings are held in the Council Chambers of the Showers City Hall at 401 N. Morton at 5:30 p.m. Meeting are also broadcast via Zoom; Zoom information can be found the Board of Public Works web page at <https://bloomington.in.gov/boards/public-works>, or you may also call 812.349.3411 for this information.

The proposal for will be on file and may be examined in the Public Works office on the Friday (insert date) prior to the Tuesday (insert) meeting.

All persons interested in said proposal may be heard at the time and place as herein set out. If you would rather voice your opinion by phone you may call 812.349.3410 or email [public.works@bloomington.in.gov](mailto:public.works@bloomington.in.gov). Written and verbal objections filed with the Board of Public Works prior to the hearing will be considered.

**BOARD OF PUBLIC WORKS  
CITY OF BLOOMINGTON, INDIANA**

PETITIONER:  
DATE:

<b>Contact Information- Other</b>			
	<b><u>Location</u></b>	<b><u>Contact</u></b>	<b><u>Phone Number</u></b>
Maintenance of Traffic Plan	401 N. Morton St. Suite 130 Bloomington, IN	City of Bloomington Planning & Transportation	(812)349-3423
Monroe County Health Department (Food Handler Permit)	119 W. 7th St. Bloomington, IN	County Health Department Food Sanitarian	(812) 349-2543
Waste & Recycling Plan	401 N. Morton Street Suite 150	Lauren Clemens Economic & Sustainable Development	(812) 349.3837

Bloomington Board of Public Works	401 N. Morton St. Suite 120 Bloomington, IN	April Rosenbarger Dept. of Public Works	(812) 349-3411
Economic and Sustainable Development (Arts)	401 N. Morton St. Suite 150 Bloomington, IN	Holly Warren Arts Director	(812) 349-3618
Bloomington Parks and Recreation Department (Events on City of Bloomington Parks Property)	401 N. Morton St. Suite 250 Bloomington, IN	Leslie Brinson Community Events Manager	(812) 349-3700
Bloomington Fire Department  (If event will have any kind of open	300 E. 4th St. Bloomington, IN	Fire Administration	(812) 332-9763
Bloomington Police Department (Parade Permit)	220 E. Third Bloomington, IN	Police Administration	(812) 339-4477
Master Rental	2022 W. 3 <sup>rd</sup> Street Bloomington, IN	Type 3 Barricades	(812) 332-0600
Indiana Traffic Services	3867 N. Commercial Parkway Greenfield, IN 46140	Type 3 Barricades	(317) 891-8065
Monroe County Emergency Management	2800 S. Kirby Road Bloomington, IN		(812)- 349-2546
Department of Homeland Security		Mike Anderson	(317) 409-9510



## **City of Bloomington Policy and Procedures on Private Art**

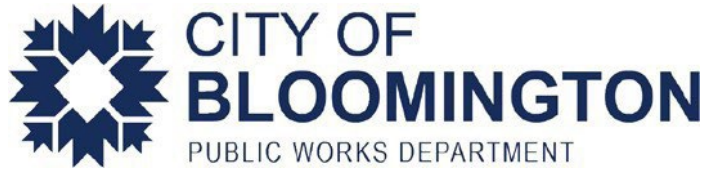

RE: Notice of Public Meeting

Dear Sir or Madam:

The Board of Public Works of Bloomington, Indiana, has been petitioned to hear a request for a Special Event in the Public Right Way for\_\_\_\_\_.

The Board of Public Works meeting to hear this request will be on\_\_\_\_\_at 5:30 PM. Board of Public Works meetings are held virtually via zoom and in person in the City of Bloomington Council Chambers at City Hall, 401 N. Morton Street, Bloomington, Room 115.

Zoom information for the meeting may be found on the Public Works web page at <https://bloomington.in.gov/boards/public-works> or you may also call 812.349.3411 for zoom information.

The proposal for this event will be on file and may be examined in the Public Works office on Friday,\_\_\_\_\_, prior to the Tuesday,\_\_\_\_\_meeting. All persons interested in said proposal may be heard at the time and place as herein set out. If you would rather voice your opinion by phone you may call 812.349.3411 or email [public.works@bloomington.in.gov](mailto:public.works@bloomington.in.gov). Written and verbal objections filed with the Board of Public Works prior to the hearing will be considered.

BOARD OF PUBLIC WORKS  
CITY OF BLOOMINGTON, INDIANA

Petitioner:

\_\_\_\_\_

Date:



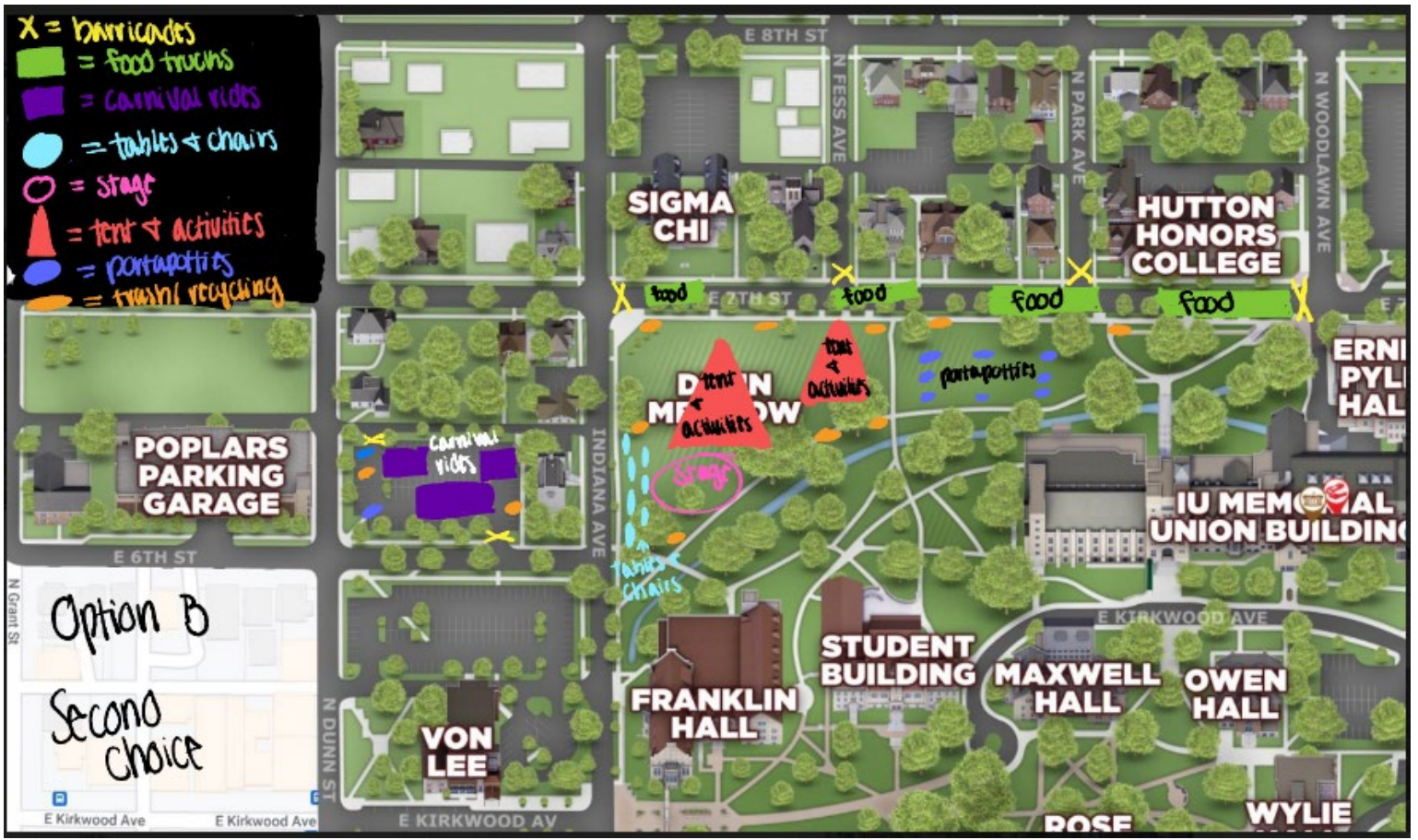

**Notification to Residents:**

**NOTICE OF PUBLIC MEETING LETTER**

The Board of Public Works of Bloomington, Indiana, has been petitioned to hear a request for a Special Event in Public Right Way for the Indiana University Student Involvement and Leadership Center’s Late Nite Carnival.

The Board of Public Works meeting to hear this request will be **MONTH, DAY, YEAR**. Board of Public Works meetings are held virtually via zoom. Zoom information can be found on the Public Works web page at <https://bloomington.in.gov/boards/public-works> or you may also call 812.349.3411 for this information.

The proposal for will be on file and may be examined in the Public Works **office on the Friday (insert date) prior to the Tuesday (insert)meeting.**

All persons interested in said proposal may be heard at the time and place as herein set out. If you would rather voice your opinion by phone you may call 812.349.3410 or email [public.works@bloomington.in.gov](mailto:public.works@bloomington.in.gov). Written and verbal objections filed with the Board of Public Works prior to the hearing will be considered.

BOARD OF PUBLIC WORKS  
CITY OF BLOOMINGTON, INDIANA



- X = barricades
- = food trucks
- = carnival rides
- = tables & chairs
- = stage
- ▲ = tent & activities
- = portapotties
- = trash/recycling

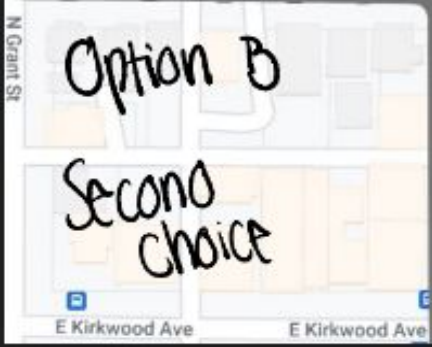

Option B

Second choice

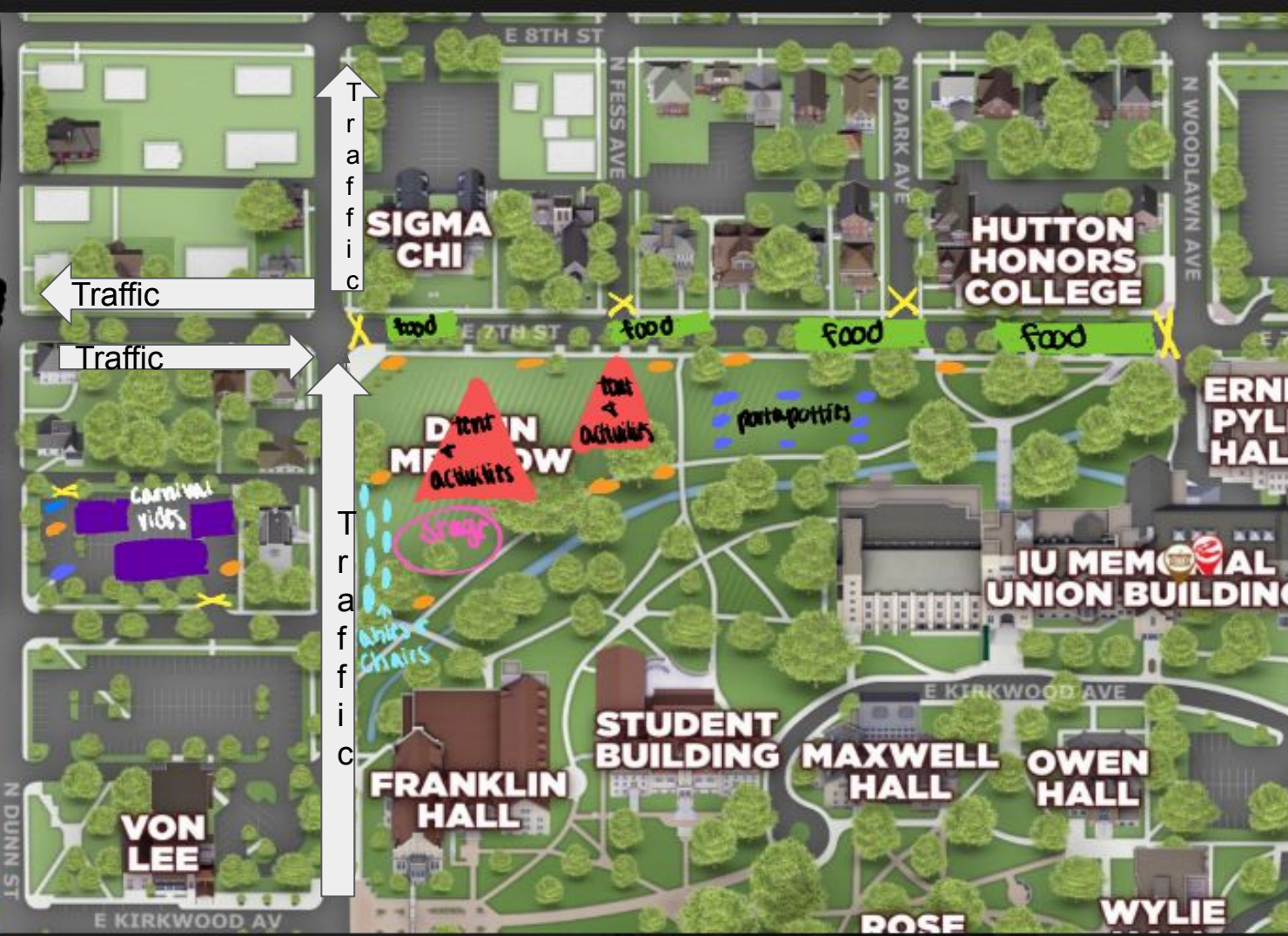

# **Installations within the Public Right of Way**

The City of Bloomington's Policy and Procedures on Private Art Installations within the Public Right of Way ("Policy") authorizes private Art Installations in the public right of way that comply with this document and are approved through one of two City programs: (1) the Neighborhood Improvement Grant Program or (2) a Special Event Application.

This Policy is designed to reduce the risks to public safety and burden on public resources that private Art Installations within the right of way may impose while simultaneously recognizing the importance of private as well as public art to Bloomington's culture, community, and economy.

I. Definitions. The following definitions shall apply throughout this policy.

- A. Temporary Art. Art expected to remain in place within the public right of way for seven (7) or fewer days.
- B. Semi-Permanent Art or Permanent Art. Art expected to remain in place within the public right of way for more than seven (7) days.
- C. Art Installation. Temporary, Semi-Permanent, or Permanent Art that consists of a physical alteration of the right of way, such as a painting, mural, or sculpture and that is not Performative Art.
- D. Street Painting or Street Mural. Art involving the placement of paint or a similar material within the area where vehicles drive or park, commonly understood to be the space "between the curbs."
- E. Performative Art. A time-based art form that is an ephemeral event featuring a live presentation to an audience, drawing on such arts as acting, poetry, music, or dance, and that does not involve the creation of an artifact (such as a painting or sculpture) that physically alters the right of way beyond the time of the live performance.
- F. Speech. Words, letters, numbers, universally recognized symbols, or logos of any kind.

II. Performative Art. This policy does not apply to Performative Art.<sup>1</sup>

III. Criteria Applicable to All Private Art Installations. The following criteria are applicable to any private Art Installation proposed within Bloomington's right of way, whether the Art Installation is Temporary Art, Semi-Permanent Art, or Permanent Art.

- A. Requests must be submitted to the appropriate City Department(s) and/or Board(s) or Commission(s), as required by the selected program application identified in Section VI below. Staff shall provide a recommendation on the request to the appropriate Board(s) or Commission(s) based on the request's compliance with this Policy and any other applicable laws, rules, or City of Bloomington policies.
- B. Art Installations may not use or incorporate copyrighted material in whole or part where the copyright is not owned by the artist.
- C. Art Installations may not mimic in whole or part traffic control devices including but not limited to a crosswalk, stop sign, stop bar, or similar traffic control device. Art Installation geometry should be such that drivers do not alter their course to drive around the art.
- D. Art Installations may not depict activities, materials, images, or products that are not legally available to all ages.

IV. Additional Criteria Applicable to Semi-Permanent Art Installations or Permanent Art Installations.

- A. Applications for approval of a Semi-Permanent or Permanent Art Installation within the right of way must include the following:
  - 1. An accurate depiction of the design to scale;
  - 2. Dimensions;
  - 3. A map of proposed location of the design; and
  - 4. The name and qualifications of the artist.

<sup>1</sup> Though this Policy does not apply to Performative Art taking place within the right of way, other municipal policies or ordinances may apply that impact Performative Art within the right of way, including but not limited to the City's parade ordinance or special event application process.

- B. Semi-Permanent Art Installations or Permanent Art Installations may not contain Speech.

V. Additional Criteria Applicable to Street Paintings or Street Murals. Because paintings and murals within the street create a heightened probability of conflicts with traffic control devices and driver distraction, the following additional criteria apply to all paintings or murals proposed for street surfaces, whether as Temporary, Semi-Permanent, or Permanent Art Installations.

- A. Applications for approval of a Street Painting or Street Mural within the right of way must include the following:

1. An accurate depiction of the design to scale;
  2. Dimensions;
  3. A map of proposed location of the design; and
  4. The name and qualifications of the artist.
- B. Street paintings and street murals may only be placed on streets with a local or secondary collector functional classification under the City's Transportation Plan, where regulatory speed limits do not exceed 25 miles per hour.
- C. Street paintings and street murals may only be placed on pavement in adequate condition for materials to bond.
- D. Street paintings and street murals are not permitted on brick, paver, or other decorative surface materials (e.g., colored or stamped concrete). Street paintings and street murals are only permitted on standard non-decorative concrete or asphalt.
- E. A buffer of four feet must remain between street paintings and street murals and any crosswalk.
- F. Within an intersection, street paintings and street murals are only allowed where the intersection utilizes all-way stop control, unless the painting or mural is located on an apron.
- G. Street paintings and street murals may not be painted on the side or top of any curb or any curb ramp.
- H. Materials used must be approved by the City's Engineering Department.

3

- I. Any paint or similar material utilized as part of any street painting or street mural must provide a non-slip surface for pedestrians and must be street-grade.

VI. Programs. Individuals and external organizations seeking to place private Art Installations within the public right of way must apply pursuant to one of the programs listed below and follow the procedures associated with the program, which are linked and attached hereto for reference. Requests to place an Art Installation in the City's right of way using a program or procedure other than those listed below will not be considered.

A. Neighborhood Improvement Grant Program

1. Applications for Art Installations within the right of way pursuant to the Neighborhood Improvement Grant Programs must comply with Program



guidelines, the criteria set forth in this Policy, and any additional logistical or safety conditions imposed by the Board of Public Works as part of its approval.

2. Neighborhood Improvement Grant Program guidelines may be accessed [here](#)<sup>2</sup> and are attached for reference.

#### B. Special Event Permit

1. A special event application may be submitted for permission to conduct an event during which an Art Installation will be placed in the public right of way. The proposed Art Installation must comply with the criteria set forth in this policy, the requirements set forth in the special event permit application, and any additional logistical or safety conditions imposed by the Board of Public Works as part of its approval.
2. A special event application may be accessed [here](#)<sup>3</sup> and is attached for reference.

<sup>2</sup> <https://bloomington.in.gov/neighborhoods/grants/improvement>

<sup>3</sup> <https://bloomington.in.gov/departments/esd>



# Board of Public Works Claim Register

Invoice Date Range 02/18/23 - 03/03/23

Vendor	Invoice Description	Received Date	Payment Date	Invoice Amount
<b>Fund 101 - General Fund (S0101)</b>				
Department <b>01 - Animal Shelter</b>				
Program <b>010000 - Main</b>				
Account <b>43430 - Animal Adoption Fees</b>				
Oscar Flores	01-refund adoption fee/rabies vac-2/7/23		03/03/2023	75.00
	Account <b>43430 - Animal Adoption Fees</b> Totals		Invoice 1 Transactions	<u>\$75.00</u>
Account <b>43442 - Equipment Deposits</b>				
Jon Williams	01-Refund trap deposit-2/11/23		03/03/2023	40.00
	Account <b>43442 - Equipment Deposits</b> Totals		Invoice 1 Transactions	<u>\$40.00</u>
Account <b>43460 - Medical</b>				
Oscar Flores	01-refund adoption fee/rabies vac-2/7/23		03/03/2023	15.00
	Account <b>43460 - Medical</b> Totals		Invoice 1 Transactions	<u>\$15.00</u>
Account <b>52210 - Institutional Supplies</b>				
7508 - Elanco US INC	01-antiparasitics		03/03/2023	383.76
4586 - Hill's Pet Nutrition Sales, INC	01-Dog & Cat Food		03/03/2023	110.88
4549 - Kroger Limited Partnership I	01-Rabbit Food & Shelter Supplies		03/03/2023	32.25
4633 - Midwest Veterinary Supply, INC	01-Veterinary Medication & Supplies		03/03/2023	632.79
4633 - Midwest Veterinary Supply, INC	01-Veterinary Supplies-syringes		03/03/2023	74.55
4633 - Midwest Veterinary Supply, INC	01-Veterinary Supplies		03/03/2023	128.92
4633 - Midwest Veterinary Supply, INC	01-Veterinary Supplies-antibiotics		03/03/2023	197.75
4633 - Midwest Veterinary Supply, INC	01-Veterinary Supplies		03/03/2023	625.76



# Board of Public Works Claim Register

Invoice Date Range 02/18/23 - 03/03/23

Account <b>52210 - Institutional Supplies</b> Totals		Invoice 8	\$2,186.66
Account <b>52340 - Other Repairs and Maintenance</b>		Transactions	
313 - Fastenal Company	01-Cleaning & Shelter Supplies-vehicle brush heads	03/03/2023	77.26
Account <b>52340 - Other Repairs and Maintenance</b> Totals		Invoice 1	\$77.26
Account <b>52420 - Other Supplies</b>		Transactions	
6222 - Apple, INC	01-Power Adaptor for Phone	03/03/2023	19.00
6222 - Apple, INC	01-Square Reader	03/03/2023	49.95
Account <b>52420 - Other Supplies</b> Totals		Invoice 2	\$68.95
Account <b>53130 - Medical</b>		Transactions	
8424 - Pipsqueakery INC (The Pipsqueakery)	01-Rabbit Spay/Neuter & Other Surgeries-11/8/22-1/26/23	03/03/2023	1,180.00
54639 - Shake Veterinary Services, INC (Town & Country Vet	01-Veterinary Diagnostics & Surgeries & spay/neutor	03/03/2023	270.00
Account <b>53130 - Medical</b> Totals		Invoice 2	\$1,450.00
Account <b>53610 - Building Repairs</b>		Transactions	
321 - Harrell Fish, INC (HFI)	01-SA Repaired Outdoor Kennel Drains	BC 2022-116 03/03/2023	535.00
Account <b>53610 - Building Repairs</b> Totals		Invoice 1	\$535.00
Account <b>53640 - Hardware and Software Maintenance</b>		Transactions	
4464 - Volgistics, INC	01-Volunteer Management Software-3/14/23-3/13/24	03/03/2023	1,800.00
Account <b>53640 - Hardware and Software Maintenance</b> Totals		Invoice 1	\$1,800.00
Program <b>010000 - Main</b> Totals		Transactions	
Department <b>01 - Animal Shelter</b> Totals		Invoice 18	\$6,247.87
Department <b>04 - Economic &amp; Sustainable Dev</b>		Transactions	
Program <b>040000 - Main</b>		Invoice 18	\$6,247.87
		Transactions	



# Board of Public Works Claim Register

Invoice Date Range 02/18/23 - 03/03/23

**Account 53910 - Dues and Subscriptions**

7656 - Brightly Software, INC

04-Energy Management Software renewal-2023	03/03/2023	12,936.00
Account <b>53910 - Dues and Subscriptions</b> Totals	Invoice 1	<u>\$12,936.00</u>
	Transactions	

**Account 53960 - Grants**

51483 - Downtown Bloomington, INC

04: Funds for Several Downtown pubic art installations	03/03/2023	10,000.00
Account <b>53960 - Grants</b> Totals	Invoice 1	<u>\$10,000.00</u>
Program <b>040000 - Main</b> Totals	Transactions	
	Invoice 2	<u>\$22,936.00</u>
	Transactions	

**Program 04RCVR - Recover Foward**

**Account 53960 - Grants**

7204 - Purdue University

04-Farm to School Program (Purdue Ext)-A. Abbott	03/03/2023	2,213.20
Account <b>53960 - Grants</b> Totals	Invoice 1	<u>\$2,213.20</u>
Program <b>04RCVR - Recover Foward</b> Totals	Transactions	
	Invoice 1	<u>\$2,213.20</u>
	Transactions	

**Program 04WALD - Waldron Arts Center**

**Account 53610 - Building Repairs**

393 - Kone INC

04-WALDRON Elevator - door detectors-Aug 2022	03/03/2023	65.00
---	------------	-------

393 - Kone INC

04-WALDRON Elevator - door detectors-Sept 2022	03/03/2023	65.00
--	------------	-------

393 - Kone INC

04-WALDRON Elevator - door detectors-Oct 2022	03/03/2023	65.00
---	------------	-------

393 - Kone INC

04-WALDRON Elevator-door detectors/Maint Period-Nov 2022	03/03/2023	250.00
--	------------	--------

393 - Kone INC

04-WALDRON Elevator-door detectors/Maint Period-Dec 2022	03/03/2023	250.00
--	------------	--------

Account <b>53610 - Building Repairs</b> Totals	Invoice 5	<u>\$695.00</u>
	Transactions	

**Account 53990 - Other Services and Charges**

6515 - Green Camino, INC (Earthkeepers)

04-Composting Service Agreement-2/6/23	03/03/2023	390.00
--	------------	--------



# Board of Public Works Claim Register

Invoice Date Range 02/18/23 - 03/03/23

Account <b>53990 - Other Services and Charges</b> Totals	Invoice 1	\$390.00
	Transactions	
Program <b>04WALD - Waldron Arts Center</b> Totals	Invoice 6	\$1,085.00
	Transactions	
Department <b>04 - Economic &amp; Sustainable Dev</b> Totals	Invoice 9	\$26,234.20
	Transactions	

Department **05 - Common Council**

Program **050000 - Main**

Account **52110 - Office Supplies**

6530 - Office Depot, INC	05- Name plate stands	03/03/2023	88.59
6530 - Office Depot, INC	05-office chairs, clocks, lamp	03/03/2023	775.60
	Account <b>52110 - Office Supplies</b> Totals	Invoice 2	\$864.19
		Transactions	
	Program <b>050000 - Main</b> Totals	Invoice 2	\$864.19
		Transactions	
	Department <b>05 - Common Council</b> Totals	Invoice 2	\$864.19
		Transactions	

Department **06 - Controller's Office**

Program **060000 - Main**

Account **52110 - Office Supplies**

5103 - Staples Contract & Commercial, INC	06-Fellowes shredder bags for model C125ci (20 gal)	03/03/2023	38.46
	Account <b>52110 - Office Supplies</b> Totals	Invoice 1	\$38.46
		Transactions	
	Program <b>060000 - Main</b> Totals	Invoice 1	\$38.46
		Transactions	
	Department <b>06 - Controller's Office</b> Totals	Invoice 1	\$38.46
		Transactions	

Department **07 - Engineering**

Program **070000 - Main**

Account **52110 - Office Supplies**

6530 - Office Depot, INC	07-Label tape, Mila Folders	03/03/2023	17.89
--------------------------	-----------------------------	------------	-------





# Board of Public Works Claim Register

Invoice Date Range 02/18/23 - 03/03/23

5103 - Staples Contract & Commercial, INC	07-Hanging Folders, Sharpie, Note pads	03/03/2023	66.31
	Account <b>52110 - Office Supplies</b> Totals	Invoice 2	<u>\$84.20</u>
Account <b>52420 - Other Supplies</b>		Transactions	
6530 - Office Depot, INC	07-Dymo Label Writer 550, Address Labels	03/03/2023	59.18
53442 - Paragon Micro, INC	07-Dell Monitor_2nd monitor for administrative assistant	03/03/2023	237.99
	Account <b>52420 - Other Supplies</b> Totals	Invoice 2	<u>\$297.17</u>
Account <b>53910 - Dues and Subscriptions</b>		Transactions	
2871 - International Municipal Signal Association (IMSA)	07-2023 Membership Dues_IMSA ID 50947-Enq Employees	03/03/2023	340.00
	Account <b>53910 - Dues and Subscriptions</b> Totals	Invoice 1	<u>\$340.00</u>
Account <b>54310 - Improvements Other Than Building</b>		Transactions	
204 - State Of Indiana	07-Crosswalks Ph1 (Change order 2)	03/03/2023	5,747.50
	Account <b>54310 - Improvements Other Than Building</b> Totals	Invoice 1	<u>\$5,747.50</u>
		Transactions	
	Program <b>070000 - Main</b> Totals	Invoice 6	<u>\$6,468.87</u>
		Transactions	
	Department <b>07 - Engineering</b> Totals	Invoice 6	<u>\$6,468.87</u>
		Transactions	
Department <b>09 - CFRD</b>			
Program <b>090000 - Main</b>			
Account <b>52110 - Office Supplies</b>			
6530 - Office Depot, INC	09-Office Supplies-Chlorox Wipes, Tissues, Hooks	03/03/2023	69.52
6530 - Office Depot, INC	09-lint rollers	03/03/2023	36.29
6530 - Office Depot, INC	09-Banquet Roll for Programs & Events	03/03/2023	92.07
	Account <b>52110 - Office Supplies</b> Totals	Invoice 3	<u>\$197.88</u>
Account <b>53160 - Instruction</b>		Transactions	



# Board of Public Works Claim Register

Invoice Date Range 02/18/23 - 03/03/23

6042 - International Town & Gown Association

09-ITGA 2023 Conference Registration for Beverly C-A	03/03/2023	595.00
Account <b>53160 - Instruction</b> Totals	Invoice 1	<u>\$595.00</u>
	Transactions	

Account **53960 - Grants**

5665 - Backline (All Options Pregnancy)

09-Reproductive Healthcare Emergency Grant 2022	03/03/2023	15,000.00
Account <b>53960 - Grants</b> Totals	Invoice 1	<u>\$15,000.00</u>
	Transactions	
Program <b>090000 - Main</b> Totals	Invoice 5	<u>\$15,792.88</u>
	Transactions	
Department <b>09 - CFRD</b> Totals	Invoice 5	<u>\$15,792.88</u>
	Transactions	

Department **10 - Legal**

Program **100000 - Main**

Account **52110 - Office Supplies**

8541 - Amazon.com Sales, INC (Amazon.com Services LLC)

10-surge protector requisition # 224156	03/03/2023	14.99
Account <b>52110 - Office Supplies</b> Totals	Invoice 1	<u>\$14.99</u>
	Transactions	

Account **53120 - Special Legal Services**

19660 - Bose McKinney & Evans, LLP

10-legal services annexation remonstrances-Jan 2023	03/03/2023	21,888.00
Account <b>53120 - Special Legal Services</b> Totals	Invoice 1	<u>\$21,888.00</u>
	Transactions	

Account **53990 - Other Services and Charges**

53442 - Paragon Micro, INC

10-adobe acrobat pro 2020	03/03/2023	489.99
Account <b>53990 - Other Services and Charges</b> Totals	Invoice 1	<u>\$489.99</u>
	Transactions	
Program <b>100000 - Main</b> Totals	Invoice 3	<u>\$22,392.98</u>
	Transactions	
Department <b>10 - Legal</b> Totals	Invoice 3	<u>\$22,392.98</u>
	Transactions	

Department **11 - Mayor's Office**

Program **110000 - Main**



# Board of Public Works Claim Register

Invoice Date Range 02/18/23 - 03/03/23

**Account 52420 - Other Supplies**

8541 - Amazon.com Sales, INC (Amazon.com Services LLC)	11 -Tickets for events	03/03/2023	9.79
651 - Engraving & Stamp Center, INC	11 -Name plate for new CoS	03/03/2023	18.28
7149 - Namify, LLC	11 -name badges	03/03/2023	38.20
<b>Account 52420 - Other Supplies Totals</b>		Invoice 3	<u>\$66.27</u>
		Transactions	

**Account 53910 - Dues and Subscriptions**

53442 - Paragon Micro, INC	11-Power BI Pro	03/03/2023	9.16
53442 - Paragon Micro, INC	11 -Power BI Pro	03/03/2023	9.16
53442 - Paragon Micro, INC	11-Power BI Pro	03/03/2023	9.16
<b>Account 53910 - Dues and Subscriptions Totals</b>		Invoice 3	<u>\$27.48</u>
		Transactions	

**Account 53960 - Grants**

1051 - Bloomington Economic Development Corp	11 -BEDC Annual Meeting Sponsorship	03/03/2023	750.00
205 - City Of Bloomington	11 -2023 Women's History Month Luncheon sponsorship	03/03/2023	500.00
205 - City Of Bloomington	11-2023 BHM Gala extra seat-Goodman	03/03/2023	60.00
<b>Account 53960 - Grants Totals</b>		Invoice 3	<u>\$1,310.00</u>
		Transactions	
<b>Program 110000 - Main Totals</b>		Invoice 9	<u>\$1,403.75</u>
		Transactions	
<b>Department 11 - Mayor's Office Totals</b>		Invoice 9	<u>\$1,403.75</u>
		Transactions	

**Department 12 - Human Resources**

**Program 120000 - Main**

**Account 53320 - Advertising**

6891 - Gatehouse Media Indiana Holdings	12-HT Job Ads - January 2023	03/03/2023	1,680.12
<b>Account 53320 - Advertising Totals</b>		Invoice 1	<u>\$1,680.12</u>
		Transactions	



# Board of Public Works Claim Register

Invoice Date Range 02/18/23 - 03/03/23

**Account 53990 - Other Services and Charges**

19660 - Bose McKinney & Evans, LLP	12-Consultation Services Employment Law - January 2023	03/03/2023	545.50
6099 - Safe Hiring Solutions	12-out of state background check	03/03/2023	278.95
<b>Account 53990 - Other Services and Charges Totals</b>		Invoice 2	<u>\$824.45</u>
Program <b>120000 - Main Totals</b>		Transactions Invoice 3	<u>\$2,504.57</u>
Department <b>12 - Human Resources Totals</b>		Transactions Invoice 3	<u>\$2,504.57</u>
		Transactions	

**Department 13 - Planning**

**Program 130000 - Main**

**Account 42080 - F.H.W.A. Planning**

585 - Bloomington Public Transportation Corporation	13- FY 2023 UPWP Q2 - Foursquare Strategic Plan	03/03/2023	54,938.19
205 - City Of Bloomington	13- FY 2023 UPWP Q2 - Asset Management	03/03/2023	1,686.72
199 - Monroe County Government	13- FY 2023 UPWP Q2 Infrastructure Management Systems	03/03/2023	4,555.28
<b>Account 42080 - F.H.W.A. Planning Totals</b>		Invoice 3	<u>\$61,180.19</u>
		Transactions	

**Account 53320 - Advertising**

6891 - Gatehouse Media Indiana Holdings	13-BZA Legal Ad for Case #AA-51-22	03/03/2023	29.40
<b>Account 53320 - Advertising Totals</b>		Invoice 1	<u>\$29.40</u>
		Transactions	

**Account 53990 - Other Services and Charges**

12604 - Howard D Bruce (Tabor/Bruce Architecture & Design, INC)	13 - ADU Design Services	03/03/2023	3,327.00
6235 - Toole Design Group, LLC	13-Corridor Study-College Ave & Walnut St-11/26-12/31/22	03/03/2023	1,222.39
<b>Account 53990 - Other Services and Charges Totals</b>		Invoice 2	<u>\$4,549.39</u>
Program <b>130000 - Main Totals</b>		Transactions Invoice 6	<u>\$65,758.98</u>
Department <b>13 - Planning Totals</b>		Transactions Invoice 6	<u>\$65,758.98</u>
		Transactions	



# Board of Public Works Claim Register

Invoice Date Range 02/18/23 - 03/03/23

Department **19 - Facilities Maintenance**

Program **190000 - Main**

Account **52310 - Building Materials and Supplies**

409 - Black Lumber Co. INC	19 - 18V Hepa Vac		03/03/2023	189.97
177 - Indiana Oxygen Company, INC	19- Cylinder Rental, Torch Supplies		03/03/2023	45.88

Account <b>52310 - Building Materials and Supplies</b> Totals	Invoice 2	\$235.85
	Transactions	

Account **52430 - Uniforms and Tools**

19171 - Aramark Uniform & Career Apparel Group, INC	19- Work Uniforms for Facility Employees - 2/9/2023		03/03/2023	30.84
19171 - Aramark Uniform & Career Apparel Group, INC	19- Work Uniforms for Facility Employees - 2/16/23		03/03/2023	30.84

Account <b>52430 - Uniforms and Tools</b> Totals	Invoice 2	\$61.68
	Transactions	

Account **53610 - Building Repairs**

32 - Cassidy Electrical Contractors, INC	SA- Electrical Work at City Hall-installed floor box	BC 2022-090	03/03/2023	533.38
651 - Engraving & Stamp Center, INC	19-Name Plaques		03/03/2023	23.23
321 - Harrell Fish, INC (HFI)	19-SA Qrtly Planned Maintenance Feb 2023	BC 2022-115	03/03/2023	2,088.00
321 - Harrell Fish, INC (HFI)	19-SA Chiller Repair in Council Chambers	BC 2022-115	03/03/2023	210.00
7402 - Nature's Way, INC	19- Plant Maintenance @ City Hall - 2/1/2023	BC 222-118	03/03/2023	353.43
1420 - Richard Trinkle (Trinkle SnowPlowing LLC)	19-SA-Push Snow/Ice Melt-Eastside CH- 12.24,12.26, 1.25.23	BC 2022-104	03/03/2023	450.00

Account <b>53610 - Building Repairs</b> Totals	Invoice 6	\$3,658.04
	Transactions	

Program <b>190000 - Main</b> Totals	Invoice 10	\$3,955.57
	Transactions	

Department <b>19 - Facilities Maintenance</b> Totals	Invoice 10	\$3,955.57
	Transactions	

Fund <b>101 - General Fund (S0101)</b> Totals	Invoice 72	\$151,662.32
	Transactions	

Fund **103 - Restricted Donations(ord 05-17)**





# Board of Public Works Claim Register

Invoice Date Range 02/18/23 - 03/03/23

Department **06 - Controller's Office**

Program **400101 - Animal Medical Services**

Account **53130 - Medical**

54639 - Shake Veterinary Services, INC (Town & Country Vet	01-Veterinary Diagnostics & Surgeries & spay/neutor	03/03/2023	350.16
	Account <b>53130 - Medical</b> Totals	Invoice 1	<u>\$350.16</u>
	Program <b>400101 - Animal Medical Services</b> Totals	Transactions Invoice 1	<u>\$350.16</u>
	Department <b>06 - Controller's Office</b> Totals	Transactions Invoice 1	<u>\$350.16</u>
	Fund <b>103 - Restricted Donations(ord 05-17)</b> Totals	Transactions Invoice 1	<u>\$350.16</u>
		Transactions	

Fund **153 - LIT – Economic Development**

Department **19 - Facilities Maintenance**

Program **190000 - Main**

Account **53990 - Other Services and Charges**

421 - Centerstone Of Indiana, INC	04: Brighton Btown DPW labor funding- Jan 2023	BC 2022-057	03/03/2023	2,593.01
	Account <b>53990 - Other Services and Charges</b> Totals		Invoice 1	<u>\$2,593.01</u>
	Program <b>190000 - Main</b> Totals		Transactions Invoice 1	<u>\$2,593.01</u>
	Department <b>19 - Facilities Maintenance</b> Totals		Transactions Invoice 1	<u>\$2,593.01</u>
			Transactions	

Department **28 - ITS**

Program **280000 - Main**

Account **53980 - Community Access TV/Radio**

64 - Monroe County Public Library	28-Public Meeting (CATS)-Jan-March 2023	BC 2022-139	03/03/2023	115,091.25
	Account <b>53980 - Community Access TV/Radio</b> Totals		Invoice 1	<u>\$115,091.25</u>
	Program <b>280000 - Main</b> Totals		Transactions Invoice 1	<u>\$115,091.25</u>
			Transactions	



# Board of Public Works Claim Register

Invoice Date Range 02/18/23 - 03/03/23

Department <b>28 - ITS</b> Totals		Invoice 1	\$115,091.25
Fund <b>153 - LIT – Economic Development</b> Totals		Transactions	
		Invoice 2	\$117,684.26
		Transactions	
Fund <b>176 - ARPA Local Fiscal Recvry (S9512)</b>			
Department <b>04 - Economic &amp; Sustainable Dev</b>			
Program <b>G21005 - ARPA COVID Local Fiscal Recovery</b>			
Account <b>53170 - Mgt. Fee, Consultants, and Workshops</b>			
7509 - Axis Architecture + Interiors, LLC	15-Additional Services for the Trades	03/03/2023	8,450.00
	District Tech Center		
	Account <b>53170 - Mgt. Fee, Consultants, and Workshops</b> Totals	Invoice 1	\$8,450.00
		Transactions	
Account <b>53960 - Grants</b>			
8570 - Dave Debikey	04-BGHIP Rebate - Dave Debikey	03/03/2023	1,000.00
51483 - Downtown Bloomington, INC	04: Funds for Several Downtown pubic art installations	03/03/2023	110,000.00
7532 - Christina Elem	04-Consulting Services for public art - C.Elam	03/03/2023	60.00
8075 - IFF (IFF Real Estate Services LLC)	04-SEEL Program - Facility Energy Assessments	03/03/2023	697.50
203 - INDIANA UNIVERSITY	04-ARPA Grant for Arts Communication Platform - IU	03/03/2023	72,500.00
8528 - Caleb Olin Meredith Poer	04-BAC ARPA Emerging Artist Grant - Caleb Poer	03/03/2023	1,600.00
8536 - University Players IU Bloomington	04- BAC Emerging Artists Grant - University Players	03/03/2023	2,000.00
421 - Centerstone Of Indiana, INC	04: Brighton Btown DPW labor funding for BC 2022-057	03/03/2023	27,468.49
421 - Centerstone Of Indiana, INC	Dec 2022		
	04: Brighton Btown DPW labor funding- BC 2022-057	03/03/2023	26,139.53
	Jan 2023		
	Account <b>53960 - Grants</b> Totals	Invoice 9	\$241,465.52
		Transactions	
	Program <b>G21005 - ARPA COVID Local Fiscal Recovery</b> Totals	Invoice 10	\$249,915.52
		Transactions	
	Department <b>04 - Economic &amp; Sustainable Dev</b> Totals	Invoice 10	\$249,915.52
		Transactions	
Department <b>20 - Street</b>			



# Board of Public Works Claim Register

Invoice Date Range 02/18/23 - 03/03/23

Program **G21005 - ARPA COVID Local Fiscal Recovery**

Account **52420 - Other Supplies**

8541 - Amazon.com Sales, INC (Amazon.com Services LLC)	20-Arborist safety helmets for tree crew	03/03/2023	173.98
6262 - Koenig Equipment, INC	20-Supplies for tree crew (bar, chains,oil, pluas)	03/03/2023	51.84
	Account <b>52420 - Other Supplies</b> Totals	Invoice 2	<hr/> \$225.82
	Program <b>G21005 - ARPA COVID Local Fiscal Recovery</b> Totals	Transactions Invoice 2	<hr/> \$225.82
	Department <b>20 - Street</b> Totals	Transactions Invoice 2	<hr/> \$225.82
	Fund <b>176 - ARPA Local Fiscal Recvry (S9512)</b> Totals	Transactions Invoice 12	<hr/> \$250,141.34
		Transactions	

Fund **249 - Grants Non Approp**

Department **04 - Economic & Sustainable Dev**

Program **G22008 - 2021 to 2024 Brownfield**

Account **53990 - Other Services and Charges**

4571 - BCA Environmental Consultants, LLC	04-2021-2024 EPA Brownfield Grant-Program Management	03/03/2023	480.00
4571 - BCA Environmental Consultants, LLC	04-2021-2024 EPA Brownfield Grant-Eligib Determin & Site Access	03/03/2023	320.00
4571 - BCA Environmental Consultants, LLC	04-2021-2024 EPA Brownfield Grant-03/4-12/19/22	03/03/2023	1,744.00
4571 - BCA Environmental Consultants, LLC	04-2021-2024 EPA Brownfield Grant-PH II Hospital Parcel C&D	03/03/2023	5,001.63
	Account <b>53990 - Other Services and Charges</b> Totals	Invoice 4	<hr/> \$7,545.63
	Program <b>G22008 - 2021 to 2024 Brownfield</b> Totals	Transactions Invoice 4	<hr/> \$7,545.63
	Department <b>04 - Economic &amp; Sustainable Dev</b> Totals	Transactions Invoice 4	<hr/> \$7,545.63
	Fund <b>249 - Grants Non Approp</b> Totals	Transactions Invoice 4	<hr/> \$7,545.63
		Transactions	

Fund **312 - Community Services**

Department **09 - CFRD**



# Board of Public Works Claim Register

Invoice Date Range 02/18/23 - 03/03/23

**Program 090016 - Com Serv - Safe & Civil**

**Account 52420 - Other Supplies**

4549 - Kroger Limited Partnership I

09-Cookies for Black History Month Class Presentation	03/03/2023	9.98
Account <b>52420 - Other Supplies</b> Totals	Invoice 1	<u>\$9.98</u>

Program <b>090016 - Com Serv - Safe &amp; Civil</b> Totals	Transactions Invoice 1	<u>\$9.98</u>
--	------------------------	---------------

Department <b>09 - CFRD</b> Totals	Transactions Invoice 1	<u>\$9.98</u>
------------------------------------	------------------------	---------------

Fund <b>312 - Community Services</b> Totals	Transactions Invoice 1	<u>\$9.98</u>
	Transactions	

**Fund 401 - Non-Reverting Telecom (S1146)**

**Department 25 - Telecommunications**

**Program 256000 - Services**

**Account 53150 - Communications Contract**

4170 - Comcast Cable Communications, INC	25 - Comcast Internet - 401 N Morton-March 2023	02/22/2023	203.40
4170 - Comcast Cable Communications, INC	28 - 3550 N. Kinser Cascades Clubhouse-1/27-2/26/23	02/22/2023	120.35
4170 - Comcast Cable Communications, INC	28-3940 N Kinser Pike-business serv./equip chqs-2/21-3/20/23	02/22/2023	169.86
4170 - Comcast Cable Communications, INC	25 - Internet - 627 N Morton - 1/17-2/16/2023	02/23/2023	178.45
4170 - Comcast Cable Communications, INC	25 - Internet - 627 N Morton - 2/17-3/16/2023	02/23/2023	178.45
4170 - Comcast Cable Communications, INC	25 - Internet - 627 N Morton - 12/17/2022-1/16/2023	02/23/2023	178.45

Account <b>53150 - Communications Contract</b> Totals	Invoice 6	<u>\$1,028.96</u>
---	-----------	-------------------

Program <b>256000 - Services</b> Totals	Transactions Invoice 6	<u>\$1,028.96</u>
---	------------------------	-------------------

Department <b>25 - Telecommunications</b> Totals	Transactions Invoice 6	<u>\$1,028.96</u>
--	------------------------	-------------------

Fund <b>401 - Non-Reverting Telecom (S1146)</b> Totals	Transactions Invoice 6	<u>\$1,028.96</u>
	Transactions	

**Fund 405 - Non-Reverting Improve I(S0113)**



# Board of Public Works Claim Register

Invoice Date Range 02/18/23 - 03/03/23

Department **06 - Controller's Office**

Program **060000 - Main**

Account **53120 - Special Legal Services**

19660 - Bose McKinney & Evans, LLP	10-legal srvs-alcoholic beverage permit Civic Center-Jan 2023	03/03/2023	196.00
19660 - Bose McKinney & Evans, LLP	10- legal services federally funded project- 2/6/23	03/03/2023	3,000.00
608 - Krieg Devault, LLP	10- legal services Governmental Affairs- January 2023	03/03/2023	2,500.00
Account <b>53120 - Special Legal Services</b> Totals			Invoice 3 Transactions
			<hr/> \$5,696.00
Program <b>060000 - Main</b> Totals			Invoice 3 Transactions
			<hr/> \$5,696.00
Department <b>06 - Controller's Office</b> Totals			Invoice 3 Transactions
			<hr/> \$5,696.00
Fund <b>405 - Non-Reverting Improve I(S0113)</b> Totals			Invoice 3 Transactions
			<hr/> \$5,696.00

Fund **450 - Local Road and Street(S0706)**

Department **20 - Street**

Program **200000 - Main**

Account **53520 - Street Lights / Traffic Signals**

223 - Duke Energy	02-Facilities Summary-FS#4 bill-11/29/22- 02/01/23	BC 2010-23	02/22/2023	593.89
223 - Duke Energy	02-14th & Walnut St 11/08/22-02/07/23		02/22/2023	164.25
223 - Duke Energy	02-Traffic Signal Summary electric bill- 12/30/22-02/02/23	BC 2018-0.	02/22/2023	3,905.68
223 - Duke Energy	02-Street Light Summary bill-12/10/22- 01/27/23	BC 20101-23	02/22/2023	42,484.26
Account <b>53520 - Street Lights / Traffic Signals</b> Totals			Invoice 4 Transactions	<hr/> \$47,148.08
Program <b>200000 - Main</b> Totals			Invoice 4 Transactions	<hr/> \$47,148.08
Department <b>20 - Street</b> Totals			Invoice 4 Transactions	<hr/> \$47,148.08
Fund <b>450 - Local Road and Street(S0706)</b> Totals			Invoice 4 Transactions	<hr/> \$47,148.08





# Board of Public Works Claim Register

Invoice Date Range 02/18/23 - 03/03/23

**Fund 451 - Motor Vehicle Highway(S0708)**

Department **20 - Street**

Program **200000 - Main**

**Account 52210 - Institutional Supplies**

313 - Fastenal Company	20-Safety Supplies for Crews (gloves, glasses, ear plugs)	03/03/2023	230.10
<b>Account 52210 - Institutional Supplies Totals</b>		Invoice 1	\$230.10
		Transactions	

**Account 52340 - Other Repairs and Maintenance**

480 - Proveli, LLC ( Hall Signs, INC)	20-Sign materials for Welcome to Bloomington	03/03/2023	1,703.90
337 - Stansifer Radio Co, INC	20-Parts for signal repair at 17 & Dunn	03/03/2023	13.78
3039 - Unistructural Support Systems, LTD	20-Sign materials (Poles & Anchors)	03/03/2023	7,170.00
<b>Account 52340 - Other Repairs and Maintenance Totals</b>		Invoice 3	\$8,887.68
		Transactions	

**Account 52420 - Other Supplies**

8541 - Amazon.com Sales, INC (Amazon.com Services LLC)	20-Retevis RT68 Walkie Talkies for crews	03/03/2023	118.99
409 - Black Lumber Co. INC	20-Bollards-Eagleson-lumber for concrete forms	03/03/2023	113.31
409 - Black Lumber Co. INC	20-Bollards-Eagleson-hardware	03/03/2023	3.28
409 - Black Lumber Co. INC	20-Winslow/Henderson-band saw blade	03/03/2023	27.99
409 - Black Lumber Co. INC	20-lumber-damaged mailboxes	03/03/2023	10.89
409 - Black Lumber Co. INC	20-lumber-damaged mailboxes	03/03/2023	10.89
409 - Black Lumber Co. INC	20-scraper to clean corners of hot boxes	03/03/2023	69.98
409 - Black Lumber Co. INC	20-2203 S. Rockport-mailbox damage-retro fit ez base	03/03/2023	29.99
409 - Black Lumber Co. INC	20-Pete Ellis Dr-guardrail hardware	03/03/2023	25.92
908 - JB Salvage (Westside Auto Parts)	20-Used steel for ballards on State Ct & stock	03/03/2023	9.00



# Board of Public Works Claim Register

Invoice Date Range 02/18/23 - 03/03/23

4574 - John Deere Financial f.s.b. (Rural King)	20-60V Grinder & 20pc ratcheting wrench set	03/03/2023	428.98
394 - Kleindorfer Hardware & Variety	20-truck cleaning supplies	03/03/2023	15.38
394 - Kleindorfer Hardware & Variety	20-shackles	03/03/2023	9.38
394 - Kleindorfer Hardware & Variety	20-chain-parts for sign puller	03/03/2023	6.46
Account <b>52420 - Other Supplies</b> Totals		Invoice 14 Transactions	<hr/> \$880.44
<b>Account 53130 - Medical</b>			
231 - IU Health OCC Health Services	20-M Heagy-DS DOT 5 Panel Screen-1/19/23	03/03/2023	50.00
231 - IU Health OCC Health Services	20-D. Akers-DS DOT 5 Panel Screen-1/25/23	03/03/2023	50.00
231 - IU Health OCC Health Services	20-T. Carroll-DS DOT 5 Panel Screen-2/02/23	03/03/2023	50.00
231 - IU Health OCC Health Services	20-R. Hitchcox-DS DOT 5 Panel Screen-2/02/23	03/03/2023	50.00
231 - IU Health OCC Health Services	20-C. Phipps-DS DOT 5 Panel Screen-02/02/23	03/03/2023	50.00
Account <b>53130 - Medical</b> Totals		Invoice 5 Transactions	<hr/> \$250.00
<b>Account 53150 - Communications Contract</b>			
5465 - Emergency Radio Service LLC (ERS-OCI Wireless)	20-Monthly Two-way Radio Services for Vehicles-Feb 2023	03/03/2023	2,321.25
Account <b>53150 - Communications Contract</b> Totals		Invoice 1 Transactions	<hr/> \$2,321.25
<b>Account 53530 - Water and Sewer</b>			
208 - City Of Bloomington Utilities	20-Street Dept-fire hydrant-water/sewer bill-January 2023	02/22/2023	44.47
208 - City Of Bloomington Utilities	20-Street Dept-water/sewer bill-January 2023	02/22/2023	293.69
Account <b>53530 - Water and Sewer</b> Totals		Invoice 2 Transactions	<hr/> \$338.16
<b>Account 53540 - Natural Gas</b>			
222 - Indiana Gas Co. INC (CenterPoint Energy) (Vectren)	20-Street Dept-gas bill 01/05-02/06/23	02/22/2023	262.30
Account <b>53540 - Natural Gas</b> Totals		Invoice 1 Transactions	<hr/> \$262.30



# Board of Public Works Claim Register

Invoice Date Range 02/18/23 - 03/03/23

**Account 53730 - Machinery and Equipment Rental**

6928 - Lavin Rental, LLC (Master Rental)	20-Rental of two man auger/install sign @ Hend/Atwater	03/03/2023	62.70
<b>Account 53730 - Machinery and Equipment Rental Totals</b>		Invoice 1	\$62.70
		Transactions	

**Account 53920 - Laundry and Other Sanitation Services**

19171 - Aramark Uniform & Career Apparel Group, INC	20-mat/towel service-2/8/23	03/03/2023	34.28
19171 - Aramark Uniform & Career Apparel Group, INC	20-uniform rental (minus payroll ded)- 2/8/23	03/03/2023	8.72
19171 - Aramark Uniform & Career Apparel Group, INC	20-uniform rental (minus payroll ded)- 1/25/23	03/03/2023	6.83
19171 - Aramark Uniform & Career Apparel Group, INC	20-uniform rental (minus payroll ded)- 2/1/23	03/03/2023	8.72
19171 - Aramark Uniform & Career Apparel Group, INC	20-uniform rental (minus payroll ded)- 12/14/22	03/03/2023	9.77
19171 - Aramark Uniform & Career Apparel Group, INC	20-mat/towel service-12/14/22	03/03/2023	34.28
19171 - Aramark Uniform & Career Apparel Group, INC	20-uniform rental (minus payroll ded)- 12/21/22	03/03/2023	7.88
19171 - Aramark Uniform & Career Apparel Group, INC	20-mat/towel service-12/21/22	03/03/2023	34.28
19171 - Aramark Uniform & Career Apparel Group, INC	20-uniform rental (minus payroll ded)- 12/28/22	03/03/2023	8.72
19171 - Aramark Uniform & Career Apparel Group, INC	20-uniform rental (minus payroll ded)- 1/4/23	03/03/2023	8.72
19171 - Aramark Uniform & Career Apparel Group, INC	20-uniform rental (minus payroll ded)- 1/11/23	03/03/2023	8.72
19171 - Aramark Uniform & Career Apparel Group, INC	20-uniform rental (minus payroll ded)- 1/18/23	03/03/2023	8.72
<b>Account 53920 - Laundry and Other Sanitation Services Totals</b>		Invoice 12	\$179.64
		Transactions	

**Account 53990 - Other Services and Charges**

902 - Indiana Underground Plant Protection Service, INC	20-Line Locate Services for 2023 January	03/03/2023	546.25
19444 - Jeffery D Todd (Todd Septic Tank Service)	20-pump saltwater collection tanks- 1/9/2023	03/03/2023	200.00
<b>Account 53990 - Other Services and Charges Totals</b>		Invoice 2	\$746.25
		Transactions	
<b>Program 200000 - Main Totals</b>		Invoice 42	\$14,158.52
		Transactions	



# Board of Public Works Claim Register

Invoice Date Range 02/18/23 - 03/03/23

Department <b>20 - Street</b> Totals		Invoice 42	\$14,158.52
		Transactions	
Fund <b>451 - Motor Vehicle Highway(S0708)</b> Totals		Invoice 42	\$14,158.52
		Transactions	
Fund <b>452 - Parking Facilities(S9502)</b>			
Department <b>26 - Parking</b>			
Program <b>260000 - Main</b>			
Account <b>52210 - Institutional Supplies</b>			
4394 - Richardson Enterprises of Blgtn,LLC (FastSigns)	26-Windmaster Signs	03/03/2023	375.55
4394 - Richardson Enterprises of Blgtn,LLC (FastSigns)	26-Windmaster Signs	03/03/2023	425.55
Account <b>52210 - Institutional Supplies</b> Totals		Invoice 2	\$801.10
		Transactions	
Account <b>52340 - Other Repairs and Maintenance</b>			
293 - J&S Locksmith Shop, INC	26-Changing out Lock Cylinder	03/03/2023	105.80
Account <b>52340 - Other Repairs and Maintenance</b> Totals		Invoice 1	\$105.80
		Transactions	
Account <b>53530 - Water and Sewer</b>			
208 - City Of Bloomington Utilities	26-Morton St Garage-water/sewer bill- January 2023	02/22/2023	57.36
Account <b>53530 - Water and Sewer</b> Totals		Invoice 1	\$57.36
		Transactions	
Account <b>53610 - Building Repairs</b>			
392 - Koorsen Fire & Security, INC	26-SA Morton Street Garage Alarm Monitoring-2/1-4/30/23	BC 2022-092 03/03/2023	150.00
392 - Koorsen Fire & Security, INC	26-SA 4th St Garage Garage Service Monitoring-2/1-4/30/23	BC 2022-092 03/03/2023	120.00
392 - Koorsen Fire & Security, INC	26-SA Trades District Garage Service Monitoring	BC 2022-092 03/03/2023	600.00
1537 - Indiana Door & Hardware Specialties, INC	26- SA- Morton St Parking Doors service call	BC 2022-117 03/03/2023	758.00
393 - Kone INC	26-SA -Morton Street - furnish and install a new ADA telephone	BC 2023-004 03/03/2023	1,656.00
1420 - Richard Trinkle (Trinkle SnowPlowing LLC)	26-SA -Snow Removal at Garages (Trades and 4th St) - 1/25/2023	BC 2022-104 03/03/2023	300.00



# Board of Public Works Claim Register

Invoice Date Range 02/18/23 - 03/03/23

1420 - Richard Trinkle (Trinkle SnowPlowing LLC)	26-Snow Removal&Icemelt /Lot 1 & 3; Lincoln St 12/24 & 12/26/22	BC 2022-104	03/03/2023	1,530.00
	Account <b>53610 - Building Repairs</b> Totals		Invoice 7	<hr/> \$5,114.00
			Transactions	
Account <b>53650 - Other Repairs</b>				
3397 - Evens Time, INC	26-Morton St Garage-ticket splitter- 1/17/23-beyond SA		03/03/2023	492.99
	Account <b>53650 - Other Repairs</b> Totals		Invoice 1	<hr/> \$492.99
			Transactions	
	Program <b>260000 - Main</b> Totals		Invoice 12	<hr/> \$6,571.25
			Transactions	
	Department <b>26 - Parking</b> Totals		Invoice 12	<hr/> \$6,571.25
			Transactions	
	Fund <b>452 - Parking Facilities(S9502)</b> Totals		Invoice 12	<hr/> \$6,571.25
			Transactions	
Fund <b>454 - Alternative Transport(S6301)</b>				
Department <b>05 - Common Council</b>				
Program <b>050000 - Main</b>				
Account <b>54310 - Improvements Other Than Building</b>				
17 - Bynum Fanyo & Associates, INC	07-Adams St ROW-11/6/22-1/31/23	BC 2022-051	03/03/2023	58,025.00
	Account <b>54310 - Improvements Other Than Building</b> Totals		Invoice 1	<hr/> \$58,025.00
			Transactions	
	Program <b>050000 - Main</b> Totals		Invoice 1	<hr/> \$58,025.00
			Transactions	
	Department <b>05 - Common Council</b> Totals		Invoice 1	<hr/> \$58,025.00
			Transactions	
	Fund <b>454 - Alternative Transport(S6301)</b> Totals		Invoice 1	<hr/> \$58,025.00
			Transactions	
Fund <b>455 - Parking Meter Fund(S2141)</b>				
Department <b>26 - Parking</b>				
Program <b>260000 - Main</b>				
Account <b>52340 - Other Repairs and Maintenance</b>				
313 - Fastenal Company	26-plastic wireties for event parking		03/03/2023	118.73





# Board of Public Works Claim Register

Invoice Date Range 02/18/23 - 03/03/23

4264 - IPS Group, INC	26-card readers for the kiosk in the surface lots	03/03/2023	2,040.19
4264 - IPS Group, INC	26-batteries for meters, card readers for meters	03/03/2023	5,450.00
4264 - IPS Group, INC	26-service cards to collect, maintain parking meters	03/03/2023	165.00
<b>Account 52340 - Other Repairs and Maintenance Totals</b>		Invoice 4 Transactions	<u>\$7,773.92</u>
<b>Account 53150 - Communications Contract</b>			
4264 - IPS Group, INC	26-bank fees and communications fees January 2023	03/03/2023	9,131.25
<b>Account 53150 - Communications Contract Totals</b>		Invoice 1 Transactions	<u>\$9,131.25</u>
<b>Account 53240 - Freight / Other</b>			
4264 - IPS Group, INC	26-batteries for meters, card readers for meters	03/03/2023	21.08
4264 - IPS Group, INC	26-service cards to collect, maintain parking meters	03/03/2023	21.08
<b>Account 53240 - Freight / Other Totals</b>		Invoice 2 Transactions	<u>\$42.16</u>
<b>Account 53830 - Bank Charges</b>			
4264 - IPS Group, INC	26-bank fees and communications fees January 2023	03/03/2023	4,073.29
<b>Account 53830 - Bank Charges Totals</b>		Invoice 1 Transactions	<u>\$4,073.29</u>
<b>Account 53990 - Other Services and Charges</b>			
480 - Proveli, LLC ( Hall Signs, INC)	26-sign for history center	03/03/2023	71.27
4394 - Richardson Enterprises of Blgtn,LLC (FastSigns)	26-sign removal for 900 E. Atwater st - parkmobile signs	03/03/2023	153.33
1420 - Richard Trinkle (Trinkle SnowPlowing LLC)	26-Snow Removal&Icemelt /Lot 1 & 3; Lincoln St 12/24 & 12/26/22	BC 2022-104 03/03/2023	1,560.00
<b>Account 53990 - Other Services and Charges Totals</b>		Invoice 3 Transactions	<u>\$1,784.60</u>
<b>Program 260000 - Main Totals</b>		Invoice 11 Transactions	<u>\$22,805.22</u>
<b>Department 26 - Parking Totals</b>		Invoice 11 Transactions	<u>\$22,805.22</u>
<b>Fund 455 - Parking Meter Fund(S2141) Totals</b>		Invoice 11 Transactions	<u>\$22,805.22</u>



# Board of Public Works Claim Register

Invoice Date Range 02/18/23 - 03/03/23

**Fund 456 - MVH Restricted**

Department **20 - Street**

Program **200000 - Main**

Account **53990 - Other Services and Charges**

7905 - IMS Infrastructure Management Services, LLC

20-Asset management data collection services-12/18/22	BC 2021-81	03/03/2023	3,088.70
Account <b>53990 - Other Services and Charges</b> Totals		Invoice 1	<u>\$3,088.70</u>
		Transactions	
Program <b>200000 - Main</b> Totals		Invoice 1	<u>\$3,088.70</u>
		Transactions	
Department <b>20 - Street</b> Totals		Invoice 1	<u>\$3,088.70</u>
		Transactions	
Fund <b>456 - MVH Restricted</b> Totals		Invoice 1	<u>\$3,088.70</u>
		Transactions	

**Fund 601 - Cumulative Capital Devlp(S2391)**

Department **02 - Public Works**

Program **020000 - Main**

Account **52330 - Street , Alley, and Sewer Material**

351 - Young Trucking, INC

20-Clear Lane De-icing Salt-1/24-1/27/23		03/03/2023	92,473.50
Account <b>52330 - Street , Alley, and Sewer Material</b> Totals		Invoice 1	<u>\$92,473.50</u>
		Transactions	

Account **52420 - Other Supplies**

4186 - Carrier & Gable, INC

10412 - Complete Masonry Supplies, INC

8527 - National Tank Outlet

603 - Traffic Control Corporation

20-APS Pushbutton Assy for College Mall & Buick Cad		03/03/2023	832.00
20-Concrete blankets for sidewalk projects		03/03/2023	394.80
20-4200 gallon verticle tank for salt brine		03/03/2023	6,257.34
20-AI Preempt/Priority FMUS2 Cat (2nd, 3rd,College Mall )		03/03/2023	48,367.00
Account <b>52420 - Other Supplies</b> Totals		Invoice 4	<u>\$55,851.14</u>
		Transactions	
Program <b>020000 - Main</b> Totals		Invoice 5	<u>\$148,324.64</u>
		Transactions	



# Board of Public Works Claim Register

Invoice Date Range 02/18/23 - 03/03/23

Department <b>02 - Public Works</b> Totals		Invoice 5	\$148,324.64
Fund <b>601 - Cumulative Capital Devlp(S2391)</b> Totals		Transactions	
		Invoice 5	\$148,324.64
		Transactions	
Fund <b>730 - Solid Waste (S6401)</b>			
Department <b>16 - Sanitation</b>			
Program <b>160000 - Main</b>			
Account <b>52420 - Other Supplies</b>			
8541 - Amazon.com Sales, INC (Amazon.com Services LLC)	16-Control tubes of cockroach bait	03/03/2023	36.49
4574 - John Deere Financial f.s.b. (Rural King)	16-batteries,paper towels, microfiber cloths,(2)sprayers	03/03/2023	62.95
394 - Kleindorfer Hardware & Variety	16-5 coat hooks for garage	03/03/2023	6.45
394 - Kleindorfer Hardware & Variety	16-hose & parts for power washer	03/03/2023	39.96
Account <b>52420 - Other Supplies</b> Totals		Invoice 4	\$145.85
		Transactions	
Account <b>53150 - Communications Contract</b>			
5465 - Emergency Radio Service LLC (ERS-OCI Wireless)	16-Wirless Radios Services for Feb 1-28, 2023	03/03/2023	572.05
Account <b>53150 - Communications Contract</b> Totals		Invoice 1	\$572.05
		Transactions	
Account <b>53210 - Telephone</b>			
7146 - Routeware, INC	16-BiAnnual Cellular Chgs-Sanitation Trucks-1/1-6/30/23/	03/03/2023	2,160.00
Account <b>53210 - Telephone</b> Totals		Invoice 1	\$2,160.00
		Transactions	
Account <b>53410 - Liability / Casualty Premiums</b>			
622 - Truck Country of Indiana, INC (Stoops Freightliner)	16-repairs to Truck 939-replace grille, mirror, antenna	03/03/2023	6,105.60
Account <b>53410 - Liability / Casualty Premiums</b> Totals		Invoice 1	\$6,105.60
		Transactions	
Account <b>53640 - Hardware and Software Maintenance</b>			
7146 - Routeware, INC	17 Tablet Hardware Replacement 12 Sanitation Trucks	03/03/2023	3,308.00



# Board of Public Works Claim Register

Invoice Date Range 02/18/23 - 03/03/23

Account <b>53640 - Hardware and Software Maintenance</b> Totals		Invoice 1	\$3,308.00
Account <b>53920 - Laundry and Other Sanitation Services</b>		Transactions	
19171 - Aramark Uniform & Career Apparel Group, INC	16-Laundry Services - 2-8-2023	03/03/2023	4.62
19171 - Aramark Uniform & Career Apparel Group, INC	16-Mat Services - 02/08/2023	03/03/2023	23.26
Account <b>53920 - Laundry and Other Sanitation Services</b> Totals		Invoice 2	\$27.88
Program <b>160000 - Main</b> Totals		Transactions	
Department <b>16 - Sanitation</b> Totals		Invoice 10	\$12,319.38
Fund <b>730 - Solid Waste (S6401)</b> Totals		Transactions	
		Invoice 10	\$12,319.38
		Transactions	
		Invoice 10	\$12,319.38
		Transactions	
Fund <b>800 - Risk Management(S0203)</b>			
Department <b>10 - Legal</b>			
Program <b>100000 - Main</b>			
Account <b>52430 - Uniforms and Tools</b>			
8613 - Crane's Leather & Shoe Shop, INC	10-safety shoes- L. Hardin 11 D-2/2/23	03/03/2023	100.00
8613 - Crane's Leather & Shoe Shop, INC	10-safety shoes- R. Kinser (12M)-2/11/23	03/03/2023	100.00
1448 - Shoe Carnival, INC	10-safety shoes- Kerr 10.5-8/31/22	03/03/2023	89.98
Account <b>52430 - Uniforms and Tools</b> Totals		Invoice 3	\$289.98
Account <b>53130 - Medical</b>		Transactions	
6854 - Andrew J Boden	10-reimb for CDL physical-2/7/23	03/03/2023	100.00
7562 - Brown, Tammy S	10-reimb for CDL physical-2/3/23	03/03/2023	97.00
8574 - Stephen Micheal French	10-reimb for CDL physical-1/31/23	03/03/2023	100.00
8104 - Timothy Lee Jacobs	10-reimb for CDL physical-2/9/23	03/03/2023	100.00
6287 - Joseph E Morrow	10-reimb for CDL physical-1/16/23	03/03/2023	100.00



# Board of Public Works Claim Register

Invoice Date Range 02/18/23 - 03/03/23

		Invoice 5	\$497.00
Account <b>53130 - Medical</b> Totals		Transactions	
Program <b>100000 - Main</b> Totals		Invoice 8	\$786.98
Department <b>10 - Legal</b> Totals		Transactions	
Fund <b>800 - Risk Management(S0203)</b> Totals		Invoice 8	\$786.98
		Transactions	
Fund <b>801 - Health Insurance Trust</b>			
Department <b>12 - Human Resources</b>			
Program <b>120000 - Main</b>			
Account <b>53990 - Other Services and Charges</b>			
17785 - The Howard E. Nyhart Company, INC	12 - Nyhart Admin Fee (FSA, HSA, Wellness) - January 2023	03/03/2023	1,253.40
17785 - The Howard E. Nyhart Company, INC	12 - Nyhart Admin Fee (FSA, HSA, Wellness) - December 2022	03/03/2023	1,235.50
Account <b>53990 - Other Services and Charges</b> Totals		Invoice 2	\$2,488.90
Program <b>120000 - Main</b> Totals		Transactions	
Department <b>12 - Human Resources</b> Totals		Invoice 2	\$2,488.90
Fund <b>801 - Health Insurance Trust</b> Totals		Transactions	
		Invoice 2	\$2,488.90
		Transactions	
Fund <b>802 - Fleet Maintenance(S9500)</b>			
Department <b>17 - Fleet Maintenance</b>			
Program <b>170000 - Main</b>			
Account <b>52110 - Office Supplies</b>			
6530 - Office Depot, INC	17 - office supplies -packing tape, rubber bands	03/03/2023	31.66
6530 - Office Depot, INC	17 - office supplies-oil base paint marker	03/03/2023	46.99
Account <b>52110 - Office Supplies</b> Totals		Invoice 2	\$78.65
		Transactions	
Account <b>52230 - Garage and Motor Supplies</b>			





# Board of Public Works Claim Register

Invoice Date Range 02/18/23 - 03/03/23

50605 - Bauer Built, INC	17 - tires for stock		03/03/2023	2,602.86
50605 - Bauer Built, INC	17- (4) 12R225 H XDN2 tires		03/03/2023	2,752.00
50605 - Bauer Built, INC	17 - tires for stock		03/03/2023	4,404.20
4693 - Monroe County Tire & Supply, INC	17 - tires and tire supplies		03/03/2023	687.32
4693 - Monroe County Tire & Supply, INC	17 - tires and tire supplies		03/03/2023	1,336.40
Account <b>52230 - Garage and Motor Supplies</b> Totals			Invoice 5 Transactions	<u>\$11,782.78</u>
Account <b>52240 - Fuel and Oil</b>				
7854 - Premier AG CO-OP, INC (Premier Energy)	17 - diesel fuel (7,363 gallons)-2/8/23	BC 2022-109 D	03/03/2023	27,528.05
Account <b>52240 - Fuel and Oil</b> Totals			Invoice 1 Transactions	<u>\$27,528.05</u>
Account <b>52320 - Motor Vehicle Repair</b>				
244 - Bloomington Ford, INC	17 -(2) relay		03/03/2023	27.50
244 - Bloomington Ford, INC	17 - 199H OSLSS PM service		03/03/2023	25.17
244 - Bloomington Ford, INC	17 - #207 OSLSS PM services		03/03/2023	27.57
244 - Bloomington Ford, INC	17 - credit for bill wrong amount for Oil.		03/03/2023	(55.76)
244 - Bloomington Ford, INC	Motorcraft SAE OW 17 - @217 OSLSS pm service		03/03/2023	32.33
244 - Bloomington Ford, INC	17 - RTDKey Key		03/03/2023	65.00
244 - Bloomington Ford, INC	17 - @1215 OSL check engine light		03/03/2023	81.33
244 - Bloomington Ford, INC	17 - ford catalytic converter		03/03/2023	500.00
244 - Bloomington Ford, INC	17 - Seal		03/03/2023	567.25
244 - Bloomington Ford, INC	17- #806 OSLSS pm service and other repairs		03/03/2023	287.22
941 - Central Indiana Truck Equipment Corporation	17 - 1" check valves (2)		03/03/2023	379.74
594 - Curry Auto Center, INC	17 - credit for valve returned from inv# 5105778		03/03/2023	(100.00)



# Board of Public Works Claim Register

Invoice Date Range 02/18/23 - 03/03/23

594 - Curry Auto Center, INC	17 - #575 OSL sheet metal repair	03/03/2023	683.85
594 - Curry Auto Center, INC	17 - #875 OSL check engine light	03/03/2023	545.04
455 - Industrial Service & Supply, INC	17 - adapter union	03/03/2023	4.41
455 - Industrial Service & Supply, INC	17 - Hyd Adapter	03/03/2023	7.72
796 - Interstate Battery System of Bloomington, INC	17 - 2 SRM-24 batteries for City vehicles	03/03/2023	191.26
796 - Interstate Battery System of Bloomington, INC	17 - various batteries for City vehicles	03/03/2023	528.53
4693 - Monroe County Tire & Supply, INC	17- tires for #819 & stock	03/03/2023	311.90
53385 - O'Reilly Automotive Stores, INC	17 - various parts-manifold set	03/03/2023	10.61
53385 - O'Reilly Automotive Stores, INC	17 - spark plug & cop boot	03/03/2023	56.28
53385 - O'Reilly Automotive Stores, INC	17 - credit for returned parts-cop coil, micro-v belt	03/03/2023	(99.95)
53385 - O'Reilly Automotive Stores, INC	17 - new CV shaft	03/03/2023	106.29
53385 - O'Reilly Automotive Stores, INC	17 - 14.1 OZ Grease & Freight	03/03/2023	158.54
53385 - O'Reilly Automotive Stores, INC	17 - hub assembly	03/03/2023	275.50
53385 - O'Reilly Automotive Stores, INC	17-Brake Rotor (2) & OEx Brk Pads (2)	03/03/2023	450.16
476 - Southern Indiana Parts, INC (Napa Auto Parts)	17 - various parts and shop supplies for January	03/03/2023	7,614.98
337 - Stansifer Radio Co, INC	17-R5511D20-12F NTE	03/03/2023	91.88
582 - Town & Country Chrysler Dodge Jeep, INC	17-latch hot and cable hood latch	03/03/2023	223.00
582 - Town & Country Chrysler Dodge Jeep, INC	17-Seal Slim Line	03/03/2023	123.30
582 - Town & Country Chrysler Dodge Jeep, INC	17- work preformed at chrysler - 2019 Dodge Charger	03/03/2023	974.68
622 - Truck Country of Indiana, INC (Stoops Freightliner)	17-Isolator-radiator, nut-hex, washer-harden	03/03/2023	64.94
622 - Truck Country of Indiana, INC (Stoops Freightliner)	17-Pin-Radiator, retainer clip	03/03/2023	76.52
622 - Truck Country of Indiana, INC (Stoops Freightliner)	17-Tube, hose core/tank	03/03/2023	126.62



# Board of Public Works Claim Register

Invoice Date Range 02/18/23 - 03/03/23

622 - Truck Country of Indiana, INC (Stoops Freightliner	17-Hoses	03/03/2023	157.27
622 - Truck Country of Indiana, INC (Stoops Freightliner	17-tube assy, core/take and hose	03/03/2023	3,431.78
8183 - XL Parts LLC (XL Parts/Dealer Service Warehouse)	17-Cabin Filter	03/03/2023	24.20
8183 - XL Parts LLC (XL Parts/Dealer Service Warehouse)	17-Cabin Filter	03/03/2023	72.60
8183 - XL Parts LLC (XL Parts/Dealer Service Warehouse)	17-Coil Asy, sparkplug	03/03/2023	539.68
8183 - XL Parts LLC (XL Parts/Dealer Service Warehouse)	17-brake kit, brake pad, oil filter, titanium brake rotor	03/03/2023	777.46
<b>Account 52320 - Motor Vehicle Repair Totals</b>		Invoice 40	<u>\$19,366.40</u>
		Transactions	

**Account 52420 - Other Supplies**

409 - Black Lumber Co. INC	17 - 2x6 10 Construction lumber for shop	03/03/2023	9.49
4918 - HELM, INC	17 - Ford IDS software-1 year-expires 2/3/24	03/03/2023	800.00
177 - Indiana Oxygen Company, INC	17 - Propane refill in cylinder	03/03/2023	252.45
177 - Indiana Oxygen Company, INC	17 - gases for torch and welding equipment	03/03/2023	252.85
177 - Indiana Oxygen Company, INC	17 - gases for torch and welding equipment	03/03/2023	289.23
394 - Kleindorfer Hardware & Variety	17 - misc hardware	03/03/2023	4.80
394 - Kleindorfer Hardware & Variety	17 - misc hardware	03/03/2023	22.08
394 - Kleindorfer Hardware & Variety	17 - misc hardware-broom, light bulbs, spray paint	03/03/2023	171.65
394 - Kleindorfer Hardware & Variety	17 - misc hardware	03/03/2023	70.59
8181 - Lawson Products, INC	17 - shop supplies and DNI parts	03/03/2023	1,346.89
6216 - Terminal Supply, INC	17 - shop supplies drill bits, fuses, battery terminals and etc	03/03/2023	51.69
6216 - Terminal Supply, INC	17 - shop supplies drill bits, fuses, battery terminals and etc	03/03/2023	128.59
<b>Account 52420 - Other Supplies Totals</b>		Invoice 12	<u>\$3,400.31</u>
		Transactions	

**Account 53130 - Medical**



# Board of Public Works Claim Register

Invoice Date Range 02/18/23 - 03/03/23

231 - IU Health OCC Health Services

17-J. Smith-DS DOT 5 Panel E Screen-1/13/23		03/03/2023	50.00
Account <b>53130 - Medical</b> Totals		Invoice 1 Transactions	<u>\$50.00</u>

**Account 53610 - Building Repairs**

321 - Harrell Fish, INC (HFI)

17- SA- Backflow Testing -1/30/23	BC 2022-116	03/03/2023	375.00
-----------------------------------	-------------	------------	--------

392 - Koorsen Fire & Security, INC

17-SA Quarterly Monitoring @ Fleet 2.1-4.30.23	BC 2022-092	03/03/2023	91.27
--	-------------	------------	-------

392 - Koorsen Fire & Security, INC

17-SA Fire Alarm System Installation Fleet	BC 2022-092	03/03/2023	5,161.78
--	-------------	------------	----------

Account <b>53610 - Building Repairs</b> Totals		Invoice 3 Transactions	<u>\$5,628.05</u>
--	--	------------------------	-------------------

**Account 53620 - Motor Repairs**

4336 - American Eagle Auto Glass of Terre Haute, INC

17 - #765 windshield replacement		03/03/2023	250.00
----------------------------------	--	------------	--------

244 - Bloomington Ford, INC

17 - 199H OSLSS PM service		03/03/2023	28.00
----------------------------	--	------------	-------

244 - Bloomington Ford, INC

17 - #207 OSLSS PM services		03/03/2023	28.00
-----------------------------	--	------------	-------

244 - Bloomington Ford, INC

17 - @217 OSLSS pm service		03/03/2023	28.00
----------------------------	--	------------	-------

244 - Bloomington Ford, INC

17 - @1215 OSL check engine light		03/03/2023	87.50
-----------------------------------	--	------------	-------

244 - Bloomington Ford, INC

17- #806 OSLSS pm service and other repairs		03/03/2023	810.24
---	--	------------	--------

594 - Curry Auto Center, INC

17 - #575 OSL sheet metal repair		03/03/2023	145.50
----------------------------------	--	------------	--------

594 - Curry Auto Center, INC

17 - #875 OSL check engine light		03/03/2023	1,314.95
----------------------------------	--	------------	----------

4474 - Ken's Westside Service & Towing, LLC

17 - tire service for Unit #134-2/4/23		03/03/2023	50.00
--	--	------------	-------

4474 - Ken's Westside Service & Towing, LLC

17 - tow Unit #829-2/16/23		03/03/2023	75.00
----------------------------	--	------------	-------

Account <b>53620 - Motor Repairs</b> Totals		Invoice 10 Transactions	<u>\$2,817.19</u>
---	--	-------------------------	-------------------

**Account 53650 - Other Repairs**

298 - Commercial Service Of Bloomington, INC

17 - air compressor repair-12/19/22		03/03/2023	245.00
-------------------------------------	--	------------	--------

321 - Harrell Fish, INC (HFI)

17 - repairs to car wash (replaced broken pipes)		03/03/2023	570.00
--	--	------------	--------



# Board of Public Works Claim Register

Invoice Date Range 02/18/23 - 03/03/23

	Account <b>53650 - Other Repairs</b> Totals	Invoice 2 Transactions	\$815.00
<b>Account 53920 - Laundry and Other Sanitation Services</b>			
19171 - Aramark Uniform & Career Apparel Group, INC	17- towel and Mat rentals - 1/18/2023	03/03/2023	77.36
19171 - Aramark Uniform & Career Apparel Group, INC	17 - mat and towel rentals - 2/1/2023	03/03/2023	77.36
19171 - Aramark Uniform & Career Apparel Group, INC	17-city portion of uniform rentals - 2/1/2023	03/03/2023	16.47
19171 - Aramark Uniform & Career Apparel Group, INC	17 - mat and towel rentals - 2/8/2023	03/03/2023	77.36
19171 - Aramark Uniform & Career Apparel Group, INC	17 - city portion of uniform rentals - 2/8/2023	03/03/2023	16.47
	Account <b>53920 - Laundry and Other Sanitation Services</b> Totals	Invoice 5 Transactions	\$265.02
	Program <b>170000 - Main</b> Totals	Invoice 81 Transactions	\$71,731.45
	Department <b>17 - Fleet Maintenance</b> Totals	Invoice 81 Transactions	\$71,731.45
	Fund <b>802 - Fleet Maintenance(\$9500)</b> Totals	Invoice 81 Transactions	\$71,731.45
<b>Fund 804 - Insurance Voluntary Trust</b>			
<b>Department 12 - Human Resources</b>			
<b>Program 120000 - Main</b>			
<b>Account 53990.1271 - Other Services and Charges Section 125 - URM- City</b>			
17785 - The Howard E. Nyhart Company, INC	12-City/Util URM	02/20/2023	213.20
17785 - The Howard E. Nyhart Company, INC	12-City/Util URM	02/20/2023	491.20
17785 - The Howard E. Nyhart Company, INC	12-City URM	02/21/2023	35.42
17785 - The Howard E. Nyhart Company, INC	12-City/Util URM	02/22/2023	261.70
17785 - The Howard E. Nyhart Company, INC	12-City URM	02/23/2023	82.50
	Account <b>53990.1271 - Other Services and Charges Section 125 - URM- City</b> Totals	Invoice 5 Transactions	\$1,084.02
<b>Account 53990.1272 - Other Services and Charges Section 125 - DDC- City</b>			





# Board of Public Works Claim Register

Invoice Date Range 02/18/23 - 03/03/23

17785 - The Howard E. Nyhart Company, INC	12-CityDDC	02/21/2023	560.80
Account <b>53990.1272 - Other Services and Charges Section 125 - DDC- City Totals</b>			Invoice 1 <u>560.80</u>
Transactions			
Account <b>53990.1281 - Other Services and Charges Section 125 - URM- Util</b>			
17785 - The Howard E. Nyhart Company, INC	12-City/Util URM	02/20/2023	60.00
17785 - The Howard E. Nyhart Company, INC	12-City/Util URM	02/20/2023	37.70
17785 - The Howard E. Nyhart Company, INC	12-City/Util URM	02/22/2023	15.00
17785 - The Howard E. Nyhart Company, INC	12-City URM	02/23/2023	25.00
Account <b>53990.1281 - Other Services and Charges Section 125 - URM- Util Totals</b>			Invoice 4 <u>137.70</u>
Transactions			
Account <b>53990.1283 - Other Services and Charges Health Savings Account</b>			
17785 - The Howard E. Nyhart Company, INC	12-Nyhart HSA Employee Contribution 2-24-2023	02/23/2023	23,646.82
Account <b>53990.1283 - Other Services and Charges Health Savings Account Totals</b>			Invoice 1 <u>23,646.82</u>
Transactions			
Program <b>120000 - Main Totals</b>			Invoice 11 <u>25,429.34</u>
Transactions			
Department <b>12 - Human Resources Totals</b>			Invoice 11 <u>25,429.34</u>
Transactions			
Fund <b>804 - Insurance Voluntary Trust Totals</b>			Invoice 11 <u>25,429.34</u>
Transactions			
Fund <b>978 - City 2016 GO Bond Proceeds</b>			
Department <b>06 - Controller's Office</b>			
Program <b>06016G - 2016 G Sanitation Carts</b>			
Account <b>54510 - Other Capital Outlays</b>			
5697 - Cascade Engineering, INC	16-replacement large Sanitation totes & lids	03/03/2023	7,187.50
5697 - Cascade Engineering, INC	16-64 gallon replacement lids for trash,recycle & yardwaste	03/03/2023	15,225.00
Account <b>54510 - Other Capital Outlays Totals</b>			Invoice 2 <u>22,412.50</u>
Transactions			
Program <b>06016G - 2016 G Sanitation Carts Totals</b>			Invoice 2 <u>22,412.50</u>
Transactions			



# Board of Public Works Claim Register

Invoice Date Range 02/18/23 - 03/03/23

Department <b>06 - Controller's Office</b> Totals	Invoice 2	\$22,412.50
	Transactions	
Fund <b>978 - City 2016 GO Bond Proceeds</b> Totals	Invoice 2	\$22,412.50
	Transactions	
Grand Totals	Invoice 291	\$969,408.61
	Transactions	

**REGISTER OF CLAIMS**  
**Board of Public Works Claim Register**

Date:	Type of Claim	FUND	Description	Bank Transfer	Amount
-------	---------------	------	-------------	---------------	--------

<b>03/03/23</b>	Claims				<b>\$969,408.61</b>
-----------------	--------	--	--	--	---------------------

\$969,408.61

**ALLOWANCE OF CLAIMS**

We have examined the claims listed on the foregoing register of claims, consisting of claims, and except for the claims not allowed as shown on the register, such claims are hereby allowed in the total amount of \$969,408.61

**Dated this** 28<sup>th</sup> **day of** February <sup>23</sup> **year of 20**     .

Kyla Cox Deckard, President	Elizabeth Karon, Vice President	Jennifer Lloyd, Secretary

I hereby certify that each of the above listed voucher(s) or bill(s) is (are) true and correct and I have audited same in accordance with IC 5-11-10-1.6.

Fiscal Office \_\_\_\_\_