

AGENDA
REDEVELOPMENT COMMISSION
March 20, 2023 at 5:00 p.m.
Bloomington City Hall, 401 North Morton Street
McCloskey Conference Room, Suite 135

<https://bloomington.zoom.us/j/84424115853?pwd=anNhOTNGWUd1cVhUdW5XeGg2WkRYdz09>

Meeting ID: 844 2411 5853

Passcode: 913590

- I. ROLL CALL**
- II. READING OF THE MINUTES – March 6, 2023**
- III. EXAMINATION OF CLAIMS – March 17, 2023 for \$496,686.29**
- IV. EXAMINATION OF PAYROLL REGISTERS–March 10, 2023 for \$37,123.98**
- V. REPORT OF OFFICERS AND COMMITTEES**
 - A. Director’s Report**
 - B. Legal Report**
 - C. Treasurer’s Report**
 - D. Business Development Updates**
- VI. NEW BUSINESS**
 - A. Resolution 23-25: Approval of Purchase Agreement for Parking Lot Parcels at 216 S. College Avenue.**
 - B. Resolution 23-27: Approval of Match Funding for Resurfacing of Winslow.**
 - C. Resolution 23-28: Approval of Funding for Construction of Griffy Dam Crossing Project**
 - D. Resolution 23-29: Approval of Project Review and Approval Form for a Regional Economic Acceleration and Development Initiative Grant for Hopewell.**
- VII. BUSINESS/GENERAL DISCUSSION**
- VIII. ADJOURNMENT**

Auxiliary aids for people with disabilities are available upon request with adequate notice. Please call [812-349-3429](tel:812-349-3429) or e-mail human.rights@bloomington.in.gov.

***THE REDEVELOPMENT COMMISSION OF THE CITY OF BLOOMINGTON, INDIANA MET on Monday, March 6, 2023, at 5:00 p.m. in the McCloskey Conference Room, 401 North Morton Street, and via Zoom, with RDC President Cindy Kinnarney presiding:
<https://catstv.net/m.php?q=12185>***

I. ROLL CALL

Commissioners Present: Cindy Kinnarney, Randy Cassady, and Deb Hutton attended the meeting in person.

Commissioners Absent: Sarah Bauerle Danzman and Deborah Myerson

Staff Present: John Zody, Director, Housing & Neighborhood Development (HAND); Christina Finley, Financial Specialist, HAND

Others Present: Beth Cate, Corporation Counsel, Legal Department; Chris Wheeler, Attorney, Legal Department; Jeff Underwood, Controller; Alex Crowley, Director, Economic & Sustainable Development; Patrick Dierkes, Project Engineer, Engineering Department; Roy Aten, Senior Project Manager, Engineering Department; Sam Dove;

II. READING OF THE MINUTES – Deb Hutton moved to approve the February 20, 2023 minutes. Randy Cassady seconded the motion. The motion passed unanimously.

III. EXAMINATION OF CLAIM REGISTER – Randy Cassady moved to approve the claim register for March 3, 2023, for \$191,981.79. Deb Hutton seconded the motion. The motion passed unanimously.

IV. EXAMINATION OF PAYROLL REGISTERS – Randy Cassady moved to approve the payroll register February 24, 2023, for \$35,571.22, via roll-call vote. Deb Hutton seconded the motion. The motion passed unanimously.

V. REPORT OF OFFICERS AND COMMITTEES

A. **Director's Report:** John Zody reported that the HOME-ARP allocation plan is up for public comment until March 20, 2023. Zody said staff sent out a request for information for the Hopewell Site and had a site visit for lots 8, 9, and 10 last week.

B. **Legal Report:** Chris Wheeler was available to answer questions.

C. **Treasurer's Report:** Jeff Underwood was available to answer questions.

D. **Business Development Updates:** Alex Crowley stated staff is currently interviewing (exploratory only) owner's representative firms for the Hopewell project. Crowley informed the commission that the Sudbury area has been acquired by a development company.

VI. NEW BUSINESS

A. **Resolution 23-21: Addendum to Design Consultant Contract for Hopewell Phase I East.** The RDC previously approved a design agreement for the Hopewell Phase 1 East with Shrewsberry and Associates for an amount not to exceed \$1,048,888. The RDC also approved a first addendum to the agreement for an additional \$35,637, for a total amount under the contract not to exceed \$1,084,517. Patrick Dierkes said that Shrewsberry and City staff believe it is necessary to execute an addendum to add additional design services and services for re-bidding the construction of the project. City staff have negotiated an addendum to the agreement with

Shrewsberry for an amount not to exceed \$23,745 for the additional services. The total amount of the contract, with the addendum would be \$1,108,262.

The funding authorization contained in this resolution is contingent upon the Board of Public Works approval of the agreement.

Cindy Kinnarney asked for public comment. There were no comments from the public.

Randy Cassady moved to approve Resolution 23-21, via roll-call vote. Deb Hutton seconded the motion. The motion passed unanimously.

- B. Resolution 23-22: Funding for Tree Removal for the B-Line Trail and Multiuse Path Project.** The RDC previously approved a project review and approval form for an extension of the B-Line Trail to a new multi-use path. Roy Aten said part of the project includes tree removal prior to construction. Aten said the City received 4 bids to perform the services and selected Bluestone Tree as the lowest and most responsive bidder. City staff have reached an agreement with Bluestone to perform the services for an amount not to exceed \$48,764.20. The agreement was approved by the Board of Public Works on February 28, 2023.

Cindy Kinnarney asked for public comment. There were no comments from the public.

Deb Hutton moved to approve Resolution 23-22. Randy Cassady seconded the motion. The motion passed unanimously.

- C. Resolution 23-23: Right of Entry for Access to the Fourth Street Garage for Visual Art Exhibition.** The RDC owns vacant commercial space within the Fourth Street Garage located at 105 W. 4th Street. City staff would like to make this space available from March through May, 2023, for a visual arts exhibit. Alex Crowley stated that on March 10, the visual arts collective One Drop would like to begin installing its exhibition in the RDC property for display from March 17 through May 19, 2023. One Drop requires the RDC to grant them a right of entry and release of liability to enter and use the property.

Cindy Kinnarney asked for public comment. There was no comments from the public.

Randy Cassady moved to approve Resolution 23-23. Deb Hutton seconded the motion. The motion passed unanimously.

- D. Resolution 23-24: Second Addendum to Contract for Landscape Maintenance with Nature's Way.** The RDC previously approved an addendum to the agreement with Nature's Way, to add tree trimming and interior plant maintenance services to the agreement, which brought the total amount of the agreement to \$44,000. Alex Crowley said upon inspection of the trees in the Trades District, Nature's Way determined that two trees were dead and needed to be replaced. City staff have brought an addendum to the agreement with Nature's Way, to provide the additional services of tree replacement in the Trade District for an amount not to exceed \$3,000. This would bring the contract amount to a total not to exceed \$47,000.

Cindy Kinnarney asked for public comment. There were no comments from the public.

Deb Hutton moved to approve Resolution 23-24. Randy Cassady seconded the motion. The motion passed unanimously.

- E. Resolution 23-26: Approval of Amendment for Final Plat for Trades District Lot 2.** Beth Cate said to facilitate the development of the remainder of the original Lot 2, the City has

proposed to divide Lot 2 into Lots 2A and 2B and provide a UDO-compliant pedestrian easement running east-west in Lot 2A.

Cindy Kinnarney asked for public comment. There were no comments from the public.

Randy Cassady moved to approve Resolution 23-26. Deb Hutton seconded the motion. The motion passed unanimously.

VII. BUSINESS/GENERAL DISCUSSION – None.

VIII. ADJOURNMENT – Deb Hutton moved to adjourn. Randy Cassady seconded the motion. The meeting adjourned at 5:25 p.m.

Cindy Kinnarney, President

Deborah Myerson, Secretary

Date: _____

23-25
RESOLUTION
OF THE
REDEVELOPMENT COMMISSION
OF THE
CITY OF BLOOMINGTON, INDIANA

**APPROVAL OF PURCHASE AGREEMENT FOR
PARKING LOT PARCELS AT 216 SOUTH COLLEGE AVENUE**

WHEREAS, pursuant to Indiana Code 36-7-14 *et seq.*, the Redevelopment Commission of the City of Bloomington (“RDC”) and the Common Council of the City of Bloomington created an economic development area known as the Consolidated Economic Development Area (“Consolidated TIF”), the purpose of which is to facilitate economic development and revitalization in Bloomington; and

WHEREAS, the Consolidated TIF is an allocation area for purposes of tax increment financing; and

WHEREAS, pursuant to Indiana Code § 36-7-14-19, the RDC is vested with the power to acquire real property; and

WHEREAS, in Resolution 19-34, the RDC approved a purchase agreement for the real estate located at 216 S. College Avenue; and

WHEREAS, as part of the purchase, the RDC assumed leases that were part of 216 S. College Avenue, which included a lease for two parcels of land that made up a portion of the parking lot (“Property”), with the following legal description:

- 013-40720-00 ORIGINAL PLATS LOT[S] 43 & 44; and

WHEREAS, City Staff has negotiated an offer to purchase the Property for One Million Nine Hundred Thousand Dollars (\$1,900,000), a copy of which is attached to this Resolution as Exhibit A (“Purchase Agreement”); and

WHEREAS, Staff has brought the RDC a Project Review and Approval Form (“Form”) regarding this project, which is attached to this Resolution as Exhibit B; and

WHEREAS, there are sufficient funds in the TIF to cover the expenses above;

NOW, THEREFORE, BE IT RESOLVED BY THE REDEVELOPMENT COMMISSION OF THE CITY OF BLOOMINGTON, INDIANA, THAT:

1. The RDC affirms its support of the purchase, as set forth in the Form, and reiterates that it serves the public’s best interests.

2. The RDC finds that the acquisition of the Property is an appropriate use of the bonding authority of the RDC and Consolidated TIF funds.
3. The RDC explicitly approves the Purchase Agreement. This approval shall not be interpreted as satisfaction of any of the other required contingencies.
4. The RDC hereby authorizes the Controller to expend an amount not to exceed One Million Nine Hundred Thousand Dollars (\$1,900,000) plus any itemized and necessary closing costs for the purchase of the Property in accordance with the Purchase Agreement from the Consolidated TIF fund. Nothing in this Resolution shall remove the requirement to comply with the City or the RDC's claims process.
5. The RDC hereby authorizes its president, Cindy Kinnarney, to sign any and all documents necessary for closing on its behalf.
6. Unless extended by the Redevelopment Commission in a resolution prior to expiration, the authorizations provided under this Resolution shall expire on December 31, 2023.

BLOOMINGTON REDEVELOPMENT COMMISSION

Cindy Kinnarney, President

ATTEST:

Deborah Myerson, Secretary

Date

AGREEMENT FOR PURCHASE OF REAL ESTATE

THIS AGREEMENT FOR PURCHASE OF REAL ESTATE AND ASSETS, is made by and between The City of Bloomington, Indiana, and its Redevelopment Commission (collectively, “Purchaser”), and Thomas A. Sicks and Nancy Held (“Sellers”).

RECITALS

- A. The Sellers own real property and improvements (hereinafter referred to as “Real Estate”) in Monroe County, Indiana, which is more particularly described as follows:

Parcel No.	Legal Description	Acreage
53-05-33-310-243.000-005	013-40720-00 ORIGINAL PLATS LOT 43 & 44	0.40

- B. Pursuant to Indiana Code Section 36-1-11-3, the Sellers desire to convey the Real Estate to Purchaser and, pursuant to its governing authority, Purchaser desires to accept the Real Estate and any and all improvements located on the Real Estate, subject and according to the terms and conditions of this Agreement.

TERMS AND CONDITIONS

In consideration of the payment of the purchase price set forth herein and other good and valuable consideration, the receipt and sufficiency of which are hereby acknowledged, and the mutual covenants herein contained, Sellers and Purchaser agree as follows:

1. **Purchaser Approval.** This Agreement is contingent upon approval by the Bloomington Redevelopment Commission within thirty (30) days from the Effective Date. In the event that the Redevelopment Commission, in its sole discretion, does not approve the Purchase Agreement within thirty (30) days following acceptance of the Purchase Agreement by SELLER, the Purchase Agreement is rescinded and the sale is terminated. This approval is separate and distinct from the other Conditions in the Purchase Agreement, Due Diligence, Financing and Statutorily Required Process.
2. **Purchase Price and Payment.** The purchase price for the Property (the “Purchase Price”) shall be One Million Nine Hundred Thousand Dollars (\$1,900,000.00). The Purchase Price shall be paid by Purchaser to Sellers at the Closing by certified check or cashier’s check, or by wire transfer.
3. **Conditions Precedent to Closing.** Purchaser's obligations hereunder shall be subject to the condition that as of the Closing Date there is no breach of any of Seller's representations or warranties hereunder and to the satisfaction of the following additional conditions precedent which shall be determined during the Due Diligence Period which shall be up to ninety (90) days from the Effective Date, except as expressly otherwise specified herein or agreed by the Parties:

- 3.1 **No Encroachment.** There will be no encroachments thereon and no existing violations of zoning ordinances or other restrictions applicable to the Real Estate.
- 3.2 **Title Evidence and Insurance.** Sellers shall provide, at Sellers' expense, a commitment for an owner's title insurance policy satisfactory to Purchaser insuring the full amount of the Purchase Price. The title insurance commitment shall disclose marketable title in Sellers. Purchaser shall notify Sellers within thirty (30) days of receipt of the commitment of any objections to the title. Such title shall be deemed acceptable when it is capable of being transferred into the name of Purchaser subject only to:
- a. Taxes which Purchaser has agreed to pay and any other assessments which Purchaser has agreed in writing to pay;
 - b. Liens which Purchaser has agreed in writing to pay;
 - c. Zoning ordinances and other governmental restrictions affecting the use of the property, provided that no violations now exist; and
 - d. Recorded easements which Purchaser has agreed in writing to pay.
- 3.3 **Environmental Conditions.** Purchaser may obtain, at its sole expense, one or more environmental reviews of the Real Estate. In the event that Purchaser obtains one or more environmental reviews of the Real Estate, this offer is contingent upon the Purchaser's satisfaction with the environmental conditions of the Real Estate. The Purchaser shall have ninety (90) days to obtain environmental reviews of the Real Estate and to affirmatively accept or reject—in its sole discretion—the environmental conditions of the Real Estate. If the Purchaser does not affirmatively reject the environmental conditions of the Real Estate within that time period, Purchaser shall be deemed to have accepted the environmental conditions of the Real Estate.
- 3.4 **Representations and Warranties.** Sellers represent and warrant to the Purchaser, and shall be deemed to represent and warrant to the Purchaser on the closing date, that, as of the closing date and to the best of Sellers' knowledge and belief:
- 3.4.1 Sellers have not created, permitted or suffered any lien or other encumbrance to attach to or affect the Real Estate and improvements thereon, except for the lien of non-delinquent real estate taxes;
 - 3.4.2 There are no claims, actions, suits, proceedings or investigations pending or threatened with respect to or in any manner affecting the Real Estate or Sellers' ownership thereof;
 - 3.4.3 No work has been performed or is in progress at, and no materials have been furnished to, the Real Estate or any portion thereof which is presently the

subject of or which might give rise to mechanics', materialmen's or other liens affecting the Real Estate or any portion thereof;

- 3.4.4 Prior to the closing, Sellers shall not sell, assign, transfer, lease sublease encumber or convey any right, title or interest whatsoever in or to the Real Estate or any portion thereof without the Purchaser's prior written consent, nor shall Sellers amend, modify, terminate or alter any currently existing agreement or document relating to the Real Estate without the Purchaser's prior written consent;
 - 3.4.5 Sellers know of no facts nor have Sellers misrepresented or failed to disclose any facts which materially adversely affect the value of the Real Estate; and
 - 3.4.6 Sellers shall deliver possession of the Real Estate to the Purchaser on the closing date, free and clear of all rights and claims of any other party to the possession, use, ownership or control of the Real Estate except as agreed to by Purchaser in writing.
- 3.5 **Right to Inspect.** Purchaser and its representatives shall have the right to enter upon the Real Estate and conduct all tests and examinations which they deem necessary, including any environmental evaluations, unless otherwise stated. Purchaser, at Purchaser's sole expense, shall restore or repair any damage to the Real Estate, including but not limited to soil borings or other holes in the ground, caused by Purchaser's inspections, testing or environmental reviews no later than seven (7) days prior to closing or fourteen (14) days following termination of this Agreement.
- 3.6 **No Litigation.** Except as provided herein, as of the closing date, no action or proceeding relating to the Real Estate shall be pending before a court or other governmental agency or officer, and to the best of Sellers' knowledge and belief, no such action or proceeding is or shall be threatened.
- 3.7 **Survey.** Purchaser may, at its option, obtain an ALTA/ACSM survey of the Real Estate satisfactory to Purchaser showing the location of all improvements, encroachments and easements located thereon. Purchaser shall bear the expense of the survey.
- 3.8 **Real Estate Taxes.** Purchaser shall be responsible for paying the Real Estate's property taxes assessed in or after 2022 (payable in or after 2023).
- 3.9 **Broker's Fees.** Purchaser and Seller shall each be responsible for the payment of their own advisors and professionals they have used relating to the execution of this transaction.

4. **Default.** If Sellers, through no fault of Sellers, are unable to convey marketable title as required by this Agreement, and the defect or defects are not waived by Purchaser, Sellers' sole obligation shall be to return promptly any sums expended by Purchaser for the survey; provided, however, Purchaser shall have the right to pay and satisfy any existing liens not otherwise assumed by Purchaser and deduct that amount from the Purchase Price. If Sellers refuse to perform as required, then the Purchaser may pursue all available legal and equitable remedies.

If Purchaser refuses to perform as required by this Agreement, then Sellers may elect to pursue all available legal or equitable remedies.

5. **Closing and Possession.** Closing shall take place at a time, date and location agreed upon by the Parties within thirty (30) days of the Redevelopment Commission's acceptance of the environmental conditions of the Real Estate under Section 3.3, unless extended by mutual agreement. Costs of closing, except those specified elsewhere in this Agreement, shall be shared between Purchaser and Sellers. At Closing, Sellers shall deliver to Purchaser an executed General Warranty Deed in recordable form conveying marketable title to the Real Estate subject only to exceptions permitted by this Agreement, together with an executed Vendor's Affidavit, Sales Disclosure Statement as required by I.C. § 6-1.1-5.5, et seq.; and any such other instrument, document and considerations as may reasonably be required by Purchaser or Purchaser's counsel to effectuate this Agreement. All of the documents and instruments required by this Agreement shall be in a form acceptable to Purchaser and Sellers. Possession of the Real Estate shall be delivered to the Purchaser on the date of Closing, and the Lease Addendum shall remain in full force and effect until possession is transferred.

6. **Sellers' Legal Authority.** The Sellers, individually and collectively, represent to Purchaser that all necessary legal action to authorize, empower, or otherwise enter into this transaction has occurred, and that each signatory below can obligate and bind their respective performance hereunder.

7. **Survival of Representation and Warranties.** All representations and warranties made herein shall survive the Closing of the transaction provided for herein.

8. **Risk of Loss; Condemnation.** All risk of loss or damage to the Property occurring subsequent to the date hereof shall be borne by Sellers to and including the Closing Date. If any of the Property shall suffer a loss by fire, flood, tornado, accident or other cause after the date hereof and on or before the Closing Date, or if proceedings to take or condemn the whole or any part of the Property for public or quasi-public use under any statute or by the right of eminent domain are commenced or threatened prior to the Closing Date, then Purchaser may, at its sole option, either consummate or not consummate the transaction contemplated hereby. If Purchaser elects to consummate such transaction, then all insurance proceeds payable in respect of such casualty and/or any and all damages or awards payable in respect of such taking or condemnation shall be paid to Purchaser. If Purchaser elects not to consummate such transaction, this Agreement shall terminate and be of no further force and effect.

9. **Assignment.** Neither party may assign its interest in this Agreement without the prior written consent of the other party.
10. **Survival.** All representations and warranties of the parties made herein shall be and remain true at the time of the Closing and shall survive the Closing for a period of six (6) months and the conveyance of the Property to Purchaser, and shall not be deemed to be merged into the deed to be delivered by Sellers to Purchaser hereunder.
11. **Binding on Successors.** This Agreement shall be binding upon and shall inure to the benefit of the parties hereto and their respective heirs, representative, successors and permitted assigns.
12. **Counterparts.** This Agreement may be executed in any number of counterparts, each of which shall be deemed an original, but all of which together shall constitute one and the same agreement.
13. **Modification.** This agreement may not be changed or modified except by an agreement in writing signed by the party sought to be charged with such modification.
14. **Waiver.** No failure on the part of either party to exercise any power or right given hereunder or to insist upon strict compliance with any obligations specified herein, and no custom or practice at variance with the terms hereof, shall constitute a waiver of either party's right to demand exact compliance with the terms hereof; provided, however, that either party may, at its sole option, waive in writing any requirement, covenant or condition herein established for the benefit of such party without affecting any of the other terms or provisions of this Agreement. No delay on the part of either party in the exercise of any power or right hereunder shall operate as a waiver thereof nor shall any single or partial exercise of any power or right preclude other or further exercise thereof or the exercise of any power or right. All rights and remedies existing under this Agreement shall be cumulative and shall be in addition to those otherwise provided by law.
15. **Entire Agreement.** This Agreement constitutes the entire agreement among the parties hereto and supersedes all prior discussions, letters of intent, agreements, writings and representations between Sellers and Purchaser with respect to the Property and the transaction contemplated herein.
16. **Governing Law.** This Agreement shall be governed by the laws of the State of Indiana.

[Signature Page Follows]

IN WITNESS WHEREOF, Purchaser and Sellers have executed this Agreement as of the date first hereinabove written.

"SELLERS"

Thomas A. Sicks and Nancy Held

By: _____
Nancy Held

Date: _____

By: _____
Thomas A. Sicks

Date: _____

"PURCHASER"

**REDEVELOPMENT COMMISSION OF
BLOOMINGTON, INDIANA**

By: _____
Cindy Kinnarney, President

Date: _____

THE CITY OF BLOOMINGTON

By: _____
Beth Cate, Corporation Counsel

Date: _____

City of Bloomington
 Redevelopment Commission
 Project Review & Approval Form

Please Note:

- Approval of the project by the Redevelopment Commission through this Project Review & Approval Form does not represent an authorization to begin work or expend funds.
- Authorization of work and the commitment of funds shall be done when the Redevelopment Commission reviews and approves: (1) a Purchase Order or Contract prepared after complying with the appropriate procurement process for the type of item, service or construction being sought and (2) the estimated costs associated with the Purchase Order or Contract.
- No payment of funds shall be made without a duly authorized and approved Purchase Order or Contract. All claims for payment against a duly authorized Purchase Order or Contract shall be submitted to the Redevelopment Commission for their review and approval along with any required departmental inspections, reviews and approvals prior to the payment of any funds.

To Be Completed by Requesting Party:

Project Name: Property Acquisition of parcels that are part of parking lot at 216 S. College Avenue (Lots 43 and 44 of the Original Plat – Tax ID 013-40720-00).

Project Description:

This project proposes to acquire property adjacent to 216 S. College Avenue (within Consolidated TIF District – Downtown Area) to be redeveloped in a manner consistent with the other property owned by the Redevelopment Commission.

The acquisition of property is an appropriate use of Tax Increment Financing.

Project Timeline:

Start Date: March 2023

End Date: June 2023

Financial Information:

Estimated full cost of project:	\$1,900,000
Sources of funds:	
Consolidated TIF	\$1,900,000

Project Phases: This breakdown should mirror the contract(s) expected to be issued for this project. Each phase should include a description of the work to be performed, the cost, and the timeline for the contract.

Step	Description	Estimated Cost	Timeline
1	Property Acquisition	\$1,900,000	June 2023

TIF District: Consolidated TIF (Downtown)

Resolution History: 23-25 Approval of Purchase Agreement and Project Review and Approval Form

To Be Completed by Redevelopment Commission Staff:

Approved on _____

By Resolution _____ by a vote of _____

23-27
RESOLUTION
OF THE
REDEVELOPMENT COMMISSION
OF THE
CITY OF BLOOMINGTON, INDIANA

APPROVAL OF MATCH FUNDING FOR RESURFACING OF WINSLOW

- WHEREAS, pursuant to Indiana Code 36-7-14 *et seq.*, the Redevelopment Commission of the City of Bloomington (“RDC”) and the Common Council of the City of Bloomington created an economic development area known as the Consolidated Economic Development Area (“Consolidated TIF”); and
- WHEREAS, Indiana Code § 36-7-14-39 permits TIF funds to be used either directly by the RDC or in reimbursing the City for local public improvements, which includes infrastructure development; and
- WHEREAS, on September 5, 2022, the RDC approved in Resolution 22-60 a Project Review and Approval Form (“Form”) to provide a local match of up to \$500,000 for the local public improvement of resurfacing Winslow Road from west of Walnut Street to Allendale Street, which will include making improvements for ADA compliant curb ramps, improvements to sidewalk sections, and improving safety at the intersection of Winslow and Allendale (“Project”); and
- WHEREAS, the Project, when completed, will serve the Consolidated TIF; and
- WHEREAS, the full cost of the Project will be funded from a mix funding including a Community Crossing Grant from the Indiana Department of Transportation (“INDOT”), City budgetary funds, and local matching funds from the Consolidated TIF; and
- WHEREAS, the City received two qualifying bids for the projects, and selected Milestone Contractors, LP (“Milestone”) as the lowest responsive and responsible bidder; and
- WHEREAS, incorporated into and attached to this Resolution as Exhibit A is an agreement with Milestone to provide the services for the Project for an amount not to exceed \$474,712.00; and
- WHEREAS, the local matching funds from the Consolidated TIF are 50% of the total costs, which amounts to an amount not to exceed \$237,356.00; and
- WHEREAS, this Project is connected to the Consolidated TIF – Walnut-Winslow Area, which extends beyond W Country Club Drive and East Winslow Road to the south, and from just west of the B-Line Trail to the west to just past South Henderson Street to the east; and
- WHEREAS, the RDC has available funds in the Consolidated TIF to cover the local matching portion of the Project; and

WHEREAS, the City has brought the RDC an Amended Project Review and Approval Form (“Amended Form”) which is attached to this Resolution as Exhibit B.

NOW, THEREFORE, BE IT RESOLVED BY THE REDEVELOPMENT COMMISSION OF THE CITY OF BLOOMINGTON, INDIANA, THAT:

1. The RDC reaffirms its approval of the Project, as set forth in more detail on the Amended Form.
2. The RDC reiterates that the Project is an appropriate use of the Consolidated TIF, because the Project is connected to the Consolidated TIF, will enhance infrastructure in the area, and will serve the public’s best interests.
3. The RDC hereby approves funding in an amount not to exceed Two Hundred Thirt-Seven Thousand Three Hundred Six Dollars (\$237,356.00) from the Consolidated TIF for the construction phase of the Project. The funding authorization contained in this Paragraph shall terminate on December 31, 2023, unless otherwise extended by the RDC.

BLOOMINGTON REDEVELOPMENT COMMISSION

Cindy Kinnarney, President

ATTEST:

Deborah Myerson, Secretary

Date



Board of Public Works Staff Report

Project/Event:	Award Construction Agreement for Winslow Resurfacing Project
Petitioner/Representative:	Engineering Department
Staff Representative:	Matt Smethurst
Date:	March 14th, 2023

Report: This project shall include the milling and resurfacing of asphalt pavement on Winslow Road from Walnut Street to Allendale Drive. The project will also install ADA compliant curb ramps at five intersections, make improvements to sections of sidewalk, and improve safety at the Winslow/Allendale intersection by altering the intersection layout. Bids were opened at a public meeting on March 13th, 2023. The City received two bids:

- Milestone Contractors, LP- \$474,712.00
- E & B Paving, LLC- \$549,300.00

Milestone Contractors, LP were the lowest responsive and responsible bidder. Construction is anticipated to begin in the spring of 2023. Single lane restrictions will be in place during construction utilizing flaggers. This project is TIF funded and will require RDC approval.

**AGREEMENT
BETWEEN
CITY OF BLOOMINGTON
ENGINEERING DEPARTMENT
AND
MILESTONE CONTRACTORS, LP
FOR
Winslow Resurfacing Project (Walnut to Allendale)**

THIS AGREEMENT, executed by and between the City of Bloomington, Indiana, Engineering Department through the Board of Public Works (hereinafter CITY), and Milestone Contractors, LP, (hereinafter CONTRACTOR);

WITNESSETH THAT:

WHEREAS, CITY desires to retain CONTRACTOR'S services for the milling and resurfacing of asphalt pavement, and the installation of sidewalk, curb, ADA compliant ramps, and pavement markings on Winslow Road, (more particularly described in Attachment A, "Scope of Work"; and

WHEREAS, CONTRACTOR is capable of performing work as per his/her Bid on the Bid Summary sheet; and

WHEREAS, in accordance with Indiana Code 5-16-13 *et seq.*, incorporated herein by reference, Contractor is a Tier 1 or General Contractor for this project; and

WHEREAS, CONTRACTOR was determined to be the lowest responsible and responsive Bidder for said project.

NOW, THEREFORE, in consideration of the mutual promises hereinafter enumerated, the parties agree as follows:

ARTICLE 1. TERM

1.01. This Agreement shall be in effect upon execution of this Agreement by all parties. In accordance with Indiana Code 5-16-13 *et seq.*, incorporated herein by reference, Contractor is a Tier 1 contractor or general contractor for this project.

ARTICLE 2. SERVICES

2.01 Contractor shall complete all Work as specified or indicated in the Contract Documents. The Work is generally described in Attachment A, "Scope of Work".

2.02. All work required under this Agreement shall be substantially completed by the CONTRACTOR within ninety (90) calendar days from the date of the Notice to Proceed, unless the parties mutually agree to a later completion date. Substantial Completion shall mean that all work is sufficiently completed in accordance with the plans and specifications, as modified by any approved change orders, so that it can be used for its intended purpose.

2.03. It is hereby understood by both parties that time is of the essence in this Agreement. Failure of CONTRACTOR to complete all work as herein provided will result in monetary damages to CITY. It is hereby agreed that CITY will be damaged for every day the work has not been performed in the manner herein provided and that the measure of those damages shall be determined by reference Section 13.00 of the General Conditions for Each Day of Overrun in Contract Time. CONTRACTOR agrees to pay CITY said damages or, in the alternative, CITY, at its sole discretion, may withhold monies otherwise due CONTRACTOR. It is expressly understood by the parties hereto that these damages relate to the time of performance and do not limit CITY's other remedies under this Agreement, or as provided by applicable law, for other damages.

2.04. CONTRACTOR agrees that no charges or claims for damages shall be made by him or her for any delays or hindrances, from any cause whatsoever during the progress of any portion of the services specified in the Agreement. Such delays or hindrances, if any, may be compensated for by an extension of time for a reasonable period as may be mutually agreed upon between the parties, it being understood, however, that permitting CONTRACTOR to proceed to complete any service, or any part of the services / project, after the date to which the time of completion may have been extended, shall in no way operate as a waiver on the part of CITY of any of its rights herein.

ARTICLE 3. COMPENSATION

3.01. CONTRACTOR shall provide services as specified in Attachment A, "Scope of Work", attached hereto and incorporated into this Agreement.

3.02. Owner shall pay Contractor for completion of the Work in accordance with the Contract Documents, subject to adjustment under the Contract, at the unit prices stated in Contractor's Bid, attached hereto as Attachment 'E'. CITY may withhold payment, in whole or in part, to the extent necessary to protect itself from a loss on account of any of the following:

Defective work.

Evidence indicating the probable filing of claims by other parties against CONTRACTOR which may adversely affect CITY.

Failure of CONTRACTOR to make payments due to subcontractors, material suppliers or employees.

Damage to CITY or a third party.

3.03. The submission of any request for payment shall be deemed a waiver and release by CONTRACTOR of all liens and claims with respect to the work and period to which such payment request pertains except as specifically reserved and noted on such request.

3.04. CONTRACTOR shall maintain proper account records for the scope of all services of this Agreement and provide an accounting for all charges and expenditures as may be necessary for audit purposes. All such records shall be subject to inspection and examination by CITY's representatives at reasonable business hours.

3.05 For projects utilizing federal funding the CONTRACTOR shall submit time sheets (WH-347) for his or her own and all subcontracted employees, to City Engineer or his or her representative for approval and review, including review for compliance with Davis Bacon requirements, if federal funds are used.

3.06 Engineer The City Engineer shall act as the CITY's representative and assume all duties and responsibilities and have all the rights and authority assigned to the Engineer in the Contract Documents in connection with completion of the Work in accordance with the Contract Documents.

ARTICLE 4. RETAINAGE

For contracts in excess of \$100,000 and for which Contractor requested Progressive Payments on its Bid Form, the Owner requires that retainage be held set out below.

4.01 Escrow Agent The retainage amount withheld shall be placed in an escrow account. First Financial Bank, Bloomington, Indiana, shall serve as the escrow agent.

4.02 Retainage Amount The escrow agent, Owner and Contractor shall enter into a written escrow agreement. Under that agreement, the Owner shall withhold five percent (5%) of the dollar value of all work satisfactorily completed until the Contract work is complete. The escrow agent shall invest all escrowed principal in obligations selected by the escrow agent. The escrow agent shall be compensated for the agent's services by a reasonable fee, agreed upon by the parties, that is comparable with fees charged for the handling of escrow accounts of similar size and duration. The fee shall be paid from the escrow income. The escrow agent's fee may be determined by specifying an amount of interest the escrow agent will pay on the escrowed amount, with any additional earned interest serving as the escrow agent's fee. The escrow agreement may include other terms and conditions as deemed necessary by the parties. However, if Contractor intends to receive a Single Lump Sum payment upon acceptance of this project, retainage will not be required and an Escrow Agreement will not be required.

4.03 Payment of Escrow Amount The escrow agent shall hold the escrowed principal and income until receipt of the notice from the Owner and Contractor that the Contract work has been substantially completed to the reasonable satisfaction of the Owner, at which time the Owner shall pay to the Contractor the balance to be paid under this Contract and execute such documents as are necessary to authorize the escrow agent to pay to the Contractor the funds in the escrow account, including both specifying the part of the escrowed principal to be released from the escrow and the person to whom that portion is to be released. After receipt of the notice, the escrow agent shall remit the designated part of the escrowed principal and the escrowed income, minus the escrow agent's fees, to the person specified in the notice. However, nothing in this section shall prohibit Owner from requiring the escrow agent to withhold amounts necessary to complete minor items of the Contract, following substantial completion of the Contract in accordance with the provisions of paragraph 4.04.

4.04 Withholding Funds for Completion of Contract If, upon substantial completion of the Contract, there still remains minor Contract work that needs to be completed, or minor Contract work that needs to be performed to the satisfaction of the Owner, Owner may direct the escrow agent to retain in the escrow account, and withhold from payment to the Contractor, an amount equal to two hundred percent (200%) of the value of said work. The value of said work shall be determined by the architect/engineer. The escrow agent shall release the funds withheld under this section after receipt of notice from the Owner that all work on the Contract has been satisfactorily completed. In the event that said work is not completed by the Contractor, but by Owner or another party under contract with the Owner, said funds shall be released to the Owner.

ARTICLE 5. GENERAL PROVISIONS

5.01. CONTRACTOR agrees to indemnify and hold harmless CITY and its officers, agents, officials and employees for any and all claims, actions, causes of action, judgments and liens arising out of any negligent act or omission by CONTRACTOR or any of its officers, agents, officials, employees, or subcontractors or any defect in materials or workmanship of any supply, materials, mechanism or other product or service which it or any of its officers, agents, officials, employees, or subcontractors has supplied to CITY or has used in connection with this Agreement and regardless of whether or not it is caused in part by a party indemnified herein under. Such indemnity shall include attorney's fees and all costs and other expenses arising there from or incurred in connection therewith and shall not be limited by reason of the enumeration of any insurance coverage required herein.

CONTRACTOR shall indemnify and hold harmless CITY and its officers, agents, officials and employees for any and all damages, actions, costs, (including, but not limited to, attorney's fees, court costs and costs of investigation) judgments and claims by anyone for damage to property, injury or death to persons resulting from the collapse or failure of any trenches, ditches or other excavations constructed under or associated with this contract.

5.02 Abandonment, Default and Termination

5.02.01 CITY shall have the right to abandon the work contracted for in this Agreement without penalty. If CITY abandons the work described herein, CONTRACTOR shall deliver to CITY all surveys, notes, drawings, specifications and estimates completed or partially completed and these shall become the property of CITY. The earned value of the work performed shall be based

upon an estimate of the proportion between the work performed by CONTRACTOR under this Agreement and the work which CONTRACTOR was obligated to perform under this Agreement. This proportion shall be mutually agreed upon by CITY and CONTRACTOR. The payment made to CONTRACTOR shall be paid as a final payment in full settlement of his or her services hereunder.

5.02.02 If CONTRACTOR defaults or fails to fulfill in a timely and proper manner the obligations pursuant to this Agreement, CITY may, after seven (7) days' written notice has been delivered to CONTRACTOR, and without prejudice to any other remedy it may have, make good such deficiencies and may deduct the cost thereof from the payment then or thereafter due to CONTRACTOR. In the alternative, CITY, at its option, may terminate this Agreement and take possession of the site and of all materials, equipment, tools and construction equipment and machinery thereon owned by CONTRACTOR, and may finish the project by whatever method it may deem expedient, and if the such action exceeds the unpaid balance of the sum amount, CONTRACTOR or his or her surety, shall pay the difference to CITY.

5.02.03 Default: If CONTRACTOR breaches this Agreement or fails to perform the work in an acceptable manner, he or she shall be considered in default. Any one or more of the following will be considered a default:

Failure to begin the work under this Agreement within the time specified.

Failure to perform the work with sufficient supervision, workmen, equipment and materials to insure prompt completion of said work within the time limits allowed.

Unsuitable performance of the work as determined by CITY ENGINEER or his or her representative.

Neglecting or refusing to remove defective materials or failure to perform anew such work as shall have been rejected.

Discontinuing the prosecution of the work or any part of it.

Inability to finance the work adequately.

If, for any other reason, CONTRACTOR breaches this Agreement or fails to carry on the work in an acceptable manner.

5.02.04 CITY shall send CONTRACTOR a written notice of default. If CONTRACTOR, or his or her Surety, within a period of ten (10) days after such notice, fails to remedy the default, then CITY shall have full power and authority, without violation of the Contract, to take the prosecution of the work out of the hands of said CONTRACTOR, to appropriate or use any or all materials and equipment on the ground as may be suitable and acceptable, and may, at its option, turn the work over to the Surety, or enter into an agreement with another Contractor for the completion of the Agreement according to the terms and provisions thereof, or CITY may use such other methods as, in its opinion, shall be required for the completion of said Contract in an acceptable manner.

5.02.05 All cost of completing the work under the Contract shall be deducted from the monies due or which may become due to said CONTRACTOR. In case the expenses so incurred by CITY shall be less than the sum which would have been payable under the Contract if it had been completed by said CONTRACTOR, CONTRACTOR shall be entitled to receive the difference. However, in case such expense shall exceed the sum which would have been payable under the Contract, CONTRACTOR and his or her Surety will be liable and shall pay to CITY the amount of said excess. By taking over the prosecution of the work, CITY does not forfeit the right to recover damages from CONTRACTOR or his or her Surety for his or her failure to complete the work in the time specified.

5.02.06 Notwithstanding any other provision of this Agreement, if funds for the continued fulfillment of the Agreement by CITY are at any time not forthcoming or are insufficient, through failure of any entity to appropriate the funds or otherwise, then CITY shall have the right to terminate this Agreement without penalty by giving prior written notice documenting the lack of funding in which instance, unless otherwise agreed to by the parties, this Agreement shall terminate and become null and void.

5.02.07 CITY agrees that it will make its best effort to obtain sufficient funds, including but not limited to, including in its budget for each fiscal period during the term hereof a request for sufficient funds to meet its obligations hereunder in full.

5.03. Successors and Assigns

5.03.01 Both parties agree that for the purpose of this Agreement, CONTRACTOR shall be an Independent Contractor and not an employee of CITY.

5.03.02 No portion of this Agreement shall be sublet, assigned, transferred or otherwise disposed of by CONTRACTOR except with the written consent of CITY being first obtained. Consent to sublet, assign, transfer, or otherwise dispose of any portion of this Agreement shall not be construed to relieve CONTRACTOR of any responsibility of the fulfillment of this Agreement.

5.04. Extent of Agreement: Integration

5.04.01 This Agreement consists of the following parts, each of which is as fully a part of this Agreement as if set out herein:

1. This Agreement and its Attachments.
2. All Written Amendments and other documents amending, modifying, or supplementing the Contract Documents which may be delivered or issued after the Effective Date of the Agreement and are not attached hereto.
3. All Addenda to the Bid Documents.
4. The Invitation to Bidders.
5. The Instructions to Bidders.
6. The Special Conditions.
7. All plans as provided for the work that is to be completed.
8. The Supplementary Conditions.
9. The General Conditions.

10. The Specifications.
11. The current Indiana Department of Transportation Standard Specifications and the latest addenda.
12. CONTRACTOR'S submittals.
13. The Performance Bond and the Payment Bond.
14. The Escrow Agreement.
15. Request for Taxpayer Identification number and certification: Substitute W-9.

5.04.02 In resolving conflicts, errors, discrepancies and disputes concerning the Scope of Work to be performed by CONTRACTOR, and other rights and obligations of CITY and CONTRACTOR, the document expressing the greater quantity, quality or other scope of work in question, or imposing the greater obligation upon CONTRACTOR and affording the greater right or remedy to CITY shall govern; otherwise the documents shall be given precedence in the order as enumerated above.

5.05. Insurance

5.05.01

CONTRACTOR shall, as a prerequisite to this Agreement, purchase and thereafter maintain such insurance as will protect him or her from the claims set forth below which may arise out of or result from CONTRACTOR'S operations under this Agreement, whether such operations be by CONTRACTOR or by any SUBCONTRACTORS or by anyone directly or indirectly employed by any of them, or by anyone for whose acts any of them may be liable:

<u>Coverage</u>	<u>Limits</u>
A. Worker's Compensation & Disability	Statutory Requirements
B. Employer's Liability Bodily Injury by Accident	\$100,000 each accident
Bodily Injury by Disease	\$500,000 policy limit
Bodily Injury by Disease	\$100,000 each employee
C. Commercial General Liability (Occurrence Basis)	\$1,000,000 per occurrence
Bodily Injury, personal injury, property damage,	and \$2,000,000 in the
contractual liability, products-completed operations,	aggregate
General Aggregate Limit (other than Products/Completed	
Operations)	
Products/Completed Operation	\$1,000,000
Personal & Advertising Injury Limit	\$1,000,000
Each Occurrence Limit	\$1,000,000
Fire Damage (any one fire)	\$50,000
D. Comprehensive Auto Liability (single limit,	\$1,000,000 each accident
owned, hired and non-owned)	
Bodily injury and property damage	
E. Umbrella Excess Liability	\$5,000,000 each
	occurrence and aggregate
The Deductible on the Umbrella Liability shall not	
be more than	\$10,000

5.05.02 CONTRACTOR'S comprehensive general liability insurance shall also provide coverage for the following:

- Premises and operations;
- Contractual liability insurance as applicable to any hold-harmless agreements;
- Completed operations and products; which also must be maintained for a minimum period of two (2) years after final payment and CONTRACTOR shall continue to provide evidence of such coverage to CITY on an annual basis during the aforementioned period;
- Broad form property damage - including completed operations;
- Fellow employee claims under Personal Injury; and
- Independent Contractors.

5.05.03 With the prior written approval of CITY, CONTRACTOR may substitute different types or amounts of coverage for those specified as long as the total amount of required protection is not reduced.

5.05.04 Certificates of Insurance showing such coverage then in force (but not less than the amount shown above) shall be on file with CITY prior to commencement of work. These Certificates shall contain a provision that coverage afforded under the policies will not be canceled or non-renewed until at least sixty (60) days' prior written notice has been received by CITY. The CITY shall be named as an additional insured on the Commercial General Liability, Automobile Liability, and Umbrella Excess Liability policies. The CONTRACTOR shall agree to a waiver of subrogation on its Worker's Compensation policy.

5.06. Necessary Documentation CONTRACTOR certifies that it will furnish CITY any and all documentation, certification, authorization, license, permit or registration required by the laws or rules and regulations of the City of Bloomington, the State of Indiana and the United States. CONTRACTOR further certifies that it is now and will maintain in good standing with such

governmental agencies and that it will keep its license, permit registration, authorization or certification in force during the term of this Agreement.

5.07. Applicable Laws CONTRACTOR agrees to comply with all federal, state, and local laws, rules and regulations applicable to CONTRACTOR in performing work pursuant to this Agreement, including, but not limited to, discrimination in employment, prevailing wage laws, conflicts of interest, public notice, accounting records and requirements. CONTRACTOR shall comply with City of Bloomington Ordinance 2.21.020 and all other federal, state and local laws and regulations governing non-discrimination, including but not limited to employment. This Agreement shall be governed by the laws of the United States, and the State of Indiana, and by all Municipal Ordinances and Codes of the City of Bloomington. Venue of any disputes arising under this Agreement shall be in the Monroe Circuit Court, Monroe County, Indiana.

5.08. Non-Discrimination

5.08.01 CONTRACTOR and subcontractors shall not discriminate against any employee or applicant for employment, to be employed in the performance of this Agreement, with respect to hire, tenure, terms, training, conditions or privileges of employment, because of race, sex, color, religion, national origin, ancestry, disability, sexual orientation, gender identity, veteran status or housing status. Breach of this covenant may be regarded as a material breach of the Agreement.

5.08.02 CONTRACTOR certifies for itself and all its subcontractors compliance with existing laws of the City of Bloomington, the State of Indiana and the United States regarding:

Prohibition of discrimination in employment practices on the basis of race, sex, color, religion, national origin, ancestry, disability, sexual orientation, gender identity, veteran status, housing status, or any other legally protected classification;

The utilization of Minority and Women Business Enterprises. CONTRACTOR further certifies that it:

- a. Has formulated its own Affirmative Action plan for the recruitment, training and employment of minorities and women, including goals and timetable; which has been approved by the City's Contract Compliance Officer.
- b. Encourages the use of small business, minority-owned business and women-owned business in its operations.

CONTRACTOR understands that the City of Bloomington prohibits its employees from engaging in harassment or discrimination of any kind, including harassing or discriminating against independent contractors doing work for the City. If CONTRACTOR believes that a City employee engaged in such conduct towards CONTRACTOR and/or any of its employees, CONTRACTOR or its employees may file a complaint with the City department head in charge of the CONTRACTOR'S work and/or with the City human resources department or the Bloomington Human Rights Commission. The City takes all complaints of harassment and discrimination seriously and will take appropriate disciplinary action if it finds that any City employee engaged in such prohibited conduct.

5.08.03 FURTHER, PURSUANT TO INDIANA CODE 5-16-6-1, CONTRACTOR AGREES:

A) That in the hiring of employees for the performance of work under this Agreement or any sub agreement hereunder, no contractor, or subcontractor, nor any person acting on behalf of such CONTRACTOR or subcontractor, shall by reason of race, sex, color, religion, national origin, ancestry, or any other legally protected classification, discriminate against any citizen of the State of Indiana who is qualified and available to perform the work to which the employment relates.

B) That no contractor, subcontractor, or any person on their behalf, shall, in any manner, discriminate against or intimidate any employee hired for performance of work under this Agreement on account of race, religion, color, sex, national origin, ancestry, or any other legally protected classification.

C) That there may be deducted from the amount payable to CONTRACTOR, by CITY, under this Agreement, penalty of Five Dollars (\$5.00) for each person for each calendar day during which such person was discriminated against or intimidated in violation of the provisions of this Agreement. Any such person discriminated against retains the right to file a discrimination complaint with the appropriate civil rights agency or court.

D) That this Agreement may be canceled or terminated by CITY and all money due or to become hereunder may be forfeited, for a second or any subsequent violations of the terms or conditions under this section of the Agreement.

5.09. Workmanship and Quality of Materials

5.09.01 CONTRACTOR shall guarantee the work for a period of one (1) year from the date of substantial completion. Failure of any portion of the work within one (1) year due to improper construction, materials of construction, or design may result in a refund to CITY of the purchase price of that portion which failed or may result in the forfeiture of CONTRACTOR'S Performance Bond.

5.09.02 OR EQUAL: Wherever in any of the Agreement Documents an article, material or equipment is defined by describing a proprietary product, or by using the name of a manufacturer or vender, the term "Or Equal" or the term "The Equivalent" if not inserted, shall be implied, and it is done for the express purpose of establishing a basis of durability and efficiency and not for the purpose of limiting completion. Whenever material or equipment is submitted for approval as being equal to that specified, the submittal shall include sufficient information and data to demonstrate that the material or equipment conforms to the Contract requirements. The decision as to whether or not such material or equipment is equal to that specified shall be made by the ENGINEER. The approval by the ENGINEER of alternate

material or equipment as being equivalent to that specified, shall not in any way relieve CONTRACTOR of responsibility for failure of the material or equipment due to faulty design, material, or workmanship, to perform the function required by the Contract Documents. Specifications as determined by other entities within the City of Bloomington such as City Utilities shall only be substituted or changed by their approval which shall be submitted in writing to the ENGINEER.

5.09.03 CITY shall be the sole judge of the sufficiency of workmanship and quality of materials. Disputes shall be resolved by the City Engineer and are not subject to arbitration.

5.10. Safety. CONTRACTOR shall be responsible for the safety of employees at all times and shall provide all equipment necessary to insure their safety. CONTRACTOR shall ensure the enforcement of all applicable safety rules, regulations, ordinances and laws, whether federal, state or local. Contractor's Superintendent of Safety shall make daily inspections upon the arrival and leaving of the site at the close of each workday.

5.10.01 CONTRACTOR is required to comply with IOSHA regulations 29 C.F.R 1926, Subpart P, Excavations for all trenches of at least five (5) feet in depth. All cost for trench safety systems shall be the responsibility of the CONTRACTOR and included in the cost of the principal work with which the safety systems are associated. CONTRACTOR shall sign an affidavit, attached as Attachment B, affirming that CONTRACTOR shall maintain compliance with IOSHA requirements for excavations of at least five (5) in depth.

5.11. Amendments/Changes

5.11.01 Except as provided in Paragraph 5.11.02, this Agreement may be amended only by written instrument signed by both CITY and CONTRACTOR.

5.11.02 Without invalidating the Agreement and without notice to any surety, CITY may, at any time or from time to time, order, in writing, additions, deletions, or revisions in the work. Upon receipt of any such document, CONTRACTOR shall promptly proceed with the work involved, which will be performed under the applicable conditions of the Agreement Documents.

5.11.03 If CONTRACTOR believes that any direction of CITY under paragraph 5.11.02, or any other event or condition, will result in an increase in the Contract time or price, he or she shall file written notice with CITY no later than twenty (20) calendar days after the occurrence of the event giving rise to the claim and stating the general nature of the claim with supporting data. No claim for any adjustment of the Contract time or price will be valid if not submitted in accordance with this Paragraph.

5.11.04 CONTRACTOR shall carry on the work and adhere to the progress schedule during all disputes or disagreements with CITY. No work shall be delayed or postponed pending resolution of any dispute or disagreement except as CONTRACTOR and CITY may otherwise agree in writing.

5.12. Performance Bond and Payment Bond

5.12.01 For contracts in excess of \$100,000, CONTRACTOR shall provide CITY with a Performance Bond and a Payment Bond in the amount of one hundred percent (100%) of the contract amount.

5.12.02 Failure by CONTRACTOR to perform the work in a timely or satisfactory fashion may result in forfeiture of CONTRACTOR'S Performance Bond.

5.12.03 If the surety on any bond furnished by CONTRACTOR becomes a party to supervision, liquidation, or rehabilitation action pursuant Indiana Code 27-9 et seq. or its right to do business in the State of Indiana is terminated, CONTRACTOR shall, within thirty (30) calendar days thereafter, substitute another bond and surety, both of which must be acceptable to CITY.

5.13. Payment of Subcontractors CONTRACTOR shall pay all subcontractors, laborers, material suppliers and those performing services to CONTRACTOR on the project under this Agreement. CITY may, as a condition precedent to any payment hereunder, require CONTRACTOR to submit satisfactory evidence of payments of any and all claims of subcontractors, laborers, material suppliers, and those furnishing services to CONTRACTOR. Upon receipt of a lawful claim, CITY shall withhold money due to CONTRACTOR in a sufficient amount to pay the subcontractors, laborers, material suppliers, and those furnishing services to CONTRACTOR.

5.13.01 The surety of the Payment Bond and Performance Bond may not be released until one (1) year after the Board's final settlement with the CONTRACTOR.

5.14. Written Notice Written notice shall be considered as served when delivered in person or sent by mail to the individual, firm, or corporation, or to the last business address of such known to CONTRACTOR who serves the Notice. Notice shall be sent as follows:

TO CITY:

TO CONTRACTOR:

City of Bloomington	Milestone Contractors, LP
Attn: Matt Smethurst	Aaron Chandler, Director of Estimating
P.O. Box 100 Suite 130	4755 West Arlington Road
Bloomington, Indiana 47402	Bloomington, Indiana 47404

5.15. Severability and Waiver In the event that any clause or provision of this Agreement is held to be invalid by any court of competent jurisdiction, the invalidity of such clause or provision shall not affect any other provision of this Agreement. Failure

of either party to insist on strict compliance with any provision of this Agreement shall not constitute waiver of that party's right to demand later compliance with the same or other provisions of this Agreement.

5.16. Notice to Proceed CONTRACTOR shall not begin the work pursuant to the "Scope of Work" of this Agreement until it receives an official written Notice to Proceed from the City. Contractor shall start active and continuous work on the Agreement within fifteen (15) calendar days after the date of the Notice to Proceed. In no case shall work begin prior to the date of the Notice to Proceed. If a delayed starting date is indicated in the proposal, the fifteen (15) calendar day limitation will be waived. Work day charges will then begin on a date mutually agreed upon, but not later than the delayed starting date specified. In the event that any Agreement is canceled after an award has been made but prior to the issuing of the Notice to Proceed, no reimbursement will be made for any expenses accrued relative to this contract during that period.

5.17. Steel or Foundry Products

5.17.01 To comply with Indiana Code 5-16-8, affecting all contracts for the construction, reconstruction, alteration, repair, improvement or maintenance of public works, the following provision shall be added: If steel or foundry products are to be utilized or supplied in the performance of any contract or subcontract, only domestic steel or foundry products shall be used. Should CITY feel that the cost of domestic steel or foundry products is unreasonable; CITY will notify CONTRACTOR in writing of this fact.

5.17.02 Domestic Steel products are defined as follows:

"Products rolled, formed, shaped, drawn, extruded, forged, cast, fabricated or otherwise similarly processed, or processed by a combination of two (2) or more of such operations, from steel made in the United States by open hearth, basic oxygen, electric furnace, Bessemer or other steel making process."

5.17.03 Domestic Foundry products are defined as follows:

"Products cast from ferrous and nonferrous metals by foundries in the United States."

5.17.04 The United States is defined to include all territory subject to the jurisdiction of the United States.

5.17.05 CITY may not authorize or make any payment to CONTRACTOR unless CITY is satisfied that CONTRACTOR has fully complied with this provision.

5.18. Verification of Employees' Immigration Status

Contractor is required to enroll in and verify the work eligibility status of all newly-hired employees through the E-Verify program. (This is not required if the E-Verify program no longer exists). Contractor shall sign an affidavit, attached as Attachment C, affirming that Contractor does not knowingly employ an unauthorized alien. "Unauthorized alien" is defined at 8 U.S. Code 1324a(h)(3) as a person who is not a U.S. citizen or U.S. national and is not lawfully admitted for permanent residence or authorized to work in the U.S. under 8 U.S. Code Chapter 12 or by the U.S. Attorney General.

Contractor and any of its subcontractors may not knowingly employ or contract with an unauthorized alien, or retain an employee or contract with a person that the Contractor or any of its subcontractors learns is an unauthorized alien. If the City obtains information that the Contractor or any of its subcontractors employs or retains an employee who is an unauthorized alien, the City shall notify the Contractor or its subcontractors of the Agreement violation and require that the violation be remedied within thirty (30) calendar days of the date of notice. If the Contractor or any of its subcontractors verify the work eligibility status of the employee in question through the E-Verify program, there is a rebuttable presumption that the Contractor or its subcontractor did not knowingly employ an unauthorized alien. If the Contractor or its subcontractor fails to remedy the violation within the thirty (30) calendar day period, the City shall terminate the Agreement, unless the City determines that terminating the Agreement would be detrimental to the public interest or public property, in which case the City may allow the Agreement to remain in effect until the City procures a new contractor. If the City terminates the Agreement, the Contractor or its subcontractor is liable to the City for actual damages.

Contractor shall require any subcontractors performing work under this Agreement to certify to the Contractor that, at the time of certification, the subcontractor does not knowingly employ or contract with an unauthorized alien and the subcontractor has enrolled in and is participating in the E-Verify program. Contractor shall maintain on file all subcontractors' certifications throughout the term of this Agreement with the City.

5.19. Drug Testing Plan

In accordance with Indiana Code 4-13-18 as amended, the CONTRACTOR was required to submit with his/her bid a written drug testing policy for a public works project that is estimated to cost \$150,000 or more. Among other things, the law sets forth specific requirements that must be in the plan for a program to test the employees of the CONTRACTOR and Subcontractors for drugs. The successful CONTRACTOR must comply with all provisions of the statute. This contract is subject to cancellation if CONTRACTOR fails to implement its testing program during the term of this contract, fails to provide information regarding this testing at the request of CITY; or provides false information to CITY regarding CONTRACTOR's employee drug testing program. CONTRACTOR shall sign an affidavit, attached as Attachment D, affirming that CONTRACTOR has and shall implement CONTRACTOR'S employee drug testing program throughout the term of this project.

5.20. Living Wage Ordinance (LWO)

Contractors that are considered "covered employers" under City Ordinance 2.28, otherwise known as the "Living Wage Ordinance," or "LWO," are required to pay their covered employees at least a living wage. Currently, the living wage is \$15.29

per hour for covered employees, and up to 15% of that amount, or \$2.29, may be in the form the covered employer's contribution to health insurance available to the covered employee.

Contractor is determined to be a covered employer under the LWO. Contractor shall execute the Living Wage Ordinance Affidavit, attached as Exhibit F; shall abide by the LWO by paying their employees a living wage; and shall post the Living Wage Poster, provided by the City Legal Department, in areas frequented by their covered employees.

IN WITNESS WHEREOF, the parties of this Agreement have hereunto set their hands.

DATE: _____

City of Bloomington
Bloomington Board of Public Works

BY:

BY:

Kyla Cox Deckard, President

Contractor Representative

Elizabeth Karon, Vice President

Printed Name

Jennifer Lloyd, Secretary

Title of Contractor Representative

John Hamilton, Mayor of Bloomington

ATTACHMENT 'A'

"SCOPE OF WORK"

Winslow Resurfacing Project (Walnut to Allendale)

This project shall include, but is not limited to, the milling and resurfacing of asphalt pavement, the installation of sidewalk, curb, ADA compliant ramps, and pavement markings on Winslow Road between Walnut Street and Allendale Drive.

ATTACHMENT 'B'

**BIDDER'S AFFIDAVIT IN COMPLIANCE WITH INDIANA CODE 36-1-12-20 TRENCH SAFETY SYSTEMS;
COST RECOVERY**

STATE OF INDIANA)
) SS:
COUNTY OF MONROE)

AFFIDAVIT

The undersigned, being duly sworn, hereby affirms and says that:

1. The undersigned is the DIRECTOR OF ESTIMATING of
(job title)
MILESTONE CONTRACTORS, LP
(company name)
2. The undersigned is duly authorized and has full authority to execute this Bidder's Affidavit.
3. The company named herein that employs the undersigned:
 - i. has contracted with or seeking to contract with the City of Bloomington to provide services; **OR**
 - ii. is a subcontractor on a contract to provide services to the City of Bloomington.
4. By submission of this Bid and subsequent execution of a Contract, the undersigned Bidder certifies that as successful Bidder (Contractor) all trench excavation done within his/her control (by his/her own forces or by his/her Subcontractors) shall be accomplished in strict adherence with OSHA trench safety standards contained in 29 C.F.R. 1926, Subpart P, including all subsequent revisions or updates to these standards as adopted by the United States Department of Labor.
5. The undersigned Bidder certifies that as successful Bidder (Contractor) he/she has obtained or will obtain identical certification from any proposed Subcontractors that will perform trench excavation prior to award of the subcontracts and that he/she will retain such certifications in a file for a period of not less than three (3) years following final acceptance.
6. The Bidder acknowledges that included in the various items listed in the Schedule of Bid Prices and in the Total Amount of Bid Prices are costs for complying with I.C. 36-1-12-20. The Bidder further identifies the costs to be summarized below*:

	Trench Safety Measure	Units of Measure	Unit Cost	Unit Quantity	Extended Cost
A.	TRENCH BOXES	LS	\$1,500.00	1	\$1,500.00
B.					
C.					
D.					
				Total	\$ 1,500.00

Method of Compliance (Specify) TRENCH BOXES

Date: MARCH 13, 2023

Aaron Chandler
Signature

AARON CHANDLER
Printed Name

STATE OF INDIANA)
) SS:
COUNTY OF MONROE)

Before me, a Notary Public in and for said County and State, personally appeared AARON CHANDLER and acknowledged the execution of the foregoing this 13 day of MARCH, 2023.

My Commission Expires: 12/16/29

Elizabeth Haywood
Signature of Notary Public

County of Residence: MONROE

ELIZABETH HAYWOOD
Printed Name of Notary Public

Commission #: 0738003

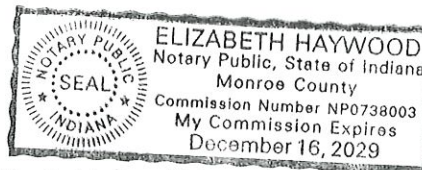

*Bidders: Add extra sheet(s), if needed.

If Bidder fails to complete and execute this sworn affidavit, his/her Bid may be declared nonresponsive and rejected by the **CITY OF BLOOMINGTON**.

ATTACHMENT 'C'

"E-Verify AFFIDAVIT"

STATE OF INDIANA)
)SS:
COUNTY OF MONROE)

E-Verify AFFIDAVIT

The undersigned, being duly sworn, hereby affirms and says that:

- 1. The undersigned is the DIRECTOR OF ESTIMATING of MILESTONE CONTRACTORS, LP.
a. (job title) (company name)
2. The company named herein that employs the undersigned:
i. has contracted with or seeking to contract with the City of Bloomington to provide services; OR
ii. is a subcontractor on a contract to provide services to the City of Bloomington.
3. The undersigned hereby states that, to the best of his/her knowledge and belief, the company named herein does not knowingly employ an "unauthorized alien," as defined at 8 United States Code 1324a(h)(3).
4. The undersigned hereby states that, to the best of his/her belief, the company named herein is enrolled in and participates in the E-verify program.

Signature [Handwritten Signature]

AARON CHANDLER
Printed Name

STATE OF INDIANA)
)SS:
COUNTY OF MONROE)

Before me, a Notary Public in and for said County and State, personally appeared AARON CHANDLER and acknowledged the execution of the foregoing this 13 day of MARCH, 2023.

My Commission Expires: 12/16/29

Elizabeth Haywood
Signature of Notary Public

County of Residence: MONROE

ELIZABETH HAYWOOD
Printed Name of Notary Public

My Commission #: 0738003

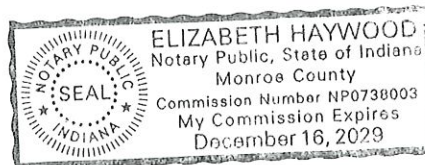

ATTACHMENT 'D'

COMPLIANCE AFFIDAVIT

REGARDING INDIANA CODE CHAPTER 4-13-18

DRUG TESTING OF EMPLOYEES OF PUBLIC WORKS CONTRACTORS

STATE OF INDIANA)

) SS:

COUNTY OF MONROE)

AFFIDAVIT

The undersigned, being duly sworn, hereby affirms and says that:

1. The undersigned is the DIRECTOR OF ESTIMATING of
(job title)
MILESTONE CONTRACTORS, LP
(company name)
2. The undersigned is duly authorized and has full authority to execute this Affidavit.
3. The company named herein that employs the undersigned:
 - iii. has contracted with or seeking to contract with the City of Bloomington to provide services; **OR**
 - iv. is a subcontractor on a contract to provide services to the City of Bloomington.
4. The undersigned certifies that Contractor's submitted written plan for a drug testing program to test employees of the Contractor and Subcontractor for public works projects with an estimated cost of \$150,000 is in accordance with Indiana Code 4-13-18 as amended.
5. The undersigned acknowledges that this Contract shall be subject to cancellation should Contractor fail to comply all provisions of the statute.

Signature

AARON CHANDLER
Printed Name

STATE OF INDIANA)
)SS:
COUNTY OF MONROE)

Before me, a Notary Public in and for said County and State, personally appeared AARON CHANDLER
and acknowledged the execution of the foregoing this 13 day of MARCH, 2023.

My Commission Expires: 12/16/29

Elizabeth Haywood
Signature of Notary Public

County of Residence: MONROE

ELIZABETH HAYWOOD
Printed Name of Notary Public

My Commission #: 0738003

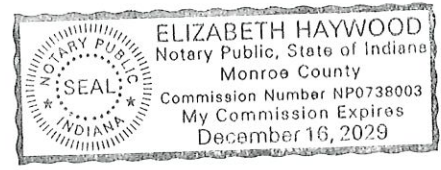

ATTACHMENT 'E'

"Unit Prices"

Project Title : Winslow Resurfacing Project (Walnut to Allendale)

LINE	ITEM	DESCRIPTION	Approximate Quantity and Units	UNITS	UNIT PRICE	BID AMOUNT
001	105-06845	CONSTRUCTION ENGINEERING	1	L.S.	\$4,000.00	\$4,000.00
002	110-01001	MOBILIZATION & DEMOBILIZATION	1	L.S.	\$7,250.00	\$7,250.00
003	201-52370	CLEARING RIGHT OF WAY	1	L.S.	\$5,000.00	\$5,000.00
004	202-02278	CURB, CONCRETE, REMOVE	20	L.F.	\$125.00	\$2,500.00
005	202-02279	CURB AND GUTTER, REMOVE	375	L.F.	\$35.00	\$13,125.00
006	202-52710	SIDEWALK, CONCRETE, REMOVE	300	S.Y.	\$45.00	\$13,500.00
007	205-06933	TEMPORARY INLET PROTECTION	25	EACH	\$200.00	\$5,000.00
008	211-02050	B BORROW	75	C.Y.	\$115.00	\$8,625.00
009	301-12234	COMPACTED AGGREGATE NO. 53	52	C.Y.	\$175.00	\$9,100.00
010	305-12695	LEAN CONCRETE BASE, 9 IN.	130	S.Y.	\$105.00	\$13,650.00
011	306-08034	MILLING, ASPHALT, 1 1/2 IN.	16400	S.Y.	\$3.00	\$49,200.00
012	401-07321	HMA SURFACE, 9.5 mm (TYPE B)	1450	TON	\$105.00	\$152,250.00
013	401-10258	JOINT ADHESIVE, SURFACE	17000	L.F.	\$0.25	\$4,250.00
014	406-05521	ASPHALT FOR TACK COAT	16400	S.Y.	\$0.25	\$4,100.00
015	604-06070	SIDEWALK, CONCRETE 4 IN.	245	S.Y.	\$55.00	\$13,475.00
016	604-08086	CURB RAMP, CONCRETE	130	S.Y.	\$135.00	\$17,550.00
017	604-12083	DETECTABLE WARNING SURFACES	21	S.Y.	\$515.00	\$10,815.00
018	605-06120	CURB, CONCRETE	40	L.F.	\$95.00	\$3,800.00
019	605-06140	CURB AND GUTTER, CONCRETE	385	L.F.	\$55.00	\$21,175.00
020	605-06235	CENTER CURB, D CONCRETE MODIFIED	30	L.F.	\$205.00	\$6,150.00
021	621-06560	MULCHED SEEDING, U	550	S.Y.	\$5.00	\$2,750.00
022	621-06570	TOPSOIL	45	C.Y.	\$315.00	\$14,175.00
023	715-05149	PIPE, TYPE 2, CIRCULAR, 12 IN.	19	L.F.	\$175.00	\$3,325.00
024	720-44025	CASTING, 4, FURNISH/ADJUST TO GRADE	2	EACH	\$1,105.00	\$2,210.00
025	720-45030	INLET, E7	1	EACH	\$2,900.00	\$2,900.00
026	801-06775	MAINTAINING TRAFFIC	1	L.S.	\$32,000.00	\$32,000.00
027	802-05702	SIGN POST, SQUARE TYPE 2, REINFORCED ANCHOR BASE	18	L.F.	\$35.00	\$630.00

CONTINUED TO NEXT PAGE



City of Bloomington
Engineering Department

Letting Date: March 13th, 2023

Proposal Schedule of Items (Unit Prices) Attachment 'E'

Page 2 of 2

Project Title : Winslow Resurfacing Project (Walnut to Allendale)

LINE	ITEM	DESCRIPTION	Approximate Quantity and Units	UNITS	UNIT PRICE	BID AMOUNT
028	804-11921	DELINEATOR POST FLEXIBLE, TYPE II	2	EACH	\$205.00	\$410.00
029	808-03439	TRANSVERSE MARKING, THERMOPLASTIC, CROSSWALK LINE, WHITE, 24 IN.	860	L.F.	\$15.00	\$12,900.00
030	808-75278	TRANSVERSE MARKING, THERMOPLASTIC, CROSSHATCH LINE, YELLOW, 12 IN.	265	L.F.	\$8.55	\$2,265.75
031	808-06703	LINE, THERMOPLASTIC, SOLID, WHITE, 4 IN.	5850	L.F.	\$1.25	\$7,312.50
032	808-75245	LINE, THERMOPLASTIC, SOLID, YELLOW, 4 IN.	9100	L.F.	\$1.25	\$11,375.00
033	808-75297	TRANSVERSE MARKING, THERMOPLASTIC, STOP LINE, 24 IN.	125	L.F.	\$15.00	\$1,875.00
034	808-75300	TRANSVERSE MARKING, THERMOPLASTIC, CROSSWALK LINE, WHITE, 6 IN.	125	L.F.	\$3.55	\$443.75
035	808-75320	PAVEMENT MESSAGE MARKING, THERMOPLASTIC LANE INDICATION ARROW	10	EACH	\$145.00	\$1,450.00
036	808-75998	SNOWPLOWABLE RAISED PAVEMENT MARKER	63	EACH	\$225.00	\$14,175.00
TOTAL PROJECT BID:						\$474,712.00

Bidder acknowledges that:

- each Bid Unit Price includes an amount considered by Bidder to be adequate to cover Contractor's overhead and profit for each separately identified item, and
- estimated quantities are not guaranteed, and are solely for the purpose of comparison of Bids, and final payment for all Unit Price Work will be based on actual quantities, determined as provided in the Contract Documents.

EXHIBIT F

AFFIDAVIT THE LIVING WAGE ORDINANCE

The undersigned, being duly sworn, hereby affirms and says that:

1. The undersigned is the _____ of Milestone Contractors, LP
(job title) (company name)
2. The company named herein that employs the undersigned has contracted with or is seeking to contract with the City of Bloomington to provide services.
3. The undersigned hereby states that, to the best of their knowledge and belief, the company named herein is subject to Bloomington City Ordinance 2.28, otherwise known as the "Living Wage Ordinance."
4. The projected employment needs under the award include the following: [Click here to enter text.](#)
5. The projected net increase or decrease in jobs for covered employees by job title that will result from awarding the assistance: [Click here to enter text.](#)
6. The undersigned hereby affirms that the smallest hourly wage to be earned by each of their covered employees shall be at least the living wage.

I affirm under the penalties of perjury that the foregoing facts and information are true and correct to the best of my knowledge and belief.

Signature

Printed name

STATE OF INDIANA)
) SS:
COUNTY OF _____)

Before me, a Notary Public in and for said County and State, personally appeared _____
_____ and acknowledged the execution of the foregoing this _____ day of _____
_____, 2022.

My Commission Expires: _____

Notary Public

County of Residence: _____

Name Printed

Commission Number

City of Bloomington
 Redevelopment Commission
 Project Review & Approval Form

Please Note:

- Approval of the project by the Redevelopment Commission through this Project Review & Approval Form does not represent an authorization to begin work or expend funds.
- Authorization of work and the commitment of funds shall be done when the Redevelopment Commission reviews and approves: (1) a Purchase Order or Contract prepared after complying with the appropriate procurement process for the type of item, service or construction being sought and (2) the estimated costs associated with the Purchase Order or Contract.
- No payment of funds shall be made without a duly authorized and approved Purchase Order or Contract. All claims for payment against a duly authorized Purchase Order or Contract shall be submitted to the Redevelopment Commission for their review and approval along with any required departmental inspections, reviews and approvals prior to the payment of any funds.

To Be Completed by Requesting Party:

Project Name: Winslow Road Resurfacing

Project Manager: Adam Wason

Project Description: This project will resurface and improve East Winslow Road between South Walnut Street and High Street. This will project is anticipated to be part of the INDOT Community Crossing Grant.

Project Timeline:

Start Date: Fall 2022

End Date: December 2023

Financial Information:

Estimated full cost of project:	\$500,000 \$474,712.00
Sources of funds:	
INDOT Community Crossing Grant	\$237,356
Consolidated TIF	\$500,000 \$237,356

Project Phases: This breakdown should mirror the contract(s) expected to be issued for this project. Each phase should include a description of the work to be performed, the cost, and the timeline for the contract.

Step	Description	Estimated Cost	Timeline
1	Preliminary Engineering	-	2022-Spring 2023
2	Construction - Milestone	\$474,712.00	2023

TIF District: Consolidated TIF (Walnut-Winslow)

Resolution History: 22-60 Project Review and Approval Form
23-27 Local Match Funding Approval

To Be Completed by Redevelopment Commission Staff:

Approved on _____

By Resolution _____ by a vote of _____

23-28
RESOLUTION
OF THE
REDEVELOPMENT COMMISSION
OF THE
CITY OF BLOOMINGTON, INDIANA

APPROVAL OF FUNDING FOR CONSTRUCTION OF GRIFFY DAM CROSSING PROJECT

- WHEREAS, pursuant to Indiana Code § 36-7-14 *et seq.*, the Redevelopment Commission of the City of Bloomington (“RDC”) and the Common Council of the City of Bloomington created economic development areas known as the Consolidated Economic Development Area (“Consolidated TIF”) and the North Kinser Pike and Prow Road Economic Development Area (“North Kinser Pike TIF”), the purpose of which is to facilitate economic development and revitalization in Bloomington; and
- WHEREAS, the Consolidated TIF and North Kinser Pike TIF (“TIFs”) are allocation areas for purposes of tax increment financing; and
- WHEREAS, tax increment may be used—among other things—to pay expenses incurred by the RDC for local public improvements that are in the TIFs or that serve the TIFs; and
- WHEREAS, Griffy Lake and the surrounding trails serve the TIFs by providing the only lake within City limits, are a key attraction for allocation area residents, improve the quality of place for the TIFs, and enhance the overall economic development potential for the allocation areas; and
- WHEREAS, in Resolution 22-63 the RDC approved an project review and approval form (“Form”) for a project that would complete trail safety and access improvements to the Griffy Loop Trail and connect existing trails to the new safer crossing (“Project”); and
- WHEREAS, the RDC approved funding for design and construction administration services for Mader Design in Resolution 22-67; and
- WHEREAS, City staff received two responsive bids and selected Scenic Construction Services, Inc. as the lowest responsive and responsible bidder of construction services (“Services”);
- WHEREAS, staff have negotiated an agreement with Scenic Construction to provide the Services for an amount not to exceed \$344,700.00, which is attached to this Resolution as Exhibit A, (“Agreement”); and
- WHEREAS, the Board of Parks Commissioners is scheduled to consider the Agreement for approval at its meeting on Tuesday, March 28, 2023;
- WHEREAS, the RDC has sufficient funds in both the Consolidated and North Kinser Pike TIFs to cover the Services; and
- WHEREAS, the City has brought the RDC a Project Review and Approval Form for the Project, which is attached to this Resolution as Exhibit B.

NOW, THEREFORE, BE IT RESOLVED BY THE REDEVELOPMENT COMMISSION OF THE CITY OF BLOOMINGTON, INDIANA, THAT:

1. The RDC finds that the Project is an appropriate use of the TIFs, it serves the public's interest, and reaffirms its support of the Project, as set forth in the Project Review and Approval Form.
2. The RDC hereby approves of the Agreement with Scenic Construction Services, Inc. and funding for construction services for the Project in an amount not to exceed Three Hundred Forty-Four Thousand Seven Hundred Dollars (\$344,700.00) from either the Consolidated or North Kinser Pike TIF pursuant to the terms of the Agreement in Exhibit A. For the avoidance of doubt, the terms of Exhibit A do not remove the requirement to comply with the City's claims process.
3. The funding authorizations contained in this Resolution shall terminate on December 31, 2023, unless extended by the RDC in advance.
4. All approvals and authorizations in this Resolution are contingent upon the Board of Parks Commissioners' approval of the Agreement. In the event that the Agreement is not approved by that board, the approvals in this resolution shall be null and automatically terminate.

BLOOMINGTON REDEVELOPMENT COMMISSION

Cindy Kinnarney, President

ATTEST:

Deborah Myerson, Secretary

Date

AGREEMENT

BETWEEN

CITY OF BLOOMINGTON

PARKS AND RECREATION DEPARTMENT

AND

SCENIC CONSTRUCTION SERVICES, INC.

FOR

GRIFFY DAM TRAIL CROSSING CONSTRUCTION

THIS AGREEMENT, executed by and between the City of Bloomington, Indiana, Parks and Recreation Department through the Board of Park Commissioners (hereinafter CITY), and Scenic Construction Services, Inc. (hereinafter CONTRACTOR);

WITNESSETH THAT:

HEREAS, CITY desires to retain CONTRACTOR'S services for **SCOPE OF WORK** (more particularly described in Attachment A, "Scope of Work"; and

WHEREAS, CONTRACTOR is capable of performing work as per his/her Bid on the Bid Summary sheet; and

WHEREAS, in accordance with Indiana Code 5-16-13 *et seq.*, incorporated herein by reference, Contractor is a Tier 1 or General Contractor for this project; and

WHEREAS, CONTRACTOR was determined to be the lowest responsible and responsive Bidder for said project.

NOW, THEREFORE, in consideration of the mutual promises hereinafter enumerated, the parties agree as follows:

ARTICLE 1. TERM

1.01 This Agreement shall be in effect upon execution of this Agreement by all parties. In accordance with Indiana Code 5-16-13 *et seq.*, incorporated herein by reference, Contractor is a Tier 1 contractor or general contractor for this project.

ARTICLE 2. SERVICES

2.01 CONTRACTOR shall complete all work required under this Agreement within 135 calendar days from the date of the Notice to Proceed, unless the parties mutually agree to a later completion date. Substantial Completion shall mean completion of all work.

2.02 It is hereby understood by both parties that time is of the essence in this Agreement. Failure of CONTRACTOR to complete all work as herein provided will result in monetary damages to CITY. It is hereby agreed that CITY will be damaged for every day the work has not been performed in the manner herein provided and that the measure of those damages shall be determined by reference Section 13.00 of the General Conditions for Each Day of Overrun in Contract Time. CONTRACTOR agrees to pay CITY said damages or, in the alternative, CITY, at its sole discretion, may withhold monies otherwise due CONTRACTOR. It is expressly understood by the parties hereto that these damages relate to the time of performance and do not limit CITY's other remedies under this Agreement, or as provided by applicable law, for other damages.

2.03 CONTRACTOR agrees that no charges or claims for damages shall be made by him for any delays or hindrances, from any cause whatsoever during the progress of any portion of the services specified in the Agreement. Such delays or hindrances, if any, may be compensated for by an extension of time for a reasonable period as may be mutually agreed upon between the parties, it being understood, however, that permitting CONTRACTOR to proceed to complete any service, or any part of the services / project, after the date to which the time of completion may have been extended, shall in no way operate as a waiver on the part of CITY of any of its rights herein.

ARTICLE 3. COMPENSATION

3.01 CONTRACTOR shall provide services as specified in Attachment A, "Scope of Work", attached hereto and incorporated into this Agreement.

3.02 Upon the submittal of approved claims, CITY shall compensate CONTRACTOR in a lump sum not to exceed three hundred forty four thousand seven hundred dollars (\$344,700). CITY may withhold payment, in whole or in part, to the extent necessary to protect itself from a loss on account of any of the following:

Defective work.

Evidence indicating the probable filing of claims by other parties against CONTRACTOR which may adversely affect CITY.

Failure of CONTRACTOR to make payments due to subcontractors, material suppliers or employees.

Damage to CITY or a third party.

3.03 The submission of any request for payment shall be deemed a waiver and release by CONTRACTOR of all liens and claims with respect to the work and period to which such payment request pertains except as specifically reserved and noted on such request.

3.04 CONTRACTOR shall maintain proper account records for the scope of all services of this Agreement and provide an accounting for all charges and expenditures as may be necessary for audit purposes. All such records shall be subject to inspection and examination by CITY's representatives at reasonable business hours.

3.05 For projects utilizing federal funding the CONTRACTOR shall submit time sheets (WH-347) for his own and all subcontracted employees, to City Engineer or his representative for approval and review, including review for compliance with Davis Bacon requirements, if federal funds are used.

3.06 **Engineer** The Parks and Recreation Department Operations Director shall act as the CITY's representative and assume all duties and responsibilities and have all the rights and authority assigned to the Engineer in the Contract Documents in connection with completion of the Work in accordance with the Contract Documents.

ARTICLE 4. RETAINAGE

For contracts in excess of \$100,000 and for which Contractor requested Progressive Payments on its Bid Form, the Owner requires that retainage be held set out below.

4.01 **Escrow Agent** The retainage amount withheld shall be placed in an escrow account. First Financial Bank, Bloomington, Indiana, shall serve as the escrow agent.

4.02 **Retainage Amount** The escrow agent, Owner and Contractor shall enter into a written escrow agreement. Under that agreement, the Owner shall withhold five percent (5%) of the dollar value of all work satisfactorily completed until the Contract work is complete. The escrow agent shall invest all escrowed principal in obligations selected by the escrow agent. The escrow agent shall be compensated for the agent's services by a reasonable fee, agreed upon by the parties, that is comparable with fees charged for the handling of escrow accounts of similar size and duration. The fee shall be paid from the escrow income. The escrow agent's fee may be determined by specifying an amount of interest the escrow agent will pay on the escrowed amount, with any additional earned interest serving as the escrow agent's fee. The escrow agreement may include other terms and conditions as deemed necessary by the parties. However, if Contractor intends to receive a Single Lump Sum payment upon acceptance of this project, retainage will not be required and an Escrow Agreement will not be required.

4.03 **Payment of Escrow Amount** The escrow agent shall hold the escrowed principal and income until receipt of the notice from the Owner and Contractor that the Contract work has been substantially completed to the reasonable satisfaction of the Owner, at which time the Owner shall pay to the Contractor the balance to be paid under this Contract and execute such documents as are necessary to authorize the escrow agent to pay to the Contractor the funds in the escrow account, including both specifying the part of the escrowed principal to be released from the escrow and the person to whom that portion is to be released. After receipt of the notice, the escrow agent shall remit the designated part of the escrowed principal and the escrowed income, minus the escrow agent's fees, to the person specified in the notice. However, nothing in this section shall prohibit Owner from requiring the escrow agent to withhold amounts necessary to complete minor items of the Contract, following substantial completion of the Contract in accordance with the provisions of paragraph 4.04.

4.04 **Withholding Funds for Completion of Contract** If, upon substantial completion of the Contract, there still remains minor Contract work that needs to be completed, or minor Contract work that needs to be performed to the satisfaction of the Owner, Owner may direct the escrow agent to retain in the escrow account, and withhold from payment to the Contractor, an amount equal to two hundred percent (200%) of the value of said work. The value of said work shall be determined by the architect/engineer. The escrow agent shall release the funds withheld under this section after receipt of notice from the Owner that all work on the Contract has been satisfactorily completed. In the event that said work is not

completed by the Contractor, but by Owner or another party under contract with the Owner, said funds shall be released to the Owner.

ARTICLE 5. GENERAL PROVISIONS

5.01 CONTRACTOR agrees to indemnify and hold harmless CITY and its officers, agents, officials and employees for any and all claims, actions, causes of action, judgments and liens arising out of any negligent act or omission by CONTRACTOR or any of its officers, agents, officials, employees, or subcontractors or any defect in materials or workmanship of any supply, materials, mechanism or other product or service which it or any of its officers, agents, officials, employees, or subcontractors has supplied to CITY or has used in connection with this Agreement and regardless of whether or not it is caused in part by a party indemnified herein under. Such indemnity shall include attorney's fees and all costs and other expenses arising there from or incurred in connection therewith and shall not be limited by reason of the enumeration of any insurance coverage required herein.

CONTRACTOR shall indemnify and hold harmless CITY and its officers, agents, officials and employees for any and all damages, actions, costs, (including, but not limited to, attorney's fees, court costs and costs of investigation) judgments and claims by anyone for damage to property, injury or death to persons resulting from the collapse or failure of any trenches, ditches or other excavations constructed under or associated with this contract.

5.02 Abandonment, Default and Termination

5.02.01 CITY shall have the right to abandon the work contracted for in this Agreement without penalty. If CITY abandons the work described herein, CONTRACTOR shall deliver to CITY all surveys, notes, drawings, specifications and estimates completed or partially completed and these shall become the property of CITY. The earned value of the work performed shall be based upon an estimate of the proportion between the work performed by CONTRACTOR under this Agreement and the work which CONTRACTOR was obligated to perform under this Agreement. This proportion shall be mutually agreed upon by CITY and CONTRACTOR. The payment made to CONTRACTOR shall be paid as a final payment in full settlement of his services hereunder.

5.02.02 If CONTRACTOR defaults or fails to fulfill in a timely and proper manner the obligations pursuant to this Agreement, CITY may, after seven (7) days' written notice has been delivered to CONTRACTOR, and without prejudice to any other remedy it may have, make good such deficiencies and may deduct the cost thereof from the payment then or thereafter due to CONTRACTOR. In the alternative, CITY, at its option, may terminate this Agreement and take possession of the site and of all materials, equipment, tools and construction equipment and machinery thereon owned by CONTRACTOR, and may finish the project by whatever method it may deem expedient, and if the such action exceeds the unpaid balance of the sum amount, CONTRACTOR or his surety, shall pay the difference to CITY.

5.02.03 Default: If CONTRACTOR breaches this Agreement or fails to perform the work in an acceptable manner, he shall be considered in default. Any one or more of the following will be considered a default:

Failure to begin the work under this Agreement within the time specified.

Failure to perform the work with sufficient supervision, workmen, equipment and materials to insure prompt completion of said work within the time limits allowed.

Unsuitable performance of the work as determined by CITY ENGINEER or his representative.

Neglecting or refusing to remove defective materials or failure to perform anew such work as shall have been rejected.

Discontinuing the prosecution of the work or any part of it.

Inability to finance the work adequately.

If, for any other reason, CONTRACTOR breaches this Agreement or fails to carry on the work in an acceptable manner.

5.02.04 CITY shall send CONTRACTOR a written notice of default. If CONTRACTOR, or his Surety, within a period of ten (10) days after such notice, fails to remedy the default, then CITY shall have full power and authority, without violation of the Contract, to take the prosecution of the work out of the hands of said CONTRACTOR, to appropriate or use any or all materials and equipment on the ground as may be suitable and acceptable, and may, at its option, turn the work over to the Surety, or enter into an agreement with another Contractor for the completion of the Agreement according to the terms and provisions thereof, or CITY may use such other methods as, in its opinion, shall be required for the completion of said Contract in an acceptable manner.

5.02.05 All cost of completing the work under the Contract shall be deducted from the monies due or which may become due to said CONTRACTOR. In case the expenses so incurred by CITY shall be less than the sum which would have been payable under the Contract if it had been completed by said CONTRACTOR, CONTRACTOR shall be entitled to receive the difference. However, in case such expense shall exceed the sum which would have been payable under the Contract, CONTRACTOR and his Surety will be liable and shall pay to CITY the amount of said excess. By taking over the prosecution of the work, CITY does not forfeit the right to recover damages from CONTRACTOR or his Surety for his failure to complete the work in the time specified.

5.02.06 Notwithstanding any other provision of this Agreement, if funds for the continued fulfillment of the Agreement by CITY are at any time not forthcoming or are insufficient, through failure of any entity to appropriate the funds or otherwise, then CITY shall have the right to terminate this Agreement without penalty by giving prior written notice documenting the lack of funding in which instance, unless otherwise agreed to by the parties, this Agreement shall terminate and become null and void.

5.02.07 CITY agrees that it will make its best effort to obtain sufficient funds, including but not limited to, including in its budget for each fiscal period during the term hereof a request for sufficient funds to meet its obligations hereunder in full.

5.03 Successors and Assigns

5.03.01 Both parties agree that for the purpose of this Agreement, CONTRACTOR shall be an Independent Contractor and not an employee of CITY.

5.03.02 No portion of this Agreement shall be sublet, assigned, transferred or otherwise disposed of by CONTRACTOR except with the written consent of CITY being first obtained. Consent to sublet, assign, transfer, or otherwise dispose of any portion of this Agreement shall not be construed to relieve CONTRACTOR of any responsibility of the fulfillment of this Agreement.

5.04 Extent of Agreement: Integration

5.04.01 This Agreement consists of the following parts, each of which is as fully a part of this Agreement as if set out herein:

1. This Agreement and its Attachments.
2. All Written Amendments and other documents amending, modifying, or supplementing the Contract Documents which may be delivered or issued after the Effective Date of the Agreement and are not attached hereto.
3. All Addenda to the Bid Documents.
4. The Invitation to Bidders.
5. The Instructions to Bidders.
6. The Special Conditions.
7. All plans and technical specifications as provided for the work that is to be completed.
8. The Supplementary Conditions.
9. The General Conditions.
10. The General and Technical Specifications.
11. CONTRACTOR'S submittals.
12. The Performance Bond and the Payment Bond.
13. The Escrow Agreement.
14. Request for Taxpayer Identification number and certification: Substitute W-9.

5.04.02 In resolving conflicts, errors, discrepancies and disputes concerning the Scope of Work to be performed by CONTRACTOR, and other rights and obligations of CITY and CONTRACTOR, the document expressing the greater quantity, quality or other scope of work in question, or imposing the greater obligation upon CONTRACTOR and affording the greater right or remedy to CITY shall govern; otherwise the documents shall be given precedence in the order as enumerated above.

5.05 Insurance

5.05.01

CONTRACTOR shall, as a prerequisite to this Agreement, purchase and thereafter maintain such insurance as will protect him from the claims set forth below which may arise out of or result from CONTRACTOR'S operations under this Agreement, whether such operations be by CONTRACTOR or by any SUBCONTRACTORS or by anyone directly or indirectly employed by any of them, or by anyone for whose acts any of them may be liable:

Coverage

Limits

A.	Worker’s Compensation & Disability	Statutory Requirements
B.	Employer’s Liability Bodily Injury by Accident	\$100,000 each accident
	Bodily Injury by Disease	\$500,000 policy limit
	Bodily Injury by Disease	\$100,000 each employee
C.	Commercial General Liability (Occurrence Basis)	\$1,000,000 per occurrence
	Bodily Injury, personal injury, property damage, contractual liability, products-completed operations, General Aggregate Limit (other than Products/Completed Operations)	and \$2,000,000 in the aggregate
	Products/Completed Operation	\$1,000,000
	Personal & Advertising Injury Limit	\$1,000,000
	Each Occurrence Limit	\$1,000,000
	Fire Damage (any one fire)	\$50,000
D.	Comprehensive Auto Liability (single limit, owned, hired and non-owned)	\$1,000,000 each accident
	Bodily injury and property damage	
E.	Umbrella Excess Liability	\$5,000,000 each occurrence and aggregate
	The Deductible on the Umbrella Liability shall not be more than	\$10,000

5.05.02 CONTRACTOR’S comprehensive general liability insurance shall also provide coverage for the following:

Premises and operations;

Contractual liability insurance as applicable to any hold-harmless agreements;

Completed operations and products; which also must be maintained for a minimum period of two (2) years after final payment and CONTRACTOR shall continue to provide evidence of such coverage to CITY on an annual basis during the aforementioned period;

Broad form property damage - including completed operations;

Fellow employee claims under Personal Injury; and

Independent Contractors.

5.05.03 With the prior written approval of CITY, CONTRACTOR may substitute different types or amounts of coverage for those specified as long as the total amount of required protection is not reduced.

5.05.04 Certificates of Insurance showing such coverage then in force (but not less than the amount shown above) shall be on file with CITY prior to commencement of work. These Certificates shall contain a provision that coverage afforded under the policies will not be canceled or non-renewed until at least sixty (60) days’ prior written notice has been received by CITY. The CITY shall be named as an additional insured on the Commercial General Liability, Automobile Liability, and Umbrella Excess Liability policies. The CONTRACTOR shall agree to a waiver of subrogation on its Worker’s Compensation policy.

5.06 **Necessary Documentation** CONTRACTOR certifies that it will furnish CITY any and all documentation, certification, authorization, license, permit or registration required by the laws or rules and regulations of the City of Bloomington, the State of Indiana and the United States. CONTRACTOR further certifies that it is now and will maintain in good standing with such governmental agencies and that it will keep its license, permit registration, authorization or certification in force during the term of this Agreement.

5.07 **Applicable Laws** CONTRACTOR agrees to comply with all federal, state, and local laws, rules and regulations applicable to CONTRACTOR in performing work pursuant to this Agreement, including, but not limited to, discrimination in employment, prevailing wage laws, conflicts of interest, public notice, accounting records and requirements. This Agreement

shall be governed by the laws of the United States, and the State of Indiana, and by all Municipal Ordinances and Codes of the City of Bloomington. Venue of any disputes arising under this Agreement shall be in the Monroe Circuit Court, Monroe County, Indiana.

5.08 Non-Discrimination

5.08.01 CONTRACTOR and subcontractors shall not discriminate against any employee or applicant for employment, to be employed in the performance of this Agreement, with respect to hire, tenure, terms, training, conditions or privileges of employment, because of race, sex, color, religion, national origin, ancestry, disability, sexual orientation, gender identity, veteran status or housing status. Breach of this covenant may be regarded as a material breach of the Agreement.

5.08.02 CONTRACTOR certifies for itself and all its subcontractors compliance with existing laws of the City of Bloomington, the State of Indiana and the United States regarding:

Prohibition of discrimination in employment practices on the basis of race, sex, color, religion, national origin, ancestry, disability, sexual orientation, gender identity, veteran status, housing status, or any other legally protected classification;

The utilization of Minority and Women Business Enterprises. CONTRACTOR further certifies that it:

a. Has formulated its own Affirmation Action plan for the recruitment, training and employment of minorities and women, including goals and timetable; which has been approved by the City's Contract Compliance Officer.

b. Encourages the use of small business, minority-owned business and women-owned business in its operations.

5.08.03 FURTHER, PURSUANT TO INDIANA CODE 5-16-6-1, CONTRACTOR AGREES:

A) That in the hiring of employees for the performance of work under this Agreement or any sub agreement hereunder, no contractor, or subcontractor, nor any person acting on behalf of such CONTRACTOR or subcontractor, shall by reason of race, sex, color, religion, national origin, ancestry, or any other legally protected classification, discriminate against any citizen of the State of Indiana who is qualified and available to perform the work to which the employment relates.

B) That no contractor, subcontractor, or any person on their behalf, shall, in any manner, discriminate against or intimidate any employee hired for performance of work under this Agreement on account of race, religion, color, sex, national origin, ancestry, or any other legally protected classification.

C) That there may be deducted from the amount payable to CONTRACTOR, by CITY, under this Agreement, penalty of Five Dollars (\$5.00) for each person for each calendar day during which such person was discriminated against or intimidated in violation of the provisions of this Agreement. Any such person discriminated against retains the right to file a discrimination complaint with the appropriate civil rights agency or court.

D) That this Agreement may be canceled or terminated by CITY and all money due or to become hereunder may be forfeited, for a second or any subsequent violations of the terms or conditions under this section of the Agreement.

5.09 Workmanship and Quality of Materials

5.09.01 CONTRACTOR shall guarantee the work for a period of one (1) year from the date of substantial completion. Failure of any portion of the work within one (1) year due to improper construction, materials of construction, or design may result in a refund to CITY of the purchase price of that portion which failed or may result in the forfeiture of CONTRACTOR's Performance Bond.

5.09.02 SUBSTITUTION: Whenever material or equipment is submitted for approval as being equal to that specified, the submittal shall include sufficient information and data to demonstrate that the material or equipment conforms to the Contract requirements. The decision as to whether or not such material or equipment is equal to that specified shall be made by the ENGINEER. The approval by the ENGINEER of alternate material or equipment as being equivalent to that specified, shall not in any way relieve CONTRACTOR of responsibility for failure of the material or equipment due to faulty design, material, or workmanship, to perform the function required by the Contract Documents. Specifications as determined by other entities within the City of Bloomington such as City Utilities shall only be substituted or changed by their approval which shall be submitted in writing to the ENGINEER.

5.09.03 CITY shall be the sole judge of the sufficiency of workmanship and quality of materials. Disputes shall be resolved by the City Engineer and are not subject to arbitration.

5.10 Safety. CONTRACTOR shall be responsible for the safety of employees at all times and shall provide all equipment necessary to insure their safety. CONTRACTOR shall ensure the enforcement of all applicable safety rules, regulations, ordinances and laws, whether federal, state or local. Contractor's Superintendent of Safety shall make daily inspections upon the arrival and leaving of the site at the close of each workday.

5.10.01 CONTRACTOR is required to comply with IOSHA regulations 29 C.F.R 1926, Subpart P, Excavations for all trenches of at least five (5) feet in depth. All cost for trench safety systems shall be the responsibility of the CONTRACTOR and included in the cost of the principal work with which the safety systems are associated. CONTRACTOR shall sign an affidavit, attached as Attachment B, affirming that CONTRACTOR shall maintain compliance with IOSHA requirements for excavations of at least five (5) in depth.

5.11 Amendments/Changes

5.11.01 Except as provided in Paragraph 5.11.02, this Agreement may be amended only by written instrument signed by both CITY and CONTRACTOR.

5.11.02 Without invalidating the Agreement and without notice to any surety, CITY may, at any time or from time to time, order, in writing, additions, deletions, or revisions in the work. Upon receipt of any such document, CONTRACTOR shall promptly proceed with the work involved, which will be performed under the applicable conditions of the Agreement Documents.

5.11.03 If CONTRACTOR believes that any direction of CITY under paragraph 5.11.02, or any other event or condition, will result in an increase in the Contract time or price, he shall file written notice with CITY no later than twenty (20) calendar days after the occurrence of the event giving rise to the claim and stating the general nature of the claim with supporting data. No claim for any adjustment of the Contract time or price will be valid if not submitted in accordance with this Paragraph.

5.11.04 CONTRACTOR shall carry on the work and adhere to the progress schedule during all disputes or disagreements with CITY. No work shall be delayed or postponed pending resolution of any dispute or disagreement except as CONTRACTOR and CITY may otherwise agree in writing.

5.12 Performance Bond and Payment Bond

5.12.01 For contracts in excess of \$100,000, CONTRACTOR shall provide CITY with a Performance Bond and a Payment Bond in the amount of one hundred percent (100%) of the contract amount.

5.12.02 Failure by CONTRACTOR to perform the work in a timely or satisfactory fashion may result in forfeiture of CONTRACTOR'S Performance Bond.

5.12.03 If the surety on any bond furnished by CONTRACTOR becomes a party to supervision, liquidation, or rehabilitation action pursuant Indiana Code 27-9 et seq. or its right to do business in the State of Indiana is terminated, CONTRACTOR shall, within thirty (30) calendar days thereafter, substitute another bond and surety, both of which must be acceptable to CITY.

5.13 Payment of Subcontractors CONTRACTOR shall pay all subcontractors, laborers, material suppliers and those performing services to CONTRACTOR on the project under this Agreement. CITY may, as a condition precedent to any payment hereunder, require CONTRACTOR to submit satisfactory evidence of payments of any and all claims of subcontractors, laborers, material suppliers, and those furnishing services to CONTRACTOR. Upon receipt of a lawful claim, CITY shall withhold money due to CONTRACTOR in a sufficient amount to pay the subcontractors, laborers, material suppliers, and those furnishing services to CONTRACTOR.

5.13.01 The surety of the Payment Bond may not be released until one (1) year after the CITY's final settlement with the CONTRACTOR.

5.14 Written Notice Written notice shall be considered as served when delivered in person or sent by mail to the individual, firm, or corporation, or to the last business address of such known to CONTRACTOR who serves the Notice. Notice shall be sent as follows:

TO CITY:

TO CONTRACTOR:

City of Bloomington	Scenic Construction Services, Inc.
Attn: Tim Street, Operations Director	Attn: Tony Biasi
401 N. Morton St., Suite 250	1037 Hawthorn Bloom Drive
Bloomington, Indiana 47404	New Whiteland, IN 46184

5.15 Severability and Waiver In the event that any clause or provision of this Agreement is held to be invalid by any court of competent jurisdiction, the invalidity of such clause or provision shall not affect any other provision of this Agreement. Failure of either party to insist on strict compliance with any provision of this Agreement shall not constitute waiver of that party’s right to demand later compliance with the same or other provisions of this Agreement.

5.16 Notice to Proceed CONTRACTOR shall not begin the work pursuant to the “Scope of Work” of this Agreement until it receives an official written Notice to Proceed from the City. Contractor shall start active and continuous work on the Agreement within fifteen (15) calendar days after the date of the Notice to Proceed. In no case shall work begin prior to the date of the Notice to Proceed. If a delayed starting date is indicated in the proposal, the fifteen (15) calendar day limitation will be waived. Work day charges will then begin on a date mutually agreed upon, but not later than the delayed starting date specified. In the event that any Agreement is canceled after an award has been made but prior to the issuing of the Notice to Proceed, no reimbursement will be made for any expenses accrued relative to this contract during that period.

5.17 Steel or Foundry Products

5.17.01 To comply with Indiana Code 5-16-8, affecting all contracts for the construction, reconstruction, alteration, repair, improvement or maintenance of public works, the following provision shall be added: If steel or foundry products are to be utilized or supplied in the performance of any contract or subcontract, only domestic steel or foundry products shall be used. Should CITY feel that the cost of domestic steel or foundry products is unreasonable; CITY will notify CONTRACTOR in writing of this fact.

5.17.02 Domestic Steel products are defined as follows:

“Products rolled, formed, shaped, drawn, extruded, forged, cast, fabricated or otherwise similarly processed, or processed by a combination of two (2) or more of such operations, from steel made in the United States by open hearth, basic oxygen, electric furnace, Bessemer or other steel making process.”

5.17.03 Domestic Foundry products are defined as follows:

“Products cast from ferrous and nonferrous metals by foundries in the United States.”

5.17.04 The United States is defined to include all territory subject to the jurisdiction of the United States.

5.17.05 CITY may not authorize or make any payment to CONTRACTOR unless CITY is satisfied that CONTRACTOR has fully complied with this provision.

5.18 Verification of Employees’ Immigration Status

Contractor is required to enroll in and verify the work eligibility status of all newly-hired employees through the E-Verify program. (This is not required if the E-Verify program no longer exists). Contractor shall sign an affidavit, attached as Attachment C, affirming that Contractor does not knowingly employ an unauthorized alien. “Unauthorized alien” is defined at 8 U.S. Code 1324a(h)(3) as a person who is not a U.S. citizen or U.S. national and is not lawfully admitted for permanent residence or authorized to work in the U.S. under 8 U.S. Code Chapter 12 or by the U.S. Attorney General.

Contractor and any of its subcontractors may not knowingly employ or contract with an unauthorized alien, or retain an employee or contract with a person that the Contractor or any of its subcontractors learns is an unauthorized alien. If the City obtains information that the Contractor or any of its subcontractors employs or retains an employee who is an unauthorized alien, the City shall notify the Contractor or its subcontractors of the Agreement violation and require that the violation be remedied within thirty (30) calendar days of the date of notice. If the Contractor or any of its subcontractors verify the work eligibility status of the employee in question through the E-Verify program, there is a rebuttable presumption that the Contractor or its subcontractor did not knowingly employ an unauthorized alien. If the Contractor or its subcontractor fails to remedy the violation within the thirty (30) calendar day period, the City shall terminate the Agreement, unless the City determines that terminating the Agreement would be detrimental to the public interest or public property, in

which case the City may allow the Agreement to remain in effect until the City procures a new contractor. If the City terminates the Agreement, the Contractor or its subcontractor is liable to the City for actual damages.

Contractor shall require any subcontractors performing work under this Agreement to certify to the Contractor that, at the time of certification, the subcontractor does not knowingly employ or contract with an unauthorized alien and the subcontractor has enrolled in and is participating in the E-Verify program. Contractor shall maintain on file all subcontractors' certifications throughout the term of this Agreement with the City.

5.19 Drug Testing Plan

In accordance with Indiana Code 4-13-18 as amended, the CONTRACTOR was required to submit with his/her bid a written drug testing policy for a public works project that is estimated to cost \$150,000 or more. Among other things, the law sets forth specific requirements that must be in the plan for a program to test the employees of the CONTRACTOR and Subcontractors for drugs. The successful CONTRACTOR must comply with all provisions of the statute. This contract is subject to cancellation if CONTRACTOR fails to implement its testing program during the term of this contract, fails to provide information regarding this testing at the request of CITY; or provides false information to CITY regarding CONTRACTOR's employee drug testing program. CONTRACTOR shall sign an affidavit, attached as Attachment D, affirming that CONTRACTOR has and shall implement CONTRACTOR'S employee drug testing program throughout the term of this project.

IN WITNESS WHEREOF, the parties of this Agreement have hereunto set their hands.

DATE: _____

CITY OF BLOOMINGTON

SCENIC CONSTRUCTION SERVICES, INC.

BOARD OF PARK COMMISSIONERS

BY:

BY:

Kathleen Mills, President, Board of Park Commissioners

Tony Biasi, Scenic Construction Services

Paula McDevitt, Director, Parks and Recreation Dept.

Printed Name

Beth Cate, Corporation Counsel

ATTACHMENT "A"
"SCOPE OF WORK"

GRIFFY DAM TRAIL CROSSING

The Contractor shall provide all materials, labor, and equipment necessary to complete the following described project:

This project titled 'Griffy Lake Dam Trail Crossing' shall include, but is not limited to improvements including site preparation, excavation, earthwork, fill, approximately 850 feet of trail construction, demolition, installation of fencing, and the construction of an approximately 200-foot long staircase at the site of the Griffy Lake Dam on N Dunn St. in Bloomington, IN. Detailed information on the project is available on the construction plans and specifications provided in the bid packet. The contractor shall complete the work included in the base bid and alternate one.

All work shall meet requirements of the City of Bloomington. Compliance with the IDNR permit issued for this project (included in supplementary conditions) is required.

ATTACHMENT 'B'

**BIDDER'S AFFIDAVIT IN COMPLIANCE WITH INDIANA CODE 36-1-12-20 TRENCH SAFETY SYSTEMS;
COST RECOVERY**

STATE OF INDIANA)
) SS:
COUNTY OF _____)

AFFIDAVIT

The undersigned, being duly sworn, hereby affirms and says that:

1. The undersigned is the _____ of
(job title)

(company name)
2. The undersigned is duly authorized and has full authority to execute this Bidder's Affidavit.
3. The company named herein that employs the undersigned:
 - i. has contracted with or seeking to contract with the City of Bloomington to provide services; **OR**
 - ii. is a subcontractor on a contract to provide services to the City of Bloomington.
4. By submission of this Bid and subsequent execution of a Contract, the undersigned Bidder certifies that as successful Bidder (Contractor) all trench excavation done within his/her control (by his/her own forces or by his/her Subcontractors) shall be accomplished in strict adherence with OSHA trench safety standards contained in 29 C.F.R. 1926, Subpart P, including all subsequent revisions or updates to these standards as adopted by the United States Department of Labor.
5. The undersigned Bidder certifies that as successful Bidder (Contractor) he/she has obtained or will obtain identical certification from any proposed Subcontractors that will perform trench excavation prior to award of the subcontracts and that he/she will retain such certifications in a file for a period of not less than three (3) years following final acceptance.
6. The Bidder acknowledges that included in the various items listed in the Schedule of Bid Prices and in the Total Amount of Bid Prices are costs for complying with I.C. 36-1-12-20. The Bidder further identifies the costs to be summarized below*:

ATTACHMENT 'C'

"E-Verify AFFIDAVIT"

STATE OF INDIANA)
)SS:
COUNTY OF _____)

E-Verify AFFIDAVIT

The undersigned, being duly sworn, hereby affirms and says that:

1. The undersigned is the _____ of _____.
a. (job title) (company name)
2. The company named herein that employs the undersigned:
 - i. has contracted with or seeking to contract with the City of Bloomington to provide services; **OR**
 - ii. is a subcontractor on a contract to provide services to the City of Bloomington.
3. The undersigned hereby states that, to the best of his/her knowledge and belief, the company named herein does not knowingly employ an "unauthorized alien," as defined at 8 United States Code 1324a(h)(3).
4. The undersigned hereby states that, to the best of his/her belief, the company named herein is enrolled in and participates in the E-verify program.

Signature

Printed Name

STATE OF INDIANA)
)SS:
COUNTY OF _____)

Before me, a Notary Public in and for said County and State, personally appeared _____ and acknowledged the execution of the foregoing this ____ day of _____, 20__.

Notary Public's Signature

Printed Name of Notary Public

My Commission Expires: _____

County of Residence: _____

ATTACHMENT 'D'

COMPLIANCE AFFIDAVIT

REGARDING INDIANA CODE CHAPTER 4-13-18

DRUG TESTING OF EMPLOYEES OF PUBLIC WORKS CONTRACTORS

STATE OF INDIANA)

) SS:

COUNTY OF _____)

AFFIDAVIT

The undersigned, being duly sworn, hereby affirms and says that:

1. The undersigned is the _____ of
(job title)

(company name)
2. The undersigned is duly authorized and has full authority to execute this Affidavit.
3. The company named herein that employs the undersigned:
 - iii. has contracted with or seeking to contract with the City of Bloomington to provide services; **OR**
 - iv. is a subcontractor on a contract to provide services to the City of Bloomington.
4. The undersigned certifies that Contractor's submitted written plan for a drug testing program to test employees of the Contractor and Subcontractor for public works projects with an estimated cost of \$150,000 is in accordance with Indiana Code 4-13-18 as amended.
5. The undersigned acknowledges that this Contract shall be subject to cancellation should Contractor fail to comply all provisions of the statute.

Signature

Printed Name

STATE OF INDIANA)

) SS:

COUNTY OF _____)

Before me, a Notary Public in and for said County and State, personally appeared _____ and acknowledged the execution of the foregoing this _____ day of _____, 20____.

My Commission Expires: _____
Signature of Notary Public

County of Residence: _____
Printed Name of Notary Public

ATTACHMENT 'E'

STATE OF _____)
) SS:
COUNTY OF _____)

NON-COLLUSION AFFIDAVIT

The undersigned offeror or agent, being duly sworn on oath, says that he has not, nor has any other member, representative, or agent of the firm, company, corporation or partnership represented by him, entered into any combination, collusion or agreement with any person relative to the price to be offered by any person nor to prevent any person from making an offer nor to induce anyone to refrain from making an offer and that this offer is made without reference to any other offer.

OATH AND AFFIRMATION

I affirm under the penalties of perjury that the foregoing facts and information are true and correct to the best of my knowledge and belief.

Dated this _____ day of _____, 2023.

Contractor

By: _____

Signature

Printed Name

STATE OF _____)
) SS:
COUNTY OF _____)

Before me, a Notary Public in and for said County and State, personally appeared _____ and acknowledged the execution of the foregoing this _____ day of _____, 2023.

_____ My Commission Expires: _____

Notary Public's Signature

_____ County of Residence: _____

Printed Name of Notary Public

CONSTRUCTION PLANS FOR: GRIFFY LAKE LOOP TRAIL - DAM CROSSING

City of Bloomington Bid Documents

January 6, 2023

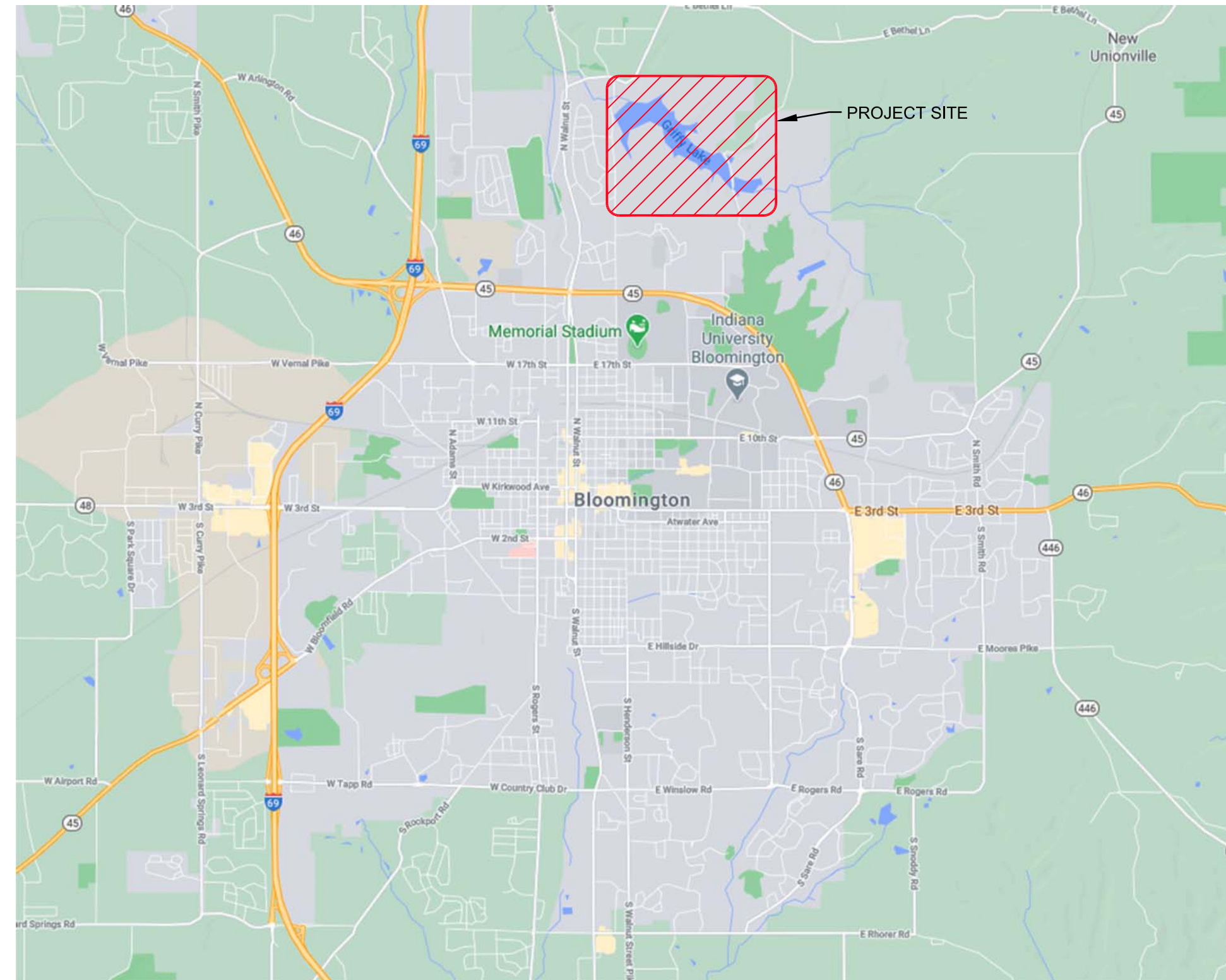

VICINITY MAP

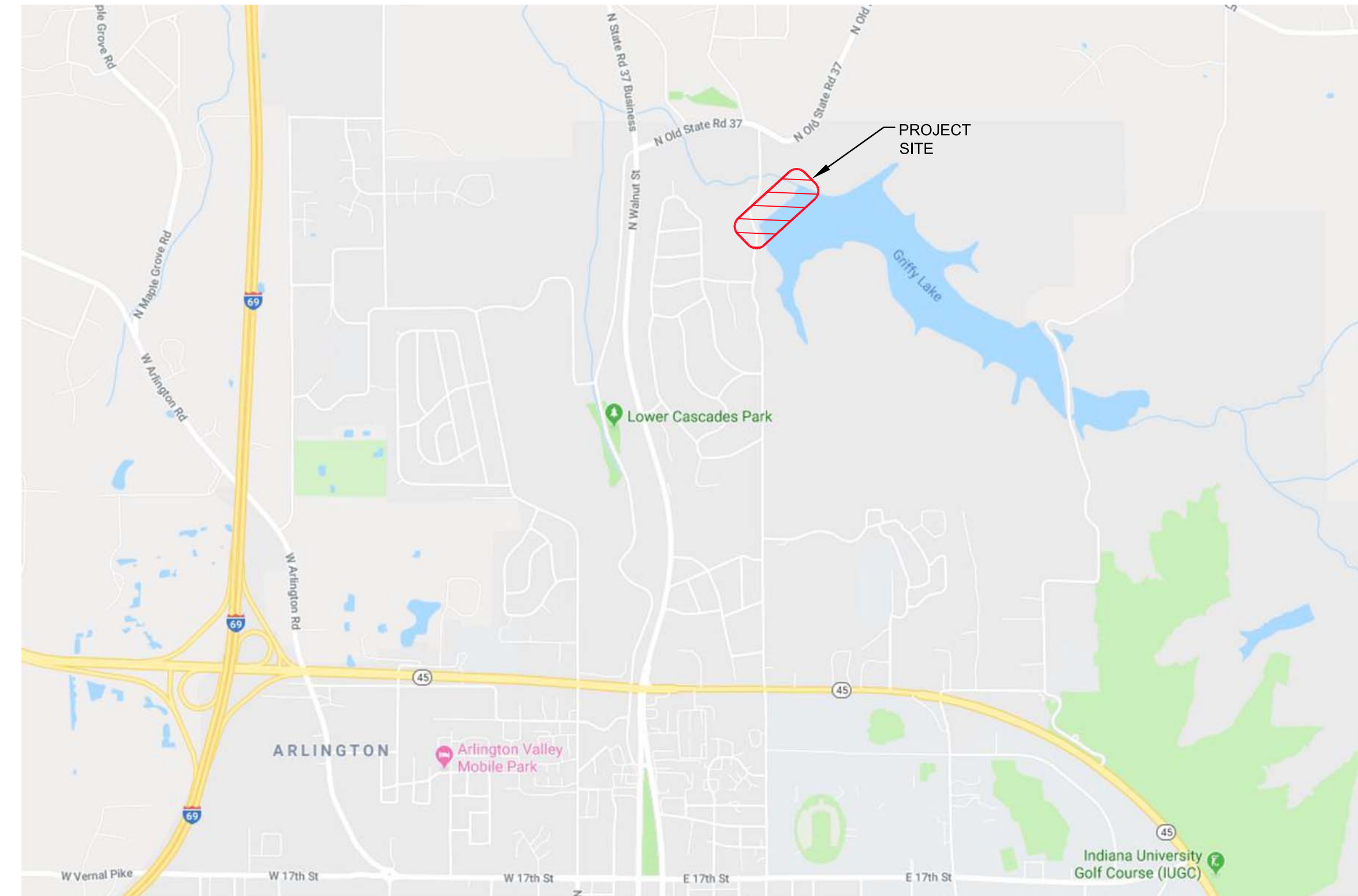

LOCATION MAP

PROJECT TEAM

OWNER :
Bloomington Parks & Recreation
401 N Morton St
Suite 250
Bloomington IN 47404

LANDSCAPE ARCHITECT:

Mader Design LLC
302 Main Street
Beech Grove, IN 46107

CIVIL ENGINEER:

LandWorx
958 E. Washington St., Suite 100
Indianapolis, IN 46202

SHEET INDEX

- G100 Cover, Location & Sheet Index
- SV-2 Survey
- SV-3 Survey
- D102 Site Demolition Plan
- L103 Site Layout Plan
- L104 Site Layout Plan - Enlargements
- L300 Site Details
- C401 Erosion Control Plan
- C410 Erosion Control Details

ALTERNATE #1 - WOOD FENCE
BASE BID: PROVIDE WOOD
FENCE TO MATCH WOOD STAIR
HANDRAIL PER DETAIL 4/L300
ALTERNATE: PROVIDE WOOD
FENCE PER DETAIL 7/L300

DRAFT - NOT FOR CONSTRUCTION

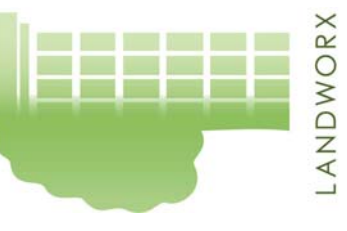

prepared for:
BLOOMINGTON PARKS
Griffy Lake Loop Trail - Dam Crossing
Bid Documents
3400 N. Mosley Road
Bloomington, Indiana 47408

project:

revision:	date:	description:



date: 01.06.23
job #:
drawn by: KB
checked by: JMJ/T

Landscape Architect is the author and owner of these drawings and specifications. They shall be used solely for the purposes of this project and shall not be used for any other Project or Work without expressed permission of the Landscape Architect.

sheet number:
G100

GRIFFY LAKE TOPOGRAPHIC SURVEY

A PART OF THE NORTHEAST QUARTER OF
SECTION 21, T9N, R1W
MONROE COUNTY, INDIANA

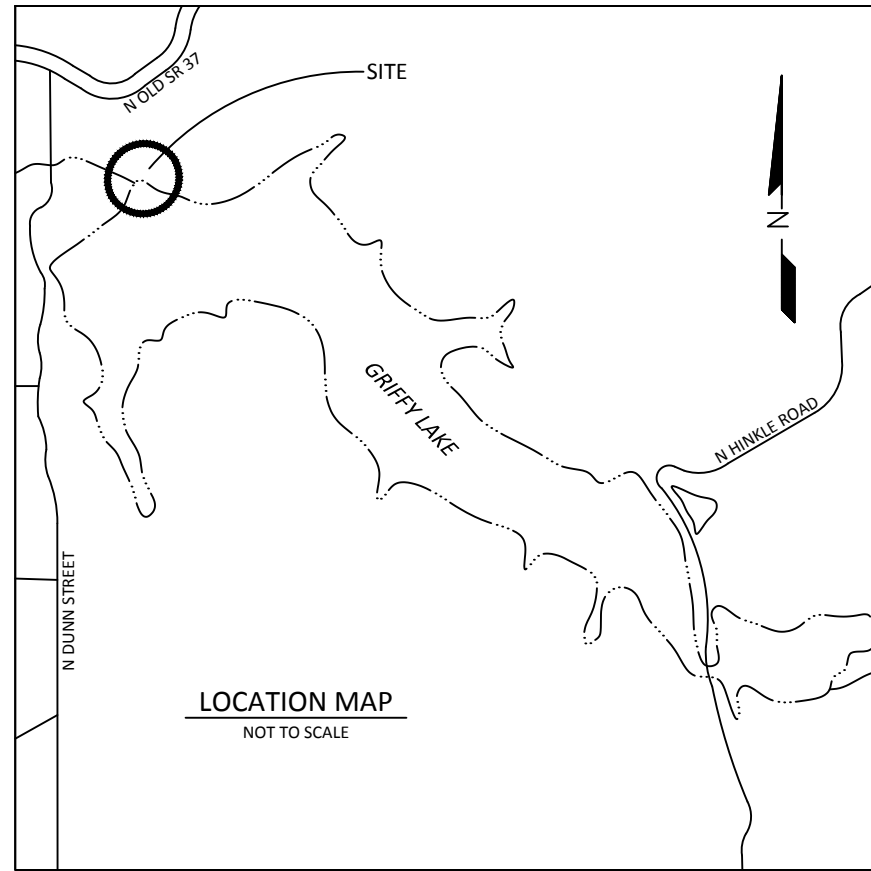

LEGEND:

▲ YARD LIGHT	— FENCE	⊗ FD AXLE
⊗ LIGHT POLE	— GUARDRAIL	⊗ FD BRASS DISK
⊗ SIGNAL POLE	— OVERHEAD WIRES	⊗ FD COT GIN SPIDLE
⊗ UTILITY POLE	— UG# UNDER ELEC.	⊗ FD CHISELED X
— GUY WIRE	— GAS LINE	⊗ SET CHISELED X
⊗ CATCH BASIN	— SAN SEWER LINE	⊗ SET DRILL HOLE
⊗ CURB INLET	— ST STORM SEWER LINE	⊗ FD HARRISON MON.
⊗ ELECTRIC MH	— UT UNDER TELEPHONE	⊗ SET HARRISON MON.
⊗ MANHOLE	— EXISTING WATER LINE	⊗ SET HUB/TACK
⊗ PHONE MH	— CH.W# CHILLED WATER LINE	⊗ FD REBAR
⊗ SANITARY MH	— SIGN	⊗ SET REBAR
⊗ SIGNAL MH	— R.O.W. MON.	⊗ FD MAG NAIL
⊗ STEAM MH	— MONITORING WELL	⊗ SET MAG NAIL
⊗ STORM MH	— BOLLARD	⊗ FD NAIL
⊗ WATER MH	— BORE HOLE	⊗ SET NAIL
⊗ ELEC. METER	— DOWNSPOUT	⊗ FD PIPE
⊗ CLEANOUT	— GATE POST	⊗ FD RR SPIKE
⊗ GAS METER	— P.MTR. PARKING METER	⊗ SET RR SPIKE
⊗ GAS VALVE	— S.P. SPOUT	⊗ FD STONE
⊗ WATER VALVE	— T-POST	⊗ RECORDED B&D
⊗ FIRE HYDRANT	— WOOD POST	⊗ CALCULATED B&D
⊗ SPR. HOOKUP	— PARKING SPACES	⊗ PROPORTIONAL DIST.
⊗ SPRINKLER	— TRANSFORMER	⊗ A.G. ABOVE GROUND
⊗ LIMESTONE BLOCK	— ELEC. VAULT	⊗ B.G. BELOW GROUND
	— GAS METER VAULT	⊗ CONIF. TREE
	— VALVE VAULT	⊗ DECID. TREE
	— PHONE VAULT	⊗ SHRUB
	— AC UNIT	⊗ PHONE RISER-BOX
	— PHONE BOOTH	⊗ TV RISER-BOX
	— FIRE MAIN POST	⊗ ELEC. RISER-BOX
	— MAILBOX	⊗ GAS RISER-BOX
	— PROF. TANK	
	— PARKING BLOCK	
	— POST	

NOTES:

- FIELD WORK PERFORMED DECEMBER 2019 AND JULY 2020.
- CONTOURS REPRESENT 1-FOOT INTERVALS.
- UTILITIES SHOWN HEREON ARE PER OBSERVED ABOVE GROUND EVIDENCE AND FROM UTILITY MARKINGS PLACED ON THE GROUND BY INDIANA S11 MEMBER UTILITIES (SEE TICKETS BELOW). MEMBER UTILITIES DO NOT LOCATE PRIVATE LINES OR FACILITIES. MEMBER UTILITIES DO NOT LOCATE SERVICE LINES NOR ALL UTILITIES WHEN A SURVEY IS THE PURPOSE OF THE TICKET. OVERHEAD UTILITIES ARE IDENTIFIED AS OVERHEAD WITHOUT SPECIAL INVESTIGATION AS TO THE TYPE OR NATURE. STORM AND SANITARY INVERT ELEVATIONS, PIPE SIZES, AND MATERIALS ARE ALL APPROXIMATE BASED ON LIMITED INFORMATION AVAILABLE FROM THE SURFACE. NO STRUCTURES WERE ENTERED TO ACCURATELY MEASURE PIPE SIZES OR TO VERIFY PIPE TYPE AND MATERIAL. STRUCTURE GRATES AND COVERS SHOWN SHOULD NOT BE ASSUMED TO BE THE CENTER OF THE BELOW GROUND STRUCTURE. ALL UTILITIES INCLUDING LOCATIONS AND SIZES NEED TO BE VERIFIED PRIOR TO CONSTRUCTION EFFORTS.
- THE FOLLOWING IS THE INDIANA 811 TICKET NUMBERS FOR THIS PROJECT:
2001023172
- THE FOLLOWING ARE THE MEMBER UTILITIES NOTIFIED BY INDIANA 811:
AT&T - DISTRIBUTION: COMMUNICATIONS
CITY OF BLOOMINGTON UTILITIES: WATER, SEWER
DUKE ENERGY: ELECTRIC
VECTREN (BLOOMINGTON): GAS
- The utilities shown on this survey represent Quality Level B standard of care. The American Society of Civil Engineers (ASCE) has developed an important standard of care guideline, Standard Guideline for the Collection and Depiction of Existing Subsurface Utility Data, CI/ASCE 38-02. This standard guideline describes four quality levels of utility depiction:
Quality Level D - Information derived from existing records or oral recollections.
Quality Level C - Information obtained by surveying and plotting visible above-ground utility features and by using professional judgment in correlating this information to Quality Level D.
Quality Level B - Information obtained through the application of appropriate surface geophysical methods to determine the existence and approximate horizontal position of subsurface utilities.
Quality Level A - Precise horizontal and vertical location of utilities obtained by the actual exposure and subsequent measurement of subsurface utilities, usually at a specific point.
To order a copy of ASCE Standard 38-02, please go to the ASCE Bookstore: <http://www.pubs.asce.org/> or call 1-800-548-2723.

CONTROL POINTS:

HORIZONTAL DATUM: Indiana State Plane Coordinates Zone West, U.S. Survey Feet.
VERTICAL DATUM: NAVD88 (Computed using Geoid 12B), U.S. Survey Feet.

POINT #	NORTHING	EASTING	ELEVATION	DESCRIPTION
1	1439054.2180	3114575.4900	634.74	NAIL SET
2	1439059.1289	3114672.0804	635.81	NAIL SET
3	1439172.8275	3114457.6277	634.88	MAG NAIL
4	1439291.6253	3114293.9834	636.52	MAG NAIL
5	1438591.2463	3114320.2724	641.40	MAG NAIL
6	1439775.9539	3114091.9032	636.83	MAG NAIL
7	1439894.3707	3113970.1523	640.92	MAG NAIL
24	1439894.3707	3113970.1523	640.92	MAG NAIL
1560	1439131.2019	3114278.8635	631.59	NAIL SET
2317	1441904.3880	3110311.2960	603.23	NAIL SET
2512	1441943.0620	3110503.8550	643.43	NAIL SET
2600	1441313.9330	3109852.5710	647.22	MAG NAIL W/ PINK WHISKER
2601	1441590.3660	3109847.9180	596.82	5/8" REBAR W/ WITNESS CAP
2729	1441604.5410	3109813.2640	599.96	MAG NAIL



Date	7-8-20
By	RSI
Revision	Additional topo along dam

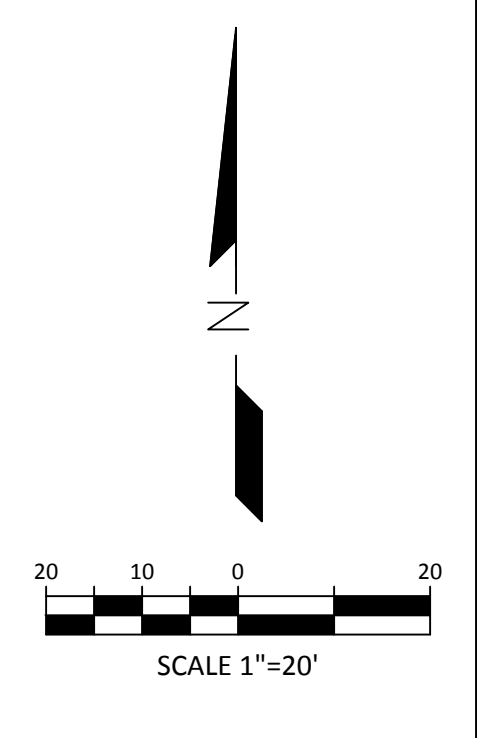

BRCU
Blair Riggert Cooper James
LAND SURVEYING - CIVIL ENGINEERING - GIS
1951 West Tapp Road Bloomington, Indiana 47403
Phone: 812-336-8277 Email: ccenter@brcju.com

GRIFFY LAKE
TOPOGRAPHIC SURVEY
BLOOMINGTON, INDIANA
FOR
MADER DESIGN

SURVEYED BY:	J.L. G.W., C.M.
DRAWN BY:	R.S.I.
CHECKED BY:	C.L.P.
DATE:	JANUARY 2020
TOPOGRAPHIC SURVEY	
SHEET	2 OF 3
PROJECT NO.	9568

GRIFFY LAKE TOPOGRAPHIC SURVEY

A PART OF THE NORTHEAST QUARTER OF
SECTION 21, T9N, R1W
MONROE COUNTY, INDIANA

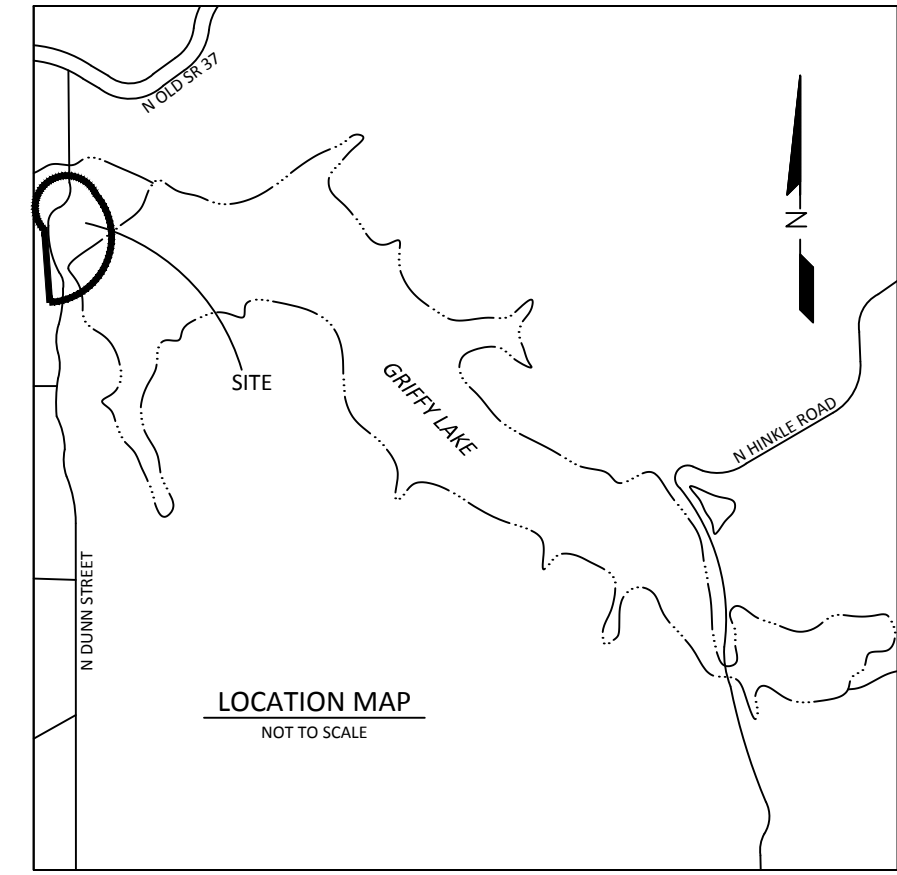

LEGEND:

▲ YARD LIGHT	— FENCE	⊙ FD AXLE
⊙ LIGHT POLE	— GUARDRAIL	⊙ FD BRASS DISK
⊙ SIGNAL POLE	— OVERHEAD WIRES	⊙ FD COT GIN SPOLE
⊙ UTILITY POLE	— UNDER ELEC.	⊙ FD CHISELED X
⊙ GUY WIRE	— GAS	⊙ SET CHISELED X
⊙ CATCH BASIN	— SAN SEWER LINE	⊙ SET DRILL HOLE
⊙ CURB INLET	— ST	⊙ FD HARRISON MON.
⊙ ELECTRIC MH	— UNDER TELEPHONE	⊙ SET HARRISON MON.
⊙ MANHOLE	— EXISTING WATER LINE	⊙ SET HUB/TACK
⊙ PHONE MH	— CH/WATER	⊙ FD REBAR
⊙ SANITARY MH	— CH/WATER	⊙ SET REBAR
⊙ SIGNAL MH	— SIGN	⊙ FD MAG NAIL
⊙ STEAM MH	— R.O.W. MON.	⊙ SET MAG NAIL
⊙ STORM MH	— MONITORING WELL	⊙ FD NAIL
⊙ WATER MH	— BOLLARD	⊙ SET NAIL
⊙ ELEC. METER	— BORE HOLE	⊙ FD PIPE
⊙ CLEANOUT	— GATE POST	⊙ FD RR SPIKE
⊙ GAS METER	— POLE	⊙ SET RR SPIKE
⊙ GAS VALVE	— P.MTR	⊙ FD STONE
⊙ WATER VALVE	— SPIGOT	⊙ RECORDED B&D
⊙ FIRE HYDRANT	— T-POST	⊙ MEASURED B&D
⊙ SPR. HOOKUP	— WOOD POST	⊙ CALCULATED B&D
⊙ SPRINKLER	— PARKING SPACES	⊙ PROPORTIONAL DIST.
⊙ LIMESTONE BLOCK	— TRANSFORMER	⊙ A.G. ABOVE GROUND
	— ELEC. VAULT	⊙ B.G. BELOW GROUND
	— PHONE VAULT	⊙ CONF. TREE
	— STEAM VAULT	⊙ SHRUB
	— VALVE VAULT	⊙ DECID. TREE
	— AC UNIT	⊙ PHONE RISER-BOX
	— PHONE BOOTH	⊙ TV RISER-BOX
	— FIRE MAIN POST	⊙ ELEC. RISER-BOX
	— PROF. TANK	⊙ GAS RISER-BOX
	— MAILBOX	
	— PARKING BLOCK	
	— POST	

CONTROL POINTS:

HORIZONTAL DATUM: Indiana State Plane Coordinates Zone West, U.S. Survey Feet.
VERTICAL DATUM: NAVD88 (Computed using Geoid 12B), U.S. Survey Feet.

POINT #	NORTHING	EASTING	ELEVATION	DESCRIPTION
1	1439054.2180	3114575.4900	634.74	NAIL SET
2	1439059.1289	31144672.0804	635.81	NAIL SET
3	1439172.8275	3114457.6277	634.88	MAG NAIL
4	1439291.6253	3114293.9834	636.52	MAG NAIL
5	1438591.2463	3114320.2724	641.40	MAG NAIL
6	1439775.9539	3114091.9032	636.83	MAG NAIL
7	1438894.3707	3113970.1523	640.92	MAG NAIL
24	1438894.3707	3113970.1523	640.92	MAG NAIL
1560	1439131.2019	3114278.8635	631.59	NAIL SET
2317	1441904.3880	3110311.2960	603.23	NAIL SET
2512	1441943.0620	3110503.8550	643.43	NAIL SET
2600	1441313.9330	3109852.5710	647.22	MAG NAIL W/ PINK WHISKER
2601	1441590.3660	3109847.9180	596.82	5/8" REBAR W/ WITNESS CAP
2729	1441604.5410	3109813.2640	599.96	MAG NAIL

NOTES:

- FIELD WORK PERFORMED DECEMBER 2019 AND JULY 2020.
 - CONTOURS REPRESENT 1-FOOT INTERVALS.
 - UTILITIES SHOWN HEREON ARE PER OBSERVED ABOVE GROUND EVIDENCE AND FROM UTILITY MARKINGS PLACED ON THE GROUND BY INDIANA811 MEMBER UTILITIES (SEE TICKETS BELOW). MEMBER UTILITIES DO NOT LOCATE PRIVATE LINES OR FACILITIES. MEMBER UTILITIES DO NOT LOCATE SERVICE LINES NOR ALL UTILITIES WHEN A SURVEY IS THE PURPOSE OF THE TICKET. OVERHEAD UTILITIES ARE IDENTIFIED AS OVERHEAD WITHOUT SPECIAL INVESTIGATION AS TO THE TYPE OR NATURE. STORM AND SANITARY INVERT ELEVATIONS, PIPE SIZES, AND MATERIALS ARE ALL APPROXIMATE BASED ON LIMITED INFORMATION AVAILABLE FROM THE SURFACE. NO STRUCTURES WERE ENTERED TO ACCURATELY MEASURE PIPE SIZES OR TO VERIFY PIPE TYPE AND MATERIAL. STRUCTURE GRATES AND COVERS SHOWN SHOULD NOT BE ASSUMED TO BE THE CENTER OF THE BELOW GROUND STRUCTURE. ALL UTILITIES INCLUDING LOCATIONS AND SIZES NEED TO BE VERIFIED PRIOR TO CONSTRUCTION EFFORTS.
 - THE FOLLOWING IS THE INDIANA 811 TICKET NUMBERS FOR THIS PROJECT: 2001023247
 - THE FOLLOWING ARE THE MEMBER UTILITIES NOTIFIED BY INDIANA 811:
 - AT&T - DISTRIBUTION: COMMUNICATIONS
 - CITY OF BLOOMINGTON UTILITIES: WATER, SEWER
 - DUKE ENERGY: ELECTRIC
 - VECTREN (BLOOMINGTON): GAS
 - ZAYO BANDWIDTH: FIBER OPTIC
 - The utilities shown on this survey represent Quality Level B standard of care. The American Society of Civil Engineers (ASCE) has developed an important standard of care guideline, Standard Guideline for the Collection and Depiction of Existing Subsurface Utility Data, C/ASCE 38-02. This standard guideline describes four quality levels of utility depiction:
 - Quality Level D - Information derived from existing records or oral recollections.
 - Quality Level C - Information obtained by surveying and plotting visible above-ground utility features and by using professional judgment in correlating this information to Quality Level D.
 - Quality Level B - Information obtained through the application of appropriate surface geophysical methods to determine the existence and approximate horizontal position of subsurface utilities.
 - Quality Level A - Precise horizontal and vertical location of utilities obtained by the actual exposure and subsequent measurement of subsurface utilities, usually at a specific point.
- To order a copy of ASCE Standard 38-02, please go to the ASCE Bookstore: <http://www.pubs.asce.org/> or call 1-800-548-2723.

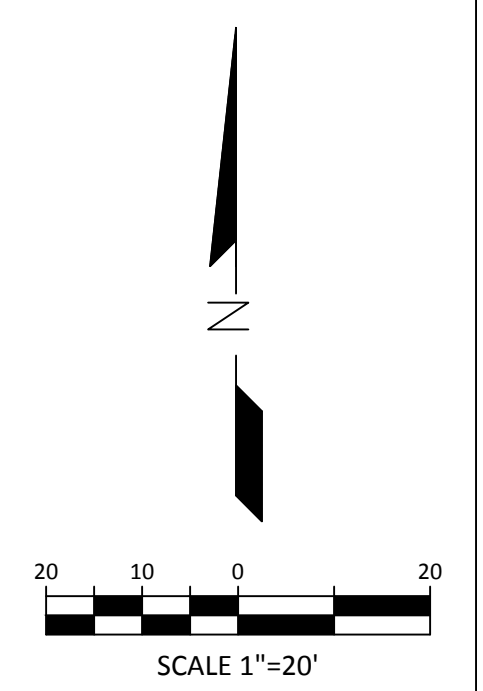
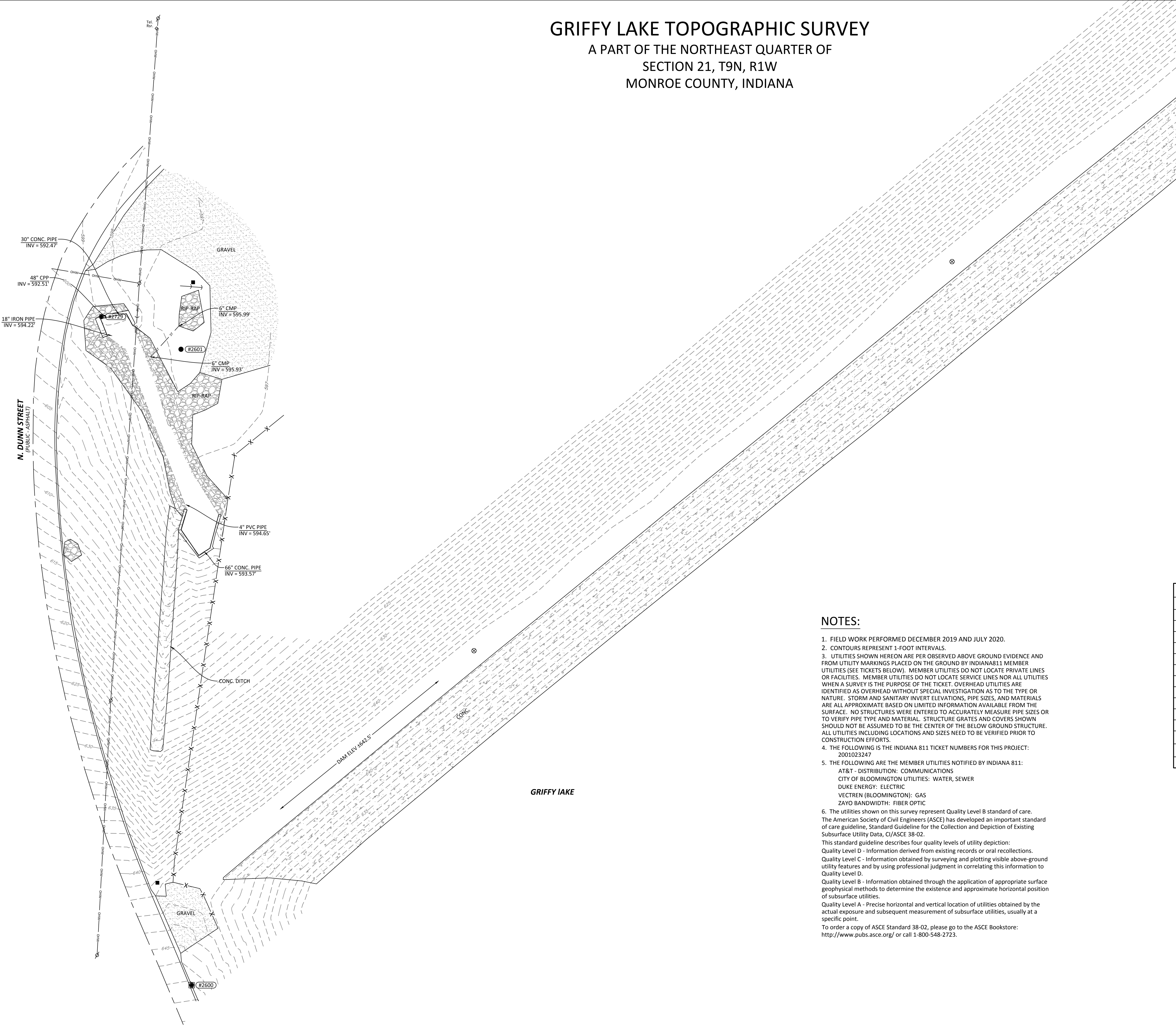

BRCJ
Blodcoe Riggert Cooper James
LAND SURVEYING - CIVIL ENGINEERING - GIS
951 West Tapp Road
Bloomington, Indiana 47403
Phone: 812-336-8277 Email: cprater@brcjvl.com

**GRIFFY LAKE
TOPOGRAPHIC SURVEY
BLOOMINGTON, INDIANA
FOR
MADER DESIGN**

SURVEYED BY: J.L. G.W., C.M.
DRAWN BY: R.S.I.
CHECKED BY: C.L.P.
DATE: JANUARY 2020
TOPOGRAPHIC SURVEY
SHEET 3 OF 3
PROJECT NO. 9568

GENERAL DEMOLITION NOTES

- A. ALL TOPOGRAPHIC AND SURVEY INFORMATION HAS BEEN OBTAINED FROM BLEDSOE RIGGERT COOPER JAMES, DATED JANUARY 2020. LANDSCAPE ARCHITECT CLAIMS NO RESPONSIBILITY FOR THE ACCURACY OF THE INFORMATION PROVIDED IN THIS SURVEY
- B. CONTRACTOR SHALL MAINTAIN UTILITY SERVICE AND PROVIDE ADA ACCESS TO THE BUILDINGS THROUGHOUT THE CONSTRUCTION TIMELINE.
- C. CONTRACTOR SHALL LOCATE ALL PUBLIC AND PRIVATE UTILITIES PRIOR TO COMMENCING WORK
- D. NO MATERIALS OR STOCKPILE MATERIALS SHALL BE STORED WITHIN THE PROTECTED ROOT ZONE OF TREES
- E. DAMAGE TO TREES OR WORK WITHIN THE PROTECTED ROOT ZONE OF THE EXISTING TREES SHALL SUBJECT THE CONTRACTOR TO DAMAGES DETERMINED BY THE OWNER.
- F. REMOVE TURF TO PREPARE FOR NEW PLANTING BEDS. SEE PLANTING PLAN FOR LOCATIONS
- G. CONTRACTOR SHALL GRADE AND SEED ALL AREAS DISTURBED BY CONSTRUCTION ACTIVITIES. ANYTHING DAMAGED BY CONTRACTORS ACTIVITIES SHALL BE REPAIRED OR REPLACED AT NO ADDITIONAL CHARGE TO THE OWNER. DAMAGING PROTECTED TREES, AND TRACKING SEDIMENT ONTO A PUBLIC STREET ARE VIOLATIONS OF CITY CODE AND WILL BE TREATED AS SUCH.
- H. CONTRACTOR SHALL VISIT THE SITE PRIOR TO BIDDING TO UNDERSTAND ALL SCOPE OF DEMOLITION ACTIVITIES. WHILE EFFORTS HAVE BEEN MADE TO IDENTIFY MAJOR COMPONENTS OF DEMOLITION, NO ADDITIONS TO THE CONTRACT WILL BE ALLOWED FOR VISIBLE DEMOLITION WORK REQUIRED TO ACCOMMODATE NEW CONSTRUCTION ACTIVITIES.
- I. CONTRACTOR SHALL REMOVE ANY EXCESS SOIL FROM SITE AND/OR PROVIDE ANY ADDITIONAL SOILS AS REQUIRED TO MEET PROPOSED GRADES.
- J. WHERE PAVEMENT IS INDICATED TO BE DEMOLISHED OR REMOVED, CONTRACTOR SHALL SAW CUT AND/OR CLEANLY REMOVE TO NOT DAMAGE ADJACENT OR ATTACHED PAVEMENT.
- K. CONTRACTOR SHALL BE RESPONSIBLE TO REPLACE OR REPAIR TO OWNER'S SATISFACTION ANY EXISTING IMPROVEMENTS TO REMAIN.
- L. CONTRACTOR TO REMOVE AND LEGALLY DISPOSE OF ALL DEMOLISHED ITEMS. COORDINATE STORAGE OR RETURN TO OWNER ANY ITEMS TO BE SALVAGED.
- M. PRIOR TO DEMOLITION, CONTRACTOR SHALL CONTACT CITY OF BLOOMINGTON UTILITIES AND COORDINATE REGARDING LOWERING OF THE RESERVOIR WATER LEVEL FOR DURATION OF CONSTRUCTION.

NOTE:
RETURN ENTIRE SITE TO ORIGINAL CONDITIONS
ONCE CONSTRUCTION IS COMPLETE.

DEMOLITION SCHEDULE - DAM

SYMBOL	DESCRIPTION	QTY	DETAIL
D-16	REMOVE CHAIN LINK FENCE TO NEAREST POST		
D-17	REMOVE BARBED WIRE FROM EXISTING FENCE		
D-18	REMOVE GATE BETWEEN POSTS		
D-19	REMOVE DOUBLE GATE, FENCE PANEL, AND POST BETWEEN		

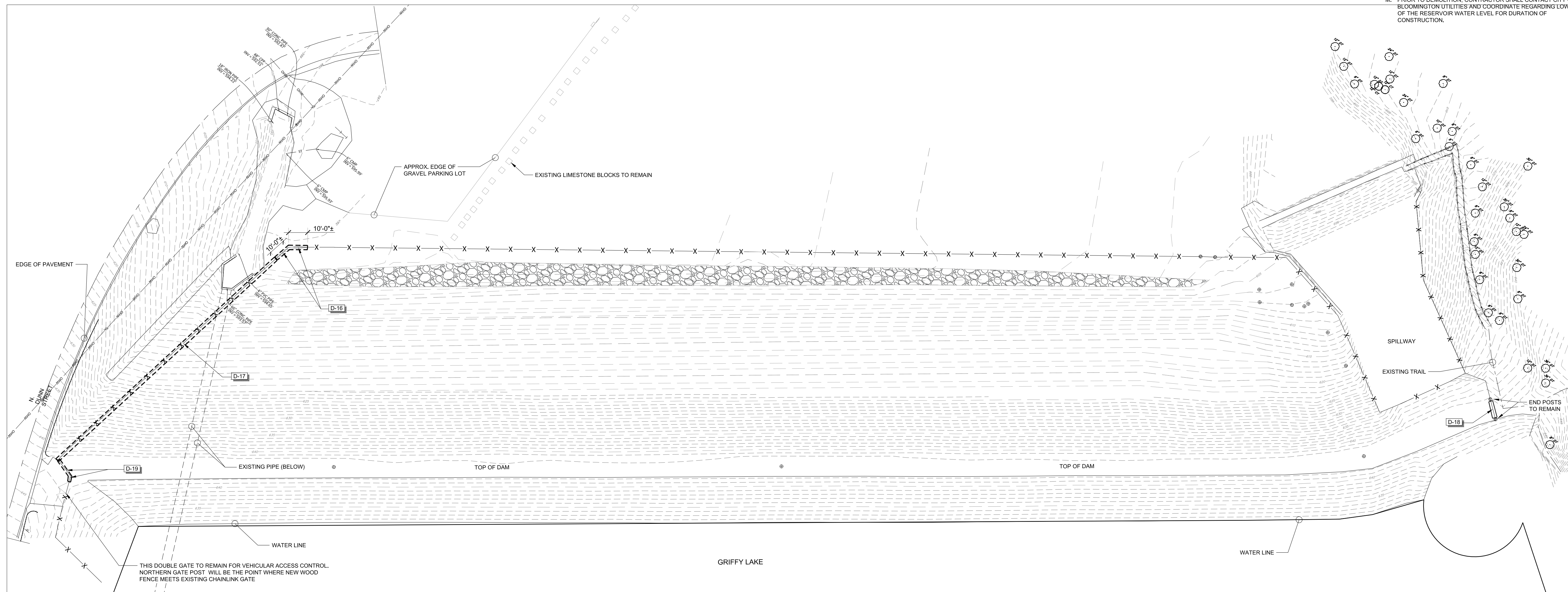

1 DAM - DEMOLITION PLAN

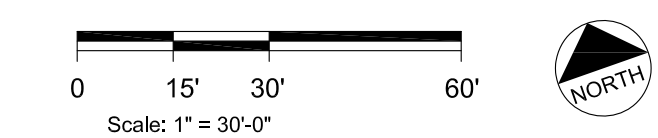

landscape architect:



consultant:



prepared for:



BLOOMINGTON PARKS
Griffy Lake Loop Trail - Dam Crossing
Bid Documents
3400 N. Healthy Road
Bloomington, Indiana 47408

Site Demolition Plan
Dam

revision:	date:	description:



date: 01.06.23
job #:
drawn by: KB
checked by: JMJ/T

Landscape Architect is the author and owner of these drawings and specifications. They shall be used solely for the purpose of this project and shall not be used for any other Project or Work without expressed permission of the Landscape Architect.

Sheet number:
D102

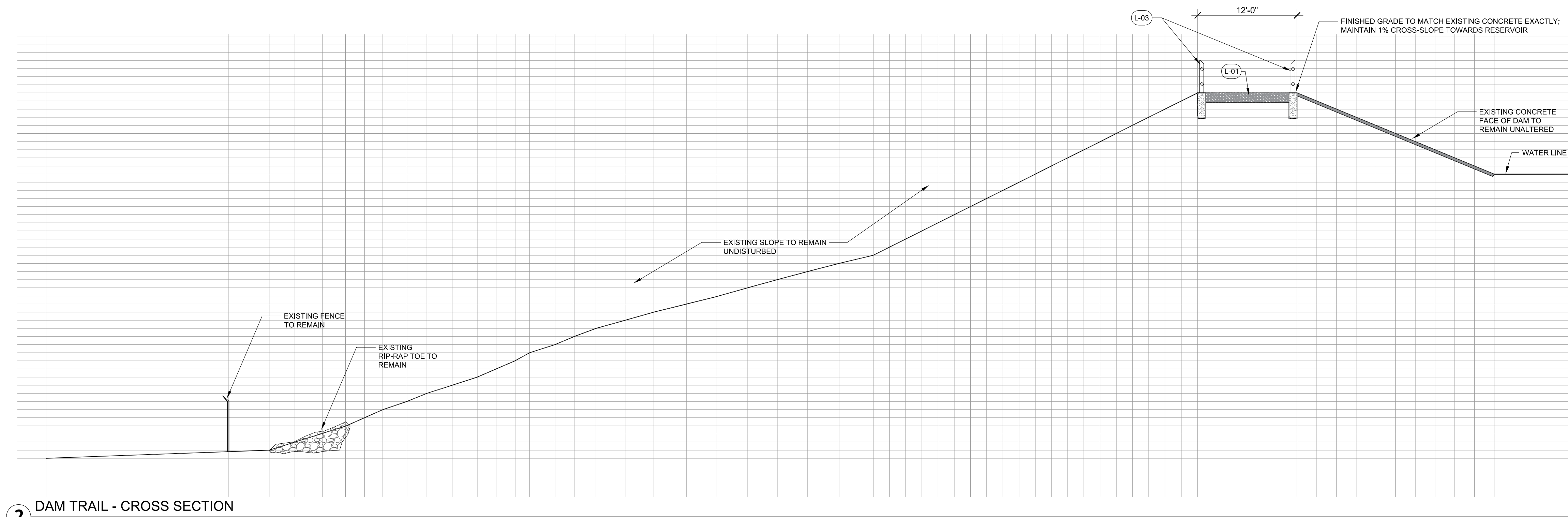

2 DAM TRAIL - CROSS SECTION

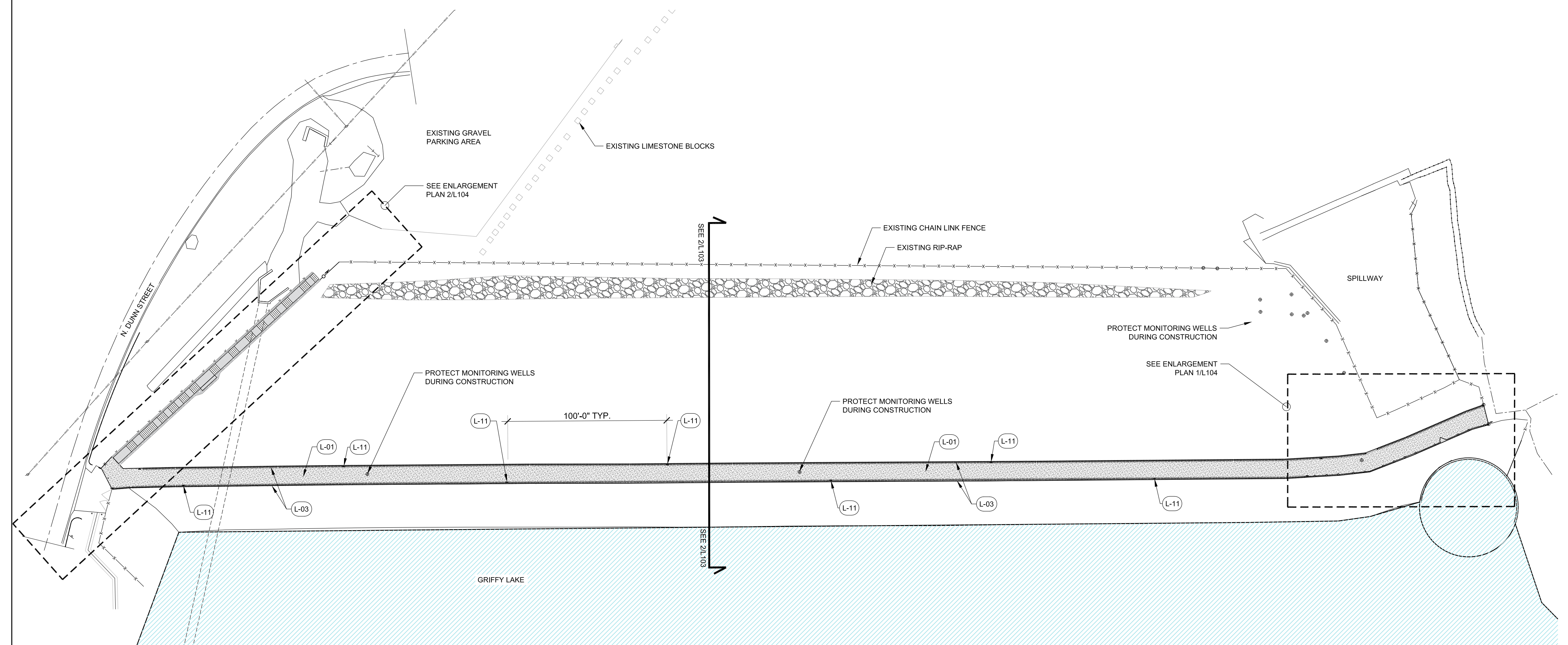

1 DAM CROSSING - LAYOUT PLAN

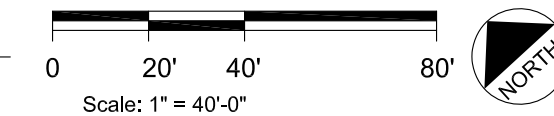

ALTERNATE #1 - WOOD FENCE
BASE BID: PROVIDE WOOD FENCE TO MATCH WOOD STAIR HANDRAIL PER DETAIL 4/L300
ALTERNATE: PROVIDE WOOD FENCE PER DETAIL 7/L300

LAYOUT SCHEDULE

SYMBOL	DESCRIPTION	DETAIL
(L-01)	GRAVEL TRAIL SURFACE	1/L300
(L-02)	RIP-RAP	
(L-03)	WOOD FENCE; FOR BASE BID USE WOOD STAIR HANDRAIL DESIGN IN DETAIL 4/L300. FOR ALTERNATE #1 USE WOOD FENCE DESIGN SHOWN 7/L300	7/L300
(L-04)	REMOVABLE FENCE SECTION; INTENDED TO BE PERIODICALLY AND TEMPORARILY REMOVED FOR ACCESS BY DAM MAINTENANCE CREWS, AND EASILY REPLACED	
(L-05)	CHAIN LINK FENCE; 6' HEIGHT, WIRE FABRIC, POSTS AND BRACING TO MATCH EXISTING ADJACENT CHAIN LINK FENCE	
(L-06)	GATE; 4' WIDTH, MATCH CHAIN LINK FENCE	
(L-07)	WOOD DECK	5/L300
(L-08)	WOOD STAIRS	3/L300
(L-09)	WOOD STAIR HANDRAIL	4/L300
(L-10)	WOOD BENCH SEAT ON LANDING	6/L300
(L-11)	SAFETY SIGNAGE DIRECTING TRAIL USERS TO STAY ON DESIGNATED PATH; SIGN DESIGN AND VERBIAGE TO BE DETERMINED BY CITY OF BLOOMINGTON	
(L-12)	TRAIL RULES SIGN; VERBIAGE TO BE DETERMINED BY THE CITY OF BLOOMINGTON, RECOMMENDED 'SIGN TYPE H' FROM BLOOMINGTON PARKS AND RECREATION SIGN DESIGN MANUAL	
(L-13)	TIMBER BOLLARD	2/L300
(L-14)	COLLAPSIBLE BOLLARD; 'TRAFFIC GUARD' HINGED ROUND POST HRP48, OR APPROVED EQUAL	

GENERAL SITE LAYOUT NOTES

- ALL TOPOGRAPHIC AND SURVEY INFORMATION HAS BEEN OBTAINED FROM BLEDSOE RIGGERT COOPER JAMES, DATED JANUARY 2020. LANDSCAPE ARCHITECT CLAIMS NO RESPONSIBILITY FOR ACCURACY OF INFORMATION PROVIDED. VERIFY AND CONFIRM ALL EXISTING CONDITIONS PRIOR TO CONSTRUCTION.
- LOCATE AND VERIFY ALL PUBLIC AND PRIVATE UTILITIES PRIOR TO STARTING WORK.
- STAKE AND CONFIRM ALL DIMENSIONS AND GRADES PRIOR TO STARTING WORK. REPORT ANY DISCREPANCIES TO OWNERS REPRESENTATIVE IMMEDIATELY. DRAWINGS SHALL NOT BE SCALED FOR LAYOUT PURPOSES.
- PROVIDE SMOOTH TRANSITION FROM NEW AREAS TO EXISTING FEATURES AS NECESSARY.
- WHERE NEW PAVEMENT IS SHOWN TO MEET EXISTING, SAW CUT EXISTING PAVEMENT VERTICALLY, REMOVE DELETERIOUS MATERIAL, AND PREPARE FOR NEW WORK.
- ALL AREAS WHERE PROPOSED ASPHALT PAVEMENT MEETS THE EXISTING PAVEMENT THE EXISTING PAVEMENT EDGE SHALL BE SAW CUT VERTICALLY AND PROPERLY SEALED WITH A TACK COAT MATERIAL.
- ALL DIMENSIONS IN CURBED AREAS SHALL BE TO FACE OF CURB, ALL DIMENSIONS IN AREAS WITHOUT CURBING SHALL BE TO EDGE OF PAVEMENT. ALL DIMENSIONS AT INTEGRAL CURB AND WALK SHALL BE TO FACE OF CURB. ALL DIMENSIONS FROM BUILDING SHALL BE FROM FACE OF BUILDING.
- ALL DIMENSIONS ARE PARALLEL AND PERPENDICULAR TO BASE LINES, PROPERTY LINES OR BUILDING LINES UNLESS OTHERWISE NOTED.
- ALL RADII INDICATED SHALL BE FORMED AS CIRCULAR ARCS. ALL CURBS AND ARCS SHALL INTERSECT OTHER CURBS AND LINES AT POINTS OF TANGENCY TO FORM SMOOTH TRANSITIONS UNLESS CLEARLY SHOWN OTHERWISE.
- RADII SHALL BE 5'-0" ON PARKING LOTS, CONCRETE WALKS AND ASPHALT TRAILS UNLESS OTHERWISE NOTED OR WHERE DRAWING APPEARS SIGNIFICANTLY DIFFERENT.
- WHERE NOT SHOWN, CONCRETE SIDEWALK AND RETAINING WALL EXPANSION JOINTS SHALL BE 30'-0" O.C. AND CONTROL JOINTS 5'-0" O.C. MAX. CURB EXPANSION JOINTS SHALL BE 9'-0" O.C. MAX AND AT ALL 90 DEGREE ANGLES. CONTROL JOINTS SHALL ALIGN WITH ADJACENT SIDEWALK WHERE APPLICABLE, OTHERWISE 10'-0" MAXIMUM SPACING SHALL BE USED.
- ACCESSIBLE RAMPS AND SIGNAGE SHALL BE IN ACCORDANCE WITH FEDERAL, STATE, COUNTY, CITY AND LOCAL CODES (WHICHEVER HAS JURISDICTION). SEE SITE PLANS FOR LOCATIONS AND SITE DETAILS FOR SPECIFICATIONS.
- SEED ALL AREAS DISTURBED BY CONSTRUCTION ACTIVITIES AND NOT CALLED OUT TO BE PAVED OR PLANTED WITH OTHER PLANT MATERIAL.
- CONTRACTOR SHALL OBTAIN ALL PERMITS AND COORDINATE WITH LOCAL REGULATORY AGENCIES AS REQUIRED BY LOCAL JURISDICTIONS.

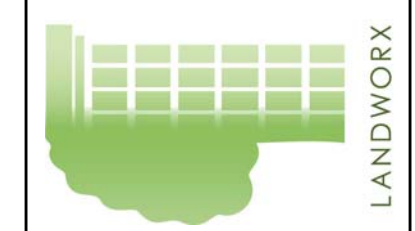
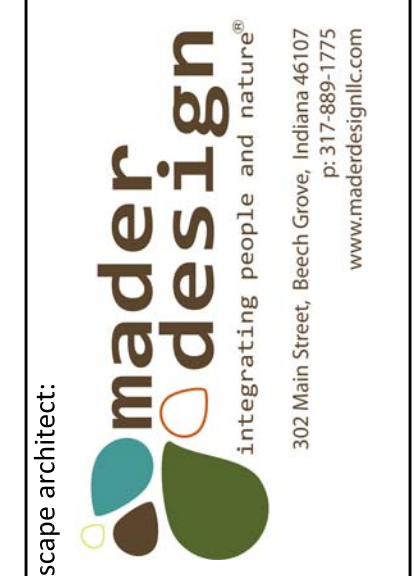

BLOOMINGTON PARKS
Griffy Lake Loop Trail - Dam Crossing
Bid Documents
3400 N. Healthy Road
Bloomington, Indiana 47408

Site Layout Plan
Dam

project: BLOOMINGTON PARKS Griffy Lake Loop Trail - Dam Crossing Bid Documents 3400 N. Healthy Road Bloomington, Indiana 47408

prepared for: CITY OF BLOOMINGTON

landscape architect: mader design

consultant: LANDWORK

date: 01.06.23
job #: 23-01
drawn by: KB
checked by: JM/JT

certified by: JEFFREY R. MADER, REGISTERED LANDSCAPE ARCHITECT, STATE OF INDIANA, LA20000264

revision: [table with 2 columns: no., description]

sheet number: L103

LAYOUT SCHEDULE

SYMBOL	DESCRIPTION	DETAIL
(L-01)	GRAVEL TRAIL SURFACE	1/L300
(L-02)	RIP-RAP	
(L-03)	WOOD FENCE: FOR BASE BID USE WOOD STAIR HANDRAIL DESIGN IN DETAIL 4/L300. FOR ALTERNATE #1 USE WOOD FENCE DESIGN SHOWN 7/L300	7/L300
(L-04)	REMOVABLE FENCE SECTION: INTENDED TO BE PERIODICALLY AND TEMPORARILY REMOVED FOR ACCESS BY DAM MAINTENANCE CREWS, AND EASILY REPLACED	
(L-05)	CHAIN LINK FENCE: 6' HEIGHT, WIRE FABRIC, POSTS AND BRACING TO MATCH EXISTING ADJACENT CHAIN LINK FENCE	
(L-06)	GATE: 4' WIDTH, MATCH CHAIN LINK FENCE	
(L-07)	WOOD DECK	5/L300
(L-08)	WOOD STAIRS	3/L300
(L-09)	WOOD STAIR HANDRAIL	4/L300
(L-10)	WOOD BENCH SEAT ON LANDING	6/L300
(L-11)	SAFETY SIGNAGE DIRECTING TRAIL USERS TO STAY ON DESIGNATED PATH; SIGN DESIGN AND VERBIAGE TO BE DETERMINED BY CITY OF BLOOMINGTON	
(L-12)	TRAIL RULES SIGN: VERBIAGE TO BE DETERMINED BY THE CITY OF BLOOMINGTON. RECOMMENDED 'SIGN TYPE H' FROM BLOOMINGTON PARKS AND RECREATION SIGN DESIGN MANUAL	
(L-13)	TIMBER BOLLARD	2/L300
(L-14)	COLLAPSIBLE BOLLARD: 'TRAFFIC GUARD' HINGED ROUND POST HRP48, OR APPROVED EQUAL	

ALTERNATE #1 - WOOD FENCE
BASE BID: PROVIDE WOOD FENCE TO MATCH WOOD STAIR HANDRAIL PER DETAIL 4/L300
ALTERNATE: PROVIDE WOOD FENCE PER DETAIL 7/L300

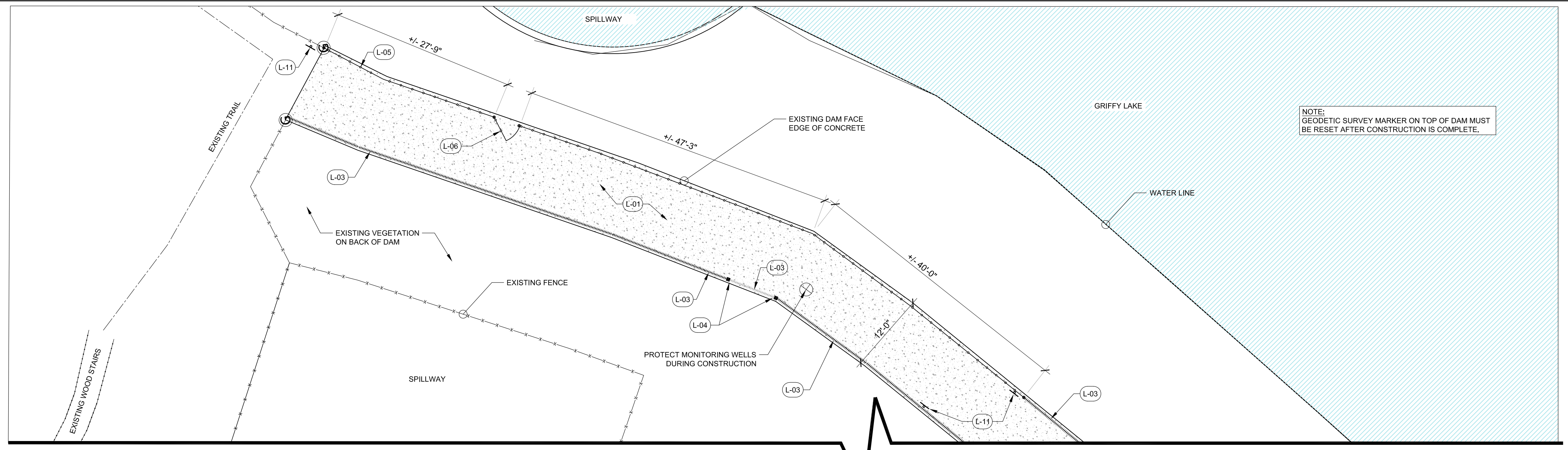

NOTE: GEODETIC SURVEY MARKER ON TOP OF DAM MUST BE RESET AFTER CONSTRUCTION IS COMPLETE.



landscape architect:



consultant:



prepared for:

BLOOMINGTON PARKS
Griffy Lake Loop Trail - Dam Crossing
Bid Documents
3400 N. Healdy Road
Bloomington, Indiana 47408

project:

description:

revision:



date: 01.06.23
job #:
drawn by: KB
checked by: JM/JT

Sheet number:

L104

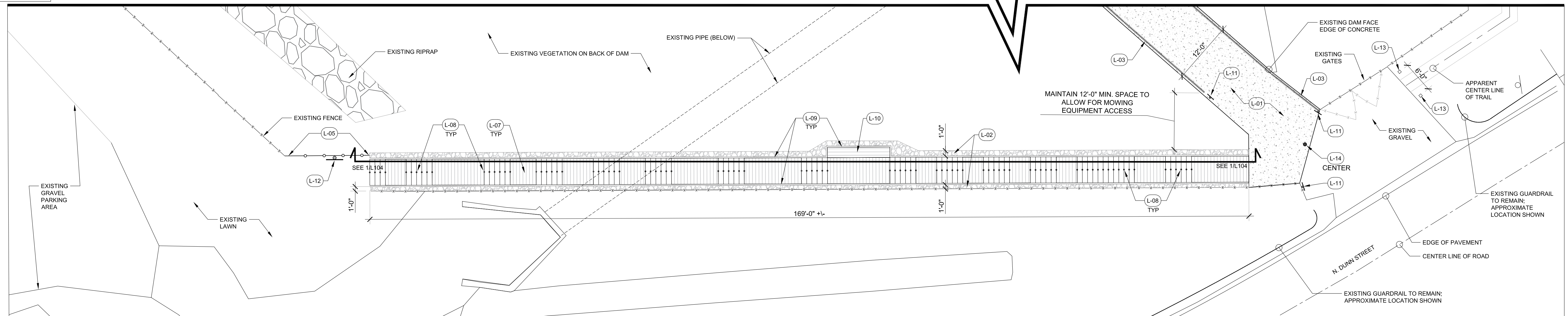

2 DAM CROSSING AND STAIRS - LAYOUT PLAN

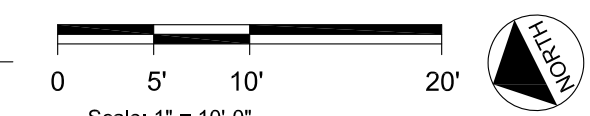

GENERAL SITE LAYOUT NOTES

- ALL TOPOGRAPHIC AND SURVEY INFORMATION HAS BEEN OBTAINED FROM BLEDSE RIGGERT COOPER JAMES, DATED JANUARY 2020. LANDSCAPE ARCHITECT CLAIMS NO RESPONSIBILITY FOR ACCURACY OF INFORMATION PROVIDED. VERIFY AND CONFIRM ALL EXISTING CONDITIONS PRIOR TO CONSTRUCTION.
- LOCATE AND VERIFY ALL PUBLIC AND PRIVATE UTILITIES PRIOR TO STARTING WORK.
- STAKE AND CONFIRM ALL DIMENSIONS AND GRADES PRIOR TO STARTING WORK. REPORT ANY DISCREPANCIES TO OWNERS REPRESENTATIVE IMMEDIATELY. DRAWINGS SHALL NOT BE SCALED FOR LAYOUT PURPOSES.
- PROVIDE SMOOTH TRANSITION FROM NEW AREAS TO EXISTING FEATURES AS NECESSARY.
- WHERE NEW PAVEMENT IS SHOWN TO MEET EXISTING, SAW CUT EXISTING PAVEMENT VERTICALLY. REMOVE DELETERIOUS MATERIAL, AND PREPARE FOR NEW WORK.
- ALL AREAS WHERE PROPOSED ASPHALT PAVEMENT MEETS THE EXISTING PAVEMENT THE EXISTING PAVEMENT EDGE SHALL BE SAW CUT VERTICALLY AND PROPERLY SEALED WITH A TACK COAT MATERIAL.
- ALL DIMENSIONS IN CURBED AREAS SHALL BE TO FACE OF CURB. ALL DIMENSIONS IN AREAS WITHOUT CURBING SHALL BE TO EDGE OF PAVEMENT. ALL DIMENSIONS AT INTERSECTIONS AND WALKS SHALL BE TO FACE OF CURB. ALL DIMENSIONS FROM BUILDING SHALL BE FROM FACE OF BUILDING.
- ALL DIMENSIONS ARE PARALLEL AND PERPENDICULAR TO BASE LINES, PROPERTY LINES OR BUILDING LINES UNLESS OTHERWISE NOTED.
- ALL RADII INDICATED SHALL BE FORMED AS CIRCULAR ARCS. ALL CURBS AND ARCS SHALL INTERSECT OTHER CURBS AND LINES AT POINTS OF TANGENCY TO FORM SMOOTH TRANSITIONS UNLESS CLEARLY SHOWN OTHERWISE.
- RADII SHALL BE 5'-0" ON PARKING LOTS, CONCRETE WALKS AND ASPHALT TRAILS UNLESS OTHERWISE NOTED OR WHERE DRAWING APPEARS SIGNIFICANTLY DIFFERENT.
- WHERE NOT SHOWN, CONCRETE SIDEWALK AND RETAINING WALL EXPANSION JOINTS SHALL BE 30'-0" O.C. AND CONTROL JOINTS 5'-0" O.C. MAX. CURB EXPANSION JOINTS SHALL BE 50'-0" O.C. MAX AND AT ALL 90 DEGREE ANGLES. CONTROL JOINTS SHALL ALIGN WITH ADJACENT SIDEWALK WHERE APPLICABLE. OTHERWISE 10'-0" MAXIMUM SPACING SHALL BE USED.
- ACCESSIBLE RAMPS AND SIGNAGE SHALL BE IN ACCORDANCE WITH FEDERAL, STATE, COUNTY, CITY AND LOCAL CODES (WHICHEVER HAS JURISDICTION). SEE SITE PLANS FOR LOCATIONS AND SITE DETAILS FOR SPECIFICATIONS.
- SEED ALL AREAS DISTURBED BY CONSTRUCTION ACTIVITIES AND NOT CALLED OUT TO BE PAVED OR PLANTED WITH OTHER PLANT MATERIAL.
- CONTRACTOR SHALL OBTAIN ALL PERMITS AND COORDINATE WITH LOCAL REGULATORY AGENCIES AS REQUIRED BY LOCAL JURISDICTIONS.

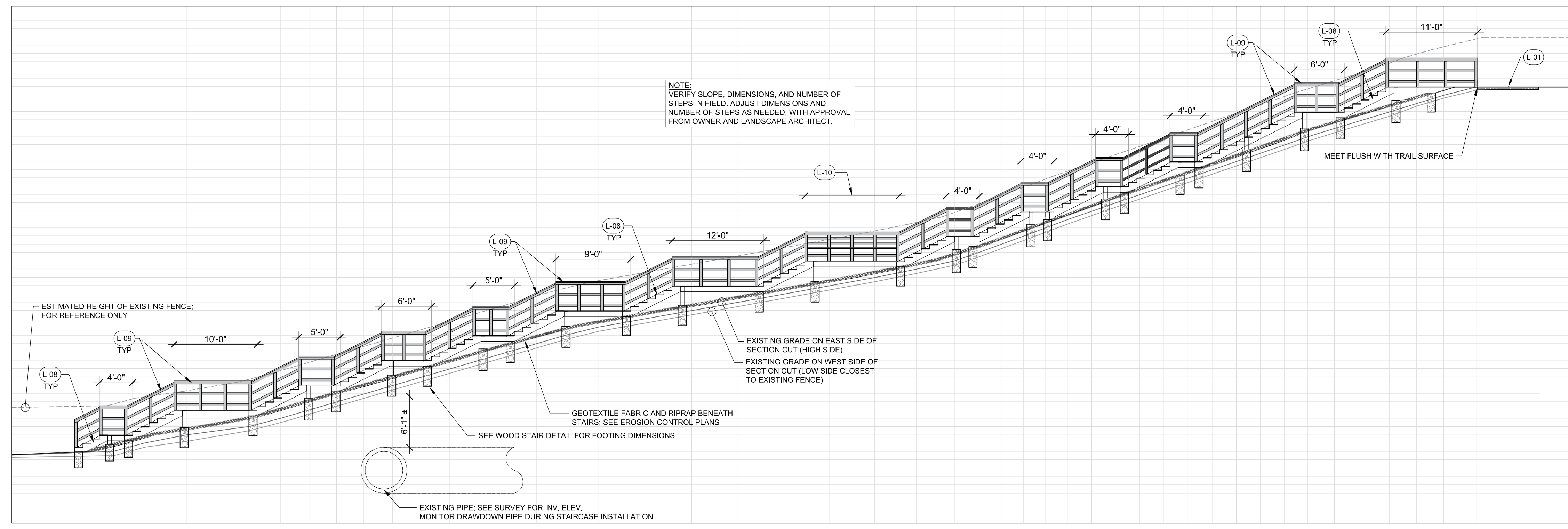

1 DAM STAIRS - SECTION DRAWING

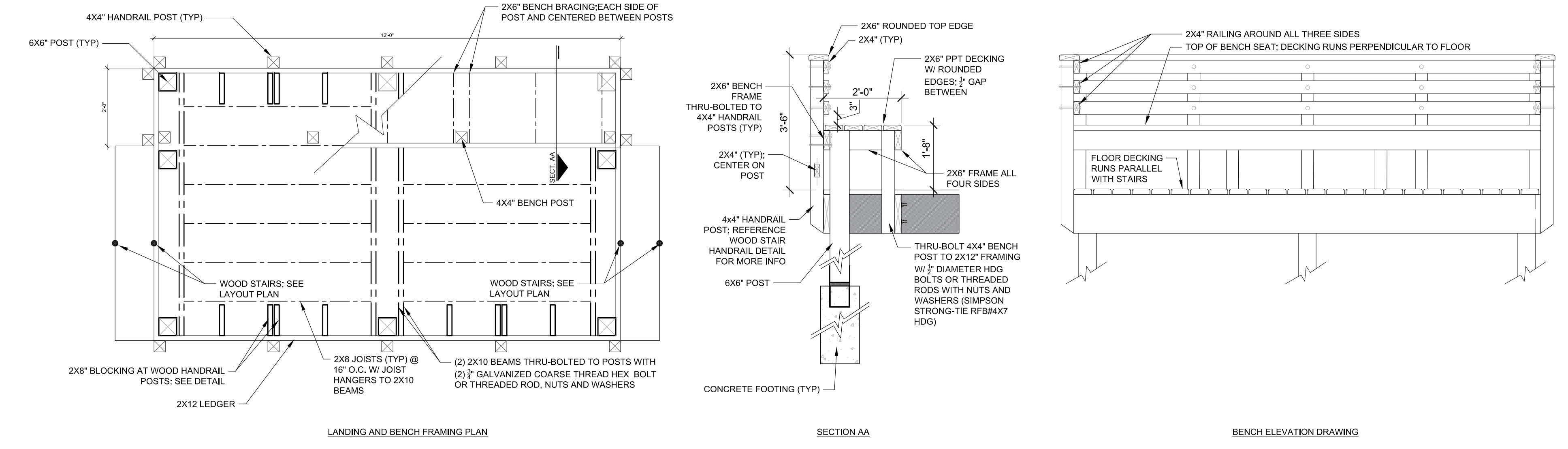

6 WOOD BENCH SEAT ON LANDING
1/2" = 1'-0"

P-DAM-95

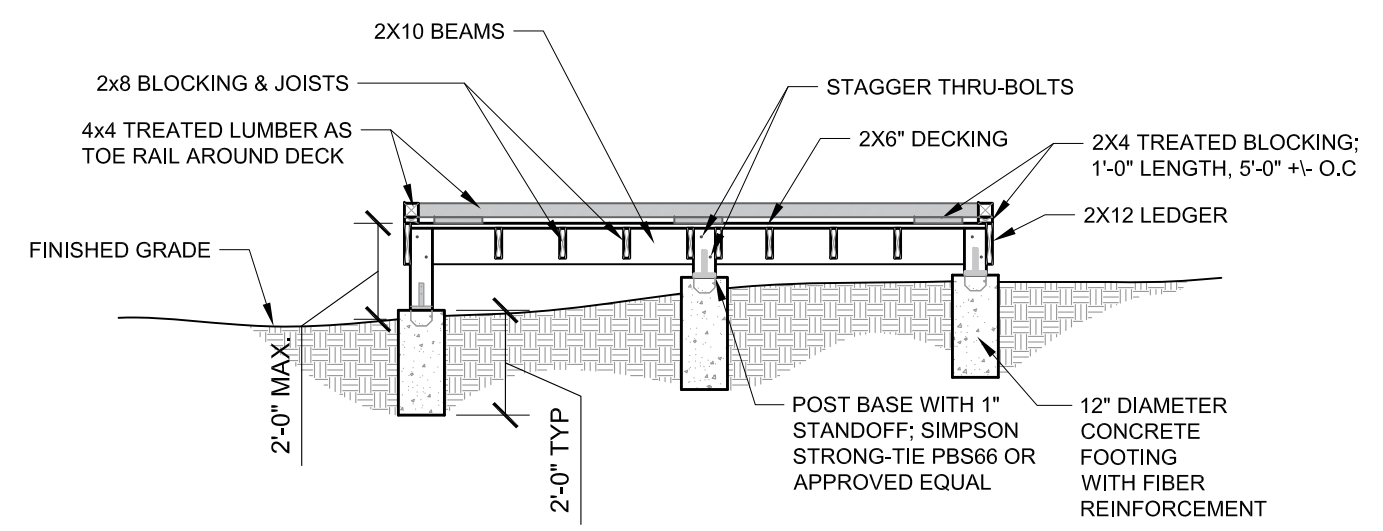

5 WOOD DECK TYPICAL SECTION
1/4" = 1'-0"

P-DAM-99

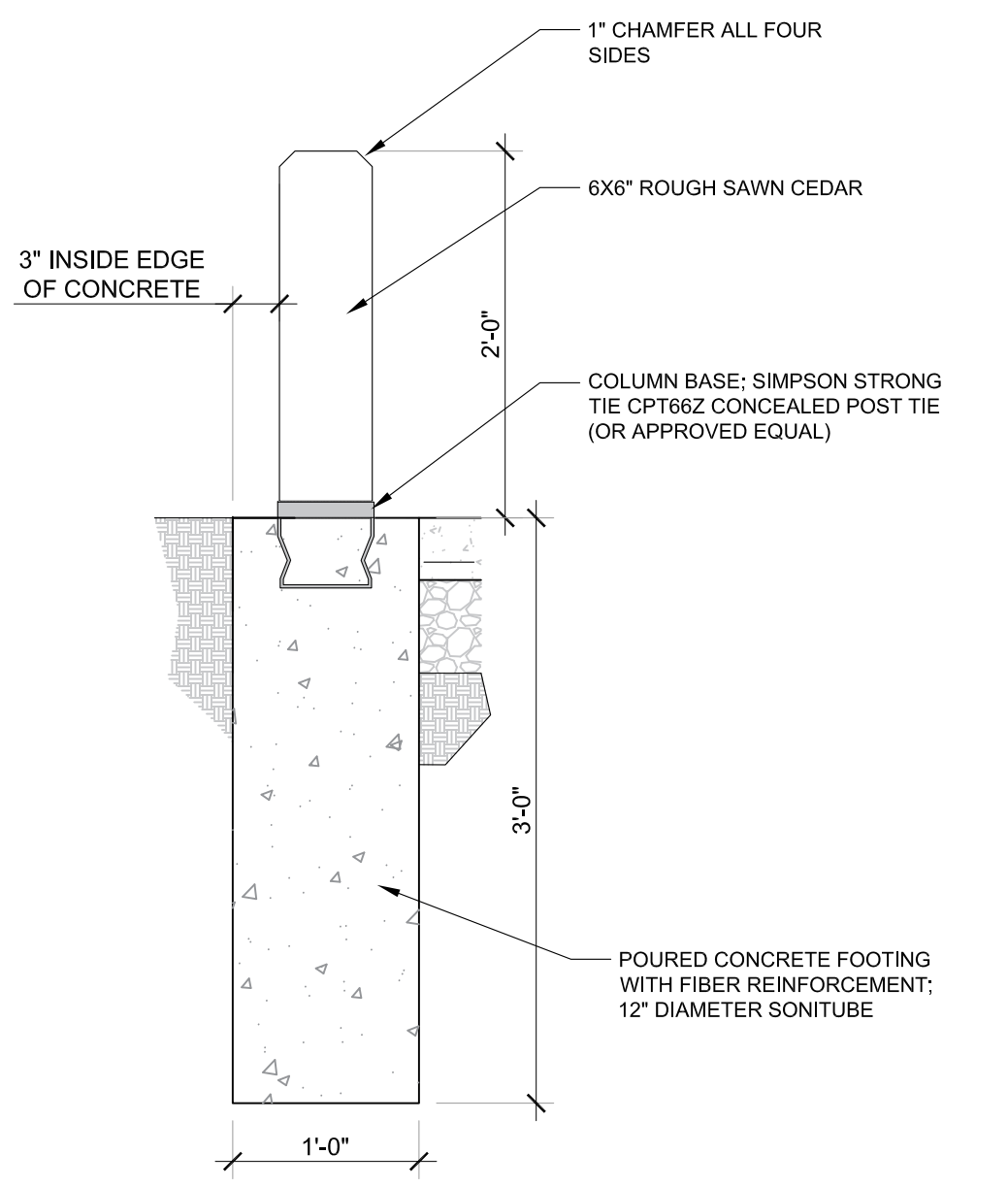

2 TIMBER BOLLARD
NTS

P-DAM-84

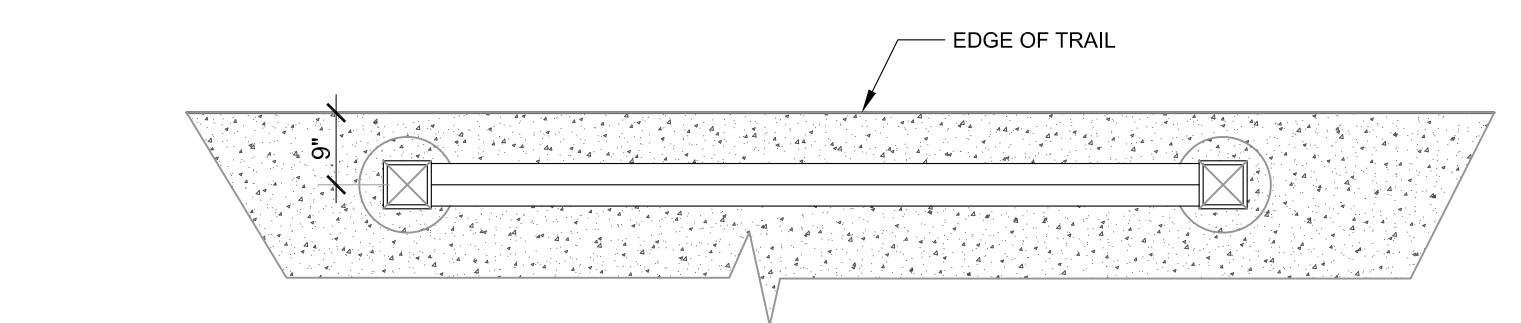

4 WOOD STAIR HANDRAIL
1/2" = 1'-0"

P-DAM-89

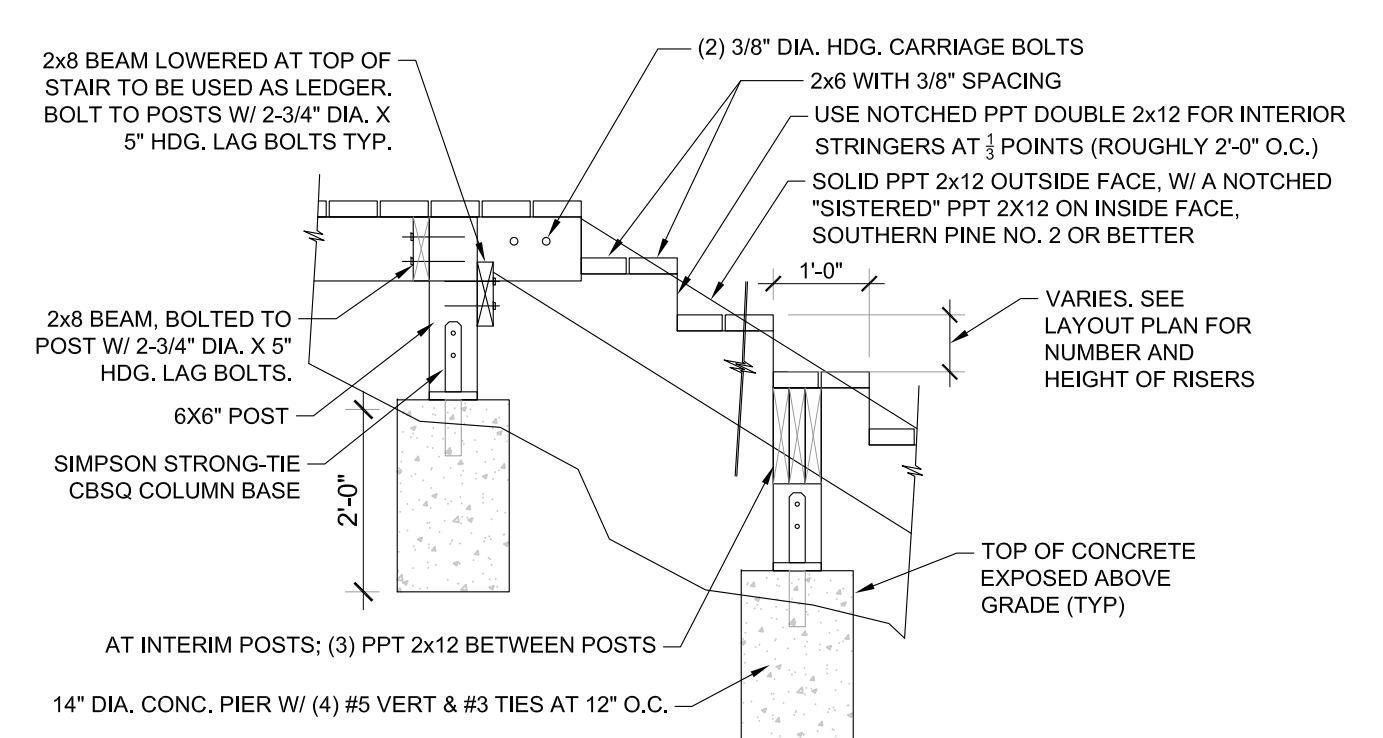

3 WOOD STAIR
1/2" = 1'-0"

P-DAM-88

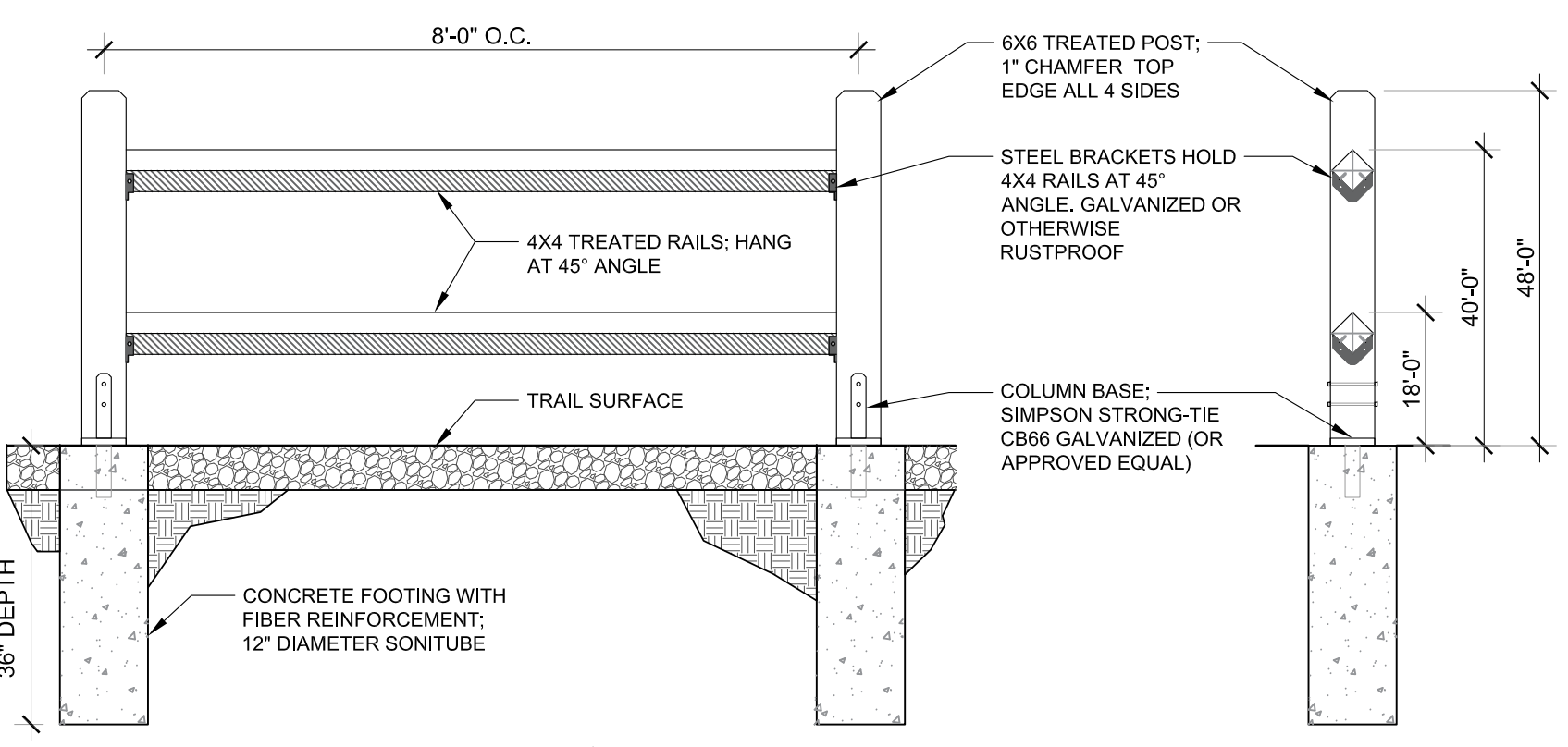

7 WOOD FENCE
1/2" = 1'-0"

P-DAM-100

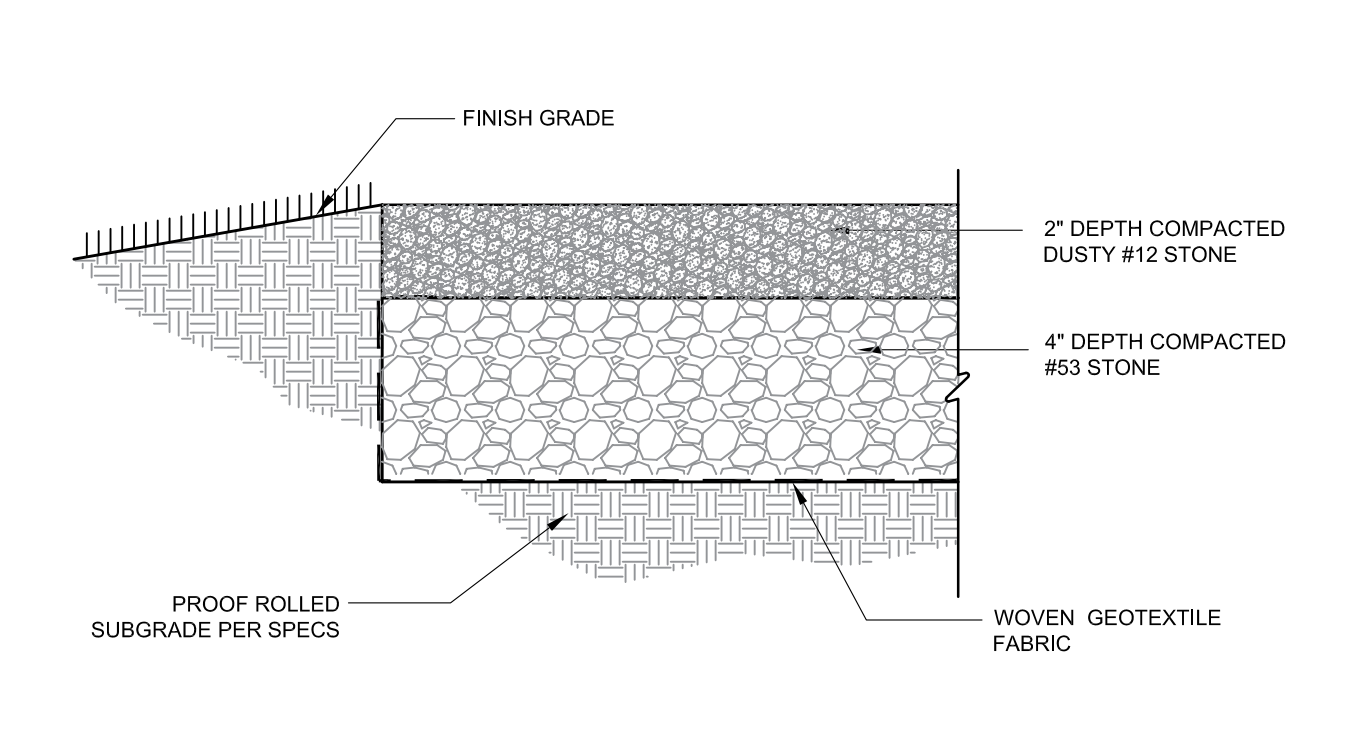

1 GRAVEL TRAIL
NTS

P-DAM-05

project: **BLOOMINGTON PARKS**
Griffy Lake Loop Trail - Dam Crossing
Bid Documents
3400 N. Aberdeen Road
Bloomington, Indiana 47408

prepared for: **CITY OF BLOOMINGTON**

landscape architect: **mader design**

consultant: **LANDWORX**

Site Details



date: 01.06.23
drawn by: KB
checked by: JMJ/T

Sheet number: **L300**

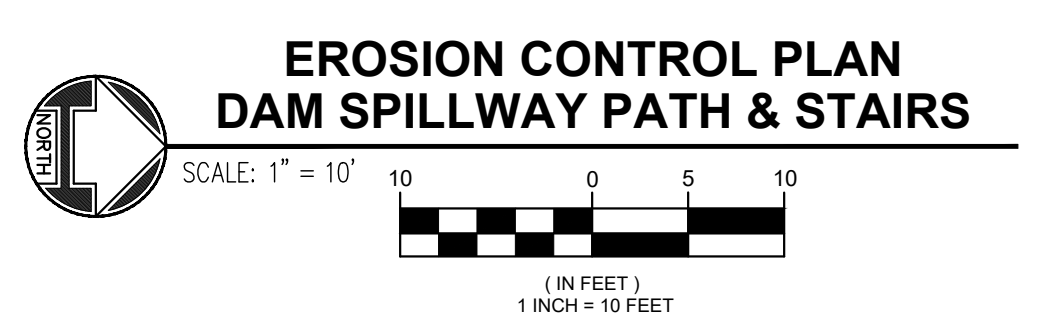
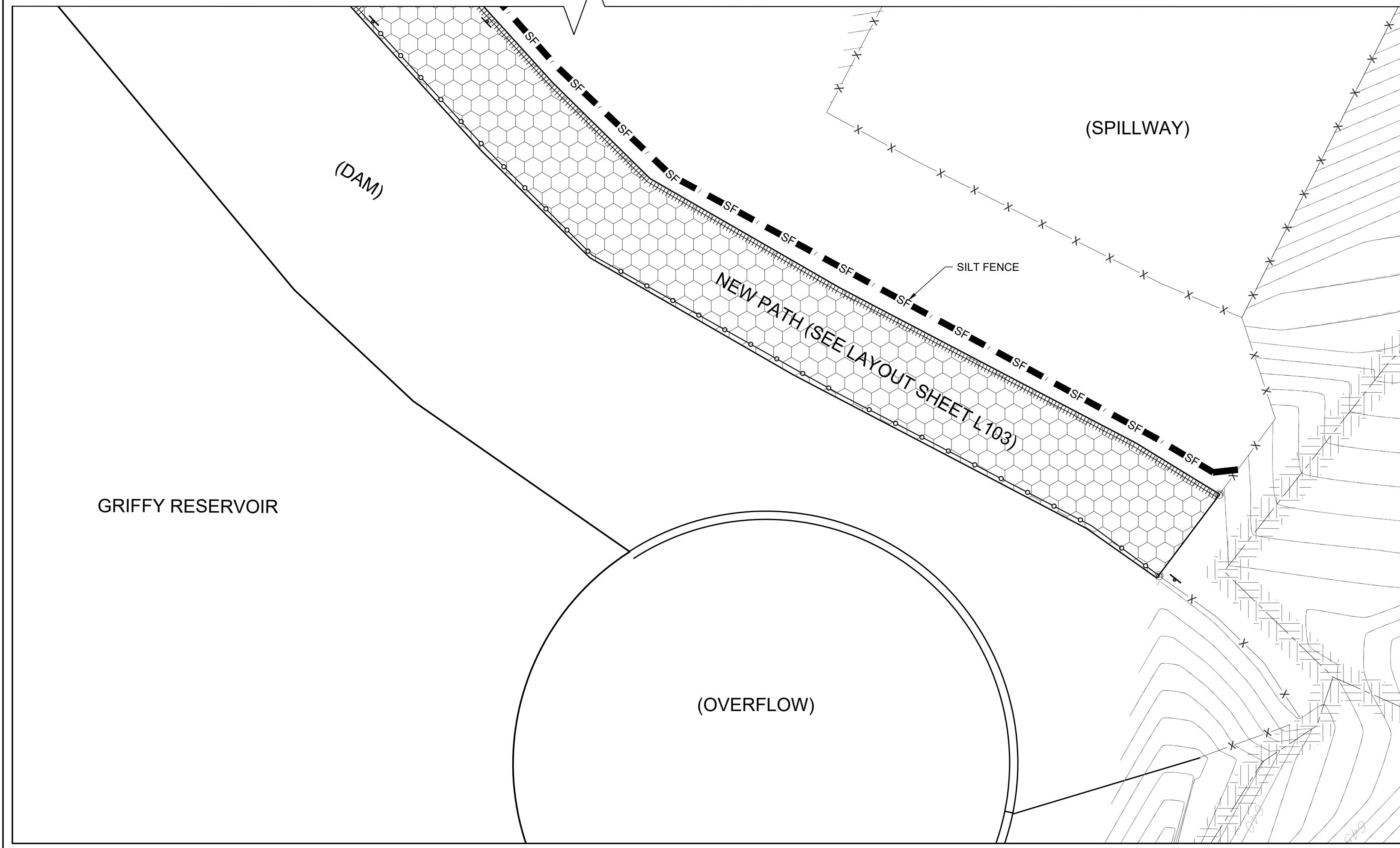
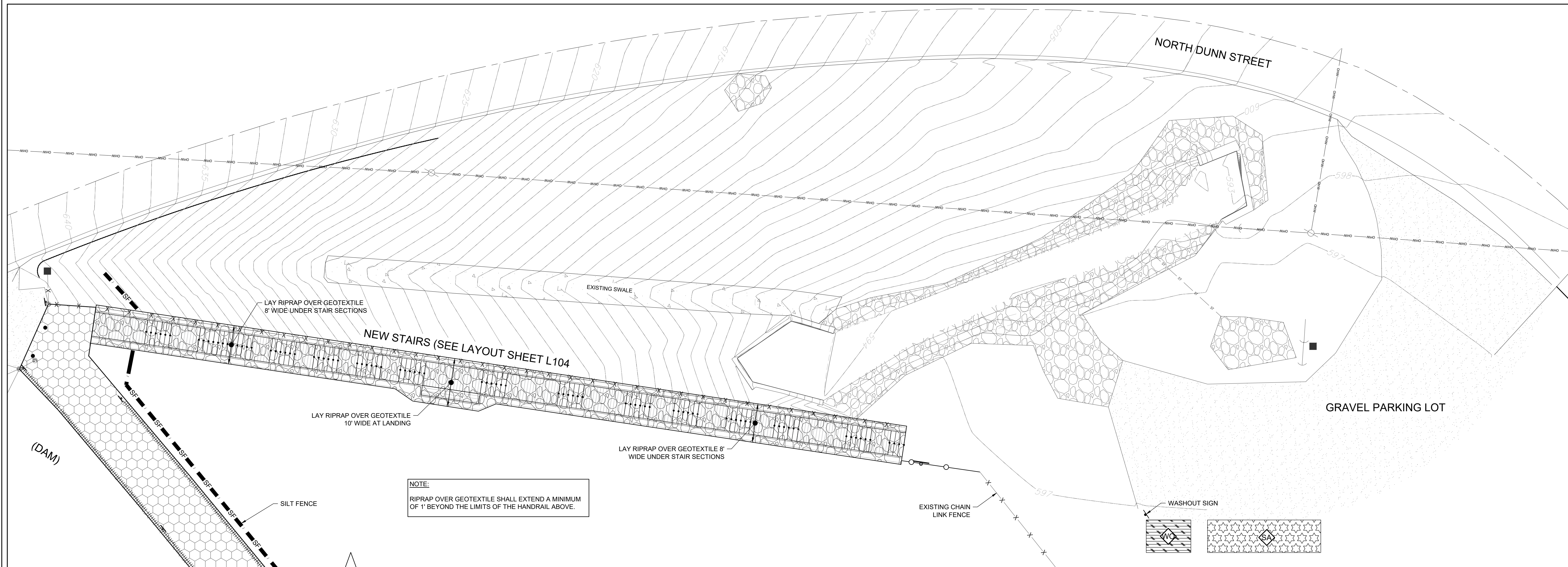

EROSION CONTROL LEGEND:	
DESCRIPTION & CALL SYMBOL:	DETAIL #/SH. #
SILT FENCE (SF)	DETAIL 05/C420
RIPRAP OVER GEOTEXTILE (RG)	DETAIL 01/C420
CONCRETE WASHOUT (WC)	DETAIL 03/C420
STAGING AREA (SA)	

landscape architect:
mader design
Integrating people and nature®
302 Main Street, Beech Grove, Indiana 46107
www.maderdesignllc.com

consultant:
LANDWORX

prepared for:
CITY OF BLOOMINGTON

project:
BLOOMINGTON PARKS
Griffy Lake Loop Trail - Dam Crossing
Bid Documents
3400 N. Maple Hill Road
Bloomington, Indiana 47408

revision:	description:	date:

certified by:
BENJAMIN J. MOUL
REGISTERED PROFESSIONAL ENGINEER
No. PE10708282
STATE OF INDIANA
12/2023

date: 1.6.2023
job #: LW0108
drawn by: MDC
checked by: BHM

Landscape Architect is the author and owner of these drawings and specifications. They shall be used solely for the purposes of this project and shall not be used for any other Project or Work without express permission of the Landscape Architect.
sheet number:
C401

NOTE:
DETAILS IN THIS SECTION ARE TO BE USED AS NEEDED.

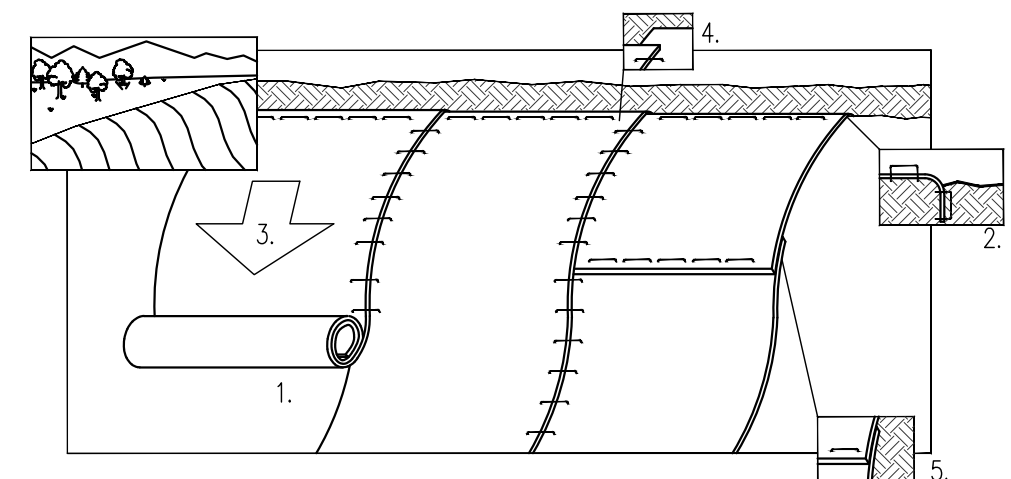

1. Prepare soil before installing blankets, including application of lime, fertilizer, and seed.
2. Begin at the top of the slope by anchoring the blanket in a 6" deep x 6" wide trench. Backfill and compact the trench after stapling.
3. Roll the blankets down the slope in the direction of the water flow.
4. The edges of parallel blankets must be stapled with approximately 2" overlap.
5. When blankets must be spliced down the slope, place blankets end over end (shingle style) with approximately 6" overlap, staple through overlapped area, approx. 12" apart.

REFER TO GENERAL STAPLE PATTERN GUIDE 07/C410 FOR CORRECT STAPLE PATTERN RECOMMENDATIONS.

BLANKETS SHALL BE MADE OF NATURAL MATERIAL SUCH AS COTTON, JUTE, OR OTHER NATURAL FIBERS

06 SLOPE INSTALLATION GUIDE
NO SCALE

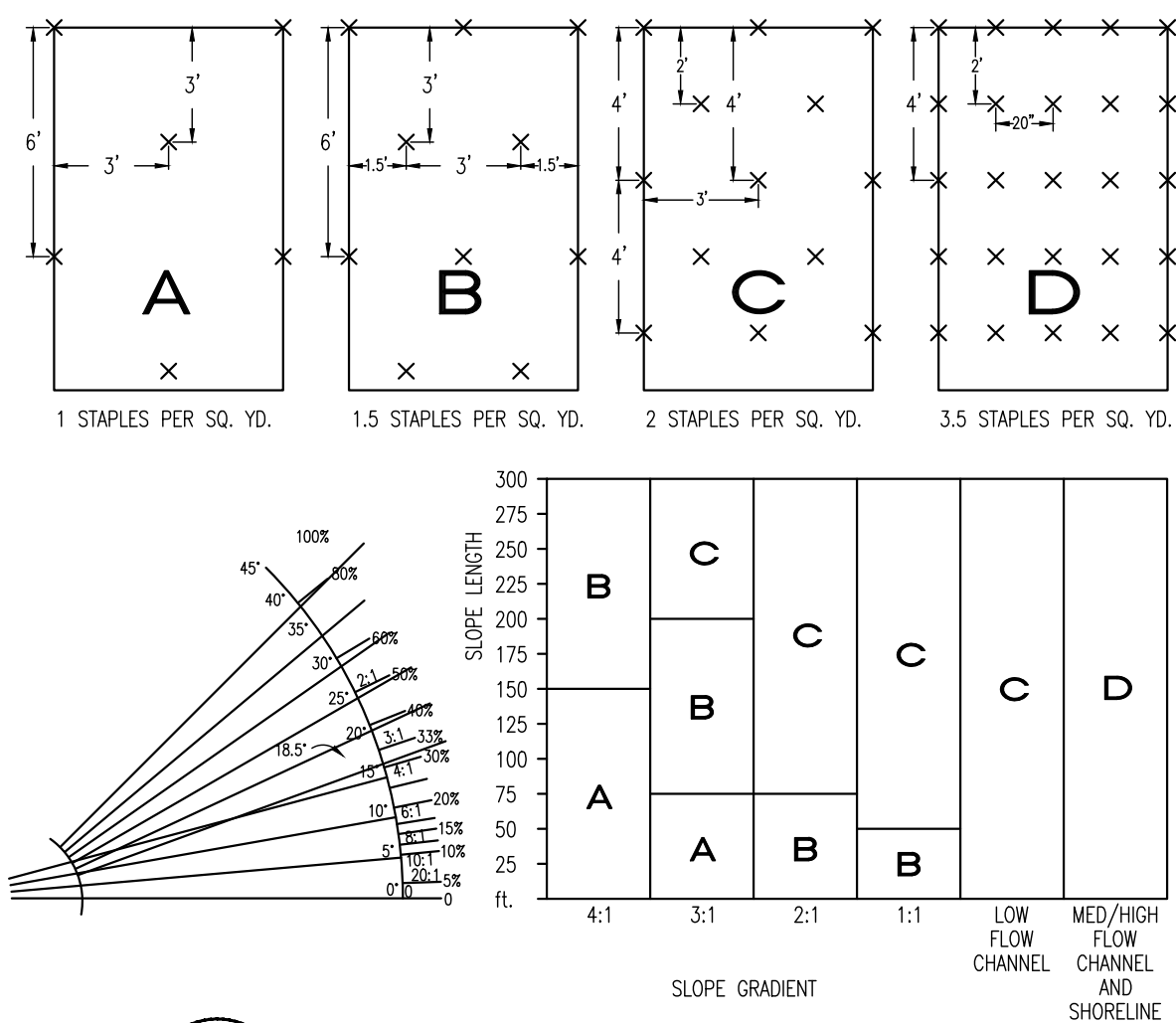

07 STAPLE PATTERN GUIDE
NO SCALE

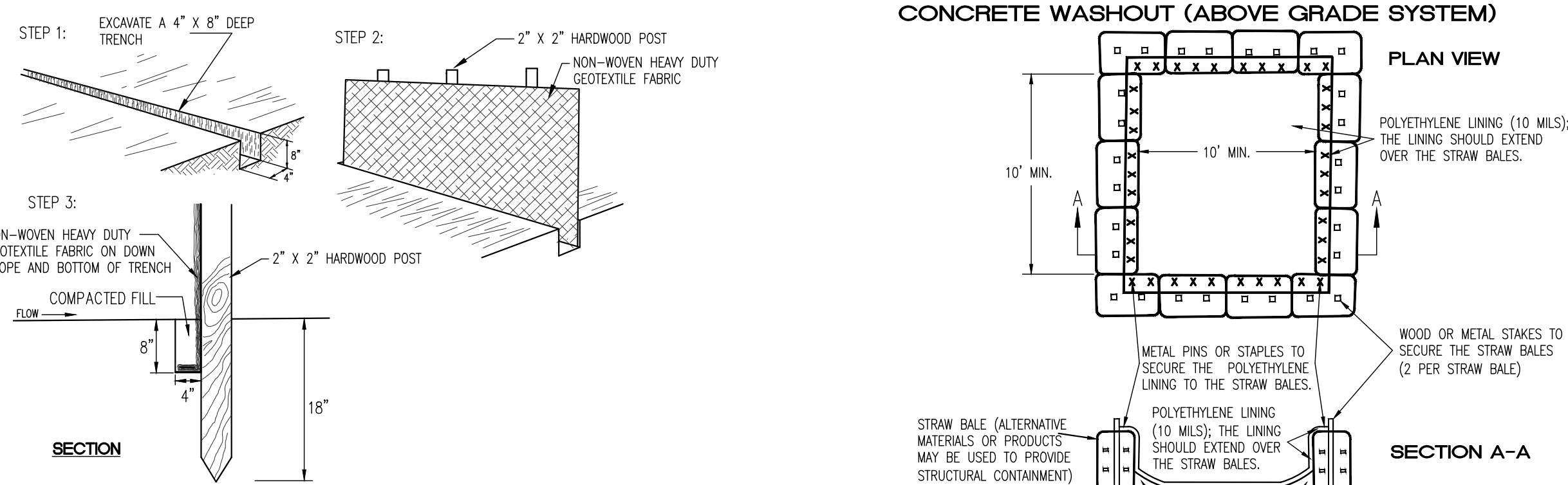

- Installation:**
- Prefabricated Washout Systems/Containers
 - Install and locate according to the manufacturer's recommendations.
 - Designed and Installed Systems
 - Utilize and follow the design in the storm water pollution prevention plan to install the system.
 - Dependent upon the type of system, either excavate the pit or install the containment system.
 - A base shall be constructed and prepared that is free of rocks and other debris that may cause tears or punctures in the polyethylene lining.
 - Install the polyethylene lining. For excavated systems, the lining should extend over the entire excavation. The lining for bermed systems should be installed over the pooling area with enough material to extend the lining over the berm or containment system. The lining should be secured with pins, staples, or other fasteners.
 - Place flags, safety fencing, or equivalent to provide a barrier to construction equipment and other traffic.
 - Place a non-collapsing, non-water holding cover over the washout facility prior to a predicted rainfall event to prevent accumulation of water and possible overflow of the system (optional).
 - Install signage that identifies concrete washout areas (See Washout Sign Detail 04/C410).
 - Post signs directing contractors and suppliers to designated locations (See Washout Sign locations on sheet C400).
 - Where necessary, provide stable ingress and egress or alternative approach pad for concrete washout systems.

- Maintenance:**
- Inspect daily and after each storm event.
 - Inspect the integrity of the overall structure including, where applicable, the containment system.
 - Inspect the system for leaks, spills, and tracking of soil by equipment.
 - Inspect the polyethylene lining for failure, including tears and punctures.
 - Once concrete wastes harden, remove and dispose of the material.
 - Excess concrete should be removed when the washout system reaches 50 percent of the design capacity. Use of the system should be discontinued until appropriate measures can be initiated to clean the structure. Prefabricated systems should also utilize this criterion, unless the manufacturer has alternate specifications.
 - Upon removal of the solids, inspect the structure. Repair the structure as needed or construct a new system.
 - Dispose of all concrete in a legal manner. Reuse the material on site, recycle, or haul the material to an approved construction/demolition landfill site. Recycling of material is encouraged. The waste material can be used for multiple applications including but not limited to roadbeds and building. The availability for recycling should be checked locally.
 - The plastic liner should be replaced after every cleaning; the removal of material will usually damage the lining.
 - The concrete washout system should be repaired or enlarged as necessary to maintain capacity for concrete waste.
 - Concrete washout systems are designed to promote evaporation. However, if the liquids do not evaporate and the system is near capacity it may be necessary to vacuum or remove the liquids and dispose of them in an acceptable method. Disposal may be allowed at the local sanitary sewer authority provided their National Pollutant Discharge Elimination System permits allow for acceptance of this material. Another option would be to utilize a secondary containment system or basin for further dewatering.
 - Prefabricated units are often pumped and the company supplying the unit provides this service.
 - Inspect construction activities on a regular basis to ensure suppliers, contractors, and others are utilizing designated washout areas. If concrete waste is being disposed of improperly, identify the violators and take appropriate action.
 - When concrete washout systems are no longer required, the concrete washout systems shall be closed. Dispose of all hardened concrete and other materials used to construct the system.
 - Holes, depressions and other land disturbances associated with the system should be backfilled, graded, and stabilized.

05 SILT FENCE BARRIER INSTALLATION
NO SCALE

03 CONCRETE WASHOUT DETAIL
NO SCALE

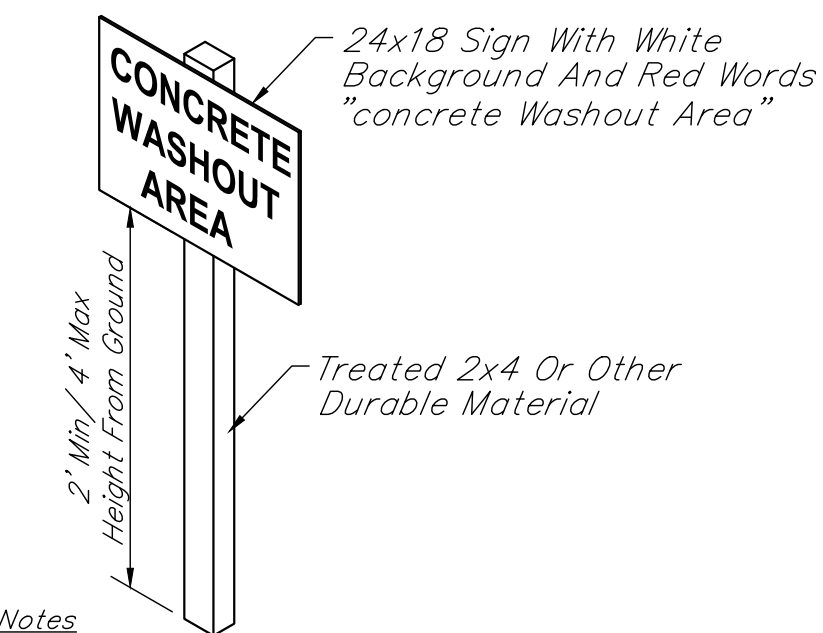

- Notes:**
1. Sign post shall be imbedded in the ground 1/3 of the length of the post.
 2. Sign shall be posted at the entrance of the parking lot at Headley Road where the washout is located and be visible from both directions.
 3. One sign shall be located adjacent to the washout clearly visible from the signs along Headley Road.
 4. Signage shall be in place during the entire construction timeline.
 5. Contractor shall inspect the sign for damage routinely and after storms or high winds. The Contractor shall replace/repair damaged or missing as needed.

04 CONCRETE WASHOUT SIGN
NO SCALE

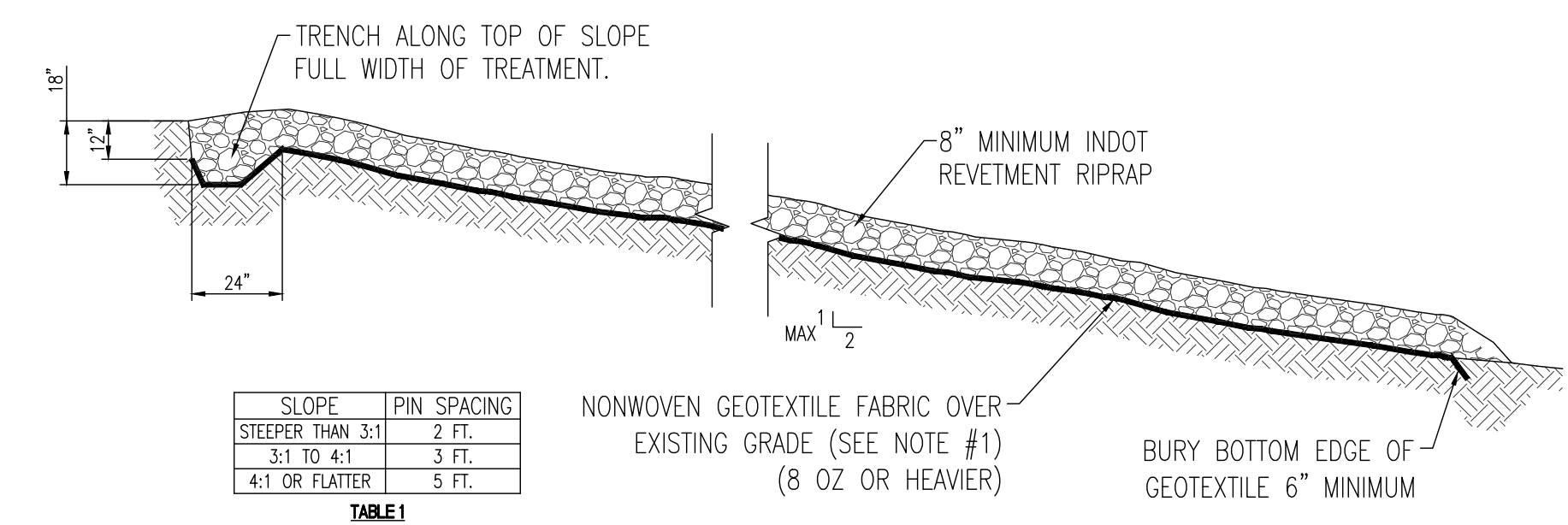

- NOTES:**
1. The area shall be graded and debris removed to provide a smooth, fairly-even surface.
 2. Geotextile shall be placed loosely, laid with the machine (generally roll) direction, in the same direction as anticipated water flow or movement.
 3. Adjacent pieces of geotextile may be joined by sewing, or by overlapping and pinning. The minimum overlap shall be 18 in.
 4. Securing pins shall be steel, 3/16 in. in diameter, 18 in. long, pointed at one end and fabricated with a head to retain a steel washer having an outside diameter of no less than 1 1/2 in. Securing pins with washers shall be inserted through both strips of overlapped geotextile at spacing intervals in Table 1 along a line through the midpoint of the overlap. The geotextile strip shall be placed so that the lower strip will be overlapped by the next higher strip. Pins shall be driven until the washer bears against the geotextile and secures it firmly to the ground.
 5. The geotextile shall be placed in such a manner that placement of the overlying materials will not excessively stretch or tear the geotextile and will not pull the required overlap or seam apart.
 6. The contractor shall ensure that the geotextile is entirely covered and no portions are left exposed to sunlight.
 7. Construction equipment shall not be on the exposed geotextile.
 8. Placement of riprap or stone shall start from the base of the slope, moving up slope and from the center outward. Riprap shall not roll downslope and the height of drop for riprap shall be kept to less than 2 ft.

01 RIPRAP OVER GEOTEXTILE UNDER STAIR TREATMENT
NO SCALE

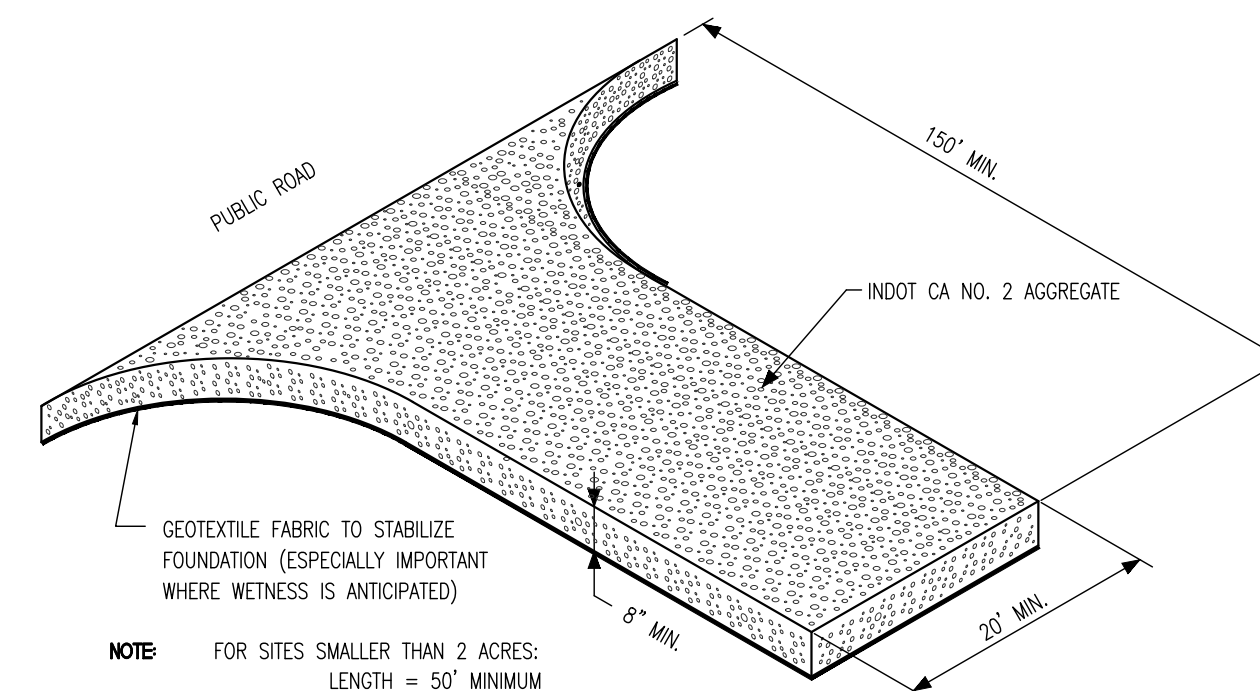

NOTE: FOR SITES SMALLER THAN 2 ACRES:
LENGTH = 50' MINIMUM
WIDTH = 12' MINIMUM
THICKNESS = 6" MINIMUM

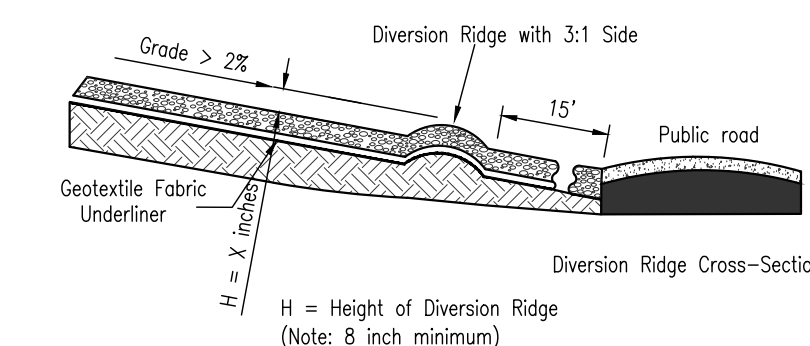

- Installation:**
1. Remove all vegetation and other objectionable material from the foundation area.
 2. Grade foundation and crown for positive drainage. If the slope of the construction entrance is toward a public road and exceeds two percent, construct an eight inch high diversion ridge with a ratio of 3-to-1 side slopes across the foundation area about 15 feet from the entrance to divert runoff away from the road.
 3. Install a culvert pipe under the pad if needed to maintain proper public road drainage.
 4. If wet conditions are anticipated, place geotextile fabric on the graded foundation to improve stability.
 5. Place aggregate (INDOT CA No. 2) to the dimensions and grade shown in the construction plans, leaving the surface smooth and sloped for drainage.
 6. Top-dress the first 50 feet adjacent to the public roadway with two to three inches of washed aggregate (INDOT CA NO. 53) [optional, used primarily where the purpose of the pad is keep soil from adhering to vehicle tires]
 7. Where possible, divert all storm water runoff and drainage from the ingress/egress pad to a sediment trap or basin.

- Maintenance:**
- Inspect daily.
 - Reshape pad as needed for drainage and runoff control.
 - Top dress with clean aggregate as needed.
 - Immediately remove mud and sediment tracked or washed onto public roads.
 - Flushing should only be used if the water can be conveyed into a sediment trap or basin.

02 TEMPORARY CONSTRUCTION INGRESS / EGRESS PAD
NO SCALE

landscape architect:
mader design
Integrating people and nature®
302 Main Street, Beech Grove, Indiana 46107
www.maderdesignllc.com

consultant:
LANDWORK

prepared for:
CITY OF BLOOMINGTON

project:
**BLOOMINGTON PARKS
Griffy Lake Loop Trail - Dam Crossing
Bid Documents**
3400 N. Appleton Road
Bloomington, Indiana 47408

Griffy Lake Dam
Erosion Control Details

date:	description:

engineer:
BENJAMIN J. MOULDER
REGISTERED
No. PE10708282
STATE OF INDIANA
PROFESSIONAL ENGINEER
5/7/2023

date: 1.6.2023
job #: LW0108
drawn by: MDC
checked by: BHM

Landscape Architect is the author and owner of these drawings and specifications. They shall be used solely for the purposes of this project and shall not be used for any other Project or Work without express permission of the Landscape Architect.

sheet number:

C410

City of Bloomington
Redevelopment Commission
Amended Project Review & Approval Form

Please Note:

- Approval of the project by the Redevelopment Commission through this Project Review & Approval Form does not represent an authorization to begin work or expend funds.
- Authorization of work and the commitment of funds shall be done when the Redevelopment Commission reviews and approves: (1) a Purchase Order or Contract prepared after complying with the appropriate procurement process for the type of item, service or construction being sought and (2) the estimated costs associated with the Purchase Order or Contract.
- No payment of funds shall be made without a duly authorized and approved Purchase Order or Contract. All claims for payment against a duly authorized Purchase Order or Contract shall be submitted to the Redevelopment Commission for their review and approval along with any required departmental inspections, reviews and approvals prior to the payment of any funds.

To Be Completed by Requesting Party:

Project Name: Griffy Loop Trail Dam Crossing

Project Manager: Tim Street, Parks Operation and Development Director

Project Description: A recent project at Griffy Lake Nature Preserve constructed a new pedestrian trail and fishing pier along the west side of Headley Rd along with new hiking trail on the south shore of Griffy Lake. These improvements are a significant portion of the overall planned Griffy Loop Trail improvements. Safety and access improvements to the trail crossing of the dam were also planned but were value engineered out of the project after bids were received. This project would complete the safety and access improvements to the trail at the Griffy Dam, formalizing the crossing with a quarter minus path along the top of the dam that more fluidly connects with hiking trails to the south and north. It would also install necessary safety signage and fencing and create a new staircase to improve access to the trail from the dam parking lot. Since this was already designed, this project is shovel-ready and already permitted through DNR.

Project Timeline: Finalize design & bid – late 2022
Construction – spring/summer 2023

Financial Information:

Estimated full cost of project:	\$375,000
Sources of funds:	TIF Funds
	<i>Reimbursed from 2022 Parks Bond as funds are available.</i>

Project Phases:

<u>Phase/Work to Be Performed</u>	<u>Cost</u>	<u>Timeline</u>
1. Finalize Design and Bid Documents Agreement with Mader Design	\$12,500	Fall/Winter 2022
2. Bid Construction Project & Build Agreement with Scenic Construction Svcs	\$362,500 \$344,700	Spring/Summer 2023

TIF Districts: North Kinser/Prow Rd TIF; Consolidated TIF (W. 17th Street)

Resolution History: 22-63: Project Review and Approval Form
22-67: Approval of Construction Administration Agreement
23-28: Approval of Construction Agreement

To Be Completed by Redevelopment Commission Staff:

Approved on _____

By Resolution _____ by a vote of _____

23-29
RESOLUTION
OF THE
REDEVELOPMENT COMMISSION
OF THE
CITY OF BLOOMINGTON, INDIANA

**APPROVAL OF PROJECT REVIEW AND APPROVAL FORM FOR A REGIONAL
ECONOMIC ACCELERATION AND DEVELOPMENT INITIATIVE (READI) GRANT FOR
HOPEWELL**

WHEREAS, pursuant to Indiana Code 36-7-14 *et seq.*, the Redevelopment Commission of the City of Bloomington (“RDC”) and the Common Council of the City of Bloomington created an economic development area known as the Consolidated Economic Development Area (“Consolidated TIF”); and

WHEREAS, in Resolution 23-04, the RDC approved a Project Review and Approval Form (“Form”) which sought the support of the RDC to provide matching funds for the Regional Economic Acceleration and Development Initiative (READI) Grant for the construction of Jackson Street in the Hopewell redevelopment area (“Project”); and

WHEREAS, the City was awarded a READI grant in the amount of \$1,800,000.00 for the Project; and

WHEREAS, a copy of the Agreement for the READI grant is attached to this Resolution as Exhibit A (“Agreement”); and

WHEREAS, the Agreement does not include any award of a construction or design contract, and those subsequent agreements will be brought separately to the RDC; and

WHEREAS, a copy of the Amended Project Review Form (“Amended Form”) is attached to this Resolution as Exhibit B;

NOW, THEREFORE, BE IT RESOLVED BY THE REDEVELOPMENT COMMISSION OF THE CITY OF BLOOMINGTON, INDIANA, THAT:

1. The RDC reaffirms its support of the Project, as set forth in the Amended Form, and reiterates that it serves the public’s best interests.
2. The RDC finds the Project is an appropriate use of TIF, and that the Project serves the public’s best interests.
3. The RDC hereby approves the Agreement for the READI grant attached and incorporated into this Resolution as Exhibit A.

BLOOMINGTON REDEVELOPMENT COMMISSION

Cindy Kinnarney, President

ATTEST:

Deborah Myerson, Secretary

Date

REGIONAL ECONOMIC ACCELERATION AND DEVELOPMENT INITIATIVE GRANT

CONTRACTOR AGREEMENT

THIS CONTRACTOR AGREEMENT (“**Agreement**”) is entered into as of March ____, 2023 (“**Effective Date**”), by and between the **REGIONAL OPPORTUNITY INITIATIVES, INC.** (“**ROI**”) and the **CITY OF BLOOMINGTON, INDIANA** (“**Contractor**”).

WHEREAS, ROI has entered into a Grant Agreement with the Indiana Economic Development Corporation (the “**IEDC**”) (the “**Grant Agreement**”), attached hereto as **Exhibit A**, for the purposes of administering the Coronavirus State Fiscal Recovery Funds that ROI receives from the federal government (“**Funds**”).

WHEREAS, ROI has contracted with Contractor to perform the work described in Contractor’s Consolidated Project Report, attached hereto as **Exhibit B**, which consists of completing the work more commonly known as Project Hopewell: Jackson Street Design & Construction on the real property described on **Exhibit H**, which is attached hereto and made part hereof, at the price described on **Exhibit C**, which is attached hereto and made a part hereof (“**Work**”), and ROI wishes to provide Funds to Contractor to perform the Work.

WHEREAS, Contractor often supplies goods or performs services of a similar nature to the Work as part of its normal business operations.

WHEREAS, pursuant to the Grant Agreement, ROI has requested and received approval of Funds for the Work from the IEDC, in accordance with the Claim Form (as hereinafter defined) in the amount of One Million Eight Hundred Thousand Dollars (\$1,800,000.00) (“**Work Funds**”).

WHEREAS, Contractor requests that Work Funds be obtained and disbursed to Contractor for Contractor’s performance of the Work pursuant to the terms and conditions of this Agreement.

WHEREAS, ROI agrees to disburse Work Funds in accordance with this Agreement.

NOW THEREFORE, in consideration of the mutual promises herein contained and other good and valuable consideration, the receipt and adequacy of which is hereby acknowledged, the parties hereto agree as follows:

1. **TERM OF AGREEMENT**. This agreement shall be effective upon the Effective Date and shall remain in full force and effect, unless sooner terminated in accordance with the terms herein or otherwise extended by the terms hereof, until the later of December 31, 2026, or Contractor’s completion of the Work (the “**Expiration Date**”).

2. **CONTRACTOR INFORMATION.**

- a. Contractor's unique entity identifiers are: NYDCLK4KJDG
- b. If applicable, Contractor represents and warrants that its indirect cost rate, as defined in 2 CFR § 200.414, as amended, for sub-grants is \$0.00. Such information may be transmitted to the IEDC by ROI and the IEDC may post such information to the Grant Management Tool. Indirect costs will not be paid unless expressly and separately consented to by ROI and the IEDC.
- c. Contractor represents and warrants that it is eligible to receive the Work Funds and that the information set forth in the Claim Form is complete and accurate.
- d. Contractor represents, as applicable, that it is currently in compliance with and shall remain in compliance with 2 CFR Part 25, requiring registration in the federal System for Award Management (SAM.gov), as amended from time to time, and 2 CFR Part 170, requiring reporting of subaward and executive compensation information, as amended from time to time.

3. **WORK CLAIM FORM.**

- a. Prior to the execution of this Agreement, the application submitted by Contractor was used by ROI to create the Claim Form ("**Claim Form**") for submittal to the IEDC. The Claim Form was approved by ROI, submitted to the IEDC, and approved by the IEDC for the Work. The IEDC approval letter to the Contractor is attached hereto as **Exhibit D** and made a part hereof. This Agreement shall only be entered into after approval of the Claim Form by the IEDC. All elements required by 2 CFR § 200.332(a) shall be expressly or implicitly included herein.
- b. Contractor shall immediately repay all Work Funds upon notice from the IEDC or ROI that Contractor (i) was ineligible to receive Funds; (ii) made any misrepresentation in this Agreement, the Claim Form, or any other documentation presented to the IEDC or ROI; or (iii) if Contractor performs the Work in any manner contrary to or inconsistent with the Grant Agreement, this Agreement, or the Claim Form.

4. **DISBURSEMENT OF WORK FUNDS.** To receive payment, Contractor shall submit a Grant Payment Request Form ("**Payment Request**"), attached hereto as **Exhibit E** and made a part hereof, and ROI will review and approve the Payment Request submitted by Contractor for Work Funds. Following ROI's review, such Payment Request shall be reviewed and approved by the IEDC.

- a. Payment Requests must be submitted to ROI within twenty-five (25) calendar days following the end of the month in which Work was performed. The IEDC and ROI have the discretion and reserve the right to

not pay any claims submitted later than sixty (60) days following the end of the month in which the services were provided. All final payment requests and reports must be submitted to the IEDC within sixty (60) calendar days after termination or the Expiration Date. Payment for claims submitted after that time may, at the discretion of ROI and the IEDC, be denied. Payment Requests should be submitted on a monthly basis unless otherwise instructed by ROI or the IEDC. Work Funds that have been advanced and are unexpended at the time that the final claim is submitted shall be returned to the State (as defined herein).

- b. Payment Requests must be submitted with accompanying supportive documentation, as designated by the IEDC and/or ROI. Payment Requests submitted without required documentation will be returned to Contractor and not processed for payment. Failure to correct any such issues may result in the denial of a claim for payment.
- c. Each Payment Request shall be deemed a certification by Contractor that, as of the date of such Payment Requests, all representations and warranties contained in this Agreement are true and correct and Contractor is in compliance with all the provisions of this Agreement.
- d. Prior to submitting the Payment Request, Contractor shall deliver to ROI, as applicable, including, but not limited to:
 - i. fully executed copies of any requested, applicable contracts; and
 - ii. corporate documentation reasonably satisfactory to ROI establishing Contractor's organizational existence and authority, as well as establishing the authority of the signatory below to execute this Agreement.
- e. ROI's obligation to approve payment and consent to disbursement of the Work Funds under this Agreement shall be subject to:
 - i. satisfaction of all requirements of Section 4(d);
 - ii. the Work being materially compliant with the timeline provided in the Claim Form, evidence of which Contractor may be required to furnish to the IEDC and/or ROI;
 - iii. the IEDC and/or ROI's determination that Contractor's performance to date conforms with the Work, such determination being made through inspection of the site, Work records, and/or other review, as deemed necessary by the IEDC and/or ROI; and
 - iv. if applicable, certification by an engineer, architect, or other qualified inspector acceptable to ROI that the Work has complied

with all applicable plans, specifications, statute, ordinances, codes, regulations, and other similar requirements as set forth in the construction documents, Claim Form, Payment Request, and this Agreement.

- f. Disbursement of Work Funds for the Work shall be made within forty (40) days of the IEDC's approval of the Payment Request. Unless required by IC § 4-13-2-14.8, as amended from time to time, all payments may be by direct deposit by electronic funds transfer to the financial institution designated by Contractor in writing or by check.
- g. Contractor shall provide notice to ROI when the Work is completed. ROI will subsequently notify the IEDC. ROI and/or the IEDC shall review the Work and shall issue a letter of completion to Contractor to acknowledge the Work completion.

5. **DUTIES AND RESPONSIBILITIES OF CONTRACTOR.** Contractor shall complete the Work in compliance with the provisions of this Agreement, the approved Claim Form, the Grant Agreement, and the federal and State laws. In exchange for receipt of the Work Funds for the Work, Contractor also agrees to comply with the following:

- a. **Compliance with Grant Agreement.** Contractor shall comply with any and all applicable terms, provisions, conditions, and restrictions contained in the Grant Agreement.
- b. **Documentation.** Contractor shall provide ROI with any information or documentation regarding any contracts, accountings, agreements, or similar documents with other parties relating to this Agreement, including any subcontract agreements, interlocal memorandums of understanding, agreements with other state agencies, and developer specifications. Contractor shall provide notice to ROI of any material changes to these contracts, agreements, or similar documents. Contractor shall submit the materially changed contracts, agreements, or similar documents to ROI.
- c. **Contractor's Contractors.** Contractor understands and agrees that Contractor and any of its contractors and/or subcontractors are solely responsible for the selection of vendors, contractors, subcontractors, other Contractors, and similar parties for the performance of the Work. ROI has no responsibility for selecting a vendor, contractor, subcontractor, other Contractor, or similar party for the performance of the Work, regardless of whether ROI has listed the vendor, contractor, subcontractor, or similar party on the Claim Form. ROI shall not be bound by any contracts or agreements of Contractor unless otherwise agreed to by ROI in writing.
- d. **Further Assurances.** Contractor shall, from time to time, execute and deliver all other documents and instruments and do all things and acts as ROI

reasonably deems necessary to comply with the Grant Agreement or carry out, better evidence, or perfect the full meaning of this Agreement.

- e. Compliance with Audit and Reporting Requirements; Maintenance of Records.
 - A. If requested, Contractor shall submit to an audit by the State, or its authorized designee, of funds paid through the Grant Agreement and/or this Agreement and shall make all books, accounting records, and other documents available at all reasonable times during the later of the Grant Agreement or this Agreement and for a period of five (5) years after the final payment for inspection by the IEDC or its authorized designee. Contractor shall furnish one (1) copy to ROI at no cost.
 - B. If Contractor is a non-governmental unit, Contractor shall file the Form E-1 annual financial report if required by IC § 5-11-1-4. The E-1 entity annual financial report will be used to determine audit requirements applicable to non-governmental units under IC § 5-11-1-9. Audits required under this Section must comply with the State Board of Accounts (“SBA”) Uniform Compliance Guidelines for Examination of Entities Receiving Financial Assistance from Governmental Sources, found at: <https://www.in.gov/sboa/files/guidelines-examination-entities-receiving-financial-assistance-government-sources.pdf>, as amended from time to time.
 - f. Closeout of Grant. Contractor shall comply with all applicable administrative actions and work required by 2 CFR § 200.344, as amended from time to time.
 - g. Compliance with Federal Law. Contractor shall remain in compliance with, as applicable, the federal statutes and regulations at 2 CFR § 200 *et seq.*, the Uniform Administrative Requirement, Cost Principles, including but not limited to Subparts A-E. By submitting a claim, Contractor certifies to the IEDC and ROI that all payment claims are allowable, allocable, and reasonable in accordance with 2 CFR § 200.403 and the other cost principles in Subpart E of Part 200, all as amended from time to time.
6. **WORK COMPLETION ACCORDING TO CLAIM FORM.** Contractor has furnished to ROI all agreements, plans, drawings, and specifications, if not provided as part of the Claim Form, in connection with the Work and in accordance with which Contractor is to perform the Work. Additional documents that were not a part of the Claim Form are attached as **Exhibit F** to this Agreement and made a part hereof. Contractor shall provide ROI with any additional agreements, plans, drawings, and specifications entered into after the Effective Date and all amendments to any originally supplied or later provided agreements, plans,

drawings, and specifications. Contractor shall provide all such agreements, plans, drawings, and specifications and amendments thereto to ROI within five (5) days of entering into such agreements, plans, drawings, specifications, or amendment. It is intended that the Claim Form includes everything required and necessary to complete the Work properly, even though certain minor items are not mentioned. All work, when finished, shall be in a complete and undamaged state. Unless otherwise set forth in this Agreement, Contractor shall not undertake any Work that is not a part of the approved Claim Form. The Work is to be made complete in accordance with the Claim Form and to the reasonable satisfaction of ROI, notwithstanding any minor omissions in the plans, drawings, or specifications.

7. **MATERIAL CHANGE.** Contractor shall provide notice to ROI of any material changes to the Work. A material change occurs when there is any of the following: (i) an increase in the total cost of the Work of five percent (5%) or more and which, as a result of that increase, would require additional Work Funds for the Work, (ii) any change that impacts ten percent (10%) or more of the total Cost of the Work, or (iii) change in the nature of the Work from Contractor's submission on the approved Payment Request ("**Material Change**"). ROI shall not be obligated to provide any additional Work Funds, regardless of the increase in the total cost of the Work. After receipt of notice of a Material Change, ROI will notify the IEDC to determine if an amended Payment Request is required to proceed with the Work. Notwithstanding any other remedy herein, in the event that Work Funds have been disbursed to Contractor and the IEDC and/or ROI reasonably determines the Work is becoming unviable for some reason, including due to a Material Change, or either party reasonably determines Work Funds have or will be used in a manner not permitted by this Agreement or the Grant Agreement, Contractor shall cease any further expenditure of Work Funds for the Work until such time as the parties reach an agreement in writing on how to proceed.
8. **RESTRICTIONS OF WORK FUNDS.** Contractor represents and warrants that any Work Funds it receives are for its completion of the Work permitted by this Agreement. Contractor shall promptly notify ROI of any suspected failure to use the Work Funds in accordance with this Agreement. Upon such notification, ROI and Contractor shall work together to resolve the concerns. In the event that ROI determines that there has been a failure to use Work Funds in accordance with this Agreement and said concerns cannot be immediately resolved, ROI will act in accordance with Sections 13 and 14 of this Agreement, unless other remedies are required under the Grant Agreement.
9. **WORK.** Contractor shall furnish all labor, supervision, materials, temporary structures, scaffolding, equipment, tools, and appliances of any sort which are necessary to complete the Work. All construction equipment shall be of adequate size and capacity to safely and efficiently handle the work for which it is used. Contractor shall also satisfy all materials, labor, and standards programs.
10. **COMPLIANCE WITH LAWS.**

- a. Contractor agrees to comply with, and to and work together with ROI to comply with, all applicable federal, state, and local laws, rules, regulations, and ordinances, and all provisions, including but not limited to federal laws and guidance of the ARPA Act, U.S. Treasury guidance and policies, OMB and SBA policies and procedures for reporting, SBA guidance on administration and tracking of federal COVID funds, and any policies or procedures implemented by the IEDC for administration of the program. All such materials required thereby to be included herein are hereby incorporated by reference. Contractor shall be solely responsible and agrees to obtain all necessary permits and licenses required for the Work and shall be responsible for the payment of any required fees. The enactment or modification of any applicable State or federal statute or the promulgation of rules or regulations thereunder after execution of this Agreement shall be reviewed by the IEDC, ROI, and Contractor to determine whether the provisions of this Agreement require formal modification.

- b. Contractor and its agents shall abide by all ethical requirements that apply to persons who have a business relationship with the IEDC, as set forth in IC § 4-2-6, *et seq.*, IC § 4-2-7, *et seq.*, and the regulations promulgated thereunder. **If Contractor has knowledge, or would have acquired knowledge with reasonable inquiry that a State officer, employee, or special State appointee, as those terms are defined in IC § 4-2-6-1, has a financial interest in the Grant, Contractor shall ensure compliance with the disclosure requirements in IC § 4-2-6-10.5 prior to execution of this Agreement.** If Contractor is not familiar with these ethical requirements, Contractor should refer any questions to the Indiana State Ethics Commission, or visit Inspector General's website at <http://www.in.gov/ig>. If Contractor or its agents violate any applicable ethical standards, the IEDC and/or ROI may, in its sole discretion, terminate this Agreement immediately upon notice to Contractor. In addition, Contractor may be subject to penalties under IC § 4-2-6, IC § 4-2-7, IC § 35-44.1-1-4, and under any other applicable laws.

- c. The undersigned attests, subject to the penalties for perjury, that the undersigned is the Contractor or the properly authorized representative, agent, member, or officer of the Contractor. Further, to the undersigned's knowledge, neither the undersigned nor any other member, employee, representative, agent, or officer of Contractor, directly or indirectly, has entered into or been offered any sum of money or other consideration for the execution of this Agreement other than that which appears on the face hereof. **Furthermore, if the undersigned has knowledge that a State officer, employee, or special State appointee, as those terms are defined in IC § 4-2-6-1, has a financial interest in the Work, Funds, or Work Funds, the Contractor attests to compliance with the disclosure requirements in IC § 4-2-6-10.5, all as amended from time to time.**

- d. Contractor represents and warrants that it and any contractors performing the Work will obtain and maintain all required permits, licenses, registrations, and approvals, as well as comply with all health, safety, and environmental statutes, rules, and regulations in performance of work activities related to the Work. In the event that Contractor breaches this covenant, ROI may immediately suspend or terminate the Agreement.
- e. Contractor affirms that, if it is an entity described in IC Title 23, it is properly registered and owes no outstanding reports to the Indiana Secretary of State.
- f. If the IEDC or ROI is asked by the SBA or any agency or instrumentality of the federal government to repay any Work Funds that the IEDC or ROI have disbursed to Contractor, Contractor shall, within thirty (30) days, reimburse those funds to the IEDC or ROI.
- g. As required by IC § 5-22-3-7, as amended from time to time:
 - i. Contractor certifies that:
 - A. Contractor, except for de minimis and nonsystematic violations, has not violated the terms of:
 - 1. IC § 24-4.7 [Telephone Solicitation Of Consumers];
 - 2. IC § 24-5-12 [Telephone Solicitations]; or
 - 3. IC § 24-5-14 [Regulation of Automatic Dialing Machines];in the previous three hundred sixty-five (365) days, even if IC 24-4.7 is preempted by federal law, all as amended from time to time; and
 - B. Contractor will not violate the terms of IC § 24-4.7 for the duration of this Agreement, even if IC § 24-4.7 is preempted by federal law, as amended from time to time.
 - ii. Contractor certifies that an affiliate of Contractor and any agent acting on behalf of Contractor or on behalf of an affiliate of Contractor, except for de minimis and nonsystematic violations,
 - A. has not violated the terms of IC § 24-4.7 in the previous three hundred sixty five (365) days, even if IC § 24-4.7 is preempted by federal law, as amended from time to time; and

- B. will not violate the terms of IC § 24-4.7 for the duration of this Agreement, even if IC § 24-4.7 is preempted by federal law, all as amended from time to time.
 - h. Contractor shall complete and return the Information and Questionnaire, attached as **Exhibit G** and incorporated fully herein, prior to receiving any Work Funds.
 - i. Notwithstanding anything herein to the contrary, any obligation, duties, or compliance responsibility attributed to Contractor in this Agreement shall rest fully and solely with Contractor and not be an obligation, duty, or compliance responsibility of ROI or any agent of ROI.
11. **RISK OF LOSS AND INSURANCE.** The Work shall be under the charge and control of Contractor and all risks of loss or damage in connection therewith and the materials, supplies, and equipment to be used therein shall be borne exclusively by Contractor. Contractor shall maintain, at Contractor's own expense, insurance coverages insuring Contractor, Contractor's employees, agents, and designees, and the indemnitees, as required herein in commercially reasonable amounts, which insurance shall name ROI as an additional named insured and shall incorporate a provision requiring the giving of written notice to ROI at least thirty (30) days prior to the cancellation, non-renewal or material modification of any such policies as evidenced by return receipt of United States Certified Mail. If Work funds will be used for building or construction related costs, Contractor shall also maintain Builder's Risk Insurance in an amount at least equal to the projected completion value of the project for which the Work is being performed. All deductibles of any policy of insurance to be purchased by Contractor hereunder shall be borne by Contractor. Contractor shall submit valid certificates in form and substance satisfactory to ROI evidencing the effectiveness of the foregoing insurance policies along with copies of the amendatory riders to any such policies.
12. **INDEMNITY.** Contractor shall INDEMNIFY, DEFEND, AND HOLD HARMLESS ROI and its officers, employees, and agents from any and all damages, losses, claims, demands, suits, liabilities, penalties, or forfeitures of every kind and nature (collectively "**Claims**"), including but not limited to reasonable attorneys' and experts' fees and expenses and other costs and expenses of defending against the same and payment of any settlement or judgment therefore, by reason of bodily and other personal injuries to or deaths of persons; damages to tools or equipment owned or leased by Contractor; damages to other property; the release or threatened release of a hazardous substance or any pollution or contamination of or other adverse effects on the environment; violations of any applicable laws; or infringement of patent, copyright, trademark, trade secret, or other property right to the extent resulting or alleged to have resulted from acts or omissions of Contractor, its employees, agents, contractors, subcontractors, or other representatives or otherwise arising out of, directly or indirectly relating to, or in connection with the performance of this Agreement, the Work or otherwise, whether suffered directly by ROI or indirectly by reason of third party claims, demands, or suits. This

obligation to indemnify, defend, and hold harmless shall survive termination or expiration of this Agreement and shall apply whether or not it is alleged that ROI or IEDC in any way contributed to the Claims or is liable due to a nondelegable duty, however Contractor shall not be responsible for any Claims which are caused by the sole negligence or sole willful misconduct of ROI where such is contrary to law. The indemnification obligation under the Agreement may not be limited in any way by any limitation on the amount or type of damages, compensation, or benefits payable by or for Contractor or any contractors, subcontractors, or materialmen under worker's or workmen's compensation acts, disability benefit acts, or other employee benefits acts. Without limiting the generality of the foregoing, the indemnity herein shall include all Claims arising out of personal injury, death, or damage to personal property of Contractor or its contractors or subcontractor's employees, agents, licensees, or invitees or to any other persons, whether based upon or claimed to be based upon, statutory, contractual, common law, tort (including but not limited to negligence, fraud, conversion, intentional tort or other common law tort), or other liability of Contractor, Contractor's representatives, employees, contractors, subcontractors, material men or suppliers or any other persons.

13. **LIENS**. Contractor shall make prompt payments to all persons who have done work or furnished materials for Contractor's performance of the Work and shall, from time to time upon demand, furnish satisfactory evidence to ROI that such persons are entitled to no further compensation. In the event a lien shall be filed against the Work by any person who has done work or furnished materials for or in the performance of Contractor or its representatives work, Contractor shall, at its expense, upon demand of ROI, take all necessary action, by bond or otherwise, to cause any such lien to be release or discharged therefrom, and Contractor shall fully indemnify ROI against any loss or expense in connection therewith, including reasonable expert and attorneys' fees incurred by ROI.
14. **SUSPENSION**. Contractor certifies that it has verified the suspension and debarment status for all subcontractors, vendors, and other lower tier subrecipients receiving funds under this Agreement and shall be solely responsible for any recoupments or penalties that might arise from non-compliance. Contractor shall immediately notify ROI if it or any subcontractor becomes debarred or suspended and shall, at the State's request, take all steps required by the IEDC and/or ROI to terminate its contractual relationship with the subcontractor for work to be performed on the Work. ROI reserves the right to immediately suspend, in whole or in part, this Agreement for the appearance of an actual or potential violation of this Agreement or any relevant provision of federal or state laws, rules, or regulations.
15. **TERMINATION**.
 - a. **Termination for Breach**.
 - i. Failure of Contractor to complete the Work in accordance with this Agreement may be considered a material breach and shall entitle

ROI to suspend disbursements associated with the Work and suspend Contractor's participation in ROI's programs, if applicable, until such time as all material breaches are cured to ROI's satisfaction.

- ii. Contractor warrants it will complete the Work in accordance with the Grant Agreement and this Agreement. Breach of this warranty shall entitle the IEDC to suspend payment of the Work Funds and Contractor's receipt of any Funds.
- iii. If the IEDC and/or ROI are subject to any fine, penalty, or fee as a result of Contractor's improper receipt of the Work Funds or performance of the Work, Contractor shall fully reimburse the IEDC and ROI for any incurred expense.

b. Termination for Convenience. In the event the Grant Agreement shall be terminated by the IEDC or ROI, for any reason, this Agreement shall also terminate. Contractor shall be compensated for completion of the Work properly performed prior to the effective date of the termination. ROI shall not be liable for Work performed after the effective date of the termination.

c. Opportunity for Hearing. In all instances of termination for breach or for convenience, Contractor will be provided notice and an opportunity for a hearing according to 2 CFR §§ 200.340 through 200.343, as amended from time to time.

16. **FUNDING CANCELLATION**. As required by Fiscal Management Circular 2007-1 and IC § 5-22-17-5, as amended from time to time, when the Director of the State Budget Agency makes a written determination that Funds and/or Work Funds are not appropriated or otherwise available to support the continuation or performance of this Agreement or the Grant Agreement, this Agreement shall be canceled. A determination by the Director of the State Budget Agency that Funds and/or Work Funds are not appropriated or otherwise available to support the continuation of performance of the Work or Grant Agreement shall be final and conclusive and this Agreement shall immediately terminate.

17. **DRUG-FREE WORKPLACE CERTIFICATION**. As required by Executive Order No. 90-5 dated April 12, 1990, issued by the Governor of Indiana, as amended from time to time, Contractor, if it has employees, hereby covenants and agrees to make a good faith effort to provide and maintain a drug-free workplace. Contractor will give written notice to ROI and the IEDC within ten (10) days after receiving actual notice that Contractor, or an employee of Contractor in the State of Indiana (the "State"), has been convicted of a criminal drug violation occurring in the workplace. False certification or violation of this certification may result in sanctions including, but not limited to, suspension of disbursements under this Agreement, termination of this Agreement, and/or debarment of grant opportunities with the IEDC, ROI, and/or the State for up to three (3) years. In addition to the

provisions of this Section, if the total amount set forth in this Agreement is in excess of \$25,000.00, Contractor certifies and agrees that it will provide a drug-free workplace by:

- a. Publishing and providing to all of its employees a statement notifying them that the unlawful manufacture, distribution, dispensing, possession, or use of a controlled substance is prohibited in Contractor's workplace and specifying the actions that will be taken against employees for violations of such prohibition;
- b. Establishing a drug-free awareness program to inform its employees of (i) the dangers of drug abuse in the workplace; (ii) Contractor's policy of maintaining a drug-free workplace; (iii) any available drug counseling, rehabilitation, and employee assistance programs; and (iv) the penalties that may be imposed upon an employee for drug abuse violations occurring in the workplace;
- c. Notifying all employees in the statement required by subsection (a) above that, as a condition of continued employment, the employee will: (i) abide by the terms of the statement; and (ii) notify Contractor of any criminal drug statute conviction for a violation occurring in the workplace no later than five (5) days after such conviction;
- d. Notifying ROI in writing within ten (10) days after receiving notice from an employee under subdivision (c)(ii) above, or otherwise receiving actual notice of such conviction;
- e. Within thirty (30) days after receiving notice under subsection (c)(ii) above of a conviction, imposing the following sanctions or remedial measures on any employee who is convicted of drug abuse violations occurring in the workplace: (i) take appropriate personnel action against the employee, up to and including termination; or (ii) require such employee to satisfactorily participate in a drug abuse assistance or rehabilitation program approved for such purposes by a federal, State, or local health, law enforcement, or other appropriate agency; and
- f. Making a good faith effort to maintain a drug-free workplace through the implementation of subparagraphs (a) through (e) above.

18. **EMPLOYMENT ELIGIBILITY VERIFICATION**. If required by IC § 22-5-1.7, as amended from time to time, if Contractor has employees, Contractor swears or affirms under the penalties of perjury that:

- a. Contractor has enrolled and is participating in the E-Verify program;
- b. Contractor has provided documentation to ROI and/or the IEDC that it has enrolled and is participating in the E-Verify program;

- c. Contractor does not knowingly employ any unauthorized aliens; and
- d. Contractor shall require its subcontractors who perform work related to the Work to certify to Contractor that the contractor does not knowingly employ or contract with an unauthorized alien and that the contractor has enrolled and is participating in the E-Verify program. Contractor shall maintain this certification throughout the duration of the term of any contract with a contractor.

ROI may terminate this Agreement for default if Contractor fails to cure a breach of this Section no later than thirty (30) days after being notified by the State.

19. **NONDISCRIMINATION.**

- a. Pursuant to IC § 22-9-1-10, the Civil Rights Act of 1964, the Age Discrimination in Employment Act, and the Americans with Disabilities Act, Contractor covenants that it shall not discriminate against any employee or applicant for employment related to this Agreement with respect to the hire, tenure, terms, conditions, or privileges of employment, or any matter directly or indirectly related to employment because of the employee or applicant's race, color, religion, sex, age, disability, national origin, ancestry, status as a veteran, or any other characteristic protected by federal, State, or local law.
- b. Contractor understands that the IEDC and ROI are recipients of federal funds and, therefore, where applicable, Contractor and its subcontractors shall comply with requisite affirmative action requirements, including reporting, pursuant to 41 CFR Chapter 60, as amended, and Section 202 of Executive Order 11246, as amended by Executive Order 13672, all as amended from time to time.
- c. Breach of this covenant may be regarded as a material breach of this Agreement. Acceptance of this Agreement also signifies compliance with applicable federal and state laws and regulations prohibiting the aforementioned discrimination in the provision of services.

20. **DEBARMENT.** Contractor represents, warrants, and certifies that it and its principals are not presently debarred, suspended, proposed for debarment, declared ineligible, or voluntarily excluded from entering into this Agreement by any federal agency or any department, agency, or political subdivision of the State. The term "principal" for the purposes of this Agreement shall mean any officer, director or member.

21. **NOTICES.** All notices to be given under this Agreement shall be in writing, and shall be deemed to have been given and served when delivered in person, by Federal

Express, UPS, or similar overnight carrier, or by United States mail, postage pre-paid to the addressee at the following addresses:

ROI: Regional Opportunity Initiatives, Inc.
Attn: Tina Peterson
100 S. College Avenue, Suite 240
Bloomington, IN 47404
email: readi@regionalopportunityinc.org

Contractor: City of Bloomington – HAND
Attn: John Zody, Director
401 N Morton Street, Suite 130
Bloomington, IN 47404
email: john.zody@bloomington.in.gov

Any party may change its mailing address by serving written notice of such change and of such new address upon the other party.

22. **WORK MONITORING.** The IEDC and/or ROI may conduct on-site or off-site monitoring reviews of the Work during the term of the Grant Agreement and for up to ninety (90) days after the later of the expiration of the Grant Agreement or the Expiration Date. The IEDC and ROI shall not be required to provide Contractor advance notice of such monitoring reviews. Failure to comply with this Section may allow ROI to suspend or terminate this Agreement. Contractor shall extend to the IEDC and ROI and their authorized designees Contractor's full cooperation and give full access to the Work sites and relevant documentation for the purposes of determining, among other things:
- a. Whether Work activities are consistent with those set forth in the Claim Form, including any modification agreed to by the IEDC and ROI, and the terms of the Grant Agreement and this Agreement; and
 - b. That Contractor is making timely progress with the Work and that its management, methods, and overall performance are in conformance with the requirements set forth in the Grant Agreement and this Agreement and are fully and accurately reflected in Work reports submitted to the IEDC and/or ROI.
23. **DISCLOSURE OF PUBLIC RECORDS.** Contractor acknowledges that the IEDC and ROI will not treat this Agreement as containing confidential information. Use by the public of the information contained in this Agreement shall not be considered an act by the State. Confidential financial information and other information that Contractor desires to be withheld from disclosure in accordance with the Indiana Access to Public Records Act should be submitted in a separate addendum clearly designated by Contractor as confidential. Contractor shall also allow ROI to distribute public information, data, or statistics that ROI collects on the Work to third parties.

24. **PUBLIC RELATIONS AND MARKETING.** All external facing communications related to the Grant Agreement and this Agreement, including marketing, public relations, and social media materials and content, shall be developed in consultation with the IEDC and ROI and shall receive written approval from the IEDC and ROI prior to publication. Communications should include appropriate reference to the IEDC and ROI as an investor, partner, and/or sponsor, as applicable, of the program or initiative, including the use of the IEDC and ROI logos and the IEDC and ROI social media tags and reference to the IEDC and ROI social media accounts. All communications required under this paragraph shall be sent to ROI at betsytrozke@regionalopportunityinc.org. Upon approval by ROI, the communications will be forwarded to the IEDC for the IEDC's approval.

25. **USE OF THE IEDC AND ROI NAME.** ROI and IEDC have not granted any rights to use their name, trademark, intellectual property, or logos. Contractor shall not use the IEDC's or ROI's name or intellectual property, including IEDC or ROI trademarks or logos, in any manner, including commercial advertising or as a business reference, without the prior written consent of the IEDC or ROI. For any purposes outside those contemplated by this Agreement, and for which the IEDC's participation will be referenced, the IEDC or ROI shall have the right of review and approval of the use, disclosure, and the finished product prior to publication. All such requests from Contractor must be made in writing and delivered to ROI for approval at its sole discretion. Any requests by Contractor for the use of the IEDC name or intellectual property shall be first submitted to ROI who shall work with the IEDC regarding review and approval.

26. **ASSIGNMENT.** ROI shall have the right to unilaterally assign its rights to recover Funds and/or Work Funds and delegate its rights under this Agreement to the IEDC. In such event, ROI shall provide advance notice to Contractor of such unilateral assignment and delegation. THE PARTIES AGREE THAT IN NO EVENT SHALL THIS PROVISION BE VOIDED OR CONSTITUTE A MATERIAL BREACH AS SIGNATURE TO THIS AGREEMENT SHALL CONSTITUTE THE PARTIES' CONSENT TO ROI'S UNILATERAL ASSIGNMENT AND DELEGATION TO THE IEDC. Contractor shall not assign, transfer, convey, or otherwise dispose of this Agreement or any part hereof, to any person, company, or corporation, without the prior written consent of ROI.

27. **GOOD FAITH ASSURANCES.** The parties to this Agreement shall in good faith undertake to perform their obligations under this Agreement, to satisfy all conditions, and to cause the transactions contemplated by this Agreement to be carried out promptly in accordance with the terms of this Agreement. Upon the execution of this Agreement and thereafter, each party shall do such things as may be reasonably requested by the other party hereto in order more effectively to consummate or document the transactions contemplated by this Agreement.

28. **MISCELLANEOUS.**

- a. The headings in this Agreement are intended solely for reference and will be given no effect in the construction or interpretation of this Agreement.
- b. The parties agree that this Agreement, including any attached exhibits and/or attachments, supersedes all prior oral and written proposals and communications, if any, and sets forth the entire agreement of the parties with respect to the subject matter hereof.
- c. This Agreement may not be altered or amended except in writing, signed by authorized representatives of ROI and Contractor.
- d. No waiver of any default, failure to perform, condition, provision, or breach of this Agreement will be deemed to imply or constitute a waiver of any other like default, failure to perform, condition, provision, or breach of this Agreement.
- e. If any paragraph, term, condition, or provision of this Agreement is found by a court of competent jurisdiction to be invalid or unenforceable, or if any paragraph, term, condition, or provision is found to violate or contravene the laws of the State of Indiana, then the paragraph, term, condition, or provision so found will be deemed severed from this Agreement, but all other paragraphs, terms, conditions, and provisions will remain in full force and effect.
- f. This Agreement shall be governed in accordance with the laws of the State of Indiana without regard to its conflicts of laws rules. The venue for disputes hereunder shall be exclusive to state courts of Dubois County, Indiana and federal courts located in the Southern District of Indiana.
- g. Contractor shall be responsible for providing all legally required unemployment and workers' compensation insurance for its employees, if any.
- h. Unless otherwise terminated or modified as expressly permitted hereunder, this Agreement shall remain in force during the term of this Agreement. Notwithstanding anything contained herein to the contrary, provisions of this Agreement which by their nature contemplate rights and obligations of the parties to be enjoyed or performed after the Expiration Date shall survive until their purposes are fulfilled.
- i. This Agreement may be executed through an original or electronically, and in duplicate or through counterparts, each of which shall be deemed to be an original, and all of which shall constitute but one and the same agreement.

- j. Any information technology related products or services purchased, used, or maintained through this Agreement must be compatible with the principles and goal contained in the Electronic and Information Technology Accessibility Standards adopted by the Architectural and Transportation Barriers Compliance Board under Section 508 of the federal Rehabilitation Act of 1973 (29 USC 794d), as amended from time to time. The federal Electronic and Information Technology Accessibility Standards can be found at: <https://www.access-board.gov/ict.html>.
- k. If “Contractor” refers to more than one entity, each entity shall be jointly and severally responsible to satisfy the obligations under this Agreement. In the event of a default, all Contractor entities are jointly and severally liable for the obligations in this Agreement, irrespective of which entity caused the default.
- l. Nothing in this Agreement shall be construed to confer any rights or remedies on any third party not a signatory to this Agreement, including the employees, or other contractors of Contractor.
- m. This Agreement was reviewed and/or revised by legal counsel for ROI and Contractor, and no presumption or rule that ambiguity shall be construed against the party drafting the document shall apply to the interpretation or enforcement of this Agreement.
- n. Nothing in this Agreement is intended to preclude or limit ROI’s ability to seek remedies available at law or in equity against Contractor in respect to claims of mismanagement, misappropriation, fraud, concealment, or similar claims of disbursed Work Funds.
- o. The parties acknowledge and agree that the recitals contained in the preamble of this Agreement are true and correct and are incorporated into this Agreement by this reference.

[Signatures on Following Page.]

IN WITNESS WHEREOF, the parties hereto have caused this Contractor Agreement to be executed as of the date first written above.

ROI:

**REGIONAL OPPORTUNITY INITIATIVES,
INC.**

By: _____
Tina Peterson, President and CEO

CONTRACTOR:

CITY OF BLOOMINGTON, INDIANA

By: _____
(Signature)

(Printed)

(Title)

Index of Exhibits:

Exhibit A	Grant Agreement
Exhibit B	Consolidated Project Report
Exhibit C	Work Budget
Exhibit D	IEDC Approval Letter
Exhibit E	Grant Payment Request Form
Exhibit F	Additional Plans and Specifications
Exhibit G	Information and Questionnaire
Exhibit H	Legal Description

GRANT AGREEMENT

This Grant Agreement (the “Grant Agreement”), entered into by and between the **INDIANA ECONOMIC DEVELOPMENT CORPORATION** (the “IEDC”) and **REGIONAL OPPORTUNITY INITIATIVES, INC.** (the “Grantee”), is executed pursuant to the terms and conditions set forth herein. In consideration of those mutual undertakings and covenants, the parties agree as follows:

1. Purpose of this Grant Agreement; Funding Source.

IEDC is a pass-through subrecipient of federal monies granted from Coronavirus State Fiscal Recovery Funds to the State of Indiana (the “Federal Program”). The purpose of this Grant Agreement is to enable the IEDC to award a Grant of \$30,000,000.00 (the “Grant”) to the Grantee, a lower tier subrecipient under the Federal Program, for Eligible Costs (as herein defined) to implement programs as outlined in the Grantee’s grant application (the “Plan”) including awards (“Sub-Grants”) to other public and private entities (“Subrecipient(s)”) for the performance of a service or project (individually a “Project” collectively the “Projects”) as described in Exhibit A to this Grant Agreement, which is incorporated fully herein and which may be amended from time to time. The Grant shall be used exclusively in accordance with the provisions contained in this Grant Agreement. The Grant received by the Grantee pursuant to this Grant Agreement shall be used only to implement or fund a Project in conformance with this Grant Agreement and for no other purpose.

A. Grant Information:

- (1) Assistance listing (CFDA) number: 21.027
- (2) Assistance Listing Title: Coronavirus State and Fiscal Recovery Funds
- (3) Federal Award Name: Coronavirus State Fiscal Recovery Funds (SLFRF)
- (4) Federal Award Identification Number: N/A
- (5) Federal Award Date: March 11, 2021
- (6) Name of Federal Agency: U.S. Department of the Treasury
- (7) Subrecipient unique entity identifier(s): 78EN2D47QM49
- (8) If applicable to a Subrecipient, Grantee shall require any such Subrecipient to provide their indirect cost rate, as defined in 2 CFR § 200.414, as amended from

time to time, for Sub-Grants. Such information shall be posted to the Grant Management Tool at the direction of the IEDC.

(9) “**Eligible Costs**” are defined as:

a. **Statutory Uses:**

- i. To respond to the COVID-19 public health emergency or its negative economic impacts.
- ii. To respond to workers performing essential work during the COVID-19 public health emergency by providing grants to eligible employers that have eligible workers who performed essential work;
- iii. For the provision of government services, to the extent of the reduction in revenue of such recipient due to the COVID-19 public health emergency, relative to revenues collected in the most recent full fiscal year of the recipient prior to the emergency; and/or
- iv. To make necessary investments in water, sewer, or broadband infrastructure.

b. “**Administrative Uses**”. Administrative Uses shall include but are not limited to project support costs, Grant management, Grant compliance, office personnel, legal fees subject to the limitations of 2 CFR §§ 200.435 and 200.441, accounting fees, audit fees and all other administrative costs not specifically prohibited by this Grant Agreement.

(10) **Closeout of Grant:** The IEDC and Grantee shall comply with all applicable administrative actions and work required by 2 CFR § 200.344, as amended from time to time.

2. Representations and Warranties of the Grantee.

- A. The Grantee expressly represents and warrants to the IEDC that it is eligible to receive Grant funds and that the information set forth in its Plan is true, complete, and accurate. The Grantee expressly agrees to promptly repay all funds paid to it under this Grant Agreement should it be determined that it was ineligible to receive the funds, made any misrepresentation on its Plan or used funds for any purpose or in any manner contrary to or inconsistent with this Grant Agreement.
- B. If Grant funds are awarded to a Subrecipient, Grantee shall require each Subrecipient to represent and warrant to the Grantee that it is eligible to receive the Grant funds and that the information set forth in its Claim Form (as herein defined) is complete and accurate. The Grantee agrees to diligently pursue the repayment of all funds paid to said Subrecipient should it be determined that it was ineligible to receive the funds,

made any misrepresentation on its Claim Form or used Grant funds for any purpose or in any manner contrary to or inconsistent with this Grant Agreement or the Claim Form.

- C. The Grantee represents, as is applicable, that it is currently in compliance with and shall remain in compliance with 2 C.F.R. Part 25, requiring registration in the federal System for Award Management (SAM.gov) as amended from time to time, and 2 C.F.R. Part 170, requiring reporting of subaward and executive compensation information, as amended from time to time.

3. Grant Funding.

- A. The IEDC shall fund this Grant in the amount of \$30,000,000.00.
- B. The Grantee agrees that local and private dollars will be expended by the Grantee and Subrecipients for projects funded by this Grant at the minimum of a 4:1 ratio to Grant dollars provided under this Grant Agreement by the completion of the Plan. The 4:1 match must be comprised of a minimum of a 1:1 ratio in Grant dollars to local public funding by the completion of the Plan. Public funding may, as appropriate, include private non-profit economic development organizations and foundations. Grantee must provide evidence of compliance with this paragraph 3(B) upon completion of the Plan in a format designated by the IEDC.
- C. The disbursement of Grant funds to the Grantee shall not be made until all documentary materials required by this Grant Agreement have been received and approved by the IEDC and this Grant Agreement has been fully approved by the State of Indiana (the "State").
- D. The Grantee shall remain in compliance with the federal statutes and regulations at 2 C.F.R. 200 *et seq.*, the Uniform Administrative Requirement, Cost Principles and Audit Requirements for Federal Awards, including but not limited to Subparts A-F, as required by the Grant. By submitting a claim under Paragraph 6, the Grantee certifies to the IEDC that all payment claims are allowable, allocable, and reasonable in accordance with 2 C.F.R. 200.403 and the other cost principles in Subpart E of Part 200, as all are amended from time to time.

4. Term.

- A. This Grant Agreement is effective January 1, 2022 and shall remain in effect through December 31, 2026 ("**Expiration Date**"). The term of this Grant Agreement may be extended upon the written agreement of the parties and as permitted by State or federal laws governing this Grant.
- B. Grant funds must be obligated by December 31, 2024 ("**Grant Obligation Date**") and may continue to be liquidated through December 31, 2026. On or before June 1, 2023, a plan must be submitted to the IEDC detailing how all currently unobligated

funds will be obligated by the Grant Obligation Date. If Grantee is not able to obligate funds by the Grant Obligation Date, the IEDC may reallocate Grant funds.

- C. Project Claim Forms, as further defined in Paragraph 5 below, must be submitted to the IEDC for approval by June 30, 2023, unless an extension of time has been granted in writing.
- D. The Grantee shall have sixty (60) days following to the Expiration Date to submit all final claims for disbursement of Grant funds under this Grant Agreement.
- E. Any provisions which, by their nature, are intended to apply after the termination of this Grant Agreement shall survive the termination of the Grant Agreement until their purposes are fulfilled.

5. Implementation of and Reporting on the Plan.

- A. The Grantee shall be solely responsible for carrying out all planning and coordination activities necessary to distribute Grant funds and implement those Projects selected from the Plan in accordance with this Grant. Modification of the Plan shall require prior written approval of the IEDC, which approval shall not be unreasonably withheld or delayed.
- B. For each Project for which the Grantee requests disbursement of funds, the Grantee shall submit to IEDC a Project Claim Form (the “**Claim Form**”).
 - (1) The Claim Form, attached herein by reference, will be made available to the Grantee through an online Grant Management Tool or file sharing platform (the “**Grant Management Tool**”), which is attached herein by reference and subject to reasonable modification over time.
 - (2) A separate Claim Form must be completed for each Project.
 - (3) Each Claim Form shall include:
 - (a) A detailed description of the Project and its alignment with the Plan (if not already a part of the Plan).
 - (b) All required programmatic data and performance indicators, as fully described on the Grant Management Tool.
 - (c) A detailed budget including all sources and uses of funding required to implement the Project (“**Project Budget**”).
 - (i) After the IEDC approves a Claim Form, the Project Budget funded by this Grant Agreement, and those funded by any local and/or private party, shall not experience a Material Change (as herein defined) without the prior

written consent of the IEDC.

- (ii) For any in-kind contribution, the Grantee, or Subrecipient as applicable, shall provide a reasonable value associated with each such contribution. The IEDC may question the value attributed to an in-kind contribution, request supporting documentation, and request an adjustment by the Grantee before a Claim Form is approved.
 - (d) The amount of any administrative fee to be withheld by the Grantee to implement the Project or for other Administrative Uses, shall not exceed the limits established in Paragraph 5.C. of this Grant Agreement, and Grantee shall provide a detailed description of the services that will be rendered by the Grantee with support of the administrative fee.
 - (e) The name and contact information for the Grantee and any Subrecipients, and a certification from the Grantee and Subrecipients that they are in compliance with all applicable State and federal laws.
 - (f) Any other information or documentation required by the IEDC.
- (4) The Grantee may submit Claim Forms for Projects not initially included in the Plan as an additional Project or Projects of the Plan, provided that such Projects may be subject to additional requests for information or documentation from the IEDC. If a Claim Form for a Project not initially included in the Plan is approved by the IEDC, the Project shall automatically become part of the Grantee's Plan.
 - (5) The IEDC shall have thirty (30) days to evaluate a submitted Claim Form and provide notice of its decision to approve or deny the Claim Form. If additional time is needed to evaluate a submitted Claim Form, the IEDC shall notify the Grantee of a date by which its decision can be expected. The IEDC agrees that it will not unreasonably extend any such review.
 - (6) The Grantee understands and agrees that the IEDC retains the right to approve or deny a Claim Form, as solely determined by the IEDC in accordance with this Grant Agreement.
 - (7) The IEDC may condition its approval of a submitted Claim Form as it deems appropriate. The Grantee may then accept, reject, request further revision to the conditional approval, or submit an amended Claim Form. A conditionally approved claim form shall only be considered approved if the Grantee gives written notice of its acceptance of such Claim Form and subsequently provides documentation of its satisfaction of the IEDC's conditions.
 - (8) The IEDC may at any time (before or after the IEDC's approval of a Claim form) request from the Grantee, in writing, any additional information or documentation relating to a Project necessary for the IEDC to perform its obligations under this

Grant Agreement. The Grantee shall use its best efforts to obtain these materials and provide them to the IEDC within a reasonable time period.

- (9) After a Claim Form is approved by the IEDC, the Grantee shall provide notice to the IEDC of any Material Changes to a Project. A "Material Change" occurs when there is any:
 - a. Increase in the total cost of a Project of five percent (5%) or more and which, as a result of that increase, would require additional Grant funds for the Project;
 - b. Change in the nature of a Project from the Grantee's submission on the approved Claim Form, including a change in how the Grant funds will be used for an approved Project, such as to provide funding for administrative services at a daycare facility rather than to construct the daycare facility.
- (10) After no longer than ten (10) business days after receipt of a notice of Material Change, the IEDC will notify the Grantee if an amended Claim Form is required to proceed with the Project.
- (11) In the event there is a Material Change requiring an amended Claim Form, such Claim Form will be subject to the IEDC's further approval or denial.
- (12) It is expressly understood and agreed by the Grantee and the IEDC that the Grantee may distribute the funds granted to the Grantee hereunder to Subrecipients (the "**Subrecipients**") to perform a Project as the Grantee deems acceptable, provided however, the Grantee shall remain obligated to perform all of its obligations under this Grant Agreement and/or to ensure that Subrecipients comply with the same, if applicable.
- (13) The Grantee shall be solely responsible for overseeing and/or completing the proper design and implementation of a Project approved by the IEDC. The Grantee shall make certain that it and any Subrecipient completes an approved Project in accordance with this Grant Agreement, the approved Claim Form, and its Plan.
- (14) The Grantee may enter into any contracts or agreements necessary or incidental to the performance of this Grant Agreement; however, the IEDC shall not be bound by any contracts or agreements of the Grantee's unless otherwise agreed to by the IEDC in writing.
- (15) The Grantee understands and agrees that the Grantee and any of its own selected Subrecipients are solely responsible for selection of vendors, contractors, other sub-Subrecipients or similar parties for the performance of Projects. The IEDC has no role in selecting a vendor, contractor, Subrecipient (except for approval of the Claim Form), or similar party for the performance of Projects, regardless of whether the Grantee has listed the vendor, contractor, Subrecipient, or similar

party on the Claim Form.

(16) After a claim form is submitted, the Grantee shall submit to the IEDC, through the Grant Management Tool, written progress reports until the completion of the Project. These reports shall be submitted on a monthly basis not later than the seventh (7th) day of the month following the month subject to the report and shall contain such detail of progress or performance on the Plan and any Projects funded through this Grant Agreement as is requested by the IEDC.

C. The Grantee and the IEDC agree that a portion of the funds provided under this Grant Agreement may be used for Administrative Uses for the Projects, Federal Program, Grant and to implement the Grantee's Plan in compliance with all applicable State and federal laws. The Grantee shall account for the use of these administrative funds in the monthly report it submits to the IEDC as provided in Paragraph 5(B)(16). The parties agree that:

- (1) The Grantee shall receive one half of one percent (0.50%) of the Grant funds as a reduction of the Grant amount from the IEDC within thirty-five (35) days from the Effective Date, which may be used by the Grantee for Administrative Uses.
- (2) The Grantee may request, in a submitted Claim Form, to retain up to three percent (3%) of the total cost of each Project from the Grant funds requested in the Claim Form, which may be used by the Grantee for Administrative Uses. No more than three percent (3%) of the total Grant funds may be claimed by the Grantee for its Administrative Uses.
- (3) The IEDC will retain three percent (3%) of the total Grant funds, as a reduction to the total Grant amount, for the IEDC's costs associated with overseeing this Grant Agreement, monitoring the Grantee's compliance with applicable State and federal laws in accordance with Paragraph 9, and providing advisory services to facilitate the Grantee's successful implementation of its Plan.

6. Payment of Claims.

A. If advance payment or a working capital advance of all or a portion of the Grant funds for a Project is permitted by statute or regulation, and the IEDC agrees to provide such advance payment or working capital advance, advance payment shall be made only upon submission of a Claim Voucher ("**Claim Voucher**"), attached hereto as **Exhibit B** and made apart hereof, setting out the intended purposes of those funds. After such funds have been expended, Grantee shall provide IEDC with a reconciliation of those expenditures. Otherwise, the Grantee shall review and approve all Claim Vouchers submitted by Subrecipients for Project expenditures eligible for Grant funds, which shall then be reviewed and approved by the IEDC. All requests for Projects performed directly by the Grantee shall be reviewed by the IEDC. Disbursements of Grant funds shall be made by the IEDC within thirty-five (35) days of IEDC approval. As required by IC § 4-13-2-14.8, as amended from time to time, all payments will be

by direct deposit by electronic funds transfer to the financial institution designated by the Grantee in writing unless a specific waiver has been obtained from the Indiana Auditor of State.

- B. Requests for payment will be processed only upon presentation of a Claim Voucher. Such Claim Vouchers must be submitted with an accounting of expenditures organized by Project.
- C. The IEDC may require evidence, furnished by the Grantee, that the Project is materially compliant with the timeline provided in the Claim Form. All payments are subject to the IEDC's determination that the Grantee's, or Subrecipient's, performance to date conforms with the Project as approved, notwithstanding any other provision of this Grant Agreement.
- D. Claim Vouchers shall be submitted to the IEDC within thirty (30) calendar days following the end of the month in which work on or for the Project was performed. The IEDC has the discretion, and reserves the right, to NOT pay any claims submitted later than sixty (60) calendar days following the end of the month in which the services were provided. All final claims and reports must be submitted to the IEDC within sixty (60) calendar days after termination or the Expiration Date. Payment for claims submitted after that time may, at the discretion of the IEDC, be denied. Claims may be submitted on a monthly basis only. Grant funds that have been advanced and are unexpended at the time that the final claim is submitted shall be returned to the State.
- E. Claim Vouchers must be submitted with accompanying supportive documentation, as designated by the IEDC. Claim Vouchers submitted without supportive documentation will be returned to the Grantee and not processed for payment. Failure to correct said issues may result in the denial of a claim for payment.

7. Project Monitoring by the IEDC.

The IEDC may conduct on-site or off-site monitoring reviews of a Project during the term of this Grant Agreement and for up to ninety (90) days after it expires or is otherwise terminated. The Grantee shall extend to the IEDC and its authorized designees its full cooperation and give full access to its Project sites and to relevant documentation; or, if applicable, the Grantee shall require each Subrecipient to provide full cooperation and access to its Project sites and relevant documentation to the IEDC, or its authorized designees, for the purpose of determining, among other things:

- A. Whether Project activities are consistent with those set forth in the Claim Form, including any modification agreed to by the IEDC, and the terms and conditions of the Grant Agreement;
- B. The actual expenditure of State, local and/or private funds expended to date on the Project is in conformity with the amounts for each Project Budget and the Claim Form, and that unpaid costs have been properly accrued;

- C. That Grantee is making timely progress with the Project, and that its project management, financial management, control systems, procurement systems, methods, and overall performance are in conformance with the requirements set forth in this Grant Agreement and are fully and accurately reflected in Project reports submitted to the IEDC.

8. Compliance with Audit and Reporting Requirements; Maintenance of Records.

- A. The Grantee, any fiscal agent of Grantee, and Subrecipients shall submit to an audit by the State, or its authorized designee, of funds paid through this Grant Agreement and shall make all books, accounting records and other documents available at all reasonable times during the term of this Grant Agreement and for a period of five (5) years after final payment for inspection by the IEDC or its authorized designee. One (1) Copy shall be furnished to the IEDC at no cost.
- B. Grantee shall arrange for a financial and compliance audit that complies with 2 C.F.R. 200.500 *et seq.* if required by applicable provisions of 2 C.F.R. 200 (Uniform Administrative Requirements, Cost Principles, and Audit Requirements).
- C. Separate and apart from the Grantee's status in paragraph 8.B, if the Grantee is a non-governmental unit, the Grantee shall file the Form E-1 annual financial report required by IC § 5-11-1-4. The E-1 entity annual financial report will be used to determine audit requirements applicable to non-governmental units under IC § 5-11-1-9. Audits required under this section must comply with the State Board of Accounts ("SBA") Uniform Compliance Guidelines for Examination of Entities Receiving Financial Assistance from Governmental Sources, found at: <https://www.in.gov/sboa/files/guidelines-examination-entities-receiving-financial-assistance-government-sources.pdf>, as amended from time to time.

9. Compliance with Laws.

- A. The Grantee and IEDC shall work together to comply with all applicable federal, state and local laws, rules, regulations and ordinances, and all provisions, including but not limited to federal laws and guidance of the ARPA Act, U.S. Treasury guidance and policies, OMB and SBA policies and procedures for reporting, SBA guidance on administration and tracking of federal COVID funds, and any policies or procedure implemented by IEDC for administration of the program. All such materials required thereby to be included herein are hereby incorporated by reference. The enactment or modification of any applicable State or federal statute or the promulgation of rules or regulations thereunder after execution of this Grant Agreement shall be reviewed by the IEDC and the Grantee to determine whether the provisions of this Grant Agreement require formal modification.
- B. The Grantee and its agents shall abide by all ethical requirements that apply to persons who have a business relationship with the IEDC as set forth in IC § 4-2-6, *et seq.*, IC §

4-2-7, *et seq.* and the regulations promulgated thereunder. **If the Grantee has knowledge, or would have acquired knowledge with reasonable inquiry, that a State officer, employee, or special State appointee, as those terms are defined in IC 4-2-6-1, has a financial interest in the Grant, the Grantee shall ensure compliance with the disclosure requirements in IC § 4-2-6-10.5 prior to the execution of this Grant Agreement.** If the Grantee is not familiar with these ethical requirements, the Grantee should refer any questions to the Indiana State Ethics Commission, or visit the Inspector General's website at <http://www.in.gov/ig/>. If the Grantee or its agents violate any applicable ethical standards, the IEDC may, in its sole discretion, terminate this Grant immediately upon notice to the Grantee. In addition, the Grantee may be subject to penalties under IC §§ 4-2-6, 4-2-7, 35-44.1-1-4, and under any other applicable laws.

- C. The Grantee certifies by entering into this Grant Agreement that, to the best of its knowledge, it is not presently in arrears in payment of taxes, permit fees or other statutory, regulatory, or judicially required payments to the State. The Grantee agrees that any payments currently due to the IEDC may be withheld from payments due to the Grantee. Additionally, payments may be withheld, delayed, or denied and/or this Grant suspended until the Grantee is current in its payments and has submitted proof of such payment to the IEDC.
- D. The Grantee warrants that, to the best of its knowledge, it has no current, pending or outstanding criminal, civil, or enforcement actions initiated by the State, and agrees that it will immediately notify the IEDC of any such actions. During the term of such actions, the Grantee agrees that the IEDC may suspend funding for the Project. If a valid dispute exists as to the Grantee's liability or guilt in any action initiated by the IEDC, and the IEDC decides to suspend funding to the Grantee, the Grantee may submit, in writing, a request for review to the Indiana Department of Administration (IDOA). A determination by IDOA shall be binding on the parties. Any disbursements that the IEDC may delay, withhold, deny, or apply under this section shall not be subject to penalty or interest.
- E. The Grantee warrants that, to the best of its knowledge, the Grantee and any contractors performing work in connection with a Project shall obtain and maintain all required permits, licenses, registrations, and approvals, and shall comply with all health, safety, and environmental statutes, rules, or regulations in the performance of work activities for the State. Failure to do so may be deemed a material breach of this Grant Agreement and grounds for immediate termination and denial of grant opportunities with the State.
- F. The Grantee affirms that, if it is an entity described in Indiana Code Title 23, it is properly registered and owes no outstanding reports to the Indiana Secretary of State.
- G. If the IEDC is asked by the State Budget Agency or any agency or instrumentality of the Federal government to repay any Grant funds that the IEDC has disbursed to Grantee, the Grantee shall, within thirty (30) days, reimburse those funds to the IEDC.

H. As required by IC § 5-22-3-7, as amended from time to time:

(1) The Grantee certifies (and Grantee shall require any Subrecipient to certify) that:

(A) the Grantee (or Subrecipient), except for de minimis and nonsystematic violations, has not violated the terms of:

(i) IC § 24-4.7 [Telephone Solicitation Of Consumers];

(ii) IC § 24-5-12 [Telephone Solicitations]; or

(iii) IC § 24-5-14 [Regulation of Automatic Dialing Machines];

in the previous three hundred sixty-five (365) days, even if IC 24-4.7 is preempted by federal law, all as amended from time to time; and

(B) the Grantee will not violate the terms of IC § 24-4.7 for the duration of this Grant Agreement, even if IC §24-4.7 is preempted by federal law, all as amended from time to time.

(2) The Grantee certifies that an affiliate of the Grantee and any agent acting on behalf of the Grantee or on behalf of an affiliate of the Grantee, except for de minimis and nonsystematic violations,

(A) has not violated the terms of IC § 24-4.7 in the previous three hundred sixty-five (365) days, even if IC § 24-4.7 is preempted by federal law, all as amended from time to time; and

(B) will not violate the terms of IC § 24-4.7 for the duration of this Grant Agreement even if IC § 24-4.7 is preempted by federal law, all as amended from time to time.

I. The Grantee shall complete and return the Information and Questionnaire, attached as **Exhibit C** and incorporated fully herein. In addition, the Grantee shall require all Subrecipients to complete the same prior to any award.

J. Notwithstanding anything herein to the contrary, any obligation, duties or compliance responsibility set forth under this Grant Agreement on Grantee shall rest fully and solely with said Grantee entity and not be an obligation, duty or compliance responsibility of the individual volunteer commissioner, member, officer, agent, or representative serving said Grantee entity, except for any intentional malicious

actions by such individual.

10. Debarment and Suspension.

- A. The Grantee certifies by entering into this Grant Agreement that it is not presently debarred, suspended, proposed for debarment, declared ineligible, or voluntarily excluded from entering into this Grant Agreement by any federal agency or by any department, agency, or political subdivision of the State.
- B. The Grantee certifies that it has verified the suspension and debarment status for all subcontractors, vendors, or other lower tier subrecipients receiving funds under this Grant Agreement and shall be solely responsible for any recoupments or penalties that might arise from non-compliance. The Grantee shall immediately notify the IEDC if any Subrecipient or subcontractor becomes debarred or suspended, and shall, at the State's request, take all steps required by the IEDC to terminate its contractual relationship with the Subrecipient or subcontractor for work to be performed under this Grant Agreement.

11. Drug-Free Workplace Certification.

As required by Executive Order No. 90-5, April 12, 1990, issued by the Governor of Indiana, as amended from time to time the Grantee hereby covenants and agrees to make a good faith effort to provide and maintain a drug-free workplace. Grantee will give written notice to the IEDC within ten (10) days after receiving actual notice that an employee of the Grantee in the State of Indiana, has been convicted of a criminal drug violation occurring in the workplace. False certification or violation of the certification may result in sanctions including, but not limited to, suspension of Grant payments, termination of the Grant and/or debarment of grant opportunities with the IEDC of Indiana for up to three (3) years.

In addition to the provisions of the above paragraphs, if the total amount set forth in this Grant Agreement is in excess of \$25,000.00, the Grantee certifies and agrees that it will provide a drug-free workplace by:

- A. Publishing and providing to all of its employees a statement notifying them that the unlawful manufacture, distribution, dispensing, possession or use of a controlled substance is prohibited in the Grantee's workplace and specifying the actions that will be taken against employees for violations of such prohibition; and
- B. Establishing a drug-free awareness program to inform its employees of: (1) the dangers of drug abuse in the workplace; (2) the Grantee's policy of maintaining a drug-free workplace; (3) any available drug counseling, rehabilitation, and employee assistance programs; and (4) the penalties that may be imposed upon an employee for drug abuse violations occurring in the workplace; and

- C. Notifying all employees in the statement required by subparagraph (A) above that as a condition of continued employment the employee will: (1) abide by the terms of the statement; and (2) notify the Grantee of any criminal drug statute conviction for a violation occurring in the workplace no later than five (5) days after such conviction; and
- D. Notifying in writing the IEDC within ten (10) days after receiving notice from an employee under subdivision (C)(2) above, or otherwise receiving actual notice of such conviction; and
- E. Within thirty (30) days after receiving notice under subdivision (C)(2) above of a conviction, imposing the following sanctions or remedial measures on any employee who is convicted of drug abuse violations occurring in the workplace: (1) take appropriate personnel action against the employee, up to and including termination; or (2) require such employee to satisfactorily participate in a drug abuse assistance or rehabilitation program approved for such purposes by a federal, State or local health, law enforcement, or other appropriate agency; and
- F. Making a good faith effort to maintain a drug-free workplace through the implementation of subparagraphs (A) through (E) above.

12. Employment Eligibility Verification.

As required by IC § 22-5-1.7, as amended from time to time, if the Grantee has employees, the Grantee hereby swears or affirms under the penalties of perjury that:

- A. The Grantee has enrolled and is participating in the E-Verify program;
- B. The Grantee has provided documentation to the IEDC that it has enrolled and is participating in the E-Verify program;
- C. The Grantee does not knowingly employ an unauthorized alien;
- D. The Grantee shall require its contractors who perform work under this Grant Agreement to certify to Grantee that the contractor does not knowingly employ or contract with an unauthorized alien and that the contractor has enrolled and is participating in the E-Verify program. The Grantee shall maintain this certification throughout the duration of the term of a contract with a contractor.

The IEDC may terminate for default if the Grantee fails to cure a breach of this provision no later than thirty (30) days after being notified by the State.

13. Funding Cancellation.

As required by Financial Management Circular 2007-1 and IC § 5-22-17-5, as amended from time to time, when the Director of the State Budget Agency makes a written

determination that funds are not appropriated or otherwise available to support continuation of performance of this Grant Agreement, it shall be canceled. A determination by the State Budget Agency that funds are not appropriated or otherwise available to support continuation of performance shall be final and conclusive.

14. Disputes and Governing Law.

- A. In the event of a dispute between IEDC and the Grantee, other than that addressed by Section 9(D) above, the parties agree to cooperatively negotiate a resolution and escalate to senior management as needed. For any disputes that remain in controversy after thirty (30) days, either party may, at its own expense, initiate legal action. Both parties agree that disputes shall not be arbitrated.
- B. This Grant Agreement shall be governed, construed, and enforced in accordance with the laws of the State of Indiana, without regard to its conflict of laws rules. Suit, if any, must be brought in Marion County, Indiana.

15. Information Technology Accessibility Standards.

Any information technology related products or services purchased, used, or maintained through this Grant must be compatible with the principles and goals contained in the Electronic and Information Technology Accessibility Standards adopted by the Architectural and Transportation Barriers Compliance Board under Section 508 of the federal Rehabilitation Act of 1973 (29 U.S.C. §794d), as amended from time to time. The federal Electronic and Information Technology Accessibility Standards can be found at: <https://www.access-board.gov/ict.html>.

16. Insurance.

The Grantee shall maintain insurance with coverages in such amount as may be required by the IEDC or as provided in its Grant Application.

17. Nondiscrimination.

Pursuant to the Indiana Civil Rights Law, specifically IC § 22-9-1-10, as amended from time to time, and in keeping with the purposes of the federal Civil Rights Act of 1964, the Age Discrimination in Employment Act, and the Americans with Disabilities Act, the Grantee covenants that it shall not discriminate against any employee or applicant for employment relating to this Grant with respect to the hire, tenure, terms, conditions or privileges of employment or any matter directly or indirectly related to employment, because of the employee or applicant's: race, color, national origin, religion, sex, age, disability, ancestry, status as a veteran, or any other characteristic protected by federal, State, or local law ("Protected Characteristics"). Furthermore, Grantee certifies compliance with applicable federal laws, regulations, and executive orders prohibiting discrimination based on the Protected Characteristics in the provision of services.

The Grantee understands that the IEDC is a recipient of federal funds, and therefore, where applicable, Grantee subrecipients, and subcontractors shall comply with requisite affirmative action requirements, including reporting, pursuant to 41 CFR Chapter 60, as amended, and Section 202 of Executive Order 11246 as amended by Executive Order 13672, all as amended from time to time.

18. Notice to Parties.

Whenever any notice, statement or other communication is required under this Grant Agreement, it will be sent by E-mail or first class U.S. mail service to the following addresses, unless otherwise specifically advised.

A. INDIANA ECONOMIC DEVELOPMENT CORPORATION

Attn: General Counsel
One North Capitol Avenue, Suite 700
Indianapolis, IN 46204-2288
reports@iedc.in.gov

B. Notices to the Grantee shall be sent to:

Regional Opportunity Initiatives, Inc.
ATTN: Tonia Peterson, CEO + President
100 S. College Avenue, Suite 240
Bloomington, IN 47403
E-mail: Tonia.peterson@regionalopportunityinc.org

19. Order of Precedence; Incorporation by Reference.

Any inconsistency or ambiguity in this Grant Agreement shall be resolved by giving precedence in the following order: (1) requirements imposed by applicable federal or State law, including those identified in paragraph 9, above; (2) this Grant Agreement; (3) Exhibits prepared by the IEDC; (4) the Grant Management Tool; (5) the Plan; and (6) Exhibits prepared by Grantee. All of the foregoing are incorporated fully herein by reference.

20. Public Record.

The Grantee acknowledges that the IEDC will not treat this Grant Agreement as containing confidential information and will post this Grant Agreement on the transparency portal as required by Executive Order 05-07 and IC § 5-14-3.5-2, as amended from time to time. Use by the public of the information contained in this Grant shall not be considered an act of the State.

21. Termination for Breach.

- A. Failure of the Grantee, for a Grantee Project, to complete the Project and expend Grant funds in accordance with this Grant Agreement may be considered a material breach

and shall entitle the IEDC to suspend Grant payments associated with said Project, and to suspend the Grantee's participation in State grant programs until such time as all material breaches are cured to the State's satisfaction.

- B. The Grantee shall require each Subrecipient to warrant to complete its Project and expend Grant funds in accordance with this Grant Agreement. Breach of said warranty shall entitle the IEDC to suspend Grant payments associated with said Project, and to suspend the Subrecipient's receipt of Grant funds.
- C. The expenditure of Grant funds other than in conformance with this Grant Agreement may be deemed a breach. The Grantee explicitly covenants that it shall within thirty (30) days repay to the IEDC all funds not spent in conformance with this Grant Agreement. If IEDC is subject to any fine, penalty or fee as a result of the Grantee's improper expenditure of Grant funds, the Grantee shall fully reimburse the IEDC for any incurred expense.

22. Termination for Convenience.

Unless prohibited by a statute or regulation relating to the award of the Grant, this Grant Agreement may be terminated, in whole or in part, by the IEDC whenever, for any reason, the IEDC determines that such termination is in the best interest of the State. Termination shall be effected by delivery to the Grantee of a Termination Notice, specifying the extent to which such termination becomes effective. The Grantee shall be compensated for completion of the Project properly done prior to the effective date of termination. The IEDC will not be liable for work on the Project performed after the effective date of termination. In no case shall total payment made to the Grantee exceed the original Grant. In all instances of termination for breach or for convenience, the subrecipient will be provided notice and an opportunity for a hearing according to 2 CFR 200.340 through 200.343, as amended from time to time.

23. Travel.

No expenses for travel will be reimbursed.

24. Provision Applicable to Grants with tax-funded State Educational Institutions: "Separateness" of the Parties.

The IEDC acknowledges and agrees that because of the unique nature of State Educational Institutions, the duties and responsibilities of the State Educational Institution in these Standard Conditions for Grants are specific to the department or unit of the State Educational Institution. The existence or status of any one contract or grant between the IEDC and the State Educational Institution shall have no impact on the execution or performance of any other contract or grant and shall not form the basis for termination of any other contract or grant by either party.

25. Assignment.

The Grantee shall not assign this Grant Agreement without advanced approval from IEDC. Unauthorized assignment is a material breach of this Grant Agreement.

26. Subrecipient Agreements.

After approval of a Claim Form by the IEDC, the Grantee may enter into “**Subrecipient Agreements**” with Subrecipients for an approved Project. The Grantee shall flow down all federal and State regulatory provisions and clauses that are herein or incorporated herein and applicable to Subrecipients. All elements required by 2 CFR § 200.332(a) shall be included in the subawards made by the Grantee.

27. Non-Waiver and Severability.

Failure of either party to insist upon strict performance of any term or condition herein or to exercise any rights or remedies shall not be construed as a waiver of that party’s right to assert any of the same or rely on any such term or condition at any time thereafter. Invalidation of any term, in whole or in part, shall not affect the validity of the other parts.

28. Non-Collusion, Acceptance.

The undersigned attests, subject to the penalties for perjury, that the undersigned is the Grantee, or that the undersigned is the properly authorized representative, agent, member, or officer of the Grantee. Further, to the undersigned’s knowledge, neither the undersigned nor any other member, employee, representative, agent, or officer of the Grantee, directly or indirectly, has entered into or been offered any sum of money or other consideration for the execution of this Grant Agreement other than that which appears upon the face hereof. **Furthermore, if the undersigned has knowledge that a state officer, employee, or special state appointee, as those terms are defined in IC § 4-2-6-1, has a financial interest in the Grant, the Grantee attests to compliance with the disclosure requirements in IC § 4-2-6-10.5, all as amended from time to time.**

29. Indemnification.

Unless due to the negligence the IEDC, the Grantee shall indemnify, defend, and hold harmless the IEDC and the State of Indiana and their respective agents, officers, employees and representatives from all third party claims and suits for loss or damage to property, including the loss of use thereof, and injuries to or death of persons, including without limitation any officers, agents, employees, and representatives of the Grantee or its subcontractor(s), and from all judgments recovered therefrom and for expenses in defending any such claims or suits, including court costs, attorneys’ fees, and for any other expenses caused by an act or omission of the Grantee and/or subcontractor(s), agents, officers, or employees in connection with performance of this Grant Agreement. The IEDC shall not provide such indemnification to Grantee.

30. Public Relations and Marketing.

All external facing communications related to this Grant and the Plan, including but not limited to marketing, public relations and social media materials and content, shall be developed in consultation with the IEDC and receive IEDC and Grantee written approval prior to publication. Communications should include appropriate reference to the IEDC as an investor, partner and/or sponsor of the program or initiative that is the subject of this Grant, including the use of the IEDC logo and IEDC social media tags and reference to IEDC social media accounts. All communications required under this paragraph shall be sent to READI@iedc.in.gov.

31. Use of the IEDC Name.

The IEDC has not granted any rights to use its name, trademark, intellectual property, or logos. The Grantee agrees that it will not use the name or intellectual property, including, but not limited to, IEDC trademarks or logos, in any manner, including commercial advertising or as a business reference without the prior written consent of the IEDC. In all cases in which the IEDC's participation will be referenced, the IEDC shall have the right of review and approval of the use, disclosure, and the finished product prior to its publication. All such requests shall be made in writing and delivered to the IEDC for approval at its sole discretion.

32. Obligations Limited to Grantee. Notwithstanding anything herein to the contrary, any obligation, duties or compliance responsibility set forth under this Grant Agreement on Grantee shall rest fully and solely with said Grantee entity and not be an obligation, duty or compliance responsibility of the individual volunteer, commissioner, board member, member, officer, agent, or representative serving said Grantee entity, except for any intentional malicious actions by such individual.

Signatures on Following Page -- Remainder of Page Intentionally Left Blank

In Witness Whereof, the Grantee and IEDC have, through duly authorized representatives, entered into this Grant Agreement. The parties, having read and understand the foregoing terms of this Grant Agreement, do by their respective signatures dated below hereby agree to the terms thereof.

REGIONAL OPPORTUNITY INITIATIVES, INC.



Signature

Printed Name and Position/Title
Date: 5/18/2022

INDIANA ECONOMIC DEVELOPMENT CORPORATION

David Rosenberg, Executive Vice President

(Digital Signature Stamp Below)



5.19.2022

STATE BUDGET AGENCY

 (for)

Zachary Q. Jackson
Director

Date: 06/22/2022

EXHIBIT B - CLAIM VOUCHER

Your Company Name

INVOICE

Street Address
 City, ST ZIP Code
 Phone 405.555.0190 Fax 405.555.0191

DATE: May 13, 2022
 Entity Invoice #
 IEDC Grant ID :
 Project #

Remit Via email to:
 Indiana Economic Development Corporation
processing@iedc.in.gov
 One North Capital Ave Suite 700
 Indpls IN 46204

IEDC USE ONLY	
Purchase Order #	
Invoice #	
Voucher #	

DESCRIPTION	AMOUNT
Itemized (provide budget categories if applicable)	
<u>Progress Report</u>	
TOTAL	

I am authorized to present this claim for reimbursement. I certify that the account is just and correct, that the amount claimed is legally due, after allowing all just credits, and that no part of the same has been paid.

Name: _____ Title: _____
 Signature: _____ Date: _____

EXHIBIT C

**State of Indiana American Rescue Plan Act
Coronavirus State and Local Recovery Funds**

CFDA: 21.027

Information and Questionnaire for Subrecipients

SUBRECIPIENT INFORMATION

Entity Name	Regional Opportunity Initiatives
Address	100 S. College Avenue, Suite 240, Bloomington, Indiana 47403

Contact Person:

Name	Tina Peterson
Email	tinapeterson@regionalopportunityinc.org
Phone Number	812-287-8116

Type of Entity

Approximate Total Entity-Wide Annual Operating Budget

	Previous Fiscal Year	Current Fiscal Year
Federal Funds	\$ 0.00	\$ 0.00
Non Federal Funds	\$ 2,862,196.00	\$ 4,790,657.00

Chief Executive and Staff, Tenure in Office

	Name	Years
Chief Executive Official	Tina Peterson, CEO & President	6+
Chief Financial Officer	Charlie Pride	1
Grant Program Manager	Maren Witte	2

GENERAL ASSESSMENTS

1. Is the entity new to operating or managing federal funds (has not done so within the past five years)?

Yes No

2. Has there been high staff turnover or agency reorganization that affects this program?

Yes No

3. Is staff assigned to the program experienced with managing federal funds?

Yes No

AUDIT REQUIREMENTS

1. Was the entity required to obtain a single audit for its most recently completed fiscal year?

Yes No

2. Did the entity obtain the required audit?

Yes No NA

3. Was the audit report free of findings?

Yes No NA

4. Were audit reports free of questioned costs?

Yes No NA

5. Was a corrective action plan required?

Yes No NA



CONSOLIDATED PROJECT REPORT

Project Details:

Region:	Regional Opportunities Initiative, Inc. (Indiana Uplands)	Grant ID Number:	423726
Project Name:	Hopewell: Jackson Street Design & Construction	Project ID:	00361
Project Type:	Other Infrastructure	Expenditure Category:	6. Revenue Replacement
Expenditure Sub-Category:	6.1 Provision of Government Services	Compliance Status:	Project Approved for Compliance
Last updated on:	02/23/2023	Created on:	01/17/2023

Project Information:

Project Information:

Project ID:	00361
Project Name:	Hopewell: Jackson Street Design & Construction
Project/Program Owner Type:	Public
Project Type:	Other Infrastructure
READI Focus Area:	Housing
READI Goal:	Quality of Place
READI Financial Request Dollar Amount (\$) (ARPA Project Dollar Amount):	\$ 1,800,000.00
Project Description (Long):	The City of Bloomington will use READI funds for the design and construction of a new 350-foot corridor in the 21-acre Hopewell development site, formerly the location of the IU Health Bloomington Hospital. READI funds will pay for engineering and design, roadway construction, utilities, and construction inspections. The brand new Jackson Street will directly support the redevelopment of the 1947 17,865 square foot Art-Deco Kohr Administration Building. The rental housing tax credit project will create 40 units of affordable housing, serving residents 60% and below Area Median Income. The Jackson Street artery will also support up to 400 housing units in the future on additional parcels. Jackson Street would connect to University Street, a main artery through the Hopewell project that will serve as a pedestrian and vehicle traffic corridor and as a centerpiece of public amenity space-- connecting the entire project site. The geographical boundaries is one block west of the corner of W. 1st Street and S. Rogers Street. Partners on the project include other City Departments such as Engineering, Public Works, and Planning and Transportation. Design and construction bidding will be done by the City of Bloomington Engineering Department through the City of Bloomington's procurement process. RFI Advertisement will be done on January 11, 2023, in April the design phase will begin, and in Spring 2024 construction will begin. Construction is scheduled to be completed by December 2024.
Project Description (Short):	The City of Bloomington will use READI funds for the design and construction of a new 350-foot corridor in the 21-acre Hopewell development site, formerly the location of the IU Health Bloomington Hospital. READI funds will pay for engineering and design, roadway construction, utilities, and construction inspections. The Kohr Administration Building project will be awarded a rental housing tax credit in the Fall of 2023 with construction beginning in the spring of 2024.
Project Description (Generic):	Other
Project Contact:	Maren Witte
Project Owner - Name/Company:	City of Bloomington - Housing & Neighborhood Development (HAND)
Legal Name (Region Name):	Regional Opportunities Initiative, Inc. (Indiana Uplands)
Counties Impacted:	Monroe County
Estimate Start Date:	01/11/2023

Estimate End Date:	12/31/2024
Primary Address:	<ul style="list-style-type: none"> •Address Line 1 :401 North Morton Street •Address Line 2 :Suite 130 •City :Bloomington •State :IN •Zip Code: 47404
Secondary Address:	

Financial Information:

Status:	Completed <50%
Obligated Amount:	\$ 1,800,000.00
Amount Pending Disbursement:	\$ 0.00
Amount Disbursed:	\$ 0.00
Leverage Amount:	\$ 7,958,776.00
Percent Leverage:	442.15 %



Construction Budget Template

**Please edit only the cells in white*

Summary	Source	Amount
	READI	\$ 1,800,000.00
	Public	\$ 5,039,130.00
	Private	\$ -
	Add'l Federal	\$ 2,919,646.00
	Add'l State	\$ -
	Total	\$ 9,758,776.00

Project Information	
Region	Bloomington
Project Name	Hopewell - Jackson St. Design and Construction
Submitted By (Name)	John Zody, City of Bloomington
Email Address	john.zody@bloomington.in.gov

Category	Activity	Sources					Total	
		READI	Public	Private	Add'l Federal	Add'l State		
Construction	Roadway Construction	\$ 775,000.00	\$ -	\$ -	\$ -	\$ -	\$ 775,000.00	
	Utilities	\$ 350,000.00	\$ -	\$ -	\$ -	\$ -	\$ 350,000.00	
	Construction Inspection	\$ 125,000.00	\$ -	\$ -	\$ -	\$ -	\$ 125,000.00	
			\$ -	\$ -	\$ -	\$ -	\$ -	
			\$ -	\$ -	\$ -	\$ -	\$ -	
			\$ -	\$ -	\$ -	\$ -	\$ -	
			\$ -	\$ -	\$ -	\$ -	\$ -	
			\$ -	\$ -	\$ -	\$ -	\$ -	
			\$ -	\$ -	\$ -	\$ -	\$ -	
			\$ -	\$ -	\$ -	\$ -	\$ -	
			\$ -	\$ -	\$ -	\$ -	\$ -	
			\$ -	\$ -	\$ -	\$ -	\$ -	
			\$ -	\$ -	\$ -	\$ -	\$ -	
Design	Engineering & Design	\$ 550,000.00	\$ -	\$ -	\$ -	\$ -	\$ 550,000.00	
			\$ -	\$ -	\$ -	\$ -	\$ -	
			\$ -	\$ -	\$ -	\$ -	\$ -	
			\$ -	\$ -	\$ -	\$ -	\$ -	
			\$ -	\$ -	\$ -	\$ -	\$ -	
Total by Category	(Match) Hopewell branding and marketing - consolidated TIF	\$ -	\$ 82,500.00	\$ -	\$ -	\$ -	\$ 82,500.00	
	(Match) Purchase agreement w/ IU Health (partial) - consolidated TIF	-	\$ 2,502,500.00	\$ -	\$ -	\$ -	\$ 2,502,500.00	
	(Match) Master Planning Process - consolidated TIF	\$ -	\$ 410,000.00	\$ -	\$ -	\$ -	\$ 410,000.00	
	(Match) 1st St. Reconstruction - consolidated TIF		\$ 2,030,025.00		\$ 2,919,646.00		\$ 4,949,671.00	
	(Match) Kohr Administration Redevelopment - consolidated TIF	\$ -	\$ 14,105.00	\$ -	\$ -	\$ -	\$ 14,105.00	
	Total by Category		\$ 1,800,000.00	\$ 5,039,130.00	\$ -	\$ 2,919,646.00	\$ -	
	Grand Total		\$					9,758,776.00



VIA EMAIL

February 23, 2023

Tina Peterson
President & CEO
Regional Opportunities Initiative, Inc.
Region ID: 423726
Sent via email to tinapeterson@regionalopportunityinc.org

Re: READI Project ID: 00361 – Hopewell: Jackson Street Design & Construction

Dear Tina Peterson,

The Indiana Economic Development Corporation (the “IEDC”) is pleased to inform the Regional Opportunities Initiative, Inc. (the “Region”) that the Hopewell: Jackson Street Design & Construction project (the “Project”) has been approved. We have been advised the Project, including associated Match investments, involves a total investment of approximately \$9,758,776.00 in Monroe County. The IEDC has reviewed and approved the Region’s proposed Project, and we are pleased to commit to the Region the following incentive package.

Regional Economic Acceleration & Development Initiative

The IEDC has obligated (\$1,800,000.00) in Regional Economic Acceleration & Development Initiative (READI) funds for the proposed project. The Project must be completed by December 31, 2026. The funding has been earmarked for this project and cannot be used for any other purposes.

If you have any questions regarding this approval letter, please don’t hesitate to contact me at (317) 234-3213, CAnderson@iedc.in.gov.

Sincerely,

A handwritten signature in black ink that reads "Chantel Anderson". The signature is written in a cursive, flowing style.

Chantel Anderson
READI Program Manager

Indiana Economic Development Corporation | 1 North Capitol Avenue, Suite 700 | Indianapolis, Indiana 46204
800.463.8081 | t 317.232.8800 | f 317.232.4146 | iedc.IN.gov

EXHIBIT B - CLAIM VOUCHER

City of Bloomington - HAND

INVOICE

401 N. Morton Street, Suite 130
 Bloomington, IN 47404
 Phone 812.349-3401

DATE: March 7, 2023
Entity Invoice #
IEDC Grant ID : 423726
Project #

Remit Via Grants Management Tool to:
 Indiana Economic Development Corporation
 One North Capital Ave Suite 700
 Indpls IN 46204

IEDC USE ONLY	
Purchase Order #	
Invoice #	
Voucher #	

DESCRIPTION	AMOUNT
Total Personnel Expenses	\$ -
Total Purchases	\$ -
Total Contractual Expenses	\$ -
<u>Progress Report</u>	
TOTAL	\$ -



Region	Indiana Uplands
Legal Name	Regional Opportunity Initiatives
Region ID	423726
Project ID	00361
Project Name	Hopewell: Jackson Street Design & Construction
Reimbursement Start Date	
Reimbursement End Date	
Assigned IEDC Regional Manager	Kurt Fullbeck

Request Reimbursement

Step 1: Fill out the three tabs highlighted in orange based on the type of expense you are seeking reimbursement for. Examples of the types of expenditures that should be included on each tab are listed below. Please note this list is not exhaustive; each disbursement request will be evaluated on a case by case basis.

Step 2: Complete Exhibit B Claim Voucher. Please note the expenditure amounts are prepopulated from the three orange tabs.

Step 3: Upload completed workbook into the GMT disbursement request.

Step 4: Upload required supporting documentation into the GMT disbursement request. Please see below for the documentation requirements.

Refer to section 4 and 6 of the IEDC Grant Agreement for the terms and conditions for reimbursement

Regions are required to maintain all supporting documentation, including evidence of vendor payment, for a minimum period of 5 years after the termination of the project. Refer to the record keeping requirements in the Compliance and Reporting Guidance.

Tab	Examples of which tab expenses should be recorded
Total Personnel Expenses	-Hours incurred for -program administration -project monitoring -reporting
Total Purchases	-Equipment -Materials -Construction labor costs -Indirect costs for administrative personnel
Total Contractual Expenses	-Rent -Contractors

List of required documentation to be submitted with each claim voucher based on the procurement threshold (as applicable):	
Purchases under \$10,000:	-Purchase order/Contract/ grant agreement * -Invoice -Proof of service
Purchases between \$10,000 and \$250,000:	-Minimum of 2 quotes * -Explanation for the selection * -Purchase order/contract/grant agreement * -Invoice -Proof of service
Purchases over \$250,000:	-Evidence that the bid was publicly solicited * -List of responses * -Selection scoring * -Purchase order/contract/grant agreement * -Invoice -Proof of service

*Procurement documentation only needs to be provided during the first disbursement request for each vendor.

Note: This tab is used to record the expenses related to personnel charges. Eligible expenses to be included in this section include: personnel expenses associated with administering the READI/ARPA program (both RDA personnel and fiscal agents), personnel expenses of consultants (legal, accounting, etc.), and personnel expenses associated with running programs (such as education or childcare programs).

Add rows as necessary.

Personnel Name	Company	Period of Performance	Invoice Number (if applicable)	Invoice Date	Hours	Rate	Description of tasks performed	READI Reimbursement Request	Additional Details

Total Request \$0.00

Instructions	
Period of Performance	Specify the period included in the invoice
Description of tasks	Be as detailed as possible

Note: This tab is used to record purchases or services.
Add rows as necessary.

Description of Purchase/Service	Vendor	Purchase Order # (if applicable)	Invoice Number (if applicable)	Invoice Date	Invoiced Amount	READI Allocation %	Discount / Reductions	READI Reimbursement Request	Additional Details

Total Request \$ -

Instructions	
READI Allocation %	Indicates if READI is only covering a portion of the total contract/invoice. Costs may be split with other departments or parties.
Discount / Reductions	Indicate is any discounts were applied (early payment discount, volume discount, etc.) Specify type of discount in Additional Details column

Note: This tab is used to record expenses incurred where an invoice isn't available on a monthly/quarterly basis but payment terms are dictated by a contract. For example, rent payments or fiscal agent payments which are a set amount each month and not based on volume.
Add rows as necessary

Vendor	Type of Contract	Contract Period	Total Contract Amount	Contract Terms	Reimbursement Period	Total Period Expense	READI Allocation %	Discount / Reductions	READI Reimbursement Request	Additional Details

Total Request \$ -

Instructions	
READI Allocation %	Indicates if READI is only covering a portion of the total contract/invoice. Costs may be split with other departments or parties.
Discount / Reductions	Indicate is any discounts were applied (early payment discount, volume discount, etc.)

PARCEL DIAGRAM
(1"=60')

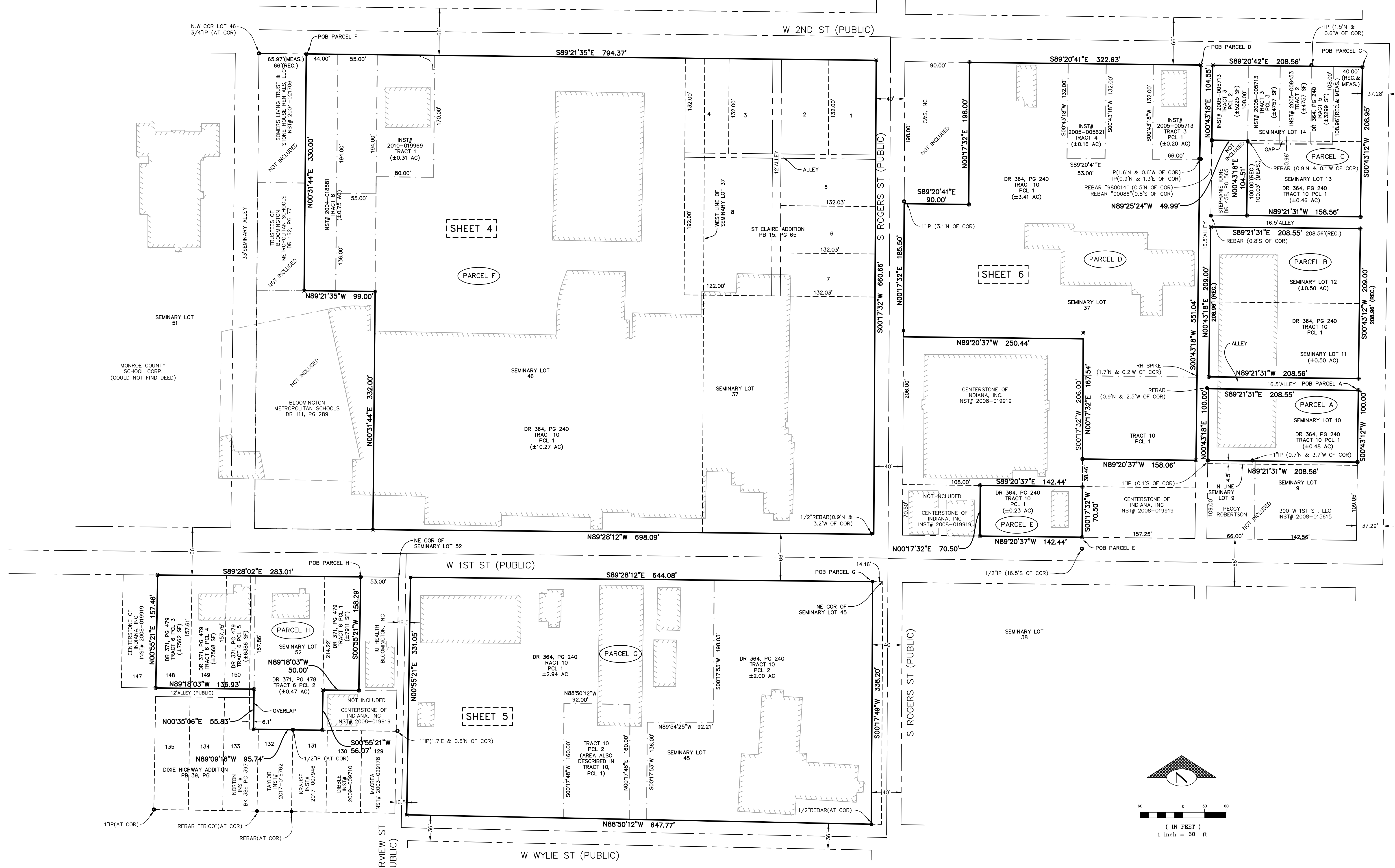

SHEET 4

SHEET 6

SHEET 5

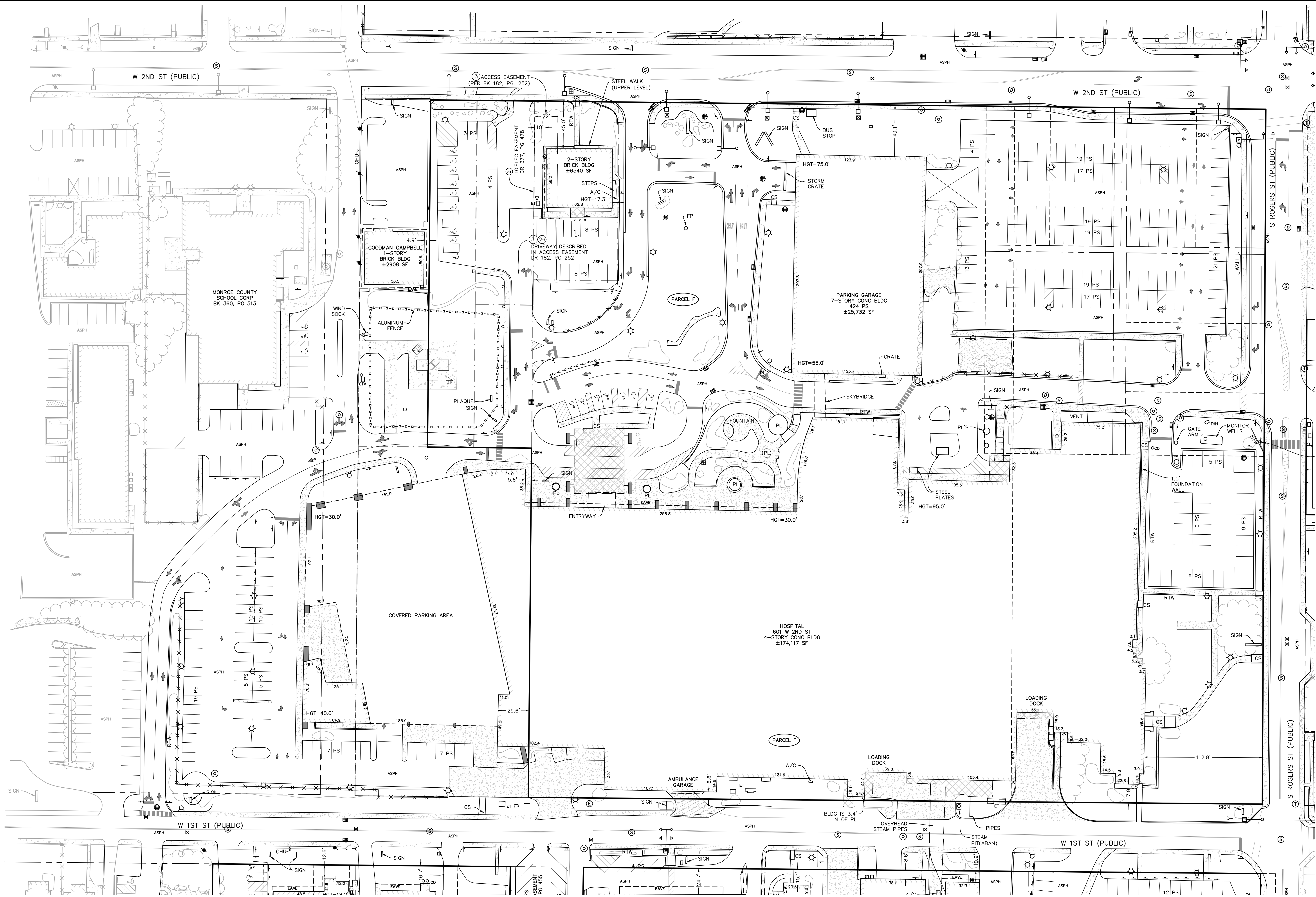

SEE SHEET 6

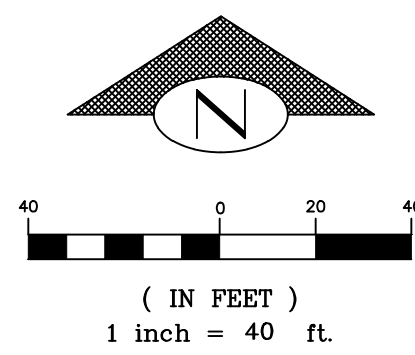

SEE SHEET 5

SEE SHEET 4

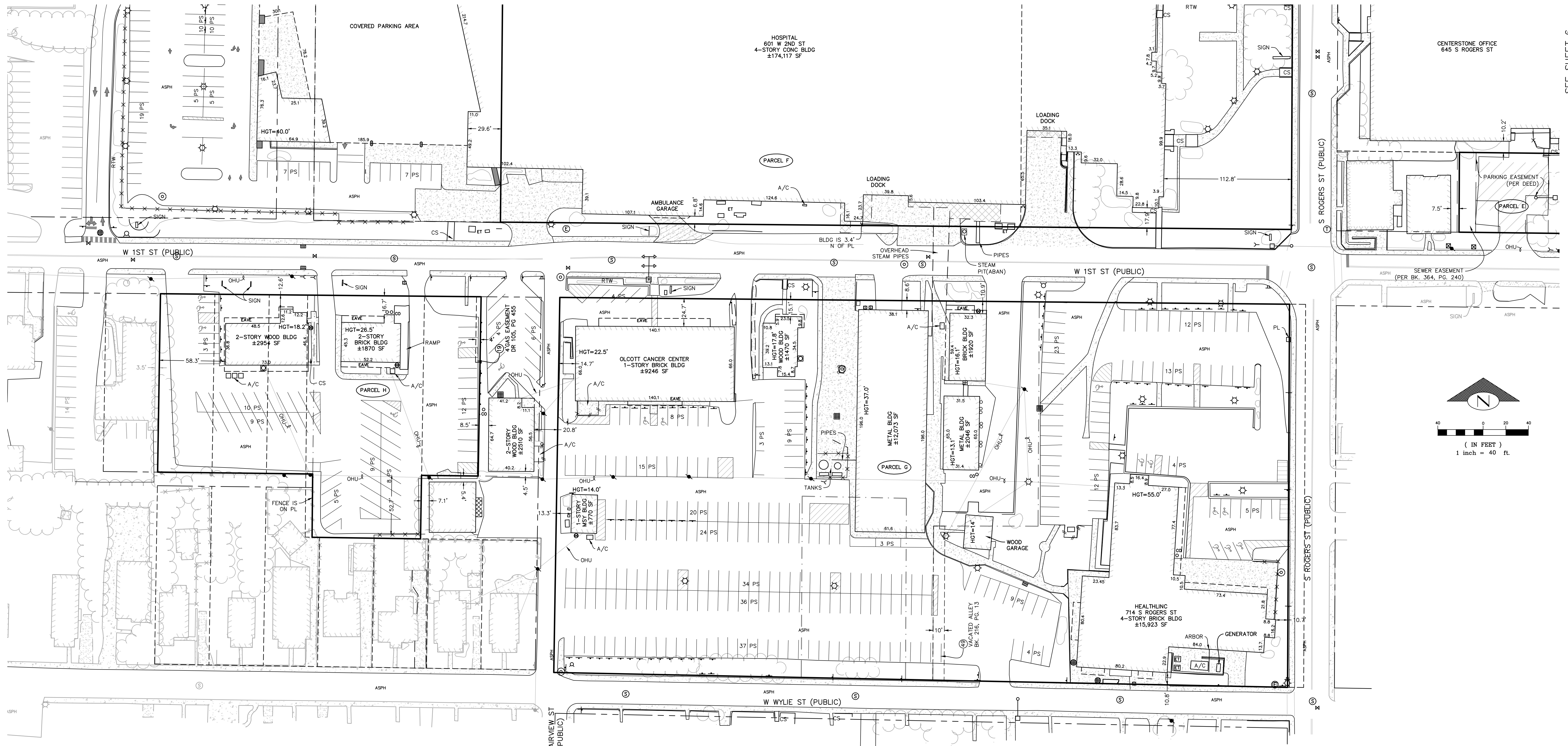

SEE SHEET 6

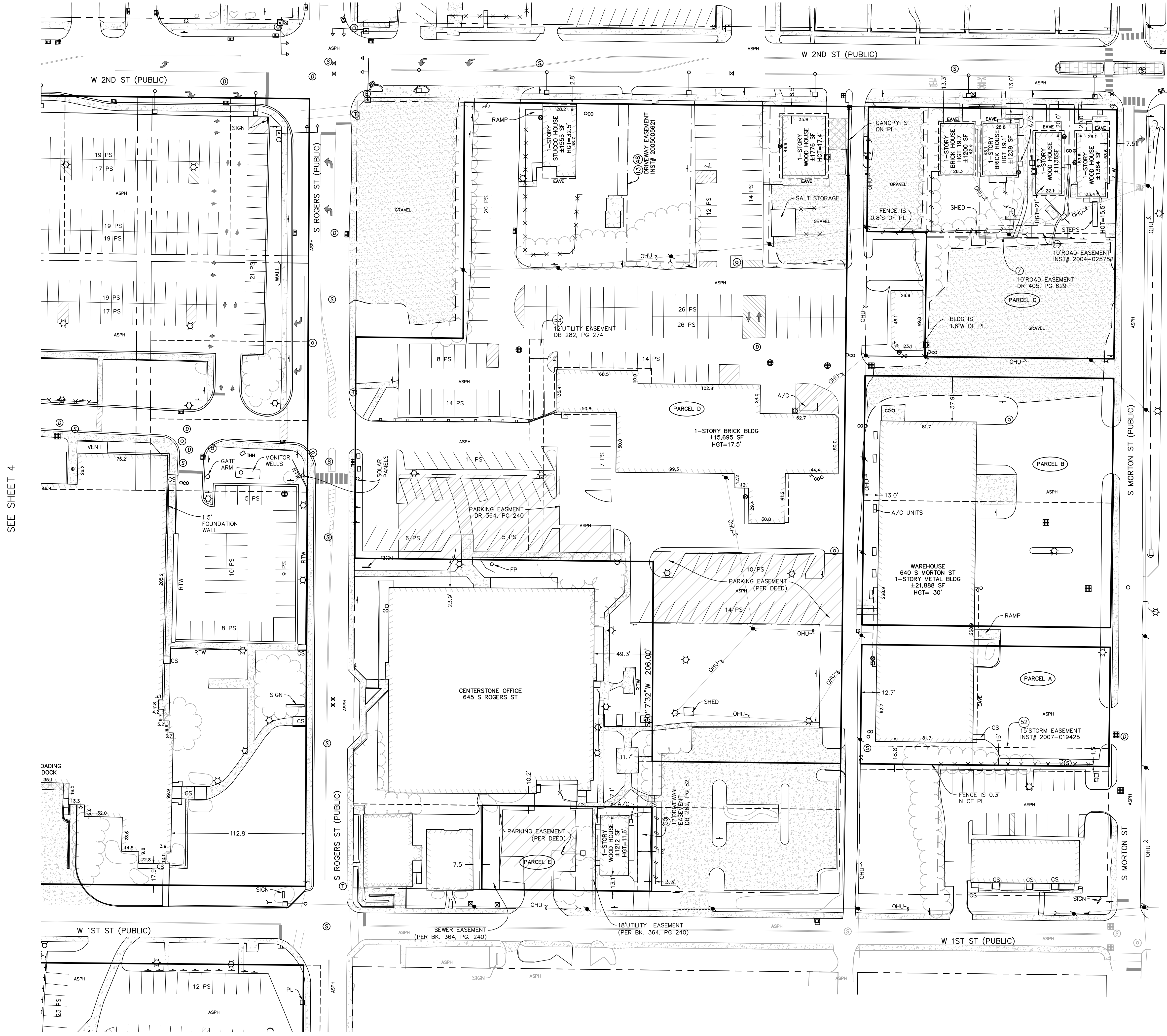

SEE SHEET 4

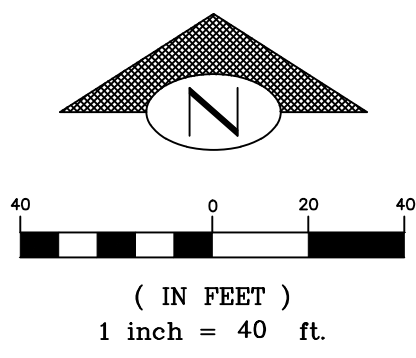

**State of Indiana American Rescue Plan Act
Coronavirus State and Local Recovery Funds**

CFDA: 21.027

Information and Questionnaire for Subrecipients

SUBRECIPIENT INFORMATION

Entity Name	
Address	

Contact Person:

Name	
Email	
Phone Number	

Type of Entity

Approximate Total Entity-Wide Annual Operating Budget

	Previous Fiscal Year	Current Fiscal Year
Federal Funds		
Non Federal Funds		

Chief Executive and Staff, Tenure in Office

	Name	Years
Chief Executive Official		
Chief Financial Officer		
Grant Program Manager		

GENERAL ASSESSMENTS

1. Is the entity new to operating or managing federal funds (has not done so within the past five years)?

Yes No

2. Has there been high staff turnover or agency reorganization that affects this program?

Yes No

3. Is staff assigned to the program experienced with managing federal funds?

Yes No

AUDIT REQUIREMENTS

1. Was the entity required to obtain a single audit for its most recently completed fiscal year?

Yes No

2. Did the entity obtain the required audit?

Yes No

3. Was the audit report free of findings?

Yes No

4. Were audit reports free of questioned costs?

Yes No

5. Was a corrective action plan required?

Yes No

**18-31
RESOLUTION
OF THE
REDEVELOPMENT COMMISSION
OF THE
CITY OF BLOOMINGTON, INDIANA**

**APPROVAL OF PURCHASE AGREEMENT BETWEEN THE CITY OF
BLOOMINGTON AND JU HEALTH FOR PURCHASE OF THE JU HEALTH
HOSPITAL SITE AT 2ND AND ROGERS STREETS**

WHEREAS, the Redevelopment Commission of the City of Bloomington ("RDC") is authorized to fund redevelopment of areas within the Consolidated TIF, and

WHEREAS, on December 26, 2017, the City of Bloomington ("City") signed a Letter of Intent with IU Health documenting the intent of the City to purchase the IU Health Bloomington Hospital site at 2nd and Rogers Street ("Old Hospital Site") from IU Health for the purpose of redevelopment; and

WHEREAS, in Resolution 18-10, the RDC approved a Project Review and Approval Form ("Form") for a project to envision reuse of the Old Hospital Site ("Project"), an element of which Form authorized the City to negotiate terms of purchase for the Old Hospital Site; and

WHEREAS, in Resolution 18-17, the RDC approved an agreement with the Urban Land Institute for consulting services related to envisioning redevelopment of the Old Hospital Site; and

WHEREAS, pursuant to Indiana Code § 36-7-14-19(b), two (2) independent appraisals were procured to determine the fair market value of the Old Hospital Site; and

WHEREAS, Staff has negotiated, and the Bloomington Common Council has approved subject to RDC approval, an agreement to purchase the Old Hospital Site for an amount not to exceed Six Million Five Hundred Thousand Dollars (\$6,500,000) ("Agreement"), which Agreement is attached as Exhibit A; and

WHEREAS, pursuant to Indiana Code §36-7-14-19(c)(1) and (2), the City Council must approve of any RDC purchases that exceed \$5 million and/or involve payments over a term exceeding three (3) years, and on April 18, 2018, the City Council approved the transaction in Resolution 18-06; and

WHEREAS, Resolution 18-10 identified the Consolidated TIF as the source of funds for the Project; and

WHEREAS, the RDC has available Consolidated TIF Funds to pay for the acquisition of the Old Hospital Site in accordance with the terms of the Agreement; and

WHEREAS, the City has brought the RDC an amended Form attached to this Resolution as Exhibit B; and

WHEREAS, it is in the public interest that the Agreement be undertaken and performed; and

NOW, THEREFORE, BE IT RESOLVED BY THE REDEVELOPMENT COMMISSION OF THE CITY OF BLOOMINGTON, INDIANA, THAT:

1. The RDC reaffirms its support of the Project, as set forth in the Form, and reiterates that it serves the public's best interests.
2. The RDC finds that the aboved described expenditure is an appropriate use of Consolidated TIF funds.
3. The RDC hereby approves the Agreement and the payment of an amount not to exceed Six Million Five Hundred Thousand Dollars (\$6,500,000) to be payable in accordance with the terms of the Agreement.

BLOOMINGTON REDEVELOPMENT COMMISSION



Donald Griffin, President

ATTEST:



Mary Alice Rickert, Secretary

5-7-18

Date

AGREEMENT FOR PURCHASE AND SALE OF REAL ESTATE
(Bloomington Campus)

THIS AGREEMENT FOR PURCHASE AND SALE OF REAL ESTATE (this "**Agreement**") is made this 21st day of May, 2018 (the "**Effective Date**") by and between THE CITY OF BLOOMINGTON, INDIANA (the "**City**"), by and through the Bloomington Redevelopment Commission (the "**RDC**", the City and the RDC together being sometimes referred to as the "**City Parties**") and INDIANA UNIVERSITY HEALTH BLOOMINGTON, INC., an Indiana nonprofit corporation d/b/a IU HEALTH ("**Seller**"). The term "**Party**" or "**Parties**" shall refer to the City, the RDC or Seller individually or collectively.

RECITALS

A. Seller owns real property in Bloomington, Indiana that is used for the operation of the IU Health Bloomington Hospital ("**Current Hospital**") and medical office and other facilities that support the Current Hospital (collectively, the "**Current Hospital Property**") that is depicted and described on Exhibit A, and depicted as Parcels A-D on Exhibit C.

B. Seller desires to relocate the Current Hospital and supporting facilities ("**New Hospital**") to a new campus in Bloomington, Indiana, located on real property that is depicted and described on Exhibit B (the "**New Hospital Property**"). In order to fully develop the New Hospital, Seller requires the City's assistance with certain infrastructure improvements.

C. The City Parties support the construction and development of the New Hospital and are willing to assist the Seller with certain infrastructure improvements that are required to fully develop the New Hospital.

D. The City Parties have determined it is in the best interest of the City's residents if the RDC purchases the Real Estate for future redevelopment projects, once the Seller removes certain agreed-upon buildings from the Current Hospital Property and transfers the Current Hospital operations to the New Hospital Property.

E. The City Parties and Seller desire to enter into this Agreement to facilitate the construction and development of the New Hospital and to secure the future redevelopment of the Current Hospital Property, subject to the mutual covenants, terms and conditions and agreements herein contained.

TERMS AND CONDITIONS

1. **Purchase and Sale.** Subject to the terms and conditions of this Agreement, the City Parties agree to purchase from Seller and Seller agrees to sell to the City Parties the Current Hospital Property, together with all improvements, privileges, easements and appurtenances pertaining thereto except as set forth herein (collectively, the "**Real Estate**").

2. **Covenants of the Parties.** Subject to the terms and conditions of this Agreement, the Parties agree to the following covenants.

a. The City Parties' Covenants.

i. Payment of Purchase Price. The purchase price for the Real Estate shall be Six Million Five Hundred Thousand and No/100 Dollars (\$6,500,000.00) (the "**Purchase Price**"). The City Parties shall pay the Purchase Price in the following manner: (1) \$1,500,000 to Seller upon execution of this Agreement by the parties (the "**Initial Payment**"), (2) \$2,500,000 at Closing (the "**Second Payment**"), provided that the Second Payment will be due no earlier than January 1, 2021, and (3) \$2,500,000 after January 1, 2022 and prior to December 31, 2025, in the sole discretion of the City Parties (the "**Third Payment**"). After Closing, in the event the City conveys, leases or otherwise transfers any portion of the Real Estate to a third party (a "**Transfer**") on or before the Third Payment is due, the greater of (i) the net consideration the City receives from the Transfer, and (ii) the prorata value (based on acreage) of such portion of the Real Estate that is transferred (using the Purchase Price as the base value of the entirety of the Real Estate), shall be paid to Seller until the obligation to pay the Purchase Price is satisfied. All portions of the Purchase Price shall be paid via wire transfer. The Second Payment shall be reduced by the amount of any traditional closing credits (i.e., by way of example and not limitation, rental revenue, utilities, expenses) (the "**Credit**" or "**Credits**") the City is entitled to receive under this Agreement at Closing.

ii. City's New Hospital Infrastructure Obligation. The City shall use good faith efforts to obtain 2019 and 2020 infrastructure funds from the State of Indiana (the "**Infrastructure Funds**") for the purpose of funding the construction of the following infrastructure improvements that Seller has determined are necessary for constructing and developing the New Hospital (collectively, the "**Infrastructure Improvements**"): (1) East 14th Street improvements (east of the 14th St & US 45/46 proposed interchange), as such improvements are described in Seller's New Hospital construction plans, and (2) 10th and Pete Ellis Drive intersection improvements, as such improvements are described in Seller's New Hospital construction plans. If the Infrastructure Funds are obtained, the City shall make such funds available to Seller in order to defray the costs of the Infrastructure Improvements. The Infrastructure Funds shall not be a Credit against the Purchase Price. The City Parties and Seller hereby agree to cooperate in good faith to identify and pursue other sources of state funding for this infrastructure work.

iii. New Hospital Zoning. City and Seller agree that the zoning district applicable to the New Hospital Property does not require City zoning review or approval for the New Hospital.

b. The Seller's Covenants.

i. Seller's Parcel A Obligations. Prior to Closing, the City Parties agree that Seller shall demolish all facilities (the "**Demolition**"), which are located on the portion of the Real Estate known as Parcel A identified on Exhibit C attached hereto and incorporated herein by reference, at its sole cost and expense (the "**Demolition Parcel**"), with the Parking Garage (as defined below) and Kohr Administration Building (as defined below) being the only exceptions thereto if the City Parties request such structures not be demolished in writing not later than one (1) year after the Effective Date (the "**Demolition**

Notice Period"). If the City Parties request that the Parking Garage remain, they shall be responsible for securing the structure and walkway opening post-Demolition, although Seller shall erect a rail in/on the Parking Garage next to the former walkway. The "**Parking Garage**" is the structure identified on Exhibit D attached hereto and incorporated herein by reference including those certain access drives identified thereon. The access drives to the Parking Garage shall be conveyed "AS IS". The "**Kohr Administration Building**" is the structure identified on Exhibit E attached hereto and incorporated herein by reference. Neither the Parking Garage nor the Kohr Administration Building shall be subject to Demolition until such time as the Demolition Notice Period shall have expired. Prior to Closing, Seller agrees to conduct any environmental remediation necessary as a result of the Demolition at its sole cost and expense (the "**Remediation**"). The City Parties agree to work in good faith to support Seller in facilitating any remediation processes; however, the City Parties shall in no event be responsible for any costs related to remediation. After the Demolition and any required Remediation have been completed in accordance with all laws, Seller shall deliver Parcel A with compaction and drainage standards as set forth in ASTM D 698 – Standard Test Methods for Laboratory Compaction Characteristics of Soils Using Standard Efforts, including capping utilities at the edge of the Parking Garage. Otherwise the Demolition Parcel shall be conveyed to the RDC at Closing in "AS IS" condition with the City Parties assuming all responsibility for the Parking Garage and Kohr Administration Building structures (if requested by the City Parties to remain). Notwithstanding the above, during the Due Diligence Period, and before the commencement of Demolition of either the Parking Garage or the Kohr Administration Building Seller and its engineers, at the request of the City Parties, shall meet on site with the City Parties and its representatives to set out the Demolition process and any procedures necessary to secure the Parking Garage and Kohr Administration Building during and after the Demolition of other structures and answer any questions.

ii. Seller's Parcel B, C and D Obligations. The parcels of Real Estate marked as B, C and D on Exhibit C shall be conveyed to the RDC at Closing in "AS-IS" condition. After the expiration of the Due Diligence Period, Seller shall not make, nor shall Seller permit, material changes to the physical conditions of the portions of the Real Estate identified on Parcels B, C and D on Exhibit C without the written consent of the City Parties, which shall not be unreasonably withheld, conditioned or denied.

iii. Seller's Obligation to Vacate the Real Estate. Seller shall have no obligation to convey or transfer title to the Real Estate until such time as (A) the Current Hospital has ceased all operations on the Current Hospital Property and the Seller has vacated the Real Estate, and (B) the New Hospital is open and accepting patients (together, the "**Vacation**").

iv. Completion of Site Conditions. Upon completion of the Demolition, Remediation and Vacation (collectively, the "**Site Conditions**"), Seller shall notify the City Parties in writing that the Site Conditions have been satisfied, which notice shall include written verification of the Demolition completion and Remediation completion from Seller's third party contractors or consultants (the "**Site Conditions Notice**"). The City Parties shall have forty-five (45) days from receipt of the Site Conditions Notice to independently verify (including obtaining environmental reports, if desired), at its sole cost and expense, the completion of the Site Conditions ("**City's Response Period**"). If the

City Parties do not provide written notice to Seller of any dispute regarding the Site Conditions within City's Response Period, the City Parties shall be deemed to have approved of the Site Conditions. If the City Parties provide written notice of any disputes with respect to the Site Conditions within City's Response Period, Seller shall have sixty (60) days to cure such defect or otherwise object to the City Parties' dispute notice ("**Seller's Response Period**"). If Seller and the City Parties are unable to come to an agreement in good faith with respect to the Site Conditions within thirty (30) days of the expiration of Seller's Response Period, the Parties agree to work together in good faith to resolve the outstanding issues with respect to the Site Conditions. If the Parties are unable to resolve the City's issue(s) with Site Conditions, then the Parties shall work together to select a mediator (such individual to be experienced in matters of commercial construction and demolition) (the "**Mediator**") who shall address the concerns of the City regarding the Site Conditions and to render a non-binding recommendation to the Parties regarding the Site Conditions. The cost of the Mediator shall be shared equally between Seller and the City Parties. In the event that either the Seller or the City is dissatisfied with the recommendations of the Mediator, then either of such Parties may, within ten (10) days of the decision of the Mediator and by written notice to the other Parties, terminate this Agreement, in which event the Initial Payment shall be returned within thirty (30) days thereafter from Seller to City and thereafter all other rights, obligations and conditions set forth in this Agreement shall be deemed to be terminated and of no further force and effect. In any event, the date upon which the Site Conditions are either (i) approved or deemed approved by the City Parties, or by the Mediator, or (ii) mutually agreed by the Parties, such date shall be considered the "**Site Condition Approval Date**".

v. Seller's Obligation to Convey the Real Estate. In all instances, Seller shall have no obligation to convey the Real Estate until such time as the Site Conditions have been satisfied in accordance with Section 2(b)(iv), above.

vi. Seller's New Hospital Infrastructure Obligations. Seller shall conduct and pay for all the design and construction work for the Infrastructure Improvements that include intersections and roadways (as determined by Seller), to ensure these locations are "shovel ready" and eligible for the Infrastructure Funds. Seller shall conduct and pay for all design work for the Infrastructure Improvements that include sewer extensions. Seller also agrees to provide the local one-to-one match necessary to receive the Infrastructure Funds. The City Parties and Seller hereby agree to cooperate in good faith to identify and pursue other sources of state funding for this infrastructure work.

3. Due Diligence.

a. Due Diligence Period. It is hereby understood and acknowledged by Seller that if the City Parties are unable to determine and/or obtain satisfactory results, as determined by the City Parties in their sole discretion, with respect to the matters specified in Section 3 on or before September 1, 2018 (the "**Due Diligence Period**"), the City Parties may, at their election and in their sole discretion, notify Seller in writing, at the place herein provided for notices, that they terminate this Agreement, in which case Seller shall return the Initial Payment to the City Parties and neither Party shall have further liability to the other arising out of this Agreement, except for such obligations as specifically survive termination of this Agreement.

b. Scope of the City's Diligence. On or before the expiration of the Due Diligence Period, the City must be able to determine the Real Estate complies with expectations, including each of the following matters during the Due Diligence Period:

i That the Real Estate is acceptable in all respects to the City, in the City's sole discretion, for the City Parties' contemplated use;

ii That ingress and egress for the Real Estate onto a public roadway is acceptable for the City Parties' contemplated use;

iii That the topography, soil consistency, geotechnical analysis and floodway designation of the Real Estate are acceptable for the City Parties' contemplated use; and

iv That the environmental conditions on the Real Estate, including wetlands and animal conservation issues, are satisfactory to the City Parties.

c. Environmental. The City Parties shall have the right, at their sole cost and expense, to obtain an environmental Phase I assessment (and/or any other assessment the City Parties deem necessary or appropriate including, but not limited to any Phase II or other further testing identified in the Phase I to examine recognized environmental conditions) for the Real Estate ("**Environmental Reports**"). The City Parties shall provide prior written notice to Seller of any scheduled on-site access to the Real Estate. In the event that the City Parties desire to conduct Phase II assessment or testing, the City Parties shall provide to the Seller for its reasonable approval the proposed consulting firm (to be mutually acceptable to the parties) together with its written protocol describing the scope of such Phase II testing including an insurance certificate naming Seller as an additional insured in appropriate form. The City Parties shall review such submittals and shall promptly and reasonably approve same. The City Parties' rights in this Section 3(c) shall include the right to obtain Environmental Reports for the interior of the Parking Garage pursuant to the terms and conditions herein.

d. Geotechnical. The City Parties shall have the right, at their sole cost and expense, to obtain a geotechnical assessment (or any other assessment the City Parties deem necessary or appropriate) for the Real Estate from a consulting firm acceptable to the City Parties.

e. Survey/Title.

i Seller shall obtain a satisfactory staked survey ("**Survey**") of the Real Estate, prepared in accordance with Minimum Standard Detail Requirements meeting the then current accuracy standards for ALTA/NSPS surveys, that includes the Table A items. The Survey shall be prepared and certified to the City Parties, Seller and First American Title Insurance Company, 211 N. Pennsylvania Street, Suite 1250, Indianapolis, IN 46204 (the "Title Company") as of a current date, by a registered engineer or surveyor satisfactory to Seller and the City Parties, and show the exact location of all improvements, utilities, building setback lines, easements, rights-of-way and encroachments affecting the Real Estate, and other matters apparent thereon and the relation of the Real Estate to all adjacent public thoroughfares. Further, the preparer must certify thereon whether the Real Estate or any portion thereof lies in an "area of special flood hazard" for purposes of the National Flood Insurance Program. The Survey description(s) (as well as any historical deed

description(s)) shall be used in the Deed (defined below) conveying the Real Estate from Seller to the RDC. In any event, the Survey shall be sufficient to cause the Title Company to delete the standard survey exceptions from the Title Policy described in Section 3(e)(iv) below. At Closing, the City Parties shall pay for ½ of the Survey costs.

ii Within ten (10) business days of the Effective Date, Seller shall provide the City Parties with a current ALTA standard title insurance commitment, issued by the Title Company, showing the condition of Seller's title to the Real Estate and any easements, restrictions, rights-of-way, agreements or other matters burdening and/or benefitting the Real Estate (the "**Title Commitment**"), together with commitments for any endorsements thereto, as reasonably requested by the City Parties.

iii The City Parties shall, on or before the expiration of the Due Diligence Period, notify Seller of any unacceptable physical or other defects disclosed in the Title Commitment or Survey. Seller shall have ten (10) days after receipt of such notice (or such longer period as reasonably necessary with written notice to the City) to cure or remove any such unacceptable defects, at Seller's sole cost and expense. If Seller is unable or unwilling to cure or remove such defects within said period, the City Parties may either (i) cancel and terminate this Agreement upon written notice to Seller, in which event the Seller shall return the Initial Payment to the City Parties and neither party shall have any further obligation under this Agreement, or (ii) waive such defects and proceed to Closing. Notwithstanding anything to the contrary in this Section 3(e)(iii), Seller shall have the obligation to cure (a) any exceptions to title that are either (i) mortgages, mechanics' and materialmen's liens evidencing monetary encumbrances or other liens (other than liens for non-delinquent real estate taxes) each to the extent created as a result of the intentional acts or omissions of Seller, its agents, affiliates or subcontractors that can be satisfied and discharged with the payment of a specified amount of money, or (ii) title matters created by Seller, its agents, affiliates or subcontractors in violation of the terms of this Agreement; and (b) any exception to title that Seller has specifically agreed in writing to remove pursuant to the terms of this Section 3(e)(iii).

iv Upon Closing, the RDC may elect to obtain an owner's policy of title insurance for the Real Estate (the "**Title Policy**") issued by the Title Company, in the amount of the Purchase Price (or any other amount the City Parties deem necessary, but which additional coverage amount shall be at the City Parties' cost and expense), showing good and marketable title in the Real Estate in the RDC, subject only to current taxes and assessments not then due and payable and, per the terms and conditions of this Agreement, any exceptions permitted in this Section 3(e)(iii). Any endorsements requested by the City Parties shall be at the City Parties' sole cost and expense.

f. Other Inspections. During the Due Diligence Period and through the Closing Date as provided for in Section 2(b)(iv) after the Site Conditions Notice, the City Parties and their agents and representatives shall have the continuing right to enter upon the Real Estate to make tests and inspections (physical or otherwise) necessary for evaluation of the Real Estate for the City Parties' contemplated use, such tests and inspections to include without limitation soil borings and surveys. All such tests and inspections made by the City Parties are to be made at the City Parties' sole cost and expense.

g. Seller's Documents. Seller shall, within thirty (30) days after the Effective Date, provide to the City Parties copies of all of the documents and other instruments affecting the Real Estate within its possession or reasonable control, including without limitation existing notices, environmental assessments and surveys ("**Seller's Documents**").

h. Liability. The City Parties shall be liable for any damage caused to the Real Estate or to any persons thereon by the City Parties' exercise of their inspection and access rights in this Section 3, and hereby agree to indemnify and hold harmless Seller from and against any such damage or injury or resulting claims and causes of action caused thereby, including reasonable costs and attorneys' fees.

4. Conditions Precedent. The Parties acknowledge and agree that each Party must obtain additional approvals in order to proceed with the Project (the "**Condition(s) Precedent**") which shall be satisfied no later than October 31, 2018 (the "**Condition Date**"). If any Condition Precedent is not resolved by the Condition Date, this Agreement shall terminate unless the Parties agree to extend the Condition Date. The Parties further acknowledge and agree their obligation to perform the obligations under this Agreement is contingent upon each Party's satisfaction or waiver of their respective Conditions Precedent by the Condition Date. The Parties agree to work reasonably and in good faith to satisfy the Conditions Precedent on or before the Condition Date.

a. The City Parties' Conditions Precedent. The following shall be the Conditions Precedent to the City Parties' obligations under this Agreement and with respect to the Project:

i. the City Parties determine in their sole discretion they can execute and perform their obligations under this Agreement in accordance with all statutory, regulatory, legal and other requirements that are applicable to the City Parties;

ii. the City Parties obtain all necessary approvals and consents which the City Parties determine in their sole and absolute discretion are necessary or advisable to comply with any and all laws, statutes, rules, regulations applicable to the City Parties' obligations under this Agreement; and

iii. the City Parties determine, in their sole and absolute discretion that neither they, nor Seller is subject to any injunction, preliminary restraining order or other similar decree of a court of competent jurisdiction prohibiting the consummation of the Project.

b. Seller's Conditions Precedent. The following shall be the Conditions Precedent to Seller's obligations under this Agreement and with respect to the Project:

i. Seller determines in its sole discretion it can execute and perform its obligations under the Agreement in accordance with all statutory, regulatory, procedural, and other legal requirements that are applicable to Seller and any Seller affiliates that may own portions of the Real Estate, including, but not limited to, the approval of this Agreement; and

ii. Seller obtains all necessary corporate, board, third-party and other approvals and consents, which Seller determines in its sole and absolute discretion are

necessary or advisable to comply with any and all laws, statutes, rules, and regulations applicable to the approval and terms of this Agreement.

c. **Failure to Satisfy a Condition Precedent.** If either party determines in its sole discretion it cannot satisfy, waive, or otherwise resolve one or more of its respective Conditions Precedent on or before the Condition Date, the party's sole remedy shall be to terminate this Agreement by written notice to the other party, in the event the parties shall have no further right or obligation under this Agreement (except for rights and obligations herein which expressly survive the termination of the Agreement).

5. **Taxes and Assessments.** Ad valorem real estate and similar taxes and assessments relating to the Real Estate ("**Impositions**") shall not be pro-rated by the parties as neither party is subject to Impositions; provided Seller shall have the obligation to satisfy any Impositions that are secured by liens against the Real Estate on or before Closing.

6. **Risk of Loss.** Seller shall bear the entire risk of loss until Closing. If, after the date hereof and prior to Closing, Seller receives notice of the commencement or threatened commencement of eminent domain or other like proceedings against the Real Estate or any portion thereof, Seller shall notify the City Parties within five (5) business days after Seller's knowledge of such proceedings, and the City Parties shall elect within ten (10) business days from and after such notice, by written notice to Seller, either: (i) not to close the transaction contemplated hereby in which case the City Parties shall be entitled to an immediate refund of the Initial Payment and this Agreement shall be null and void; or (ii) to close the transaction contemplated hereby in accordance with its terms but subject to such proceedings, in which event Seller shall assign its rights in any condemnation award or proceeds to the City Parties. If the City Parties do not make such election within the aforesaid ten (10) business day period, the City Parties shall be deemed to have elected to close the transaction contemplated hereby in accordance with Section 7 hereof.

7. **Closing.** Subject to the City Parties' rights to terminate this Agreement as provided herein, the transaction contemplated hereby shall be closed in the office of the Title Company (or some other suitable location mutually determined by the City Parties and Seller) or via escrow through the Title Company ("**Closing**"), on or before thirty (30) days after the Site Condition Approval Date but in no event earlier than January 1, 2021 (the "**Closing Date**"). In the event the Closing Date does not occur before January 31, 2021, the deadline for the City Parties' to pay the Third Payment shall be extended on a day for day basis for each day of delay in the Closing Date; provided the City Parties' shall have the right to terminate this Agreement with refund of the Initial Payment in the event Seller does not comply with its obligations in Section 2(b) on or before December 31, 2023. At Closing, Seller and the City Parties, as applicable, agree to deliver (or cause to be delivered) to the other party, in accordance with the terms of this Agreement, the following:

a. a Restrictive Covenant for recording immediately before the Deed (referenced in b. below) which provides for: (i) no subsequent transfer of the Real Estate shall be made to a hospital, health system or health care provider which competes with Seller without the prior written consent of Seller, which consent may be granted or denied in the sole discretion of Seller; (ii) the prohibition of use (through lease, transfer of ownership, or otherwise) of the Real Estate by a hospital, health system or health care provider which competes with Seller, unless

approved in advance in writing by Seller; (iii) the existence of the Third Payment obligation as set forth in Section 2(a)(i) herein; (iv) no new construction upon or any other use of the Real Estate prior to receipt by Seller of the Third Payment; and (v) maintenance of the Kohr Administration Building by City (if City Parties timely request that it not be demolished) in good condition, with emphasis on the appearance of the exterior elevation and grounds. Notwithstanding anything to the contrary in the previous sentence, the Restrictive Covenant described in Section 7(a)(iii) and (iv) shall only be recorded against and applicable to Parcel A described on Exhibit C.

b. a duly authorized and executed limited warranty deed to the RDC in recordable form, conveying marketable title to the Real Estate, subject only to current taxes not yet due and payable and, per the terms and conditions of this Agreement, any title exceptions permitted pursuant to Section 3(e)(iii) (the "**Deed**"). Seller, in any event, shall be obligated to remove at or prior to Closing all mortgages and other instruments or liens securing loans or other monetary obligations encumbering the Real Estate;

c. a duly authorized and executed Vendor's Affidavit in a form reasonably acceptable to the Title Company sufficient to remove all standard non-survey exceptions from the Title Policy;

d. an affidavit in a form satisfactory to the Title Company, stating that Seller is not a "foreign person", as such term is used in §1445 of the Internal Revenue Code;

e. Seller shall deliver bills of sale conveying title to any personal property on the Real Estate;

f. Seller shall deliver to the RDC all keys, remote control devices, passcodes, entry badges and other items required to access the Real Estate;

g. the Title Company shall deliver the Title Policy;

h. Seller and the RDC shall deliver a closing statement setting forth the Initial Payment, the Second Payment and all prorations, adjustments, debits, and Credits pursuant to the terms of this Agreement;

i. the RDC shall deliver the Second Payment, less any Credits due to the RDC pursuant to this Agreement;

j. Seller shall deliver to the RDC evidence that all Contracts have been terminated as of the Closing. As used in this Agreement, "**Contracts**" shall mean all of the contracts between Seller and/or its manager, all service and/or materials contracts, and all leases, which contracts and leases relate to the operation and maintenance of the Real Estate, true and complete copies of which are included in Seller's Documents; and

k. all other documents the City Parties or Seller reasonably deems necessary or appropriate to complete the transaction contemplated by this Agreement; including the Disclosure of Sales Information Form required by the State of Indiana.

8. Possession. Seller shall deliver exclusive possession of the Real Estate to the RDC at Closing in AS-IS condition; provided, however, the Demolition Parcel shall be delivered in "AS-IS" condition subject to the Demolition and Remediation requirements set forth in this Agreement.

9. Transfer Fees; Closing Costs. At Closing, Seller shall pay the cost of any state and/or local transfer, stamp, or other conveyance taxes or gross income tax upon the sale of the Real Estate to the RDC, in the amount required by law, and the recording costs associated with recording any documents necessary to cure any exceptions to title to which the RDC reasonably objects. At Closing, the RDC shall pay the nominal cost of recording the Deed and filing the Indiana Sales Disclosure Form. The premium and any related search fees for the Title Policy shall be paid solely by Seller at Closing. The costs and expenses for the endorsements to the Title Policy shall be paid by the RDC. The cost of any lender policy shall be paid by the RDC, and the insured closing fee of the Title Company and the Survey shall be split equally between Seller and the RDC at Closing. All other Closing costs and expenses shall be paid by the party incurring those costs and expenses, including without limitation attorneys' fees.

10. Operating Revenue and Expenses. All operating revenue and expenses associated with the Real Estate shall be allocated between Seller and the RDC as of the Closing Date, so that Seller pays that part of operating costs accrued through the Closing Date, and the RDC pays that part of operating costs accrued beginning on the day following the Closing Date. Rents and expenses for the Closing Date shall be allocated to Seller.

11. Commissions. The City Parties represent and warrant that they have dealt with no broker, finder or other person with respect to this Agreement or the transactions contemplated hereby. Seller represents and warrants that it has dealt with no broker, finder or other person with respect to this Agreement or the transactions contemplated hereby. Seller and the City Parties each agree to indemnify and hold harmless one another against any loss, liability, damage or claim incurred by reason of any other brokerage commission or finder's fee alleged to be payable because of any act, omission or statement of the indemnifying party. Such indemnity obligations shall be deemed to include the payment of reasonable attorneys' fees and court costs incurred in defending any such claim and shall survive the Closing hereof.

12. Agreements, Representations and Warranties of Seller. Seller represents, warrants and covenants to the City Parties as to the following matters, and shall be deemed to remake all of the following representations, warranties and covenants as of the Closing Date. The truth and accuracy of all of the following representations, warranties and covenants shall be conditions precedent to the City Parties' obligation to close under this Agreement, and all such representations, warranties and covenants shall survive the Closing or the termination of this Agreement. Seller agrees to indemnify and hold harmless the City Parties from and against any and all liability arising out of any of these representations or warranties being untrue or the breach of any of the covenants.

a. Validity of Agreement. Except as specifically provided herein, the entering into of this Agreement and the consummation of the sale of the Real Estate will not require Seller to obtain (either before or after the Closing) any consent, license, permit, waiver, approval, authorization or any other action of, by, or with respect to any non-governmental or governmental person or entity.

b. Legal Proceedings. There is no pending or, to the best of Seller's knowledge, threatened action or legal proceeding affecting the Real Estate or Seller's interest therein.

c. Access; Utilities. No fact or condition exists that would result in the termination or impairment of access to the Real Estate from adjoining private streets or ways or that could result in discontinuation of necessary sewer, water, electric, gas, telephone or other utilities or services.

d. Special Assessments. There are no public improvements that have been ordered to be made, and there are no special, general, or other assessments pending, threatened against, or affecting the Real Estate.

e. Transfer of Property. Prior to Closing, Seller shall not (i) enter into or modify any lease affecting the Real Estate other than various leases which may be modified or extended by Seller, in its sole and absolute discretion, but which leases shall terminate at or before Closing (collectively, the "Leases"), or (ii) encumber or transfer all or any part of the Real Estate without the City Parties' consent (other than to an affiliated entity, in which case the obligations of Seller under this Agreement will transfer to such affiliated entity). Seller warrants that, except for this Agreement, there are no purchase contracts, options, leases or any other agreements of any kind, oral or written, formal or informal, recorded or unrecorded, whereby any person or entity other than Seller will have acquired or will have any basis to assert any right, title, or interest in, or right to possession, use, enjoyment or proceeds of any part or all of the Real Estate other than the Leases.

f. Hazardous Waste. Seller is not providing any representations or warranties regarding environmental matters. The City Parties shall be responsible for performing its own investigations as to environmental matters. Seller will use its best efforts to provide any prior reports which it may be able to locate.

g. Cooperation. Seller, at no cost to Seller, shall cooperate with the City Parties as may be reasonably necessary in order to satisfy the City Parties' conditions in this Agreement, including signing such applications, consents and other documents and instruments as the City Parties may reasonably request in their efforts to satisfy such conditions and by making available to the City Parties all information that is related to the Real Estate in Seller's possession or control as and when required pursuant to the terms of this Agreement.

h. Contracts. Seller has not contracted for any services or employment and has made no commitments or obligations therefor which will bind the RDC as a successor-in-interest with respect to the Real Estate and all of the Contracts are terminable by Seller prior to Closing. All Contracts will be terminated as of the Closing Date so that there shall be no obligations under any Contracts that survive the Closing.

i. Further Covenants. Seller shall advise the City Parties of any knowledge Seller has or comes into with respect to a material adverse change to the Real Estate prior to Closing, failing of which, the same shall be deemed a breach of a warranty and representation without the ability in Seller to cure the same and thereafter, the City Parties shall have the right,

upon notice thereof to Seller on or prior to Closing, to terminate this Agreement, in which event the Title Company shall immediately return the Initial Payment to the City Parties and neither Party shall thereafter have any further liability or obligation hereunder except for such liabilities and obligations that are expressly stated herein to survive termination of this Agreement.

13. Agreements, Representations and Warranties of the City Parties. The City Parties represent, warrant and covenant to Seller as to the following matters, and shall be deemed to remake all of the following representations, warranties and covenants as of the Closing Date. The truth and accuracy of all of the following representations, warranties and covenants shall be conditions precedent to Seller's obligation to close under this Agreement, and all such representations, warranties and covenants shall survive the Closing or the termination of this Agreement. The City Parties agree to indemnify and hold harmless Seller from and against any and all liability arising out of any of these representations or warranties being untrue or the breach of any of the covenants.

a. Authority. This Agreement has been duly authorized, executed and delivered by the City Parties and is the legal, valid, and binding obligation of the City Parties enforceable against the City Parties in accordance with its terms, and the execution and delivery thereof does not violate any provision of any agreement or judicial order to which the City Parties are a party or to which the City Parties are subject; and that all the documents to be delivered by the City Parties to Seller at Closing will, at Closing, be duly authorized, executed and delivered by the City Parties and will be the legal, valid and binding obligations of the City Parties enforceable against the City Parties in accordance with their respective terms, and the execution and delivery thereof will not violate any provision of any agreement or judicial order to which the City Parties is a party or to which the City Parties is subject.

b. Validity of Agreement. Except as specifically provided herein, the entering into of this Agreement and the consummation of the purchase of the Real Estate will not require the City Parties to obtain (either before or after the Closing) any consent, license, permit, waiver, approval, authorization or any other action of, by, or with respect to any non-governmental or governmental person or entity.

14. Default.

a. Seller's Default. In the event that Seller fails to perform any of its obligations under this Agreement for any reason other than a City Party's default or the permitted termination of this Agreement by Seller or a City Party as expressly provided in this Agreement, the City Parties shall be entitled, following written notice to Seller and thirty (30) days, during which period Seller may cure the default, to (i) elect to terminate this Agreement by written notice to Seller (except for rights or obligations which expressly survive the termination of this Agreement and) and receive a return of the Initial Payment; (ii) seek the remedy of specific performance or other appropriate equitable remedy to obtain an order requiring Closing of the sale of the Real Estate upon the terms set forth in this Agreement; or (iii) waive the applicable default and continue the transactions contemplated by this Agreement.

b. The City Parties' Default. In the event that the City Parties fail to perform any of their obligations under this Agreement for any reason other than Seller's default or the

permitted termination of this Agreement by either Seller or the City Parties as expressly provided in this Agreement, Seller shall be entitled, following written notice to the City Parties and thirty (30) days, during which period the City Parties may cure the default, to: (i) elect to terminate this Agreement and retain the Initial Payment (and any other amounts received from the City Parties pursuant to this Agreement) if the City Parties' failure to perform occurs before Closing; (ii) seek AAA arbitration for timely resolution of the claim for payment in the event that the Third Payment is not made after the thirty (30) days cure period upon subsequent written notice to the City Parties; or (iii) file a petition for a writ of mandamus or seek other equitable relief from a court of competent jurisdiction with respect to the Third Payment or other sums that may be due herein, however, if such court rules by final judgment that such equitable remedy is not available, then and only then, Seller shall be entitled to a right of reverter for the Real Estate. To that end, if Seller is entitled to enforce a right of reverter, the Parties shall work together with good faith efforts to effectuate such right of reverter in a timely manner, it being agreed between the Parties to this Agreement that the actual damages to Seller in the event of such default are impractical to ascertain. Therefore, the Parties agree that a fair and equitable additional remedy in the event of enforcement of a right of reverter is that Seller shall return \$3,000,000 to the City Parties and the Seller shall retain the amount of \$1,000,000 for estimated interest costs, costs of collection, marketing and transaction costs. Any action Seller files to compel the City Parties to pay the Third Payment shall be filed in Marion County, Indiana as the exclusive venue for the payment matter and the City Parties waive any transfer to another venue or forum.

c. Punitive, Special, Consequential and Indirect Damages. Notwithstanding anything contained in this Section 14 to the contrary, for any and every default under or pursuant to or relating to this Agreement, the rights and remedies available to the aggrieved Party shall not include punitive, special, consequential, direct or indirect damages. The terms and provisions in this Section 14 shall indefinitely survive the Closing or the termination of this Agreement.

15. Notices. All notices, requests, demands, consents and other communications required or permitted under this Agreement shall be in writing and shall be deemed to have been duly and properly given on the date of service if delivered personally, or, if mailed, on the second day after such notice is deposited in a receptacle of the United States Postal Service, registered or certified mail, first class postage prepaid, return receipt requested, or on the first day after deposit with a nationally-recognized overnight delivery service (e.g., FedEx), or by e-mail to the e-mail addresses provided below (deemed duly and properly received on the date sent) in all events addressed appropriately as follows:

If to Seller: IU Health
Fairbanks Hall
340 W. 10th Street, Suite 2100
P.O. Box 1367
Indianapolis, IN 46206
Attn: John Huesing, Vice President & Treasurer
Email: jhuesing@IUHealth.org

IU Health
Fairbanks Hall
340 W. 10th Street, Suite 6100
P.O. Box 1367
Indianapolis, IN 46206
Attn: Mary Beth Claus, SVP & General Counsel
Email: mclaus@IUHealth.org

With a copy to: Bingham Greenebaum Doll LLP
2700 Market Tower
10 West Market Street
Indianapolis, Indiana 46204
Attn: Mary E. Solada, Esq.
Email: msolada@bgdlegal.com

If to the City: The City of Bloomington, Indiana
401 N. Morton Street, Suite 210
PO Box 1000
Bloomington, IN 47402
Attn: Mick Renneisen, Deputy Mayor
Email: renneism@bloomington.in.gov

With a copy to: The City of Bloomington, Indiana
401 N. Morton Street, Suite 210
PO Box 1000
Bloomington, IN 47402
Attn: Philippa M. Guthrie, Corporation Counsel
Email: guthriep@bloomington.in.gov

Either party may change its address for purposes of this Section by giving the other party written notice of the new address in the manner set forth above. Notice may also be given via electronic mail (i.e., e-mail), as well as by either party's legal counsel.

16. Assignment. This Agreement shall be binding upon and inure to the benefit of the respective heirs, representatives, successors and permitted assigns of the parties hereto; provided, however, that except as noted in the following sentences, neither party shall assign its rights or obligations under this Agreement to another individual or entity without the prior written consent of the other party. Notwithstanding the foregoing, Seller has the right to assign this Agreement to a related entity without the consent of the City Parties so long as such related party is the party in title to the Real Estate, written notice of the assignment is provided to the City Parties prior to Closing, and the Seller retains responsibility for the performance of the "Seller" obligations under this Agreement.

17. Entirety of Agreement. This Agreement embodies the entire agreement and understanding of the parties related to its subject matter and supersedes all prior proposals,

understandings, agreements, correspondence, arrangements and contemporaneous oral agreements relating to subject matter of this Agreement.

18. Amendments. This Agreement may be amended only by a written instrument signed by the City Parties and Seller.

19. Third Party Beneficiaries. This Agreement is for the benefit solely of the City Parties and Seller. No other person or entity shall be entitled to rely hereon or to anticipate the benefits hereof or to otherwise assert or be entitled to any rights as a third party beneficiary hereof.

20. Governing Law and Venue. This Agreement shall be governed by, construed and enforced in accordance with the laws of the State of Indiana. Seller and the City Parties irrevocably submit to the jurisdiction of the courts of Marion County, Indiana and waive any objection to the laying of venue in such courts or any claim that any such court is an inconvenient or improper forum.

21. Headings. Section titles or captions in this Agreement are included for purposes of convenience only and shall not be considered a part of the Agreement in construing or interpreting any of its provisions. All references in this Agreement to Sections shall refer to Sections of this Agreement unless the context clearly otherwise requires.

22. Lists. When used in this Agreement, "including" has its commonly accepted meaning associated with such word and any list of items that may follow such word are illustrative and are not be deemed to represent a complete list of the contents of the referent of the subject.

23. Preparation of Agreement. The parties have participated jointly in the negotiation and drafting of this Agreement. If any ambiguity or question of intent or interpretation arises, no presumption or burden of proof shall arise favoring or disfavoring any party by virtue of the authorship of any of the provisions of this Agreement.

24. Numbers; Pronouns. Unless the context otherwise requires, when used in this Agreement, the singular shall include the plural, the plural shall include the singular, and all pronouns shall be deemed to refer to the masculine, feminine or neuter, as the identity of the person or persons may require.

25. Attorneys' Fees. Notwithstanding anything to the contrary in this Agreement, in the event that either Seller or the City Parties, as the case may be, shall bring an action against the other party for breach of such party's obligations under this Agreement, the losing party shall pay the prevailing party's costs and expenses incurred in connection with such litigation, including without limitation reasonable attorneys' fees. The "prevailing party" shall be determined by the court hearing such matter.

26. Counterparts, PDF and Facsimile Signatures. This Agreement may be executed in counterparts, each of which shall be considered an original. To further facilitate the execution of this Agreement, the parties agree that they will give legal effect to facsimile signatures as if such signatures originally appeared on counterpart copies of this Agreement.

27. Confidentiality. This Agreement is being made in reliance that this Agreement, the negotiations contemplated by this Agreement and other confidential information provided by the City Parties or Seller to the other party will be treated by their respective directors, officers, employees, advisors, agents and representatives in the strictest confidence. Except as required by law or under the Indiana Access to Public Records Act, the Indiana Open Door Law or any other similar public records law (collectively, "Public Records Request"), neither the City Parties nor Seller shall transmit any document obtained by such party in connection with this Agreement or any other such transactions or dealings to any third party except to government agencies, prospective purchasers and tenants, and such party's counsel, consultants, lenders, and other advisors engaged to help such party in connection with the same (collectively, the "**Permitted Parties**") on a need to know basis, provided such Permitted Parties are advised of the confidentiality. Each party agrees to indemnify and hold the other party harmless from and against any loss, injury, damage, claim, lien, cost or expense, including reasonable attorneys' fees, arising from a breach of the foregoing.

28. Public Announcements. From Effective Date through the Closing Date, no public announcement or other dissemination of information regarding this Agreement shall be released or published without the prior written consent of the other party; provided that either Seller or the City Parties may make any release or publication as may be required by any lender or investor reporting requirements, Public Records Request, applicable law, rule, regulation or order binding on the party making the disclosure, and if such party is so obligated, the disclosing party shall, except in the case of any disclosure to any lender or investor, give prior notice thereof to the other party, shall cooperate with the other party to prepare a mutually acceptable disclosure, and shall provide a copy thereof to the other contemporaneously with the release or publication.

29. Seller's Right to Solicit Offers. Seller shall not have the right to list or market the Real Estate for sale or otherwise solicit any offers, directly or indirectly, during the term of this Agreement unless there is an event of default under this Agreement by the City Parties.

[REMAINDER OF PAGE INTENTIONALLY LEFT BLANK]
[SIGNATURE PAGE FOLLOWS]

IN WITNESS WHEREOF, the parties hereto, intending to be legally bound hereby, have executed this Agreement as of the Effective Date.

"CITY"

THE CITY OF BLOOMINGTON, INDIANA

By: 
Printed: John Hamilton
Title: Mayor

"RDC"

THE CITY OF BLOOMINGTON, INDIANA,
by and through the Bloomington Redevelopment Commission

By: 
Printed: David Griffith
Title: President

"SELLER"

INDIANA UNIVERSITY HEALTH BLOOMINGTON, INC.,
an Indiana nonprofit corporation

By: 
Brian Shockney, Interim President
Indiana University Health South Central Region

Approved and acknowledged by:

INDIANA UNIVERSITY HEALTH, INC.,
an Indiana nonprofit corporation

By: 
Dennis Murphy
President and Chief Executive Officer

EXHIBIT A

Real Estate

TRACT 1:

A PART OF SEMINARY LOT NUMBER 46 IN THE CITY OF BLOOMINGTON, INDIANA BOUNDED AND DESCRIBED AS FOLLOWS TO WIT: BEGINNING AT A POINT 10 RODS EAST OF THE NORTHWEST CORNER OF SAID SEMINARY LOT AND RUNNING THENCE SOUTH 170 FEET, THENCE EAST 80 FEET, THENCE NORTH 170 FEET, THENCE WEST 80 FEET TO THE BEGINNING.

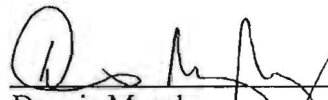
EXCEPTING THEREFROM A PART OF SEMINARY LOT 46, IN THE CITY OF BLOOMINGTON, INDIANA DESCRIBED AS FOLLOWS: BEGINNING AT A POINT 245.00 FEET EAST OF THE NORTHWEST CORNER OF SAID SEMINARY LOT 46, THENCE SOUTH FOR A DISTANCE OF 20.10 FEET, THENCE WEST FOR A DISTANCE OF 2.47 FEET, THENCE NORTH FOR A DISTANCE OF 3.06 FEET TO THE POINT OF CURVATURE OF A CURVE TO THE LEFT HAVING A RADIUS OF 12.60 FEET, SAID POINT OF CURVATURE BEING 12.60 FEET EAST OF THE RADIUS POINT OF SAID CURVE, THENCE NORTHWESTERLY OVER AND ALONG SAID CURVE FOR A DISTANCE OF 15.70 FEET TO A POINT ON SAID CURVE THAT STANDS 12.60 FEET NORTH 18 DEGREES 36 MINUTES 25 SECONDS EAST OF THE RADIUS POINT OF SAID CURVE, THENCE NORTH 68 DEGREES 56 MINUTES 53 SECONDS WEST, NON-TANGENT TO THE LAST DESCRIBED CURVE, FOR A DISTANCE OF 14.20 FEET TO THE NORTH LINE OF SAID SEMINARY LOT 46, THENCE EAST OVER AND ALONG SAID NORTH LINE FOR A DISTANCE OF 24.30 FEET TO THE POINT OF BEGINNING.

TOGETHER WITH A NON-EXCLUSIVE EASEMENT OVER AND ACROSS THE FOLLOWING DESCRIBED REAL ESTATE AS A MEANS OF INGRESS AND EGRESS TO AND FROM THE ABOVE DESCRIBED REAL ESTATE AND WEST SECOND STREET IN THE CITY OF BLOOMINGTON, INDIANA: BEGINNING AT A POINT 165 FEET EAST OF THE NORTHWEST CORNER OF SAID SEMINARY LOT 46, RUNNING THENCE SOUTH 170 FEET; RUNNING THENCE WEST 22 FEET; RUNNING THENCE NORTH 170 FEET; RUNNING THENCE EAST 22 FEET TO THE PLACE OF BEGINNING, BEING RECORDED IN DEED RECORD BOOK 182, PAGES 252-253, IN THE OFFICE OF THE RECORDER OF MONROE COUNTY, INDIANA.

TOGETHER WITH ANY AND RIGHTS OF THE GRANTOR IN AND TO A CERTAIN EASEMENT FOR DRIVEWAY, ENTERED INTO BY BLOOMINGTON MEDICAL SPECIALISTS BLDG., INC., AND EVA R. BROWN ON THE 13TH DAY OF DECEMBER 1967, SAID EASEMENT BEING RECORDED ON PAGES 252-253 IN DEED RECORD NUMBER 182 OF THE RECORDS ON FILE IN THE OFFICE OF THE RECORDER OF MONROE COUNTY, INDIANA.

TRACT 2:

A PART OF SEMINARY LOTS NUMBERED THIRTEEN (13) AND FOURTEEN (14) IN BLOOMINGTON, INDIANA, BOUNDED AND DESCRIBED AS FOLLOWS: COMMENCING ON THE NORTH LINE OF SAID SEMINARY LOT #14 AT A POINT 94 FEET EAST OF THE NORTHWEST CORNER THEREOF, THENCE EAST ON SAID NORTH LINE 44 FEET, THENCE SOUTH ON A LINE PARALLEL WITH THE WEST LINE OF SAID LOTS #13 AND #14, 108 FEET, THENCE WEST ON A LINE PARALLEL WITH THE NORTH LINE OF SAID LOT #14, 44 FEET, THENCE NORTH ON A LINE PARALLEL WITH THE WEST LINES OF SAID LOTS #13 AND #14 TO THE PLACE OF BEGINNING.

TRACT 3:

PARCEL I:

A PART OF SEMINARY LOT NUMBER THIRTY-SEVEN (37) IN THE CITY OF BLOOMINGTON, MONROE COUNTY, STATE OF INDIANA, BOUNDED AND DESCRIBED AS FOLLOWS, TO-WIT:

BEGINNING AT THE NORTHEAST CORNER OF SAID SEMINARY LOT THIRTY-SEVEN (37), RUNNING THENCE SOUTH ONE HUNDRED THIRTY-TWO (132) FEET, THENCE WEST SIXTY-SIX (66) FEET, THENCE NORTH ONE HUNDRED THIRTY-TWO (132) FEET, THENCE EAST SIXTY-SIX (66) FEET TO THE PLACE OF BEGINNING.

PARCEL II:

PART OF SEMINARY LOT NUMBER FOURTEEN (14) IN THE CITY OF BLOOMINGTON, INDIANA, BOUNDED AND DESCRIBED AS FOLLOW, TO-WIT: BEGINNING AT THE NORTHWEST CORNER OF SAID SEMINARY LOT NUMBER FOURTEEN (14), THENCE RUNNING SOUTH OVER AND ALONG THE WEST LINE OF SEMINARY LOT FOURTEEN (14) FOR A DISTANCE OF ONE HUNDRED FOUR AND FIVE TENTHS (104.5) FEET, AND TO THE SOUTHWEST CORNER OF SEMINARY LOT FOURTEEN (14); THENCE EAST OVER AND ALONG THE SOUTH LINE OF SAID SEMINARY LOT FOR A DISTANCE OF FIFTY (50) FEET; THENCE NORTH AND PARALLEL TO THE WEST LINE OF SAID LOT FOR A DISTANCE OF ONE HUNDRED FOUR AND FIVE TENTHS (104.5) FEET AND THE NORTH LINE OF SAID LOT, THENCE WEST FIFTY (50) FEET TO THE PLACE OF BEGINNING.

PARCEL III:

PART OF SEMINARY LOTS NUMBER THIRTEEN (13) AND FOURTEEN (14) IN THE CITY OF BLOOMINGTON, INDIANA DESCRIBED AS FOLLOWS: COMMENCING ON THE NORTH LINE OF SAID SEMINARY LOT NUMBER FOURTEEN (14), FIFTY (50) FEET EAST OF THE NORTHWEST CORNER, THENCE EAST ON SAID NORTH LINE FORTY-FOUR (44) FEET; THENCE SOUTH ON A LINE PARALLEL WITH THE WEST LINE OF SAID LOTS 13 AND 14, ONE HUNDRED EIGHT (108) FEET; THENCE WEST ON A LINE PARALLEL WITH THE NORTH LINE OF SAID SEMINARY LOT 14, FORTY-FOUR (44);

THENCE NORTH ON A LINE PARALLEL WITH THE WEST LINE OF SAID LOTS 13 AND 14; ONE HUNDRED EIGHT (108) FEET TO THE PLACE OF BEGINNING.

TRACT 4:

A PART OF SEMINARY LOT NUMBER THIRTY-SEVEN (37) IN THE CITY OF BLOOMINGTON, INDIANA, BOUNDED AND DESCRIBED AS FOLLOWS, TO-WIT: BEGINNING AT A POINT ONE HUNDRED THIRTY-TWO (132) FEET WEST OF THE NORTHEAST CORNER OF SAID SEMINARY LOT NUMBER THIRTY-SEVEN (37); THENCE WEST FIFTY-THREE (53) FEET, THENCE SOUTH ONE HUNDRED THIRTY-TWO (132) FEET; THENCE EAST FIFTY-THREE (53) FEET; TO A POINT ONE HUNDRED THIRTY-TWO FEET WEST OF THE EAST LINE OF SAID SEMINARY LOT NUMBER THIRTY-SEVEN (37); THENCE NORTH ONE HUNDRED THIRTY-TWO (132) FEET TO THE PLACE OF BEGINNING.

SUBJECT TO AN EASEMENT FOR A RIGHT OF WAY AND PRIVATE DRIVEWAY TWO (2) FEET IN WIDTH, IN, OVER, AND ALONG THE FOLLOWING DESCRIBED REAL ESTATE TO-WIT:

BEGINNING AT A POINT ONE HUNDRED EIGHTY-FIVE FEET WEST OF THE NORTHEAST CORNER OF SAID SEMINARY LOT THIRTY-SEVEN (37), RUNNING THENCE SOUTH SEVENTY-SIX AND ONE-HALF (76.5) FEET, THENCE EAST TWO (2) FEET, THENCE NORTH SEVENTY SIX AND ONEHALF (76.5) FEET, THENCE WEST TWO (2) FEET TO THE PLACE OF BEGINNING.

ALSO AN EASEMENT FOR A RIGHT OF WAY AND PRIVATE DRIVEWAY SIX (6) FEET IN WIDTH, IN, OVER, AND ALONG THE FOLLOWING DESCRIBED REAL ESTATE TO-WIT: BEGINNING AT A POINT ONE HUNDRED EIGHTY FIVE (185) FEET WEST OF THE NORTHEAST CORNER OF SAID SEMINARY LOT NUMBER THIRTY-SEVEN (37), RUNNING THENCE WEST SIX (6) FEET, THENCE SOUTH SEVENTY-SIX AND ONE-HALF (76.5) FEET, THENCE EAST SIX (6) FEET, THENCE NORTH SEVENTY-SIX AND ONE-HALF (76.5) FEET TO THE PLACE OF BEGINNING.

TRACT 5:

A PART OF SEMINARY LOTS THIRTEEN (13) AND FOURTEEN (14) IN THE CITY OF BLOOMINGTON, INDIANA, BOUNDED AND DESCRIBED AS FOLLOWS, TO-WIT: COMMENCING AT A POINT ONE HUNDRED THIRTY-EIGHT (138) FEET EAST OF THE NORTHWEST CORNER OF SEMINARY LOT FOURTEEN (14), RUNNING THENCE EAST THIRTY (30) FEET, THENCE SOUTH ON A LINE PARALLEL WITH THE WEST LINE OF SEMINARY LOTS THIRTEEN (13) AND FOURTEEN (14) ONE HUNDRED EIGHT (108) FEET, TO THE PLACE OF BEGINNING.

TRACT 6:

PARCEL I:

PART OF SEMINARY LOT #52 IN THE CITY OF BLOOMINGTON, INDIANA, BOUNDED AND DESCRIBED AS FOLLOWS, TO WIT: COMMENCING AT A POINT ON THE NORTH BOUNDARY LINE OF SAID SEMINARY LOT, SAID POINT BEING 53 FEET WEST OF THE NORTHEAST CORNER THEREOF, AND RUNNING THENCE SOUTH FOR A DISTANCE OF 158 FEET, RUNNING THENCE WEST FOR A DISTANCE OF 50 FEET; RUNNING THENCE NORTH FOR A DISTANCE OF 158 FEET AND TO THE NORTH BOUNDARY LINE OF SAID SEMINARY LOT, AND RUNNING THENCE EAST 50 FEET TO THE PLACE OF BEGINNING.

PARCEL II:

PART OF SEMINARY LOT NUMBER FIFTY-TWO (52) IN THE CITY OF BLOOMINGTON, INDIANA, AS FOLLOWS TO-WIT: COMMENCING AT A POINT SIX AND ONE-FOURTH (6 ¼) POLES WEST OF THE NORTHEAST CORNER OF SAID SEMINARY LOT NUMBER FIFTY-TWO (52), RUNNING THENCE WEST SIX AND ONE-FOURTH (6 ¼) POLES; THENCE SOUTH THIRTEEN (13) POLES, THENCE EAST SIX AND ONE-FOURTH (6 ¼) POLES; THENCE NORTH THIRTEEN POLES TO THE PLACE OF BEGINNING.

PARCEL III:

LOT NUMBER ONE HUNDRED FORTY-EIGHT (148) IN THE DIXIE HIGHWAY ADDITION IN THE CITY OF BLOOMINGTON, INDIANA.

PARCEL IV:

LOT NUMBER ONE HUNDRED FORTY-NINE (149) IN THE DIXIE HIGHWAY ADDITION IN THE CITY OF BLOOMINGTON, INDIANA.

PARCEL V:

LOT NUMBER ONE HUNDRED FIFTY (150) IN THE DIXIE HIGHWAY ADDITION IN THE CITY OF BLOOMINGTON, INDIANA.

TRACT 7: [INTENTIONALLY NOT INCLUDED]

TRACT 8:

PART OF SEMINARY LOT NUMBER 46 IN THE CITY OF BLOOMINGTON, INDIANA, BOUNDED AS FOLLOWS, TO-WIT: BEGINNING AT A POINT 66 FEET EAST OF NORTHWEST CORNER OF SAID SEMINARY LOT, RUNNING THENCE EAST 44 FEET, THENCE SOUTH 20 RODS, THENCE WEST 44 FEET, THENCE NORTH TO THE PLACE OF BEGINNING.

ALSO, A PART OF SEMINARY LOT NUMBER 46 IN THE CITY OF BLOOMINGTON, INDIANA, BOUNDED AND DESCRIBED AS FOLLOWS, TO-WIT: BEGINNING AT A POINT 110 FEET EAST AND 194 FEET SOUTH OF THE NORTHWEST CORNER OF SEMINARY LOT NUMBER 46, AND RUNNING THENCE SOUTH 137 FEET, MORE OR LESS, AND TO A POINT 20 RODS SOUTH OF SECOND STREET, THENCE EAST 55 FEET, THENCE NORTH 137 FEET, MORE OR LESS, AND TO A POINT 194 FEET SOUTH OF THE NORTH LINE OF SAID SEMINARY LOT NUMBER 46, THENCE WEST 55 FEET AND TO THE PLACE OF BEGINNING.

ALSO, A PART OF SEMINARY LOT 46 IN THE CITY OF BLOOMINGTON, INDIANA, BOUNDED AND DESCRIBED AS FOLLOWS, TO-WIT: BEGINNING AT A POINT 110 FEET EAST OF THE NORTHWEST CORNER OF SAID SEMINARY LOT, RUNNING THENCE EAST 55 FEET, THENCE SOUTH 194 FEET, THENCE WEST 55 FEET, THENCE NORTH 194 FEET TO THE PLACE OF BEGINNING.

TRACT 9: [INTENTIONALLY NOT INCLUDED]

TRACT 10:

PARCEL I:

ONE HUNDRED FEET OF EVEN WIDTH OFF THE ENTIRE NORTH END OF SEMINARY LOT 10 IN BLOOMINGTON, INDIANA. ALSO, SEMINARY LOT 11 AND SEMINARY LOT 12 IN BLOOMINGTON, INDIANA. ALSO, PART OF SEMINARY LOT 13 AND SEMINARY LOT 14 IN BLOOMINGTON, INDIANA, DESCRIBED AS FOLLOWS: BEGINNING AT THE SOUTHEAST CORNER OF SAID SEMINARY LOT 13, THENCE WEST OVER AND ALONG THE SOUTH LINE OF SAID SEMINARY LOT 13 FOR A DISTANCE OF 158.56 FEET TO A POINT 50.00 FEET EAST OF THE SOUTHWEST CORNER OF SAID SEMINARY LOT 13, THENCE NORTH PARALLEL TO THE WEST LINE OF SAID SEMINARY LOT 13 FOR A DISTANCE OF 100.00 FEET, THENCE EAST PARALLEL TO THE SOUTH LINE OF SAID SEMINARY LOT 13 FOR A DISTANCE OF 118.56 FEET TO A POINT 40.00 FEET WEST OF THE EAST LINE OF SAID SEMINARY LOT 13, THENCE NORTH PARALLEL TO AND 40.00 FEET WEST OF THE EAST LINE OF SAID SEMINARY LOTS 13 AND 14 FOR A DISTANCE OF 108.96 FEET TO THE NORTH LINE OF SAID SEMINARY LOT 14, THENCE EAST OVER AND ALONG THE NORTH LINE OF SAID SEMINARY LOT 14, SAID NORTH LINE BEING THE SOUTH LINE OF WEST SECOND STREET, FOR A DISTANCE OF 40.00 FEET TO THE NORTHEAST CORNER OF SAID SEMINARY LOT 14, THENCE SOUTH OVER AND ALONG THE EAST LINE OF SAID SEMINARY LOTS 13 AND 14 FOR A DISTANCE OF 208.96 FEET TO THE POINT OF BEGINNING. CONTAINING IN SAID SEMINARY LOTS 13 AND 14 0.46 ACRES, MORE OR LESS.

ALSO, PART OF SEMINARY LOT 37 IN BLOOMINGTON, INDIANA, DESCRIBED AS FOLLOWS:

BEGINNING AT A POINT THAT IS 589.50 FEET SOUTH OF THE NORTH LINE AND 409.44 FEET WEST OF THE EAST LINE OF SAID SEMINARY LOT 37, SAID POINT BEING

ON THE EAST LINE OF SOUTH ROGERS STREET, THENCE EAST FOR A DISTANCE OF 108.00 FEET, THENCE SOUTH FOR A DISTANCE OF 70.50 FEET TO THE NORTH LINE OF WEST FIRST STREET, THENCE EAST OVER AND ALONG THE NORTH LINE OF SAID WEST FIRST STREET FOR A DISTANCE OF 142.44 FEET, THENCE NORTH FOR A DISTANCE OF 108.96 FEET, THENCE EAST FOR A DISTANCE OF 159.00 FEET TO THE EAST LINE OF SAID SEMINARY LOT 37, THENCE NORTHERLY OVER AND ALONG THE EAST LINE OF SAID SEMINARY LOT 37 FOR A DISTANCE OF 481.60 FEET TO A POINT THAT IS 132.00 FEET SOUTH OF THE SOUTH LINE OF WEST SECOND STREET, SAID POINT BEING 412.87 FEET EAST OF THE EAST LINE OF SOUTH ROGERS STREET, THENCE WEST FOR A DISTANCE OF 66.00 FEET, THENCE NORTH FOR A DISTANCE OF 132.00 FEET TO THE SOUTH LINE OF WEST SECOND STREET, THENCE WEST OVER AND ALONG SAID SOUTH LINE FOR A DISTANCE OF 66.00 FEET, THENCE SOUTH FOR A DISTANCE OF 132.00 FEET, THENCE WEST FOR A DISTANCE OF 53.00 FEET, THENCE NORTH FOR A DISTANCE 132.00 FEET TO THE SOUTH LINE OF WEST SECOND STREET, THENCE WEST OVER AND ALONG SAID SOUTH LINE FOR A DISTANCE OF 137.87 FEET TO A POINT 90.00 FEET EAST OF THE EAST LINE OF SOUTH ROGERS STREET, THENCE SOUTH FOR A DISTANCE OF 198.00 FEET, THENCE WEST FOR A DISTANCE OF 90.00 FEET TO THE EAST LINE OF SOUTH ROGERS STREET, THENCE SOUTH OVER AND ALONG SAID EAST LINE OF SOUTH ROGERS STREET FOR A DISTANCE OF 391.04 FEET TO THE POINT OF BEGINNING. EXCEPTING A PART OF SEMINARY LOT 37 IN THE CITY OF BLOOMINGTON, MONROE COUNTY, INDIANA, DESCRIBED AS FOLLOWS: BEGINNING AT A POINT THAT IS 589.50 FEET SOUTH OF THE NORTH LINE OF SAID SEMINARY LOT 37 AND 409.44 FEET WEST OF THE EAST LINE OF SAID SEMINARY LOT 37, SAID POINT BEING ON THE EAST LINE OF SOUTH ROGERS STREET, THENCE NORTH OVER AND ALONG THE EAST LINE OF SAID SOUTH ROGERS STREET FOR A DISTANCE OF 206.00 FEET, THENCE EAST FOR A DISTANCE OF 250.44 FEET, THENCE SOUTH FOR A DISTANCE OF 206.00 FEET, THENCE WEST FOR A DISTANCE OF 250.44 FEET TO THE POINT OF BEGINNING. CONTAINING IN SAID SEMINARY LOT 37 AFTER SAID EXCEPTION 3.70 ACRES, MORE OR LESS.

SUBJECT TO A DRIVEWAY EASEMENT DESCRIBED AS FOLLOWS: BEGINNING AT POINT 185.00 FEET WEST OF THE NORTHEAST CORNER OF SAID SEMINARY LOT 37, THENCE SOUTH FOR A DISTANCE OF 76.50 FEET, THENCE WEST FOR DISTANCE OF 6.00 FEET, THENCE NORTH FOR A DISTANCE OF 76.50 FEET, THENCE EAST FOR A DISTANCE OF 6.00 FEET TO THE POINT OF BEGINNING. ALSO, A DRIVEWAY EASEMENT DESCRIBED AS FOLLOWS: BEGINNING AT A POINT 185.00 FEET WEST OF THE NORTHEAST CORNER OF SAID SEMINARY LOT 37, THENCE SOUTH FOR A DISTANCE OF 76.50 FEET, THENCE EAST FOR A DISTANCE OF 2.00 FEET, THENCE NORTH FOR A DISTANCE OF 76.50 FEET, THENCE WEST FOR A DISTANCE OF 2.00 FEET TO THE POINT OF BEGINNING. SUBJECT TO THE FOLLOWING DESCRIBED INGRESS EGRESS / PARKING EASEMENTS: BEGINNING AT A POINT THAT IS 383.50 FEET SOUTH OF THE NORTH LINE OF SAID SEMINARY LOT 37 AND 373.00 FEET WEST OF THE EAST LINE OF SAID SEMINARY LOT 37, THENCE EAST FOR A DISTANCE OF 178.00 FEET, THENCE NORTH FOR A DISTANCE OF 30.00 FEET, THENCE WEST FOR A DISTANCE OF 43.00 FEET, THENCE NORTH FOR A DISTANCE OF 41.00 FEET, THENCE WEST FOR A DISTANCE OF 135.00 FEET, THENCE SOUTH FOR A

DISTANCE OF 71.00 FEET TO THE POINT OF BEGINNING. ALSO, BEGINNING AT A POINT ON THE EAST LINE OF SAID SEMINARY LOT 37, SAID POINT BEING 434.54 FEET SOUTH OF THE NORTHEAST CORNER OF SAID SEMINARY LOT 37, THENCE NORTH OVER AND ALONG THE EAST LINE OF SAID SEMINARY LOT 37 FOR A DISTANCE OF 60.00 FEET; THENCE WEST FOR A DISTANCE OF 159.00 FEET, THENCE SOUTH FOR A DISTANCE OF 60.00 FEET, THENCE EAST FOR A DISTANCE OF 159.00 FEET TO THE POINT OF BEGINNING. ALSO, BEGINNING AT A POINT ON THE SOUTH LINE OF SAID SEMINARY LOT 37, SAID POINT BEING 265.00 FEET WEST OF THE SOUTHEAST CORNER OF SAID SEMINARY LOT 37, THENCE NORTH FOR A DISTANCE OF 28.00 FEET, THENCE WEST FOR A DISTANCE OF 20.00 FEET, THENCE NORTH FOR A DISTANCE OF 42.5 FEET, THENCE EAST FOR A DISTANCE OF 64.00 FEET, THENCE SOUTH FOR A DISTANCE OF 37.50 FEET, THENCE WEST FOR A DISTANCE OF 20.00 FEET, THENCE SOUTH FOR A DISTANCE OF 33.00 FEET TO THE SOUTH LINE OF SAID SEMINARY LOT 37, THENCE WEST OVER AND ALONG THE SOUTH LINE OF SAID SEMINARY LOT 37 FOR A DISTANCE OF 24.00 FEET TO THE POINT OF BEGINNING. ALSO, SUBJECT TO THE FOLLOWING DESCRIBED EASEMENTS: A PART OF SEMINARY LOT 37, BLOOMINGTON, INDIANA, DESCRIBED AS FOLLOWS: A SANITARY SEWER EASEMENT 16.44 FEET WIDE LYING ON THE WEST SIDE OF AND IMMEDIATELY ADJACENT TO THE FOLLOWING DESCRIBED LINE: BEGINNING AT A POINT THAT IS 285.00 FEET WEST OF THE SOUTHEAST CORNER OF SAID SEMINARY LOT 37, SAID POINT BEING ON THE NORTH LINE OF FIRST STREET, THENCE NORTH FOR A DISTANCE OF 70.50 FEET. A PART OF SEMINARY LOT 37, BLOOMINGTON, INDIANA, DESCRIBED AS FOLLOWS: A UTILITY EASEMENT 18.00 FEET WIDE LYING ON THE EAST SIDE OF AND IMMEDIATELY ADJACENT TO THE FOLLOWING DESCRIBED LINE: BEGINNING AT A POINT THAT IS 221.00 FEET WEST OF THE SOUTHEAST CORNER OF SAID SEMINARY LOT 37, SAID POINT BEING ON THE NORTH LINE OF FIRST STREET, THENCE NORTH FOR A DISTANCE OF 70.50 FEET. A PART OF SEMINARY LOT 37, BLOOMINGTON, INDIANA, DESCRIBED AS FOLLOWS: A UTILITY EASEMENT 12.00 FEET WIDE, LYING 6.00 FEET OF EVEN WIDTH ON BOTH SIDES OF THE FOLLOWING DESCRIBED LINE: BEGINNING AT POINT THAT IS 383.50 FEET SOUTH OF THE NORTH LINE OF SAID SEMINARY LOT 37, AND 258.00 FEET WEST OF THE EAST LINE OF SAID SEMINARY LOT 37, THENCE NORTH FOR A DISTANCE OF 177.00 FEET.

ALSO, A PART OF SEMINARY LOT NUMBER 45 IN THE CITY OF BLOOMINGTON, INDIANA, DESCRIBED AS FOLLOWS: BEGINNING AT THE INTERSECTION OF THE SOUTH LINE OF WEST FIRST STREET WITH THE WEST LINE OF SOUTH ROGERS STREET, SAID INTERSECTION BEING 14.16 FEET WEST OF THE NORTHEAST CORNER OF SAID SEMINARY LOT 45, THENCE NORTH 89 DEGREES 46 MINUTES WEST (ASSUMED BEARING) OVER AND ALONG THE SOUTH LINE OF SAID WEST FIRST STREET FOR A DISTANCE OF 640.84 FEET TO THE EAST LINE OF FAIRVIEW STREET, THENCE SOUTH 0 DEGREES 51 MINUTES 07 SECONDS WEST OVER AND ALONG SAID EAST LINE FOR A DISTANCE OF 331.08 FEET TO THE NORTH LINE OF WYLIE STREET, THENCE SOUTH 89 DEGREES 08 MINUTES EAST OVER AND ALONG SAID NORTH LINE FOR A DISTANCE OF 645.83 FEET TO THE WEST LINE OF SOUTH ROGERS STREET, THENCE NORTH OVER AND ALONG SAID WEST LINE FOR DISTANCE OF 338.20 FEET TO THE POINT AT BEGINNING.

CONTAINING 4.94 ACRES, MORE OR LESS.

ALSO, BEGINNING AT POINT THAT IS 333.31 FEET SOUTH AND 337.34 FEET WEST OF THE NORTHEAST CORNER OF SAID SEMINARY LOT 45, SAID POINT BEGINNING BEING THE INTERSECTION POINT OF THE WEST RIGHT OF WAY OF PLATTED ALLEY 10 FEET IN WIDTH WITH THE NORTH RIGHT OF WAY OF WYLIE STREET, THENCE NORTH FOR A DISTANCE OF 160.00 FEET, THENCE NORTH 89 DEGREES 08 MINUTES WEST FOR A DISTANCE OF 92.00 FEET, THENCE SOUTH FOR A DISTANCE OF 160.00 FEET TO THE NORTH RIGHT OF WAY OF WYLIE STREET, THENCE SOUTH 89 DEGREES 08 MINUTES EAST OVER AND ALONG THE NORTH RIGHT OF WAY OF WYLIE STREET FOR A DISTANCE OF 92.00 FEET TO THE PLACE OF BEGINNING. CONTAINING AFTER SAID EXCEPTIONS, 2.60 ACRES, MORE OR LESS. EXCEPTING ALLEYWAYS 10 FEET IN WIDTH WITHIN THE ABOVE DESCRIBED TRACT WHICH HERETOFORE HAVE NOT BEEN VACATED.

LOTS 1, 2, 3, 4, 5, 6, 7, AND 8 IN SAINT CLAIR'S ADDITION TO THE CITY OF BLOOMINGTON, INDIANA. ALSO, A PART OF SEMINARY LOT NUMBER 37 AND A PART OF SEMINARY LOT NUMBER 46 IN THE CITY OF BLOOMINGTON, INDIANA, DESCRIBED AS FOLLOWS: BEGINNING AT A POINT ON THE NORTH LINE OF SEMINARY LOT 46 THAT IS 245 FEET EAST OF THE NORTHWEST CORNER OF THE SAID SEMINARY LOT NUMBER 46, SAID POINT BEING ON THE SOUTH LINE OF WEST SECOND STREET, THENCE EAST, OVER AND ALONG THE NORTH LINE OF SEMINARY LOT NUMBER 46 (SOUTH LINE OF WEST SECOND STREET), FOR A DISTANCE OF 349 FEET, THENCE SOUTH FOR A DISTANCE OF 330 FEET, THENCE EAST FOR A DISTANCE OF 266 FEET, AND TO THE SOUTHEAST CORNER OF LOT NUMBER 7 IN SAINT CLAIR'S ADDITION TO THE CITY OF BLOOMINGTON, SAID LOT CORNER BEING ON THE WEST LINE OF SOUTH ROGERS STREET, THENCE SOUTH OVER AND ALONG THE WEST LINE OF SOUTH ROGERS STREET FOR A DISTANCE OF 330 FEET, AND TO THE SOUTH LINE OF SEMINARY LOT NUMBER 37, SAID POINT BEING THE INTERSECTION OF THE WEST LINE OF SOUTH ROGERS STREET WITH THE NORTH LINE OF WEST FIRST STREET, THENCE WEST OVER AND ALONG THE SOUTH LINE OF SEMINARY LOT NUMBER 37 (NORTH LINE OF WEST FIRST STREET), FOR A DISTANCE OF 238.94 FEET, AND TO THE SOUTHWEST CORNER OF THE SAID SEMINARY LOT NUMBER 37 AND THE SOUTHEAST CORNER OF SEMINARY LOT NUMBER 46, THENCE CONTINUING WEST, OVER AND ALONG THE SOUTH LINE OF SEMINARY LOT NUMBER 46 (NORTH LINE OF WEST FIRST STREET), FOR A DISTANCE OF 456.06 FEET, THENCE NORTH FOR A DISTANCE OF 490 FEET, THENCE EAST FOR A DISTANCE OF 80 FEET, THENCE NORTH FOR A DISTANCE OF 149.90 FEET, THENCE WEST FOR A DISTANCE OF 2.47 FEET, THENCE NORTH FOR A DISTANCE OF 3.06 FEET TO THE POINT OF CURVATURE OF A CURVE TO THE LEFT HAVING A RADIUS OF 12.60 FEET, SAID POINT OF CURVATURE BEING 12.60 FEET EAST OF THE RADIUS POINT OF SAID CURVE, THENCE NORTHWESTERLY OVER AND ALONG SAID CURVE FOR A DISTANCE OF 15.70 FEET TO A POINT ON SAID CURVE THAT STANDS 12.60 FEET NORTH 18 DEGREES 36 MINUTES 25 SECONDS EAST OF THE RADIUS POINT OF SAID CURVE, THENCE NORTH 68 DEGREES 56 MINUTES 53 SECONDS WEST, NON-TANGENT TO THE LAST DESCRIBED CURVE, FOR A DISTANCE OF 14.20 FEET TO THE NORTH LINE OF SAID SEMINARY LOT 46,

THENCE EAST OVER AND ALONG SAID NORTH LINE FOR A DISTANCE OF 24.30 FEET TO THE POINT OF BEGINNING. CONTAINING 8.20 ACRES, MORE OR LESS.

PARCEL II:

A PART OF SEMINARY LOT 45 IN BLOOMINGTON, MONROE COUNTY, INDIANA DESCRIBED AS FOLLOWS: BEGINNING AT A POINT THAT IS 14.16 FEET WEST OF THE NORTHEAST CORNER OF SAID SEMINARY LOT 45, SAID BEGINNING POINT BEING THE INTERSECTION POINT OF THE WEST RIGHT OF WAY OF SOUTH ROGERS STREET WITH THE SOUTH RIGHT OF WAY OF FIRST STREET, THENCE NORTH 89 DEGREES 46 MINUTES WEST (ASSUMED BEARING) OVER AND ALONG THE SOUTH RIGHT OF WAY OF WEST FIRST STREET FOR A DISTANCE OF 220.96 FEET TO A POINT THAT IS 419.00 FEET EAST OF THE NORTHWEST CORNER OF SAID SEMINARY LOT 45, THENCE SOUTH FOR A DISTANCE OF 198.03 FEET, THENCE SOUTH 89 DEGREES 47 MINUTES 42 SECONDS WEST FOR A DISTANCE OF 198.03 FEET, THENCE SOUTH 89 DEGREES 47 MINUTES 42 SECONDS WEST FOR A DISTANCE OF 92.21 FEET TO THE EAST RIGHT OF WAY ON A PLATTED ALLEY 10 FEET IN WIDTH, THENCE SOUTH OVER AND ALONG THE EAST RIGHT OF WAY OF SAID PLATTED ALLEY FOR A DISTANCE OF 136.00 FEET TO THE NORTH RIGHT OF WAY OF WYLIE STREET, THENCE SOUTH 89 DEGREES 08 MINUTES EAST OVER AND ALONG THE NORTH RIGHT OF WAY OF WYLIE STREET FOR A DISTANCE OF 313.21 FEET TO THE WEST RIGHT OF WAY OF SOUTH ROGERS STREET, THENCE NORTH OVER AND ALONG WEST RIGHT OF WAY OF SOUTH ROGERS STREET FOR A DISTANCE OF 338.20 FEET TO THE PLACE OF BEGINNING.

ALSO, BEGINNING AT A POINT THAT IS 333.31 FEET SOUTH AND 337.34 FEET WEST OF THE NORTHEAST CORNER OF SAID SEMINARY LOT 45, SAID POINT OF BEGINNING BEING THE INTERSECTION POINT OF THE WEST RIGHT OF WAY OF A PLATTED ALLEY 10 FEET IN WIDTH WITH THE NORTH RIGHT OF WAY OF WYLIE STREET, THENCE NORTH FOR A DISTANCE OF 160.00 FEET, THENCE NORTH 89 DEGREES 08 MINUTES WEST FOR A DISTANCE OF 92.00 FEET, THENCE SOUTH FOR A DISTANCE OF 160.00 FEET TO THE NORTH RIGHT OF WAY OF WYLIE STREET, THENCE SOUTH 89 DEGREES 08 MINUTES EAST OVER AND ALONG THE NORTH RIGHT OF WAY OF WYLIE STREET FOR A DISTANCE OF 92.00 FEET TO THE PLACE OF BEGINNING. EXCEPTING ALLEYWAYS 10 FEET IN WIDTH WITHIN THE ABOVE DESCRIBED TRACT, WHICH HERETOFORE HAVE NOT BEEN VACATED.

[Legal description to be confirmed during the Due Diligence Period.]

EXHIBIT B

The New Hospital Property



EXHIBIT C

Parcel Identification

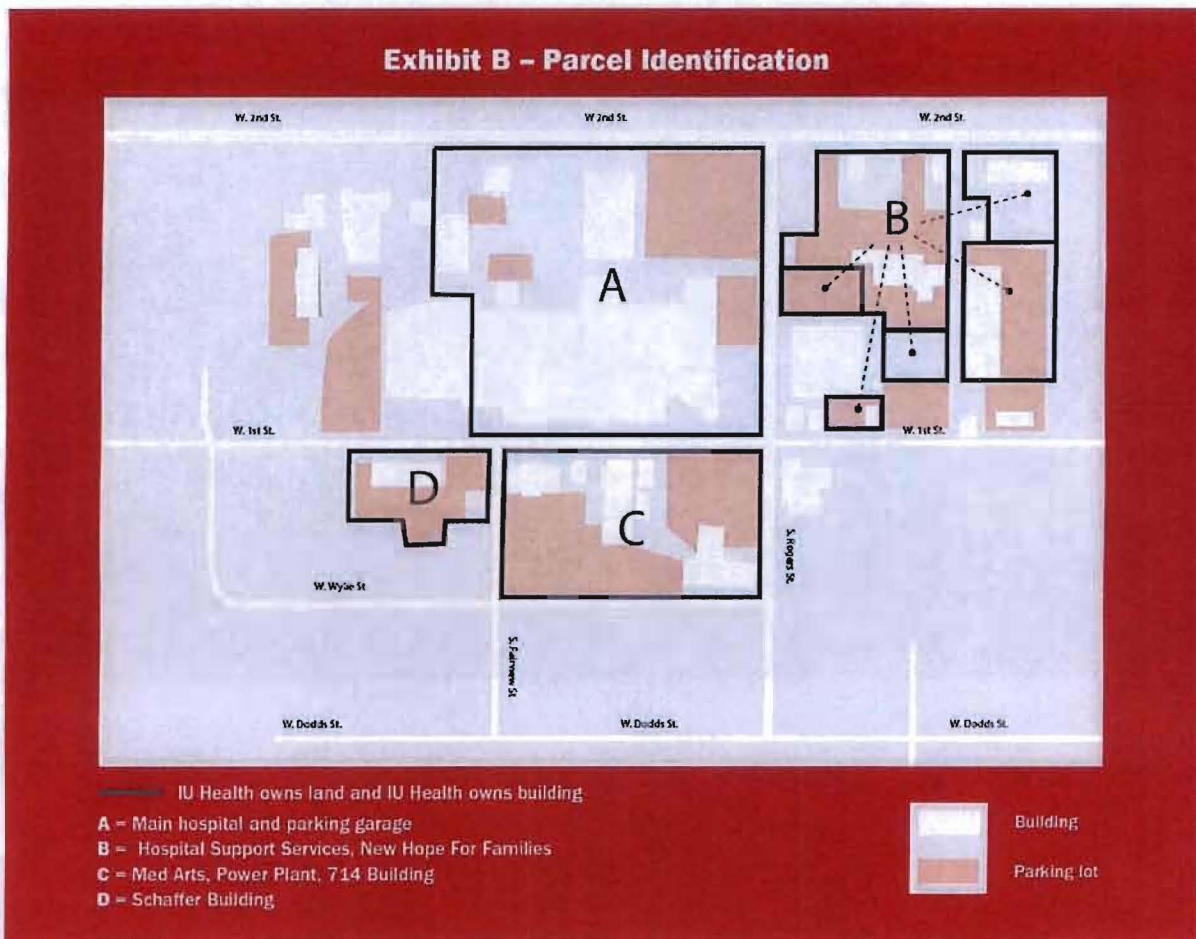

EXHIBIT D

Parking Garage – Access Drives to be Maintained (to be identified in yellow)

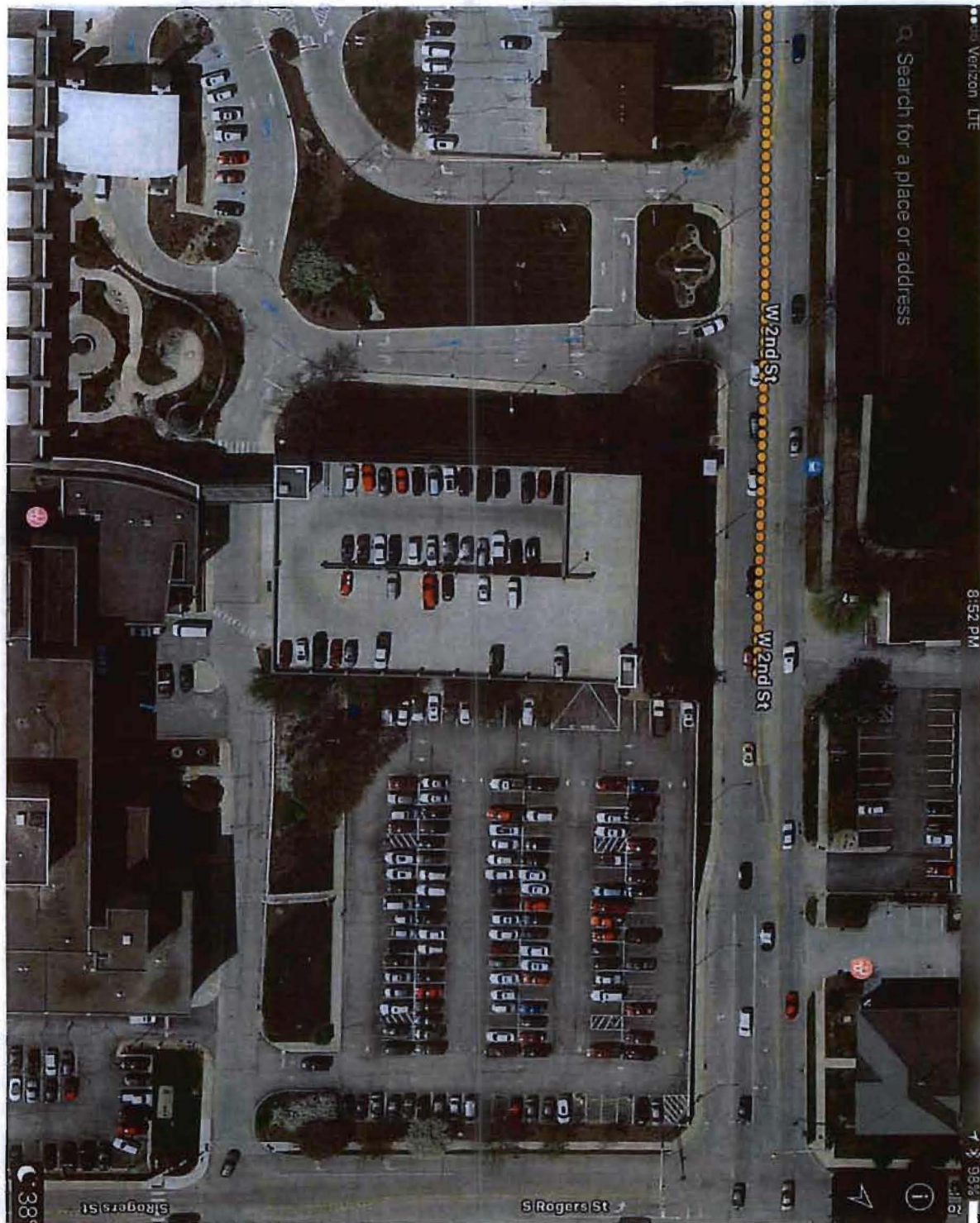

EXHIBIT E

Insert Depiction of the Kohr Administration Building



City of Bloomington
Redevelopment Commission
Amended Project Review & Approval Form

Please Note:

- Approval of the project by the Redevelopment Commission through this Project Review & Approval Form does not represent an authorization to begin work or expend funds.
- Authorization of work and the commitment of funds shall be done when the Redevelopment Commission reviews and approves: (1) a Purchase Order or Contract prepared after complying with the appropriate procurement process for the type of item, service or construction being sought and (2) the estimated costs associated with the Purchase Order or Contract.
- No payment of funds shall be made without a duly authorized and approved Purchase Order or Contract. All claims for payment against a duly authorized Purchase Order or Contract shall be submitted to the Redevelopment Commission for their review and approval along with any required departmental inspections, reviews and approvals prior to the payment of any funds.

To Be Completed by Requesting Party:

Project Name: Regional Economic Acceleration and Development Initiative (READI) for Hopewell Street Construction

Project Manager(s): John Zody

Project Description:Background

In May of 2021, the State of Indiana launched the Regional Economic Acceleration and Development Initiative (READI), which utilized federal American Rescue Plan Act (ARPA) funds, to foster programs, initiatives, and projects critical to attracting and retaining talent for the workforce. Bloomington was part of an Uplands regional grant award through Regional Opportunity Initiatives.

Project overview

The City of Bloomington applied for a READI grant to fund the design and construction of a major section of Jackson St. in the Hopewell development (former IU Health Hospital). The funded portion of Jackson Street would run from 1st Street to the proposed University Street.

The design and construction of this portion of Jackson Street is critical for the redevelopment of the 1947 Kohr Administration Building. This section of Jackson St. will be on the west end of the Kohr building parcel. The targeted redevelopment of the Kohr Building includes 40 units of affordable housing serving residents who are 60% and below Area Median Income (AMI). In addition, the completion of Jackson St. will provide an additional artery of infrastructure on the site that will serve up to 400 units of new housing (including the 40 new units in the Kohr Building), connecting to the main site corridor (University St.) near the 427-space parking garage that will also remain.

READI funds will be for the design and construction of the project, so a general developer and contractor have not yet been named. Design and construction bidding will be done by the City of Bloomington Redevelopment Commission and the City’s Engineering Department through the City of Bloomington's procurement process.

Project Timeline: **Start Date:** **April 2023**
 End Date: **December 2024**

Financial Information:

Estimated full cost of project:	\$7,039,050.00
Sources of funds:	READI: \$1,999,920.00 \$1,800,000.00 Consolidated TIF: \$5,039,130 \$5,239,050 (match in Hopewell)

Project Phases: This breakdown should mirror the contract(s) expected to be issued for this project. Each phase should include a description of the work to be performed, the cost, and the timeline for the contract.

Step	Description	Estimated Cost	Timeline
1	Design	\$550,000	2023
2	Construction Inspection	\$121,000	2023-24
3	Construction	\$1,022,420	2023-24
4	Other Engineering	\$306,500	
4	Other Related Hopewell Construction for Match	\$5,039,130	2024

TIF District: Consolidated TIF (Expanded Adams Crossing)

Resolution History: 23-04 Project Review and Approval Form (Match)
 23-29 Approval of READI Grant Agreement

To Be Completed by Redevelopment Commission Staff:

Approved on _____

By Resolution _____ by a vote of _____