

Board of Public Works Meeting

May 06, 2024



The City will offer virtual options, including CATS public access television (live and tape-delayed) and

Public comments and questions will be encouraged via Zoom or bloomington.in.gov rather than in person

The City is committed to providing equal access to information. However, despite our efforts, at times, portions of our board and commission packets are not accessible for some individuals. If you encounter difficulties accessing material in this packet, please contact April Rosenberger, Public Works Departmental Accessibility contact at april.rosenberger@bloomington.in.gov or 812.349.3411 and provide your name, contact information, and a link to or description of the document or web page you are having problems with.

AGENDA
BOARD OF PUBLIC WORKS
May 06, 2024

A Regular Meeting of the Board of Public Work will be held **Monday, May 06, 2024 at 5:30 p.m.** in the Council Chambers (RM# 115) of City Hall at the Showers Building, 401 N. Morton Street, Bloomington, Indiana and via Zoom by using the following link

<https://bloomington.zoom.us/j/88937320572?pwd=Avk2lVZAqXCbDbJ6sOYp3cNQhGnkam.1>

Meeting ID: 889 3732 0572 Passcode: 010218

- I. MESSAGES FROM BOARD MEMBERS**
- II. PETITIONS AND REMONSTRANCES**
- III. CONSENT AGENDA**
 - 1. Sidewalk Closure And Metered Parking Reservation Request from Omega Properties at 626 N. College Ave
 - 2. Approval of Payroll
- IV. NEW BUSINESS**
 - 1. Change Orders #1 & #2 for the 1st Street Reconstruction Project
 - 2. Request to Reissue Closure Permits from AEG for S. Maxwell St. and N. Williams St.
 - 3. Lane and Sidewalk Closure Request from AEG on E. Moody Drive
 - 4. Sidewalk and Lane Closure and Metered Parking Reservation Request from Strauser Construcion for 430 E. Kirkwood
 - 5. Lane and Sidewalk Closure Request from Kokosing Industrial on E. Morningside Drive
 - 6. Agreement with Windcave for Payment Processing at City Garages
 - 7. 2024 Service Agreement with H&K Maintenance, LLC
- V. STAFF REPORTS & OTHER BUSINESS**
- VI. APPROVAL OF CLAIMS**
- VII. ADJOURNMENT**

The City is committed to providing equal access to information. However, despite our efforts, at times, portions of our board and commission packets are not accessible for some individuals. If you encounter difficulties accessing material in this packet, please contact April Rosenberger, Public Works Departmental Accessibility contact at april.rosenberger@bloomington.in.gov or 812.349.3411 and provide your name, contact information, and a link to or description of the document or web page you are having problems with.

The City offers virtual options, including **CATS** public access television (live and tape- delayed). Comments and questions will be encouraged via Zoom or bloomington.in.gov rather than in person.

Auxiliary aids for people with disabilities are available upon request with adequate notice. Please call 812.349.3411 or email public.works@bloomington.in.gov



Board of Public Works Staff Report

Project/Event: Request from Omega Properties for sidewalk closure and metered parking reservation

Staff Representative: Kyle Baugh

Petitioner/Representative: Justin Sullivan

Date: May 6th, 2024

Report:

Omega Properties is requesting a one-week sidewalk closure on the east side of their property located at 626 N College Ave. This request is part of their renovation project at the mentioned location and will be used to remove and reinstall the sidewalk at the property. The exact dates for the sidewalk closure will be determined within the period from May 7th, 2024, to August 14th, 2024. Additionally, they are requesting the reservation of four metered parking stalls adjacent to the property for the same period.

Omega Properties has provided maintenance of traffic plans for all work associated with the renovation.

Staff has reviewed the request from Omega Properties and recommends granting permission for the temporary sidewalk closure and metered parking reservation at 626 N College Ave.

OMEGA PROPERTIES

115 E. 6TH ST. SUITE 1 – BLOOMINGTON, IN 47408
O: 812.333.0995 – F: 812.333.0996 – E: OMEGAPROPERTIES@GMAIL.COM

4/18/2024

Board of Public Works
City of Bloomington
401 N Morton St.
Bloomington, In 47404

Re: 626 N College Ave Parking

Dear Board Members:

Omega Properties is currently completing renovations and additions at 626 N College Ave. In order to facilitate this project, Omega Properties is respectfully requesting the metered parking spots in front of 626 to be reserved (COLN 600-A, COLN 600-B, COLN 602-A, COLN 602-B) and added to the current ROW permit (ROW2024-03-0738) for material staging, construction parking and off-loading purposes from May 5th, 2024 through August 14, 2024.

Thanks,
Savannah Harden



Property/Office Manager
Omega Properties

Figure 6H-28. Sidewalk Detour or Diversion (TA-28)

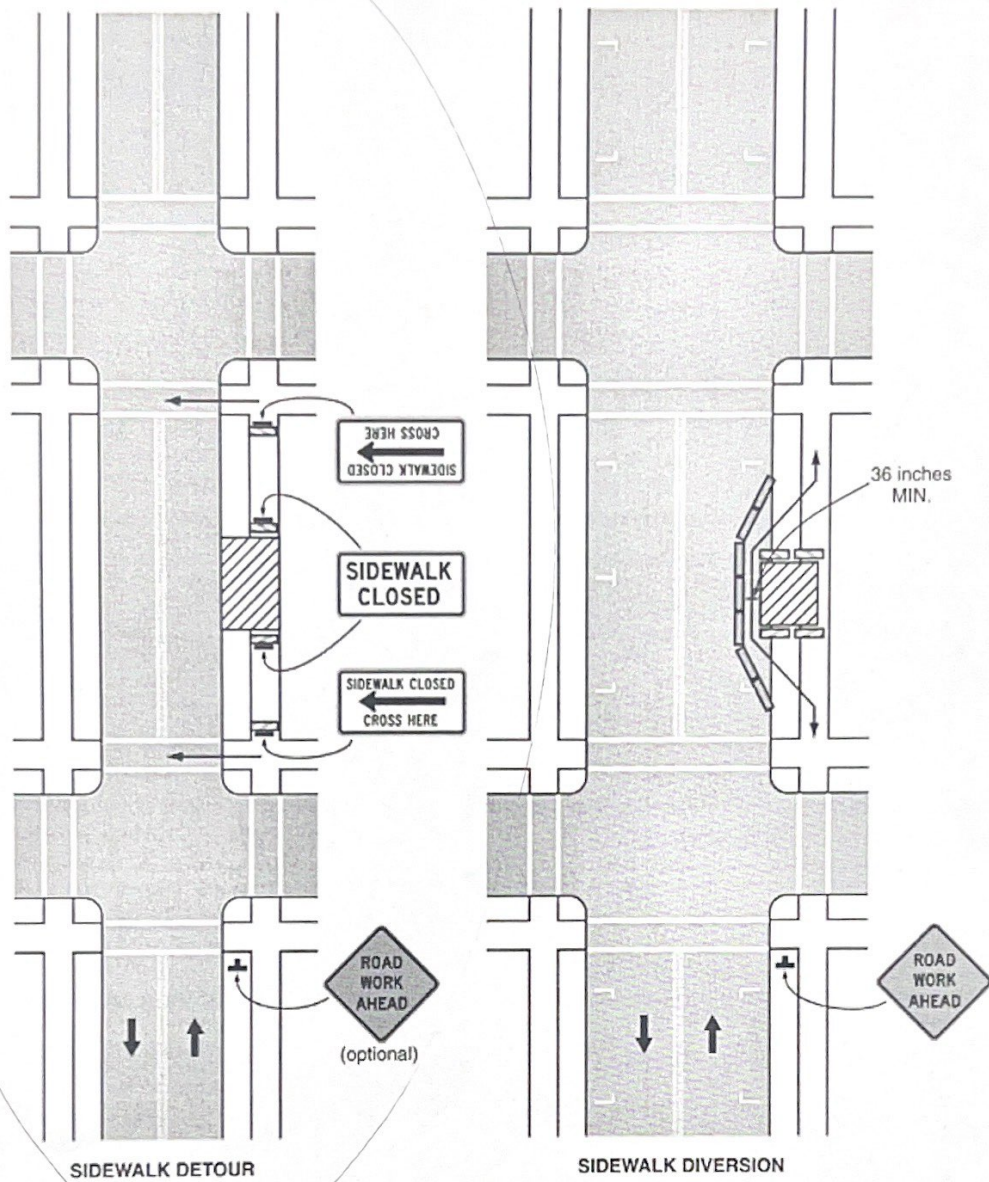

Typical Application 28

Note: See Tables 6H-2 and 6H-3 for the meaning of the symbols and/or letter codes used in this figure.

Figure 6H-28. Sidewalk Detour or Diversion (TA-28)

This figure illustrates two examples of a sidewalk detour or diversion. A legend under the figure states that this is Typical Application 28. A note states "See Tables 6H-2 and 6H-3 for the meaning of the symbols and/or letter codes used in this figure."

This figure shows two examples of a vertical roadway with one lane of traffic in each direction intersecting two horizontal roadways. Black arrows on the vertical roadway indicate that traffic is one lane in each direction. The opposing lanes on the vertical roadway are shown separated by a solid double yellow line. Vertical and horizontal sidewalks identified by thick solid white lines bordered by

626 N. COLLEGE BUILDING ADDITION

626 N. COLLEGE AVE. AVENUE

BLOOMINGTON, INDIANA

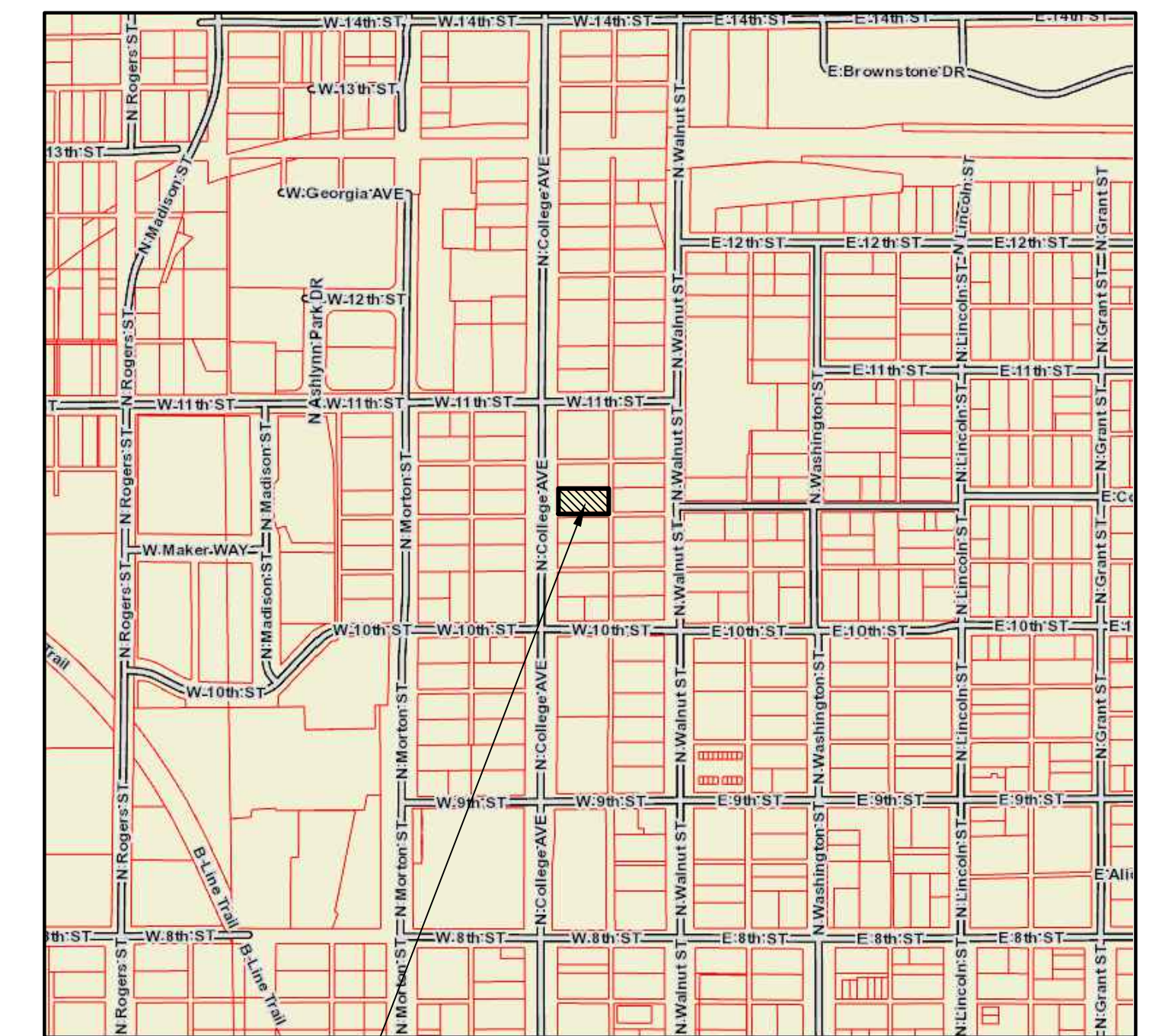
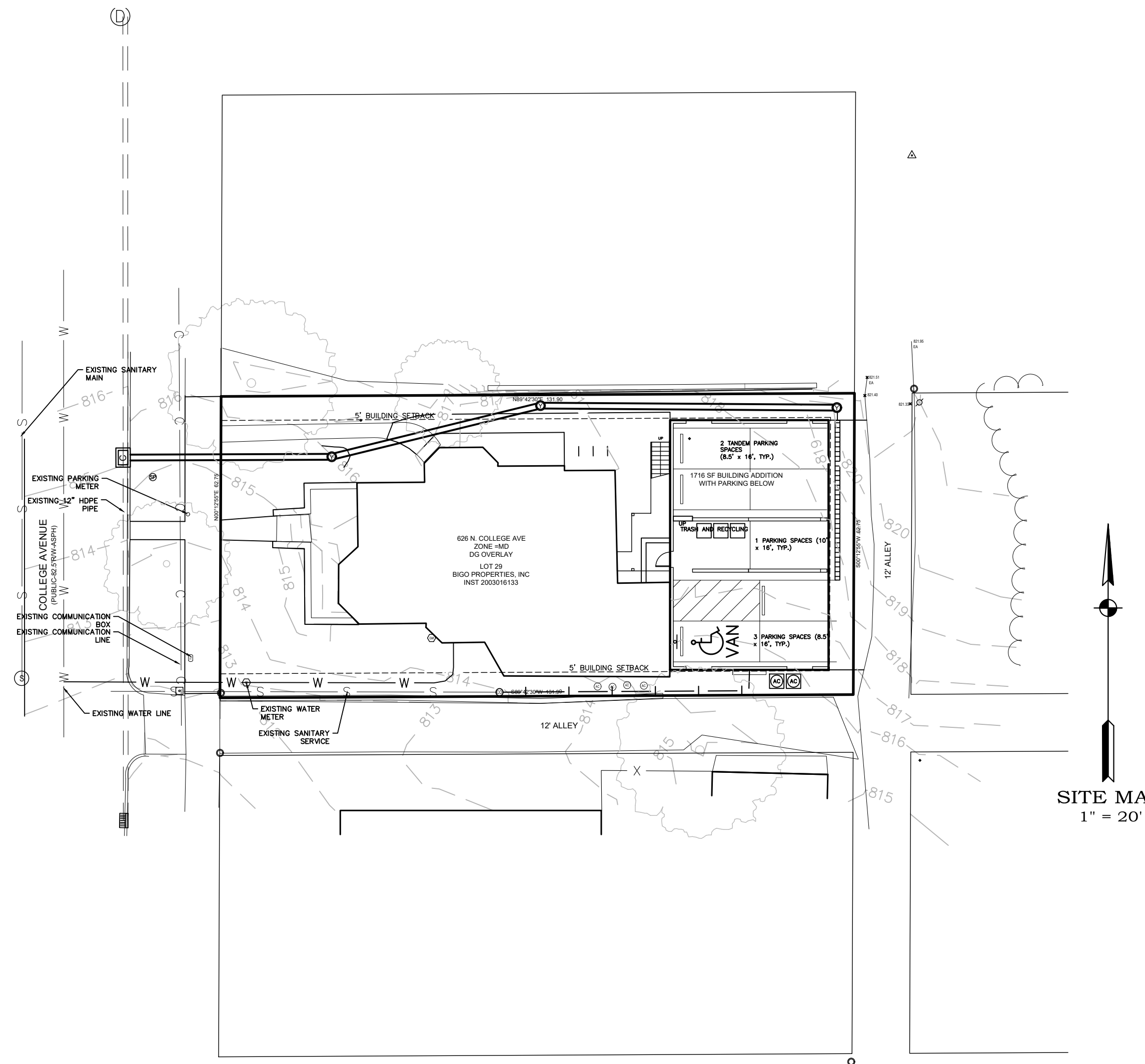

PROJECT LOCATION LOCATION MAP
N.T.S.

SITE MAP
1" = 20'



SHEET NO.	REVISIONS	BY	DATE
2, 3, 4, 5, 6, 7	CBU REVISIONS	DK	4/3/23
7	CBU REVISIONS	DK	5/30/23
2, 3, 4, 5, 6, 7	PLANNING AND CBU REVISIONS	DK	8/23/23
2, 3, 4, 5, 6, 7	PLANNING AND CBU REVISIONS	DK	10/11/23

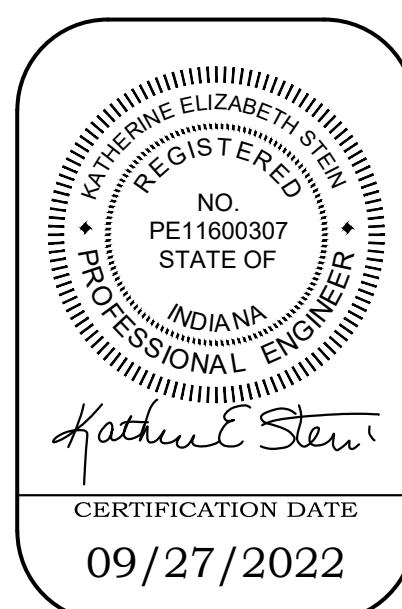

NOTE : WATER, AND SANITARY SEWER ITEMS SHALL BE IN ACCORDANCE WITH THE LATEST ISSUE OF THE CITY OF BLOOMINGTON UTILITIES CONSTRUCTION SPECIFICATIONS. ALL OTHER WORK SHALL BE IN ACCORDANCE WITH THE 2021 SMITH DESIGN GROUP, INCORPORATED STANDARD SPECIFICATIONS.



SMITH DESIGN GROUP
CIVIL ENGINEERING - LAND SURVEYING
1467 W Arlington Road, Bloomington, IN 47404
(812) 336-6536 - smithdgroup.com

JOB NUMBER: 6396

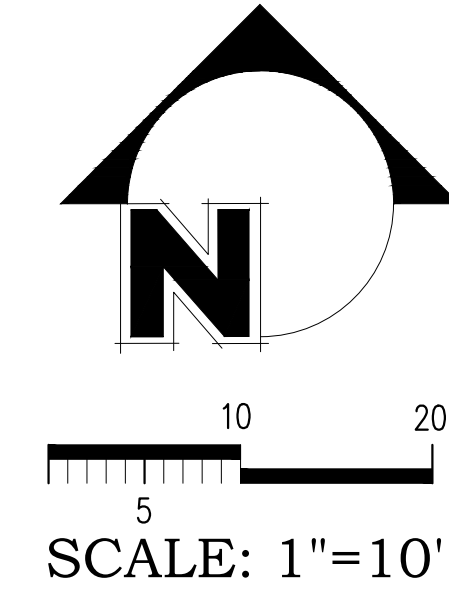
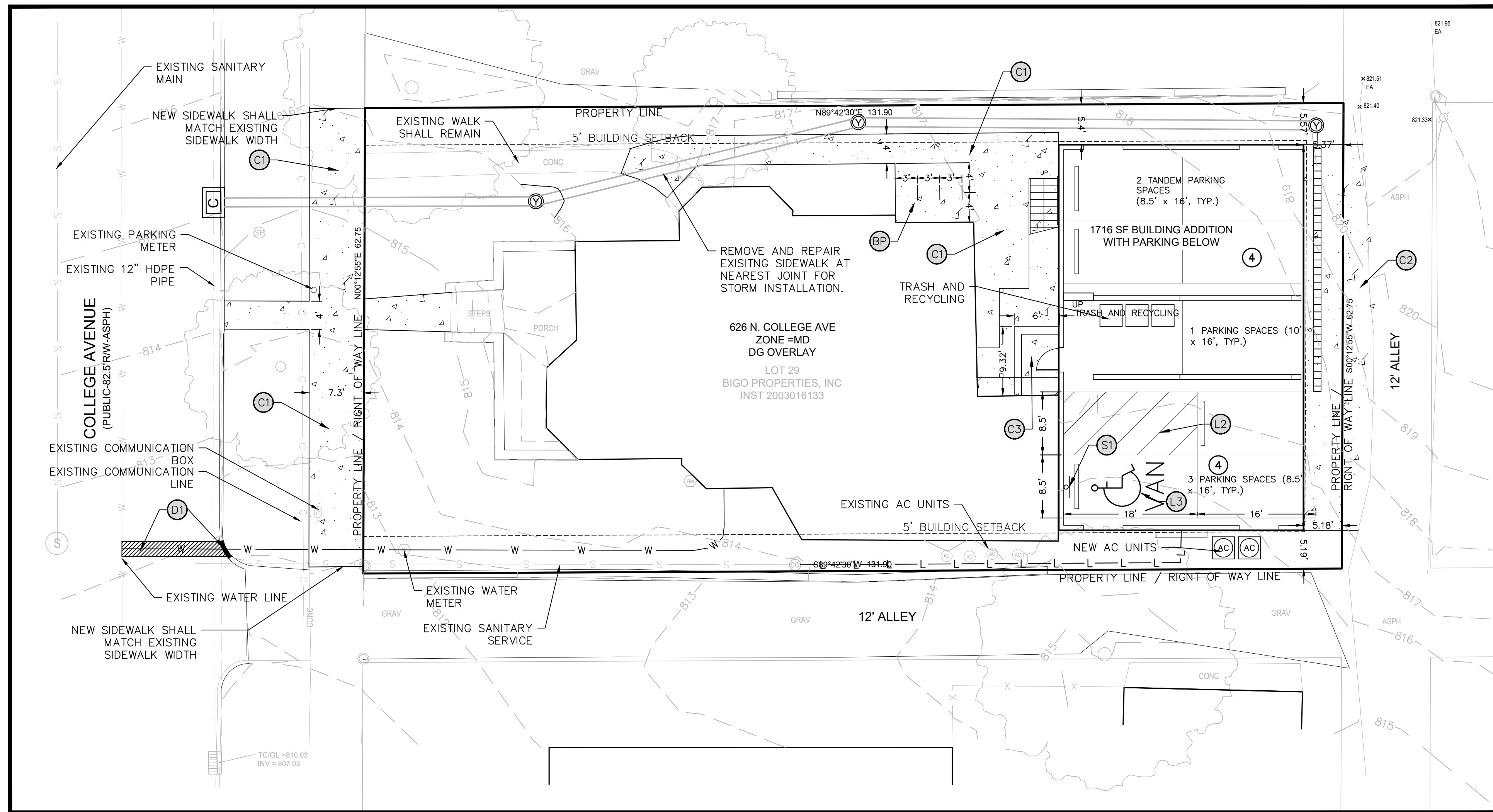

LEGEND

- | | | | |
|------------------------|-------------------------|----------------------------------|-------|
| ○ UTILITY POLE | ○ YARD INLET | — OVERHEAD WIRES | — OHW |
| ⊙ LIGHT POLE | ⊙ WATER VALVE | — SANITARY SEWER | — S |
| — GUY WIRE | ⊙ WATER MANHOLE | — UNDERGROUND GAS LINE | — G |
| ⊙ ELECTRIC METER | ⊙ WATER METER | — UNDERGROUND ELECTRIC LINE | — E |
| ⊙ ELECTRIC MANHOLE | ⊙ FIRE HYDRANT | — UNDERGROUND COMMUNICATION LINE | — C |
| ⊙ ELECTRIC VAULT | ⊙ AIR CONDITIONER | — WATER LINE | — W |
| ⊙ ELECTRIC HANDHOLE | ⊙ GAS METER | — STORM SEWER | — ST |
| ⊙ ELECTRIC TRANSFORMER | ⊙ GAS VALVE | — FENCE | — X X |
| ⊙ SANITARY MANHOLE | ⊙ COMMUNICATION MANHOLE | | |
| ⊙ CLEAN OUT | ⊙ COMMUNICATION VAULT | | |
| ⊙ STORM MANHOLE | ⊙ FIBER OPTIC MANHOLE | | |
| ⊙ CURB INLET | ⊙ FIBER OPTIC VAULT | | |
| ⊙ INLET ROUND | ⊙ CONCRETE BOLLARD | | |
| ⊙ INLET SQUARE | ⊙ SIGN | | |
| ⊙ AIR CONDITIONER | ⊙ PARKING METER | | |
| ⊙ BOLLARD | ⊙ ACCESSIBLE PARKING | | |
| | ○ TELEPHONE RISER | | |
| | ○ FIBER OPTIC RISER | | |

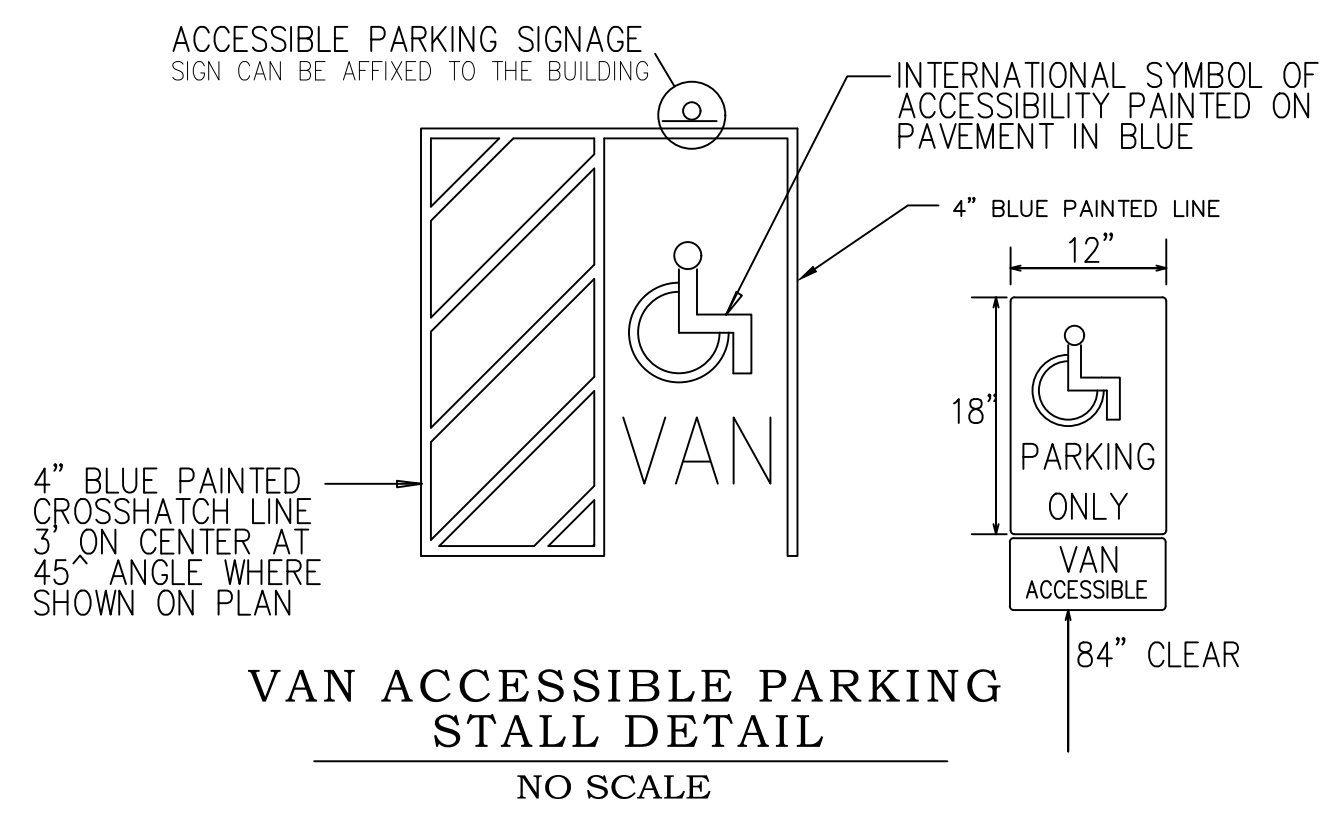

SITE MATERIALS

- ⊙ CONCRETE SIDEWALK (SEE DETAIL ON DETAILS SHEET)
 4" 3500 PSI CONCRETE
 4" COMPACTED AGGREGATE BASE #53
- ⊙ CONCRETE PAVEMENT
 6" THICK CONCRETE, 4000 PSI
 8" INDOT #53 COMPACTED AGGREGATE BASE
- ⊙ CONCRETE STOOP WITH 2 STEPS
 DOWN TO EXISTING BUILDING DOOR.
- ⊙ BIKE PARKING - 3 RACKS REQUIRED FOR 6 TOTAL
 BIKE SPACES. SEE DETAIL ON DETAIL SHEET
- ⊙ LINE, PAINT, BLUE, 6" CROSS HATCH
- ⊙ SYMBOL, PAINT, BLUE, INTERNATIONAL
 SYMBOL OF ACCESSIBILITY AND LETTERS
 "VAN" WHERE INDICATED ON THESE PLANS
 ADA SIGN PER DETAIL
- ⊙ SAWCUT REMOVE AND REPLACE ASPHALT PAVEMENT
 AND CURB FOR WATER LINE INSTALLATION. SEE PATCH
 DETAIL ON SHEET 6

SITE PLAN NOTES

1. SIDEWALK RAMPS SHALL BE IN ACCORDANCE WITH THE LATEST ADA, INDOT AND CITY OF BLOOMINGTON REQUIREMENTS. CONTRACTOR SHALL COORDINATE WORK WITH CITY ENGINEERING PRIOR TO COMMENCEMENT.
2. AT SIDEWALK RAMPS THE CONTRACTOR SHALL REMOVE CONCRETE SIDEWALK PANELS TO NEAREST CONSTRUCTION JOINT TO MEET ADA, INDOT AND CITY OF BLOOMINGTON REQUIREMENTS.
3. PAVEMENT MARKINGS IF SHOWN SHALL BE APPLIED IN ACCORDANCE WITH SECTION 808 & 912.14 OF THE CURRENT INDOT STANDARD SPECIFICATIONS AND AS SHOWN ON THE PLANS.
4. CONTRACTOR IS RESPONSIBLE FOR OBTAINING A CITY RIGHT OF WAY USE PERMIT IF WORK WITHIN THE PUBLIC R/W IS NECESSARY FOR THE PROJECT COMPLETION.
5. BUILDING AND SITE LIGHTING SHALL MEET CITY UDO LIGHTING STANDARDS IN SECTION 20.04.090.

GENERAL NOTES

1. SEE SMITH DESIGN GROUP 2021 STANDARD SPECIFICATIONS FOR CONSTRUCTION REQUIREMENTS.
2. CONTRACTOR SHALL CONTACT WITH CITY PLANNING AND TRANSPORTATION, ENGINEERING AND CITY OF BLOOMINGTON UTILITIES FOR PRE CONSTRUCTION MEETING TO COORDINATE CONSTRUCTION SCHEDULES AND MAINTENANCE OF TRAFFIC.
3. LOCATION OF EXISTING UTILITIES ARE TO BE VERIFIED IN THE FIELD BY THE CONTRACTOR. PLEASE NOTIFY ENGINEER IF FIELD ADJUSTMENTS ARE NECESSARY.
4. TOP OF CASTING ELEVATIONS ARE GIVEN IN THE FOLLOWING LOCATIONS:
 MANHOLES: RIM ELEVATION
 INLETS: GUTTER ELEVATION

ZONE: MD WITH DG OVERLAY
 SITE: 8276.5 SF
 EXISTING STRUCTURE (4 UNIT 7 BEDROOM); 2661 SF
 PROPOSED BUILDING ADDITION (2 UNIT 4 BEDROOM); 1720 SF
 PAVEMENT: 1159 SF
 TOTAL IMPERVIOUS: 5540 SF (67%)
 TOTAL PERVIOUS: 2736.5 SF (33%)

MINIMUM PARKING REQUIRED MD DISTRICT	PARKING REQUIRED
BEDROOMS	1 SPACE PER DU
1 BEDROOM UNIT	1.5 SPACES PER DU
2 BEDROOM	1.5 SPACES PER DU
3 BEDROOMS	2 SPACES PER DU

THIS PROJECT HAS 6 DWELLING UNITS WITH 11 BEDROOMS
 EX. DU 1 - 3 BR UNIT 2 SPACES REQUIRED
 EX. DU 2 - 1 BR UNIT 1 SPACES REQUIRED
 EX. DU 3 - 2 BR UNIT 1.5 SPACES REQUIRED
 EX. DU 4 - 1 BR UNIT 1 SPACES REQUIRED
 PR. DU 5 - 2 BR UNIT 1.5 SPACES REQUIRED
 PR. DU 6 - 2 BR UNIT 1.5 SPACES REQUIRED

TOTAL MINIMUM PARKING REQUIRED=8 SPACES
 15% PARKING REDUCTION FOR PROXIMITY WITHIN BUS STOP
 MINIMUM PARKING REQUIRED 7.2 SPACES
 TOTAL PARKING PROVIDED=8 SPACES
 MAXIMUM PARKING 1.25 SPACES PER BR = 13.75 SPACES

REVISIONS	BY	DATE
CBU REVISIONS	DK	4/3/23
CBU REVISIONS	DK	5/04/23
PLANNING AND CBU REVISIONS	DK	8/23/23
PLANNING AND CBU REVISIONS	DK	10/11/23

DISBURSED	DATE
DK	
WDW	
CHICKED	

JOB NUMBER
6396
 SHEET
2 OF 7

DATE
 10/11/2023

SITE PLAN

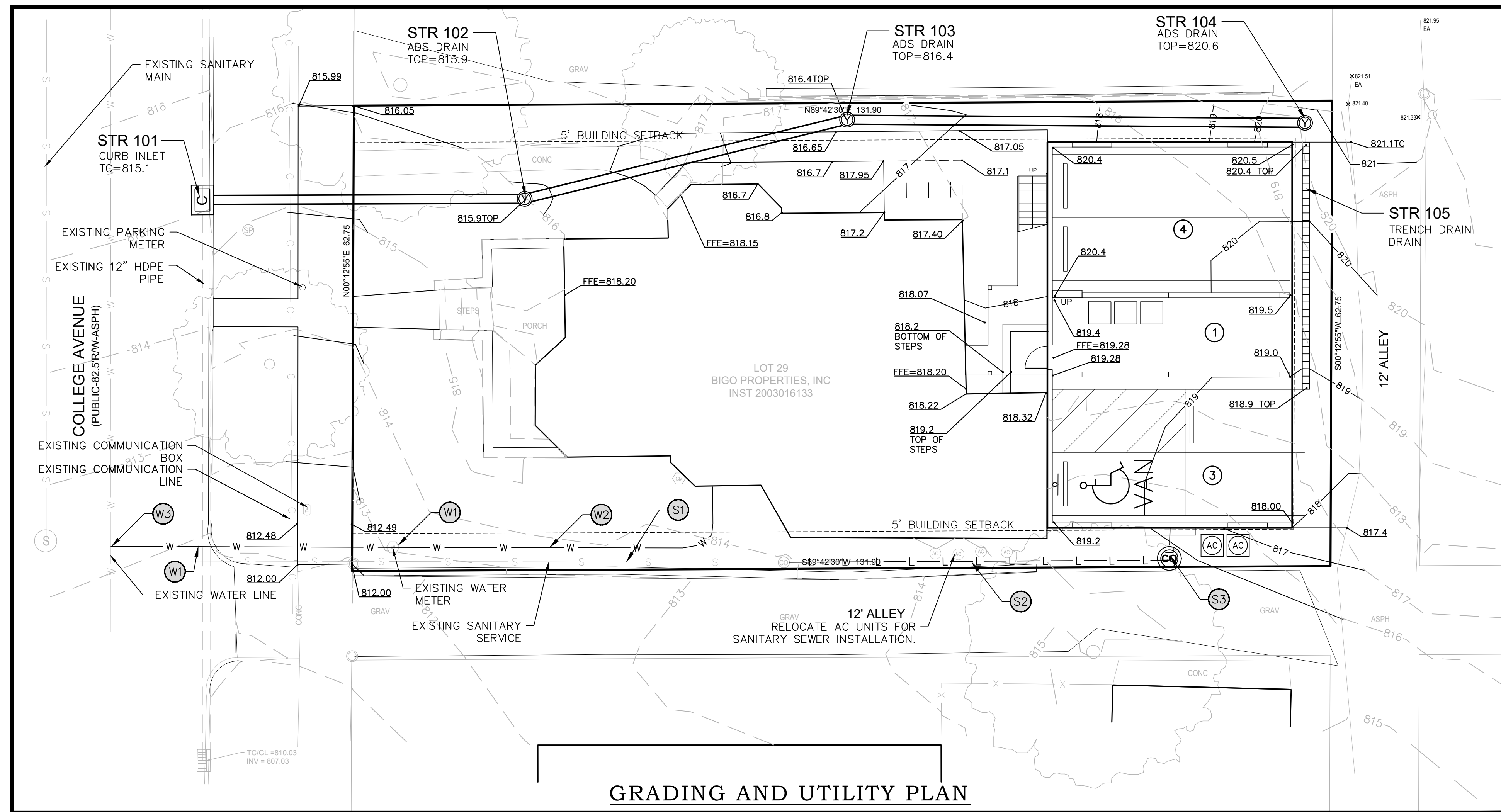

GRADING AND UTILITY PLAN

- SANITARY SEWER NOTES (S)**
- EXISTING SANITARY SEWER SERVICE. CONTRACTOR SHALL VERIFY CONDITION AND SIZE WITH CITY OF BLOOMINGTON UTILITIES INSPECTOR PRESENT PRIOR TO CONNECTION. THE EXISTING LINE MAY NEED TO BE REMOVED AND REPLACED BASED ON SIZE AND CONDITION.
 - NEW 6" SANITARY LATERAL AT 1% MINIMUM SLOPE. VERIFY CONDITION AND DEPTH OF EXISTING SANITARY SERVICE PRIOR TO INSTALLATION OF NEW SANITARY LATERAL.
 - NEW SANITARY CLEAN OUT. SEE DETAIL ON SHEET 6.

- WATER NOTES**
- EXISTING WATER SERVICE LOCATION. CONTRACTOR SHALL COORDINATE INSTALLATION OF NEW 1 1/2" WATER METER WITH CBU. CONTRACTOR SHALL INSTALL NEW 2" WATER SERVICE LINE FROM WATER MAIN TO THE NEW METER TO THE BUILDING. FIRE SYSTEM DESIGNER SHALL CONTACT NANCY AXSOM AT CBU WITH PEAK DEMANDS FOR FIRE SYSTEM PRIOR TO INSTALLATION.
 - NEW 2" WATER LINE PER CBU SPECS.
 - NEW 2" TAP ON EXISTING WATER MAIN.

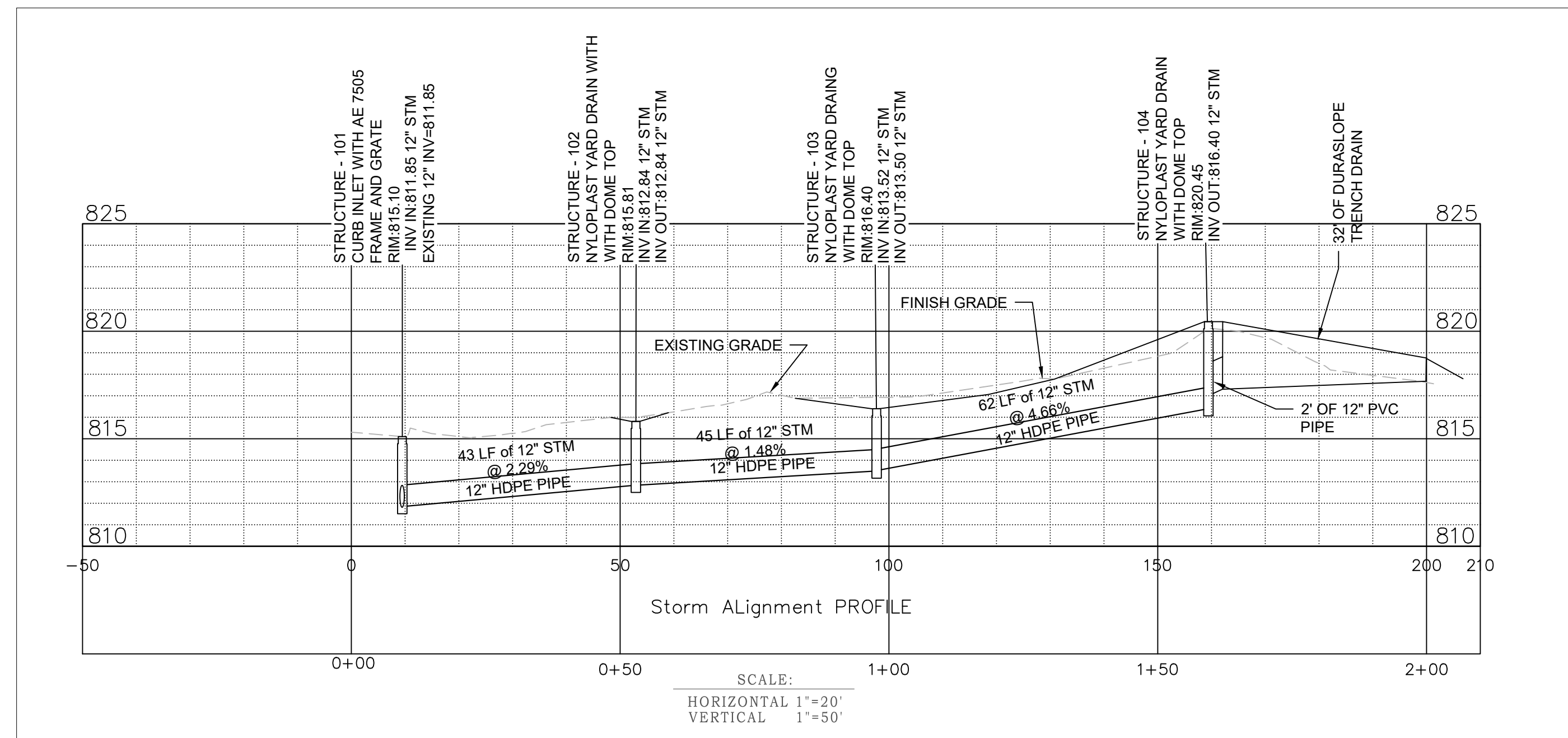

SCALE:
HORIZONTAL 1"=20'
VERTICAL 1"=50'

UTILITY CONTACTS

AT&T (Phone)
Brent McCabe - (812) 334-4521
4517 E. Indiana Bell Ct.
P.O. Box 56
Bloomington, Indiana 47408
bml792@att.com

COMCAST (Cable)
Scott Cripe (812) 322-9612
2450 S. Henderson St.
Bloomington, IN 47401
scott_cripe@cable.comcast.com

UDW REMC
812-384-4446
1666 West State Road 54
Bloomfield, IN 47424

VECTREN (Gas)
Doug Anderson (812) 330-4031
205 S. Madison
Bloomington, IN 47404
danderson@vectren.com

CITY OF BLOOMINGTON UTILITIES (Water/Sewer)
Nancy Axsom (812) 349-3689
600 E. Miller Dr.
Bloomington, IN 47402
axsomm@bloomington.in.gov

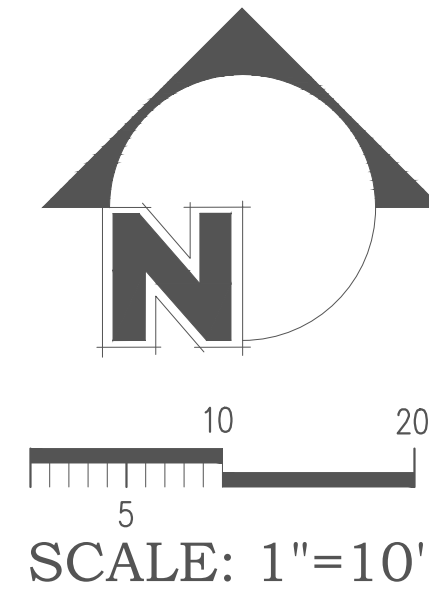

LEGEND

- | | | | |
|------------------------|-------------------------|----------------------------------|-------|
| ○ UTILITY POLE | ○ YARD INLET | — OVERHEAD WIRES | — OHW |
| ★ LIGHT POLE | ⊕ WATER VALVE | — SANITARY SEWER | — S |
| ← GUY WIRE | ⊕ WATER MANHOLE | — UNDERGROUND GAS LINE | — G |
| ⊕ ELECTRIC METER | ⊕ WATER METER | — UNDERGROUND ELECTRIC LINE | — E |
| ⊕ ELECTRIC MANHOLE | ⊕ FIRE HYDRANT | — UNDERGROUND COMMUNICATION LINE | — C |
| ⊕ ELECTRIC VAULT | ⊕ AIR CONDITIONER | — WATER LINE | — W |
| ⊕ ELECTRIC HANDHOLE | ⊕ GAS METER | — STORM SEWER | — ST |
| ⊕ ELECTRIC TRANSFORMER | ⊕ GAS VALVE | — FENCE | — X-X |
| ⊕ SANITARY MANHOLE | ⊕ COMMUNICATION MANHOLE | | |
| ⊕ CLEAN OUT | ⊕ COMMUNICATION VAULT | | |
| ⊕ STORM MANHOLE | ⊕ FIBER OPTIC MANHOLE | | |
| ⊕ CURB INLET | ⊕ FIBER OPTIC VAULT | | |
| ⊕ INLET ROUND | ⊕ CONCRETE BOLLARD | | |
| ⊕ INLET SQUARE | ⊕ SIGN | | |
| ⊕ AIR CONDITIONER | ⊕ PARKING METER | | |
| ⊕ BOLLARD | ⊕ ACCESSIBLE PARKING | | |
| | ○ TELEPHONE RISER | | |
| | ○ FIBER OPTIC RISER | | |

UTILITY NOTES

- ALL PROJECTS WILL REQUIRE A PRE-CONSTRUCTION MEETING WITH THE CITY OF BLOOMINGTON UTILITIES PRIOR TO THE START OF CONSTRUCTION. THE CONTRACTOR AND/OR DEVELOPER MUST CONTACT THE UTILITIES TECHNICIAN AT (812) 349-3676 TO SCHEDULE THE MEETING.
- CONTRACTOR SHALL NOTIFY THE CITY OF BLOOMINGTON UTILITIES ENGINEERING DEPARTMENT ONE (1) WORKING DAY PRIOR TO CONSTRUCTION OF ANY WATER OR SANITARY SEWER UTILITY WORK. A CBU INSPECTOR MUST HAVE NOTICE SO WORK CAN BE INSPECTED, DOCUMENTED, AND A PROPER AS-BUILT MADE. WHEN A CONTRACTOR WORKS ON WEEKENDS, A CBU DESIGNATED HOLIDAY, OR BEYOND NORMAL CBU WORK HOURS, THE CONTRACTOR WILL PAY FOR THE INSPECTOR'S OVERTIME. FOR CBU WORK HOURS AND HOLIDAY INFORMATION, PLEASE CONTACT THE CITY OF BLOOMINGTON UTILITIES ENGINEERING DEPARTMENT AT (812)349-3660.
- SEE SPECIFICATIONS FOR SIZES OF WATER SERVICE LINES AND SEWER LATERALS NOT SPECIALLY NOTED ON THE PLANS.
- MS.-; IF SHOWN ON THE PLANS, = MINIMUM SEWER ELEVATION. IT INDICATES THE LOWEST FLOOR ELEVATION THAT WILL ALLOW GRAVITY SEWER SERVICE WITHOUT A SPECIAL BACKWATER VALVE. ANY FLOOR ELEVATION THAT WILL BE SERVED BY GRAVITY SEWER MUST BE ABOVE THE RIM ELEVATION OF THE UPSTREAM SANITARY MANHOLE. IF NOT A BACKWATER VALVE MUST BE INSTALLED ACCORDING TO SEC. 409(A) OF THE UNIFORM PLUMBING CODE. SEE SPECIFICATIONS PACKET FOR MORE DETAIL.
- ON ALL EXISTING SANITARY MAINS, WYES SHALL BE CUT AND SLEEVED IN PLACE BY CITY OF BLOOMINGTON UTILITIES PERSONNEL WITH CITY OF BLOOMINGTON UTILITIES FURNISHING ALL MATERIAL, EQUIPMENT, AND LABOR NECESSARY FOR INSTALLATION. DEVELOPER SHALL PROVIDE ALL NECESSARY EXCAVATION, SHORING, BACKFILL, AND SURFACE REPAIR. PLEASE CONTACT NANCY AXSOM AT (812) 349-3689 FOR MORE INFORMATION.
- WHEN CONNECTING A NEW PIPE TO AN EXISTING MANHOLE, THE MANHOLE SHALL BE CORE-DRILLED. PIPE SHALL BE CONNECTED TO THE MANHOLE BY EITHER A FLEXIBLE BOOT KOR-N-SEAL 1 OR 2 FLEXIBLE CONNECTOR OR APPROVED EQUAL. TABLE AND TROUGH SHALL BE MODIFIED AS NECESSARY TO DIRECT THE FLOW FROM THE NEW PIPE. INVERT OF CONNECTION SHALL BE NO MORE THAN ONE FOOT HIGHER THAN THE INVERT OUT FOR THIS STRUCTURE.
- IN ACCORDANCE WITH SECTION 4.5.2.1.5.1. OF THE CBU CONSTRUCTION SPECIFICATIONS ALL SEWER LATERALS SHALL HAVE A CLEAN-OUT AT LEAST EVERY 90 FEET. ALL CLEAN-OUTS, WHETHER IN GRASSY AREAS OR IN PAVEMENT, SHALL BE SUB-SURFACE AND PROTECTED BY A SUITABLE METAL CASTING SUCH AS EAST JORDAN CATALOGUE NO. 2975 OR NEENAH CATALOGUE NO. R-1974-A. IN GRASSY AREAS, THE CASTING SHALL BE PROVIDED WITH A CIRCULAR CONCRETE COLLAR FLUSH WITH THE TOP OF THE CASTING AND THE GROUND SURFACE. THE COLLAR SHALL BE MINIMUM 6" THICK AND SHALL EXTEND AT LEAST 8" BEYOND THE OUTSIDE OF THE CASTING ON ALL SIDES. IN PAVEMENT, THE TOP OF THE CASTING SHALL BE FLUSH WITH THE SURROUNDING PAVEMENT. TOP OF CLEAN-OUT SHALL BE NO MORE THAN 3" BELOW THE TOP OF THE CASTING. A #10 INSULATED SOLID COPPER LOCATOR WIRE SHALL BE WRAPPED AROUND ALL NON-METALLIC PIPES SO THAT ONE REVOLUTION IS MADE AT LEAST EVERY PIPE JOINT. SPLICES ARE TO BE MADE WITH AN APPROVED CONNECTOR, AND ARE TO BE SUITABLY PROTECTED AGAINST CORROSION. THE WIRE IS TO BE BROUGHT TO THE SURFACE WITH A CLEAN-OUT IN A CASTING. ALSO SEE THE CBU CONSTRUCTION SPECIFICATIONS FOR THE "STANDARD SANITARY LATERAL CLEAN-OUT DETAIL #19".
- WHEREVER C900 PIPE IS USED FOR SEWER, ALL WYES SHALL BE HARCO, SIZED FOR C900 ON THE RUN AND SDR-35 ON THE BRANCH. TRANSITION FROM C900 TO SDR-35 PIPE SHALL BE MADE BY USE OF A HARCO C900 TO SDR-35 ADAPTER WYES.
- ALL D.I.P. USED FOR SANITARY SEWER SHALL HAVE CERAMIC EPOXY LINING, MINIMUM THICKNESS 40 MILS, AND SHALL BE PROTECTO 401, AS MANUFACTURED BY INDURON PROTECTIVE COATINGS. WYES FOR D.I.P. SHALL BE HARCO D.I.P. TO SDR-35 ADAPTER WYES.

GENERAL NOTES

- SEE SMITH DESIGN GROUP 2021 STANDARD SPECIFICATIONS FOR CONSTRUCTION REQUIREMENTS
- CONTRACTOR SHALL CONTACT WITH CITY PLANNING AND TRANSPORTATION, ENGINEERING AND CITY OF BLOOMINGTON UTILITIES FOR PRE CONSTRUCTION MEETING TO COORDINATE CONSTRUCTION SCHEDULES AND MAINTENANCE OF TRAFFIC.
- LOCATION OF EXISTING UTILITIES ARE TO BE VERIFIED IN THE FIELD BY THE CONTRACTOR. PLEASE NOTIFY ENGINEER IF FIELD ADJUSTMENTS ARE NECESSARY.
- TOP OF CASTING ELEVATIONS ARE GIVEN IN THE FOLLOWING LOCATIONS:
MANHOLES: RIM ELEVATION
INLETS: GUTTER ELEVATION

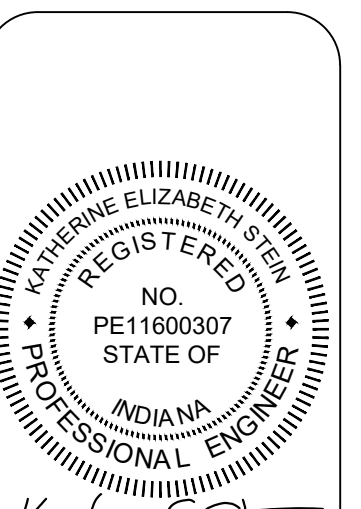

Kathleen Stein

09/27/2022

626 N. COLLEGE AVENUE
BLOOMINGTON, INDIANA

BY	DATE	REVISIONS
DK	4/3/23	CBU REVISIONS
DK	5/04/23	CBU REVISIONS
DK	8/23/23	PLANNING AND CBU REVISIONS
DK	10/11/23	PLANNING AND CBU REVISIONS

DESIGNED	DRAWN	CHECKED	DATE
DK	WDW		

JOB NUMBER
6396
SHEET
3 OF 7
DATE
10/11/2023

GRADING AND UTILITY PLAN

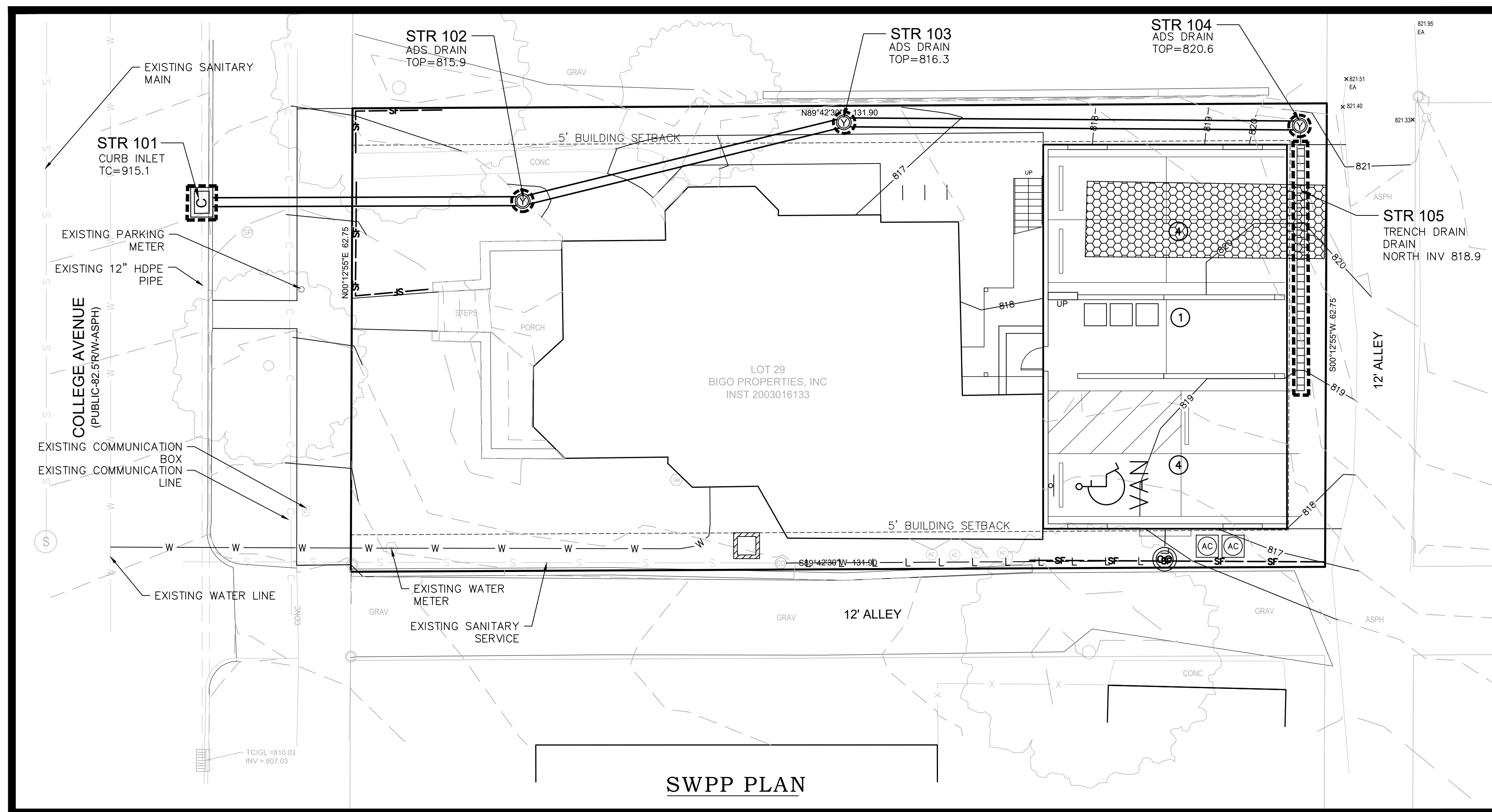

GENERAL CONSTRUCTION SEQUENCE

- PRIOR TO START OF CONSTRUCTION, CONTRACTOR SHALL COORDINATE A PRE-CONSTRUCTION MEETING WITH CITY PLANNING AND TRANSPORTATION AND CBU INSPECTORS TO REVIEW SCHEDULE OF EVENTS.
- POST THE LOCAL GRADING PERMIT.
- INSTALL TEMPORARY CONSTRUCTION IN LOCATION APPROVED BY PLANNING.
- INSTALL TEMPORARY SILT FENCE.
- CLEAR EXISTING CONSTRUCTION AREA.
- COMPLETE SITE EARTHWORK TO CREATE BUILDING PAD.
- INSTALL UTILITY INFRASTRUCTURE.
- INSTALL TEMPORARY CONCRETE WASHOUT. LOCATION MAY VARY BASED ON CONTRACTOR PREFERENCE, HOWEVER ENSURE COMPLIANCE WITH THE INDIANA STORM WATER QUALITY MANUAL.
- INSTALL AGGREGATE BASE FOR WALKS AND PAVEMENT.
- INSTALL CONCRETE PAVEMENT AND CONCRETE WALKS.
- REPLACE TOPSOIL IN LAWN AREAS AND AROUND BUILDING AND INSTALL LANDSCAPING.
- INSTALL PERMANENT LAWNS. MULCH SEED ALL DISTURBED LAWN AREAS.
- REMOVE ANY ACCUMULATED SEDIMENT FROM THE STRUCTURES AND SITE.
- ONCE LAWNS ARE ESTABLISHED, REMOVE SILT FENCE AND OTHER EROSION CONTROL MEASURES AND PATCH ANY BARE SPOTS.

SWPP GENERAL REQUIREMENTS

- PRIOR TO START OF CONSTRUCTION, CONTRACTOR TO COORDINATE PRE-CONSTRUCTION MEETING WITH CITY PLANNING.
- ANY BARE EARTH AREAS REMAINING IDLE FOR MORE THAN 7 DAYS SHALL BE TEMPORARY MULCHED SEEDING IN ACCORDANCE WITH THE TABLE SHOWN BELOW OR PERMANENTLY SEEDED AFTER FINISH GRADING. CONTACT CITY OF BLOOMINGTON PLANNING AND TRANSPORTATION FOR CLARITY IF NEEDED ON TEMPORARY OR PERMANENT SEEDING.
- CONTRACTOR IS RESPONSIBLE FOR MAINTAINING ALL EROSION CONTROL DEVICES DURING CONSTRUCTION AND INSTALLING SUPPLEMENTAL EROSION CONTROL MEASURES AS REQUIRED.
- CONTRACTOR SHALL INSPECT ALL EROSION CONTROL DEVICES PRIOR TO AND IMMEDIATELY FOLLOWING ANY 1/2 INCH RAIN EVENT.
- IF FUELING ON-SITE IS NECESSARY, NOTIFY ENGINEER OF LOCATION TO SHOW ON SWPPP.
- EROSION CONTROL BLANKETS SHALL BE 100% BIODEGRADABLE. PLASTIC NETTING IS NOT PERMITTED.

SEED SPECIES	RATE/ACRE	PLANTING DEPTH	OPTIMUM DATES
WHEAT OR RYE	150 LBS	1 TO 1 1/2 IN.	9/5 TO 10/30
SPRING OATS	100 LBS	1 IN.	3/1 TO 4/15
ANNUAL RYEGRASS	40 LBS	? IN.	3/1 TO 5/1 8/1 TO 9/1
GERMAN MILLET	40 LBS	1 TO 2 IN.	5/1 TO 6/1

* PERENNIAL SPECIES MAY BE USED AS A TEMPORARY COVER, ESPECIALLY IF THE AREA TO BE SEEDING WILL REMAIN IDLE FOR MORE THAN A YEAR (PRACTICE 3.10)
 ** SEEDING SOME OUTSIDE THE OPTIMUM DATES INCREASES THE CHANCES OF SEEDING FAILURE.

EROSION CONTROL LEGEND

- TEMPORARY CONSTRUCTION ENTRANCE
- CONCRETE WASHOUT
- BAG CURB INLET PROTECTION
- YARD INLET PROTECTION
- SILT FENCE

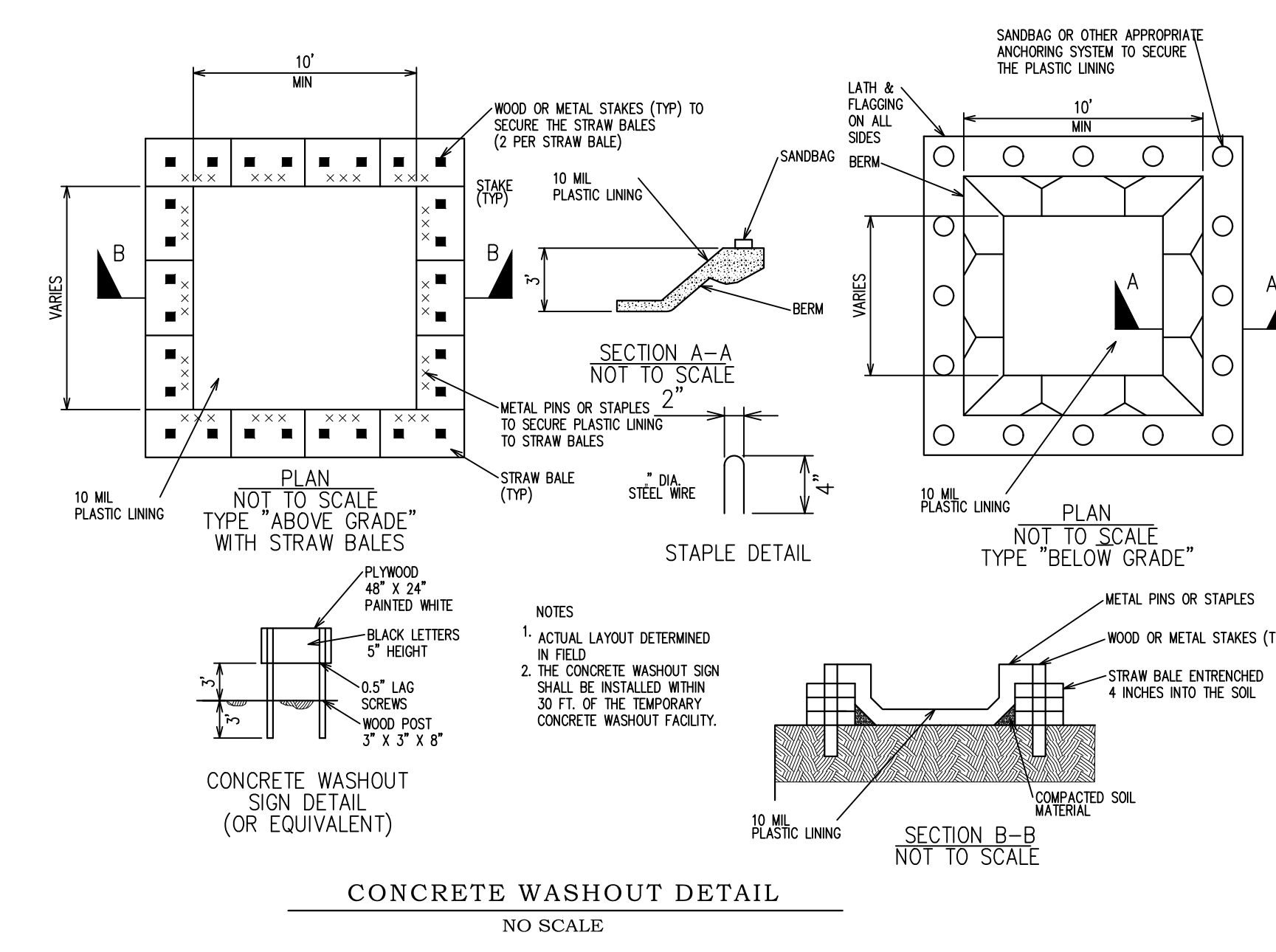
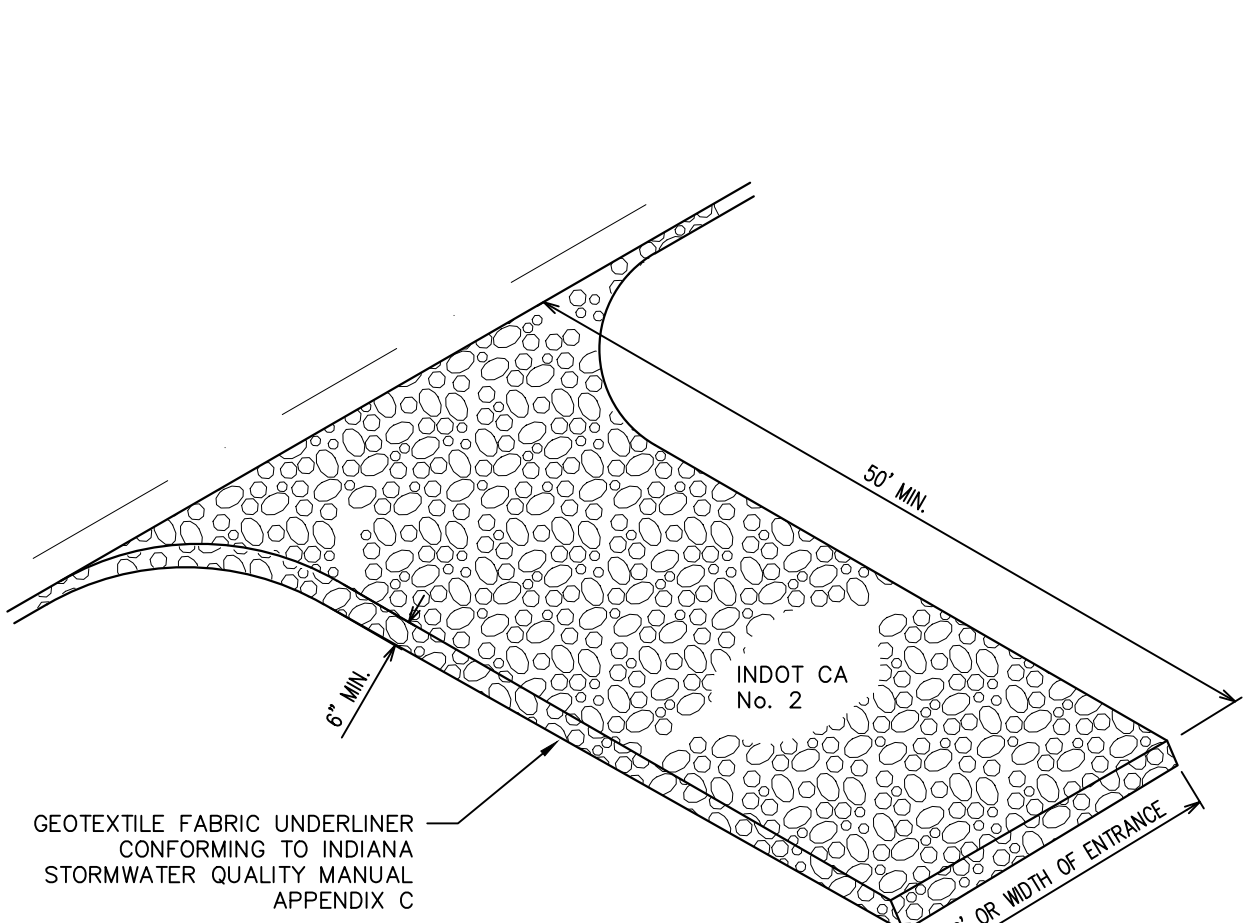
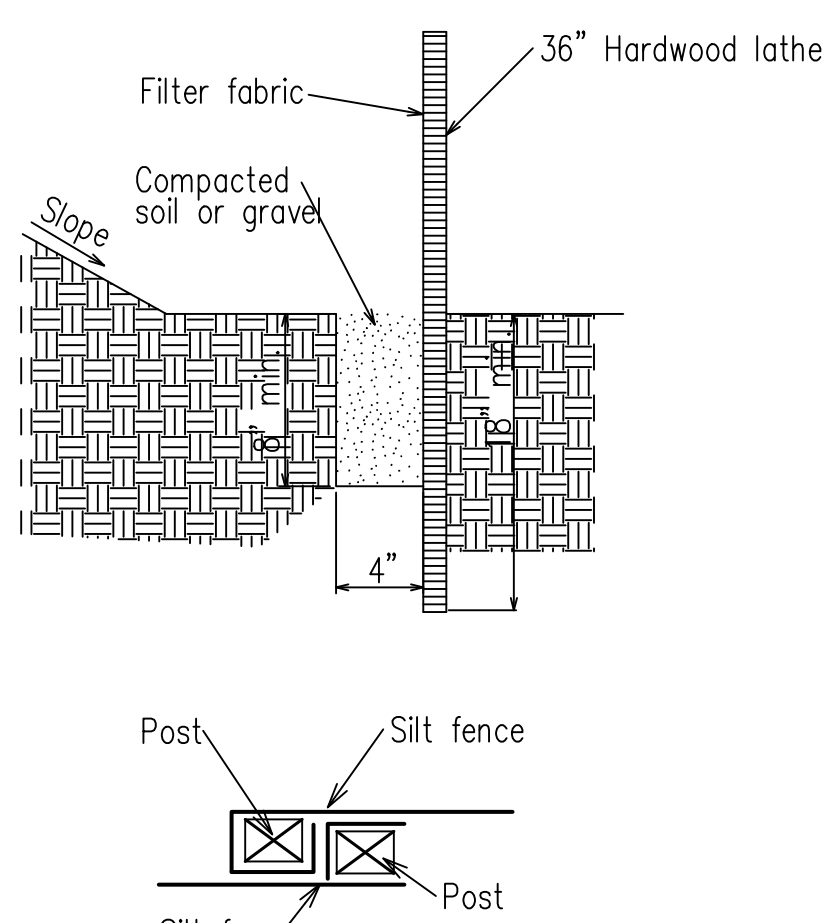
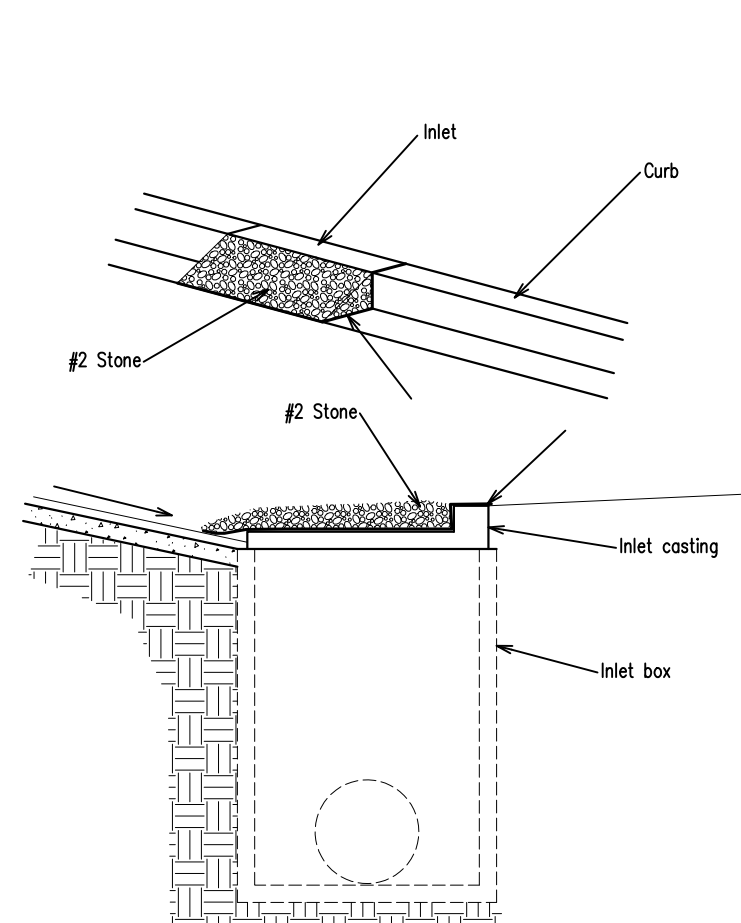
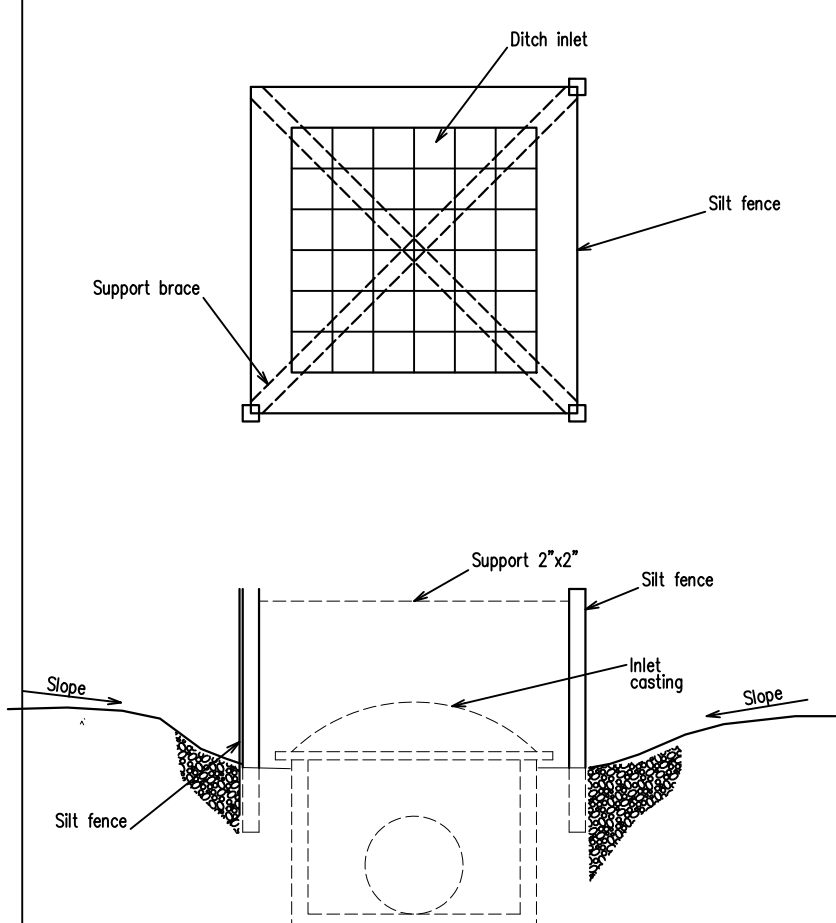

GENERAL NOTES

- SEE SMITH DESIGN GROUP 2021 STANDARD SPECIFICATIONS FOR CONSTRUCTION REQUIREMENTS.
- CONTRACTOR SHALL CONTACT WITH CITY PLANNING AND TRANSPORTATION, ENGINEERING AND CITY OF BLOOMINGTON UTILITIES FOR PRE CONSTRUCTION MEETING TO COORDINATE CONSTRUCTION SCHEDULES AND MAINTENANCE OF TRAFFIC.
- LOCATION OF EXISTING UTILITIES ARE TO BE VERIFIED IN THE FIELD BY THE CONTRACTOR. PLEASE NOTIFY ENGINEER IF FIELD ADJUSTMENTS ARE NECESSARY.
- TOP OF CASTING ELEVATIONS ARE GIVEN IN THE FOLLOWING LOCATIONS:
 MANHOLES: RIM ELEVATION
 INLETS: GUTTER ELEVATION

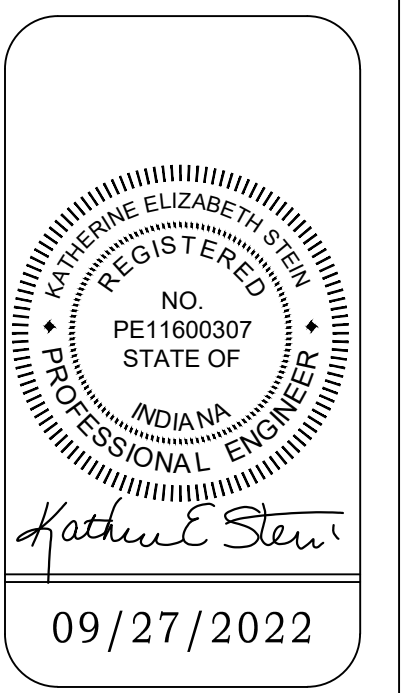
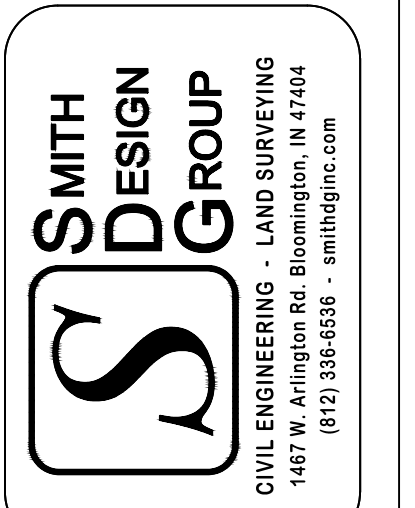

626 N. COLLEGE AVENUE
 BLOOMINGTON, INDIANA

REVISIONS	BY	DATE
CBU REVISIONS	DK	4/3/23
CBU REVISIONS	DK	5/04/23
PLANNING AND CBU REVISIONS	DK	8/23/23
REVISIONS	DK	10/11/23

DESIGNED	DRAWN	CHECKED	DATE
DK	WDW		

JOB NUMBER
6396
 SHEET
4 OF 7
 DATE
 10/11/2023
 SWPP PLAN

SECTION 02420

STORMWATER POLLUTION PREVENTION & EROSION CONTROL

PART 1 - GENERAL

1.01 RELATED WORK

- A. Section 02310 - Rough Grading
B. Section 02320 - Finish Grading
C. Section 02930 - Sodding
D. Section 02910 - Protection for Existing Trees

1.02 REFERENCES

- A. The latest issue of the following form a part of this section to the extent indicated hereinafter:
1. Indiana Storm Water Quality Manual published by the Indiana Department of Environmental Management October 2007 edition. (ISWQM)
2. Indiana Code 327 IAC 15-5-7 Section 7.

1.03 LOCAL JURISDICTION

- A. When the work is within the jurisdiction of a local municipality, MS4 district or Soil and Water Conservation District that will inspect, review, approve, reject or report on part or all of the work being completed, the specifications and requirements of that agency shall supersede this section of the standard specifications if said agency's specifications and requirements are more stringent.

PART 2 - PRODUCTS

2.01 MATERIALS

- A. Aggregates for use in conjunction with erosion control measures shall be in accordance with the section of the INDOTSS indicated as follows:
1. Coarse aggregates size #2, #5, #8, and #53 shall be in accordance with Section 904.03 table (e).
2. Rip rap for outlet protection materials shall be in accordance with Section 904.04 table (f) of the INDOTSS and Chapter 7 of the ISWQM.
B. Pipe material for use in conjunction with erosion control measures shall be in accordance with the section of the INDOTSS indicated as follows:
1. Corrugated Polyethylene Drainage Tubing and Smooth Wall Polyethylene Pipe shall be in accordance with Section 907.17 and 907.21 of the INDOTSS.
C. Geotextile
1. Geotextiles for use under rip rap shall be in accordance with Section 918.02 of the INDOTSS.
D. Silt Fence shall conform to the minimum physical properties as shown on the table below.

Table with 3 columns: Physical Property, Woven fabric, Non-woven fabric. Rows include Filtering efficiency (85%), Tensile strength at 20% elongation, Standard strength (30 lbs./linear in., 50 lbs./linear in.), Extra strength (50 lbs./linear in., 70 lbs./linear in.), Slurry flow rate (0.3 gal./min./sq.ft., 4.5 gal./min./sq.ft.), Water flow rate (15 gal./min./sq.ft., 220 gal./min./sq.ft.), UV resistance (70%, 85%), Post Spacing (7 feet, 5 feet).

- E. Temporary Gravel Construction Entrances
1. Construction entrances shall be installed using materials specified in ISWQM Chapter 7.
F. Erosion Control Blankets
1. Erosion control blankets and turf reinforcement shall be the type indicated on the plans as manufactured by North American Green or equal approved by Owner's Representative. Blankets shall be made up of 100% biodegradable material. Plastic netting is not permitted.
G. Temporary Seeding
1. Grass species required for temporary seeding shall be as follows during these time periods:
Winter wheat or rye 9/15 to 10/30
Spring oats 3/1 to 4/15
Annual ryegrass 3/1 to 5/1, 8/1 to 9/1
German millet 5/1 to 6/1
H. Mulching Material
1. Mulching material may be straw or hay, Excelsior blankets, paper mat, straw mat or ospen wood cellulose fiber mulch.

PART 3 - EXECUTION

3.01 SCHEDULING/SEQUENCING

- A. Existing Vegetation
1. If existing vegetation must be cleared, it shall be retained and protected until the area must be disturbed.
2. A buffer strip of existing vegetation must be maintained around the perimeter of the site to reduce off-site erosion and sedimentation.
B. Duration
1. The extent and duration that bare soil is exposed to erosion by wind and water should be minimized. Clearing and grading operation shall be scheduled to reduce the amount of disturbed area to the absolute minimum needed for immediate construction activity.
C. Stabilization
1. All disturbed ground left inactive for seven or more days shall be stabilized appropriately for the season. Steep slopes must be stabilized immediately.
2. Soil storage or excavated material piles remaining more than seven days shall be stabilized by temporary or permanent seeding, sodding, traps, or other means. Erosion from piles that will be in existence for less than seven days shall be controlled by placing straw bales or silt fence barriers.

3.02 INSTALLATION AND MAINTENANCE

- A. All installation of erosion control devices and maintenance shall be in accordance with Section 205 on the INDOTSS and Section 7 of the ISWQM.
B. Temporary gravel construction entrance
1. Remove existing vegetation and topsoil from entrance area.
2. Install a culvert pipe under the drive if necessary to maintain proper public road drainage.

- 3. Compact subgrade soil prior to placing slane.
4. Place #2 stone to the dimensions indicated on the plan and in the Temporary Gravel Construction Entrance Detail.
5. Inspect entrance pad daily and after storm events or heavy use.
6. Reshape pad as needed for drainage and runoff control.
7. Top dress with clean stone as needed.
8. Immediately remove mud and sediment tracked or washed onto public roads by brushing or sweeping. Flushing should only be used if the water is conveyed into a sediment trap or basin.
9. Repair any broken road pavement immediately.

- C. Temporary Diversion Ditch
1. Remove brush, trees, stumps, and debris from route of diversion.
2. Set alignment and grades to fit site needs, maintaining a stable and positive grade towards the outlet.
3. Construct diversion in accordance with the Temporary Diversion Ditch Detail and at the location indicated on the plans.
4. Construct the diversion ridge in six to eight inch lifts.
5. Compact each lift by driving wheels of construction equipment along the ridge.
6. Overfill and compact ridge to design height plus 10 percent.
7. Leave sufficient area along the diversion to permit clean-out and regrading.
8. Vegetate the ridge immediately after construction, unless the diversion will be in place less than 15 days.
9. Inspect weekly and within 24 hours following each storm event.
10. Remove sediment from the channel and reinforce the ridge as needed.
11. Check outlets and make necessary repairs immediately.
12. When the work area has been stabilized, remove the ridge, fill the channel to blend with the natural ground, remove temporary slope drains, and stabilize all disturbed areas.

- D. Rock Check Dam
1. Excavate a cut-off trench into the channel bottom and ditch banks at the locations shown on the plan, extending 18 inches beyond the top of ditch bank.
2. Place uniform or revetment rip rap in the cut-off trench and channel in accordance with the Rock Check Dam Detail. The center of the dam must be at least nine inches lower than the uppermost points of contact between the rip rap dam and channel banks.
3. Extend rip rap at least 18 inches beyond the channel banks to prevent overflow water from undercutting the dam as it re-enters the channel.
4. Place filter medium on the up-slope side of the dam and over the entire face of the dam up to the base of the overflow weir notch.
5. Inspect check dams and the channel weekly and within 24 hours after each storm event, and repair any damage immediately.
6. If significant erosion occurs between dams, install a riprap liner in that portion of the channel.
7. Remove sediment accumulated behind each dam when it reaches one-half the height of the dam to maintain channel capacity, to allow drainage through the dam, and to prevent large flows from displacing sediment.
8. Add rock to the dams as needed to maintain design height and cross section.
9. When the dams are no longer needed, remove the rock and stabilize channel, using an erosion-resistant lining if necessary.

- E. Rock Lined Chute.
1. Divert surface water runoff around the structure during construction so site can be properly dewatered.
2. Excavate the apron area subgrade below the design elevation of finished grade to allow for thickness of rip rap at the locations shown on the plans.
3. Compact the subgrade.
4. Place the geotextile fabric on the compacted subgrade. If more than one piece is needed, the upstream piece should overlap the downstream piece by one-foot minimum.
5. Install rip rap in accordance with the Rock Chute Detail and the rip rap quantity given in the structure data table on the plans.
6. Top of the rip rap chute shall be level with or slightly below the receiving channel.
7. Blend the rip rap chute smoothly to the surrounding grade.
8. Construct a small plunge pool within the outlet apron.
9. Rip rap aprons must be level with or lower than the channel grade and should not restrict flow.
10. Construct a permanent diversion ridge on either side of the riprap lined chute to collect storm water runoff and direct its flow into the chute.
11. Inspect rock chutes 24 hours after storm events and at least every 7 days for stone displacement and for erosion at the sides and ends of the apron.
12. Make needed repairs immediately, use appropriate size stone, and do not place them above finished grade.

- F. Inlet Protection
1. Stone
a. Excavate the basin around the inlet one to two feet deep below the top of casting elevation in accordance with the Inlet Protection Detail.
b. Stockpile or spread excavated material so that it will not block flow or wash back into the excavation.
c. Install weep holes in the inlet so that the pool area drains slowly.
d. Cover weep holes with filter fabric and one foot of #5 stone.
e. If necessary, excavated material may be placed on the downstream side of the excavation to prevent by-pass flow.
f. Inspect the inlet protection within 24 hours after each storm event, removing sediment and making needed repairs immediately.
g. When the contributing drainage area has been stabilized, remove and properly dispose of all construction material and sediment, then stabilize.
h. Remove sediment when pool area is approximately one-half full of sediment.
i. Remove and replace stone if sediment hinders drainage.
j. Once permanent stabilization occurs, remove sediment basin, weep holes, fill basin with soil, compact and grade to finished elevation.
2. Silt Fence.
a. Dig an eight-inch deep, four-inch wide trench around the perimeter of the inlet.
b. If using pre-assembled silt fence and posts, drive the posts into the soil, tightly stretching the silt fence and posts by placing a piece of lathe over the fabric and fastening it to the post.

- c. If assembling the silt fence and post on-site, drive the posts into the soil and then secure the silt fence to the posts by placing a piece of lathe over the fabric and fastening it to the post.
d. Use the wrap join method when joining posts.
e. Place the bottom 12 inches of silt fence into the eight-inch deep trench, laying the remaining four inches in the bottom of the trench and extending away from the inlet.
f. Backfill the trench with soil material and compact it in place.
g. Brace the posts by nailing braces into each corner posts or utilize rigid poles to support fabric.
h. If storm water may bypass the structure, set the top of the silt fence at least six inches lower than the ground elevation on the down-slope side of the storm inlet, build a temporary dike compacted six inches higher than the silt fence on the down-slope side of the storm inlet and use in conjunction with excavated drop inlet protection.
i. Inspect daily and within 24 hours after each storm event and make needed repairs immediately.
j. Remove sediment from the pool area to provide storage for the next storm. Avoid damaging or undercutting the fabric during sediment removal.
k. When the contributing drainage area has been stabilized, remove and properly dispose of all construction material and sediment, grade the area to the elevation of the top of the inlet, then stabilize.
G. Curb Inlet Protection.
1. Fill UV stabilized geotextile fabric bags approximately full with washed gravel or aggregate.
2. For inlets located on a slope gradient:
a. At a position up slope of the inlet, lay bags tightly in a row curving up slope from the inlet and away from the curb.
b. Overlap bags onto the curb and extend a minimum of three feet into the street, keeping bags tightly abutted together.
c. For additional layers of bags, overlap the bags with the row beneath and leave a one-bag gap (at or below curb height) in the middle of the top row to serve as a spillway. If the spillway height is higher than the top of the curb, place additional bags along the curb to prevent bypass flow.
d. For additional storage capacity, construct a series of stone bag barriers along the curb so each one traps small amounts of sediment.

- 3. For inlets located in a sump position:
a. Place bags in an arc around the curb inlet.
b. Overlap bags onto the curb, keeping bags tightly abutted together.
c. For additional layers of bags, overlap the bags with the row beneath and leave a one-bag gap (at or below curb height) in the middle of the top row to serve as a spillway. If the spillway height is higher than the top of the curb, place additional bags along the curb to prevent bypass flow.
4. Place a traffic barricade at each installed measure for safety and to prevent measure integrity.
5. Inspect daily and removed accumulated sediment from paved area (do not flush with water) within 24 hours after each storm event.
6. Deposit sediment in area where it will not re-enter the paved area or storm drains.
7. Inspect for damage by vehicular traffic and repair if needed.
8. When the contributing drainage areas have been stabilized, remove inlet protection.
H. Temporary Sediment Trap.
1. Divert run-off from non-disturbed areas away from the trap.
2. Clear all existing vegetation and topsoil from the embankment area.
3. Using compactable material, construct the embankment at the location indicated on the plans and in accordance with the Temporary Sediment Trap Detail.
4. Construct the embankment six inches above design elevation to allow for settling.
5. Excavate a trapezoidal outlet section from the embankment.
6. Install geotextile fabric in the trapezoidal outlet section, extending the fabric up the sides of the outlet section to the top of the embankment.
7. Place INDOT revetment rip rap in accordance with the detail to create a dense mass. The spillway crest must be level with a minimum depth of 1 foot, measured from the highest stones in the spillway weir notch to the top of the dam.
8. Cover the upstream face of the riprap outlet section with a 12-inch thick layer of INDOT CA No.5 aggregate.
9. On the downstream side of the spillway, construct an outlet apron at the toe of the embankment. Construct the apron as indicated on the plans and in accordance with the Temporary Sediment Trap Detail.
10. Place geotextile fabric or aggregate bedding material on the compacted and smoothed foundation and install riprap as indicated on the plans and in accordance with the Temporary Sediment Trap Detail.

- 11. Construct a small plunge pool within the outlet apron. Riprap aprons must be level with or slightly lower than the receiving channel and should not produce an overflow or restrict flow of the water conveyance structure.
12. Stabilize the embankment and other disturbed areas with seed and mulch (anchored in place) or another suitable erosion resistant cover.
13. Inspect within 24 hours of a rain event and at least once every seven days.
14. Remove sediment when it has accumulated to one-half the design volume.
15. Check the embankment for erosion and piping holes and repair immediately.
16. Check pool area side slopes for erosion and repair immediately.
17. Replace spillway aggregate facing is the sediment pool does not dewater with 48-72 hours following a storm water runoff event.
18. Inspect vegetation and reseed if necessary.
19. Check the spillway depth periodically to ensure a minimum of 1foot depth from the lowest point of the settled embankment to highest point of the spillway crest, and fill any low areas to maintain design elevation.
20. Promptly replace any displaced riprap, being careful that no stones in the spillway are above design grade.
21. After all disturbed areas have been stabilized, remove the structure and sediment, smooth the site to blend with adjoining areas, and stabilize.

I. Silt Fence.

- 1. Plan for the fence to be at least ten feet from the toe of the slope to provide a sediment storage area.
2. Provide access to the area for maintenance.
3. Locate silt fence outlet at location shown on the plans.
4. Locate the outlet weir posts four feet apart and place a 2 X 4 horizontal brace between the posts.
5. Excavate the foundation for the outlet one foot deep, five feet wide and a minimum of five feet in length.
6. Install uniform rip rap in the outlet area.
7. Along the entire intended fence line, dig an eight inch deep by four-inch wide trench.
8. Install the silt fence with filter fabric located on the up-slope side of the excavated trench and the support posts on the down-slope side of the trench.
9. Install support posts at least 18 inches into the ground, tightly stretching the fabric between the posts as each is driven into the soil. A minimum of 12 inches of the filter fabric should extend into the trench.
10. Lay the lower four inches of filter fabric on the bottom of the trench and extend it toward the up-slope side of the trench.
11. Backfill the trench with compacted earth or gravel.
12. Inspect the silt fence at least every seven days and within 24 hours after each storm event.
13. If fence fabric tears, starts to decompose, or in any way becomes ineffective, replace the affected portion immediately.
14. Remove deposited sediment when it is causing the filter fabric to bulge or when it reaches half the height of the fence at its lowest point or is causing the fabric to bulge.
15. Take care to avoid undermining the fence during clean out.
16. After the contributing drainage area has been stabilized, remove the fence and sediment deposits, bring the disturbed area to grade, and stabilize.

J. Temporary Seeding

- 1. Determine the appropriate seed species based on the optimum dates for planting as shown in the table below.
2. Apply seed uniformly with a drill or culti-packer - seeder or by broadcasting and cover to the depth as shown in the table below.
3. Mulch seeded areas in accordance seed mix below.
4. Inspect weekly after planting to see that vegetative stands are adequately established; re-see if necessary.
5. Check for erosion damage within 24 hours after storm events and repair; reseed and mulch if necessary.
6. Topdress fall seeded wheat or rye seedings with 50 lbs/acre of nitrogen in February or March if nitrogen deficiency is apparent.

Table with 4 columns: Seed Species, Rate/acre, Planting Depth, Optimum dates**. Rows include Wheat or rye, Spring oats, Annual ryegrass, German millet.

3.03 MAINTENANCE & INSPECTIONS

- A. The general contractor is responsible for inspection and determining that erosion control measures are installed as shown on the plans. Inspection of all storm water pollution prevention practice measures shall be made by a trained individual on a weekly basis and after every 0.5 inch rainfall event. Records of inspections made and corrective measures taken shall be recorded and kept in a location where they may be made available to the Monroe County MS4 Operator or their Assistant and Indiana Department of Environmental Management inspectors within a 48 hr time frame should they be requested.
B. Additional erosion control measures may need to be installed based on the prosecution of the work.
C. Removal of accumulated sediment from any erosion control device is required throughout construction. Failure to remove accumulated sediment can result in failure of the device. Failure of any erosion control device will result in the required re-installation of said device.

3.04 CLEAN UP

- A. When construction is completed and the area is stabilized, remove erosion control measures no longer necessary in a manner that minimizes site disturbance and seed immediately.
B. All silt, dust or debris shall be cleaned from adjoining public streets, if necessary, immediately following a storm event and at the completion of the project. Remove sediment tracking of public streets as needed or at the end of each working day.

PART 4 - MATERIAL HANDLING, SPILL PREVENTION & SPILL CLEAN UP

4.01 MATERIAL HANDLING & SPILL PREVENTION

- A. Throughout construction operators of equipment that carry potential pollutants shall take every available measure to prevent possible spills. Vehicle operators of all kinds shall not allow the seepage or dumping of potential contaminant fluids or other contaminant materials onto the ground. Vehicle washing and fluid changing shall take place offsite at areas set up to prevent the possibility of contaminants entering the ground water or at designated areas on site.
B. Used oils, fuels, antifreeze and other materials may be considered hazardous and must be disposed of at approved sites. For disposal site information contact the IDEM at 888-233-7745.
C. Place all drained lubricants, fuels, etc. in closed containers. Remove them from the site for disposal or recycling in accordance with all Federal, State and Local requirements.
D. Drain oil filters when hot and dispose of used filters, oil cans and grease tubes properly. Drained metal cans and filters can be recycled as scrap metal.
E. Maintain all equipment to avoid leaks.
F. Concrete Waste Management -
1. Concrete waste management procedures and practices are implemented on construction projects where:
a. Concrete is used as a construction material or where concrete dust and debris result from demolition activities.
b. Slurries containing Portland cement concrete or asphalt concrete are generated, such as from saw cutting, coring, grinding, grooving, and hydro-concrete demolition.
c. Concrete trucks and other concrete-coated equipment are washed onsite.
d. Mortar-mixing stations exist.

- 2. Perform washout of concrete trucks offsite or in designated areas only. For onsite washout, a sign should be installed adjacent to the washout facility to inform concrete equipment operators to utilize the proper facilities. One of the following methods may be used: 1.) Use of a delayed set additive. Washout occurs offsite in an area where washout water is treated before coming into contact with environment. 2.) Recycle washout water back into the cement truck. 3.) KIC system (www.kicsystems.com) - driver washes out into a barrel that is then removed from site. 4.) Concrete Washout Inc. (www.concretewashout.com) trucks wash out into a dumpster like system and then dry concrete is removed. Use of other methods may be used if approved by the local MS4 or Soil and Water Conservation District.
3. Installation of Concrete Washout Facilities
a. Prefabricated or Design and Installed Systems are acceptable.
b. For prefabricated systems, install and locate according to manufacturer's recommendations.
c. For Designed and installed systems, either excavate a pit or install the containment system.
d. Install the polyethylene lining. For excavated systems, the lining should extend over the entire excavation. The lining for bermed systems should be installed over the pooling area with enough material to extend the lining over the berm or containment system. The lining should be secured with pins, staples or other fasteners.
e. Place flags, safety fencing or equivalent to provide a barrier to construction equipment and other traffic.
f. Install signage that identifies concrete washout areas.
g. Post signs directing contractors and suppliers to designated locations.
4. Maintenance of concrete washout facilities
a. For prefabricated systems follow the manufacturer's recommendations for maintenance.
b. Inspect daily and after each concrete pour.
c. Inspect the integrity of the overall structure including, where applicable, the containment system.
d. Inspect the system for leaks, spills and tracking of soil by equipment.
e. Inspect the polyethylene lining for failure, including tears and punctures.
f. Once concrete wastes harden, remove and dispose of the material.
g. Excess concrete should be removed when the washout system reaches 50 percent of the design capacity. Use of the system should be discontinued until appropriate measures can be initiated to clean the structure.
h. Repair the structure as needed or construct a new system upon removal of the solids.
i. Dispose of all concrete in a legal manner. Reuse the material on site, recycle or haul the material to an approved construction/demolition landfill site.
j. The plastic liner should be replaced after every cleaning.
k. The concrete washout system should be repaired or enlarged as necessary.
l. When concrete washout systems are no longer required, the concrete washout systems shall be closed. Dispose of all hardened concrete and other materials used to construct the system.
5. Washout Procedures
a. Do not leave excessive mud in the chutes or hopper after the pour.
b. At washout location, scrape as much material from the chutes as possible before washing them.
c. Remove as much mud as possible when washing out.
d. Do not back flush the equipment at the project site.
e. Do not use additives with wash water. Do not use solvents or acids that may be used at the target plant.

4.02 SPILL CLEAN UP

- Any spills that occur on the ground or any other surface shall be cleaned up immediately.
A. Expected construction materials on site may include vehicle lubricants, oils, vehicular fuels, concrete wash-outs, acids, curing compounds, paints, solvents, pesticides, herbicides, fertilizers.
B. Small spills and leaks of these materials onto paved areas shall be shoveled into containers and disposed of in accordance with all Federal, State and Local regulations. Provide receptacles, a spill kit and instructions for use in breakdown situations. At a minimum, the spill kit should include shovels, plastic sheeting for containment, plastic container to hold spill contaminated material, 2 bags of absorbent (dry sand, oil-dry, kitty litter, peat moss, ground corncobs, sawdust and new straw are suitable absorbing materials). If a spill occurs contact IDEM and local MS4 Coordinator immediately. Post emergency contact information on sign board along with all permits: NOI, Construction in a Floodway, Letter of Sufficiency, etc.
C. Spills may be temporarily handled by: 1.) placing contaminated materials on heavy plastics and covering to protect from rainfall; 2.) using absorbents to soak up spilled materials or easy removal; 3.) constructing a dike to prevent off site movement of material. If possible, vehicle maintenance shall be completed offsite at a facility designed to handle any spillage, this shall include fueling of vehicles when possible. The local fire department, Indiana Department of Environmental Management Emergency, Office of Emergency Response 1-888-233-7745 shall be notified immediately for larger spills or leaks. The National Response Center (800) 424-8802 shall be notified and provided with the following information: Time of Spill, Location of Spill, Material, Source of Spill, Approximate Volume and Length of Spillage, Weather Conditions at the Time of the Spill, Personnel Present at Time of the Spill and All Action Taken for Post Spill Clean-up.
D. Contractor shall contact a waste recovery agency immediately following the spill for removal of contaminants and coordination of monitoring the site during clean-up operations until all hazardous material has been removed. Contractor shall coordinate with the Indiana Department of Environmental Management during and after the spill to insure all required clean-up and filing of reports are properly submitted. Responsibility for reporting spills is outlined in IAC 327 2-6.1-7 (4).
E. The Contractor shall maintain a list of qualified contractors for spill remediation on site. All site personnel, including maintenance employees, shall be made aware of proper spill prevention and remediation techniques.

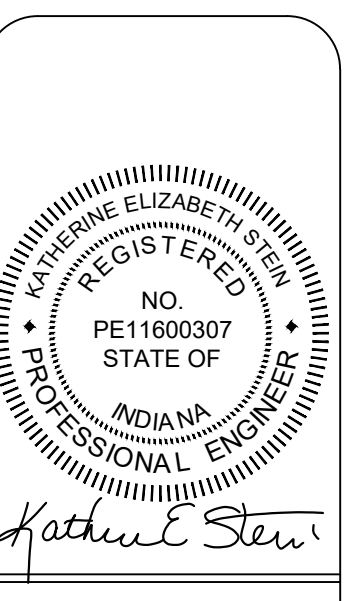

09/27/2022

626 N. COLLEGE AVENUE BLOOMINGTON, INDIANA

Table with columns: REVISIONS, BY, DATE. Rows for CBU REVISIONS, CBV REVISIONS, PLANNING AND CBU REVISIONS, PLANNING AND CBU REVISIONS.

Table with columns: DESCRIBED, CHECKED, DATE. Rows for DK, DW, WDW.

JOB NUMBER 6396 SHEET 5 OF 7 DATE 10/11/2023 SWPP SPECS

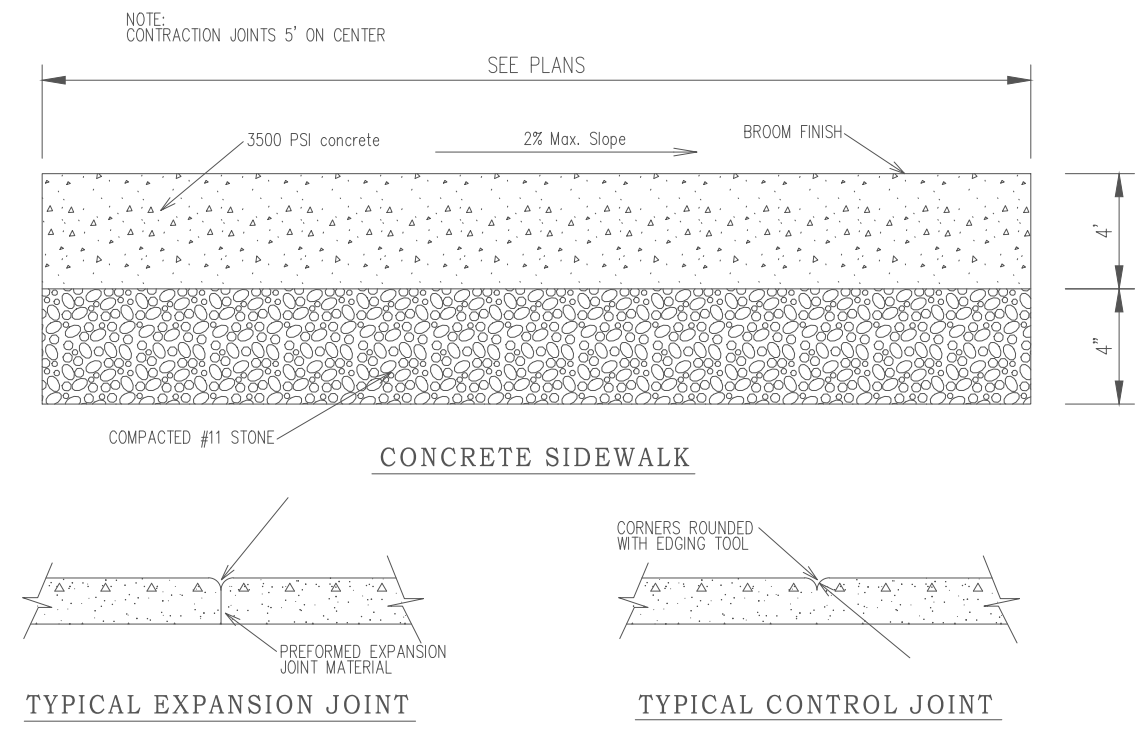

CONCRETE SIDEWALK DETAIL
NO SCALE

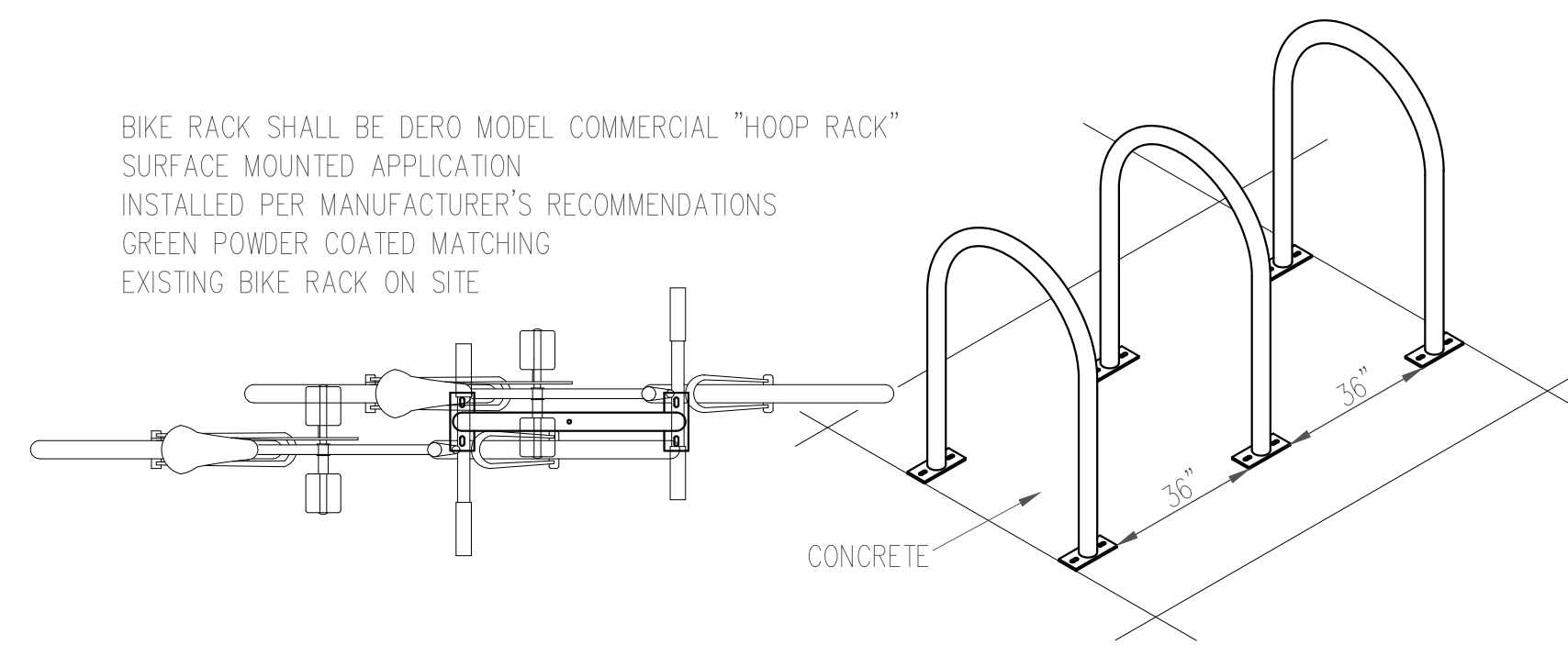

BIKE RACK DETAIL
NO SCALE

BIKE RACK SHALL BE DERO MODEL COMMERCIAL "HOOP RACK" SURFACE MOUNTED APPLICATION INSTALLED PER MANUFACTURER'S RECOMMENDATIONS GREEN POWDER COATED MATCHING EXISTING BIKE RACK ON SITE

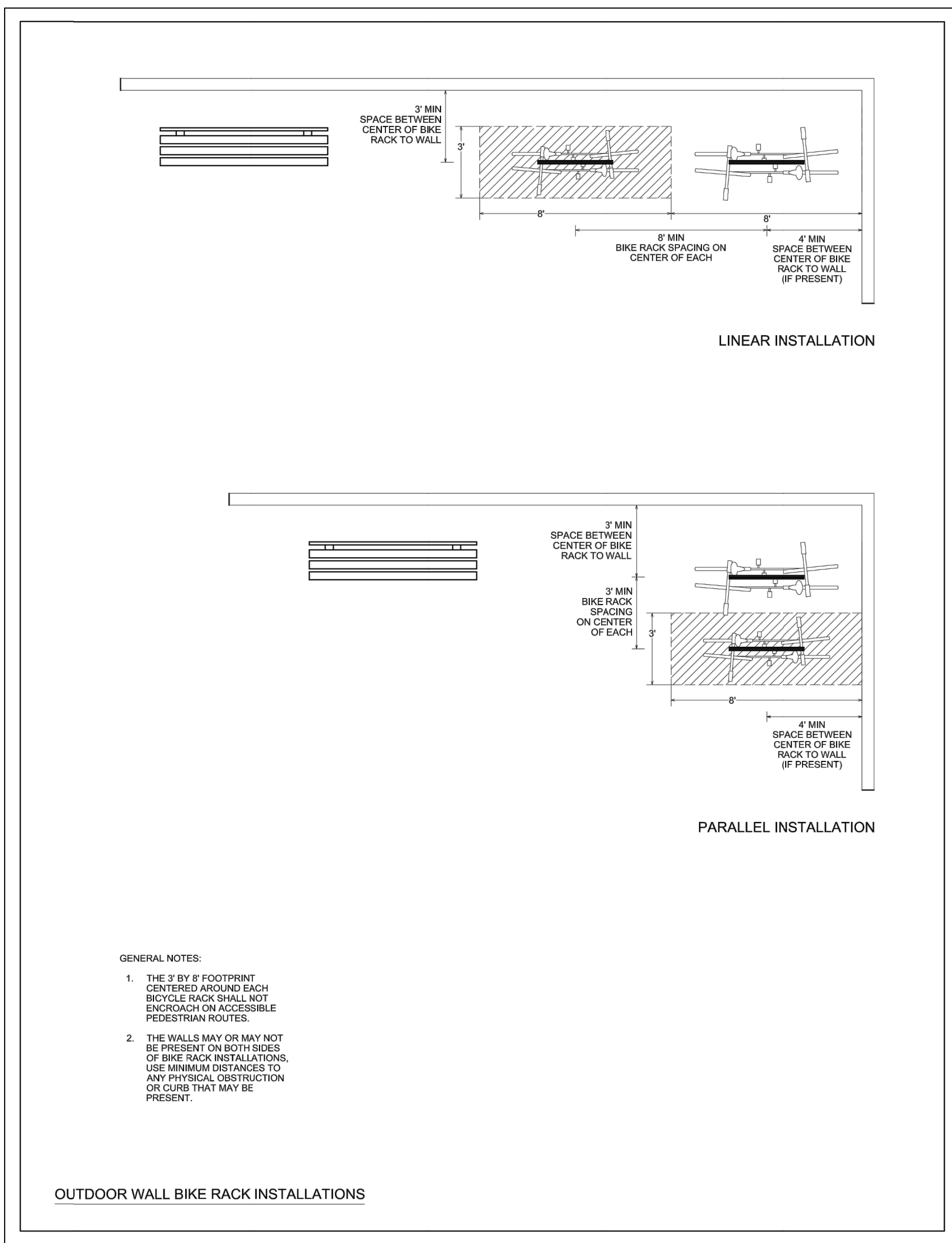

OUTDOOR WALL BIKE RACK INSTALLATIONS

- GENERAL NOTES:**
1. THE 3' BY 6' FOOTPRINT CENTERED AROUND EACH BICYCLE RACK SHALL NOT ENCROACH ON ACCESSIBLE PEDESTRIAN ROUTES.
 2. THE WALLS MAY OR MAY NOT BE PRESENT ON BOTH SIDES OF BIKE RACK INSTALLATIONS. USE MINIMUM DISTANCES TO ANY PHYSICAL OBSTRUCTION OR CURB THAT MAY BE PRESENT.

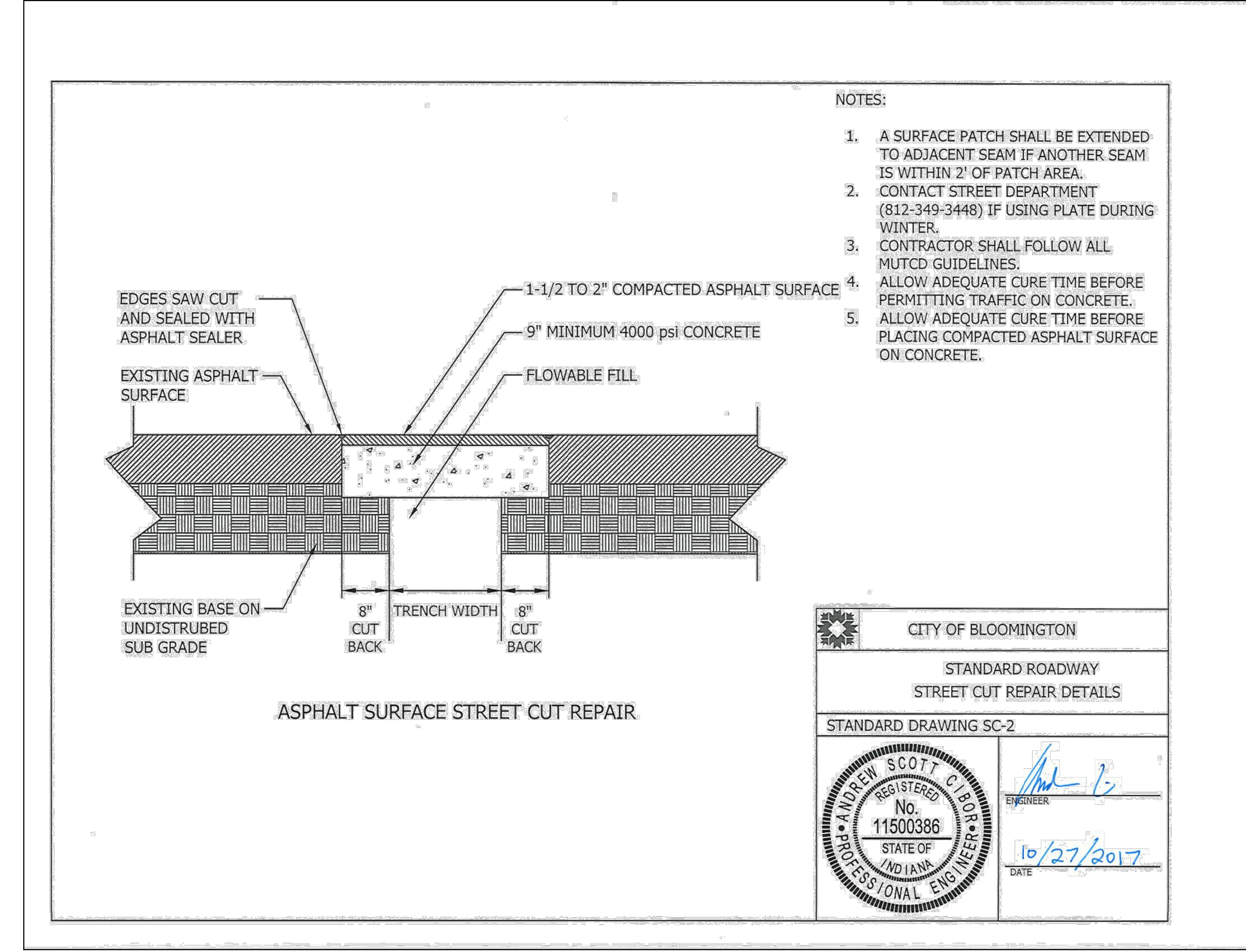

ASPHALT SURFACE STREET CUT REPAIR

- NOTES:**
1. A SURFACE PATCH SHALL BE EXTENDED TO ADJACENT SEAM IF ANOTHER SEAM IS WITHIN 2' OF PATCH AREA.
 2. CONTACT STREET DEPARTMENT (812-349-3448) IF USING PLATE DURING WINTER.
 3. CONTRACTOR SHALL FOLLOW ALL MUTCD GUIDELINES.
 4. ALLOW ADEQUATE CURE TIME BEFORE PERMITTING TRAFFIC ON CONCRETE.
 5. ALLOW ADEQUATE CURE TIME BEFORE PLACING COMPACTED ASPHALT SURFACE ON CONCRETE.

CITY OF BLOOMINGTON
STANDARD ROADWAY STREET CUT REPAIR DETAILS
STANDARD DRAWING SC-2

REGISTERED PROFESSIONAL ENGINEER
No. 11600386
STATE OF INDIANA
DATE: 10/27/2017

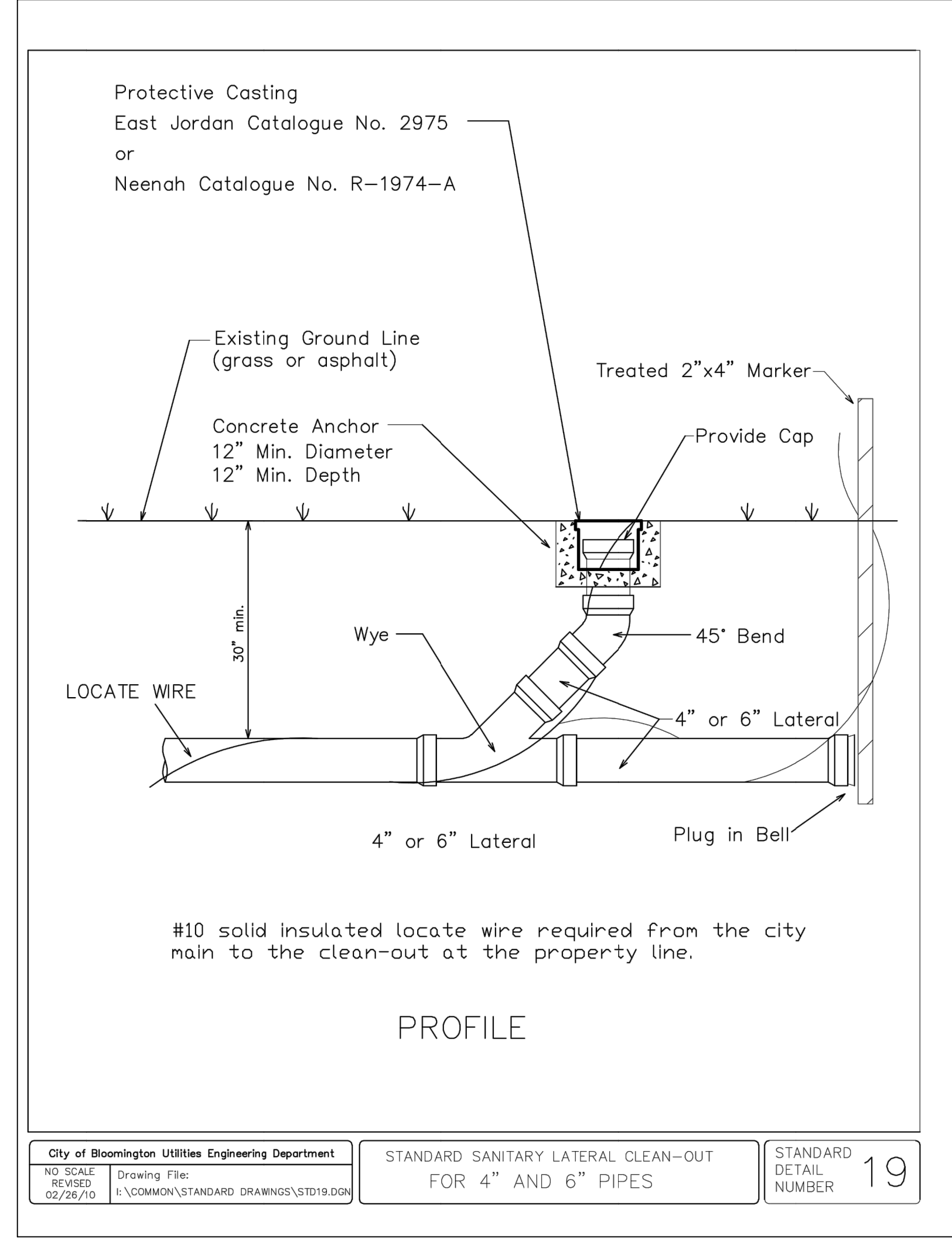

PROFILE

City of Bloomington Utilities Engineering Department
NO SCALE
REVISION: 02/26/10
Drawing File: I:\COMMON\STANDARD DRAWINGS\STD19.DWG

STANDARD SANITARY LATERAL CLEAN-OUT FOR 4" AND 6" PIPES

STANDARD DETAIL NUMBER 19

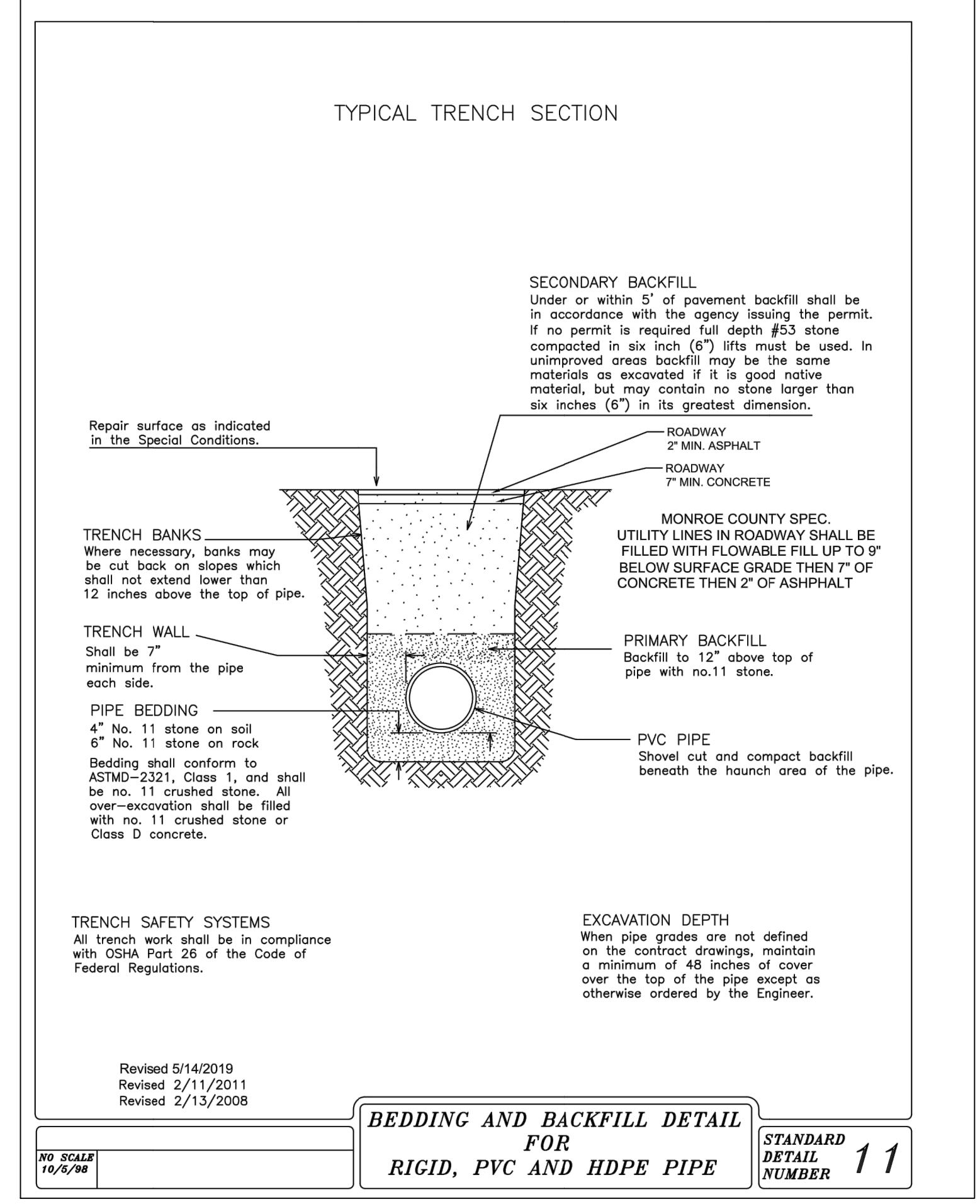

TYPICAL TRENCH SECTION

SECONDARY BACKFILL
Under or within 5' of pavement backfill shall be in accordance with the agency issuing the permit. If no permit is required full depth #53 stone compacted in six inch (6") lifts must be used. In unimproved areas backfill may be the same material as excavated if it is good native material, but may contain no stone larger than six inches (6") in its greatest dimension.

MONROE COUNTY SPEC.
UTILITY LINES IN ROADWAY SHALL BE FILLED WITH FLOWABLE FILL UP TO 9" BELOW SURFACE GRADE THEN 7" OF CONCRETE THEN 2" OF ASPHALT.

TRENCH SAFETY SYSTEMS
All trench work shall be in compliance with OSHA Part 26 of the Code of Federal Regulations.

EXCAVATION DEPTH
When pipe grades are not defined on the contract drawings, maintain a minimum of 48 inches of cover over the top of the pipe except as otherwise ordered by the Engineer.

BEDDING AND BACKFILL DETAIL FOR RIGID, PVC AND HDPE PIPE

NO SCALE
REVISION: 10/2/08

STANDARD DETAIL NUMBER 11

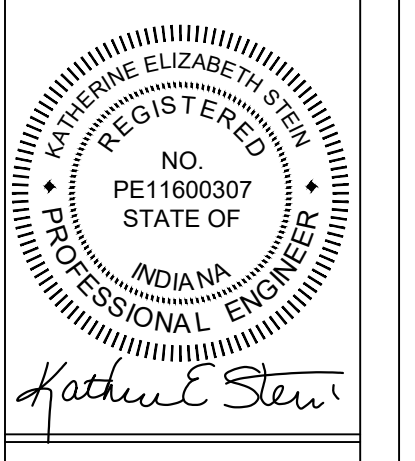
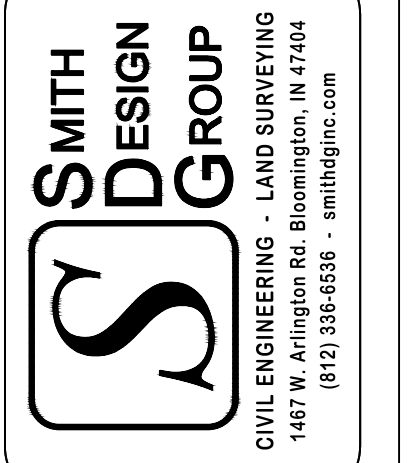

09/27/2022

**626 N. COLLEGE AVENUE
BLOOMINGTON, INDIANA**

BY	DATE	REVISIONS
DK	4/3/23	CBU REVISIONS
DK	5/04/23	CBU REVISIONS
DK	8/23/23	PLANNING AND CBU REVISIONS
DK	10/11/23	PLANNING AND CBU REVISIONS

JOB NUMBER
6396

SHEET
6 OF 7

DATE
10/11/2023

CIVIL DETAILS AND PROFILE

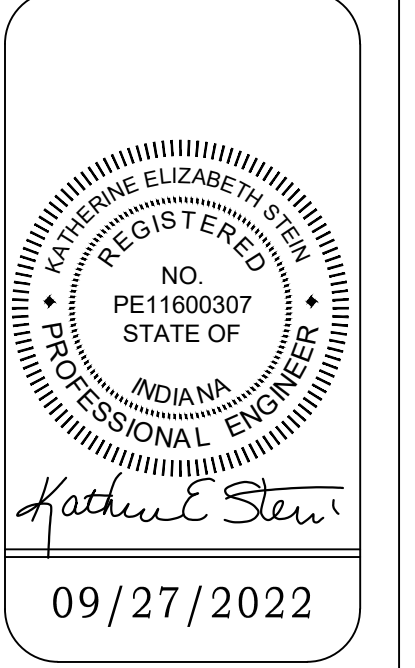
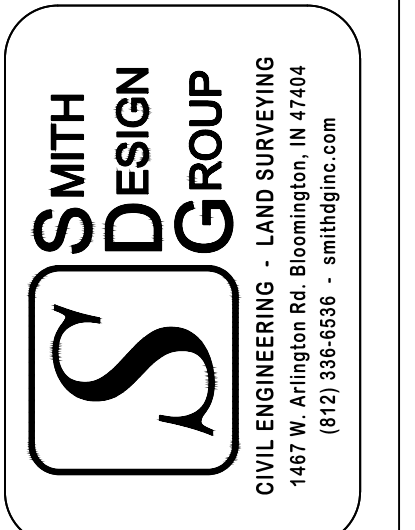
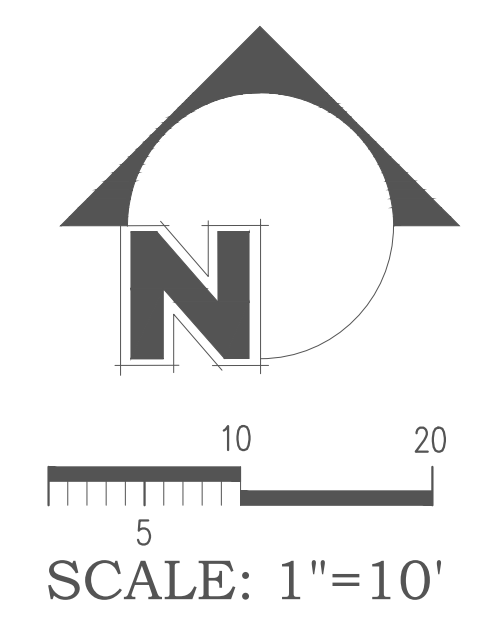
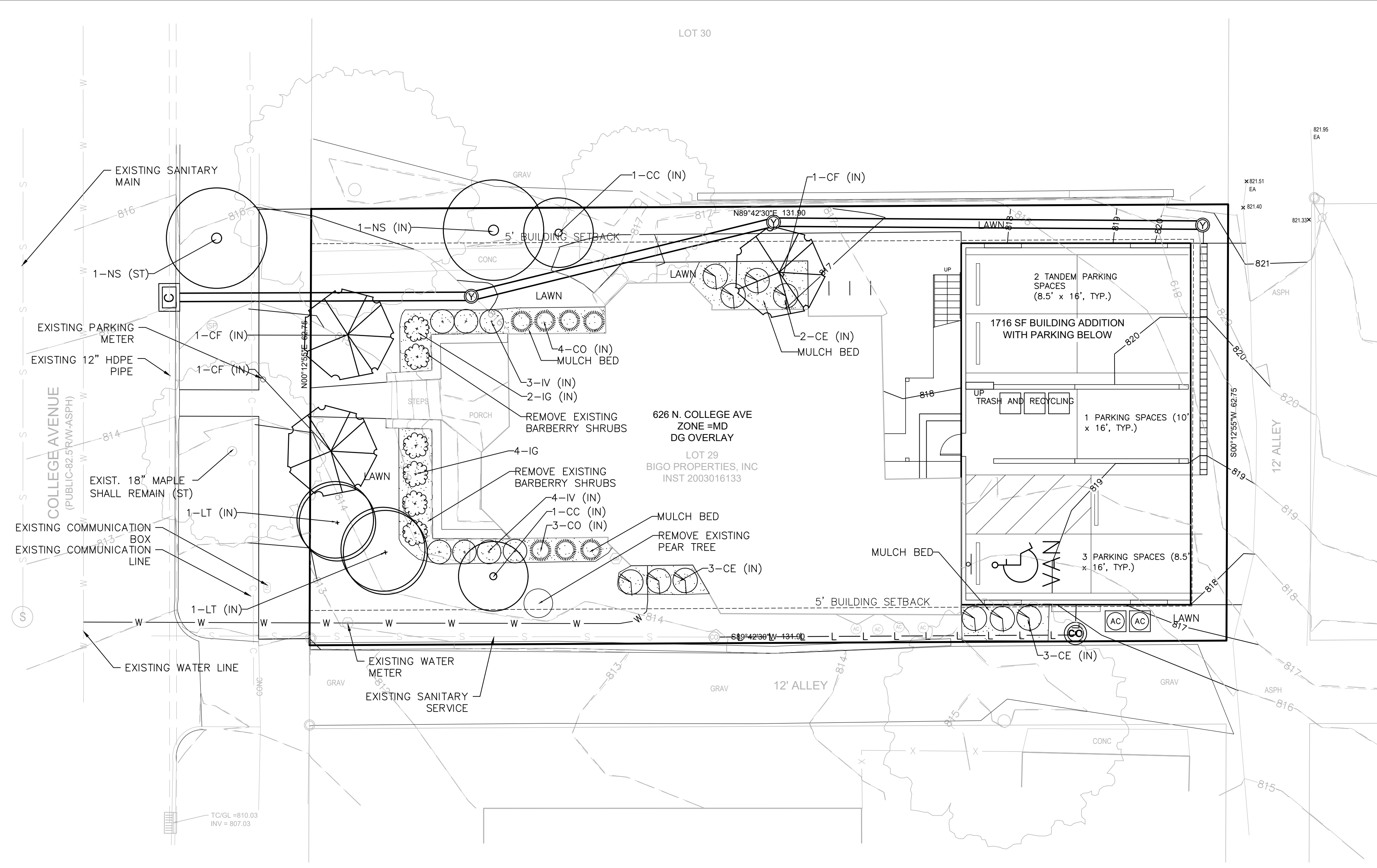

626 N. COLLEGE AVENUE
BLOOMINGTON, INDIANA

626 College Ave Multifamily
Zone=MD-DG Zone

Streetscape Landscape
1 tree per every 40 of right of way required.
College Ave R/W=63', 2 Trees required. 1-18" maple preserved; one new tree added. A small tree was used because of the proximity of other large trees.

Parking lot Perimeter:
All spaces are within the building

Interior plantings MD District
Total Site = 8276 SF
Building, sidewalk, and pavement area =5472 SF
Area not covered by building, sidewalk, and pavement=2804 SF
1 large canopy trees per 500 sf, and 8 shrubs per 500 sf Required
6 trees required and 45 shrubs required, 3 small trees were provided, and 1 large tree provided.
No other trees provided due to lack of space on the property.
24 shrubs provided. No other shrubs were provided due to lack of space.

LANDSCAPE NOTES

1. PLANT MATERIAL SUBSTITUTIONS MUST BE APPROVED IN WRITING BY CITY PLANNING PRIOR TO INSTALLATION.
2. ALL LANDSCAPED BEDS AND ISLANDS SHALL RECEIVE A MINIMUM OF 1" OF PLANTING MIX AND A MINIMUM OF 4" OF SHREDDED HARDWOOD BARK MULCH. BEDS SHALL HAVE A SPADE CUT EDGE.
3. THE PROPERTY OWNERS ARE RESPONSIBLE FOR MAINTAINING EXISTING AND NEW LANDSCAPING AS SHOWN ON THE APPROVED PLAN.

FINISH LAWN TYPE

FINISHED SEED MIXTURE shall be 50 lb/ac of Perennial Ryegrass, 50 lb/ac of Certified Common Kentucky Bluegrass, and 50 lb/ac of Kentucky Bluegrass or approved equivalent. Contractor shall seed at a rate of 150 lb/ac.

SOIL MIXTURE shall be 25% Compost
25% Sand and 50% Topsoil.

UDO LANDSCAPE CATEGORIES

INTERIOR PLANTING	IN
STREET TREE	ST

PLANT TABLE				
KEY	QTY	BOTANICAL NAME	COMMON NAME	SIZE
TREES				
CF	3	CORNUS florida	Flowering Dogwood	2" Caliper
CC	2	CERCIS canadensis	Redbud	2" Caliper
LT	2	LIRIODENDRON tulipifera	Tulip Tree	2" Caliper
NS	2	NYSSA sylvatica	Black Gum	
SHRUBS				
CO	7	CEPHALANTHUS occidentalis	Buttonbush	3 Gallon
CE	10	CEANOTHUS americanus	New Jersey Tea	3 Gallon
IG	6	ILEX glabra	Inkberry	3 Gallon
IV	7	ITEA virginica	Virginia Sweetspire	3 Gallon

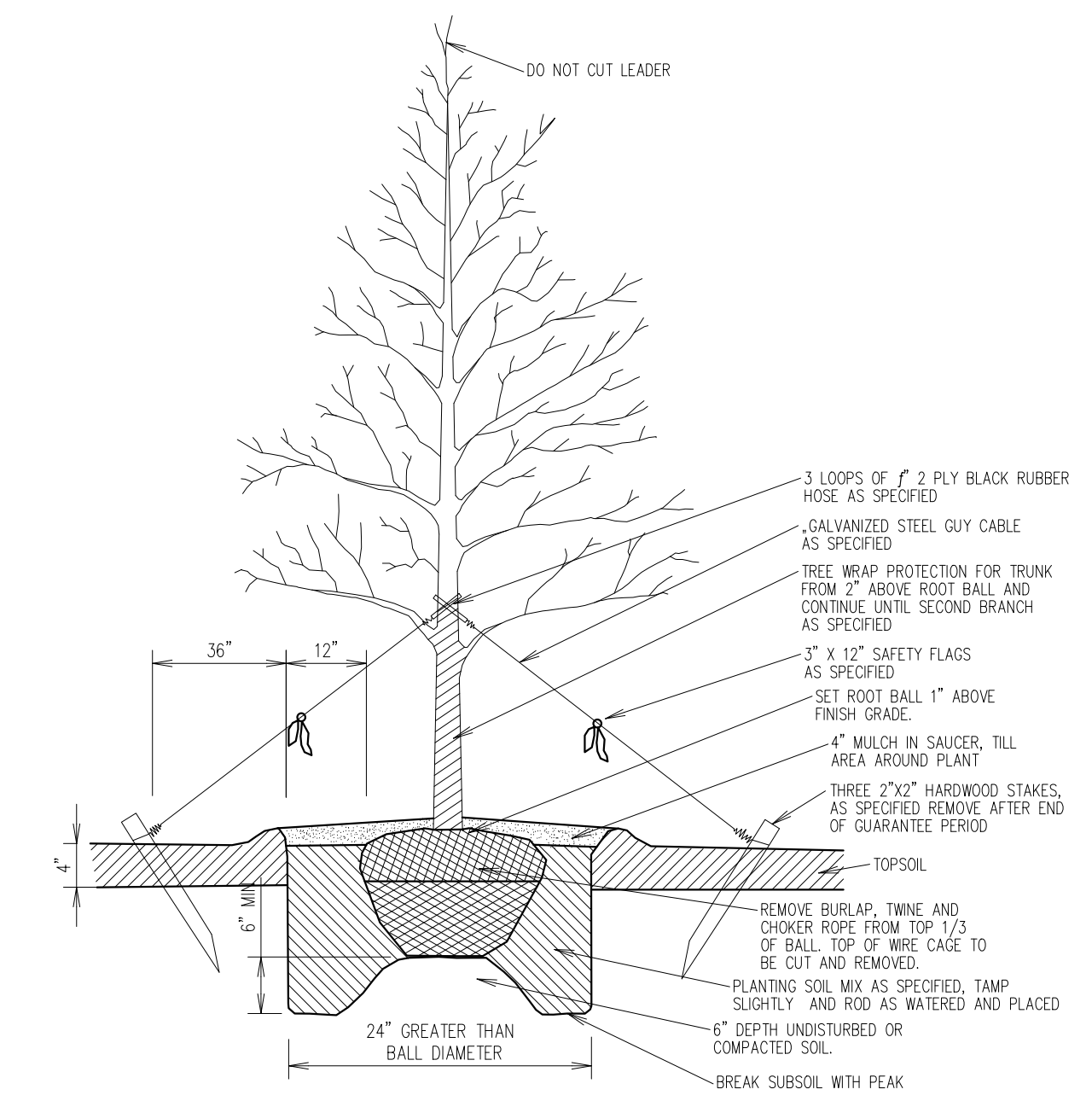

TREE PLANTING & GUYING DETAIL
NO SCALE

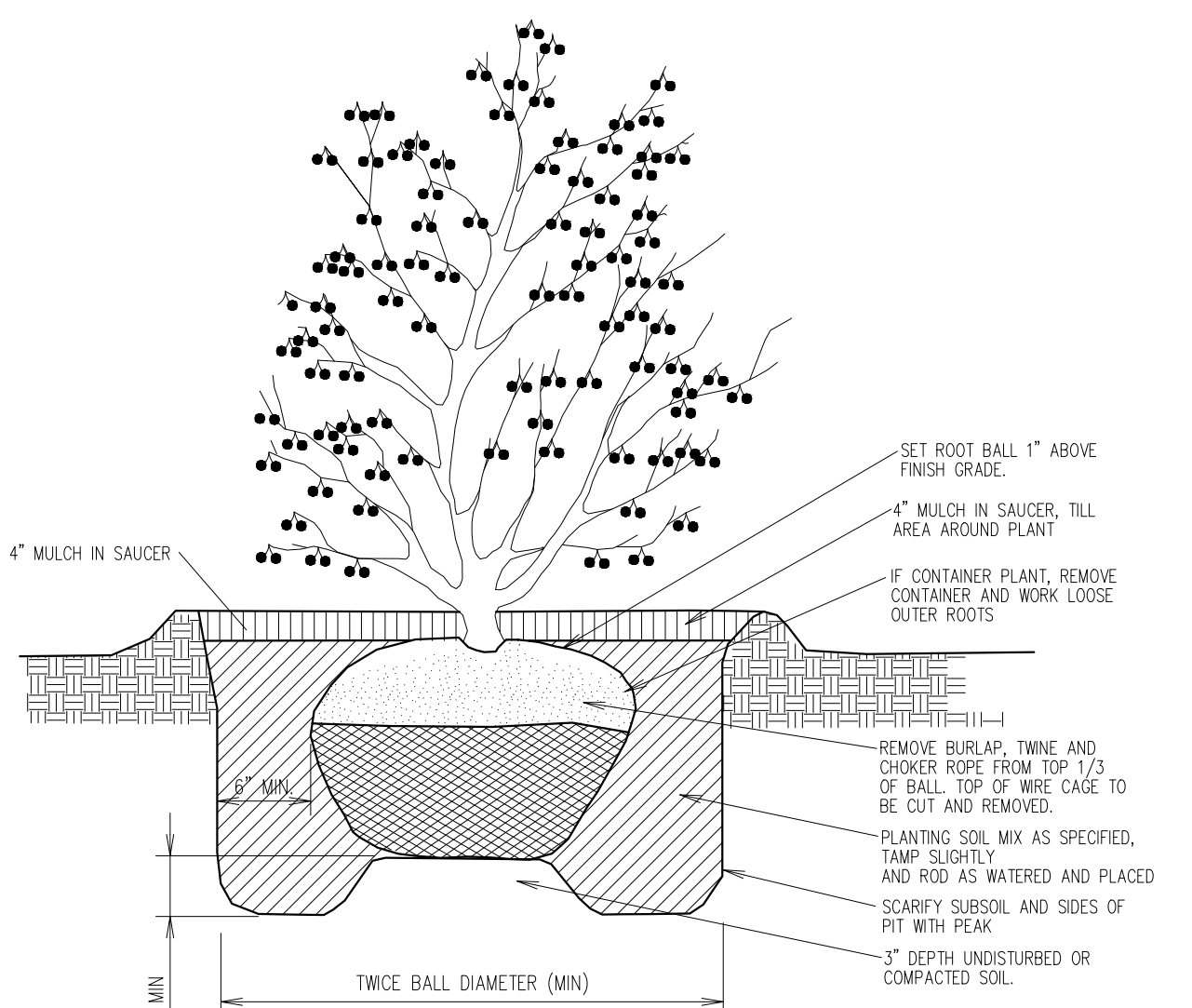

SHRUB PLANTING DETAIL
NO SCALE

REVISIONS	BY	DATE
CBU REVISIONS	DK	4/3/23
CBU REVISIONS	DK	5/04/23
PLANNING AND CBU REVISIONS	DK	8/23/23
PLANNING AND CBU REVISIONS	DK	10/11/23

DISBURSED	DATE
DK	
WDW	
CHECKED	

JOB NUMBER
6396

SHEET
7 OF 7

DATE
10/11/2023

LANDSCAPE PLAN

REGISTER OF PAYROLL CLAIMS
Board: Board of Public Works Claim Register

Date:	Type of Claim	FUND	Description	Bank Transfer	Amount
5/3/2024	Payroll				587,821.09
					<u>587,821.09</u>

ALLOWANCE OF CLAIMS

We have examined the claims listed on the foregoing register of claims, consisting of 1
claim, and except for the claims not allowed as shown on the register, such claims are hereby allowed in the
total amount of \$ 587,821.09

Dated this 6th day of May year of 2024.

Kyla Cox Deckard, President Elizabeth Karon, Vice President James Roach, Secretary

I hereby certify that each of the above listed voucher(s) or bill(s) is (are) true and correct and I have audited same in accordance with IC 5-11-10-1.6.

Fiscal Officer _____



Board of Public Works Staff Report

Project/Event: Approve Change Order Package #1 for the 1st Street Reconstruction Project

Petitioner/Representative: Engineering Department

Staff Representative: Zac Rogers

Date: May 6th, 2024

- **Report:** On December 13th 2023 this project was awarded by INDOT to Milestone Contractors LLC in the amount of \$6,247,803.72. This package of change orders include the following change orders totaling an addition of \$5,362.41 to the contract, for a final contract amount of \$6,253,166.13
 - CO #1, Time Extension, +\$0 - The time extension (additional 2 working days) is due to the Eclipse as INDOT's Memo 24-04
 - CO #2, Additional MOT, +\$5,362.41 – Additional MOT for a Lane Closure on College Ave at 1st Street was left off the plan set. The additional MOT is required to install a new storm system and traffic signals.

City of Bloomington Contract and Purchase Justification Form

Vendor: Milestone Contractors, LLC

Contract Amount: \$6,253,166.13

This form should be completed and attached to the contract documents and forwarded to the Legal Department Attorney assigned to your Department. Contracts will not be approved by the Controller if a completed form is not included with the contract documents.

PURCHASE INFORMATION

1. Check the box beside the procurement method used to initiate this procurement: (Attach a quote or bid tabulation if applicable)

<input type="checkbox"/> Request for Quote (RFQ)	<input type="checkbox"/> Request for Proposal (RFP)	<input type="checkbox"/> Sole Source	<input checked="" type="checkbox"/> Not Applicable (NA)
<input type="checkbox"/> Invitation to Bid (ITB)	<input type="checkbox"/> Request for Qualifications (RFQu)	<input type="checkbox"/> Emergency Purchase	

2. List the results of procurement process. Give further explanation where requested.

	Yes	No		Yes	No
# of Submittals: 1			Was the lowest cost selected? (If no, please state below why it was not.)	<input checked="" type="checkbox"/>	<input type="checkbox"/>
Met city requirements?	<input checked="" type="checkbox"/>	<input type="checkbox"/>			
Met item or need requirements?	<input checked="" type="checkbox"/>	<input type="checkbox"/>			
Was an evaluation team used?	<input type="checkbox"/>	<input checked="" type="checkbox"/>			
Was scoring grid used?	<input type="checkbox"/>	<input checked="" type="checkbox"/>			
Were vendor presentations requested?	<input type="checkbox"/>	<input checked="" type="checkbox"/>			

3. State why this vendor was selected to receive the award and contract:

Construction project awarded to Milestone Contractors on December 13th by INDOT. Change Orders are being processed in compliance with the contract documents.

Original	\$6,247,803.72
Change Order #1	\$0
Change Order #2	\$5,362.41
Final	\$6,253,166.13

Zac Rogers

Print/Type Name

Project Manager

Print/Type Title

Engineering

Department

INDIANA Department of Transportation
Construction Change Order and Time Extension Summary

Contract Information

District:SEYMOUR DISTRICT

Contract No.: R -41892

AE:Wren, Rachel

Letting Date:12/13/2023

PE/S:Decker, Lawrence

Status:Pending

Change Order Information

Date Generated: 03/12/2024

Change Order No.: 001

Date Approved: 00/00/0000

EWA: N or Force Acct: N

Reason Code: STANDARDS/SPECS CHANGE, Time Related

Description: Time Adjustment for Solar Eclipse

Original Contract Amount

\$ 6,247,803.72

Current Change Order Amount

\$ 0.00

Percent: 0.000 %

Total Previous Approved Changes

\$ 0.00

Percent: 0.000 %

Total Change To-Date

\$ 0.00

Percent: 0.000 %

Modified Contract Amount

\$ 6,247,803.72

Time Extension Information

Date Initiated 03/12/2024

Date Completed 03/15/2024

Original Contract Time

SS Completion Date 05/31/2025 or SS Calendar/Work Days 0

SP Date 00/00/0000

or SP Days

(SS = Standard Specification, SP = Special Provision)

Time Element Description: This time extension is generated as per INDOT Memorandum 24-04 for the Solar Eclipse on April 8, 2024. The Contractor will be shut down from Sunday April 7, 2024 at 12:00am until Sunrise on Tuesday April 9, 2024 at sunrise.

Current Time Extension

SS Days 0 SP Days 2

SP Days Value \$ 0.00

Previous Time Approved

SS Days by AE: _____ DCE: _____ SCE: _____ DDCM: _____

SS Days _____

SP Days Value \$ _____

Revised Contract Time

SS Completion Date 00/00/0000 or SS Calendar/Work Days 0

SS Date 00/00/0000

or SP Days 0

**INDIANA Department of Transportation
Construction Change Order and Time Extension Summary**

Review and Approval Information

Required Approval Authority AE: _____ DCE: _____ SCE: _____ * DDCM: _____ *
(\$ per Change Order) (- LE \$ 250K-) (- LE \$ 750K -) (-- LE \$ 2 M --) (-- GT \$ 2 M --)
(Days per Contract) (50 SS days) (100 SS days) (200 SS Days) (GT 200 SS days)

Verbal Approval Required? Y / N If Y, by _____ Date Issued _____

Total Change To-Date>5%? Y / N If Y , Copy to Program Budget Manager _____

Scope/Design Recommendation Y / N If Y, Referred to Project Manager(PM) _____
Required? Date to PM _____ Date Returned _____

Approval Authority Concurs with PM? Y / N If Y, Concurrence by _____ Date _____
If N,Resolution: Approved _____ Disapproved _____
Resolved by _____ Date _____

LPA Signatures Required? Y / N If Y, Date to LPA _____ Date Returned _____

FHWA Signatures Required? Y / N If Y, Date to FHWA _____ Date Returned _____

* Field Engineer Recommendation (Required for SCE or DDCM Approval)

Field Engineer _____ Date _____

Comments: _____

Contract No:R -41892
Change Order No:001

INDIANA
Department of Transportation

Date:04/15/2024
Page: 3

Contract: R -41892
Project: State:1900399
Change Order Nbr: 001
Change Order Description: Time Adjustment for Solar Eclipse
Reason Code: STANDARDS/SPECS CHANGE, Time Related

CLN	PCN	PLN	Item Code	Unit	Unit Price	CO Qty	Comment	Amount Change
-----	-----	-----	-----------	------	------------	--------	---------	---------------

Total Value for Change Order 001 = \$ 0.00

Contract Completion Date Time Adjustment

Original Completion dt: 05/31/2025 Adj compl dt 06/02/2025 Adj No. of Days 2

Explanation: This time extension is generated as per INDOT Memorandum 24-04 for the Solar Eclipse on April 8, 2024. The Contractor will be shut down from Sunday April 7, 2024 at 12:00am until Sunrise on Tuesday April 9, 2024 at sunrise.

Milestone Time Adjustment

MileStone Nbr: 04

Milestone Description: INTERMEDIATE COMPLETION DATE 1, PHASE 2

Original Completion dt: 07/31/2024 Adj compl dt 08/02/2024 Adj No. of Days 2

Explanation: This time extension is generated as per INDOT Memorandum 24-04 for the Solar Eclipse on April 8, 2024. The Contractor will be shut down from Sunday April 7, 2024 at 12:00am until Sunrise on Tuesday April 9, 2024 at sunrise.

Milestone Time Adjustment

MileStone Nbr: 05

Milestone Description: INTERMEDIATE COMPLETION DATE 2: ALL WORK EXCEPT PLANTINGS

Original Completion dt: 10/31/2024 Adj compl dt 11/02/2024 Adj No. of Days 2

Explanation: This time extension is generated as per INDOT Memorandum 24-04 for the Solar Eclipse on April 8, 2024. The Contractor will be shut down from Sunday April 7, 2024 at 12:00am until Sunrise on Tuesday April 9, 2024 at sunrise.

Whereas, the Standard Specifications for this contract provides for such work to be performed, the following change is recommended.

General or Standard Change Order Explanation

This time extension is generated as per INDOT Memorandum 24-04 for the Solar Eclipse on April 8, 2024. The Contractor will be shut down from Sunday April 7, 2024 at 12:00am until Sunrise on Tuesday April 9, 2024 at sunrise. A time adjustment is required for this change and has been addressed herein.

Change Order Explanation for Specific Line Item

It is the intent of the parties that this change order is full and complete compensation for the work describe above.
Notification and consent to this change order is hereby acknowledged.

Contractor: _____

Signed By: _____

Date: _____

NOTE: Other required State and FHWA signatures will be obtained electronically through the SiteManager system.

APPROVED FOR LOCAL PUBLIC AGENCY

(SIGNATURE)

(TITLE)

(DATE)

(SIGNATURE)

(TITLE)

(DATE)

SUBMITTED FOR CONSIDERATION

PE/S _____

APPROVED FOR INDIANA DEPARTMENT OF TRANSPORTATION

Approval Level	Name of Approver	Date	Status
Project Engineer/Supervisor	Decker, Lawrence	00/00/0000	Action Pending



INDIANA DEPARTMENT OF TRANSPORTATION

100 North Senate Avenue
Room N758-CM
Indianapolis, Indiana 46204

www.in.gov/indot/

Eric Holcomb, Governor
Michael Smith, Commissioner

March 5, 2024

CONSTRUCTION MEMORANDUM 24-04

TO: District Deputy Commissioners
District Construction Directors
District Area Engineers
District Project Engineers/Supervisors/Managers
District Testing Engineers

FROM: Gregory G. Pankow, P.E., Chief Engineer of Construction
Division of Construction Management and District Support

SUBJECT: Total Solar Eclipse 2024

The Total Solar Eclipse 2024 will begin at approximately 1:45 p.m. Eastern time on Monday April 8, 2024, and end at about 4:30 p.m. Eastern time that same day. During this time, the sun will be partially obscured by the moon, and you should use special eclipse sunglasses to view the eclipse without risking permanent eye damage.

Totality is the most special stage of the eclipse and is the only period of time when you can observe the total eclipse without eclipse glasses. This stage will begin at roughly 3 p.m. Eastern in the southwestern part of the state and will be over within just a few minutes. The exact duration depends on the location. Regardless of where you are in Indiana, by 3:15 p.m. Eastern time, totality will be finished everywhere in the state.

Because of the Total Solar Eclipse, Contractors shall not work during the time frame shown below, unless prior written approval is received from the Engineer. All deliveries and traffic coming from suppliers shall cease during the Department-ordered suspension of work listed below. Time extensions to closure periods, intermediate completion dates, or contract completion dates will be granted for suspending work during the eclipse weekend period. If a Contractor request to continue working is approved by the Engineer and the Contractor works during the time frame below, no days will be added to the contract.

Work shall be suspended from 12:00 am Sunday April 7, 2024, until sunrise on Tuesday April 9, 2024. If this contract suspension is not stated in the contract documents, the contract completion times will be adjusted as per 108.08.

GGP

CHANGE ORDER REQUEST FORM

CONTRACT NO. **R-41892** DATE OF SUBMISSION **May 3, 2024**

PROJECT DESCRIPTION <i>(route / intersection / bridge no(s).)</i>	ADDED LANE CLOSURES COLLEGE AND 1 ST STREET
CHANGE ORDER REQUEST SUMMARY DESCRIPTION	ADDED COST FOR ADDITIONAL MOT
PROPOSED SOLUTION SUMMARY	Click here to enter text.

NOTE: Upon request from Engineer, enter detailed description on page 2.

ONSET DATE OF CHANGE	March 22, 2024	CHANGE ORDER TYPE	104.03 Extra Work
-----------------------------	-----------------------	--------------------------	-------------------

PROPOSED COST AND TIME ADJUSTMENT

COST

COST INCREASE / (DECREASE):

\$

5362.41

The cost adjustment shall include lump sum and/or estimated totaled unit-priced item costs. Attach a separate sheet of unit price items including item description, unit of measurement, estimated quantity and unit price.

CHECK APPROPRIATE BOXES PER APPROPRIATE BASIS OF COST CHANGE:

109.03 Altered Quantities 109.05(a) Agreed Price 109.05(b) Force Account 109.05.02 Delay Costs

PROPOSED COST CHANGE INCLUDES: Labor Material Equipment Lease Agreement Subcontractor

TIME ADJUSTMENT

INCREASE / (DECREASE):

(work days)

Click here to enter text.

CHECK APPROPRIATE BOXES PER APPROPRIATE BASIS OF TIME CHANGE:

108.08(a) Excusable, Non-Compensable 108.08(b) Excusable, Compensable

NOTE: If **Compensable**, attach details based on 109.05.2(a) Allowable Delay Costs.

SUPPLEMENTAL INFORMATION

Additional information.

CHANGE ORDER ORIGATION:	<input checked="" type="checkbox"/> INDOT / LPA	<input type="checkbox"/> Contractor
DOCUMENTS AFFECTED:		
<input type="checkbox"/> Contract Specifications (ref. doc name/no.)	Click here to enter text.	
<input type="checkbox"/> Contract Plans (ref. doc name/no.)	Click here to enter text.	
CHANGE ORDER AFFECTS DBE PARTICIPATION:	<input type="checkbox"/> yes <input checked="" type="checkbox"/> no (if yes, attach details)	

CONTRACT NO.**R-41892****UPON WRITTEN REQUEST FROM THE ENGINEER, PROVIDE ADDITIONAL DETAIL**

DATE RECEIVED REQUEST FOR ADDITIONAL DETAIL	[Select Date]	SUBMITTAL DATE OF ADDITIONAL DETAIL	[Select Date]
--	---------------	--	---------------

DETAILED DESCRIPTION / JUSTIFICATION:

(Include location(s), actions of contractor, owner, and other stakeholders, key events and related cause(s), discoveries, discussions, meetings, and effect on the contract if no action is taken. Also include references to key documents attached or available to support this change order request.)

THERE WAS NO MOT IN DESIGN FOR COLLEGE INTERSECTION WORK FOR PHASE 1

PROPOSED SOLUTION – ADDITIONAL DETAILS:

(Include proposed scope of work, means & methods, materials, equipment, utility relocation required, subcontracted scope and the effect on the contract schedule. Also include references to attached documents including, but not limited to, sketches, calculations, photos, material information, and submittals and meeting minutes.)

Click here to enter text.

SIGNATURE

Contractor:

Name: (print) THOMAS GOTT _____

(signature) THOMAS GOTT _____ Date: 5/8/2023

THOMAS GOTT _____

NOTE: The Contractor should retain a signed copy of this document for record.

CONTRACT NO.

R-41892

ATTACHMENT: UNIT PRICE ITEMS DETAIL

Attach or paste a unit price item detail.



Milestone Contractors, L.P.
 4755 West Arlington Rd.
 Bloomington, IN 47404
 Phone: (812) 330-2037
 Fax: (812) 330-2118

PCO Pricing Sheet

Date: May 3, 2024

www.milestonelp.com

Pages: 4

To: City of Bloomington
 LARRY DECKER HWC ENGINEERING
 ROY ATEN CITY OF BLOOMINGTON

Project: R-41892 1ST STREET RECONSTRUCTION

Description: ADDITIONAL MOT COLLEGE

Est. No.

Ref: MOT

Qty: 1 LS

Labor:

Total Labor Cost from Estimate Sheet:

Labor Subtotal

Equipment:

Total Equipment Cost from Estimate Sheet:

Equipment Subtotal

Material:

Total Material Cost from Estimate Sheet:

Material Subtotal

Subcontractors:

Total Subcontractor cost from Attached Sheets:

Subcontractor Subtotal \$ 5,067.25

Subtotal \$ 5,067.25

Bond (.75% rate) 10% \$ 41.80

Labor Markup 10%

Equipment Markup 10% \$ -

Material Markup 10% \$ -

Subcontractor Markup 5% \$ 253.36

Total \$ 5,362.41

Per LS

Unit Price \$ 5,362.41

ANY ITEM NOT SPECIFICALLY STATED ABOVE SHALL BE CONSIDERED NOT INCLUDED IN OUR PROPOSAL.

PLEASE CALL FOR CLARIFICATIONS OR IF ADDITIONAL PRICING IS REQUESTED.

Signature represents acceptance of this Proposal.

Signed: Tommy Gott

Date: April 29, 2024

Terms: Upon Receipt

Submitted By: Tommy Gott

Approved By: _____ Date

Printed: _____ Date



Indiana Sign & Barricade, Inc.
is a Certified DBE/WBE

5240 E. 25th Street
Indianapolis, IN 46218
317-377-8000
317-377-8008
www.IndianaSB.com

Change Order #1

Contract No: R-41892-B
Customer Name: Milestone LP
Contact Name: Thomas Gott
ISB Job No: 24-039
Letting Date: December 13, 2024
Completion Date: May 31, 2025

Submitted by: Colin O'Keefe
Cell Phone: 317-292-3618
cokeefe@IndianaSB.com

Table with 7 columns: ITEM #, INDOT Item, DESCRIPTION, QUANTITY, UNIT, UNIT PRICE, EXTENSION. Rows include Construction Sign A, MOT - Partial - See Note 4, and a Total row.

- NOTES: 4) Item EWA1-1, Maintaining Traffic (Partial) includes:
a) Drums as shown on Plan Sheets 1 thru 2 Calendar Days. Price includes initial installation and final removal. Daily closing and opening of lanes by others. Daily Maintenance and/or daily relocation is NOT the responsibility of ISB.
b) Does not include Movement/Relocation of Lane Closure Equipment.
c) Does not include Flashing Arrow Sign. Milestone to provide Flashin Arrow Sign.

Amy L. Zakutansky
Amy L. Zakutansky, President

Date: March 13, 2024

Accepted: THOMAS GOTT
Printed Name:
Company Name: MILESTONE CONTRACTORS

Date: 4/26/24

Indiana Sign and Barricade, Inc.
Job Estimate Worksheet

	A	B	C	D	E	F	G	H	I	J	K
1	Contract No:	R-41892			Letting Date:		December 13, 2024			Distance to job	
2	Location: W 1st St & S College Ave, Bloomington				Completion Date:		May 31, 2025			in hrs:	1.25
3											
4	Calendar Days:	2			Equipment Loss %:		10				
5											
6	Device	Quantity	Add Loss	Purchase	Cost/Day	Rent	Sell	Job Cost	A sign	B sign	C sign
7											
8	Drum Diamond Grade	16	17.60	70.68	0.1448	5.10	1243.97	5.10			
9	Drum Hi-intensity		0.00	49.22	0.1009	0.00	0.00	0.00			
10	Tubular Markers		0.00	35.73	XXX	XXX	0.00	0.00			
11											
12											
13	A light		0.00	19.59	0.0268	0.00	0.00	0.00	0		0
14	B light		0.00	55.24	0.0755	0.00	0.00	0.00			
15	C light	6	6.60	19.59	0.0268	0.35	129.29	0.35			
16	Batteries	1	1.29	0.75	XXX	XXX	0.97	0.97	0		0
17											
18	Arrowboard		0.00	4200	4.67	0.00	0.00	0.00			
19	Messageboard		0.00	16000	8.89	0.00	0.00	0.00			
20	TWSSA		0.00	4800	5.33	0.00	0.00	0.00			
21											
22	12' III-A barricade		0.00	247.41	0.3380	0.00	0.00	0.00			
23	12' III-B barricade		0.00	333.69	0.4559	0.00	0.00	0.00			
24	R11-2		0.00	112.25	0.1533	0.00	0.00	0.00			
25	R11-3 or R11-4		0.00	101.25	0.1383	0.00	0.00	0.00			
26	4' x 4' Signs		0.00	108.00	0.1475	0.00	0.00	0.00	0		
27	End Construction		0.00	67.50	0.0922	0.00	0.00	0.00	0		
28	Construction Sign, B		0.00	45.00	0.0615	0.00	0.00	0.00		0	
29	Construction Sign, C		0.00	108.00	0.1475	0.00	0.00	0.00			0
30	Construction Sign, D		0.00	45.00	0.0615	0.00	0.00	0.00			
31	Detour Route Marker		0.00	75.00	0.1025	0.00	0.00	0.00			
32	UNITS	0									
33	Sandbags		0.00	5.00	XXX	XXX	0.00	0.00			
34	Portable Sign Stand		0.00	61.00	0.0500	0.00	0.00	0.00			
35	8' green post		0.00	20.80	0.0170	0.00	0.00	0.00	0	0	0
36	10' green post		0.00	26.00	0.0213	0.00	0.00	0.00			
37	12' green post		0.00	31.20	0.0256	0.00	0.00	0.00	0	0	0
38	7' Delineator Post		0.00	35.00	0.0287	0.00	0.00	0.00			
39											
40	Total Job Equipment Costs =							6.42	0	0	0
41											
42									A sign	B sign	C sign

Indiana Sign and Barricade, Inc.
Job Estimate Worksheet

	A	B	C	D	E	F	G	H	I	J	K
43	Employee	RT Hrs	RT Rate	RT Amt.	OT Hrs	OT Rate	OT Amt.	Total	COMMENTS		
44											
45	INSTALLATION								A sign	B sign	C sign
46	Foreman	0.00	60.38	0.00	0.00	81.75	0.00	0.00	0	0	0
47	Operator	1.50	58.38	87.57	0.50	78.75	39.38	126.95	0	0	0
48	Laborer	1.50	46.39	69.59	0.50	60.77	30.38	99.97	0	0	0
49											
50	REMOVAL										
51	Foreman	0.00	60.38	0.00	0.00	81.75	0.00	0.00	0	0	0
52	Operator	1.50	58.38	87.57	0.50	78.75	39.38	126.95	0	0	0
53	Laborer	1.50	46.39	69.59	0.50	60.77	30.38	99.97	0	0	0
54											
55	MAINTENANCE										
56	Foreman	0.00	60.38	0.00	0.00	81.75	0.00	0.00			
57	Operator	0.00	58.38	0.00	0.00	78.75	0.00	0.00	0		0
58	Laborer	0.00	46.39	0.00	0.00	60.77	0.00	0.00			
59											
60	Traffic Control Plan										
61	Foreman	0.00	60.38	0.00	0.00	81.75	0.00	0.00			
62	Operator	1.50	58.38	87.57	0.50	78.75	39.38	126.95			
63	Laborer	0.00	46.39	0.00	0.00	60.77	0.00	0.00			
64											
65	DRIVE & SHOP TIME										
66	Install trips	1									
67	Operator	5.25	58.38	306.50	1.75	78.75	137.81	444.31	0	0	0
68	Laborer	5.25	46.39	243.55	1.75	60.77	106.34	349.89	0	0	0
69											
70					Total Job Labor Costs =			1,374.96	0.00	0.00	0.00
71					Total Drive/Shop Labor Costs =			794.19			
72	TRUCKS				Total On Site Labor Costs =			580.77			
73	Driver	13.00	\$48.77								
74											
75					Total Job Truck Costs =			634.02	0.00	0.00	0.00
76											
77					20% labor markup =			274.99	0.00	0.00	0.00
78					12% equipment markup =			0.77	0.00	0.00	0.00
79					12% truck markup =			76.08	0.00	0.00	0.00
80					Totals =			2367.245	0.00	0.00	0.00



Date: 3/13/2024 Author: Colin O'Keefe Project: Single Lane Closure Bloomington
Comments:
Non-Engineer Stamped Plans

**INDIANA Department of Transportation
Construction Change Order and Time Extension Summary**

Contract Information

District:SEYMOUR DISTRICT

Contract No.: R -41892

AE:Wren, Rachel

Letting Date:12/13/2023

PE/S:Decker, Lawrence

Status:Pending

Change Order Information

Date Generated: 03/15/2024

Change Order No.: 002

Date Approved: 00/00/0000

EWA: Y or Force Acct: N

Reason Code: ERRORS & OMISSIONS, Traf Cont Related

Description: Additional MOT for Lane Closure on College St. at 1st Street

Original Contract Amount \$ 6,247,803.72

Current Change Order Amount \$ 5,362.41

Percent: 0.086 %

Total Previous Approved Changes \$ 0.00

Percent: 0.000 %

Total Change To-Date \$ 5,362.41

Percent: 0.086 %

Modified Contract Amount \$ 6,253,166.13

Time Extension Information

Date Initiated 00/00/0000

Date Completed 00/00/0000

Original Contract Time

SS Completion Date 00/00/0000 or SS Calendar/Work Days 0

SP Date 00/00/0000 or SP Days

(SS = Standard Specification, SP = Special Provision)

Time Element Description:

Current Time Extension

SS Days 0 SP Days 0 SP Days Value \$ 0.00

Previous Time Approved

SS Days by AE:_____ DCE:_____ SCE:_____ DDCM:_____

SS Days_____ SP Days Value \$ _____

Revised Contract Time

SS Completion Date 00/00/0000 or SS Calendar/Work Days 0

SS Date 00/00/0000 or SP Days 0

**INDIANA Department of Transportation
Construction Change Order and Time Extension Summary**

Review and Approval Information

Required Approval Authority AE:_____ DCE:_____ SCE:_____ * DDCM:_____ *
(\$ per Change Order) (- LE \$ 250K-) (- LE \$ 750K -) (-- LE \$ 2 M --) (-- GT \$ 2 M --)
(Days per Contract) (50 SS days) (100 SS days) (200 SS Days) (GT 200 SS days)

Verbal Approval Required? Y / N If Y, by_____ Date Issued_____

Total Change To-Date>5%? Y / N If Y , Copy to Program Budget Manager_____

Scope/Design Recommendation Y / N If Y, Referred to Project Manager(PM) _____
Required? Date to PM_____ Date Returned_____

Approval Authority Concurs with PM? Y / N If Y, Concurrence by_____ Date_____
If N,Resolution: Approved _____ Disapproved _____
Resolved by_____ Date_____

LPA Signatures Required? Y / N If Y, Date to LPA _____ Date Returned _____

FHWA Signatures Required? Y / N If Y, Date to FHWA_____ Date Returned_____

* Field Engineer Recommendation (Required for SCE or DDCM Approval)

Field Engineer _____ Date _____

Comments: _____

Contract: R -41892
Project: 1900399 - State:1900399
Change Order Nbr: 002
Change Order Description: Additional MOT for Lane Closure on College St. at 1st Street
Reason Code: ERRORS & OMISSIONS, Traf Cont Related

CLN	PCN	PLN	Item Code	Unit	Unit Price	CO Qty	Comment	Amount Change
0116	1900399	0116	801-06640	EACH	450.000	6.000	C	Amount:\$ 2,700.00
Item Description: CONSTRUCTION SIGN, TYPE A								
Supplemental Description1:								
Supplemental Description2:								
0162	1900399	0163	801-06775	LS	2,662.410	1.000	C	Amount:\$ 2,662.41
Item Description: MAINTAINING TRAFFIC								
Supplemental Description1:								
Supplemental Description2: Additional Maintaing Traffic for Lane Closure on College St.								

Total Value for Change Order 002 = \$ 5,362.41

Whereas, the Standard Specifications for this contract provides for such work to be performed, the following change is recommended.

General or Standard Change Order Explanation

A contract time adjustment is not required for this change.

General or Standard Change Order Explanation

Additional MOT required for lane closures on College St.at first street in Bloomington. The MOT for the lane closures on College Street was left off the plans and is needed to place Pipes across College at the intersection of 1st Street. A contract time adjustment is not required for this change. Due to the insufficient bid history data for the Maintaining Traffic item added as part of this change order, HWC and the City of Bloomington have reviewed the details of this item cost provided by Milestone, including materials/equipment/labor for the installation, removal, and delivery of drums with type c lights, and determined it to be acceptable based on the manner of work being performed. As noted in the change order documentation provided by Milestone, the flashing arrow sign is not included in the price of this change order.

Change Order Explanation for Specific Line Item

It is the intent of the parties that this change order is full and complete compensation for the work describe above.
Notification and consent to this change order is hereby acknowledged.

Contractor:_____

Signed By:_____

Date:_____

NOTE: Other required State and FHWA signatures will be obtained electronically through the SiteManager system.

APPROVED FOR LOCAL PUBLIC AGENCY

(SIGNATURE)

(TITLE)

(DATE)

(SIGNATURE)

(TITLE)

(DATE)

SUBMITTED FOR CONSIDERATION

PE/S _____

APPROVED FOR INDIANA DEPARTMENT OF TRANSPORTATION

Approval Level	Name of Approver	Date	Status
Project Engineer/Supervisor	Decker, Lawrence	00/00/0000	Action Pending



Board of Public Works Staff Report

Project/Event:	Reissuance of Permits for AEG Fiber Work
Staff Representative:	Alex Gray
Petitioner/Representative:	Bret Simons
Date:	May 6 th , 2024

Report: AEG is requesting the extension of previously approved permits with this Board meeting consisting of 2 permits out of their requested 10 or so permits. The permit extensions are due to scheduling changes that AEG has had to enact in their fiber install work within the City's ROW. For this quarter the Board will see a series of permits every meeting to extend so that AEG can be caught up with their scheduling changes. The permits that are being requested for extension at this Board meeting are below.

S Maxwell St This area includes work south of E Hillside Dr between S High St and S Huntington Dr and as far south as Winslow Woods Park. The work is expected to be completed by June 24th with active work occurring after the Board meeting through May 21st.

N Williams St/ W 5th St This area travels along N Maple St by Reverend Ernest Butler Park south to W 3rd St. The neighborhoods in this area between N Elm St and N Rogers St will also see activity. The work is expected to be completed by June 24th with active work occurring after the Board meeting through May 21st.



P.O. Box 349 | Buford, Georgia 30515
Main Office: (706)654-2298
www.aeg.cc

To: City of Bloomington – Engineering Department

Subject: City of Bloomington Right of Way Application Extension

Dear Board Members,

AEG is respectfully requesting an extension to access the ROWs on expired permits in the city.

We are asking for extensions on the following permits. We were unable to finish or start work in these areas due to unforeseen circumstances (Pole Co-op not responding in a timely manner). All work will be completed in these areas by June 24th, 2024.

BLN01b-F13_N Crescent Rd – Completion date 5/27/24
BLN01a-F06_Hoosier Court Ave – Completion date 4/30/24
BL24 - E 16th St – Completion date 4/30/24
BLN01a-F14_N Lincoln St – Completion date 5/13/24
BLN01a-F02_E 19th St – Completion date 5/27/24
BLN01b-F12_N Hay St – Completion date 5/27/24
BLN01b-F11_N Williams St – Completion date 6/3/24
BLC01a-F08 - E Rogers Rd – Completion date 6/3/24
BLC02a-F14_S Maxwell St – Completion date 6/3/24
BLN01b-F10_N Morton St – Completion date 6/10/24
BLC01a-F07 - S Long Hill Dr – Completion date 6/24/24

Bret Simons
Engineering Permit Coordinator
Atlantic Engineering Group

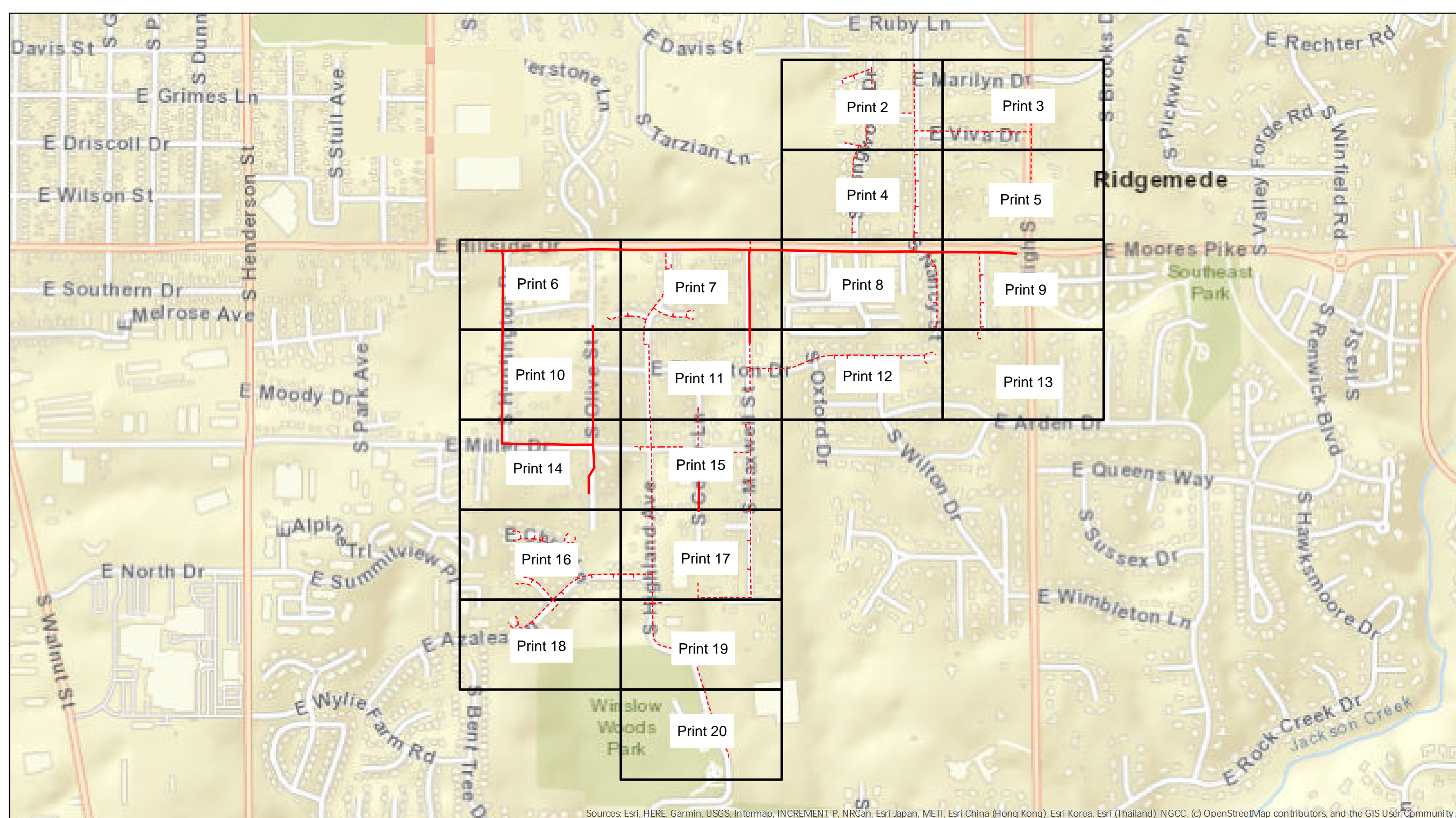

Sources: Esri, HERE, Garmin, USGS, Intermap, INCREMENT P, NRCan, Esri Japan, METI, Esri China (Hong Kong), Esri Korea, Esri (Thailand), NGCC, (c) OpenStreetMap contributors, and the GIS User Community



Legend BLC02a-F14_S Maxwell St

- Overhead Strand
- ⋯ Conduit
- Grids

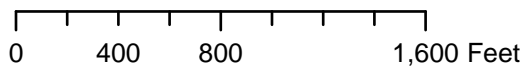

City of Bloomington, IN Permit:
Design View

INI	BY	DATE	DESCRIPTION



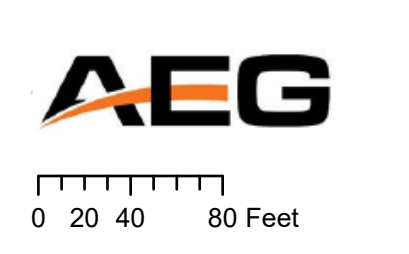
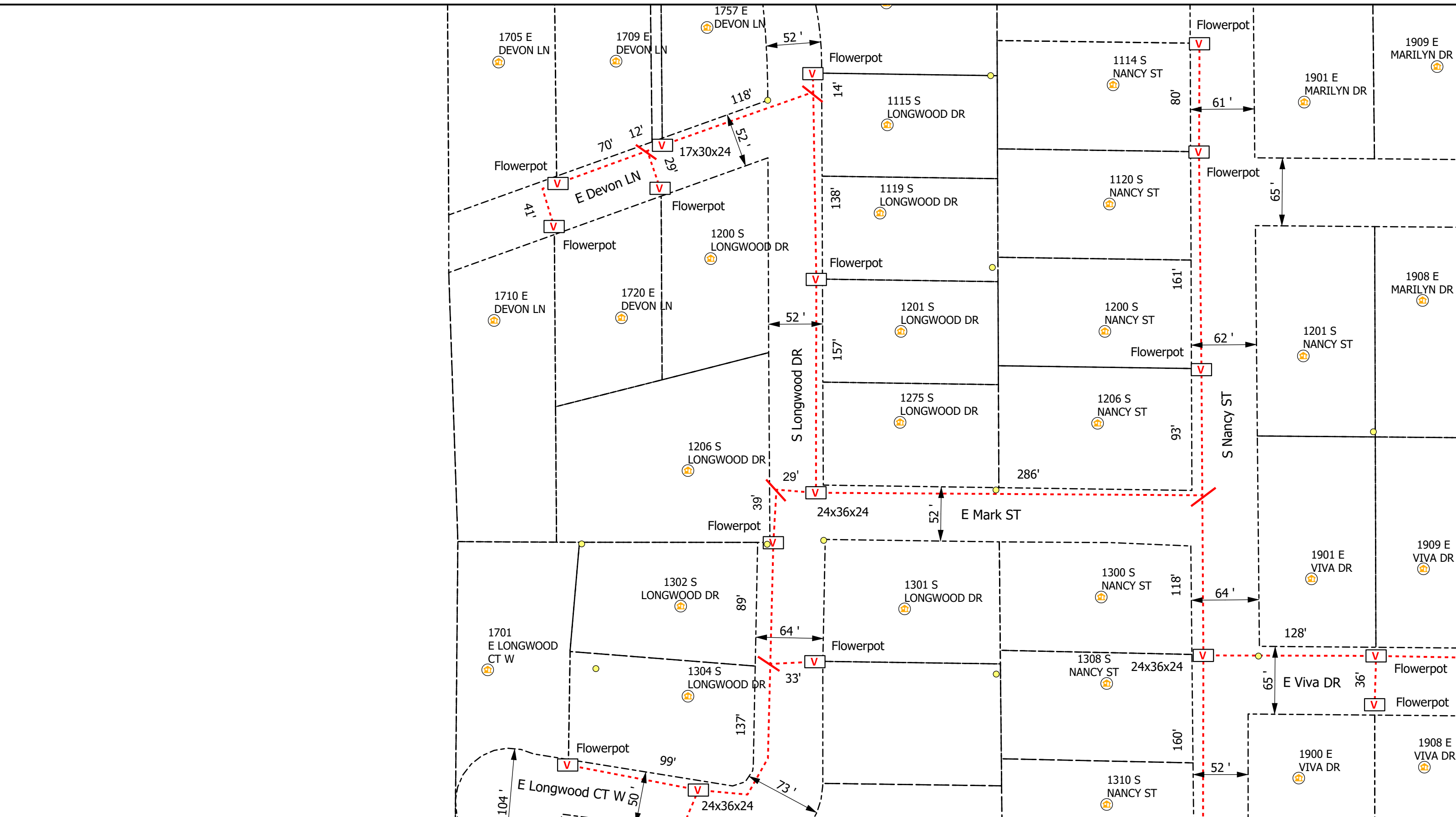

- Legend**
- Poles
 - V Vaults
 - Overhead Strand
 - Conduit
 - Bloomington_Parcels
 - R Risers
 - A Address
 - Y Anchor
 - ← Sidewalk
 - Grids

All Flowerpots 12" DIA

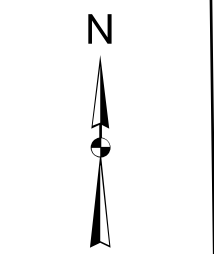

City of Bloomington, IN Permit:
Design View

INI	BY	DATE	DESCRIPTION

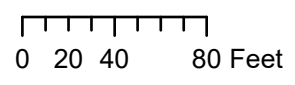
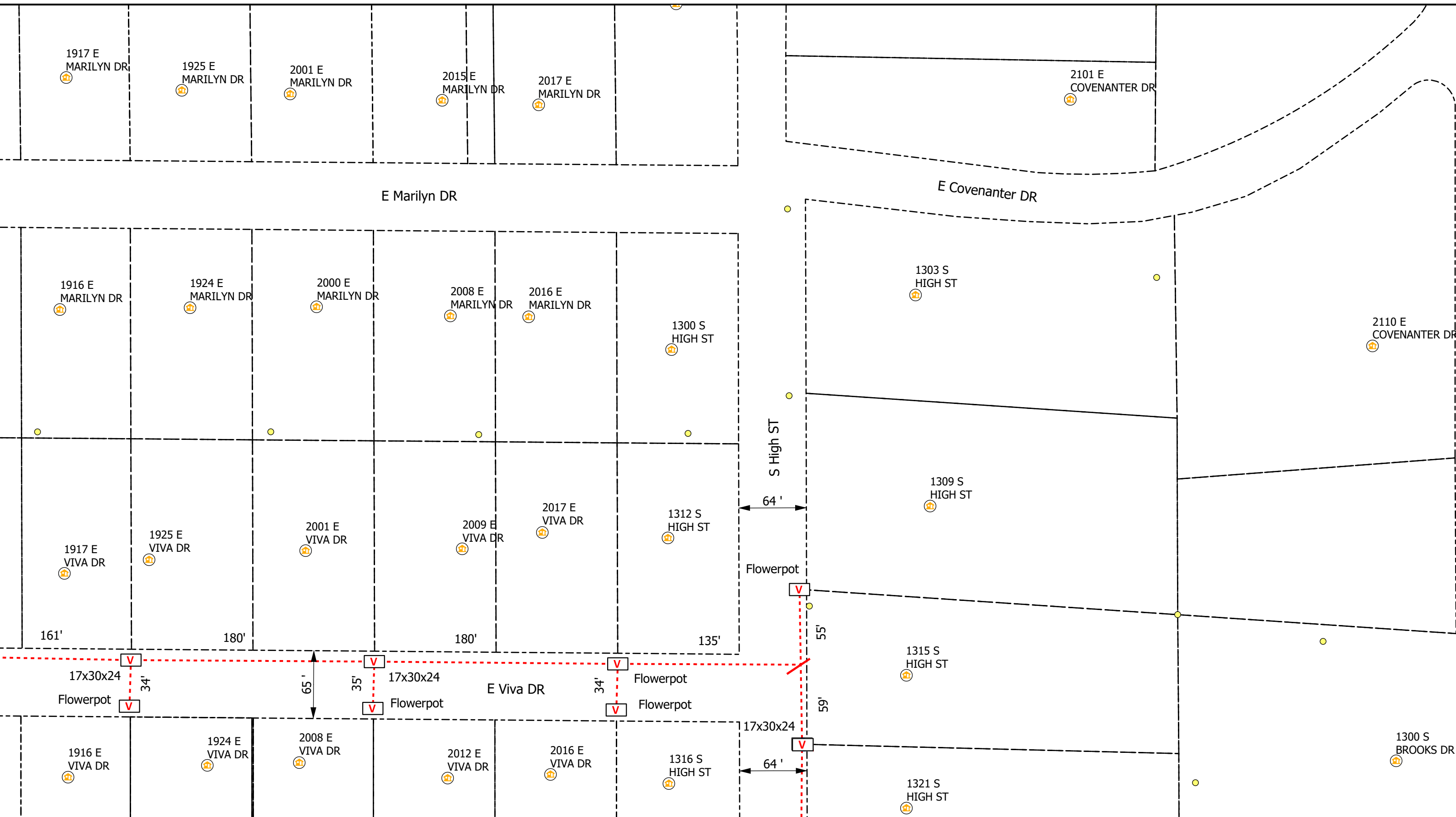

Legend

- Poles
- V Vaults
- Overhead Strand
- Conduit
- Bloomington_Parcels
- R Risers
- A Address
- Y Anchor
- ← Sidewalk
- Grids

All Flowerpots 12" DIA



City of Bloomington, IN Permit:
Design View

INI	BY	DATE	DESCRIPTION



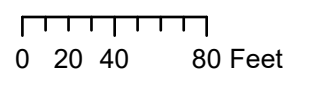
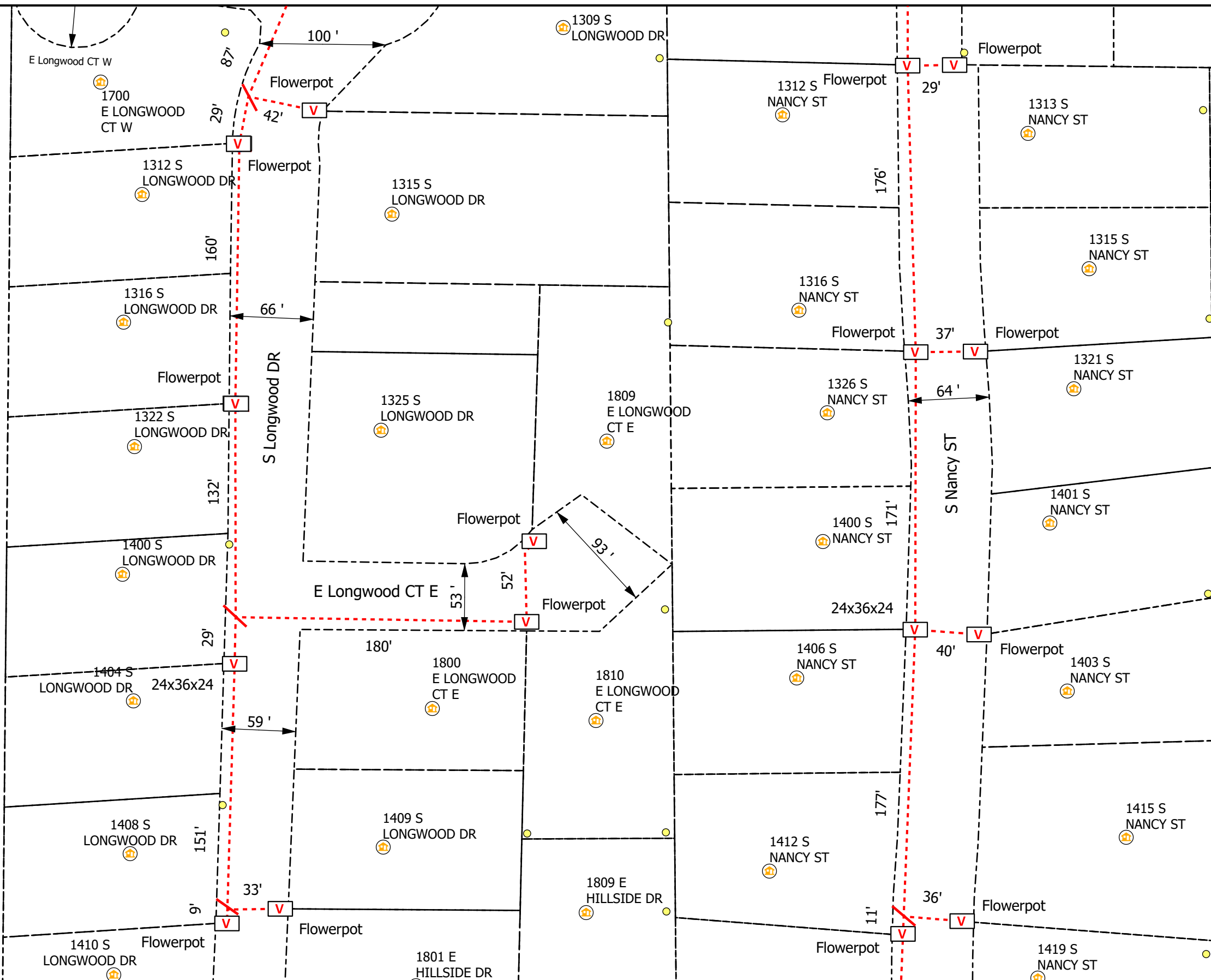

Legend

- Poles
- V Vaults
- Overhead Strand
- Conduit
- Bloomington_Parcels
- R Risers
- ⊙ Address
- Y Anchor
- ← Sidewalk
- Grids

All Flowerpots 12" DIA



City of Bloomington, IN Permit:
Design View

INI	BY	DATE	DESCRIPTION



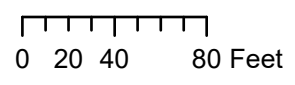
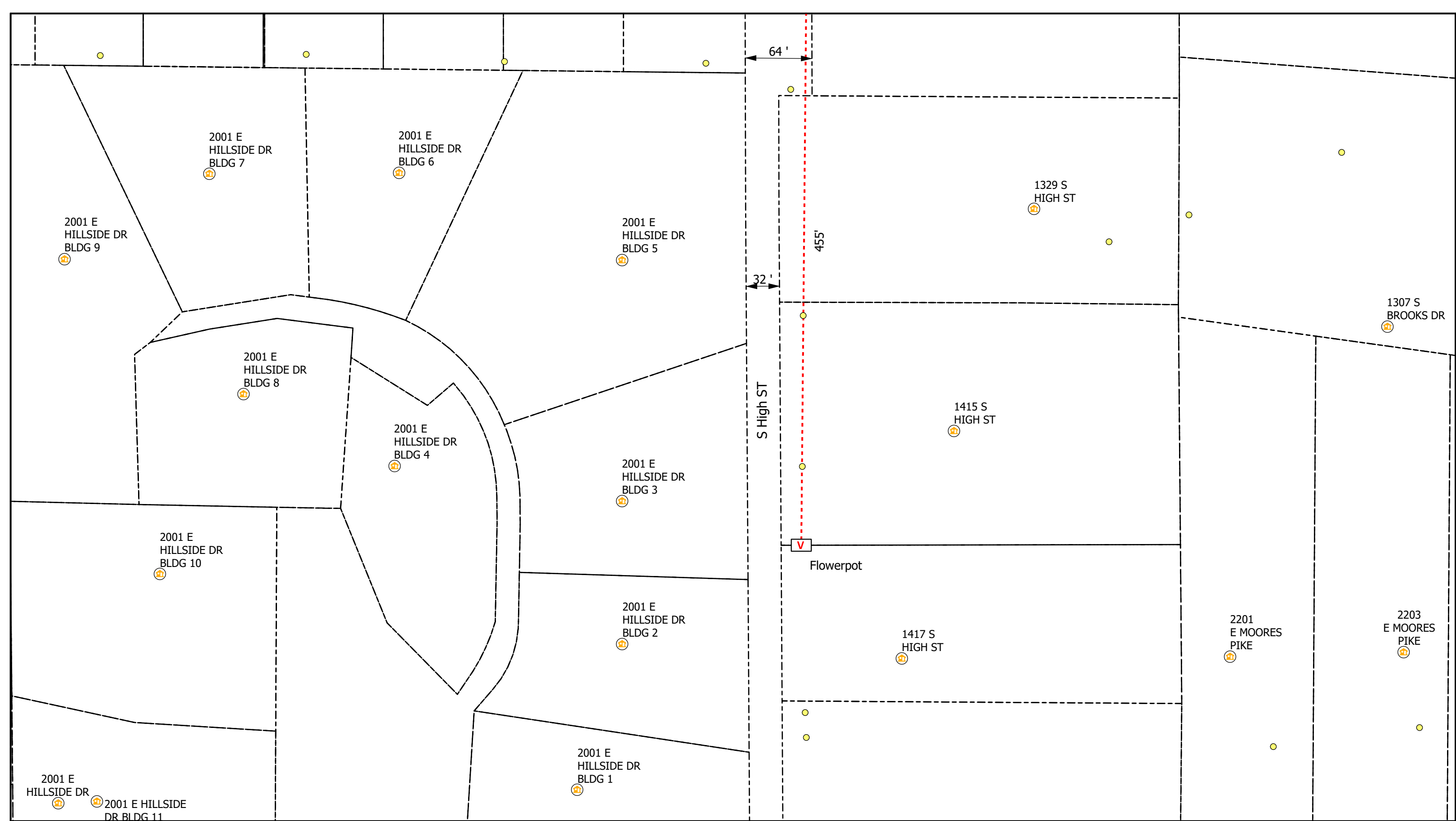

Legend

- Poles
- V Vaults
- Overhead Strand
- - - Conduit
- Bloomington_Parcels
- Ⓡ Risers
- Ⓜ Address
- Y Anchor
- ← Sidewalk
- Grids

All Flowerpots 12" DIA



City of Bloomington, IN Permit:
Design View

INI	BY	DATE	DESCRIPTION



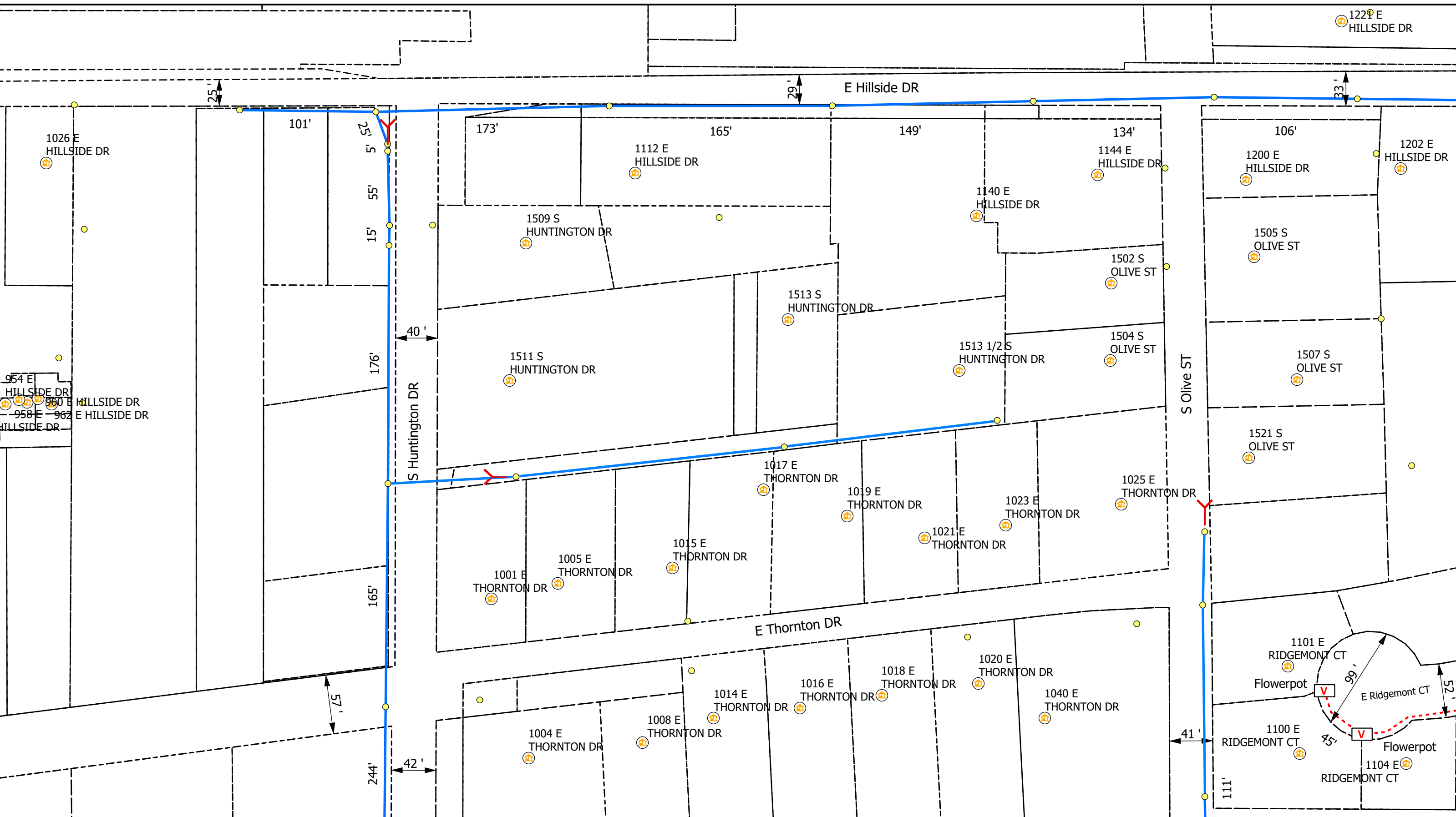

Legend

- Poles
- V Vaults
- Overhead Strand
- Conduit
- Bloomington_Parcels Bloomington_Parcels
- R Risers
- Address Address
- Y Anchor
- ← Sidewalk
- Grids Grids

All Flowerpots 12" DIA

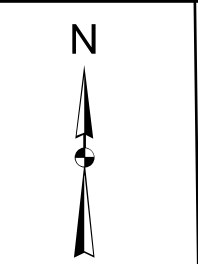

City of Bloomington, IN Permit:
Design View

INI	BY	DATE	DESCRIPTION

Print 6 of 20

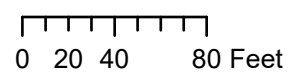
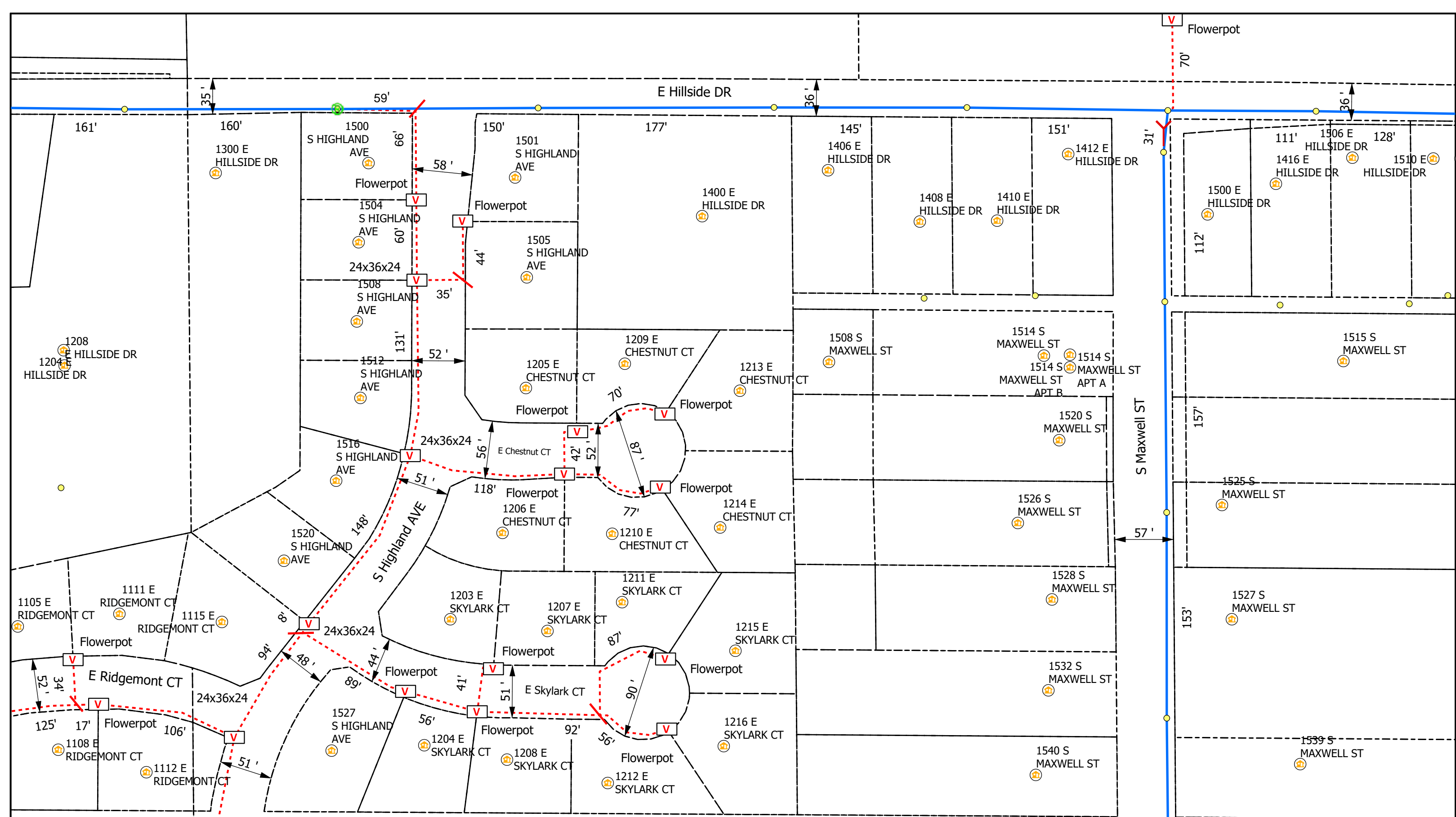

Legend

- Poles
- Vaults
- Overhead Strand
- Conduit
- Bloomington_Parcels
- Risers
- Address
- Anchor
- Sidewalk
- Grids

All Flowerpots 12" DIA



City of Bloomington, IN Permit:
Design View

INI	BY	DATE	DESCRIPTION



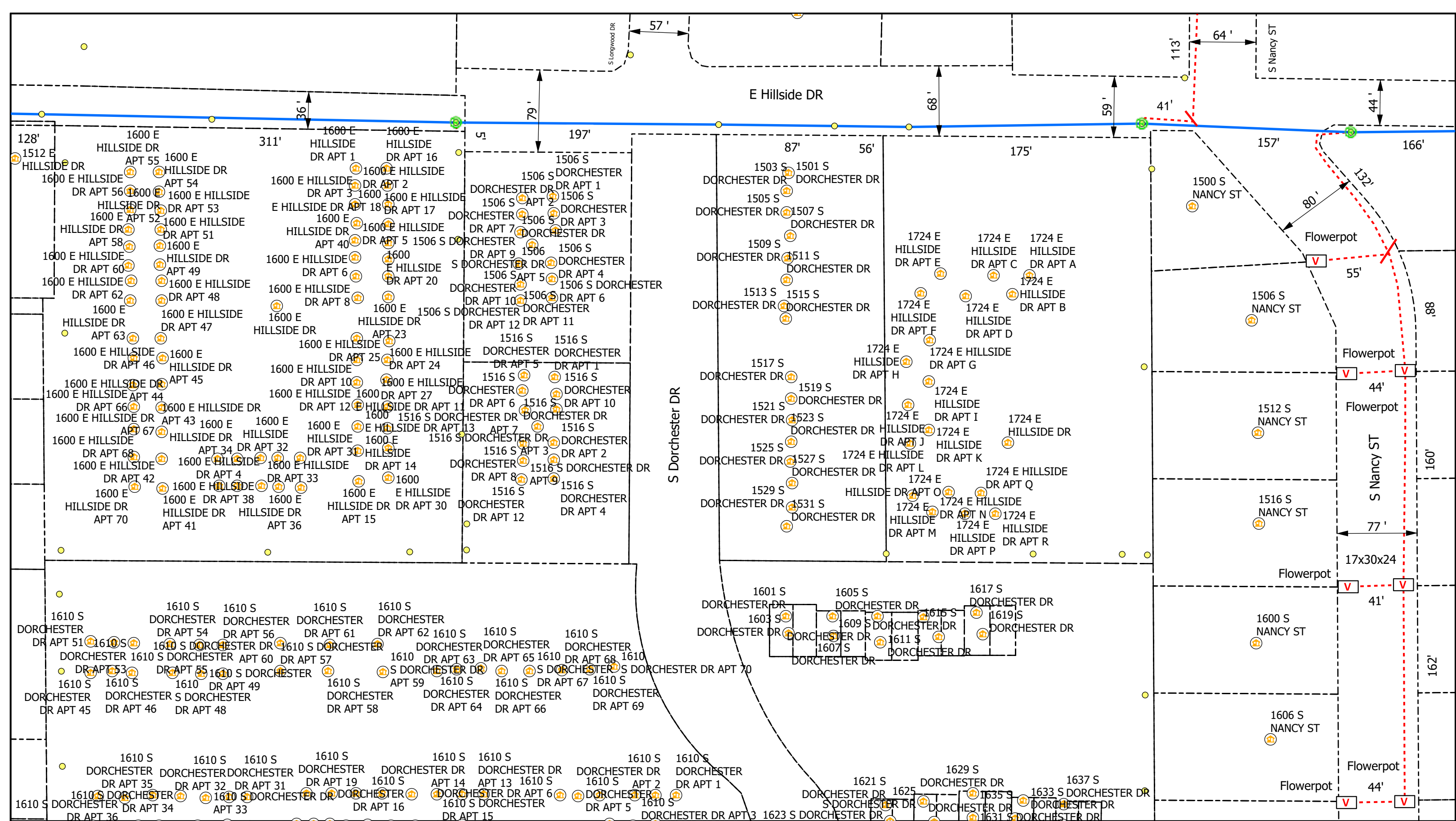

0 20 40 80 Feet

Legend

- Poles
- Vaults
- Overhead Strand
- Conduit
- Bloomington_Parcels
- Risers
- Address
- Anchor
- Sidewalk
- Grids

All Flowerpots 12" DIA

N



City of Bloomington, IN Permit:
Design View

INI	BY	DATE	DESCRIPTION



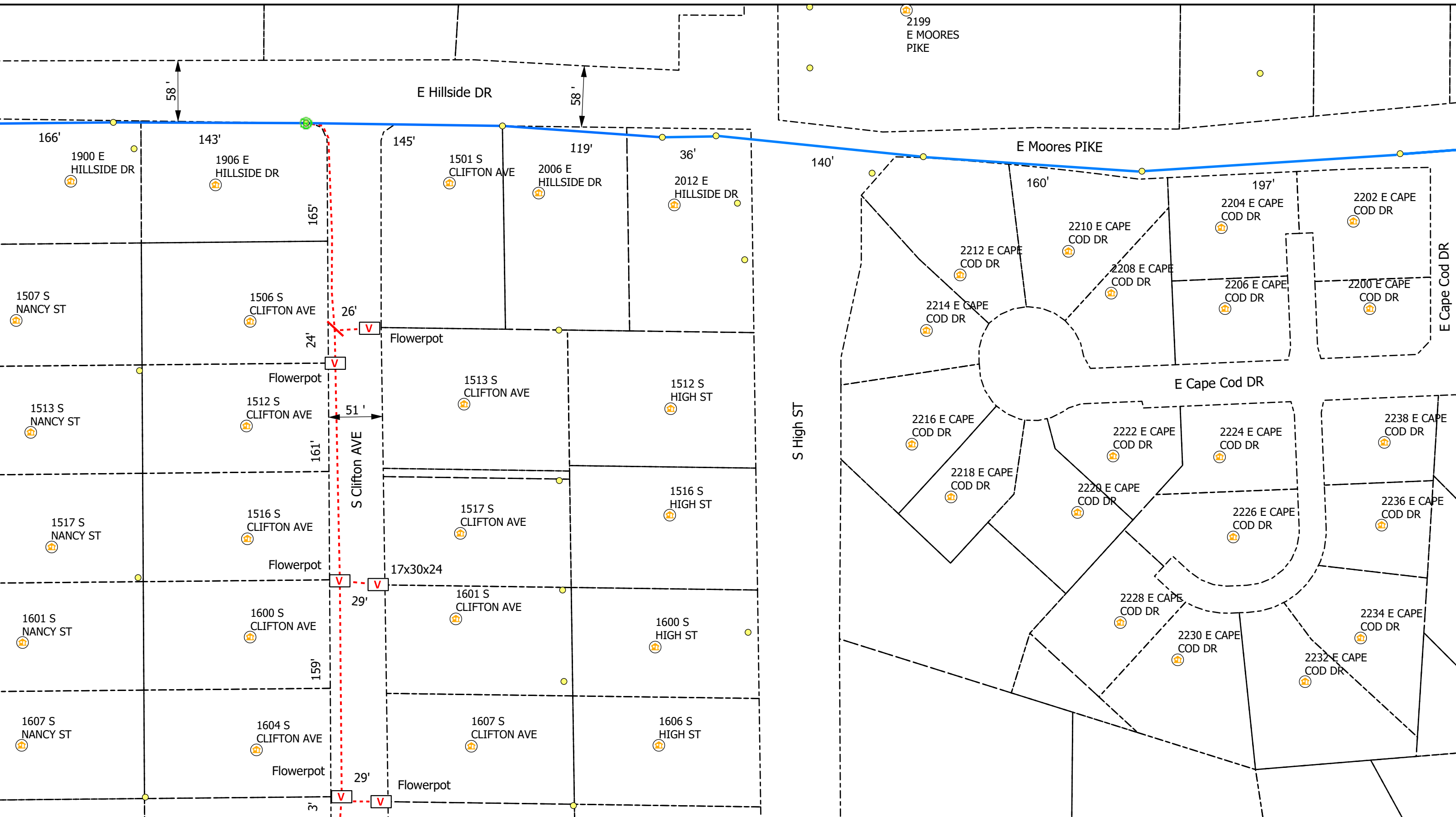

0 20 40 80 Feet

Legend

- Poles
- V Vaults
- Overhead Strand
- Conduit
- R Risers
- A Address
- Y Bloomington_Parcels
- Y Anchor
- ← Sidewalk
- Grids

All Flowerpots 12" DIA

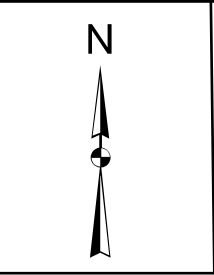

City of Bloomington, IN Permit:
Design View

INI	BY	DATE	DESCRIPTION

Print 9 of 20

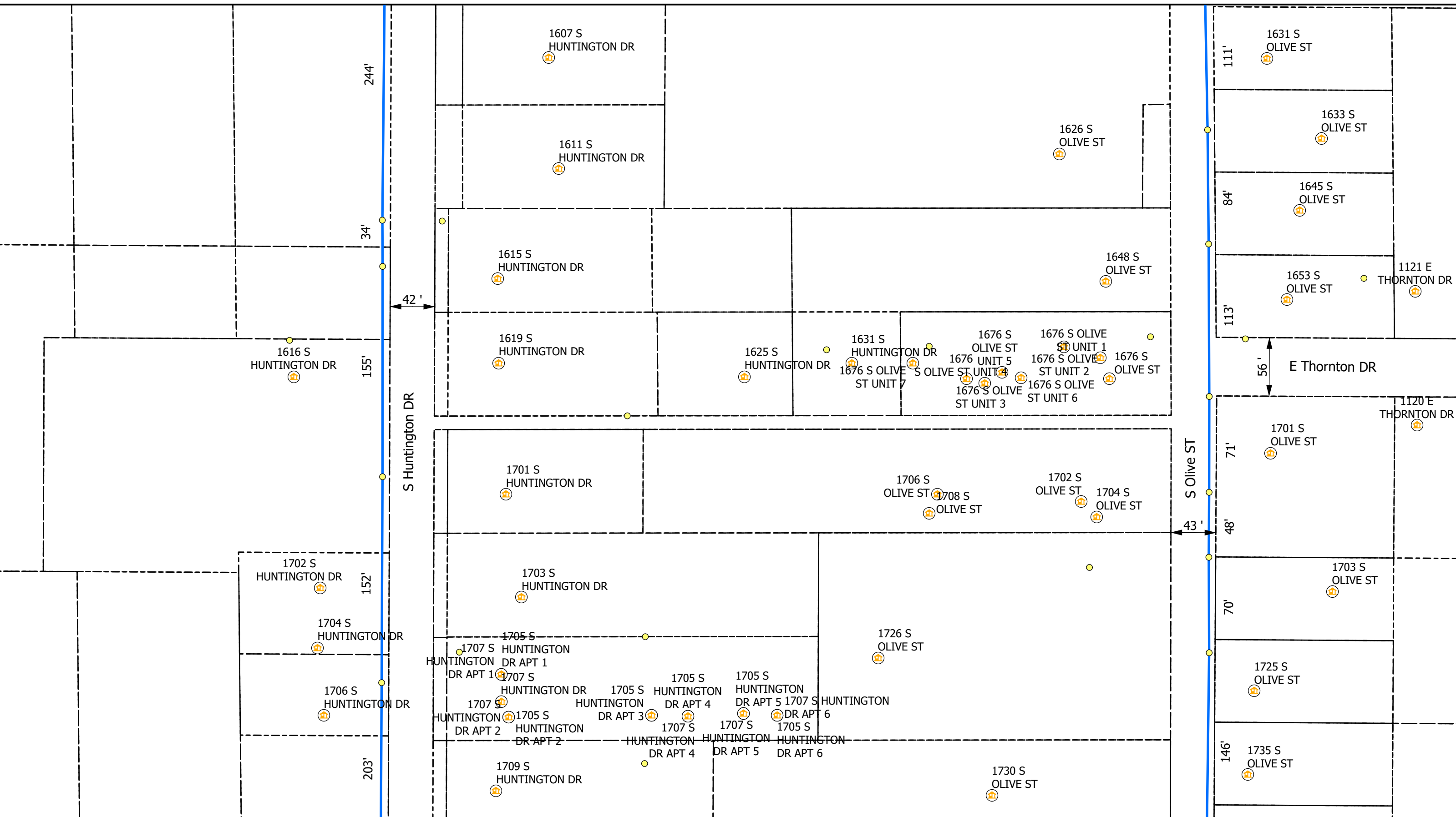

0 20 40 80 Feet

Legend

- Poles
- V Vaults
- Overhead Strand
- Conduit
- Bloomington_Parcels
- R Risers
- A Address
- Y Anchor
- ← Sidewalk
- Grids

All Flowerpots 12" DIA



City of Bloomington, IN Permit:
Design View

INI	BY	DATE	DESCRIPTION



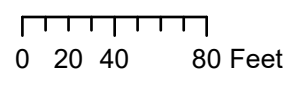
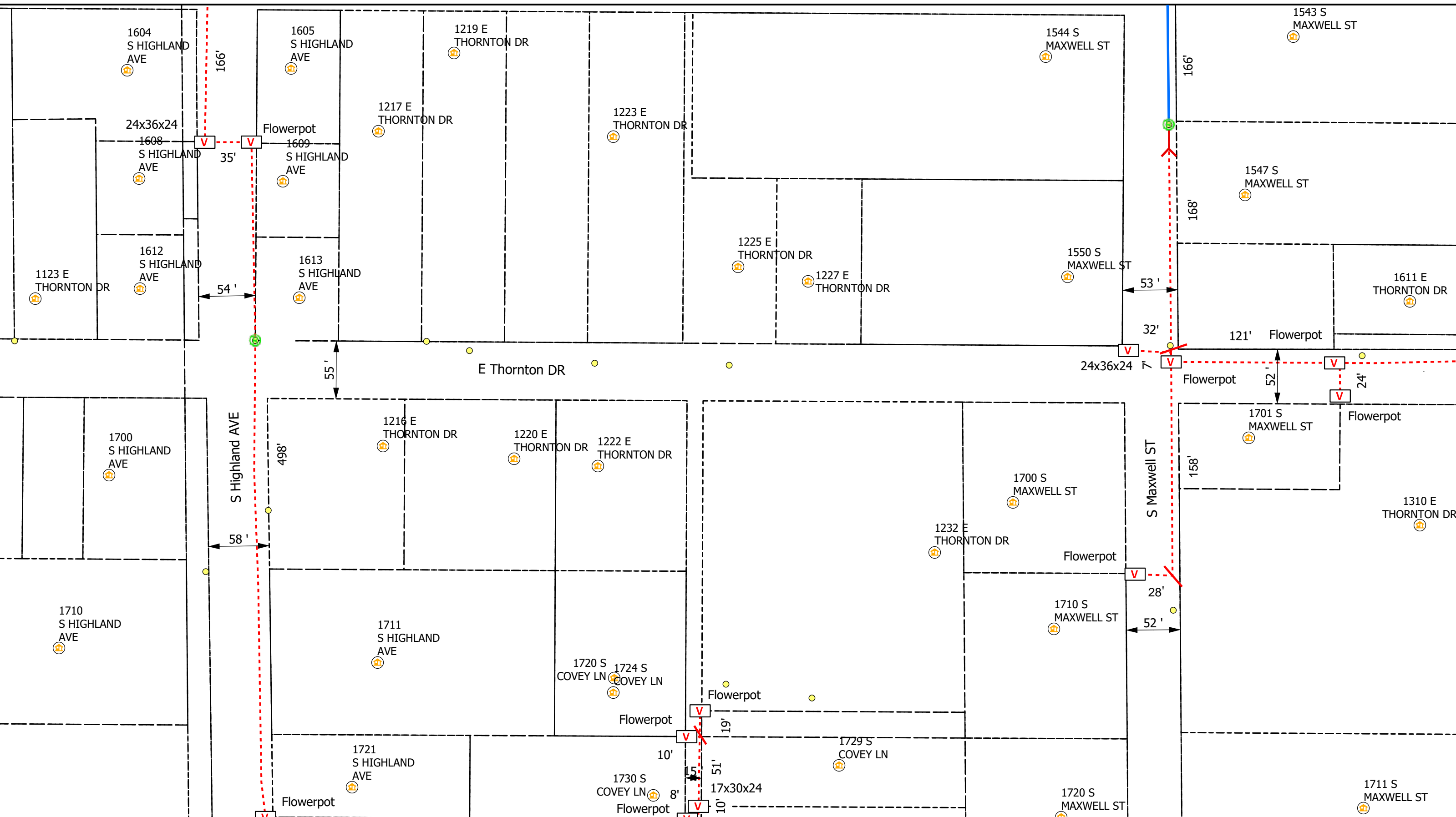

Legend

- Poles
- Risers
- Overhead Strand
- Conduit
- Bloomington_Parcels
- Address
- Grids
- Anchor
- Sidewalk

All Flowerpots 12" DIA



City of Bloomington, IN Permit:
Design View

INI	BY	DATE	DESCRIPTION



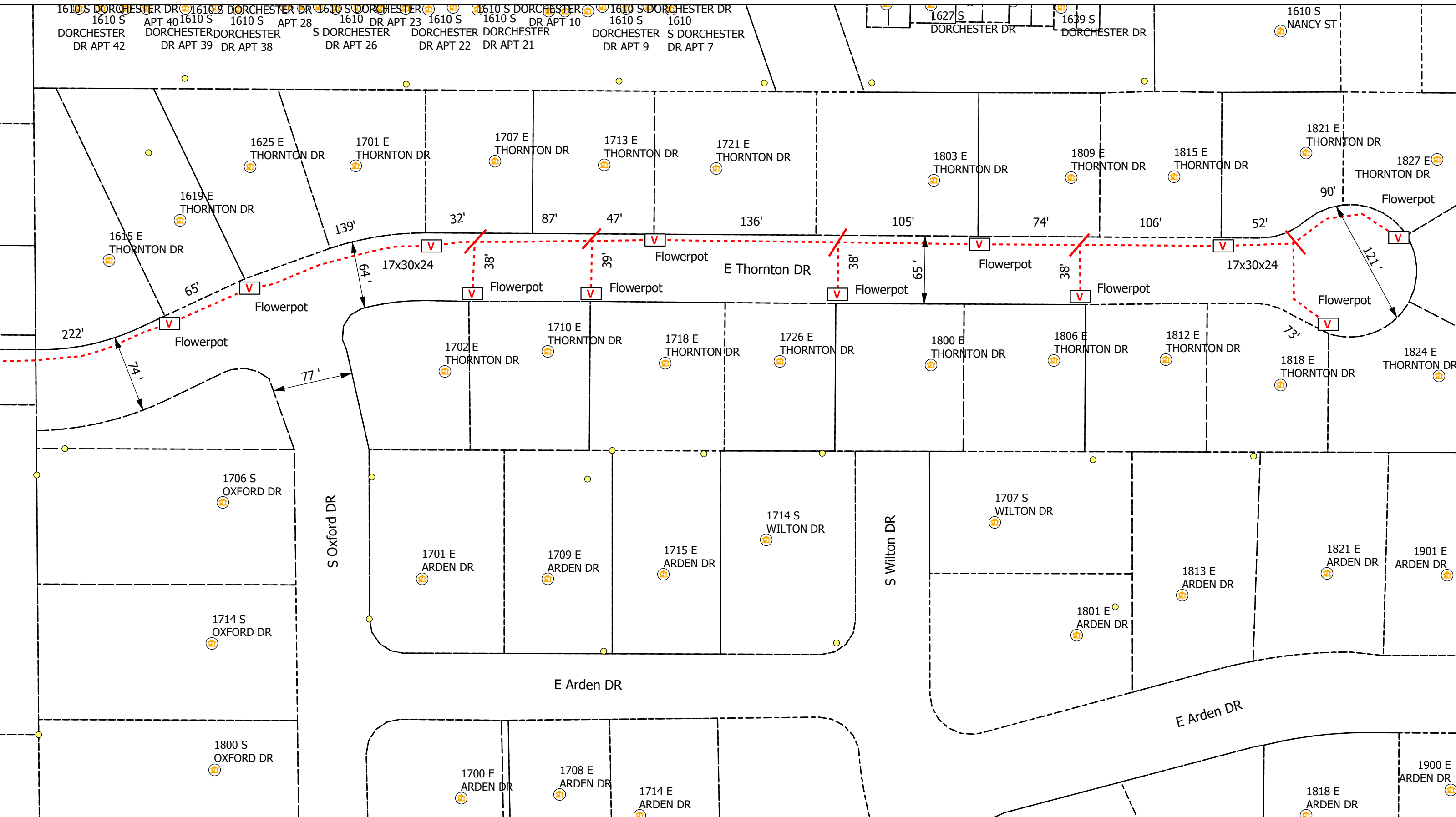

Legend

- Poles
- Ⓜ Vaults
- Overhead Strand
- - - Conduit
- Ⓜ Bloomington_Parcels
- Ⓜ Risers
- Ⓜ Address
- Ⓜ Anchor
- Ⓜ Sidewalk
- Ⓜ Grids

All Flowerpots 12" DIA

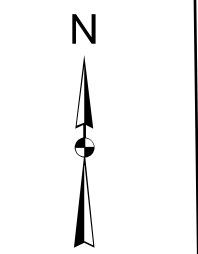

City of Bloomington, IN Permit:
Design View

INI	BY	DATE	DESCRIPTION

Print 12 of 20

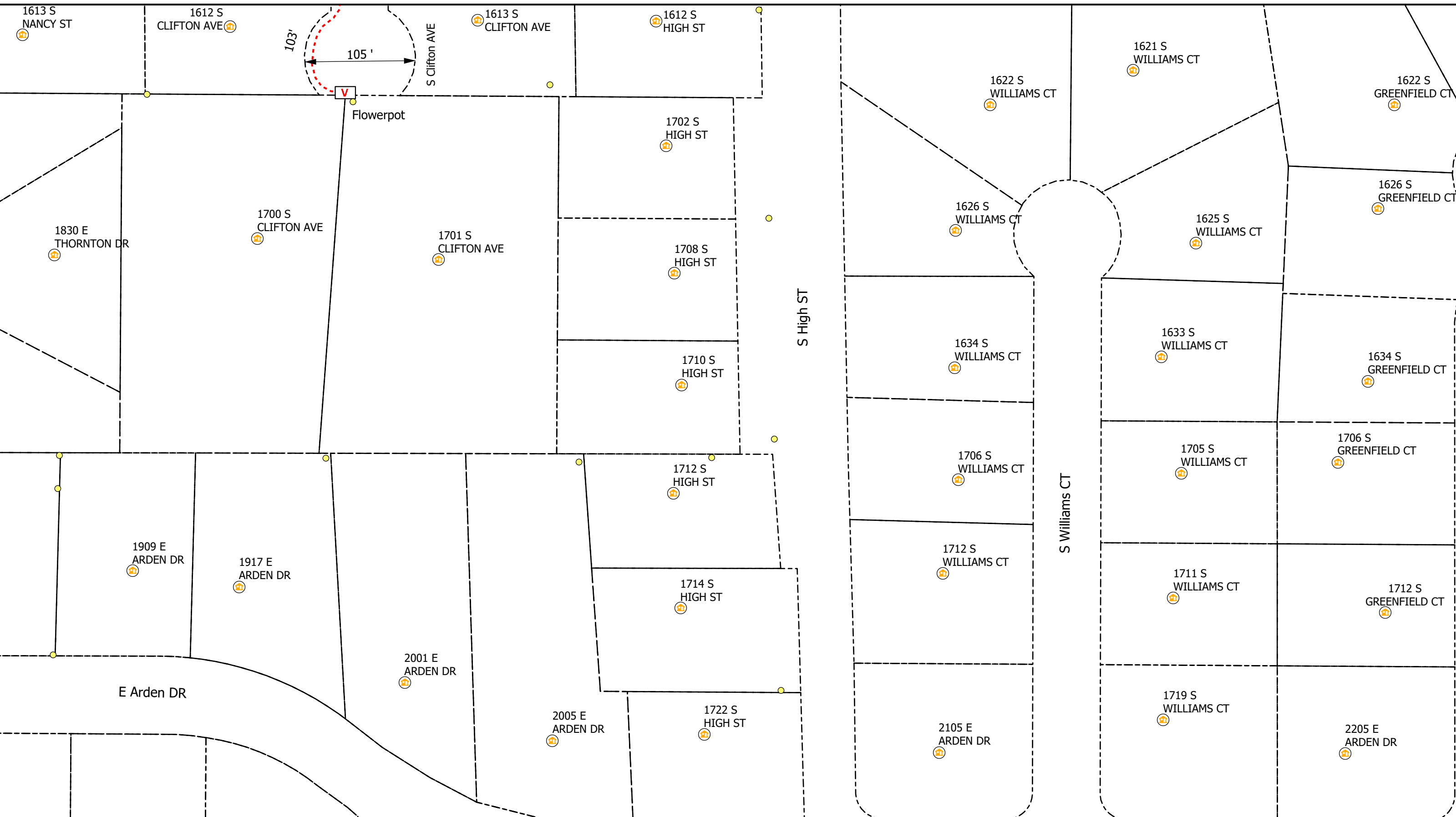

AEG

0 20 40 80 Feet

Legend

- Poles
- Bloomington_Parcels
- Vaults
- Risers
- Overhead Strand
- Address
- Conduit
- Anchor
- Sidewalk
- Grids

All Flowerpots 12" DIA

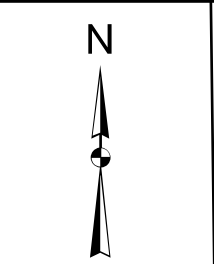

City of Bloomington, IN Permit:
Design View

INI	BY	DATE	DESCRIPTION

Indiana 811

Print 13 of 20

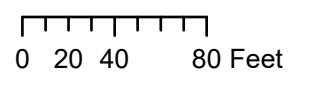
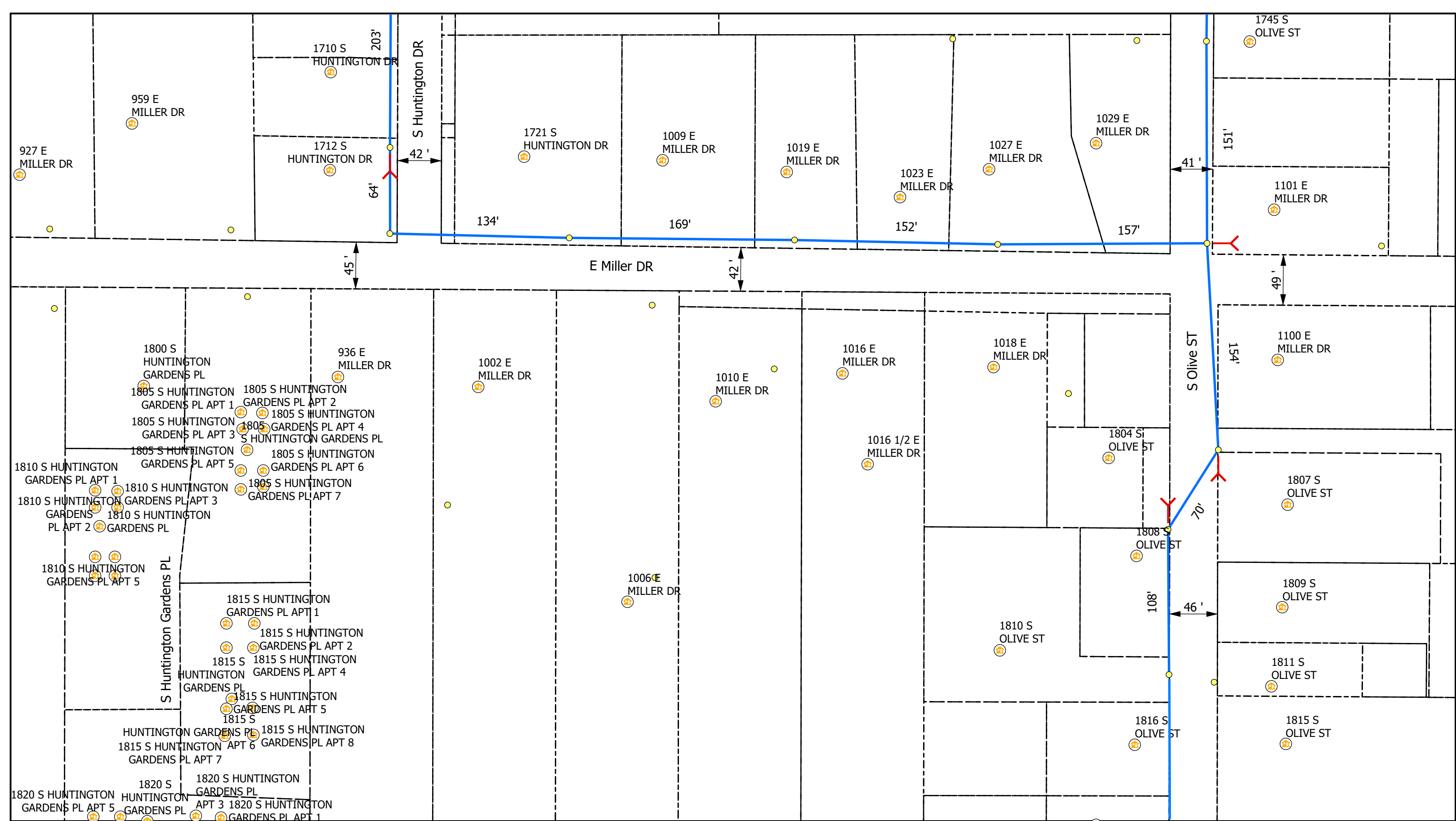

Legend

- Poles
- Vaults
- Overhead Strand
- Conduit
- Bloomington_Parcels
- Risers
- Address
- Anchor
- Sidewalk
- Grids

All Flowerpots 12" DIA



City of Bloomington, IN Permit:
Design View

INI	BY	DATE	DESCRIPTION



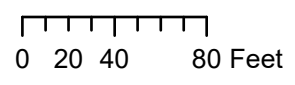
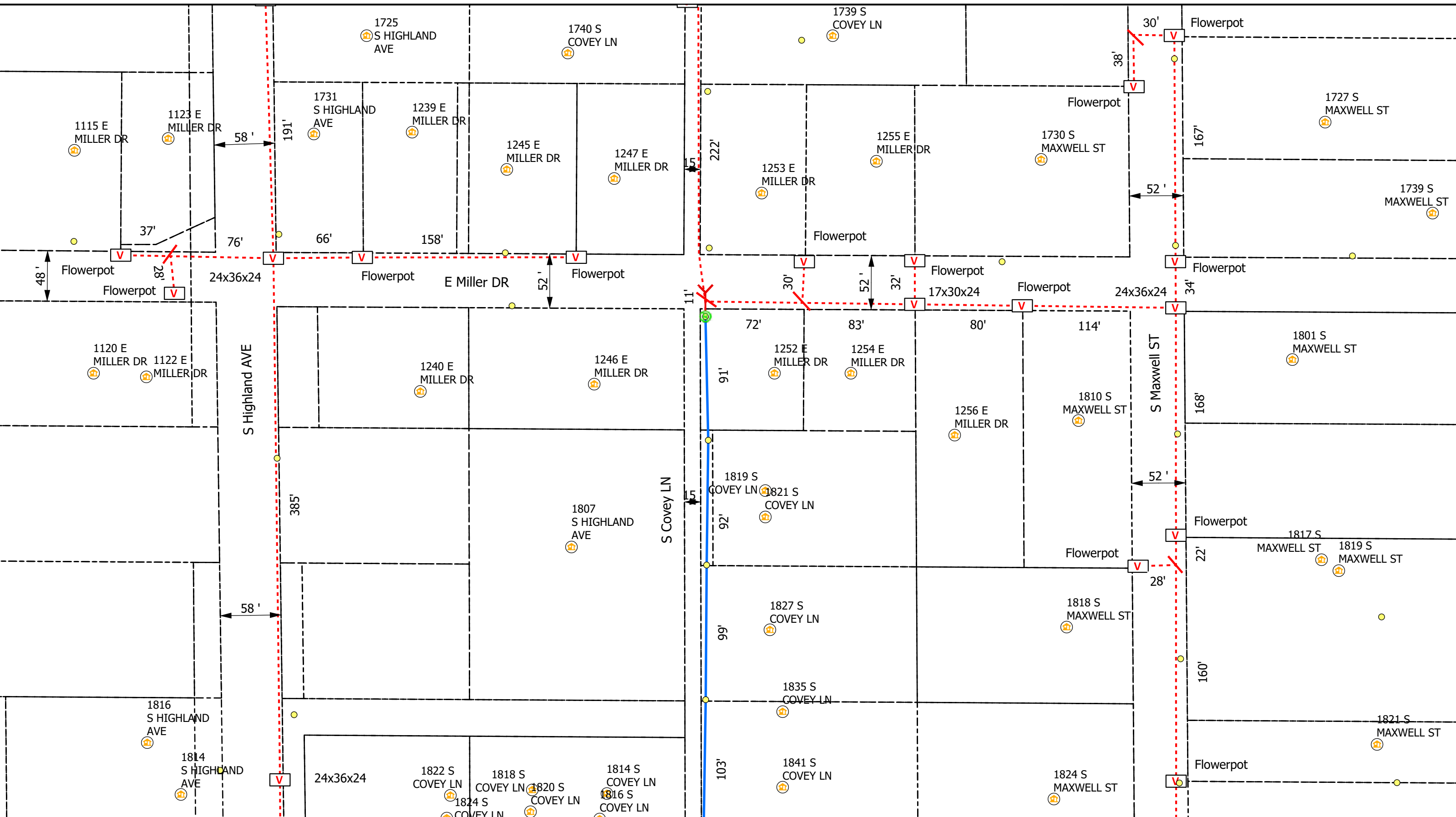

Legend

- Poles
- Vaults
- Overhead Strand
- Conduit
- Bloomington_Parcels
- Risers
- Address
- Anchor
- Sidewalk
- Grids

All Flowerpots 12" DIA



City of Bloomington, IN Permit:
Design View

INI	BY	DATE	DESCRIPTION



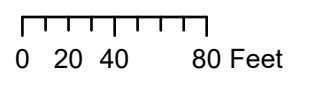
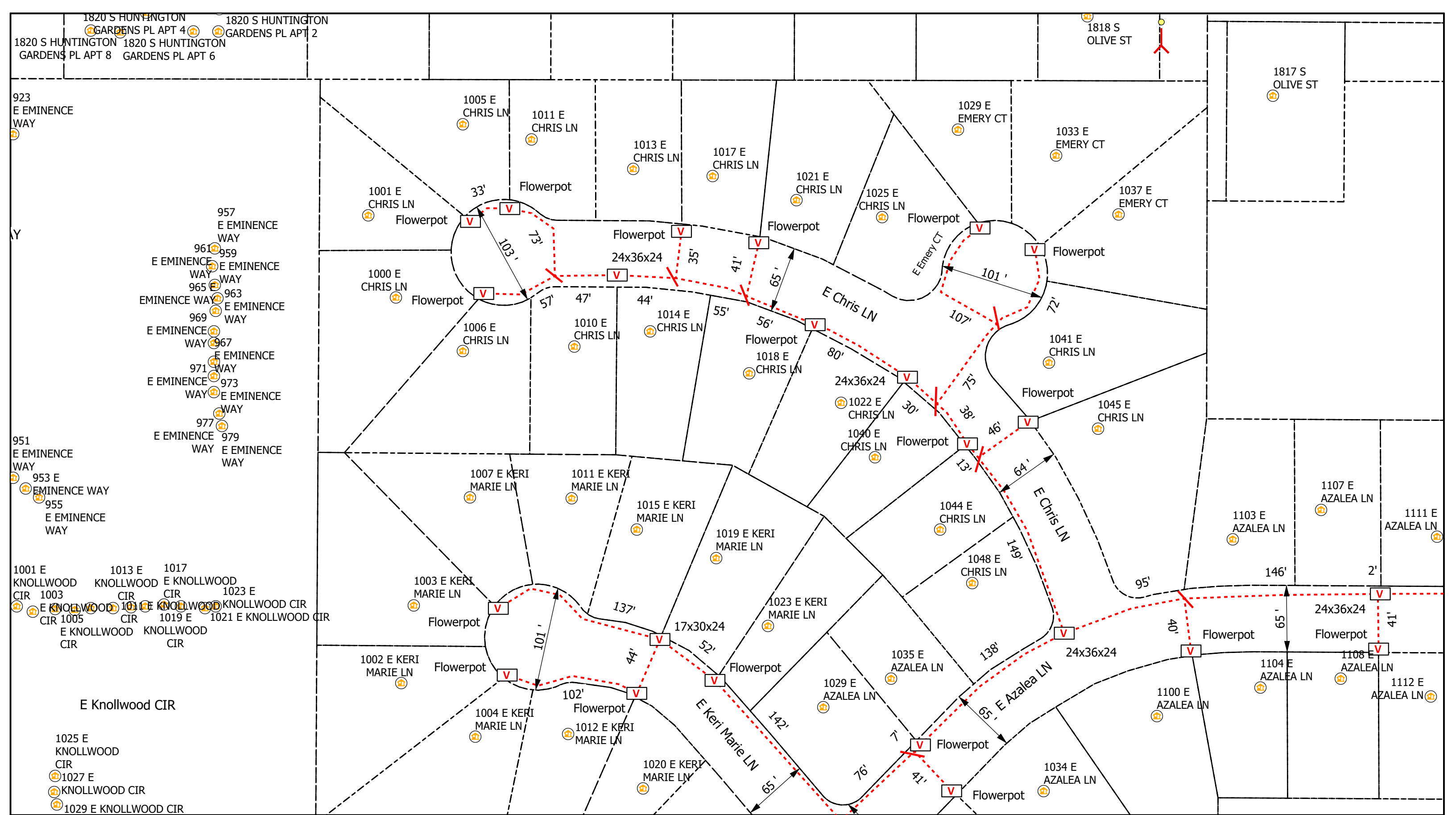

Legend

- Poles
- Vaults
- Overhead Strand
- Conduit
- Bloomington_Parcels
- Risers
- Address
- Anchor
- Sidewalk
- Grids

All Flowerpots 12" DIA



City of Bloomington, IN Permit:
Design View

INI	BY	DATE	DESCRIPTION



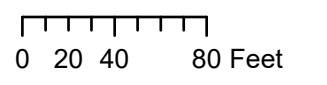
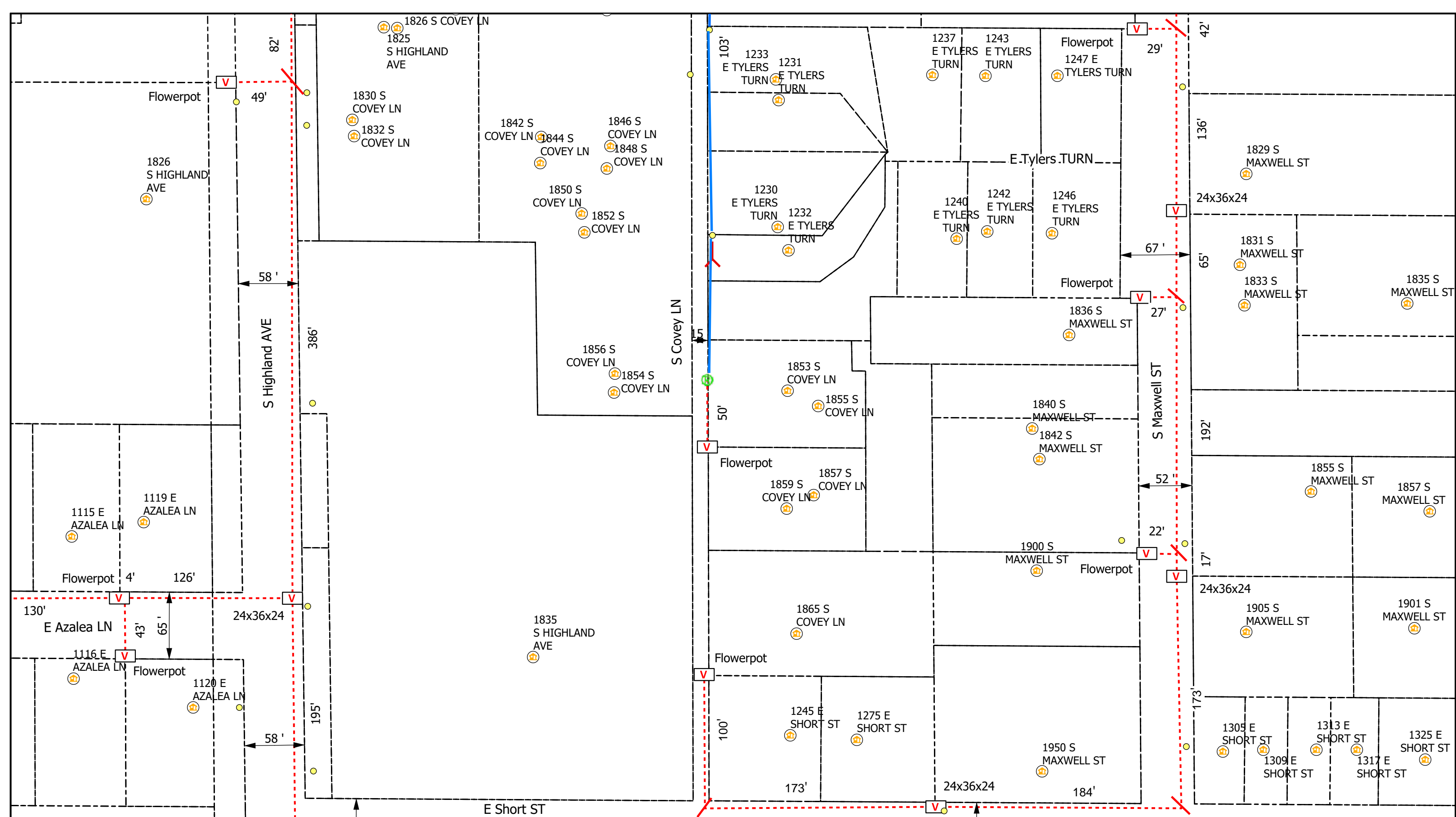

Legend

- Poles
- Conduit
- Overhead Strand
- Anchor
- Sidewalk
- Grids
- Bloomington_Parcels
- Risers
- Address

All Flowerpots 12" DIA



City of Bloomington, IN Permit:
Design View

INI	BY	DATE	DESCRIPTION



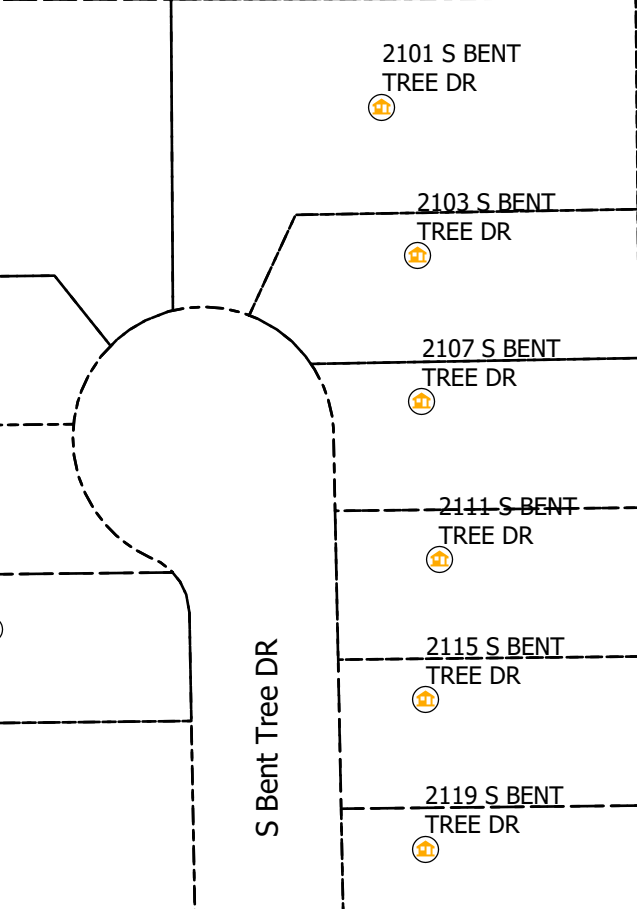
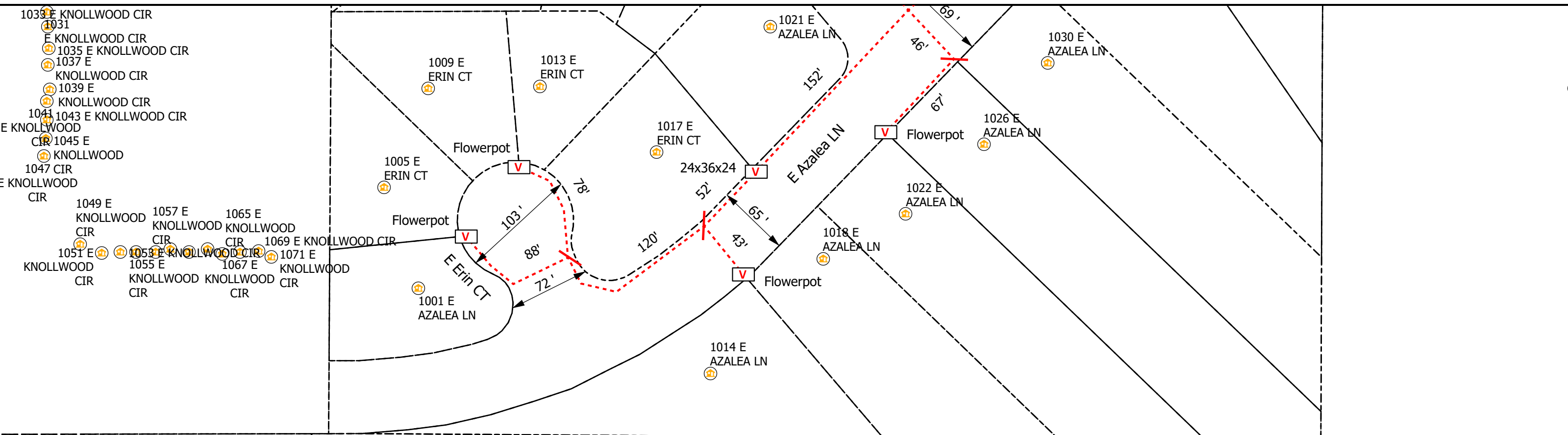

Legend

- Poles
- Vaults
- Overhead Strand
- Conduit
- Bloomington_Parcels
- Risers
- Address
- Anchor
- Sidewalk
- Grids

All Flowerpots 12" DIA



City of Bloomington, IN Permit:
 Design View

INI	BY	DATE	DESCRIPTION



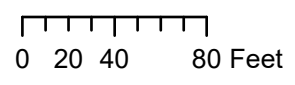
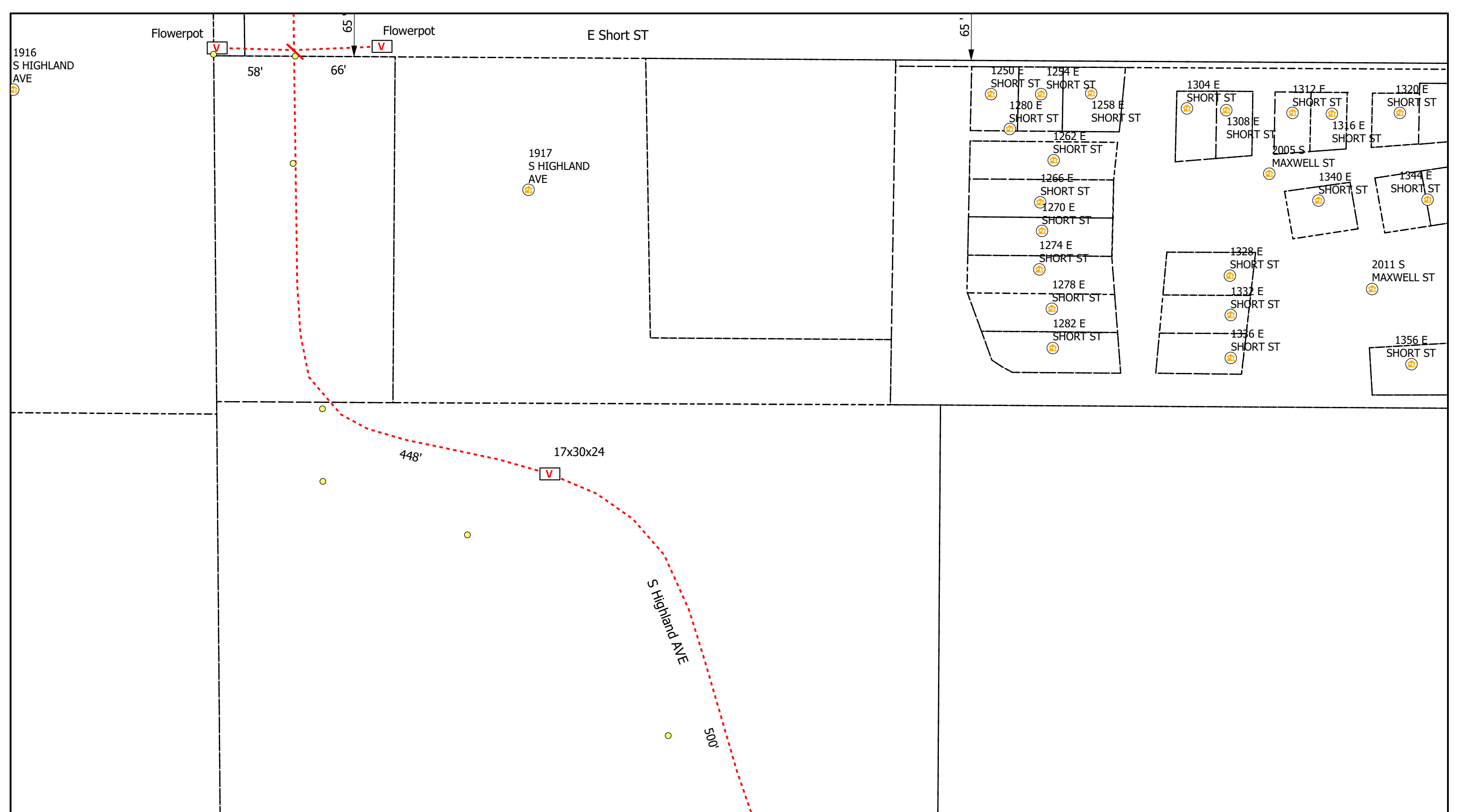

Legend

- Poles
- V Vaults
- Overhead Strand
- - - Conduit
- Bloomington_Parcels
- Ⓡ Risers
- Ⓜ Address
- Y Anchor
- ← Sidewalk
- Grids

All Flowerpots 12" DIA



City of Bloomington, IN Permit:
Design View

INI	BY	DATE	DESCRIPTION



2125
S HIGHLAND
AVE

2120
S HIGHLAND
AVE

V
Flowerpot











S Highland AVE

V
17x30x24

5A'

307'

Legend

-  Poles
-  Vaults
-  Overhead Strand
-  Conduit
-  Bloomington_Parcels
-  Risers
-  Address
-  Anchor
-  Sidewalk
-  Grids

All Flowerpots 12" DIA



City of Bloomington, IN Permit:
Design View

INI	BY	DATE	DESCRIPTION



0 20 40 80 Feet

Carlton® PV-Mold® Nonmetallic Pole Riser System

Carlton PV-Mold is a nonmetallic pole riser system designed to protect communications power cable installed on poles.

Features:

- Meets or exceeds requirements outlined in the National Electric Safety Code (NESC).
- Designed in accordance with NEMA TC-19 specifications.
- Ultraviolet, cold temperature and corrosive atmosphere resistant.
- Schedule 40 wall meets Schedule 80 PVC conduit impact requirements per NEMA TC-19.
- No grounding required.
- Belled end fits over each added section or conduit.
- Flame retardant.
- Requires no maintenance.
- PV-Mold acts as an insulator against electrical shock.
- Interchangeable parts and accessories to match the needs of specific requirements.



Steel U-Guard requires grounding strapping and does not have belled ends.



PV-Mold has belled ends, flanged design and does not require grounding.

Flanged Overall Length 10 Feet, Including Bell

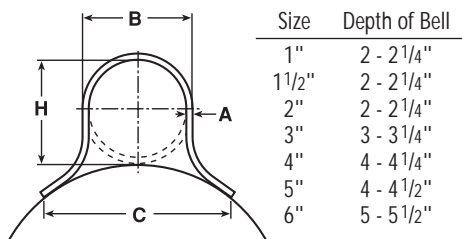

Slots are 1/2" from side to side, and allow for expansion and contraction.

Slot Dimensions: for sizes 2" through 6" are 5/16" wide, 3/4" long.

Slot Dimensions: for 1" and 1 1/2" are 3/16" wide, 3/4" long.

Slot Spacing: 18" from center, beginning 6" from end.

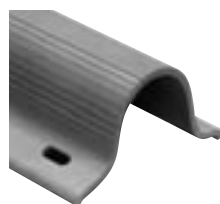

Standard Duty

Part No.	Size	Std. Ctn. Qty.	Std. Ctn. Wt. (lbs.)	Dimensions				Actual Impact @ 0°C 20 Pound Top
				A	B	C	H	
59208N	1"	294	1059	0.100"	1 5/8"	2 3/8"	1 5/8"	40 Ft.-Lbs.
59211N	2"	136	726	0.100"	2 3/8"	4 1/2"	2 3/8"	100 Ft.-Lbs.
59211X (5' length)	2"	136	363	0.100"	2 3/8"	4 1/2"	2 3/8"	100 Ft.-Lbs.
59213N	3"	66	761	0.150"	3 1/2"	6"	3 1/2"	110 Ft.-Lbs.
59213X (5' length)	3"	66	381	0.150"	3 1/2"	6"	3 1/2"	100 Ft.-Lbs.
59215N	4"	65	910	0.150"	4 1/2"	6 1/2"	4 1/2"	110 Ft.-Lbs.
59216N	5"	30	515	0.150"	5 1/2"	7 1/2"	5 1/2"	110 Ft.-Lbs.

Heavy Duty Schedule 40

59010N	1 1/2"	200	1142	0.145"	1 29/32"	3 1/2"	1 29/32"	100 Ft.-Lbs.
59011N	2"	136	1214	0.154"	2 3/8"	4 1/2"	2 3/8"	150 Ft.-Lbs.
59013N	3"	66	937	0.216"	3 1/2"	6"	3 9/32"	150 Ft.-Lbs.
59015N	4"	65	1621	0.237"	4 1/2"	6 1/2"	4 1/2"	260 Ft.-Lbs.
59015X (5' length)	4"	65	707	0.237"	4 1/2"	6 1/2"	4 1/2"	260 Ft.-Lbs.
59016N	5"	30	870	0.258"	5 1/2"	7 1/2"	5 1/2"	260 Ft.-Lbs.
59017N	6"	30	1160	0.280"	6 5/8"	8 3/4"	6 5/8"	260 Ft.-Lbs.

Extra Heavy Duty Schedule 80

59411N	2"	136	1549	0.218"	2 3/8"	4 1/2"	2 3/8"	300 Ft.-Lbs.
59413N	3"	66	1495	0.030"	3 1/2"	6"	3 1/2"	525 Ft.-Lbs.

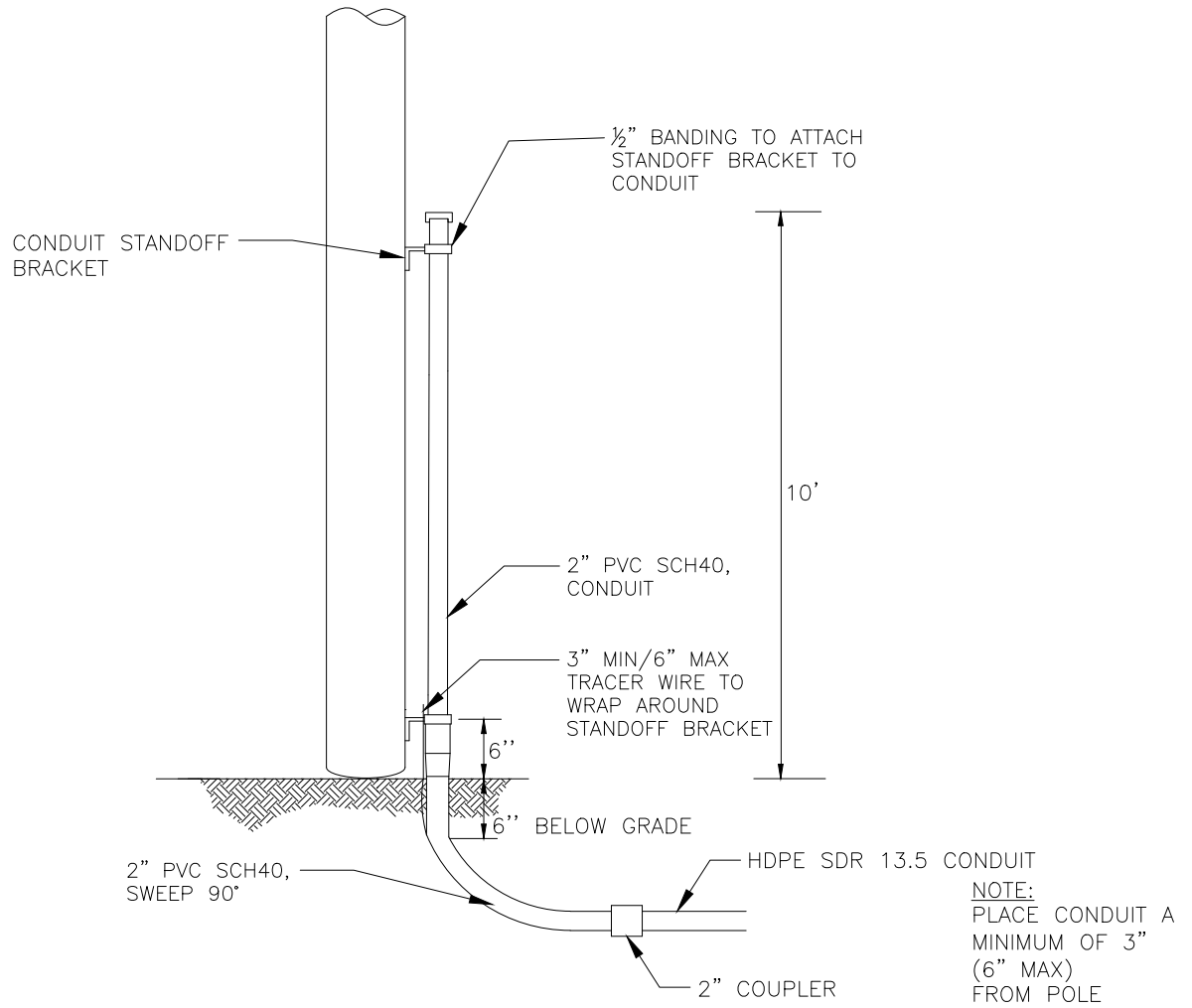

DESCRIPTION	QTY	MANUFACTURER (PREFERRED)	PART #
SCREW, LAG, 1/2" x 4-1/2"	10		
HDPE SDR 13.5 CONDUIT, VARIOUS SIZES	N/A		
2" PVC SCH40, RISER PIPE	1		
#12 TRACER WIRE	N/A		
2" PVC SCH40, SWEEP, 90 DEG	1		
CONDUIT STANDOFF BRACKET	VARIES		
CONDUIT STRAP KIT	VARIES		
2" COUPLER	1		



TYPICAL RISER
CONDUIT
WOOD POLE

(R2-W)

CONCEPTUAL SIDE VIEW

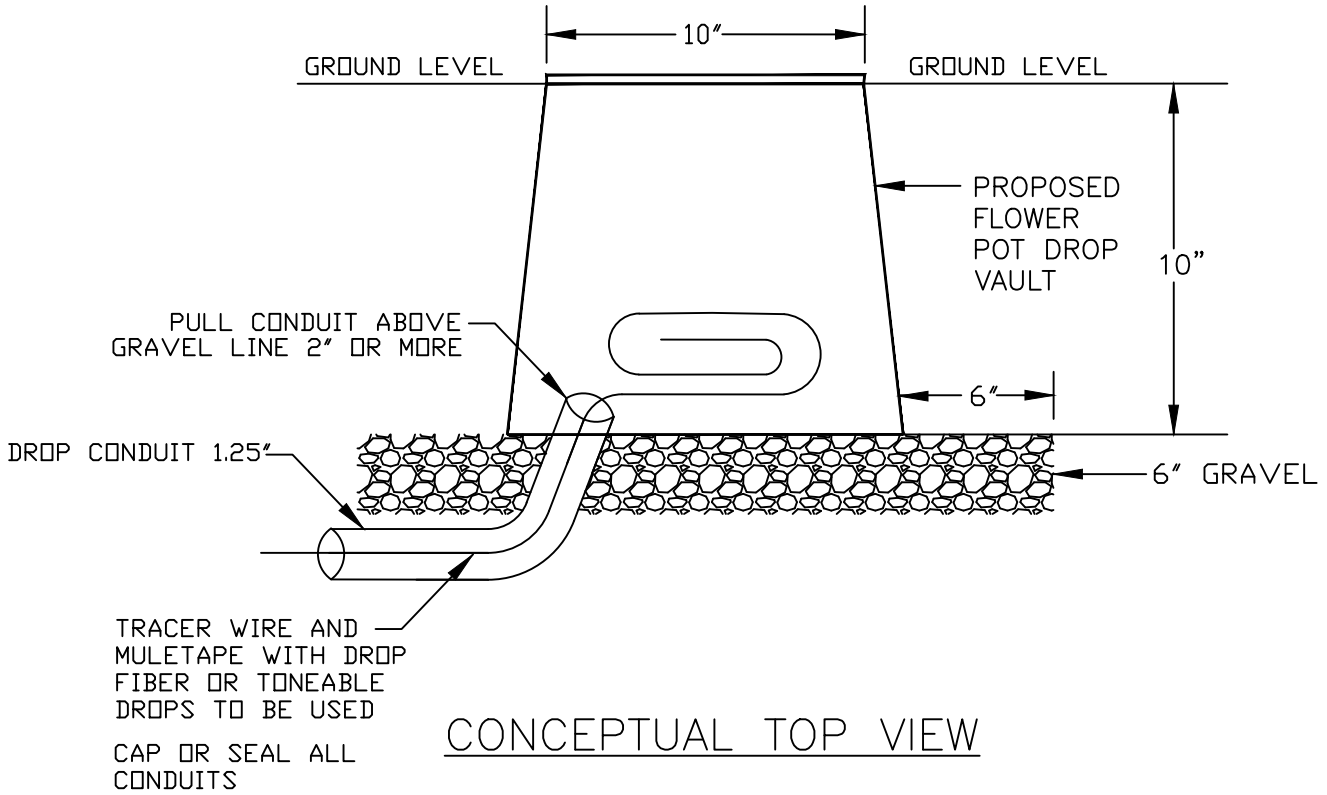

CONCEPTUAL TOP VIEW

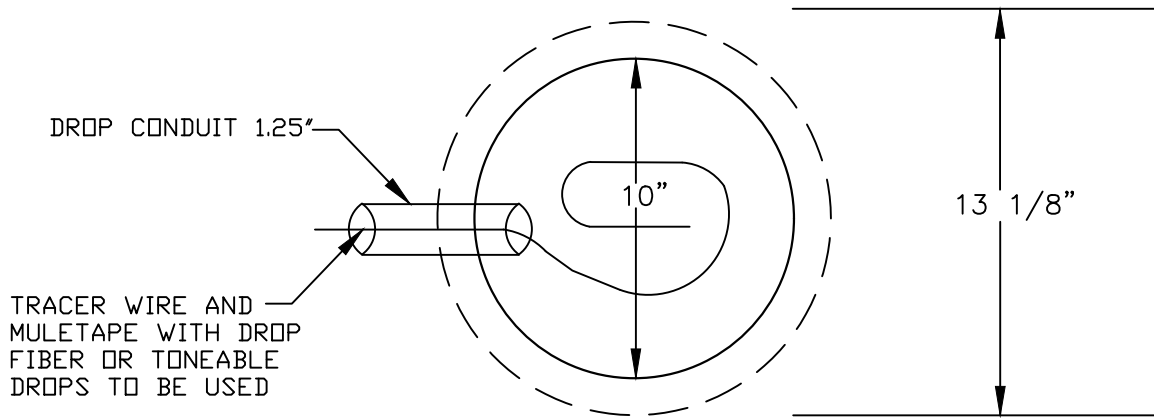

FLOWER POT

30"x48" PC UNIT, 2PC TIER 15/22
 18", 24", and 36" HEIGHT



AMERICAN POLYMER COMPANY

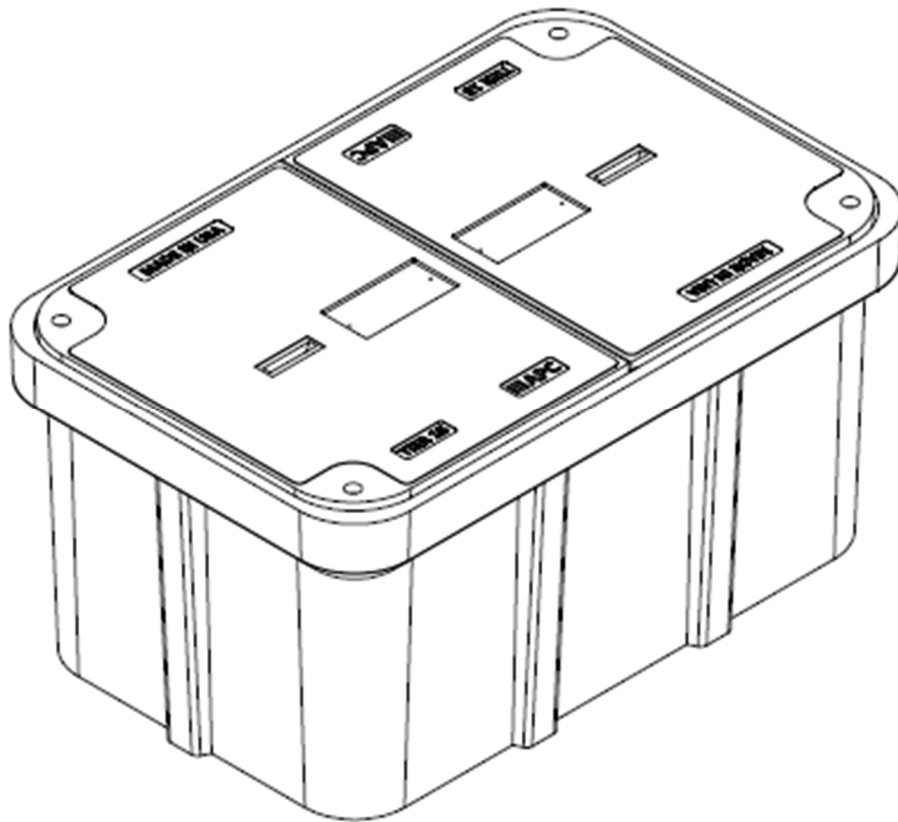

Description	Nominal Size	ANSI Tier	Part Number	Estimated Weight
PC Unit – TIER 15	30"x48"x18"	Tier 15	P304818HU15...	460 lbs.
PC Unit – TIER 22	30"x48"x18"	Tier 22	P304818HU22...	525 lbs.
PC Unit – TIER 15	30"x48"x24"	Tier 15	P304824HU15...	510 lbs.
PC Unit – TIER 22	30"x48"x24"	Tier 22	P304824HU22...	575 lbs.
PC Unit – TIER 15	30"x48"x36"	Tier 15	P304836HU15...	615 lbs.
PC Unit – TIER 22	30"x48"x36"	Tier 22	P304836HU22...	680 lbs.



30"x48" PC UNIT, 2PC TIER 15/22

18", 24", and 36" HEIGHT



AMERICAN POLYMER COMPANY

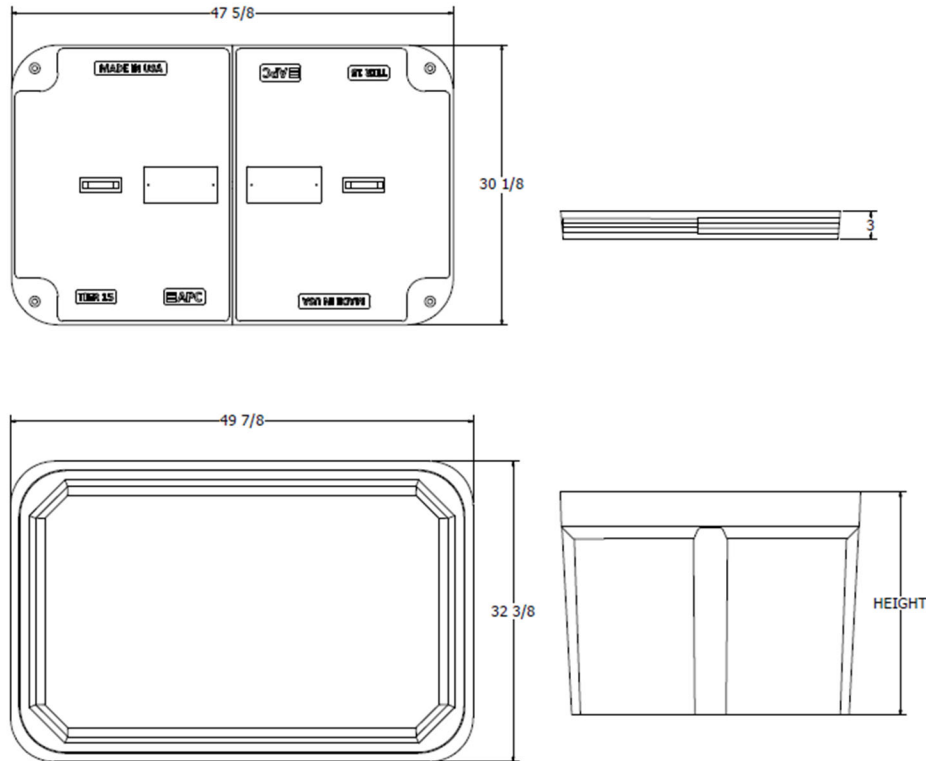

Components	Nominal Size	ANSI Tier	Part Number	Estimated Weight
Replacement Box	30"x48"x18"	Tier 22	P304818B22	185 lbs.
Replacement Box	30"x48"x24"	Tier 22	P304824B22	235 lbs.
Replacement Box	30"x48"x36"	Tier 22	P304836B22	340 lbs.
Replacement Lids - T15	30"x48" (half)	Tier 15	Various	150 lbs.
Replacement Lids - T22	30"x48" (half)	Tier 22	Various	170 lbs.

Bolt options



Machine Thread



Auger Thread



24"x36" PC UNIT, TIER 15/22
 18", 24", 30", and 36" HEIGHT



AMERICAN POLYMER COMPANY

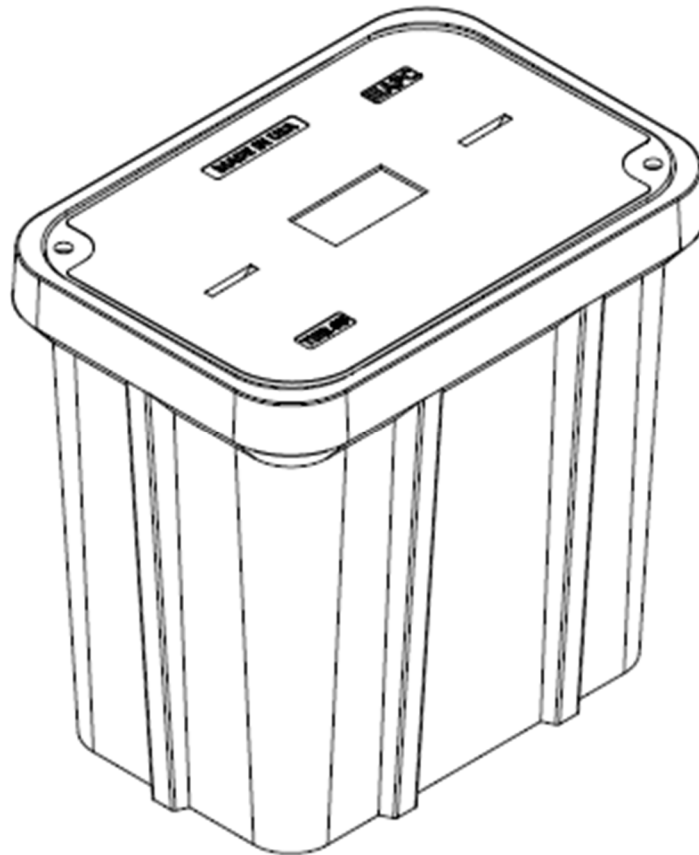

Description	Nominal Size	ANSI Tier	Part Number	Estimated Weight
PC Unit – TIER 15	24x36"x18"	Tier 15	P243618U15...	335 lbs.
PC Unit – TIER 22	24x36"x18"	Tier 22	P243618U22...	355 lbs.
PC Unit – TIER 15	24x36"x24"	Tier 15	P243624U15...	365 lbs.
PC Unit – TIER 22	24x36"x24"	Tier 22	P243624U22...	385 lbs.
PC Unit – TIER 15	24x36"x30"	Tier 15	P243630U15...	395 lbs.
PC Unit – TIER 22	24x36"x30"	Tier 22	P243630U22...	415 lbs.
PC Unit – TIER 15	24x36"x36"	Tier 15	P243636U15...	425 lbs.
PC Unit – TIER 22	24x36"x36"	Tier 22	P243636U22...	445 lbs.



24"x36" PC UNIT, TIER 15/22

18", 24", 30", and 36" HEIGHT



AMERICAN POLYMER COMPANY

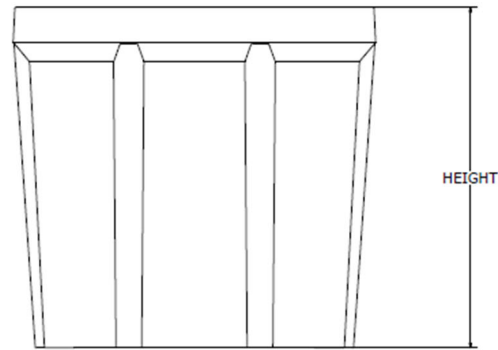
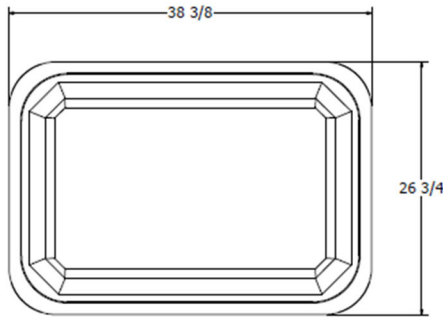
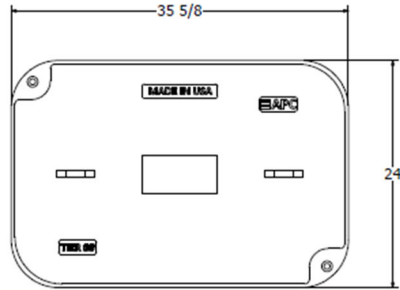

Components	Nominal Size	ANSI Tier	Part Number	Estimated Weight
Replacement Box	24"x36"x18"	Tier 22	P243618B22	165 lbs.
Replacement Box	24"x36"x24"	Tier 22	P243624B22	195 lbs.
Replacement Box	24"x36"x30"	Tier 22	P243630B22	225 lbs.
Replacement Box	24"x36"x36"	Tier 22	P243636B22	255 lbs.
Replacement Lids - T15	24"x36"	Tier 15	Various	170 lbs.
Replacement Lids - T22	24"x36"	Tier 22	Various	190 lbs.

Bolt options

Hex Head



Machine Thread



Penta Head



Auger Thread



17"x30" PC UNIT, TIER 15/22

12", 18", 24", and 30" HEIGHT



AMERICAN POLYMER COMPANY

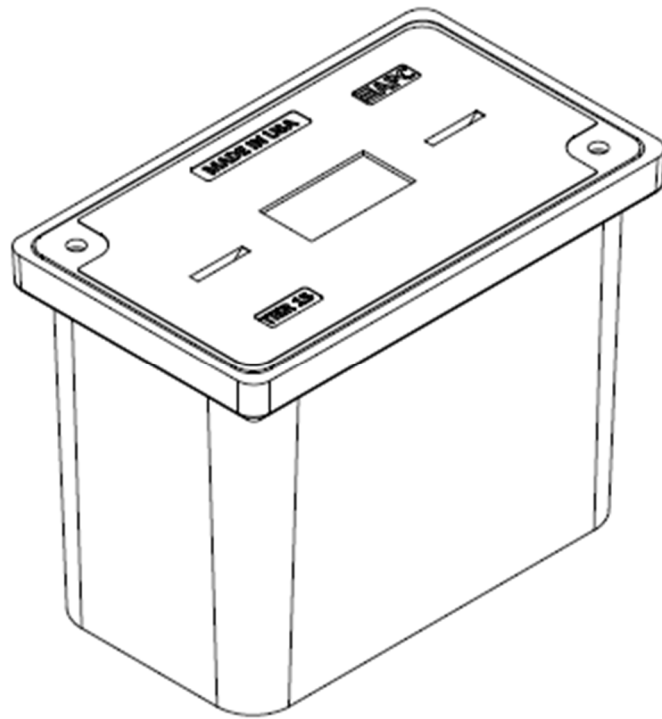

Description	Nominal Size	ANSI Tier	Part Number	Estimated Weight
PC Unit – TIER 15	17"x30"x12"	Tier 15	P173012U15...	138 lbs.
PC Unit – TIER 22	17"x30"x12"	Tier 22	P173012U22...	147 lbs.
PC Unit – TIER 15	17"x30"x18"	Tier 15	P173018U15...	172 lbs.
PC Unit – TIER 22	17"x30"x18"	Tier 22	P173018U22...	181 lbs.
PC Unit – TIER 15	17"x30"x24"	Tier 15	P173024U15...	192 lbs.
PC Unit – TIER 22	17"x30"x24"	Tier 22	P173024U22...	201 lbs.
PC Unit – TIER 15	17"x30"x30"	Tier 15	P173030U15...	217 lbs.
PC Unit – TIER 22	17"x30"x30"	Tier 22	P173030U22...	226 lbs.



17"x30" PC UNIT, TIER 15/22

12", 18", 24", and 30" HEIGHT



AMERICAN POLYMER COMPANY

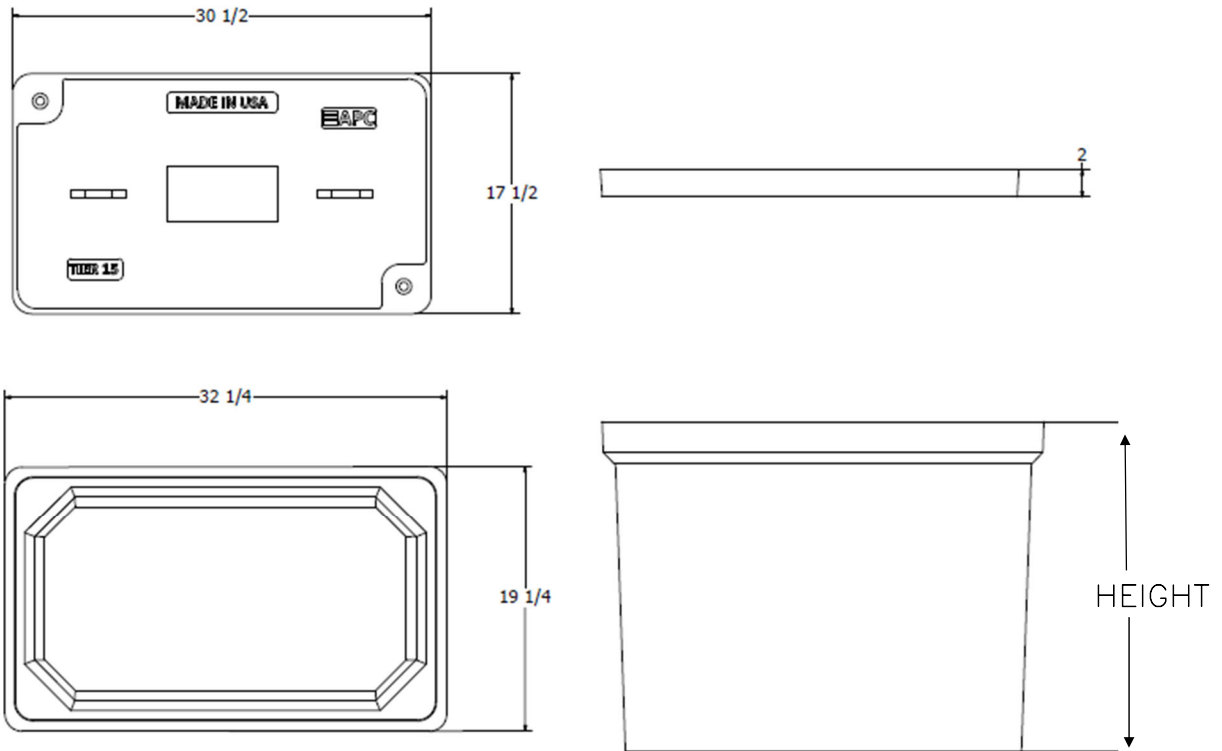

Components	Nominal Size	ANSI Tier	Part Number	Estimated Weight
Replacement Box	17"x30"X12"	Tier 22	P173012B22	66 lbs.
Replacement Box	17"x30"X18"	Tier 22	P173018B22	100 lbs.
Replacement Box	17"x30"X24"	Tier 22	P173024B22	120 lbs.
Replacement Box	17"x30"X30"	Tier 22	P173030B22	145 lbs.
Replacement Lids – T15	17"x30"	Tier 15	Various	72 lbs.
Replacement Lids – T22	17"x30"	Tier 22	Various	81 lbs.

Bolt options



Machine Thread



Auger Thread



33"x60" PC UNIT, 2PC TIER 15/22
36" HEIGHT



AMERICAN POLYMER COMPANY

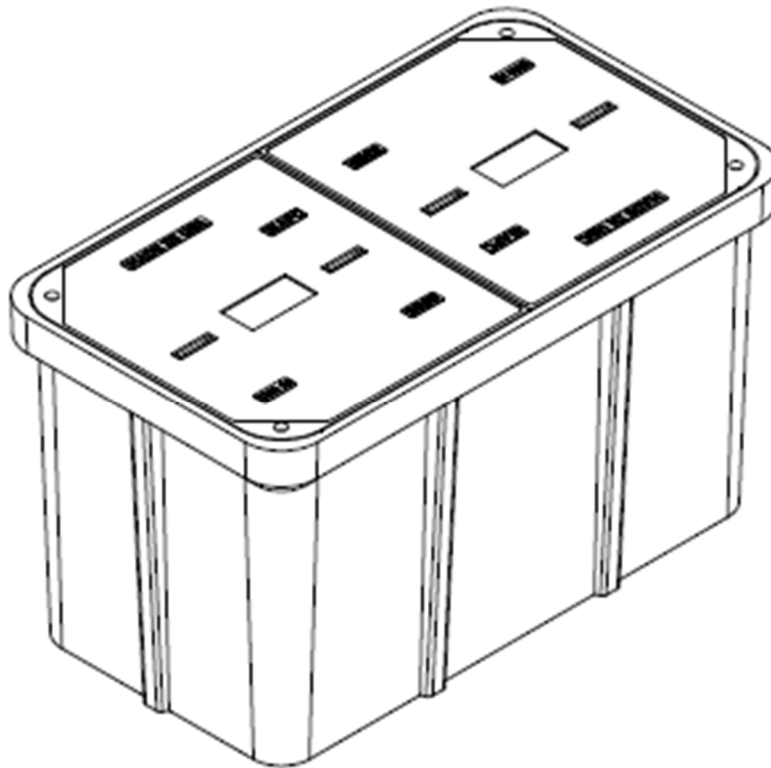

Description	Nominal Size	ANSI Tier	Part Number	Estimated Weight
PC Unit - TIER 15	33"x60"x36"	Tier 15	P336036U15...	930 lbs.
PC Unit - TIER 22	33"x60"x36"	Tier 22	P336036U22...	1030 lbs.



33"x60" PC UNIT, 2PC TIER 15/22

36" HEIGHT



AMERICAN POLYMER COMPANY

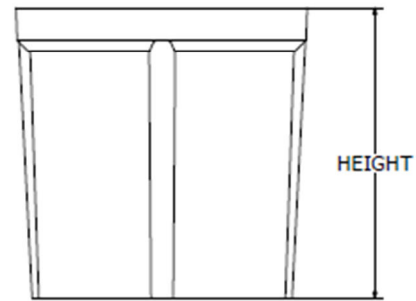
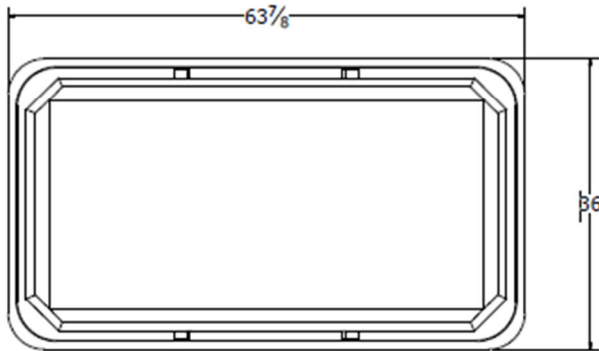
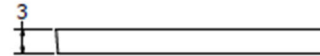

Components	Nominal Size	ANSI Tier	Part Number	Estimated Weight
Replacement Box	33"x60"x36"	Tier 22	P336036B22	530 lbs.
Replacement Lids - T15	33"x60" (half)	Tier 15	Various	200 lbs.
Replacement Lids - T22	33"x60" (half)	Tier 22	Various	250 lbs.

Bolt options

Hex Head



Machine Thread



Penta Head



Auger Thread



Speed (MPH) Prior To Road Work	SIGN SPACING, FT.		BUFFER SPACE, FT.	TAPER LENGTH, FT.		CHANNELIZING SPACING, FT.	
	Non-Divided Highways	Divided Highways	Length	Shoulder (10 ft. Width)	Lane (12 ft. Width)	Through Taper	Through Buffer/Work Area
	0-35	200	200	250	70	245	35
40-45	350	500	360	150	540	40	80
50-55	500	1000	495	185	660	50	100
60-70	SA-1000, SB-1500, SC-2640		730	235	840	60	120
Urban Low Speed - 100 FT							

APPROVED/ACCEPTED BY:
ENGINEER, OWNER, or PRIME CONTRACTOR
 Check for Notice to Proceed.
BLC02a-F14_S Maxwell St -TCP1

Signature: _____

Company: _____



Date: 1/18/2023 Project: BLC02a-F14 S Maxwell St -TCP :
: Traffic Control Suggestion For: AEG :
By: Road Runner Safety Services, Inc. : Nathan

Comments:
Drawing not to scale. Traffic control plan must be approved by an engineer. This is a suggestion only. Road Runners Safety Services, Inc. has no liability for this suggested traffic control plan. Actual placement and spacing of all traffic control devices will depend on field conditions and must conform to MUTCD standards.

- Legend**
- ADA Barricade
 - Channelizer
 - Conduit
 - Flagger (Person)
 - Overhead Strand
 - Sign
 - Vault
 - Work Area

Sheet 1

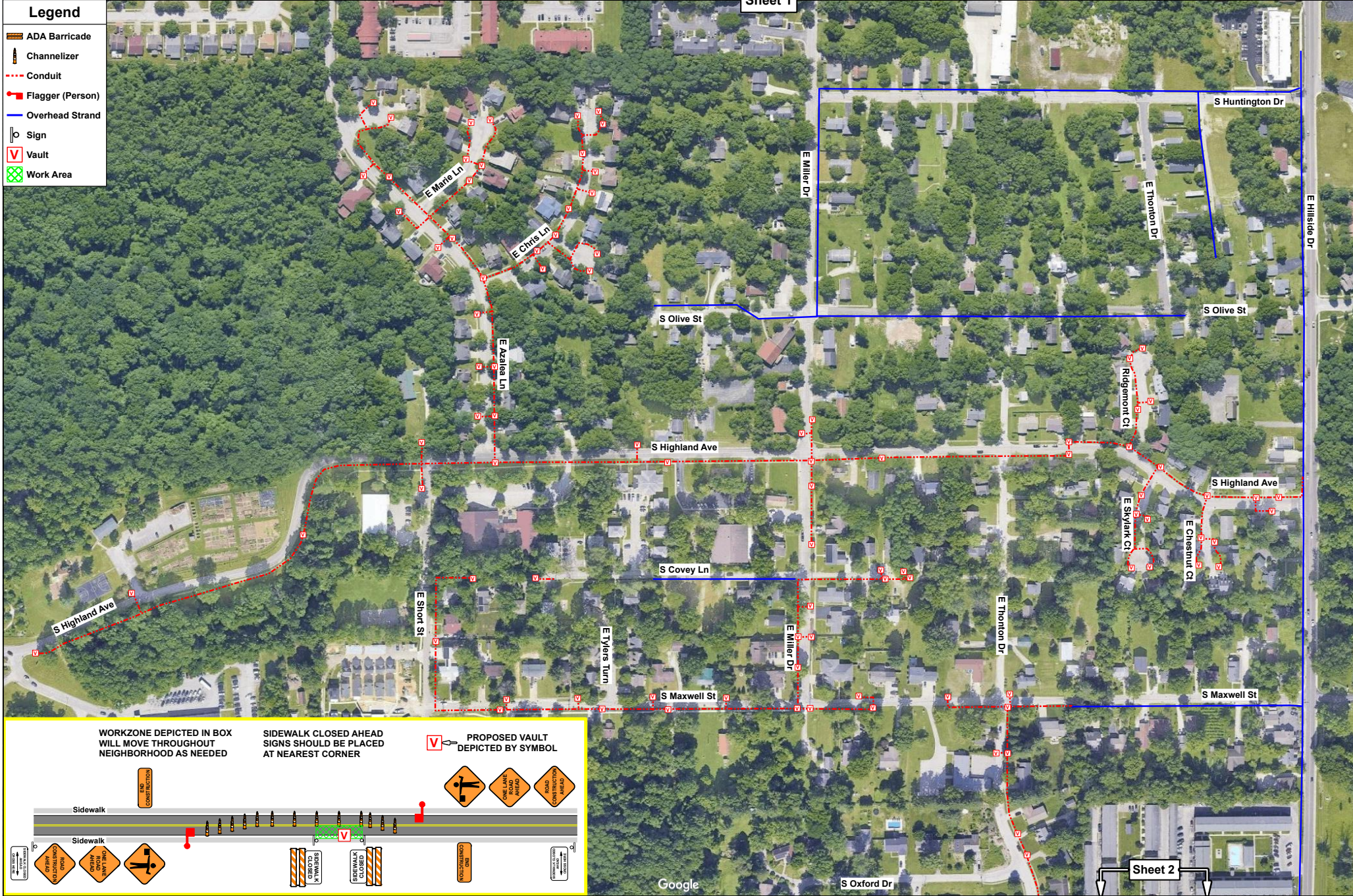

Sheet 2

Speed (MPH) Prior To Road Work	SIGN SPACING, FT.		BUFFER SPACE, FT.	TAPER LENGTH, FT.		CHANNELIZING SPACING, FT.	
	Non-Divided Highways	Divided Highways	Length	Shoulder (10 ft. Width)	Lane (12 ft. Width)	Through Taper	Through Buffer/Work Area
	0-35	200	200	250	70	245	35
40-45	350	500	360	150	540	40	80
50-55	500	1000	495	185	660	50	100
60-70	SA-1000, SB-1500, SC-2640		730	235	840	60	120
	Urban Low Speed - 100 FT						

APPROVED/ACCEPTED BY:
ENGINEER, OWNER, or PRIME CONTRACTOR
 Check for Notice to Proceed.
BLC02a-F14_S Maxwell St -TCP2

Signature: _____

Company: _____



Date: 1/18/2023 Project: BLC02a-F14 S Maxwell St -TCP :
Traffic Control Suggestion For: AEG :
By: Road Runner Safety Services, Inc. : Nathan

Comments:
Drawing not to scale. Traffic control plan must be approved by an engineer. This is a suggestion only. Road Runners Safety Services, Inc. has no liability for this suggested traffic control plan. Actual placement and spacing of all traffic control devices will depend on field conditions and must conform to MUTCD standards.

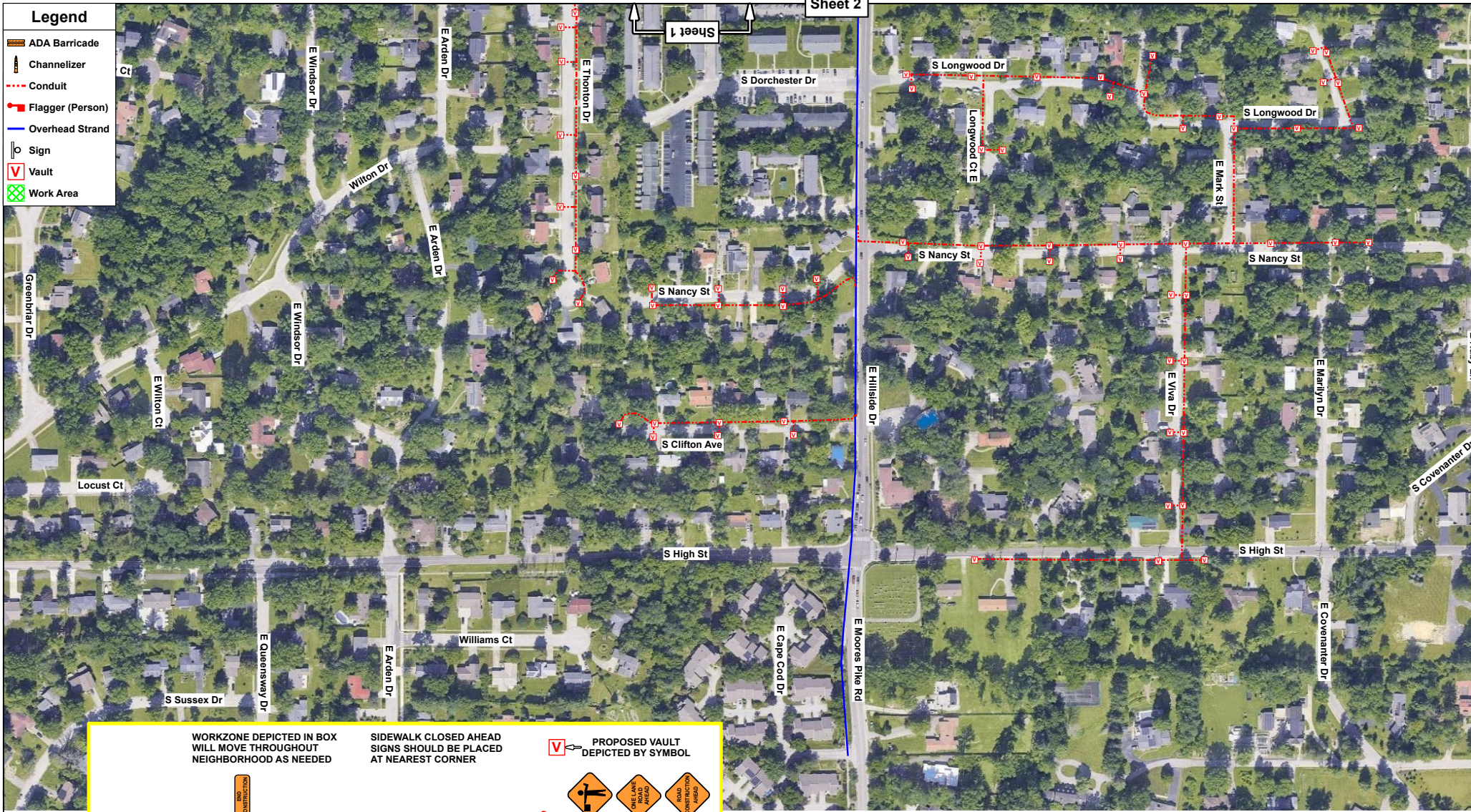

Sheet 2

- Legend**
- ADA Barricade
 - Channelizer
 - Conduit
 - Flagger (Person)
 - Overhead Strand
 - Sign
 - Vault
 - Work Area

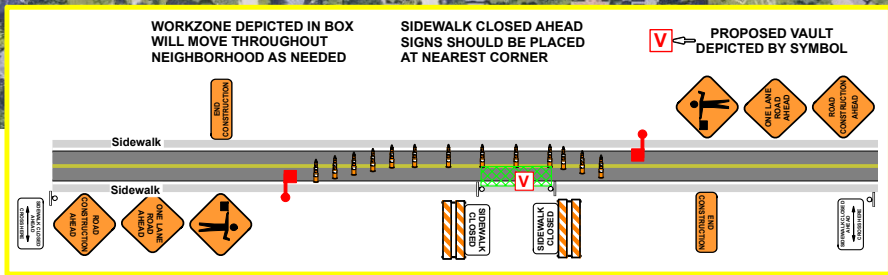

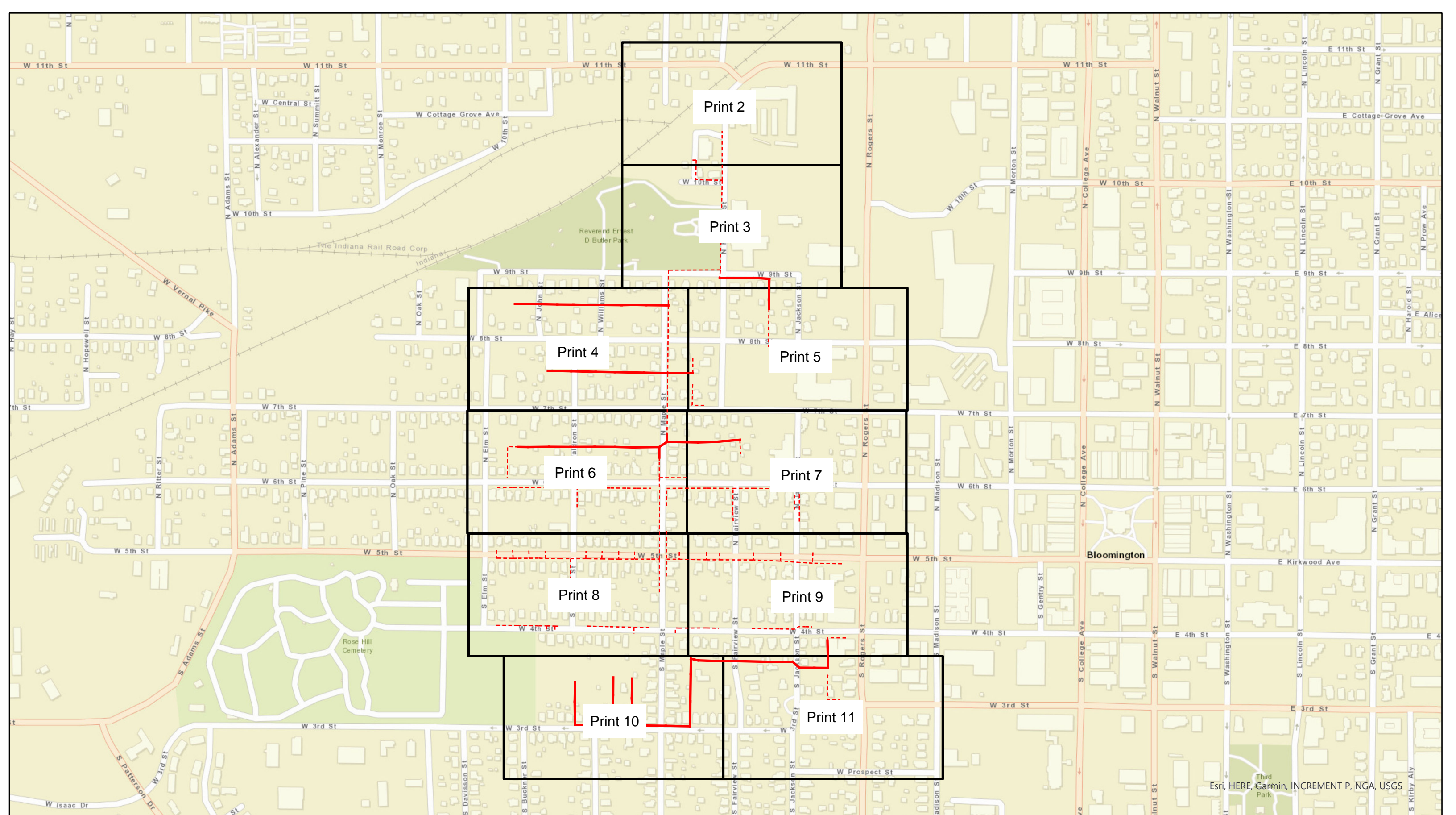

Esri, HERE, Garmin, INCREMENT P, NGA, USGS



Legend BLN01b-F11_N Williams St

- Overhead Strand
- - - Conduit
- Grids

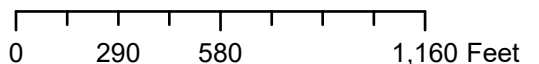

City of Bloomington, IN Permit:
Design View

INI	BY	DATE	DESCRIPTION



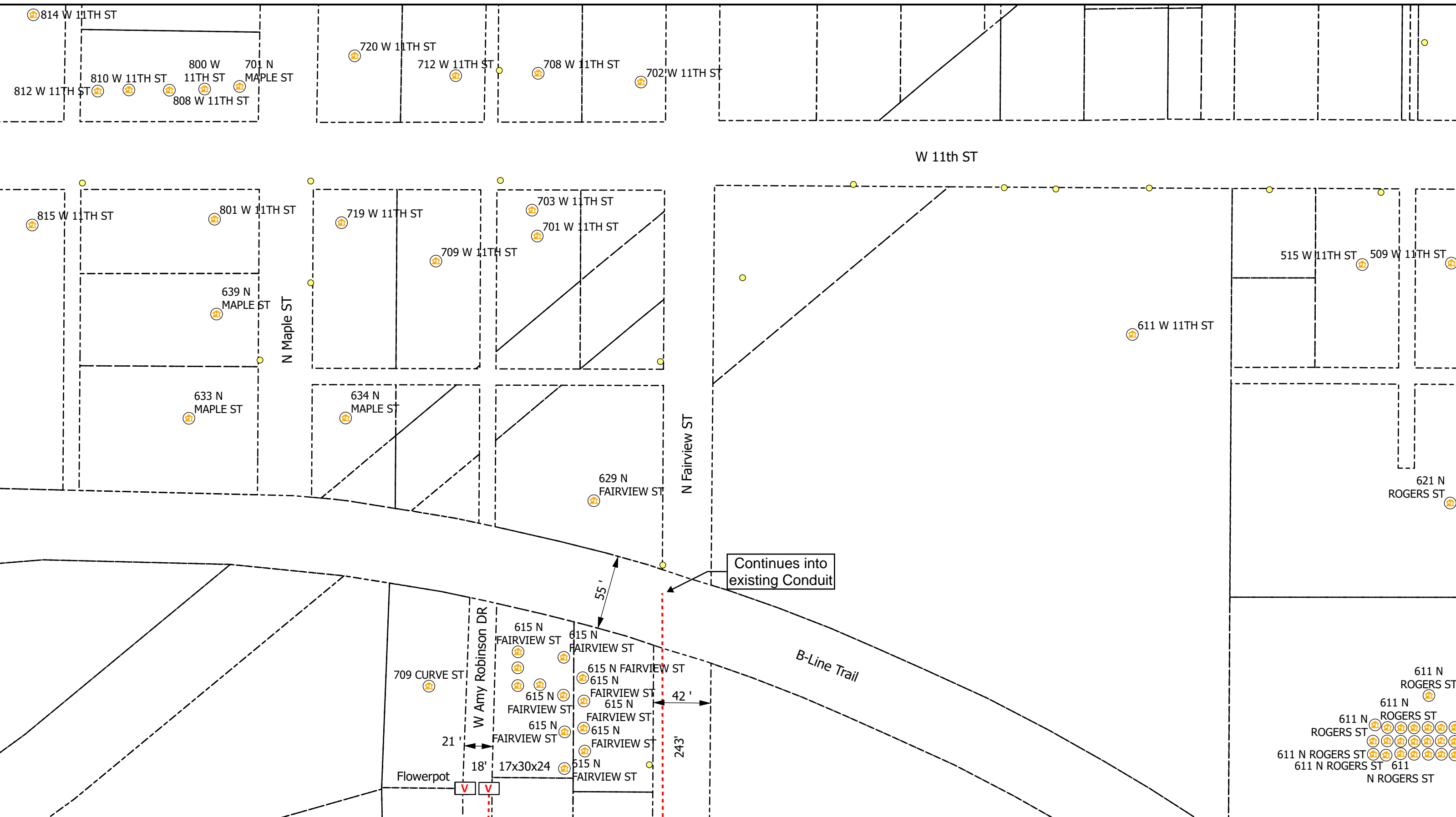

- Legend**
- Poles
 - Risers
 - Sidewalk
 - Vaults
 - Address
 - Anchor
 - Overhead Strand
 - Conduit
 - Bloomington_Parcels
 - Grids

All Flowerpots 12" DIA



City of Bloomington, IN Permit:
Design View

INI	BY	DATE	DESCRIPTION



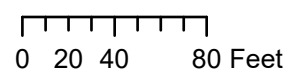
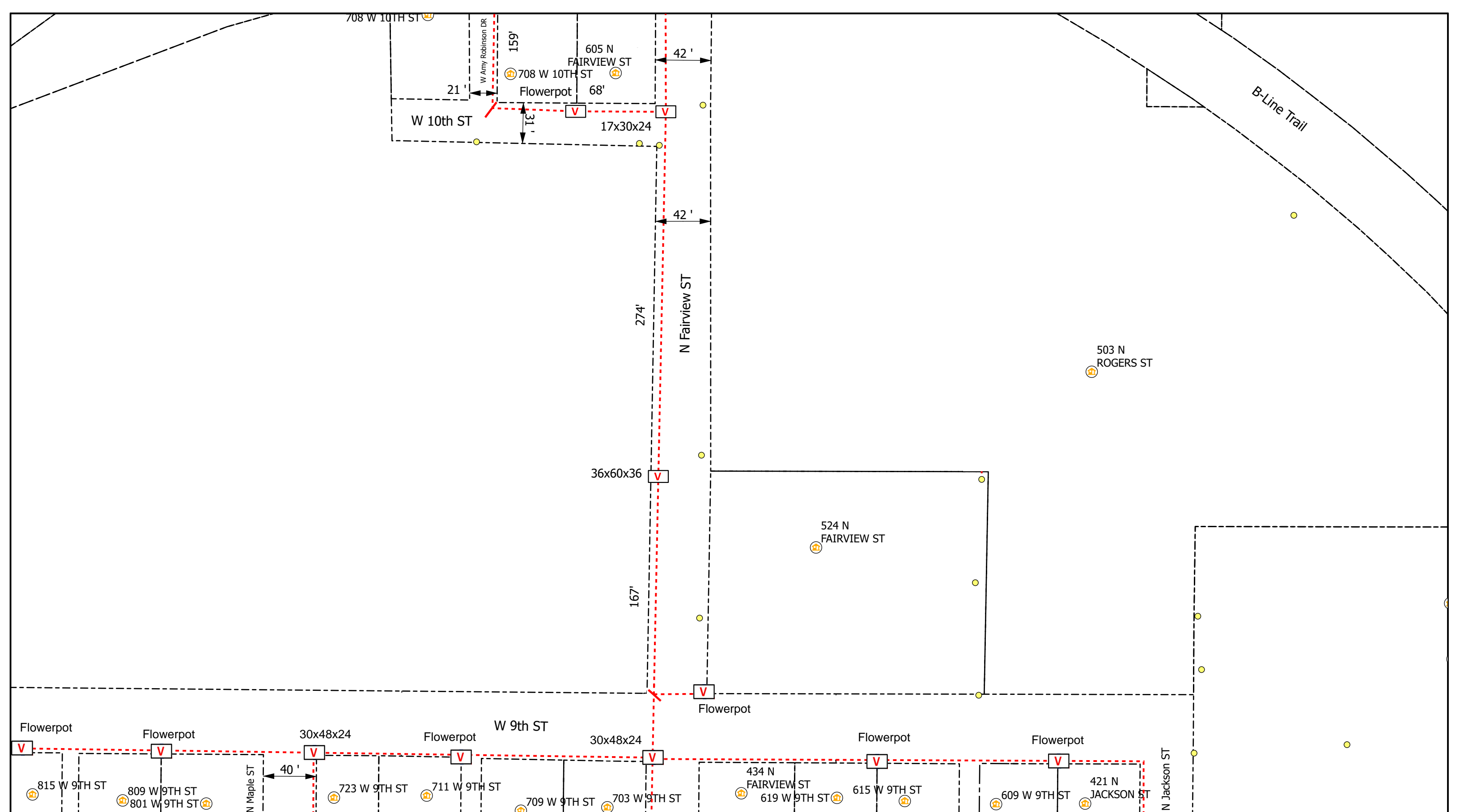

Legend

- Poles
- V Vaults
- Overhead Strand
- Conduit
- R Risers
- A Address
- Y Anchor
- ↖ Sidewalk
- Bloomington_Parcels
- Grids

All Flowerpots 12" DIA



City of Bloomington, IN Permit:
Design View

INI	BY	DATE	DESCRIPTION



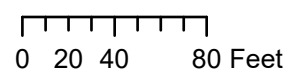
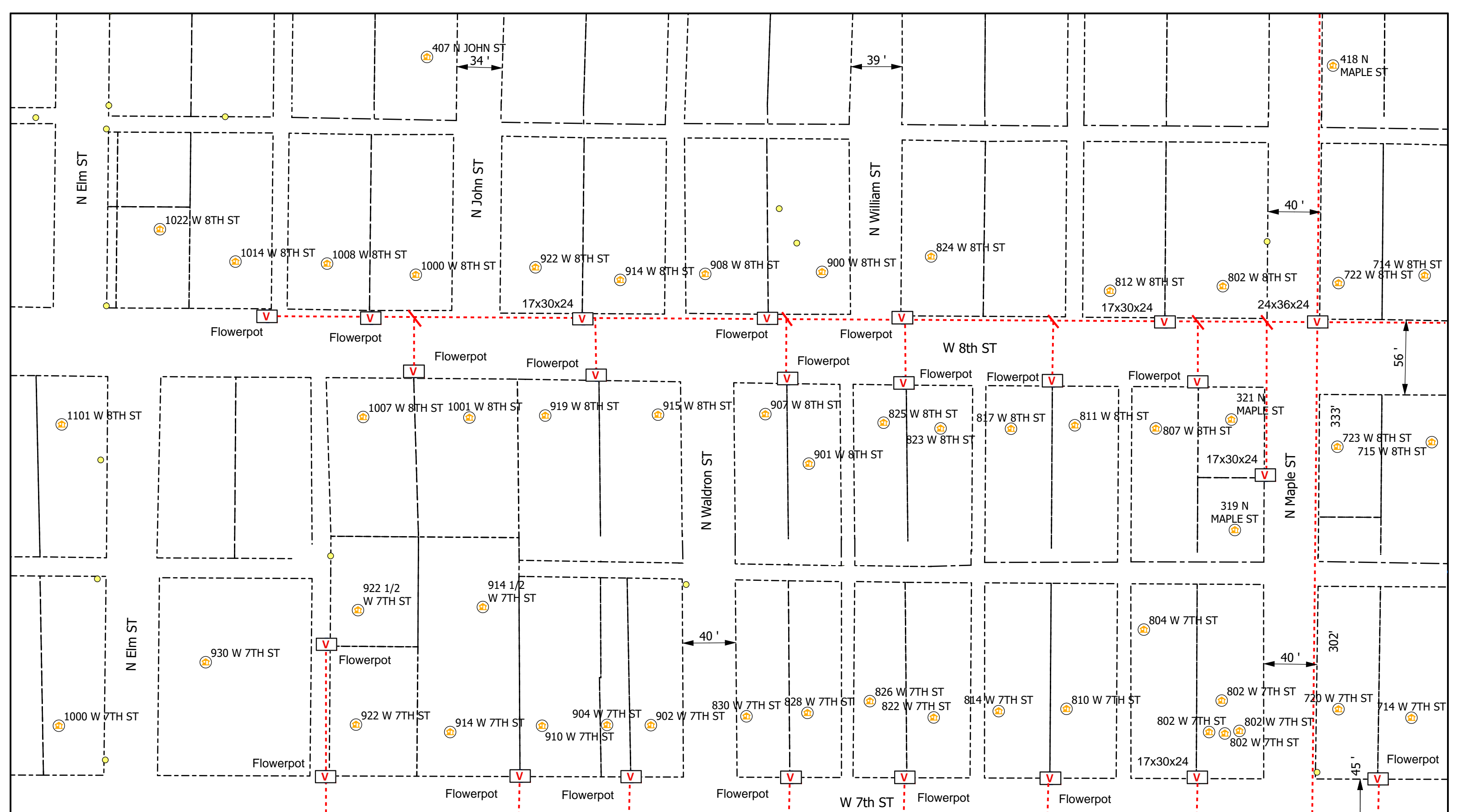

Legend

- Poles
- Risers
- Address
- Anchor
- Vaults
- Overhead Strand
- Conduit
- Sidewalk
- Bloomington_Parcels
- Grids

All Flowerpots 12" DIA



City of Bloomington, IN Permit:
Design View

INI	BY	DATE	DESCRIPTION



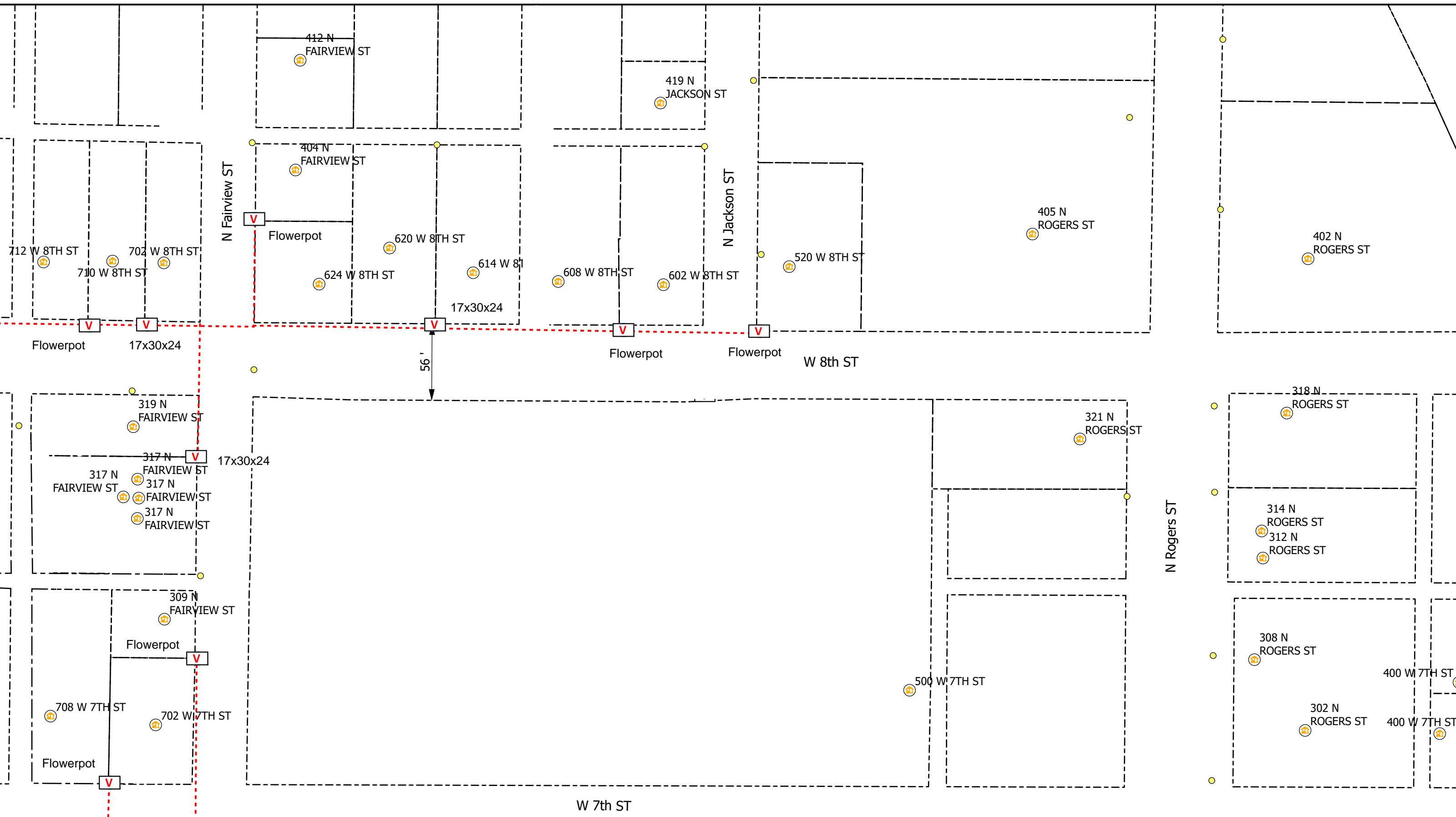

Legend

- Poles
- Risers
- Sidewalk
- Vaults
- Address
- Bloomington_Parcels
- Overhead Strand
- Anchor
- Conduit
- Grids

All Flowerpots 12" DIA



City of Bloomington, IN Permit:
Design View

INI	BY	DATE	DESCRIPTION



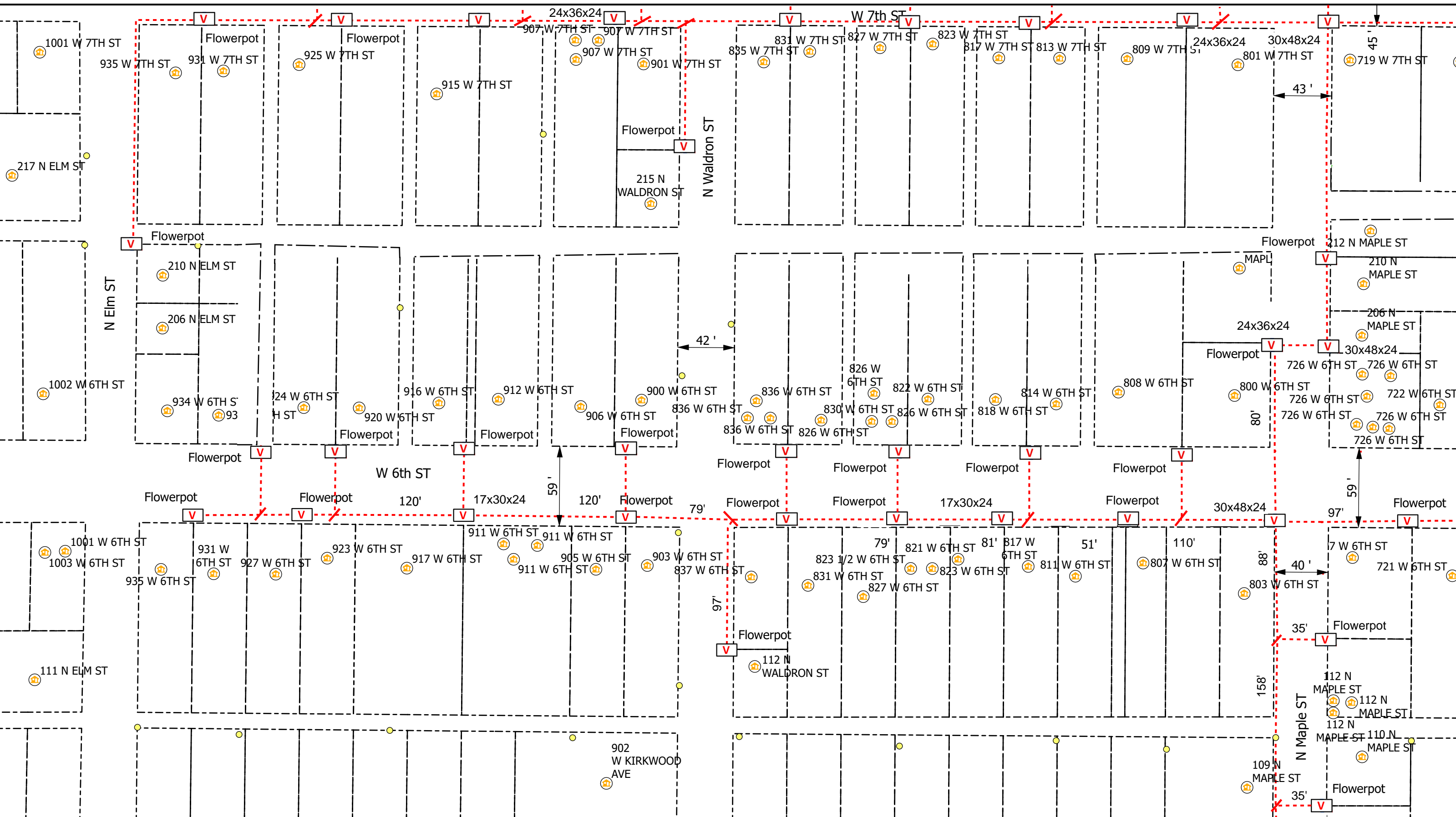

Legend

- Poles
- V Vaults
- Overhead Strand
- - - Conduit
- R Risers
- Ⓜ Address
- Y Anchor
- ↖ Sidewalk
- Bloomington_Parcels
- Grids

All Flowerpots 12" DIA



City of Bloomington, IN Permit:
Design View

INI	BY	DATE	DESCRIPTION



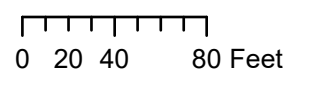
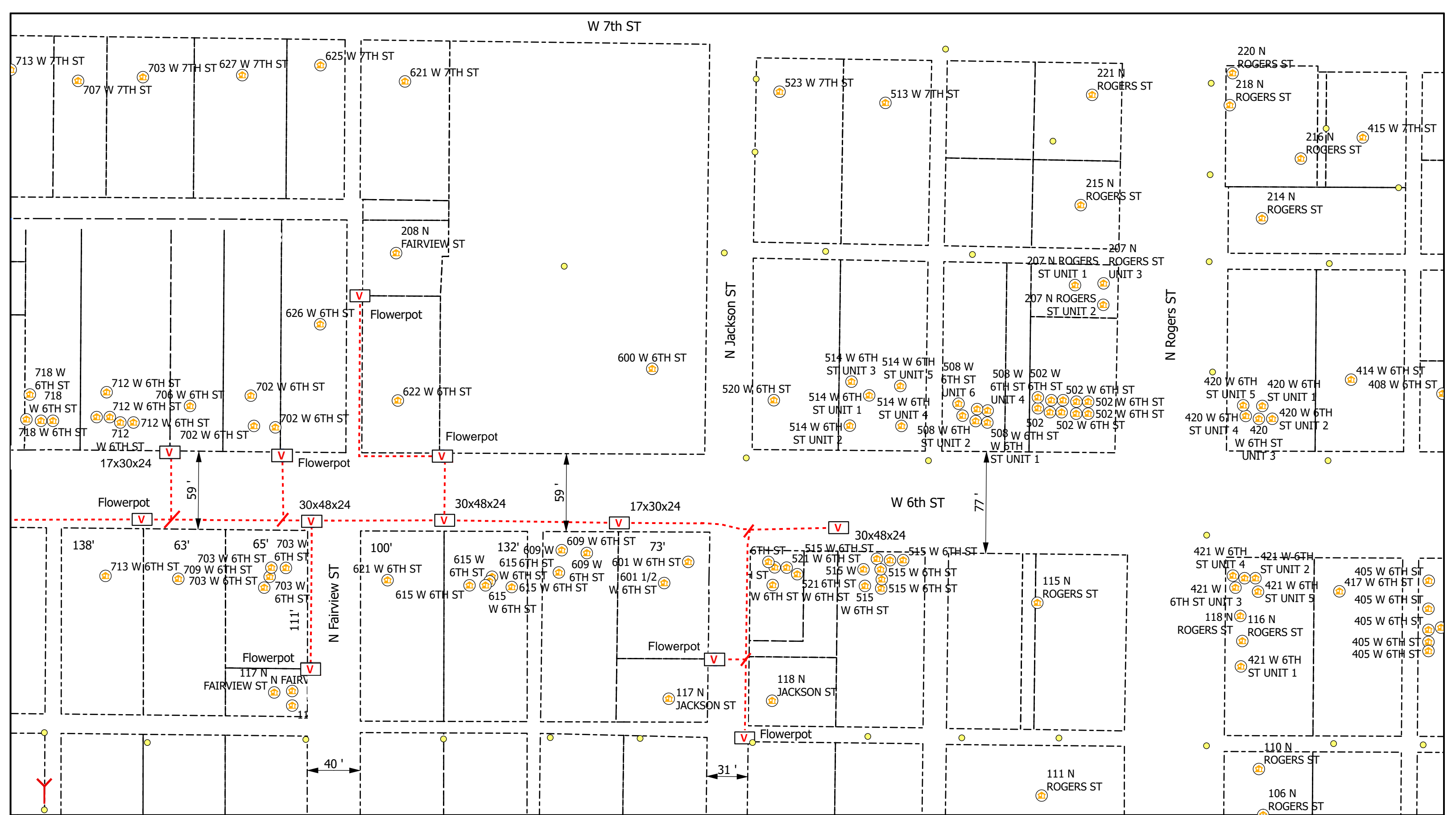

Legend

- Poles
- V Vaults
- Overhead Strand
- Conduit
- Ⓡ Risers
- Ⓜ Address
- Y Anchor
- ↖ Sidewalk
- Bloomington_Parcels
- Grids

All Flowerpots 12" DIA



City of Bloomington, IN Permit:
Design View

INI	BY	DATE	DESCRIPTION



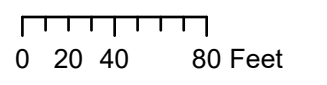
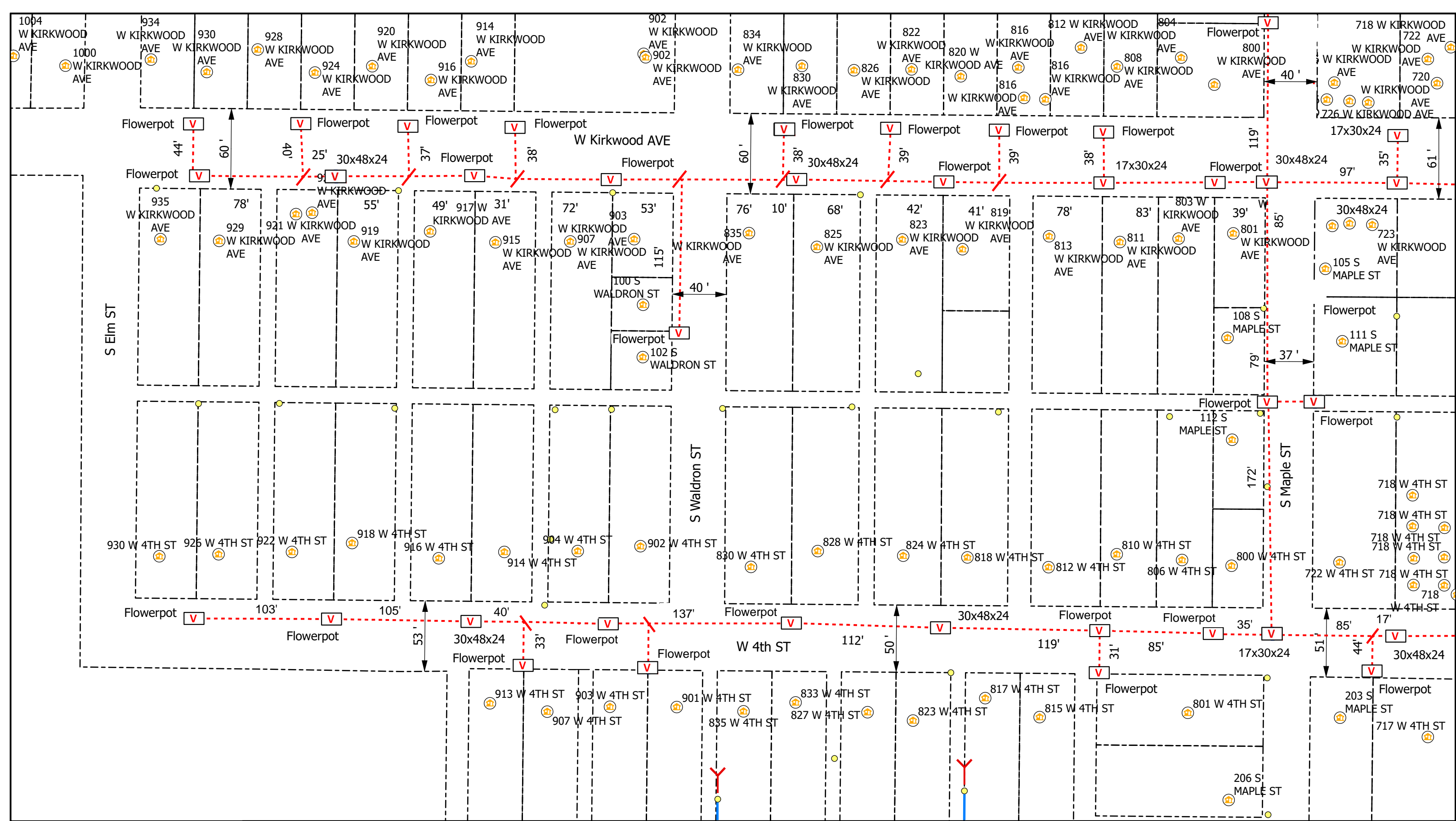

Legend

- Poles
- Ⓡ Risers
- Ⓜ Sidewalk
- V Vaults
- Overhead Strand
- V Conduit
- 🏠 Address
- Y Anchor
- Bloomington_Parcels
- Grids

All Flowerpots 12" DIA



City of Bloomington, IN Permit:
Design View

INI	BY	DATE	DESCRIPTION



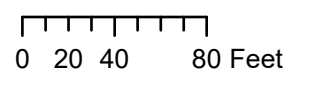
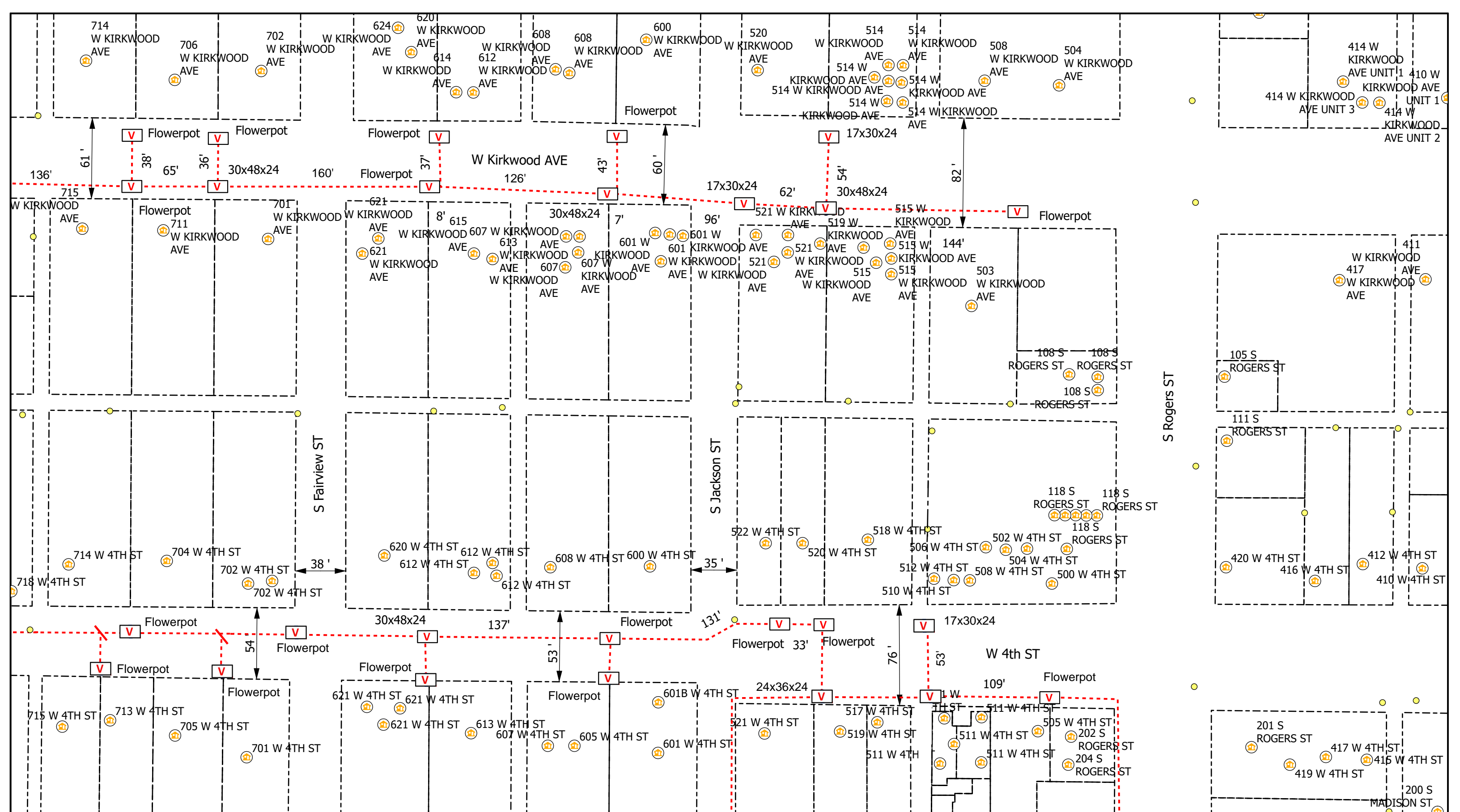

Legend

- Poles
- Vaults
- Overhead Strand
- Conduit
- Risers
- Address
- Anchor
- Sidewalk
- Bloomington_Parcels
- Grids

All Flowerpots 12" DIA



City of Bloomington, IN Permit:
Design View

INI	BY	DATE	DESCRIPTION



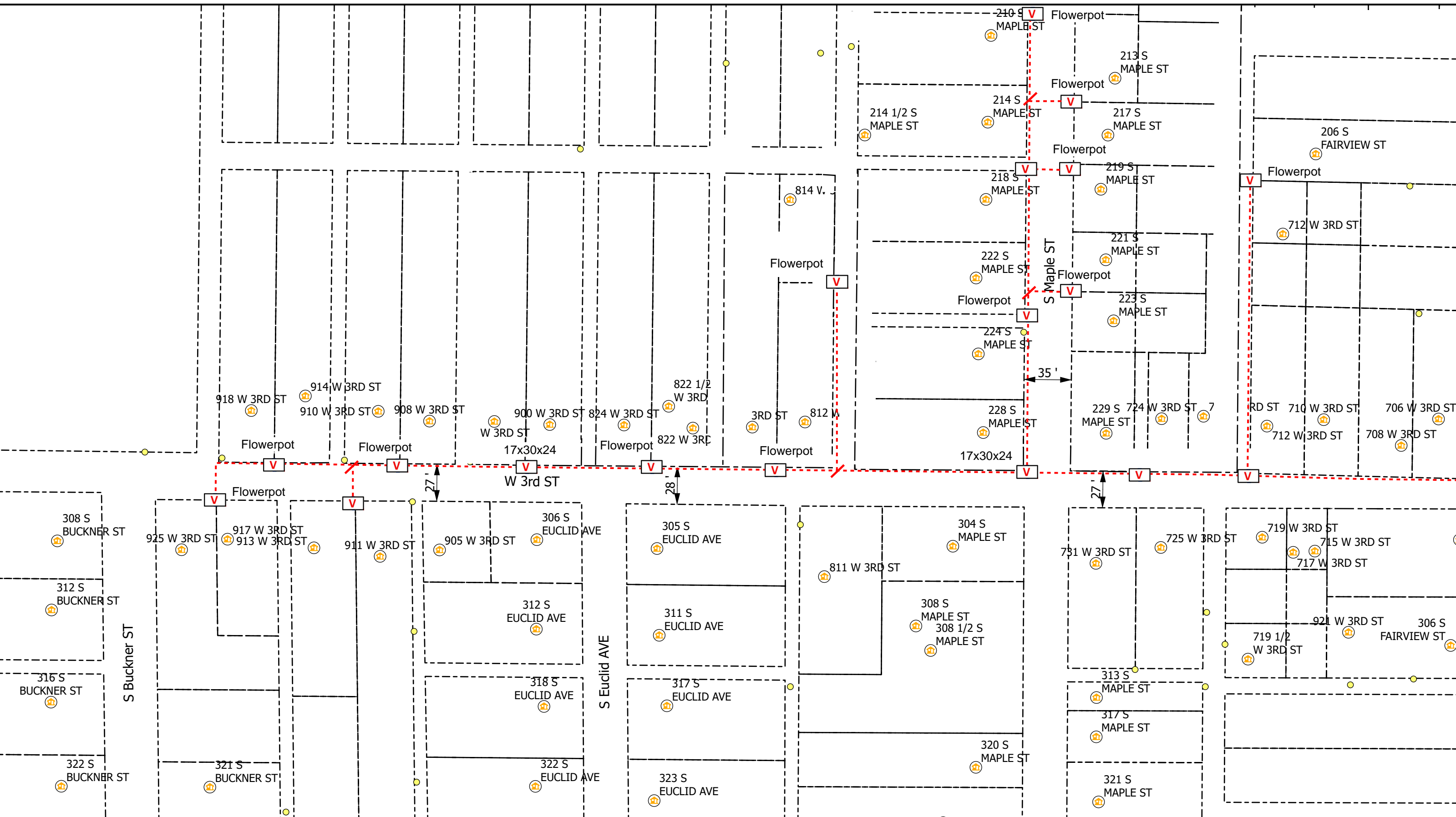

0 20 40 80 Feet

Legend

- Poles
- V Vaults
- Overhead Strand
- Conduit
- R Risers
- A Address
- Y Anchor
- ↖ Sidewalk
- Bloomington_Parcels
- Grids

All Flowerpots 12" DIA



City of Bloomington, IN Permit:
Design View

INI	BY	DATE	DESCRIPTION



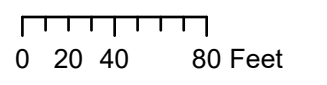
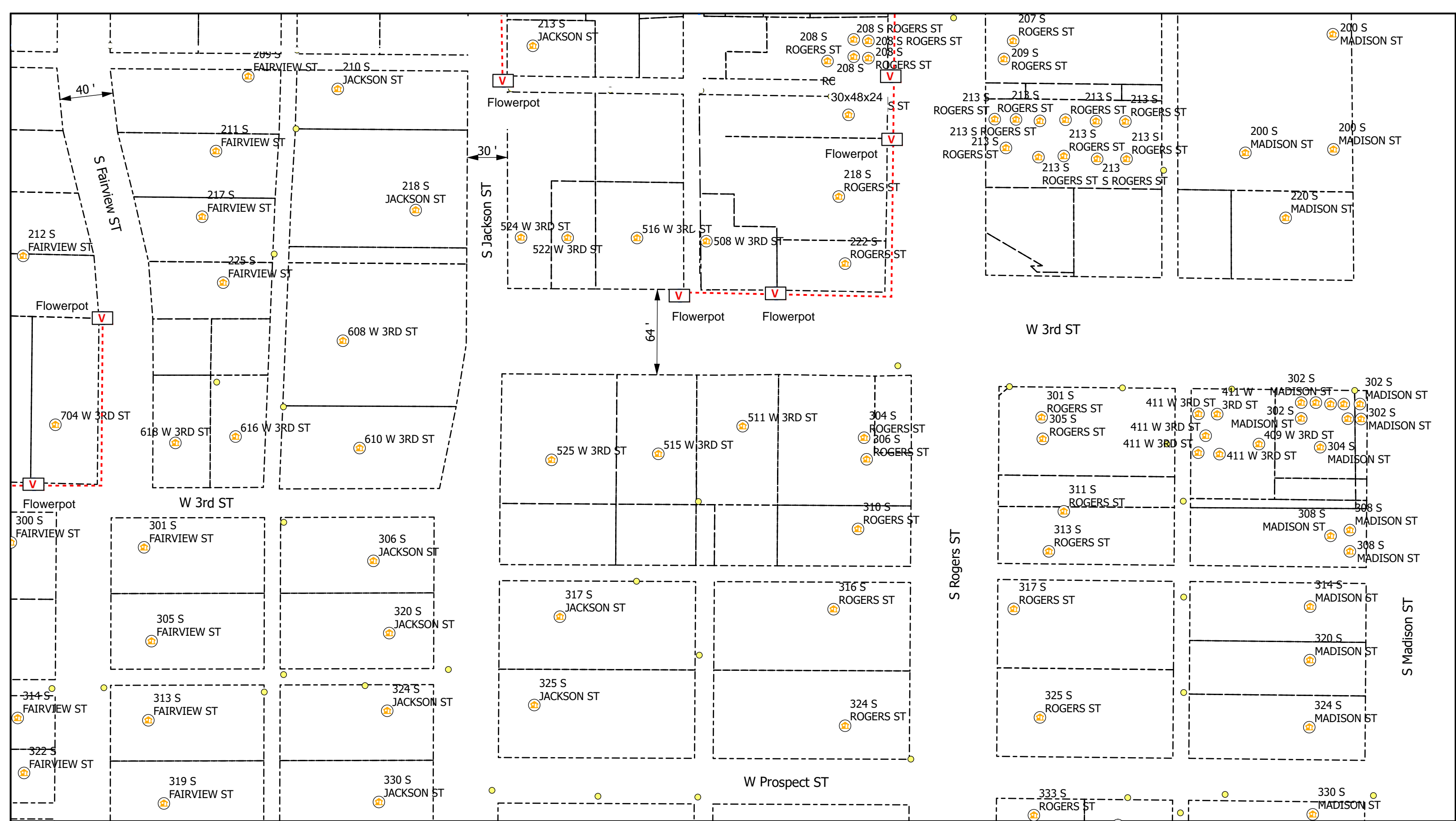

Legend

- Poles
- Ⓡ Risers
- V Vaults
- Overhead Strand
- Conduit
- 🏠 Address
- Y Anchor
- ↶ Sidewalk
- Bloomington_Parcels
- Grids

All Flowerpots 12" DIA



City of Bloomington, IN Permit:
Design View

INI	BY	DATE	DESCRIPTION



Carlton® PV-Mold® Nonmetallic Pole Riser System

Carlton PV-Mold is a nonmetallic pole riser system designed to protect communications power cable installed on poles.

Features:

- Meets or exceeds requirements outlined in the National Electric Safety Code (NESC).
- Designed in accordance with NEMA TC-19 specifications.
- Ultraviolet, cold temperature and corrosive atmosphere resistant.
- Schedule 40 wall meets Schedule 80 PVC conduit impact requirements per NEMA TC-19.
- No grounding required.
- Belled end fits over each added section or conduit.
- Flame retardant.
- Requires no maintenance.
- PV-Mold acts as an insulator against electrical shock.
- Interchangeable parts and accessories to match the needs of specific requirements.



Steel U-Guard requires grounding strapping and does not have belled ends.



PV-Mold has belled ends, flanged design and does not require grounding.

Flanged Overall Length 10 Feet, Including Bell

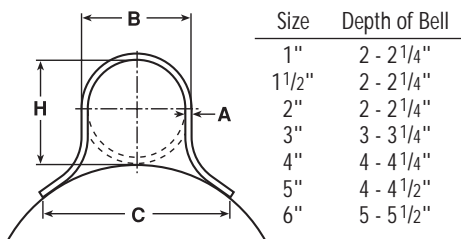

Slots are 1/2" from side to side, and allow for expansion and contraction.

Slot Dimensions: for sizes 2" through 6" are 5/16" wide, 3/4" long.

Slot Dimensions: for 1" and 1 1/2" are 3/16" wide, 3/4" long.

Slot Spacing: 18" from center, beginning 6" from end.

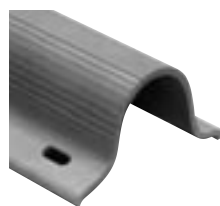

Standard Duty

Part No.	Size	Std. Ctn. Qty.	Std. Ctn. Wt. (lbs.)	Dimensions				Actual Impact @ 0°C 20 Pound Top
				A	B	C	H	
59208N	1"	294	1059	0.100"	1 5/8"	2 3/8"	1 5/8"	40 Ft.-Lbs.
59211N	2"	136	726	0.100"	2 3/8"	4 1/2"	2 3/8"	100 Ft.-Lbs.
59211X (5' length)	2"	136	363	0.100"	2 3/8"	4 1/2"	2 3/8"	100 Ft.-Lbs.
59213N	3"	66	761	0.150"	3 1/2"	6"	3 1/2"	110 Ft.-Lbs.
59213X (5' length)	3"	66	381	0.150"	3 1/2"	6"	3 1/2"	100 Ft.-Lbs.
59215N	4"	65	910	0.150"	4 1/2"	6 1/2"	4 1/2"	110 Ft.-Lbs.
59216N	5"	30	515	0.150"	5 1/2"	7 1/2"	5 1/2"	110 Ft.-Lbs.

Heavy Duty Schedule 40

59010N	1 1/2"	200	1142	0.145"	1 29/32"	3 1/2"	1 29/32"	100 Ft.-Lbs.
59011N	2"	136	1214	0.154"	2 3/8"	4 1/2"	2 3/8"	150 Ft.-Lbs.
59013N	3"	66	937	0.216"	3 1/2"	6"	3 9/32"	150 Ft.-Lbs.
59015N	4"	65	1621	0.237"	4 1/2"	6 1/2"	4 1/2"	260 Ft.-Lbs.
59015X (5' length)	4"	65	707	0.237"	4 1/2"	6 1/2"	4 1/2"	260 Ft.-Lbs.
59016N	5"	30	870	0.258"	5 1/2"	7 1/2"	5 1/2"	260 Ft.-Lbs.
59017N	6"	30	1160	0.280"	6 5/8"	8 3/4"	6 5/8"	260 Ft.-Lbs.

Extra Heavy Duty Schedule 80

59411N	2"	136	1549	0.218"	2 3/8"	4 1/2"	2 3/8"	300 Ft.-Lbs.
59413N	3"	66	1495	0.030"	3 1/2"	6"	3 1/2"	525 Ft.-Lbs.

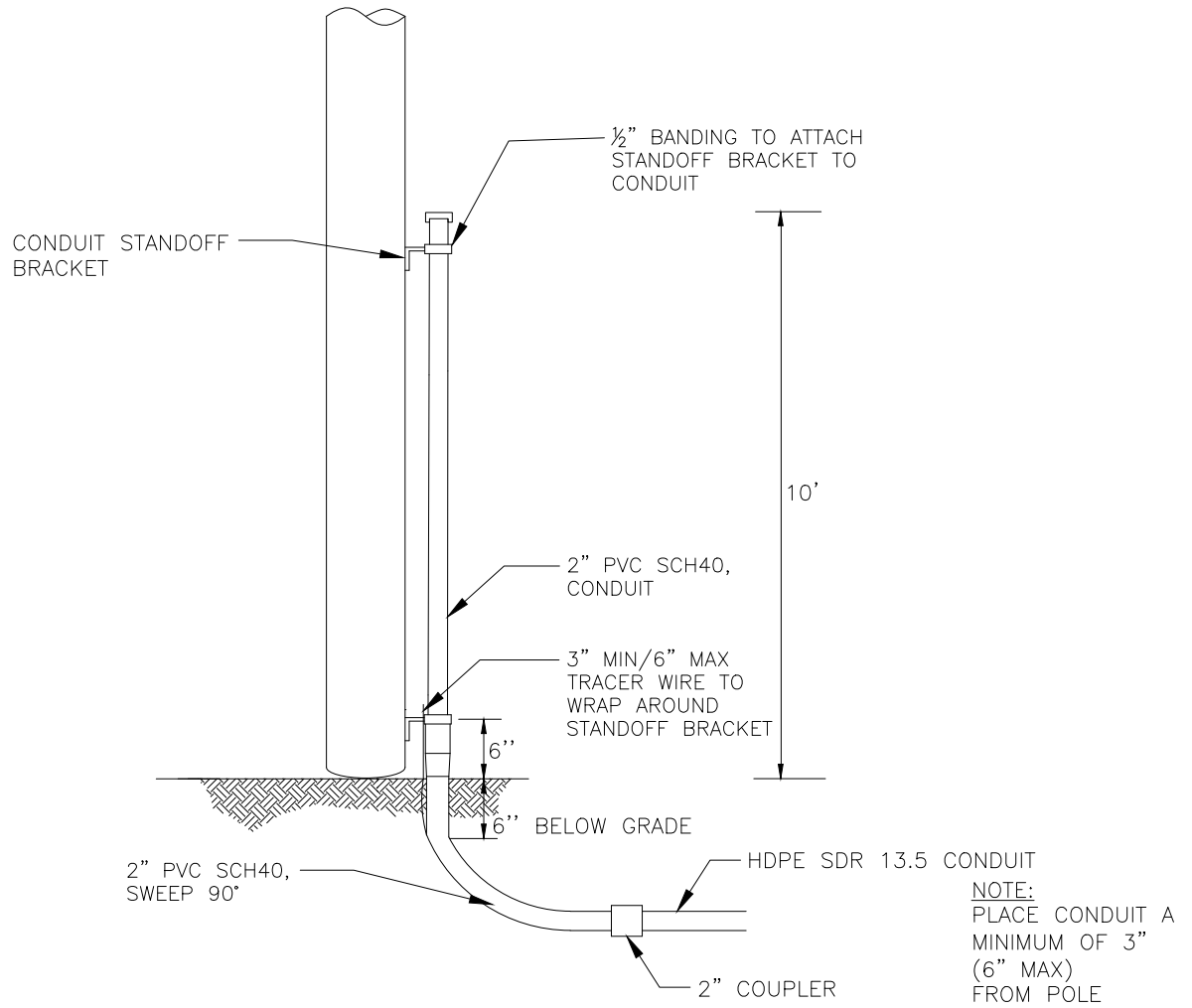

DESCRIPTION	QTY	MANUFACTURER (PREFERRED)	PART #
SCREW, LAG, 1/2" x 4-1/2"	10		
HDPE SDR 13.5 CONDUIT, VARIOUS SIZES	N/A		
2" PVC SCH40, RISER PIPE	1		
#12 TRACER WIRE	N/A		
2" PVC SCH40, SWEEP, 90 DEG	1		
CONDUIT STANDOFF BRACKET	VARIES		
CONDUIT STRAP KIT	VARIES		
2" COUPLER	1		



TYPICAL RISER
CONDUIT
WOOD POLE

(R2-W)

CONCEPTUAL SIDE VIEW

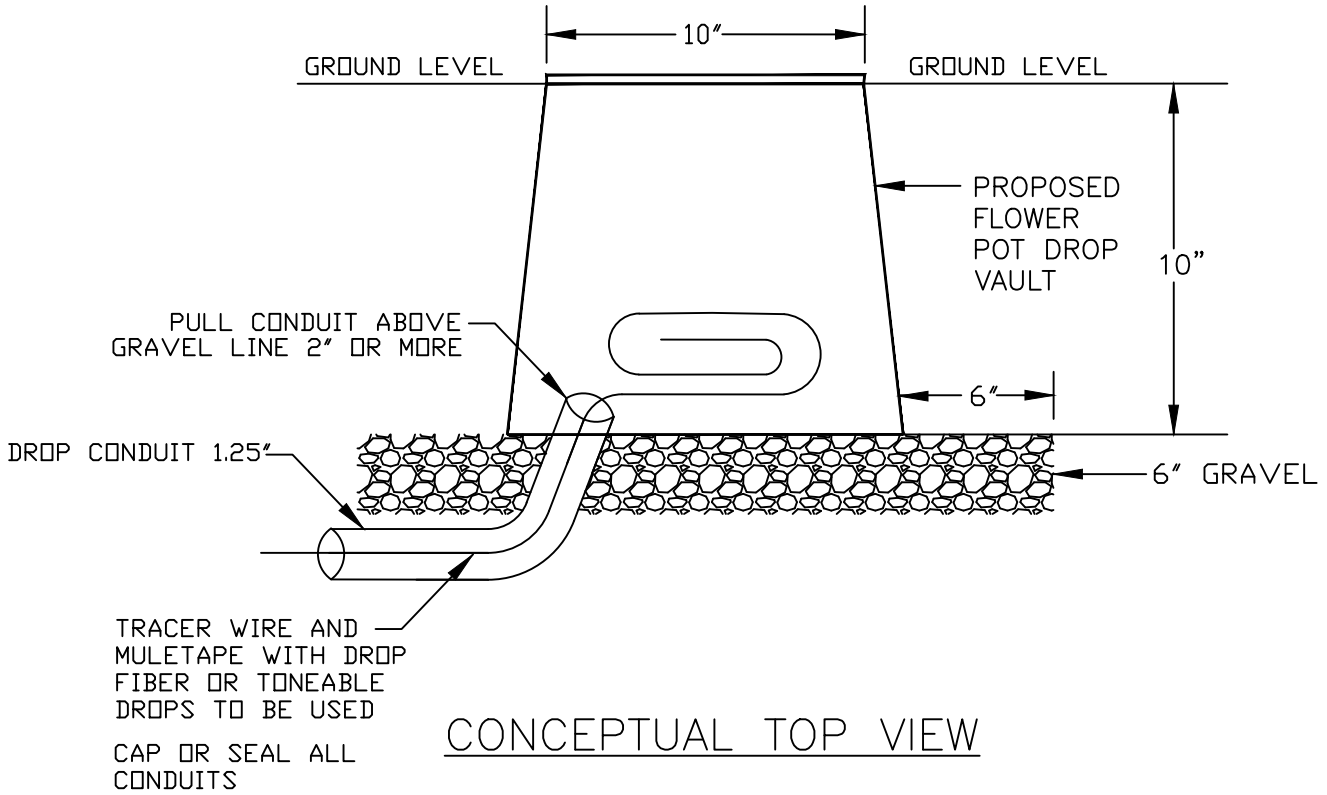

CONCEPTUAL TOP VIEW

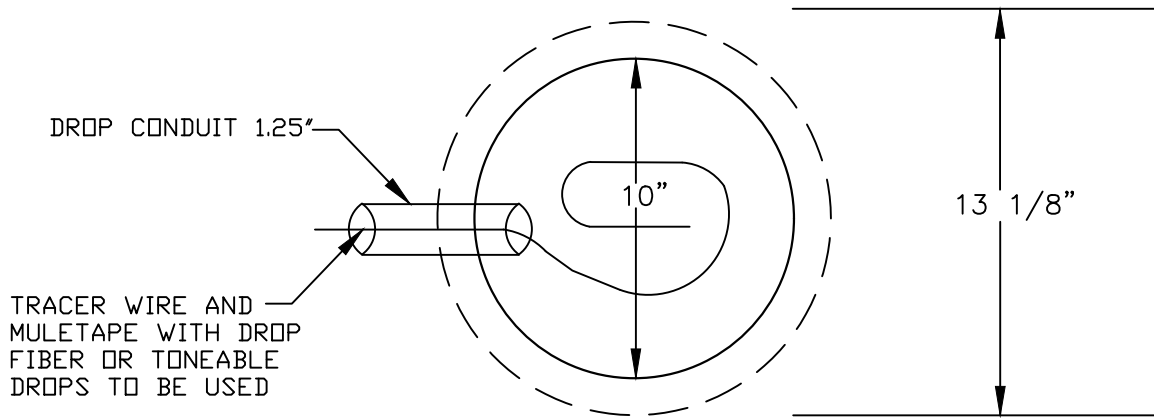

FLOWER POT

30"x48" PC UNIT, 2PC TIER 15/22
 18", 24", and 36" HEIGHT



AMERICAN POLYMER COMPANY

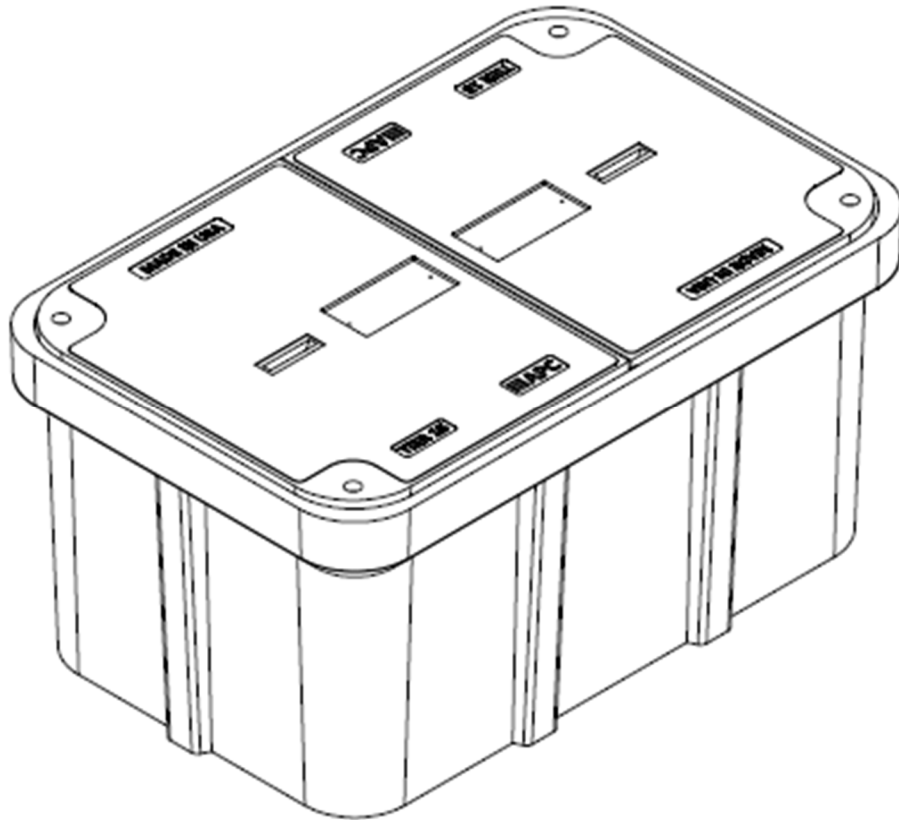

Description	Nominal Size	ANSI Tier	Part Number	Estimated Weight
PC Unit – TIER 15	30"x48"x18"	Tier 15	P304818HU15...	460 lbs.
PC Unit – TIER 22	30"x48"x18"	Tier 22	P304818HU22...	525 lbs.
PC Unit – TIER 15	30"x48"x24"	Tier 15	P304824HU15...	510 lbs.
PC Unit – TIER 22	30"x48"x24"	Tier 22	P304824HU22...	575 lbs.
PC Unit – TIER 15	30"x48"x36"	Tier 15	P304836HU15...	615 lbs.
PC Unit – TIER 22	30"x48"x36"	Tier 22	P304836HU22...	680 lbs.



30"x48" PC UNIT, 2PC TIER 15/22

18", 24", and 36" HEIGHT



AMERICAN POLYMER COMPANY

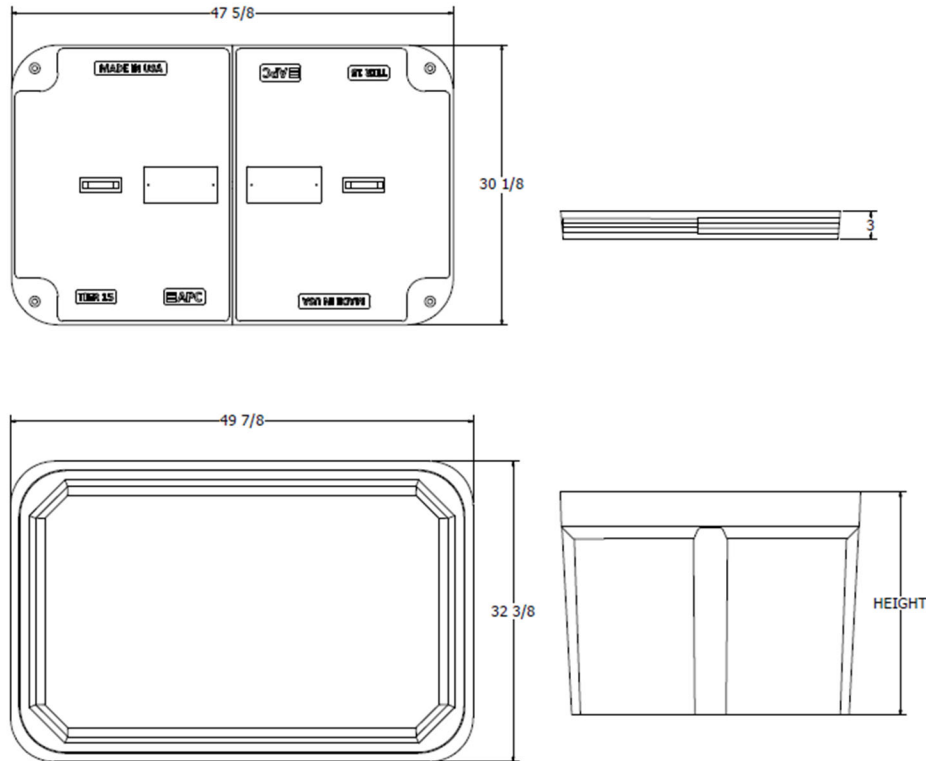

Components	Nominal Size	ANSI Tier	Part Number	Estimated Weight
Replacement Box	30"x48"x18"	Tier 22	P304818B22	185 lbs.
Replacement Box	30"x48"x24"	Tier 22	P304824B22	235 lbs.
Replacement Box	30"x48"x36"	Tier 22	P304836B22	340 lbs.
Replacement Lids - T15	30"x48" (half)	Tier 15	Various	150 lbs.
Replacement Lids - T22	30"x48" (half)	Tier 22	Various	170 lbs.

Bolt options



Machine Thread



Auger Thread



24"x36" PC UNIT, TIER 15/22
 18", 24", 30", and 36" HEIGHT



AMERICAN POLYMER COMPANY

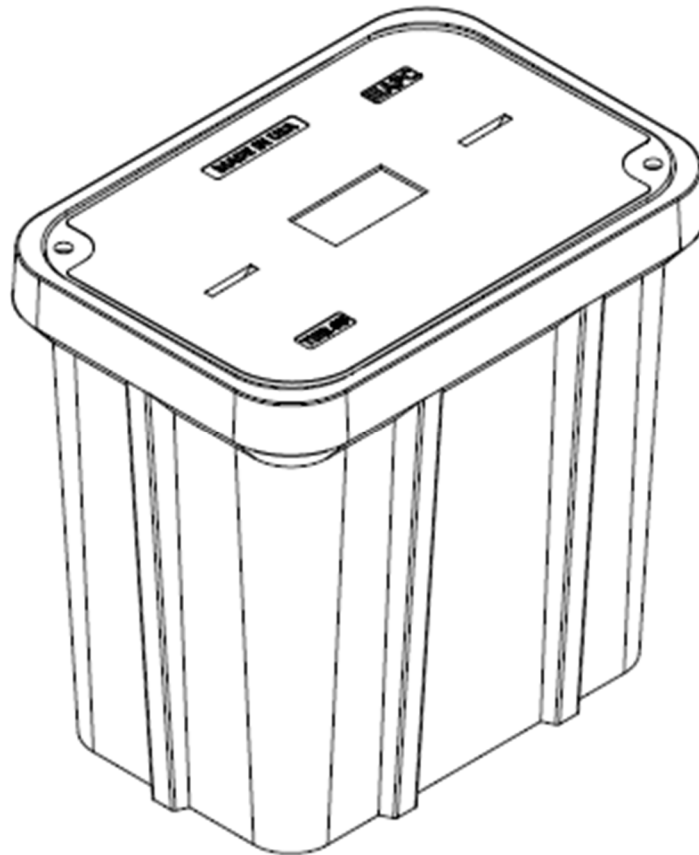

Description	Nominal Size	ANSI Tier	Part Number	Estimated Weight
PC Unit – TIER 15	24x36"x18"	Tier 15	P243618U15...	335 lbs.
PC Unit – TIER 22	24x36"x18"	Tier 22	P243618U22...	355 lbs.
PC Unit – TIER 15	24x36"x24"	Tier 15	P243624U15...	365 lbs.
PC Unit – TIER 22	24x36"x24"	Tier 22	P243624U22...	385 lbs.
PC Unit – TIER 15	24x36"x30"	Tier 15	P243630U15...	395 lbs.
PC Unit – TIER 22	24x36"x30"	Tier 22	P243630U22...	415 lbs.
PC Unit – TIER 15	24x36"x36"	Tier 15	P243636U15...	425 lbs.
PC Unit – TIER 22	24x36"x36"	Tier 22	P243636U22...	445 lbs.



24"x36" PC UNIT, TIER 15/22

18", 24", 30", and 36" HEIGHT



AMERICAN POLYMER COMPANY

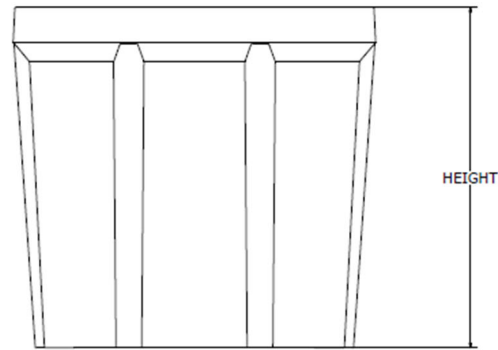
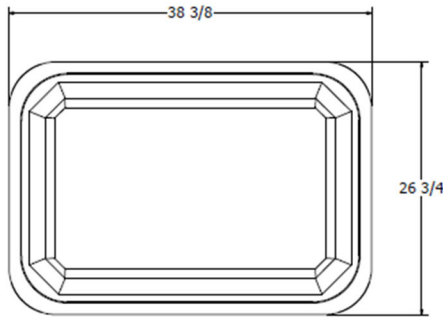
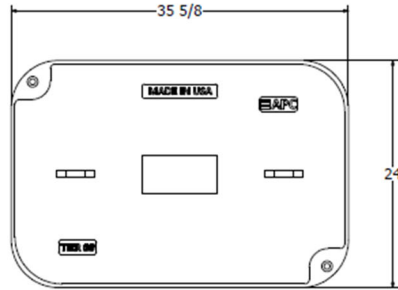

Components	Nominal Size	ANSI Tier	Part Number	Estimated Weight
Replacement Box	24"x36"x18"	Tier 22	P243618B22	165 lbs.
Replacement Box	24"x36"x24"	Tier 22	P243624B22	195 lbs.
Replacement Box	24"x36"x30"	Tier 22	P243630B22	225 lbs.
Replacement Box	24"x36"x36"	Tier 22	P243636B22	255 lbs.
Replacement Lids - T15	24"x36"	Tier 15	Various	170 lbs.
Replacement Lids - T22	24"x36"	Tier 22	Various	190 lbs.

Bolt options

Hex Head



Machine Thread



Penta Head



Auger Thread



17"x30" PC UNIT, TIER 15/22

12", 18", 24", and 30" HEIGHT



AMERICAN POLYMER COMPANY

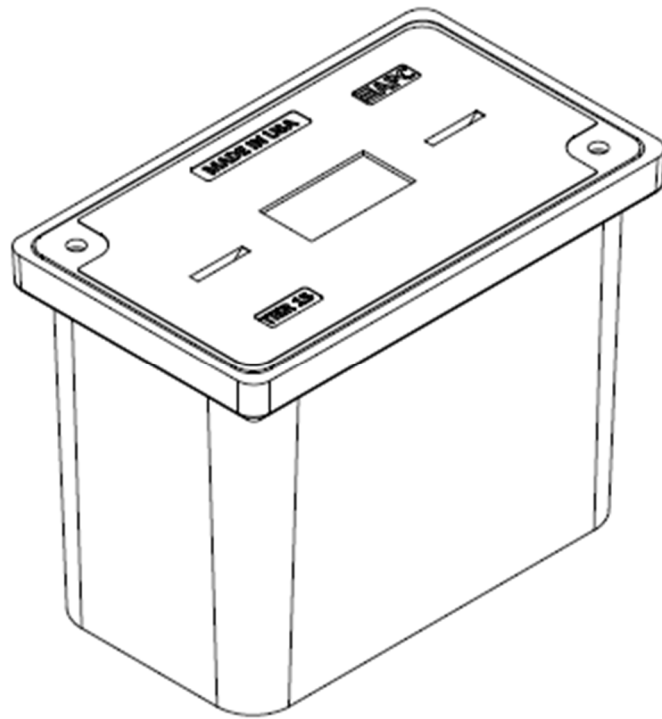

Description	Nominal Size	ANSI Tier	Part Number	Estimated Weight
PC Unit – TIER 15	17"x30"x12"	Tier 15	P173012U15...	138 lbs.
PC Unit – TIER 22	17"x30"x12"	Tier 22	P173012U22...	147 lbs.
PC Unit – TIER 15	17"x30"x18"	Tier 15	P173018U15...	172 lbs.
PC Unit – TIER 22	17"x30"x18"	Tier 22	P173018U22...	181 lbs.
PC Unit – TIER 15	17"x30"x24"	Tier 15	P173024U15...	192 lbs.
PC Unit – TIER 22	17"x30"x24"	Tier 22	P173024U22...	201 lbs.
PC Unit – TIER 15	17"x30"x30"	Tier 15	P173030U15...	217 lbs.
PC Unit – TIER 22	17"x30"x30"	Tier 22	P173030U22...	226 lbs.



17"x30" PC UNIT, TIER 15/22

12", 18", 24", and 30" HEIGHT



AMERICAN POLYMER COMPANY

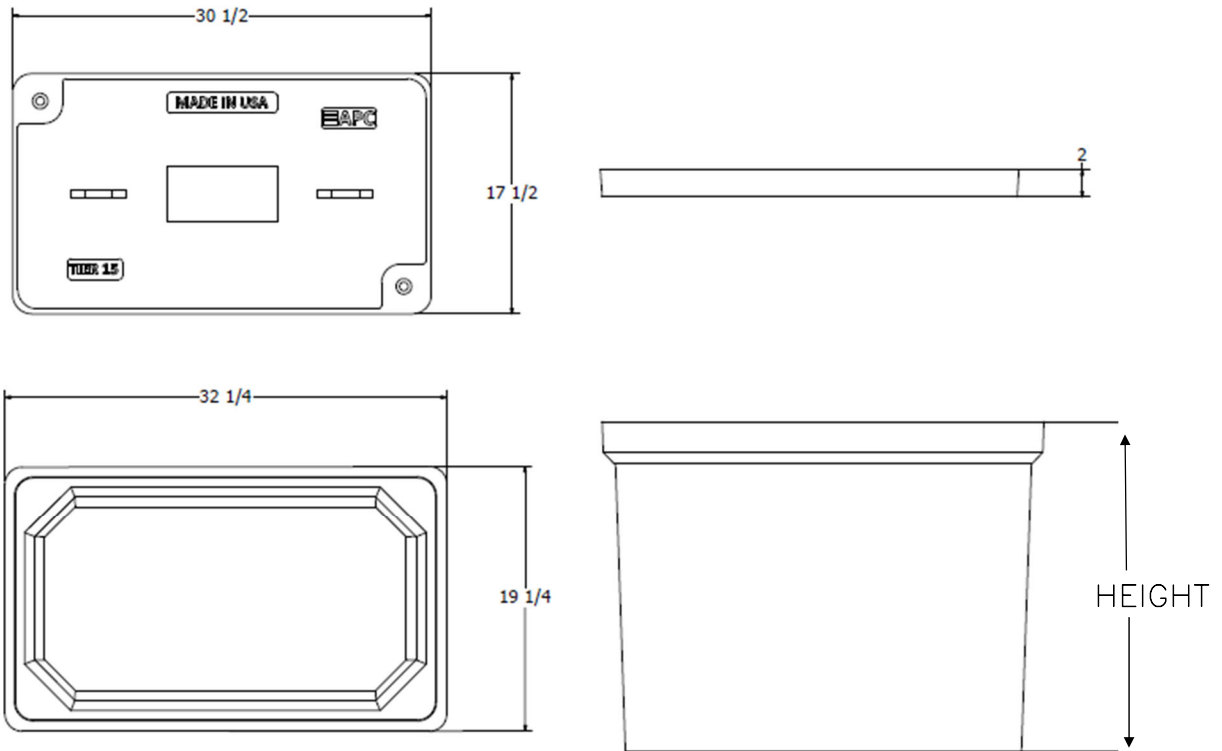

Components	Nominal Size	ANSI Tier	Part Number	Estimated Weight
Replacement Box	17"x30"x12"	Tier 22	P173012B22	66 lbs.
Replacement Box	17"x30"x18"	Tier 22	P173018B22	100 lbs.
Replacement Box	17"x30"x24"	Tier 22	P173024B22	120 lbs.
Replacement Box	17"x30"x30"	Tier 22	P173030B22	145 lbs.
Replacement Lids – T15	17"x30"	Tier 15	Various	72 lbs.
Replacement Lids – T22	17"x30"	Tier 22	Various	81 lbs.

Bolt options



Machine Thread



Auger Thread



33"x60" PC UNIT, 2PC TIER 15/22
36" HEIGHT



AMERICAN POLYMER COMPANY

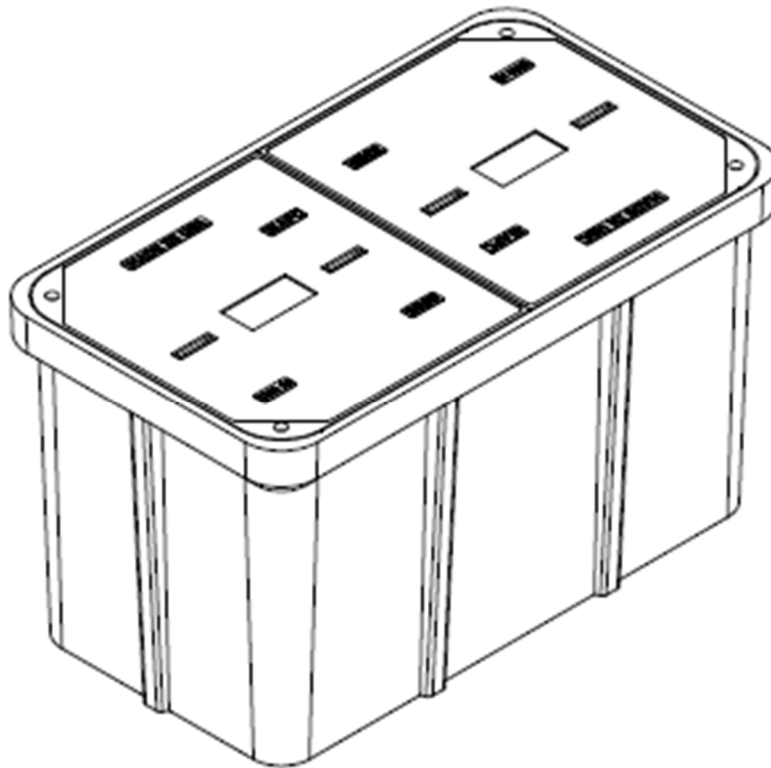

Description	Nominal Size	ANSI Tier	Part Number	Estimated Weight
PC Unit - TIER 15	33"x60"x36"	Tier 15	P336036U15...	930 lbs.
PC Unit - TIER 22	33"x60"x36"	Tier 22	P336036U22...	1030 lbs.



33"x60" PC UNIT, 2PC TIER 15/22

36" HEIGHT



AMERICAN POLYMER COMPANY

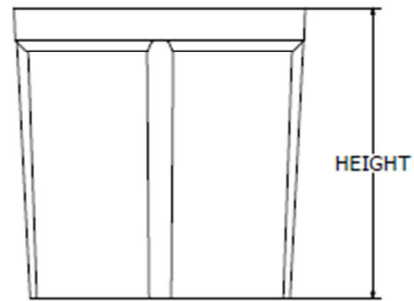
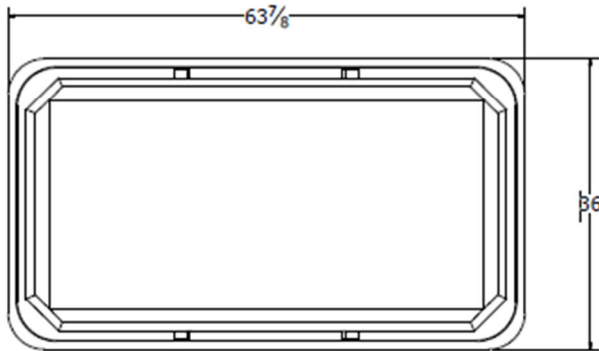
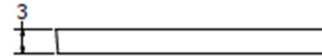

Components	Nominal Size	ANSI Tier	Part Number	Estimated Weight
Replacement Box	33"x60"x36"	Tier 22	P336036B22	530 lbs.
Replacement Lids - T15	33"x60" (half)	Tier 15	Various	200 lbs.
Replacement Lids - T22	33"x60" (half)	Tier 22	Various	250 lbs.

Bolt options

Hex Head



Machine Thread



Penta Head



Auger Thread



Speed (MPH) Prior To Road Work	SIGN SPACING, FT.		Must be Approved by an Engineer				
	Non-Divided Highways	Divided Highways	BUFFER SPACE, FT.	TAPER LENGTH, FT.	CHANNELIZING SPACING, FT.		
	Length	Shoulder (10 ft. Width)	Lane (12 ft. Width)	Through Taper	Through Buffer/Work Area		
0-35	200	200	250	70	245	35	50
40-45	350	500	360	150	540	40	80
50-55	500	1000	495	185	660	50	100
60-70	SA-1000, SB-1500, SC-2640		730	235	840	60	120
	Urban Low Speed - 100 FT						

APPROVED/ACCEPTED BY:
ENGINEER, OWNER, or PRIME CONTRACTOR
 Check for Notice to Proceed.

Signature: _____

Company: _____

Date: 12/7/2023 **Project:** BLN01b-F11 N Williams St TCP ;
Traffic Control Suggestion For: ATLANTIC ENGINEERING (AEG) ;
By: Road Runner Safety Services, Inc. : Nathan

Comments:
 Drawing not to scale. Traffic control plan must be approved by an engineer. This is a suggestion only. Road Runners Safety Services, Inc. has no liability for this suggested traffic control plan. Actual placement and spacing of all traffic control devices will depend on field conditions and must conform to MUTCD standards.

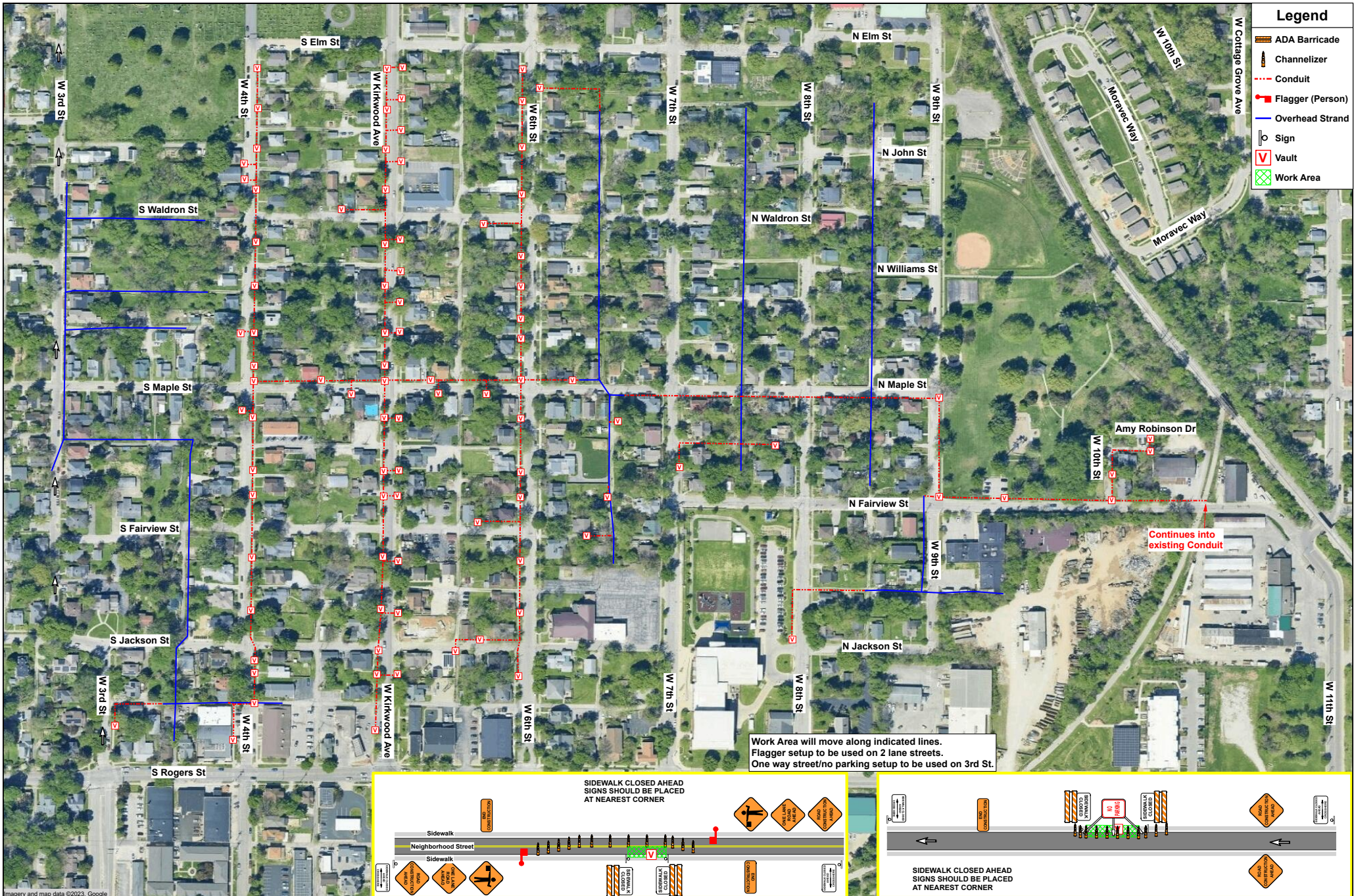



Board of Public Works Staff Report

Project/Event:	Lane and Sidewalk Closure Permit Request for AEG
Staff Representative:	Alex Gray
Petitioner/Representative:	Bret Simons
Date:	May 6 th , 2024

Report: AEG is requesting an issued permit with lane and sidewalk closures for the area of E Moody Dr to continue their fiber installation in the City. This request will include only underground fiber placement in the City's ROW or utility easements and is expected to take 2 months with work beginning after the Board meeting. Details of the permit area are below.

E Moody Dr

This permit area includes W Grimes Ln by S Walnut St south along Walnut St to E Miller Dr and east to S Huntington Dr and north to E Hillside Dr. The area in between these streets are also included.



P.O. Box 349 | Buford, Georgia 30515
Main Office: (706)654-2298
www.aeg.cc

To: City of Bloomington – Engineering Department
Subject: City of Bloomington Right of Way Application

Dear Board Members,

Atlantic Engineering Group is planning a large FTTH project across the entire City of Bloomington. This work will take place at different locations throughout the year. In order to facilitate these upcoming projects, AEG is respectfully requesting access to the ROW as planned out in the submitted permits.

Weekday hours will be from 8-4pm. Hours Saturday will be from 8-3pm. This will only be restoration, splicing and/or cable pulling. School zone hours will be from 8:30-2:30pm.

Traffic control plans will be attached to each permit. No long-term road closures or sidewalk closures are expected. Signs and flaggers will be present when needed and move with the project as it moves throughout the city. The areas will all be identified on the plans we submit to the city's Engineering Department.

Proper door hangers will be placed prior to the construction starting in a particular area. The door hangers will provide information about the construction and contact information if any issues arise.

Bret Simons
Engineering Project Coordinator
Atlantic Engineering Group

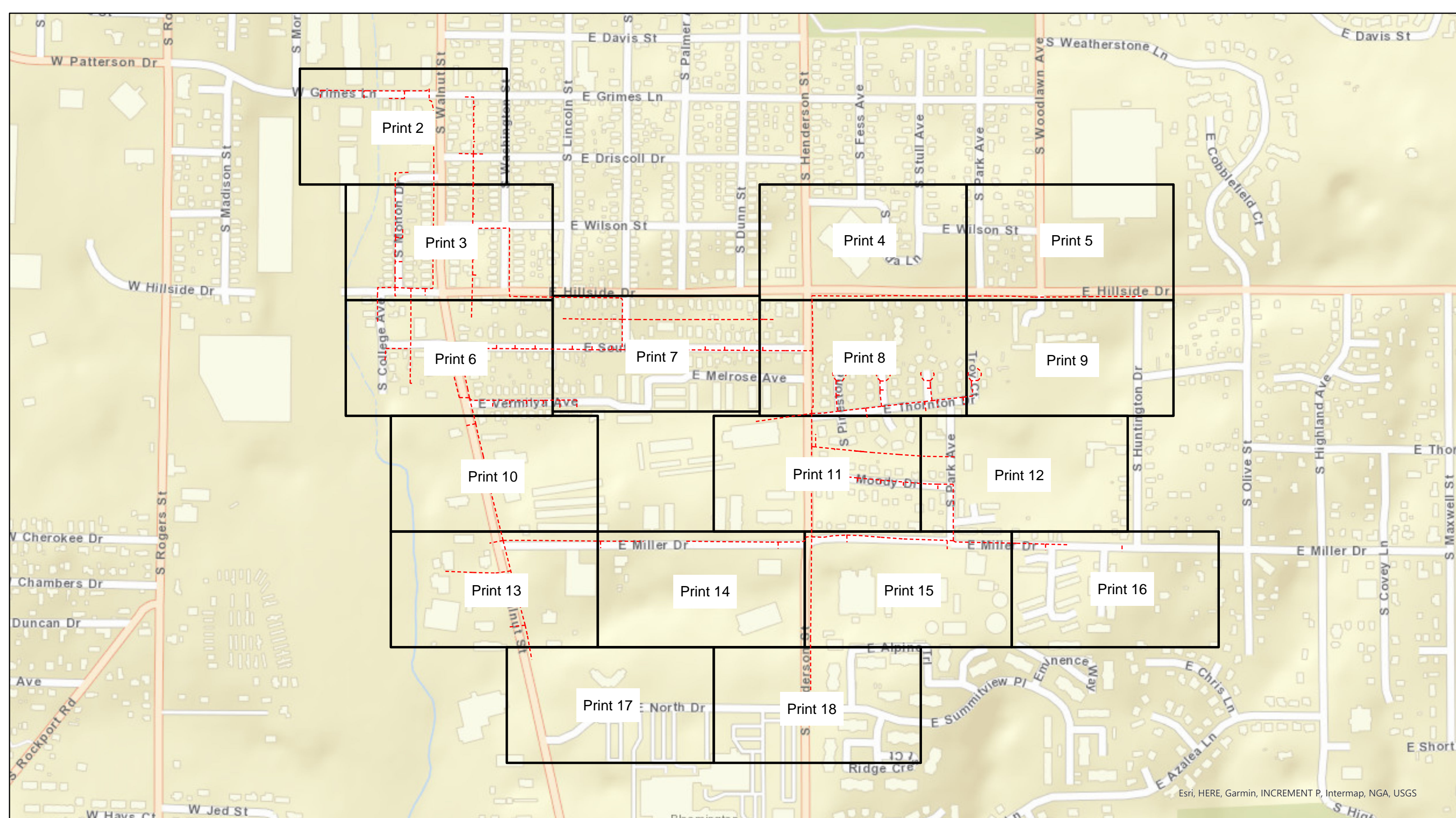

Esri, HERE, Garmin, INCREMENT P, Intermap, NGA, USGS



Legend BLC02a-F07_E Moody Dr

- Proposed Aerial
- - - Conduit
- Grids



City of Bloomington, IN Permit:
Design View

INI	BY	DATE	DESCRIPTION

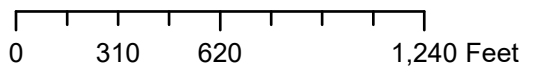

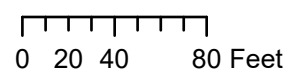
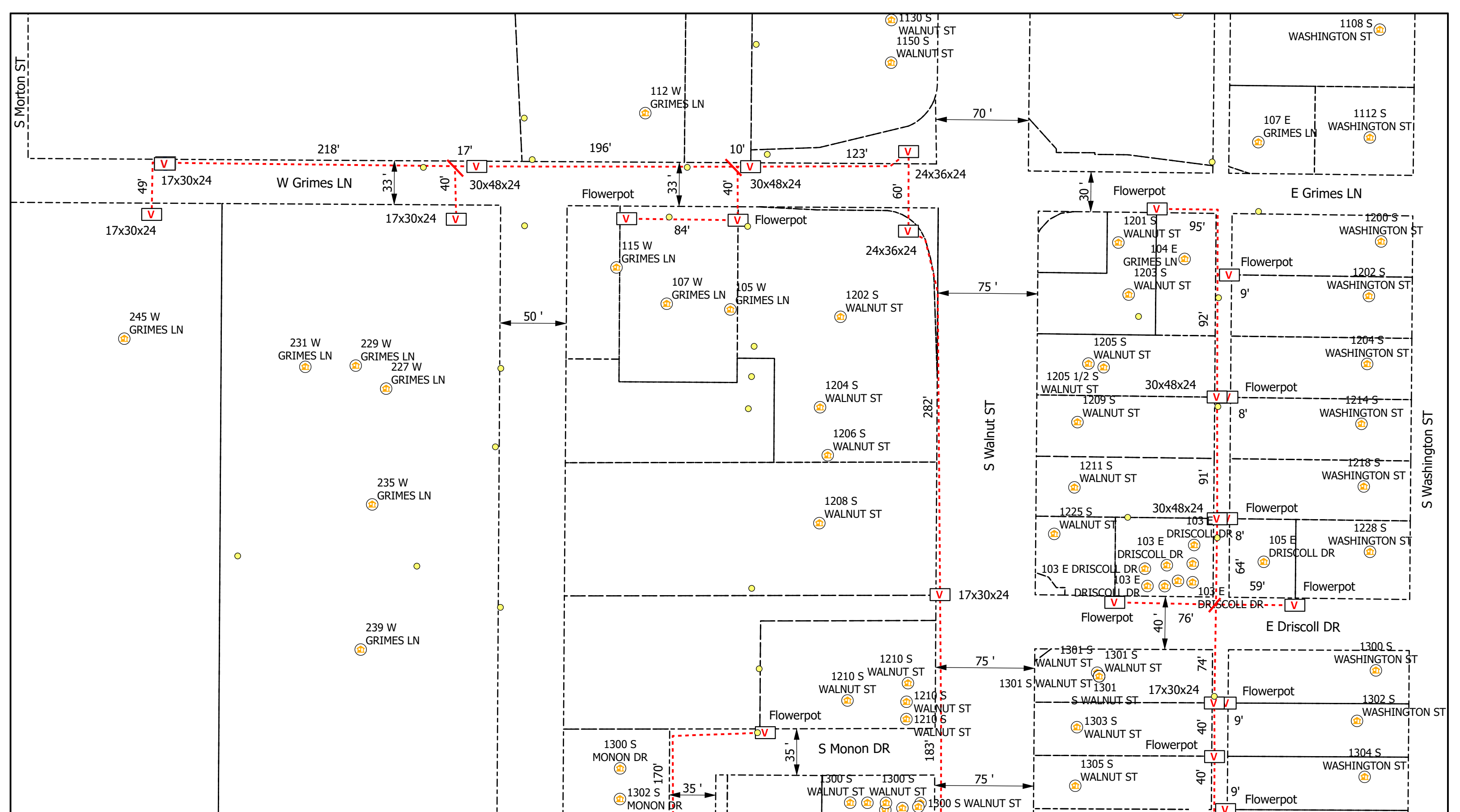

Legend

- Poles
- Ⓡ Risers
- Ⓜ Sidewalk
- V Vaults
- Overhead Strand
- Conduit
- Ⓜ Address
- Y Anchor
- Bloomington_Parcels
- Grids

All Flowerpots 12" DIA



City of Bloomington, IN Permit:
Design View

INI	BY	DATE	DESCRIPTION



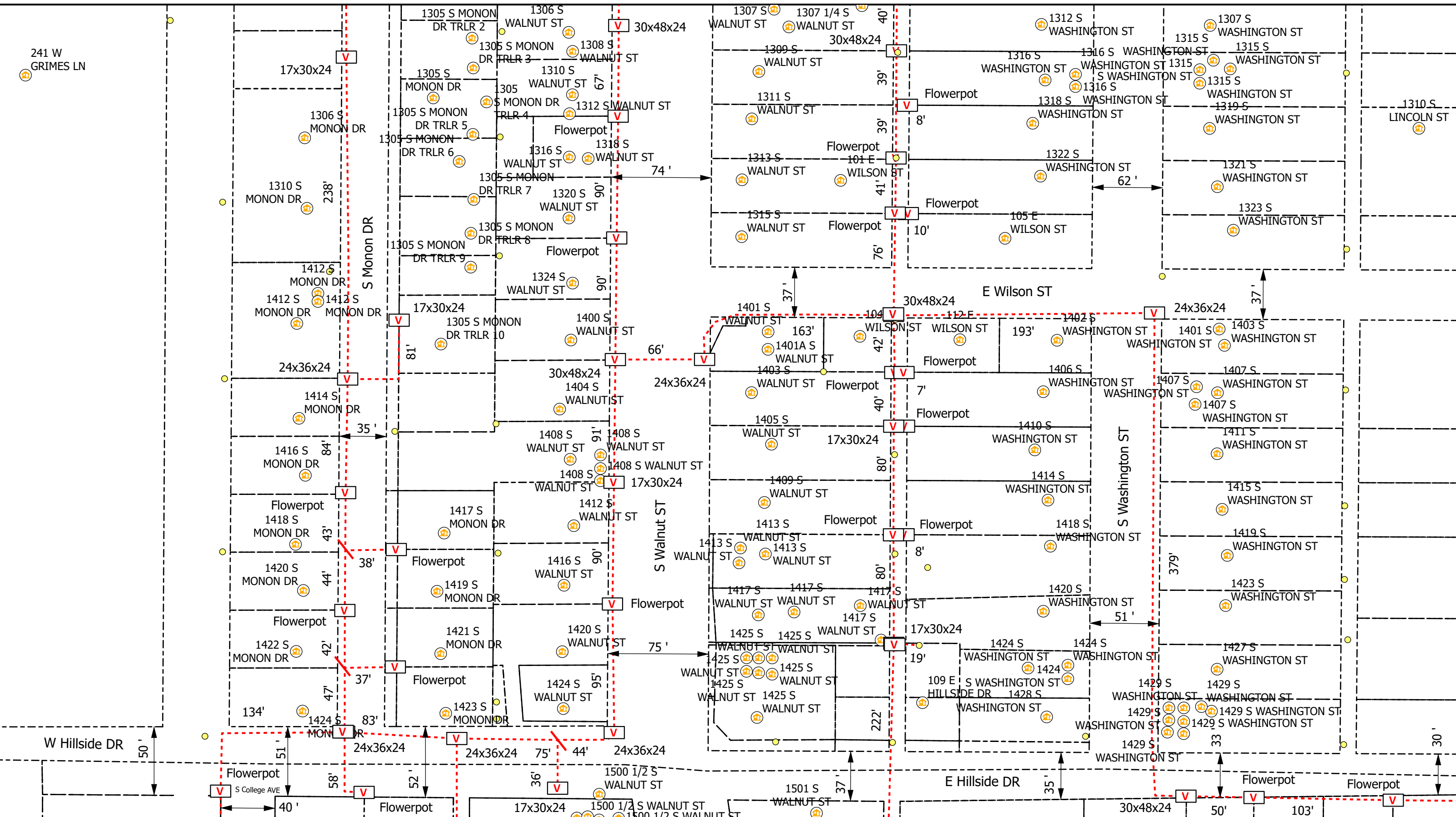

Legend

- Poles
- Risers
- Sidewalk
- Vaults
- Address
- Bloomington_Parcels
- Overhead Strand
- Anchor
- Conduit
- Grids

All Flowerpots 12" DIA

N

City of Bloomington, IN Permit:
Design View

INI	BY	DATE	DESCRIPTION

Print 3 of 18

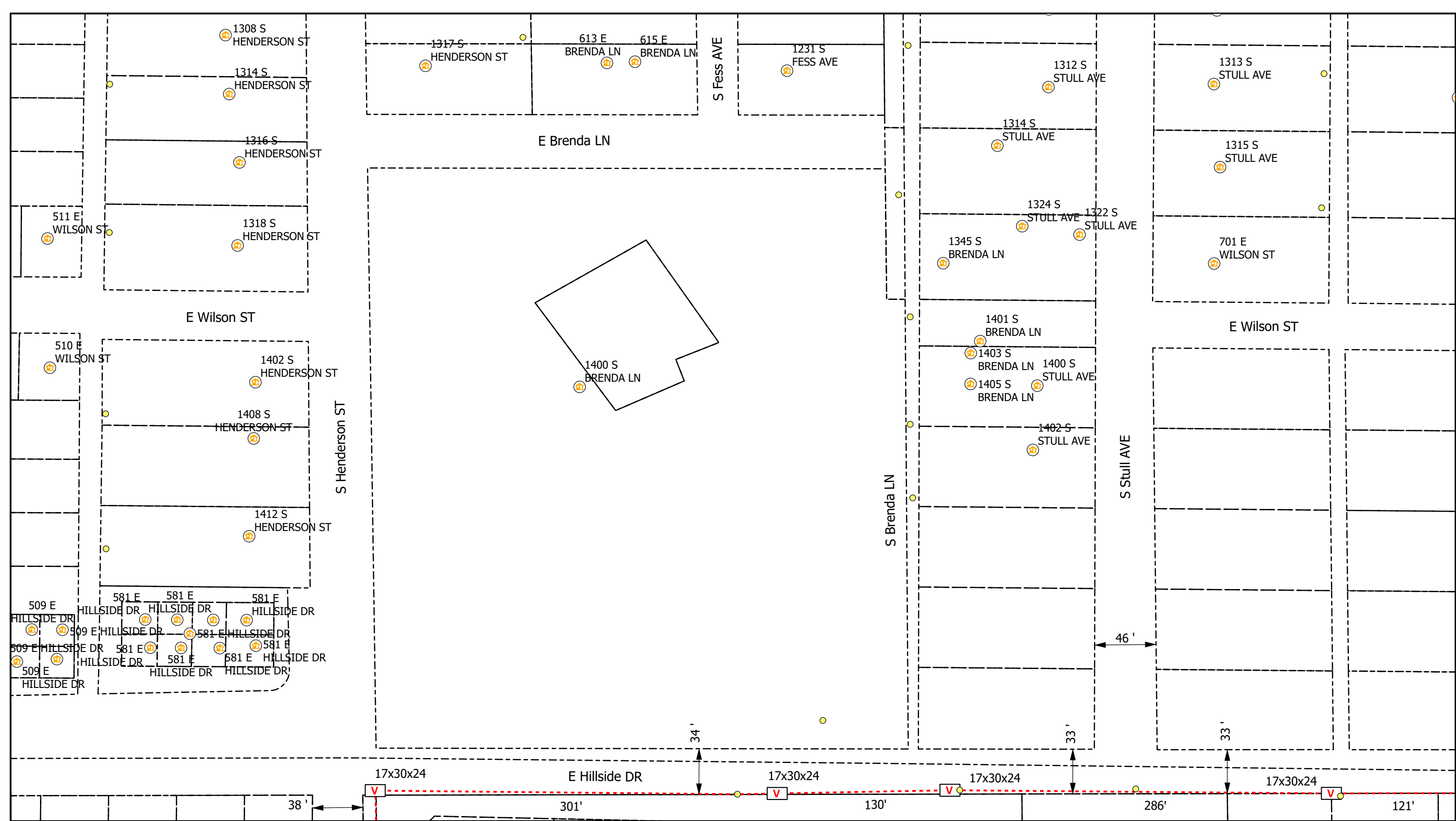

Legend

- Poles
- V Vaults
- Overhead Strand
- - - Conduit
- R Risers
- A Address
- Y Anchor
- ↖ Sidewalk
- Bloomington_Parcels
- Grids

All Flowerpots 12" DIA



City of Bloomington, IN Permit:
Design View

INI	BY	DATE	DESCRIPTION



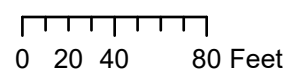
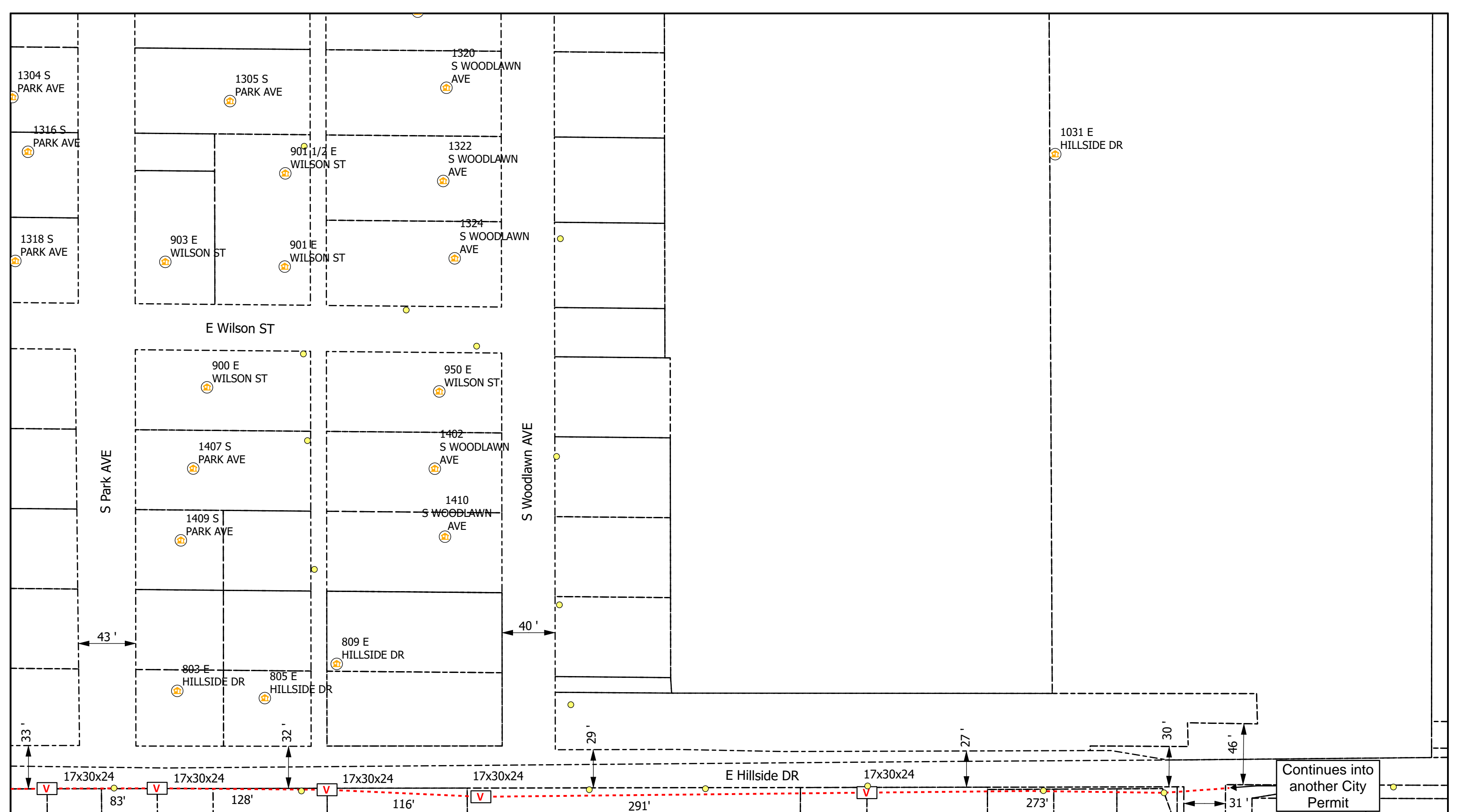

Legend

- Poles
- V Vaults
- Overhead Strand
- Conduit
- Ⓡ Risers
- Ⓜ Address
- Y Anchor
- ↖ Sidewalk
- Bloomington_Parcels
- Grids

All Flowerpots 12" DIA



City of Bloomington, IN Permit:
Design View

INI	BY	DATE	DESCRIPTION



Continues into another City Permit

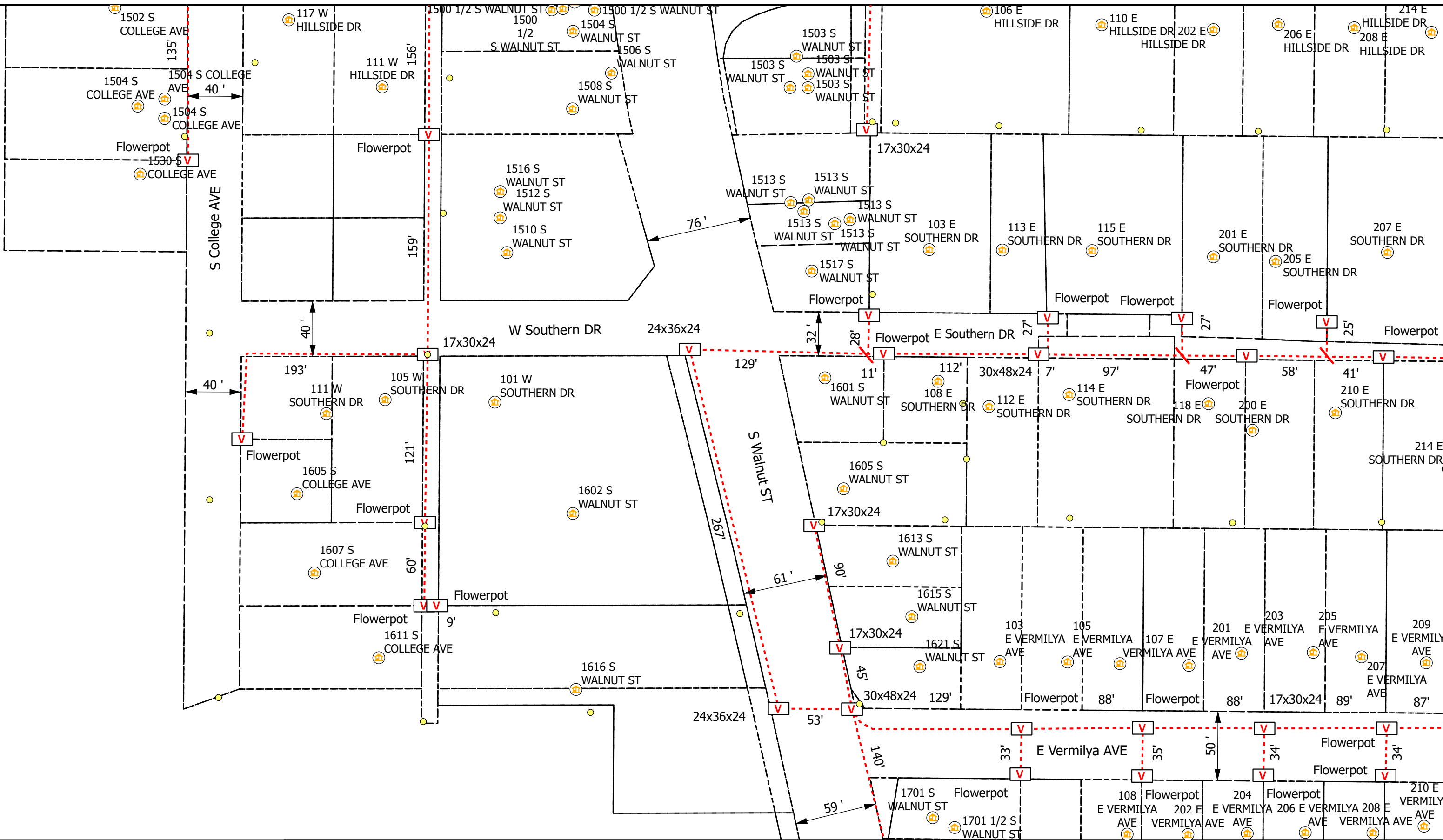

0 20 40 80 Feet

Legend

- Poles
- Vaults
- Overhead Strand
- Conduit
- Risers
- Address
- Anchor
- Sidewalk
- Bloomington_Parcels
- Grids

All Flowerpots 12" DIA

N

City of Bloomington, IN Permit:
Design View

INI	BY	DATE	DESCRIPTION

Print 6 of 18

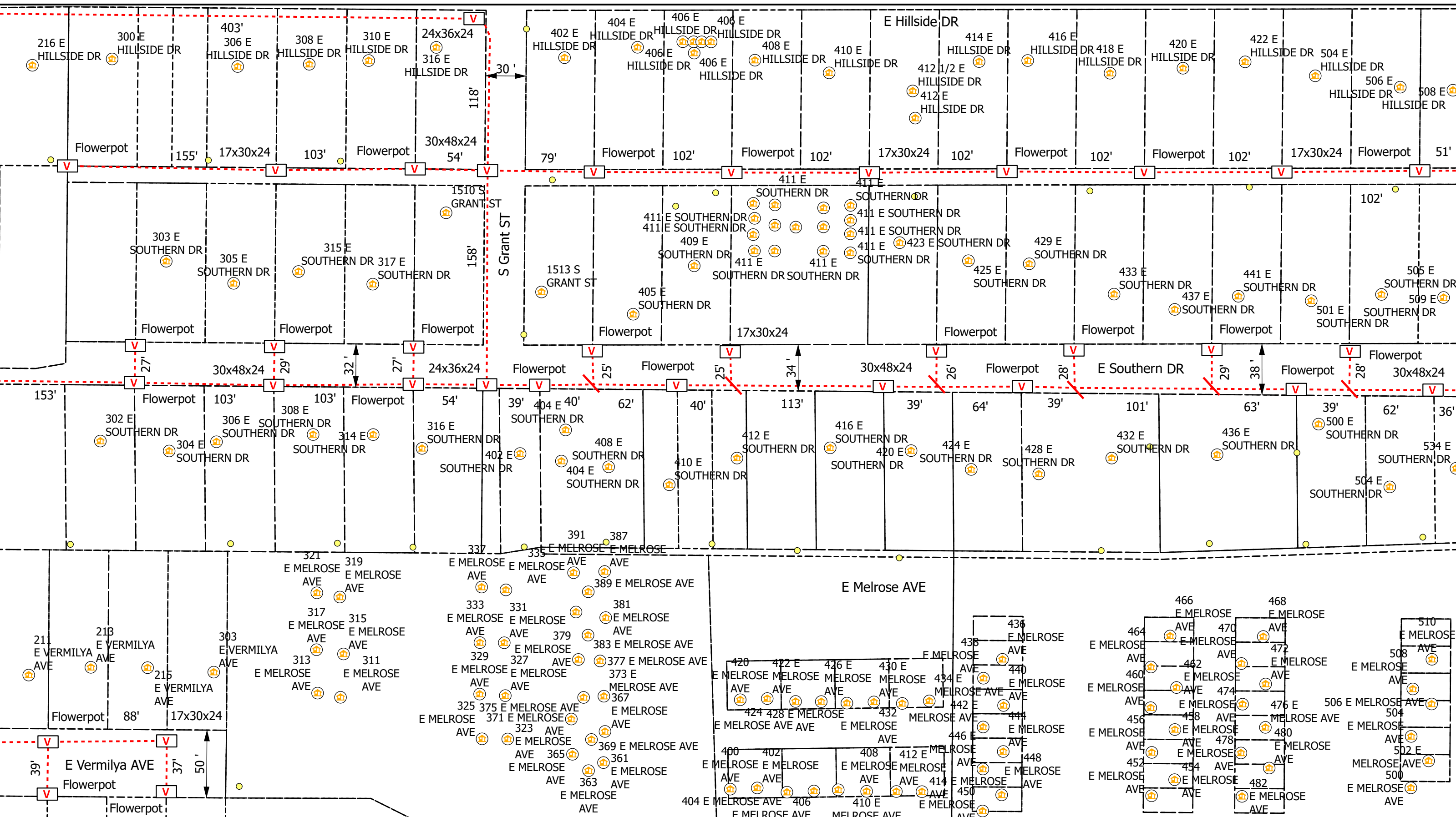

Legend

- Poles
- Risers
- Address
- Anchor
- Vaults
- Overhead Strand
- Conduit
- Sidewalk
- Bloomington_Parcels
- Grids

All Flowerpots 12" DIA

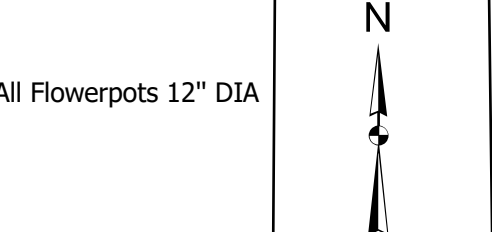

City of Bloomington, IN Permit:
Design View

INI	BY	DATE	DESCRIPTION

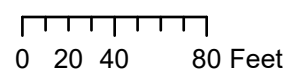
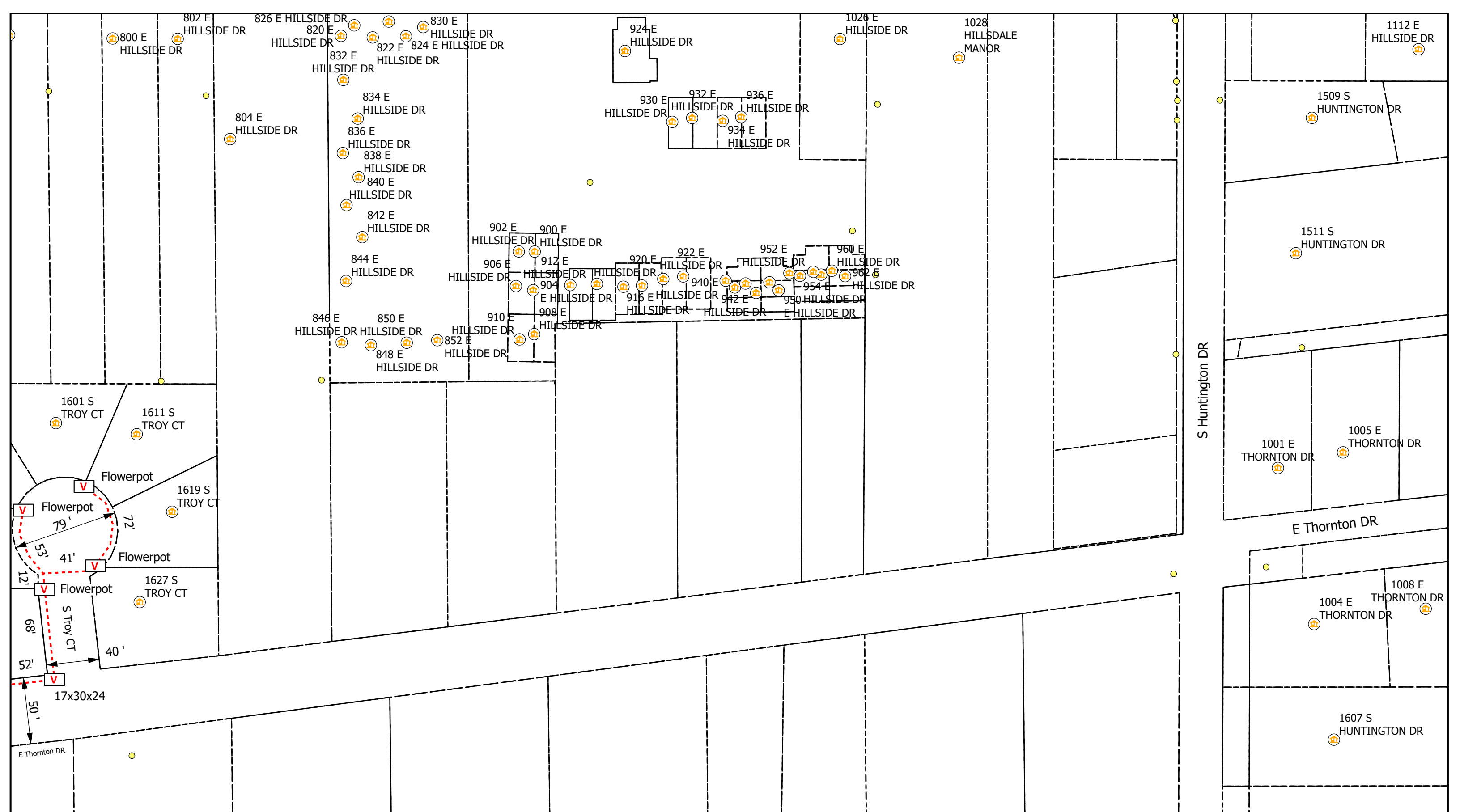

Legend

- Poles
- V Vaults
- Overhead Strand
- Conduit
- R Risers
- A Address
- Y Anchor
- └─ Sidewalk
- Bloomington_Parcels
- Grids

All Flowerpots 12" DIA



City of Bloomington, IN Permit:
Design View

INI	BY	DATE	DESCRIPTION



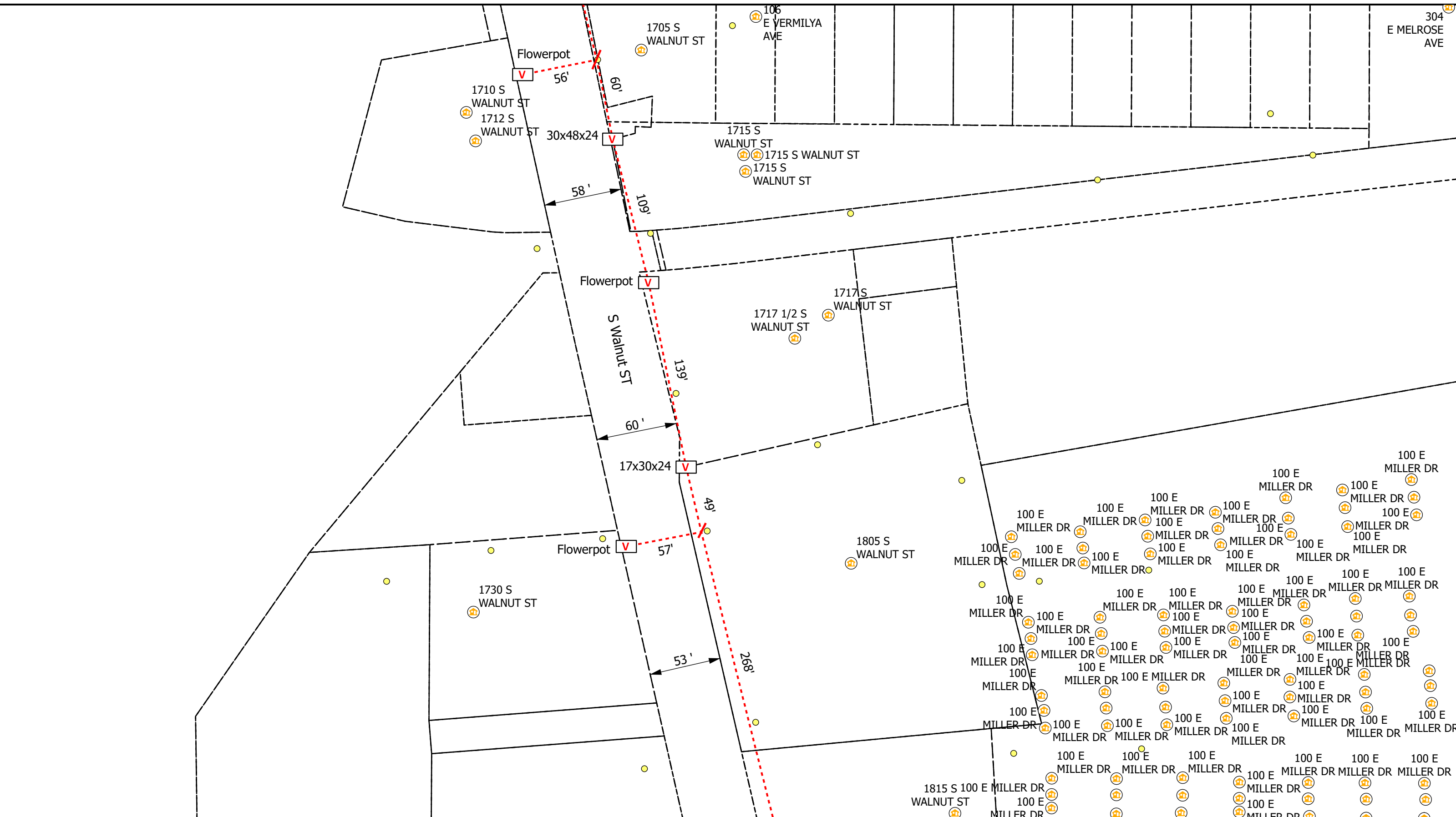

Legend

- Poles
- Address
- Risers
- Sidewalk
- Conduit
- Anchor
- Vaults
- Overhead Strand
- Bloomington_Parcels
- Grids

All Flowerpots 12" DIA

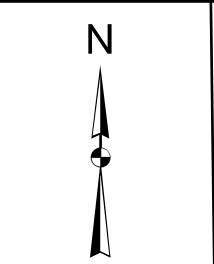

City of Bloomington, IN Permit:
Design View

INI	BY	DATE	DESCRIPTION

Print 10 of 18

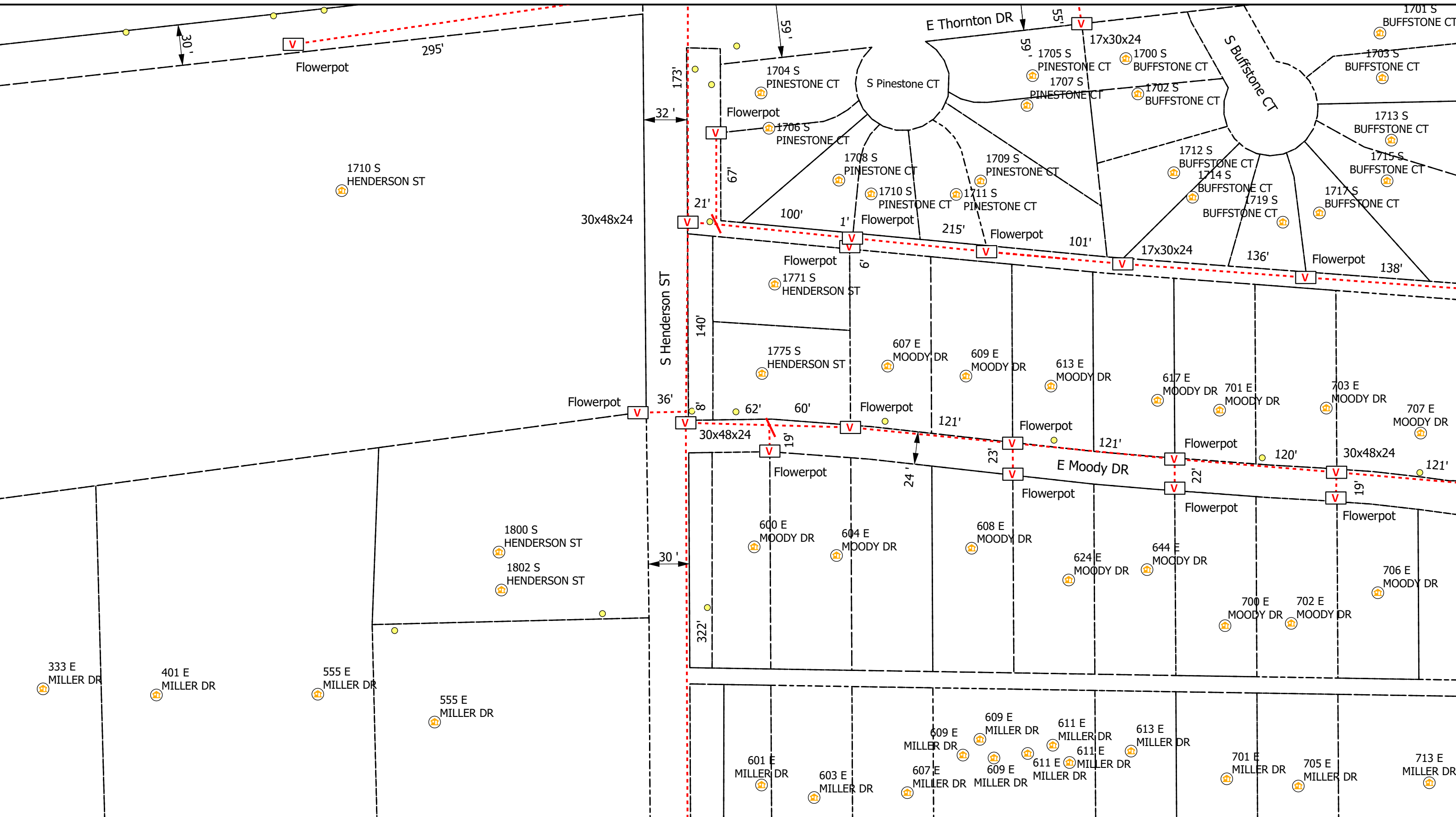

- Legend**
- Poles
 - Ⓡ Risers
 - Ⓜ Vaults
 - Overhead Strand
 - Conduit
 - Ⓜ Address
 - Y Anchor
 - ↖ Sidewalk
 - Bloomington_Parcels
 - Grids

All Flowerpots 12" DIA



City of Bloomington, IN Permit:
Design View

INI	BY	DATE	DESCRIPTION



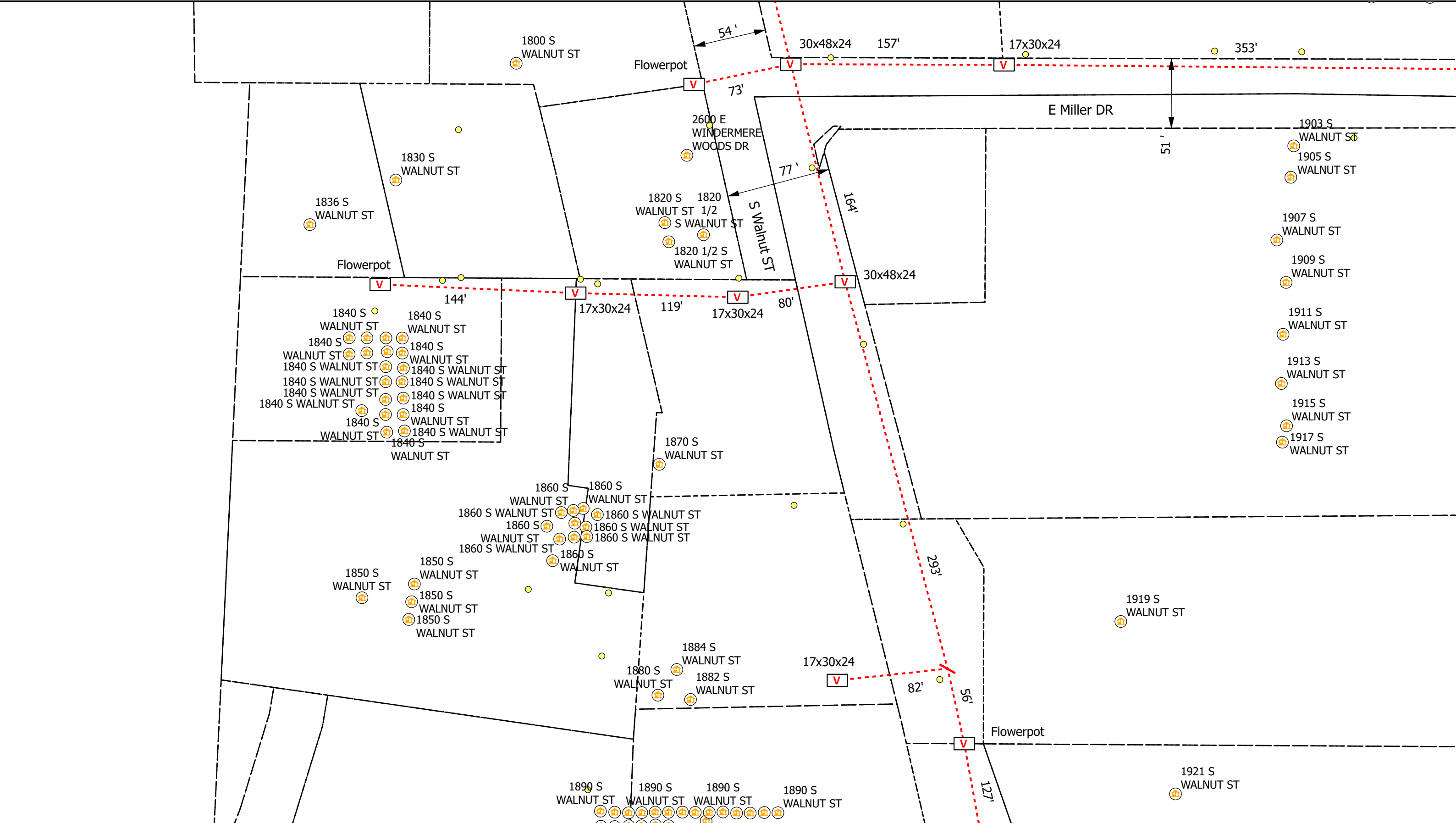

0 20 40 80 Feet

Legend

- Poles
- V Vaults
- Overhead Strand
- Conduit
- Ⓡ Risers
- Ⓜ Address
- Y Anchor
- ↖ Sidewalk
- Bloomington_Parcels
- Grids

All Flowerpots 12" DIA



City of Bloomington, IN Permit:
Design View

INI	BY	DATE	DESCRIPTION



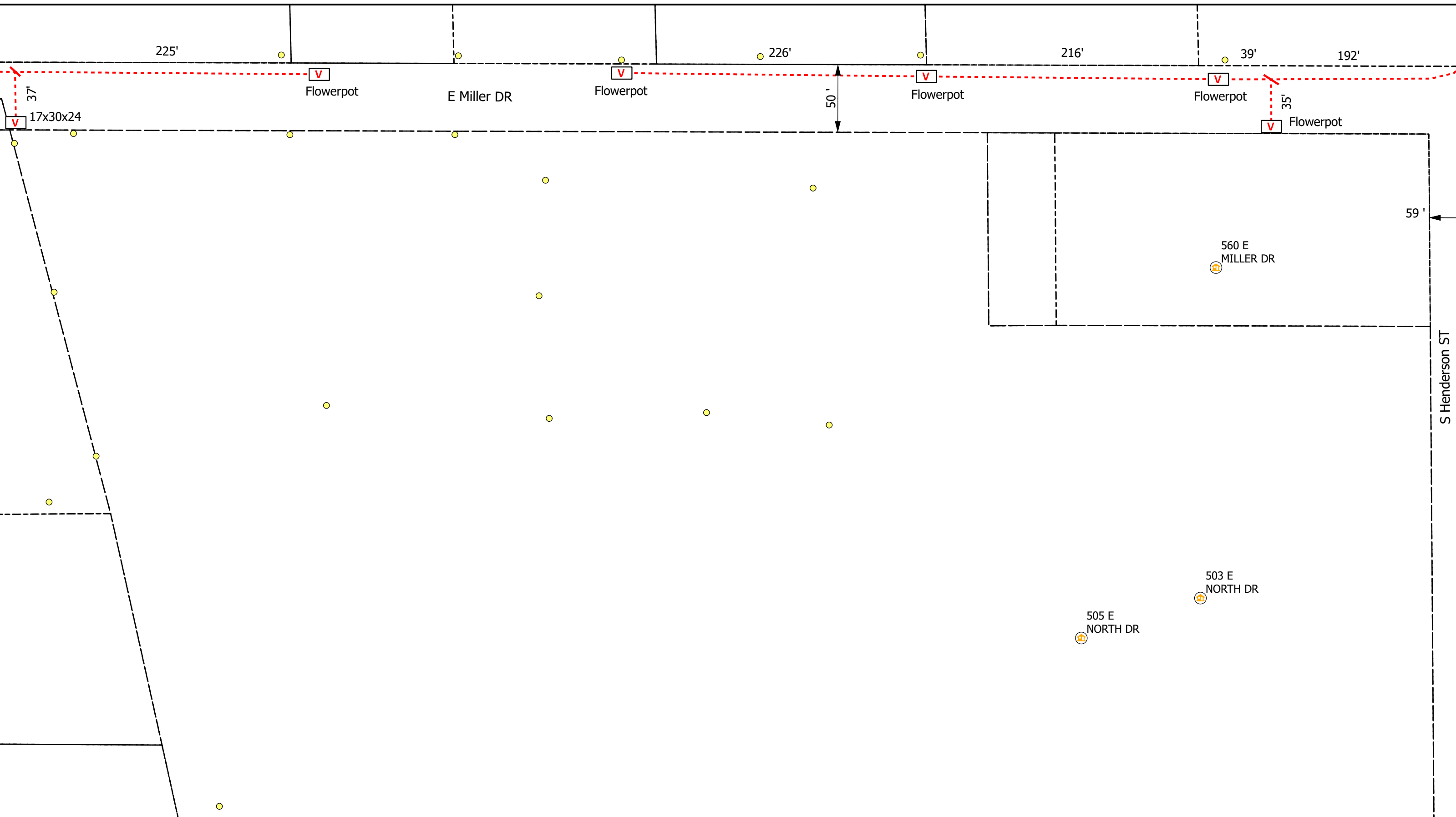

Legend

- Poles
- Vaults
- Overhead Strand
- Conduit
- Risers
- Address
- Anchor
- Sidewalk
- Bloomington_Parcels
- Grids

All Flowerpots 12" DIA

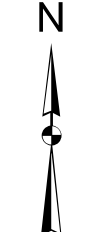

City of Bloomington, IN Permit:
Design View

INI	BY	DATE	DESCRIPTION

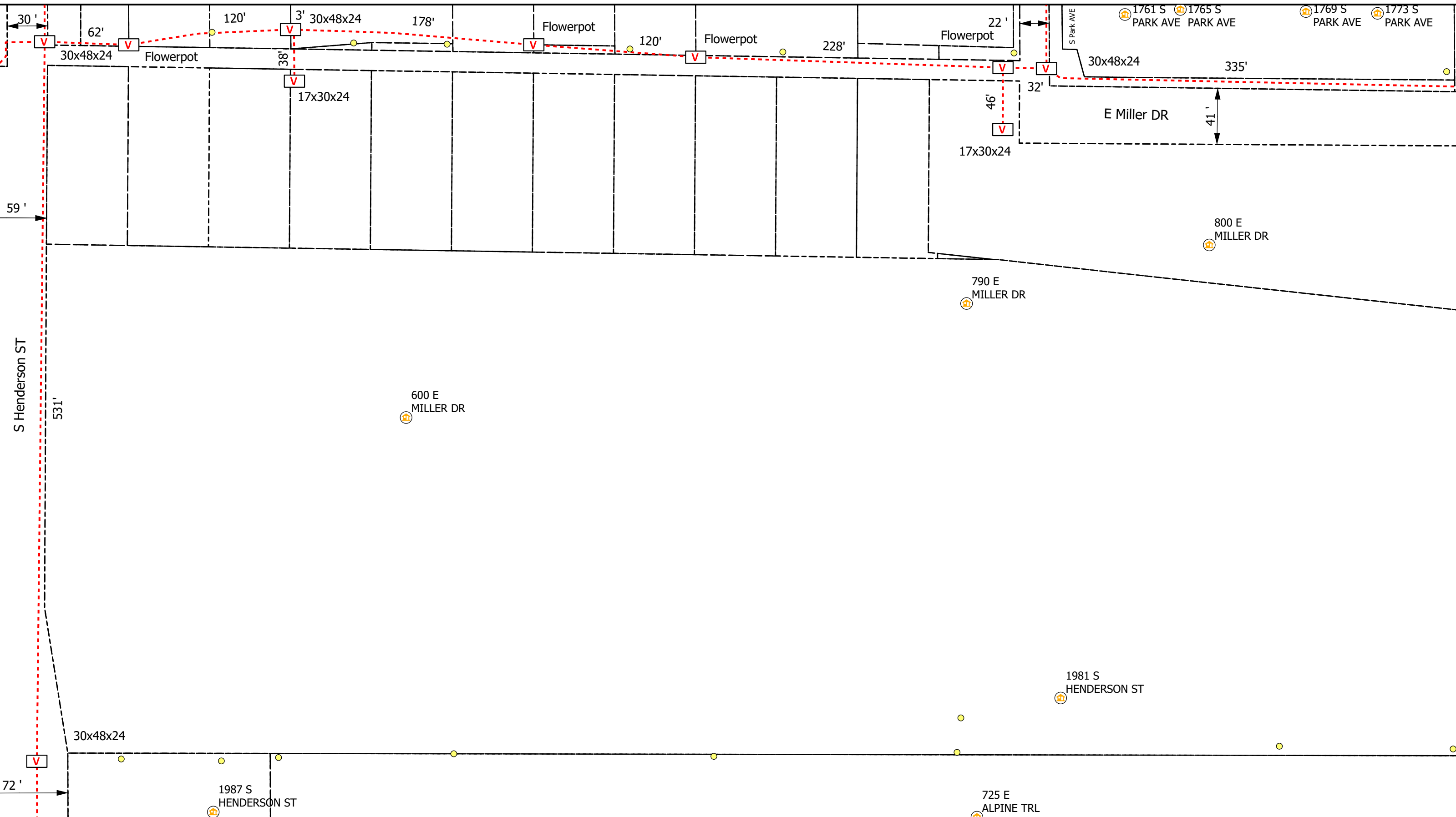

0 20 40 80 Feet

Legend

- Poles
- Risers
- Sidewalk
- Vaults
- Address
- Bloomington_Parcels
- Overhead Strand
- Anchor
- Conduit
- Grids

All Flowerpots 12" DIA

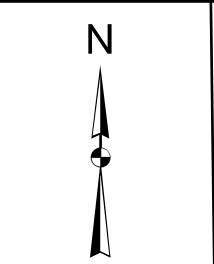

City of Bloomington, IN Permit:
Design View

INI	BY	DATE	DESCRIPTION

Print 15 of 18

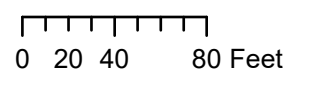
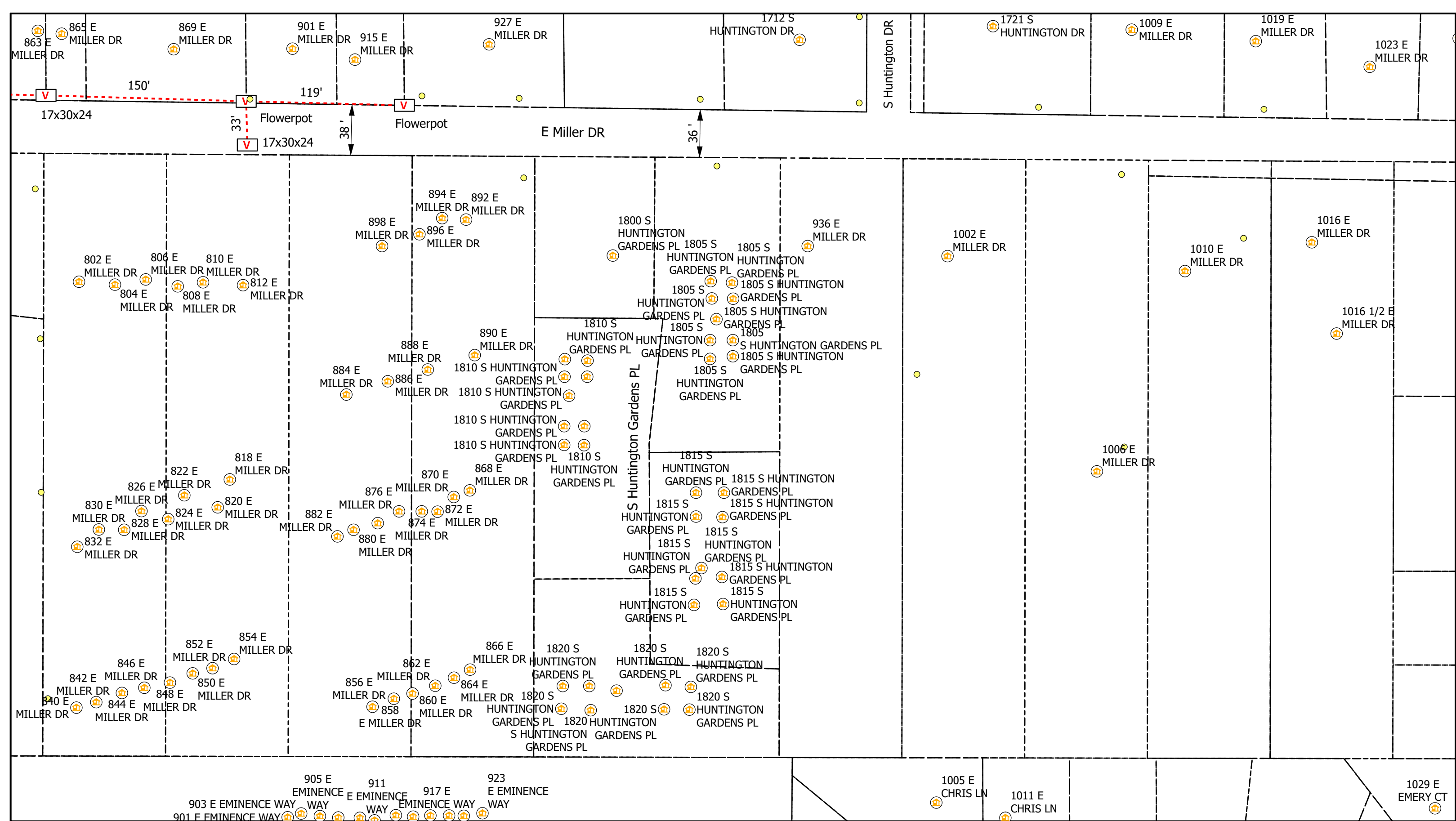

Legend

- Poles
- Ⓡ Risers
- Ⓥ Vaults
- Overhead Strand
- - - Conduit
- 🏠 Address
- ⌞ Sidewalk
- Y Anchor
- Bloomington_Parcels
- Grids

All Flowerpots 12" DIA



City of Bloomington, IN Permit:
Design View

INI	BY	DATE	DESCRIPTION



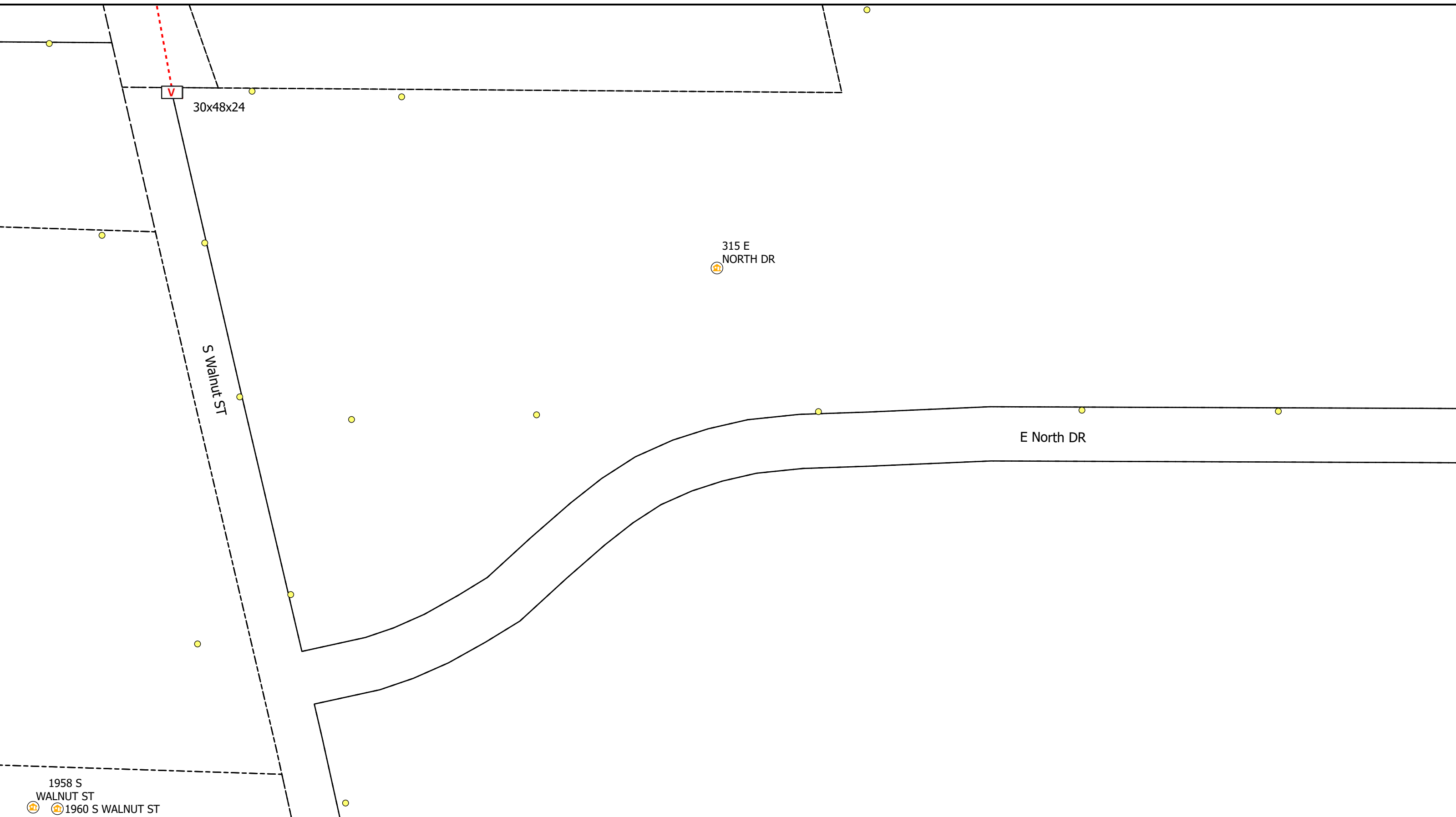

0 20 40 80 Feet

Legend

- Poles
- V Vaults
- Overhead Strand
- - - Conduit
- R Risers
- A Address
- Y Anchor
- ↖ Sidewalk
- Bloomington_Parcels
- Grids

All Flowerpots 12" DIA



City of Bloomington, IN Permit:
Design View

INI	BY	DATE	DESCRIPTION



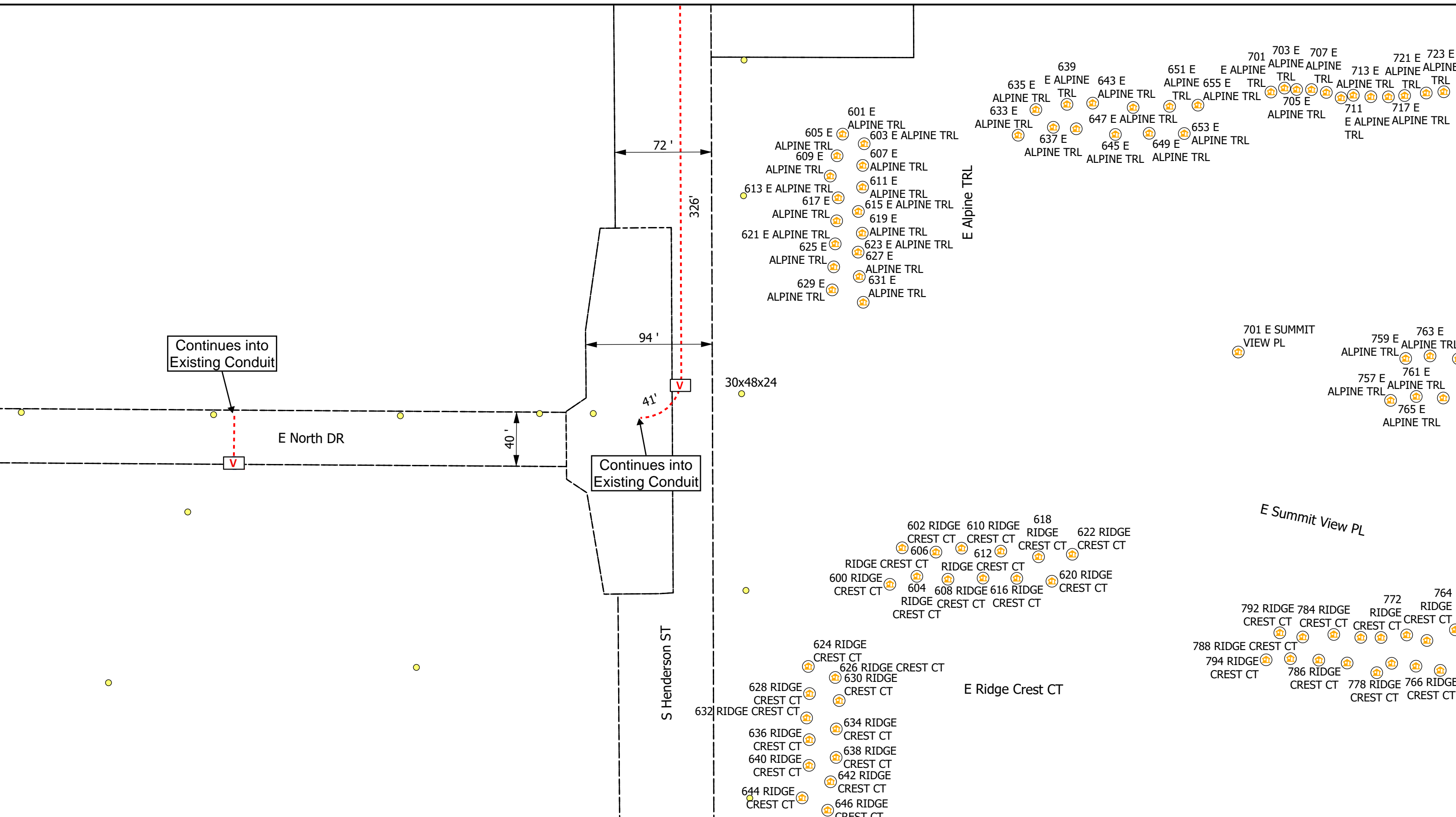

Legend

- Poles
- Risers
- Sidewalk
- Vaults
- Address
- Bloomington_Parcels
- Overhead Strand
- Anchor
- Conduit
- Grids

All Flowerpots 12" DIA

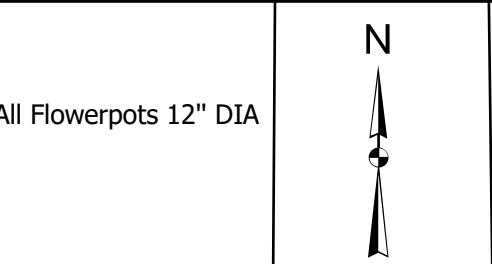

City of Bloomington, IN Permit:
Design View

INI	BY	DATE	DESCRIPTION

Carlton® PV-Mold® Nonmetallic Pole Riser System

Carlton PV-Mold is a nonmetallic pole riser system designed to protect communications power cable installed on poles.

Features:

- Meets or exceeds requirements outlined in the National Electric Safety Code (NESC).
- Designed in accordance with NEMA TC-19 specifications.
- Ultraviolet, cold temperature and corrosive atmosphere resistant.
- Schedule 40 wall meets Schedule 80 PVC conduit impact requirements per NEMA TC-19.
- No grounding required.
- Belled end fits over each added section or conduit.
- Flame retardant.
- Requires no maintenance.
- PV-Mold acts as an insulator against electrical shock.
- Interchangeable parts and accessories to match the needs of specific requirements.



Steel U-Guard requires grounding strapping and does not have belled ends.



PV-Mold has belled ends, flanged design and does not require grounding.

Flanged Overall Length 10 Feet, Including Bell

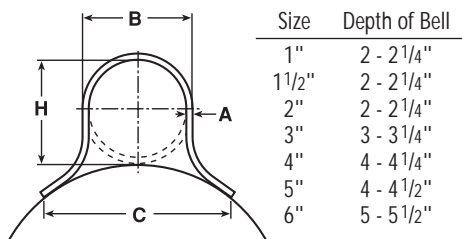

Slots are 1/2" from side to side, and allow for expansion and contraction.

Slot Dimensions: for sizes 2" through 6" are 5/16" wide, 3/4" long.

Slot Dimensions: for 1" and 1 1/2" are 3/16" wide, 3/4" long.

Slot Spacing: 18" from center, beginning 6" from end.

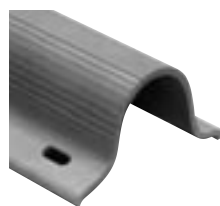

Standard Duty

Part No.	Size	Std. Ctn. Qty.	Std. Ctn. Wt. (lbs.)	Dimensions				Actual Impact @ 0°C 20 Pound Top
				A	B	C	H	
59208N	1"	294	1059	0.100"	1 5/8"	2 3/8"	1 5/8"	40 Ft.-Lbs.
59211N	2"	136	726	0.100"	2 3/8"	4 1/2"	2 3/8"	100 Ft.-Lbs.
59211X (5' length)	2"	136	363	0.100"	2 3/8"	4 1/2"	2 3/8"	100 Ft.-Lbs.
59213N	3"	66	761	0.150"	3 1/2"	6"	3 1/2"	110 Ft.-Lbs.
59213X (5' length)	3"	66	381	0.150"	3 1/2"	6"	3 1/2"	100 Ft.-Lbs.
59215N	4"	65	910	0.150"	4 1/2"	6 1/2"	4 1/2"	110 Ft.-Lbs.
59216N	5"	30	515	0.150"	5 1/2"	7 1/2"	5 1/2"	110 Ft.-Lbs.

Heavy Duty Schedule 40

59010N	1 1/2"	200	1142	0.145"	1 29/32"	3 1/2"	1 29/32"	100 Ft.-Lbs.
59011N	2"	136	1214	0.154"	2 3/8"	4 1/2"	2 3/8"	150 Ft.-Lbs.
59013N	3"	66	937	0.216"	3 1/2"	6"	3 9/32"	150 Ft.-Lbs.
59015N	4"	65	1621	0.237"	4 1/2"	6 1/2"	4 1/2"	260 Ft.-Lbs.
59015X (5' length)	4"	65	707	0.237"	4 1/2"	6 1/2"	4 1/2"	260 Ft.-Lbs.
59016N	5"	30	870	0.258"	5 1/2"	7 1/2"	5 1/2"	260 Ft.-Lbs.
59017N	6"	30	1160	0.280"	6 5/8"	8 3/4"	6 5/8"	260 Ft.-Lbs.

Extra Heavy Duty Schedule 80

59411N	2"	136	1549	0.218"	2 3/8"	4 1/2"	2 3/8"	300 Ft.-Lbs.
59413N	3"	66	1495	0.030"	3 1/2"	6"	3 1/2"	525 Ft.-Lbs.

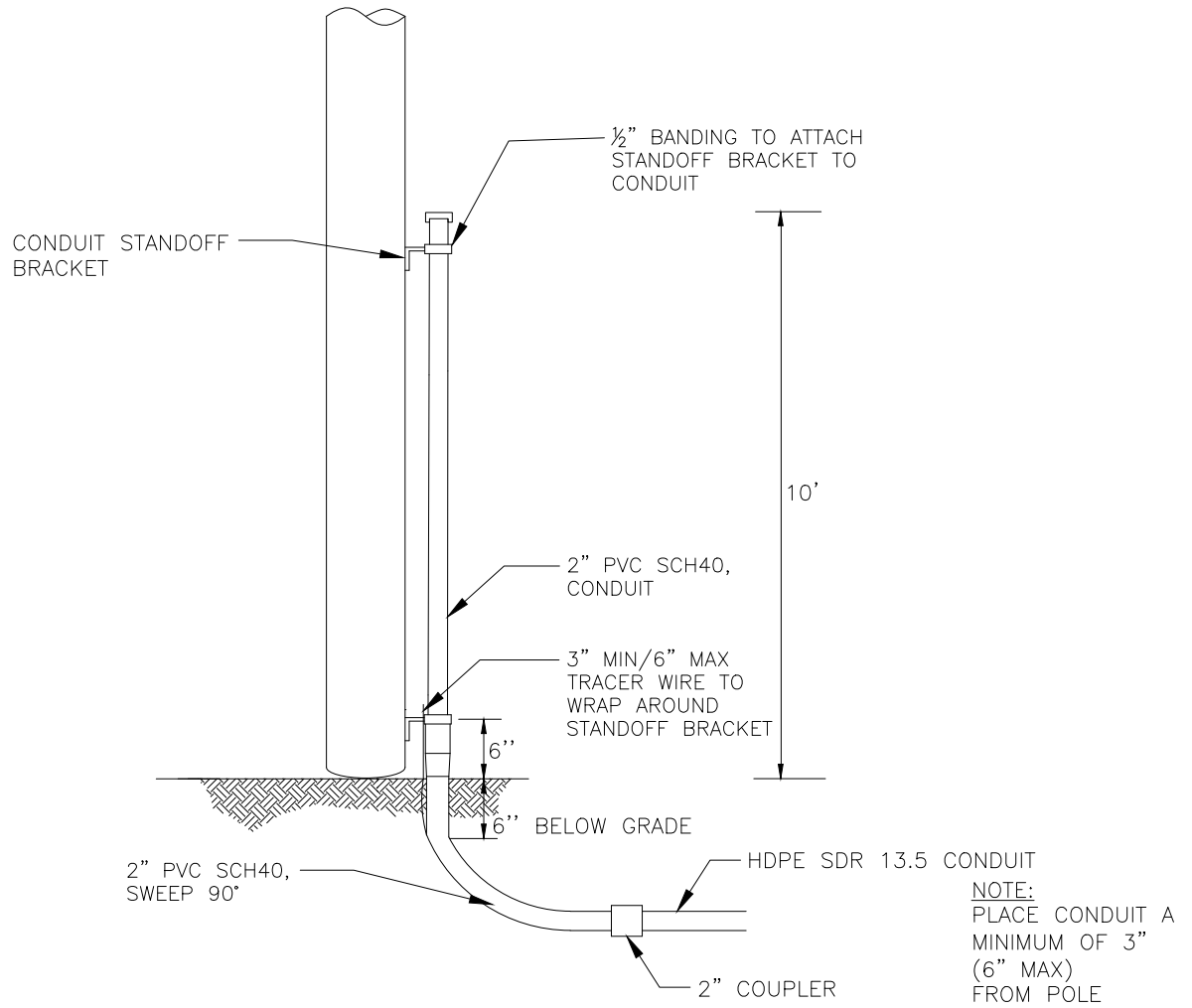

DESCRIPTION	QTY	MANUFACTURER (PREFERRED)	PART #
SCREW, LAG, 1/2" x 4-1/2"	10		
HDPE SDR 13.5 CONDUIT, VARIOUS SIZES	N/A		
2" PVC SCH40, RISER PIPE	1		
#12 TRACER WIRE	N/A		
2" PVC SCH40, SWEEP, 90 DEG	1		
CONDUIT STANDOFF BRACKET	VARIES		
CONDUIT STRAP KIT	VARIES		
2" COUPLER	1		



TYPICAL RISER
CONDUIT
WOOD POLE

(R2-W)

CONCEPTUAL SIDE VIEW

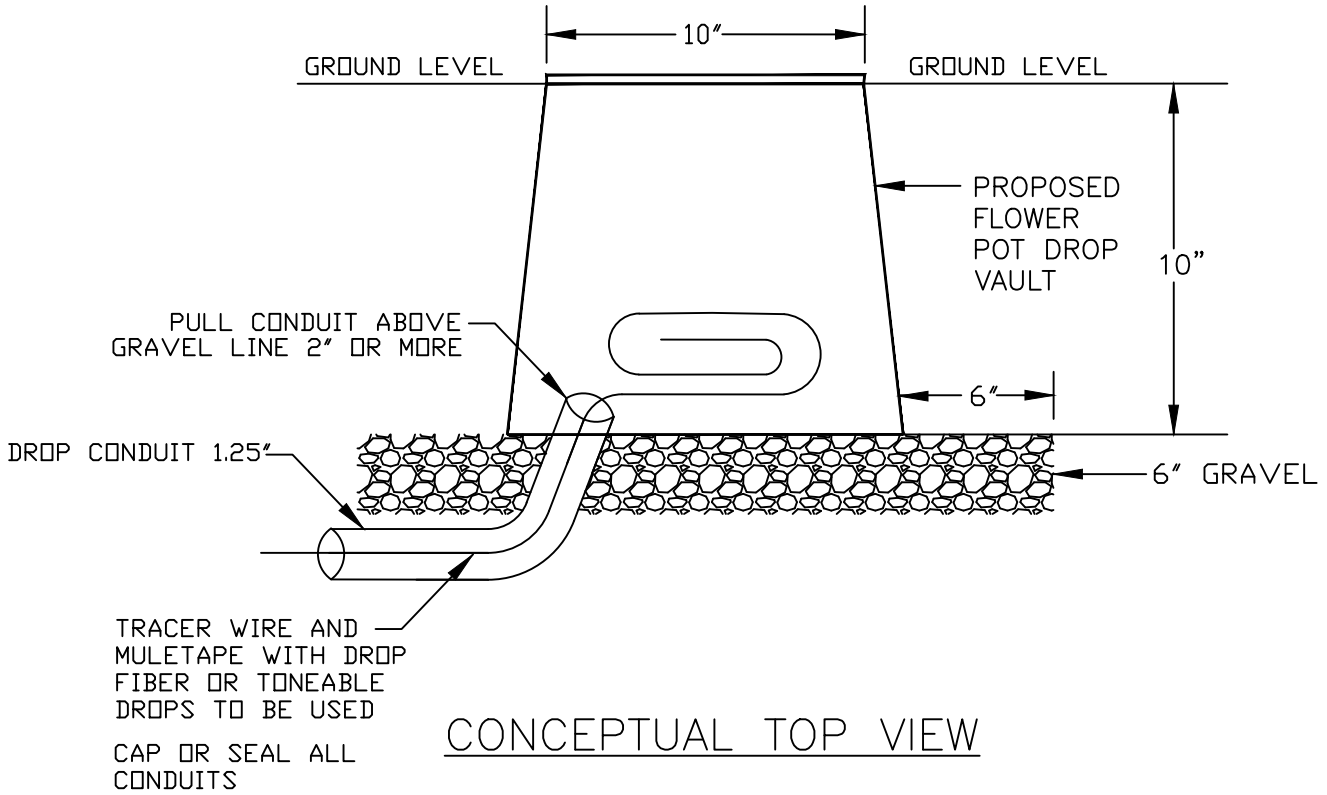

CONCEPTUAL TOP VIEW

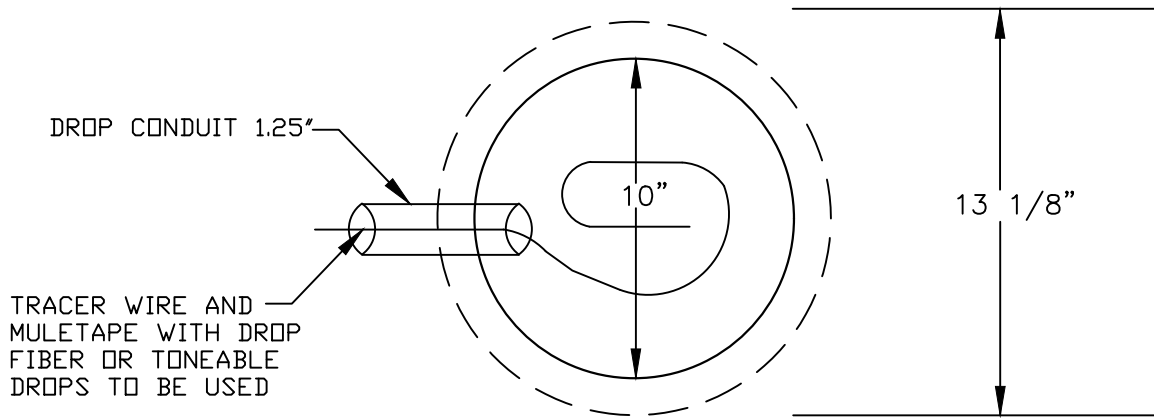

FLOWER POT

30"x48" PC UNIT, 2PC TIER 15/22
 18", 24", and 36" HEIGHT



AMERICAN POLYMER COMPANY

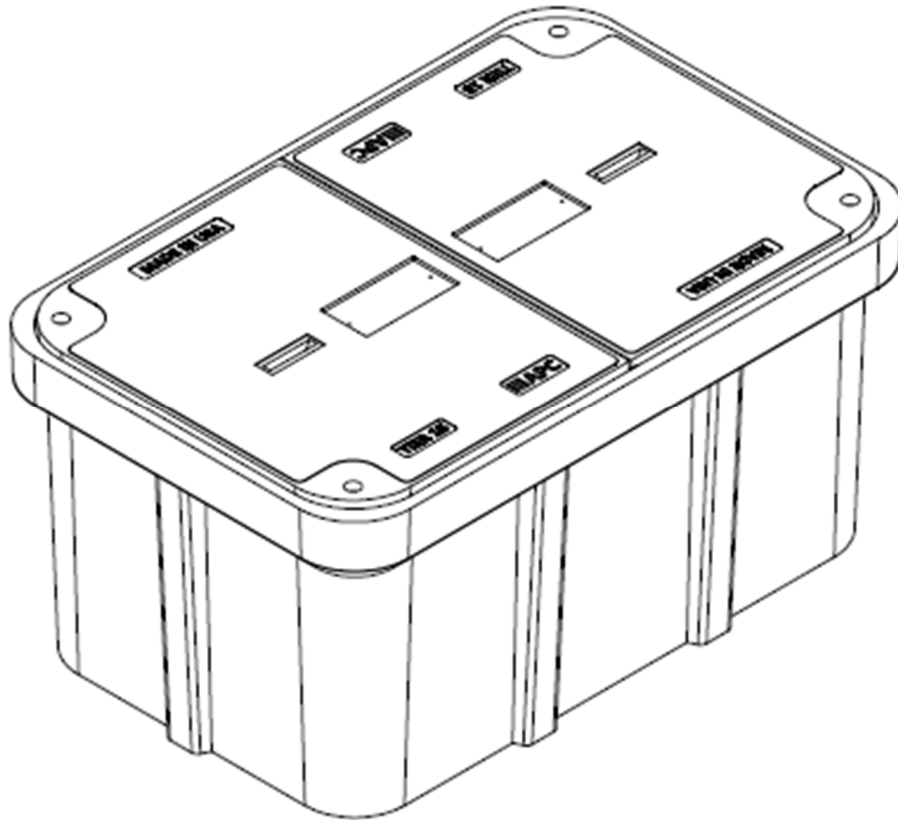

Description	Nominal Size	ANSI Tier	Part Number	Estimated Weight
PC Unit – TIER 15	30"x48"x18"	Tier 15	P304818HU15...	460 lbs.
PC Unit – TIER 22	30"x48"x18"	Tier 22	P304818HU22...	525 lbs.
PC Unit – TIER 15	30"x48"x24"	Tier 15	P304824HU15...	510 lbs.
PC Unit – TIER 22	30"x48"x24"	Tier 22	P304824HU22...	575 lbs.
PC Unit – TIER 15	30"x48"x36"	Tier 15	P304836HU15...	615 lbs.
PC Unit – TIER 22	30"x48"x36"	Tier 22	P304836HU22...	680 lbs.



30"x48" PC UNIT, 2PC TIER 15/22

18", 24", and 36" HEIGHT



AMERICAN POLYMER COMPANY

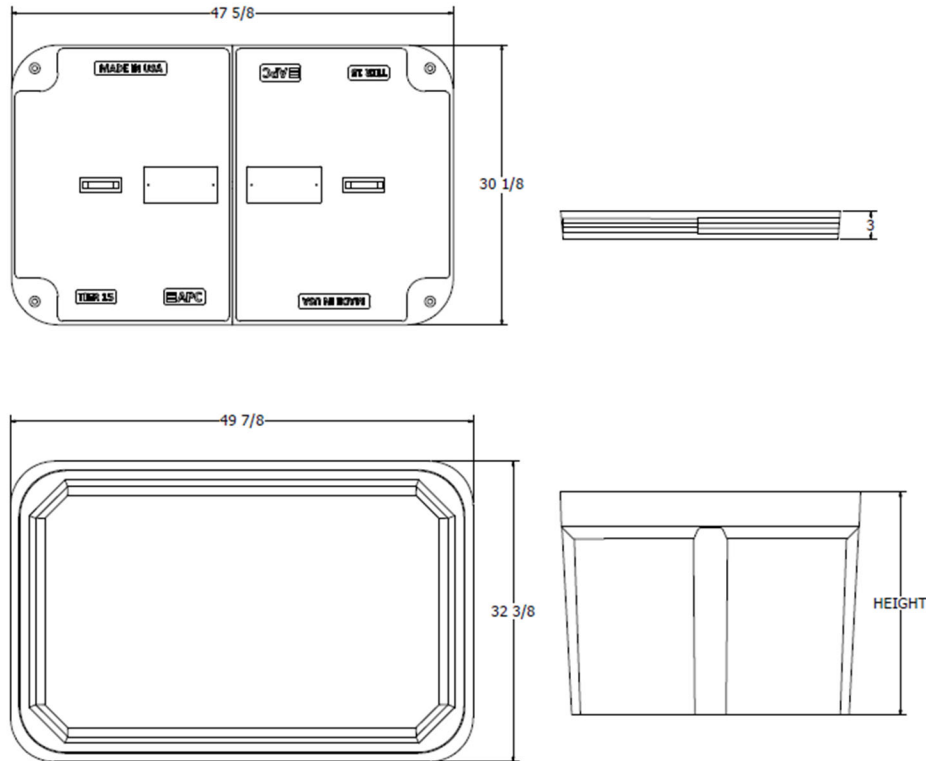

Components	Nominal Size	ANSI Tier	Part Number	Estimated Weight
Replacement Box	30"x48"x18"	Tier 22	P304818B22	185 lbs.
Replacement Box	30"x48"x24"	Tier 22	P304824B22	235 lbs.
Replacement Box	30"x48"x36"	Tier 22	P304836B22	340 lbs.
Replacement Lids - T15	30"x48" (half)	Tier 15	Various	150 lbs.
Replacement Lids - T22	30"x48" (half)	Tier 22	Various	170 lbs.

Bolt options



Machine Thread



Auger Thread



24"x36" PC UNIT, TIER 15/22
 18", 24", 30", and 36" HEIGHT



AMERICAN POLYMER COMPANY

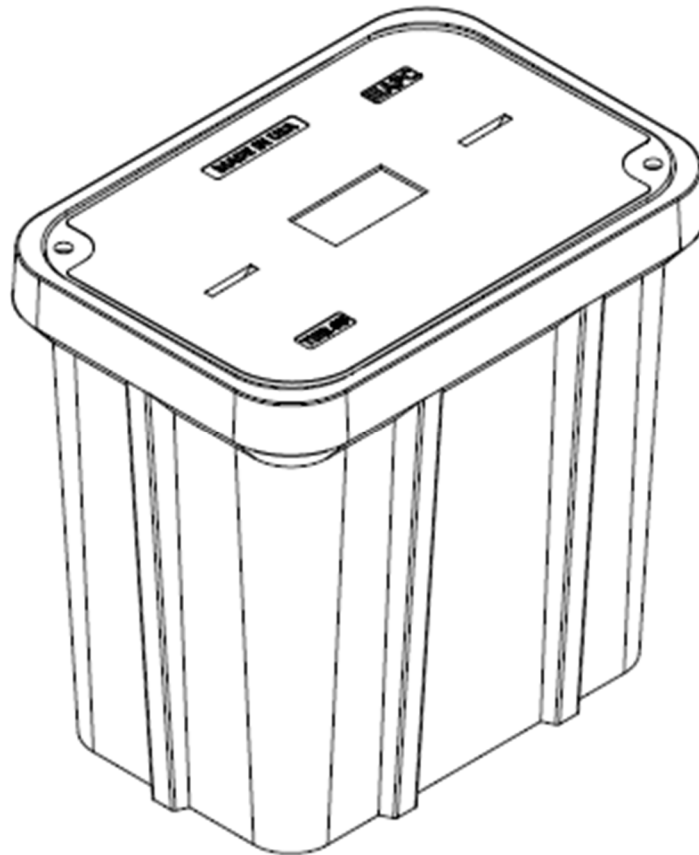

Description	Nominal Size	ANSI Tier	Part Number	Estimated Weight
PC Unit – TIER 15	24x36"x18"	Tier 15	P243618U15...	335 lbs.
PC Unit – TIER 22	24x36"x18"	Tier 22	P243618U22...	355 lbs.
PC Unit – TIER 15	24x36"x24"	Tier 15	P243624U15...	365 lbs.
PC Unit – TIER 22	24x36"x24"	Tier 22	P243624U22...	385 lbs.
PC Unit – TIER 15	24x36"x30"	Tier 15	P243630U15...	395 lbs.
PC Unit – TIER 22	24x36"x30"	Tier 22	P243630U22...	415 lbs.
PC Unit – TIER 15	24x36"x36"	Tier 15	P243636U15...	425 lbs.
PC Unit – TIER 22	24x36"x36"	Tier 22	P243636U22...	445 lbs.



24"x36" PC UNIT, TIER 15/22

18", 24", 30", and 36" HEIGHT



AMERICAN POLYMER COMPANY

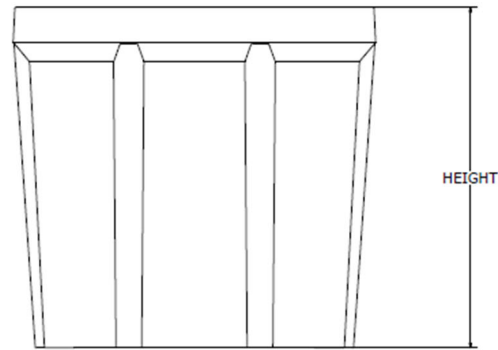
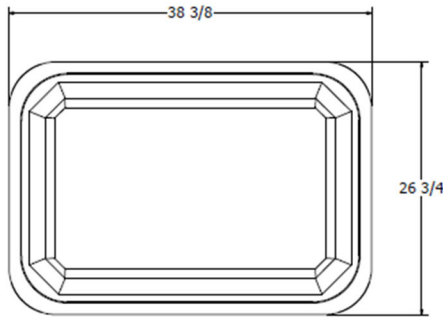
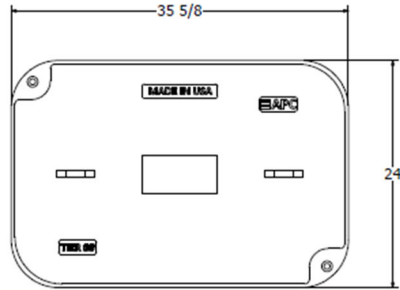

Components	Nominal Size	ANSI Tier	Part Number	Estimated Weight
Replacement Box	24"x36"x18"	Tier 22	P243618B22	165 lbs.
Replacement Box	24"x36"x24"	Tier 22	P243624B22	195 lbs.
Replacement Box	24"x36"x30"	Tier 22	P243630B22	225 lbs.
Replacement Box	24"x36"x36"	Tier 22	P243636B22	255 lbs.
Replacement Lids - T15	24"x36"	Tier 15	Various	170 lbs.
Replacement Lids - T22	24"x36"	Tier 22	Various	190 lbs.

Bolt options

Hex Head



Machine Thread



Penta Head



Auger Thread



17"x30" PC UNIT, TIER 15/22

12", 18", 24", and 30" HEIGHT



AMERICAN POLYMER COMPANY

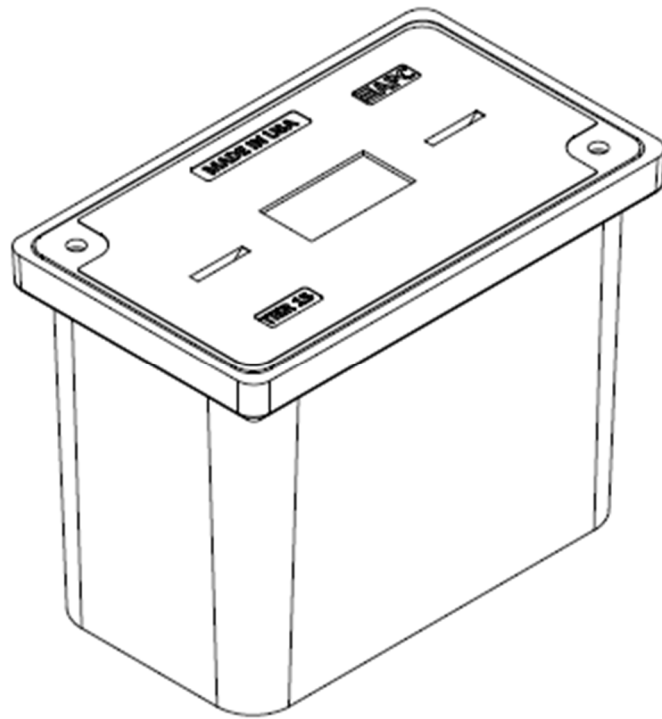

Description	Nominal Size	ANSI Tier	Part Number	Estimated Weight
PC Unit – TIER 15	17"x30"x12"	Tier 15	P173012U15...	138 lbs.
PC Unit – TIER 22	17"x30"x12"	Tier 22	P173012U22...	147 lbs.
PC Unit – TIER 15	17"x30"x18"	Tier 15	P173018U15...	172 lbs.
PC Unit – TIER 22	17"x30"x18"	Tier 22	P173018U22...	181 lbs.
PC Unit – TIER 15	17"x30"x24"	Tier 15	P173024U15...	192 lbs.
PC Unit – TIER 22	17"x30"x24"	Tier 22	P173024U22...	201 lbs.
PC Unit – TIER 15	17"x30"x30"	Tier 15	P173030U15...	217 lbs.
PC Unit – TIER 22	17"x30"x30"	Tier 22	P173030U22...	226 lbs.



17"x30" PC UNIT, TIER 15/22

12", 18", 24", and 30" HEIGHT



AMERICAN POLYMER COMPANY

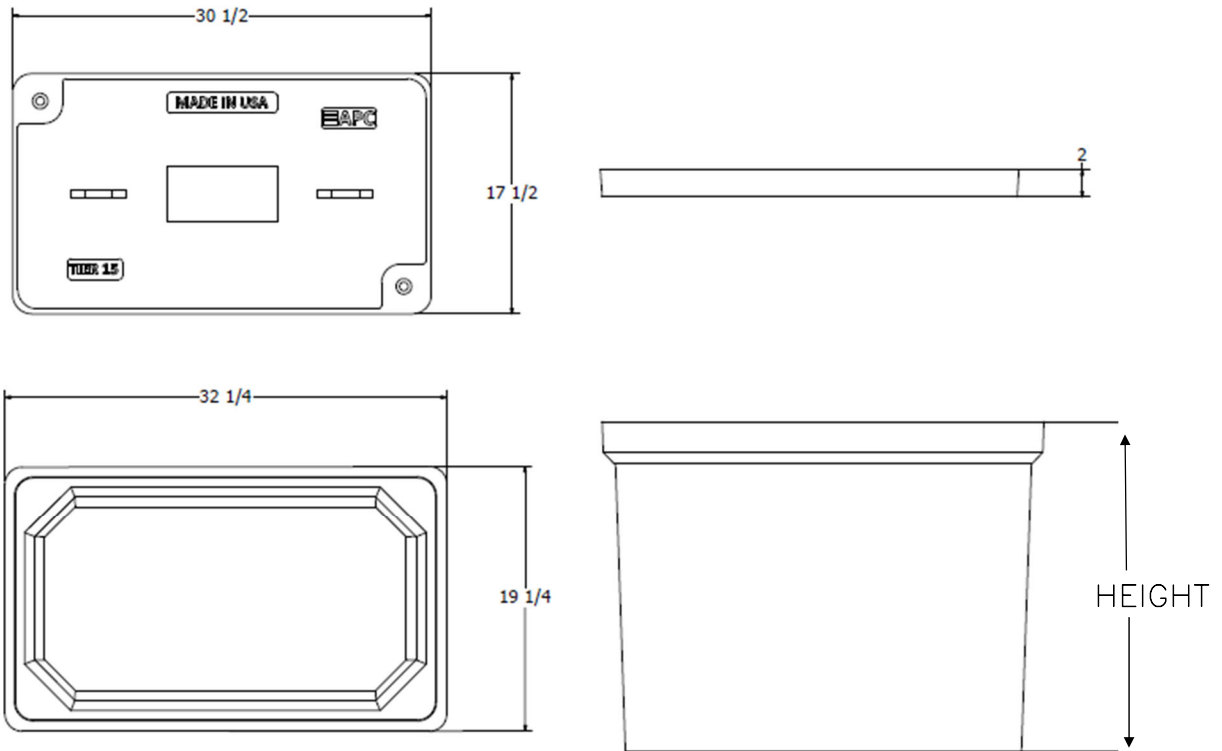

Components	Nominal Size	ANSI Tier	Part Number	Estimated Weight
Replacement Box	17"x30"x12"	Tier 22	P173012B22	66 lbs.
Replacement Box	17"x30"x18"	Tier 22	P173018B22	100 lbs.
Replacement Box	17"x30"x24"	Tier 22	P173024B22	120 lbs.
Replacement Box	17"x30"x30"	Tier 22	P173030B22	145 lbs.
Replacement Lids – T15	17"x30"	Tier 15	Various	72 lbs.
Replacement Lids – T22	17"x30"	Tier 22	Various	81 lbs.

Bolt options



Machine Thread



Auger Thread



33"x60" PC UNIT, 2PC TIER 15/22
36" HEIGHT



AMERICAN POLYMER COMPANY

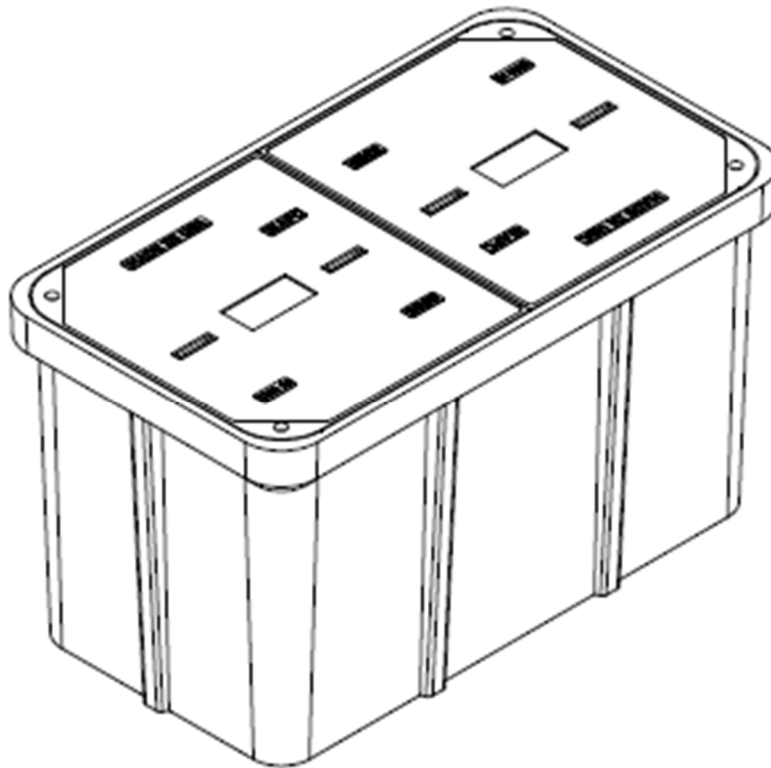

Description	Nominal Size	ANSI Tier	Part Number	Estimated Weight
PC Unit - TIER 15	33"x60"x36"	Tier 15	P336036U15...	930 lbs.
PC Unit - TIER 22	33"x60"x36"	Tier 22	P336036U22...	1030 lbs.



33"x60" PC UNIT, 2PC TIER 15/22

36" HEIGHT



AMERICAN POLYMER COMPANY

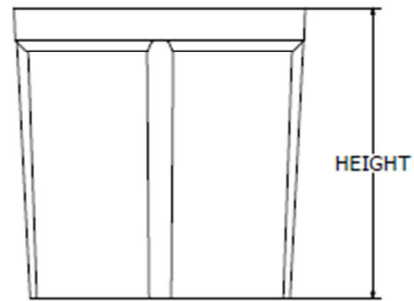
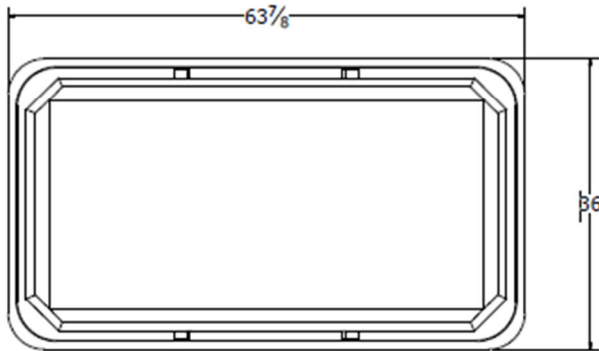
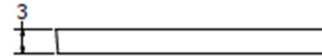

Components	Nominal Size	ANSI Tier	Part Number	Estimated Weight
Replacement Box	33"x60"x36"	Tier 22	P336036B22	530 lbs.
Replacement Lids - T15	33"x60" (half)	Tier 15	Various	200 lbs.
Replacement Lids - T22	33"x60" (half)	Tier 22	Various	250 lbs.

Bolt options

Hex Head



Machine Thread



Penta Head



Auger Thread



Speed (MPH) Prior To Road Work	SIGN SPACING, FT.		MUTCD Must be Approved by an Engineer				
	Non-Divided Highways	Divided Highways	BUFFER SPACE, FT.	TAPER LENGTH, FT.	Lane (12' R. Width)	Through Taper	Through Buffer/Work Area
	Length	Length	Shoulder (10 ft. Width)	Through Taper	Through Buffer/Work Area	Through Buffer/Work Area	
0-35	200	200	250	70	245	35	50
40-45	350	500	360	150	540	40	80
50-55	500	1000	495	185	660	50	100
60-70	SA-1000, SB-1500, SC-2640		730	235	840	60	120
Urban Low Speed - 100 FT							

APPROVED/ACCEPTED BY:
ENGINEER, OWNER, or PRIME CONTRACTOR
 Check for Notice to Proceed.

Signature: _____

Company: _____

Road Runner Safety Services, Inc.

Date: 4/25/2024 Project: BLC02a-F07 E Moody Dr ;
Traffic Control Suggestion For: ATLANTIC ENGINEERING (AEG) ;
By: Road Runner Safety Services, Inc. : Nathan

Comments:
Drawing not to scale. Traffic control plan must be approved by an engineer. This is a suggestion only. Road Runners Safety Services, Inc. has no liability for this suggested traffic control plan. Actual placement and spacing of all traffic control devices will depend on field conditions and must conform to MUTCD standards.

- Manifest**
- 6 x ADA Barricade
 - 1 x Arrow Board
 - 46 x Channelizer
 - 5 x End Construction
 - 2 x Flagger
 - 1 x Lane Ends (R)
 - 3 x No Parking
 - 2 x One Lane Road Ahead
 - 1 x Right Lane Closed Ahead
 - 10 x Road Construction Ahead
 - 5 x Sidewalk Closed
 - 5 x Sidewalk Closed Ahead Cross Here (R,L)
 - 1 x Sidewalk Closed Use Other Side

- Legend**
- ADA Barricade
 - Arrow Board
 - Channelizer
 - Conduit
 - Flagger (Person)
 - Sign
 - Vault
 - Work Area

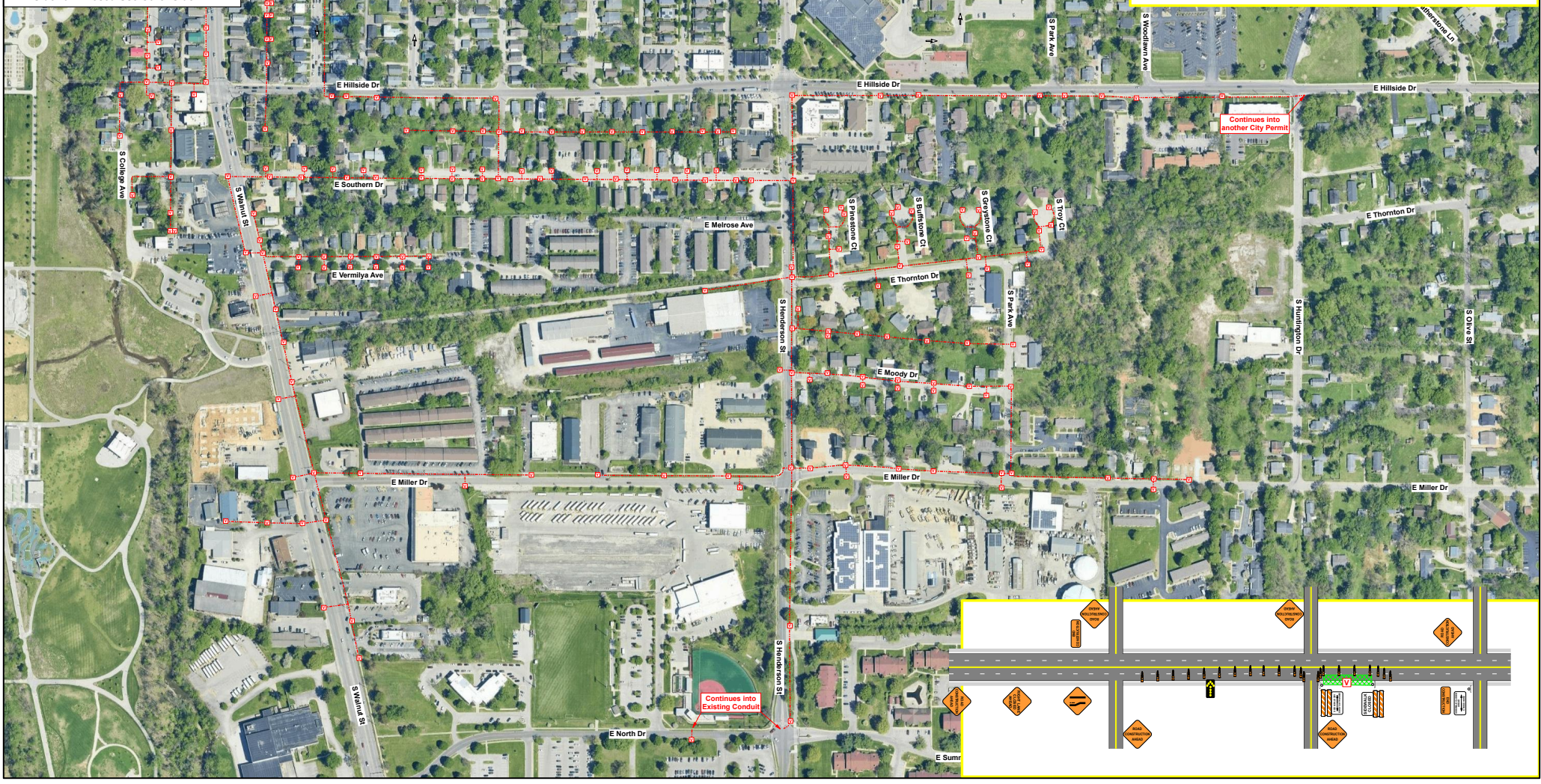

Work area will move along indicated lines.
Flagger setup to be used on residential 2 lane streets.
No parking setup to be used on one way streets.
Lane Closure shown below to be used on Walnut St.

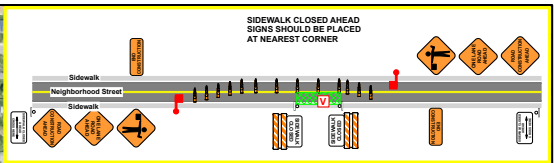

Continues into Existing Conduit

Continues into another City Permit



CITY OF BLOOMINGTON RIGHT-OF-WAY USE PERMIT APPLICATION

401 N Morton Street, Suite 130
P.O. Box 100
Bloomington, IN 47402

Phone: (812) 349-3913
Fax: (812) 349-3520
Email:
engineering@bloomington.in.gov

ROW EXCAVATION ROW USE

ADDRESS OF ROW ACTIVITY: _____

A. APPLICANT/AGENT INFORMATION: APPLICANT NAME: _____ E-MAIL: _____ COMPANY: _____ ADDRESS: _____ CITY, STATE, ZIP: _____ 24-HR EMERGENCY CONTACT NAME: _____ 24-HR CONTACT PHONE #: _____ INSURANCE #*: TB5-691-473497-082 COMPANY: ACORD BOND#*: _____ COMPANY: _____ <small>* INSURANCE & BOND MUST BE ON FILE WITH THE CITY BEFORE PERMIT WILL BE ISSUED</small>	D. TRAFFIC CONTROL DEVICES*: <input type="checkbox"/> CONES <input type="checkbox"/> ARROWBOARD <input type="checkbox"/> LIGHTED BARRELS <input type="checkbox"/> TYPE 3 BARRICADES <input type="checkbox"/> FLAGGERS <input type="checkbox"/> BPD OFFICER <small>*PROVIDING MUTCD COMPLIANT TEMPORARY TRAFFIC CONTROL DEVICES AND MAINTENANCE OF TRAFFIC (MOT) PLAN IS YOUR RESPONSIBILITY AND REQUIRED See page 3 for additional MOT resources; the graph paper can be used for your MOT site plan if needed or you can submit a separate sheet</small>
SUBCONTRACTOR INFORMATION (LIST ALL COMPANIES WORKING UNDER PRIMARY CONTRACTOR PERMIT) COMPANY NAME: _____	E. METERED PARKING SPACES NEEDED: <input type="checkbox"/> Y <input type="checkbox"/> N <small>IT IS THE RESPONSIBILITY OF THE APPLICANT TO RESERVE PARKING METER(S) APPLICATION LOCATED: https://bloomington.in.gov/transportation/parking/moving OR CONTACT PARKING SERVICES WITH QUESTIONS AT (812)349-3436</small>
B. WORK DESCRIPTION: <input type="checkbox"/> POD/DUMPSTER <input type="checkbox"/> CRANE <input type="checkbox"/> SCAFFOLDING <input type="checkbox"/> CONSTRUCTION USE* (EXPLAIN): _____ <small>*EXCAVATION, LONG TERM USE FOR STORAGE OF MATERIAL/EQUIPMENT/WALKAROUND</small>	F. IS THIS A <input type="checkbox"/> CBU* <input type="checkbox"/> COUNTY* <input type="checkbox"/> IU* <input type="checkbox"/> NP* PROJECT? PROJECT NAME: _____ PROJECT #: _____ PROJECT MGR.: _____ <small>*CBU = CITY OF BLOOMINGTON UTILITIES *COUNTY = MONROE COUNTY *IU= INDIANA UNIVERSITY *NP= NOT-FOR-PROFIT AGENCY</small>
C. RIGHT OF WAY TO BE USED/CLOSED: STREET NAME 1: _____ 1ST INTERSECTING STREET NAME: _____ 2ND INTERSECTING STREET NAME: _____ <input type="checkbox"/> ROAD CLOSURE <input type="checkbox"/> LANE CLOSURE 1 <input type="checkbox"/> 2 <input type="checkbox"/> 3 <input type="checkbox"/> <input type="checkbox"/> SIDEWALK* <input type="checkbox"/> BIKE LANE <input type="checkbox"/> OTHER TRANSIT STOP? <input type="checkbox"/> Y <input type="checkbox"/> N PARKING LANE(S)** <input type="checkbox"/> Y <input type="checkbox"/> N <small>**NON-METERED</small> START DATE: _____ END DATE: _____ # OF DAYS*: _____ STREET NAME 2: _____ 1ST INTERSECTING STREET NAME: _____ 2ND INTERSECTING STREET NAME: _____ <input type="checkbox"/> ROAD CLOSURE <input type="checkbox"/> LANE CLOSURE 1 <input type="checkbox"/> 2 <input type="checkbox"/> 3 <input type="checkbox"/> <input type="checkbox"/> SIDEWALK* <input type="checkbox"/> BIKE LANE <input type="checkbox"/> OTHER TRANSIT STOP? <input type="checkbox"/> Y <input type="checkbox"/> N PARKING LANE(S)** <input type="checkbox"/> Y <input type="checkbox"/> N <small>**NON-METERED</small> START DATE: _____ END DATE: _____ # OF DAYS*: _____ <small>*SIDEWALK CLOSURES FOR A PERIOD OR PERIODS TOTALING 24HRS OR MORE SHALL INSTALL A WALKAROUND UNLESS OTHERWISE APPROVED DURING REVIEW</small>	G. EXCAVATIONS: SQ FT OF PAVEMENT* EXCAVATIONS : _____ <small>*PAVEMENT INCLUDES: IN OR UNDER CONCRETE, OR ASPHALT INCLUDING CURBS</small> SQ FT OF NON-PAVEMENT* EXCAVATIONS: _____ <small>*DIRT, GRASS, GRAVEL, LANDSCAPE AREA OR OTHER UNPAVED SURFACE</small> LINEAL FT OF BORE*: _____ <small>*BORE PITS SHALL BE CALCULATED AS SQ FT EXCAVATIONS</small> # OF POLE INSTALLATIONS/REMOVAL: _____ SQ FT OF SIDEWALK RECONSTRUCTION*: _____ <small>*CONCRETE OR ASPHALT SIDEWALK/PATH BEING IMPROVED/REPLACED</small> SQ FT OF SIDEWALK NEW CONSTRUCTION*: _____ <small>*CONCRETE OR ASPHALT SIDEWALK/PATH THAT IS NEW INFRASTRUCTURE</small> #RESIDENTIAL DRIVEWAY INSTALLATION: _____
STANDARD CLOSURE HOURS MON-FRI*: 9:00 AM - 3:00 PM & 6:00 PM - 9:00 PM STANDARD CLOSURE HOURS <input type="checkbox"/> *NON-STANDARD CLOSURE HOURS <input type="checkbox"/> REQUESTED CLOSURE HOURS: _____ AM - _____ PM <small>*non-standard hours may not be allowed near schools, on arterials, or other circumstances and are subject to approval during the permitting process BMC 14.09.040 allows work from 6 AM to 10 PM without violating the noise ordinance (7AM to 9PM for pneumatic hammers)</small>	 TO SUBMIT A LOCATE REQUEST 24 HRS A DAY, 7 DAYS A WEEK CALL 811 OR 800-382-5544 CALL 2 WORKING DAYS BEFORE YOU DIG. ITS THE LAW.
H. INDEMNIFICATION AGREEMENT: <small>The petitioner/applicant hereby agrees to hold harmless, defend and to indemnify the City of Bloomington from or against all claims, action, damages and expenses, including but not limited to reasonable attorney's fees or any alleged injury and/or death to any person or damage to any property arising, or alleged to have arisen out of any act of commission or omission on the part of the petitioner/applicant, his/her heirs, successors, or assigns regardless of whether such acts are the direct or indirect result of the public right-of-way use pursuant to this permit grant.</small> I AFFIRM, UNDER THE PENALTIES FOR PERJURY, THAT THE FOREGOING REPRESENTATIONS ARE TRUE. PRINT NAME: _____ SIGNATURE: <u>Bret Simans</u> DATE: _____	

For Administration Use Only (applicable to CLOSURE approval)

Approved By: _____ BPW City Engineer Director Date: _____

Staff Representative: _____ Phone#: _____ Date: _____



Board of Public Works Staff Report

Project/Event:	Strauser Construction Upstairs Pub – West Bar Remodel
Staff Representative:	Kyle Baugh
Petitioner/Representative:	Ryan Strauser
Date:	May 6 th , 2024

Report: Strauser Construction is requesting lane and sidewalk closures during early morning hours on dates ranging from May 7, 2024, to August 10, 2024, on E Kirkwood Ave. The closures would be used for placing a crane in the metered parking spaces to hoist materials overhead into the Upstairs Pub. Lane closures will be implemented as needed if the crane supports encroach on the eastbound travel lane. Additionally, construction fencing is planned to be installed in the sidewalk area for material storage adjacent to the building. The lane and sidewalk closures are intended to be intermittent and will only be in effect during periods of material movement.

Strauser Construction has submitted the required maintenance of traffic plans detailing these arrangements. Because the closures will be short durations the sidewalk closure will be executed with signage at block ends and flaggers to direct pedestrian traffic across Kirkwood to the north sidewalk. Adjacent business owners have been made aware of the planned renovations.

Recommendation and Supporting Justification:

Staff has met Strauser Construction on site to discuss temporary traffic control and recommends granting permission for the temporary lane, sidewalk, and metered parking reservations on E Kirkwood Ave. The intermittent nature of the closures and the early morning schedule minimize the impact on traffic and pedestrian access, ensuring safety while facilitating necessary construction activities.

April 29, 2024

City of Bloomington - Board of Public Works

401 N. Morton Street
Bloomington, IN 47404

RE: Upstairs Pub – West Bar Renovation
430 E. Kirkwood Avenue
Bloomington, Indiana
Temporary ROW Use

Dear Board Members:

Strauser Construction Co., Inc. is the contractor for the Upstairs Pub – West Bar Renovation project at 430 E. Kirkwood Avenue. The project consists of structural and finish renovations to the western portion of bar, including removing the existing roof structure and raising it to a higher elevation.

As part of this project Strauser Construction Co. is requesting the following use of the ROW.

- 1) Use of parking space with meter #7618 from 5/6/2024 to 8/10/2024.
- 2) Use of the sidewalk and west bound traffic lane for 2 hour durations early in the morning on various days between 5/6/2024 and 8/10/2024 for hoisting of construction materials with a crane and forklift. This will not take place every day, but occur on various days as workflow progresses and dependent on weather conditions. During this time Strauser will install temporary sidewalk closed signs and provide flaggers so that traffic will not be entirely shut down along this segment of street.
- 3) Install a construction fence on the sidewalk, while maintaining a 4' clear width for pedestrian traffic from 6/1/2024 to 8/10/2024. This fence will be installed to keep pedestrians away from adjacent work overhead and its installation will be coordinated with the ground level retail tenant.

During the course of this project Strauser Construction Co., Inc. will work with the City of Bloomington and City of Bloomington Engineering to minimize disruptions caused by the project. Based on the attached information, Strauser Construction Co., Inc. request that the Board of Public Works approves the use of the right of way during the time periods stated above.

Sincerely,

Ryan M. Strauser

Ryan M. Strauser
RA, AIA, LEED AP

Strauser Construction Co., Inc.
453 S. Clarizz Blvd.
Bloomington, IN 47401

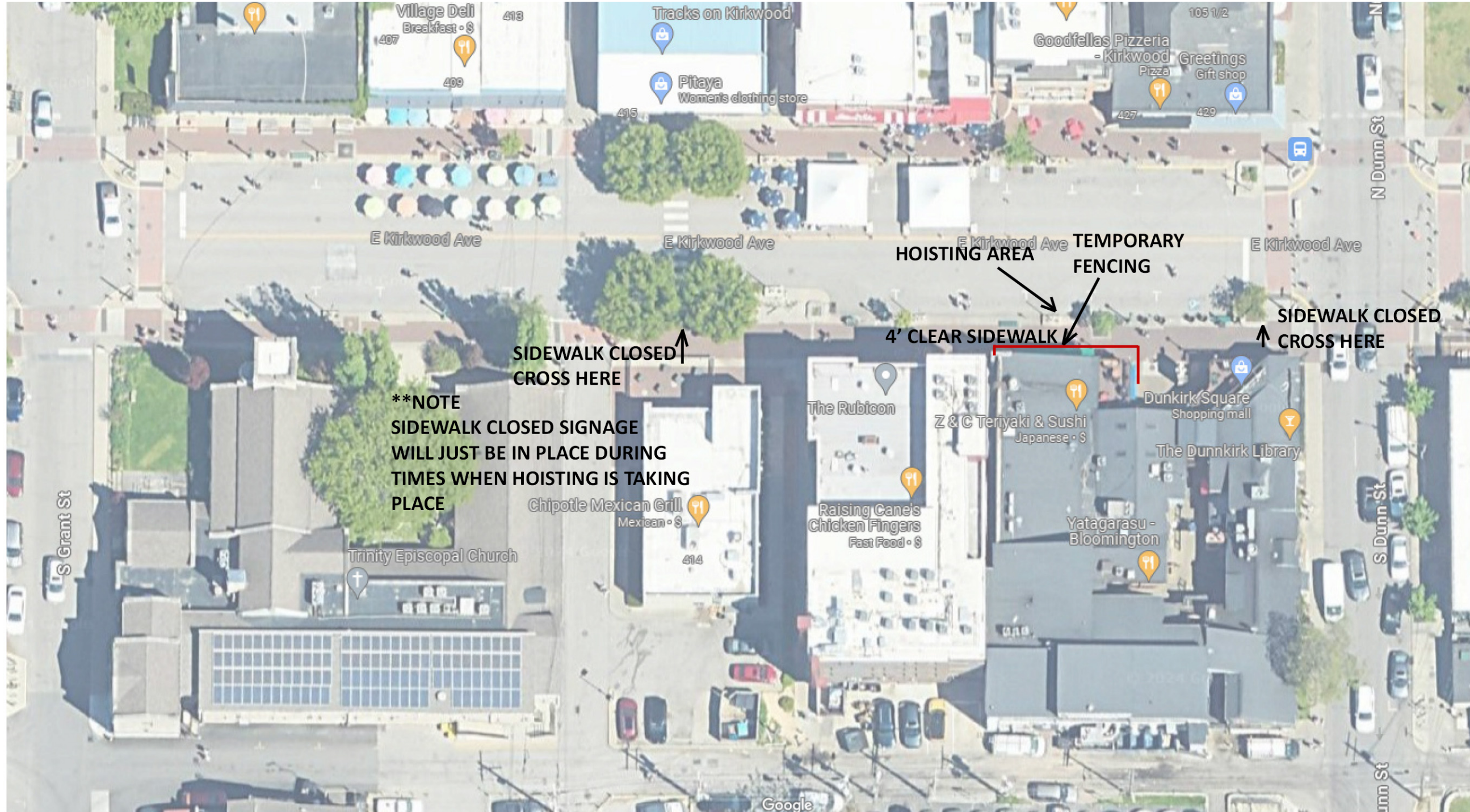

MOT PLAN



UPSTAIRS PUB - WEST BAR REMODEL
430 E. KIRKWOOD AVENUE

Figure 6H-10. Lane Closure on a Two-Lane Road Using Flaggers (TA-10)

Note: See Tables 6H-2 and 6H-3 for the meaning of the symbols and/or letter codes used in this figure.

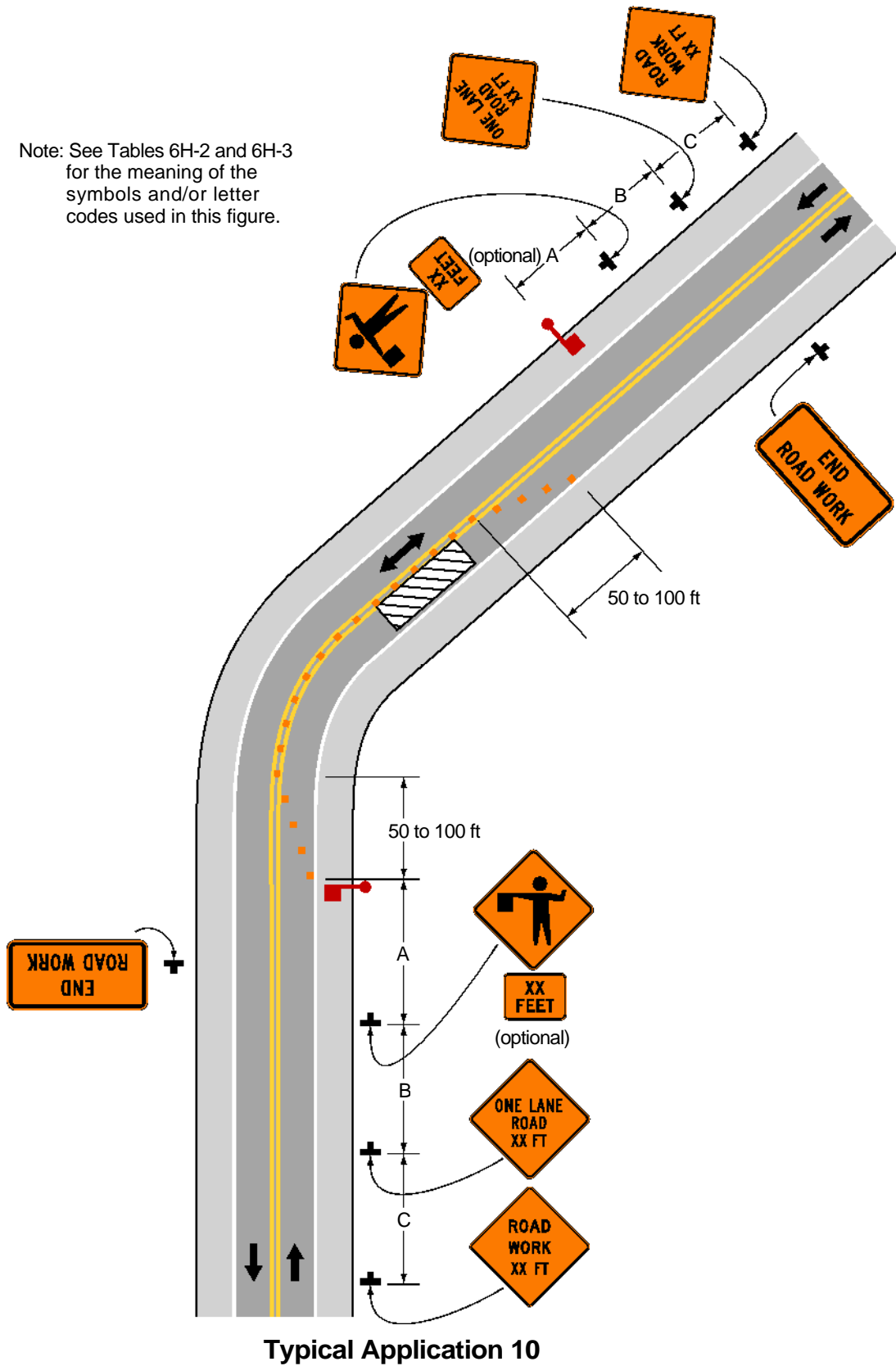



CITY OF BLOOMINGTON RIGHT-OF-WAY USE PERMIT APPLICATION

401 N Morton Street, Suite 130
P.O. Box 100
Bloomington, IN 47402

Phone: (812) 349-3913
Fax: (812) 349-3520
Email:
engineering@bloomington.in.gov

ROW EXCAVATION ROW USE

ADDRESS OF ROW ACTIVITY: 430 E. Kirkwood Ave., Bloomington, IN

A. APPLICANT/AGENT INFORMATION:		D. TRAFFIC CONTROL DEVICES*:	
APPLICANT NAME: <u>Strauser Construction Co., Inc.</u>		<input checked="" type="checkbox"/> CONES <input type="checkbox"/> ARROWBOARD	
E-MAIL: <u>rmstrauser@strausercci.com</u>		<input type="checkbox"/> LIGHTED BARRELS <input type="checkbox"/> TYPE 3 BARRICADES	
COMPANY: <u>Strauser Construction Co., Inc.</u>		<input checked="" type="checkbox"/> FLAGGERS <input type="checkbox"/> BPD OFFICER	
ADDRESS: <u>453 S. Clarizz Blvd.</u>		*PROVIDING MUTCD COMPLIANT TEMPORARY TRAFFIC CONTROL DEVICES AND MAINTENANCE OF TRAFFIC (MOT) PLAN IS YOUR RESPONSIBILITY AND REQUIRED. See page 3 for additional MOT resources; the graph paper can be used for your MOT site plan if needed or you can submit a separate sheet	
CITY, STATE, ZIP: <u>Bloomington, IN 47401</u>		E. METERED PARKING SPACES NEEDED: <input type="checkbox"/> Y <input checked="" type="checkbox"/> N	
24-HR EMERGENCY CONTACT NAME: <u>Ryan Strauser</u>		IT IS THE RESPONSIBILITY OF THE APPLICANT TO RESERVE PARKING METER(S) APPLICATION LOCATED: https://bloomington.in.gov/transportation/parking/moving OR CONTACT PARKING SERVICES WITH QUESTIONS AT (812)349-3436	
24-HR CONTACT PHONE #: <u>812-360-1503</u>		F. IS THIS A <input type="checkbox"/> CBU* <input type="checkbox"/> COUNTY* <input type="checkbox"/> IU* <input type="checkbox"/> NP* PROJECT?	
INSURANCE #*: _____ COMPANY: _____		PROJECT NAME: <u>Upstairs Pub - West Bar Remodel</u>	
BOND #*: _____ COMPANY: <u>Hylant -Nationwide</u>		PROJECT #:	
*INSURANCE & BOND MUST BE ON FILE WITH THE CITY BEFORE PERMIT WILL BE ISSUED		PROJECT MGR.:	
SUBCONTRACTOR INFORMATION		PROJECT MGR. #:	
(LIST ALL COMPANIES WORKING UNDER PRIMARY CONTRACTOR PERMIT)		*CBU = CITY OF BLOOMINGTON UTILITIES *COUNTY = MONROE COUNTY	
COMPANY NAME: <u>Strauser Construction Co.</u>		*IU= INDIANA UNIVERSITY *NP= NOT-FOR-PROFIT AGENCY	
B. WORK DESCRIPTION:		G. EXCAVATIONS:	
<input type="checkbox"/> POD/DUMPSTER <input type="checkbox"/> CRANE <input type="checkbox"/> SCAFFOLDING <input checked="" type="checkbox"/> CONSTRUCTION USE* Various small temporary closures of traffic lane with flaggers and (EXPLAIN): <u>closure of sidewalk to hoist materials into project area from ROW.</u>		SQ FT OF PAVEMENT* EXCAVATIONS : <u>NA</u>	
*EXCAVATION, LONG TERM USE FOR STORAGE OF MATERIAL/EQUIPMENT/WALKAROUND		*PAVEMENT INCLUDES: IN OR UNDER CONCRETE, OR ASPHALT INCLUDING CURBS	
C. RIGHT OF WAY TO BE USED/CLOSED:		SQ FT OF NON-PAVEMENT* EXCAVATIONS: <u>NA</u>	
STREET NAME 1: <u>E. Kirkwood Avenue</u>		*DIRT, GRASS, GRAVEL, LANDSCAPE AREA OR OTHER UNPAVED SURFACE	
1ST INTERSECTING STREET NAME: _____		LINEAL FT OF BORE*: <u>NA</u>	
2ND INTERSECTING STREET NAME: _____		*BORE PITS SHALL BE CALCULATED AS SQ FT EXCAVATIONS	
<input type="checkbox"/> ROAD CLOSURE <input checked="" type="checkbox"/> LANE CLOSURE 1 <input type="checkbox"/> 2 <input type="checkbox"/> 3 <input type="checkbox"/>		# OF POLE INSTALLATIONS/REMOVAL: <u>NA</u>	
<input checked="" type="checkbox"/> SIDEWALK* <input type="checkbox"/> BIKE LANE <input type="checkbox"/> OTHER		SQ FT OF SIDEWALK RECONSTRUCTION*: <u>NA</u>	
TRANSIT STOP? <input type="checkbox"/> Y <input type="checkbox"/> N PARKING LANE(S)** <input type="checkbox"/> Y <input type="checkbox"/> N **NON-METERED		*CONCRETE OR ASPHALT SIDEWALK/PATH BEING IMPROVED/REPLACED	
START DATE: <u>5/6/24</u> END DATE: <u>8/10/24</u> # OF DAYS*: <u>96</u>		SQ FT OF SIDEWALK NEW CONSTRUCTION*: <u>NA</u>	
Misc. use for small time intervals for hoisting of materials		*CONCRETE OR ASPHALT SIDEWALK/PATH THAT IS NEW INFRASTRUCTURE	
We will NOT be performing this work every day		#RESIDENTIAL DRIVEWAY INSTALLATION: <u>NA</u>	
STREET NAME 2: _____		TO SUBMIT A LOCATE REQUEST 24 HRS A DAY, 7 DAYS A WEEK, CALL 811 OR 800-382-5544. CALL 2 WORKING DAYS BEFORE YOU DIG. ITS THE LAW.	
1ST INTERSECTING STREET NAME: _____		H. INDEMNIFICATION AGREEMENT:	
2ND INTERSECTING STREET NAME: _____		The petitioner/applicant hereby agrees to hold harmless, defend and to indemnify the City of Bloomington from or against all claims, action, damages and expenses, including but not limited to reasonable attorney's fees or any alleged injury and/or death to any person or damage to any property arising, or alleged to have arisen out of any act of commission or omission on the part of the petitioner/applicant, his/her heirs, successors, or assigns regardless of whether such acts are the direct or indirect result of the public right-of-way use pursuant to this permit grant.	
<input type="checkbox"/> ROAD CLOSURE <input type="checkbox"/> LANE CLOSURE 1 <input type="checkbox"/> 2 <input type="checkbox"/> 3 <input type="checkbox"/>		I AFFIRM, UNDER THE PENALTIES FOR PERJURY, THAT THE FOREGOING REPRESENTATIONS ARE TRUE.	
<input type="checkbox"/> SIDEWALK* <input type="checkbox"/> BIKE LANE <input type="checkbox"/> OTHER		PRINT NAME: <u>Ryan M. Strauser</u>	
TRANSIT STOP? <input type="checkbox"/> Y <input type="checkbox"/> N PARKING LANE(S)** <input type="checkbox"/> Y <input type="checkbox"/> N **NON-METERED		SIGNATURE: <u>Ryan M. Strauser</u>	
START DATE: _____ END DATE: _____ # OF DAYS*: _____		DATE: <u>4/29/2024</u>	
*SIDEWALK CLOSURES FOR A PERIOD OR PERIODS TOTALING 24HRS OR MORE SHALL INSTALL A WALKAROUND UNLESS OTHERWISE APPROVED DURING REVIEW			
STANDARD CLOSURE HOURS MON-FRI*: 9:00 AM - 3:00 PM & 6:00 PM - 9:00 PM			
STANDARD CLOSURE HOURS <input type="checkbox"/> *NON-STANDARD CLOSURE HOURS <input checked="" type="checkbox"/>			
REQUESTED CLOSURE HOURS: <u>6:00</u> AM - <u>8:00</u> PM AM			
*non-standard hours may not be allowed near schools, on arterials, or other circumstances and are subject to approval during the permitting process			
BMC 14.09.040 allows work from 6 AM to 10 PM without violating the noise ordinance (7AM to 9PM for pneumatic hammers)			

For Administration Use Only (applicable to CLOSURE approval)

Approved By: _____ BPW City Engineer Director Date: _____

Staff Representative: _____ Phone#: _____ Date: _____



CITY OF BLOOMINGTON RIGHT-OF-WAY USE PERMIT APPLICATION

401 N Morton Street, Suite 130
P.O. Box 100
Bloomington, IN 47402

Phone: (812) 349-3913
Fax: (812) 349-3520
Email:
engineering@bloomington.in.gov

ROW EXCAVATION ROW USE

ADDRESS OF ROW ACTIVITY: 430 E. Kirkwood Ave., Bloomington, IN

A. APPLICANT/AGENT INFORMATION:		D. TRAFFIC CONTROL DEVICES*:	
APPLICANT NAME: <u>Strauser Construction Co., Inc.</u>		<input checked="" type="checkbox"/> CONES	<input type="checkbox"/> ARROWBOARD
E-MAIL: <u>rmstrauser@strausercci.com</u>		<input type="checkbox"/> LIGHTED BARRELS	<input type="checkbox"/> TYPE 3 BARRICADES
COMPANY: <u>Strauser Construction Co., Inc.</u>		<input checked="" type="checkbox"/> FLAGGERS	<input type="checkbox"/> BPD OFFICER
ADDRESS: <u>453 S. Clarizz Blvd.</u>		*PROVIDING MUTCD COMPLIANT TEMPORARY TRAFFIC CONTROL DEVICES AND MAINTENANCE OF TRAFFIC (MOT) PLAN IS YOUR RESPONSIBILITY AND REQUIRED. See page 3 for additional MOT resources; the graph paper can be used for your MOT site plan if needed or you can submit a separate sheet	
CITY, STATE, ZIP: <u>Bloomington, IN 47401</u>		E. METERED PARKING SPACES NEEDED: <input type="checkbox"/> Y <input checked="" type="checkbox"/> N	
24-HR EMERGENCY CONTACT NAME: <u>Ryan Strauser</u>		IT IS THE RESPONSIBILITY OF THE APPLICANT TO RESERVE PARKING METER(S) APPLICATION LOCATED: https://bloomington.in.gov/transportation/parking/moving OR CONTACT PARKING SERVICES WITH QUESTIONS AT (812)349-3436	
24-HR CONTACT PHONE #: <u>812-360-1503</u>		F. IS THIS A <input type="checkbox"/> CBU* <input type="checkbox"/> COUNTY* <input type="checkbox"/> IU* <input type="checkbox"/> NP* PROJECT?	
INSURANCE #*: _____ COMPANY: _____		PROJECT NAME: <u>Upstairs Pub - West Bar Remodel</u>	
BOND #*: _____ COMPANY: <u>Hylant -Nationwide</u>		PROJECT #:	
*INSURANCE & BOND MUST BE ON FILE WITH THE CITY BEFORE PERMIT WILL BE ISSUED		PROJECT MGR.:	
SUBCONTRACTOR INFORMATION		PROJECT MGR. #:	
(LIST ALL COMPANIES WORKING UNDER PRIMARY CONTRACTOR PERMIT)		*CBU = CITY OF BLOOMINGTON UTILITIES *COUNTY = MONROE COUNTY	
COMPANY NAME: <u>Strauser Construction Co.</u>		*IU= INDIANA UNIVERSITY *NP= NOT-FOR-PROFIT AGENCY	
B. WORK DESCRIPTION:		G. EXCAVATIONS:	
<input type="checkbox"/> POD/DUMPSTER <input type="checkbox"/> CRANE <input type="checkbox"/> SCAFFOLDING <input checked="" type="checkbox"/> CONSTRUCTION USE* (EXPLAIN): <u>Install temporary fencing in the ROW adjacent work area to keep pedestrians away from overhead work</u>		SQ FT OF PAVEMENT* EXCAVATIONS : <u>NA</u>	
*EXCAVATION, LONG TERM USE FOR STORAGE OF MATERIAL/EQUIPMENT/WALKAROUND		*PAVEMENT INCLUDES: IN OR UNDER CONCRETE, OR ASPHALT INCLUDING CURBS	
C. RIGHT OF WAY TO BE USED/CLOSED:		SQ FT OF NON-PAVEMENT* EXCAVATIONS: <u>NA</u>	
STREET NAME 1: <u>E. Kirkwood Avenue</u>		*DIRT, GRASS, GRAVEL, LANDSCAPE AREA OR OTHER UNPAVED SURFACE	
1ST INTERSECTING STREET NAME: _____		LINEAL FT OF BORE*: <u>NA</u>	
2ND INTERSECTING STREET NAME: _____		*BORE PITS SHALL BE CALCULATED AS SQ FT EXCAVATIONS	
<input type="checkbox"/> ROAD CLOSURE <input checked="" type="checkbox"/> LANE CLOSURE 1 <input type="checkbox"/> 2 <input type="checkbox"/> 3 <input type="checkbox"/>		# OF POLE INSTALLATIONS/REMOVAL: <u>NA</u>	
<input checked="" type="checkbox"/> SIDEWALK* <input type="checkbox"/> BIKE LANE <input type="checkbox"/> OTHER		SQ FT OF SIDEWALK RECONSTRUCTION*: <u>NA</u>	
TRANSIT STOP? <input type="checkbox"/> Y <input type="checkbox"/> N PARKING LANE(S)** <input type="checkbox"/> Y <input type="checkbox"/> N **NON-METERED		*CONCRETE OR ASPHALT SIDEWALK/PATH BEING IMPROVED/REPLACED	
START DATE: <u>6/1/24</u> END DATE: <u>8/10/24</u> # OF DAYS*: <u>70</u>		SQ FT OF SIDEWALK NEW CONSTRUCTION*: <u>NA</u>	
STREET NAME 2: _____		*CONCRETE OR ASPHALT SIDEWALK/PATH THAT IS NEW INFRASTRUCTURE	
1ST INTERSECTING STREET NAME: _____		#RESIDENTIAL DRIVEWAY INSTALLATION: <u>NA</u>	
2ND INTERSECTING STREET NAME: _____		TO SUBMIT A LOCATE REQUEST 24 HRS A DAY, 7 DAYS A WEEK CALL 811 OR 800-382-5544 CALL 2 WORKING DAYS BEFORE YOU DIG. ITS THE LAW.	
<input type="checkbox"/> ROAD CLOSURE <input type="checkbox"/> LANE CLOSURE 1 <input type="checkbox"/> 2 <input type="checkbox"/> 3 <input type="checkbox"/>		H. INDEMNIFICATION AGREEMENT:	
<input type="checkbox"/> SIDEWALK* <input type="checkbox"/> BIKE LANE <input type="checkbox"/> OTHER		The petitioner/applicant hereby agrees to hold harmless, defend and to indemnify the City of Bloomington from or against all claims, action, damages and expenses, including but not limited to reasonable attorney's fees or any alleged injury and/or death to any person or damage to any property arising, or alleged to have arisen out of any act of commission or omission on the part of the petitioner/applicant, his/her heirs, successors, or assigns regardless of whether such acts are the direct or indirect result of the public right-of-way use pursuant to this permit grant.	
TRANSIT STOP? <input type="checkbox"/> Y <input type="checkbox"/> N PARKING LANE(S)** <input type="checkbox"/> Y <input type="checkbox"/> N **NON-METERED		I AFFIRM, UNDER THE PENALTIES FOR PERJURY, THAT THE FOREGOING REPRESENTATIONS ARE TRUE.	
START DATE: _____ END DATE: _____ # OF DAYS*: _____		PRINT NAME: <u>Ryan M. Strauser</u>	
*SIDEWALK CLOSURES FOR A PERIOD OR PERIODS TOTALING 24HRS OR MORE SHALL INSTALL A WALKAROUND UNLESS OTHERWISE APPROVED DURING REVIEW		SIGNATURE: <u>Ryan M. Strauser</u>	
STANDARD CLOSURE HOURS MON-FRI*: 9:00 AM - 3:00 PM & 6:00 PM - 9:00 PM		DATE: <u>4/29/2024</u>	
STANDARD CLOSURE HOURS <input type="checkbox"/> *NON-STANDARD CLOSURE HOURS <input checked="" type="checkbox"/>			
REQUESTED CLOSURE HOURS: <u>24 hrs</u> AM - _____ PM			
*non-standard hours may not be allowed near schools, on arterials, or other circumstances and are subject to approval during the permitting process			
BMC 14.09.040 allows work from 6 AM to 10 PM without violating the noise ordinance (7AM to 9PM for pneumatic hammers)			

For Administration Use Only (applicable to CLOSURE approval)

Approved By: _____ BPW City Engineer Director Date: _____

Staff Representative: _____ Phone#: _____ Date: _____



Board of Public Works Staff Report

Project/Event: Kokosing Industrial Boring Project
Staff Representative: Kyle Baugh
Petitioner/Representative: Jerin Meredith
Date: May 6th, 2024

Report: Kokosing Industrial is requesting lane and sidewalk closures on E Morningside Drive from May 7, 2024, to May 17, 2024. This request is in connection with contracted work for the City of Bloomington Utilities to bore piping along the north sidewalk of Morningside Drive. The closures are necessary to facilitate the safe and efficient completion of the utility installation, which is critical for improving the city's infrastructure.

Kokosing Industrial has submitted all required maintenance of traffic plans for the project. These plans outline the methods for safely diverting both pedestrian and vehicular traffic around the work zone.

Recommendation and Supporting Justification: Staff has reviewed the request and recommends granting permission to Kokosing Industrial for the temporary traffic control on location.



- 50' sign spacing
- 50' taper distance both upstream and downstream using 20 cones
- Plan abides by ATSSA guides

Road Work ahead sign

One Lane Road Sign

Sidewalk Closed Sign

Flagger Ahead Sign

Type 3 Barricade

Road Work ahead sign

One Lane Road Sign

Flagger Ahead Sign

Work Zone

Flagger Ahead Sign

Sidewalk Closed Sign

One Lane Road Sign

Flagger Ahead Sign

Road Work ahead sign

One Lane Road Sign

E Saratoga Dr

Road Work ahead sign

S Park Ridge Rd

E Morningside Dr

E Indiana Bell Ct

- 50' sign spacing
- 50' taper distance both upstream and downstream using 20 cones
- Plan abides by ATSSA guides

SummerHouse at Indiana

College Mall Veterinary Hospital

Circle K Convenience store

Bruster's Real Ice Cream

Sare Associates

Board of Public Works Staff Report

Project/Event: Parking Garages Credit Card Processor Upgrade

Petitioner/Representative: PW Parking Services, Jess Goodman

Staff Representative: Jess Goodman

Date: 5.2.2024

Report:

The City of Bloomington Parking Garages pay equipment is in need of a new credit card processor. The garages current processor Payware will no longer be PCI compliant in the near future. Payware is also not compliant to our new software Miparc, which is being implemented mid-May so students can start applying and paying online. We have selected Windcave as our new processor. They are PCI compliant, and compatible with our new software. Evenstime (current parking equipment maintenance vendor) will be installing the new software and card readers along with Windcave in all Paying devices in the garages (pay lanes, and pay on foots). Windcave is a 2 year agreement with a monthly charge instead of a percentage. Once we go over the 12,000 transaction in a month it will be 0.05 per transaction. The average tickets sold per month is around 14,000. This will bring our bank fees from 14% to 11%. Once this is implemented customers can use third party vendors (ex. Park mobile) to pay their parking(SAP fee). This will also lower the bank charge cost and put it on the customer.

Consolidated Solution Gateway fee when on Windcave Merchant Services

Plan	Monthly Fee	Monthly Included Transactions	Per Transaction Overage Fee	Term
Buisness (A)	\$80.00	1,000	\$0.07	24 Months
Buisness (B)	\$350.00	5,000	\$0.06	24 Months
Corporate (A)	\$720.00	12,000	0.055	24 Months
Corporate (B)	\$1,250.00	25,000	\$0.05	24 Months
SAP*	\$5.00	Establishment	\$100.00	
PX C Corporate_Plan_3	\$2,500.00	50,000	\$0.05	

A one time set up fee of \$100.00 will apply for new accounts

Auth Fee – \$0.10
Discount Fee – 0.50%
Batch Fee – \$0.75
PCI Fee - \$20
Statement Fee - \$10
Chargeback Fee - \$25 (per occurrence)
User Fee- \$30.00 x's 5
 - Jessica McClellan (Controller)
 - Cheryl Gilliland (Deputy Controller)
 - Amy Silkworth (Accounts Revenue)
 - Jess Goodman (Parking Garage Manager)
 - Michelle Wahl (Parking Services Director)

Scope of Work:

- Get new terminal ID's from Windcave
- Evens Time installs new readers
- ID's are linked to each reader
- Sync devices to the server
- Test equipment

Project Estimated Cost: \$720.00 per month plus fees and .05 per transaction over the 12,000 transaction limit per month

Project Funding Source: 452-26-260000-53640 (Hardware and Software)



Recommend **Approval** **Denial by:** Jess Goodman

City of Bloomington Contract and Purchase Justification Form

Vendor: WindCave

Contract Amount: 720.00 per month + Fees

This form should be completed and attached to the contract documents and forwarded to the Legal Department Attorney assigned to your Department. Contracts will not be approved by the Controller if a completed form is not included with the contract documents.

PURCHASE INFORMATION

1. Check the box beside the procurement method used to initiate this procurement: (Attach a quote or bid tabulation if applicable)

<input type="checkbox"/> Request for Quote (RFQ)	<input type="checkbox"/> Request for Proposal (RFP)	<input checked="" type="checkbox"/> Sole Source	<input type="checkbox"/> Not Applicable (NA)
<input type="checkbox"/> Invitation to Bid (ITB)	<input type="checkbox"/> Request for Qualifications (RFQu)	<input type="checkbox"/> Emergency Purchase	

2. List the results of procurement process. Give further explanation where requested. Yes No

# of Submittals: 1	Yes	No	Was the lowest cost selected? (If no, please state below why it was not.)	<input type="checkbox"/>	<input checked="" type="checkbox"/>
Met city requirements?	<input checked="" type="checkbox"/>	<input type="checkbox"/>	Windcave was selected as a sole source since they already work with Evens Time the parking garage service maintance vendor. They are also compatible with the new credit card readers and third party vendors (parkmobile,miparc)		
Met item or need requirements?	<input checked="" type="checkbox"/>	<input type="checkbox"/>			
Was an evaluation team used?	<input type="checkbox"/>	<input checked="" type="checkbox"/>			
Was scoring grid used?	<input type="checkbox"/>	<input checked="" type="checkbox"/>			
Were vendor presentations requested?	<input type="checkbox"/>	<input checked="" type="checkbox"/>			

3. State why this vendor was selected to receive the award and contract:

Windcave was selected as a sole source since they already work with Evens Time the parking garage service maintance vendor. They are also compatible with the new credit card readers and third party vendors (parkmobile,miparc).

Jess Goodman

Parking Garage Manager

PW/Parking Services

Print/Type Name

Print/Type Title

Department

WINDCAVE AGREEMENT FOR CITY OF BLOOMINGTON

DATED this 25TH day of April 2024

PARTIES

WINDCAVE INC. (Windcave)

Contact Details for Notices:

Physical Address: 1601 N. 7th St., Suite 420, Phoenix, AZ 85006

Postal Address: 1601 N. 7th St., Suite 420, Phoenix, AZ 85006

Email: contracts@windcave.com

Phone: +1 310 670 7299

Fax: +1 310 670 7298

CustID: 124757

CITY OF BLOOMINGTON (Customer)

Contact Details for Notices: Jessica Goodman

Physical Address: 401 Morton St Bloomington IN 47404

Postal Address: 206 S Walnut Street Bloomington IN 47404

Email: goodmanj@bloomington.in.gov

Phone: 812-837-7837

Fax: N/A

AGREEMENT

1. Windcave is a provider of real time payment processing solutions in the USA. Windcave has agreed to supply solutions to Customer in accordance with the terms and conditions set out in this Agreement.
2. This Agreement is structured in two parts, namely Part A (Specific Terms) and Part B (General Terms). Part A contains the specific terms relevant to each supply of solutions to Customer and may include one or more Schedules. Part B sets out Windcave's general terms and conditions which will apply to all supplies of solutions.
3. It is intended that further supplies of solutions may be made and will be governed by this Agreement by way of the parties signing a further Part A Schedule for each supply. The attached schedules, or any schedules completed and signed after the date of this Agreement but referring to this Agreement, are a part of this Agreement. All purchase orders between the parties are subject to this Agreement's terms.
4. Windcave grants to Customer a non-exclusive, non-transferable licence to use the Windcave Solution for the Term solely for the purposes of the Permitted Use. Customer must not sub-license, transfer, assign, rent or sell the Windcave Solution or the right to use the Windcave Solution.

EXECUTION

SIGNED for and on behalf of **WINDCAVE INC.** by:

Signature

Name/Title

Date

SIGNED for and on behalf of **CITY OF BLOOMINGTON** by:

Signature

Name/Title (Director / Authorized Signatory)

Date

PART A – SPECIFIC TERMS

SCHEDULE 1 – SERVICES ACCESS ARRANGEMENT

1. SERVICES ACCESS ARRANGEMENT	
(a)	Windcave: Windcave grants to Customer a non-exclusive, non-transferable licence to use the Windcave Solution for the Term solely for the purposes of the Permitted Use. Customer must not sub-license, transfer, assign, rent or sell the Windcave Solution or the right to use the Windcave Solution.
2. TERM	
(a)	Commencement Date: May 14 th 2024 , Such Commencement Date may be postponed in writing, at Windcave’s sole discretion, until the date Windcave receives a copy of the Agreement countersigned by Customer.
(b)	Initial Term: 24 months beginning on the Commencement Date, unless earlier terminated under Part B, clause 12.
(c)	Renewal Term: 24 consecutive months, unless earlier terminated under Part B, clause 12, subject to automatic renewal pursuant to Part B, clause 2 if neither party gives three month’s advance notice of nonrenewal..
3. FEES	
(a)	Establishment Fee: \$100.00
(b)	Minimum Monthly Fee: \$350.00 per calendar month. Includes 5,000 Transactions per calendar month. Additional Transactions in each calendar month charged at the rate of \$0.06 per Transaction.
(c)	Additional Fees: Additional users to the Payment Manager can be set up, but will incur a one-time fee of \$30.00. If Windcave needs to configure or change additional electronic merchant numbers on the Windcave Host, there is a fee of \$100.00 per merchant account. Customer will be charged a \$5.00 SAP fee per calendar month charge per connected card reader for unattended and attended card reader devices.
(d)	Price Adjustment: Windcave shall have the right to vary the Fees enumerated in Part A of this Agreement during the Renewal Term of this Agreement by providing Customer at least 30 calendar days’ written notice before or during the Renewal Term. If Windcave exercises its right to modify the Fees, Customer shall thereafter have the right to terminate the Agreement with 30 days’ written notice to Windcave within 60 days of Windcave’s written notice that it is modifying the Fees.
4. PAYMENT TERMS	
(a)	Direct Debit or Automatic Credit Card Payments: Customer will pay Windcave the Fees by fees by Direct Debit or Automatic Credit Card on the dates specified below.
(b)	Due Date for Payment of Set Up Fees: Customer will pay Windcave the Establishment Fee immediately when Windcave makes the Windcave Solution available to customer.
(c)	Due Date for Payment of Monthly Fees and Additional Fees: Customer will pay Windcave the Monthly Fees and Additional Fees within 30 days of the date of Windcave’s invoice for those Fees
5. SUPPORT SERVICES	
(a)	Online Help and General Support: Windcave will provide the Support Services to Customer as set out in Part B.
(b)	Any special terms
6. SPECIAL CONDITIONS	
(a)	This agreement shall only apply to the City of Bloomington site located at 401 Morton St Bloomington IN 47404 CID 124757
7. EXECUTION	
The parties acknowledge and agree that this Schedule is governed by the Agreement between the parties containing Windcave’s General Terms and Conditions.	
SIGNED for and on behalf of WINDCAVE INC. by:	SIGNED for and on behalf of CITY OF BLOOMINGTON by:
_____	_____
Signature	Signature
_____	_____
Name/Title	Name/Title (Director / Authorized Signatory)
_____	_____
Date	Date

PART B – GENERAL TERMS & CONDITIONS

1.

2. Definitions and Interpretation (Not all defined terms are applicable to all goods and services provided under the Agreement)

1.1 Definitions: In this Agreement, unless the context indicates otherwise:

Acquirer means a bank or any financial institution or a card issuer of financial or non-financial transactions which receives and transmits Transactions via the Windcave Solution;

Agreement means this Agreement, including the Application Form, each of Part A and its Schedule(s) and Part B, and any attachments that may be agreed between the parties, as each may be amended in writing from time to time;

Application Form means Customer's online the Windcave Solution application form submitted to Windcave via the Windcave Website. Where no separate Part A is entered into, the Application Form will constitute Part A of this Agreement for the purposes of this Part B;

Business Day means any day of the week except Saturday, Sunday or a day on which banks are authorized or required to be closed in Arizona;

Chargeback means the procedure by which a sales record or other indicia of a card transaction (or disputed portion thereof) is denied or returned to Acquirer or the card issuer after it was entered into the appropriate settlement network for payment, in accordance with the rules of Visa, MasterCard or a similar card association ("Rules"), for failing to comply with the Rules, including, without limitation by reason of cardholder disputes, the liability for which is Customer's responsibility and Customer agrees to pay.

Commencement Date means the commencement date recorded in Part A in one or more Schedules; Such Commencement Date may be postponed in writing, at Windcave's sole discretion, until the date Windcave receives a copy of the Agreement countersigned by Customer.

Confidential Information means, in relation to either party, any information:

- (a) relating to the terms of this Agreement;
- (b) relating directly or indirectly to research or development by, accounting for, or the marketing of, the business of that party or its suppliers or customers;
- (c) disclosed by that party to the other party on the express basis that such information is confidential; or
- (d) which might reasonably be expected by the other party to be confidential in nature;

Customer means the customer specified in this Agreement and where applicable includes its employees, contractors and agents.

Default Interest Rate means interest at the rate of 2% above the base lending rate charged by Windcave's bankers to Windcave from time to time;

Delivery takes place when the Customer receives the Goods from Windcave, or, in the case of returns, when the Goods arrive at Windcave's premises;

Documentation means any user, training or system manuals for the Windcave Solution (whether in printed or electronic form) which describes and provides guidance on the use of the Windcave Solution (or any aspect of the Windcave Solution);

Emergency Support Services means telephone support that Windcave may provide (but is not obligated to provide unless it agrees to do so in a separate written agreement) for emergency breakdowns resulting in repeated failures in the transmission of Transactions and is available 24 hours a day, seven days a week by calling 310 670 7299 outside of Support Hours. If applicable, Windcave will use reasonable efforts to respond to any emergency phone call within 30 minutes of receiving the support request;

Fees means and includes each of the fees detailed in the Schedule(s) contained in Part A;

Goods means the Goods and/or Devices (if any) recorded in Part A in one or more Schedules;

Intellectual Property means registered and unregistered trade marks (including logos and trade files), domain names, copyright, patents, petty patents, utility models, registered and unregistered designs, circuit layouts, rights in computer software, databases and lists, Confidential Information, software (whether in object

code or source code), and all other rights anywhere in the world resulting from intellectual activity;

Payline Manager means Payline Portal which Customer is able to access by logging onto the Windcave Website with an assigned username and password;

PCI Standards means the Payment Card Industry standards, requirements and guidelines issued by the Payment Card Industry Data Security Council from time to time including the Payment Card Industry Data Security Standard PIN Entry Device requirements and guidelines, and the Payment Application Data Security Standard;

Permitted Use means the transmission to, and receipt from, an Acquirer of data relating to Windcave Supported Transactions and expressly excludes, without limitation, use for the processing of transactions of, or for the benefit of, any person other than Customer;

Security Standards means each of:

- (a) any data protection or data security standards issued by an Acquirer which receives and accepts Windcave Supported Transactions from Customer; and
- (b) the PCI Standards;

Software means the software and other related Windcave products which:

- (a) form part of the Windcave Solution; and
- (b) is owned or licensed by or developed by, or on behalf of, Windcave and supplied to Customer, including all upgrades, updates, alterations and modifications and other changes to such software by or on behalf of Windcave from time to time, but excluding any third party software and firmware forming part of, or supplied with, the Windcave Solution;

Special Conditions means the special conditions (if any) recorded in Part A in one or more Schedules;

Support Hours means the period from 8am to 9pm (PST) on any Business Day and 9am to 5pm (PST) on non-Business Days;

Support Services means and includes:

- (a) Online Help: from time to time Windcave may display Frequently Asked Questions and Answers on the Windcave Website;
- (b) General Support: enquiries may be sent to: support@windcave.com or made by telephone to 310 670 7299. Windcave will respond to such enquiries during Support Hours;

Term means the Initial Term recorded in Part A in one or more Schedules and includes any Renewal Terms as recorded in Part A in one or more Schedules and defined in clause 2(b);

Tokenized Data means data for which Windcave has substituted a sensitive data element with a non-sensitive equivalent that has no extrinsic or exploitable meaning or value; and

Transaction means a message pair consisting of a message relating to a Windcave Supported Transaction transmitted by Customer to an Acquirer through the Windcave Solution and a response to that message from the Acquirer to Customer through the Windcave Solution;

Windcave means Windcave Inc., a California corporation with offices in Phoenix, Arizona;

Windcave Host means the host server known as Windcave Host to which Customer may be connected using the Software and which is in turn linked to an Acquirer to enable Windcave Supported Transactions to be processed in real time;

Windcave Logo means the Windcave logo supplied (in electronic format) by Windcave to Customer (as may be updated from time to time by Windcave);

Windcave Solution means the solution provided by Windcave for the transmission of data relating to Windcave Supported Transactions between a Customer and an Acquirer, incorporating the Software and including access (via the internet) to the Windcave Host and the Support Services;

Windcave Supported Transactions means transactions from Customers:

- (a) accepting payment for goods and services by means of credit card, debit card, prepaid card, gift card or any other means of payment which Windcave agrees to support through the Windcave Solution from time to time;

- (b) accepting loyalty cards, rewards cards, points cards, discount cards or club cards; or
- (c) providing services in relation to the sale and use of any of the cards referred to in paragraphs (a) and (b) above including the issue of such cards and the crediting or debiting of value to such cards;

Windcave Website means the website maintained by Windcave and accessible by Customer for viewing Transactions, data entry, refunding, report generating and other features related to Transactions;

1.2 Interpretation: In this Agreement, unless the context indicates otherwise:

- (a) the singular includes the plural and vice versa;
- (b) clause and other headings are for ease of reference only and will not affect this Agreement's interpretation;
- (c) the term **includes** or **including** (or any similar expression) is deemed to be followed by the words without limitation;
- (d) references to a **person** include an individual, company, corporation, partnership, firm, joint venture, association, trust, unincorporated body of persons, governmental or other regulatory body, authority or entity, in each case whether or not having a separate legal identity;
- (e) any obligation not to do anything includes an obligation not to suffer, permit or cause that thing to be done;
- (f) all monetary amounts are stated exclusive of applicable taxes if any and in US dollars; and
- (g) in the event of any inconsistency between the terms of any of the following, they will have precedence in the descending order of priority set out below:
 - (i) Part A – Specific Terms and Schedules;
 - (ii) Part B – General Terms and Conditions;
 - (iii) The Application Form.

2. Term

2.1 Initial Term: This Agreement commences on the Commencement Date and will continue for the Initial Term, unless earlier terminated under Part B, clause 12.

2.2 Renewal: Upon expiry of the Initial Term, this Agreement will automatically continue for further periods of the number of consecutive months recorded in Part A in one or more Schedules (each such further period being a **Renewal Term**) on the same terms and conditions unless either party gives the other party not less than 3 months' notice in writing prior to the expiry of the Initial Term or the then current Renewal Term that it does not wish this Agreement to continue beyond the Initial Term or that Renewal Term as the case may be.

3. Payment

3.1 Fees: Customer will pay Windcave the Fees without setoff or deduction within 30 days of the date of Windcave's invoice for those Fees.

3.2 Taxes: Customer is responsible for all applicable taxes, duties and levies on the rental, loan or purchase or sale of goods and services (other than Windcave's income tax) assessed in connection with its use of the Windcave Solution and the provision of services under this Agreement. To the extent that any Fees paid by Customer under this Agreement exclude any taxes or duties payable in respect of the Goods or Services provided under this Agreement in the jurisdiction where the payment is either made or received, where any such taxes or duties are payable by Windcave, Customer agrees to pay to Windcave the amount of such taxes or duties in addition to any Fees owed under this Agreement. Notwithstanding the foregoing, you may have obtained an exemption from relevant taxes or duties as of the time such taxes or duties are levied or assessed. In that case, you will have the right to provide to Windcave with evidence of any such exemption information, in which case Windcave will use reasonable efforts to provide such invoicing documents as may enable you to obtain a refund or credit for the amount so paid from any relevant revenue authority if such a refund or credit is available.

3.3 Default Interest for Late Payment: Subject to Part B, clause 3.4(c)(ii), Customer must pay Windcave interest at the Default Interest Rate on any overdue amounts under this Agreement, calculated daily from the due date until the actual date of payment.

3.4 Disputed Invoices: Where Customer has reasonable grounds to dispute any portion of any amount invoiced by Windcave to Customer under this Agreement (**disputed portion**):

- (a) Customer will notify Windcave of such dispute and the grounds for such dispute within 5 Business Days of receiving the invoice;
- (b) any undisputed portion of the invoice will remain payable on the due date for payment;
- (c) provided that Customer has complied with clause 3.4(a), Customer will not be required to pay;

- (i) the disputed portion until the parties' dispute has been resolved by agreement between the parties or in accordance with Part B, clause 19.2; or
- (ii) any interest under clause 3.3 on the disputed portion unless the dispute is resolved with the effect that Customer is required to pay all (or part) of the disputed portion, in which case Customer will pay the interest on the disputed portion (or that part of that disputed portion) in accordance with clause 3.3. Interest will be payable from the date that payment would have been due under clause 3.1 but for the dispute until the date that disputed portion is paid to Windcave in full.

3.5 Termination and Suspension: If Customer does not timely pay Fees due and owing pursuant to this Agreement, Windcave may terminate this Agreement under Part B, Clause 12.2. Alternatively, Windcave may temporarily suspend the provision of the Windcave Solution to Customer. Customer agrees that Windcave will have no liability for such termination or suspension.

4. Mutual Responsibilities

Each party represents and agrees:

4.1 Power and Authority: that it has full power and authority necessary to validly enter into and perform all its obligations under this Agreement; and

4.2 Requirements: to comply with the other party's reasonable security, confidentiality and operational requirements of which it has been given reasonable notice.

5. Customer Responsibilities

Customer represents and agrees that it:

5.1 Suitability: has made, and will continue to make, its own assessment of the suitability, adequacy, compatibility and appropriateness of the Windcave Solution for its purposes;

5.2 Comply with Instructions: will comply with Windcave's restrictions, instructions and Documentation in relation to the use of the Windcave Solution, including those set out in this Agreement;

5.3 Use by Others: will ensure that only authorized persons use the Windcave Solution and that the Windcave Solution is used only for the Permitted Use and as expressly authorized under this Agreement;

5.4 Responsibility for Use: will accept all responsibility for the reliance on and use of the Windcave Solution by Customer and its employees, contractors and agents;

5.5 Obtain Equipment etc.: will obtain and maintain all equipment, software and services needed to enable it to receive and use the Windcave Solution;

5.6 Accurate Customer Information: warrants that all information provided by Customer to Windcave in the Application Form is accurate and correct, and that Customer will notify Windcave in writing if such information changes or ceases to be accurate in any way;

5.7 Provide Sufficient Information: will ensure that sufficient information is given to Windcave to enable Windcave to comply with its obligations under this Agreement and that such information is timely, complete and accurate;

5.8 Personal Information: acknowledges that any personal information concerning Customer or its personnel which is provided to Windcave by or on behalf of Customer may be:

- (a) used by Windcave for the purpose of providing the Windcave Solution, the Support Services and any other services to Customer; and
- (b) disclosed by Windcave to its affiliates and other services providers to enable Windcave to provide the Windcave Solution, the Support Services and any other services to Customer;

5.9 Notify of Third Party Infringement: will immediately notify Windcave upon becoming aware of any third party infringing Windcave's Intellectual Property rights in any manner;

5.10 Responsible for Connecting to Windcave Host: is responsible for all charges and costs associated with connecting to the Windcave Host to operate the Windcave Solution. Windcave will provide Customer with reasonable technical information and Software necessary to enable Customer to connect to the Windcave Host;

5.11 Requisite Review of Payline Portal: Customer shall be required, on a daily basis, to review with due care Customer's payline portal, established by Windcave, to review Transactions for errors. If an error is discovered by Customer, Customer must notify Windcave in writing within three (3) Business Days of the date an error occurs; provided, that Windcave will have no liability or obligations of any kind with respect to errors that are not reported to Windcave within such three (3) Business Day period. In addition, Customer shall be required to, on a daily basis review with due care bank settlement files to ensure deposits occur without error. If an error is

discovered by Customer, Customer must notify Windcave in writing within three (3) Business Days of the date an error occurs; provided, that Windcave will have no liability or obligations of any kind with respect to errors that are not reported to Windcave within such three (3) Business Day period. Windcave's liability under this Section 5.11 (Requisite Review of Payline Portal) of the Agreement is governed by, and fully subject to, the terms of Section 10 of this Agreement.

- 5.12 Comply with Law Generally:** will comply with all relevant laws in its use of the Windcave Solution and carrying out its obligations under this Agreement.
- 5.13 Improperly Deposited Funds:** will return funds that Windcave deposits in Customer's bank account(s) that do not rightfully belong to Customer ("Improperly Deposited Funds") without offset or delay. Customer will return all Improperly Deposited Funds to Windcave within five (5) calendar days of a written request to do so by Windcave. If Customer fails to comply with the terms of this Section, Windcave may immediately suspend services to Customer until Customer returns the Improperly Deposited Funds. Customer will be liable to Windcave for the Improperly Deposited Funds, and costs incurred by Windcave in recovering the Improperly Deposited Funds.
- 5.14 Return of Old Goods:** For Goods that Customer ceases using for the Permitted Use ("Unused Goods"), Customer will return such Unused Goods to Windcave within 30 calendar days. Unused Goods include, but are not limited to, Goods Customer has ceased using due to the Goods becoming obsolete, Goods that no longer operate, and Goods that are replaced per the warranty set forth in Part B, clause 7.3 of this Agreement. Customer will pay all shipping and restocking fees and costs associated with returning the Unused Goods to Windcave. Alternatively, instead of returning Unused Goods to Windcave, Customer may provide Windcave a secure destruction certificate evidencing that the Unused Goods were destroyed in compliance with the Security Standards within the same 30 calendar day period.

6. Windcave's General Responsibilities

Windcave agrees that it will:

- 6.1 Good Faith:** comply with all relevant laws and co-operate with Customer (and Customer's service providers) in connection with the Windcave Solution;
- 6.2 No Requirement to Decrypt Tokenized Data:** be under no obligation to decrypt and transmit Tokenized Data to Customer or any third party.

7. Windcave Warranties

7.1 Security Standards: Windcave confirms that Windcave will throughout the term of this Agreement comply with the requirements of the Security Standards.

7.2 Limitations on Warranties: To the fullest extent permitted by law, except as expressly set out in this Agreement, Windcave disclaims and excludes all warranties, conditions, terms, representations or undertakings, whether express, implied, statutory or otherwise, including any condition or warranty of merchantability or fitness for a particular purpose. Windcave does not warrant that:

- the Windcave Solution, the Goods, the Software or the Documentation will meet Customer's requirements; or
- the Windcave Solution the Goods, the Software and the Documentation will be uninterrupted or error free, or that all errors will be corrected; or
- that the Goods will be free of defects in design, materials or workmanship or will comply with any applicable equipment manufacturer's or software developer's specifications.

Customer understands and acknowledges that an authorization obtained through the Windcave Solution only confirms the availability of the cardholder's credit at the time of the authorization. It does not warrant that the person presenting the card is the rightful cardholder, nor is it an unconditional promise, guarantee or representation by Acquirer, processor or Windcave that a transaction is or will be deemed valid and not subject to dispute, debit or chargeback.

7.3 Supply Warranty: Windcave warrants that the Goods to be delivered under this Agreement will be free from defects in workmanship (labour and parts included, but transport excluded) during a warranty period commencing on the Commencement Date and concluding twelve (12) calendar months later ("Original Warranty Period"). As to repaired or exchanged Goods, during the Original Warranty Period here above mentioned, the warranty period on the exchanged or repaired Goods shall expire at the conclusion of the Original Warranty Period. With respect to Windcave's supply warranty:

- Any defective Goods, under warranty, shall be replaced or repaired, free of charge, at Windcave's discretion (to the exclusion of compensation for any other damage), and the work shall be carried out at Windcave or its partner's or subcontractor's premises. Customer will

pay the costs of transport of the Goods (including insurance) to Windcave.

- Windcave has the choice to repair the Goods with spare parts or new parts. The defective elements, repaired, will become the property of Windcave.
- The time when the Goods are repaired or unavailable during the warranty period will not give rise to an extension of the warranty period as set forth in this Section, subject to legal mandatory provisions.
- Customer must return warranted Goods that are replaced subject to this warranty back to Windcave within 30 calendar days of replacement Goods being shipped to Customer. Customer shall pay the shipping and restocking fees to return the old, warranted Goods back to Windcave.

7.4 Exclusions to Supply Warranty: Windcave will have no liability under the Supply Warranty described in Section 7.3 in respect of:

- Defects, breakdowns, or malfunctions due to failure to properly follow the installation process and instructions for use or an external cause to the Goods (including, but not limited to, shock, lightning fire, vandalism, malicious action, contacts with various liquids or vermin or water damage of any nature, and inappropriate electric voltage); or modifications to the Goods made without the written approval of Windcave; or a lack of every day maintenance (as described in the Documentation); or a lack of supervision or care; or improper storage or poor environmental conditions, particularly those related to temperature and hygrometry effects of variations of electric voltage from the electric network; or from the earth or repair work; or maintenance of the Goods by persons not authorized by Windcave;
- Damage due to insufficient or bad packaging of the Goods when returned to Windcave;
- Wear and tear from normal use of the Goods and accessories;
- Communication problems related to an unsuitable environment, including problems accessing the Internet, transmission faults, local network faults, and modification of the parameters of the relevant cellular network after sale of the Goods;
- Supply of new versions of Software. If, for example, Windcave produces new Software that is not necessary to fulfil its obligations under this Agreement, Windcave is not required to make such Software available to Customer;
- Malfunction due to the use of products or accessories that are non-compatible with the Goods;
- Goods returned to Windcave without Windcave's prior consent or that Windcave has not had an opportunity to troubleshoot;
- Defects, breakdowns, or malfunctions due to **obstructing material** being placed on or into the Goods. Examples of obstructing material include, but is not limited to, paper, plastic, and metal objects.

8. Intellectual Property

All Intellectual Property rights in the Windcave Solution, the Goods, the Software, the Documentation and any work or thing developed or created by or on behalf of Windcave under or in connection with this Agreement (such work or thing being **Developed Works**), are exclusively owned by Windcave (or Windcave's licensors or suppliers). Customer acknowledges that there is no transfer of title, Intellectual Property rights or ownership of:

- the Windcave Solution, the Goods, the Software, the Documentation or any part thereof; or
- any Developed Works; to Customer under this Agreement and Customer will not dispute Windcave's (or Windcave's licensors or suppliers) ownership of the property referred to in this clause 8.

9. Indemnity

Customer indemnifies Windcave at all times against any liability, loss, damage or cost (including attorney's fees) suffered or incurred by Windcave and all actions, proceedings, claims or demands made against Windcave as a result of any negligent act or omission or any breach of this Agreement by Customer, its personnel or agents.

10. Liability

To the fullest extent permitted by applicable law:

10.1 Remedy: Subject to clauses 10.2 and 10.3, Customer's sole and exclusive remedy for breach of any warranty or of any of Windcave's obligations under this Agreement is (at Windcave's option) the supply or re-supply of the Windcave Solution, the Goods, the Software, or the Documentation or the refund or waiver of Fees for the relevant part of the Windcave Solution, the Goods, the Software, or the Documentation which is the subject matter of, or directly related to, the breach.

10.2 Limitation: In no event will Windcave's total liability to Customer under this Agreement for any one or more defaults as described in clause 10.1 exceed the amount paid by Customer to Windcave under this Agreement in the 3 months following execution of this Agreement.

10.3 Exclusion: In no event will Windcave be liable to Customer whether in contract, tort (including negligence) or otherwise in respect of any:

1. punitive, incidental, indirect or consequential damages, damages for loss of profits, business interruption, loss of data, loss of goodwill, arising out of, or in connection with, this Agreement, in each case even if such party has been advised of the possibility of such damages;
2. loss, damage, cost or expense suffered or incurred by Customer, to the extent this results from any act or omission by Customer; or
3. any event described in Part B, clause 14 (Force Majeure).

11. Commercial Purpose

It is expressly acknowledged and agreed by Customer that the Windcave Solution, the Goods, the Software and the Documentation are supplied to Customer for business and commercial purposes.

12. Termination

12.1 Termination Upon Notice:

- (a) Windcave may terminate this Agreement at any time on not less than 3 months' prior written notice to Customer.
- (b) Customer may terminate this Agreement at any time on not less than 3 months' prior written notice to Windcave, provided:
 1. During the Initial Term, Customer will be liable for the Fees for the remainder of the Term, which, notwithstanding clause 3.1, shall be payable immediately on giving such notice;
 2. During any Renewal Term, Customer will be liable for the Fees for the remainder of the Term, which, notwithstanding clause 3.1, shall be payable immediately on giving such notice.

12.2 Termination for Cause: Either party (the **First Party**) may terminate this Agreement at any time and with immediate effect by written notice to the other party (**Second Party**) if the **Second Party**:

- (a) is in material breach of any of its obligations under this Agreement, and has failed to remedy the breach within 10 Business Days of receiving written notice from the **First Party** to remedy the breach; or
- (b) goes into voluntary or involuntary bankruptcy or liquidation or has a receiver appointed; or
- (c) is unable to pay its debts as they fall due.

12.3 Breach of License Terms: Without limiting clause 12.2, any use of the Windcave Solution, the Goods, the Software, or the Documentation by Customer for any purpose other than the Permitted Use, or any breach by Customer of the provisions of Part B, clause 16 will be deemed to be a material breach of this Agreement which is not reasonably capable of remedy.

12.4 Consequences:

- (a) Amounts owing at termination: If this Agreement is terminated by Windcave for cause prior to the expiry of the Term, Customer must pay the unpaid balance of the Fees due under this Agreement and the cost of Windcave's reasonable expenses resulting from Customer's breach of this Agreement.
- (b) Expiry or termination of this Agreement will not affect the rights or obligations of the parties which have accrued prior to or accrue on termination or which by their nature are intended to survive termination (including Part B, clauses 3, 5, 7, 8, 9, 10, this 12.4, 13, 16, 17 and 19, together with those clauses which are incidental to, and required in order to give effect to, those clauses).

13. Confidentiality

13.1 Confidential Information: Each party will maintain as confidential at all times, and will not at any time, directly or indirectly:

- (a) disclose or permit to be disclosed to any person;
- (b) use for itself or to the detriment of the other party;

any Confidential Information of the other party except as, and then only to the extent:

1. required by law;
2. that the information is already or becomes public knowledge, otherwise than as a result of a breach, by the receiving party, of any provision of this Agreement;
3. that the information is disclosed to the receiving party, without restriction, by a third party and without any breach of confidentiality by the third party;

4. that the information is developed independently by the receiving party without reliance on any of the Confidential Information of the other party;
5. authorized in writing by the other party; or
6. reasonably required by this Agreement (and, without limiting the effect of this clause, a party may disclose Confidential Information of the other party only to those of its officers, employees or professional advisers on a "need to know" basis, as is reasonably required for the implementation of this Agreement).

13.2 Windcave's Intellectual Property: Customer acknowledges and agrees that the computer programs, computer software, specifications, databases, images, designs, codes, and configurations, ("Software") contained in or utilized by the Equipment and Windcave's network are proprietary and confidential to Windcave and protected under United States copyright law. Customer shall not copy, modify, adopt, translate, merge, reverse engineer, decompile, or disassemble, the equipment or Software, or create any derivative works based on the Equipment, Windcave network or Software. Without limiting the effect of clause 13.1, Customer will treat information about Windcave's Intellectual Property as the Confidential Information of Windcave.

14. Force Majeure

14.1 Customer acknowledges that Windcave relies on third-party providers in the delivery of its services, including, but not limited to, wireless data network providers, cellular radio service provided by third parties that is available only when within the operating range of cellular systems, and cellular service is subject to transmissions limitations and dropped or interrupted transmissions. Cellular service may be temporarily refused, limited, interrupted, or curtailed because of government regulations or orders, atmospheric and/or topographical conditions, and cellular system modifications, repairs, and upgrades. Customer agrees that Windcave shall not be liable for, and to hold Windcave harmless for any losses, damages, or business interruptions sustained as a result of interruptions caused by its wireless data network providers or any other third-party provider.

14.2 Neither party (the "**Affected Party**") shall be liable for any default or delay in the performance of its obligations under this Agreement if and to the extent such default or delay is caused, directly or indirectly, by

- (a) fire, flood, elements of nature or other acts of God;
- (b) any outbreak or escalation of hostilities, war, riots or civil disorders in any country;
- (c) any act or omission of the other party or any government authority;
- (d) any labor disputes (whether or not employees' demands are reasonable or within the party's power to satisfy); or
- (e) the nonperformance by a third party for any similar cause beyond the reasonable control of such party, including without limitation, failures or fluctuations in telecommunications or other equipment such as described in clause 14.1.

14.3 In any such event, the **Affected Party** shall be excused from any further performance and observance of the obligations so affected only for as long as such circumstances prevail and such party continues to use commercially reasonable efforts to recommence performance or observance as soon as practicable, provided that:

- (a) Notice: whenever the **Affected Party** becomes aware that such a result has occurred or is likely to occur, the **Affected Party** will, as soon as practicable, notify the other party by written notice accordingly;
- (b) Continued Performance: each party will continue to use commercially reasonable efforts to perform its obligations as required under this Agreement; and
- (c) No Deemed Acceptance of Extra Costs: neither party will be deemed to have accepted any liability to pay or share any extra costs which may be incurred by the other party in complying with this clause or otherwise resulting from such act, omission or failure; and
- (d) Charges: this clause 14 will not apply in respect of Customer's obligation to pay any charges or Fees payable under this Agreement.

15. License

15.1 Grant of License: Windcave grants to Customer a non-exclusive, non-transferable license to use the Windcave Solution, the Goods, the Software and the Documentation for the Term of this Agreement solely for the Permitted Use. Any other use or dealings with the Windcave Solution, the Goods, the Software or the Documentation without the prior written consent of Windcave will be a material breach of this Agreement. Except to the extent specifically authorized under this Agreement, Customer must not sublicense, transfer, assign, rent or sell any of the Windcave Solution, the

Goods, the Software or the Documentation or the right to use the Windcave Solution, the Goods, the Software or the Documentation.

15.2 Windcave Warranty: Windcave warrants that Windcave has the right and authority to grant to Customer the license set out at clause 15.1, in accordance with the terms of this Agreement.

16. Terms of Use

16.1 Adequacy: Customer must satisfy itself as to the adequacy, appropriateness and compatibility of the Windcave Solution and/or the Goods for its requirements. Without limiting the foregoing, Customer acknowledges that it has not relied on any statements or representations on the part of Windcave as to performance or functionality, verbal or otherwise, except as expressly recorded in this Agreement.

16.2 Windcave Logo: If Customer uses a capture method for credit or debit card processing using a system which is not hosted by Windcave, Customer agrees to display the Windcave Logo in a readily visible position on the user interface of Customer's system where the credit or debit card data is captured. The Windcave Logo must not be altered or used for any other purpose without the prior written consent of Windcave.

16.3 Compliance: If Customer is not compliant with one or more of the Security Standards, Customer must not capture or store any credit or debit card number or expiry date locally on Customer's or a non-compliant third party's system.

16.4 No Right to Copy, Alter or Modify: Customer may make a reasonable number of copies of the Software for backup and disaster recovery purposes only. Except for such back-up copies, Customer must not, and must not permit any other person to, copy, reproduce, translate, adapt, vary, repair or modify all or any part of the Windcave Solution, the Goods, the Software or the Documentation by any means or in any form without Windcave's prior written consent.

16.5 Permitted Use: Customer may not:

- use the Windcave Solution, the Goods, the Software or the Documentation for any purpose other than the Permitted Use; or
- use the Software independently of the other components of the Windcave Solution unless Windcave has given prior written consent to do so.

If this Agreement is terminated, Customer's right to use the Windcave Solution, the Software and the Documentation will automatically terminate and Customer must immediately remove all copies of the Software from its system(s) and return the Windcave Solution, the Goods, the Software and the Documentation to Windcave

16.6 Reverse Engineering: Customer must not, and must not permit any other person to, reverse assemble or decompile the whole or any part of the Software.

16.7 No Third Party Use: Except as expressly provided for in this Agreement, the Customer must not provide, or otherwise make available, the Windcave Solution the Goods, the Software or the Documentation or any component thereof in any form to any person (a "Third Party") without the prior written consent of Windcave. If Windcave grants such consent, Customer must ensure that the Third Party complies with the provisions of clauses 8, 13, 15 and 16 (so far as those provisions relate to Customer) as if the Third Party were a party to this Agreement. Customer will be liable to Windcave for all acts or omissions of any Third Party in contravention of the provisions of clauses 8, 13, 15 and 16.

16.8 Installation: Customer will be responsible for, and all bear all costs associated with, the installation, operation, maintenance and support of the Goods.

16.9 Windcave Testing Prior to Launch: Prior to any permitted use of Windcave products and/or Software by Customer or any third party, Windcave shall be entitled to test all Windcave products and Software that Customer purchases, rents, or intends to use for at least seven (7) Business Days ("Pre-launch Testing"). Such Pre-launch Testing shall also entitle Windcave to at least three (3) Business Day to test transaction processing and settlement.

16.10 Labels: Customer will not remove or deface any labels affixed by Windcave to the Goods. Customer will not affix any label to the Goods.

17. Rental/Loan of Goods

Where Customer agrees to rent or borrow Goods from Windcave, the following terms and conditions apply:

- Ownership:** Legal and beneficial ownership of, and title to, the Windcave Solution, the Goods, the Software and the Documentation remains at all times with Windcave;
- Risk:** Customer will bear the risk of, and be responsible for, all loss (including theft) of or damage to, the Goods from the time that they are

first delivered to Customer until the time that they are delivered back to Windcave;

- Maintain Goods:** Customer must take reasonable steps to avoid exposure of the Goods to excessive heat, dust and moisture, liquids and electrical and physical shock;
- License Terms:** Customer must comply with all manufacturer's license terms applicable to the Goods (as supplied with the Goods or otherwise notified by Windcave to Customer from time to time);
- Theft, Seizure, Loss, Damage, Repairs:** If for any reason the Goods are stolen, seized, lost, damaged or require repairs, Customer must immediately advise Windcave of the theft, seizure, loss, damage or repairs required. Customer must pay all costs and comply with Windcave's directions in connection with replacing or recovering the Goods, repairing any damage or the replacing of any parts (fair wear and tear excepted). Customer must continue to pay the Fees while the Goods are being replaced or repaired or, in the event of theft, seizure or loss, while the Goods are missing. Windcave will not be liable for any loss or damage in relation to the unavailability of the Goods;
- No Dealing or Modifying or Security Interests:** Customer must not sell, lend, lease, transfer, modify or otherwise deal with the Goods without first obtaining Windcave's written consent. Customer must not create, or allow to be created, a security interest over the Goods;
- Inspection:** Customer must allow Windcave to inspect the Goods at any time during normal business hours, provided that Windcave first gives Customer not less than 2 Business Days notice;
- Return of Goods:** When this Agreement ends (either by completion of the Term or by way of termination), Customer will, at Customer's expense, return the Goods, in good working order and undamaged condition (fair wear and tear excepted) to Windcave's place of business. If the Customer fails to return the Goods within 14 Business Days of the end of the Agreement, Customer will pay Windcave the fair value of the Goods as at the completion of the Term;
- Repossession:** If Customer does not return the Goods when required hereunder, Windcave may (subject to compliance with applicable law) enter any premises where Windcave reasonably believes that the Goods may be located and Customer will provide all reasonable authority and assistance to enable recovery of those Goods by Windcave. Customer will be liable to Windcave for costs incurred by Windcave in recovering the Goods; and
- Further supply:** The rental of Goods by Windcave to Customer does not guarantee Customer that Windcave will supply Goods beyond the Initial Term.

18. Windcave Support Services

18.1 Support: Windcave will provide the Support Services to Customer.

18.2 Emergency Support Services and Other Services: Windcave may make available the Emergency Support Services. If Customer requires Emergency Support Services and/or services additional to the Support Services Windcave may, if it agrees to provide those services to Customer, charge Customer for those services on a time and materials basis and on such other terms and conditions as may be agreed between the parties.

18.3 Alterations to Software: Windcave may, at its sole discretion, alter, upgrade, update or change the Windcave Solution at any time during the Term of this Agreement. Customer acknowledges and agrees that, if Customer fails to promptly install all updates to any software forming part of the Windcave Solution supplied by Windcave in connection with this Agreement, Customer may be unable to process Transactions and that:

- Windcave will not be liable to Customer under this Agreement in respect of such inability; and
- Windcave will be released from any obligation to supply the Support Services during any period which Customer has failed to install any such update.

18.4 Windcave Website: Customer acknowledges and agrees that Windcave may, at its sole discretion, determine what information, data, features and functionality is made available to Customer via the Windcave Website. Customer agrees to comply with any terms that Windcave may specify in relation to Customer's use of the Windcave Website. In the event of any inconsistency between the terms and conditions of this Agreement and those on the Windcave Website, the terms and conditions of this Agreement will apply to the extent of that inconsistency. Windcave will supply user names and passwords to enable authorized users of Customer to access the Windcave Website. Customer must keep such user names and passwords secure and made known only to authorized users and will be responsible for all use of the Windcave Website through use of Customer's user names and

passwords. If Customer breaches any term of this Agreement or the terms of use of the Windcave Website, Windcave may disable Customer's user names and passwords.

- 18.5 Refunds:** Customer authorizes Windcave to process repayment transactions to its patrons, who have previously made payment using the Windcave solution, on a one-to-one matching basis ("Refund Transactions"). Customer shall be solely responsible for auditing Refund Transactions and determining that a one-to-one match is made between a transaction and its matching Refund Transaction. Customer accepts all liability for Refund Transactions. Windcave shall not be liable for any losses or damages incurred as a result of a Refund Transaction.
- 18.6 Offline Mode:** Customer authorizes Windcave to enable processing of credit cards offline in the event of an internet failure ("Offline Mode"). In addition, Customer authorizes Windcave to enact service in Offline Mode until internet service is restored for a maximum of 4 hours per event. Transactions in Offline Mode are capped at \$50 dollars maximum per transaction per card and a maximum of 500 transactions processed per device per Offline Mode event. Transactions in Offline Mode are also capped at \$1,000 per device per Offline Mode event. Customer and Windcave agree and acknowledge that Windcave is not liable for unsuccessful transactions that are a result of Offline Mode transaction processing. Customer is responsible with acquiring approval from its banking partner for operation of Offline Mode. Windcave is not liable if the terms of this Clause or the operation of Offline Mode causes Customer's account to be downgraded, shut down, disrupted, or otherwise adversely impacted in any way.
- 19. General**
- 19.1 Entire Agreement:** This Agreement including all schedules hereto records the entire arrangement between the parties relating to all matters dealt with in this Agreement and supersedes all previous arrangements, whether written, oral or both, relating to such matters.
- 19.2 Disputes:** The parties shall attempt in good faith to resolve any dispute arising out of or relating to this Agreement promptly by negotiation between executives who have authority to settle the controversy and who are at a higher level of management than the persons with direct responsibility for administration of this Agreement. Any party may give the other party written notice of any dispute not resolved in the normal course of business. Within 15 days after delivery of the notice, the receiving party shall submit to the other a written response. The notice and response shall include with reasonable particularity (a) a statement of each party's position and a summary of arguments supporting that position, and (b) the name and title of the executive who will represent that party and of any other person who will accompany the executive. Within 30 days after delivery of the notice, the executives of both parties shall meet at a mutually acceptable time and place. If the parties fail to negotiate a resolution to a dispute within a reasonable time (not exceeding 20 Business Days from formal notice of the dispute being given by one party to the other), either party may require that the dispute be submitted to mediation through JAMS, such mediation to take place in Phoenix, Arizona. A mediator shall be selected by mutual agreement or through procedures provided by JAMS. In such case:
- the mediator will not be acting as an expert or as an arbitrator;
 - the mediator will determine the procedure and timetable for the mediation; and
 - the parties will share equally the cost of the mediation.
- All offers, promises, conduct and statements, whether oral or written, made in the course of the negotiation by any of the parties, their agents, employees, experts and attorneys are confidential, privileged and inadmissible for any purpose, including impeachment, in arbitration or other proceeding involving the parties, provided that evidence that is otherwise admissible or discoverable shall not be rendered inadmissible or non-discoverable as a result of its use in the negotiation.
- Neither party may issue any legal proceedings (other than for urgent interlocutory relief) relating to any dispute, unless that party has first taken all reasonable steps to comply with the dispute resolution process above. All applicable statutes of limitation and defenses based upon the passage of time shall be tolled while the procedures specified in this clause 19.2 above are pending and for 15 calendar days thereafter. The parties will take such action, if any, required to effectuate such tolling.
- 19.3 Waiver:** No waiver of any breach, or failure to enforce any provision, of this Agreement at any time by either party shall in any way limit or waive the right of such party to subsequently enforce and compel strict compliance with the provisions of this Agreement.
- 19.4 Severance:** Any provision in this Agreement which is or becomes unenforceable, illegal or invalid for any reason shall be severed and shall not

affect the enforceability, legality, validity or application of any other provision which shall remain in full force and effect.

- 19.5 Assignment:** Windcave may assign all or any of its rights and obligations under this Agreement to any person without Customer's consent. Customer may not transfer or assign any of its liabilities or rights under this Agreement to any other person without Windcave's prior written consent (such consent not to be unreasonably withheld, provided Windcave is satisfied as to the suitability of the assignee and Customer pays to Windcave its reasonable costs incurred in connection with the assignment).
- 19.6 Amendment:** Except as expressly provided for in this Agreement, no amendment to this Agreement will be valid unless recorded in writing and signed by a duly authorized senior representative of each party.
- 19.7 Governing Law and Jurisdiction:** This Agreement is governed by the laws of Arizona. Subject to the terms of clause 19.2, the parties submit to the jurisdiction of the courts of the State of Arizona in respect of all matters relating to this Agreement.
- 19.8 Remedies:** The rights, powers and remedies provided in this Agreement are not exclusive of any rights, powers or remedies provided by law.
- 19.9 Subcontracting:** Windcave may appoint subcontractors to perform any of its obligations under this Agreement.
- 19.10 Counterparts and Copies:** This Agreement may be signed in any number of counterpart copies which, read together, will constitute one and the same document. Any facsimile copy of this agreement or copy of this agreement sent via email in PDF format (including any facsimile copy or copy sent via email in PDF format, of any document evidencing either party's signature of this agreement) may be relied upon by the other party as if it were an original copy. This Agreement may be entered into on the basis of an exchange of such facsimile or PDF copies.
- 19.11 Notices:** Any notice or other communication to be given under this Agreement must be in writing and must be served by one of the following means and in respect of each is deemed to have been served as described:
- By personal delivery – when received by the party.
 - By post by registered or ordinary mail – on the second working day following the date of posting in the United States mail to the addressee's registered office.
 - By email – when acknowledged by the party orally or by return email or otherwise in writing.
- The addresses for the parties for Notices shall be as set out on Page 1 of this Agreement or such other address as either party specifies by notice in writing to the other given in accordance with this clause 19.11.
- 19.12 Conflicts:** In the event of any conflict or inconsistency between this Agreement and the terms of a purchase order made by Customer to Windcave, this Agreement shall govern and control.



Board of Public Works Staff Report

Project/Event: 2024 Service Agreement with H&K Maintenance, LLC for Mowing, Vegetation Removal, and Turf Maintenance Services

Petitioner/Representative: Public Works Facilities Division

Staff Representative: J.D. Boruff, Operations and Facilities Director

Meeting Date: May 6, 2024

This contract is for mowing, vegetation removal, and turf maintenance, and snow removal services at City facilities maintained by the Public Works Facilities Division.

Compensation not to exceed \$15,000.00.

Respectfully submitted,

A handwritten signature in black ink that reads "JD Boruff". The signature is written in a cursive, slightly stylized font.

J.D. Boruff
Operations and Facilities Director
Public Works Department

City of Bloomington Contract and Purchase Justification Form

Vendor: H&K Maintenance, LLC

Contract Amount: \$15,000

This form should be completed and attached to the contract documents and forwarded to the Legal Department Attorney assigned to your Department. Contracts will not be approved by the Controller if a completed form is not included with the contract documents.

PURCHASE INFORMATION

1. Check the box beside the procurement method used to initiate this procurement: (Attach a quote or bid tabulation if applicable)

<input type="checkbox"/> Request for Quote (RFQ)	<input type="checkbox"/> Request for Proposal (RFP)	<input type="checkbox"/> Sole Source	<input checked="" type="checkbox"/> Not Applicable (NA)
<input type="checkbox"/> Invitation to Bid (ITB)	<input type="checkbox"/> Request for Qualifications (RFQu)	<input type="checkbox"/> Emergency Purchase	

2. List the results of procurement process. Give further explanation where requested.

	Yes	No	Was the lowest cost selected? (If no, please state below why it was not.)
# of Submittals: 1			<input type="checkbox"/> Yes <input checked="" type="checkbox"/> No
Met city requirements?	<input checked="" type="checkbox"/>	<input type="checkbox"/>	Quotes were not solicited. We used the standard Service Agreement process.
Met item or need requirements?	<input checked="" type="checkbox"/>	<input type="checkbox"/>	
Was an evaluation team used?	<input type="checkbox"/>	<input checked="" type="checkbox"/>	
Was scoring grid used?	<input type="checkbox"/>	<input checked="" type="checkbox"/>	
Were vendor presentations requested?	<input type="checkbox"/>	<input checked="" type="checkbox"/>	

3. State why this vendor was selected to receive the award and contract:

This is our selected vendor. We used standard Service Agreement process.

J.D. Boruff

Director of Facilities

Public Works

Print/Type Name

Print/Type Title

Department

**AGREEMENT BETWEEN CITY OF BLOOMINGTON
PUBLIC WORKS DEPARTMENT AND
H&K MAINTENANCE, LLC**

This Agreement, entered into on this 6th day of May, 2024, by and between the City of Bloomington Department of Public Works (the "Department"), and H&K Maintenance, LLC ("Contractor").

Article 1. Scope of Services After receiving a **Notice to Proceed**, Contractor shall perform repair and maintenance services of the following types: Mowing, vegetation removal, turf treatments and fertilizing. These services will be performed at City facilities ("Services") for a set price of Fifty Dollars (\$50.00) per person, per hour. This rate shall include any trip charges and/or fuel charges. Costs for materials, such as fertilizer, mulch, or chemical treatments shall be paid by the Department. Contractor shall diligently provide the Services under this Agreement and shall complete the Services described in this Agreement in a timely manner consistent with the Standard of Care identified in Article 2. Contractor shall complete the Services required under this Agreement on or before December 31, 2024, unless the parties mutually agree to a later completion date. Completion shall mean completion of all work related to the Services. In the performance of Contractor's work, Contractor agrees to maintain such coordination with the Department as may be requested and desirable, including primary coordination with J.D. Boruff, Operations and Facilities Director, Public Works Department. Contractor agrees that any information or documents, including digital GIS information, supplied by the Department pursuant to Article 3, below, shall be used by Contractor for this project only, and shall not be reused or reassigned for any other purpose without the written permission of the Department.

Article 2. Standard of Care Contractor shall be responsible for completion of the Services in a manner consistent with that degree of care and skill ordinarily exercised by members of the same profession currently practicing under similar circumstances ("Standard of Care"). The Department shall be the sole judge of the adequacy of Contractor's work in meeting the Standard of Care; however, the Department shall not unreasonably withhold its approval as to the adequacy of Contractor's performance. Upon notice to Contractor and by mutual agreement between the parties, Contractor will, without additional compensation, correct or replace any and all Services not meeting the Standard of Care.

Article 3. Responsibilities of the Department The Department shall provide all necessary information regarding requirements for the Services. The Department shall furnish such information as necessary for the orderly progress of the work, and Contractor shall be entitled to rely upon the accuracy and completeness of such information. The Department's Project Manager shall act on its behalf with respect to this Agreement.

Article 4. Compensation The Department shall pay Contractor for all fees and expenses in an amount not to exceed Fifteen Thousand Dollars (\$15,000.00). Contractor shall submit an invoice to the Department upon the completion of the Services described in Article 1. Invoices shall be sent via email to public.works@bloomington.in.gov or via first class mail postage prepaid to: J.D. Boruff, City of Bloomington Public Works, 401 N. Morton, Suite 120, Bloomington, Indiana 47404. Invoices may be sent via first class mail postage prepaid or via email. Payment will be remitted to Contractor within forty-five (45) days of receipt of invoice. Additional services not set forth in Article 1, or changes in the Services must be authorized in writing by the Department or its designated project coordinator prior to such work being performed, or expenses incurred. The Department shall not make payment for any unauthorized work or expenses.

Article 5. Appropriation of Funds Notwithstanding any other provision of this Agreement, if funds for the continued fulfillment of this Agreement by the Department are at any time not

forthcoming or are insufficient, through failure of any entity, including the Department itself, to appropriate funds or otherwise, then the Department shall have the right to terminate this Agreement without penalty.

Article 6. Schedule Contractor shall perform the Services according to the following schedule: Services will be on as needed basis upon request of the Department. The time limits established by this schedule shall not be exceeded, except for reasonable cause as mutually agreed to by all parties.

Article 7. Termination In the event of a party's substantial failure to perform in accordance with the terms of this Agreement, the other party shall have the right to terminate the Agreement upon written notice. The non-performing party shall have fourteen (14) calendar days from the receipt of the termination notice to cure or to submit a plan for cure acceptable to the other party. Additionally, the Department may terminate or suspend performance of this Agreement at the Department's prerogative at any time upon written notice to Contractor. Contractor shall terminate or suspend performance of the Services on a schedule acceptable to the Department and the Department shall pay the Contractor for all the Services performed up to the date that written notice is received, plus reasonable termination or suspension expenses. Upon restart, an equitable adjustment shall be made to Contractor's compensation and the schedule of services. Upon termination or suspension of this Agreement, all finished or unfinished reports, drawings, collections of data and other documents generated by Contractor in connection with this Agreement shall become the property of the Department, as set forth in Article 9 herein.

Article 8. Identity of the Contractor Contractor acknowledges that one of the primary reasons for its selection by the Department to perform the Services is the qualifications and experience of Contractor. Contractor thus agrees that the Services to be performed pursuant to this Agreement shall be performed by Contractor. Contractor shall not subcontract any part of the Services without the prior written permission of the Department. The Department reserves the right to reject any of the Contractor's personnel or proposed outside professional sub-Contractors, and the Department reserves the right to request that acceptable replacement personnel be assigned to the project.

Article 9. Ownership of Documents and Intellectual Property All documents, drawings and specifications, including digital format files, prepared by Contractor and furnished to the Department as part of the Services shall become the property of the Department. Contractor shall retain its ownership rights in its design, drawing details, specifications, databases, computer software and other proprietary property. Intellectual property developed, utilized or modified in the performance of the Services shall remain the property of Contractor.

Article 10. Independent Contractor Status During the entire term of this Agreement, Contractor shall be an independent contractor, and in no event shall any of its personnel, agents or sub-contractors be construed to be, or represent themselves to be, employees of the Department. Contractor shall be solely responsible for the payment and reporting of all employee and employer taxes, including social security, unemployment, and any other federal, state, or local taxes required to be withheld from employees or payable on behalf of employees.

Article 11. Indemnification Contractor shall indemnify and hold harmless the City of Bloomington, the Department, and the officers, agents and employees of the City and the Department from any and all claims, demands, damages, costs, expenses or other liability arising out of the Agreement or occasioned by the reckless or negligent performance of any provision thereof, including, but not limited to, any reckless or negligent act or failure to act or any misconduct on the part of the Contractor or its agents or employees, or any independent contractors directly responsible to it (collectively "Claims").

Article 12. Insurance During the performance of any and all Services under this Agreement, Contractor shall maintain the following insurance in full force and effect: a) General Liability Insurance, with a minimum combined single limit of \$1,000,000 for each occurrence and \$2,000,000 in the aggregate; b) Automobile Liability Insurance, with a minimum combined single limit of \$1,000,000 for each person and \$1,000,000 for each accident; c) Workers' Compensation Insurance in accordance with the statutory requirements of Title 22 of the Indiana Code; and d) Professional Liability Insurance ("Errors and Omissions Insurance") with a minimum limit of \$1,000,000 annual aggregate. All insurance policies shall be issued by an insurance company authorized to issue such insurance in the State of Indiana. The City of Bloomington, the Department, and the officers, employees and agents of each shall be named as insureds under the General Liability, Automobile, and Worker's Compensation policies, and such policies shall stipulate that the insurance will operate as primary insurance and that no other insurance of the City's will be called upon to contribute to a loss hereunder. Contractor shall provide evidence of each insurance policy to the Department prior to the commencement of work under this Agreement.

Article 13. Conflict of Interest Contractor declares that it has no present interest, nor shall it acquire any interest, direct or indirect, which would conflict with the performance of Services under this Agreement. Contractor agrees that no person having any such interest shall be employed in the performance of this Agreement.

Article 14. Waiver No failure of either party to enforce a term of this Agreement against the other shall be construed as a waiver of that term, nor shall it in any way affect the party's right to enforce that term. No waiver by any party of any term of this Agreement shall be considered to be a waiver of any other term or breach thereof.

Article 15. Severability The invalidity, illegality or unenforceability of any provision of this Agreement or the occurrence of any event rendering any portion or provision of this Agreement void shall in no way affect the validity or enforceability of any other portion or provision of this Agreement. Any void provision shall be deemed severed from this Agreement, and the balance of the Agreement shall be construed and enforced as if it did not contain the particular provision to be held void. The parties further agree to amend this Agreement to replace any stricken provision with a valid provision that comes as close as possible to the intent of the stricken provision. The provisions of this Article shall not prevent this entire Agreement from being void should a provision which is of the essence of this Agreement be determined void.

Article 16. Assignment Neither the Department nor the Contractor shall assign any rights or duties under this Agreement without the prior written consent of the other party. Unless otherwise stated in the written consent to an assignment, no assignment will release or discharge the assignor from any obligation under this Agreement.

Article 17. Third Party Rights Nothing in this Agreement shall be construed to give any rights or benefits to anyone other than the parties.

Article 18. Governing Law and Venue This Agreement shall be governed by the laws of the State of Indiana. Venue of any disputes arising under this Agreement shall be in the Monroe Circuit Court, Monroe County, Indiana.

Article 19. Non-Discrimination Contractor shall comply with City of Bloomington Ordinance 2.21.020 and all other federal, state and local laws and regulations governing non-discrimination in all regards, including, but not limited to, employment. Contractor understands that the City of Bloomington prohibits its employees from engaging in harassment or discrimination of any kind,

including harassing or discriminating against independent contractors doing work for the City. If the Contractor believes that a City employee engaged in such conduct towards Contractor and/or any of its employees, Contractor or its employees may file a complaint with the City department head in charge of the Contractor's work and/or with the City human resources department or the Bloomington Human Rights Commission. The City takes all complaints of harassment and discrimination seriously and will take appropriate disciplinary action if it finds that any City employee engaged in such prohibited conduct.

Article 20. Compliance with Laws In performing the Services under this Agreement, Contractor shall comply with any and all applicable federal, state and local statutes, ordinances, plans and regulations, including any and all regulations for protection of the environment. Where such statutes, ordinances, plans or regulations of any public authority having any jurisdiction over the project are in conflict, Contractor shall proceed using its best judgment only after attempting to resolve any such conflict between such governmental agencies, and shall notify the Department in a timely manner of the conflict, attempts of resolution, and planned course of action.

Article 21. E-Verify Contractor is required to enroll in and verify the work eligibility status of all newly-hired employees through the E-Verify program. (This is not required if the E-Verify program no longer exists). Contractor shall sign an affidavit, attached as Exhibit A, affirming that Contractor does not knowingly employ an unauthorized alien. Contractor shall require any subcontractors performing work under this contract to certify to the Contractor that, at the time of certification, the subcontractor does not knowingly employ or contract with an unauthorized alien and the subcontractor has enrolled in and is participating in the E-Verify program. Contractor shall maintain on file all subcontractors' certifications throughout the term of the contract with the City.

Article 22. Notices Any notice required by this Agreement shall be made in writing to the individuals/addresses specified below:

Department: City of Bloomington Public Works, Attn: J.D. Boruff, 401 N. Morton, Suite 120, Bloomington, Indiana 47404.

Contractor: H&K Maintenance, LLC, 1590 E. Hupp Rd. Bloomington, IN. 47401.

Nothing contained in this Article shall be construed to restrict the transmission of routine communications between representatives of the Department and Contractor.

Article 23. Integration and Modification This Agreement, including all Exhibits incorporated by reference, represents the entire and integrated agreement between the Department and the Contractor. It supersedes all prior and contemporaneous communications, representations and agreements, whether oral or written, relating to the subject matter of this Agreement. This Agreement may be modified only by a written amendment signed by both parties hereto.

Article 24. Non-Collusion Contractor is required to certify that it has not, nor has any other member, representative, or agent of Contractor, entered into any combination, collusion, or agreement with any person relative to the price to be offered by any person nor prevented any person from making an offer nor induced anyone to refrain from making an offer and that this offer is made without reference to any other offer. Contractor shall sign an affidavit, attached hereto as Exhibit B, affirming that Contractor has not engaged in any collusive conduct. Exhibit B is attached hereto and incorporated by reference as though fully set forth.

Article 25: Renewal This Agreement may be renewed for three additional one-year terms so long as none of the terms and conditions herein are modified in any way. Renewal shall only occur upon advanced written notice by the City to the Contractor that the City wishes to renew the Agreement at least thirty (30) days, but not more than sixty (60) days, prior to the end of the current term.

CITY OF BLOOMINGTON

Margie Rice, Corporation Counsel

H&K Maintenance, LLC

Henry Bryant, Owner

CITY OF BLOOMINGTON PUBLIC WORKS

Adam Wason, Director

Kyla Cox-Deckard, President, Board of Public Works

EXHIBIT B

STATE OF INDIANA)
) SS:
COUNTY OF _____)

NON-COLLUSION AFFIDAVIT

The undersigned offeror or agent, being duly sworn on oath, says that he has not, nor has any other member, representative, or agent of the firm, company, corporation or partnership represented by him, entered into any combination, collusion or agreement with any person relative to the price to be offered by any person nor to prevent any person from making an offer nor to induce anyone to refrain from making an offer and that this offer is made without reference to any other offer.

OATH AND AFFIRMATION

I affirm under the penalties of perjury that the foregoing facts and information are true and correct to the best of my knowledge and belief.

Dated this _____ day of _____, 20____.

H&K Maintenance, LLC

By: _____

STATE OF INDIANA)
) SS:
COUNTY OF _____)

Before me, a Notary Public in and for said County and State, personally appeared _____ and acknowledged the execution of the foregoing this ____ day of _____, 20____.

Notary Public Printed Name

Notary Public's Signature

My Commission Expires: _____

County of Residence: _____

My Commission #: _____



Board of Public Works Claim Register

Invoice Date Range 04/27/24 - 05/10/24

Vendor	Invoice Description	Contract #	Payment Date	Invoice Amount
Fund 101 - General Fund (S0101)				
Department 01 - Animal Shelter				
Program 010000 - Main				
Account 43430 - Animal Adoption Fees				
Jillian Grzesiak	01-refund adoption fee-canine--4/15/24		05/10/2024	100.00
	Account 43430 - Animal Adoption Fees Totals	Invoice 1		<u>\$100.00</u>
		Transactions		
Account 43442 - Equipment Deposits				
Linda Zambanini	01-refund trap deposit-4/12/24		05/10/2024	40.00
	Account 43442 - Equipment Deposits Totals	Invoice 1		<u>\$40.00</u>
		Transactions		
Account 46080 - Animal Control Violations				
Christopher Van Lieu	01-Provided proof of pay, violation changed from \$100 to \$20		05/10/2024	80.00
	Account 46080 - Animal Control Violations Totals	Invoice 1		<u>\$80.00</u>
		Transactions		
Account 52210 - Institutional Supplies				
4586 - Hill's Pet Nutrition Sales, INC	01-Dog, puppy, cat & kitten Food	BC 2024-026	05/10/2024	160.94
4586 - Hill's Pet Nutrition Sales, INC	01-Prescription Vet Pet Food	BC 2024-026	05/10/2024	172.46
4586 - Hill's Pet Nutrition Sales, INC	01-Prescription Vet Pet Food	BC 2024-026	05/10/2024	201.09
4586 - Hill's Pet Nutrition Sales, INC	01-Dog, kitten, cat food	BC 2024-026	05/10/2024	191.68
4574 - John Deere Financial f.s.b. (Rural King)	01-litter-50 40lb bags pellet bedding		05/10/2024	249.50
4633 - Midwest Veterinary Supply, INC	01-Solution for compounding meds		05/10/2024	18.06
4633 - Midwest Veterinary Supply, INC	01-vinyl exam gloves (L)		05/10/2024	53.95
4633 - Midwest Veterinary Supply, INC	01-vinyl exam gloves (L)		05/10/2024	53.95
4633 - Midwest Veterinary Supply, INC	01-Pet Corrector		05/10/2024	60.53



Board of Public Works Claim Register

Invoice Date Range 04/27/24 - 05/10/24

4633 - Midwest Veterinary Supply, INC	01-Antibiotics, antihistamines, Fluoxetine	05/10/2024	103.17
4633 - Midwest Veterinary Supply, INC	01-Antibiotics, Flavor Syrup	05/10/2024	121.66
4633 - Midwest Veterinary Supply, INC	01-vinyl exam gloves (L), syringes	05/10/2024	174.20
4633 - Midwest Veterinary Supply, INC	01-Fluids, syringes, antiparasitics, supportive corrective meds	05/10/2024	261.41
4633 - Midwest Veterinary Supply, INC	01-Partnership Program rebate	05/10/2024	(324.87)
4633 - Midwest Veterinary Supply, INC	01-Needles, FeLV diagnostic kits, antibiotics	05/10/2024	763.26
4633 - Midwest Veterinary Supply, INC	01-Sanitizer-Rescue Concentrate (55 gal)	05/10/2024	1,678.92
Account 52210 - Institutional Supplies Totals		Invoice 16 Transactions	\$3,939.91
Account 52310 - Building Materials and Supplies			
8658 - Kleindorfer's Hardware LLC	01-Hook for equipment repair	05/10/2024	.69
Account 52310 - Building Materials and Supplies Totals		Invoice 1 Transactions	\$0.69
Account 52340 - Other Repairs and Maintenance			
313 - Fastenal Company	01-Disinfecting wipes bucket	05/10/2024	4.15
313 - Fastenal Company	01-Hand soap	05/10/2024	36.21
313 - Fastenal Company	01-Trash Liners	05/10/2024	136.36
313 - Fastenal Company	01-Scrub brushes	05/10/2024	161.25
313 - Fastenal Company	01-Laundry detergent	05/10/2024	193.96
Account 52340 - Other Repairs and Maintenance Totals		Invoice 5 Transactions	\$531.93
Account 52420 - Other Supplies			
4549 - Kroger Limited Partnership I	01-Staff Lunch Eclipse-veggie, meat and fruit trays	05/10/2024	42.96
Account 52420 - Other Supplies Totals		Invoice 1 Transactions	\$42.96
Account 53130 - Medical			
6529 - BloomingPaws, LLC	01-Emergency visit and diagnostics-Barry B Benson	05/10/2024	594.00



Board of Public Works Claim Register

Invoice Date Range 04/27/24 - 05/10/24

3376 - Bloomington Pets Alive, INC	01-Spay/Neuter Surgeries-4/1-4/15/24		05/10/2024	4,007.00
	Account 53130 - Medical Totals		Invoice 2	<u>\$4,601.00</u>
			Transactions	
Account 53210 - Telephone				
13969 - AT&T Mobility II, LLC	06-cell phone chgs 03/12-04/11/24-Inv. 287297421132X04192024		05/01/2024	40.94
13969 - AT&T Mobility II, LLC	06-cell phone chgs 03/12-04/11/24-Inv. 287289748780X04192024		05/01/2024	250.18
	Account 53210 - Telephone Totals		Invoice 2	<u>\$291.12</u>
			Transactions	
Account 53540 - Natural Gas				
222 - Indiana Gas Co. INC (CenterPoint Energy) (Vectren)	01-ACC-gas bill 03/04/24-04/02/24		04/29/2024	518.18
	Account 53540 - Natural Gas Totals		Invoice 1	<u>\$518.18</u>
			Transactions	
Account 53610 - Building Repairs				
1537 - Indiana Door & Hardware Specialties, INC	01 - Yale closer and service call for cat room	BC 2023-076	05/10/2024	250.00
	Account 53610 - Building Repairs Totals		Invoice 1	<u>\$250.00</u>
			Transactions	
	Program 010000 - Main Totals		Invoice 32	<u>\$10,395.79</u>
			Transactions	
Program 010001 - Donations Over \$5K				
Account 53130 - Medical				
6529 - BloomingPaws, LLC	01-Heartworm Treatment-Roscoe		05/10/2024	90.68
6529 - BloomingPaws, LLC	01-Exam & wound care-Wilford		05/10/2024	132.13
6529 - BloomingPaws, LLC	01- Heartworm Treatments-Tennessee		05/10/2024	160.33
6529 - BloomingPaws, LLC	01- Heartworm Treatments-Lura		05/10/2024	178.70
6529 - BloomingPaws, LLC	01-Exam & x-rays-Tommy		05/10/2024	192.00
6529 - BloomingPaws, LLC	01-Exam, X-rays, Diagnostics-Jupiter		05/10/2024	237.78
6529 - BloomingPaws, LLC	01-Heartworm Treatment-Sherlock Bones & Ross		05/10/2024	296.48
54639 - Shake Veterinary Services, INC (Town & Country Vet	01-X-rays & exams-3/18-4/16/24		05/10/2024	246.55



Board of Public Works Claim Register

Invoice Date Range 04/27/24 - 05/10/24

Account 53130 - Medical Totals	Invoice 8	\$1,534.65
Program 010001 - Donations Over \$5K Totals	Transactions Invoice 8	\$1,534.65
Department 01 - Animal Shelter Totals	Transactions Invoice 40	\$11,930.44
	Transactions	
Department 02 - Public Works		
Program 020000 - Main		
Account 52110 - Office Supplies		
8541 - Amazon.com Sales, INC (Amazon.com Services LLC)	02-PW Return Document Display Holders for Conference Rooms	05/10/2024 (17.99)
	Account 52110 - Office Supplies Totals	Invoice 1 (\$17.99)
	Transactions	
Account 52420 - Other Supplies		
5086 - Frame Station, INC (Framemakers)	02-Framing for DPW Admin Organization Chart	05/10/2024 139.09
	Account 52420 - Other Supplies Totals	Invoice 1 \$139.09
	Transactions	
Account 53160 - Instruction		
7450 - International City/County Management Association	02-PW_Membership dues- Michael Large	05/10/2024 200.00
	Account 53160 - Instruction Totals	Invoice 1 \$200.00
	Transactions	
Account 53210 - Telephone		
13969 - AT&T Mobility II, LLC	06-cell phone chgs 03/12-04/11/24-Inv. 287289748780X04192024	05/01/2024 130.25
1079 - AT&T	02-Radio circuits-phone charges 02/29-03/28/24	05/01/2024 180.23
	Account 53210 - Telephone Totals	Invoice 2 \$310.48
	Program 020000 - Main Totals	Transactions Invoice 5 \$631.58
	Department 02 - Public Works Totals	Transactions Invoice 5 \$631.58
	Transactions	
Department 03 - City Clerk		
Program 030000 - Main		
Account 52420 - Other Supplies		



Board of Public Works Claim Register

Invoice Date Range 04/27/24 - 05/10/24

6222 - Apple, INC	03-Apple pencil for clerk staff apple devices	05/10/2024	119.00
	Account 52420 - Other Supplies Totals	Invoice 1	<u>\$119.00</u>
Account 53210 - Telephone		Transactions	
13969 - AT&T Mobility II, LLC	06-cell phone chgs 03/12-04/11/24-Inv. 287297421132X04192024	05/01/2024	163.76
	Account 53210 - Telephone Totals	Invoice 1	<u>\$163.76</u>
	Program 030000 - Main Totals	Transactions	
	Department 03 - City Clerk Totals	Invoice 2	<u>\$282.76</u>
		Transactions	
		Invoice 2	<u>\$282.76</u>
		Transactions	
Department 04 - Economic & Sustainable Dev			
Program 040000 - Main			
Account 53210 - Telephone			
13969 - AT&T Mobility II, LLC	06-cell phone chgs 03/12-04/11/24-Inv. 287297421132X04192024	05/01/2024	81.88
	Account 53210 - Telephone Totals	Invoice 1	<u>\$81.88</u>
		Transactions	
Account 53310 - Printing			
8497 - Jonathon Keown (Hideout Press)	04-Printing of 300 Eclipse Project Postcards	05/10/2024	290.08
	Account 53310 - Printing Totals	Invoice 1	<u>\$290.08</u>
		Transactions	
Account 53910 - Dues and Subscriptions			
8845 - ClimateNav, INC	04-ClimateNav-Second Half Annual Fee for FY23-24	05/10/2024	30,000.00
	Account 53910 - Dues and Subscriptions Totals	Invoice 1	<u>\$30,000.00</u>
		Transactions	
Account 53970 - Mayor's Promotion of Business			
6714 - Dimension Mill, INC	04-AlgoRhythms Music Tech Summit Reception Sponsorship	05/10/2024	500.00
9271 - Sally Harless	04-Art for COB Postcard Project	05/10/2024	500.00
4549 - Kroger Limited Partnership I	04-Snacks for Bloomington Art Commission Grant Review Sessions	05/10/2024	15.49
	Account 53970 - Mayor's Promotion of Business Totals	Invoice 3	<u>\$1,015.49</u>
		Transactions	



Board of Public Works Claim Register

Invoice Date Range 04/27/24 - 05/10/24

Program 040000 - Main Totals		Invoice 6	\$31,387.45
Program 04TECH - Trades Tech Center		Transactions	
Account 53990 - Other Services and Charges			
3909 - Applied Engineering Services, INC	04-Trades District Tech Center services thru 09/15/23	05/10/2024	2,100.00
18844 - First Financial Bank, N.A.	04-Harrell-Fish (HFI) Escrow-Tech Ctr-App 6	05/10/2024	3,647.70
321 - Harrell Fish, INC (HFI)	04-Mechanical Contractor Work-Tech Ctr-Proj 004307-App 6	05/10/2024	69,306.30
Account 53990 - Other Services and Charges Totals		Invoice 3	\$75,054.00
Program 04TECH - Trades Tech Center Totals		Transactions	
Department 04 - Economic & Sustainable Dev Totals		Invoice 3	\$75,054.00
		Transactions	
		Invoice 9	\$106,441.45
		Transactions	
Department 05 - Common Council			
Program 050000 - Main			
Account 53210 - Telephone			
13969 - AT&T Mobility II, LLC	06-cell phone chgs 03/12-04/11/24-Inv. 287297421132X04192024	05/01/2024	40.94
Account 53210 - Telephone Totals		Invoice 1	\$40.94
Program 050000 - Main Totals		Transactions	
Department 05 - Common Council Totals		Invoice 1	\$40.94
		Transactions	
		Invoice 1	\$40.94
		Transactions	
Department 06 - Controller's Office			
Program 060000 - Main			
Account 52110 - Office Supplies			
6530 - Office Depot, INC	06-Storage boxes, air duster, pencil refills, batteries, tape	05/10/2024	103.24
6530 - Office Depot, INC	06-5 Subject 8.5/11.5 Notebook (200 pgs)	05/10/2024	5.19
Account 52110 - Office Supplies Totals		Invoice 2	\$108.43
Account 52420 - Other Supplies		Transactions	



Board of Public Works Claim Register

Invoice Date Range 04/27/24 - 05/10/24

8541 - Amazon.com Sales, INC (Amazon.com Services LLC)	06-Wireless Keyboard and Mouse Combo (Dean, Landlev. McClellan)	05/10/2024	239.97
371 - Pitney Bowes, INC	06- Ink and sealing solution for Postage Machine	05/10/2024	426.28
	Account 52420 - Other Supplies Totals	Invoice 2	<u>\$666.25</u>
	Program 060000 - Main Totals	Transactions Invoice 4	<u>\$774.68</u>
	Department 06 - Controller's Office Totals	Transactions Invoice 4	<u>\$774.68</u>
		Transactions	
Department 07 - Engineering			
Program 070000 - Main			
Account 52420 - Other Supplies			
6222 - Apple, INC	07-iPads & Apple Care+ (4 each)	05/10/2024	2,552.00
	Account 52420 - Other Supplies Totals	Invoice 1	<u>\$2,552.00</u>
		Transactions	
Account 52430 - Uniforms and Tools			
798 - Winters Associates Promotional Products, INC	07-Quarter Zip Jacket for Engineering Employee	05/10/2024	67.00
	Account 52430 - Uniforms and Tools Totals	Invoice 1	<u>\$67.00</u>
		Transactions	
Account 53210 - Telephone			
13969 - AT&T Mobility II, LLC	06-cell phone chgs 03/12-04/11/24-Inv. 287297421132X04192024	05/01/2024	579.24
	Account 53210 - Telephone Totals	Invoice 1	<u>\$579.24</u>
		Transactions	
Account 53230 - Travel			
9035 - Kyle Baugh	07-reimb-PU Road School Training -Lafayette, IN-3/12-3/13/24	05/10/2024	10.00
9248 - Zachariah Rogers	07-reimb-PU Road School Training -Lafayette, IN-3/12-3/13/24	05/10/2024	10.00
	Account 53230 - Travel Totals	Invoice 2	<u>\$20.00</u>
	Program 070000 - Main Totals	Transactions Invoice 5	<u>\$3,218.24</u>
	Department 07 - Engineering Totals	Transactions Invoice 5	<u>\$3,218.24</u>
		Transactions	
Department 09 - CFRD			



Board of Public Works Claim Register

Invoice Date Range 04/27/24 - 05/10/24

Program **090000 - Main**

Account **49991 - Prior Year Replacement Checks**

4440 - Points of Light Foundation	09-Affiliate Membership Annual Dues 2023-2024-Resent Check	05/10/2024	125.00
	Account 49991 - Prior Year Replacement Checks Totals	Invoice 1	<u>125.00</u>
		Transactions	

Account **52420 - Other Supplies**

8541 - Amazon.com Sales, INC (Amazon.com Services LLC)	09-Fluorescent Light Covers-4 pack	05/10/2024	25.99
	Account 52420 - Other Supplies Totals	Invoice 1	<u>25.99</u>
		Transactions	

Account **53210 - Telephone**

13969 - AT&T Mobility II, LLC	06-cell phone chgs 03/12-04/11/24-Inv. 287297421132X04192024	05/01/2024	163.76
	Account 53210 - Telephone Totals	Invoice 1	<u>163.76</u>
		Transactions	
	Program 090000 - Main Totals	Invoice 3	<u>314.75</u>
		Transactions	
	Department 09 - CFRD Totals	Invoice 3	<u>314.75</u>
		Transactions	

Department **10 - Legal**

Program **100000 - Main**

Account **53990 - Other Services and Charges**

205 - City Of Bloomington	10-PC Reimb-Mo Co Rec-Waiver of Annexation Fee-1398 E Rhorer Rd	05/10/2024	25.00
	Account 53990 - Other Services and Charges Totals	Invoice 1	<u>25.00</u>
		Transactions	
	Program 100000 - Main Totals	Invoice 1	<u>25.00</u>
		Transactions	
	Department 10 - Legal Totals	Invoice 1	<u>25.00</u>
		Transactions	

Department **11 - Mayor's Office**

Program **110000 - Main**

Account **43380 - Other Services**

4123 - Central Indiana Interpreting Service	11 - interpreting service-State of the City Address-4/9/24	05/10/2024	321.64
---	--	------------	--------



Board of Public Works Claim Register

Invoice Date Range 04/27/24 - 05/10/24

7149 - Namify, LLC	11 - name tags per requests (9)	05/10/2024	116.75
7149 - Namify, LLC	11 - name tags per requests (3)	05/10/2024	37.75
7149 - Namify, LLC	11 - name tags per requests (2)	05/10/2024	27.50
7149 - Namify, LLC	11 - name tags per requests (2)	05/10/2024	26.50
7149 - Namify, LLC	11 - name tags per requests (2)	05/10/2024	38.50
7149 - Namify, LLC	11 - name tags per requests (3)	05/10/2024	37.75
7149 - Namify, LLC	11 - name tags per requests (2)	05/10/2024	38.50
7240 - Troy T Thomas	11-State of the City Address-singing National Anthem-4/9/24	05/10/2024	175.00
Account 43380 - Other Services Totals		Invoice 9 Transactions	<u>\$819.89</u>
Account 47080 - Other Reimbursements			
8363 - Rose Smith	11-Sams Club-State of City Address food & beverage-4/9/24	05/10/2024	92.88
Account 47080 - Other Reimbursements Totals		Invoice 1 Transactions	<u>\$92.88</u>
Account 52110 - Office Supplies			
8541 - Amazon.com Sales, INC (Amazon.com Services LLC)	11-office supplies -label maker, stamp, in boxes	05/10/2024	66.68
6530 - Office Depot, INC	11 - file folders for proclamations	05/10/2024	95.95
6530 - Office Depot, INC	11 - file folders for proclamations and gold seals	05/10/2024	13.17
Account 52110 - Office Supplies Totals		Invoice 3 Transactions	<u>\$175.80</u>
Account 52420 - Other Supplies			
423 - City Glass of Bloomington, INC	11 - glass top for coffee service table	05/10/2024	41.89
Account 52420 - Other Supplies Totals		Invoice 1 Transactions	<u>\$41.89</u>
Account 53160 - Instruction			
9158 - Krista Padgett	11-professional coaching for J. Madrigal March-April 2024-3 sess	05/10/2024	1,200.00
Account 53160 - Instruction Totals		Invoice 1 Transactions	<u>\$1,200.00</u>



Board of Public Works Claim Register

Invoice Date Range 04/27/24 - 05/10/24

Account 53170 - Mgt. Fee, Consultants, and Workshops

9138 - Jeffery R Harris	11-communications services 03/01/24-03/31/24	05/10/2024	3,600.00
	Account 53170 - Mgt. Fee, Consultants, and Workshops Totals	Invoice 1	<u>\$3,600.00</u>
		Transactions	

Account 53310 - Printing

129 - FedEx Print Service, INC (Printing Only)	11-printing programs-State of City- FedEx Acct #0547243307	05/10/2024	400.73
	Account 53310 - Printing Totals	Invoice 1	<u>\$400.73</u>
		Transactions	

Account 53910 - Dues and Subscriptions

6042 - International Town & Gown Association	11 - renewal of ITGA membership-5/2/24-5/2/25	05/10/2024	650.00
	Account 53910 - Dues and Subscriptions Totals	Invoice 1	<u>\$650.00</u>
		Transactions	

Account 53990 - Other Services and Charges

9276 - Alyson E Baer	11-Krogers-State of the City snack/water reimb-4/9/24	05/10/2024	84.17
1138 - BCT Management, INC	11-State of the City Address-rental/misc-4/9/24	05/10/2024	843.00
9277 - Rebecca A Gavin (Gavin Design)	11 - decorator fee for Mayor's Office design-1/16-2/8/24	05/10/2024	1,060.50
	Account 53990 - Other Services and Charges Totals	Invoice 3	<u>\$1,987.67</u>
		Transactions	
	Program 110000 - Main Totals	Invoice 21	<u>\$8,968.86</u>
		Transactions	
	Department 11 - Mayor's Office Totals	Invoice 21	<u>\$8,968.86</u>
		Transactions	

Department 12 - Human Resources

Program 120000 - Main

Account 53210 - Telephone

13969 - AT&T Mobility II, LLC	06-cell phone chgs 03/12-04/11/24-Inv. 287297421132X04192024	05/01/2024	47.02
	Account 53210 - Telephone Totals	Invoice 1	<u>\$47.02</u>
		Transactions	

Account 53990 - Other Services and Charges

3892 - Midwest Color Printing, INC	12-250 Business Cards - T. Williams	05/10/2024	65.83
------------------------------------	-------------------------------------	------------	-------



Board of Public Works Claim Register

Invoice Date Range 04/27/24 - 05/10/24

53442 - Paragon Micro, INC	12-laptop, docking station, briefcase for Ass't HR Director	05/10/2024	1,734.97
53442 - Paragon Micro, INC	12-2 Dell Monitors for Ass't HR Director	05/10/2024	279.98
Account 53990 - Other Services and Charges Totals		Invoice 3	<u>\$2,080.78</u>
Program 120000 - Main Totals		Transactions Invoice 4	<u>\$2,127.80</u>
Department 12 - Human Resources Totals		Transactions Invoice 4	<u>\$2,127.80</u>
Department 13 - Planning		Transactions	
Program 130000 - Main			
Account 52410 - Books			
8541 - Amazon.com Sales, INC (Amazon.com Services LLC)	13-Credit for Pre-order Guarantee of book ordered	05/10/2024	(1.16)
8541 - Amazon.com Sales, INC (Amazon.com Services LLC)	13-Escaping The Housing Trap Book for Director of P&T	05/10/2024	21.66
Account 52410 - Books Totals		Invoice 2	<u>\$20.50</u>
Account 53210 - Telephone		Transactions	
13969 - AT&T Mobility II, LLC	06-cell phone chgs 03/12-04/11/24-Inv. 287297421132X04192024	05/01/2024	368.46
Account 53210 - Telephone Totals		Invoice 1	<u>\$368.46</u>
Account 53320 - Advertising		Transactions	
9241 - Gannett Media Corp (Gannett Indiana/Kentucky)	13- Legal Ads for ZO-04-24 through ZO-07-24 for Plan Commission	05/10/2024	74.00
Account 53320 - Advertising Totals		Invoice 1	<u>\$74.00</u>
Account 53990 - Other Services and Charges		Transactions	
6235 - Toole Design Group, LLC	13-Corridor Study_College & Walnut - 45/46 Bypass- thru 03/29/24	BC 2022-086 05/10/2024	1,970.23
6235 - Toole Design Group, LLC	13- Safe Streets and Roads for All Action Plan through 03/29/24	BC 2023-036 05/10/2024	23,447.02
Account 53990 - Other Services and Charges Totals		Invoice 2	<u>\$25,417.25</u>
Program 130000 - Main Totals		Transactions Invoice 6	<u>\$25,880.21</u>
Program 131000 - Environmental		Transactions	



Board of Public Works Claim Register

Invoice Date Range 04/27/24 - 05/10/24

Account 52420 - Other Supplies

651 - Engraving & Stamp Center, INC	13- Ribbon Stock for Eco Heroes gifts		05/10/2024	6.72
50796 - Margaret A Taylor (Book Corner)	13-Gifts for Eco Heroes Contest		05/10/2024	251.89
Account 52420 - Other Supplies Totals		Invoice 2		\$258.61
		Transactions		
Program 131000 - Environmental Totals		Invoice 2		\$258.61
		Transactions		

Program 132000 - MPO

Account 53990 - Other Services and Charges

3414 - Burgess & Niple, INC	13- BMCMP0 2050 Transportation Plan 03/01/24-03/31/24	BC 2023-082	05/10/2024	17,000.00
Account 53990 - Other Services and Charges Totals		Invoice 1		\$17,000.00
		Transactions		
Program 132000 - MPO Totals		Invoice 1		\$17,000.00
		Transactions		
Department 13 - Planning Totals		Invoice 9		\$43,138.82
		Transactions		

Department 19 - Facilities Maintenance

Program 190000 - Main

Account 52310 - Building Materials and Supplies

8541 - Amazon.com Sales, INC (Amazon.com Services LLC)	19 - Lockboxes and vacuum cleaner		05/10/2024	285.70
409 - Black Lumber Co. INC	19- 2x4-10 construction lumber for facilities		05/10/2024	5.15
409 - Black Lumber Co. INC	19 - box of Paslode 1.50" angle finish 2M		05/10/2024	29.97
409 - Black Lumber Co. INC	19 - Makita 18V blower tool only & Polarized sawhorse glasses		05/10/2024	134.94
1537 - Indiana Door & Hardware Specialties, INC	19 - High security keyway lock cores for stock (20)	BC 2023-076	05/10/2024	1,340.00
4574 - John Deere Financial f.s.b. (Rural King)	19 - (5) 9ft tilt patio umbrella		05/10/2024	199.95
8658 - Kleindorfer's Hardware LLC	19 - paint roller, handle & tray, pik stiks, screws, nuts, bolts		05/10/2024	122.25
8658 - Kleindorfer's Hardware LLC	19 - 75' glamour pro garden hose		05/10/2024	59.99
Account 52310 - Building Materials and Supplies Totals		Invoice 8		\$2,177.95
		Transactions		



Board of Public Works Claim Register

Invoice Date Range 04/27/24 - 05/10/24

Account 52430 - Uniforms and Tools

19171 - Aramark Uniform & Career Apparel Group, INC	19 - Pants for R. Flake - 4/11/2024		05/10/2024	12.91
19171 - Aramark Uniform & Career Apparel Group, INC	19 - Work pants for R. Flake - 4/18/2024		05/10/2024	14.20
4574 - John Deere Financial f.s.b. (Rural King)	19-Powertrain Sport AT Blk 9.5W For Brighten B-Town		05/10/2024	109.95
4574 - John Deere Financial f.s.b. (Rural King)	19-Water & Clear drum liners For Brighten B-Town		05/10/2024	88.63

Account 52430 - Uniforms and Tools Totals	Invoice 4 Transactions	<u>\$225.69</u>
--	------------------------	-----------------

Account 53140 - Exterminator Services

51538 - Economy Termite & Pest Control, INC	19-monthly pest control-counsel office - 4/16/24	BC 2023-070	05/10/2024	75.00
---	--	-------------	------------	-------

Account 53140 - Exterminator Services Totals	Invoice 1 Transactions	<u>\$75.00</u>
---	------------------------	----------------

Account 53210 - Telephone

13969 - AT&T Mobility II, LLC	06-cell phone chgs 03/12-04/11/24-Inv. 287289748780X04192024		05/01/2024	166.96
-------------------------------	--	--	------------	--------

Account 53210 - Telephone Totals	Invoice 1 Transactions	<u>\$166.96</u>
---	------------------------	-----------------

Account 53610 - Building Repairs

321 - Harrell Fish, INC (HFI)	19 - SA City Hall new water cooler and bottle filler- 3/5/24	BC 2023-075	05/10/2024	2,381.08
321 - Harrell Fish, INC (HFI)	19 - SA City Hall quarterly HVAC maintenance April 2024	BC 2023-074	05/10/2024	2,088.00

Account 53610 - Building Repairs Totals	Invoice 2 Transactions	<u>\$4,469.08</u>
--	------------------------	-------------------

Account 54510 - Other Capital Outlays

8541 - Amazon.com Sales, INC (Amazon.com Services LLC)	19 - Test chair for Allison conference room		05/10/2024	99.97
--	---	--	------------	-------

Account 54510 - Other Capital Outlays Totals	Invoice 1 Transactions	<u>\$99.97</u>
---	------------------------	----------------

Program 190000 - Main Totals	Invoice 17 Transactions	<u>\$7,214.65</u>
-------------------------------------	-------------------------	-------------------

Department 19 - Facilities Maintenance Totals	Invoice 17 Transactions	<u>\$7,214.65</u>
--	-------------------------	-------------------

Department 28 - ITS

Program 280000 - Main



Board of Public Works Claim Register

Invoice Date Range 04/27/24 - 05/10/24

Account 52110 - Office Supplies

6530 - Office Depot, INC	28- 2024 Copy Paper Supply at Shower Building-10 cases	05/10/2024	384.00
	Account 52110 - Office Supplies Totals	Invoice 1	<u>\$384.00</u>
		Transactions	

Account 52420 - Other Supplies

8541 - Amazon.com Sales, INC (Amazon.com Services LLC)	28-GIS Office Light Bulbs	05/10/2024	17.99
	Account 52420 - Other Supplies Totals	Invoice 1	<u>\$17.99</u>
		Transactions	

Account 53170 - Mgt. Fee, Consultants, and Workshops

7389 - Info-tech Research Group INC	28-Advisory bundle subscription 5/13/24-5/13/25	05/10/2024	28,044.00
	Account 53170 - Mgt. Fee, Consultants, and Workshops Totals	Invoice 1	<u>\$28,044.00</u>
		Transactions	

Account 53210 - Telephone

13969 - AT&T Mobility II, LLC	06-cell phone chgs 03/12-04/11/24-Inv. 287297421132X04192024	05/01/2024	119.42
13969 - AT&T Mobility II, LLC	06-cell phone chgs 03/12-04/11/24-Inv. 287289748780X04192024	05/01/2024	680.52
1079 - AT&T	28-phone charges 03/20/24-04/19/24-#812 339-2261 261 1	05/01/2024	6,155.10
	Account 53210 - Telephone Totals	Invoice 3	<u>\$6,955.04</u>
		Transactions	

Account 53910 - Dues and Subscriptions

8690 - DocuSign, INC	28- Annual 17 Licenses 4-20-24 to 4-19-25	05/10/2024	5,354.40
8315 - Indiana Geographic Information Council, INC	28-2024 Membership Renewal - 7 Members (thru 6/15/25)	05/10/2024	750.00
8441 - Promevo Holdings, INC (Promevo, LLC)	28-Google Enterprise & gPanel Renewal & Arch 04/10/24-01/25/25	05/10/2024	717.55
	Account 53910 - Dues and Subscriptions Totals	Invoice 3	<u>\$6,821.95</u>
	Program 280000 - Main Totals	Transactions Invoice 9	<u>\$42,222.98</u>
	Department 28 - ITS Totals	Transactions Invoice 9	<u>\$42,222.98</u>
	Fund 101 - General Fund (S0101) Totals	Transactions Invoice 130	<u>\$227,332.95</u>
		Transactions	

Fund 103 - Restricted Donations(ord 05-17)



Board of Public Works Claim Register

Invoice Date Range 04/27/24 - 05/10/24

Department **06 - Controller's Office**
 Program **400101 - Animal Medical Services**
 Account **53130 - Medical**

6529 - BloomingPaws, LLC	01-Follow-up exam & x-rays-Barry B. Benson	05/10/2024	100.00
6529 - BloomingPaws, LLC	01-X-rays with barium-Barry B Benson	05/10/2024	576.00
	Account 53130 - Medical Totals	Invoice 2	<u>\$676.00</u>
	Program 400101 - Animal Medical Services Totals	Transactions Invoice 2	<u>\$676.00</u>
	Department 06 - Controller's Office Totals	Transactions Invoice 2	<u>\$676.00</u>
	Fund 103 - Restricted Donations(ord 05-17) Totals	Transactions Invoice 2	<u>\$676.00</u>
		Transactions	

Fund **152 - Food & Beverage Tax(S9509)**

Department **06 - Controller's Office**
 Program **060000 - Main**
 Account **53990 - Other Services and Charges**

9279 - Monroe County Capital Improvement Board (CIB)	06 City's portion Convention Center Proj-Nov 23-March 24	05/10/2024	44,089.37
	Account 53990 - Other Services and Charges Totals	Invoice 1	<u>\$44,089.37</u>
	Program 060000 - Main Totals	Transactions Invoice 1	<u>\$44,089.37</u>
	Department 06 - Controller's Office Totals	Transactions Invoice 1	<u>\$44,089.37</u>
	Fund 152 - Food & Beverage Tax(S9509) Totals	Transactions Invoice 1	<u>\$44,089.37</u>
		Transactions	

Fund **153 - LIT – Economic Development**

Department **04 - Economic & Sustainable Dev**
 Program **040000 - Main**
 Account **53960 - Grants**

5695 - 1818 Apparel Co., INC (dba Freethink Apparel)	04- Go Hoosiers T-Shirts for Go Bloomington Promo Event 1 (120)	05/10/2024	1,218.00
--	---	------------	----------



Board of Public Works Claim Register

Invoice Date Range 04/27/24 - 05/10/24

5695 - 1818 Apparel Co., INC (dba Freethink AppareI)	04-Go Hoosiers T-Shirts for Go Bloomington Promo Event 2 (120)		05/10/2024	1,218.00
5695 - 1818 Apparel Co., INC (dba Freethink AppareI)	04-Go Hoosiers T-Shirts for Go Bloomington Promo (120)		05/10/2024	1,218.00
9129 - Babel INC	04-BAC Public Art Grant - Ana Candida Carneiro		05/10/2024	800.00
4505 - Bicycle Garage, INC	04-E-Bike Voucher Program 04/12/24		05/10/2024	1,000.00
205 - City Of Bloomington	04-Mobile Stage Rental for Earth Day Event-4/20/24		05/10/2024	110.00
7645 - Farmer House Museum INC	04-BAC Public Art Grant - Emily Purcell		05/10/2024	1,000.00
6805 - Greater Indiana Clean Cities, INC	04-Event Services for Earth Day Event April-2024		05/10/2024	834.45
6330 - Marshall Security LLC	04-Security for 2024 Earth Day at Switchyard Park		05/10/2024	750.00
4394 - Richardson Enterprises of Blgtn,LLC (FastSigns)	04- 2024 Earth Day Signs (4)		05/10/2024	238.03
4976 - Lewis Rogers	04- Entertainment for Bike to Earth Day 202-4/20/24		05/10/2024	1,500.00
54794 - Upland Brewing Co., INC	04-Beer & Wine Service-2024 Earth Day event-4/20/24		05/10/2024	400.00
	Account 53960 - Grants Totals		Invoice 12	<u>\$10,286.48</u>
	Program 040000 - Main Totals		Transactions Invoice 12	<u>\$10,286.48</u>
	Department 04 - Economic & Sustainable Dev Totals		Transactions Invoice 12	<u>\$10,286.48</u>
			Transactions	
Department 19 - Facilities Maintenance				
Program 190000 - Main				
Account 53990 - Other Services and Charges				
421 - Centerstone Of Indiana, INC	19-Cooperative Services Agreement -March 2024	Bc 2023-096	05/10/2024	27,866.52
421 - Centerstone Of Indiana, INC	19-Cooperative Services Agreement-Vehicle Lease-March 2024	BC 2023-096	05/10/2024	649.00
	Account 53990 - Other Services and Charges Totals		Invoice 2	<u>\$28,515.52</u>
	Program 190000 - Main Totals		Transactions Invoice 2	<u>\$28,515.52</u>
	Department 19 - Facilities Maintenance Totals		Transactions Invoice 2	<u>\$28,515.52</u>
	Fund 153 - LIT – Economic Development Totals		Transactions Invoice 14	<u>\$38,802.00</u>
			Transactions	



Board of Public Works Claim Register

Invoice Date Range 04/27/24 - 05/10/24

Fund **160 - IFA CoronaVirus Relief Fnd21.019**

Department **06 - Controller's Office**

Program **G20018 - IFA Corona Virus Relief Fund**

Account **53990 - Other Services and Charges**

250 - Crowe LLP

12 - Classification and Compensation Study 2023 - August 2023	05/10/2024	24,058.00
Account 53990 - Other Services and Charges Totals	Invoice 1	<u>\$24,058.00</u>
Program G20018 - IFA Corona Virus Relief Fund Totals	Transactions Invoice 1	<u>\$24,058.00</u>
Department 06 - Controller's Office Totals	Transactions Invoice 1	<u>\$24,058.00</u>
Fund 160 - IFA CoronaVirus Relief Fnd21.019 Totals	Transactions Invoice 1	<u>\$24,058.00</u>
	Transactions	

Fund **312 - Community Services**

Department **09 - CFRD**

Program **090016 - Com Serv - Safe & Civil**

Account **52420 - Other Supplies**

11693 - The Award Center, INC

09-Visionary Leader Award Replacement for James Saunders	05/10/2024	70.00
Account 52420 - Other Supplies Totals	Invoice 1	<u>\$70.00</u>
Program 090016 - Com Serv - Safe & Civil Totals	Transactions Invoice 1	<u>\$70.00</u>
Department 09 - CFRD Totals	Transactions Invoice 1	<u>\$70.00</u>
Fund 312 - Community Services Totals	Transactions Invoice 1	<u>\$70.00</u>
	Transactions	

Fund **401 - Non-Reverting Telecom (S1146)**

Department **25 - Telecommunications**

Program **256000 - Services**

Account **53150 - Communications Contract**

4170 - Comcast Cable Communications, INC

28 - 3550 N. Kinser Cascades Clubhouse-04/27/24-05/26/24	05/01/2024	110.35
--	------------	--------



Board of Public Works Claim Register

Invoice Date Range 04/27/24 - 05/10/24

Account 53150 - Communications Contract Totals		Invoice 1	\$110.35
Account 54450 - Equipment		Transactions	
8541 - Amazon.com Sales, INC (Amazon.com Services LLC)	28-Power Bank Credit Wrong Item in Box	05/10/2024	(170.99)
6222 - Apple, INC	28-CAPR for Mayors Office-IPad & IPad Pro	05/10/2024	2,028.00
53442 - Paragon Micro, INC	28-CAPR MACs w/ Apple Care for Cabinet & Council	05/10/2024	2,429.99
Account 54450 - Equipment Totals		Invoice 3	\$4,287.00
Program 256000 - Services Totals		Transactions	
Department 25 - Telecommunications Totals		Invoice 4	\$4,397.35
Fund 401 - Non-Reverting Telecom (S1146) Totals		Transactions	
Fund 451 - Motor Vehicle Highway(S0708)		Invoice 4	\$4,397.35
Department 20 - Street		Transactions	
Program 200000 - Main		Invoice 4	\$4,397.35
Account 52210 - Institutional Supplies		Transactions	
313 - Fastenal Company	20-Safety Supplies- ape measure, safety glasses, earplugs	05/10/2024	127.59
313 - Fastenal Company	20- Safety Supplies for Crews-gloves, safety glasses, earplugs	05/10/2024	203.87
Account 52210 - Institutional Supplies Totals		Invoice 2	\$331.46
Account 52340 - Other Repairs and Maintenance		Transactions	
32 - Cassidy Electrical Contractors, INC	20-SA Plug in breaker 50A 2P	BC 2023-068 05/10/2024	218.91
395 - Kirby Risk Corp	20-120V Plug ins (3) for signal cabinet repairs	05/10/2024	59.89
Account 52340 - Other Repairs and Maintenance Totals		Invoice 2	\$278.80
Account 52420 - Other Supplies		Transactions	
409 - Black Lumber Co. INC	20-Hardware, Pro google, adj face shield for concrete/asphalt cr	05/10/2024	119.87
409 - Black Lumber Co. INC	20-Scotts Thick Lawn 1200 Sq ft for tree crew	05/10/2024	26.97



Board of Public Works Claim Register

Invoice Date Range 04/27/24 - 05/10/24

409 - Black Lumber Co. INC	20-4x8-3/4 AC Sand Pine for walkboards/pave crew	05/10/2024	53.19
409 - Black Lumber Co. INC	20-DB 7 Cup Wheel for Sidewalk Crew	05/10/2024	89.99
409 - Black Lumber Co. INC	20-(3) 2"X 55YD Silver Duct Tape for Milling Machine	05/10/2024	8.91
409 - Black Lumber Co. INC	20-1/4" X 2 1/4 hex protwist for 413 S. Henderson sidewalk plate	05/10/2024	19.99
409 - Black Lumber Co. INC	20-(4) 1x4 10 pine pro	05/10/2024	19.96
409 - Black Lumber Co. INC	20-Bernzomatic self ignite torch for tackle wagon paving	05/10/2024	29.99
409 - Black Lumber Co. INC	20-(6) 2x4 10 cons lumber, (6) 1x4 10 pine pro for sidewalk proi	05/10/2024	61.44
11243 - Core & Main, LP	20-Concrete Curing Blankets for Concrete Crew	05/10/2024	609.44
293 - J&S Locksmith Shop, INC	20-Supplies for bush hog (filter, cover & spark plugs)	05/10/2024	29.52
4574 - John Deere Financial f.s.b. (Rural King)	20-Mowing supplies (handheld blower & line)	05/10/2024	189.97
8658 - Kleindorfer's Hardware LLC	20-Pressure washer and teflon tape for milling	05/10/2024	5.28
8658 - Kleindorfer's Hardware LLC	20-(4) rubber straps for patching	05/10/2024	6.36
8658 - Kleindorfer's Hardware LLC	20-(4) sprayers for paving	05/10/2024	139.96
8658 - Kleindorfer's Hardware LLC	20-(2) safety hose, chain, clevis for street cuts	05/10/2024	70.47
2974 - MacAllister Machinery Co, INC	20-Plate scale for paver (Part# 4303918)	05/10/2024	185.76
53442 - Paragon Micro, INC	20-Fujitsu fi-8040 Doc Scanner	05/10/2024	499.99
Account 52420 - Other Supplies Totals		Invoice 18 Transactions	\$2,167.06
Account 53210 - Telephone			
13969 - AT&T Mobility II, LLC	06-cell phone chgs 03/12-04/11/24-Inv. 287297421132X04192024	05/01/2024	130.22
13969 - AT&T Mobility II, LLC	06-cell phone chgs 03/12-04/11/24-Inv. 287289748780X04192024	05/01/2024	208.70
Account 53210 - Telephone Totals		Invoice 2 Transactions	\$338.92
Account 53540 - Natural Gas			
222 - Indiana Gas Co. INC (CenterPoint Energy) (Vectren)	20-Traffic bldg-gas bill 03/06/24-04/04/24	04/29/2024	74.69



Board of Public Works Claim Register

Invoice Date Range 04/27/24 - 05/10/24

222 - Indiana Gas Co. INC (CenterPoint Energy) (Vectren)	20-Street Dept-gas bill 03/06/24-04/04/24	04/29/2024	161.01
	Account 53540 - Natural Gas Totals	Invoice 2	<hr/> \$235.70
		Transactions	
Account 53610 - Building Repairs			
321 - Harrell Fish, INC (HFI)	20- Replaced fuse in thermostat -3/25/24	BC 2023-074 05/10/2024	274.51
	Account 53610 - Building Repairs Totals	Invoice 1	<hr/> \$274.51
		Transactions	
Account 53920 - Laundry and Other Sanitation Services			
19171 - Aramark Uniform & Career Apparel Group, INC	20-uniform rental (minus payroll ded)-4/17/24	05/10/2024	9.01
19171 - Aramark Uniform & Career Apparel Group, INC	20-mat/towel service-4/17/24	05/10/2024	42.58
19171 - Aramark Uniform & Career Apparel Group, INC	20-uniform rental (minus payroll ded)-4/24/24	05/10/2024	9.01
19171 - Aramark Uniform & Career Apparel Group, INC	20-mat/towel service-4/24/24	05/10/2024	42.58
	Account 53920 - Laundry and Other Sanitation Services Totals	Invoice 4	<hr/> \$103.18
		Transactions	
Account 53950 - Landfill			
52226 - Hoosier Transfer Station-3140	20-Landfill fees for sweeper dumps 03/26/24	05/10/2024	1,179.74
	Account 53950 - Landfill Totals	Invoice 1	<hr/> \$1,179.74
		Transactions	
Account 53990 - Other Services and Charges			
902 - Indiana Underground Plant Protection Service, INC	20-Line Locate Ticket Services for March 2024 (870)	05/10/2024	826.50
	Account 53990 - Other Services and Charges Totals	Invoice 1	<hr/> \$826.50
		Transactions	
	Program 200000 - Main Totals	Invoice 33	<hr/> \$5,735.87
		Transactions	
	Department 20 - Street Totals	Invoice 33	<hr/> \$5,735.87
		Transactions	
	Fund 451 - Motor Vehicle Highway(S0708) Totals	Invoice 33	<hr/> \$5,735.87
		Transactions	
Fund 452 - Parking Facilities(S9502)			
Department 26 - Parking			
Program 260000 - Main			



Board of Public Works Claim Register

Invoice Date Range 04/27/24 - 05/10/24

Account 52310 - Building Materials and Supplies

8658 - Kleindorfer's Hardware LLC	26-Rollers and Buckets for Parking		05/10/2024	65.32
-----------------------------------	------------------------------------	--	------------	-------

Account 52310 - Building Materials and Supplies Totals		Invoice 1		\$65.32
		Transactions		

Account 52420 - Other Supplies

8541 - Amazon.com Sales, INC (Amazon.com Services LLC)	26-walkie talkies and caution tape for solar eclipse event		05/10/2024	100.95
--	--	--	------------	--------

3397 - Evens Time, INC	26-receipt paper for all parking equipment	BC 2024-003	05/10/2024	918.37
------------------------	--	-------------	------------	--------

Account 52420 - Other Supplies Totals		Invoice 2		\$1,019.32
		Transactions		

Account 53210 - Telephone

13969 - AT&T Mobility II, LLC	06-cell phone chgs 03/12-04/11/24-Inv. 287289748780X04192024		05/01/2024	166.96
-------------------------------	--	--	------------	--------

Account 53210 - Telephone Totals		Invoice 1		\$166.96
		Transactions		

Account 53540 - Natural Gas

222 - Indiana Gas Co. INC (CenterPoint Energy) (Vectren)	26-Trades Garage-489 W. 10th-gas bill 03/01-04/01/24		04/29/2024	48.77
--	--	--	------------	-------

222 - Indiana Gas Co. INC (CenterPoint Energy) (Vectren)	26-4th St Garage-105 W. 4th St-gas bill 03/01/24-04/01/24		04/29/2024	48.77
--	---	--	------------	-------

Account 53540 - Natural Gas Totals		Invoice 2		\$97.54
		Transactions		

Account 53610 - Building Repairs

3397 - Evens Time, INC	26-Walnut St Garage entry hit, didn't have part on hand-4/5/24	BC 2024-003	05/10/2024	692.92
------------------------	--	-------------	------------	--------

392 - Koorsen Fire & Security, INC	26-4th St Gar-annual fire alarm, sprinkler & backflow inspection	BC 2023-089	05/10/2024	689.88
------------------------------------	--	-------------	------------	--------

Account 53610 - Building Repairs Totals		Invoice 2		\$1,382.80
		Transactions		

Program 260000 - Main Totals		Invoice 8		\$2,731.94
		Transactions		

Department 26 - Parking Totals		Invoice 8		\$2,731.94
		Transactions		

Fund 452 - Parking Facilities(S9502) Totals		Invoice 8		\$2,731.94
		Transactions		

Fund 454 - Alternative Transport(S6301)

Department 05 - Common Council



Board of Public Works Claim Register

Invoice Date Range 04/27/24 - 05/10/24

Program **050000 - Main**

Account **54310 - Improvements Other Than Building**

10 - Bledsoe Riggert Cooper & James INC	07-Liberty Drive Sidewalk 03/31/24	BC 2022-069	05/10/2024	395.00
	Account 54310 - Improvements Other Than Building Totals		Invoice 1	<u>\$395.00</u>
			Transactions	
	Program 050000 - Main Totals		Invoice 1	<u>\$395.00</u>
			Transactions	
	Department 05 - Common Council Totals		Invoice 1	<u>\$395.00</u>
			Transactions	

Department **07 - Engineering**

Program **070000 - Main**

Account **53110 - Engineering and Architectural**

5999 - The Etica Group, INC	07-Downtown Curb Ramps Ph IV Assessment -March 2024	Bc 2021-025	05/10/2024	6,951.00
	Account 53110 - Engineering and Architectural Totals		Invoice 1	<u>\$6,951.00</u>
			Transactions	
	Program 070000 - Main Totals		Invoice 1	<u>\$6,951.00</u>
			Transactions	
	Department 07 - Engineering Totals		Invoice 1	<u>\$6,951.00</u>
			Transactions	

Department **26 - Parking**

Program **260000 - Main**

Account **52430 - Uniforms and Tools**

5695 - 1818 Apparel Co., INC (dba Freethink AppareI)	26-uniforms for Miles and Heath-polo shirts (10)		05/10/2024	115.00
	Account 52430 - Uniforms and Tools Totals		Invoice 1	<u>\$115.00</u>
			Transactions	

Account **53210 - Telephone**

13969 - AT&T Mobility II, LLC	06-cell phone chgs 03/12-04/11/24-Inv. 287289748780X04192024		05/01/2024	218.94
	Account 53210 - Telephone Totals		Invoice 1	<u>\$218.94</u>
			Transactions	

Account **53310 - Printing**

8002 - Safeguard Business Systems, INC	26-window envelopes (5,000) to send invoices to customers		05/10/2024	278.36
--	---	--	------------	--------



Board of Public Works Claim Register

Invoice Date Range 04/27/24 - 05/10/24

Account 53310 - Printing Totals		Invoice 1	\$278.36
Program 260000 - Main Totals		Transactions Invoice 3	\$612.30
Department 26 - Parking Totals		Transactions Invoice 3	\$612.30
Fund 454 - Alternative Transport(S6301) Totals		Transactions Invoice 5	\$7,958.30
Transactions			
Fund 455 - Parking Meter Fund(S2141)			
Department 26 - Parking			
Program 260000 - Main			
Account 52110 - Office Supplies			
8541 - Amazon.com Sales, INC (Amazon.com Services LLC)	26-certificate frame for parking services wall	05/10/2024	9.98
Account 52110 - Office Supplies Totals		Invoice 1	\$9.98
Account 52340 - Other Repairs and Maintenance		Transactions	
4264 - IPS Group, INC	26-replacement glass for kiosk damage	05/10/2024	152.38
Account 52340 - Other Repairs and Maintenance Totals		Invoice 1	\$152.38
Account 52420 - Other Supplies		Transactions	
8658 - Kleindorfer's Hardware LLC	26-Spray bottle, materials for parking meters	05/10/2024	1.99
8658 - Kleindorfer's Hardware LLC	26-Blue paint for ADA spaces	05/10/2024	72.42
8658 - Kleindorfer's Hardware LLC	26-4 bundles of wood stakes for posting special events	05/10/2024	180.00
Account 52420 - Other Supplies Totals		Invoice 3	\$254.41
Account 52430 - Uniforms and Tools		Transactions	
5695 - 1818 Apparel Co., INC (dba Freethink AppareI)	26-clothes for parking officers-shorts, pants, polos, jackets	05/10/2024	661.00
5695 - 1818 Apparel Co., INC (dba Freethink AppareI)	26-uniforms for Miles and Heath-polo shirts (10)	05/10/2024	115.00
5695 - 1818 Apparel Co., INC (dba Freethink AppareI)	26-uniforms for Walling-jacket and cargo shorts (3)	05/10/2024	195.00
4489 - J.L. Waters & Company, INC	26-safety shoes- P. McLaughlin (11.5M)-3/28/24	05/10/2024	100.00



Board of Public Works Claim Register

Invoice Date Range 04/27/24 - 05/10/24

Account 52430 - Uniforms and Tools Totals		Invoice 4	\$1,071.00
Account 53210 - Telephone		Transactions	
13969 - AT&T Mobility II, LLC	06-cell phone chgs 03/12-04/11/24-Inv. 287297421132X04192024	05/01/2024	122.82
13969 - AT&T Mobility II, LLC	06-cell phone chgs 03/12-04/11/24-Inv. 287289748780X04192024	05/01/2024	750.80
Account 53210 - Telephone Totals		Invoice 2	\$873.62
Account 53310 - Printing		Transactions	
4394 - Richardson Enterprises of Blgtn,LLC (FastSigns)	26-100 N Walnut-reflective directional arrows for meters (100)	05/10/2024	106.45
8002 - Safeguard Business Systems, INC	26-window envelopes (5,000) to send invoices to customers	05/10/2024	278.36
Account 53310 - Printing Totals		Invoice 2	\$384.81
Account 53990 - Other Services and Charges		Transactions	
4394 - Richardson Enterprises of Blgtn,LLC (FastSigns)	26-Zone 10 sign replacements (43)-incl tube posts/hardware/insta	05/10/2024	6,326.48
4394 - Richardson Enterprises of Blgtn,LLC (FastSigns)	26-signs for West Showers lot	05/10/2024	4,878.96
4394 - Richardson Enterprises of Blgtn,LLC (FastSigns)	26-signs (6) for Showers West lot	05/10/2024	512.99
4443 - The Sherwin Williams Company	26-Paint for curbs on 100-700 W 7th St	05/10/2024	378.27
4443 - The Sherwin Williams Company	26-yellow paint for curb painting on E 4th and W 6th sts	05/10/2024	378.27
4443 - The Sherwin Williams Company	26-paint for ADA spaces on E. 4th/IN Ave-N. Morton St	05/10/2024	51.21
Account 53990 - Other Services and Charges Totals		Invoice 6	\$12,526.18
Program 260000 - Main Totals		Transactions	
Department 26 - Parking Totals		Invoice 19	\$15,272.38
Fund 455 - Parking Meter Fund(S2141) Totals		Transactions	
Fund 456 - MVH Restricted		Invoice 19	\$15,272.38
Department 20 - Street		Transactions	
Program 200000 - Main		Invoice 19	\$15,272.38
		Transactions	



Board of Public Works Claim Register

Invoice Date Range 04/27/24 - 05/10/24

Account **52330 - Street , Alley, and Sewer Material**

5149 - E&B Paving, INC	20-Tac oil for paving 04/24/24	BC 2023-093A	05/10/2024	894.10
334 - Irving Materials, INC	20-Concrete for Sidewalk Projects-Graywell & Cricket Knoll	BC 2024-012	05/10/2024	736.00
334 - Irving Materials, INC	20-Concrete for Sidewalk Projects-550 N Parkridge Rd	BC 2024-012	05/10/2024	967.00
334 - Irving Materials, INC	20-Concrete for Sidewalk Projects-5th St & Roosevelt	BC 2024-012	05/10/2024	632.00

Account 52330 - Street , Alley, and Sewer Material Totals	Invoice 4	<u>\$3,229.10</u>
Program 200000 - Main Totals	Transactions Invoice 4	<u>\$3,229.10</u>
Department 20 - Street Totals	Transactions Invoice 4	<u>\$3,229.10</u>
Fund 456 - MVH Restricted Totals	Transactions Invoice 4	<u>\$3,229.10</u>
	Transactions	

Fund **600 - Cumulative Cap Imprv(CIG)(S2379)**

Department **02 - Public Works**

Program **020000 - Main**

Account **52330 - Street , Alley, and Sewer Material**

365 - Rogers Group, INC	20-Stone for Street Projects 04/18/24		05/10/2024	547.92
-------------------------	---------------------------------------	--	------------	--------

Account 52330 - Street , Alley, and Sewer Material Totals	Invoice 1	<u>\$547.92</u>
Program 020000 - Main Totals	Transactions Invoice 1	<u>\$547.92</u>
Department 02 - Public Works Totals	Transactions Invoice 1	<u>\$547.92</u>
Fund 600 - Cumulative Cap Imprv(CIG)(S2379) Totals	Transactions Invoice 1	<u>\$547.92</u>
	Transactions	

Fund **601 - Cumulative Capital Devlp(S2391)**

Department **02 - Public Works**

Program **020000 - Main**

Account **52330 - Street , Alley, and Sewer Material**

5149 - E&B Paving, INC	20-surface-North Washington St 03/25/24	BC 2023-093A	05/10/2024	195.16
------------------------	---	--------------	------------	--------



Board of Public Works Claim Register

Invoice Date Range 04/27/24 - 05/10/24

9194 - Flynn Brothers Holdings, INC	20-Bulk Cold Patch 19.76 tons-04/15/24		05/10/2024	2,964.00
	Account 52330 - Street , Alley, and Sewer Material Totals		Invoice 2	<u>\$3,159.16</u>
			Transactions	
	Program 020000 - Main Totals		Invoice 2	<u>\$3,159.16</u>
			Transactions	
	Department 02 - Public Works Totals		Invoice 2	<u>\$3,159.16</u>
			Transactions	
Department 07 - Engineering				
Program 070000 - Main				
Account 54310 - Improvements Other Than Building				
10 - Bledsoe Riggert Cooper & James INC	07-Moores Creek/SE Park Trail (PE) 03/31/24	BC 2022-137	05/10/2024	882.50
	Account 54310 - Improvements Other Than Building Totals		Invoice 1	<u>\$882.50</u>
			Transactions	
	Program 070000 - Main Totals		Invoice 1	<u>\$882.50</u>
			Transactions	
	Department 07 - Engineering Totals		Invoice 1	<u>\$882.50</u>
			Transactions	
	Fund 601 - Cumulative Capital Devlp(S2391) Totals		Invoice 3	<u>\$4,041.66</u>
			Transactions	
Fund 730 - Solid Waste (S6401)				
Department 16 - Sanitation				
Program 160000 - Main				
Account 52430 - Uniforms and Tools				
8613 - Crane's Leather & Shoe Shop, INC	16-winter clothing and boots (size 10) for Robert East-11/2/23		05/10/2024	297.00
8613 - Crane's Leather & Shoe Shop, INC	16-winter clothing for Joe Morrow-11/2/2023		05/10/2024	300.00
8613 - Crane's Leather & Shoe Shop, INC	16-winter clothing and boots (size 11) for Larry Armes-11/4/23		05/10/2024	300.00
793 - Indiana Safety Company, INC	16-Safety vests and gloves for employees		05/10/2024	413.79
	Account 52430 - Uniforms and Tools Totals		Invoice 4	<u>\$1,310.79</u>
			Transactions	
Account 53210 - Telephone				
13969 - AT&T Mobility II, LLC	06-cell phone chgs 03/12-04/11/24-Inv. 287297421132X04192024		05/01/2024	419.36



Board of Public Works Claim Register

Invoice Date Range 04/27/24 - 05/10/24

13969 - AT&T Mobility II, LLC	06-cell phone chgs 03/12-04/11/24-Inv. 287289748780X04192024	05/01/2024	41.74
	Account 53210 - Telephone Totals	Invoice 2	<hr/> \$461.10
Account 53540 - Natural Gas		Transactions	
222 - Indiana Gas Co. INC (CenterPoint Energy) (Vectren)	16-Sanitation-gas bill 03/04/24-04/02/24	04/29/2024	199.01
	Account 53540 - Natural Gas Totals	Invoice 1	<hr/> \$199.01
Account 53610 - Building Repairs		Transactions	
321 - Harrell Fish, INC (HFI)	16-moved exterior wall vent away from gutter- 1/24/24	Bc 2023-074 05/10/2024	775.25
	Account 53610 - Building Repairs Totals	Invoice 1	<hr/> \$775.25
Account 53950 - Landfill		Transactions	
52226 - Hoosier Transfer Station-3140	16-trash disposal fees-04/01-04/15/24	05/10/2024	14,978.62
52226 - Hoosier Transfer Station-3140	16-recycling fees-04/01-04/15/2024	05/10/2024	942.70
	Account 53950 - Landfill Totals	Invoice 2	<hr/> \$15,921.32
	Program 160000 - Main Totals	Transactions Invoice 10	<hr/> \$18,667.47
	Department 16 - Sanitation Totals	Transactions Invoice 10	<hr/> \$18,667.47
	Fund 730 - Solid Waste (S6401) Totals	Transactions Invoice 10	<hr/> \$18,667.47
		Transactions	
Fund 800 - Risk Management(S0203)			
Department 10 - Legal			
Program 100000 - Main			
Account 52430 - Uniforms and Tools			
8613 - Crane's Leather & Shoe Shop, INC	10-safety shoes-A. Boden (12M)-4/17/24	05/10/2024	100.00
8613 - Crane's Leather & Shoe Shop, INC	10-safety shoes-G. Dobbs (10D)-4/17/24	05/10/2024	100.00
8613 - Crane's Leather & Shoe Shop, INC	10-safety shoes-C. Eagan (9.5M)-4/17/24	05/10/2024	100.00
8613 - Crane's Leather & Shoe Shop, INC	10-safety shoes-D. Fleener (10.5D)-4/16/24	05/10/2024	100.00



Board of Public Works Claim Register

Invoice Date Range 04/27/24 - 05/10/24

8613 - Crane's Leather & Shoe Shop, INC	10-safety shoes-J. Hardin (13D)-4/10/24	05/10/2024	100.00
8613 - Crane's Leather & Shoe Shop, INC	10-safety shoes-J. Hazel (10.5D)-4/16/24	05/10/2024	100.00
8613 - Crane's Leather & Shoe Shop, INC	10-safety shoes-G. Hill (11.5M)-4/17/24	05/10/2024	100.00
8613 - Crane's Leather & Shoe Shop, INC	10-safety shoes-B. Hume (10M)-4/4/24	05/10/2024	100.00
8613 - Crane's Leather & Shoe Shop, INC	10-safety shoes-K. Johnson (9D)-4/11/24	05/10/2024	100.00
8613 - Crane's Leather & Shoe Shop, INC	10-safety shoes-B. Kinser (11.5EE)-4/17/24	05/10/2024	100.00
8613 - Crane's Leather & Shoe Shop, INC	10-safety shoes-P. Lagenour (10.5D)-4/17/24	05/10/2024	100.00
8613 - Crane's Leather & Shoe Shop, INC	10-safety shoes-D. Lavender (11M)-4/11/24	05/10/2024	100.00
8613 - Crane's Leather & Shoe Shop, INC	10-safety shoes-E. Maddy (7.5W)-4/15/24	05/10/2024	100.00
8613 - Crane's Leather & Shoe Shop, INC	10-safety shoes-M> Marotz (9D)-4/16/24	05/10/2024	100.00
8613 - Crane's Leather & Shoe Shop, INC	10-safety shoes-J. McIntrye (10.5D)-4/16/24	05/10/2024	100.00
8613 - Crane's Leather & Shoe Shop, INC	10-safety shoes-J. Morrow (12M)-4/16/24	05/10/2024	100.00
8613 - Crane's Leather & Shoe Shop, INC	10-safety shoes-T. Myers (11.5D)-4/17/24	05/10/2024	100.00
8613 - Crane's Leather & Shoe Shop, INC	10-safety shoes-C. Nichols (8.5M)-4/12/24	05/10/2024	100.00
8613 - Crane's Leather & Shoe Shop, INC	10-safety shoes-B. Norman (13D)-4/11/24	05/10/2024	100.00
8613 - Crane's Leather & Shoe Shop, INC	10-safety shoes-P. Paris (13D)-4/16/24	05/10/2024	100.00
8613 - Crane's Leather & Shoe Shop, INC	10-safety shoes-A. Robertson (14D)-4/16/24	05/10/2024	100.00
8613 - Crane's Leather & Shoe Shop, INC	10-safety shoes-S. Steele (6.5M)-4/16/24	05/10/2024	100.00
8613 - Crane's Leather & Shoe Shop, INC	10-safety shoes-C. Swofford (7.5M)-4/15/24	05/10/2024	100.00
8613 - Crane's Leather & Shoe Shop, INC	10-safety shoes-J. Troxell (8D)-4/17/24	05/10/2024	100.00
8613 - Crane's Leather & Shoe Shop, INC	10-safety shoes-R. Turpin (8D)-4/16/24	05/10/2024	100.00
8613 - Crane's Leather & Shoe Shop, INC	10-safety shoes-J. Wenning (12D)-4/15/24	05/10/2024	97.50
8613 - Crane's Leather & Shoe Shop, INC	10-safety shoes-J. Zike (10M)-4/11/24	05/10/2024	100.00



Board of Public Works Claim Register

Invoice Date Range 04/27/24 - 05/10/24

8613 - Crane's Leather & Shoe Shop, INC	10-safety shoes-B. East (11D)-4/18/24	05/10/2024	97.50
8613 - Crane's Leather & Shoe Shop, INC	10-safety shoes-B. Elkins Sr. (11D)-4/22/24	05/10/2024	100.00
8613 - Crane's Leather & Shoe Shop, INC	10-safety shoes-D. Klarich (11M)-4/20/24	05/10/2024	100.00
8613 - Crane's Leather & Shoe Shop, INC	10-safety shoes-D. Polson (10.5M)-4/22/24	05/10/2024	80.00
8613 - Crane's Leather & Shoe Shop, INC	10-safety shoes-D. Fields (11M)-4/22/24	05/10/2024	80.00
8613 - Crane's Leather & Shoe Shop, INC	10-safety shoes-K. Drescher (7.5M)-4/20/24	05/10/2024	100.00
8613 - Crane's Leather & Shoe Shop, INC	10-safety shoes-K. Fulford (12M)-4/18/24	05/10/2024	80.00
8613 - Crane's Leather & Shoe Shop, INC	10-safety shoes-K. Housel (13D)-4/18/24	05/10/2024	100.00
8613 - Crane's Leather & Shoe Shop, INC	10-safety shoes-K. White (9.5M)-4/18/24	05/10/2024	100.00
8613 - Crane's Leather & Shoe Shop, INC	10-safety shoes-M. Large (11.5M)-4/18/24	05/10/2024	80.00
8613 - Crane's Leather & Shoe Shop, INC	10-safety shoes-M. Hollingsworth (10M)-4/18/24	05/10/2024	100.00
8613 - Crane's Leather & Shoe Shop, INC	10-safety shoes-N. Rollins (6.5M)-4/19/24	05/10/2024	90.00
8613 - Crane's Leather & Shoe Shop, INC	10-safety shoes-R. Sanchez (11W)-4/18/24	05/10/2024	100.00
8613 - Crane's Leather & Shoe Shop, INC	10-safety shoes-R. Moore (8M)-4/19/24	05/10/2024	100.00
8613 - Crane's Leather & Shoe Shop, INC	10-safety shoes-T. Morrison (10.5D)-4/19/24	05/10/2024	100.00
1448 - Shoe Carnival, INC	10-safety shoes-Bray (11)-4/4/24	05/10/2024	100.00
1448 - Shoe Carnival, INC	10-safety shoes-Ketcham (11.5M)-3/22/24	05/10/2024	94.98
1448 - Shoe Carnival, INC	10-safety shoes-Livingston (13M)-3/22/24	05/10/2024	94.98

Account **52430 - Uniforms and Tools** Totals

Invoice 45
Transactions \$4,394.96

Account **53130 - Medical**

7346 - Ryan Pfeiffer	10-reimb for CDL physical-4/5/24	05/10/2024	100.00
----------------------	----------------------------------	------------	--------

Account **53130 - Medical** Totals

Invoice 1
Transactions \$100.00

Account **53420 - Worker's Comp & Risk**



Board of Public Works Claim Register

Invoice Date Range 04/27/24 - 05/10/24

7792 - ONB Benefit Administration LLC (JWF Specialty)	10- Workers Comp Invoice (03.21.2024-04.03.2024) BL041724	04/29/2024	2,986.14
7792 - ONB Benefit Administration LLC (JWF Specialty)	10- Workers Comp Invoice (04.04.2024-04.17.2024) BL041924	04/29/2024	4,750.91
	Account 53420 - Worker's Comp & Risk Totals	Invoice 2	<u>\$7,737.05</u>
	Program 100000 - Main Totals	Transactions Invoice 48	<u>\$12,232.01</u>
	Department 10 - Legal Totals	Transactions Invoice 48	<u>\$12,232.01</u>
	Fund 800 - Risk Management(S0203) Totals	Transactions Invoice 48	<u>\$12,232.01</u>
		Transactions	
Fund 801 - Health Insurance Trust			
Department 12 - Human Resources			
Program 120000 - Main			
Account 53990.1201 - Other Services and Charges Health Insurance			
17785 - The Howard E. Nyhart Company, INC	12-HSA ER Contrib; Breitzman, Carter, Harrison, Hittle. Moore	04/30/2024	6,704.50
17785 - The Howard E. Nyhart Company, INC	12-HSA ER Contributions; Ar buckle, Hershman, Kassamania. Stidd	04/30/2024	5,384.02
3928 - Aim Medical Trust	12 - May 2024 Medical Premiums	05/06/2024	1,082,483.17
	Account 53990.1201 - Other Services and Charges Health Insurance Totals	Invoice 3	<u>\$1,094,571.69</u>
	Program 120000 - Main Totals	Transactions Invoice 3	<u>\$1,094,571.69</u>
	Department 12 - Human Resources Totals	Transactions Invoice 3	<u>\$1,094,571.69</u>
	Fund 801 - Health Insurance Trust Totals	Transactions Invoice 3	<u>\$1,094,571.69</u>
		Transactions	
Fund 802 - Fleet Maintenance(S9500)			
Department 17 - Fleet Maintenance			
Program 170000 - Main			
Account 52110 - Office Supplies			
6530 - Office Depot, INC	17 - markers & hand soap	05/10/2024	34.38
6530 - Office Depot, INC	17 - mean streak markers, sharpie markers and storage case	05/10/2024	77.93



Board of Public Works Claim Register

Invoice Date Range 04/27/24 - 05/10/24

Account 52110 - Office Supplies Totals		Invoice 2 Transactions	\$112.31
Account 52230 - Garage and Motor Supplies			
50605 - Bauer Built, INC	17 - shop supplies,(8) metal valve stem & tire mount & dismount	05/10/2024	3,386.02
50605 - Bauer Built, INC	17 - Tire repairs & tire mount & dismount labor/purchase tires	05/10/2024	4,692.17
4693 - Monroe County Tire & Supply, INC	17 - R255/70R17 Yokohama Geo A/T Go15 Owl tires for 589	05/10/2024	400.50
Account 52230 - Garage and Motor Supplies Totals		Invoice 3 Transactions	\$8,478.69
Account 52320 - Motor Vehicle Repair			
244 - Bloomington Ford, INC	17 - AC switch assembly for 355	05/10/2024	75.27
244 - Bloomington Ford, INC	17 - TPMS sensor kit for 532	05/10/2024	250.88
244 - Bloomington Ford, INC	17 - Reservoir assembly for 638	05/10/2024	363.75
244 - Bloomington Ford, INC	17 - hardware kit for 638	05/10/2024	472.50
244 - Bloomington Ford, INC	17 - Fuel pump assembly for 495	05/10/2024	775.91
244 - Bloomington Ford, INC	17 - nox module C & D, nox trap sensor C & D for 638	05/10/2024	1,547.73
941 - Central Indiana Truck Equipment Corporation	17 - (2) inside cylinder & 5000/mltipak T/G RAI for 957	05/10/2024	4,474.93
594 - Curry Auto Center, INC	17 - SL-N-Filter for 462	05/10/2024	31.99
455 - Industrial Service & Supply, INC	17 - Protec Nylon hose sleeve & nylon hose sleeve for 4861	05/10/2024	74.75
455 - Industrial Service & Supply, INC	17 - JIC swivel female 90 & 45 deg, (2) straight ORB connectors	05/10/2024	171.55
455 - Industrial Service & Supply, INC	17 - T-Bolt clamp, steel ferrule, non-skive ferrule, double hex	05/10/2024	309.57
455 - Industrial Service & Supply, INC	17 - Protec Nylon hose sleeve & nylon hose sleeve for 4861	05/10/2024	31.50
796 - Interstate Battery System of Bloomington, INC	17-batteries-31-MHD, MTP-48/H6, MTP-65HD	05/10/2024	995.84
796 - Interstate Battery System of Bloomington, INC	17-batteries-31-MHD, MT-59, MTP-65HD, SP-30	05/10/2024	1,046.71
908 - JB Salvage (Westside Auto Parts)	17 - #4861 misc steel	05/10/2024	18.00
2974 - MacAllister Machinery Co, INC	17 - Element for 460	05/10/2024	39.74



Board of Public Works Claim Register

Invoice Date Range 04/27/24 - 05/10/24

2974 - MacAllister Machinery Co, INC	17 - Nozzle, cap, seal & filter for 460	05/10/2024	67.42
2974 - MacAllister Machinery Co, INC	17-mat-cocoa for 484	05/10/2024	128.70
2974 - MacAllister Machinery Co, INC	17 - Scraper Assembly for 460 + Emergency charge	05/10/2024	186.11
2974 - MacAllister Machinery Co, INC	17 - Support assembly for 484	05/10/2024	304.32
53385 - O'Reilly Automotive Stores, INC	17 - (4) Class 2 Vest for shop	05/10/2024	27.96
53385 - O'Reilly Automotive Stores, INC	17 - Capsule for Police Interceptor Sedan (191)	05/10/2024	53.54
53385 - O'Reilly Automotive Stores, INC	17 - credit for returned Air filter-Inv #1903-427323	05/10/2024	(41.99)
16069 - Palmer Trucks, INC	17 - Wiper Rotary switch 12V for 772	05/10/2024	120.88
16069 - Palmer Trucks, INC	17 - Rotary Wiper Switch, 12V for 774	05/10/2024	120.88
54351 - Sternberg, INC	17 - Light & harness for 429	05/10/2024	281.80
54351 - Sternberg, INC	17 - Turbo kit & core deposit for 395	05/10/2024	1,834.45
54351 - Sternberg, INC	17 - credit for Core returned	05/10/2024	(250.00)
54351 - Sternberg, INC	17 - credit for returned Turbo kit & Core deposit	05/10/2024	(1,853.04)
54351 - Sternberg, INC	17- #938 fuel pump repair	05/10/2024	705.02
582 - Town & Country Chrysler Dodge Jeep, INC	17 - Tire pressure sensor for 942	05/10/2024	120.70
7555 - VoMac Truck Sales & Service INC	17-pressure s for #958	05/10/2024	82.90
7555 - VoMac Truck Sales & Service INC	17 - glass for 957 and inventory	05/10/2024	258.32
7555 - VoMac Truck Sales & Service INC	17 - alternator for 474	05/10/2024	325.05
2096 - West Side Tractor Sales CO.	17 - washer for 655	05/10/2024	6.06
2096 - West Side Tractor Sales CO.	17 - joint for 655	05/10/2024	40.82
2096 - West Side Tractor Sales CO.	17 - Starter Relay for 655	05/10/2024	89.44
2096 - West Side Tractor Sales CO.	17-#608-change oil filter and fill fluids-4/10/24	05/10/2024	886.08
2096 - West Side Tractor Sales CO.	17-#608- 500 hour services, Fixed leak by replacing hoses	05/10/2024	2,314.16



Board of Public Works Claim Register

Invoice Date Range 04/27/24 - 05/10/24

Account	Description	Invoice	Date	Amount
Account 52320 - Motor Vehicle Repair Totals				
		Invoice 39		\$16,490.20
Account 52420 - Other Supplies				
409 - Black Lumber Co. INC	17 - 9" 8T carbide steel demon, 6"&12" 8T Diablo steel demon.		05/10/2024	222.70
8658 - Kleindorfer's Hardware LLC	17 - 40 bolts for 484		05/10/2024	14.00
8658 - Kleindorfer's Hardware LLC	17 - 1 1/4 galv barb & 1/4x1 1/2 bushing for 4861		05/10/2024	18.08
6216 - Terminal Supply, INC	17 - drill bits, recep, plug, jcase, aluminum oxide slow,		05/10/2024	151.37
Account 52420 - Other Supplies Totals				
		Invoice 4		\$406.15
Account 53140 - Exterminator Services				
51538 - Economy Termite & Pest Control, INC	17 - monthly pest control-4/16/2024	BC 2023-069	05/10/2024	95.00
Account 53140 - Exterminator Services Totals				
		Invoice 1		\$95.00
Account 53160 - Instruction				
5333 - Total Truck Parts, INC	17-INDY AC Clinic April 2024-training-Jones & Smith on HD/AC		05/10/2024	50.00
Account 53160 - Instruction Totals				
		Invoice 1		\$50.00
Account 53210 - Telephone				
13969 - AT&T Mobility II, LLC	06-cell phone chgs 03/12-04/11/24-Inv. 287289748780X04192024		05/01/2024	43.16
Account 53210 - Telephone Totals				
		Invoice 1		\$43.16
Account 53540 - Natural Gas				
222 - Indiana Gas Co. INC (CenterPoint Energy) (Vectren)	17-Fleet Maint-gas bill 03/06/23-04/06/23		04/29/2024	330.75
Account 53540 - Natural Gas Totals				
		Invoice 1		\$330.75
Account 53610 - Building Repairs				
321 - Harrell Fish, INC (HFI)	17 - Quarterly planned maintenance-1/29/24	BC 2023-074	05/10/2024	706.51
Account 53610 - Building Repairs Totals				
		Invoice 1		\$706.51
Account 53620 - Motor Repairs				



Board of Public Works Claim Register

Invoice Date Range 04/27/24 - 05/10/24

4474 - Ken's Westside Service & Towing, LLC	17-tire service- Unit #1220-4/19/24		05/10/2024	75.00
4474 - Ken's Westside Service & Towing, LLC	17-towing-2022 Dodge Charger-Unit #1240-4/16/24		05/10/2024	120.00
4474 - Ken's Westside Service & Towing, LLC	17-towing Unit #254-4/20/24		05/10/2024	120.00
4474 - Ken's Westside Service & Towing, LLC	17-towing Unit #958-4/22/24		05/10/2024	325.00
54351 - Sternberg, INC	17- #938 fuel pump repair		05/10/2024	588.00
2096 - West Side Tractor Sales CO.	17-#608-change oil filter and fill fluids-4/10/24		05/10/2024	842.92
2096 - West Side Tractor Sales CO.	17-#608- 500 hour services, Fixed leak by replacing hoses		05/10/2024	1,537.35
6476 - Samuel D Wray (Wray Automotive)	17 - #134 alignment		05/10/2024	100.00

Account **53620 - Motor Repairs** Totals Invoice 8 Transactions \$3,708.27

Account 53650 - Other Repairs

3286 - Peacetree, INC (PEI Maintenance)	17 - repairs to fuel master-S. Henderson-4/9/24	Bc 2022-058	05/10/2024	142.50
3286 - Peacetree, INC (PEI Maintenance)	17 - repairs to fuel master-S. Adams-4/9/24	Bc 2022-058	05/10/2024	190.00

Account **53650 - Other Repairs** Totals Invoice 2 Transactions \$332.50

Account 53920 - Laundry and Other Sanitation Services

19171 - Aramark Uniform & Career Apparel Group, INC	17 - City portion Of uniform rentals - 4/10/2024		05/10/2024	24.89
19171 - Aramark Uniform & Career Apparel Group, INC	17 - City portion Of uniform rentals - 4/17/2024		05/10/2024	25.89
19171 - Aramark Uniform & Career Apparel Group, INC	17 - mat rentals and shop towels-4/10/24		05/10/2024	93.35
19171 - Aramark Uniform & Career Apparel Group, INC	17 - Mat & towel rentals - 4/17/2024		05/10/2024	93.35

Account **53920 - Laundry and Other Sanitation Services** Totals Invoice 4 Transactions \$237.48

Account 53990 - Other Services and Charges

204 - State Of Indiana	17 - underground storage fees-Facility 2467 & 10168		05/10/2024	540.00
------------------------	---	--	------------	--------

Account **53990 - Other Services and Charges** Totals Invoice 1 Transactions \$540.00

Program **170000 - Main** Totals Invoice 68 Transactions \$31,531.02



Board of Public Works Claim Register

Invoice Date Range 04/27/24 - 05/10/24

Department 17 - Fleet Maintenance Totals		Invoice 68	\$31,531.02
Fund 802 - Fleet Maintenance(S9500) Totals		Transactions Invoice 68	\$31,531.02
		Transactions	
Fund 804 - Insurance Voluntary Trust			
Department 12 - Human Resources			
Program 120000 - Main			
Account 53990.1271 - Other Services and Charges Section 125 - URM- City			
17785 - The Howard E. Nyhart Company, INC	12-City URM	04/29/2024	152.87
17785 - The Howard E. Nyhart Company, INC	12-City URM	04/29/2024	428.26
17785 - The Howard E. Nyhart Company, INC	12-City URM	04/30/2024	175.81
17785 - The Howard E. Nyhart Company, INC	12-City URM	05/01/2024	55.00
Account 53990.1271 - Other Services and Charges Section 125 - URM- City Totals		Invoice 4	\$811.94
		Transactions Invoice 4	\$811.94
Program 120000 - Main Totals		Transactions Invoice 4	\$811.94
Department 12 - Human Resources Totals		Transactions Invoice 4	\$811.94
Fund 804 - Insurance Voluntary Trust Totals		Transactions Invoice 4	\$811.94
		Transactions	
Fund 978 - City 2016 GO Bond Proceeds			
Department 06 - Controller's Office			
Program 06016C - 2016 C Jackson Trail			
Account 54310 - Improvements Other Than Building			
399 - American Structurepoint, INC	07 - Jackson Creek Trail Phase II (CE) 03/01/24-03/31/24	BC 2023-029 05/10/2024	779.22
Account 54310 - Improvements Other Than Building Totals		Invoice 1	\$779.22
		Transactions Invoice 1	\$779.22
Program 06016C - 2016 C Jackson Trail Totals		Transactions Invoice 1	\$779.22
Department 06 - Controller's Office Totals		Transactions Invoice 1	\$779.22
Fund 978 - City 2016 GO Bond Proceeds Totals		Transactions Invoice 1	\$779.22
		Transactions	



Board of Public Works Claim Register

Invoice Date Range 04/27/24 - 05/10/24

Fund **986 - GO Bonds 2022**

Department **06 - Controller's Office**

Program **060000 - Main**

Account **54510 - Other Capital Outlays**

16 - Butler, Fairman & Seufert, INC

07-High Street Multiuse Path and Intersections-Feb 2024	BC 2022-063	05/10/2024	67,446.50
Account 54510 - Other Capital Outlays Totals	Invoice 1		<u>67,446.50</u>
Program 060000 - Main Totals	Transactions Invoice 1		<u>67,446.50</u>
Department 06 - Controller's Office Totals	Transactions Invoice 1		<u>67,446.50</u>
Fund 986 - GO Bonds 2022 Totals	Transactions Invoice 1		<u>67,446.50</u>
	Transactions		

Fund **987 - Econ Dev LIT Bonds of 2022**

Department **06 - Controller's Office**

Program **08FIR1 - Fire Station 1**

Account **54510 - Other Capital Outlays**

6985 - Martin Riley, INC

08-FS#1-Construction Administration-serv thru 3/31/24		05/10/2024	6,572.40
Account 54510 - Other Capital Outlays Totals	Invoice 1		<u>6,572.40</u>
Program 08FIR1 - Fire Station 1 Totals	Transactions Invoice 1		<u>6,572.40</u>
	Transactions		

Program **08FIR3 - Fire Station 3**

Account **54510 - Other Capital Outlays**

6985 - Martin Riley, INC

08-FS#3-Professional Serv-.Addition/Renovation-serv thru 3/31/24		05/10/2024	32,130.00
Account 54510 - Other Capital Outlays Totals	Invoice 1		<u>32,130.00</u>
Program 08FIR3 - Fire Station 3 Totals	Transactions Invoice 1		<u>32,130.00</u>
Department 06 - Controller's Office Totals	Transactions Invoice 2		<u>38,702.40</u>
Fund 987 - Econ Dev LIT Bonds of 2022 Totals	Transactions Invoice 2		<u>38,702.40</u>
	Transactions		



Board of Public Works Claim Register

Invoice Date Range 04/27/24 -
05/10/24

Grand Totals	Invoice 363	<u>\$1,643,685.09</u>
	Transactions	

REGISTER OF CLAIMS
Board of Public Works Claim Register

Date:	Type of Claim	FUND	Description	Bank Transfer	Amount
05/10/24	Claims				\$1,643,685.09
					<u>\$1,643,685.09</u>

ALLOWANCE OF CLAIMS

We have examined the claims listed on the foregoing register of claims, consisting of claims, and except for the claims not allowed as shown on the register, such claims are hereby allowed in the total amount of \$1,643,685.09

Dated this 6th day of May year of 2024.

 Kyla Cox Deckard, President

 Elizabeth Karon, Vice President

 James Roach, Secretary

I hereby certify that each of the above listed voucher(s) or bill(s) is (are) true and correct and I have audited same in accordance with IC 5-11-10-1.6.

Fiscal Office _____