

Board of Public Works Meeting

May 21, 2024



The City will offer virtual options, including CATS public access television (live and tape-delayed) and

Public comments and questions will be encouraged via Zoom or bloomington.in.gov rather than in person

The City is committed to providing equal access to information. However, despite our efforts, at times, portions of our board and commission packets are not accessible for some individuals. If you encounter difficulties accessing material in this packet, please contact April Rosenberger, Public Works Departmental Accessibility contact at april.rosenberger@bloomington.in.gov or 812.349.3411 and provide your name, contact information, and a link to or description of the document or web page you are having problems with.

AGENDA
BOARD OF PUBLIC WORKS
May 21, 2024

A Regular Meeting of the Board of Public Work will be held **Tuesday, May 21, 2024 at 5:30 p.m.** in the Council Chambers (RM# 115) of City Hall at the Showers Building, 401 N. Morton Street, Bloomington, Indiana and via Zoom by using the following link

<https://bloomington.zoom.us/j/86875775006?pwd=fZ2fcukQwbK9xo6CKKMTWxw7JYNqas.1>

Meeting ID: 868 7577 5006 Passcode: 236042

- I. MESSAGES FROM BOARD MEMBERS**
- II. PETITIONS AND REMONSTRANCES**
- III. CONSENT AGENDA**
 - 1. Resolution 2024-027; Renew Mobile Vendor, Doner Kebob**
 - 2. Resolution 2024-028; 4th & Rogers Block Party**
 - 3. Resolution 2024-029; Blue Ridge Neighborhood Food Truck Nights & Neighborhood Picnic**
 - 4. Addendum #3 to Preliminary Engineering Contract with WSP USA for Neighborhood Greenway Projects**
 - 5. Sidewalk Closure Request from Clark Concrete in the 100 block of N. Grant (May 22, 2024-May 26, 2024)**
 - 6. Request from CenterPoint Energy for Temporary Easement at 2120 S. Highland Ave**
 - 7. Request from CenterPoint Energy for Temporary Easement at 810 N. Woodlawn Ave**
 - 8. Renewal #1 with Cargill Salt**
 - 9. Approval of Payroll**
- IV. NEW BUSINESS**
 - 1. Resolution 2024-030 Public Need to Purchase Right of Way for the High Street Intersection Modernizations and Multiuse Path Project**
 - 2. Amendment #1 to existing LPA-Consulting Contract with Butler, Fairman & Seufert, Inc. for Preliminary Engineering Services for the High Street Intersection Modernizations and Multiuse Path Project**
 - 3. New LPA-Consulting Contract with Butler, Fairman & Seufert, Inc. for Right of Way Acquisition Services for the High Street Intersection Modernizations and Multiuse Path Project**
 - 4. Change Order #2 for Adams St Sidewalk Project**
 - 5. Request for Sidewalk and Road Closure Extensions from AEG**
- V. STAFF REPORTS & OTHER BUSINESS**
- VI. APPROVAL OF CLAIMS**
- VII. ADJOURNMENT**

The City is committed to providing equal access to information. However, despite our efforts, at times, portions of our board and commission packets are not accessible for some individuals. If you encounter difficulties accessing material in this packet, please contact April Rosenberger, Public Works Departmental Accessibility contact at april.rosenberger@bloomington.in.gov or 812.349.3411 and provide your name, contact information, and a link to or description of the document or web page you are having problems with.

The City offers virtual options, including CATS public access television (live and tape- delayed). Comments and questions will be encouraged via Zoom or bloomington.in.gov rather than in person.

Auxiliary aids for people with disabilities are available upon request with adequate notice. Please call 812.349.3411 or email public.works@bloomington.in.gov

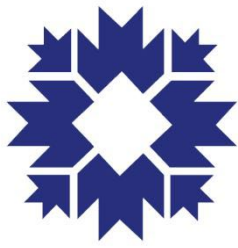

CITY OF BLOOMINGTON

ECONOMIC AND SUSTAINABLE DEVELOPMENT

Project/Event:	Mobile Vendor in Right of Way
PW Resolution No:	2024-027
Petitioner/Representative:	Ahmad Naderi, Owner of Doner Kebab, Inc
Staff Representative:	Susan Coates
Meeting Date:	05/21/2024

Doner Kebab, Inc, by its owner, Ahmad Naderi, has applied for a Mobile Vendor License to operate a food truck/trailer. An applicant wanting to operate in the right of way must obtain permission from the Board of Public Works before a license may be issued. The Department of Economic & Sustainable Development has reviewed the application and will confirm that all rules and regulations have been met prior to issuing a license.

The business will be selling food via a mobile kitchen food truck or trailer.

This application is for 1 year.

There had been complaints that his generator was too loud so he chose to replace despite test showing it was within the 70dB limit. Noise measurements were taken by an app following the directions listed on the ordinance and no further complaints have been received since the replacement.

Staff is supportive of the request.

2024

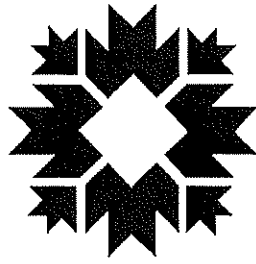

CITY OF BLOOMINGTON

ECONOMIC AND SUSTAINABLE DEVELOPMENT

Business License Cover Sheet

Business Name	Doner Kebab, Inc
License Type	Mobile Vendor License
Contact	Ahmad Naderi
Phone	812-219-1956
Email	donerkeb1@gmail.com
BPW Resolution No (if applicable)	2024-027
Issue Date of License	5/23/2024
Expiration Date of License	5/23/2025
Scanned?	<input checked="" type="checkbox"/>
Renewal Date for License	5/23/2025
Department Head	Jane Kupersmith
Record Destruction Date	5/23/2028
ESD Tracking No	N/A
Document Physical Filing Location	2-drawer file cabinet at ESD Admin's desk
Document Digital Filing Location	I:\common\Economic Development\BUSINESS\Business Licensing\Licenses\Mobile Vendor License\Businesses

2024
Doner Kebab.

Res. 2024-027

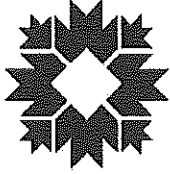

CITY OF BLOOMINGTON

MOBILE VENDOR LICENSE APPLICATION

City of Bloomington
Department of Economic and Sustainable Development
401 N. Morton St. Suite 150
Bloomington, Indiana 47404
812-349-3418

1. License Length and Fee Application

Length of License: 1 Year - \$350

pd 5/3/24
ck #1019.

2. Applicant Information

Name:	Ahmad N. Naderi		
Title/Position:	Owner		
Date of Birth:	09/10/70		
Address:	3335 John Hinkle Place		
City, State, Zip:	Bloomington IN 47408		
E-Mail Address:	donerkeb1@gmail.com		
Phone Number:	812-219-1956	Mobile Phone:	812-219-1956

3. Indiana Contact Information (For non-residents only)

If applicant is not a resident of Indiana, they must designate a resident to serve as a contact.

Name:			
Address:			
City, State, Zip:			
E-Mail Address:			
Phone Number:		Mobile Phone:	

Received in ESD

MAY 03 2024

5/3/24 - waiting on Res NO ✓
waiting on Fire Inspection ✓/vd 5/8/24

4. Company Information

Name of Employer:	Ahmad N. Wadasi			
Address of Employer:	3335 John Hinkle Place			
City, State, Zip:	Bloomington IN 47408			
Employment Start Date:		End Date (If known):		
Phone Number:	812-219-1956			
Website / Email:	doneskeb1@gmail.com			
Company is a:	<input type="checkbox"/> Limited Liability Corporation (LLC)	<input checked="" type="checkbox"/> Corporation	<input type="checkbox"/> Partnership	<input type="checkbox"/> Sole Proprietor <input type="checkbox"/> Other:

5. Company Officer Information

Provide the names and addresses of all principal officers, partners, trustees, owners or other persons with controlling interests in the company.

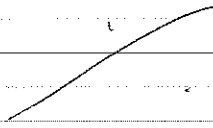
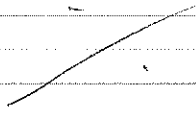
Name	Address
	

6. Company Incorporation Information (For Corporations and LLCs Only)

Date of incorporation or organization:	01/15/16
State of incorporation or organization:	Indiana
(If Not Indiana) Date qualified to transact business in state of Indiana:	

7. Description of product or service to be sold and any equipment to be used

Gyro / Döner Kebab, Fridges, Warmer, Sinks, Water Heater Gyro machine, water pump	
Planned hours of operation:	10:00 am — 8:00 pm
Place or places where you will conduct business (If private property, attach written permission from property owner):	Restaurant Depot
Scaled site plan showing the location of the proposed mobile food vendor unit and the properties' drives, parking access aisles, fire lanes, sidewalks and accessible routes.	Kirkwood, Switchyard Park Please Attach
Have you had a similar license, either from the City of Bloomington, or a different municipality, revoked?	Yes <input type="checkbox"/> No <input checked="" type="checkbox"/>
(If Yes) Provide details	

Received in ESD

MAY 03 2024

8. You are required to secure, attach, and submit the following:

<input checked="" type="checkbox"/>	A copy of the Indiana registration for the vehicle
<input checked="" type="checkbox"/>	Copy of a valid driver's license
<input checked="" type="checkbox"/>	Copy of an Indiana Driver's Record and/or equivalent of whatever State has issued the applicant his/her driver's license
<input checked="" type="checkbox"/>	Proof of an independent safety inspection of all vehicles to be used in the business (form included with app)
<input checked="" type="checkbox"/>	Proof of insurance in accordance with the limits described in Section 4.28.090 of the Bloomington Municipal Code: <ul style="list-style-type: none"> • Personal Injury: \$100,000.00 per occurrence and \$300,000 in the aggregate • Property Damage: \$25,000.00 per occurrence and \$50,000.00 in the aggregate
<input checked="" type="checkbox"/>	Release of liability wherein the Applicant agrees to indemnify and hold harmless the City of Bloomington for losses or expenses arising out of the operation of his/her business (included with application)
<input checked="" type="checkbox"/>	A copy of the business's registration with the Indiana Secretary of State.
<input checked="" type="checkbox"/>	A copy of the Employer ID number
<input checked="" type="checkbox"/>	A signed copy of the Prohibited Location Agreement (included with application)
<input checked="" type="checkbox"/>	A signed copy of the Standards of Conduct Agreement (included with application)
<input checked="" type="checkbox"/>	Fire inspection (if required)
<input checked="" type="checkbox"/>	Picture of truck or trailer
<input checked="" type="checkbox"/>	Copy of all applicable permits required by the Monroe County Health Department, including but not limited to a Food Service Establishment License or a Certified Food Handler License.

ETP.

For City Of Bloomington Use Only

Date Received: 5/3/24	Received By: [Signature]	Date Approved: 5/8/24	Approved By: [Signature]
--------------------------	-----------------------------	--------------------------	-----------------------------

✓ Waiting on copy of Veh. Registration.

Waiting on Reinstatement of Business
w/ secretary of state.
(in process) 5/15/24



Sign Out

Bureau of
Motor Vehicles



- my Driver Records
- View Your Driver Record
- Official Driver Record
- Pay Reinstatement Fees Online
- Renew Your License, Permit or ID Card
- Add MotorCycle Endorsement
- View Your Recent Driver Notices
- Track Your Recent Renewals
- Replace Your License, Permit or ID Card
- Schedule Driving Test
- View Renewal Date
- DL Self-Certify Driver Type
- Proceed to Checkout

my Driver Records
Welcome, AHMAD N NADERI!

**** NOTE:** The BMV only retains supporting documentation for a period of ten (10) years **

License type: DRIVERS

As of 03/19/2024 8:44 pm
IINT

License status: VALID

SR22: Not needed

Current points: 0

Endorsements: None

Pending Endorsements: None

Restrictions: B

Pending Restrictions: None

Suspension Information -- (* indicates active suspensions)

-- (** indicates closed/expired active suspensions stayed)

Susp ID	Type	Suspension Reason	Effective Date	Expiration Date	Mail Date	Address ID	Fee Due
5	Invalidation	VISION FAILURE TO COMPLY	04/25/2023	02/28/2024	02/24/2023		
3	Invalidation	VISION FAILURE TO COMPLY	06/07/2022	02/22/2023	04/08/2022		

Pending Suspension Information

No Pending Suspensions were found.

Disqualification Information -- (* indicates active disqualifications)

No Disqualifications were found.

Pending Disqualification Information

No Pending Disqualifications were found.

Out of State Withdrawal Information

No OOS Withdrawals were found.

Convictions -- (* indicates active points)

Disposition Date	Pts	Offense Description	Offense Date	Court / Case Number	Susp IDs	Disq IDs	CMV	Hazmat
12/03/2015	0	SEAT BELT VIOLATION	10/23/2015	MONROE CIRCUIT #4 / 53C041510IF004718			No	No
08/13/2008	0	SEAT BELT VIOLATION	07/02/2008	MONROE CIRCUIT #2 / 53C0208071F09478			No	No
04/02/2008	0	SEAT BELT VIOLATION	03/13/2008	MONROE CIRCUIT #2 / 53C0208031F04312			No	No

Click to Verify - This site chose
VeriSign SSL for secure e-commerce
and confidential communications.
ABOUT SSL CERTIFICATES

10/29/2007	0	SEAT BELT VIOLATION	09/20/2007	MONROE CIRCUIT #2 / 53C020709IF17694	No	No
08/18/2004	0	SEAT BELT VIOLATION	08/12/2004	MONROE CIRCUIT #2 / 53C020408IF08314	No	No

Mailing Addresses

ID	Effective Date	Street Address	City	State	ZIP Code
11	04/09/2022	3335 E JOHN HINKLE PL	BLOOMINGTON	IN	47408-2659
10	03/22/2022	3335 E JOHN HINKLE PL	BLOOMINGTON	IN	47408-2659
8	01/08/2020	3800 E MCCRACKEN WAY APT 8	BLOOMINGTON	IN	47408-2760
7	03/17/2018	3800 E MCCRACKEN WAY APT 8	BLOOMINGTON	IN	47408-2760
5	07/24/2012	3911 E STONEGATE CT	BLOOMINGTON	IN	47401-9801
4	07/15/2012	11557 CAVALIER LANDING CT	FAIRFAX	VA	22030-8554
3	08/12/2006	3911 STONEGATE CT	BLOOMINGTON	IN	47401-9801
2	05/10/2002	802 MARIA CT	BLOOMINGTON	IN	47401

Legal Addresses

ID	Effective Date	Street Address	City	State	ZIP Code
11	04/09/2022	3335 E JOHN HINKLE PL	BLOOMINGTON	IN	47408-2659
9	03/22/2022	3911 E STONEGATE CT	BLOOMINGTON	IN	47401-9801
6	03/17/2018	3911 E STONEGATE CT	BLOOMINGTON	IN	47401-9801
5	07/24/2012	3911 E STONEGATE CT	BLOOMINGTON	IN	47401-9801
3	08/12/2006	3911 STONEGATE CT	BLOOMINGTON	IN	47401-9801
1	06/03/2002	802 MARIA CT	BLOOMINGTON	IN	47401

Credential Issuance

Interim Credential Issue Date: 2/28/2024, Expiration Date: 3/29/2024, Reason: AMEND DL W/O CARD, IN-STATE, Control #: 23454298

Issue Date: 02/28/2024, Amend License, DRIVERS, Endorsements: None, Restrictions: B, Expiration Date: 09/10/2028

Interim Credential Issue Date: 4/9/2022, Expiration Date: 5/9/2022, Reason: RENEWAL DL W/O CARD, IN-STATE, Control #: 19944529

Issue Date: 04/09/2022, Renew License, DRIVERS, Endorsements: None, Restrictions: None, Expiration Date: 09/10/2028

Issue Date: 03/10/2016, Renew License, DRIVERS, Endorsements: None, Restrictions: None, Expiration Date: 04/09/2022

Issue Date: 07/24/2012, Renew License, DRIVERS (4 Year) NonProb, Endorsements: None, Restrictions: None, Expiration Date: 03/10/2016

Credential Issuance

Interim Credential Issue Date: 2/28/2024, Expiration Date: 3/29/2024, Reason: AMEND DL W/O CARD, IN-STATE, Control #: 23454298

Issue Date: 02/28/2024, Amend License, DRIVERS, Endorsements: None, Restrictions: B, Expiration Date: 09/10/2028

Interim Credential Issue Date: 4/9/2022, Expiration Date: 5/9/2022, Reason: RENEWAL DL W/O CARD, IN-STATE, Control #: 19944529

Issue Date: 04/09/2022, Renew License, DRIVERS, Endorsements: None, Restrictions: None, Expiration Date: 09/10/2028

Issue Date: 03/10/2016, Renew License, DRIVERS, Endorsements: None, Restrictions: None, Expiration Date: 04/09/2022

Issue Date: 07/24/2012, Renew License, DRIVERS (4 Year) NonProb, Endorsements: None, Restrictions: None, Expiration Date: 03/10/2016

Issue Date: 08/12/2006, Renew License, DRIVERS, Endorsements: None, Restrictions: None, Expiration Date: 09/10/2012

Issue Date: 05/10/2002, Issue ID Card, REGULAR ID CARD, Endorsements: None, Restrictions: None, Expiration Date: 05/31/2006

Issue Date: 06/03/2002, Renew License, DRIVERS, Endorsements: None, Restrictions: None, Expiration Date: 09/10/2006

Remarks

No Remarks were found.

* End of Driver Record *

How to Read an Indiana Bureau of Motor Vehicles (BMV) Official Driver Record

(This legend applies to driver records printed on or after 06/30/2016.)

Personal Information

* First, middle, last name, suffix (if included)

* Street address

Note: If the driver's address has changed and, therefore, is different than the address listed in the records of the BMV, Indiana law requires the driver to update their address with the BMV.

* Birth date & Gender

Driver's License Information

* License Number - unique BMV identification number for each resident with a BMV driver file - (this information is provided only if requestor is authorized to receive)

* License Type - type of base license last issued: "Unlicensed" denotes the individual is

CITY OF BLOOMINGTON

MOBILE VENDOR INSPECTION CHECK SHEET

COMPANY PERFORMING INSPECTION Meineke
INSPECTOR'S NAME Steve Bryant INSPECTOR'S PHONE # 812-339-7855
DATE OF INSPECTION 4-5-2023 exp 4/2025
TAXICAB COMPANY _____
VEHICLE YEAR 1985 MAKE GMC MODEL 3500
VIN 1GTHP32M0F3506516

	PASS	FAIL	COMMENTS
LIGHTS (Front & Rear)	X		
FLASHERS	X		
REFLECTORS	X		
HORN	X		
WINDSHIELD WIPERS	X		
MIRRORS	X		
SEATBELTS	X		
BUMPER HEIGHT	X		
ALL WINDOWS	X		
MUFFLER	X		
TIRES	X		
BRAKES	X		
DOORS	X		
GENERAL CONDITION OF VEHICLE	X		

Attach this completed Inspection Sheet with your permit or renewal application
and remit to:
City of Bloomington
Department of Economic and Sustainable Development
401 N. Morton St.
Bloomington, Indiana 47404
812-349-3419

Additional Comments by Inspector: _____

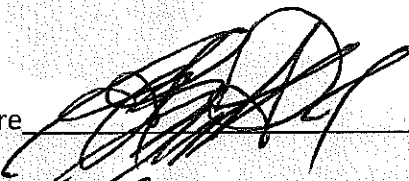
Inspector Signature  _____
Date: 4.5.2023 _____

**Attach this completed Inspection Sheet with your permit or renewal application
and remit to:
City of Bloomington
Department of Economic and Sustainable Development
401 N. Morton St.
Bloomington, Indiana 47404
812-349-3419**



SHELTER INSURANCE COMPANIES

AUTOMOBILE
EVIDENCE OF INSURANCE
AS OF 03/21/2022

NAME AND ADDRESS OF NAMED INSURED:
NADERI, AHMAD NAWEED
3335 E JOHN HINKLE PL
BLOOMINGTON, IN 47408-2659

AGENT:
HAZEN INSURANCE AGENCY LLC
804 S AUTO MALL RD
BLOOMINGTON, IN 47401-5430
(812) 334-1413
AGENT NUMBER 13-D743-51

Policy Number: 13-1-9383969-7

Effective Date: 03/21/2022, 08:09 AM Central Time

Expiration Date: 09/21/2022, 12:01 AM Central Time

This policy will continue to renew as long as we offer to renew it and you pay the required premium by the due date.

THE DESCRIBED AUTOMOBILE IS A 2008 HONDA ODYSSEY EX-L W/RES
VEHICLE IDENTIFICATION # 5FNRL38788B062521

The limit of the company's liability is stated in the policy and applies as follows:

COVERAGE	A BODILY INJURY		B PROPERTY DAMAGE	C MEDICAL PAYMENTS	D ACCIDENTAL DEATH	E UNINSURED MOTORISTS		F COLLISION	G COMPREHENSIVE	J REIMBURSEMENT FOR EMERGENCY ROAD SERVICE
	EACH PERSON	EACH ACCIDENT	EACH ACCIDENT	EACH PERSON	EACH PERSON	EACH PERSON	EACH ACCIDENT	DEDUCTIBLE	DEDUCTIBLE	EACH DISABLEMENT
LIMIT	\$50,000	\$100,000	\$50,000	\$2000		\$50,000	\$100,000			
PREMIUM	X			X		X				

DISCOUNTS REFLECTED IN THE PREMIUM: Multi-Car, Passive Restraint, New Safe Driver, Pay in Full

PREMIUM \$171.32

ADDITIONAL LISTED INSURED: NADERI, AHMAD NAWEED

THE FOLLOWING ENDORSEMENTS ARE A PART OF THIS POLICY AND ARE ATTACHED:

- A-120.4-A Amendatory Endorsement - Indiana
- A-150-A New Vehicle Replacement Coverage
- A-151.2-A Roadside Assistance - Premium: 0.00
- A-630.8-A Uninsured Motorist Property Damage Endorsement (No Deductible)
- S-18-S Mutual Policy Notification

RATE CLASS	DIN	TERRITORY	017	TERM	06 MONTHS
COST SYMBOL	030	PACKAGE CODE	2	TIER	2000

Secretary

President and CEO

A-622-A



Named Insured

NADERI, AHMAD NAWEED
3335 E JOHN HINKLE PL
BLOOMINGTON, IN 47408-2659

Agent

HAZEN INSURANCE AGENCY LLC
(812) 334-1413
13-D743-51

Policy Number: 13-1-9383969-7 **Effective Date: 03/21/2022, 08:09 AM Central Time**
Expiration Date: 09/21/2022, 12:01 AM Central Time

SECTION 3: VEHICLE INFORMATION

VEHICLE	MAKE	MODEL	VEHICLE ID#	Use/Miles	Annual Miles
2008	HONDA	ODYSSEY EX-L W/RES	5FNRL38788B062521	PERSONAL/0	4000

LOSS PAYEE, LEND HOLDER OR ADDITIONAL INTEREST INFORMATION

Name	Address	Type
------	---------	------



Named Insured

NADERI, AHMAD NAWEED
3335 E JOHN HINKLE PL
BLOOMINGTON, IN 47408-2659

Agent

HAZEN INSURANCE AGENCY LLC
(812) 334-1413
13-D743-51

Policy Number: 13-1-9383969-7

Effective Date: 03/21/2022, 08:09 AM Central Time

Expiration Date: 09/21/2022, 12:01 AM Central Time

SECTION 1: COVERAGES YOU REQUESTED

ON 2008 HONDA ODYSSEY EX-L W/RES

VIN: 5FNRL38788B062521

COVERAGE	LIMIT	DEDUCTIBLE	PREMIUM
Bodily Injury/Property Damage	50/100/50		126.37
Medical Payments	2000		11.98
Uninsured Motorist	50/100		32.97
Roadside Assistance	100		0.00

ENDORSEMENTS: (ENDORSEMENT PREMIUMS ARE INCLUDED ABOVE)

Amendatory Endorsement - Indiana			
New Vehicle Replacement Coverage			
Roadside Assistance	100		
Uninsured Motorist Property Damage Endorsement (No Deductible)	25		\$12.67
Mutual Policy Notification			

INCLUDED DISCOUNTS:

- Multi-Car
- Passive Restraint
- New Safe Driver
- Pay in Full

TAX/SURCHARGE	0.00
TOTAL PREMIUM FOR REQUESTED TERM	171.32



AUTO | HOME | LIFE

Named Insured

NADERI, AHMAD NAWEED
3335 E JOHN HINKLE PL
BLOOMINGTON, IN 47408-2659

Agent

HAZEN INSURANCE AGENCY LLC
(812) 334-1413
13-D743-51

Policy Number: 13-1-9383969-7 **Effective Date: 03/21/2022, 08:09 AM Central Time**
Expiration Date: 09/21/2022, 12:01 AM Central Time

SECTION 2: DRIVER INFORMATION

LISTED BELOW ARE ALL DRIVERS OF MY:

2008 HONDA ODYSSEY EX-L W/RES

DRIVER INFORMATION

Driver #	Name	Date Of Birth	Gender	Marital Status	Relationship	SR-22	Excluded	License Number
1.	NADERI, AHMAD NAWEED	09/10/1970	M	Divorced	Named on Title	NO	NO	0130894620

ACCIDENTS AND VIOLATIONS

Driver #	Date	Accident	Driver #	Date	Violation
----------	------	----------	----------	------	-----------

REPRESENTATIONS

1. Does any driver or member of the household currently have any license or permit to drive suspended, revoked, or in any such status? NO
2. Is there any vehicle in the household that has been driven without insurance in the last 90 days? NO



SHELTER INSURANCE COMPANIES

1817 WEST BROADWAY, COLUMBIA, MISSOURI 65218-0001

ShelterInsurance.com

Phone:1-800-SHELTER

Federal Tax ID: 43-0613000

Payor Name / Cardholder					Payment Amount
NADERI, AHMAD N / NADERI, AHMAD N					294.58
Type	Number	Amount	Transaction Number	Agent Number	Date Payment Received
Card	MC *2368	\$294.58	14740	13-D743-51	03/21/2022

Payment Detail				
Policy Number		Insured Name	Risk Description	Payment Amount
13-1-9383969-7	NB	NADERI, AHMAD NAWOOD	2008 HONDA ODYSSEY EX-L W/RES	171.32
13-1-9383969-1	PC	NADERI, AHMAD NAWOOD	1995 TOYO CAMRY LE 4DR V6	123.26
Total Payment Received:				294.58

For policy details or payment questions, please contact your agent or call 1-800-SHELTER (1-800-743-5837).

M-1408.2-M

Receipt

Kerry Thomson
Mayor
CITY OF BLOOMINGTON
401 N. Morton St Suite 130
P.O. Box 100
Bloomington, Indiana 47402

DEPARTMENT OF ECONOMIC
& SUSTAINABLE DEVELOPMENT
p. 812.349.3418
f. 812.349.3520

RELEASE, HOLD-HARMLESS AND INDEMNIFICATION AGREEMENT

The undersigned, in consideration for the issuance of a license by the City of Bloomington Controller, agrees to the following:

1. The undersigned, in exchange for the issuance of a license by the City of Bloomington Controller, agrees to release, hold harmless, and forever indemnify the City of Bloomington and any and all City employees, officers, and agents from any claim or claims which may arise out of any incident connected with or in any way related to his/her issuance of a license by the City of Bloomington or his/her operation of a business which was licensed by the City of Bloomington. This includes claims for personal injury, death, property damage, and/or any other type of harm or injury.
2. The undersigned shall, and hereby does, indemnify, defend, and hold harmless the City of Bloomington and any and all City employees, officers, and agents from and against any and all actions, costs, claims, suits, losses, expenses or damages, including but not limited to attorneys' fees and court costs, arising out of the undersigned's operation of a business which has been licensed by the City of Bloomington.
3. The undersigned understands this release binds him/herself, his/her spouse, and all heirs, executors, partners, co-owners and administrators of those individuals.

The undersigned acknowledges that he/she has read this release and understands all of its terms. The undersigned signs this release voluntarily and with full knowledge of its significance.

AHMAD NADERI
Name, Printed

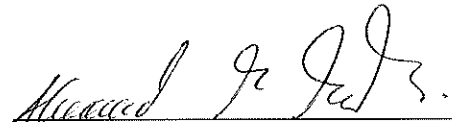
Signature

5/2/24
Date Release Signed



State Form 48099 (RS/7-17)
Approved by State Board of
Accounts 2017

INDIANA CERTIFICATE OF VEHICLE REGISTRATION



INSTRUCTIONS FOR APPLYING PLATE DECALS:

1. Verify plate number and decal match.
2. Do not attempt to apply decal if temperature is below -10 degrees Fahrenheit.
3. Clean and dry plate before affixing new decal.
4. Remove decal by bending corner of card under decal along dotted line.

PEEL HERE

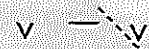

5. Next, lift up corner of decal where card was creased.
6. Decal is fragile, peel decal off slowly.
7. Place decal in the upper right corner of your license plate.
8. Rub or press firmly around edges of decal after applying.

CLASS 5	AGE 38	ISSUE DATE 08/08/23	PUR DATE 08/28/15	COUNTY MONROE	TP R	PL YR 2023	PLATE XKF242	PL TP SP	WEIGHT	PR YR 22	LS N	TYPE SP	PRIOR YR PL XKF242
EXPIRATION DATE 08/21/24		MUNICIPALITY Bloomington			VEHICLE YEAR 1985	MAKE GMC	MODEL VAL	VEHICLE IDENTIFICATION NUMBER 1GTHP32MDF3506516		TYPE VA	COLOR WHI		
CURRENT YEAR TAX	VEH EX TAX 12.00	EX CREDIT 0.00	DAV CREDIT 0.00	NET EX TAX 12.00	CO. WHEEL/EX TAX 25.00	MUN. WHEEL/EX TAX 0.00	STATE REG FEE 36.35	ADMIN FEE 0.00	TOTAL 73.35				
PRIOR YEAR TAX	VEH EX TAX 0.00	EX CREDIT 0.00	DAV CREDIT 0.00	NET EX TAX 0.00	CO. WHEEL/EX TAX 0.00	MUN. WHEEL/EX TAX 0.00	STATE REG FEE 0.00	ADMIN FEE 0.00	TOTAL 0.00				
REGISTRATION LICENSE TYPE IN GOD WE TRUST NEW FORMAT HIGH DIGIT PASSENGER													



Legal Address
3335 E JOHN HINKLE PL
BLOOMINGTON INDIANA 47408-2659

AHMAD N NADERI
3335 E JOHN HINKLE PL
BLOOMINGTON IN 47408-2659



Kerry Thomson
Mayor
CITY OF BLOOMINGTON
401 N. Morton St Suite 130
P.O. Box 100
Bloomington, Indiana 47402

DEPARTMENT OF ECONOMIC
& SUSTAINABLE DEVELOPMENT
p. 812.349.3418
f. 812.349.3520

Prohibited Location Agreement

Bloomington Municipal Code Section 4.28.140 prohibits Mobile Vendor Units from operating in certain locations. This Agreement provides for all of the prohibited locations. Two maps are also attached to this Agreement. All signatories to this Agreement are required to review not only this Agreement, but also the attached maps prior to signing this Agreement.

As a licensed Mobile Vendor Unit, I understand and agree that I cannot and will not operate my mobile vendor unit in a manner that would violate any of the below-listed location restrictions:

- No mobile food vendor unit shall locate in any parking lot, parking space, or parking facility owned, leased or managed by the City of Bloomington unless approval has been given by the City's Board of Public Works.
- No mobile food vendor unit shall operate within fifty feet of any facade of a ground level establishment that also sells food or beverages, or operate within fifty feet of the perimeter of such an establishment's outdoor seating area, regardless of whether or not the mobile food vendor unit is currently conducting business. The distance restriction only applies from one hour before the opening time to an hour after the closing time posted by a ground level establishment on the facade of its building.
- No mobile food vendor unit shall locate in an alleyway.
- Mobile food vendor units shall be located a reasonable distance from all posted bus stops, crosswalks, driveways, alleyways, right-of-way lines of two or more intersecting streets and building entrances or walk-up windows.
- Mobile food vendor units shall only be located on private property if the private property owner has provided both the business operator and the City written permission for the mobile food vendor unit to locate on said property.
- No mobile food vendor unit shall locate within a one block radius of a Special Event unless prior approval has been granted by either the operator of the Special Event or the City's Board of Public Works.
- No mobile food vendor unit shall park on City property in violation of any City parking regulation, restriction, or ordinance. For example, if parking at one, or multiple, parking meters, the operator of the mobile food vendor unit shall feed all relevant parking meters with the required monetary amount.
- No mobile food vendor unit shall be located in a manner which would significantly impede or prevent the use of any City of Bloomington property, or which would endanger the safety or property of the public.
- No mobile food vendor unit shall be located within fifteen feet of any fire hydrant.

- No mobile food vendor shall locate within any zoning district except the following: Commercial General; Commercial Arterial; Commercial Downtown; Industrial General; Business Park; and Institutional.
- No mobile food vendor operating on private property shall displace required parking or landscaping nor block any drives, parking access aisles, fire lanes, sidewalks, or accessible routes required for the private parking by the City's zoning code.
- No mobile food vendor unit shall be located more than one foot away from the curb of the street on which it is parked.
- No mobile food vendor unit shall park near an intersection and in a manner that blocks the line-of-sight of drivers using adjacent roadways.

I, the undersigned, understand that if I locate my mobile vendor unit in any of the above-described prohibited locations or manner that I subject myself to fines and possible revocation of my Mobile Vendor Unit License, as so described in Chapter 4.28 of the Bloomington Municipal Code.

Vendor:

Name: Doner Kebab

Signature: Alcegaad S. Isji

Date: 5/2/24

Kerry Thomson
Mayor
CITY OF BLOOMINGTON
401 N. Morton St Suite 130
P.O. Box 100
Bloomington, Indiana 47402

DEPARTMENT OF ECONOMIC
& SUSTAINABLE DEVELOPMENT
p. 812.349.3418
f. 812.349.3520

Standard of Conduct Agreement

Bloomington Municipal Code Section 4.28.160 provides Standards of Conduct for all Mobile Vendor Units. This Agreement provides a list of said Standards of Conduct. All signatories to this Agreement are required to review this Agreement prior to signing this Agreement.

As a licensed Mobile Vendor Unit, I understand and agree that I cannot and will not conduct business in a manner that would violate any of the Standards of Conduct noted below:

- Mobile food vendor unit operators shall conduct themselves at all times in an orderly and lawful manner, and shall not make, or cause to be made, any unreasonable noise of such volume as to be in violation of the City of Bloomington Noise Ordinance as stated in Title 14 of the Bloomington Municipal Code
- A device may not be used which would amplify sounds nor may attention be drawn to the mobile food vendor unit by an aural means or a light-producing device (examples of such devices may include, but are not meant to be limited to the following: bull horns and strobe lights
- No mobile food vendor unit may be permanently or temporarily affixed to any object, including but not limited to buildings, trees, telephone poles, streetlight poles, traffic signal poles or fire hydrants
- No mobile food vendor unit may be used to advertise any product which is not authorized to be sold from that unit
- Each mobile food vendor unit shall be limited to one sandwich board sign that meets the provisions of Section 20.05.086 of the Bloomington Municipal Code regardless of the zoning district in which it locates, provided a sign permit is obtained from the City's Planning and Transportation Department
- No mobile food vendor unit may make use of any public or private electrical outlet while in operation
- Each mobile food vendor unit shall protect against littering and shall have both an adequate trash receptacle and a separate receptacle for recyclable materials:
 - The trash and recyclable receptacles shall be emptied sufficiently often to allow disposal of litter and waste by the public at any time;
 - The trash and recyclable receptacles on the mobile food vendor unit shall not be emptied into trash or recyclable receptacles owned by the City of Bloomington;
 - Liquid from the mobile food vendor unit shall not be discharged on or in a City sewer or drain or elsewhere on City property, nor on private property without the express written consent of the owner thereof;

- Before leaving any location each mobile food vendor unit shall first pick up, remove and dispose of all trash, refuse and/or recyclable materials, including products spilled on the ground within twenty feet of the mobile food vendor unit.
- No mobile food vendor unit shall expose any pedestrian to any undue safety or health hazards nor shall it be maintained so as to create a public nuisance
- Each mobile food vendor unit shall be maintained free and clear of dirt, and finishes shall not be chipped, faded or unduly marred
- Foods or beverages which present a substantial likelihood that liquid matter or particles will drop to the street or sidewalk during the process of carrying or consuming the food or beverage shall be sold in proper containers so as to avoid falling to the street or sidewalk
- Mobile food vendor units which utilize a grill or device that may result in a spark, flame or fire shall adhere to the following additional standards:
 - Be placed approximately 20 feet from a building or structure;
 - Provide a barrier between the grill or device and the general public;
 - The spark, flame or fire shall not exceed 12 inches in height;
 - A fire extinguisher shall be within reaching distance of the mobile food vendor unit operator at all times;
- Mobile food vendor unit operators shall be required to obey the commands of law enforcement officers or fire officials with respect to activity carried out inside of the City's jurisdictional limits, including, where possible, the removal of the mobile food vendor unit and cessation of such sales
- No mobile food vendor unit shall ever be left unattended
- Mobile food vendor units shall not be stored, parked or left overnight on any City property
- All mobile food vendor units which are food service establishments as defined by Title 10.17 of the Bloomington Municipal Code shall install an approved grease interceptor or grease trap. Foods, oils and greases shall never be discharged into the City's sewer or storm drains
- All mobile food vendor unit operators are required to collect and pay all applicable and appropriate sales taxes
- No mobile food vendor shall provide customer seating unless approval has been provided by the City's Board of Public Works and the City's Planning and Transportation Department
- All mobile food vendors shall comply with the lighting standards found in Chapter 20.05 of the Bloomington Municipal Code
- All mobile food vendors shall comply with the vision clearance standards found in Chapter 20.05 of the Bloomington Municipal Code
- No mobile food vendor shall have a drive-thru
- The decibels of any generator(s) associated with a mobile food vendor unit shall not exceed "70dBA".
 - Such noise measurement shall be made at a height of at least four (4) feet above the ground and at a point approximately twenty-five (25) feet away from where the

noise is being emitted on a sound level meter operated on the "A" weighting network (scale).

- No person other than the operators shall be within twenty-five (25) feet of the sound level meter during the sample period.
- Sound measurements shall be conducted at that time of day or night when the relevant noise source is emitting sound.
- The sound level measurement shall be determined as follows:
 - Calibrate the sound level meter within one (1) hour before use.
 - Set the sound level meter on the "A" weighted network at slow response.
 - Set the omnidirectional microphone in an approximately seventy degree position in a location which complies with subsections (1) and (2) herein. The operator of the sound level meter shall face the noise source and record the meter's instantaneous response.
 - Recalibrate the sound level meter after use.
- It shall be unlawful for any person to interfere, through the use of sound or otherwise, with the taking of sound level measurement.

I, the undersigned, understand that if I conduct business in violation of any the above described standards of conduct that I subject myself to fines and possible revocation of my Mobile Vendor Unit License, as so described in Chapter 4.28 of the Bloomington Municipal Code.

Vendor:

Name: Döner Kebab

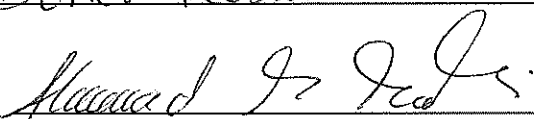
Signature: 

Date: 5/2/24

Mobile Food Service Establishment License

Monroe County Health Department

This is to certify that:

Doner Kebob

Ahmad Naderi

301 E Third St

Bloomington, IN 47401

Having complied with the rules and regulations of the Monroe County Health Department as authorized by the Indiana Administrative Code and the Board of Commissioners of Monroe County, Indiana, is hereby authorized to operate a Food Service Establishment at the above location for the calendar year.



Issued:

1/4/2024

2024

By

Monroe County Health Officer

NON-NEGOTIABLE AND NOT TRANSFERABLE

PERMIT EXPIRES FEBRUARY 28, 2025



Bloomington Fire Department

PO Box 100
Bloomington IN 47402
812-332-9763

Mayor Kerry Thomson
Roger Kerr

Interim Fire Chief

Temporary Food Vendor

Fire Permit

Permit Number	Effective Date Range	Expiration Date
BFD-2024-0000071	05/06/2024 - 05/06/2025	05/06/2025

Business Name

Doner Kebab

Billing Address

3335 E JOHN HINKLE PL DONER KEBAB 3335 E
JOHN HINKLE PL, BLOOMINGTON, IN, 47408

This permit is to certify that the named establishment has met the minimum standards of the Indiana Fire Code at the time of inspection. This is a **Fire Permit only** and does not indicate approval from any other agency or authority. Inspection and approval from the **State Health Department** is required and the final permit will be issued by the **City of Bloomington Economic and Sustainable Department**.

Permit Contact

Ahmed Naderi
Business Owner
812-219-1956
donerkeb1@gmail.com

Received in ESD

MAY 08 2024

Permit Signatures

Inspector Permit Signature

Jeff Yutmeyer

Deputy Fire Marshal

812-360-3507

Jeff.yutmeyer@bloomington.in.gov



City of Bloomington Fire Department

PO Box 100
Bloomington Indiana 47402
812-332-9763

Mayor Kerry Thomson

Fire Chief Roger Kerr

Current Date
05/06/2024

Inspected by
Jeff Yutmeyer

Next Inspection Date
05/02/2025

Inspection Number
BFD-2024-0001794

Business Name	Address	City	State	Zip
Doner Kebab	3335 E JOHN HINKLE PL	BLOOMINGTON	IN	47408
	Suite Doner Kebab 3335 E John Hinkle PL			

Fire Inspection Results

No fire code violations found.
Thank You

On 05/06/2024 the Doner Kebab was inspected by Bloomington Fire Department and no deficiencies were found.

Inspection Signatures

Occupancy Contact Signature

Unable to sign:

Not Present when report completed

Inspector Signature

Ahmed Naderi
Business Owner
812-219-1956
donerkeb1@gmail.com

Jeff Yutmeyer
Deputy Fire Marshal
812-360-3507

Received in ESD jeff.yutmeyer@bloomington.in.gov

MAY 08 2024





PAYMENT DATE
05/06/2024
COLLECTION STATION
06 Controller
RECEIVED FROM
AHMAD N NADERI / DONER
KABOB

City of Bloomington
401 N. Morton Street
Bloomington, IN 47404

BATCH NO.
2024-05003972
RECEIPT NO.
2024-00073364
CASHIER
Amy Silkworth

DESCRIPTION
1 YEAR MOBILE VENDOR LICENSE

PAYMENT CODE	RECEIPT DESCRIPTION	TRANSACTION AMOUNT																														
04-101-0000-1020	101 Econ Dev Permits	\$350.00																														
Payments:	<table border="1"> <thead> <tr> <th>Type</th> <th>Detail</th> <th>Amount</th> </tr> </thead> <tbody> <tr> <td>Check</td> <td>1019</td> <td>\$350.00</td> </tr> <tr> <td colspan="2">Total Cash</td> <td>\$0.00</td> </tr> <tr> <td colspan="2">Total Check</td> <td>\$350.00</td> </tr> <tr> <td colspan="2">Total Charge</td> <td>\$0.00</td> </tr> <tr> <td colspan="2">Total Wire</td> <td>\$0.00</td> </tr> <tr> <td colspan="2">Total Other</td> <td>\$0.00</td> </tr> <tr> <td colspan="2">Total Remitted</td> <td>\$350.00</td> </tr> <tr> <td colspan="2">Change</td> <td>\$0.00</td> </tr> <tr> <td colspan="2">Total Received</td> <td>\$350.00</td> </tr> </tbody> </table>	Type	Detail	Amount	Check	1019	\$350.00	Total Cash		\$0.00	Total Check		\$350.00	Total Charge		\$0.00	Total Wire		\$0.00	Total Other		\$0.00	Total Remitted		\$350.00	Change		\$0.00	Total Received		\$350.00	
Type	Detail	Amount																														
Check	1019	\$350.00																														
Total Cash		\$0.00																														
Total Check		\$350.00																														
Total Charge		\$0.00																														
Total Wire		\$0.00																														
Total Other		\$0.00																														
Total Remitted		\$350.00																														
Change		\$0.00																														
Total Received		\$350.00																														
Total Amount:		\$350.00																														
Customer Copy																																

BUSINESS INFORMATION
DIEGO MORALES
INDIANA SECRETARY OF STATE
05/15/2024 10:15 AM

Business Details

Business Name: **DONER KEBAB INC** Business ID: **201611041165667**
Entity Type: **Domestic For-Profit Corporation** Business Status: **Admin Dissolved**
Creation Date: **11/04/2016** Inactive Date: **06/05/2021**
Principal Office Address: **3800 E McCracken Way, Apt 8,
Bloomington, IN, 47408, USA** Expiration Date: **Perpetual**
Jurisdiction of Formation: **Indiana** Business Entity Report Due
Date: **11/30/2020**
Years Due: **2020/2021, 2022/2023**

Governing Person Information

Title	Name	Address
President	Ahmad Naderi	3800 E McCracken Way, Apt 8, Bloomington, IN, 47408, USA

Incorporators Information

Name	Title	Address
Ahmad Naderi	Incorporator	3911 E Stonegate Ct, Bloomington, IN, 47401, USA

Registered Agent Information

Type: **Individual**
Name: **Ahmad Naderi**
Address: **3800 E , Apt 8, Bloomington, IN, 47408, USA**

Date incorporated: 11/4/2016

*Date Dissolved
by Admin: 6/5/2021*

RESOLUTION 2024-027
CITY OF BLOOMINGTON
BOARD OF PUBLIC WORKS
Mobile Vendor in Public Right of Way
Doner Kebab, Inc

WHEREAS, the Board of Public Works is empowered by Indiana Code § 36-9-6-2 to supervise the streets, alleys, sewers, public grounds, and other property of the City of Bloomington (“City”);

WHEREAS, Doner Kebab, Inc (“Vendor”), is seeking a Mobile Vendor License under Bloomington Municipal Code 4.28;

WHEREAS, the issuance of a Mobile Vendor License under Bloomington Municipal Code 4.28 requires Vendor to submit documentation to the City—set forth at Bloomington Municipal Code 4.28.050—including an independent safety inspection, an open burn permit issued by the City of Bloomington Fire Department, and all applicable permits required by the Monroe County Health Department;

WHEREAS, Vendor has agreed to the Standards of Conduct set forth in Bloomington Municipal Code 4.28.160 and signed the Release, Hold-Harmless, and Indemnification Agreement as required by Bloomington Municipal Code 4.28.090;

WHEREAS, Vendor desires to be able to use “City property” as defined in Bloomington Municipal Code 4.28.010, which includes public on-street parking, on a temporary and transient basis for the purpose of selling food via a mobile kitchen food truck or trailer; and

WHEREAS, under the Bloomington Municipal Code, approval to use public on-street parking and sidewalks is provided by the Board of Public Works via resolution;

NOW, THEREFORE, BE IT RESOLVED BY THE BOARD OF PUBLIC WORKS THAT:

1. Vendor has permission to use on-street public parking and sidewalks, on a temporary and transient basis, for the purposes of selling food via a mobile kitchen food truck or trailer for 1 year beginning 5/23/2024, and ending on 5/23/2025.

2. For the avoidance of doubt, this Resolution is not the Business License referenced by Chapter 4.28 of the Bloomington Municipal Code. Thus, Vendor must ensure that all necessary documentation has been submitted to the City of Bloomington Controller and that the Business License has been issued by the City of Bloomington Controller before utilizing the permission to use on-street public parking and sidewalks granted in the paragraph above. Operating a mobile vendor without a business license is a violation of Bloomington Municipal Code 4.28.180(a)(1), and would subject Vendor to a fine of \$2,500 for the first offense.

3. For the avoidance of doubt, the following conditions—which in some instances may mirror those that exist under Title 4.28 of the Bloomington Municipal Code—attach to this approval:

- a. Vendor agrees to maintain a clear five-foot path for pedestrians on the sidewalk at all times.
- b. Vendor will have obtained a valid Mobile Vendor license issued by the City of Bloomington Controller prior to operation on City property, and will maintain a valid Mobile Vendor license throughout the term of Vendor’s operation on City property.
- c. Vendor may locate his business in a public parking space within a reasonable time, no more than one hour, before the vendor begins selling food to persons. Vendor must still comply with all other restrictions regarding its location in a public parking space.

RESOLUTION 2024-027

- d. Vendor shall remove his business from a public parking space within a reasonable time, no more than one hour, following the time the vendor has stopped selling food to persons. Vendor must still comply with all other restrictions regarding its location in a public parking space.
- e. Vendor will comply with all other laws, ordinances, rules and regulations in effect at the time it conducts their business, including, but not limited to: (1) Bloomington Municipal Code 4.28 (Mobile Vendors), and (2) all City parking regulations, restrictions, and ordinances.
- f. Vendor is prohibited from operating within a one block radius of a Special Event, unless prior approval has been granted by either the operator of the Special Event or the City’s Board of Public Works. The Board of Public Works is not required to provide specific notice to Vendor when it recognizes a Special Event. The following are Special Events that have been recognized by the Board of Public Works:
 - 1) City of Bloomington Farmers’ Market;
 - 2) City of Bloomington Holiday Market;
 - 3) The Taste of Bloomington;
 - 4) Lotus World Music and Arts Festival;
 - 5) The Fourth Street Festival;
 - 6) Arts Fair on the Square;
 - 7) Strawberry Festival;
 - 8) Canopy of Lights;
 - 9) Fourth of July Parade; and
 - 10) Any other special events approved by the City Controller.

ADOPTED THIS THE 21st DAY OF MAY, 2024.

BOARD OF PUBLIC WORKS:

Kyla Cox Deckard, President

Elizabeth Karon, Vice President

James Roach, Secretary

ALL TERMS AND CONDITIONS CONTAINED IN THIS RESOLUTION 2024-027 ARE ACCEPTABLE AND AGREED TO BY VENDOR:

Ahmad Naderi

Date: _____



Board of Public Works Staff Report

Project/Event: 4th and Rogers Block Party

Petitioner/Representative: Lauren Kniss – FAR Center for Contemporary Arts

Staff Representative: April Rosenberger

Meeting Date: May 21, 2024

Organizers are requesting the closure of 4th Street, one block East of Rogers and West between Rogers and the alley to the West of Prospect Hill Place beginning at 3:00 p.m. for set up until 11:00 p.m., which will allow for clean up after the 5:00 p.m. – 10:00 p.m. event on Friday, June 7, 2024. The 5th Annual 4th and Rogers block party celebrates the neighborhoods surrounding 4th and Rogers Streets. The block party will include giveaways, live music, family-friendly activities, and various food truck options.

A noise permit is also requested as part of this event.

All Businesses have received notice of this event and public meeting for comment.



**JOHN HAMILTON
MAYOR**

CITY OF BLOOMINGTON

401 N Morton St Suite 150
PO Box 100
Bloomington IN 47402

**DEPARTMENT OF PUBLIC WORKS
DEPARTMENT OF ECONOMIC
& SUSTAINABLE DEVELOPMENT**

ESD 812.349.3418
PW 812.349.3411

Greetings from the City of Bloomington!

This application is for approval from the Board of Public Works for Temporary Special Events for the use of public rights of way owned by the City of Bloomington. To assure timely approval by the Board of Public Works to your application we ask that you notify us three (3) months in advance.

Applications will not be considered unless all relevant portions of the application have been completed in their entirety. Once a completed application is submitted to the City it will be reviewed by City Staff and will then go before the Board of Public Works for consideration. Once approved by the Board of Public Works, the City retains the right to revoke permission if event becomes a public safety concern.

The Board of Public Works has the sole discretion as to whether or not a special approval shall be granted. If the Board of Public Works issues a special approval for use of public right-of-way the Board may prescribe any reasonable conditions or requirements it deems necessary to minimize the adverse effects upon the Bloomington community, surrounding neighborhoods, or emergency service providers.

If the Board of Public Works issues the special approval, the permit holder shall still abide by all other city, county, state and federal laws.

The City of Bloomington
Department of Economic and Sustainable Development

✓



SPECIAL EVENT APPLICATION

City of Bloomington
 Department of Economic and Sustainable Development
 401 N. Morton Street, Suite 150
 Bloomington, Indiana 47404
 812-349-3418
 Department of Public Works
 812-349-3411

1. APPLICANT INFORMATION

Contact Name:	Lauren Kniss		
Contact Phone:	812-336-0000	Mobile Phone:	703-915-5626
Title/Position:	Director		
Organization:	FAR Center for Contemporary Arts		
Address:	505 W. 4th Street		
City, State, Zip:	Bloomington In 47404		
Contact E-Mail Address:	lauren@thefar.org		
Organization E-Mail and URL:	info@thefar.org www.thefar.org		
Org Phone No:	812-336-0000	Fax No:	

2. ANY KEY PARTNERS INVOLVED (including Food Vendors if applicable)

Organization Name:	Rainbow Bakery		
Address:	210 S Rogers Street		
City, State, Zip:	Bloomington IN 47404		
Contact E-Mail Address:	erin@hopscotchcoffee.com		
Phone Number:	812-671-3804	Mobile Phone:	
Organization Name:	I Fell Gallery		
Address:	415 W 4th Street		
City, State, Zip:	Bloomington IN 47404		
E-Mail Address:	*****		
Phone Number:		Mobile Phone:	
Organization Name:			
Address:			
City, State, Zip:			
E-Mail Address:			
Phone Number:		Mobile Phone:	



3. EVENT INFORMATION

Type of Event	<input type="checkbox"/> Metered Parking Space(s) <input type="checkbox"/> Run/Walk <input type="checkbox"/> Festival <input checked="" type="checkbox"/> Block Party <input type="checkbox"/> Parade <input type="checkbox"/> Art in the Right of Way <input type="checkbox"/> Other (Explain below in Description of Event)	
Date(s) of Event:	Friday June 2, 2023	
Time of Event:	Date: 6/2/2323 Start: 5 pm	Date: 6/2/23 End: 10 pm
Setup/Teardown time Needed	Date: 6/2/23 Start: 3 pm	Date: 6/2/23 End: 12 pm
Calendar Day of Week:	Friday June 2, 2023	
Description of Event:	4rd Annual 4th and Rogers Block Party to celebrate the neighborhoods surrounding Fourth and Rogers Streets. Includes Gallery Walk art openings at the Pictura Gallery/FAR Center, I Fell, and Rainbow Bakery with participation from neighbor organizations and businesses. Previous year's partners included Limestone Post, Lotus, rock paper scissors, Rhett Skateboarding, Monroe County Democrats, WFHB, Persimmon Inn, Downtown Bloomington Inc, Indiana Recovery Alliance, Satori Martial Arts, and more. These organizations had tables set up with info, giveaways, live music, and family-friendly activities. Various food truck options along with live music is planned.	
Expected Number of Participants:	300	Expected # of vehicles (Use of Parking Spaces to close):

4. IF YOUR EVENT IS A **NEIGHBORHOOD BLOCK PARTY**, YOU ARE REQUIRED TO SECURE AND ATTACH THE FOLLOWING:

<input checked="" type="checkbox"/>	A map of the proposed rights-of-way closure or route in its entirety (streets shall be properly labeled and identified) <ul style="list-style-type: none"> • The starting point shall be clearly marked • The ending point shall be clearly marked • Each intersection along the route shall be clearly identified • A notation of how each intersection is to be blocked shall be specifically noted at each intersection (where type 3 barricades will be placed)
<input checked="" type="checkbox"/>	Notification to businesses/residents that will be impacted by event (copy of notification letter/flyer/other)
<input checked="" type="checkbox"/>	A properly executed Maintenance of Traffic Plan <ul style="list-style-type: none"> • Determine if No Parking Signs will be required
<input checked="" type="checkbox"/>	Noise Permit application

N/A

5. IF YOUR EVENT IS A RUN/WALK/PARADE, YOU ARE REQUIRED TO SECURE AND ATTACHED THE FOLLOWING: *Moving Events – Use and/or Closure of City Streets/Sidewalks*

<input type="checkbox"/>	A map of the proposed rights-of-way closure or route in its entirety (streets shall be properly labeled and identified) <ul style="list-style-type: none"> The starting point shall be clearly marked The ending point shall be clearly marked The number of lanes to be restricted on each road shall be clearly marked Each intersection along the route shall be clearly identified A notation of how each intersection is to be blocked shall be specifically noted at each intersection (i.e.: Type 3 barricades and/or law enforcement); and The location of any staging area(s) for the rights-of-way closure and how much space the staging area(s) shall utilize
<input type="checkbox"/>	Notification to businesses /residents that will be impacted by event of the day the application will be heard by Board of Public Works (Example attached)
<input type="checkbox"/>	Using a City park or trail? Parks & Recreation Department Approved Special Use Permit <input type="checkbox"/> Not applicable
<input type="checkbox"/>	Certificate of Liability Insurance – Proof of insurance listing the City of Bloomington as additional insured for an amount no less than \$1,000,000 per occurrence and \$2,000,000 in the aggregate. DEADLINE: To Public Works no later than five days before event.
<input type="checkbox"/>	A properly executed Maintenance of Traffic Plan *Determine if No Parking Signs will be required * Determine if Barricades will be required
<input type="checkbox"/>	Secured a Parade Permit from Bloomington Police Department <input type="checkbox"/> Not applicable
<input type="checkbox"/>	Noise Permit application <input type="checkbox"/> Not applicable
<input type="checkbox"/>	Waste and Recycling Plan if more than 100 participates (template attached)

N/A

6. If YOUR EVENT IS A FESTIVAL/SPECIAL COMMUNITY EVENT YOU ARE REQUIRED TO SECURE AND ATTACH, AND SUBMIT THE FOLLOWING: *Stationary Events – Closure of Streets/Sidewalks/Use of Metered Parking*

<input type="checkbox"/>	A map of the proposed rights-of-way closure in its entirety (streets shall be properly labeled and identified) The starting point shall be clearly marked <ul style="list-style-type: none"> The ending point shall be clearly marked The number of lanes to be restricted on each road shall be clearly marked Each intersection along the route shall be clearly identified A notation of how each intersection is to be blocked shall be specifically noted at each intersection (ie: type 3 barricades and/or law enforcement); and The location of any staging area(s) for the rights-of-way closure and how much space the staging area(s) shall utilize
<input type="checkbox"/>	Notification to business/residents who will be impacted by event of the day the application will be heard by Board of Public Works (Example attached)
<input type="checkbox"/>	Using a City park or trail? Parks & Recreation Department Approved Special Use Permit <input type="checkbox"/> Not applicable
<input type="checkbox"/>	A properly executed Maintenance of Traffic Plan *Determine if No Parking Signs will be required * Determine if Barricades will be required
<input type="checkbox"/>	Noise Permit application <input type="checkbox"/> Not applicable
<input type="checkbox"/>	Beer & Wine Permit <input type="checkbox"/> Not applicable
<input type="checkbox"/>	Certificate of Liability Insurance listing the City of Bloomington as additional insured. For an amount not less than \$1,000,000 per occurrence and \$2,000,000 in the aggregate. DEADLINE: To Public Works no later than five days before event.
<input type="checkbox"/>	If Food Vendors are part of Festival (Monroe County Health Department Licenses & Fire Inspection)
<input type="checkbox"/>	Waste and Recycling Plan if more than 100 participates (template attached)



7. CHECKLIST

<input checked="" type="checkbox"/>	Determine type of Event
<input checked="" type="checkbox"/>	Complete application with attachment: <ul style="list-style-type: none"> <input checked="" type="checkbox"/> Detailed Map <input checked="" type="checkbox"/> Proof of notification to businesses/residents (copy of letter/flyer/other) <input checked="" type="checkbox"/> Maintenance of Traffic Plan <input checked="" type="checkbox"/> Noise Permit Application (if applicable) <input checked="" type="checkbox"/> Certificate of Liability Insurance <input type="checkbox"/> Secured a Parade Permit from Bloomington Police Department (if applicable) <input checked="" type="checkbox"/> Beer and Wine Permit (if applicable)Waste and Recycling Plan (if applicable) <input checked="" type="checkbox"/> Waste and Recycling Plan (if applicable) <input type="checkbox"/> For art installations: an accurate depiction of the design of private art to scale, dimensions of the art, placement on the detailed map of proposed location of the art, and the name and qualifications of the artist
<input checked="" type="checkbox"/>	Date Application will be heard by Board of Public Works
<input type="checkbox"/>	Approved Parks Special Use Permit (if using a City Park)
<input checked="" type="checkbox"/>	If using food vendors assure proper paperwork in order (Monroe County Health Department Licenses & Fire Inspection)
<input checked="" type="checkbox"/>	If applicable, acknowledgment of compliance with the City of Bloomington Policy and Procedures on Private Art Installations within the Public Right of Way (Policy attached with application)

FOR CITY OF BLOOMINGTON USE ONLY

Date Received:	Received By:	Date Approved:	Approved By:
	Economic & Sustainable Development		
	Bloomington Police		
	Bloomington Fire		
	Engineering		
	Transit		
	Office of the Mayor		
	Utilities		
	Public Works		
	Board of Public Works		



CITY OF BLOOMINGTON

NOISE PERMIT

City of Bloomington
401 N. Morton St., Suite 120
Bloomington, Indiana 47404
812-349-3411



Application and Permit Information

This is an application for a permit for relief from Chapter 14.09 (Noise Control) of the Bloomington Municipal Code. Any permit granted by the City of Bloomington must contain all conditions upon which said permit shall be effective. The City may prescribe any reasonable conditions or requirements it deems necessary to minimize adverse effects upon the community or the surrounding neighborhood.

Once a completed application is submitted to the City, it will be reviewed by the Board of Public Works. If the permit is approved, the holder must still abide all other city, state, and federal laws.

Contact April Rosenberger with any questions: (812) 349-3411 or april.rosenberger@bloomington.in.gov

Event and Noise Information

Name of Event:	4th and Rogers Block Party		
Location of Event:	4th Street, on either side of Rogers Street		
Date of Event:	June 2, 2023	Time of Event:	Start: 5pm
Calendar Day of Week:	Friday		End: 9pm
Description of Event:	4th Annual 4th and Rogers Block Party to celebrate the neighborhoods surrounding Fourth and Rogers Streets. Includes Gallery Walk art openings at Pictura/FAR, I Fell, and Rainbow Bakery with participation from neighbor organizations. Previous year's partners included Limestone Post, Lotus, rock paper scissors, Rhett Skateboarding, Monroe County Democrats, WFHB, Indiana Recovery Alliance, Satori Martial Arts, and more. These organizations had tables set up with info, giveaways, live music, and family-friendly activities. Various food truck options along with live music is planned.		
Source of Noise:	<input checked="" type="checkbox"/> Live Band	<input checked="" type="checkbox"/> Instrument	<input type="checkbox"/> Loudspeaker
			Will Noise be Amplified? <input checked="" type="checkbox"/> Yes <input type="checkbox"/> No
Is this a Charity Event?	<input type="checkbox"/> Yes <input checked="" type="checkbox"/> No	If Yes, to Benefit:	

Applicant Information

Name:	Lauren Kniss		
Organization:	FAR Center for Contemporary Arts	Title:	Director
Physical Address:	505 W 4th Street Bloomington IN 47404		
Email Address:	lauren@thefa.org	Phone Number:	81-336-0000
Signature:	<i>Lauren Kniss</i>	Date:	3/21/2023

FOR CITY OF BLOOMINGTON USE ONLY

In accordance with Section 14.09.070 of the Bloomington Municipal Code, We, the Board of Public Works, the designee of the Mayor of the City of Bloomington, hereby waive the City Noise Ordinance for the above mentioned event.

BOARD OF PUBLIC WORKS	
_____	_____
Kyla Cox Deckard, President	Elizabeth Karon, Vice-President
_____	_____
Date	James Roach, Secretary

June 2023 4th and Rogers Block Party

Event Map
Waste and Recycling Plan / Maintenance of Traffic Plan

 = TRASH AND RECYCLING CONTAINERS

 = TYPE 3 BARRICADES W/
WATER-FILLED BARRIERS
SUPPLIED BY CITY OF BLOOMINGTON

 = NO PARKING ZONES

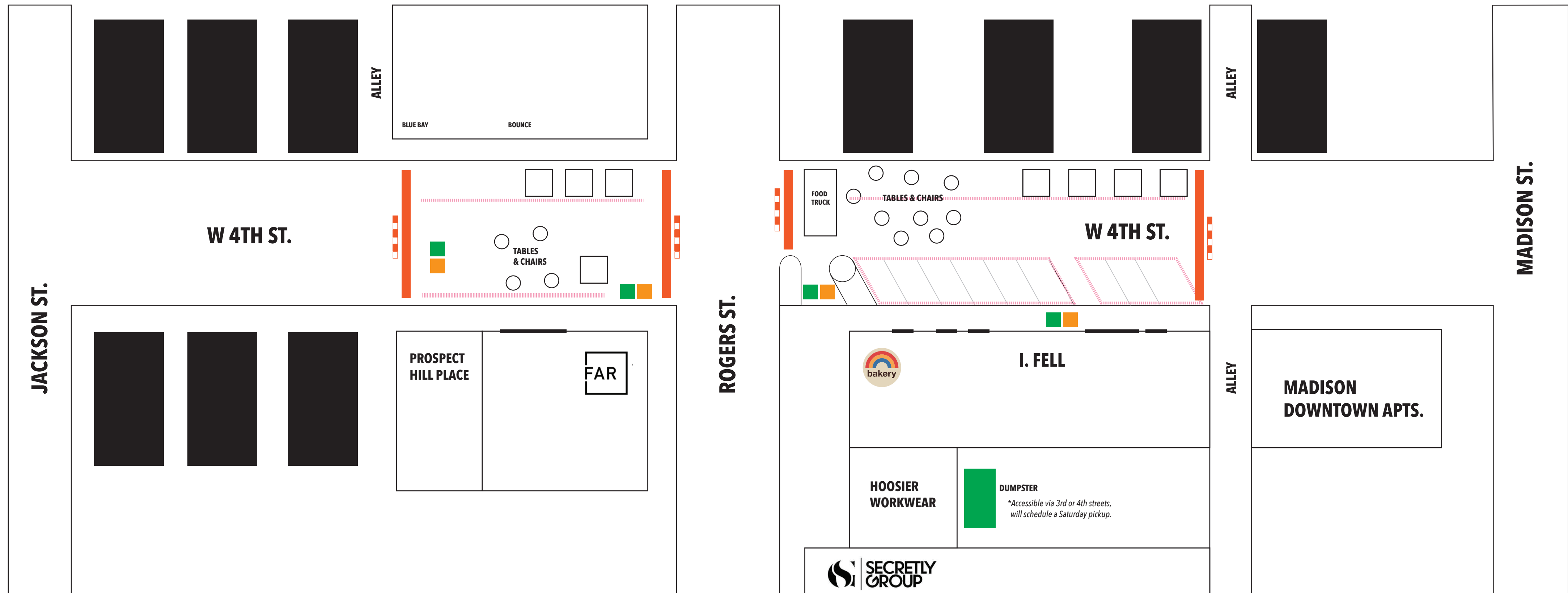

Waste and Recycling Management Plan

Event name: 4th and Rogers Block Party 2023

Number of expected attendees: 300-400

Number of food vendors: 6+

Number of other vendors: 12+

Designated waste and recycling manager: McKenzi Gatlin

Event map: Map Attached

Type of waste

Mixed paper, cans, glass, plastics

Trash and Food Waste

Collection plan

5 bins provided by DBI

5 bins provided by Block Party Organizers

Collection and hauling system: Ava's Waste Removal will deliver a temporary dumpster, placed behind I Fell Gallery. Clearly marked Trash and Recycling Bins will be placed in pairs along 4th street. All Trash and Recycling Bins will be checked regularly throughout the duration of the Block Party by the Waste and Recycling Manager. Bags will be removed and replaced, and contents moved to the collection area behind I Fell for sorting and emptied into the dumpster or shared recycling bins

Vendor and volunteer education and training: The Waste and Recycling Manager will coordinate with the Block Party organizers to educate a set of volunteers with instructions on guiding participants to the appropriate bins, emptying bins, and maintaining the collection area behind I Fell Gallery.

Materials and supplies: 5 Bins for Recycling, and 5 Bins for Trash Collection, 1 dumpster for trash collection and a collection of shared recycling containers from Block Party Organizers. Clear signage on all bins, along with maps marking locations of bins posted throughout the Block Party.

Designation of duties: Waste and Recycling Manager McKenzi Gatlin will coordinate with representatives from the Block Party Organizers, including Lauren Kniss at FAR Center for Contemporary Arts, Erin Tobey from Rainbow Bakery and Emily Wilson Gillespie from I Fell Gallery, along with a group of volunteers.



BEER / WINE AUTHORITY / TYPE 118

State Form 35494 (R9 / 9-19)

53

INSTRUCTIONS:

1. Applicant must complete all requested information.
2. Please type or print clearly.
3. Submit application and payment to the local excise district office.
4. All events are \$50.00 per day (905 IAC 1-11.1-1). Business checks and money orders made payable to the Indiana Alcohol and Tobacco Commission are accepted.
5. Serving past midnight, no later than 3 AM, is one (1) day.
6. No rain checks on any of the listed events.

Visit <https://www.in.gov/atc/sep/2379.htm> for additional information about the districts.

Deliver or mail completed application and payment to:

DISTRICT 1
 52422 County Road 17
 Bristol, IN 46507
 Telephone: (574) 264-9480

DISTRICT 4
 651 S. Frontage Road
 Seymour, IN 47274
 Telephone: (812) 523-8314

DISTRICT 2
 1353 South Governors Drive
 Columbia City, IN 46725
 Telephone: (260) 244-4285

DISTRICT 5
 3650 South US Hwy 41
 Vincennes, IN 47591
 Telephone: (812) 882-1292

DISTRICT 3
 41 West 300 North
 Crawfordsville, IN 47933
 Telephone: (765) 362-8815

DISTRICT 6
 8400 East 30th Street
 Indianapolis, IN 46219
 Telephone: (317) 541-4100

STEP 1. GENERAL INFORMATION

Name of applicant applying for permit (organization, club, corporation, individual) Pictura Gallery		TM Permit number (issued by ATC) TM0098881
Address of applicant (number and street, city, state, and ZIP code) 202 S Rogers Street Bloomington IN 47404		E-mail address lauren@thefar.org
Name of person making application Lauren Kniss	Fax number ()	Emergency contact telephone number (703) 915-5626
Printed name of contact person of event Lauren Kniss		Emergency contact telephone number ()

STEP 2. EVENT INFORMATION

Beginning day Friday June 2	Beginning date (month, day, year) 6/2/2023	Ending day Friday June 2	Ending date (month, day, year) 6/2/2023
Time of event Start time 5:00 <input type="checkbox"/> AM <input checked="" type="checkbox"/> PM		End time 8:00 <input type="checkbox"/> AM <input checked="" type="checkbox"/> PM	
Type or description of event Gallery Opening Reception			
Exact address of event (number and street, city, state, and ZIP code) 202 S. Rogers Street Bloomington IN 47404			

STEP 3. FLOOR PLAN (See Step 4, Number 2.)

Please see attached floorplan

STEP 4. ACKNOWLEDGMENT

In order to qualify for this authority to serve beer and wine, the following guidelines must be met:

1. There must be a well defined premises, i.e. building, tent, enclosure, or fenced-in or designated area.
2. You must have a defined floor plan or diagram. This is to be drawn on Page 1, Step 3 of this application. If minors are to be present, you must have a defined separation between the bar area and family area. *(Must be on floor plan.)*
3. There shall be **NO** carry-out privileges, **NO** carry-in privileges and **NO** spirituous beverages allowed.
4. Each applicant must designate an individual to be responsible for the event and such person shall sign the authority.
5. **ANY** and **ALL** persons dispensing or accepting payment for alcoholic beverages **MUST POSSESS** a valid ATC employee permit.
6. The event must meet applicable Indiana State Board of Health requirements, particularly with regard to restroom facilities.
7. If the event is held in a town park, you must have approval from the town board.
8. Legal Hours of dispensing alcoholic beverages: (Prevailing time)
 Monday through Saturday -- 7 AM to 3 AM the following day
 Sunday -- 7 AM to 3 AM the following day
9. Applicant must file with the district office at which the event will be held at least five (5) days prior to the event.
10. The authority must be posted in the most conspicuous place at the location of the event. An excise officer or commissioner, for good cause, has the authority to revoke the authority during the event.

STEP 5. COMMUNITY CLEARANCE

1. Signature of Sheriff of county, or Chief of Police, or Town Marshall of jurisdiction where the event will be held Date signed (month, day, year)
2. Signature of the mayor (if the event is held in Fort Wayne) Date signed (month, day, year)

Note:

Please post your approved request in a conspicuous place where the alcoholic beverages are being dispensed at the location. If for any reason this request is denied, you may be notified either in person or by telephone.

I swear or affirm under penalties of perjury that the information is true and accurate.

Signature of permittee / agent (Your signature acknowledges that you have read and will abide by the rules and guidelines.) <i>Jan [Signature]</i>	Date signed (month, day, year) <i>12/12/22</i>
---	---

FOR DISTRICT USE ONLY

District number <i>4</i>	Date Issued (month, day, year) <i>1/23/23</i>
Reviewed by Excise Police District Representative <i>Jessie Marks</i>	<input checked="" type="checkbox"/> Approved <input type="checkbox"/> Denied

Alcohol Permit Packet

FAR Weddings & Events

4TH STREET

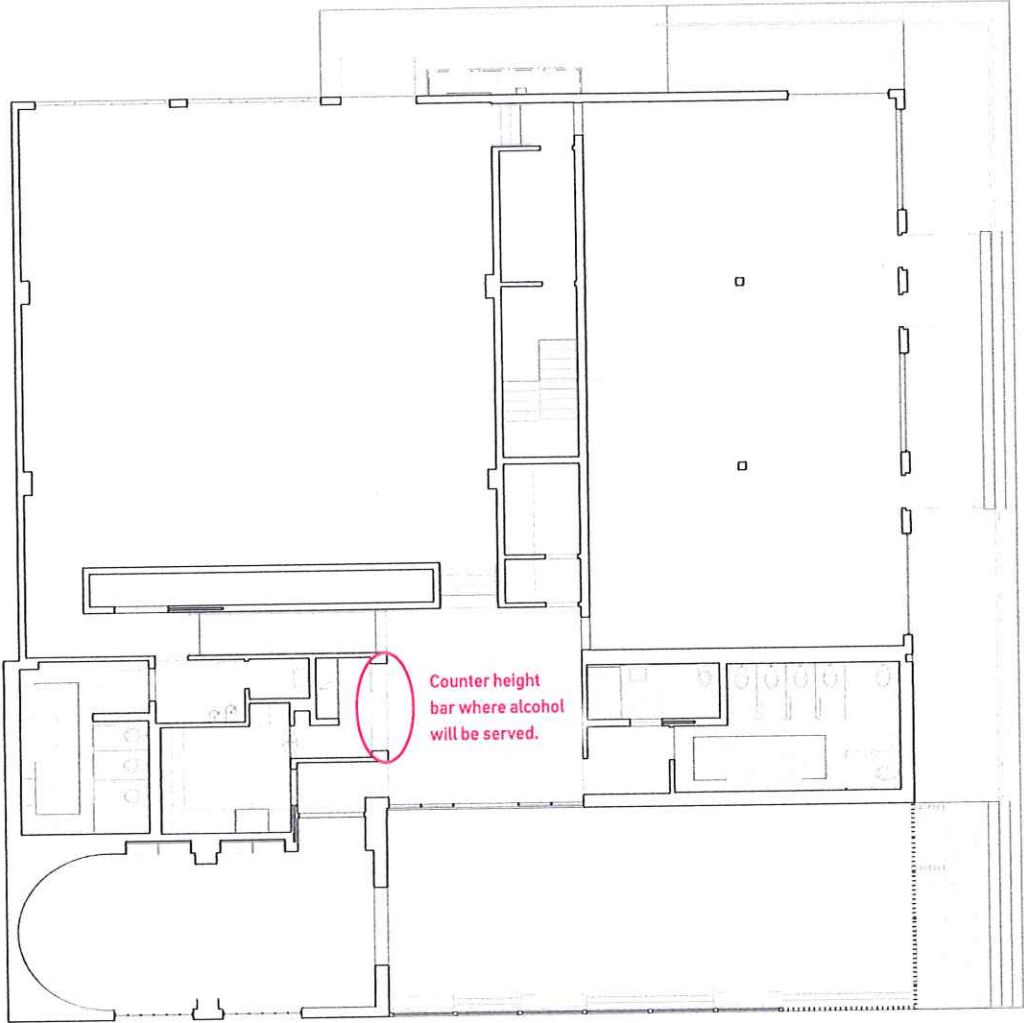

ROGERS STREET



505 W 4th St. Bloomington, IN 47404
events.thefar.org | 812.336.0006



CITY OF BLOOMINGTON

NOTICE OF PUBLIC MEETING LETTER

The Board of Public Works of Bloomington, Indiana, has been petitioned to hear a request for a Special Event in Public Right Way for the 2023 4th and Rogers Block Party.

The Board of Public Works meeting to hear this request will be Tuesday April 25, 2023. Board of Public Works meetings are held virtually via zoom. Zoom information can be found on the Public Works web page at <https://bloomington.in.gov/boards/public-works> or you may also call 812.349.3411 for this information.

The proposal for will be on file and may be examined in the Public Works office on the Friday prior to the Tuesday April 25, 2023, meeting.

All persons interested in said proposal may be heard at the time and place as herein set out. If you would rather voice your opinion by phone, you may call 812.349.3411 or email public.works@bloomington.in.gov. Written and verbal objections filed with the Board of Public Works prior to the hearing will be considered.

BOARD OF PUBLIC WORKS
CITY OF BLOOMINGTON, INDIANA

PETITIONER: FAR Center for Contemporary Arts
DATE: March 23, 2023

NOTIFICATION OF STREET CLOSURE

Friday, June 2, 2023 | 3pm to dark | 400 & 500 blocks of West Fourth Street

CONTACT: Lauren Kniss (FAR Center for Contemporary Arts): lauren@thefar.org

Hello neighbor!

On the afternoon of Friday, June 2, 2023, we are closing parts of West Fourth Street for a neighborhood block party and we hope you will attend! We are celebrating First Friday gallery events at the FAR Center for Contemporary Arts, I Fell, and Rainbow Bakery. There will be food, and drink, music, activities for kids, and more. West Fourth Street will be closed for one half block on either side of Rogers Street, ending at the alley next to Prospect Hill Place to the west and the alley next to Madison Downtown Apartments to the east (Rogers will remain open).

That means that all of the parking on these blocks, as well as drive-up access, will be restricted during the timeframe above. Please get in touch if we can help mitigate any inconvenience this might cause you.

We hope you will join us, and thanks in advance for your flexibility. If you are interested in participating in the organization of this or similar future events, please get in touch!

Lauren Kniss | FAR Center for Contemporary Arts / Pictura Gallery

Cynthia Brubaker | I Fell LLC

Erin Tobey | Rainbow Bakery



I FELL BLOOMINGTON



CERTIFICATE OF LIABILITY INSURANCE

DATE (MM/DD/YYYY)

3/21/2023

THIS CERTIFICATE IS ISSUED AS A MATTER OF INFORMATION ONLY AND CONFERS NO RIGHTS UPON THE CERTIFICATE HOLDER. THIS CERTIFICATE DOES NOT AFFIRMATIVELY OR NEGATIVELY AMEND, EXTEND OR ALTER THE COVERAGE AFFORDED BY THE POLICIES BELOW. THIS CERTIFICATE OF INSURANCE DOES NOT CONSTITUTE A CONTRACT BETWEEN THE ISSUING INSURER(S), AUTHORIZED REPRESENTATIVE OR PRODUCER, AND THE CERTIFICATE HOLDER.

IMPORTANT: If the certificate holder is an ADDITIONAL INSURED, the policy(ies) must have ADDITIONAL INSURED provisions or be endorsed. If SUBROGATION IS WAIVED, subject to the terms and conditions of the policy, certain policies may require an endorsement. A statement on this certificate does not confer rights to the certificate holder in lieu of such endorsement(s).

PRODUCER ISU Insurance Services The May Agency 1327 North Walnut Street PO Box 1669 Bloomington IN 47402	CONTACT NAME: Allison England PHONE (A/C No. Ext): 812-353-6494 E-MAIL ADDRESS: aengland@mayagency.com		FAX (A/C, No): 8112-332-3646	
	INSURER(S) AFFORDING COVERAGE			
INSURED FAR LLC 205 N College Ave Ste 510 Bloomington IN 47404	FARLLC0-01	INSURER A : Auto-Owners Insurance Company		NAIC # 18988
		INSURER B :		
		INSURER C :		
		INSURER D :		
		INSURER E :		
		INSURER F :		

COVERAGES

CERTIFICATE NUMBER: 372924150

REVISION NUMBER:

THIS IS TO CERTIFY THAT THE POLICIES OF INSURANCE LISTED BELOW HAVE BEEN ISSUED TO THE INSURED NAMED ABOVE FOR THE POLICY PERIOD INDICATED. NOTWITHSTANDING ANY REQUIREMENT, TERM OR CONDITION OF ANY CONTRACT OR OTHER DOCUMENT WITH RESPECT TO WHICH THIS CERTIFICATE MAY BE ISSUED OR MAY PERTAIN, THE INSURANCE AFFORDED BY THE POLICIES DESCRIBED HEREIN IS SUBJECT TO ALL THE TERMS, EXCLUSIONS AND CONDITIONS OF SUCH POLICIES. LIMITS SHOWN MAY HAVE BEEN REDUCED BY PAID CLAIMS.

INSR LTR	TYPE OF INSURANCE	ADDL INSD	SUBR WVD	POLICY NUMBER	POLICY EFF (MM/DD/YYYY)	POLICY EXP (MM/DD/YYYY)	LIMITS
A	<input checked="" type="checkbox"/> COMMERCIAL GENERAL LIABILITY <input type="checkbox"/> CLAIMS-MADE <input checked="" type="checkbox"/> OCCUR GEN'L AGGREGATE LIMIT APPLIES PER: <input checked="" type="checkbox"/> POLICY <input type="checkbox"/> PRO-JECT <input type="checkbox"/> LOC OTHER:	Y		5180963800	6/7/2022	6/7/2023	EACH OCCURRENCE \$ 1,000,000 DAMAGE TO RENTED PREMISES (Ea occurrence) \$ 100,000 MED EXP (Any one person) \$ 10,000 PERSONAL & ADV INJURY \$ 1,000,000 GENERAL AGGREGATE \$ 2,000,000 PRODUCTS - COMP/OP AGG \$ 2,000,000 \$
	AUTOMOBILE LIABILITY <input type="checkbox"/> ANY AUTO <input type="checkbox"/> OWNED AUTOS ONLY <input type="checkbox"/> SCHEDULED AUTOS <input type="checkbox"/> HIRED AUTOS ONLY <input type="checkbox"/> NON-OWNED AUTOS ONLY						COMBINED SINGLE LIMIT (Ea accident) \$ BODILY INJURY (Per person) \$ BODILY INJURY (Per accident) \$ PROPERTY DAMAGE (Per accident) \$ \$
	<input type="checkbox"/> UMBRELLA LIAB <input type="checkbox"/> OCCUR <input type="checkbox"/> EXCESS LIAB <input type="checkbox"/> CLAIMS-MADE DED RETENTION \$						EACH OCCURRENCE \$ AGGREGATE \$ \$
	WORKERS COMPENSATION AND EMPLOYERS' LIABILITY ANY PROPRIETOR/PARTNER/EXECUTIVE OFFICER/MEMBER EXCLUDED? (Mandatory in NH) If yes, describe under DESCRIPTION OF OPERATIONS below	Y/N	N/A				<input type="checkbox"/> PER STATUTE <input type="checkbox"/> OTHER E.L. EACH ACCIDENT \$ E.L. DISEASE - EA EMPLOYEE \$ E.L. DISEASE - POLICY LIMIT \$

DESCRIPTION OF OPERATIONS / LOCATIONS / VEHICLES (ACORD 101, Additional Remarks Schedule, may be attached if more space is required)

The City of Bloomington is listed as additional insured.

CERTIFICATE HOLDER**CANCELLATION**

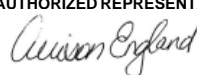
The City of Bloomington 501 N Morton Street Bloomington IN	SHOULD ANY OF THE ABOVE DESCRIBED POLICIES BE CANCELLED BEFORE THE EXPIRATION DATE THEREOF, NOTICE WILL BE DELIVERED IN ACCORDANCE WITH THE POLICY PROVISIONS.
	AUTHORIZED REPRESENTATIVE 

© 1988-2015 ACORD CORPORATION. All rights reserved.

**BOARD OF PUBLIC WORKS
RESOLUTION 2024-028**

4th AND ROGERS BLOCK PARTY

WHEREAS, the Board of Public Works is empowered by I.C. 36-9-6-2 to supervise City Streets; and

WHEREAS, the FAR Center for Contemporary Arts is organizing the 4th and Rogers Block Party, on Friday, June 7, 2024, to take place on 4th Street; and

WHEREAS, the FAR Center for Contemporary Arts has requested that the Board of Public Works allow them to close 4th Street east of Rogers Street between Rogers and Madison, and 4th Street west of Rogers between Rogers and the alley to the west of Prospect Hill Place to vehicular traffic during the Block Party; and

WHEREAS, FAR Center for Contemporary Arts has agreed to provide the City with a Certificate of Insurance naming the City of Bloomington as additionally insured; and

NOW, THEREFORE, BE IT RESOLVED that the City of Bloomington approves the event herein described, provided that:

1. The Board of Public Works declares the above-described event to be an approved Special Event for purposes of Chapters 4.16, 4.28 and 4.30 of the Bloomington Municipal Code.
2. The City of Bloomington Board of Public Works (hereinafter "City") declares that FAR Center for Contemporary Arts may close W. 4th Street east of Rogers Street between Rogers and Madison, and 4th Street west of Rogers between Rogers and the alley to the west of Prospect Hill Place keeping Rogers open to traffic from 3:00 p.m. to 11:00 p.m., allowing time for set-up and tear-down, on Friday, June 7, 2024 for the purpose of staging a block party for the general public.
3. FAR Center for Contemporary Arts shall work with City of Bloomington Parking Enforcement regarding a requested closure of any parking spaces. Parking Enforcement shall post "No Parking" signs at appropriate parking spaces at least 24 hours in advance of their closure.
4. FAR Center for Contemporary Arts shall be responsible for developing an MUTCD compliant Maintenance of Traffic Plan to be approved by the Engineering Department.
5. FAR Center for Contemporary Arts shall obtain, and place FAR Center for Contemporary Arts own expense, any security measures which are deemed prudent and necessary by the Police Department which may include, but are not limited to: anti-vehicle barriers or protection; pedestrian barriers; and other engineering controls or personnel as deemed appropriate. FAR Center for Contemporary Arts agrees no closure shall occur before 3:00 p.m. and to remove barricades by 11:00 p.m. on Friday, June 7, 2024.

6. The City of Bloomington will provide and set up jersey style water filled barricades not before 3:00 p.m. on June 7, 2024. Jersey style water filled barricades will be removed as part of clean-up.
7. FAR Center for Contemporary Arts will be responsible for removing all trash, picking up litter including cigarette butts from the street and sidewalks within this block, cleaning any grease or other food products from the pavement and sidewalks, and removing any “No Parking” signs posted as part of the event.
8. By granting permission to utilize City property to facilitate this activity, the City also waives the City Noise Ordinance in accordance with Section 14.09.070 of the Bloomington Municipal Code, and therefore amplified sound and music may be played during the hours of 5:00 p.m. and 10:00 p.m. on Friday, June 7, 2024.
9. FAR Center for Contemporary Arts shall be responsible for obtaining any and all required permits as well as being responsible for all legal and financial expenditures.
10. FAR Center for Contemporary Arts shall be responsible for notifying the general public, public transit and public safety agencies of the street closing in advance by notice at least 48 hours in advance.
11. In consideration for the use of the City’s property and to the fullest extent permitted by law, FAR Center for Contemporary Arts, for itself, its officers, directors, agents, employees, members, successors and assigns, does hereby indemnify and hold harmless the City of Bloomington, the Board, and the offices, agents and employees of the City and the Board from any and all claims, demands, damages, costs, expenses or other liability arising out of bodily injury or property damage (collectively “Claims”) which may occur as a result of the use of said property, including, but not limited to, any claim or claims brought by third parties, whether or not sounding in tort or contract.
12. _____, by signing this agreement, represents that he/she has been fully empowered by proper action of the entity to enter into the agreement and has authority to do so.

ADOPTED THIS 21st DAY OF MAY 2024.

BOARD OF PUBLIC WORKS:

FAR CENTER FOR CONTEMPORARY ARTS:

Kyla Cox Deckard, President

Signature

Elizabeth Karon, Vice President

Printed Name, Title

James Roach, Secretary

Date



Board of Public Works Staff Report

Project/Event: Blue Ridge Food Truck Nights and Neighborhood Picnic

Petitioner/Representative: Wes Scholl-- Blue Ridge Neighborhood

Staff Representative: April Rosenberger

Meeting Date: May 21, 2024

Wes Scholl, President of the Blue Ridge Neighborhood Association (BRNA) is seeking approval of the temporary street closure of Rusgan Drive from N. Ramble Rd E to the first driveway on Rusgan Drive on Tuesday, June 4, and Tuesday, August 6, and of E. Oliver Drive from N. Ramble Rd E. to N. Ramble Rd W. on Sunday, September 8 (rain date of September 22) from 3:30 p.m. to 8:30 p.m., which includes time for set-up and tear-down, for BRNA's Food Truck Nights and Neighborhood Picnic.



KERRY THOMSON

MAYOR DEPARTMENT OF PUBLIC WORKS DEPARTMENT OF ECONOMIC

CITY OF BLOOMINGTON & SUSTAINABLE DEVELOPMENT 401 N Morton St Suite 150 ESD 812.349.3418 PO Box 100 PW 812.349.3411 Bloomington IN 47402

Greetings from the City of Bloomington!

This application is for approval from the Board of Public Works for Temporary Special Events for the use of public rights of way owned by the City of Bloomington. To assure timely approval by the Board of Public Works to your application we ask that you notify us three (3) months in advance.

Applications will not be considered unless all relevant portions of the application have been completed in their entirety. Once a completed application is submitted to the City it will be reviewed by City Staff and will then go before the Board of Public Works for consideration. Once approved by the Board of Public Works, the City retains the right to revoke permission if event becomes a public safety concern.

The Board of Public Works has the sole discretion as to whether or not a special approval shall be granted. If the Board of Public Works issues a special approval for use of public right-of-way the Board may prescribe any reasonable conditions or requirements it deems necessary to minimize the adverse effects upon the Bloomington community, surrounding neighborhoods, or emergency service providers.

If the Board of Public Works issues the special approval, the permit holder shall still abide by all other city, county, state and federal laws.

The City of Bloomington
Department of Economic and Sustainable Development



CITY OF BLOOMINGTON

SPECIAL EVENT APPLICATION

**City of Bloomington
Department of Economic and Sustainable Development
401 N. Morton Street, Suite 150
Bloomington, Indiana 47404
812-349-3418
Department of Public Works
812-349-3411**

1. APPLICANT INFORMATION

Contact Name:	Wes Scholl		
Contact Phone:	408 839 9811	Mobile Phone:	Same
Title/Position:	BRNA President		

Organization:	Blue Ridge Neighborhood Association		
Address:	416 E Lakewood Dr		
City, State, Zip:	Bloomington IN 47408		
Contact E-Mail Address:	wescholl60@gmail.com		
Organization E-Mail and URL:	blueridgebloomingtonin.org blueridgebloomington@googlegroups.com		
Org Phone No:	None	Fax No:	None

2. ANY KEY PARTNERS INVOLVED (including Food Vendors if applicable)

Organization Name:	None		
Address:			
City, State, Zip:			
Contact E-Mail Address:			
Phone Number:		Mobile Phone:	
Organization Name:			
Address:			
City, State, Zip:			
E-Mail Address:			
Phone Number:		Mobile Phone:	
Organization Name:			
Address:			
City, State, Zip:			
E-Mail Address:			
Phone Number:		Mobile Phone:	

3. EVENT INFORMATION

Type of Event	<input type="checkbox"/> Metered Parking Space(s) <input type="checkbox"/> Run/Walk <input type="checkbox"/> Festival <input checked="" type="checkbox"/> Block Party <input type="checkbox"/> Parade <input type="checkbox"/> Art in the Right of Way <input type="checkbox"/> Other (Explain below in Description of Event)	
Date(s) of Event:	Food Trucks - June 4th, August 6th Picnic - September 8th (rain date of September 22nd)	
Time of Event:	Date: Start: Date: End: All Dates 4PM to 8PM	
Setup/Teardown time Needed	Date: Start: Date: End: All Dates 3:30 and 8:30	
Calendar Day of Week:	Tuesday 6/4, Tuesday 8/6, and Sunday 9/8 (or 9/22)	
Description of Event:	Blue Ridge Neighborhood Association social gatherings for neighborhood residents in 2024 include Food Truck events on Rusgan Drive on 6/4 and on 8/6, and a neighborhood picnic on Oliver Drive on 9/8 (or rain date 9/22). 2-3 food trucks will be invited to the first two events, and neighbors will be invited to gather over the 4 hour period. The picnic will be an organized potluck style meal at 5pm.	
Expected Number of Participants:	30-40 for Food Trucks 75-125 for Picnic	Expected # of vehicles (Use of Parking Spaces to close): N/A

4. IF YOUR EVENT IS A NEIGHBORHOOD BLOCK PARTY, YOU ARE REQUIRED TO SECURE AND ATTACH THE FOLLOWING:

X	A map of the proposed rights-of-way closure or route in its entirety (streets shall be properly labeled and identified) <ul style="list-style-type: none"> • The starting point shall be clearly marked • The ending point shall be clearly marked • Each intersection along the route shall be clearly identified • A notation of how each intersection is to be blocked shall be specifically noted at each intersection (where type 3 barricades will be placed)
---	---

X	Notification to businesses/residents that will be impacted by event (copy of notification letter/flyer/other)
X	A properly executed Maintenance of Traffic Plan <ul style="list-style-type: none"> • Determine if No Parking Signs will be required : Not Required
X	Noise Permit application - No amplified music or excessive noise is planned.

5. IF YOUR EVENT IS A RUN/WALK/PARADE, YOU ARE REQUIRED TO SECURE AND ATTACHED THE FOLLOWING: Moving Events – Use and/or Closure of City Streets/Sidewalks

<input type="checkbox"/>	A map of the proposed rights-of-way closure or route in its entirety (streets shall be properly labeled and identified) <ul style="list-style-type: none"> • The starting point shall be clearly marked • The ending point shall be clearly marked • The number of lanes to be restricted on each road shall be clearly marked • Each intersection along the route shall be clearly identified • A notation of how each intersection is to be blocked shall be specifically noted at each intersection (i.e.: Type 3 barricades and/or law enforcement); and • The location of any staging area(s) for the rights-of-way closure and how much space the staging area(s) shall utilize
<input type="checkbox"/>	Notification to businesses /residents that will be impacted by event of the day the application will be heard by Board of Public Works (Example attached)
<input type="checkbox"/>	Using a City park or trail? Parks & Recreation Department Approved Special Use Permit qNot applicable
<input type="checkbox"/>	Certificate of Liability Insurance – Proof of insurance listing the City of Bloomington as additional insured for an amount no less than \$1,000,000 per occurrence and \$2,000,000 in the aggregate. DEADLINE: To Public Works no later than five days before event.
<input type="checkbox"/>	A properly executed Maintenance of Traffic Plan <ul style="list-style-type: none"> *Determine if No Parking Signs will be required * Determine if Barricades will be required
<input type="checkbox"/>	Secured a Parade Permit from Bloomington Police Department qNot applicable
<input type="checkbox"/>	Noise Permit application qNotapplicable
<input type="checkbox"/>	Waste and Recycling Plan if more than 100 participates (template attached)

6. If YOUR EVENT IS A FESTIVAL/SPECIAL COMMUNITY EVENT YOU ARE REQUIRED TO SECURE AND ATTACH, AND SUBMIT THE FOLLOWING: Stationary Events – Closure of Streets/Sidewalks/Use of Metered Parking

<input type="checkbox"/>	A map of the proposed rights-of-way closure in its entirety (streets shall be properly labeled and identified) The starting point shall be clearly marked <ul style="list-style-type: none"> • The ending point shall be clearly marked • The number of lanes to be restricted on each road shall be clearly marked • Each intersection along the route shall be clearly identified • A notation of how each intersection is to be blocked shall be specifically noted at each intersection (ie: type 3 barricades and/or law enforcement); and • The location of any staging area(s) for the rights-of-way closure and how much space the staging area(s) shall utilize
<input type="checkbox"/>	Notification to business/residents who will be impacted by event of the day the application will be heard by Board of Public Works (Example attached)
<input type="checkbox"/>	Using a City park or trail? Parks & Recreation Department Approved Special Use Permit <input type="checkbox"/> Not applicable
<input type="checkbox"/>	A properly executed Maintenance of Traffic Plan *Determine if No Parking Signs will be required * Determine if Barricades will be required
<input type="checkbox"/>	Noise Permit application X Not applicable
<input type="checkbox"/>	Beer& Wine Permit X Not applicable
<input type="checkbox"/>	Certificate of Liability Insurance listing the City of Bloomington as additional insured. For an amount not less than \$1,000,000 per occurrence and \$2,000,000 in the aggregate. DEADLINE: To Public Works no later than five days before event.
<input type="checkbox"/>	If Food Vendors are part of Festival (Monroe County Health Department Licenses & Fire Inspection)
<input type="checkbox"/>	Waste and Recycling Plan if more than 100 participates (template attached)

7. CHECKLIST

<input type="checkbox"/>	Determine type of Event
<input type="checkbox"/>	Complete application with attachment: <ul style="list-style-type: none"> <input type="checkbox"/> Detailed Map <input type="checkbox"/> Proof of notification to businesses/residents (copy of letter/flyer/other) <input type="checkbox"/> Maintenance of Traffic Plan <input type="checkbox"/> Noise Permit Application (if applicable) <input type="checkbox"/> Certificate of Liability Insurance <input type="checkbox"/> Secured a Parade Permit from Bloomington Police Department (if applicable) <input type="checkbox"/> Beer and Wine Permit (if applicable)Waste and Recycling Plan (if applicable) <input type="checkbox"/> Waste and Recycling Plan (if applicable) <input type="checkbox"/> For art installations: an accurate depiction of the design of private art to scale, dimensions of the art, placement on the detailed map of proposed location of the art, and the name and qualifications of the artist
<input type="checkbox"/>	Date Application will be heard by Board of Public Works
<input type="checkbox"/>	Approved Parks Special Use Permit (if using a City Park)

<input type="checkbox"/>	If using food vendors assure proper paperwork in order (Monroe County Health Department Licenses & Fire Inspection)
<input type="checkbox"/>	If applicable, acknowledgment of compliance with the City of Bloomington Policy and Procedures on Private Art Installations within the Public Right of Way (Policy attached with application)

For City Of Bloomington Use Only

Works

Date Received: Received By: Public

Date Approved: Approved By:

	Board of Public Works		
	Bloomington Police		
	Bloomington Fire		
	Engineering		
	Legal		
	Office of The Mayor		
	Parking Enforcement		
	Utilities		



NOISE PERMIT

City of Bloomington
 401 N. Morton St., Suite120
 Bloomington, Indiana47404
 812-349-3410

Application and Permit Information

This is an application for a permit for relief from Chapter 14.09 (Noise Control) of the Bloomington Municipal Code. Any permit granted by the City of Bloomington must contain all conditions upon which said permit shall be effective. The City may prescribe any reasonable conditions or requirements it deems necessary to minimize adverse effects upon the community or the surrounding neighborhood.

Once a completed application is submitted to the City, it will be reviewed by the Board of Public Works. If the permit is approved, the holder must still abide all other city, state, and federal laws.

Contact April Rosenberger with any questions: (812) 349-3411 or april.rosenberger@bloomington.in.gov

Event and Noise Information

Name of Event:	Blue Ridge Food Truck Nights; Neighborhood Picnic		
Location of Event:	Blue Ridge Neighborhood - Rusgan Drive, Oliver Drive		
Date of Event:	June 4th, August 6th Sept 8th or 22nd	Time of Event:	Start: 4pm
Calendar Day of Week:	Tuesday's and Sundays		End: 8pm

Description of Event:	Food Truck Events - June 4 and August 6 Neighborhood Picnic (potluck) - September 8 with rain date September 22			
Source of Noise:	Live Band	Instrument	Loudspeaker	Will Noise be Amplified? No
Is this a Charity Event?	No	If Yes, to Benefit:		

Applicant Information

Name:	Wes Scholl		
Organization:	BRNA	Title:	Board President
Physical Address:	416 E Lakewood Drive		
Email Address:	wescholl60@gmail.com,	Phone Number:	4088399811
Signature:	Wes Scholl	Date:	April 1 2024

FOR CITY OF BLOOMINGTON USE ONLY

In accordance with Section 14.09.070 of the Bloomington Municipal Code, We, the Board of Public Works, the designee of the Mayor of the City of Bloomington, hereby waive the City Noise Ordinance for the above mentioned event.

BOARD OF PUBLIC WORKS	Elizabeth Karon, Vice-President
Kyla Cox Deckard, President	James Roach, Secretary
Date	—

Waste and Recycling Management Plan Template

Event name:

Number of expected attendees:

Number of food vendors:

Number of other vendors:

Designated waste and recycling manager: This may be a staff member or a volunteer. Events expecting over 100 attendees are required to designate a waste and recycling manager who will be in charge of overseeing the

implementation of the waste and recycling management plan.

Event map: In the event map you submit with your event application, please clearly designate where waste and recycling bins will be placed. Each waste bin should be paired with one or more recycling bins. Also designate any larger collection areas (such as dumpsters) and the path for access by waste haulers.

TIP: Recycling bins should be visually distinct from waste bins, and all bins should be clearly labeled for easy use by attendees.

ClearStream recycling bins are available for use through [Downtown Bloomington, Inc.](#)

Targeted waste: Please enumerate the types of waste expected at the event and plans for collecting each type of item using the following table. Examples are listed, but feel free to modify as appropriate.

Type of waste	Collection plan
<Containers>*	<Recycling, composting, etc.>
<Mixed paper>	<Recycling in on-site, designated bins staffed by volunteers>
<Food waste>	<Composting bins, waste bins, etc.>

*Note that “compostable” plastics are only compostable in industrial composters, which are not available in the Bloomington area. If you opt for compostable items at your event, ensure that they are compostable paper rather than plastic.

Collection and hauling system: Describe where and how waste and recycling will be collected and separated. Include information on how attendees and vendors will be educated on where materials should be placed, including signage, pre-event training and publicity, volunteer-staffed waste management stations, etc.

Events with over 100 attendees must provide staffed (by paid staff or volunteers) waste management stations to ensure that materials are separated according to the waste and recycling management plan.

Vendor and volunteer education and training: Describe your plans for educating volunteers about waste and recycling management plans at the event, and vendors on what materials will be permitted in order to comply with the Plan and to minimize waste through both reduction and recycling.

Materials and supplies: List the materials you plan to have on hand to implement the waste and recycling management plan, including bins, labels, bags, signage, etc.

Designation of duties: Clearly designate the volunteers, staff, or other individuals who will be responsible for implementing each component of the waste and recycling management plan.



RE: Notice of Public Meeting

Dear Sir or Madam:

The Board of Public Works of Bloomington, Indiana, has been petitioned to hear a request for a Special Event in the Public Right Way for .

The Board of Public Works meeting to hear this request will be on at 5:30 PM. Board of Public Works meetings are held virtually via zoom and in person in the City of Bloomington Council Chambers at City Hall, 401 N. Morton Street, Bloomington, Room 115.

Zoom information for the meeting may be found on the Public Works web page at <https://bloomington.in.gov/boards/public-works> or you may also call 812.349.3411 for zoom information.

The proposal for this event will be on file and may be examined in the Public Works office on Friday, , prior to the Tuesday, meeting. All persons interested in said proposal may be heard at the time and place as herein set out. If you would rather voice your opinion by phone you may call 812.349.3411 or email public.works@bloomington.in.gov. Written and verbal objections filed with the Board of Public Works prior to the hearing will be considered.

**BOARD OF PUBLIC WORKS
CITY OF BLOOMINGTON, INDIANA**

Petitioner:

Date:

<u>Contact Information- Other</u>			
	<u>Location</u>	<u>Contact</u>	<u>Phone Number</u>
Maintenance of Traffic Plan	401 N. Morton St. Suite 130 Bloomington, IN	City of Bloomington Engineering	(812) 349-3913
Monroe County Health Department (Food Handler Permit)	119 W. 7th St. Bloomington, IN	Nicole Wagner	(812) 349-2543
Waste & Recycling Plan	401 N. Morton Street Suite 150	Lauren Travis Economic & Sustainable Development	(812) 349-3837
Bloomington Board of Public Works	401 N. Morton St. Suite 120 Bloomington, IN	April Rosenberger Dept. of Public Works	(812) 349-3411

Bloomington Parks and Recreation Department (Events on City of Bloomington Parks Property)	401 N. Morton St. Suite 250 Bloomington, IN	Leslie Brinson Community Events Manager	(812) 349-3700
Bloomington Fire Department	226 S. College Bloomington, IN	Fire Administration	(812) 332-9763
Bloomington Police Department (Parade Permit)	220 E. Third Bloomington, IN	Police Administration	(812) 339-4477
Master Rental	2022 W. 3 rd Street Bloomington, IN	Type 3 Barricades	(812) 332-0600
Indiana Traffic Services	3867 N. Commercial Parkway Greenfield, IN 46140	Type 3 Barricades	(317) 891-8065
Monroe County Emergency Management	5850 Foster Curry Bloomington, IN		(812)- 349-2546
Department of Homeland Security		Mike Anderson	(317) 409-9510



CITY OF BLOOMINGTON

City of Bloomington Policy and Procedures on Private Art Installations within the Public Right of Way

The City of Bloomington's Policy and Procedures on Private Art Installations within the Public Right of Way ("Policy") authorizes private Art Installations in the public right of way that comply with this document and are approved through one of two City programs: (1) the Neighborhood Improvement Grant Program or (2) a Special Event Application.

This Policy is designed to reduce the risks to public safety and burden on public resources that private Art Installations within the right of way may impose while simultaneously recognizing the importance of private as well as public art to Bloomington's culture, community, and economy.

I. Definitions. The following definitions shall apply throughout this policy.

- A. Temporary Art. Art expected to remain in place within the public right of way for seven (7) or fewer days.
- B. Semi-Permanent Art or Permanent Art. Art expected to remain in place within the public right of way for more than seven (7) days.
- C. Art Installation. Temporary, Semi-Permanent, or Permanent Art that consists of a physical alteration of the right of way, such as a painting, mural, or sculpture and that is not Performative Art.
- D. Street Painting or Street Mural. Art involving the placement of paint or a similar material within the area where vehicles drive or park, commonly understood to be the space "between the curbs."
- E. Performative Art. A time-based art form that is an ephemeral event featuring a live presentation to an audience, drawing on such arts as acting, poetry, music, or dance, and that does not involve the creation of an artifact (such as a painting or sculpture) that physically alters the right of way beyond the time of the live performance.

1

- F. Speech. Words, letters, numbers, universally recognized symbols, or logos of any kind.

II. Performative Art. This policy does not apply to Performative Art.¹

III. Criteria Applicable to All Private Art Installations. The following criteria are applicable to any private Art Installation proposed within Bloomington's right of way, whether the Art Installation is Temporary Art, Semi-Permanent Art, or Permanent Art.

- A. Requests must be submitted to the appropriate City Department(s) and/or Board(s) or Commission(s), as required by the selected program application identified in Section VI below. Staff shall provide a recommendation on the request to the appropriate Board(s) or Commission(s) based on the request's compliance with this Policy and any other applicable laws, rules, or City of Bloomington policies.

B. Art Installations may not use or incorporate copyrighted material in whole or part where the copyright is not owned by the artist.

C. Art Installations may not mimic in whole or part traffic control devices including but not limited to a crosswalk, stop sign, stop bar, or similar traffic control device. Art Installation geometry should be such that drivers do not alter their course to drive around the art.

D. Art Installations may not depict activities, materials, images, or products that are not legally available to all ages.

IV. Additional Criteria Applicable to Semi-Permanent Art Installations or Permanent Art Installations.

A. Applications for approval of a Semi-Permanent or Permanent Art Installation within the right of way must include the following:

1. An accurate depiction of the design to scale;
2. Dimensions;
3. A map of proposed location of the design; and
4. The name and qualifications of the artist.

¹ Though this Policy does not apply to Performative Art taking place within the right of way, other municipal policies or ordinances may apply that impact Performative Art within the right of way, including but not limited to the City's parade ordinance or special event application process.

2

B. Semi-Permanent Art Installations or Permanent Art Installations may not contain Speech.

V. Additional Criteria Applicable to Street Paintings or Street Murals. Because paintings and murals within the street create a heightened probability of conflicts with traffic control devices and driver distraction, the following additional criteria apply to all paintings or murals proposed for street surfaces, whether as Temporary, Semi-Permanent, or Permanent Art Installations.

A. Applications for approval of a Street Painting or Street Mural within the right of way must include the following:

1. An accurate depiction of the design to scale;
2. Dimensions;
3. A map of proposed location of the design; and
4. The name and qualifications of the artist.

B. Street paintings and street murals may only be placed on streets with a local or secondary collector functional classification under the City's Transportation Plan, where regulatory speed limits do not exceed 25 miles per hour.

- C. Street paintings and street murals may only be placed on pavement in adequate condition for materials to bond.
- D. Street paintings and street murals are not permitted on brick, paver, or other decorative surface materials (e.g., colored or stamped concrete). Street paintings and street murals are only permitted on standard non-decorative concrete or asphalt.
- E. A buffer of four feet must remain between street paintings and street murals and any crosswalk.
- F. Within an intersection, street paintings and street murals are only allowed where the intersection utilizes all-way stop control, unless the painting or mural is located on an apron.
- G. Street paintings and street murals may not be painted on the side or top of any curb or any curb ramp.
- H. Materials used must be approved by the City's Engineering Department.

3

- I. Any paint or similar material utilized as part of any street painting or street mural must provide a non-slip surface for pedestrians and must be street-grade.

VI. Programs. Individuals and external organizations seeking to place private Art Installations within the public right of way must apply pursuant to one of the programs listed below and follow the procedures associated with the program, which are linked and attached hereto for reference. Requests to place an Art Installation in the City's right of way using a program or procedure other than those listed below will not be considered.

A. Neighborhood Improvement Grant Program

- 1. Applications for Art Installations within the right of way pursuant to the Neighborhood Improvement Grant Programs must comply with Program guidelines, the criteria set forth in this Policy, and any additional logistical or safety conditions imposed by the Board of Public Works as part of its approval.
- 2. Neighborhood Improvement Grant Program guidelines may be accessed [here](#)² and are attached for reference.

B. Special Event Permit

- 1. A special event application may be submitted for permission to conduct an event during which an Art Installation will be placed in the public right of

way. The proposed Art Installation must comply with the criteria set forth in this policy, the requirements set forth in the special event permit application, and any additional logistical or safety conditions imposed by the Board of Public Works as part of its approval.

2. A special event application may be accessed [here](#)³ and is attached for reference.

² <https://bloomington.in.gov/neighborhoods/grants/improvement>

³ <https://bloomington.in.gov/departments/esd>

Notification to residents on closed streets -

Food Truck Nights (June 4, August 6)

Dear Blue Ridge Residents:

The Blue Ridge Neighborhood Association board is planning a Food Truck night in the neighborhood on Rusgan Road on the first Tuesday of June and August, 2024. The event will run from 4pm to 8pm, and will close the stretch of Rusgan Road from the corner (with N Ramble Road E) to the first driveway from 4pm to 8pm – no driveways will be blocked. I wanted to reach out to see if you had any questions or concerns, as this would be on the road in front of a portion of your lot.

This section of the road would be closed with barricades and parked cars perpendicular to the road at either end, and parking 3-4 food trucks in the road where residents would be directed to purchase and pick up food as they please. Some residents may eat on-site, while others may choose to take the food home to eat. No loud music will be played.

Please reach out to me by email or phone at 408 839 9811 if you have any questions or concerns, and we hope to see you at the event. Thank you!

Sincerely,

Wes Scholl

Neighborhood Picnic (September 8, rain date September 22 2024)

Dear Blue Ridge Residents:

The Blue Ridge Neighborhood Association board is planning its annual Neighborhood Picnic on E Oliver Drive on September 8, 2023 (rain date September 22). The picnic will run from 5pm to 8pm, and will close the entire stretch of Oliver Drive. I wanted to reach out to see if you had any questions or concerns as residents of Oliver Drive.

This section of the road would be closed with barricades and parked cars perpendicular to the road at either end, and tables and chairs in the road where residents will be picnicking. No loud music will be played.

Please reach out to me by email or phone at 4088399811 if you have any questions or concerns, and we hope to see you at the picnic. Thank you!

Sincerely,

Wes Scholl

RUSGAN CLOSURE MAP – June 4 and August 6, 2024

Closing Rusgan Drive from corner of Rusgan and Ramble Rd E, up till first driveway on Rusgan (not blocking driveway. 8 foot traffic barrier will be placed at either side of closure (where vertical arrows indicate). Cars will also be parked perpendicular to the street behind barriers.

Sign at East side of closure, and at corner of Rusgan and Bankers Drive (where horizontal arrows indicate) will read "Road Closed till 8pm, use Lakewood Drive instead"

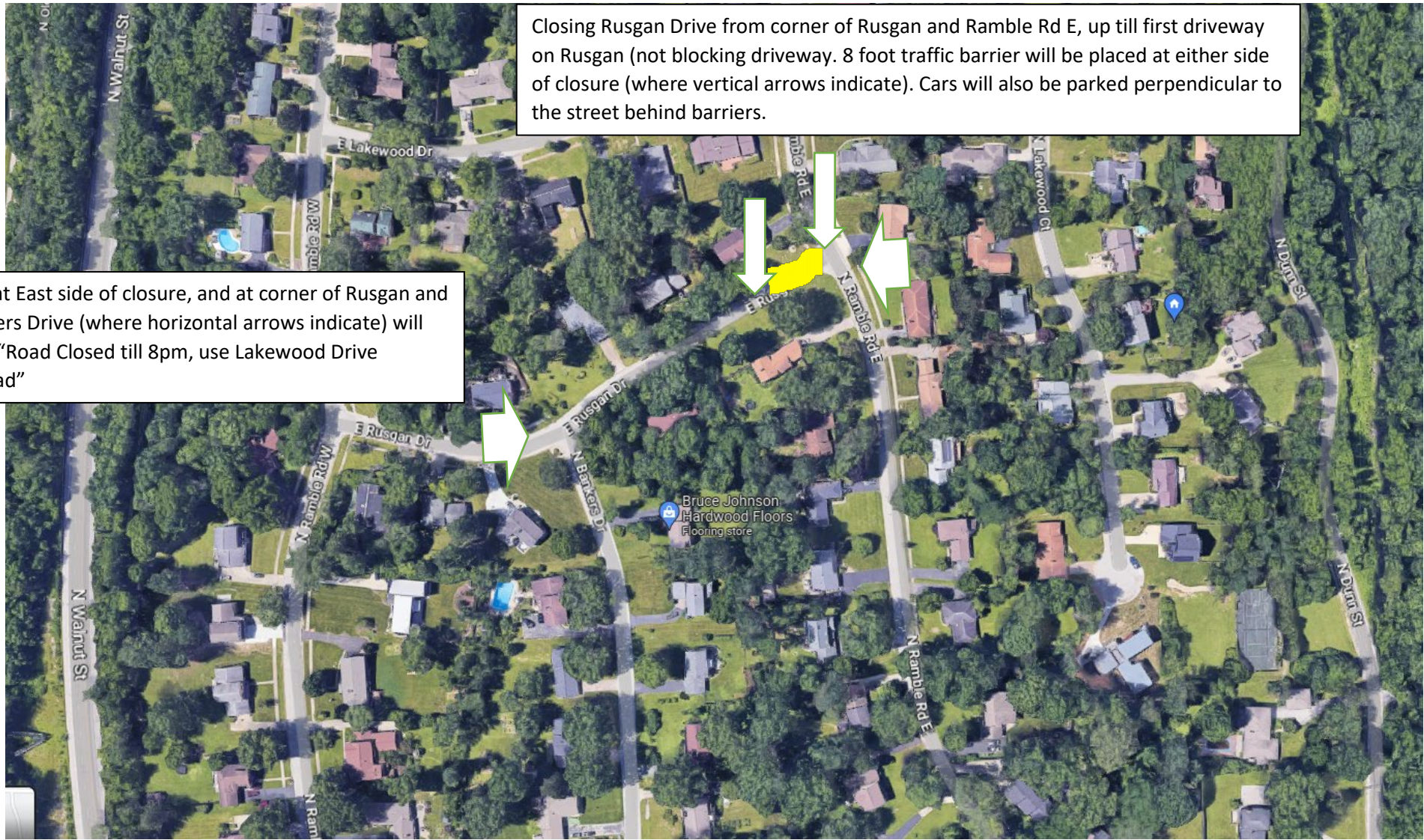

OLIVER CLOSURE MAP – September 8 (rain date September 22)

OLIVER CLOSURE MAP – September 8 (rain date September 22)

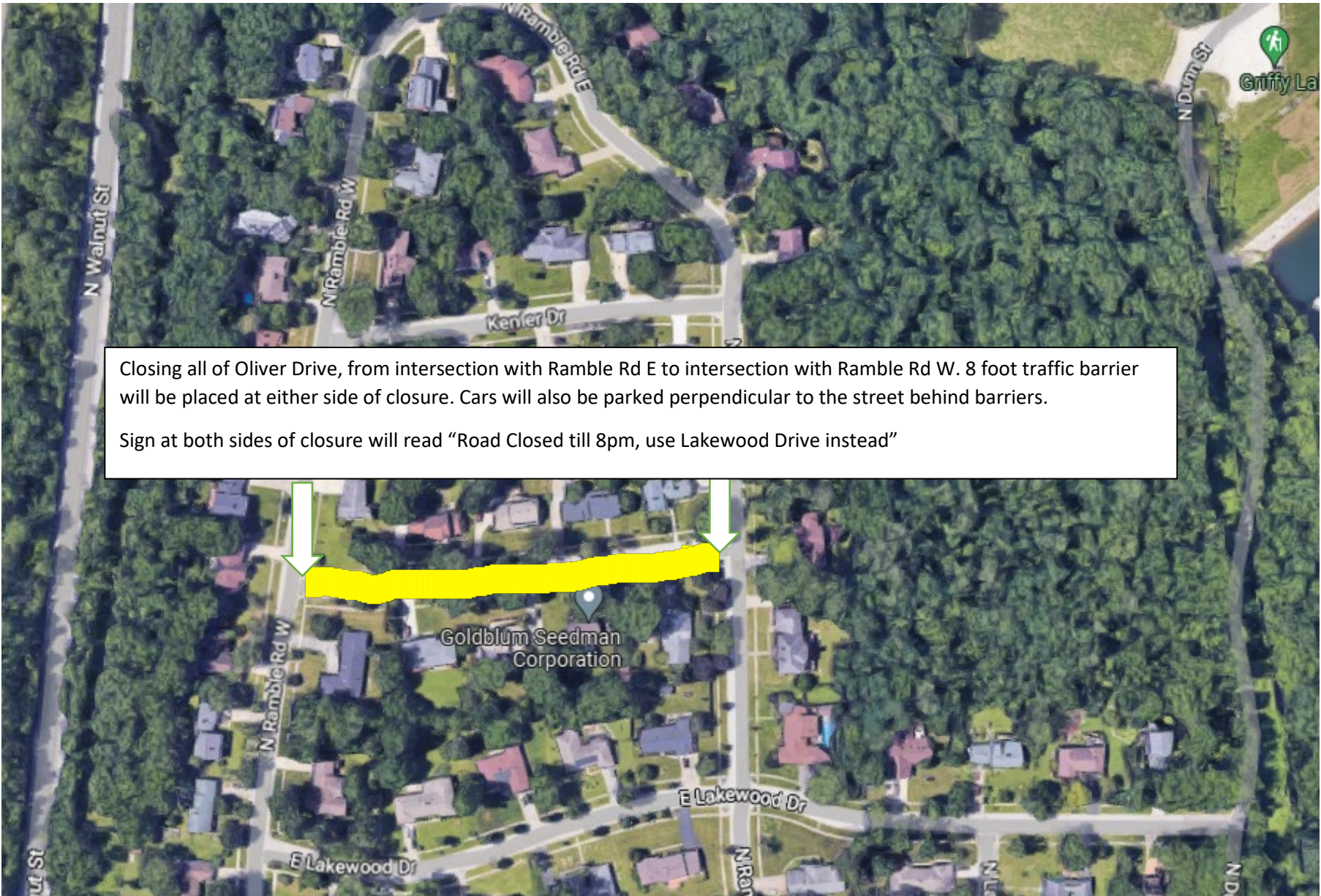

**BOARD OF PUBLIC WORKS
RESOLUTION 2024-029**

Blue Ridge Food Truck Nights and Neighborhood Picnic

WHEREAS, the Board of Public Works is empowered by I.C. § 36-9-6-2 to supervise city streets; and

WHEREAS, Wes Scholl, of the Blue Ridge neighborhood Association, requests authority for the closure of Rusgan Drive on Tuesday, June 04, 2024 and Tuesday, August 04, 2024 for the neighborhood to host Food Truck Nights and of East Oliver Drive on September 08, 2024 (Rain date of September 22, 2024), so that the residents can hold the Blue Ridge Annual Neighborhood Picnic; and

WHEREAS, the City of Bloomington encourages and values activities such as block parties as a way for residents to interact and get to know their neighbors.

NOW, THEREFORE, BE IT RESOLVED THAT:

1. The City of Bloomington Board of Public Works declares that on June 04, 2024 and August 06, 2024 Rusgan Drive will be temporarily closed to motor vehicle traffic from 3:30 p.m. until 8:30 p.m. for the neighborhood to host Food Truck Nights and East Oliver Drive will be temporarily closed to motor vehicle traffic from 3:30 p.m. until 8:30 p.m. on September 8, 2024, so that the neighborhood may stage a neighborhood picnic. Rain date for the picnic is Sunday, September 22, 2024.
2. The street closure outline above is for the purposes of allowing Neighborhood to host neighborhood food truck nights and picnic event.
3. Neighborhood shall be responsible for developing an MUTCD compliant Maintenance of Traffic Plan to be approved by the Engineering Department.
4. The Neighborhood shall obtain, and place at their own expense, any security measures which are deemed prudent and necessary by the Police Department which may include, but are not limited to: anti-vehicle barriers or protection; pedestrian barriers; and other engineering controls or personnel as deemed appropriate. The neighbors agree not to close Rusgan Drive until 3:30 p.m. on Tuesday, June 04, 2024 and Tuesday, August 06, 2024 or East Oliver Drive on Sunday, September 8, 2024, or on Sunday, September 22, 2024, if the earlier date for the neighborhood picnic is rained out.
5. The Neighborhood shall be responsible for obtaining any and all required permits as well as being responsible for all legal and financial expenditures.
6. The Neighborhood shall be responsible for notifying the general public, public transit and public

safety agencies of the street restrictions in advance by notice at least 48 hours in advance.

7. By granting permission to utilize City property to facilitate this activity, the City also waives the City Noise Ordinance in accordance with Section 14.09.070 of the Bloomington Municipal Code, and therefore amplified sound and music may be played during the event.
8. The Neighborhood agrees to clean up the street both before and after the event. The clean-up shall include but not be limited to removal of any food and/or drink residue, picking up litter, sweeping any broken glass, and the placing, emptying and removal of trash cans. Clean-up after each event shall be completed by 8:30 p.m. on the day of the event
9. In consideration for the use of the City’s property and to the fullest extent permitted by law, Neighborhood, for itself, its officers, directors, agents, employees, members, successors and assigns, does hereby indemnify and hold harmless the City of Bloomington, the Board, and the offices, agents and employees of the City and the Board from any and all claims, demands, damages, costs, expenses or other liability arising out of bodily injury or property damage (collectively “Claims”) which may occur as a result of the use of said property, including, but not limited to, any claim or claims brought by third parties, whether or not sounding in tort or contract.
10. _____, a duly authorized representative of the Neighborhood, represents that she has been fully empowered by proper action of the Neighborhood execute this Resolution on behalf of the Neighborhood.

ADOPTED THIS 21st DAY OF MAY, 2024.

BOARD OF PUBLIC WORKS

Blue Ridge Neighborhood

Kyla Cox Deckard, President

Signature

Elizabeth Karon, Vice President

Wes Scholl, Board President
Printed Name and Title

James Roach, Secretary

Date:



Board of Public Works Staff Report

Project/Event: Approve Addendum 3 to Preliminary Engineering Contract with WSP USA for Neighborhood Greenway Projects

Petitioner/Representative: Engineering Department

Staff Representative: Neil Kopper, Senior Project Engineer

Date: 5/21/2024

Report: This contract contains services to complete preliminary engineering tasks for multiple neighborhood greenway projects as prioritized in the City’s Transportation Plan. WSP USA is currently under contract with an overall not-to-exceed amount of \$400,000 for design efforts divided into Task Orders that require individual fee amounts and approvals. Task Order 1 was part of the original overall contract approval and included the planning, public input, and conceptual design efforts for each individual project. This Addendum 3 will modify both Task Order 1 and the overall contract to include a project connecting from the intersection of Olive Street at Hillside Drive to the intersection of Arden Drive at High Street. The existing contract amount of \$400,000 does not change with this addendum. It is expected that a future Addendum will add a new Task Order to provide detailed design services for this newly added project.

<u>Project Approvals Timeline</u>		
<u>Approval Type</u>	<u>Status</u>	<u>Date</u>
Funding Approval	N/A	--
Design Services Contract	Current Item	5/21/2024*
Task Order 1	Current Item	5/21/2024*
Task Order 2	Approved	12/19/2023**
Task Order 3	Future	TBD
Construction Inspection Contract	N/A	--
Construction Contract	Future	TBD

*Originally approved 12/22/2020, modified 12/19/2023

**Originally approved 8/30/2022, modified 12/19/2023

City of Bloomington Contract and Purchase Justification Form

Vendor: WSP USA

Contract Amount: \$400,000

This form should be completed and attached to the contract documents and forwarded to the Legal Department Attorney assigned to your Department. Contracts will not be approved by the Controller if a completed form is not included with the contract documents.

PURCHASE INFORMATION

1. Check the box beside the procurement method used to initiate this procurement: (Attach a quote or bid tabulation if applicable)

<input type="checkbox"/> Request for Quote (RFQ)	<input type="checkbox"/> Request for Proposal (RFP)	<input type="checkbox"/> Sole Source	<input type="checkbox"/> Not Applicable (NA)
<input type="checkbox"/> Invitation to Bid (ITB)	<input checked="" type="checkbox"/> Request for Qualifications (RFQu)	<input type="checkbox"/> Emergency Purchase	

2. List the results of procurement process. Give further explanation where requested. Yes No

# of Submittals: 2	Yes	No		
Met city requirements?	<input checked="" type="checkbox"/>	<input type="checkbox"/>	Was the lowest cost selected? (If no, please state below why it was not.)	<input type="checkbox"/> <input checked="" type="checkbox"/>
Met item or need requirements?	<input checked="" type="checkbox"/>	<input type="checkbox"/>	Qualifications-based selection based on responses to RFQ.	
Was an evaluation team used?	<input checked="" type="checkbox"/>	<input type="checkbox"/>		
Was scoring grid used?	<input checked="" type="checkbox"/>	<input type="checkbox"/>		
Were vendor presentations requested?	<input type="checkbox"/>	<input checked="" type="checkbox"/>		

3. State why this vendor was selected to receive the award and contract:

WSP was selected for this contract based on an evaluation of their response to an RFQ.

Neil Kopper

Print/Type Name

Senior Project Engineer

Print/Type Title

Engineering

Department

**ADDENDUM TO AGREEMENT FOR CONSULTING SERVICES
FOR THE BLOOMINGTON NEIGHBORHOOD GREENWAYS
WITH WSP USA INC.**

This Addendum supplements the Agreement for Consulting Services with WSP USA Inc. (“Agreement”) for the Bloomington Neighborhood Greenways Project which was entered into on December 28, 2020, as follows:

1. **See Exhibit A Scope of Engineering Services:** Exhibit A provides a list of anticipated greenways projects. Exhibit A is hereby amended to add the Olive Street / Hillside Drive to Arden Drive / High Street greenway project.
2. In all other aspects, the Agreement shall remain in effect as originally written.

IN WITNESS WHEREOF, the parties have caused this Addendum to be executed on the day and year last written below.

OWNER

CONSULTANT

Kyla Cox Deckard
President, Board of Public Works

Pat McCallister
Indiana Local Business Leader

Elizabeth Karon
Vice President, Board of Public Works

Date: _____

James Roach
Secretary, Board of Public Works

Date: _____

Kerry Thomson
Mayor

Date: _____

EXHIBIT A
SCOPE OF ENGINEERING SERVICES

Scope of Services shall include:

Completion of all engineering tasks for multiple Phase 1 neighborhood greenway projects for one (1) or more of the following anticipated neighborhood greenways projects, as directed by the Board and as contained in a Task Order:

- (1) Weatherstone Lane (Hawthorne to Hillside);
- (2) Hawthorne (Weatherstone to 3rd);
- (3) Sheridan/Southdowns (Woodlawn to Jordan);
- (4) Southdowns./Ruby/Nancy (Jordan to High);
- (5) Covenanter (High to College Mall); and
- (6) Olive Street / Hillside Drive to Arden Drive / High Street

**ADDENDUM TO TASK ORDER NO. 1
FOR THE BLOOMINGTON NEIGHBORHOOD GREENWAYS TASK-ORDER BASED
PROFESSIONAL SERVICES AGREEMENT
WITH WSP USA INC.**

This Addendum supplements the Task Order No. 1 of the Agreement for Consulting Services with WSP USA Inc. (“Agreement”) for the Bloomington Neighborhood Greenways Project, as follows:

1. **See Exhibit 1 Scope of Services**: Exhibit 1 of the Task Order provides the scope of services. Exhibit 1 is hereby amended to add the Olive Street / Hillside Drive to Arden Drive / High Street greenway project.

2. In all other aspects, the Task Order Agreement shall remain in effect as originally written.

IN WITNESS WHEREOF, the parties have caused this Addendum to be executed on the day and year last written below.

OWNER

CONSULTANT

Kyla Cox Deckard
President, Board of Public Works

Pat McCallister
Indiana Local Business Leader

Elizabeth Karon
Vice President, Board of Public Works

Date: _____

James Roach
Secretary, Board of Public Works

Date: _____

Kerry Thomson
Mayor

Date: _____

EXHIBIT 1 - SCOPE OF WORK

Pre-Design Services

The City of Bloomington has requested that WSP USA Inc. (WSP) perform pre-design services for Neighborhood Greenways at up to six (6) locations in Bloomington, Indiana. The locations are assumed to be the following:

1. Weatherstone Lane - including crossing improvements at Hillside Drive and potential short trail connection to Hawthorne Drive.
2. Hawthorne Drive (from Weatherstone Lane to 3rd Street)
3. Sheridan Drive /Southdowns Drive (from Woodlawn Avenue to Jordan Avenue) -
4. Southdowns Drive, Ruby Lane, Nancy Street, and additional short neighborhood streets (from Jordan Avenue to High Street)
5. Covenanter Drive (from High Street to College Mall Road)
6. Olive Street / Hillside Drive to Arden Drive / High Street

WSP will be responsible for the following tasks as part of this Scope of Work:

Task 1. Project Management

Through its Quality Management System (QMS), WSP has a recognized project management and quality control system with an established series of tracking templates. It is through the QMS that WSP manages its projects, facilitating the team's adherence to project scope, schedule, and budget. WSP's project manager will comply with the QMS procedures by preparing a project management plan and associated documents to guide the project. Monthly invoices will be prepared for submittal to the City of Bloomington.

Task 2. Meetings

WSP will attend the following meetings in Bloomington, virtually or in person, for all 6 locations:

1. Input Meeting with City Staff (up to 2 WSP representatives)
2. Public Meeting #1 (up to 2 WSP representatives)
3. Alternative Review Meeting with City Staff (up to 2 WSP representatives)
4. Public Meeting #2 (up to 2 WSP representatives)

An initial input meeting will be scheduled with City Staff to determine City concerns and known issues for each project location, as well as any preliminary discussions on alternative solutions. At this meeting, criteria for analyzing and prioritizing alternatives will also be determined.

Public meeting #1 will be held to gather community input on the public perception of the issues at each location and solicit potential solutions the neighborhood would prefer. It is assumed that the City will plan and run the meeting; WSP will attend and offer support such as documenting community feedback (1 summary per location).

Once alternatives have been developed, WSP will schedule a meeting with City Staff to review the alternatives and refine them prior to the next public meeting.

Public meeting #2 will be held to present up to three (3) alternative solutions for each location to the public and retain their feedback. It is assumed that the City will plan and run the meeting; WSP will attend and offer support such as .pdf exhibits (1 per location), assisting with presentations (1 per location), and documenting community feedback (1 summary per location).

Deliverables: Meeting Minutes for all Meetings

Task 3. Alternative Development & Selection

To help develop alternative concepts for each location, WSP will conduct one (1) site visit per location, with up to two (2) WSP representatives attending. Based on the field conditions, as well as the input received from City Staff and Public Meeting #1, up to three (3) alternatives will be developed for each location. The alternatives could range from sign and pavement marking updates to curb line modifications. It is assumed that the City will provide guidance on the alternatives to consider for each location. For each alternative, a conceptual schematic and a preliminary planning level opinion of probable cost will be developed.

The alternatives will be evaluated and a list of pros and cons will be developed for each alternative. Public input for each will also be considered as part of this evaluation process. The list of pros and cons may include traffic capacity, benefit/cost analysis, safety considerations, expected compliance, ease of implementation, etc.

After the Alternative Review Meeting with City Staff, the alternatives will be modified as needed prior to Public Meeting #2. Based on the input received from City Staff and Public Meeting #2, a preferred alternative will be selected and refined.

A summary memorandum will be prepared for each location, documenting the process to select the preferred alternative. The memo will step through the existing conditions, need for the project, alternatives that were developed, input received from the City and the public, alternative analysis, and selection of the preferred alternative. A draft memorandum will be submitted for review and comment one time before finalizing the document.

Deliverables: 2D Conceptual Schematics, Preliminary Cost Estimates, Draft Summary Memos, Final Summary Memos (all in .pdf format)

Exclusions: Traffic Counts, Crash Analysis, Capacity Analysis

Assumptions: City of Bloomington to provide guidance on alternatives for consideration at each location.

Task 4. Planning (Optional)

If desired by the City, WSP can provide Planning services for this project. The WSP planning representative would attend the following with the other WSP representatives:

- Field visit
- Input meeting with City Staff
- Public Meeting #1
- Alternative Review Meeting with City Staff

The planning representative would be heavily involved in the development of the conceptual alternatives, instead of relying on the City of Bloomington planning department to specify the alternatives to consider at each location. Alternatives would be chosen based on safety and accessibility benefits, unless other priorities are established during the initial input meeting with the City.

Deliverables: Development of Alternatives (up to 3 per Location)



Board of Public Works Staff Report

Project/Event:	Clark Concrete Sidewalk Closure
Staff Representative:	Kyle Baugh
Petitioner/Representative:	Rodney Clark
Date:	March 21 st , 2024

Report: Clark Concrete is requesting a temporary sidewalk closure for the eastern sidewalk of N Grant St adjacent to Big Woods Brewery. This request is to accommodate approximately 150ft of sidewalk and curb removal and replacement along the property. The temporary traffic control would be in place from May 22nd, 2024 through May 24th, 2024.

Clark concrete has supplied maintenance of traffic plans for all work. They have also sent Public notice to property owners about the BPW meeting and scope of their work.

Recommendation and Supporting Justification: Staff has reviewed the request and recommends granting permission to Clark Concrete for the temporary traffic control temporarily close the Grant St eastern sidewalk.

Figure 6H-28. Sidewalk Detour or Diversion (TA-28)

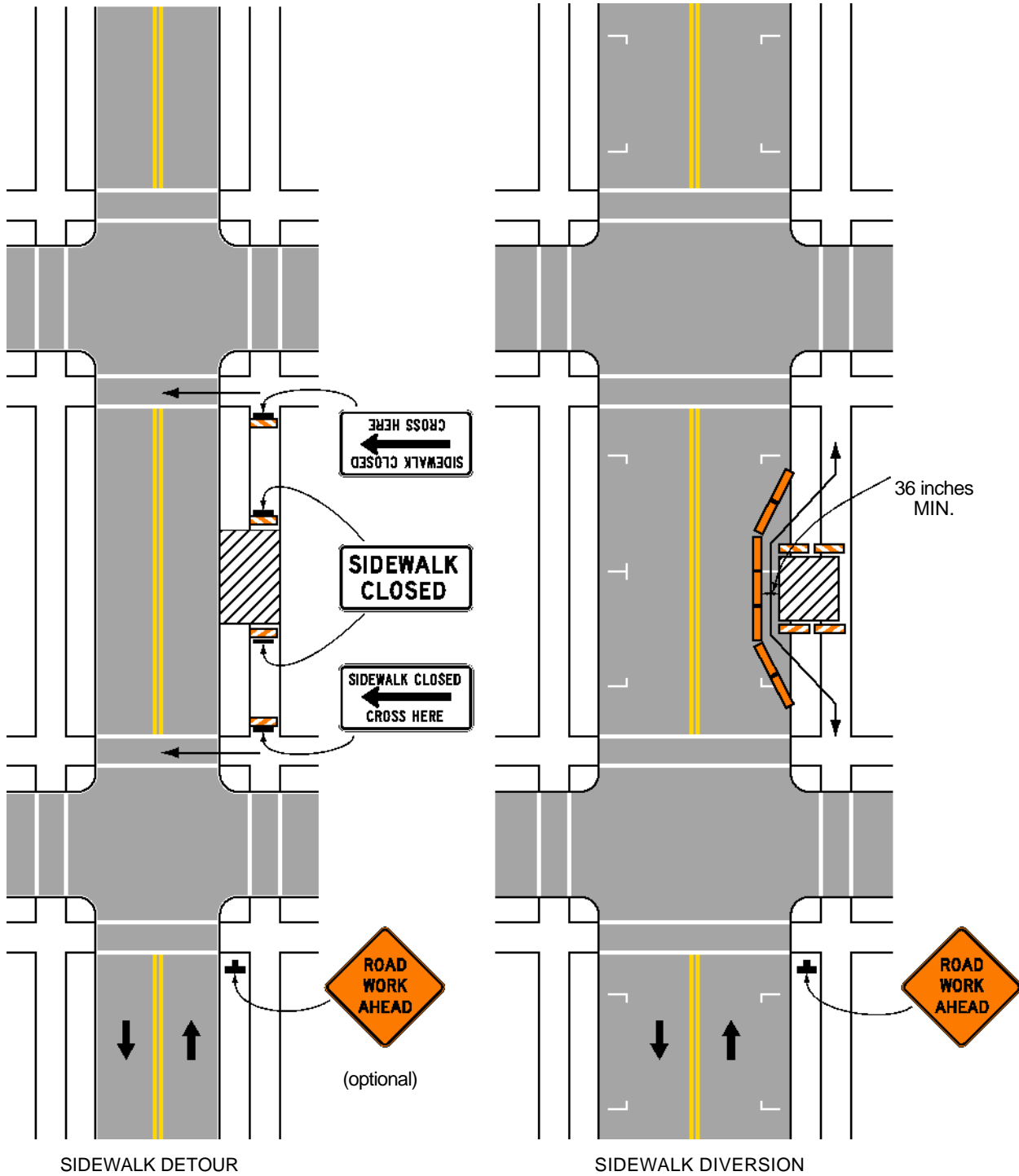

Typical Application 28

Note: See Tables 6H-2 and 6H-3 for the meaning of the symbols and/or letter codes used in this figure.



Feb 23, 2024

The City of Bloomington
P.O. Box 100
Bloomington, IN 47402

RECEIVED

MAR 05 2024

*City of Bloomington
Legal Department
Bloomington, Indiana*

Re: Project: Needmore to Unionville
Parcel No. T136-137 Parcel ID #: 53-08-09-400-006.000-009 & 53-08-10-300-045.000-009

Dear City of Bloomington:

I am a contract land agent for CenterPoint Energy and writing to you regarding your property in Bloomington IN

CenterPoint Energy is the local gas utility, and they need to upgrade sections of the existing gas line (see enclosed easement legal description). To perform the gas line upgrade, CenterPoint Energy requires a temporary easement for additional workspace.

I have attached a copy of the temporary easement document, easement valuation worksheet, assurance letter and W9 for your review. Please contact me at your earliest convenience via telephone/text at **317-590-5001** and or email at davehelton@heltonassoc.com.

I very much appreciate your time!

Sincerely,

Dave Helton

Dave Helton,
Authorized Land Agent for
CenterPoint Energy

106 Parkridge Drive
Danville, IN 46122
Cell (317) 590-5001
davehelton@heltonassoc.com

Project: Needmore to Unionville
Easement Valuation Worksheet

SAP#:	107093116
Tract:	T136-137

Permanent Easement	0	Acres
Temporary Easement	0.031	Acres

Name:	City of Bloomington
-------	---------------------

Contact Info:	PO Box 100, Bloomington, IN 47402
---------------	-----------------------------------

Property Address:	2120 S. Highland Ave Bloomington, IN 47403
-------------------	---

Easement Valuation

Assessed Land Value	5556700	X 1.25	Parcel Value/Acre:	\$138,667.90
Parcel Acreage	50.09			

Permanent Easement							
0	acres	X	\$0.00	X	0.00%	fee =	\$0.00

Temporary Easement							
0.031	acres	X	\$138,667.90	X	10.00%	fee =	\$429.87

Include Crop Damages?	No
-----------------------	----

Easement Value: \$429.87

Crop Damages: \$0.00

Minimum Easement Payment = \$500.00 **TOTAL: \$500.00**



CenterPoint Energy
600 Industrial Drive
Franklin, IN 46131-9616
(317) 736-2929

February 11, 2024

The City of Bloomington
P.O. Box 100
Bloomington, IN 47402

Re: Project: Needmore to Unionville
Parcel No. T136-137
Parcel ID #: 53-08-09-400-006.000-009 & 53-08-10-300-045.000-009

Dear City of Bloomington:

With reference to the current negotiations with Indiana Gas Company, Inc., an Indiana corporation doing business as CenterPoint Energy Indiana North ("CNP"), for a temporary easement on the above-referenced property, please be advised that CNP is tendering this letter to further specify and agree to the following:

1. CNP agrees to compensate the landowner a total sum of Five Hundred and 00/100 (\$500.00) Dollars for granting CNP a Temporary Easement on its property within 30 days of easement signing provided the landowner provides a verifiable IRS Form W-9 to CNP.
2. This Assurance Letter is contingent upon the landowner granting CNP a Temporary Easement across the landowner's property.

We trust this letter will be satisfactory to the City of Bloomington as an added assurance in granting CNP the temporary easement on its property.

Respectfully,

Dennis Burns

Dennis Burns
Senior Right of Way Agent
Land and Field Services
CenterPoint Energy

Project Name: Needmore to Unionville

Tract No. T136-137

SAP No. 107093116

TEMPORARY EASEMENT

THIS AGREEMENT WITNESSETH, THAT **The City of Bloomington, Indiana**, hereinafter called the "Grantor", for and in consideration of the sum of One Dollar (\$1.00) and other valuable consideration, receipt of which is hereby acknowledged, hereby grants and warrants to **INDIANA GAS COMPANY, INC., an Indiana corporation doing business as CENTERPOINT ENERGY INDIANA NORTH**, its successors and assigns, hereinafter collectively called the "Grantee", a Temporary Easement and right to use a tract of land described below and attached for access, work space, equipment and materials storage area, said land being situated in:

Part of the Southeast Quarter of Section 9 and part of the Southwest Quarter of Section 10, both in Township 8 North, Range 1 West, Perry Township, Monroe County, Indiana, and being a parcel conveyed to Grantor by Warranty Deed dated August 13, 1967, recorded as Instrument No. 06237, by Warranty Deed dated June 10, 1966, recorded as Instrument No. 92327, and by Warranty Deed dated April 6, 1965, and recorded as Instrument Number 92326, in the office of the Recorder of Monroe County, Indiana.

Parcel No. 53-08-09-400-006.000-009; 53-08-10-300-045.000-009

Said Temporary Easement area is more particularly shown on Exhibit "A" attached hereto and made a part hereof.

- 1) TO HAVE AND TO USE said Temporary Easement for access, work space, equipment and materials storage area located on Grantor's property as described above unto Grantee, unless this Temporary Easement shall be sooner terminated in a manner hereinafter provided, commencing on the below executed date, and continuing from month to month and terminating the 31 day of March, 2025.
- 2) Grantee shall have the right to ingress and egress over the land of Grantor to and from said Temporary Easement in the exercise of the rights herein granted, provided, that in the exercise of such rights the Grantee will, whenever practicable to do so, use existing highways, roadways or other access routes.
- 3) Grantee shall reimburse Grantor for any damage or loss to growing crops, soil, tile, gates and fences that may be caused by Grantee or its contractors while accessing or working in the Temporary Easement. Any such damages shall be paid or otherwise restored as nearly as can be to its original condition by Grantee, provided written notice thereof is given to Grantee at its Evansville office located at 211 NW Riverside Drive, Attn: Land and Field Services, Evansville, Indiana 47708, or such place as Grantee may designate, within ninety (90) days after the occurrence of such damage.
- 4) Grantee agrees that upon the termination of this Temporary Easement, by lapse of time or otherwise, Grantee will surrender said premises hereby demised to Grantor in as good condition and repair as when received by Grantee, ordinary wear and tear only expected. Grantee further agrees that no permanent facilities will be left within the Temporary Easement.

- 5) Grantor covenants and warrants that Grantor is the fee owner of the Temporary Easement area and has the right, title, and capacity to grant the Temporary Easement herein conveyed.

***Rest of page left intentionally blank**

IN WITNESS WHEREOF, this Agreement is executed this _____ day of _____, 2024.

Grantor: The City of Bloomington, Indiana

By: _____

Print: _____

Title: _____

STATE OF INDIANA, COUNTY OF _____, SS:

Before me, a Notary Public in and for said County and State, personally appeared _____
_____, the _____, of **The City of Bloomington, Indiana**, the Grantor, in the
foregoing Temporary Easement, and acknowledged the signing thereof to be of his voluntary act and deed. In testimony
thereof, I have hereunto set my hand and seal, this ____ day of _____, 2024.

Notary Public

(printed name)

My Commission expires _____ My County of Residence is _____

My Commission number is _____

Grantee's Tax Mailing Address: CenterPoint Energy, Attn: Land and Field Services, 211 NW Riverside Dr., Evansville, Indiana 47708. I affirm, under the penalties for perjury, that I have taken reasonable care to redact each Social Security Number in this document, unless required by law. Dennis Burns, Right of Way Agent, CenterPoint Energy. This instrument prepared by the Grantee named herein by Dennis Burns, CenterPoint Energy, 600 Industrial Drive, Franklin, Indiana 46131.

EASEMENT EXHIBIT "A"
PART OF SECTIONS 9 & 10, TOWNSHIP 8 NORTH, RANGE 1 WEST,
PERRY TOWNSHIP
MONROE COUNTY, INDIANA

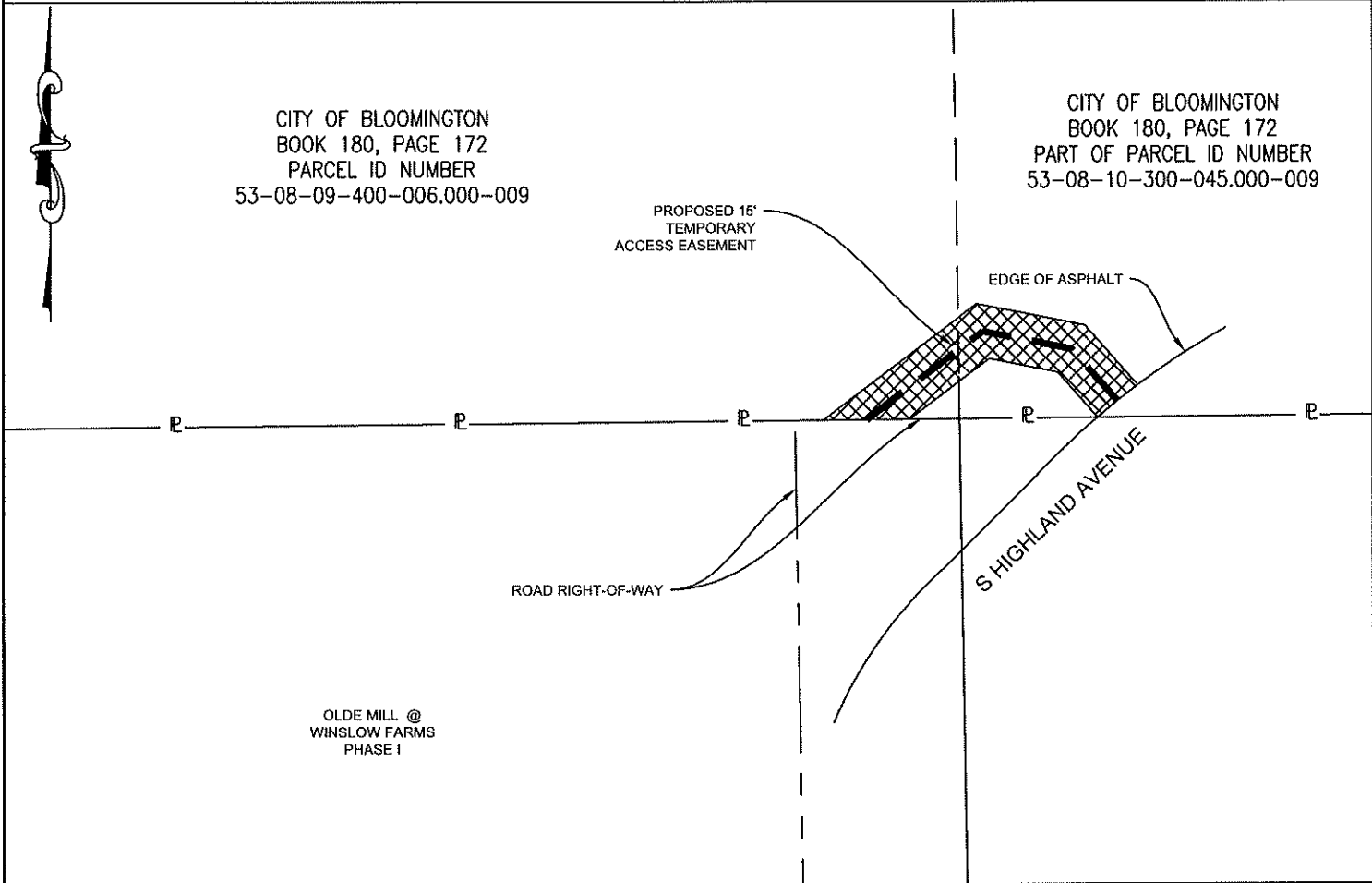

LEGEND

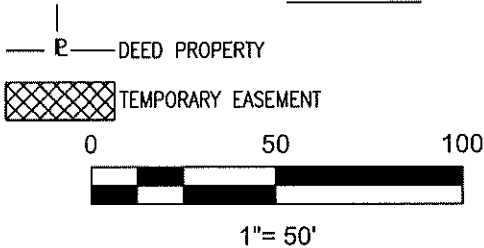

ALL BEARINGS AND DISTANCES SHOWN HEREON ARE BASED ON THE NRS 2011 STATE PLANE COORDINATE SYSTEM INDIANA WEST.

THIS EXHIBIT HAS BEEN PREPARED FOR THE SOLE PURPOSE OF ACQUIRING A TEMPORARY ACCESS & CONSTRUCTION EASEMENT AND DOES NOT REPRESENT A BOUNDARY SURVEY, NOR IS IT INTENDED FOR LAND TRANSFER.

AREA OF TEMPORARY EASEMENT = 0.031 ACRES
 1,335 SQ. FT.

SHEET 1 OF 1



CORPORATE OFFICE: 1055 WELLINGTON WAY
 SUITE 225
 LEXINGTON, KY 40513

TEL: (859) 873-0076 FAX: (859) 873-5872

www.ensiteusa.com

TRACT NO. 136 & 137

TEMPORARY EASEMENT
 ON THE PROPERTY OF

REV. 0 CITY OF BLOOMINGTON

PROJECT NAME				BIN NS5153 NEEDMORE TO UNIONVILLE		SAP W.O. # 107093116	
DRAWN	ARL	DATE	11/02/2023	NO.	0	REVISIONS DESCRIPTION	
CHK'D	TWB	DATE	11/02/2023	NO.	0	TEMPORARY EASEMENT	
ENSITEUSA JOB NO.		7604.5142					
DWG NO.		7604.5142-TWS136					

EASEMENT EXHIBIT "A"
PART OF SECTIONS 9 & 10, TOWNSHIP 8 NORTH, RANGE 1 WEST,
PERRY TOWNSHIP
MONROE COUNTY, INDIANA



LEGEND

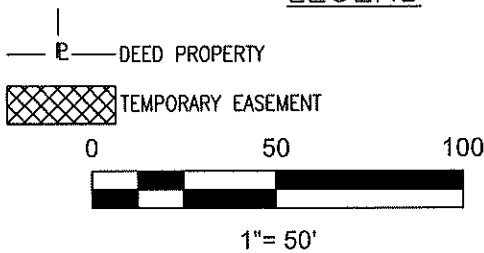

ALL BEARINGS AND DISTANCES SHOWN HEREON ARE BASED ON THE NRS 2011 STATE PLANE COORDINATE SYSTEM INDIANA WEST.

THIS EXHIBIT HAS BEEN PREPARED FOR THE SOLE PURPOSE OF ACQUIRING A TEMPORARY ACCESS & CONSTRUCTION EASEMENT AND DOES NOT REPRESENT A BOUNDARY SURVEY, NOR IS IT INTENDED FOR LAND TRANSFER.

SHEET 1 OF 1

AREA OF TEMPORARY EASEMENT = 0.031 ACRES
 1,335 SQ. FT.



CORPORATE OFFICE: 1055 WELLINGTON WAY
 SUITE 225
 LEXINGTON, KY 40513

TEL: (859) 873-0076 FAX: (859) 873-5872
www.ensiteusa.com

TRACT NO. 136 & 137

TEMPORARY EASEMENT
 ON THE PROPERTY OF

REV. 0 CITY OF BLOOMINGTON

PROJECT NAME 9IN NSS153 NEEDMORE TO UNIONVILLE				SAP W.O. # 107093116	
DRAWN	ARL	DATE	11/02/2023	NO.	DATE
CHK'D	TWB	DATE	11/02/2023	0	01/18/2024
ENSITEUSA JOB NO.		7604.5142		REVISIONS DESCRIPTION	
DWG NO.		7604.5142-TWS136		TEMPORARY EASEMENT	



Jan 28, 2024

City of Bloomington
Attn: Department of Public Works
P.O. Box 100 Bloomington, IN 47408

Re: Project: Dolan to IU
Parcel No. T06
Parcel ID #: 53-05-33-105-095.000-005

RECEIVED

FEB 06 2024

City of Bloomington
Legal Department
Bloomington, Indiana

Dear Public Works:

I am a contract land agent for CenterPoint Energy and writing to you regarding your property in Bloomington IN

CenterPoint Energy is the local gas utility, and they need to upgrade sections of the gas line (see enclosed easement legal description). To perform the gas line upgrade, CenterPoint Energy requires a temporary easement for additional workspace. The temporary easement will revert back to you per the temporary easement.

I have attached a copy of the temporary easement document along with an easement valuation worksheet for your review. Please contact me at your earliest convenience via telephone/text at **317-590-5001** and or email at davehelton@heltonassoc.com.

I very much appreciate your time!

Sincerely,

Dave Helton

Dave Helton,
Authorized Land Agent for
CenterPoint Energy

106 Parkridge Drive
Danville, IN 46122
Cell (317) 590-5001
davehelton@heltonassoc.com



CenterPoint Energy
600 Industrial Drive
Franklin, IN 46131-9616
(317) 736-2929

January 14, 2024

City of Bloomington
Attn: Department of Public Works
P.O. Box 100
Bloomington, IN 47408

Re: Project: Dolan to IU
Parcel No. T06
Parcel ID #: 53-05-33-105-095.000-005

Dear Public Works:

With reference to the current negotiations with Indiana Gas Company, Inc., an Indiana corporation doing business as CenterPoint Energy Indiana North ("CNP"), for a temporary easement on the above-referenced property, please be advised that CNP is tendering this letter to further specify and agree to the following:

1. Compensation for easement in the amount of Thirteen Thousand Sixty-Eight and 18/100 (\$13,068.18) Dollars payable within twenty (20) days of executing the subject easement and providing an IRS Form W-9.

We trust this letter will be satisfactory to you as an added assurance in you granting CNP the temporary easement on your property.

Sincerely,

Dennis Burns

Dennis Burns
Senior Right of Way Agent
Land and Field Services
CenterPoint Energy

Project: Dolan to IU

Easement Valuation Worksheet

SAP#:	107093116
Parcel:	T06

Permanent Easement	0	Acres
Temporary Easement	0.08	Acres

Name:	City of Bloomington
-------	---------------------

Contact Info:	P.O. Box 100, Bloomington, IN 47402
---------------	-------------------------------------

Property Address:	810 N. Woodlawn Ave Bloomington, IN 47408
-------------------	--

Easement Valuation

Assessed Land Value	1092500
Parcel Acreage	0.836

x 1.25

Parcel Value/Acre:	\$1,633,522.73
--------------------	----------------

Permanent Easement							
0	acres	X	\$0.00	X	0.00%	fee =	\$0.00

Temporary Easement							
0.08	acres	X	\$1,633,522.73	X	10.00%	fee =	\$13,068.18

Include Crop Damages?	No
-----------------------	----

Easement Value: \$13,068.18

Crop Damages: \$0.00

TOTAL: \$13,068.18

Project Name: Dolan to IU

Tract No. T06

SAP No. 107093116

TEMPORARY EASEMENT

THIS AGREEMENT WITNESSETH, THAT the **City of Bloomington**, hereinafter called the "Grantor", for and in consideration of the sum of One Dollar (\$1.00) and other valuable consideration, receipt of which is hereby acknowledged, hereby grants and warrants to **INDIANA GAS COMPANY, INC., an Indiana corporation doing business as CENTERPOINT ENERGY INDIANA NORTH**, its successors and assigns, hereinafter collectively called the "Grantee", a Temporary Easement and right to use a tract of land described below and attached for access, work space, equipment and materials storage area, said land being situated in:

Bloomington Township, Monroe County, located in University Park Addition to the City of Bloomington, Indiana, as set out in Plat Cabinet "B", Envelope 24, and being the same tract of land conveyed to Grantor by Trustees' Deed dated April 8th, 1963, and recorded in Deed Book 150, Pages 521-522, in the office of the Recorder of Monroe County, Indiana.

Parcel No. 53-05-33-105-095.000-005

Said Temporary Easement area is more particularly shown on Exhibit "A" attached hereto and made a part hereof.

- 1) TO HAVE AND TO USE said Temporary Easement for access, work space, equipment and materials storage area located on Grantor's property as described above unto Grantee, unless this Temporary Easement shall be sooner terminated in a manner hereinafter provided, commencing on the below executed date, and continuing from month to month and terminating the 31 day of January, 2025.
- 2) Grantee shall have the right to ingress and egress over the land of Grantor to and from said Temporary Easement in the exercise of the rights herein granted, provided, that in the exercise of such rights the Grantee will, whenever practicable to do so, use existing highways, roadways or other access routes.
- 3) Grantee shall reimburse Grantor for any damage or loss to growing crops, soil, tile, gates and fences that may be caused by Grantee or its contractors while accessing or working in the Temporary Easement. Any such damages shall be paid or otherwise restored as nearly as can be to its original condition by Grantee, provided written notice thereof is given to Grantee at its Evansville office located at 211 NW Riverside Drive, Attn: Land and Field Services, Evansville, Indiana 47708, or such place as Grantee may designate, within ninety (90) days after the occurrence of such damage.
- 4) Grantee agrees that upon the termination of this Temporary Easement, by lapse of time or otherwise, Grantee will surrender said premises hereby demised to Grantor in as good condition and repair as when received by Grantee, ordinary wear and tear only expected. Grantee further agrees that no permanent facilities will be left within the Temporary Easement.

- 5) Grantor covenants and warrants that Grantor is the fee owner of the Temporary Easement area and has the right, title, and capacity to grant the Temporary Easement herein conveyed.

***Rest of page left intentionally blank**

IN WITNESS WHEREOF, this Agreement is executed this _____ day of _____, 2024.

Grantor: City of Bloomington

By: _____

Print: _____

Title: _____

STATE OF INDIANA, COUNTY OF _____, SS:

Before me, a Notary Public in and for said County and State, personally appeared _____, the _____, of the **City of Bloomington**, the Grantor, in the foregoing Temporary Easement, and acknowledged the signing thereof to be of his/her voluntary act and deed. In testimony thereof, I have hereunto set my hand and seal, this ____ day of _____, 2024.

Notary Public

(printed name)

My Commission expires _____ My County of Residence is _____

My Commission number is _____

Grantee's Tax Mailing Address: CenterPoint Energy, Attn: Land and Field Services, 211 NW Riverside Dr., Evansville, Indiana 47708.

I affirm, under the penalties for perjury, that I have taken reasonable care to redact each Social Security Number in this document, unless required by law. Dennis Burns, Right of Way Agent, CenterPoint Energy.

This instrument prepared by the Grantee named herein by Dennis Burns,
CenterPoint Energy, 600 Industrial Drive, Franklin, Indiana 46131.

EASEMENT EXHIBIT "A"

PART OF SECTION 33, TOWNSHIP 9 NORTH, RANGE 1 WEST, BLOOMINGTON TOWNSHIP MONROE COUNTY, INDIANA

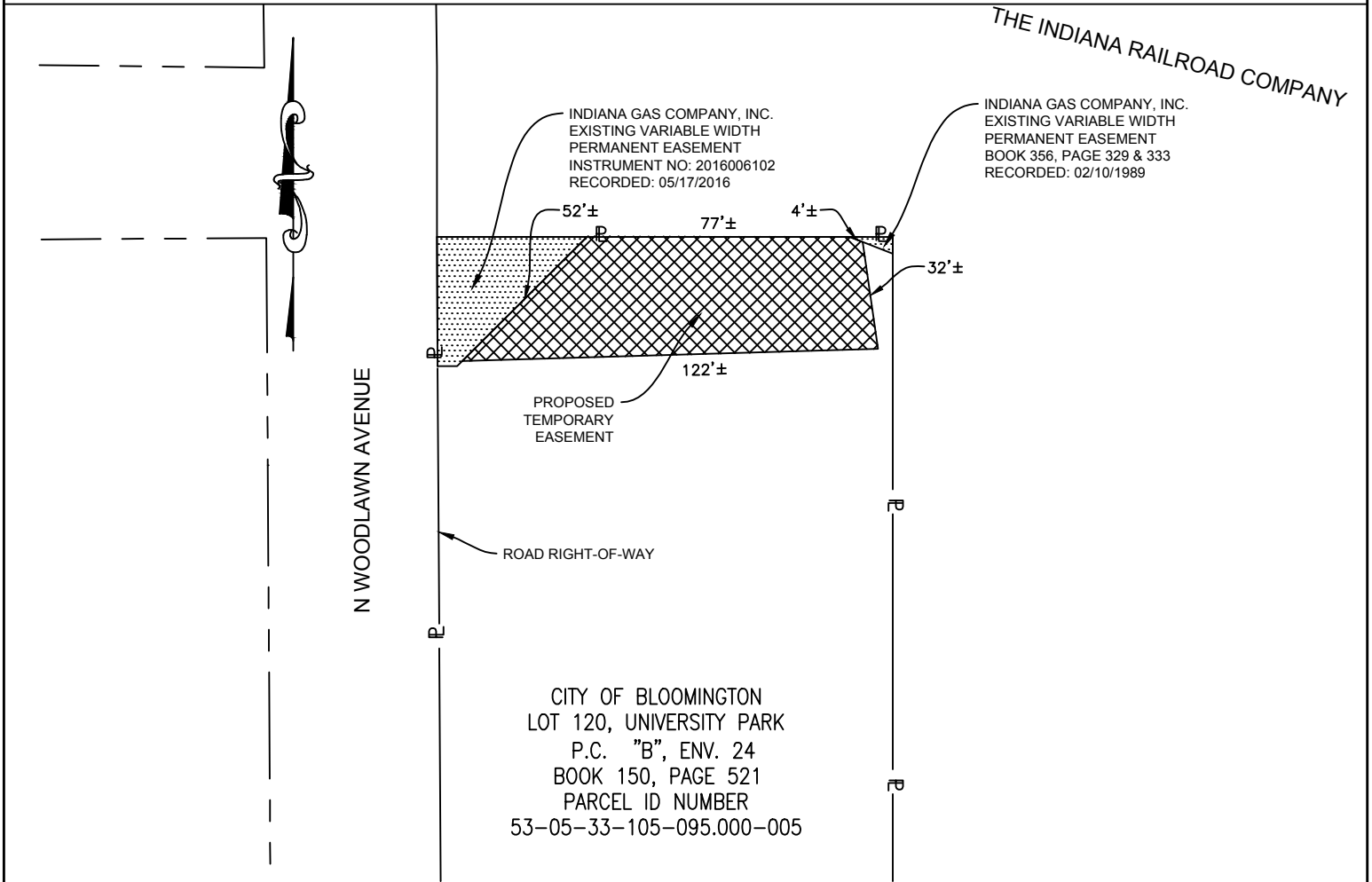

LEGEND

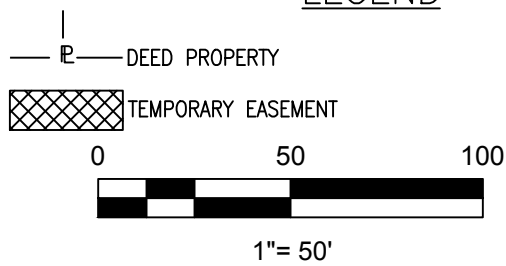

SHEET 1 OF 1

ALL BEARINGS AND DISTANCES SHOWN HEREON ARE BASED ON THE NAD 83 (2011) STATE PLANE COORDINATE SYSTEM INDIANA WEST.

THIS EXHIBIT HAS BEEN PREPARED FOR THE SOLE PURPOSE OF ACQUIRING A TEMPORARY ACCESS & CONSTRUCTION EASEMENT AND DOES NOT REPRESENT A BOUNDARY SURVEY, NOR IS IT INTENDED FOR LAND TRANSFER.

AREA OF TEMPORARY EASEMENT = 0.08 ACRES
3,478 SQ. FT.



CORPORATE OFFICE: 1055 WELLINGTON WAY
SUITE 225
LEXINGTON, KY 40513
TEL: (859) 873-0076 FAX: (859) 873-5872
www.ensiteusa.com

TRACT NO. 06

TEMPORARY EASEMENT
ON THE PROPERTY OF

REV. 1 TRUSTEES OF INDIANA UNIVERSITY

PROJECT NAME		8IN NS5059 DOLAN TO IU		SAP W.O. # 107093115	
DRAWN	ARL	DATE	10/31/2023	NO.	DATE
CHK'D	TWB	DATE	10/31/2023	0	10/31/2023
ENSITEUSA JOB NO.	7604.5050		1	12/27/2023	ADDED RECORDING INFORMATION FOR EXISTING EASEMENTS
DWG NO.	7604.5050-TWS06				

EASEMENT EXHIBIT "A"

PART OF SECTION 33, TOWNSHIP 9 NORTH, RANGE 1 WEST, BLOOMINGTON TOWNSHIP MONROE COUNTY, INDIANA

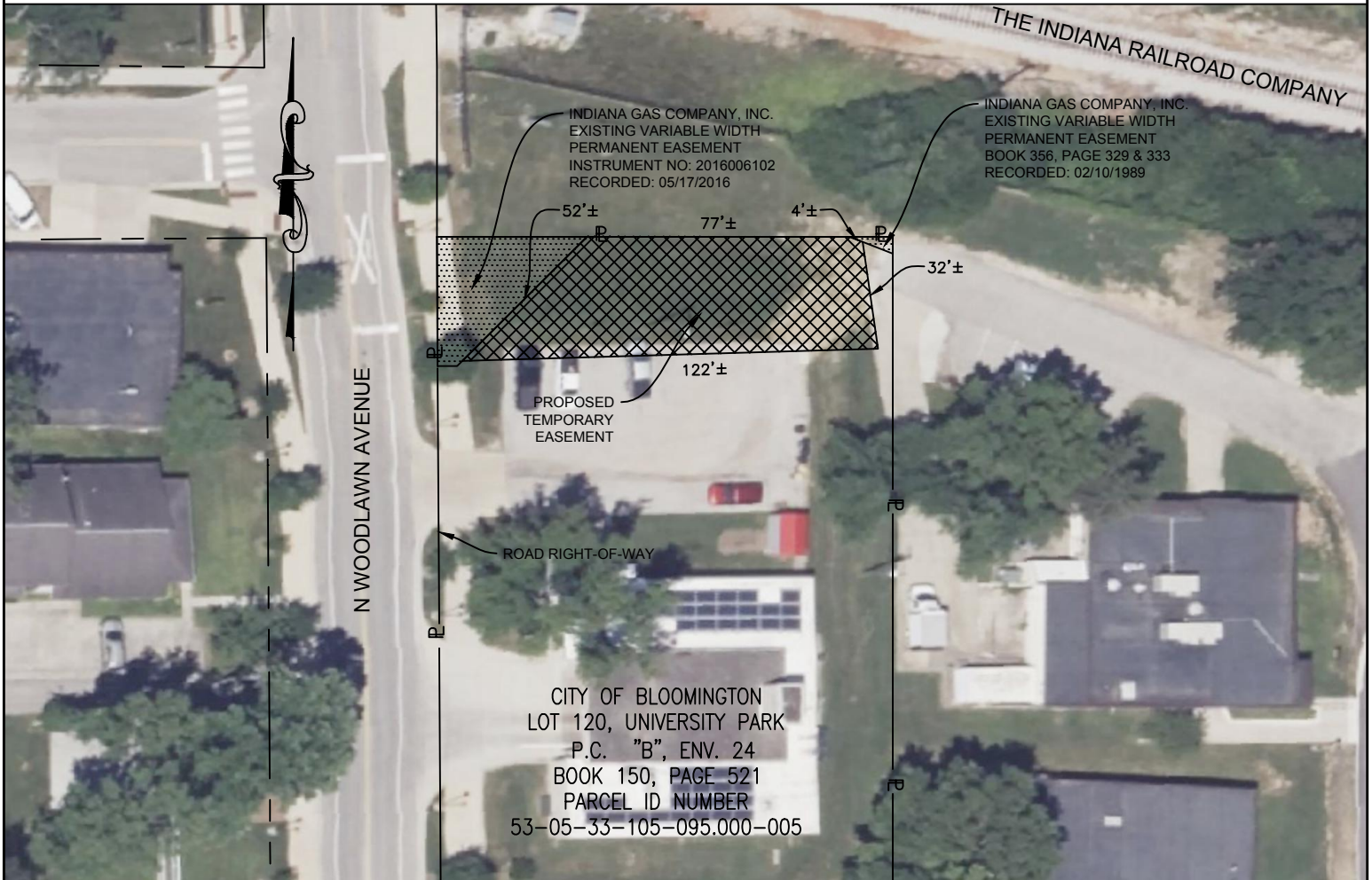

LEGEND

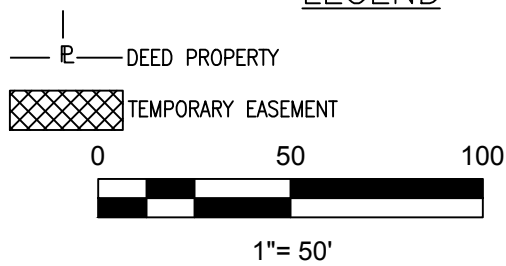

SHEET 1 OF 1

ALL BEARINGS AND DISTANCES SHOWN HEREON ARE BASED ON THE NAD 83 (2011) STATE PLANE COORDINATE SYSTEM INDIANA WEST.

THIS EXHIBIT HAS BEEN PREPARED FOR THE SOLE PURPOSE OF ACQUIRING A TEMPORARY ACCESS & CONSTRUCTION EASEMENT AND DOES NOT REPRESENT A BOUNDARY SURVEY, NOR IS IT INTENDED FOR LAND TRANSFER.

AREA OF TEMPORARY EASEMENT = 0.08 ACRES
3,478 SQ. FT.



CORPORATE OFFICE: 1055 WELLINGTON WAY
SUITE 225
LEXINGTON, KY 40513
TEL: (859) 873-0076 FAX: (859) 873-5872
www.ensiteusa.com

TRACT NO. 06

TEMPORARY EASEMENT
ON THE PROPERTY OF

REV. 1 TRUSTEES OF INDIANA UNIVERSITY

PROJECT NAME		8IN NS5059 DOLAN TO IU		SAP W.O. # 107093115	
DRAWN	ARL	DATE	10/31/2023	NO.	DATE
CHK'D	TWB	DATE	10/31/2023	0	10/31/2023
ENSITEUSA JOB NO.	7604.5050		1	12/27/2023	
DWG NO.	7604.5050-TWS06				
REVISIONS DESCRIPTION					
TEMPORARY EASEMENT					
ADDED RECORDING INFORMATION FOR EXISTING EASEMENTS					



Board of Public Works Staff Report

Project/Event: Renewal #1 for De-icing Salt Contract with Cargill, Inc.
Petitioner/Representative: Street Department
Staff Representative: Joe VanDeventer
Meeting Date: May 21, 2024

Per the 2023 contract agreement with Cargill, Inc. both parties have agreed to extend our contract on same terms and conditions for 2024. The results are as follows

Cargill, Inc.

8,000 Tons \$ 95.76 \$ 766,080.00 +/-

City of Bloomington Contract and Purchase Justification Form

Vendor: Cargill, Inc.

Contract Amount: \$ 766,080.00 +/-

This form should be completed and attached to the contract documents and forwarded to the Legal Department Attorney assigned to your Department. Contracts will not be approved by the Controller if a completed form is not included with the contract documents.

PURCHASE INFORMATION

1. Check the box beside the procurement method used to initiate this procurement: (Attach a quote or bid tabulation if applicable)

<input type="checkbox"/> Request for Quote (RFQ)	<input type="checkbox"/> Request for Proposal (RFP)	<input type="checkbox"/> Sole Source	<input checked="" type="checkbox"/> Not Applicable (NA)
<input type="checkbox"/> Invitation to Bid (ITB)	<input type="checkbox"/> Request for Qualifications (RFQu)	<input type="checkbox"/> Emergency Purchase	

2. List the results of procurement process. Give further explanation where requested. Yes No

# of Submittals: 3	Yes	No	Was the lowest cost selected? (If no, please state below why it was not.)	Yes	No
Met city requirements?	<input checked="" type="checkbox"/>	<input type="checkbox"/>	BPW awarded contract to Cargill, Inc. on March 14, 2023 with renewal language.	<input checked="" type="checkbox"/>	<input type="checkbox"/>
Met item or need requirements?	<input checked="" type="checkbox"/>	<input type="checkbox"/>			
Was an evaluation team used?	<input type="checkbox"/>	<input checked="" type="checkbox"/>			
Was scoring grid used?	<input type="checkbox"/>	<input checked="" type="checkbox"/>			
Were vendor presentations requested?	<input type="checkbox"/>	<input checked="" type="checkbox"/>			

3. State why this vendor was selected to receive the award and contract:

On March 14, 2023 the Board of Public Works approved the 2023 Agreement with Cargill, Inc. to provide de-icing salt. This Renewal #1 supplements that contract with Cargill, Inc. for 2024 as agreed by both City and Cargill, Inc.

Joe VanDeventer

Director of Operations

PW/Street

Print/Type Name

Print/Type Title

Department



24950 Country Club Blvd, Suite 450
North Olmsted, OH 44070

May 7, 2024

Danna Workman
Asset Clerk/Emergency Grant Coordinator
Public Works- Street Division
1981 S Henderson
Bloomington IN 47401
workmand@bloomington.in.gov

Dear Ms. Workman

This letter is being submitted to you to request a renewal of our current standing contract for the 2024/2025 winter season. We value the relationship Cargill has had with the City of Bloomington. We are planning our capabilities to meet the demand that winter requires to keep people safe and commerce moving. Cargill is truly invested in the City of Bloomington’s winter safety. Cargill Road Safety wants to make sure we continue to meet your needs by providing deicing products that help save lives, enhance commerce, and limit environmental impact.

The agreement would be a continuation of the original terms and price listed on the 2023/2024 bid documents. To further service the City of Bloomington better, we are requesting you to provide an estimate for usage for the 2024/2025 season.

2024/2025 Price for ClearLane® Treated Salt Delivered: \$95.76 Per ton
2024/2025 Price for ClearLane® Treated Salt FOB: \$95.00 Per ton

We look forward to your approval of the above request by Tuesday, May 21st. If you have any questions, please let me know. Thank you in advance for your consideration of this request.

Sincerely,

Amanda Knaus

Amanda Knaus
District Manager
Cargill Inc.- Salt, Road Safety
Amanda_Knaus@cargill.com
Direct; (440)590-6518

AUTHORIZED SIGNATURE agreeing to the above notation:

NAME and TITLE: _____

SIGNATURE: _____ **DATE:** _____

The information in this Certification should be treated as strictly confidential as it reflects Cargill’s proprietary information and business trade secrets.

RENEWAL #1 TO DEICING MATERIALS CONTRACT
between the
CITY OF BLOOMINGTON
and
CARGILL, INC.

This Addendum supplements the Agreement for Purchase and Delivery of Deicing Salt with Cargill, Inc., ("Agreement") as follows:

1. On March 14, 2023, the Board of Public Works awarded the deicing materials contract based upon Cargill, Inc. bid for those materials. Renewal of this Agreement for two (2) consecutive one year terms is allowed. Cargill, Inc. has informed the City that it is willing to renew the 2023 contract for an additional year (First Renewal) and will provide deicing materials at the prices contained in its 2023 bid. The City and Cargill, Inc. agree to a one (1) year renewal of the Agreement, which shall commence on the date of award and shall continue through April 1, 2025.

2. In all other respects, the Agreement shall remain in effect as originally written.

IN WITNESS WHEREOF, the parties have caused this Addendum to be executed the day and year last written below:

CITY OF BLOOMINGTON

CARGILL, INC.

By: _____
Kyla Cox Deckard, President
Board of Public Works

By: _____

Name and Title

Date: _____

Date: _____

By: _____
Adam Wason, Director
Public Works Department

Date: _____

By: _____
Margie Rice, Corporation Counsel

Date: _____



Board of Public Works Staff Report

Project/Event: Award bid for De-icing Salt

Petitioner/Representative: Street Department

Staff Representative: Joe VanDeventer

Meeting Date: March 14, 2023

A review of the 2023 De-icing Salt bids has been conducted to determine the most responsible and responsive action to be recommended based upon the past usage of de-icing materials by the City of Bloomington Public Works Department.

Cargill, Inc.

8,000 Tons	\$ 95.76	\$ 766,080.00 +/-
------------	----------	-------------------

Morton Salt – declined to bid

Compass Mineral – declined to bid

City of Bloomington Contract and Purchase Justification Form

Vendor: Cargill, Inc.

Contract Amount: \$766,080.00

This form should be completed and attached to the contract documents and forwarded to the Legal Department Attorney assigned to your Department. Contracts will not be approved by the Controller if a completed form is not included with the contract documents.

PURCHASE INFORMATION

1. Check the box beside the procurement method used to initiate this procurement: (Attach a quote or bid tabulation if applicable)

<input type="checkbox"/> Request for Quote (RFQ)	<input type="checkbox"/> Request for Proposal (RFP)	<input type="checkbox"/> Sole Source	<input type="checkbox"/> Not Applicable (NA)
<input checked="" type="checkbox"/> Invitation to Bid (ITB)	<input type="checkbox"/> Request for Qualifications (RFQu)	<input type="checkbox"/> Emergency Purchase	

2. List the results of procurement process. Give further explanation where requested. Yes No

# of Submittals: 3	Yes	No	
Met city requirements?	<input checked="" type="checkbox"/>	<input type="checkbox"/>	Was the lowest cost selected? (If no, please state below why it was not.) <input checked="" type="checkbox"/> Yes <input type="checkbox"/> No Bids opened at Board of Public work session on 3/13/23.
Met item or need requirements?	<input checked="" type="checkbox"/>	<input type="checkbox"/>	
Was an evaluation team used?	<input type="checkbox"/>	<input checked="" type="checkbox"/>	
Was scoring grid used?	<input type="checkbox"/>	<input checked="" type="checkbox"/>	
Were vendor presentations requested?	<input type="checkbox"/>	<input checked="" type="checkbox"/>	

3. State why this vendor was selected to receive the award and contract:

Bids were conducted, Cargill, Inc. was determined the most responsible and responsive, action to recommend upon the past usage of de-icing salt by the City of Bloomington Public Works/Street Division.

Joe VanDeventer

Director of Operations

PW/Street Division

Print/Type Name

Print/Type Title

Department

Is this product on the Pacific Northwest States (PNS) Approved List? Yes No

Certification: By signature affixed below, I hereby certify the above information to be complete and accurate and further certify that the product described meets or exceeds all additional specification requirements applicable to this offering. I further certify that any product delivered under the product name shown on this sheet will meet or exceed all applicable specification requirements and be equal or better in quality to the product described on this sheet.

Signed:  Date: 03.09.2023

Printed Name: Tatyana Huhn Title: Customer Care Representative

Bidder Cargill, Incorporated-Salt, Road Safety
--

VENDOR CERTIFIED PRODUCT DATA SHEET –Granular Sodium Chloride

Complete all fields listed below: Additional attachments will not be accepted in lieu of this data sheet.

Product Name (Brand Name): ClearLane Enhanced Deicer

Manufacturer's Name: Cargill, Incorporated-Salt, Road Safety

Manufacturer's Address: 24950 Country Club Blvd, Ste 450 North Olmsted, OH 44070

CERTIFIED SIZE GRADING:

Material	Content, % (w/w)
NaCl	97.3%
Water (Moisture)	0.02%
<u>Sieve Size</u>	<u>Percent Passing</u>
1/2" - (12.5 MM)	100%
3/8" - (9.5 MM)	95-100%
No. 4 - (4.75 MM)	20-90%
No. 8 - (2.36 MM)	10-60%
No. 30 - (600 Microns)	15 % Max

Certification: By signature affixed below, I hereby certify the above information to be complete and accurate and further certify that the product described meets or exceeds all additional specification requirements applicable to this offering. I further certify that any product delivered under the product name shown on this sheet will meet or exceed all applicable

specification requirements and be equal or better in quality to the product described on this sheet.

Signed: Tatyana Huhn Date: 03.09.2023

PrintedName: Tatyana Huhn Title: Customer Care Representative

BID OFFER FOR SODIUM CHLORIDE WITH LIQUID MAGNESIUM CITY OF BLOOMINGTON, INDIANA 2023-2024

Unit Price per Ton (Delivered) \$ 95.76

Unit Price per Ton (FOB) \$ 95.00

Total Bid Amount (Delivered) \$ 766,080.00 8,000 Tons (More or Less)

Total Bid Amount (FOB) \$ 760,000.00 8,000 Tons (More or Less)

Please state any conditions that are not part of specifications below or by attachment:

SPECIAL PROVISIONS TO THE BID

Delivery and Inspection

The City of Bloomington normally orders between 300 and 1,000 tons at a time. The enhanced salt must be delivered within 48 hours of placement of order. Weekends and holidays will not be counted in the 48 hour time period. All deliveries will be made in tarp covered trucks to 1981 S. Henderson Street, Bloomington, Indiana 47401. Deliveries are accepted Monday through Thursday between 7:00 a.m. local time, and 4:00 p.m. local time. For each working day that delivery extends beyond this 48 hour limit, \$200.00 will be deducted from any money due to the vendor, not as a penalty, but as liquidated damages. A email confirmation will be sent from the vendor to the City of Bloomington Street Department after each order is placed. The Street Department email confirmation is workmand@bloomington.in.gov.

Requirements for Loading

All material must be unloaded in the salt dome at 1981 S. Henderson Street. Failure to unload all the enhanced salt from the trucks into the storage building will result in a deduction, as liquidated damages from the price bid for salt delivered and loaded. Liquidated damages shall be the bid per ton cost plus \$1.00 per ton.

The deduction for liquidated damages shall not be made if the Department requires the material to be unloaded outside of the storage building. Such a departmental order shall be the only reason for not deducting liquidated damages for salt not unloaded into the salt storage dome structure. Salt shall not be unloaded on the ground or outside of the salt storage dome without specific order of the Street Department management. The vendor will be responsible for any damage to the salt dome resulting from improper piling or unloading of material. Further, the vendor may be required to move any material improperly stacked. The City of Bloomington reserves the right and privilege to require any truck to go to the nearest available certified scales to check weights at no additional cost to the City of Bloomington Street Department.

Delivery Tickets

Delivery tickets for all deliveries shall indicate gross, tare and net weights, the location of stockpile from which shipment is made and point of delivery. Weights will be checked at random for the accuracy of the delivery ticket weights. The City of Bloomington reserves the right and privilege to require any truck to go to the nearest available certified scales to check weights at no additional cost to the City of Bloomington Street Department.

1. **“Loaded”** to indicate materials were placed in the building. **The delivery tickets shall be marked as follows:**
2. **“Delivered”** will indicate that material delivered but not in the building which will result in the deduction for liquidated damages. **“Delivered”** represents that the load was dumped outside the building without permission.
3. **“Delivered – No Deduction”** – dumped with permission outside of the building – full payment to be made.

Invoicing

The vendor shall invoice the City of Bloomington Street Department by way of an itemized invoice within five (5) days after each delivery made by the vendor. Payment shall be made in arrears in accordance with Indiana law.

Bid Bond

A Bid Bond in the amount of 5% of bid amount shall be required with all bids. The Bid Bond will be held for liquidated damages if the bid is withdrawn before the award is made.

Failure to Meet Obligations

If the vendor is unable to meet its agreement obligations as set out in the invitation and specifications, then the City of Bloomington, at its option may purchase materials from the other available sources on the open market, may cancel the agreement or applicable portions thereof, and may award the portions so canceled to another supplier. In the event the City of Bloomington must resort to any of the above procedures, the vendor shall be required to reimburse the City of Bloomington for any expense incurred due to non-compliance with the terms of these specifications and special provisions.

BID, OFFER OR PROPOSAL FOR SALE OR LEASE OF MATERIALS

Granular Sodium Chloride Treated with Liquid Magnesium Chloride and Untreated Sodium Chloride

(PLEASE TYPE OR PRINT MATERIAL NAME)

03.09.2023

(DATE)

- 1. Governmental Unit: City of Bloomington Board of Public Works
- 2. County: Monroe
- 3. Bidder (Firm): Cargill, Incorporated-Salt, Road Safety
 Address: 24950 Country Club Blvd, Ste 450
- City/State/Zip: North Olmsted, OH 44070
- 4. Telephone Number: 800-600-7258
- 5. Agent of Bidder (if applicable): Customer Care

Pursuant to notices given, the undersigned offers bid(s) City of Bloomington Board of Public Works. In Accordance with the following attachment(s) which specify the class or item number or description, quantity, unit price and total amount.

The Contract will be awarded by classes or items, in accordance with specifications. Any changes or alterations in the items specified will render such bid void as to that class or item. Bidder promises that he/she has not offered nor received a less price than that price stated in his/her bid for the materials included in said bid. Bidder further agrees that he/she will not withdraw his/her bid from the office in which it is filed. A certified check or bond will be filed with each bid if required, and liability for breach shall be enforceable upon the contract, the bond or certified check or both as case may be.

Tatyana Huhn
PRINTED NAME

Tatyana Huhn
SIGNATURE OF BIDDER OR AGENT

BID OFFER OR PROPOSAL

Attach separate sheet listing each item bid based on specifications published by governing body. The following is an example of this bid format: CLASS OR ITEM QUANTITY UNIT DESCRIPTION UNIT PRICE AMOUNT

NON-COLLUSION AFFIDAVIT

STATE OF Ohio)
) SS:
COUNTY OF Cuyahoga)

The undersigned bidder or agent, being duly sworn on oath, says that he/she has not, nor has any other member, representative, or agent of the firm, company, corporation or partnership representative represented by him/her, entered into any combination, collusion or agreement with any person relative to the price to be bid by anyone at such letting nor to prevent any person from bidding nor to induce anyone to refrain from bidding, and that this bid is made without reference to any other bid and without any agreement, understanding or combination with any other person in reference to such bidding.

He/She further says that no person or persons, firms, or corporation has, have or will receive directly or indirectly, any rebate, fee, gift, commission or thing of value on account of such sale.

Cargill, Incorporated-Salt, Road Safety
BIDDER (FIRM)

Tatyana Huhn
PRINTED NAME

Tatyana Huhn
SIGNATURE OF BIDDER OR AGENT

Subscribed and sworn to me this day of 9th March 2023

My Commission Expires: 12/27/2025 Shelly Brown
Notary Public Signature

County of Residence: Butler Shelly Brown
Printed Name

My Commission Number: 1192549



ACCEPTANCE

There now being sufficient unobligated appropriated funds available, the contracting authority of City of Bloomington Board of Public Works hereby accepts the terms of the attached bid for classes or items numbered and promises to pay the undersigned bidder upon delivery of the price quoted for the materials stipulated in said bid.

BOARD OF PUBLIC WORKS MEMBERS:

[Signature]
ELIZABETH KARON MEMBER

[Signature]
KYLA COX DECKARD PRESIDENT
[Signature]
JENNIFER LLOYD, MEMBER

STATE OF Ohio)
) SS:
COUNTY OF Cuyahoga)

AFFIDAVIT REGARDING E-VERIFY

The undersigned, being duly sworn, hereby affirms and says that:

1. The undersigned is the Customer Care Representative of Cargill, Incorporated-Salt, Road Safety.
(job title) (company name)
2. The company named herein that employs the undersigned has contracted with or is seeking to contract with the City of Bloomington to provide services.
3. The undersigned hereby states that, to the best of his/her knowledge and belief, the company named herein does not knowingly employ an "unauthorized alien," as defined at 8 United States Code 1324a(h)(3).
4. The undersigned hereby states that, to the best of his/her knowledge and belief, the company named herein is enrolled in and participates in the E-verify program.

Tatyana Huhn Signature
Tatyana Huhn Printed Name

STATE OF Ohio)
) SS:
COUNTY OF Cuyahoga)

Before me, a Notary Public in and for said County and State, personally appeared Tatyana Huhn and

acknowledged the execution of the foregoing this

9th day of March, 2023.



Shelly Brown
Notary Public
Shelly Brown
Printed Name

My Commission Expires: 12/27/2025
County of Residence: Butler
My Commission Number: 1192549



**City of Bloomington
Human Rights Commission**

TO: BPW
DATE: March 10, 2023
RE BIDS FOR: Salt Bid
DEADLINE: March 10, 2023

Dear Board Members:

I have reviewed the affirmative action plan for Cargill Salts Inc., which is on file with the City Legal Department. I find the plan acceptable under the City of Bloomington Human Rights Ordinance and under the Contract Compliance Regulations. I will retain a copy of the plan in my files.

Sincerely,

A handwritten signature in cursive script that reads "Audrey Brittingham".

Audrey Brittingham
Assistant City Attorney

Cc: File
Bidder

REGISTER OF PAYROLL CLAIMS
Board: Board of Public Works Claim Register

Date:	Type of Claim	FUND	Description	Bank Transfer	Amount
5/17/2024	Payroll				580,214.47
					<u>580,214.47</u>

ALLOWANCE OF CLAIMS

We have examined the claims listed on the foregoing register of claims, consisting of 1
claim, and except for the claims not allowed as shown on the register, such claims are hereby allowed in the
total amount of \$ 580,214.47

Dated this 21st day of May year of 2023.

Kyla Cox Deckard, President Elizabeth Karon, Vice President James Roach, Secretary

I hereby certify that each of the above listed voucher(s) or bill(s) is (are) true and correct and I have audited same in accordance with IC 5-11-10-1.6.

Fiscal Officer _____



Board of Public Works Staff Report

Project/Event: Resolution 2024-030 Public Need to Purchase Right of Way for the High Street Intersection Modernizations and Multiuse Path Project

Petitioner/Representative: Engineering Department

Staff Representative: Neil Kopper, Senior Project Engineer

Date: 05/16/2024

Report: This project includes constructing a multiuse path on the east side of High Street from Arden Drive to Hunter Ave and modernizing the two existing traffic signals within the project limits. This project will require the purchase of additional right of way from up to 38 parcels. If approved by the Board, this resolution will confirm that the Project serves a public purpose and will authorize the right of way acquisition.

<u>Project Approvals Timeline</u>		
<u>Approval Type</u>	<u>Status</u>	<u>Date</u>
Funding Approval (INDOT-LPA Contract)	Approved	--
Design Services Contract	Separate Item	5/16/2024*
ROW Services Contract	Separate Item	5/16/2024
Public Need Resolution	Current Item	5/16/2024
Construction Inspection Contract	Future	2025
Construction Contract	N/A**	2025

* Original PE Contract approved 8/30/2022.

**Construction contracts for federally funded projects are approved and managed by INDOT.

RESOLUTION 2024-030
BOARD OF PUBLIC WORKS
CITY OF BLOOMINGTON, INDIANA
HIGH STREET INTERSECTION MODERNIZATIONS AND MULTIUSE PATH PROJECT
RIGHT OF WAY PURCHASE

WHEREAS, the City of Bloomington through its Board of Public Works (“City”) intends to do construction improvements, including: pavement replacement, multiuse path construction, traffic signal replacement, storm sewer and drainage improvements, and curb ramp replacements on South High Street between East Hunter Avenue and East Arden Drive (the “Project”) in Bloomington, Indiana; and

WHEREAS, the City has determined that there is a need for the Project, and that it will serve a public purpose and be of public benefit; and

WHEREAS, it is necessary to acquire land and/or easements for construction of the Project from the property owners listed in Attachment A, incorporated herein by reference;

NOW, THEREFORE, BE IT RESOLVED THAT:

1. The Project serves a public purpose and will benefit the citizens of Bloomington and Monroe County, Indiana.
2. The acquisition of the land and easements from the property owners listed on Attachment A is hereby authorized. In the event the City is unable to reach agreement with a property owner regarding the purchase of the land or easement within thirty (30) days after the issuance of a formal offer to purchase, as provided in Indiana Code 32-24-1 *et seq.*, the City is hereby authorized to commence eminent domain proceedings.

Approved this _____ day of _____, 2024.

CITY OF BLOOMINGTON, INDIANA
BOARD OF PUBLIC WORKS

Kyla Cox Deckard

Elizabeth Karon

James Roach

ATTACHMENT A

Parcel Number	Property Owner	Address
1	Reformed Presbyterian Church, Trustees Of	2199 E Moores Pike, Bloomington, IN 47401
2	Clay H. Carter, III & Julie A. Carter	1417 S High St., Bloomington, IN 47401-6113
3	Patricia E. Anderson	1415 S High St., Bloomington, IN 47401-6113
4	Roxanne & Bryan Smith	1329 S High St., Bloomington, IN 47401-6111
5	Robert Price & Mary Runells	1321 S High St., Bloomington, IN 47401-6111
6	Daniel Mitchell	1315 S High St., Bloomington, IN 47401-6111
7	Glen, James C & Constance Cook	1300 S Brooks Dr., Bloomington, IN 47401-6116
8	Tilman Piedmont	1309 S High St., Bloomington, IN 47401-6111
9	Matthew S. & Eunice C. Donovan	1303 S High St., Bloomington, IN 47401-6111
10	R&R Martin Realty LLC	2101 E Covenanter Dr., Bloomington, IN 47401-6130
11	Privet Drive LLC.	1213 S High St., Bloomington, IN 47401-6109
11A		1211 S High St., Bloomington, IN 47401-6109
11B		
12	Eric M. Garabrant & Alissia A. Lauer	1105 S High St., Bloomington, IN 47401-6107
13	James P. Cripe & Laila S. Salibi-Cripe	1103 S High St., Bloomington, IN 47401-6107
14	Matthew Aaron Hassfurder	1113 S High St., Bloomington, IN 47401
15	Brian J. McGough	1011 S High St., Bloomington, IN 47401-6287
16	Todd L. & Lisa Thomassen, Janet Louise	1009 S High St., Bloomington, IN 47401-6287
17	Todd L. & Lisa Thomassen	939 S High St., Bloomington, IN 47401-6105
18	Gary M. & Judith Ann Crow	2101 E Woodstock Pl., Bloomington, IN 47401-6182
19	Joel A. Ybe & Ruth A. Gassman	911 S High St., Bloomington, IN 47401-6103
20	Darrel L. & Jane F. Smith Keystone Trust	2100 E Maxwell Ln., Bloomington, IN 47401-6119
21	Sarah Dorwin 2007 Declaration Of Trust	900 S High St., Bloomington, IN 47401-6104
22	Frederick R. Prall	831 S High St., Bloomington, IN 47401-6160
23	Caroline Verdier	821 S High St., Bloomington, IN 47401-6160
24	Rebekah Clare Sheldon	817 S High St., Bloomington, IN 47401-6160
25	Jeffrey M. & Deborah L. Bundy	803 S High St., Bloomington, IN 47401-6160
26	801 South High LLC.	801 S High St., Bloomington, IN 47401-6160
27	Leo B. & Catherine A. Pilachowski	2028 E 1St. St., Bloomington, IN 47401
28	Jeremy D. & Julie A. Warren	717 S High St., Bloomington, IN 47401-5331
29	Feisal Amin & Juliet R. Istrabadi	711 S High St., Bloomington, IN 47401
30	Anjali Kumar	711 S High St., Bloomington, IN 47401
31	Cheng Family Properties, LLC	703 S High St., Bloomington, IN 47401-5331
32	Hussain M. & Parwin Farzad	701 S High St., Bloomington, IN 47401-5331
33	Joseph Christine LLC.	2106 E 2nd St., Bloomington, IN 47401
34	The Evangelical Community Church Of Bloomington	503 S High St., Bloomington, IN 47401-5327
35	Carol E. Mackay Revocable Living Trust	506 S High St., Bloomington, IN 47401-5328
36	Richard A. McClung	2105 E Arden Dr., Bloomington, IN 47401-6834
37	Sycamore Village HOA	E Cape Cod Dr., Bloomington, IN 47401
38	Sara E & James Nicholas Topoligus	2104 E Woodstock Pl., Bloomington, IN 47401-6159



Board of Public Works Staff Report

Project/Event: Approve Amendment 1 to the LPA-Consulting Contract with Butler, Fairman & Seufert, Inc. for Preliminary Engineering Services for the High Street Intersection Modernizations and Multiuse Path Project

Petitioner/Representative: Engineering Department

Staff Representative: Neil Kopper, Senior Project Engineer

Date: 5/21/2024

Report: This project will construct a multiuse path on the east side of High Street from Arden Drive to Hunter Ave and modernize the two existing traffic signals within the project limits. The project is programmed in the MPO TIP for design and construction (\$3,892,064 in federal funds). The City has an existing preliminary engineering contract with BF&S with a not-to-exceed amount of \$862,750.

This amendment will remove some design and right-of-way services that are no longer necessary and will add services for right-of-way appraising and management services. The not-to-exceed contract amount will increase by \$236,640 to a new total of \$1,099,390. Construction of this project is anticipated in 2026.

<u>Project Approvals Timeline</u>		
<u>Approval Type</u>	<u>Status</u>	<u>Date</u>
Funding Approval (INDOT-LPA Contract)	Approved	--
Design Services Contract	Current Item	5/16/2024*
ROW Services Contract	Separate Item	5/16/2024
Public Need Resolution	Separate Item	5/16/2024
Construction Inspection Contract	Future	2025
Construction Contract	N/A**	2025

* Original PE Contract approved 8/30/2022.

**Construction contracts for federally funded projects are approved and managed by INDOT.

City of Bloomington Contract and Purchase Justification Form

Vendor: **Butler, Fairman & Seufert**

Contract Amount: **\$1,099,390**

This form should be completed and attached to the contract documents and forwarded to the Legal Department Attorney assigned to your Department. Contracts will not be approved by the Controller if a completed form is not included with the contract documents.

PURCHASE INFORMATION

1. Check the box beside the procurement method used to initiate this procurement: (Attach a quote or bid tabulation if applicable)

<input type="checkbox"/> Request for Quote (RFQ)	<input checked="" type="checkbox"/> Request for Proposal (RFP)	<input type="checkbox"/> Sole Source	<input type="checkbox"/> Not Applicable (NA)
<input type="checkbox"/> Invitation to Bid (ITB)	<input type="checkbox"/> Request for Qualifications (RFQu)	<input type="checkbox"/> Emergency Purchase	

2. List the results of procurement process. Give further explanation where requested. Yes No

# of Submittals: 6	Yes	No		
Met city requirements?	<input checked="" type="checkbox"/>	<input type="checkbox"/>	Was the lowest cost selected? (If no, please state below why it was not.)	<input type="checkbox"/> <input checked="" type="checkbox"/>
Met item or need requirements?	<input checked="" type="checkbox"/>	<input type="checkbox"/>	Per INDOT requirements, selection was based on qualifications per the highest scoring submittal	
Was an evaluation team used?	<input checked="" type="checkbox"/>	<input type="checkbox"/>		
Was scoring grid used?	<input checked="" type="checkbox"/>	<input type="checkbox"/>		
Were vendor presentations requested?	<input type="checkbox"/>	<input checked="" type="checkbox"/>		

3. State why this vendor was selected to receive the award and contract:

Highest scoring submittal, indicating most qualified consultant, was selected per INDOT requirements for using federal funding.

Neil Kopper

Senior Project Engineer

Engineering

Print/Type Name

Print/Type Title

Department

SUPPLEMENTAL AGREEMENT NO. 1

THIS SUPPLEMENTAL AGREEMENT, made and entered into this _____ day of _____, 2024, by and between the CITY OF BLOOMINGTON, INDIANA hereinafter referred to as the "**LOCAL PUBLIC AGENCY**", and BUTLER, FAIRMAN and SEUFERT, INC., hereinafter referred to as the "**CONSULTANT**."

WITNESSETH

WHEREAS, on September 6, 2022, the **LOCAL PUBLIC AGENCY** entered into an Agreement with the **CONSULTANT** for services in connection with the High Street Multiuse Path and Intersection Modernizations and

WHEREAS, said agreement did not include Right-of-Way Appraising and Management Services Fees and

WHEREAS, design has progressed to the stage at which the landowner impacts and parcel count are more apparent, providing the basis for supplementing said agreement and

WHEREAS, the final parcel count is less than included in said agreement, allowing a revision in unit fees for T&E Reports, Legal Descriptions and Land Plats, and Appraisal Problem Analyses, and

WHEREAS, the project limits and other elements of the project have been revised as follows:

- 1) The original agreement project limits extend from Arden Drive to 3rd Street, including the signalized intersections of Moores Pike, 2nd Street, and 3rd Street; the revised project limits extend from Arden Drive to north of Hunter Avenue; approximately 680' south of 3rd Street, and excluding the 3rd Street signalized intersection.
- 2) A new stormwater outfall is added to the project scope, extending 240' east of High Street.
- 3) Incidental curb ramps and drainage improvements along the west side of high Street are added to the project scope.
- 4) A raised median approaching Hunter Avenue is added to the project scope.
- 5) Additional meetings with individual property owners have been added to the scope of work.

WHEREAS, the reduction project limits results in reduced topographical survey, trail design, and signal design efforts, and

WHEREAS, the addition of incidental project improvements and property owner coordination result in additional design efforts, and

WHEREAS, the changes in design scope of work result in a net reduction in design efforts, and accordingly a net reduction in Trail Design fee and Signal Design fee, and

NOW, THEREFORE, the parties agree that the September 6, 2022, Agreement be modified by this Supplemental Agreement; therefore, the scope shall be supplemented, adding the services set out in Appendix "A - Supplemental 1", adding milestones to the schedule as set out in Appendix "C - Supplemental 1", and adjusting the compensation as set out in Appendix "D - Supplemental 1" increasing the total agreed upon amount by \$ 236,640.00 from \$ 862,750.00 to an amount not-to-exceed \$ 1,099,390.00.

IN TESTIMONY WHEREOF, the parties hereto have executed this Supplemental Agreement.

**CONSULTANT
BUTLER, FAIRMAN and SEUFERT,
INC.**

**LOCAL PUBLIC AGENCY
CITY OF BLOOMINGTON, INDIANA
BOARD OF PUBLIC WORKS**

Signature
Michael D. Eichenauer, Executive V.P.

Signature
Kyla Cox Deckard, President

Signature
Elizabeth Karon, Vice President

Signature
James Roach, Secretary

Signature
Kerry Thomson, Mayor

APPENDIX "A – Supplemental 1"

SERVICES TO BE FURNISHED BY CONSULTANT:

The **CONSULTANT** shall be responsible for performing the following activities:

- A. The **CONSULTANT** shall provide RIGHT-OF-WAY SERVICES for the parcels tabulated in Exhibit "A" of Appendix "D – Supplemental 1" including the following:
1. RIGHT-OF-WAY MANAGEMENT AND SUPERVISION - The **CONSULTANT** shall be responsible for administering, scheduling and coordinating all activities necessary to certify that the right-of-way has been acquired and that the project is clear for construction letting. This responsibility will include:
 - a. Meetings, conference calls, and communications with property owners, attorneys, engineers, appraisers, buyers, and **LOCAL PUBLIC AGENCY**.
 - b. Recommend revisions to construction plans and/or right-of-way plans.
 - c. The Right-of-Way Services include all reasonable services as required to secure all parcels based on the approved engineering design, to recommend to the **LOCAL PUBLIC AGENCY** that condemnation proceedings be filed.
 - d. The **CONSULTANT** will make arrangements for recording all necessary documents after a copy of payment is provided by the **LOCAL PUBLIC AGENCY**.
 - e. Direct Cost expenses are those costs for partial mortgage release fees, recording fees if any, any appraisal cost-to-cure estimate fees, and other charges to clear title of the property acquired.
 - f. Fee Scope Changes for Appraisal or Buying Fees: The use of additional funds set aside to allow the payment of an increase in an appraisal scope change resulting from the inspection with the owner. The funds also allow for additional increase in buyer fee resulting in the change in title to clear encumbrances.
 - g. Additional Services: The **CONSULTANT** will provide additional services to the **LOCAL PUBLIC AGENCY** and/or the attorney, as requested, to provide support services in condemnation proceedings or administrative settlements and additional parcel(s). The **CONSULTANT** will also provide additional services as directed to the contract vendors or outside vendors as necessary and the cost of the additional services by the vendor(s) will be a direct pass through. The **CONSULTANT** will obtain approval by Email, letter or supplemental, from the **LOCAL PUBLIC AGENCY's** representative prior to any additional work is provided.
 2. APPRAISING AND REVIEW APPRAISING
 - a. The Appraiser shall be a licensed real estate appraiser in the State of Indiana.
 - b. Should the quality and/or progress of the appraisals be deemed unsatisfactory, the **LOCAL PUBLIC AGENCY** may terminate the services of the Appraiser by giving five (5) days written notice. The earned value of the work performed shall be based upon an estimate of the portion of the services as have been rendered by the Appraiser to the date of termination. All work, completed or partially completed, shall become the property of the **LOCAL PUBLIC AGENCY**.
 - c. The Appraiser shall follow accepted principles and techniques in evaluation of real property in accordance with State Laws. Any appraisal that does not meet such requirements shall be further documented or re-appraised as the case may be without additional compensation to the Appraiser.
 - d. The Appraiser agrees to furnish one original and a PDF file of the appraisal report.
 - e. All information contained in the appraisal report and all parts thereof are to be treated as a privileged communication. The Appraiser shall take all necessary steps to ensure that neither he/she nor any member of his/her staff or organization divulges

any information concerning the report except to a duly authorized representative of the **LOCAL PUBLIC AGENCY**, until authorized in writing by the **LOCAL PUBLIC AGENCY** to reveal the communication to another designated party.

APPENDIX "C – Supplemental 1"

SCHEDULE:

No work under this Contract shall be performed by the **CONSULTANT** until the **CONSULTANT** receives a written notice to proceed from the **LOCAL PUBLIC AGENCY**.

All work by the **CONSULTANT** under this Contract shall be completed and delivered to the **LOCAL PUBLIC AGENCY** for review and approval within the approximate time periods shown in the following submission schedule:

Conceptual Scoping Report	January 3, 2023
Topographic Survey Complete	April 3, 2023
Preliminary Field Check submission and conduct Field Check	November 19, 2023
RW Engineering Complete	July 15, 2024
Appraising Complete	September 15, 2024
Review Appraising Complete	October 15, 2024
Draft Environmental Document submitted to INDOT	March 18, 2024
Final Environmental Document approval from INDOT	September 14, 2024
Stage 3 Plan Submittal to INDOT	February 14, 2025
Final Tracing Plan Submittal to INDOT	June 16, 2025

APPENDIX "D – Supplemental 1"

COMPENSATION:

A. Amount of Payment

1. Design services performed under this Contract are revised as follows:

<u>Service</u>	<u>Original Fee</u>	<u>Revised Fee</u>	<u>Difference</u>
Topographic Survey	\$ 56,700.00	\$64,800.00	\$8,100.00
Path Design	\$405,950.00	\$392,950.00	-\$13,000.00
Traffic Signal Design	\$17,850.00	\$12,500.00	<u>-\$5,350.00</u>
	Total Difference:		<u>-\$10,250.00</u>

2. The **CONSULTANT** will be paid for the Right-of-Way Services performed under this Contract in accordance with the following schedule:

<u>Revised Service</u>	<u>Quantity</u>	<u>Unit Price</u>	<u>Total</u>
T&E Reports	40 parcels ^(A)	\$500.00	\$20,000.00
Legal Desc. and Land Plats	40 parcels ^(A)	\$1,850.00	\$74,000.00
Appraisal Problem Analyses	40 parcels ^(A)	\$300.00	\$12,000.00
	TOTAL from September 6, 2022 agreement		\$132,500.00
	REVISED TOTAL		\$106,000.00

^(A) Reduced from 50 parcels reflected in the September 6, 2022 agreement

<u>Added Service</u>	<u>Quantity</u>	<u>Unit Price</u>	<u>Total</u>
Right-of Way Management	See Table (Exhibit "A")		\$52,355.00
Appraisal	See Table (Exhibit "A")		\$123,015.00
Review Appraising	See Table (Exhibit "A")		\$58,820.00
Fee Scope Changes for Appraisal (Not to Exceed)			<u>\$18,200.00</u>
TOTAL			\$252,390.00

The **CONSULTANT** will be paid Unit Rates for the Right-of-Way Services performed under this Agreement as depicted on the above schedule as tabulated in Exhibit "A".

3. The LOCAL PUBLIC AGENCY agrees to compensate the CONSULTANT for On-Call Additional Services on the basis of actual hours of work performed on the project at the hourly billing rates noted in APPENDIX "D-1" of said agreement. The Hourly Billing Rates include overhead and fixed fee. The CONSULTANT will be paid for the following work under additional services in accordance with the following schedule of Not-to-Exceed (NTE) fees. Potential on-call additional services required:

Revisions to Documents related to Owner and Property Owner(s) Right-of-Way Acquisition as well as prolonged negotiation efforts for parcels not secured after initial offer and response to one counteroffer. \$7,500.00

4. The CONSULTANT will be reimbursed for direct project-related expenses. Subconsultant reimbursable expenses will be invoiced at cost with no mark-up. Estimated reimbursable expenses are:

Right of Way Acquisition and Management Services (NTE) \$7,500.00

APPENDIX "D – Supplemental 1"



EXHIBIT "A"

High Street Trail - Des. No. 2200020

City of Bloomington

Right-of-Way Services Summary

Parcel Number	Property Owner	ROW Mgmt.	Appr. Type	Appraising	Review Appraising
1	Reformed Presbyterian Church, Trustees Of	\$ 1,365.00	SF ANY	\$ 3,140.00	\$ 1,505.00
2	Clay H. Carter, III & Julie A. Carter	\$ 1,365.00	LF ANY	\$ 3,770.00	\$ 1,795.00
3	Patricia E. Anderson	\$ 1,365.00	LF ANY	\$ 3,770.00	\$ 1,795.00
4	Roxanne & Bryan Smith	\$ 1,365.00	LF ANY	\$ 3,770.00	\$ 1,795.00
5	Robert Price & Mary Runells	\$ 1,365.00	LF ANY	\$ 3,770.00	\$ 1,795.00
6	Daniel Mitchell	\$ 1,365.00	LF ANY	\$ 3,770.00	\$ 1,795.00
7	Glen, James C & Constance Cook	\$ 1,365.00	VF	\$ 2,140.00	\$ 1,080.00
8	Tilman Piedmont	\$ 1,365.00	LF ANY	\$ 3,770.00	\$ 1,795.00
9	Matthew S. & Eunice C. Donovan	\$ 1,365.00	SF ANY	\$ 3,140.00	\$ 1,505.00
10	Jennifer E. & Ryan W. Martin	\$ 1,365.00	VF	\$ 2,140.00	\$ 1,080.00
11	Privet Drive LLC.	\$ 1,365.00	SF ANY	\$ 3,140.00	\$ 1,505.00
12	Eric M. Garabrant & Alissia A. Lauer	\$ 1,365.00	LF ANY	\$ 3,770.00	\$ 1,795.00
13	James P. Cripe & Laila S. Salibi-Cripe	\$ 1,365.00	LF ANY	\$ 3,770.00	\$ 1,795.00
14	Matthew Aaron Hassfurder	\$ 1,365.00	LF ANY	\$ 3,770.00	\$ 1,795.00
15	Brian J. McGough	\$ 1,365.00	LF ANY	\$ 3,770.00	\$ 1,795.00
16	Todd L. & Lisa Thomassen, Janet Louise	\$ 1,365.00	SF ANY	\$ 3,140.00	\$ 1,505.00
17	Todd L. & Lisa Thomassen	\$ 1,365.00	VF	\$ 2,140.00	\$ 1,080.00
18	Gary M. & Judith Ann Crow	\$ 1,365.00	VF	\$ 2,140.00	\$ 1,080.00
19	Joel A. Ybe & Ruth A. Gassman	\$ 1,365.00	SF ANY	\$ 3,140.00	\$ 1,505.00
20	Darrel L. & Jane F. Smith Keystone Trust	\$ 1,365.00	SF ANY	\$ 3,140.00	\$ 1,505.00
21	Sarah Dorwin 2007 Declaration Of Trust	\$ 1,365.00	SF ANY	\$ 3,140.00	\$ 1,505.00
22	Frederick R. Prall	\$ 1,365.00	SF ANY	\$ 3,140.00	\$ 1,505.00
23	Caroline Verdier	\$ 1,365.00	SF ANY	\$ 3,140.00	\$ 1,505.00
24	Rebekah Clare Sheldon	\$ 1,365.00	SF ANY	\$ 3,140.00	\$ 1,505.00
25	Jeffrey M. & Deborah L. Bundy	\$ 1,365.00	SF ANY	\$ 3,140.00	\$ 1,505.00
26	801 South High LLC.	\$ 1,365.00	SF ANY	\$ 3,140.00	\$ 1,505.00
27	Leo B. & Catherine A. Pilachowski	\$ 1,365.00	SF ANY	\$ 3,140.00	\$ 1,505.00
28	Jeremy D. & Julie A. Warren	\$ 1,365.00	LF ANY	\$ 3,770.00	\$ 1,795.00
29	Feisal Amin & Juliet R. Istrabadi	\$ 1,365.00	LF ANY	\$ 3,770.00	\$ 1,795.00
30	Anjali Kumar	\$ 1,365.00	LF ANY	\$ 3,770.00	\$ 1,795.00
31	Cheng Family Properties, LLC	\$ 1,365.00	LF ANY	\$ 3,770.00	\$ 1,795.00
32	Hussain M. & Parwin Farzad	\$ 1,365.00	LF ANY	\$ 3,770.00	\$ 1,795.00
33	Joseph Christine LLC.	\$ 1,365.00	LF RES/AG	\$ 5,010.00	\$ 2,375.00
34	The Evangelical Community Church Of Bloomington	\$ 1,365.00	SF COM/IND	\$ 4,900.00	\$ 2,395.00
35	Carol E. Mackay Revocable Living Trust	\$ 1,365.00	VF	\$ 2,140.00	\$ 1,080.00
36	Richard A. McClung	\$ 1,850.00	WV	\$ 755.00	
37	Sycamore Village HOA	\$ 1,365.00	VF	\$ 2,140.00	\$ 1,080.00
38	Sara E & James Nicholas Topoligus	\$ 1,365.00	VF	\$ 2,140.00	\$ 1,080.00
Totals		\$ 52,355.00		\$ 123,015.00	\$ 58,820.00
ROW Management -----				\$ 52,355.00	
Total Appraising-----				\$ 123,015.00	\$ 252,390.00
Total Review Appraising-----				\$ 58,820.00	
Appraisal & Buying Parcel Scope Changes-----				\$ 18,200.00	
Additional Services-----				\$ 7,500.00	Additional Services
Direct Expenses & Fees (Cost-to-Cure, etc.) -----				\$ 7,500.00	Direct Expenses
Total Right-of-Way Services -----				\$ 267,390.00	

APPENDIX "D – Supplemental 1"



High Street Trail - Des. No. 2200020

City of Bloomington

Agreement Summary

Item	Original	Supplement 1	Item Total
Conceptual Scoping Report	\$ 18,000.00	\$ -	\$ 18,000.00
Topographic Survey	\$ 56,700.00	\$ 8,100.00	\$ 64,800.00
Environmental Document (CE)	\$ 19,900.00	\$ -	\$ 19,900.00
Historic Properties Section 106/4(f) (CE)	\$ 31,800.00	\$ -	\$ 31,800.00
IDNR Construction in a Floodway Permit (non-modeling)	\$ 3,400.00	\$ -	\$ 3,400.00
IDNR Floodway Permit Tree Impact Analysis	\$ 1,350.00	\$ -	\$ 1,350.00
IDEM 401/USACE 404 Water Quality Permits	\$ 5,100.00	\$ -	\$ 5,100.00
Path Design	\$ 405,950.00	\$ (13,000.00)	\$ 392,950.00
Traffic Signal Design	\$ 17,850.00	\$ (5,350.00)	\$ 12,500.00
Traffic Counts and Analysis	\$ 13,000.00	\$ -	\$ 13,000.00
IDEM CSGP Erosion and Sediment Control Permit	\$ 5,000.00	\$ -	\$ 5,000.00
Project Management & Administration	\$ 20,200.00	\$ -	\$ 20,200.00
Utility Coordination and Certification	\$ 13,900.00	\$ -	\$ 13,900.00
Utility Coordination Construction Phase	\$ 5,100.00	\$ -	\$ 5,100.00
Total	\$ 617,250.00	\$ (10,250.00)	\$ 607,000.00
Establish R/W and property lines, R/W oversight	\$ 17,500.00	\$ -	\$ 17,500.00
T&E Reports	\$ 25,000.00	\$ (5,000.00)	\$ 20,000.00
Legal Descriptions and Land Plats	\$ 92,500.00	\$ (18,500.00)	\$ 74,000.00
R/W Plans	\$ 17,000.00	\$ -	\$ 17,000.00
Appraisal Problem Analysis	\$ 15,000.00	\$ (3,000.00)	\$ 12,000.00
Right-of-Way Management	\$ -	\$ 52,355.00	\$ 52,355.00
Appraising	\$ -	\$ 123,015.00	\$ 123,015.00
Review Appraising	\$ -	\$ 58,820.00	\$ 58,820.00
Appraisal Scope Changes	\$ -	\$ 18,200.00	\$ 18,200.00
Additional Services for Right-of-Way acquisition	\$ -	\$ 7,500.00	\$ 7,500.00
Direct Expenses & Fees	\$ -	\$ 7,500.00	\$ 7,500.00
Total	\$ 167,000.00	\$ 240,890.00	\$ 407,890.00
Potential on-call additional services required:	\$ 10,000.00	\$ -	\$ 10,000.00
Public Engagement & Information Meetings	\$ 15,000.00	\$ 6,000.00	\$ 21,000.00
NEPA Public Involvement (Hearing or Individual Meetings)	\$ 11,000.00	\$ -	\$ 11,000.00
Utility Relocation Staking	\$ 2,000.00	\$ -	\$ 2,000.00
Follow-up Utility Survey	\$ 2,500.00	\$ -	\$ 2,500.00
Geotechnical Investigation	\$ 38,000.00	\$ -	\$ 38,000.00
Total	\$ 78,500.00	\$ 6,000.00	\$ 84,500.00
Grand Total	\$ 862,750.00	\$ 236,640.00	\$ 1,099,390.00



Board of Public Works Staff Report

Project/Event: Approve LPA-Consulting Contract with Butler, Fairman & Seufert, Inc. for Right of Way Acquisition Services for the High Street Intersection Modernizations and Multiuse Path Project

Petitioner/Representative: Engineering Department

Staff Representative: Neil Kopper, Senior Project Engineer

Date: 5/21/2024

Report: This project will construct a multiuse path on the east side of High Street from Arden Drive to Hunter Ave and modernize the two existing traffic signals within the project limits. The project is programmed in the MPO TIP for design and construction (\$3,892,064 in federal funds).

The City has an existing preliminary engineering contract with BF&S. A separate contract is necessary for right of way acquisition services because the existing preliminary engineering contract has limitations related to federal funding reimbursements. This new contract includes services for buying and related services. The not-to-exceed contract amount for this new contract is set at \$122,100. Construction of this project is anticipated in 2026.

<u>Project Approvals Timeline</u>		
<u>Approval Type</u>	<u>Status</u>	<u>Date</u>
Funding Approval (INDOT-LPA Contract)	Approved	--
Design Services Contract	Separate Item	5/16/2024*
ROW Services Contract	Current Item	5/16/2024
Public Need Resolution	Separate Item	5/16/2024
Construction Inspection Contract	Future	2025
Construction Contract	N/A**	2025

* Original PE Contract approved 8/30/2022.

**Construction contracts for federally funded projects are approved and managed by INDOT.

City of Bloomington Contract and Purchase Justification Form

Vendor: Butler, Fairman & Seufert

Contract Amount: \$122,100

This form should be completed and attached to the contract documents and forwarded to the Legal Department Attorney assigned to your Department. Contracts will not be approved by the Controller if a completed form is not included with the contract documents.

PURCHASE INFORMATION

1. Check the box beside the procurement method used to initiate this procurement: (Attach a quote or bid tabulation if applicable)

<input type="checkbox"/> Request for Quote (RFQ)	<input checked="" type="checkbox"/> Request for Proposal (RFP)	<input type="checkbox"/> Sole Source	<input type="checkbox"/> Not Applicable (NA)
<input type="checkbox"/> Invitation to Bid (ITB)	<input type="checkbox"/> Request for Qualifications (RFQu)	<input type="checkbox"/> Emergency Purchase	

2. List the results of procurement process. Give further explanation where requested. Yes No

# of Submittals: 6	Yes	No		Yes	No
Met city requirements?	<input checked="" type="checkbox"/>	<input type="checkbox"/>	Was the lowest cost selected? (If no, please state below why it was not.)	<input type="checkbox"/>	<input checked="" type="checkbox"/>
Met item or need requirements?	<input checked="" type="checkbox"/>	<input type="checkbox"/>	Per INDOT requirements, selection was based on qualifications per the highest scoring submittal		
Was an evaluation team used?	<input checked="" type="checkbox"/>	<input type="checkbox"/>			
Was scoring grid used?	<input checked="" type="checkbox"/>	<input type="checkbox"/>			
Were vendor presentations requested?	<input type="checkbox"/>	<input checked="" type="checkbox"/>			

3. State why this vendor was selected to receive the award and contract:
 Highest scoring submittal, indicating most qualified consultant, was selected per INDOT requirements for using federal funding.

Neil Kopper

 Print/Type Name

Senior Project Engineer

 Print/Type Title

Engineering

 Department

LPA - CONSULTING CONTRACT

This Contract (“this Contract”) is made and entered into effective as of _____, 20____ (“Effective Date”) by and between the CITY OF BLOOMINGTON, INDIANA, acting by and through its proper officials (“LOCAL PUBLIC AGENCY” or “LPA”), and BUTLER, FAIRMAN AND SEUFERT, INC. (“the CONSULTANT”), a corporation/limited liability company organized under the laws of the State of Indiana.

Des. No.: 2200020

Project Description: High Street Multiuse Path and Intersection Modernizations: extension of the existing shared-use path along High Street, from Arden Drive to 3rd Street.

RECITALS

WHEREAS, the LPA has entered into an agreement to utilize federal monies with the Indiana Department of Transportation (“INDOT”) for a transportation or transportation enhancement project (“the Project”), which Project Coordination Contract is herein attached as Attachment 1 and incorporated as reference; and

WHEREAS, the LPA wishes to hire the CONSULTANT to provide services toward the Project completion more fully described in Appendix “A” attached hereto (“Services”);

WHEREAS, the CONSULTANT has extensive experience, knowledge and expertise relating to these Services; and

WHEREAS, the CONSULTANT has expressed a willingness to furnish the Services in connection therewith.

NOW, THEREFORE, in consideration of the following mutual covenants, the parties hereto mutually covenant and agree as follows:

The “Recitals” above are hereby made an integral part and specifically incorporated into this Contract.

SECTION I SERVICES BY CONSULTANT. The CONSULTANT will provide the Services and deliverables described in Appendix “A” which is herein attached to and made an integral part of this Contract.

SECTION II INFORMATION AND SERVICES TO BE FURNISHED BY THE LPA. The information and services to be furnished by the LPA are set out in Appendix “B” which is herein attached to and made an integral part of this Contract.

SECTION III TERM. The term of this Contract shall be from the date of the last signature affixed to this Contract to the completion of the construction contract which is estimated to be 1000 days. A schedule for completion of the Services and deliverables is set forth in Appendix “C” which is herein attached to and made an integral part of this Contract.

SECTION IV COMPENSATION. The LPA shall pay the CONSULTANT for the Services performed under this Contract as set forth in Appendix “D” which is herein attached to and made an integral part of this Contract. The maximum amount payable under this Contract shall not exceed \$ 122,100.00.

SECTION V NOTICE TO PROCEED AND SCHEDULE. The CONSULTANT shall begin the work to be performed under this Contract only upon receipt of the written notice to proceed from the LPA, and shall deliver the work to the LPA in accordance with the schedule contained in Appendix “C” which is herein attached to and made an integral part of this Contract.

SECTION VI GENERAL PROVISIONS

1. **Access to Records.** The CONSULTANT and any SUB-CONSULTANTS shall maintain all books, documents, papers, correspondence, accounting records and other evidence pertaining to the cost incurred under this Contract, and shall make such materials available at their respective offices at all reasonable times during the period of this Contract and for five (5) years from the date of final payment under the terms of this Contract, for inspection or audit by the LPA, INDOT and/or the Federal Highway Administration (“FHWA”) or its authorized representative, and copies thereof shall be furnished free of charge, if requested by the LPA, INDOT, and/or FHWA. The CONSULTANT agrees that, upon request by any agency participating in federally-assisted programs with whom the CONSULTANT has contracted or seeks to contract, the CONSULTANT may release or make available to the agency any working papers from an audit performed by the LPA, INDOT and/or FHWA of the CONSULTANT and its SUB-CONSULTANTS in connection with this Contract, including any books, documents, papers, accounting records and other documentation which support or form the basis for the audit conclusions and judgments.

2. **Assignment; Successors.**
 - A. The CONSULTANT binds its successors and assignees to all the terms and conditions of this Contract. The CONSULTANT shall not assign or subcontract the whole or any part of this Contract without the LPA’s prior written consent, except that the CONSULTANT may assign its right to receive payments to such third parties as the CONSULTANT may desire without the prior written consent of the LPA, provided that the CONSULTANT gives written notice (including evidence of such assignment) to the LPA thirty (30) days in advance of any payment so assigned. The assignment shall cover all unpaid amounts under this Contract and shall not be made to more than one party.

 - B. Any substitution of SUB-CONSULTANTS must first be approved and receive written authorization from the LPA. Any substitution or termination of a Disadvantaged Business Enterprise (“DBE”) SUB-CONSULTANT must first be approved and receive written authorization from the LPA and INDOT’s Economic Opportunity Division Director.

3. **Audit.** The CONSULTANT acknowledges that it may be required to submit to an audit of funds paid through this Contract. Any such audit shall be conducted in accordance with 48 CFR part 31 and audit guidelines specified by the State and/or in accordance with audit requirements specified elsewhere in this Contract.

4. **Authority to Bind Consultant.** The CONSULTANT warrants that it has the necessary authority to enter into this Contract. The signatory for the CONSULTANT represents that he/she has been duly authorized to execute this Contract on behalf of the CONSULTANT and has obtained all necessary or applicable approval to make this Contract fully binding upon the CONSULTANT when his/her signature is affixed hereto.

5. **Certification for Federal-Aid Contracts Lobbying Activities.**
 - A. The CONSULTANT certifies, by signing and submitting this Contract, to the best of its knowledge and belief after diligent inquiry, and other than as disclosed in writing to the LPA prior to or contemporaneously with the execution and delivery of this Contract by the CONSULTANT, the CONSULTANT has complied with Section 1352, Title 31, U.S. Code, and specifically, that:
 - i. No federal appropriated funds have been paid, or will be paid, by or on behalf of the CONSULTANT to any person for influencing or attempting to influence an officer or

employee of any federal agency, a Member of Congress, an officer or employee of Congress, or an employee of a Member of Congress in connection with the awarding of any federal contracts, the making of any federal grant, the making of any federal loan, the entering into of any cooperative agreement, and the extension, continuation, renewal, amendment, or modification of any federal contract, grant, loan, or cooperative agreement.

- ii. If any funds other than federal appropriated funds have been paid or will be paid to any person for influencing or attempting to influence an officer or employee of any Federal agency, a Member of Congress, an officer or employee of Congress, or an employee of a Member of Congress in connection with this federal Contract, grant, loan, or cooperative agreement, the undersigned shall complete and submit Standard Form-LLL, "Disclosure Form to Report Lobbying," in accordance with its instructions.

- B. The CONSULTANT also agrees by signing this Contract that it shall require that the language of this certification be included in all lower tier subcontracts, which exceed \$100,000, and that all such sub-recipients shall certify and disclose accordingly. Any person who fails to sign or file this required certification shall be subject to a civil penalty of not less than \$10,000 and not more than \$100,000 for each failure.

- 6. **Changes in Work.** The CONSULTANT shall not commence any additional work or change the scope of the work until authorized in writing by the LPA. The CONSULTANT shall make no claim for additional compensation or time in the absence of a prior written approval and amendment executed by all signatories hereto. This Contract may be amended, supplemented or modified only by a written document executed in the same manner as this Contract. The CONSULTANT acknowledges that no claim for additional compensation or time may be made by implication, oral agreements, actions, inaction, or course of conduct.

- 7. **Compliance with Laws.**

- A. The CONSULTANT shall comply with all applicable federal, state and local laws, rules, regulations and ordinances, and all provisions required thereby to be included herein are hereby incorporated by reference. If the CONSULTANT violates such rules, laws, regulations and ordinances, the CONSULTANT shall assume full responsibility for such violations and shall bear any and all costs attributable to the original performance of any correction of such acts. The enactment of any state or federal statute, or the promulgation of regulations thereunder, after execution of this Contract, shall be reviewed by the LPA and the CONSULTANT to determine whether formal modifications are required to the provisions of this Contract.

- B. The CONSULTANT represents to the LPA that, to the best of the CONSULTANT'S knowledge and belief after diligent inquiry and other than as disclosed in writing to the LPA prior to or contemporaneously with the execution and delivery of this Contract by the CONSULTANT:

- i. *State of Indiana Actions.* The CONSULTANT has no current or outstanding criminal, civil, or enforcement actions initiated by the State of Indiana pending, and agrees that it will immediately notify the LPA of any such actions. During the term of such actions, CONSULTANT agrees that the LPA may delay, withhold, or deny work under any supplement or amendment, change order or other contractual device issued pursuant to this Contract.

- ii. *Professional Licensing Standards.* The CONSULTANT, its employees and SUBCONSULTANTS have complied with and shall continue to comply with all

applicable licensing standards, certification standards, accrediting standards and any other laws, rules or regulations governing services to be provided by the CONSULTANT pursuant to this Contract.

- iii. *Work Specific Standards.* The CONSULTANT and its SUB-CONSULTANTS, if any, have obtained, will obtain and/or will maintain all required permits, licenses, registrations and approvals, as well as comply with all health, safety, and environmental statutes, rules, or regulations in the performance of work activities for the LPA.
 - iv. *Secretary of State Registration.* If the CONSULTANT is an entity described in IC Title 23, it is properly registered and owes no outstanding reports with the Indiana Secretary of State.
 - v. *Debarment and Suspension of CONSULTANT.* Neither the CONSULTANT nor its principals are presently debarred, suspended, proposed for debarment, declared ineligible, or voluntarily excluded from entering into this Contract by any federal agency or by any department, agency or political subdivision of the State and will immediately notify the LPA of any such actions. The term “principal” for purposes of this Contract means an officer, director, owner, partner, key employee, or other person with primary management or supervisory responsibilities, or a person who has a critical influence on or substantive control over the operations of the CONSULTANT or who has managerial or supervisory responsibilities for the Services.
 - vi. *Debarment and Suspension of any SUB-CONSULTANTS.* The CONSULTANT’s SUB-CONSULTANTS are not presently debarred, suspended, proposed for debarment, declared ineligible, or voluntarily excluded from entering into this Contract by any federal agency or by any department, agency or political subdivision of the State. The CONSULTANT shall be solely responsible for any recoupment, penalties or costs that might arise from the use of a suspended or debarred SUBCONSULTANT. The CONSULTANT shall immediately notify the LPA and INDOT if any SUB-CONSULTANT becomes debarred or suspended, and shall, at the LPA’s request, take all steps required by the LPA to terminate its contractual relationship with the SUB-CONSULTANT for work to be performed under this Contract.
- C. *Violations.* In addition to any other remedies at law or in equity, upon CONSULTANT’S violation of any of Section 7(A) through 7(B), the LPA may, at its sole discretion, do any one or more of the following:
- i. terminate this Contract; or
 - ii. delay, withhold, or deny work under any supplement or amendment, change order or other contractual device issued pursuant to this Contract.
- D. *Disputes.* If a dispute exists as to the CONSULTANT’s liability or guilt in any action initiated by the LPA, and the LPA decides to delay, withhold, or deny work to the CONSULTANT, the CONSULTANT may request that it be allowed to continue, or receive work, without delay. The CONSULTANT must submit, in writing, a request for review to the LPA. A determination by the LPA under this Section 7.D shall be final and binding on the parties and not subject to administrative review. Any payments the LPA may delay, withhold, deny, or apply under this section shall not be subject to penalty or interest under IC 5-17-5.

8. **Condition of Payment.** The CONSULTANT must perform all Services under this Contract to the LPA’s reasonable satisfaction, as determined at the discretion of the LPA and in accordance with all

applicable federal, state, local laws, ordinances, rules, and regulations. The LPA will not pay for work not performed to the LPA's reasonable satisfaction, inconsistent with this Contract or performed in violation of federal, state, or local law (collectively, "deficiencies") until all deficiencies are remedied in a timely manner.

9. Confidentiality of LPA Information.

- A. The CONSULTANT understands and agrees that data, materials, and information disclosed to the CONSULTANT may contain confidential and protected information. Therefore, the CONSULTANT covenants that data, material, and information gathered, based upon or disclosed to the CONSULTANT for the purpose of this Contract, will not be disclosed to others or discussed with third parties without the LPA's prior written consent.
- B. The parties acknowledge that the Services to be performed by the CONSULTANT for the LPA under this Contract may require or allow access to data, materials, and information containing Social Security numbers and maintained by the LPA in its computer system or other records. In addition to the covenant made above in this section and pursuant to 10 IAC 5-3-1(4), the CONSULTANT and the LPA agree to comply with the provisions of IC 4-1-10 and IC 4-1-11. If any Social Security number(s) is/are disclosed by the CONSULTANT, the CONSULTANT agrees to pay the cost of the notice of disclosure of a breach of the security of the system in addition to any other claims and expenses for which it is liable under the terms of this Contract.

10. Delays and Extensions. The CONSULTANT agrees that no charges or claim for damages shall be made by it for any minor delays from any cause whatsoever during the progress of any portion of the Services specified in this Contract. Such delays, if any, shall be compensated for by an extension of time for such period as may be determined by the LPA subject to the CONSULTANT's approval, it being understood, however, that permitting the CONSULTANT to proceed to complete any services, or any part of them after the date to which the time of completion may have been extended, shall in no way operate as a waiver on the part of the LPA of any of its rights herein. In the event of substantial delays or extensions, or change of any kind, not caused by the CONSULTANT, which causes a material change in scope, character or complexity of work the CONSULTANT is to perform under this Contract, the LPA at its sole discretion shall determine any adjustments in compensation and in the schedule for completion of the Services. CONSULTANT must notify the LPA in writing of a material change in the work immediately after the CONSULTANT first recognizes the material change.

11. DBE Requirements.

- A. Notice is hereby given to the CONSULTANT and any SUB-CONSULTANT, and both agree, that failure to carry out the requirements set forth in 49 CFR Sec. 26.13(b) shall constitute a breach of this Contract and, after notification and failure to promptly cure such breach, may result in termination of this Contract or such remedy as INDOT deems appropriate. The referenced section requires the following assurance to be included in all subsequent contracts between the CONSULTANT and any SUB-CONSULTANT:

The CONSULTANT, sub recipient or SUB-CONSULTANT shall not discriminate on the basis of race, color, national origin, or sex in the performance of this Contract. The CONSULTANT shall carry out applicable requirements of 49 CFR Part 26 in the award and administration of DOT-assisted contracts. Failure by the CONSULTANT to carry out these requirements is a material breach of this Contract, which may result in the termination of this Contract or such other remedy, as INDOT, as the recipient, deems appropriate.

- B. The CONSULTANT shall make good faith efforts to achieve the DBE percentage goal that may be included as part of this Contract with the approved DBE SUB-CONSULTANTS identified on its Affirmative Action Certification submitted with its Letter of Interest, or with approved amendments. Any changes to a DBE firm listed in the Affirmative Action Certification must be requested in writing and receive prior approval by the LPA and INDOT's Economic Opportunity Division Director. After this Contract is completed and if a DBE SUB-CONSULTANT has performed services thereon, the CONSULTANT must complete, and return, a Disadvantaged Business Enterprise Utilization Affidavit ("DBE-3 Form") to INDOT's Economic Opportunity Division Director. The DBE-3 Form requires certification by the CONSULTANT AND DBE SUB-CONSULTANT that the committed contract amounts have been paid and received.

12. Non-Discrimination.

- A. Pursuant to I.C. 22-9-1-10, the Civil Rights Act of 1964, and the Americans with Disabilities Act, the CONSULTANT shall not discriminate against any employee or applicant for employment, to be employed in the performance of work under this Contract, with respect to hire, tenure, terms, conditions or privileges of employment or any matter directly or indirectly related to employment, because of race, color, religion, sex, disability, national origin, ancestry or status as a veteran. Breach of this covenant may be regarded as a material breach of this Contract. Acceptance of this Contract also signifies compliance with applicable federal laws, regulations, and executive orders prohibiting discrimination in the provision of services based on race, color, national origin, age, sex, disability or status as a veteran.
- B. The CONSULTANT understands that the LPA is a recipient of federal funds. Pursuant to that understanding, the CONSULTANT agrees that if the CONSULTANT employs fifty (50) or more employees and does at least \$50,000.00 worth of business with the State and is not exempt, the CONSULTANT will comply with the affirmative action reporting requirements of 41 CFR 60-1.7. The CONSULTANT shall comply with Section 202 of executive order 11246, as amended, 41 CFR 60-250, and 41 CFR 60-741, as amended, which are incorporated herein by specific reference. Breach of this covenant may be regarded as a material breach of Contract.

It is the policy of INDOT to assure full compliance with Title VI of the Civil Rights Act of 1964, the Americans with Disabilities Act and Section 504 of the Vocational Rehabilitation Act and related statutes and regulations in all programs and activities. Title VI and related statutes require that no person in the United States shall on the grounds of race, color or national origin be excluded from participation in, be denied the benefits of, or be subjected to discrimination under any program or activity receiving Federal financial assistance. (INDOT's Title VI enforcement shall include the following additional grounds: sex, ancestry, age, income status, religion and disability.)

- C. The CONSULTANT shall not discriminate in its selection and retention of contractors, including without limitation, those services retained for, or incidental to, construction, planning, research, engineering, property management, and fee contracts and other commitments with persons for services and expenses incidental to the acquisitions of right-of-way.
- D. The CONSULTANT shall not modify the Project in such a manner as to require, on the basis of race, color or national origin, the relocation of any persons. (INDOT's Title VI enforcement will include the following additional grounds; sex, ancestry, age, income status, religion and disability).
- E. The CONSULTANT shall not modify the Project in such a manner as to deny reasonable access to and use thereof to any persons on the basis of race, color or national origin. (INDOT's Title

VI enforcement will include the following additional grounds; sex, ancestry, age, income status, religion and disability.)

- F. The CONSULTANT shall neither allow discrimination by contractors in their selection and retention of subcontractors, lessors and/or material suppliers, nor allow discrimination by their subcontractors in their selection of subcontractors, lessors or material suppliers, who participate in construction, right-of-way clearance and related projects.
- G. The CONSULTANT shall take appropriate actions to correct any deficiency determined by itself and/or the Federal Highway Administration (“FHWA”) within a reasonable time period, not to exceed ninety (90) days, in order to implement Title VI compliance in accordance with INDOT’s assurances and guidelines.
- H. During the performance of this Contract, the CONSULTANT, for itself, its assignees and successors in interest (hereinafter referred to as the "CONSULTANT") agrees as follows:
 - (1) Compliance with Regulations: The CONSULTANT shall comply with the Regulation relative to nondiscrimination in Federally-assisted programs of the Department of Transportation (hereinafter, "DOT") Title 49, Code of Federal Regulations, Part 21, as they may be amended from time to time, (hereinafter referred to as the Regulations), which are herein incorporated by reference and made a part of this Contract.
 - (2) Nondiscrimination: The CONSULTANT, with regard to the work performed by it during the Contract, shall not discriminate on the grounds of race, color, or national origin in the selection and retention of subcontractors, including procurements of materials and leases of equipment. The CONSULTANT shall not participate either directly or indirectly in the discrimination prohibited by section 21.5 of the Regulations, including employment practices when the contract covers a program set forth in Appendix B of the Regulations.
 - (3) Solicitations for SUBCONSULTANTS, Including Procurements of Materials and Equipment: In all solicitations either by competitive bidding or negotiation made by the CONSULTANT for work to be performed under a subcontract, including procurements of materials or leases of equipment, each potential SUBCONSULTANT or supplier shall be notified by the CONSULTANT of the CONSULTANT’S obligations under this Contract and the Regulations relative to nondiscrimination on the grounds of race, color, or national origin.
 - (4) Information and Reports: The CONSULTANT shall provide all information and reports required by the Regulations or directives issued pursuant thereto, and shall permit access to its books, records, accounts, other sources of information, and its facilities as may be determined by the LPA or INDOT to be pertinent to ascertain compliance with such Regulations, orders and instructions. Where any information required of a CONSULTANT is in the exclusive possession of another who fails or refuses to furnish this information the CONSULTANT shall so certify to the LPA, or INDOT as appropriate, and shall set forth what efforts it has made to obtain the information.
 - (5) Sanctions for Noncompliance: In the event of the CONSULTANT’S noncompliance with the nondiscrimination provisions of this contract, the LPA shall impose such contract sanctions as it or INDOT may determine to be appropriate, including, but not limited to:
 - (a) withholding of payments to the CONSULTANT under the Contract until the CONSULTANT complies, and/or

- (b) cancellation, termination or suspension of the Contract, in whole or in part.
- (6) Incorporation of Provisions: The CONSULTANT shall include the provisions of paragraphs (1) through (6) in every subcontract, including procurements of materials and leases of equipment, unless exempt by the Regulations, or directives issued pursuant thereto.

The CONSULTANT shall take such action with respect to any SUBCONSULTANT procurement as the LPA or INDOT may direct as a means of enforcing such provisions including sanctions for noncompliance: Provided, however, that, in the event a CONSULTANT becomes involved in, or is threatened with, litigation with a SUBCONSULTANT or supplier as a result of such direction, the CONSULTANT may request the LPA to enter into such litigation to protect the interests of the LPA, and, in addition, the CONSULTANT may request the United States to enter into such litigation to protect the interests of the United States.

13. Disputes.

- A. Should any disputes arise with respect to this Contract, the CONSULTANT and the LPA agree to act promptly and in good faith to resolve such disputes in accordance with this Section 13. Time is of the essence in the resolution of disputes.
- B. The CONSULTANT agrees that the existence of a dispute notwithstanding, it will continue without delay to carry out all of its responsibilities under this Contract that are not affected by the dispute. Should the CONSULTANT fail to continue to perform its responsibilities regarding all non-disputed work, without delay, any additional costs (including reasonable attorneys' fees and expenses) incurred by the LPA or the CONSULTANT as a result of such failure to proceed shall be borne by the CONSULTANT.
- C. If a party to this Contract is not satisfied with the progress toward resolving a dispute, the party must notify the other party of this dissatisfaction in writing. Upon written notice, the parties have ten (10) business days, unless the parties mutually agree in writing to extend this period, following the written notification to resolve the dispute. If the dispute is not resolved within ten (10) business days, a dissatisfied party may submit the dispute in writing to initiate negotiations to resolve the dispute. The LPA may withhold payments on disputed items pending resolution of the dispute.

14. Drug-Free Workplace Certification.

- A. The CONSULTANT hereby covenants and agrees to make a good faith effort to provide and maintain a drug-free workplace, and that it will give written notice to the LPA within ten (10) days after receiving actual notice that an employee of the CONSULTANT in the State of Indiana has been convicted of a criminal drug violation occurring in the CONSULTANT's workplace. False certification or violation of the certification may result in sanctions including, but not limited to, suspension of Contract payments, termination of this Contract and/or debarment of contracting opportunities with the LPA.
- B. The CONSULTANT certifies and agrees that it will provide a drug-free workplace by:
 - i. Publishing and providing to all of its employees a statement notifying their employees that the unlawful manufacture, distribution, dispensing, possession or use of a controlled substance is prohibited in the CONSULTANT's workplace and specifying the actions that will be taken against employees for violations of such prohibition;

- ii. Establishing a drug-free awareness program to inform its employees of (1) the dangers of drug abuse in the workplace; (2) the CONSULTANT's policy of maintaining a drug-free workplace; (3) any available drug counseling, rehabilitation, and employee assistance programs; and (4) the penalties that may be imposed upon an employee for drug abuse violations occurring in the workplace;
- iii. Notifying all employees in the statement required by subparagraph 14.B.i above that as a condition of continued employment, the employee will (1) abide by the terms of the statement; and (2) notify the CONSULTANT of any criminal drug statute conviction for a violation occurring in the workplace no later than five (5) days after such conviction;
- iv. Notifying in writing the LPA within ten (10) days after receiving notice from an employee under subdivision 14.B.iii(2) above, or otherwise receiving actual notice of such conviction;
- v. Within thirty (30) days after receiving notice under subdivision 14.B.iii(2) above of a conviction, imposing the following sanctions or remedial measures on any employee who is convicted of drug abuse violations occurring in the workplace: (1) take appropriate personnel action against the employee, up to and including termination; or (2) require such employee to satisfactorily participate in a drug abuse assistance or rehabilitation program approved for such purposes by a Federal, State or local health, law enforcement, or other appropriate agency; and
- vi. Making a good faith effort to maintain a drug-free workplace through the implementation of subparagraphs 14.B.i. through 14.B.v. above.

15. Employment Eligibility Verification. The CONSULTANT affirms under the penalties of perjury that he/she/it does not knowingly employ an unauthorized alien.

The CONSULTANT shall enroll in and verify the work eligibility status of all his/her/its newly hired employees through the E-Verify program as defined in IC 22-5-1.7-3. The CONSULTANT is not required to participate should the E-Verify program cease to exist. Additionally, the CONSULTANT is not required to participate if the CONSULTANT is self-employed and does not employ any employees.

The CONSULTANT shall not knowingly employ or contract with an unauthorized alien. The CONSULTANT shall not retain an employee or contract with a person that the CONSULTANT subsequently learns is an unauthorized alien.

The CONSULTANT shall require his/her/its subcontractors, who perform work under this Contract, to certify to the CONSULTANT that the SUB-CONSULTANT does not knowingly employ or contract with an unauthorized alien and that the SUB-CONSULTANT has enrolled and is participating in the E-Verify program. The CONSULTANT agrees to maintain this certification throughout the duration of the term of a contract with a SUB-CONSULTANT.

The LPA may terminate for default if the CONSULTANT fails to cure a breach of this provision no later than thirty (30) days after being notified by the LPA.

16. Force Majeure. In the event that either party is unable to perform any of its obligations under this Contract or to enjoy any of its benefits because of fire, natural disaster, acts of God, acts of war, terrorism, civil disorders, decrees of governmental bodies, strikes, lockouts, labor or supply disruptions or similar causes beyond the reasonable control of the affected party (hereinafter referred

to as a Force Majeure Event), the party who has been so affected shall immediately give written notice to the other party of the occurrence of the Force Majeure Event (with a description in reasonable detail of the circumstances causing such Event) and shall do everything reasonably possible to resume performance. Upon receipt of such written notice, all obligations under this Contract shall be immediately suspended for as long as such Force Majeure Event continues and provided that the affected party continues to use commercially reasonable efforts to recommence performance whenever and to whatever extent possible without delay. If the period of nonperformance exceeds thirty (30) days from the receipt of written notice of the Force Majeure Event, the party whose ability to perform has not been so affected may, by giving written notice, terminate this Contract.

17. **Governing Laws.** This Contract shall be construed in accordance with and governed by the laws of the State of Indiana and the suit, if any, must be brought in the State of Indiana. The CONSULTANT consents to the jurisdiction of and to venue in any court of competent jurisdiction in the State of Indiana.
18. **Liability.** If the CONSULTANT or any of its SUB-CONSULTANTS fail to comply with any federal requirement which results in the LPA's repayment of federal funds to INDOT the CONSULTANT shall be responsible to the LPA, for repayment of such costs to the extent such costs are caused by the CONSULTANT and/or its SUB-CONSULTANTS.
19. **Indemnification.** The CONSULTANT agrees to indemnify the LPA, and their agents, officials, and employees, and to hold each of them harmless, from claims and suits including court costs, attorney's fees, and other expenses caused by any negligent act, error or omission of, or by any recklessness or willful misconduct by, the CONSULTANT and/or its SUB-CONSULTANTS, if any, under this Contract, provided that if the CONSULTANT is a "contractor" within the meaning of I.C. 8-3-2-12.5, this indemnity obligation shall be limited by and interpreted in accordance with I.C. 8-23-2-12-5. The LPA shall not provide such indemnification to the CONSULTANT.
20. **Independent Contractor.** Both parties hereto, in the performance of this Contract, shall act in an individual capacity and not as agents, employees, partners, joint ventures or associates of one another. The employees or agents of one party shall not be deemed or construed to be the employees or agents of the other party for any purposes whatsoever. Neither party will assume liability for any injury (including death) to any persons, or damage to any property, arising out of the acts or omissions of the agents or employees of the other party. The CONSULTANT shall be responsible for providing all necessary unemployment and workers' compensation insurance for its employees.
21. **Insurance - Liability for Damages.**
- A. The CONSULTANT shall be responsible for the accuracy of the Services performed under this Contract and shall promptly make necessary revisions or corrections resulting from its negligence, errors or omissions without any additional compensation from the LPA. Acceptance of the Services by the LPA shall not relieve the CONSULTANT of responsibility for subsequent correction of its negligent act, error or omission or for clarification of ambiguities. The CONSULTANT shall have no liability for the errors or deficiencies in designs, drawings, specifications or other services furnished to the CONSULTANT by the LPA on which the Consultant has reasonably relied, provided that the foregoing shall not relieve the CONSULTANT from any liability from the CONSULTANT'S failure to fulfill its obligations under this Contract, to exercise its professional responsibilities to the LPA, or to notify the LPA of any errors or deficiencies which the CONSULTANT knew or should have known existed.
- B. During construction or any phase of work performed by others based on Services provided by the CONSULTANT, the CONSULTANT shall confer with the LPA when necessary for the purpose of interpreting the information, and/or to correct any negligent act, error or omission.

The CONSULTANT shall prepare any plans or data needed to correct the negligent act, error or omission without additional compensation, even though final payment may have been received by the CONSULTANT. The CONSULTANT shall give immediate attention to these changes for a minimum of delay to the project.

- C. The CONSULTANT shall be responsible for damages including but not limited to direct and indirect damages incurred by the LPA as a result of any negligent act, error or omission of the CONSULTANT, and for the LPA's losses or costs to repair or remedy construction. Acceptance of the Services by the LPA shall not relieve the CONSULTANT of responsibility for subsequent correction.
- D. The CONSULTANT shall be required to maintain in full force and effect, insurance as described below from the date of the first authorization to proceed until the LPA's acceptance of the work product. The CONSULTANT shall list both the LPA and INDOT as insureds on any policies. The CONSULTANT must obtain insurance written by insurance companies authorized to transact business in the State of Indiana and licensed by the Department of Insurance as either admitted or non-admitted insurers.
- E. The LPA, its officers and employees assume no responsibility for the adequacy of limits and coverage in the event of any claims against the CONSULTANT, its officers, employees, sub-consultants or any agent of any of them, and the obligations of indemnification in Section 19 herein shall survive the exhaustion of limits of coverage and discontinuance of coverage beyond the term specified, to the fullest extent of the law.
- F. The CONSULTANT shall furnish a certificate of insurance and all endorsements to the LPA prior to the commencement of this Contract. Any deductible or self-insured retention amount or other similar obligation under the insurance policies shall be the sole obligation of the CONSULTANT. Failure to provide insurance as required in this Contract is a material breach of Contract entitling the LPA to immediately terminate this Contract.

I. Professional Liability Insurance

The CONSULTANT must obtain and carry professional liability insurance as follows: For INDOT Prequalification **Work Types** 1.1, 12.2-12.6 the CONSULTANTS shall provide not less than \$250,000.00 professional liability insurance per claim and \$250,000.00 aggregate for all claims for negligent performance. For **Work Types** 2.2, 3.1, 3.2, 4.1, 4.2, 5.5, 5.8, 5.11, 6.1, 7.1, 8.1, 8.2, 9.1, 9.2, 10.1 – 10.4, 11.1, 13.1, 14.1 – 14.5, the CONSULTANTS shall carry professional liability insurance in an amount not less than \$1,000,000.00 per claim and \$1,000,000.00 aggregate for all claims for negligent performance. The CONSULTANT shall maintain the coverage for a period ending two (2) years after substantial completion of construction.

II. Commercial General Liability Insurance

The CONSULTANT must obtain and carry Commercial / General liability insurance as follows: For INDOT Prequalification **Work Types** 2.1, 6.1, 7.1, 8.1, 8.2, 9.1, 9.2, 10.1 - 10.4, 11.1, 13.1, 14.1 - 14.5, the CONSULTANT shall carry \$1,000,000.00 per occurrence, \$2,000,000.00 general aggregate. Coverage shall be on an occurrence form, and include contractual liability. The policy shall be amended to include the following extensions of coverage:

- 1. Exclusions relating to the use of explosives, collapse, and underground damage to property shall be removed.

2. The policy shall provide thirty (30) days notice of cancellation to LPA.
3. The CONSULTANT shall name the LPA as an additional insured.

III. Automobile Liability

The CONSULTANT shall obtain automobile liability insurance covering all owned, leased, borrowed, rented, or non-owned autos used by employees or others on behalf of the CONSULTANT for the conduct of the CONSULTANT's business, for an amount not less than \$1,000,000.00 Combined Single Limit for Bodily Injury and Property Damage. The term "automobile" shall include private passenger autos, trucks, and similar type vehicles licensed for use on public highways. The policy shall be amended to include the following extensions of coverage:

1. Contractual Liability coverage shall be included.
2. The policy shall provide thirty (30) days notice of cancellation to the LPA.
3. The CONSULTANT shall name the LPA as an additional insured.

IV. Watercraft Liability (When Applicable)

1. When necessary to use watercraft for the performance of the CONSULTANT's Services under the terms of this Contract, either by the CONSULTANT, or any SUB-CONSULTANT, the CONSULTANT or SUB-CONSULTANT operating the watercraft shall carry watercraft liability insurance in the amount of \$1,000,000 Combined Single Limit for Bodily Injury and Property Damage, including Protection & Indemnity where applicable. Coverage shall apply to owned, non-owned, and hired watercraft.
2. If the maritime laws apply to any work to be performed by the CONSULTANT under the terms of the agreement, the following coverage shall be provided:
 - a. United States Longshoremen & Harbor workers
 - b. Maritime Coverage - Jones Act
3. The policy shall provide thirty (30) days notice of cancellation to the LPA.
4. The CONSULTANT or SUB-CONSULTANT shall name the LPA as an additional insured.

V. Aircraft Liability (When Applicable)

1. When necessary to use aircraft for the performance of the CONSULTANT's Services under the terms of this Contract, either by the CONSULTANT or SUB-CONSULTANT, the CONSULTANT or SUB-CONSULTANT operating the aircraft shall carry aircraft liability insurance in the amount of \$5,000,000 Combined Single Limit for Bodily Injury and Property Damage, including Passenger Liability. Coverage shall apply to owned, non-owned and hired aircraft.
2. The policy shall provide thirty (30) days notice of cancellation to the LPA.

3. The CONSULTANT or SUB-CONSULTANT shall name the LPA as an additional insured.

22. **Merger and Modification.** This Contract constitutes the entire agreement between the parties. No understandings, agreements or representations, oral or written, not specified within this Contract will be valid provisions of this Contract. This Contract may not be modified, supplemented or amended, in any manner, except by written agreement signed by all necessary parties.

23. **Notice to Parties:** Any notice, request, consent or communication (collectively a “Notice”) under this Agreement shall be effective only if it is in writing and (a) personally delivered; (b) sent by certified or registered mail, return receipt requested, postage prepaid; or (c) sent by a nationally recognized overnight delivery service, with delivery confirmed and costs of delivery being prepaid, addressed as follows:

Notices to the LPA shall be sent to:

Neil Kopper, Senior Project Engineer
City of Bloomington
401 North Morton Street, Suite 130
Bloomington, IN 47402

Notices to the CONSULTANT shall be sent to:

Michael Eichenauer PE, Executive V.P.
8450 Westfield Boulevard, Suite 300
Indianapolis, IN 46240

or to such other address or addresses as shall be furnished in writing by any party to the other party. Unless the sending party has actual knowledge that a Notice was not received by the intended recipient, a Notice shall be deemed to have been given as of the date (i) when personally delivered; (ii) three (3) days after the date deposited with the United States mail properly addressed; or (iii) the next day when delivered during business hours to overnight delivery service, properly addressed and prior to such delivery service’s cut off time for next day delivery. The parties acknowledge that notices delivered by facsimile or by email shall not be effective.

24. **Order of Precedence; Incorporation by Reference.** Any inconsistency or ambiguity in this Contract shall be resolved by giving precedence in the following order: (1) This Contract and attachments, (2) RFP document, (3) the CONSULTANT’s response to the RFP document, and (4) attachments prepared by the CONSULTANT. All of the foregoing are incorporated fully by reference.

25. **Ownership of Documents and Materials.** All documents, records, programs, data, film, tape, articles, memoranda, and other materials not developed or licensed by the CONSULTANT prior to execution of this Contract, but specifically developed under this Contract shall be considered “work for hire” and the CONSULTANT assigns and transfers any ownership claim to the LPA and all such materials (“Work Product”) will be the property of the LPA. The CONSULTANT agrees to execute and deliver such assignments or other documents as may be requested by the LPA. Use of these materials, other than related to contract performance by the CONSULTANT, without the LPA’s prior written consent, is prohibited. During the performance of this Contract, the CONSULTANT shall be responsible for any loss of or damage to any of the Work Product developed for or supplied by INDOT and used to develop or assist in the Services provided herein while any such Work Product is in the possession or control of the CONSULTANT. Any loss or damage thereto shall be restored at

the CONSULTANT's expense. The CONSULTANT shall provide the LPA full, immediate, and unrestricted access to the Work Product during the term of this Contract. The CONSULTANT represents, to the best of its knowledge and belief after diligent inquiry and other than as disclosed in writing prior to or contemporaneously with the execution of this Contract by the CONSULTANT, that the Work Product does not infringe upon or misappropriate the intellectual property or other rights of any third party. The CONSULTANT shall not be liable for the use of its deliverables described in Appendix "A" on other projects without the express written consent of the CONSULTANT or as provided in Appendix "A". The LPA acknowledges that it has no claims to any copyrights not transferred to INDOT under this paragraph.

26. **Payments.** All payments shall be made in arrears and in conformance with the LPA's fiscal policies and procedures.
27. **Penalties, Interest and Attorney's Fees.** The LPA will in good faith perform its required obligations hereunder, and does not agree to pay any penalties, liquidated damages, interest, or attorney's fees, except as required by Indiana law in part, IC 5-17-5, I. C. 34-54-8, and I. C. 34-13-1.
28. **Pollution Control Requirements.** If this Contract is for \$100,000 or more, the CONSULTANT:
 - i. Stipulates that any facility to be utilized in performance under or to benefit from this Contract is not listed on the Environmental Protection Agency (EPA) List of Violating Facilities issued pursuant to the requirements of the Clean Air Act, as amended, and the Federal Water Pollution Control Act, as amended;
 - ii. Agrees to comply with all of the requirements of section 114 of the Clean Air Act and section 308 of the Federal Water Pollution Control Act, and all regulations and guidelines issued thereunder; and
 - iii. Stipulates that, as a condition of federal aid pursuant to this Contract, it shall notify INDOT and the Federal Highway Administration of the receipt of any knowledge indicating that a facility to be utilized in performance under or to benefit from this Contract is under consideration to be listed on the EPA Listing of Violating Facilities.
29. **Severability.** The invalidity of any section, subsection, clause or provision of this Contract shall not affect the validity of the remaining sections, subsections, clauses or provisions of this Contract.
30. **Status of Claims.** The CONSULTANT shall give prompt written notice to the LPA any claims made for damages against the CONSULTANT resulting from Services performed under this Contract and shall be responsible for keeping the LPA currently advised as to the status of such claims. The CONSULTANT shall send notice of claims related to work under this Contract to the party referred to in Paragraph 23:
31. **Sub-consultant Acknowledgement.** The CONSULTANT agrees and warrants to the LPA, that the CONSULTANT will obtain signed Sub-consultant Acknowledgement forms, from all SUB-CONSULTANTS providing Services under this Contract or to be compensated for Services through this Contract. The CONSULTANT agrees to provide signed originals of the Sub-consultant Acknowledgement form(s) to the LPA for approval prior to performance of the Services by any SUB-CONSULTANT.
32. **Substantial Performance.** This Contract shall be deemed to be substantially performed only when fully performed according to its terms and conditions and any modification or Amendment thereof.

33. **Taxes.** The LPA will not be responsible for any taxes levied on the CONSULTANT as a result of this Contract.

34. **Termination for Convenience.**

A. The LPA may terminate, in whole or in part, whenever, for any reason, when the LPA determines that such termination is in its best interests. Termination or partial termination of Services shall be effected by delivery to the CONSULTANT of a Termination Notice at least fifteen (15) days prior to the termination effective date, specifying the extent to which performance of Services under such termination becomes effective. The CONSULTANT shall be compensated for Services properly rendered prior to the effective date of termination. The LPA will not be liable for Services performed after the effective date of termination.

B. If the LPA terminates or partially terminates this Contract for any reason regardless of whether it is for convenience or for default, then and in such event, all data, reports, drawings, plans, sketches, sections and models, all specifications, estimates, measurements and data pertaining to the project, prepared under the terms or in fulfillment of this Contract, shall be delivered within ten (10) days to the LPA. In the event of the failure by the CONSULTANT to make such delivery upon demand, the CONSULTANT shall pay to the LPA any damage (including costs and reasonable attorneys' fees and expenses) it may sustain by reason thereof.

35. **Termination for Default.**

A. With the provision of twenty (20) days written notice to the CONSULTANT, the LPA may terminate this Contract in whole or in part if

(i) the CONSULTANT fails to:

1. Correct or cure any breach of this Contract within such time, provided that if such cure is not reasonably achievable in such time, the CONSULTANT shall have up to ninety (90) days from such notice to effect such cure if the CONSULTANT promptly commences and diligently pursues such cure as soon as practicable;
2. Deliver the supplies or perform the Services within the time specified in this Contract or any amendment or extension;
3. Make progress so as to endanger performance of this Contract; or
4. Perform any of the other provisions of this Contract to be performed by the CONSULTANT; or

(ii) if any representation or warranty of the CONSULTANT is untrue or inaccurate in any material respect at the time made or deemed to be made.

B. If the LPA terminates this Contract in whole or in part, it may acquire, under the terms and in the manner the LPA considers appropriate, supplies or services similar to those terminated, and the CONSULTANT will be liable to the LPA for any excess costs for those supplies or services. However, the CONSULTANT shall continue the work not terminated.

C. The LPA shall pay the contract price for completed supplies delivered and Services accepted. The CONSULTANT and the LPA shall agree on the amount of payment for manufactured materials delivered and accepted and for the protection and preservation of the property. Failure to agree will be a dispute under the Disputes clause (see Section 13). The LPA may

withhold from the agreed upon price for Services any sum the LPA determine necessary to protect the LPA against loss because of outstanding liens or claims of former lien holders.

- D. The rights and remedies of the LPA in this clause are in addition to any other rights and remedies provided by law or equity or under this Contract.
- E. **Default by the LPA.** If the CONSULTANT believes the LPA is in default of this Contract, it shall provide written notice immediately to the LPA describing such default. If the LPA fails to take steps to correct or cure any material breach of this Contract within sixty (60) days after receipt of such written notice, the CONSULTANT may cancel and terminate this Contract and institute the appropriate measures to collect monies due up to and including the date of termination, including reasonable attorney fees and expenses, provided that if such cure is not reasonably achievable in such time, the LPA shall have up to one hundred twenty (120) days from such notice to effect such cure if the LPA promptly commences and diligently pursues such cure as soon as practicable. The CONSULTANT shall be compensated for Services properly rendered prior to the effective date of such termination. The CONSULTANT agrees that it has no right of termination for non-material breaches by the LPA.
36. **Waiver of Rights.** No rights conferred on either party under this Contract shall be deemed waived, and no breach of this Contract excused, unless such waiver or excuse is approved in writing and signed by the party claimed to have waived such right. Neither the LPA's review, approval or acceptance of, nor payment for, the Services required under this Contract shall be construed to operate as a waiver of any rights under this Contract or of any cause of action arising out of the performance of this Contract, and the CONSULTANT shall be and remain liable to the LPA in accordance with applicable law for all damages to the LPA caused by the CONSULTANT's negligent performance of any of the Services furnished under this Contract.
37. **Work Standards/Conflicts of Interest.** The CONSULTANT shall understand and utilize all relevant INDOT standards including, but not limited to, the most current version of the Indiana Department of Transportation Design Manual, where applicable, and other appropriate materials and shall perform all Services in accordance with the standards of care, skill and diligence required in Appendix "A" or, if not set forth therein, ordinarily exercised by competent professionals doing work of a similar nature.
38. **No Third-Party Beneficiaries.** This Agreement is solely for the benefit of the parties hereto. Other than the indemnity rights under this Contract, nothing contained in this Agreement is intended or shall be construed to confer upon any person or entity (other than the parties hereto) any rights, benefits or remedies of any kind or character whatsoever.
39. **No Investment in Iran.** As required by IC 5-22-16.5, the CONSULTANT certifies that the CONSULTANT is not engaged in investment activities in Iran. Providing false certification may result in the consequences listed in IC 5-22-16.5-14, including termination of this Contract and denial of future state contracts, as well as an imposition of a civil penalty.
40. **Assignment of Antitrust Claims.** The CONSULTANT assigns to the State all right, title and interest in and to any claims the CONSULTANT now has, or may acquire, under state or federal antitrust laws relating to the products or services which are the subject of this Contract.

[Remainder of Page Intentionally Left Blank]

Non-Collusion.

The undersigned attests, subject to the penalties for perjury, that he/she is the CONSULTANT, or that he/she is the properly authorized representative, agent, member or officer of the CONSULTANT, that he/she has not, nor has any other member, employee, representative, agent or officer of the CONSULTANT, directly or indirectly, to the best of his/her knowledge, entered into or offered to enter into any combination, collusion or agreement to receive or pay, and that he/she has not received or paid, any sum of money or other consideration for the execution of this Contract other than that which appears upon the face of this Contract. **Furthermore, if the undersigned has knowledge that a state officer, employee, or special state appointee, as those terms are defined in IC §4-2-6-1, has a financial interest in the Contract, the Party attests to compliance with the disclosure requirements in IC §4-2-6-10.5.**

In Witness Whereof, the CONSULTANT and the LPA have, through duly authorized representatives, entered into this Contract. The parties having read and understand the forgoing terms of this Contract do by their respective signatures dated below hereby agree to the terms thereof.

CONSULTANT

LOCAL PUBLIC AGENCY

**BUTLER, FAIRMAN and SEUFERT,
INC.**

**CITY OF BLOOMINGTON, INDIANA
BOARD OF PUBLIC WORKS**

Signature
Michael D. Eichenauer, PE, VP

Signature
Kyla Cox Deckard, President

Attest:

Signature
Elizabeth Karon, Vice President

Signature
Brent A. Friend, Right-of-Way Manager

Signature
James Roach, Secretary

Signature
Margie Rice, Corporation Counsel

APPENDIX "A"

SERVICES TO BE FURNISHED BY CONSULTANT:

In fulfillment of this Contract, the CONSULTANT shall comply with the requirements of the appropriate regulations and requirements of the Indiana Department of Transportation and Federal Highway Administration.

1. BUYING

- a. The CONSULTANT shall perform the buying work covered by this Contract, designated herein as the Buyer. The Buyer shall be a licensed real estate broker in the State of Indiana or an Attorney and pre-qualified by the Indiana Department of Transportation.
- b. No work by the Buyer shall be sublet, assigned or otherwise performed by anyone other than the Buyer.
- c. The Buyer shall make every reasonable effort to acquire expeditiously the parcels listed herein.
- d. The Buyer shall perform the services under this Agreement in compliance with the most recent edition of the Indiana Department of Transportation's Real Estate Division Manual. The buyer will enter all information into the INDOT LPA-LRS system as required.
- e. All information contained in the appraisal shall be treated as confidential. The Buyer is to take all steps to ensure that he does not divulge any of this information to anyone other than a duly authorized representative of the LOCAL PUBLIC AGENCY, Indiana Department of Transportation, or Federal Highway Administration unless authorized in writing by the LOCAL PUBLIC AGENCY to reveal the information to another designated party.
- f. Should the quality and/or progress of the buying be unsatisfactory, the LOCAL PUBLIC AGENCY may terminate the services of the Buyer by giving five (5) days written notice. The earned value of the work performed shall be based upon the percentage of work completed at the time of the termination. All records of the Buyer and work completed or partially completed, shall become the property of the LOCAL PUBLIC AGENCY.

2. RIGHT-OF-WAY ENGINEERING

- a. The CONSULTANT shall revise up to 10 parcels based on alterations requested during the acquisition phase of the project, including Legal Descriptions, Land Plats, Right-of-Way Plans, and associated documents.
- b. The CONSULTANT shall update T&E Reports as needed during the acquisition phase of the project.

APPENDIX "B"

INFORMATION AND SERVICES TO BE FURNISHED BY THE LPA:

The LPA shall furnish the CONSULTANT with the following:

- A. Guarantee access to and make all provisions for the CONSULTANT to enter upon public and private lands as required for the CONSULTANT to perform the work under this Agreement.
- B. Provide all payments due the property owner(s) to the CONSULTANT.
- C. Partial mortgage release fees, cost-to-cure estimate fees, or other direct cost charges.
- D. The LPA will provide legal counsel to handle all condemnation proceedings and all eminent domain legal matters.
- E. Copies of canceled checks to support parcel certification.
- F. Provide the Appraisal Reports for the Buyer

APPENDIX "C"

SCHEDULE:

- A. No work under this Contract shall be performed by the CONSULTANT until the CONSULTANT receives a written notice to proceed from the LPA.
- B. All work by the CONSULTANT under this Contract shall be completed and delivered to the LPA for review and approval within the approximate time periods shown in the following submission schedule.
- C. All work by the CONSULTANT under this Contract shall be completed and delivered to the LPA no later than 365 calendar days after notification to proceed from the LPA.
- D. For the purposes of contract control the work shall be submitted by the CONSULTANT to the LPA for review and approval within the following approximate time periods:
 - 1. Buying Services – offers delivered within 14 days after LPA approves values and provides conveyance documents. Counteroffers will be provided to the LPA within 3 business days of receipt from landowner. If no agreement is reached after 90 days, parcel files will be delivered to the LPA for condemnation proceedings.
 - 2. Condemnation – to be completed by the LPA

The estimated letting date for this project is 10/8/2025.

APPENDIX "D"

AMOUNT OF COMPENSATION:

- A. The CONSULTANT shall receive as payment for the work performed under this Contract for a fee of \$122,100.00, unless a SUPPLEMENTAL AGREEMENT is approved in writing by the LOCAL PUBLIC AGENCY and the Indiana Department of Transportation.
- B. The CONSULTANT will be paid for the work performed under the applicable Sections of Appendix "A" of this Contract, except as provided for in this Appendix, in accordance with the following schedule, and as set out in Exhibit A:

Buying Fee *	\$ 85,500.00
Direct Expenses&Fees	\$ 6,000.00
Fee Scope Changes for Buying	\$ 8,600.00
Additional ROW Services (Hourly not to Exceed)	\$ 3,500.00
R/W Engineering Revisions (\$1,600.00 per parcel up to 10)	\$ 16,000.00
<u>T&E Report Updates (\$250.00 per parcel up to 10)</u>	<u>\$ 2,500.00</u>
TOTAL	\$122,100.00

* fees for these services will be based upon INDOT's current real estate services fee table at the time the services are rendered. Exhibit "A" indicates fees as of the time of this agreement. Any increase in fees for management and/or buying will be taken from the Fee Scope Changes for and Buying" category above.

- C. In consideration for condemnation proceedings described below the LOCAL PUBLIC AGENCY agrees to pay the Buyer on a daily basis (or on a pro rata basis for less than a day) the following sums:

	Pre-Trial Conference and Preparation	Testimony in Court as Expert Witness
Buyer	\$1,000.00 per day	\$1,000.00 per day

Pro rata basis for sub-consultants is \$150.00 per hour not to exceed the daily rate of \$1,000.00 per day. The CONSULTANT is hourly as set out in Appendix "D- 1".

		
EXHIBIT "A"		
High Street Trail - Des. No. 2200020		
City of Bloomington		
Right-of-Way Services Summary		
Parcel Number	Property Owner	Buying
1	Reformed Presbyterian Church, Trustees Of	\$ 2,250.00
2	Clay H. Carter, III & Julie A. Carter	\$ 2,250.00
3	Patricia E. Anderson	\$ 2,250.00
4	Roxanne & Bryan Smith	\$ 2,250.00
5	Robert Price & Mary Runells	\$ 2,250.00
6	Daniel Mitchell	\$ 2,250.00
7	Glen, James C & Constance Cook	\$ 2,250.00
8	Tilman Piedmont	\$ 2,250.00
9	Matthew S. & Eunice C. Donovan	\$ 2,250.00
10	Jennifer E. & Ryan W. Martin	\$ 2,250.00
11	Privet Drive LLC.	\$ 2,250.00
12	Eric M. Garabrant & Alissia A. Lauer	\$ 2,250.00
13	James P. Cripe & Laila S. Salibi-Cripe	\$ 2,250.00
14	Matthew Aaron Hassfurther	\$ 2,250.00
15	Brian J. McGough	\$ 2,250.00
16	Todd L. & Lisa Thomassen, Janet Louise	\$ 2,250.00
17	Todd L. & Lisa Thomassen	\$ 2,250.00
18	Gary M. & Judith Ann Crow	\$ 2,250.00
19	Joel A. Ybe & Ruth A. Gassman	\$ 2,250.00
20	Darrel L. & Jane F. Smith Keystone Trust	\$ 2,250.00
21	Sarah Dorwin 2007 Declaration Of Trust	\$ 2,250.00
22	Frederick R. Prall	\$ 2,250.00
23	Caroline Verdier	\$ 2,250.00
24	Rebekah Clare Sheldon	\$ 2,250.00
25	Jeffrey M. & Deborah L. Bundy	\$ 2,250.00
26	801 South High LLC.	\$ 2,250.00
27	Leo B. & Catherine A. Pilachowski	\$ 2,250.00
28	Jeremy D. & Julie A. Warren	\$ 2,250.00
29	Feisal Amin & Juliet R. Istrabadi	\$ 2,250.00
30	Anjali Kumar	\$ 2,250.00
31	Cheng Family Properties, LLC	\$ 2,250.00
32	Hussain M. & Parwin Farzad	\$ 2,250.00
33	Joseph Christine LLC.	\$ 2,250.00
34	The Evangelical Community Church Of Bloomington	\$ 2,250.00
35	Carol E. Mackay Revocable Living Trust	\$ 2,250.00
36	Richard A. McClung	\$ 2,250.00
37	Sycamore Village HOA	\$ 2,250.00
38	Sara E & James Nicholas Topoligus	\$ 2,250.00
Totals		\$ 85,500.00
Buying Parcel Scope Changes-----		\$ 8,600.00
Additional Services-----		\$ 3,500.00
Direct Expenses & Fees (Mortgage Release, etc.) -----		\$ 6,000.00
Total Right-of-Way Services -----		\$ 103,600.00

D. Method of Payment

1. The CONSULTANT shall submit invoices to the LOCAL PUBLIC AGENCY not more often than once per month during the progress of the work, for payment on account for the work completed. Minor adjustments in the categories of Buying Fee, Right-of-way Management and Miscellaneous Expenses may occur due to scope change on a parcel or unforeseen expenses. The adjustment may not exceed the total fee without a supplemental.
2. For work performed under Section A of Appendix "A" the LOCAL PUBLIC AGENCY agrees to pay the CONSULTANT for rendering such services the percentage of the work completed.
3. For work performed under the applicable Sections of Appendix "A", and upon completion of the respective work and its acceptance by the LOCAL PUBLIC AGENCY, the LOCAL PUBLIC AGENCY agrees to pay the CONSULTANT the fees established. No partial payments shall be made on a per parcel fee.
4. Additional services will be charged on an hourly basis as set out in Appendix "D-1 ". Additional services which could include additional hours by engineer or project manager involving additional parcels, utility relocations, administrative settlements, as directed by the court or Attorney in a condemnation suit, or any additional work as directed by the LPA.
5. For work performed under the Applicable Sections of Appendix "A", and upon completion of the respective work and its acceptance by the LOCAL PUBLIC AGENCY, the LOCAL PUBLIC AGENCY agrees to pay the CONSULTANT the fees established and for direct expenses incurred in order to clear title and secure the parcel. The CONSULTANT will pass through the direct cost expenses without markup. Partial payments shall be made on a percentage basis for the work performed for the Right-of-Way Management.

APPENDIX "D-1"

**Escalated Billing Rate Calculation (Short Version)
BUTLER, FAIRMAN AND SEUFERT, INC.
REGULAR AND OVERTIME BILLING RATES**

R/FORMS PROPOSALS 7-22-04

Replace the data in the yellow cells with the appropriate data for the firm and the project, using the actual labor classifications and current paid labor rates, and the proposed average (across the board) annual percentage of increase.

100.00%	Direct Labor	
164.20%	Overhead Rate	
264.20%	Labor & Overhead	
10.70%	Profit	28.27%
292.47%		
0.19%	Cost of Money	
292.66%		
\$214.02 MAXIMUM		

 Fill In yellow cells

Classification	Audited Wage Rates	Billing Rate	Escalated Billing Rates-----				NOTE	
			2022	2023	2024	2025		2026
			Annual Increase Avg. →→→→	→→→→	→→→→	→→→→		→→→→
E-V Engineer V (Principal Engineer)	73.13	214.02	214.02	214.02	214.02	214.02	\$73.13 Limit	
Overtime		214.02	214.02	214.02	214.02	214.02	\$73.13 Limit	
E-IV Engineer IV	63.45	185.69	191.26	197.00	202.91	209.00		
Overtime		185.69	191.26	197.00	202.91	209.00		
E-III Engineer III	54.43	159.29	164.07	168.99	174.06	179.28		
Overtime		159.29	164.07	168.99	174.06	179.28		
E-II Engineer II	42.68	124.91	128.66	132.52	136.50	140.60		
Overtime		124.91	128.66	132.52	136.50	140.60		
E-I Engineer I	32.19	94.21	97.04	99.95	102.95	106.04		
Overtime		110.31	113.61	117.02	120.53	124.15		
EA-III Engineer's Assistant III	55.03	161.05	165.88	170.86	175.99	181.27		
Overtime		188.57	194.22	200.05	206.05	212.23		
EA-II Engineer's Assistant II	47.47	138.93	143.10	147.39	151.81	156.36		
Overtime		162.67	167.54	172.57	177.75	183.08		
EA-I Engineer's Assistant I	29.61	86.66	89.26	91.94	94.70	97.54		
Overtime		101.47	104.51	107.64	110.87	114.20		
FP-V Field Personnel V	64.35	188.33	193.98	199.80	205.79	211.96		
Overtime		188.33	193.98	199.80	205.79	211.96		
FP-IV Field Personnel IV	56.15	164.33	169.26	174.34	179.57	184.96		
Overtime		192.41	198.18	204.12	210.25	216.56		
FP-III Field Personnel III	41.08	120.22	123.83	127.54	131.37	135.31		
Overtime		140.76	144.98	149.33	153.81	158.43		
FP-II Field Personnel II	34.54	101.08	104.11	107.23	110.45	113.76		
Overtime		118.35	121.90	125.56	129.33	133.21		
FP-I Field Personnel I	28.00	81.94	84.40	86.93	89.54	92.23		
Overtime		95.94	98.82	101.78	104.84	107.98		
SP-I Support Personnel I	20.45	59.85	61.65	63.50	65.41	67.37		
Overtime		70.08	72.18	74.34	76.57	78.87		
C-II Clerical II	38.05	111.36	114.70	118.14	121.68	125.33		
Overtime		130.39	134.30	138.33	142.48	146.75		
C-I Clerical I	25.01	73.19	75.39	77.65	79.98	82.38		
Overtime		85.70	88.27	90.91	93.64	96.45		
P-III Planner III	43.75	128.04	131.88	135.84	139.92	144.12		
Overtime		149.92	154.41	159.05	163.82	168.73		
P-II Planner II	31.61	92.51	95.29	98.15	101.09	104.12		
Overtime		108.32	111.56	114.91	118.36	121.91		
P-I Planner I	28.96	84.75	87.29	89.91	92.61	95.39		
Overtime		99.23	102.21	105.27	108.43	111.69		

			
MAN-HOUR JUSTIFICATION			
High Street Trail - Des. No. 2200020			
City of Bloomington			
Right-of-Way Engineering Revisions (if required)			
DESCRIPTION	MAN-HOURS BY CLASSIFICATION		LABOR COSTS
	E-III	EA-I	PER TASK
PROJECT MANAGEMENT			
Coordination with Client and Design Team	6.00		\$1,013.94
Coordination with Subconsultants / populate LRS	4.00	3.00	\$951.78
TOTAL PROJECT MANAGEMENT			\$1,900.00
CALCULATIONS / DESCRIPTIONS / LAND PLATS			
Calculations	12.00		\$2,027.88
Area Comps / Documentation	12.00		\$2,027.88
Descriptions	26.00		\$4,393.74
Land Plats / Markup Plans for Acquisition		23.00	\$2,114.62
TOTAL CALCULATIONS / DESCRIPTIONS / LAND PLATS			\$10,500.00
R/W PLANS			
Drafting		30.00	\$2,758.20
QC/QA	5.00		\$844.95
TOTAL R/W PLANS			\$3,600.00
Rates	65.00	56.00	
2024	\$168.99	\$91.94	
	\$10,984.35	\$5,148.64	
Total Direct Labor	\$16,132.99		
T&E Report Update	\$2,500.00		
	Fee Summary		Fee
	Task	Total	Per Parcel
	Title Updates	\$ 2,500.00	\$ 250.00
	Project Management	\$ 1,900.00	
	Legals / Land Plats	\$ 10,500.00	\$ 1,600.00
	R/W Plans	\$ 3,600.00	
	Total	\$ 18,500.00	



Board of Public Works Staff Report

Project/Event: Change Order #2, Adams St Sidewalk Project
Petitioner/Representative: Engineering Department
Staff Representative: Jason Kerr
Date: May 8th, 2024

Report: This project is for construction of new sidewalk along the west side of Adams St from Kirkwood Ave to Fountain Dr. There was a retaining wall being installed on the project. There had to be suitable soil under the wall for stabilization. The area below the footer was undercut to adequately compacted soil for the construction. The contract price was \$371,875.96, the change order amount from doing the undercut is \$11,762.30 bringing the new contract price to \$383,638.26.

City of Bloomington Contract and Purchase Justification Form

Vendor: Crider and Crider

Contract Amount: \$383,638.26

This form should be completed and attached to the contract documents and forwarded to the Legal Department Attorney assigned to your Department. Contracts will not be approved by the Controller if a completed form is not included with the contract documents.

PURCHASE INFORMATION

1. Check the box beside the procurement method used to initiate this procurement: (Attach a quote or bid tabulation if applicable)

<input type="checkbox"/> Request for Quote (RFQ)	<input type="checkbox"/> Request for Proposal (RFP)	<input type="checkbox"/> Sole Source	<input checked="" type="checkbox"/> Not Applicable (NA)
<input type="checkbox"/> Invitation to Bid (ITB)	<input type="checkbox"/> Request for Qualifications (RFQu)	<input type="checkbox"/> Emergency Purchase	

2. List the results of procurement process. Give further explanation where requested. Yes No

# of Submittals: N/A	Yes	No		
Met city requirements?	<input checked="" type="checkbox"/>	<input type="checkbox"/>	Was the lowest cost selected? (If no, please state below why it was not.)	<input checked="" type="checkbox"/> <input type="checkbox"/>
Met item or need requirements?	<input checked="" type="checkbox"/>	<input type="checkbox"/>	This is a change order in compliance with the contract documents.	
Was an evaluation team used?	<input type="checkbox"/>	<input checked="" type="checkbox"/>		
Was scoring grid used?	<input type="checkbox"/>	<input checked="" type="checkbox"/>		
Were vendor presentations requested?	<input type="checkbox"/>	<input checked="" type="checkbox"/>		

3. State why this vendor was selected to receive the award and contract:

Contract Price \$371,875.96
 Change Order #2 + \$11,762.30

Final Contract \$383,638.26

Jason Kerr

Project Manager

Engineering

Print/Type Name

Print/Type Title

Department



City of Bloomington, Indiana

Change Order Details

Adams St Sidewalk (Kirkwood to Fountain)

Description	This project will construct a sidewalk on the west side of Adams Street from Kirkwood Ave to Fountain Drive, including accessible curb ramps. There will be construction at the intersection of 8th St and Fountain Drive as well. This will include installing a new sidewalk along 8th St, connecting two sidewalks in that area. Accessible curb ramps are included at 8th St. The project was programmed through the Council Sidewalk Committee and has received additional funding support with a Community Development Block Grant of \$140,000.
Prime Contractor	Crider & Crider, Inc. 1900 Liberty Drive Bloomington, IN 47403
Change Order	2
Status	Pending
Date Created	04/30/2024
Type	Other
Summary	Under Cut For Retaining Wall
Change Order Description	The retaining wall subbase had to be under cut to get to soil that had the correct compaction needed for the retaining wall. This included dirt removal and addition of 53's and 8's to fill in the excavated area. There are no additional days with this change order. 1. 100 tons of 53's 2. 40 tons of #8 stone 3. 50 CYs of excavated material
Awarded Project Amount	\$369,683.00
Authorized Project Amount	\$371,875.96
Change Order Amount	\$11,762.30
Revised Project Amount	\$383,638.26

New Items

Line Number	Item ID	Unit	Quantity	Unit Price	Extension
Section: 1 - Description					
0040	303-01180	TON	100.000	\$76.000	\$7,600.00
COMPACTED AGGREGATE NO. 53					
Reason: Retaining Wall Undercut					
0050	203-02000	CYS	50.000	\$35.000	\$1,750.00
EXCAVATION, COMMON:					
Reason: Retaining Wall Undercut					
0060	301-12233	CYS	37.400	\$64.500	\$2,412.30
COMPACTED AGGREGATE NO. 8					
Reason: Retaining Wall undercut					
3 items					Total: \$11,762.30

Not valid until signed by the Engineer, Contractor, and Owner

Engineer

Contractor

Board of Public Works

Title

Title

Title

Date

Date

Date



Board of Public Works Staff Report

Project/Event: Permit Extensions for AEG Fiber Work
Staff Representative: Alex Gray
Petitioner/Representative: Bret Simons
Date: May 21st, 2024

Report: AEG is requesting the extension of previously approved permits with this Board meeting consisting of 11 permit zones. The permit extensions are due to scheduling changes that AEG has had to enact in their fiber install work within the City's ROW. For this quarter the Board will see a series of permits in the coming meetings to extend so that AEG can be caught up with their scheduling changes. The permits that are being requested for extension at this Board meeting are below.

Each of the permits on the list supplied by AEG has an expected completion date next to the permit number and road designation. In case of weather or other delays all of the permits have a final completion date, including splicing and power to the system, of August 15th.

The areas noted are areas consisting of College Mall Rd near E Moores Pike, W Fountain Dr area, N Kinser Pike at W Gourley Pike area, W 17th St, north of IU's campus around E 16th St, Rosehill Cemetery and W Kirkwood Ave neighborhood, Reverend Ernest Butler Park neighborhood, S Maxwell St towards Monroe County's YMCA, and near City Hall and downtown.

The areas of N Williams St and S Maxwell St were extended at the last Board meeting, but were included for completeness and to prevent confusion on what is or is not active.



P.O. Box 349 | Buford, Georgia 30515

Main Office: (706)654-2298

www.aeg.cc

To: City of Bloomington – Engineering Department

Subject: City of Bloomington Right of Way Application Extension

Dear Board Members,

AEG is respectfully requesting an extension to access the ROWs on expired permits in the city.

We are asking for extensions on the following permits. We were unable to finish or start work in these areas due to unforeseen circumstances (Pole Co-op not responding in a timely manner / Weather). All work will be completed in these areas by Aug 15th, 2024.

BLC01a-F12_S College Mall Rd	Completion date June 13th
BLN01b-F13_N Crescent Rd	Completion date July 27th
BLN01a-F06_Hoosier Court Ave	Completion date July 13th
BL24 - E 16th St (BLN01a-F03)	Completion date July 13th
BLN01a-F14_N Lincoln St	Completion date July 13th
BLN01a-F02_E 19th St	Completion date July 27th
BLN01b-F12_N Hay St	Completion date July 27th
BLN01b-F11_N Williams St	Completion date Aug 3rd
BLC02a-F14_S Maxwell St	Completion date Aug 3rd
BLN01b-F10_N Morton St	Completion date Aug 10th
BLN01b-F09_N Lincoln St	Completion date Aug 15th

Bret Simons
Engineering Permit Team Lead
Atlantic Engineering Group

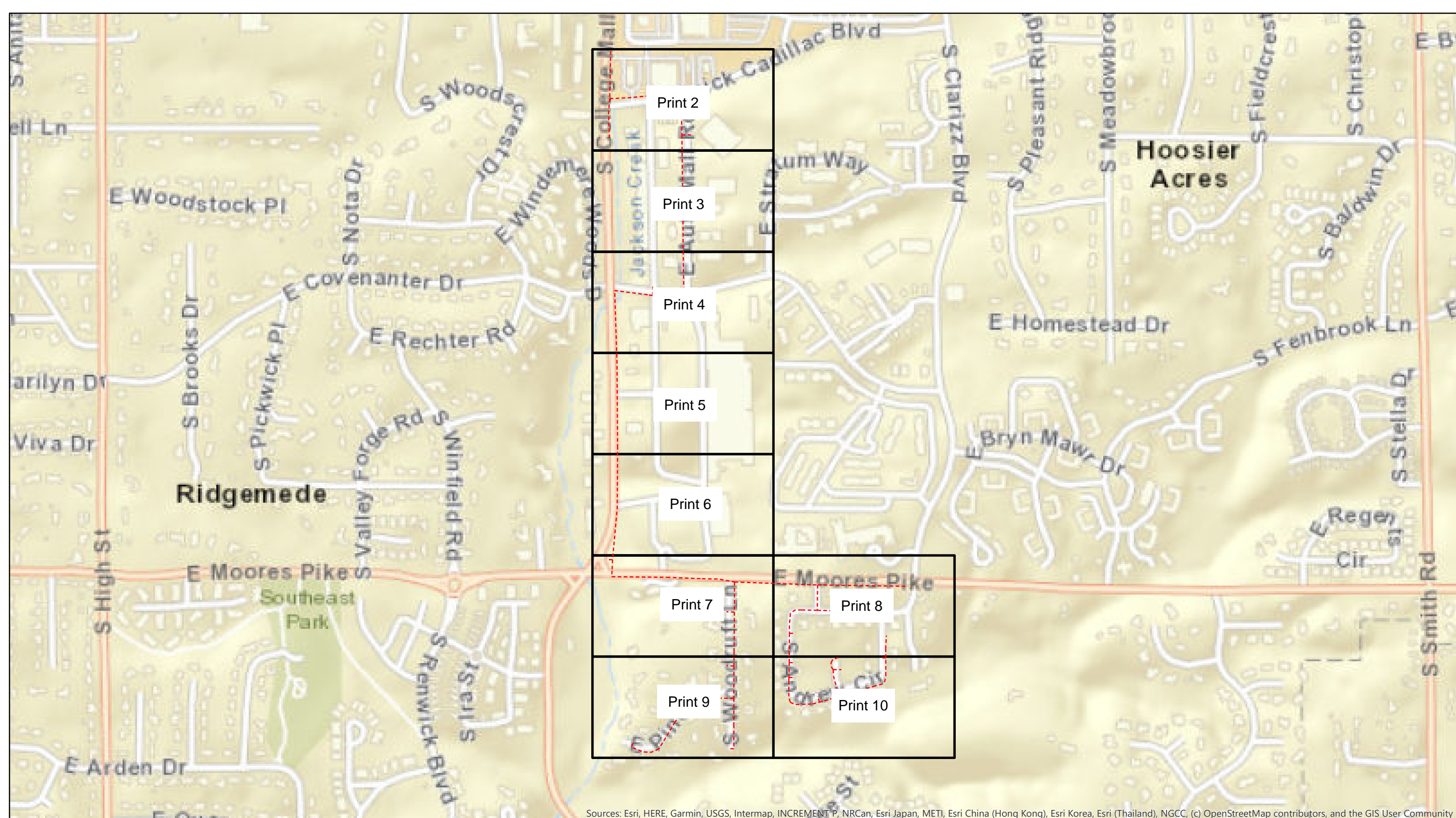

Sources: Esri, HERE, Garmin, USGS, Intermap, INCREMENT P, NRCan, Esri Japan, METI, Esri China (Hong Kong), Esri Korea, Esri (Thailand), NGCC, (c) OpenStreetMap contributors, and the GIS User Community



Legend BLC01a-F12 - S College Mall Rd

- - - Conduit
- Grids



City of Bloomington, IN Permit:
Design View

INI	BY	DATE	DESCRIPTION

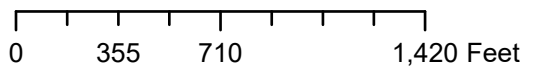

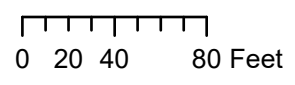
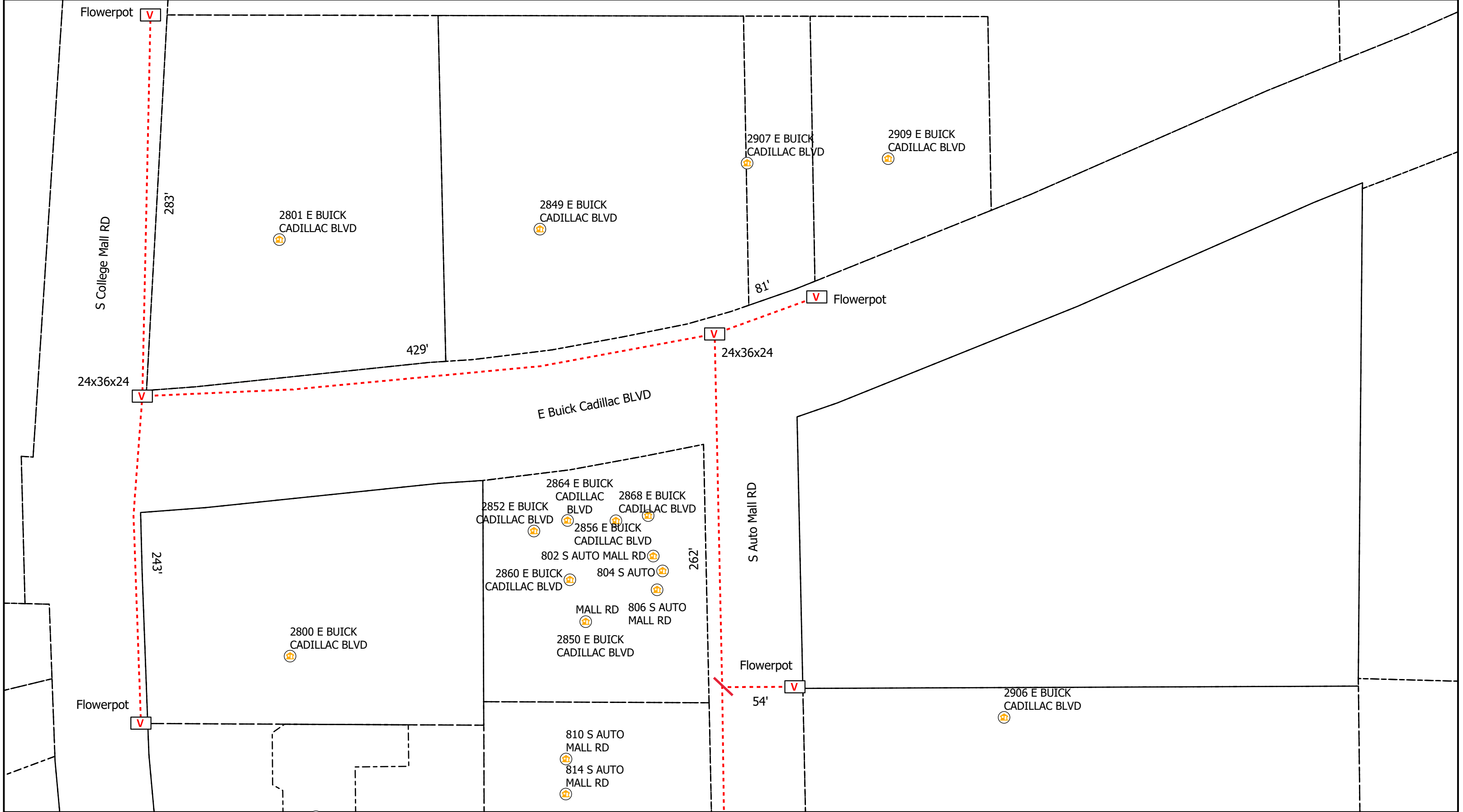

Legend

- Poles
- V Vaults
- Overhead Strand
- Conduit
- Bloomington_Parcels
- R Risers
- A Address
- Y Anchor
- ← Sidewalk
- Grids

All Flowerpots 12" DIA



City of Bloomington, IN Permit:
Design View

INI	BY	DATE	DESCRIPTION



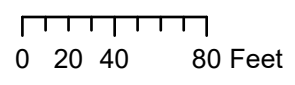
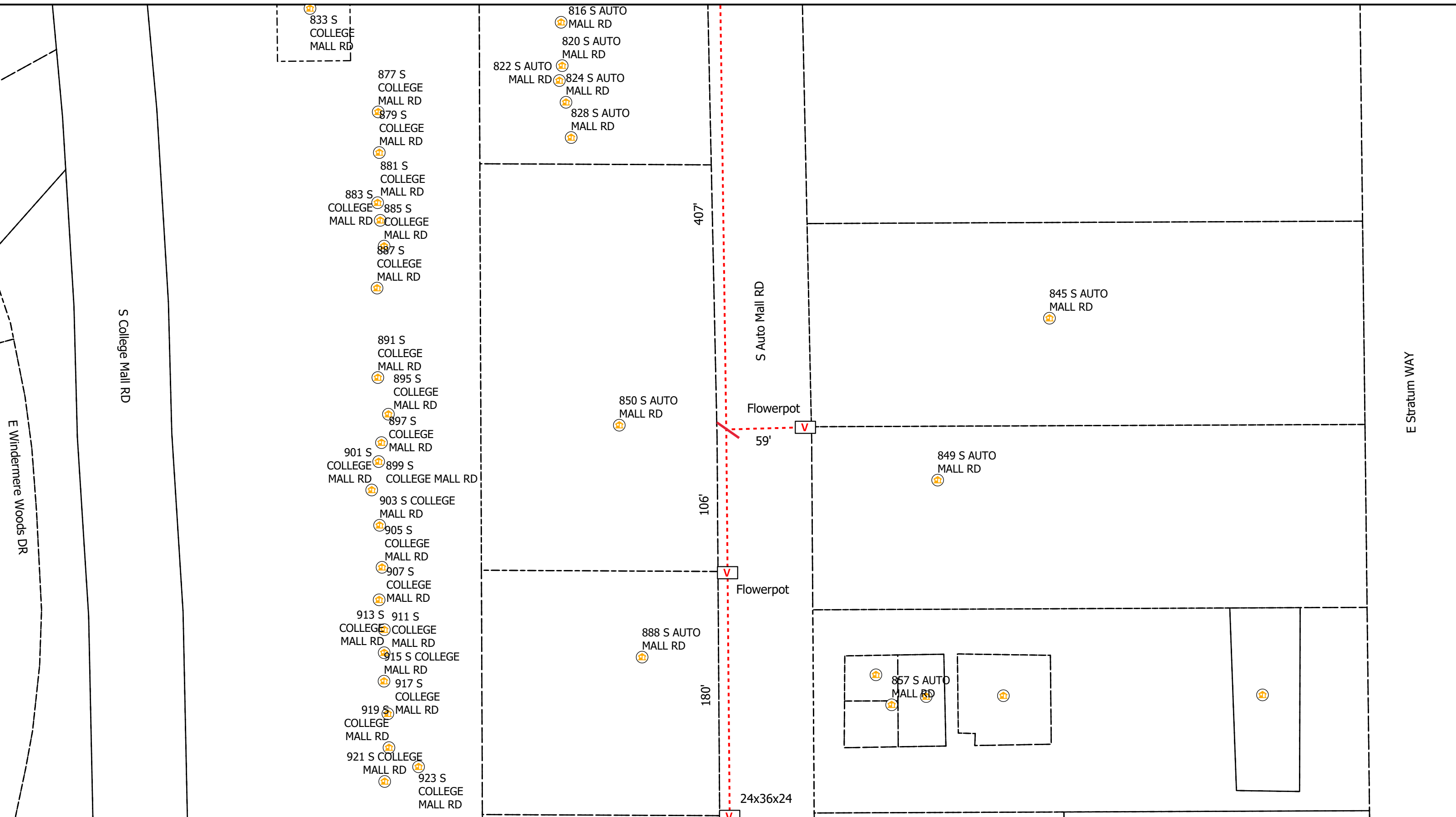

Legend

- Poles
- Vaults
- Overhead Strand
- Conduit
- Bloomington_Parcels
- Risers
- Address
- Anchor
- Sidewalk
- Grids

All Flowerpots 12" DIA



City of Bloomington, IN Permit:
Design View

INI	BY	DATE	DESCRIPTION



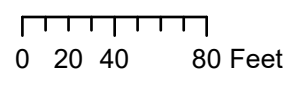
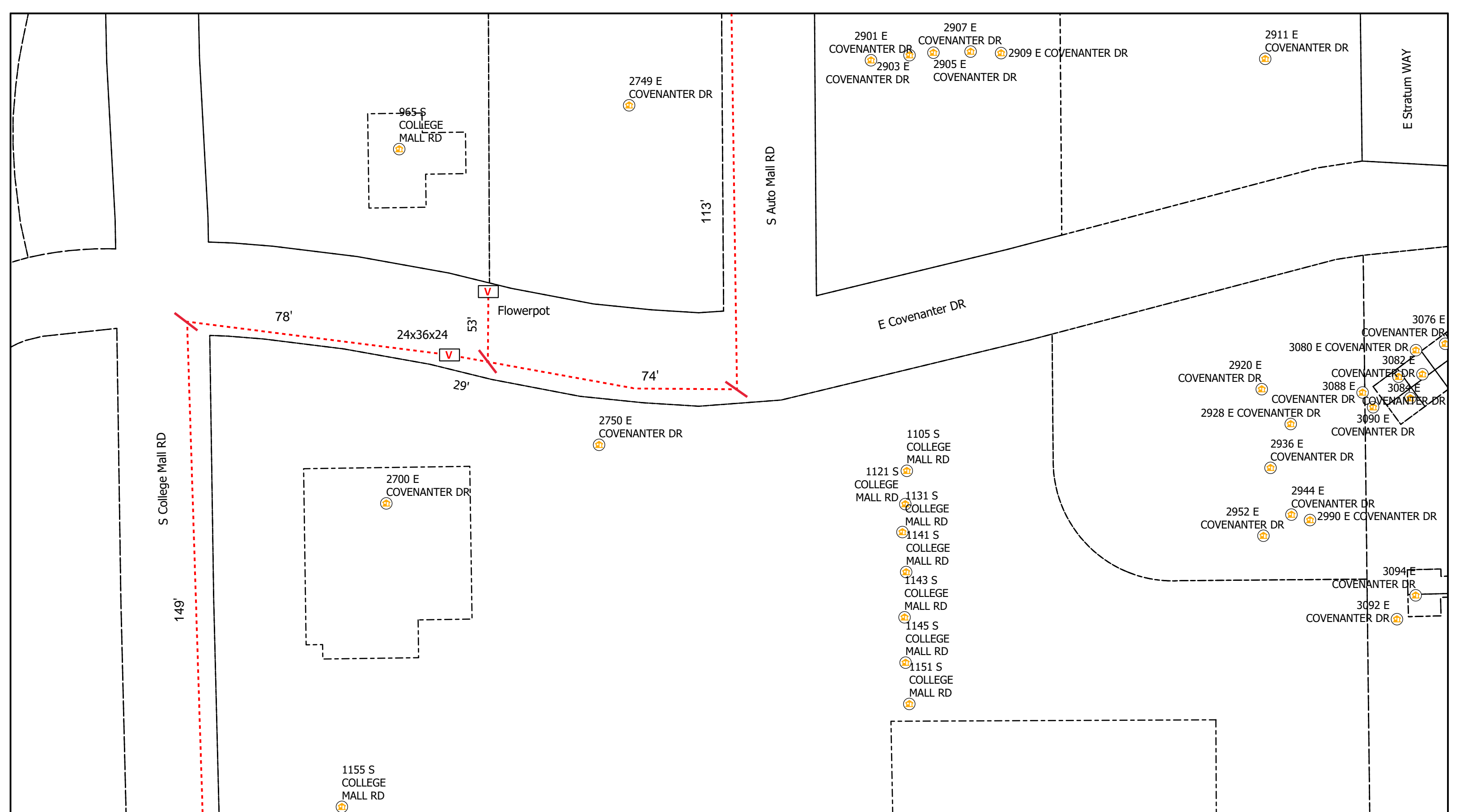

Legend

- Poles
- Vaults
- Overhead Strand
- Conduit
- Bloomington_Parcels
- R Risers
- A Address
- Anchor
- Sidewalk
- Grids

All Flowerpots 12" DIA



City of Bloomington, IN Permit:
Design View

INI	BY	DATE	DESCRIPTION



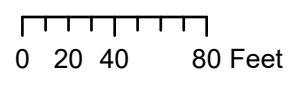
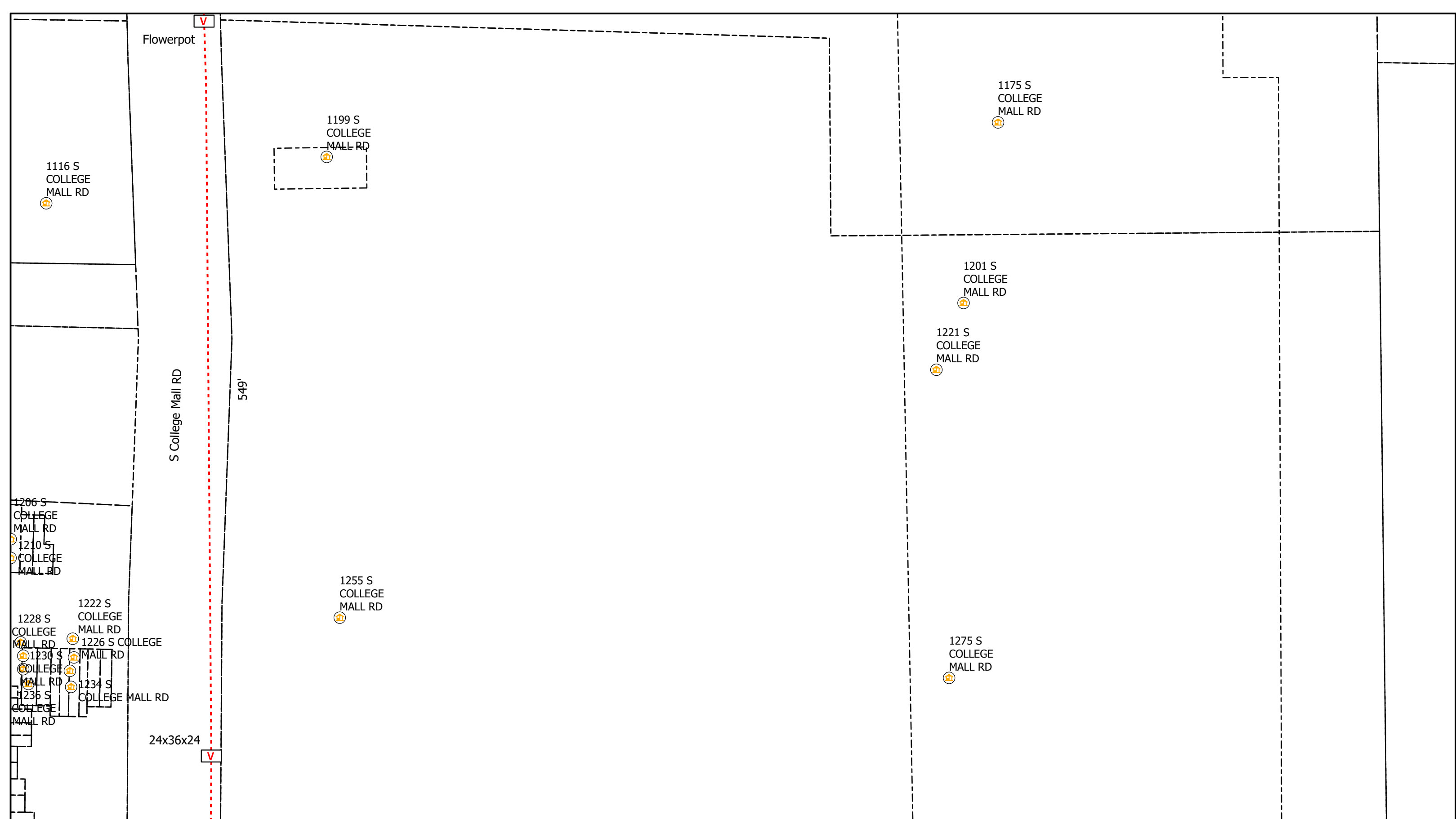

Legend

- Poles
- Vaults
- Overhead Strand
- Conduit
- Bloomington_Parcels
- Risers
- Address
- Anchor
- Sidewalk
- Grids

All Flowerpots 12" DIA



City of Bloomington, IN Permit:
Design View

INI	BY	DATE	DESCRIPTION



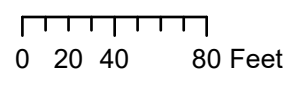
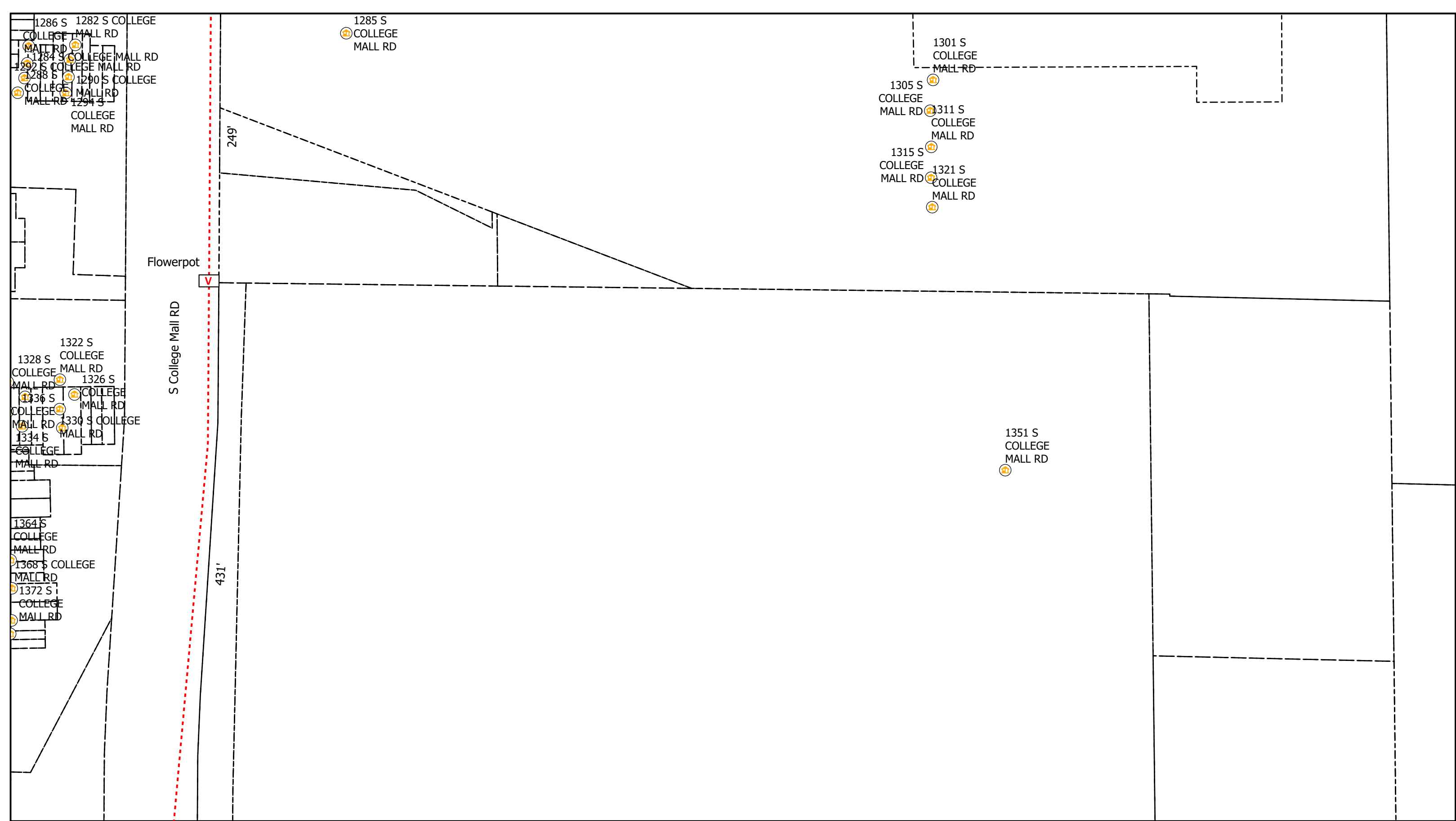

Legend

- Poles
- Vaults
- Overhead Strand
- Conduit
- Bloomington_Parcels
- R Risers
- H Address
- Anchor
- Sidewalk
- Grids

All Flowerpots 12" DIA



City of Bloomington, IN Permit:
Design View

INI	BY	DATE	DESCRIPTION



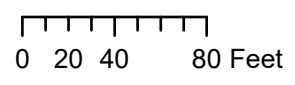
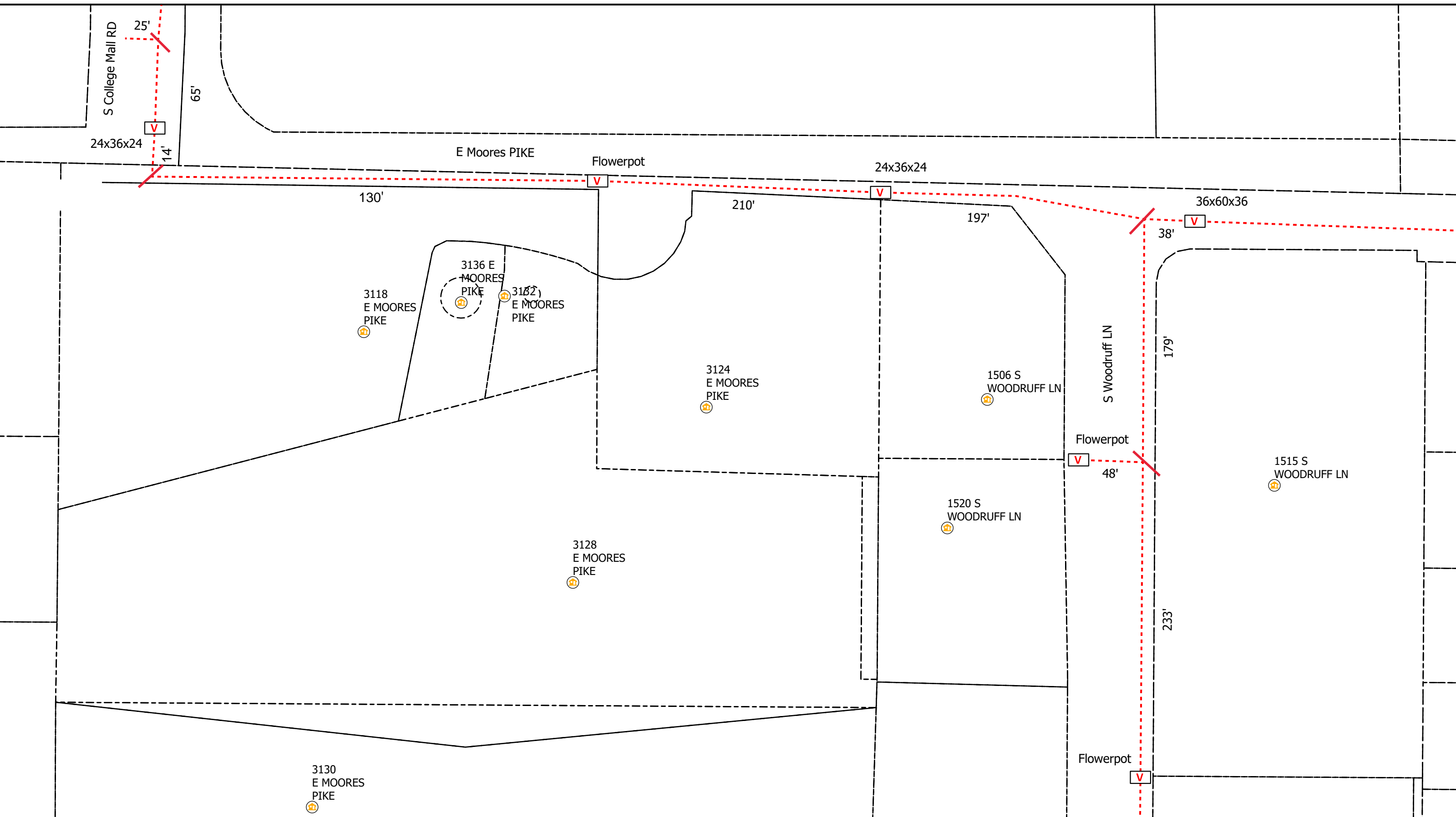

Legend

- Poles
- V Vaults
- Overhead Strand
- - - Conduit
- Bloomington_Parcels
- R Risers
- A Address
- Y Anchor
- ← Sidewalk
- Grids

All Flowerpots 12" DIA



City of Bloomington, IN Permit:
Design View

INI	BY	DATE	DESCRIPTION



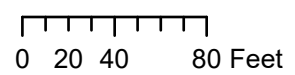
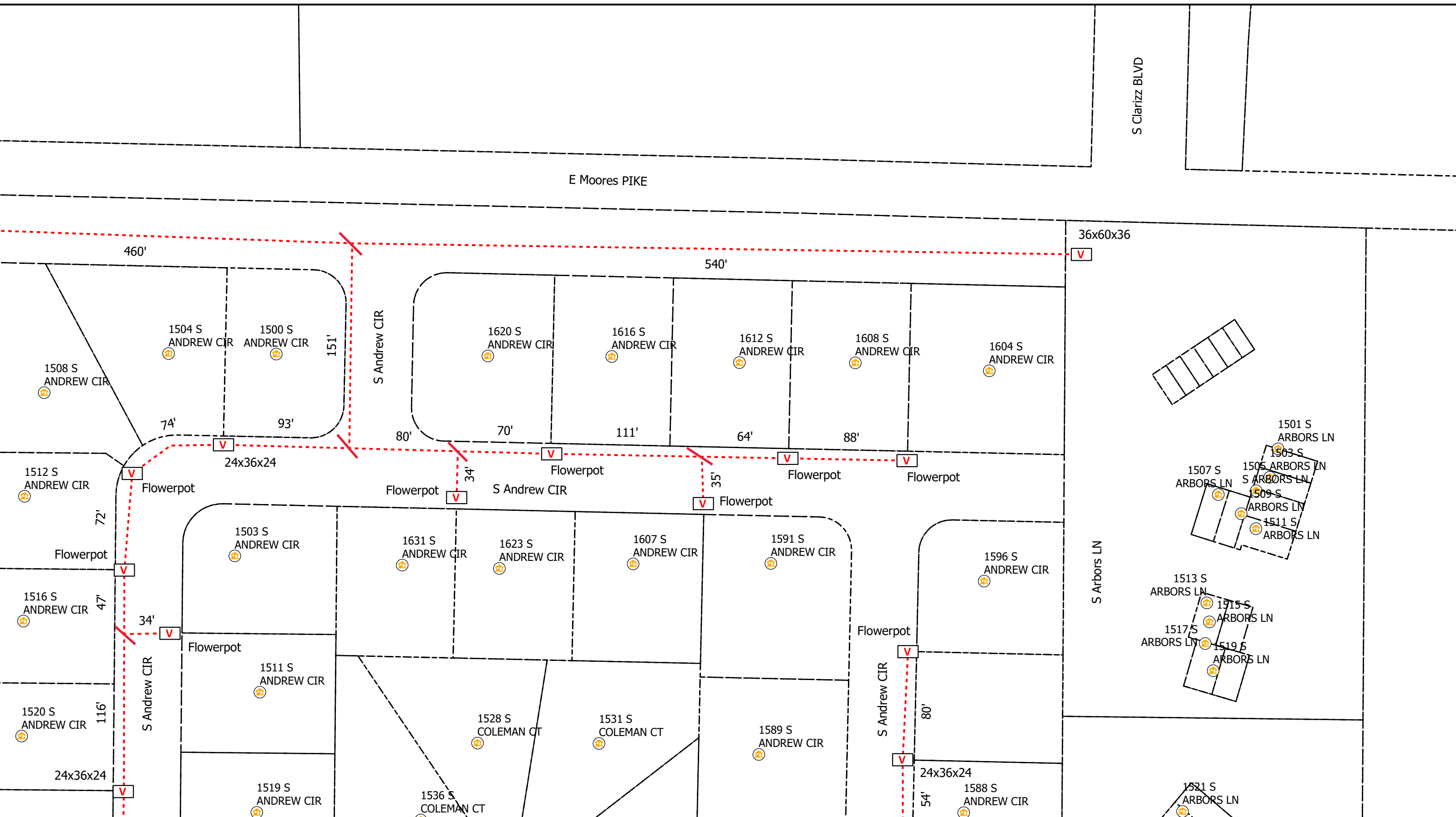

Legend

- Poles
- Vaults
- Overhead Strand
- Conduit
- Bloomington_Parcels
- Risers
- Address
- Anchor
- Sidewalk
- Grids

All Flowerpots 12" DIA



City of Bloomington, IN Permit:
Design View

INI	BY	DATE	DESCRIPTION



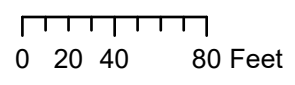
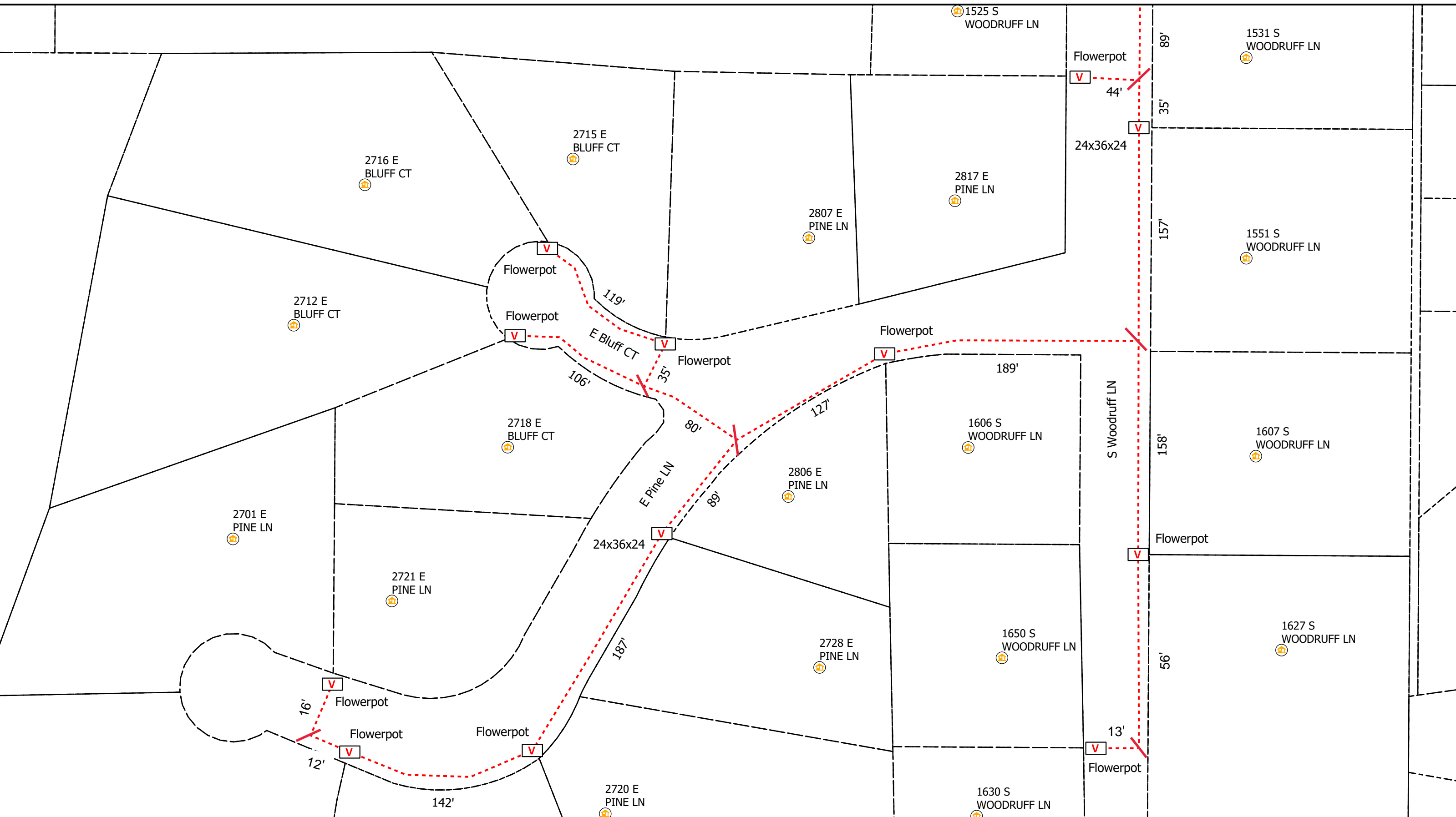

Legend

- Poles
- V Vaults
- Overhead Strand
- - - Conduit
- Bloomington_Parcels
- Ⓡ Risers
- Ⓜ Address
- Y Anchor
- ← Sidewalk
- Grids

All Flowerpots 12" DIA



City of Bloomington, IN Permit:
Design View

INI	BY	DATE	DESCRIPTION



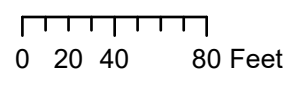
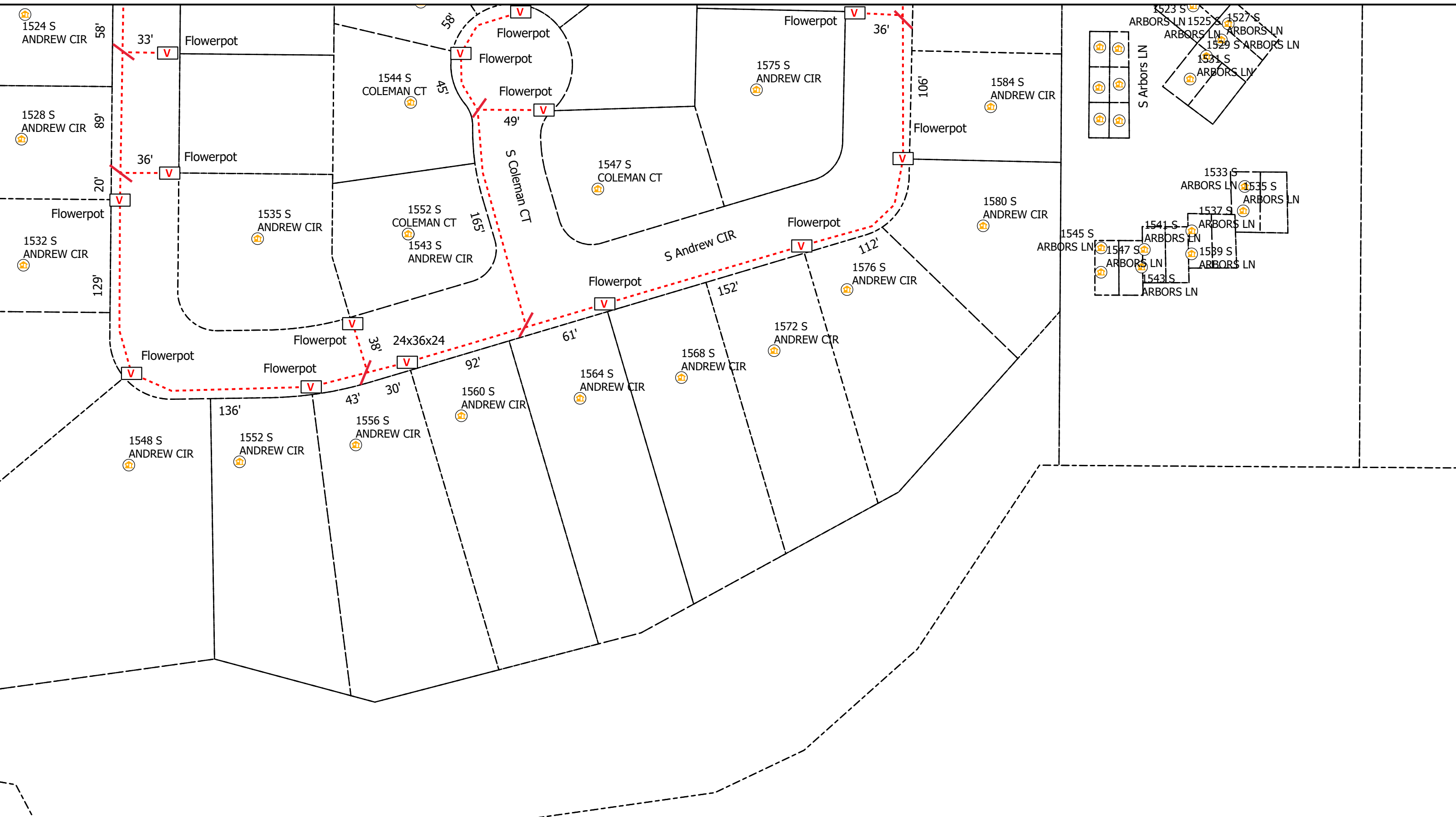

Legend

- Poles
- Vaults
- Overhead Strand
- Conduit
- Bloomington_Parcels
- Risers
- Address
- Anchor
- Sidewalk
- Grids

All Flowerpots 12" DIA



City of Bloomington, IN Permit:
Design View

INI	BY	DATE	DESCRIPTION



CONCEPTUAL SIDE VIEW

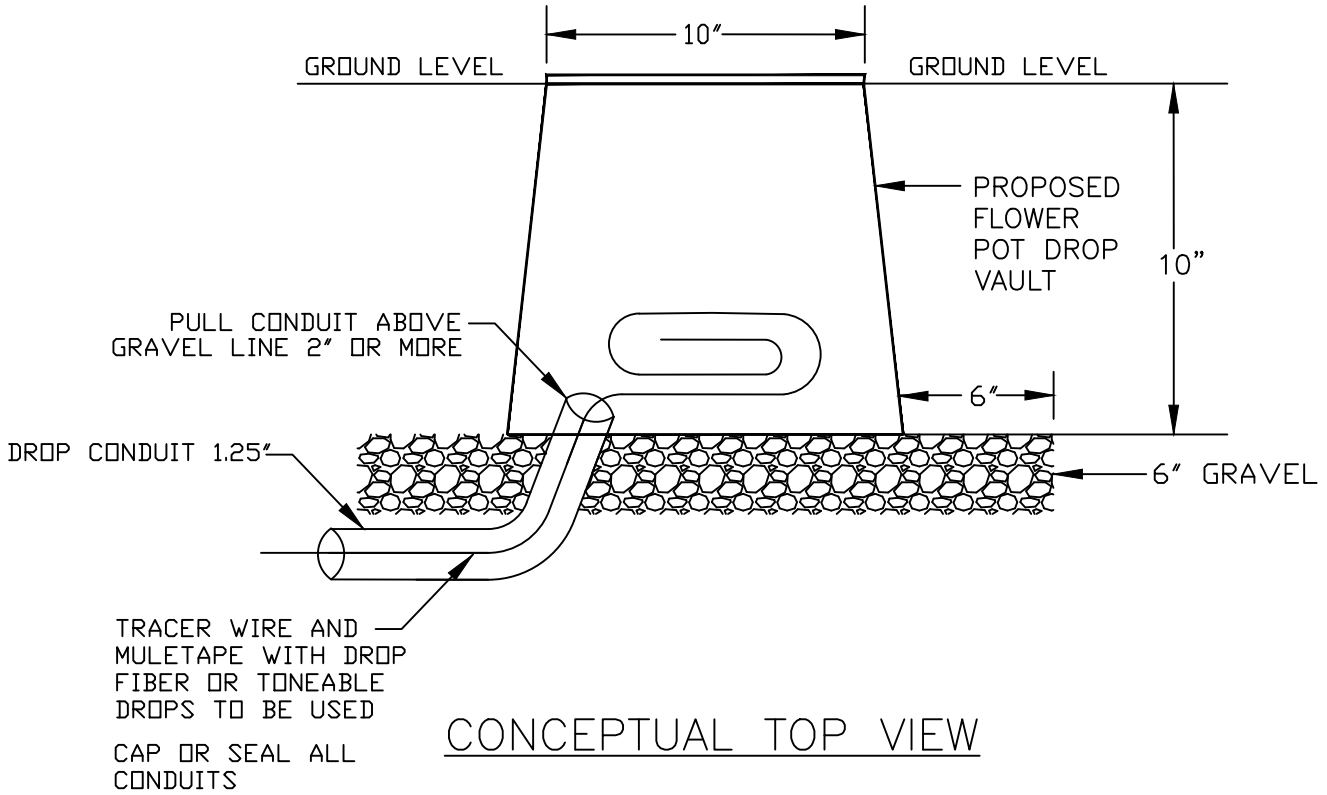

CONCEPTUAL TOP VIEW

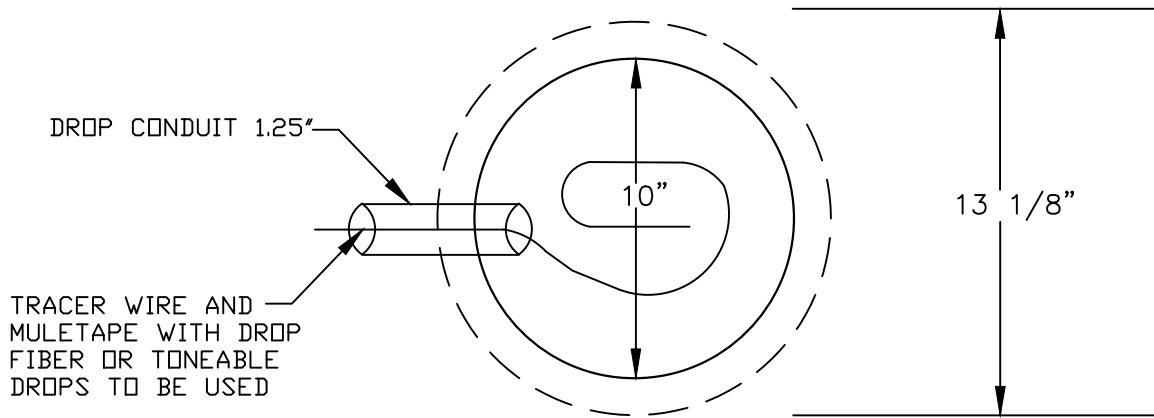

FLOWER POT

30"x48" PC UNIT, 2PC TIER 15/22
 18", 24", and 36" HEIGHT



AMERICAN POLYMER COMPANY

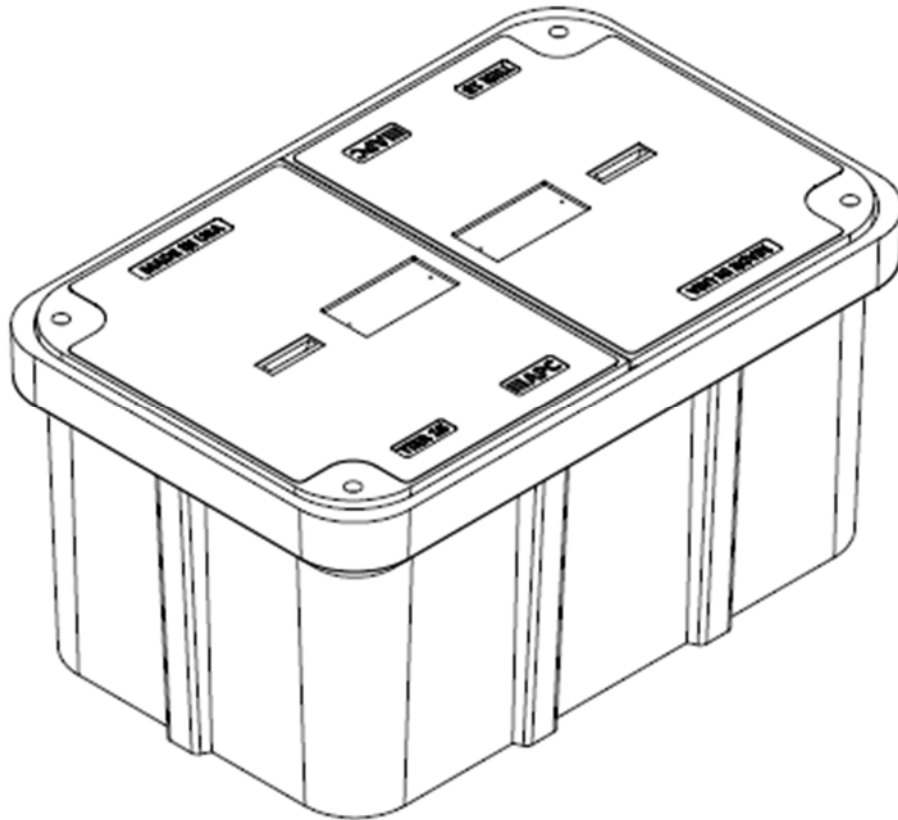

Description	Nominal Size	ANSI Tier	Part Number	Estimated Weight
PC Unit – TIER 15	30"x48"x18"	Tier 15	P304818HU15...	460 lbs.
PC Unit – TIER 22	30"x48"x18"	Tier 22	P304818HU22...	525 lbs.
PC Unit – TIER 15	30"x48"x24"	Tier 15	P304824HU15...	510 lbs.
PC Unit – TIER 22	30"x48"x24"	Tier 22	P304824HU22...	575 lbs.
PC Unit – TIER 15	30"x48"x36"	Tier 15	P304836HU15...	615 lbs.
PC Unit – TIER 22	30"x48"x36"	Tier 22	P304836HU22...	680 lbs.



30"x48" PC UNIT, 2PC TIER 15/22

18", 24", and 36" HEIGHT



AMERICAN POLYMER COMPANY

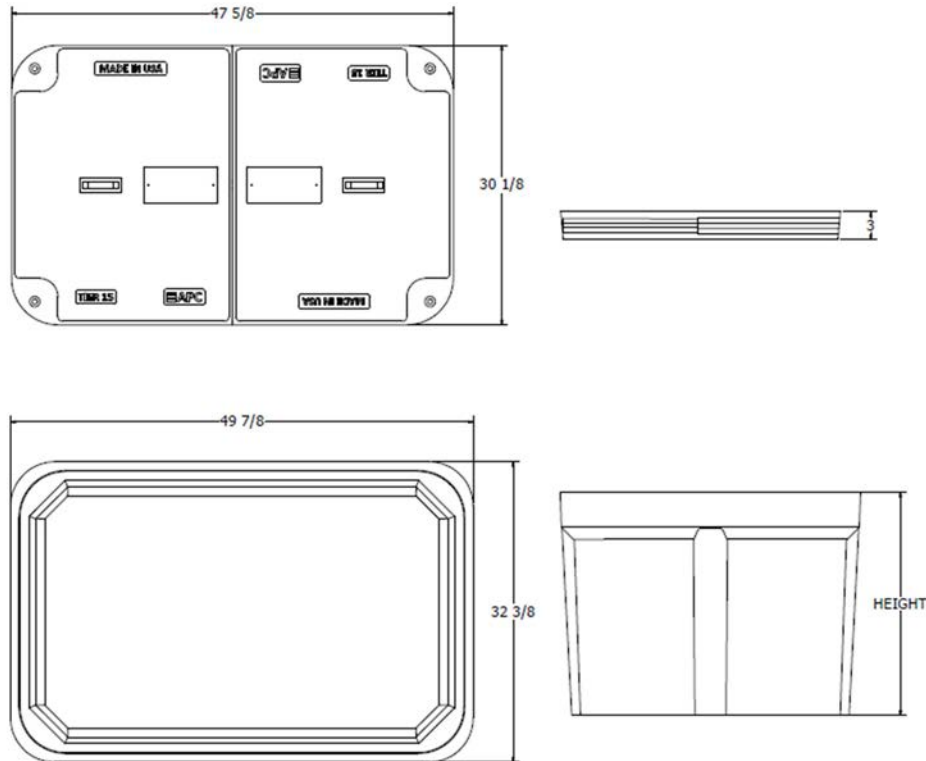

Components	Nominal Size	ANSI Tier	Part Number	Estimated Weight
Replacement Box	30"x48"x18"	Tier 22	P304818B22	185 lbs.
Replacement Box	30"x48"x24"	Tier 22	P304824B22	235 lbs.
Replacement Box	30"x48"x36"	Tier 22	P304836B22	340 lbs.
Replacement Lids - T15	30"x48" (half)	Tier 15	Various	150 lbs.
Replacement Lids - T22	30"x48" (half)	Tier 22	Various	170 lbs.

Bolt options

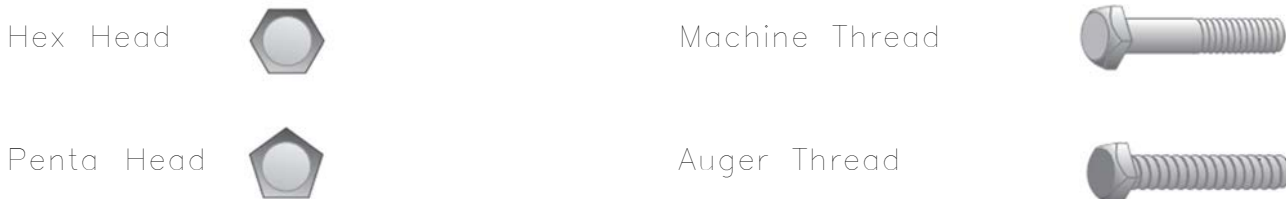

24"x36" PC UNIT, TIER 15/22
 18", 24", 30", and 36" HEIGHT



AMERICAN POLYMER COMPANY

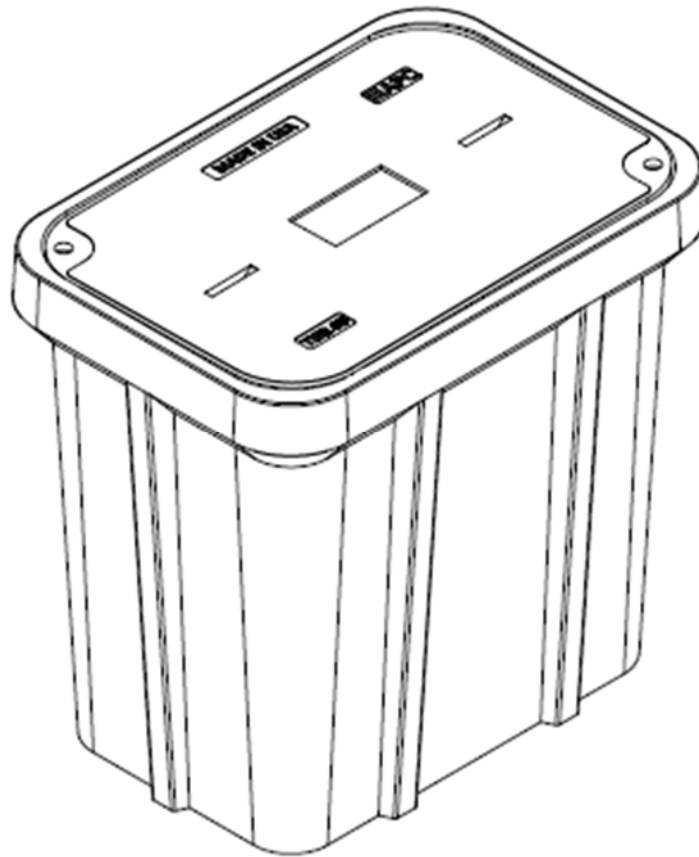

Description	Nominal Size	ANSI Tier	Part Number	Estimated Weight
PC Unit – TIER 15	24x36"x18"	Tier 15	P243618U15...	335 lbs.
PC Unit – TIER 22	24x36"x18"	Tier 22	P243618U22...	355 lbs.
PC Unit – TIER 15	24x36"x24"	Tier 15	P243624U15...	365 lbs.
PC Unit – TIER 22	24x36"x24"	Tier 22	P243624U22...	385 lbs.
PC Unit – TIER 15	24x36"x30"	Tier 15	P243630U15...	395 lbs.
PC Unit – TIER 22	24x36"x30"	Tier 22	P243630U22...	415 lbs.
PC Unit – TIER 15	24x36"x36"	Tier 15	P243636U15...	425 lbs.
PC Unit – TIER 22	24x36"x36"	Tier 22	P243636U22...	445 lbs.



24"x36" PC UNIT, TIER 15/22

18", 24", 30", and 36" HEIGHT



AMERICAN POLYMER COMPANY

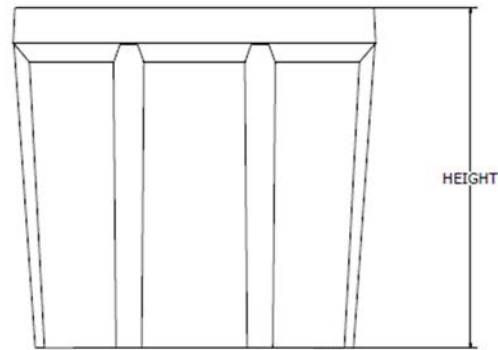
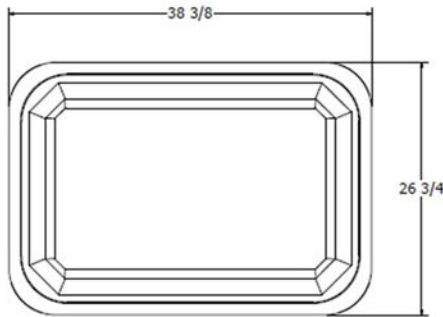
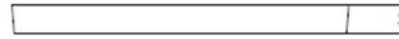
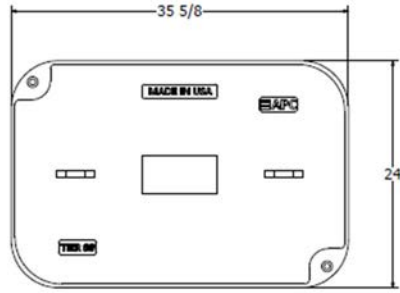

Components	Nominal Size	ANSI Tier	Part Number	Estimated Weight
Replacement Box	24"x36"x18"	Tier 22	P243618B22	165 lbs.
Replacement Box	24"x36"x24"	Tier 22	P243624B22	195 lbs.
Replacement Box	24"x36"x30"	Tier 22	P243630B22	225 lbs.
Replacement Box	24"x36"x36"	Tier 22	P243636B22	255 lbs.
Replacement Lids - T15	24"x36"	Tier 15	Various	170 lbs.
Replacement Lids - T22	24"x36"	Tier 22	Various	190 lbs.

Bolt options

Hex Head



Machine Thread



Penta Head



Auger Thread



17"x30" PC UNIT, TIER 15/22
 12", 18", 24", and 30" HEIGHT



AMERICAN POLYMER COMPANY

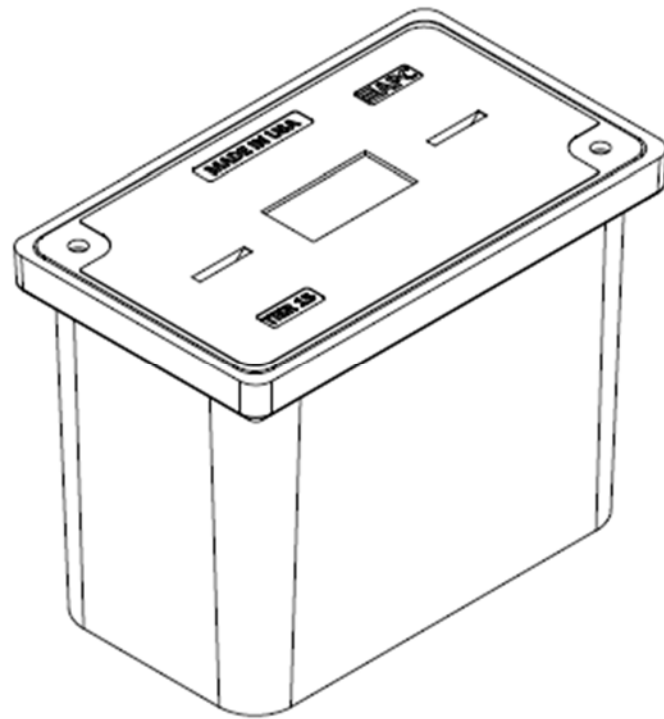

Description	Nominal Size	ANSI Tier	Part Number	Estimated Weight
PC Unit – TIER 15	17"x30"x12"	Tier 15	P173012U15...	138 lbs.
PC Unit – TIER 22	17"x30"x12"	Tier 22	P173012U22...	147 lbs.
PC Unit – TIER 15	17"x30"x18"	Tier 15	P173018U15...	172 lbs.
PC Unit – TIER 22	17"x30"x18"	Tier 22	P173018U22...	181 lbs.
PC Unit – TIER 15	17"x30"x24"	Tier 15	P173024U15...	192 lbs.
PC Unit – TIER 22	17"x30"x24"	Tier 22	P173024U22...	201 lbs.
PC Unit – TIER 15	17"x30"x30"	Tier 15	P173030U15...	217 lbs.
PC Unit – TIER 22	17"x30"x30"	Tier 22	P173030U22...	226 lbs.



17"x30" PC UNIT, TIER 15/22

12", 18", 24", and 30" HEIGHT



AMERICAN POLYMER COMPANY

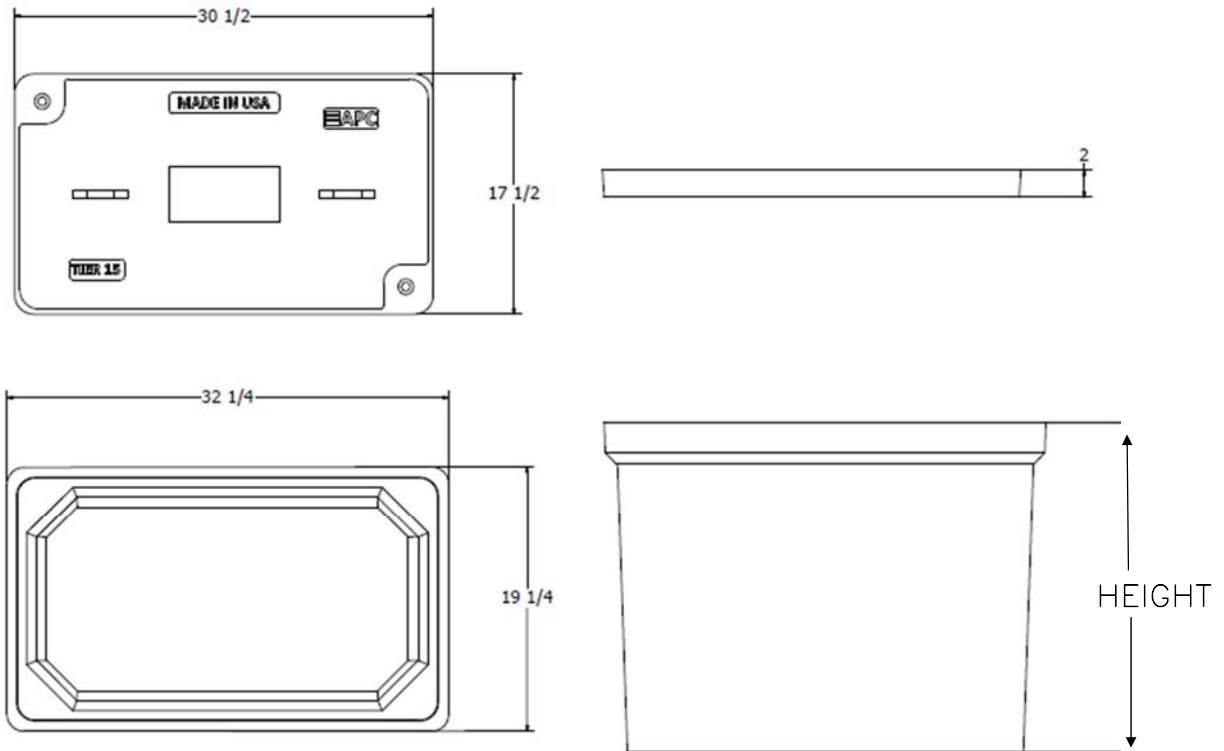

Components	Nominal Size	ANSI Tier	Part Number	Estimated Weight
Replacement Box	17"x30"x12"	Tier 22	P173012B22	66 lbs.
Replacement Box	17"x30"x18"	Tier 22	P173018B22	100 lbs.
Replacement Box	17"x30"x24"	Tier 22	P173024B22	120 lbs.
Replacement Box	17"x30"x30"	Tier 22	P173030B22	145 lbs.
Replacement Lids - T15	17"x30"	Tier 15	Various	72 lbs.
Replacement Lids - T22	17"x30"	Tier 22	Various	81 lbs.

Bolt options



Machine Thread



Auger Thread



33"x60" PC UNIT, 2PC TIER 15/22
36" HEIGHT



AMERICAN POLYMER COMPANY

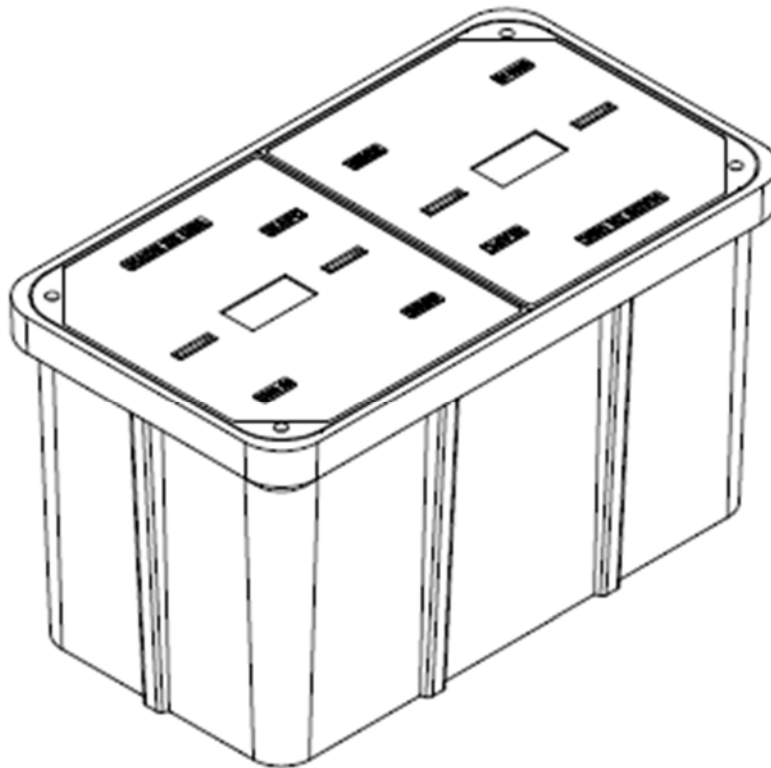

Description	Nominal Size	ANSI Tier	Part Number	Estimated Weight
PC Unit - TIER 15	33"x60"x36"	Tier 15	P336036U15...	930 lbs.
PC Unit - TIER 22	33"x60"x36"	Tier 22	P336036U22...	1030 lbs.



33"x60" PC UNIT, 2PC TIER 15/22

36" HEIGHT



AMERICAN POLYMER COMPANY

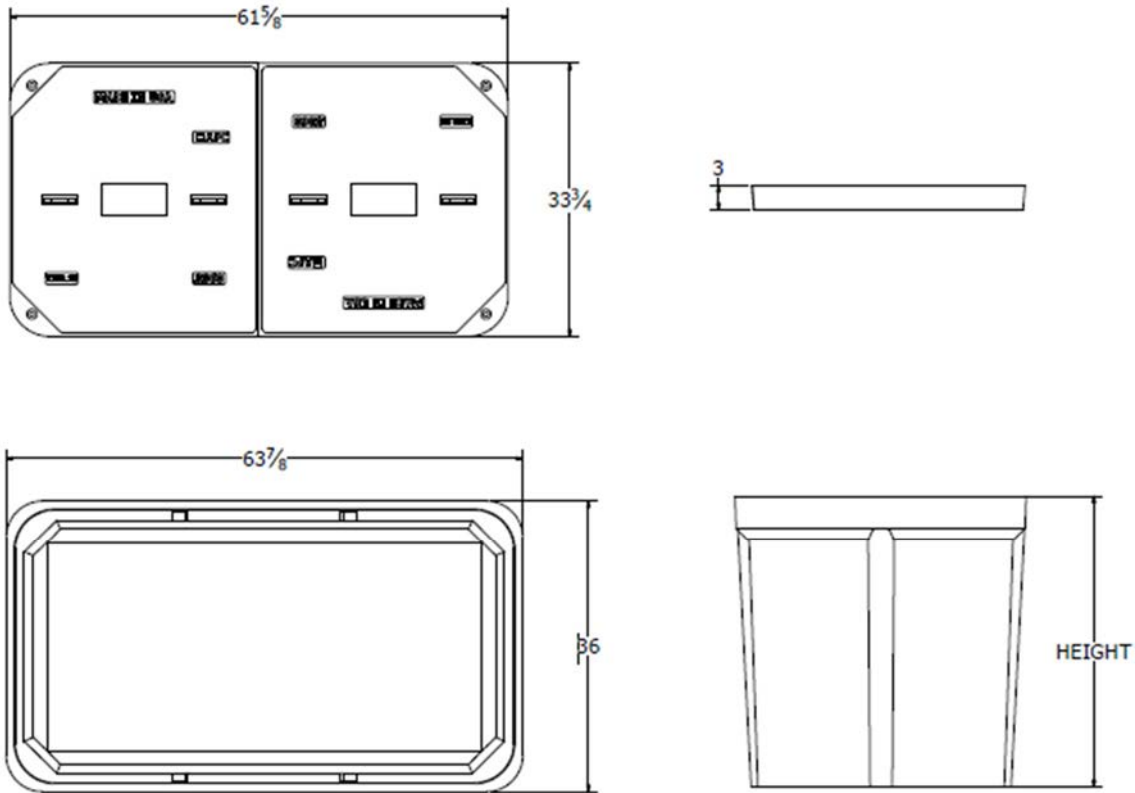

Components	Nominal Size	ANSI Tier	Part Number	Estimated Weight
Replacement Box	33"x60"x36"	Tier 22	P336036B22	530 lbs.
Replacement Lids - T15	33"x60" (half)	Tier 15	Various	200 lbs.
Replacement Lids - T22	33"x60" (half)	Tier 22	Various	250 lbs.

Bolt options

Hex Head



Machine Thread



Penta Head



Auger Thread



Spacing Charts Based on MUTCD		Must be Approved by an Engineer					
Speed (MPH) Prior To Road Work	SIGN SPACING, FT.		BUFFER SPACE, FT.	TAPER LENGTH, FT.	CHANNELIZING SPACING, FT.		
	Non-Divided Highways	Divided Highways	Length	Shoulder (10 ft. Width)	Lane (12 ft. Width)	Through Taper	Through Buffer/Work Area
0-35	200	200	250	70	245	35	50
40-45	350	500	360	150	540	40	80
50-55	500	1000	495	185	660	50	100
60-70	SA-1000, SB-1500, SC-2640		730	235	840	60	120
Urban Low Speed - 100 FT							

APPROVED/ACCEPTED BY:
ENGINEER, OWNER, or PRIME CONTRACTOR
 Check for Notice to Proceed.
BLC01a-F12_S College Mall Rd TCP1

Signature: _____

Company: _____

Road Runner Safety Services, Inc.

Date: 10/20/2022 Project: BLC01a-F12_S College Mall Rd TCP :
: Traffic Control Suggestion For: AEG :
By: Road Runner Safety Services, Inc. : Nathan

Comments:
Drawing not to scale. Traffic control plan must be approved by an engineer. This is a suggestion only. Road Runners Safety Services, Inc. has no liability for this suggested traffic control plan. Actual placement and spacing of all traffic control devices will depend on field conditions and must conform to MUTCD standards.

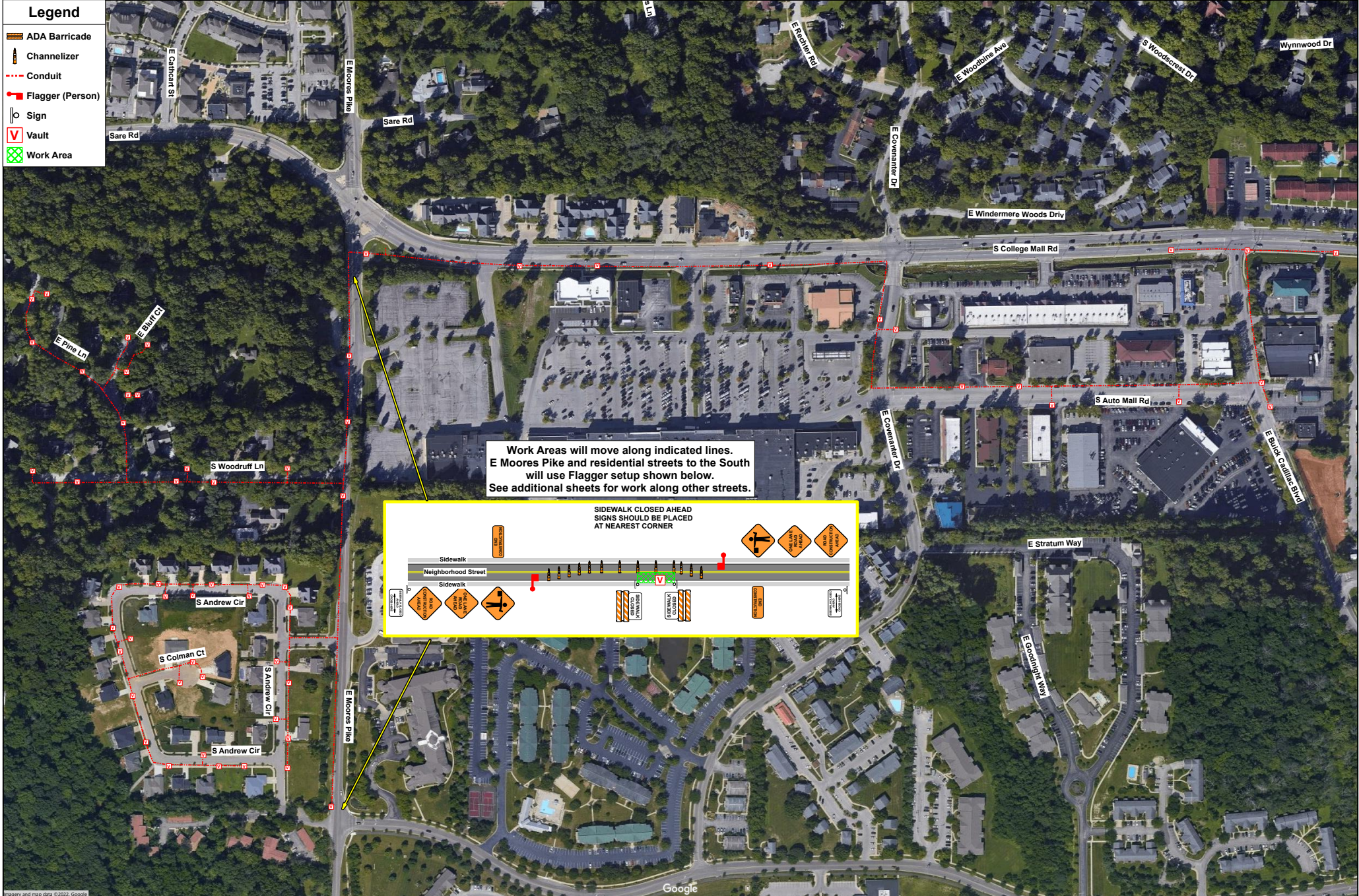

Spacing Charts Based on MUTCD Must be Approved by an Engineer

Speed (MPH) Prior To Road Work	SIGN SPACING, FT.		BUFFER SPACE, FT.	TAPER LENGTH, FT.		CHANNELIZING SPACING, FT.	
	Non-Divided Highways	Divided Highways	Length	Shoulder (10 ft Width)	Lane (12 ft Width)	Through Taper	Through Buffer/Work Area
0-35	200	200	250	70	245	35	50
40-45	350	500	360	150	540	40	80
50-55	500	1000	495	185	660	50	100
60-70	SA-1000, SB-1500, SC-2640 Urban Low Speed - 100 FT		730	235	840	60	120

APPROVED/ACCEPTED BY:
ENGINEER, OWNER, or PRIME CONTRACTOR
 Check for Notice to Proceed.
CO01 - 1603_Lafayette Ave TCP2

Signature: _____
Company: _____



Date: 10/20/2022 Project: BLC01a-F12_S College Mall Rd TCP2 :
: Traffic Control Suggestion For: AEG :
By: Road Runner Safety Services, Inc. : Nathan

Comments:
Drawing not to scale. Traffic control plan must be approved by an engineer. This is a suggestion only. Road Runners Safety Services, Inc. has no liability for this suggested traffic control plan. Actual placement and spacing of all traffic control devices will depend on field conditions and must conform to MUTCD standards.

Legend

- ADA Barricade
- Arrow Board
- Channelizer
- Sign
- Trimline
- Vault
- Work Area

Lane Closure setup to be used on S College Mall Rd

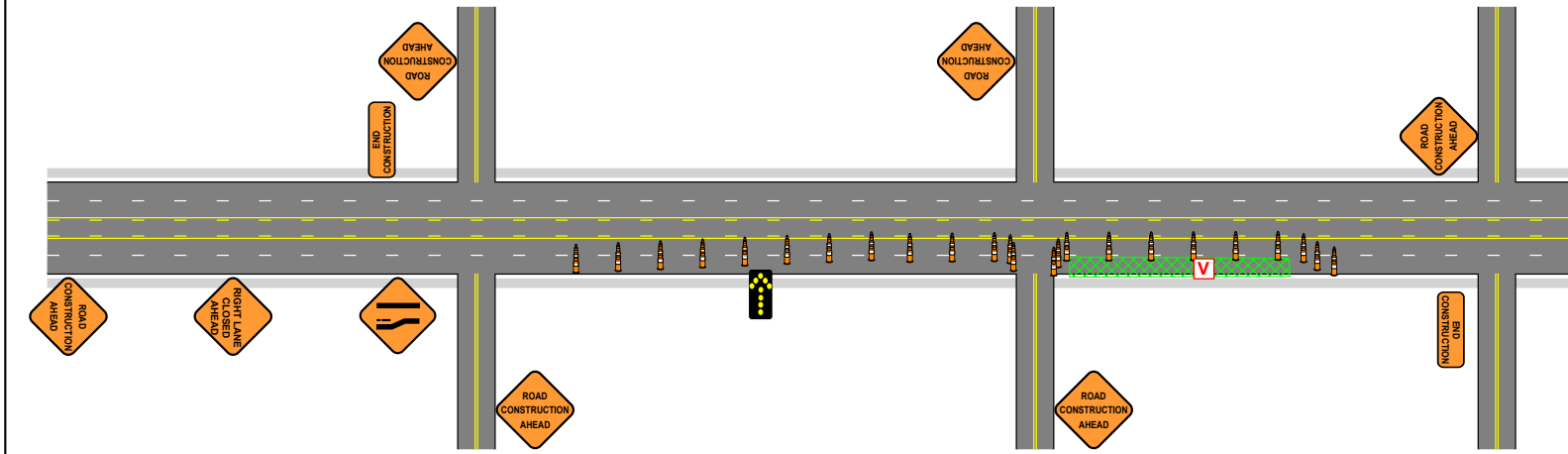

Road Construction Ahead signs to be placed on all side streets within work area. Sidewalk Closed Ahead Cross Here signs to be placed at nearest crossing.

Lane Shift to be used on S Auto Mall Rd

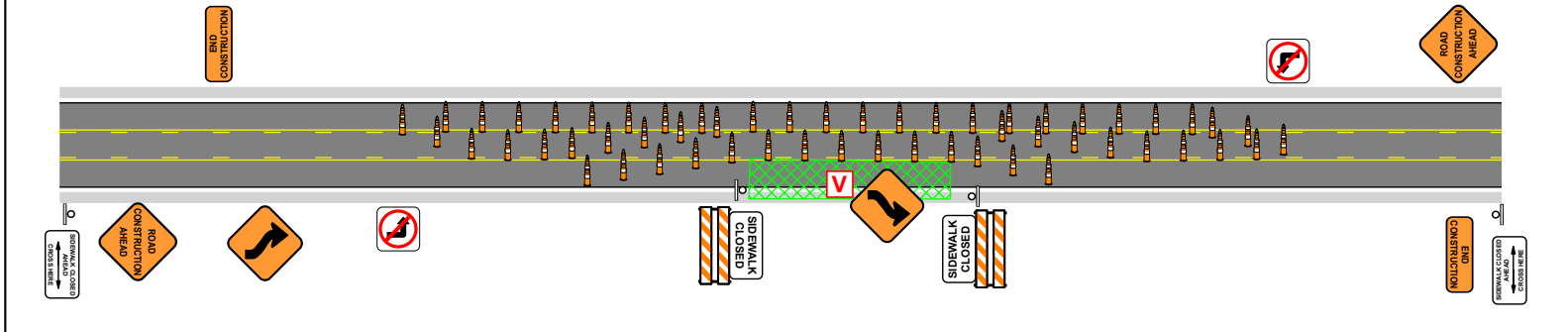

**Lane Shift to be used on E Covenant Dr and E Buick Cadillac Blvd
Maintain 10 ft driving lanes.**

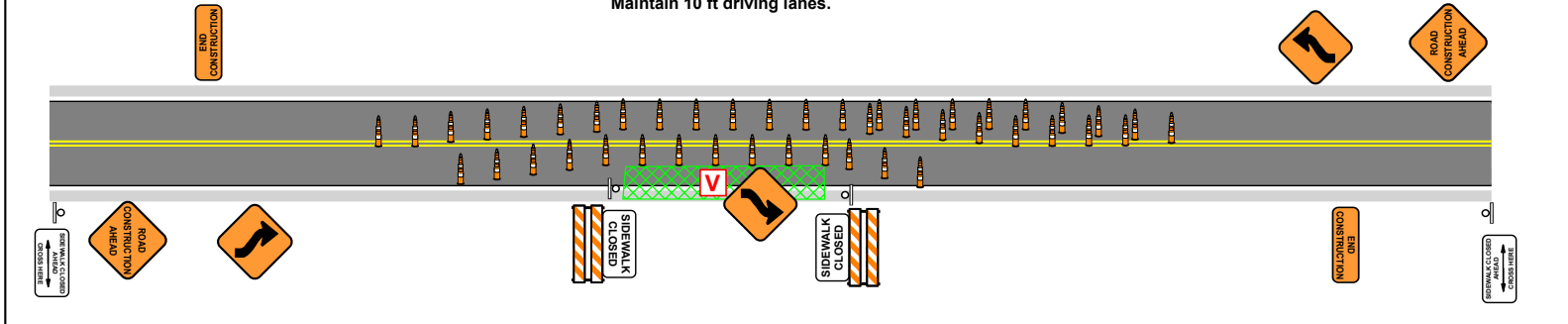

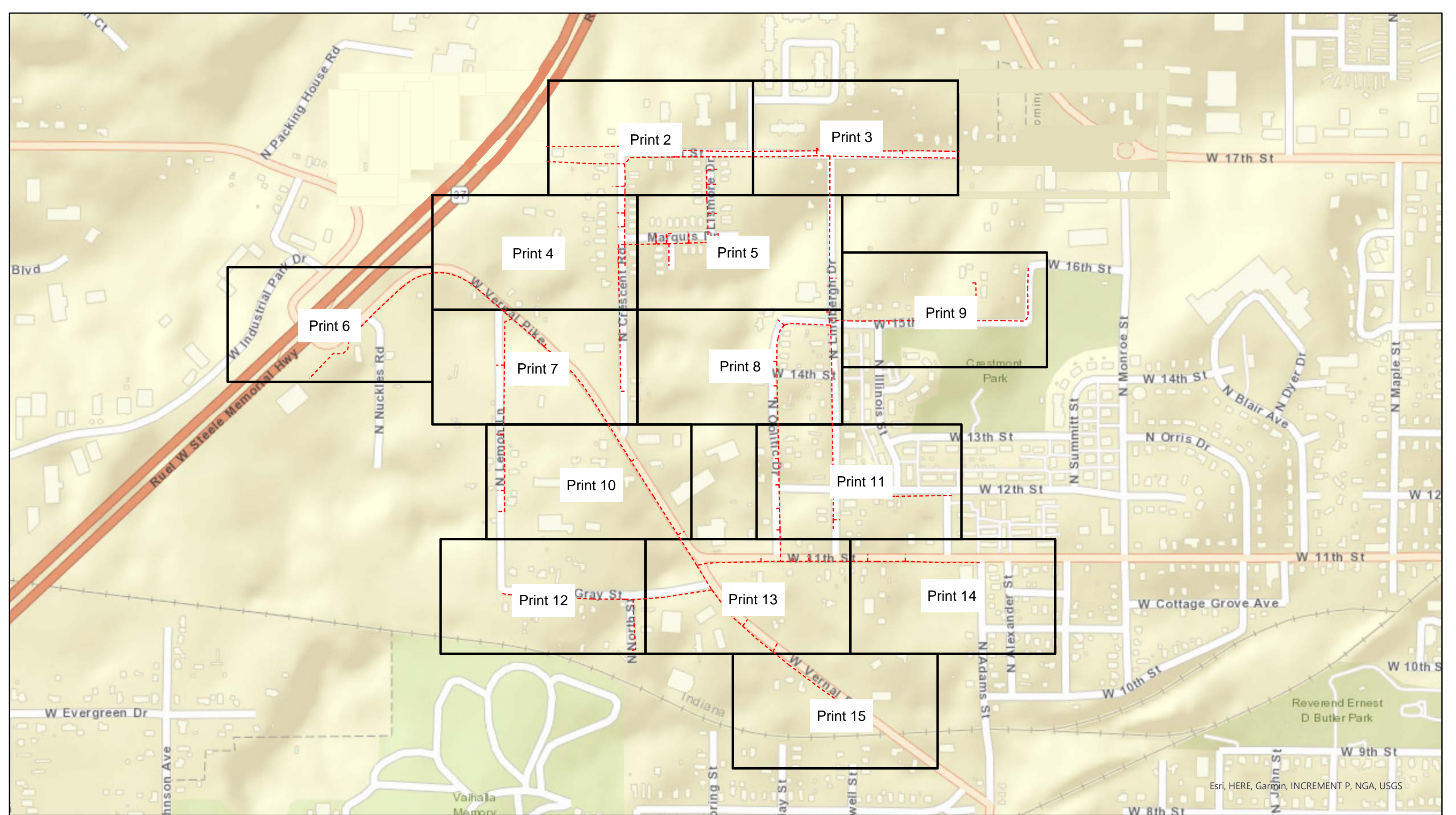

Esri, HERE, Garmin, INCREMENT P, NGA, USGS



Legend BLN01b-F13_N Crescent Rd

- Overhead Strand
- - - Conduit
- Grids



City of Bloomington, IN Permit:
Design View

INI	BY	DATE	DESCRIPTION

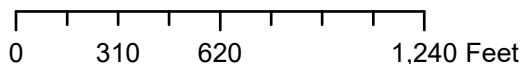

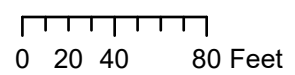
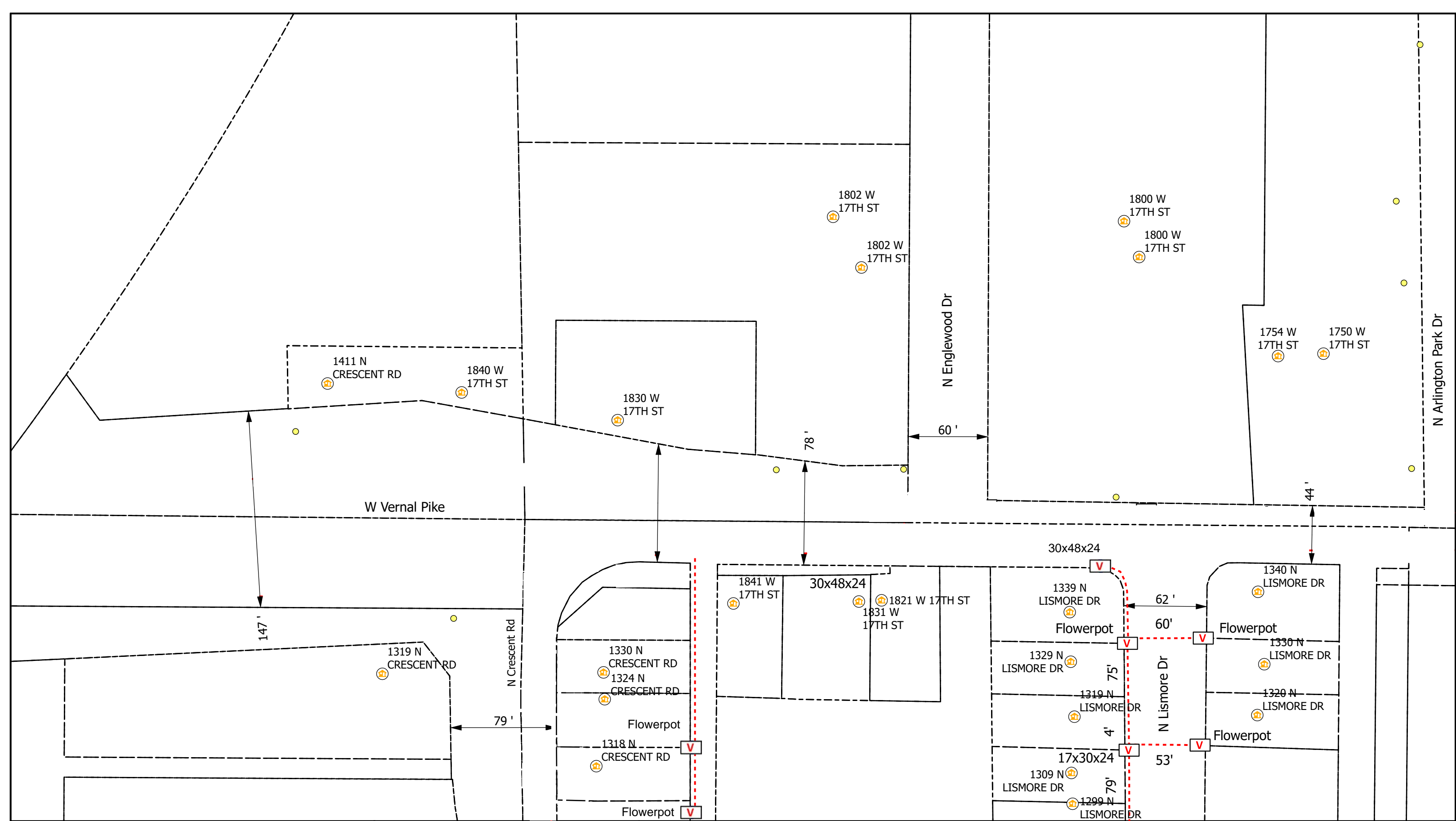

Legend

- Poles
- V Vaults
- Overhead Strand
- Conduit
- R Risers
- A Address
- Y Anchor
- └─ Sidewalk
- Bloomington_Parcels
- Grids

All Flowerpots 12" DIA



City of Bloomington, IN Permit:
Design View

INI	BY	DATE	DESCRIPTION



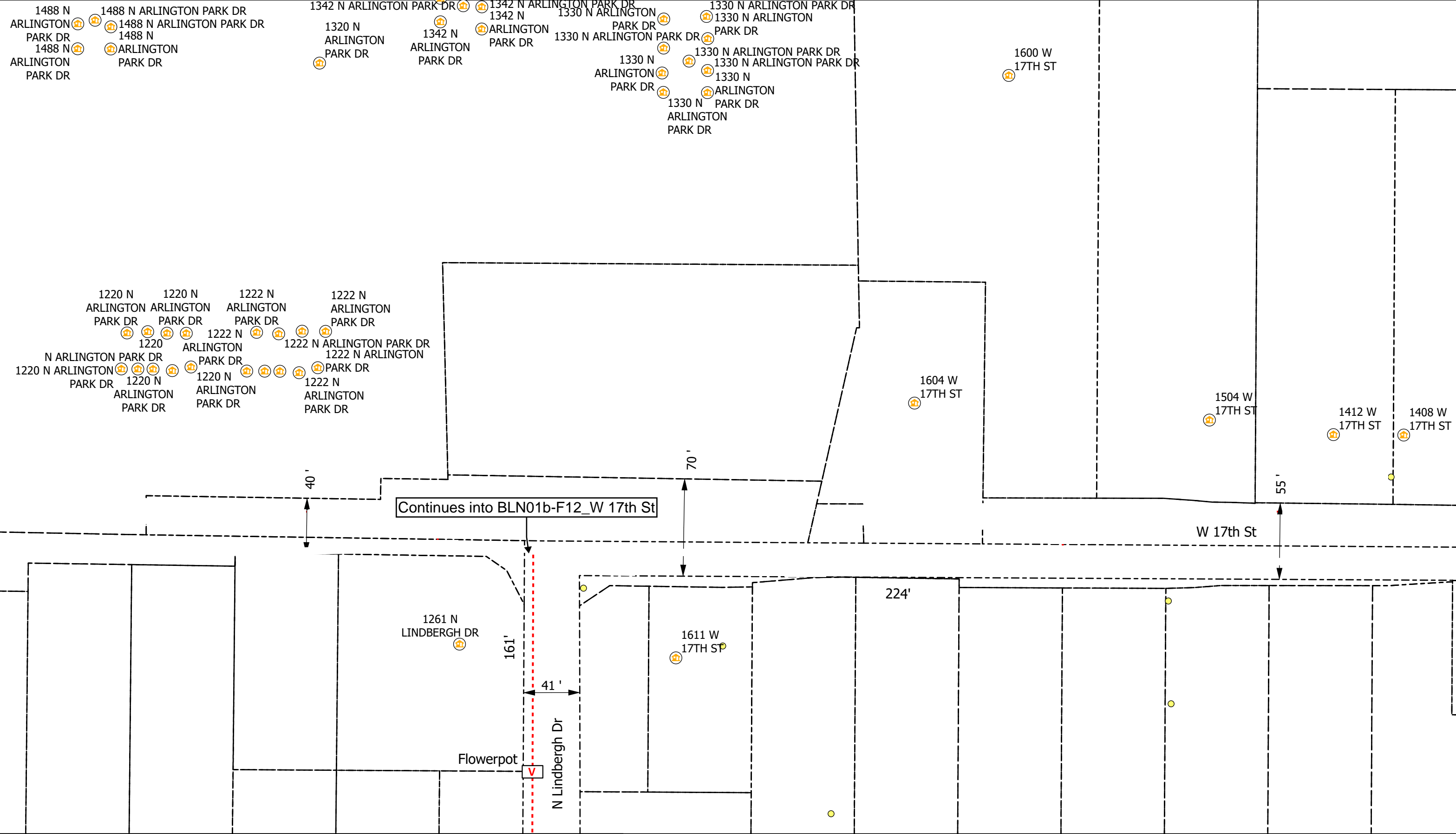

0 20 40 80 Feet

Legend

- Poles
- V Vaults
- Overhead Strand
- - - Conduit
- Ⓡ Risers
- Ⓜ Address
- Y Anchor
- ↖ Sidewalk
- Bloomington_Parcels
- Grids

All Flowerpots 12" DIA



City of Bloomington, IN Permit:
Design View

INI	BY	DATE	DESCRIPTION



Ruel W Steele Memorial Hwy

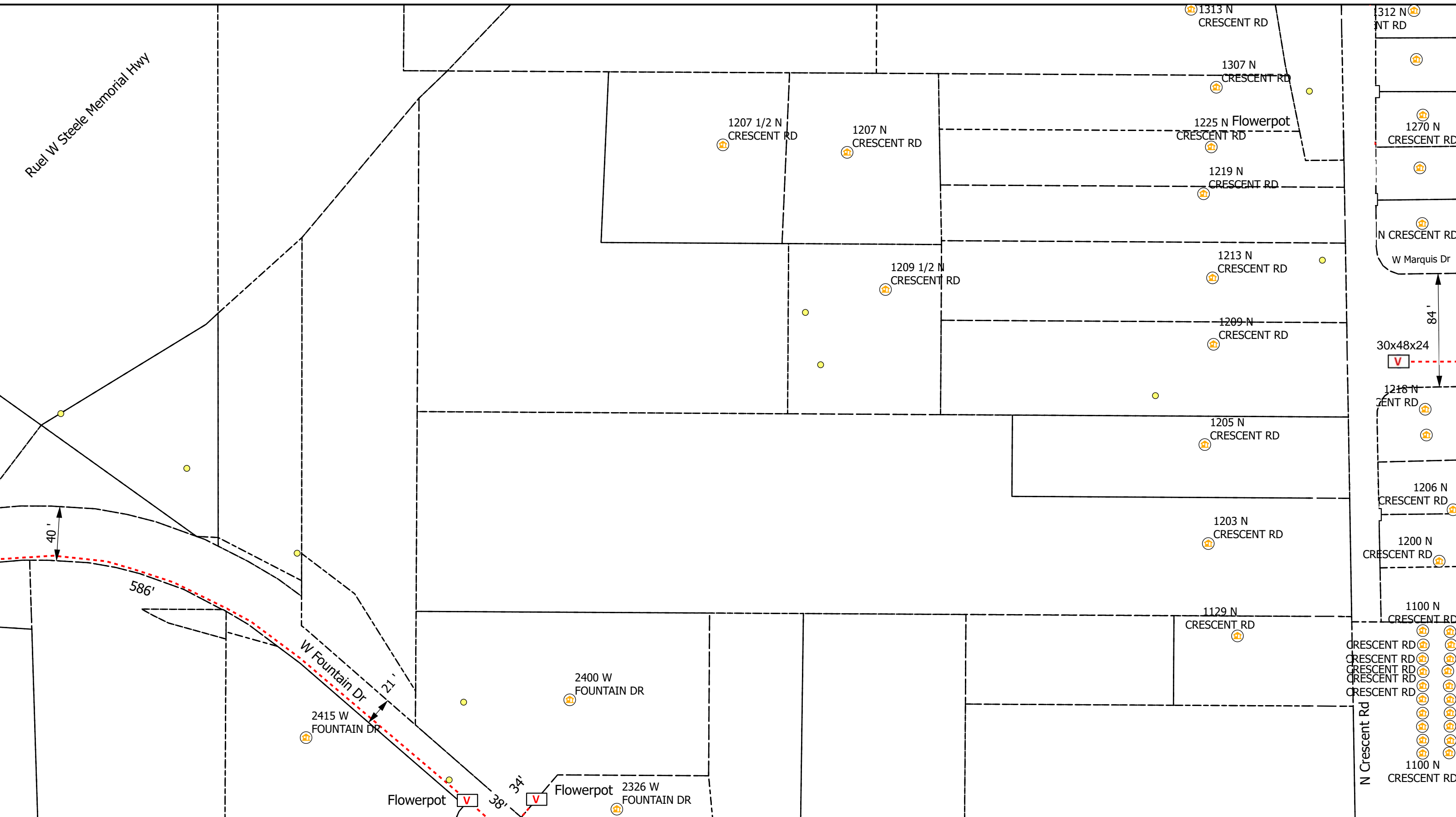

Legend

- Poles
- V Vaults
- Overhead Strand
- - - Conduit
- Ⓡ Risers
- Ⓜ Address
- Y Anchor
- ↖ Sidewalk
- Bloomington_Parcels
- Grids

All Flowerpots 12" DIA



City of Bloomington, IN Permit:
Design View

INI	BY	DATE	DESCRIPTION



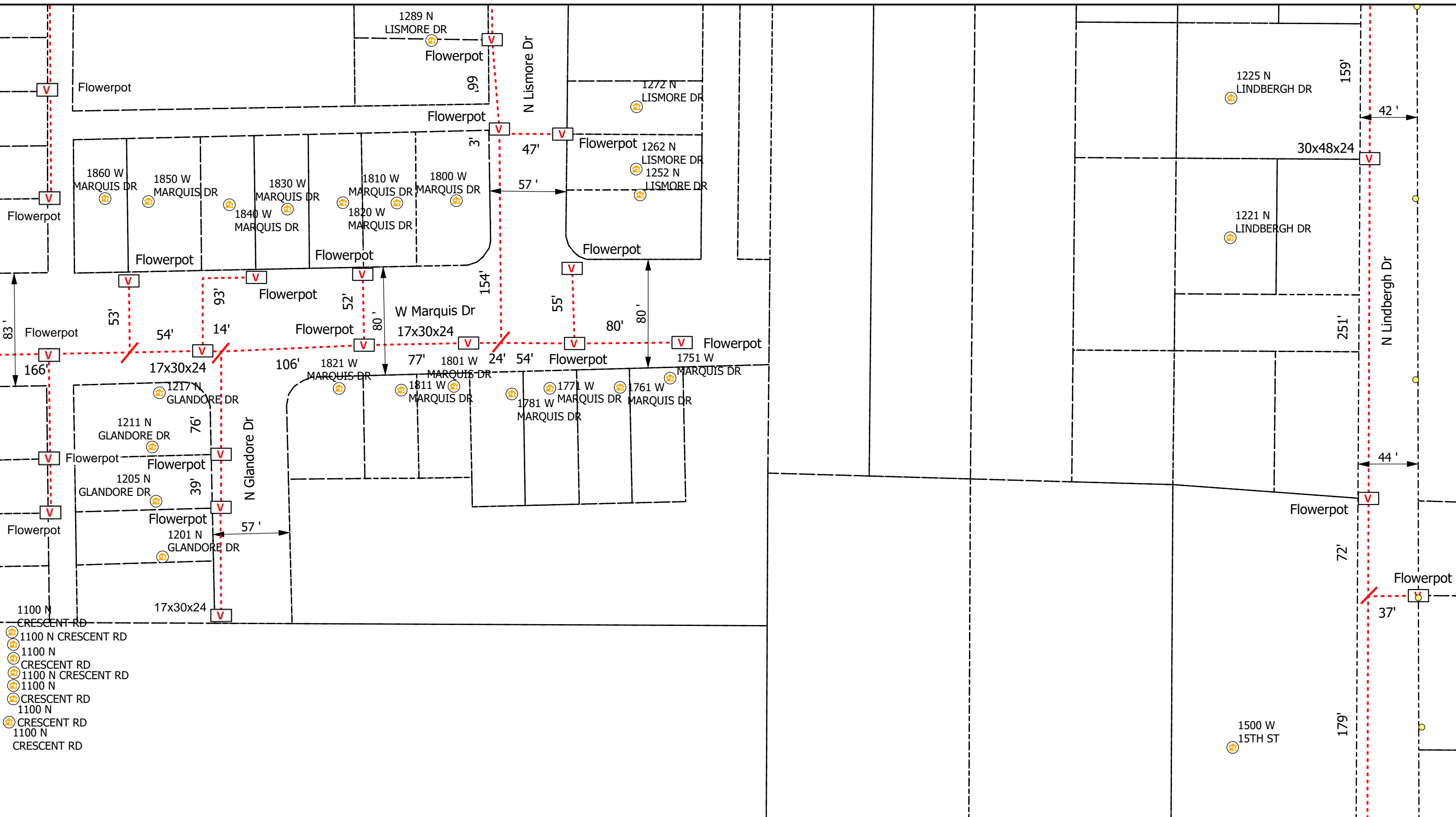

1100 N
 CRESCENT RD
 1100 N CRESCENT RD
 1100 N
 CRESCENT RD
 1100 N CRESCENT RD
 1100 N
 CRESCENT RD
 1100 N
 CRESCENT RD
 1100 N
 CRESCENT RD
 1100 N
 CRESCENT RD



Legend

- Poles
- V Vaults
- Overhead Strand
- Conduit
- Ⓢ Risers
- Ⓜ Address
- Y Anchor
- ↶ Sidewalk
- Bloomington_Parcels
- Grids

All Flowerpots 12" DIA



City of Bloomington, IN Permit:
Design View

INI	BY	DATE	DESCRIPTION



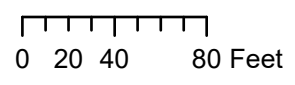
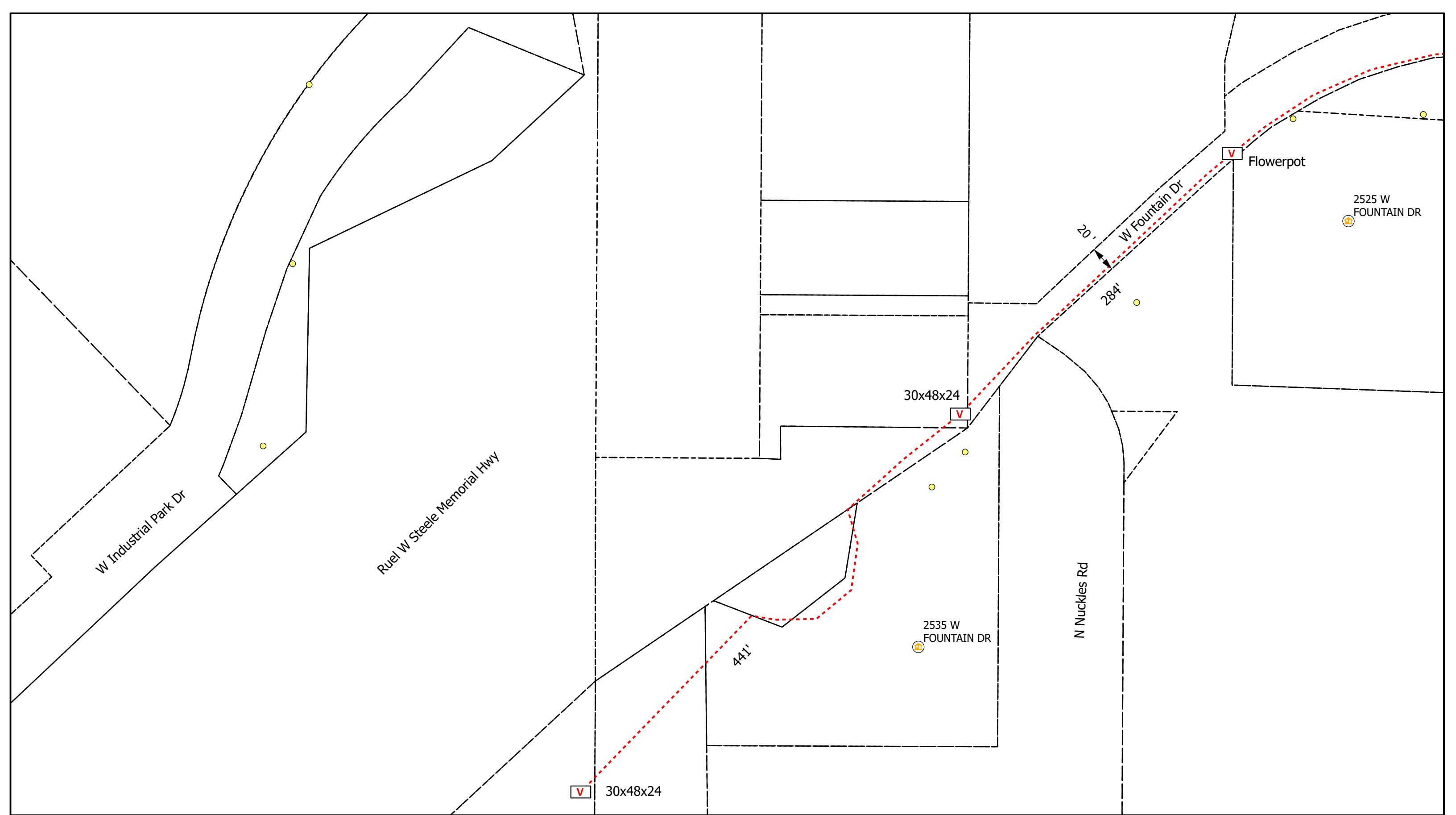

Legend

- Poles
- V Vaults
- Overhead Strand
- - - Conduit
- R Risers
- A Address
- Y Anchor
- └─┘ Sidewalk
- Bloomington_Parcels
- Grids

All Flowerpots 12" DIA



City of Bloomington, IN Permit:
Design View

INI	BY	DATE	DESCRIPTION



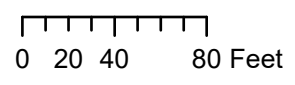
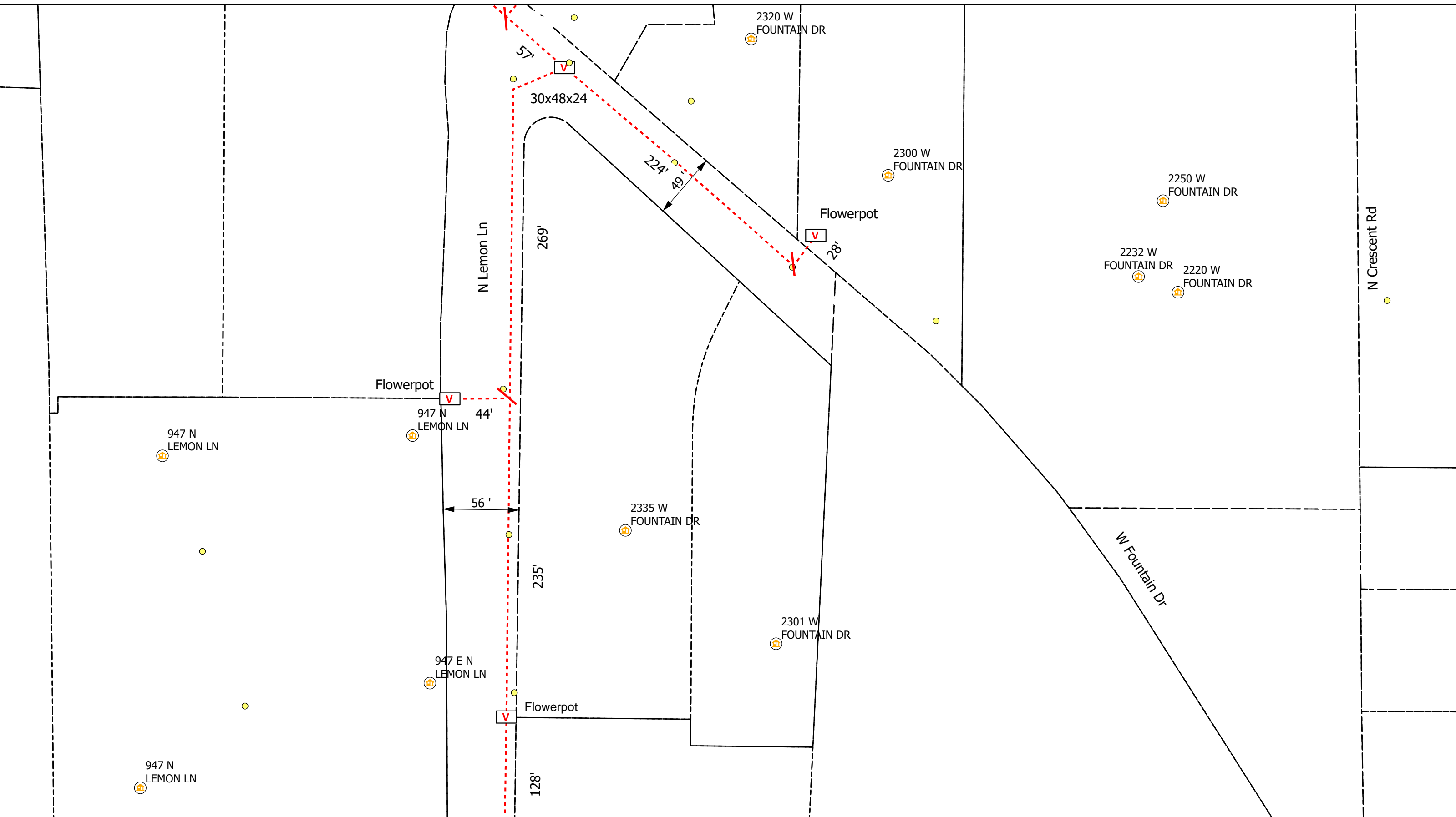

Legend

- Poles
- V Vaults
- Overhead Strand
- Conduit
- R Risers
- A Address
- Y Anchor
- └─┘ Sidewalk
- Bloomington_Parcels
- Grids

All Flowerpots 12" DIA



City of Bloomington, IN Permit:
Design View

INI	BY	DATE	DESCRIPTION



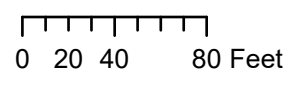
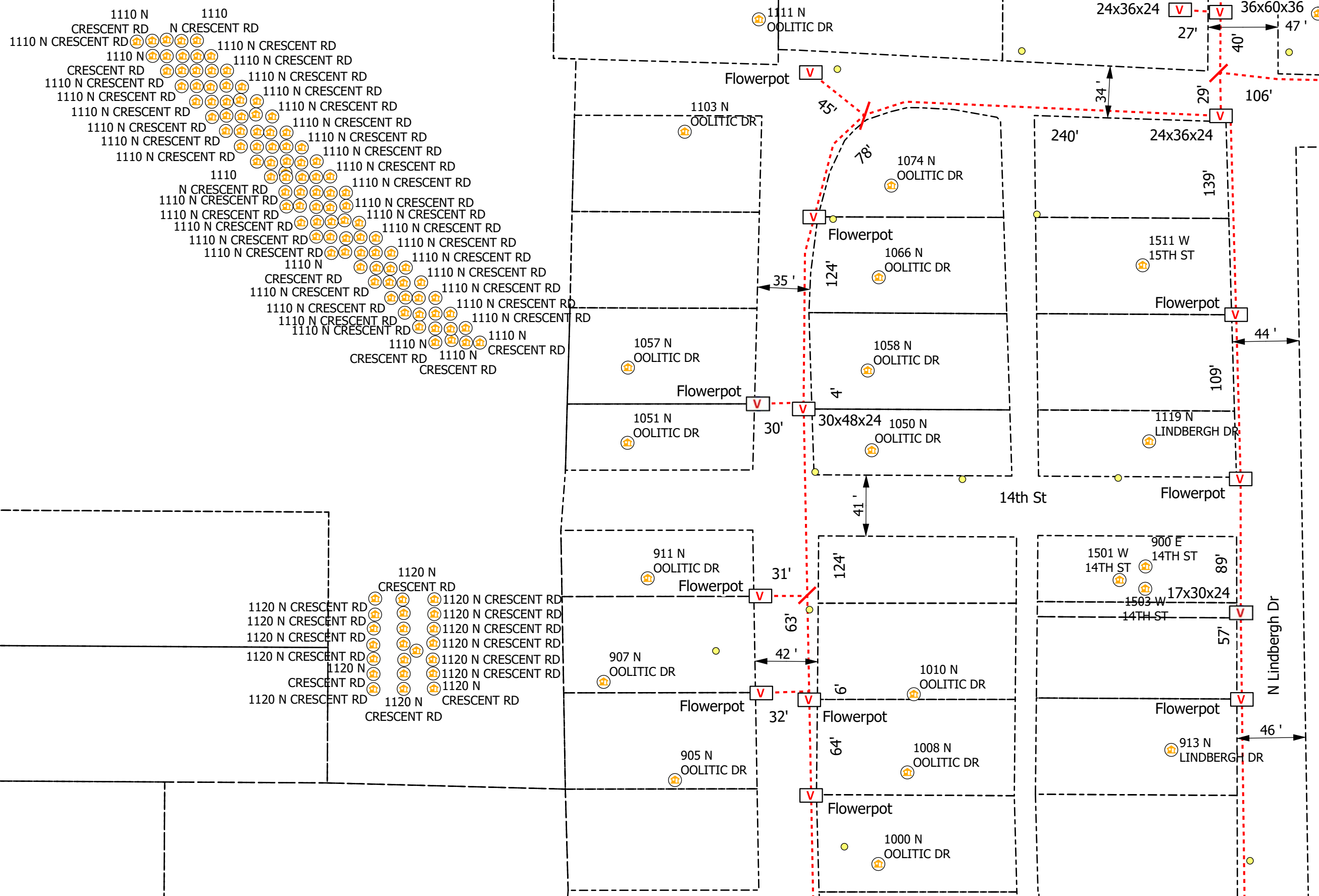

Legend

- Poles
- V Vaults
- Overhead Strand
- Conduit
- R Risers
- A Address
- Y Anchor
- └─ Sidewalk
- Bloomington_Parcels
- Grids

All Flowerpots 12" DIA



City of Bloomington, IN Permit:
Design View

INI	BY	DATE	DESCRIPTION



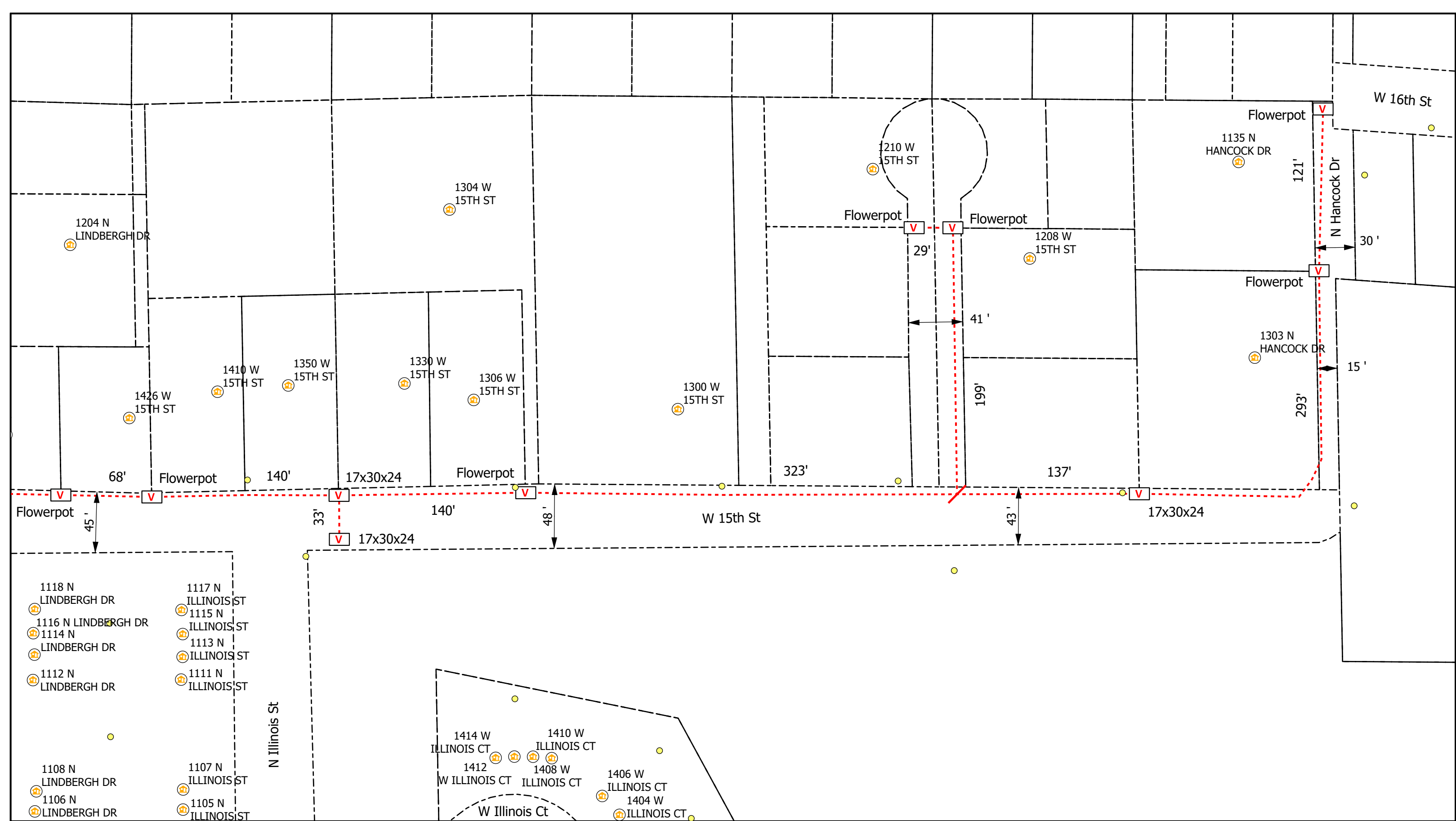

Legend

- Poles
- ⊕ Risers
- ⌞ Sidewalk
- V Vaults
- Ⓜ Address
- Bloomington_Parcels
- Overhead Strand
- Conduit
- Y Anchor
- Grids

All Flowerpots 12" DIA



City of Bloomington, IN Permit:
Design View

INI	BY	DATE	DESCRIPTION



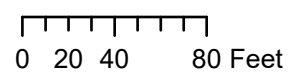
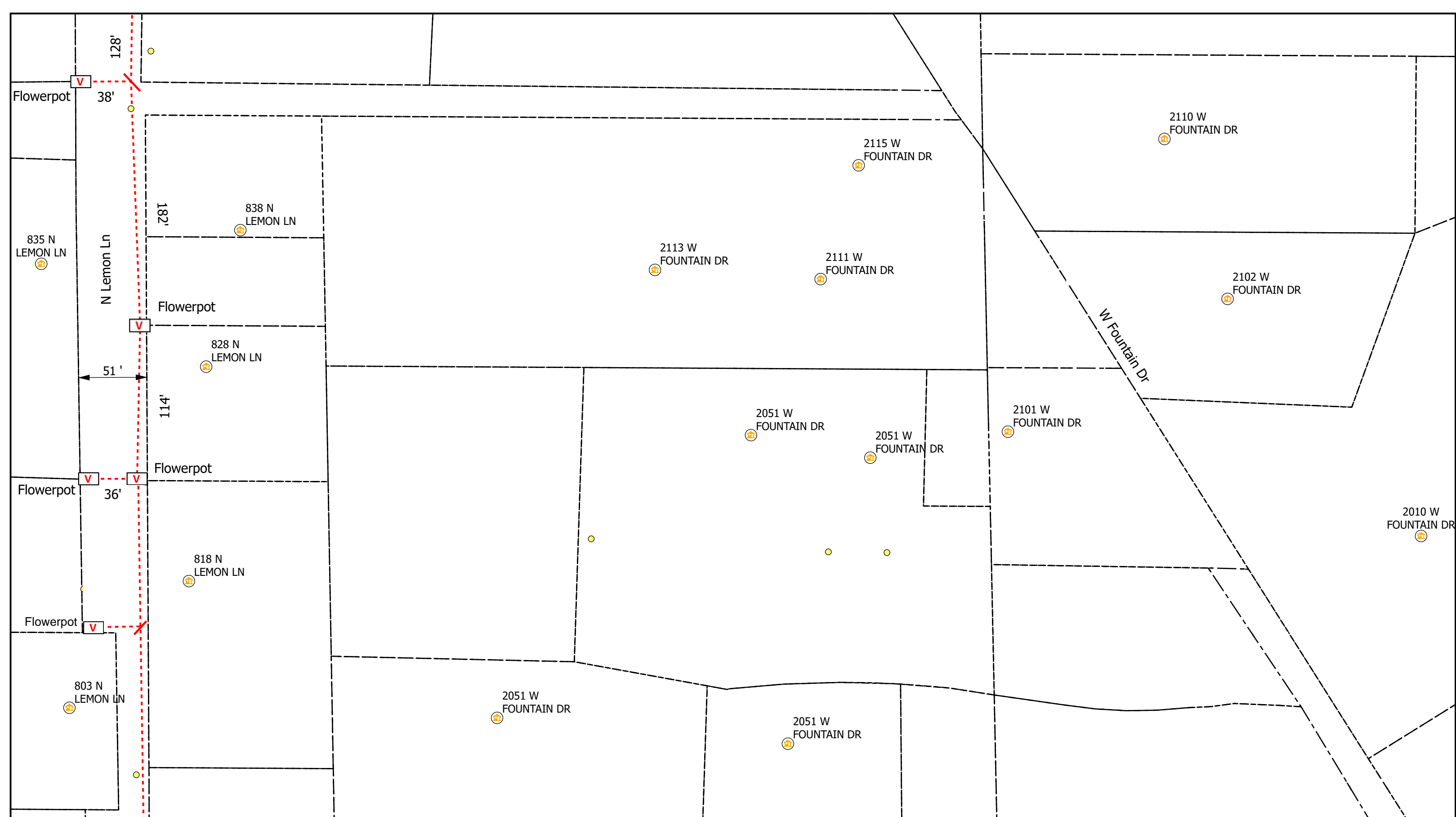

Legend

- Poles
- Ⓡ Risers
- ↖ Sidewalk
- V Vaults
- 🏠 Address
- Bloomington_Parcels
- Overhead Strand
- Y Anchor
- - - Conduit
- Grids

All Flowerpots 12" DIA



City of Bloomington, IN Permit:
Design View

INI	BY	DATE	DESCRIPTION



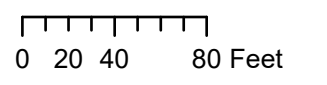
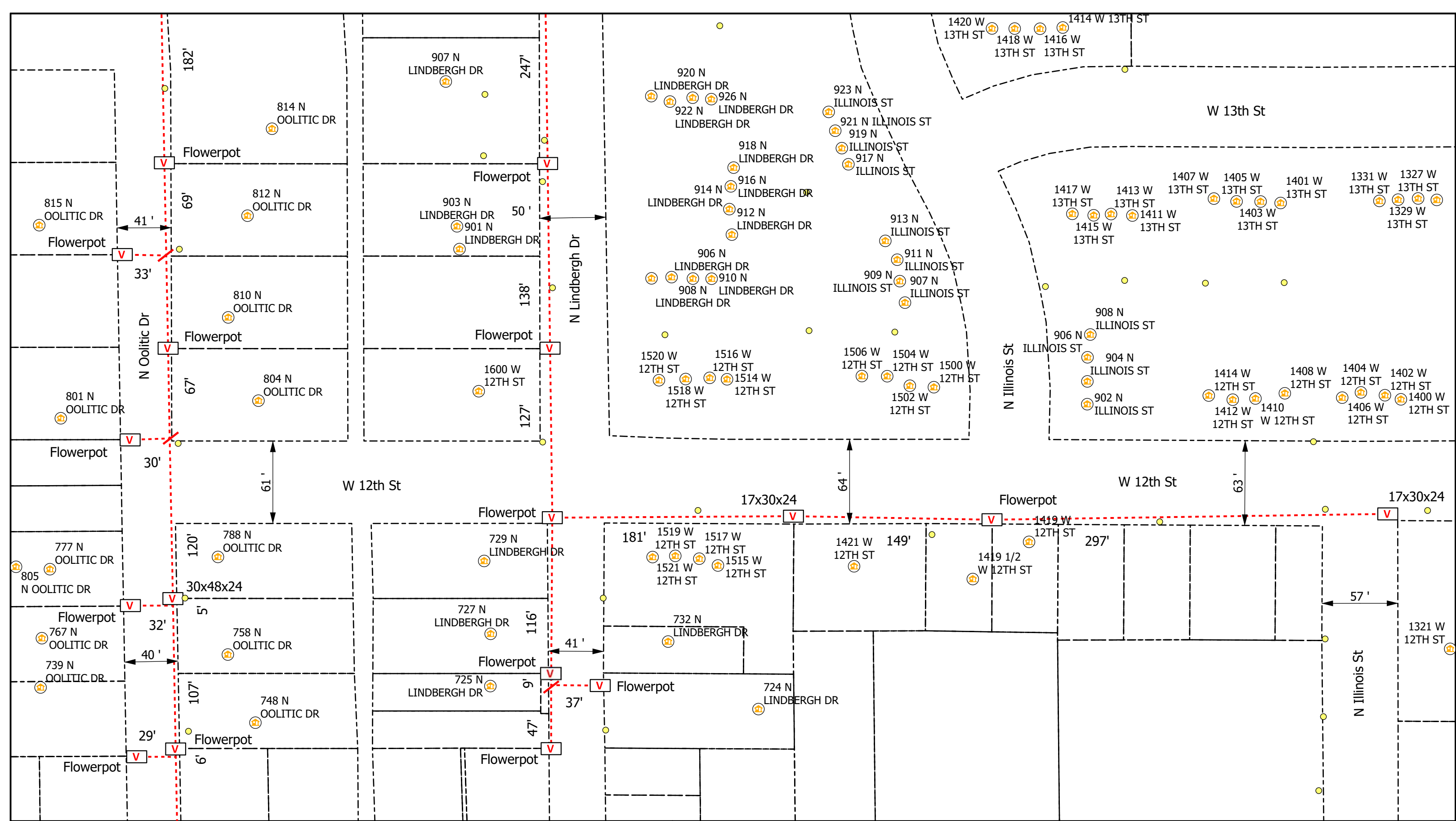

Legend

- Poles
- Risers
- ⬆ Sidewalk
- V Vaults
- 🏠 Address
- Bloomington_Parcels
- Overhead Strand
- Y Anchor
- Grids
- Conduit

All Flowerpots 12" DIA



City of Bloomington, IN Permit:
Design View











INI	BY	DATE	DESCRIPTION





0 20 40 80 Feet

Legend

-  Poles
-  Risers
-  Sidewalk
-  Vaults
-  Address
-  Anchor
-  Overhead Strand
-  Conduit
-  Bloomington_Parcels
-  Grids

All Flowerpots 12" DIA

N



City of Bloomington, IN Permit:
Design View

INI	BY	DATE	DESCRIPTION

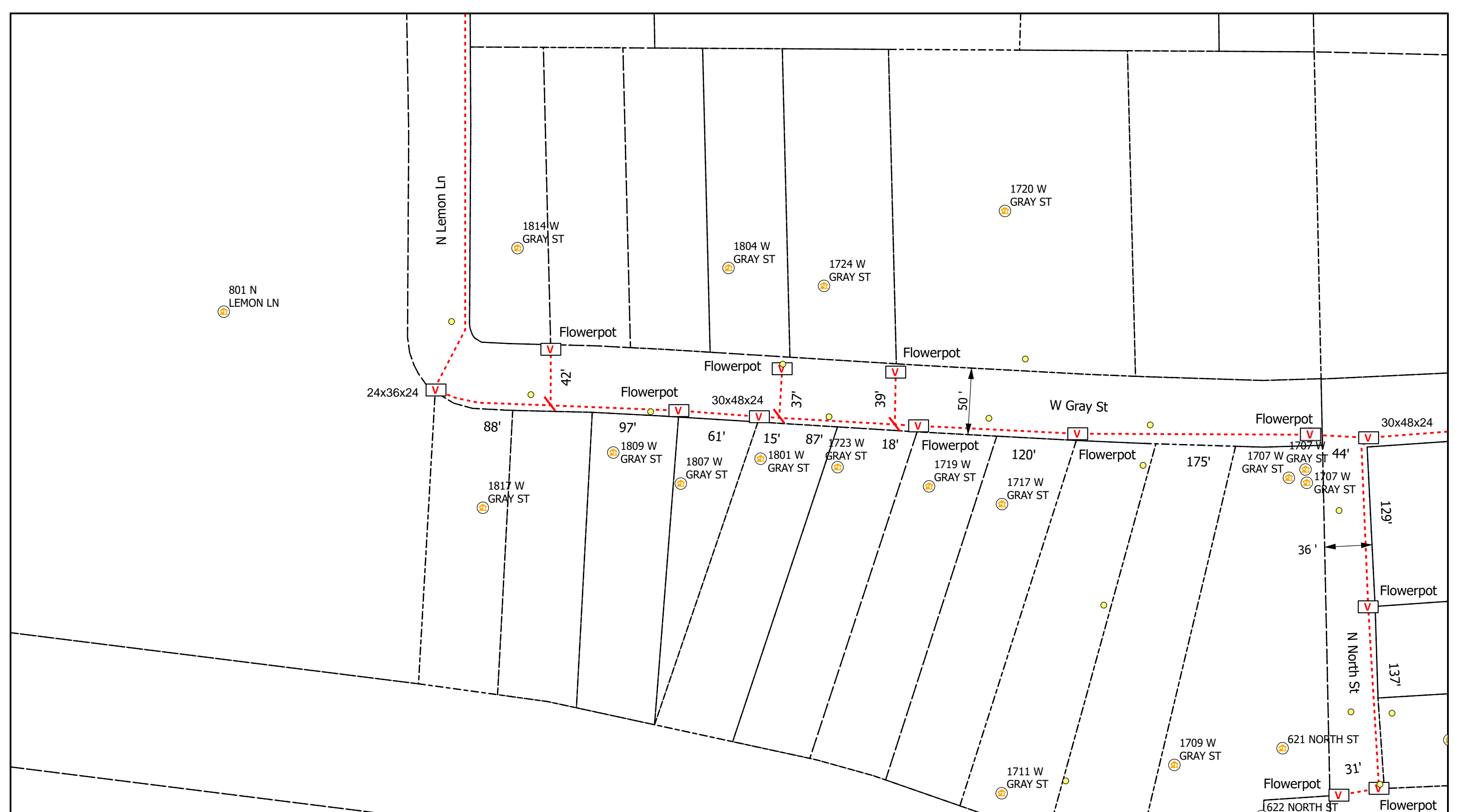

Vault might be in the dig path for some drainage work. Wait for coordination with crew completing the path extension project.

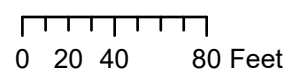
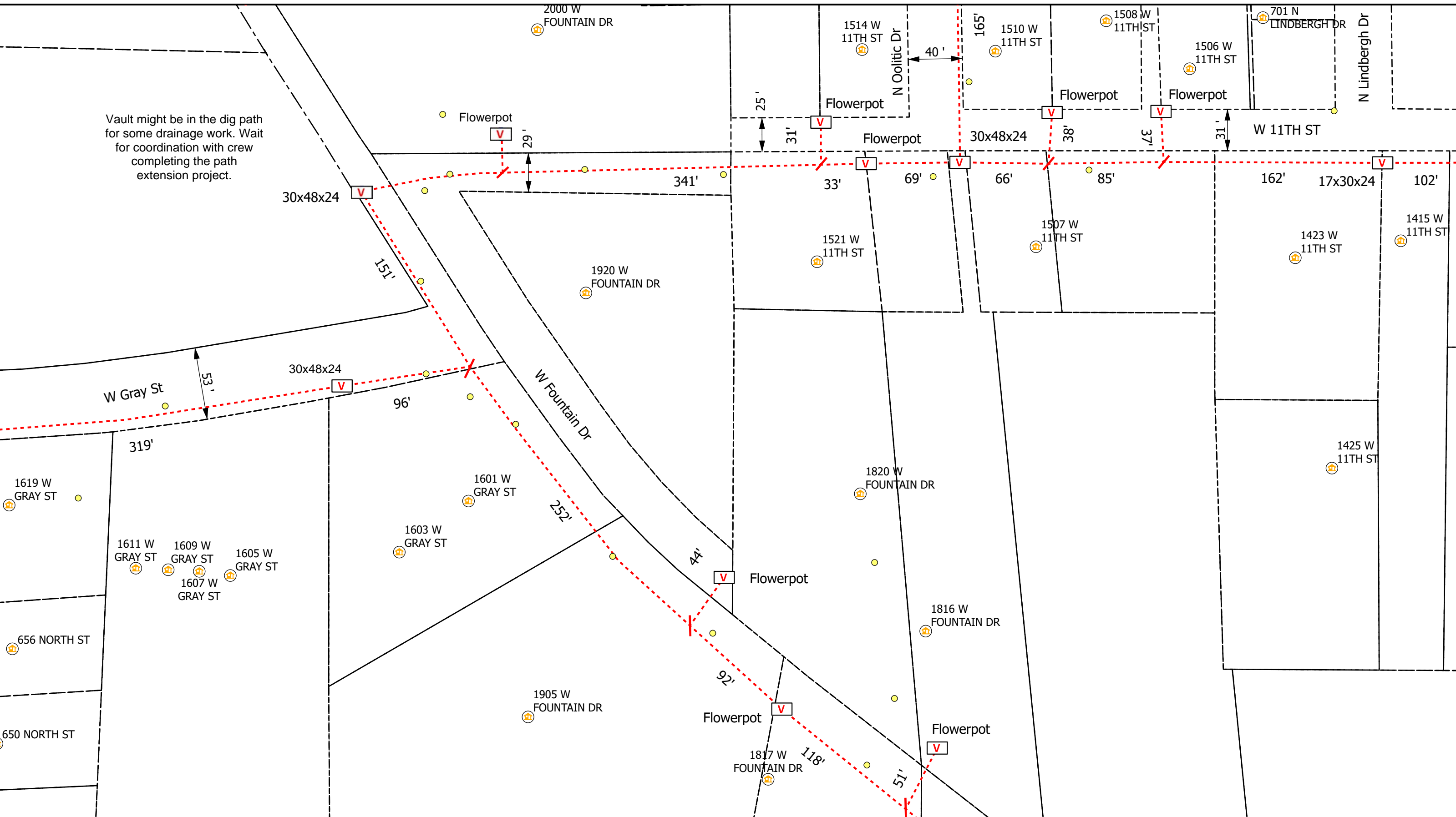

Legend

- Poles
- V Vaults
- Overhead Strand
- - - Conduit
- R Risers
- A Address
- Y Anchor
- ↖ Sidewalk
- Bloomington_Parcels
- Grids

All Flowerpots 12" DIA



City of Bloomington, IN Permit:
Design View

INI	BY	DATE	DESCRIPTION



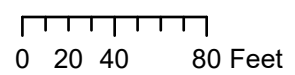
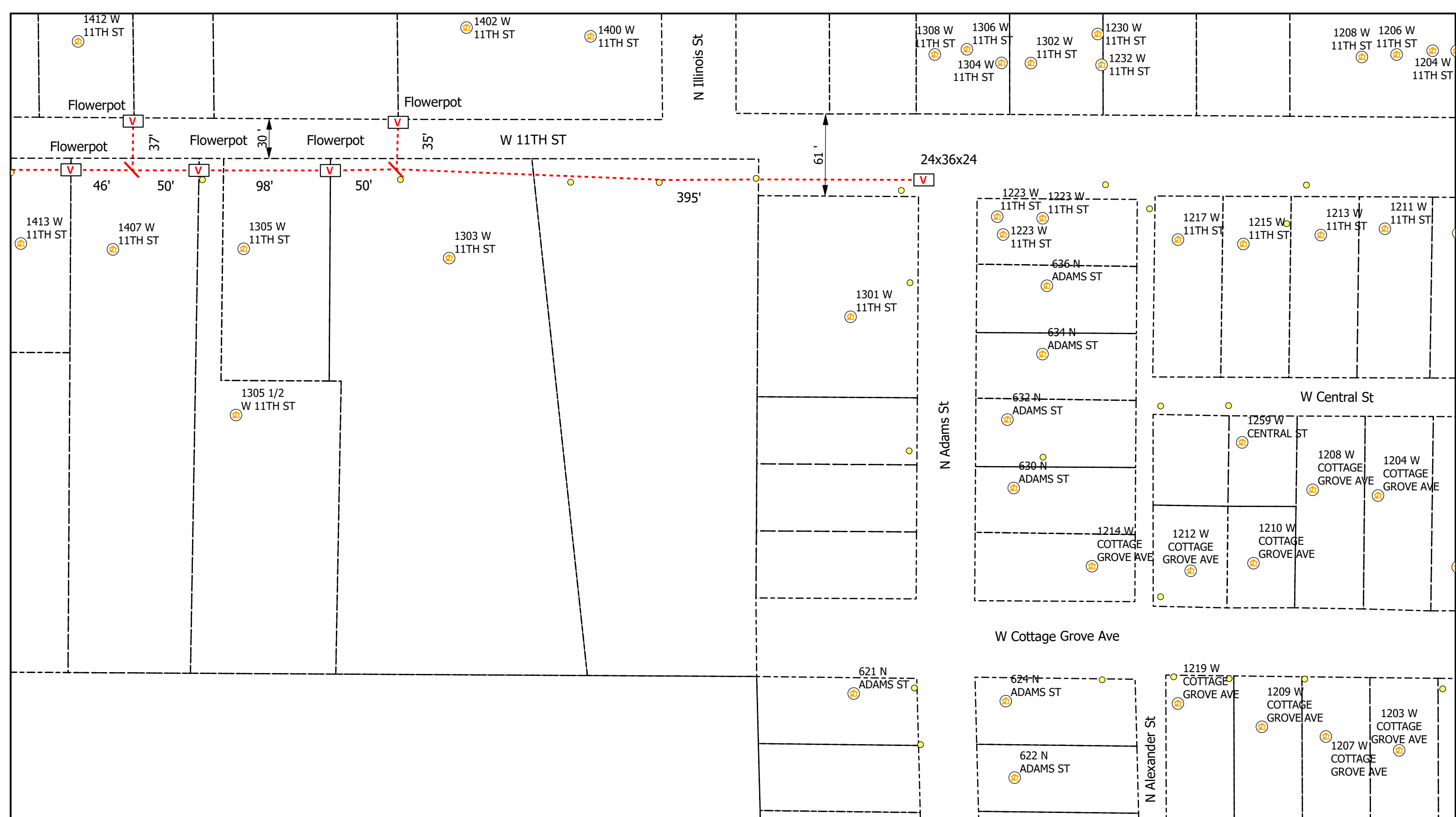

Legend

- Poles
- Ⓡ Risers
- Ⓜ Vaults
- Overhead Strand
- - - Conduit
- 🏠 Address
- Y Anchor
- ↖ Sidewalk
- Bloomington_Parcels
- Grids

All Flowerpots 12" DIA



City of Bloomington, IN Permit:
Design View

INI	BY	DATE	DESCRIPTION



1600 W FOUNTAIN DR

17x30x24

1803 W FOUNTAIN DR

444'

46'

Flowerpot

W Fountain Dr

Vault might be in the dig path for some drainage work. Wait for coordination with crew completing the path extension project.

1634 W 8TH ST
1630 W 8TH ST

425 N HAY ST

428 N HAY ST

424 N HAY ST

420 N HAY ST

429 N HOPEWELL ST

430 N HOPEWELL ST

420 N HOPEWELL ST

1313 W FOUNTAIN DR

1309 W FOUNTAIN DR

N Hay St

N Hopewell St

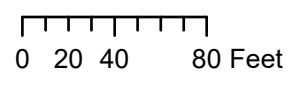

Legend

- Poles
- Vaults
- Overhead Strand
- Conduit
- Risers
- Address
- Anchor
- Sidewalk
- Bloomington_Parcels
- Grids

All Flowerpots 12" DIA



City of Bloomington, IN Permit:
Design View

INI	BY	DATE	DESCRIPTION



CONCEPTUAL SIDE VIEW

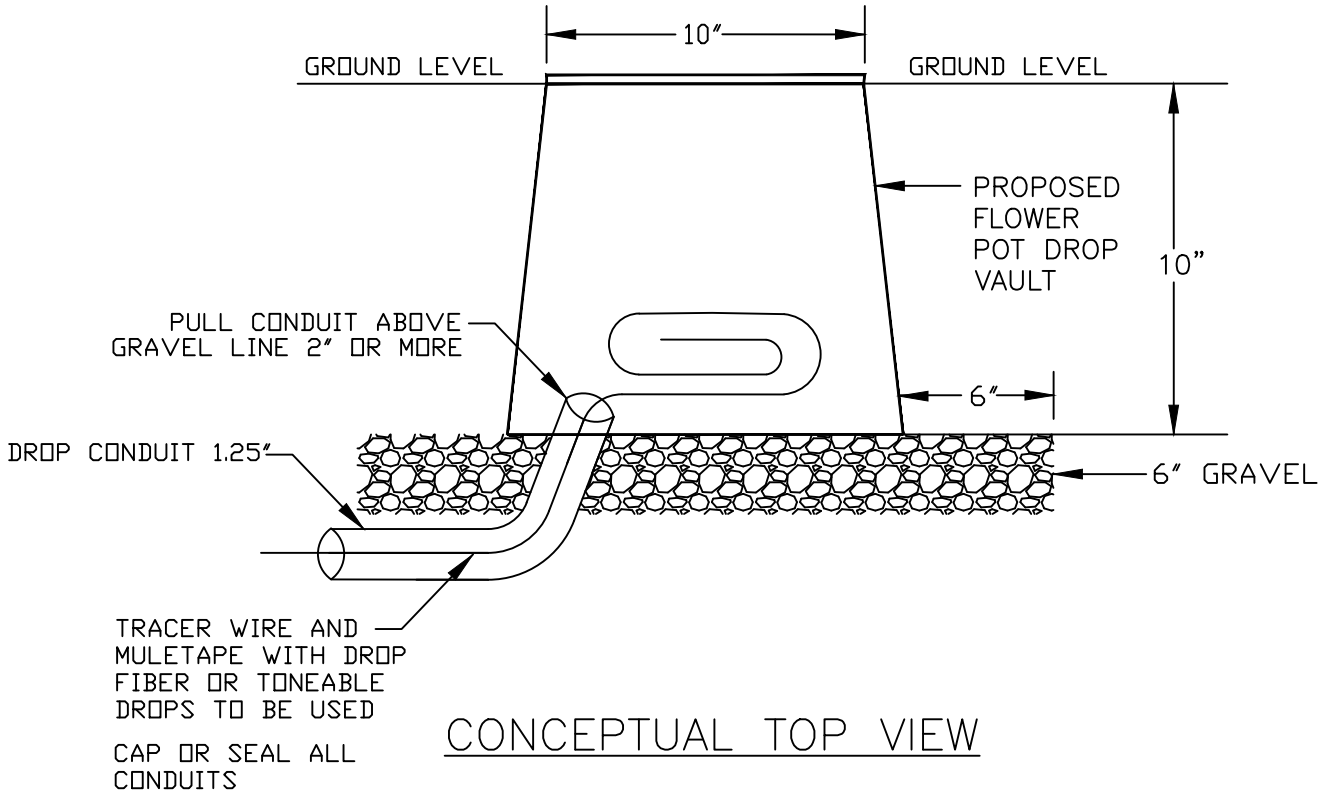

CONCEPTUAL TOP VIEW

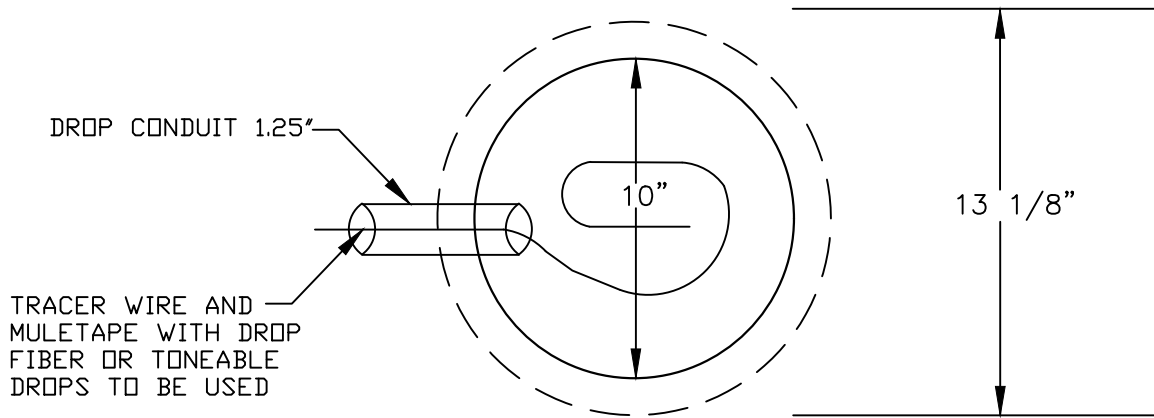

FLOWER POT

30"x48" PC UNIT, 2PC TIER 15/22
 18", 24", and 36" HEIGHT



AMERICAN POLYMER COMPANY

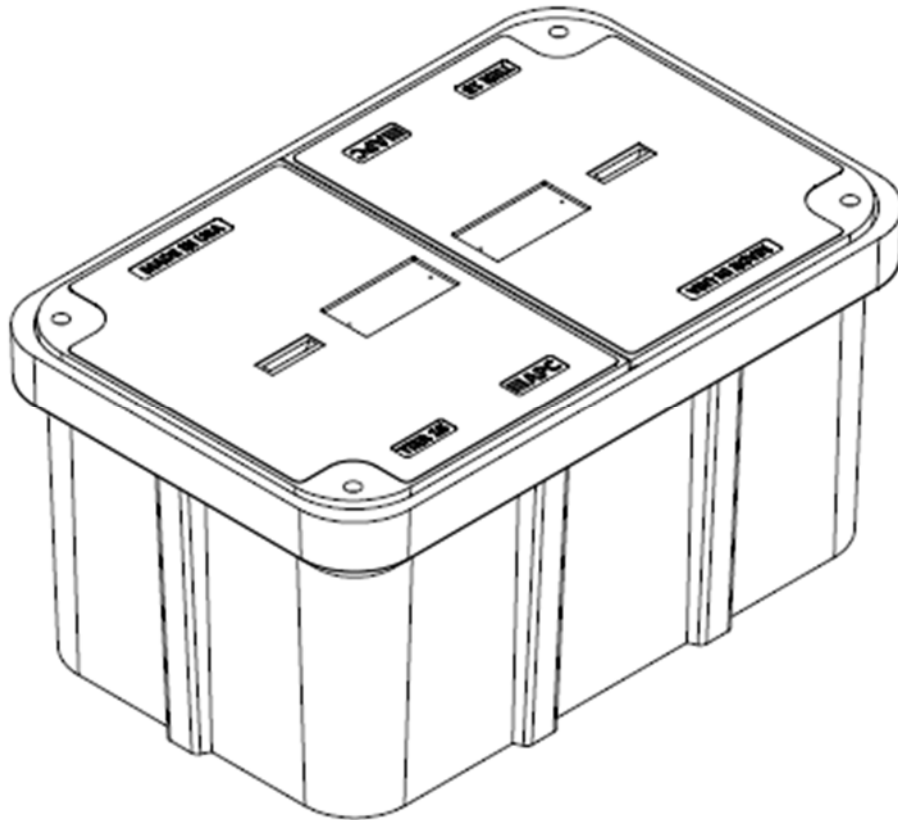

Description	Nominal Size	ANSI Tier	Part Number	Estimated Weight
PC Unit – TIER 15	30"x48"x18"	Tier 15	P304818HU15...	460 lbs.
PC Unit – TIER 22	30"x48"x18"	Tier 22	P304818HU22...	525 lbs.
PC Unit – TIER 15	30"x48"x24"	Tier 15	P304824HU15...	510 lbs.
PC Unit – TIER 22	30"x48"x24"	Tier 22	P304824HU22...	575 lbs.
PC Unit – TIER 15	30"x48"x36"	Tier 15	P304836HU15...	615 lbs.
PC Unit – TIER 22	30"x48"x36"	Tier 22	P304836HU22...	680 lbs.



30"x48" PC UNIT, 2PC TIER 15/22

18", 24", and 36" HEIGHT



AMERICAN POLYMER COMPANY

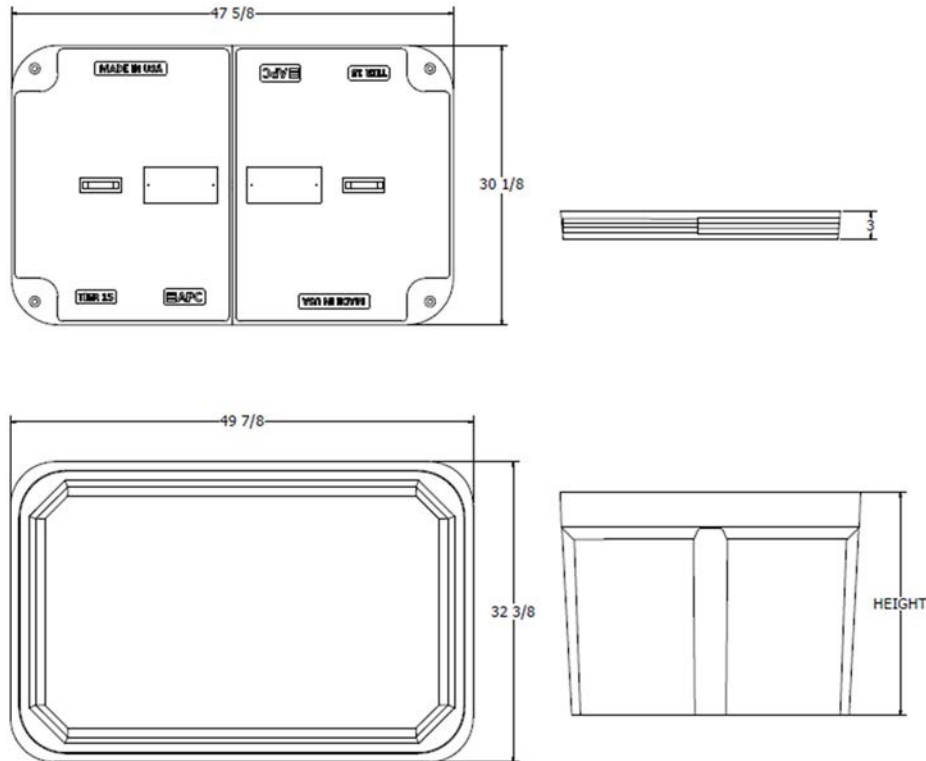

Components	Nominal Size	ANSI Tier	Part Number	Estimated Weight
Replacement Box	30"x48"x18"	Tier 22	P304818B22	185 lbs.
Replacement Box	30"x48"x24"	Tier 22	P304824B22	235 lbs.
Replacement Box	30"x48"x36"	Tier 22	P304836B22	340 lbs.
Replacement Lids - T15	30"x48" (half)	Tier 15	Various	150 lbs.
Replacement Lids - T22	30"x48" (half)	Tier 22	Various	170 lbs.

Bolt options

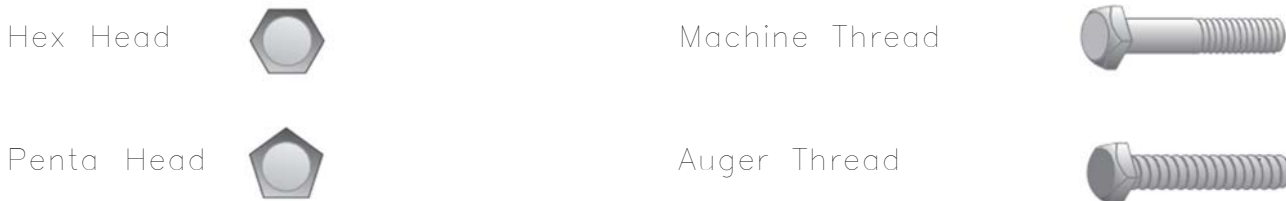

24"x36" PC UNIT, TIER 15/22
 18", 24", 30", and 36" HEIGHT



AMERICAN POLYMER COMPANY

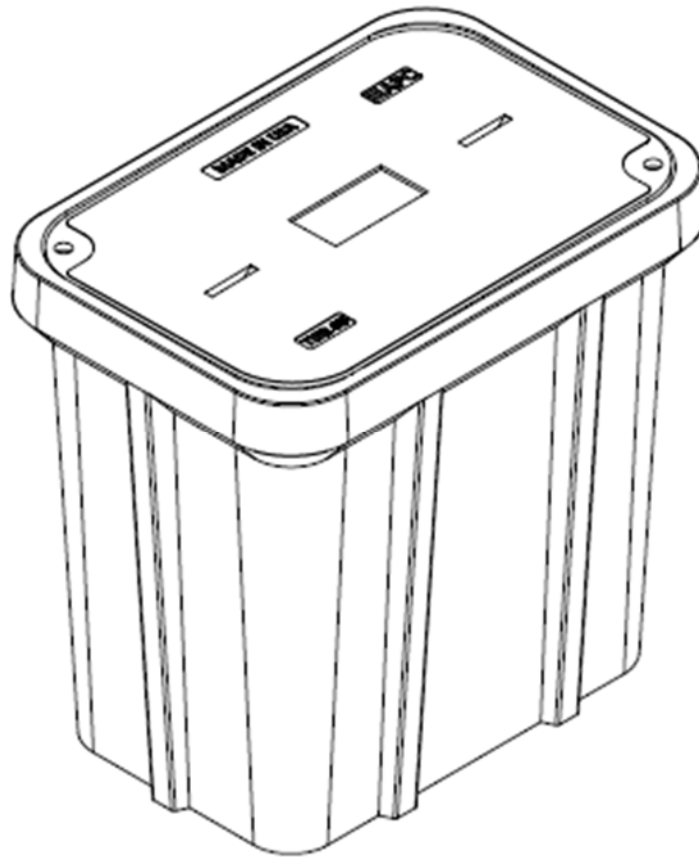

Description	Nominal Size	ANSI Tier	Part Number	Estimated Weight
PC Unit – TIER 15	24x36"x18"	Tier 15	P243618U15...	335 lbs.
PC Unit – TIER 22	24x36"x18"	Tier 22	P243618U22...	355 lbs.
PC Unit – TIER 15	24x36"x24"	Tier 15	P243624U15...	365 lbs.
PC Unit – TIER 22	24x36"x24"	Tier 22	P243624U22...	385 lbs.
PC Unit – TIER 15	24x36"x30"	Tier 15	P243630U15...	395 lbs.
PC Unit – TIER 22	24x36"x30"	Tier 22	P243630U22...	415 lbs.
PC Unit – TIER 15	24x36"x36"	Tier 15	P243636U15...	425 lbs.
PC Unit – TIER 22	24x36"x36"	Tier 22	P243636U22...	445 lbs.



24"x36" PC UNIT, TIER 15/22

18", 24", 30", and 36" HEIGHT



AMERICAN POLYMER COMPANY

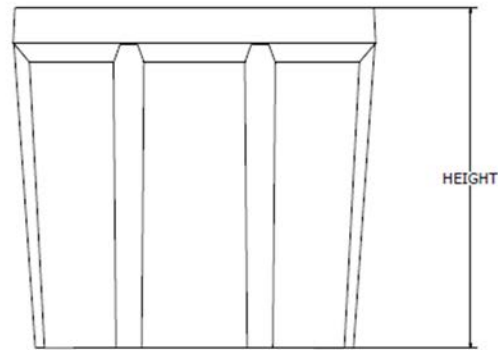
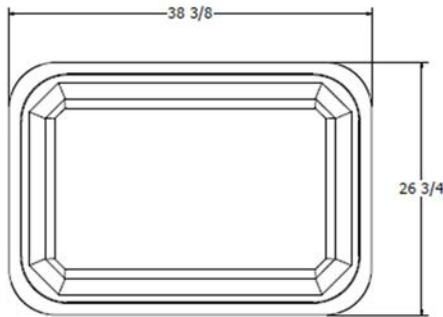
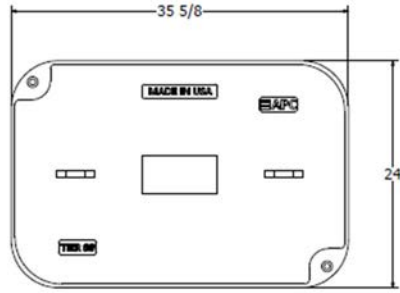

Components	Nominal Size	ANSI Tier	Part Number	Estimated Weight
Replacement Box	24"x36"x18"	Tier 22	P243618B22	165 lbs.
Replacement Box	24"x36"x24"	Tier 22	P243624B22	195 lbs.
Replacement Box	24"x36"x30"	Tier 22	P243630B22	225 lbs.
Replacement Box	24"x36"x36"	Tier 22	P243636B22	255 lbs.
Replacement Lids - T15	24"x36"	Tier 15	Various	170 lbs.
Replacement Lids - T22	24"x36"	Tier 22	Various	190 lbs.

Bolt options

Hex Head



Machine Thread



Penta Head



Auger Thread



17"x30" PC UNIT, TIER 15/22

12", 18", 24", and 30" HEIGHT



AMERICAN POLYMER COMPANY

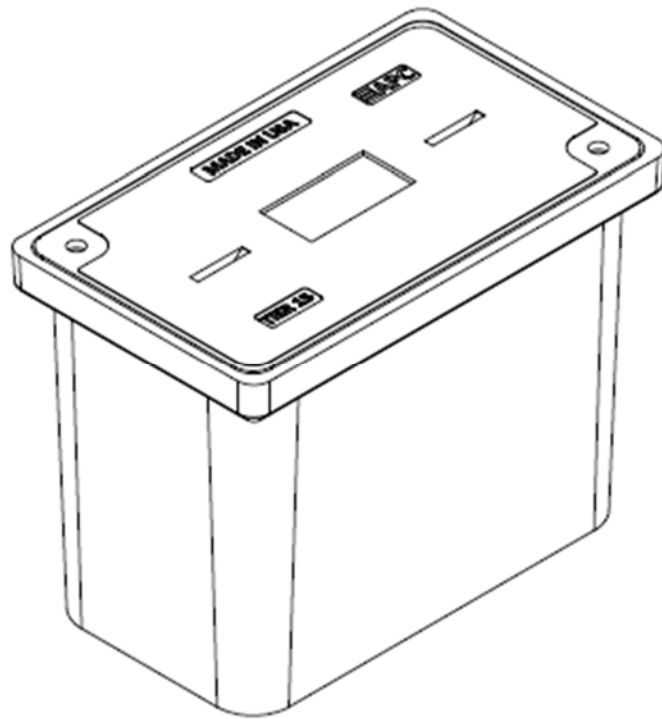

Description	Nominal Size	ANSI Tier	Part Number	Estimated Weight
PC Unit - TIER 15	17"x30"x12"	Tier 15	P173012U15...	138 lbs.
PC Unit - TIER 22	17"x30"x12"	Tier 22	P173012U22...	147 lbs.
PC Unit - TIER 15	17"x30"x18"	Tier 15	P173018U15...	172 lbs.
PC Unit - TIER 22	17"x30"x18"	Tier 22	P173018U22...	181 lbs.
PC Unit - TIER 15	17"x30"x24"	Tier 15	P173024U15...	192 lbs.
PC Unit - TIER 22	17"x30"x24"	Tier 22	P173024U22...	201 lbs.
PC Unit - TIER 15	17"x30"x30"	Tier 15	P173030U15...	217 lbs.
PC Unit - TIER 22	17"x30"x30"	Tier 22	P173030U22...	226 lbs.



17"x30" PC UNIT, TIER 15/22

12", 18", 24", and 30" HEIGHT



AMERICAN POLYMER COMPANY

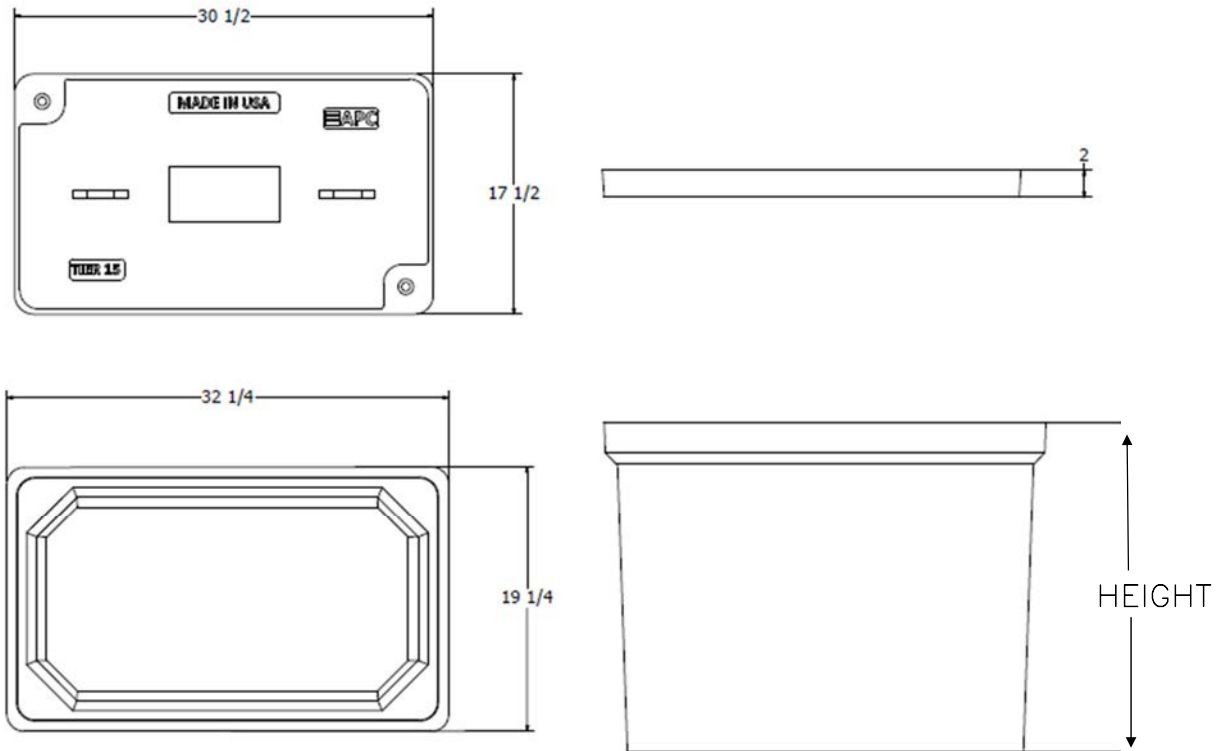

Components	Nominal Size	ANSI Tier	Part Number	Estimated Weight
Replacement Box	17"x30"x12"	Tier 22	P173012B22	66 lbs.
Replacement Box	17"x30"x18"	Tier 22	P173018B22	100 lbs.
Replacement Box	17"x30"x24"	Tier 22	P173024B22	120 lbs.
Replacement Box	17"x30"x30"	Tier 22	P173030B22	145 lbs.
Replacement Lids – T15	17"x30"	Tier 15	Various	72 lbs.
Replacement Lids – T22	17"x30"	Tier 22	Various	81 lbs.

Bolt options



Machine Thread



Auger Thread



33"x60" PC UNIT, 2PC TIER 15/22
36" HEIGHT



AMERICAN POLYMER COMPANY

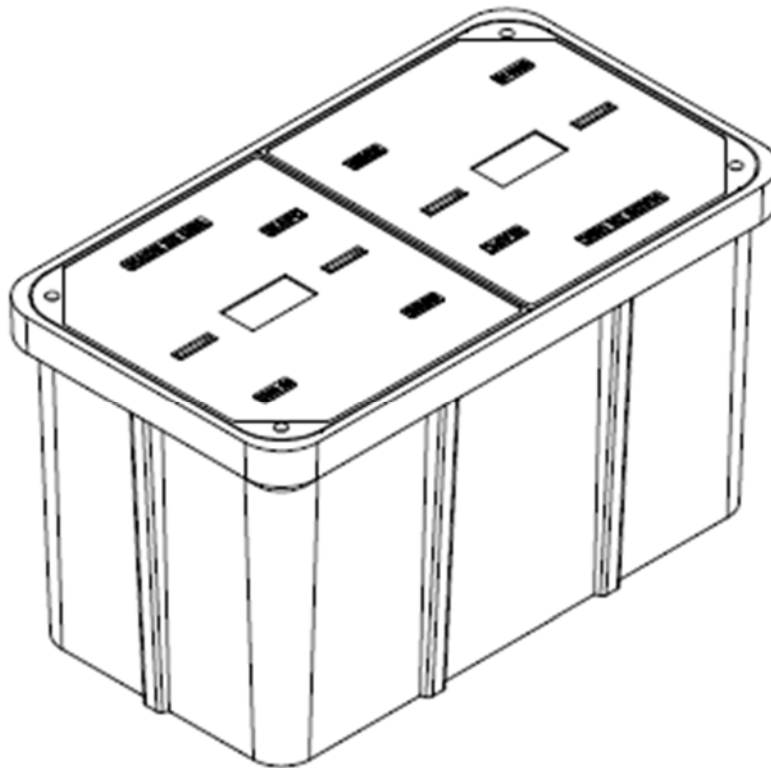

Description	Nominal Size	ANSI Tier	Part Number	Estimated Weight
PC Unit - TIER 15	33"x60"x36"	Tier 15	P336036U15...	930 lbs.
PC Unit - TIER 22	33"x60"x36"	Tier 22	P336036U22...	1030 lbs.



33"x60" PC UNIT, 2PC TIER 15/22

36" HEIGHT



AMERICAN POLYMER COMPANY

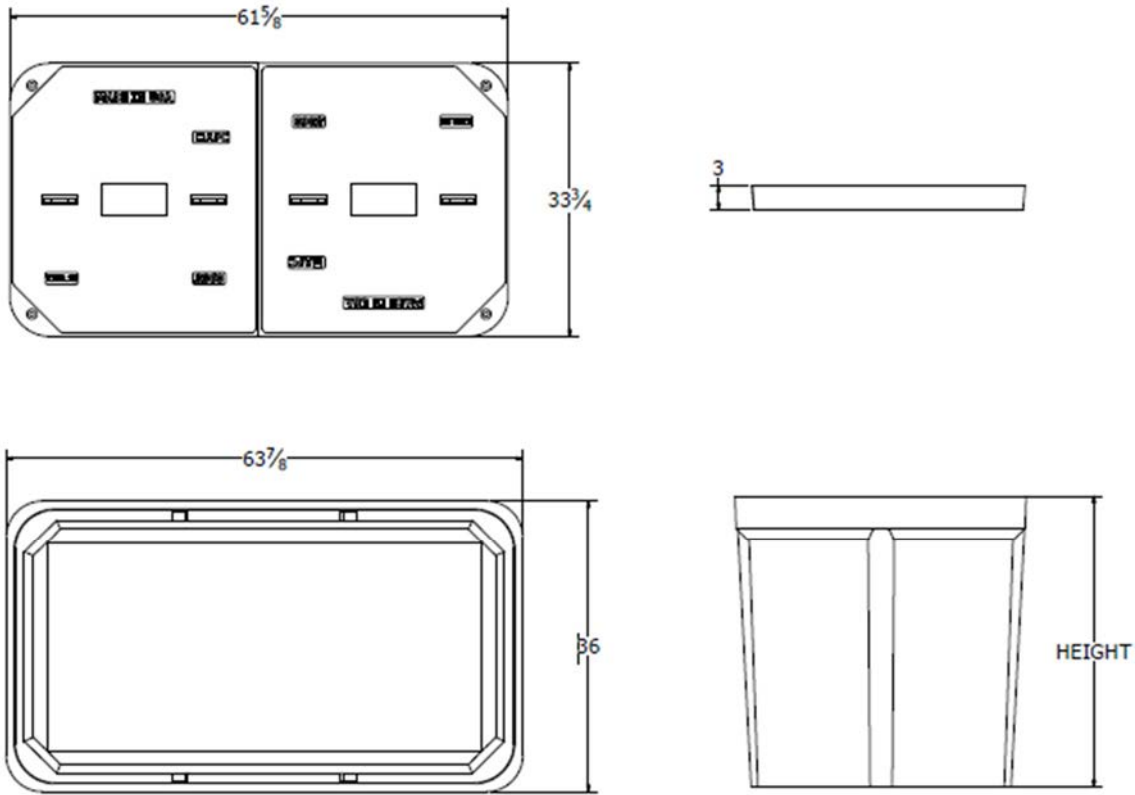

Components	Nominal Size	ANSI Tier	Part Number	Estimated Weight
Replacement Box	33"x60"x36"	Tier 22	P336036B22	530 lbs.
Replacement Lids - T15	33"x60" (half)	Tier 15	Various	200 lbs.
Replacement Lids - T22	33"x60" (half)	Tier 22	Various	250 lbs.

Bolt options

Hex Head



Machine Thread



Penta Head



Auger Thread



Speed (MPH) Prior To Road Work	SIGN SPACING, FT.		Must be Approved by an Engineer				
	Non-Divided Highways	Divided Highways	BUFFER SPACE, FT.	TAPER LENGTH, FT.	CHANNELIZING SPACING, FT.		
	Length	Shoulder (10 ft. Width)	Lane (12 ft. Width)	Through Taper	Through Buffer/Work Area		
0-35	200	200	250	70	245	35	50
40-45	350	500	360	150	540	40	80
50-55	500	1000	495	185	660	50	100
60-70	SA-1000, SB-1500, SC-2640		730	235	840	60	120
Urban Low Speed - 100 FT							

APPROVED/ACCEPTED BY:
ENGINEER, OWNER, or PRIME CONTRACTOR
 Check for Notice to Proceed.

Signature: _____

Company: _____

Date: 12/12/2023 **Project:** BLN01b-F13. N Crescent Rd TCP :
Traffic Control Suggestion For: ATLANTIC ENGINEERING (AEG) :
By: Road Runner Safety Services, Inc. : Nathan

Comments:
 Drawing not to scale. Traffic control plan must be approved by an engineer. This is a suggestion only. Road Runners Safety Services, Inc. has no liability for this suggested traffic control plan. Actual placement and spacing of all traffic control devices will depend on field conditions and must conform to MUTCD standards.

- Legend**
- ADA Barricade
 - Channelizer
 - Conduit
 - Flagger (Person)
 - Sign
 - Vault
 - Work Area

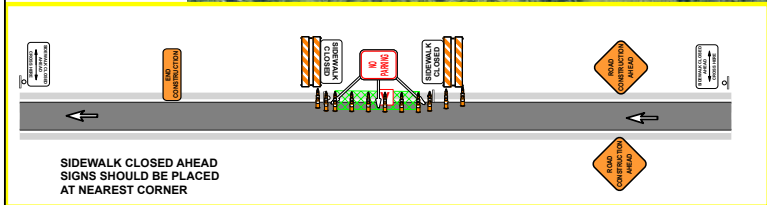
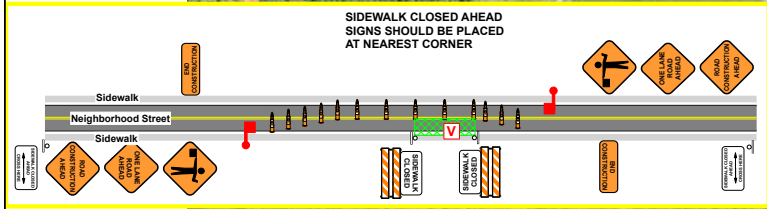

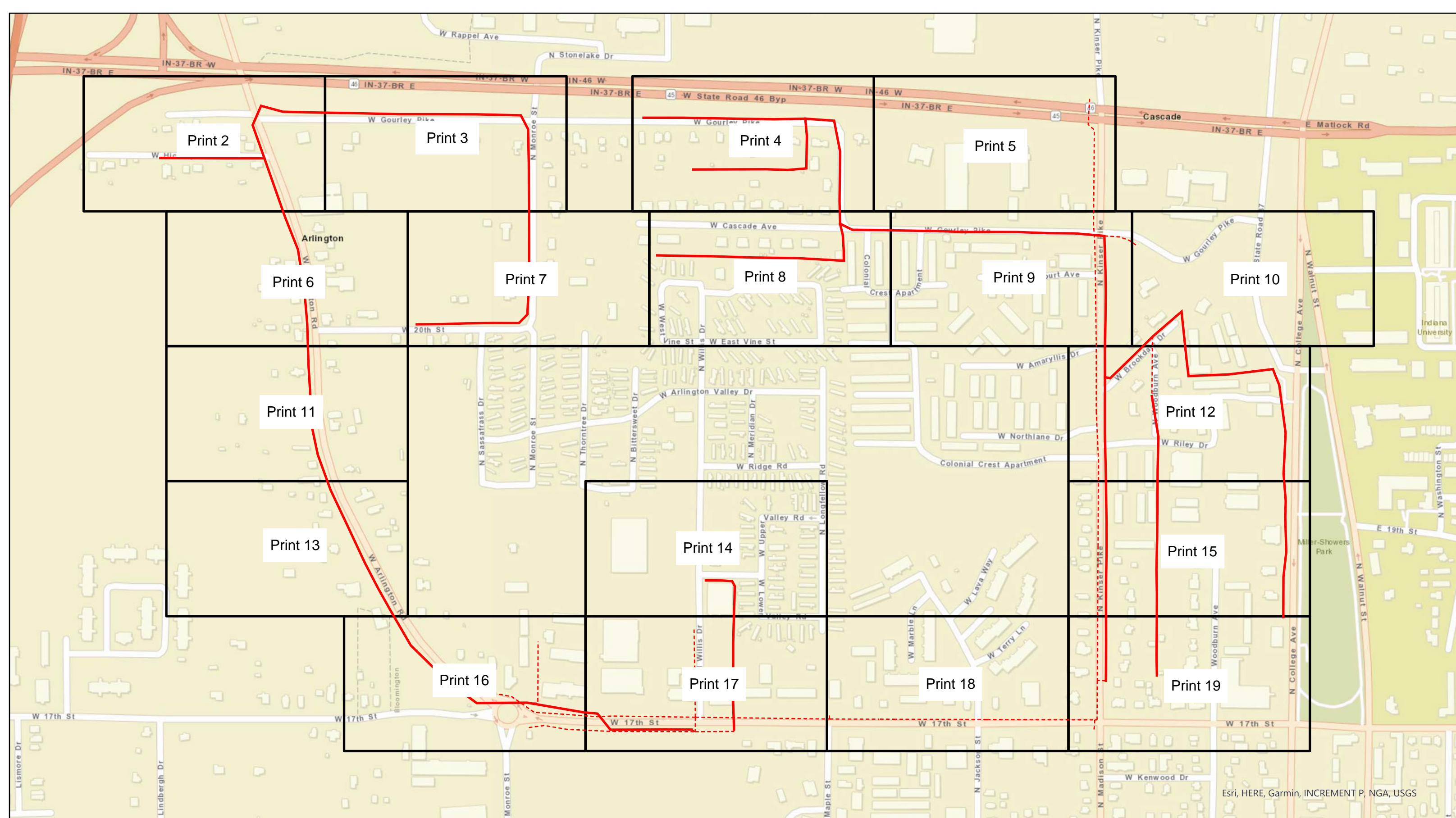

Esri, HERE, Garmin, INCREMENT P, NGA, USGS



Legend BLN01a-F06_Hoosier Court Ave

- Overhead Strand
- - - Conduit
- Grids

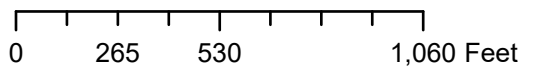

City of Bloomington, IN Permit:
Design View

INI	BY	DATE	DESCRIPTION



N State Road 37 Ramp

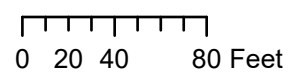
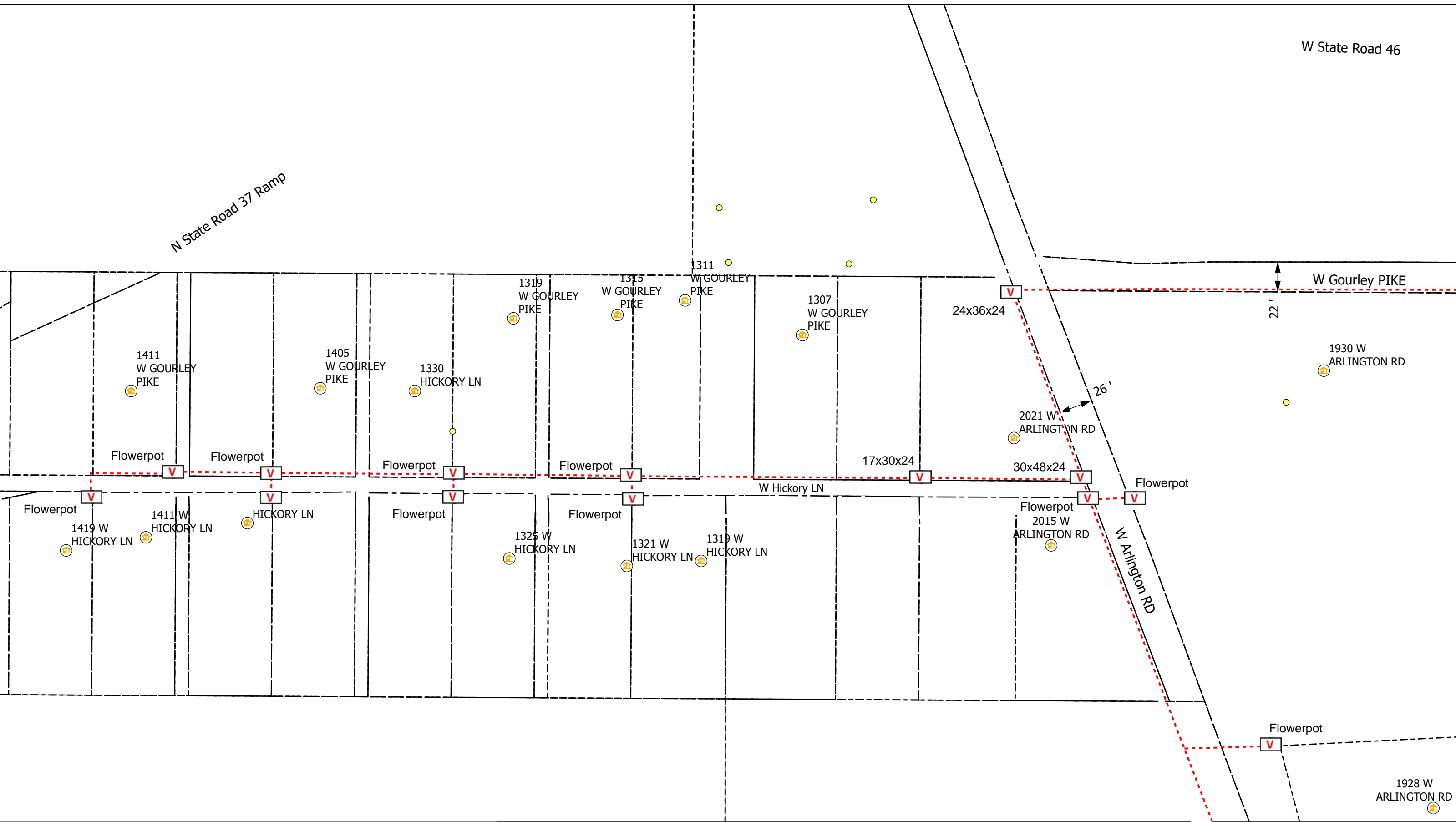

Legend

- Poles
- Ⓡ Risers
- Ⓜ Sidewalk
- V Vaults
- 🏠 Address
- Bloomington_Parcels
- Overhead Strand
- Conduit
- Y Anchor
- Grids

All Flowerpots 12" DIA



City of Bloomington, IN Permit:
Design View

INI	BY	DATE	DESCRIPTION



W State Road 46

W Gourley PIKE

30x48x24

Flowerpot

Flowerpot

1235
W GOURLEY
PIKE

1109
W GOURLEY
PIKE

2025 N
MONROE ST

1019
W GOURLEY
PIKE 1015
W GOURLEY
PIKE

2010 N
MONROE ST

Flowerpot

1920 N
MONROE ST

1918 N
MONROE ST

26'











25'

N Montoe ST

Flowerpot



Legend

-  Poles
-  Risers
-  Vaults
-  Address
-  Overhead Strand
-  Anchor
-  Conduit
-  Sidewalk
-  Bloomington_Parcels
-  Grids

All Flowerpots 12" DIA

N



City of Bloomington, IN Permit:
Design View

INI	BY	DATE	DESCRIPTION



W State Road 46

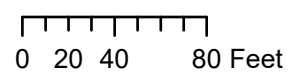
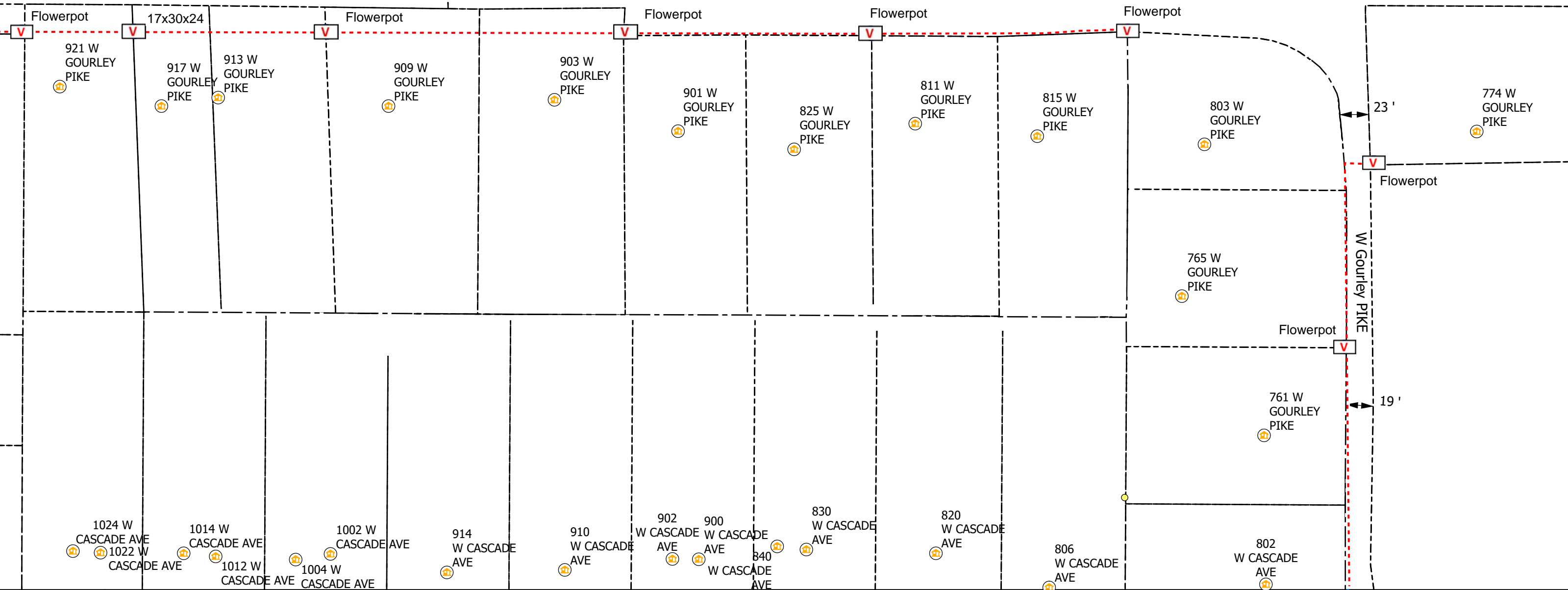

Legend

- Poles
- V Vaults
- Overhead Strand
- - - Conduit
- Ⓡ Risers
- 🏠 Address
- Y Anchor
- ↖ Sidewalk
- Bloomington_Parcels
- Grids

All Flowerpots 12" DIA



City of Bloomington, IN Permit:
Design View

INI	BY	DATE	DESCRIPTION



W State Road 46

700 W
GOURLEY
PIKE

606 W
GOURLEY
PIKE

522 W
GOURLEY
PIKE

1705
N KINSER
PIKE

N Kinser PIKE

Continues into
INDOT permit

783'

75'











17x30x24

17x30x24



0 20 40 80 Feet

Legend

-  Poles
-  Risers
-  Sidewalk
-  Vaults
-  Address
-  Bloomington_Parcels
-  Overhead Strand
-  Anchor
-  Conduit
-  Grids

All Flowerpots 12" DIA



City of Bloomington, IN Permit:
Design View

INI	BY	DATE	DESCRIPTION



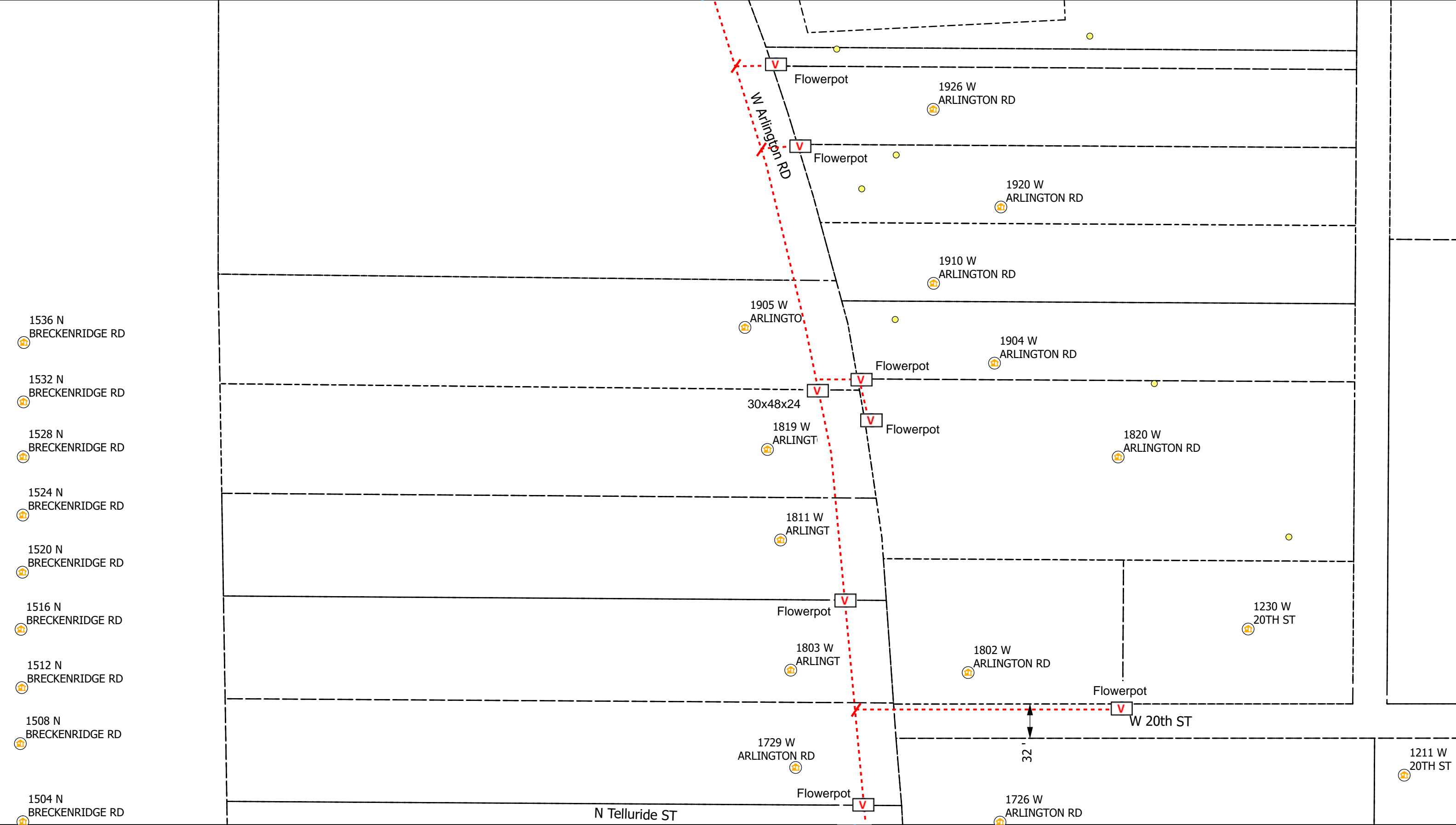

- Legend**
- Poles
 - Ⓡ Risers
 - Ⓜ Sidewalk
 - V Vaults
 - 🏠 Address
 - Bloomington_Parcels
 - Overhead Strand
 - Conduit
 - Y Anchor
 - Grids

All Flowerpots 12" DIA



City of Bloomington, IN Permit:
Design View

INI	BY	DATE	DESCRIPTION



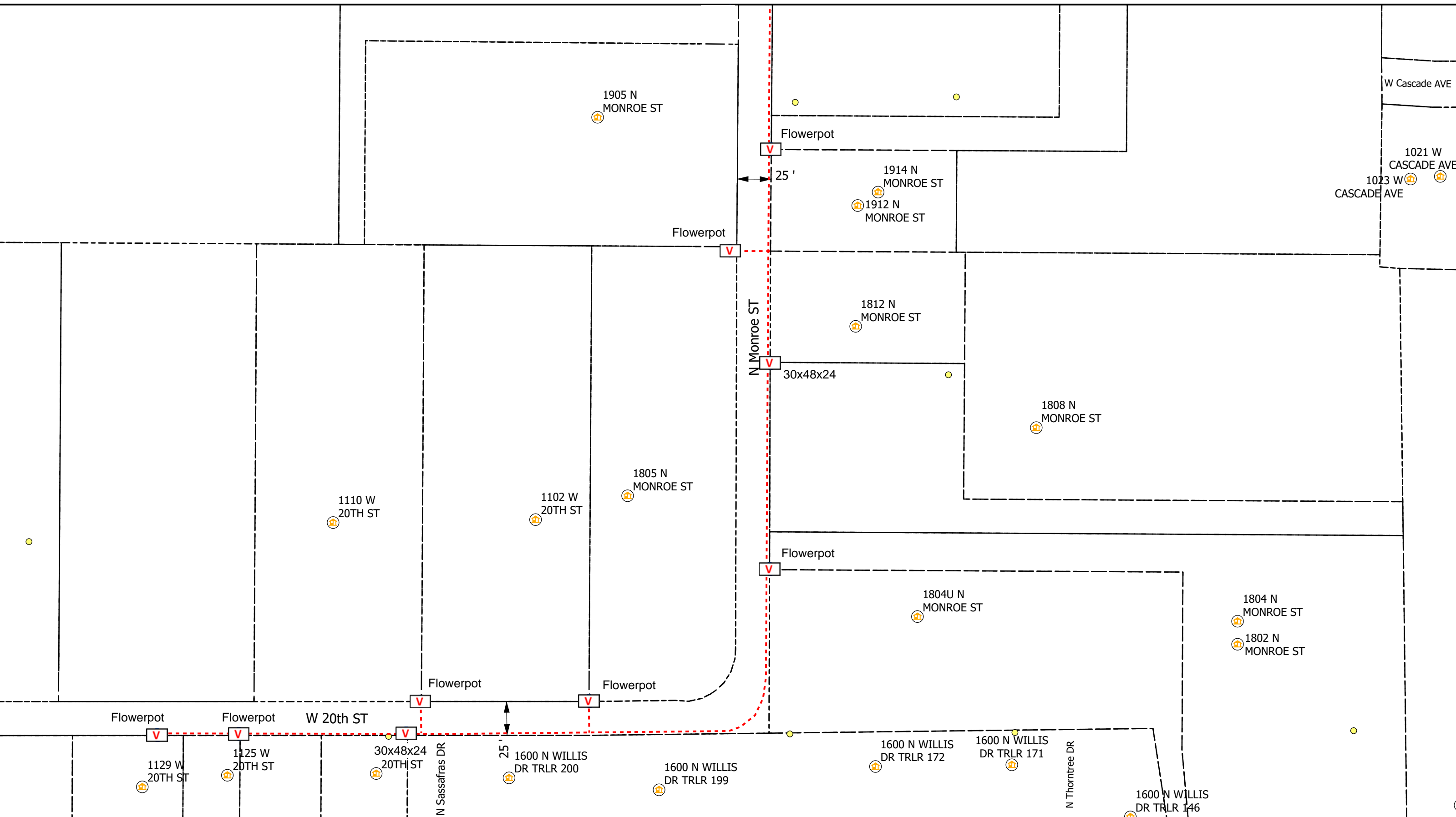

Legend

- Poles
- V Vaults
- Overhead Strand
- - - Conduit
- ⊕ Risers
- Ⓜ Address
- Y Anchor
- ↖ Sidewalk
- Bloomington_Parcels
- Grids

All Flowerpots 12" DIA



City of Bloomington, IN Permit:
Design View

INI	BY	DATE	DESCRIPTION



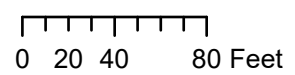
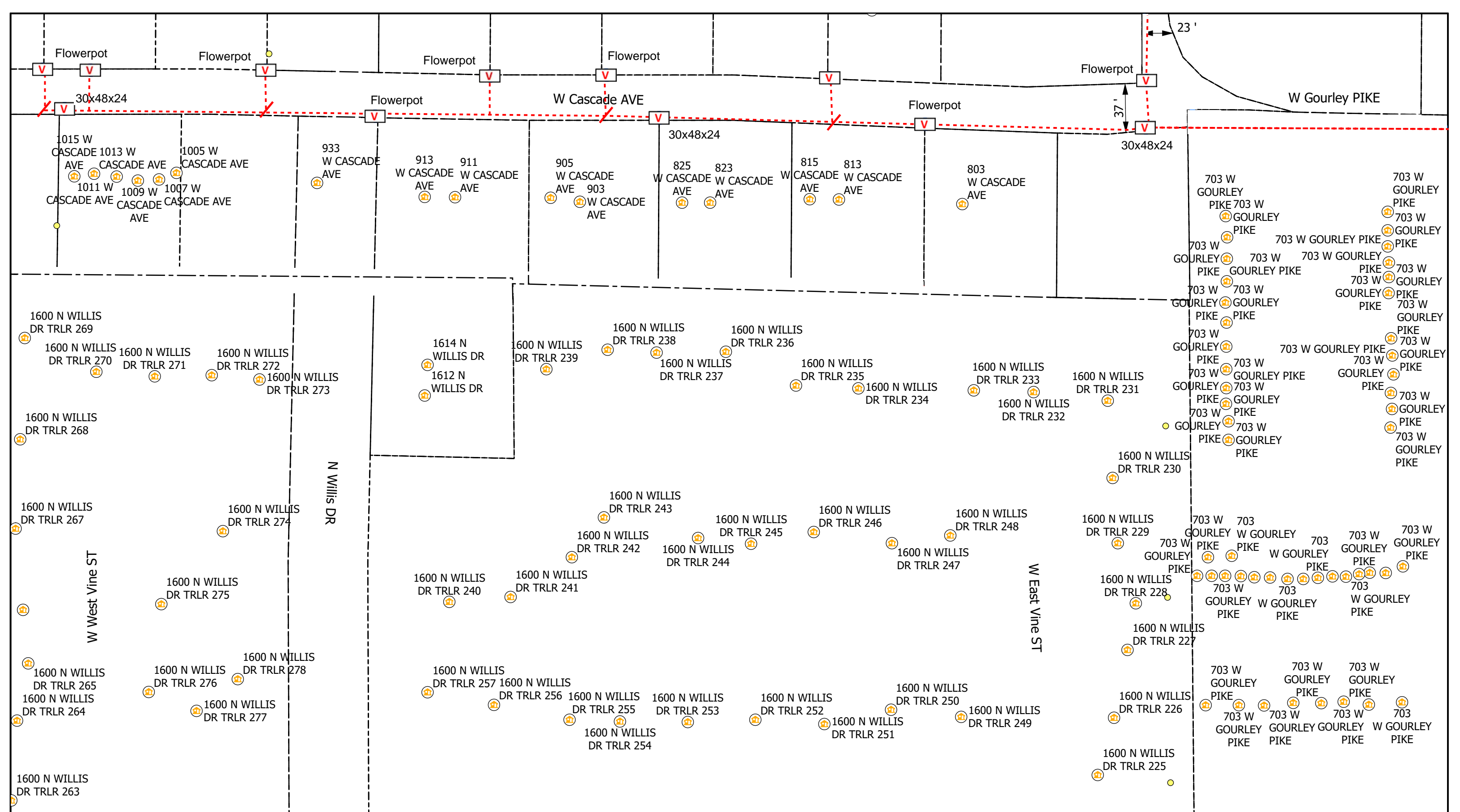

Legend

- Poles
- V Vaults
- Overhead Strand
- - - Conduit
- Ⓡ Risers
- Ⓜ Address
- Y Anchor
- ↖ Sidewalk
- Bloomington_Parcels
- Grids

All Flowerpots 12" DIA



City of Bloomington, IN Permit:
Design View





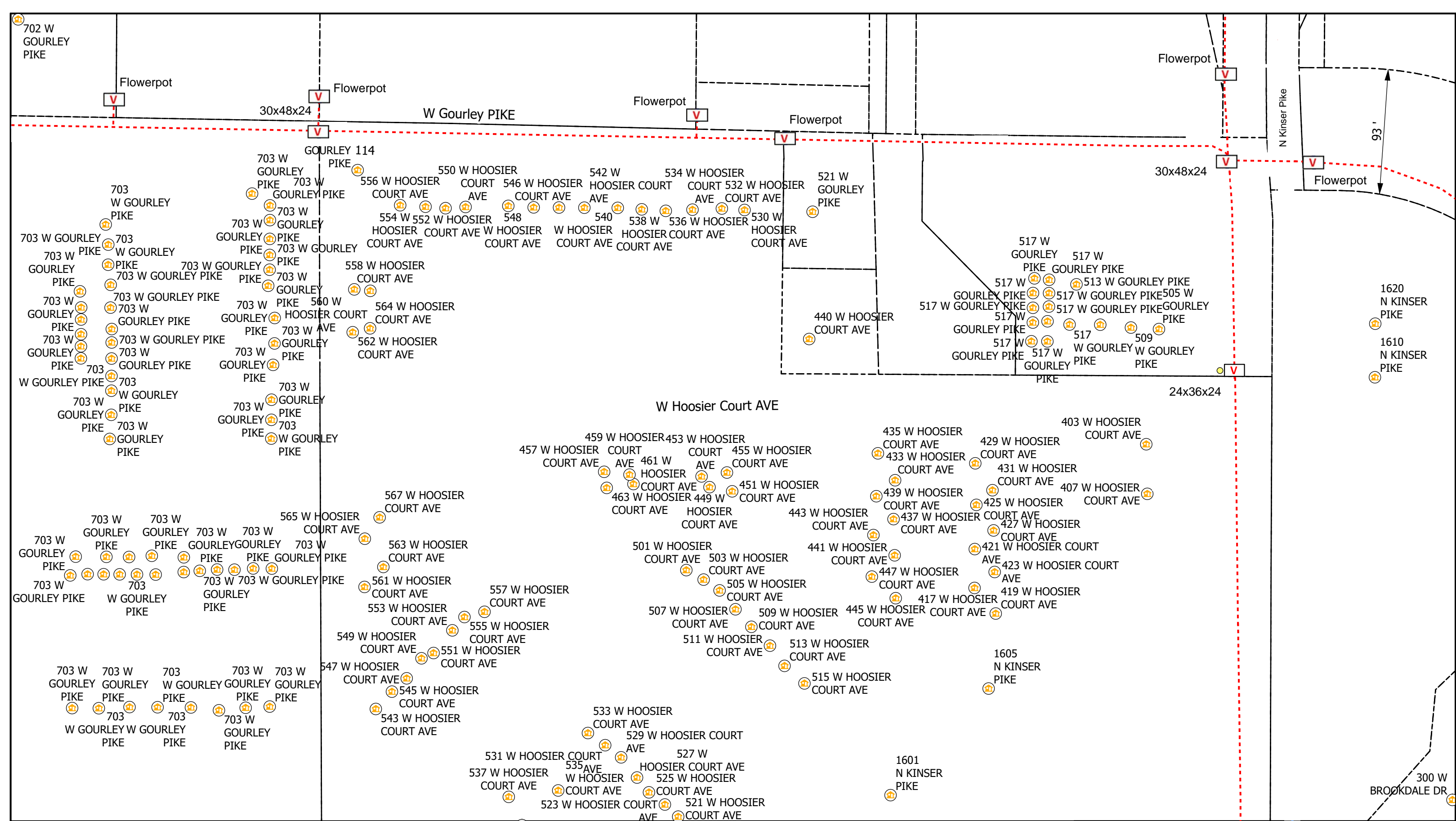





INI	BY	DATE	DESCRIPTION





0 20 40 80 Feet

Legend

-  Poles
-  Vaults
-  Overhead Strand
-  Conduit
-  Risers
-  Address
-  Anchor
-  Sidewalk
-  Bloomington_Parcels
-  Grids

All Flowerpots 12" DIA

N



City of Bloomington, IN Permit:
Design View

INI	BY	DATE	DESCRIPTION



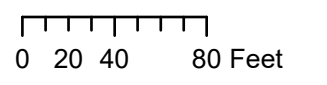
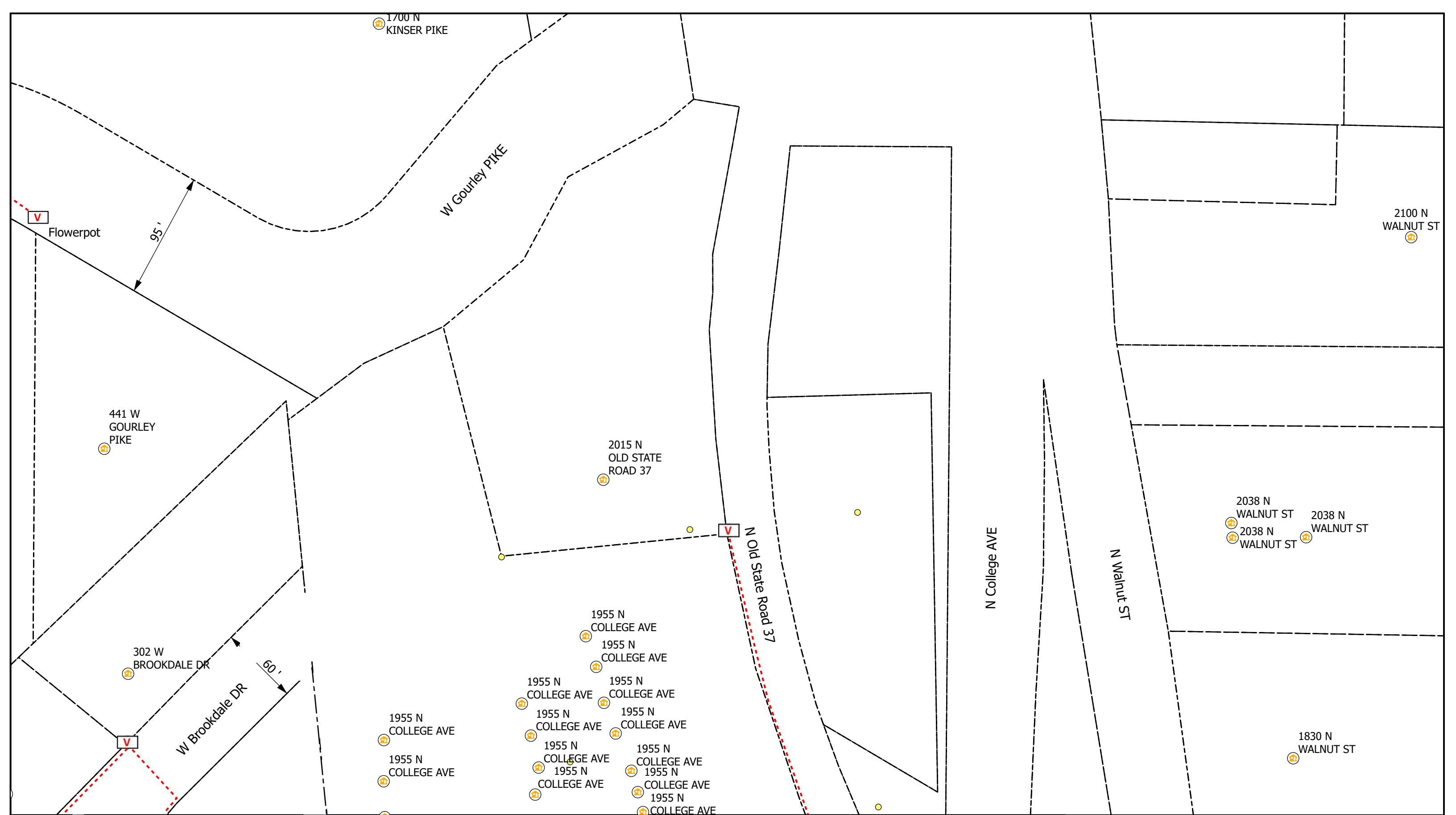

Legend

- Poles
- Ⓡ Risers
- Ⓜ Vaults
- Overhead Strand
- - - Conduit
- 🏠 Address
- ⚓ Anchor
- ↖ Sidewalk
- Bloomington_Parcels
- Grids

All Flowerpots 12" DIA



City of Bloomington, IN Permit:
Design View

INI	BY	DATE	DESCRIPTION



1564 N BRECKENRIDGE RD
 1560 N TELLURIDE ST
 1568 N TELLURIDE ST

1719 W ARLINGTON RD
 1719 W ARLINGTON RD
 1719 W ARLINGTC

Flowerpot
 1720 W ARLINGTON RD

W Vail ST

1303 N DENVER RD
 1305 N DENVER RD
 1307 N DENVER RD
 1309 N DENVER RD
 1311 N DENVER RD
 1313 N DENVER RD

1619 W ARLINGTON RD

Flowerpot
 1614 W ARLINGTON RD
 1614 W ARLINGTON RD
 1614 W ARLINGTON RD
 1614 W ARLINGTON RD
 1614 W ARLINGTON RD
 1614 W ARLINGTON RD
 1614 W ARLINGTON RD
 1614 W ARLINGTON RD
 1614 W ARLINGTON RD

1605B ARLING

Flowerpot
 Flowerpot
 Flowerpot

1530 W ARLINGTON RD

1604 W ARLINGTON RD

N Denver RD
 1321 N DENVER RD
 1323 N DENVER RD

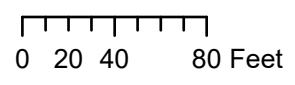

Legend

- Poles
- Ⓡ Risers
- Ⓜ Sidewalk
- V Vaults
- 🏠 Address
- Bloomington_Parcels
- Overhead Strand
- Conduit
- Y Anchor
- Grids

All Flowerpots 12" DIA



City of Bloomington, IN Permit:
 Design View

INI	BY	DATE	DESCRIPTION



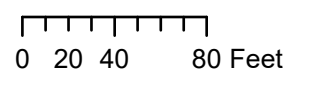
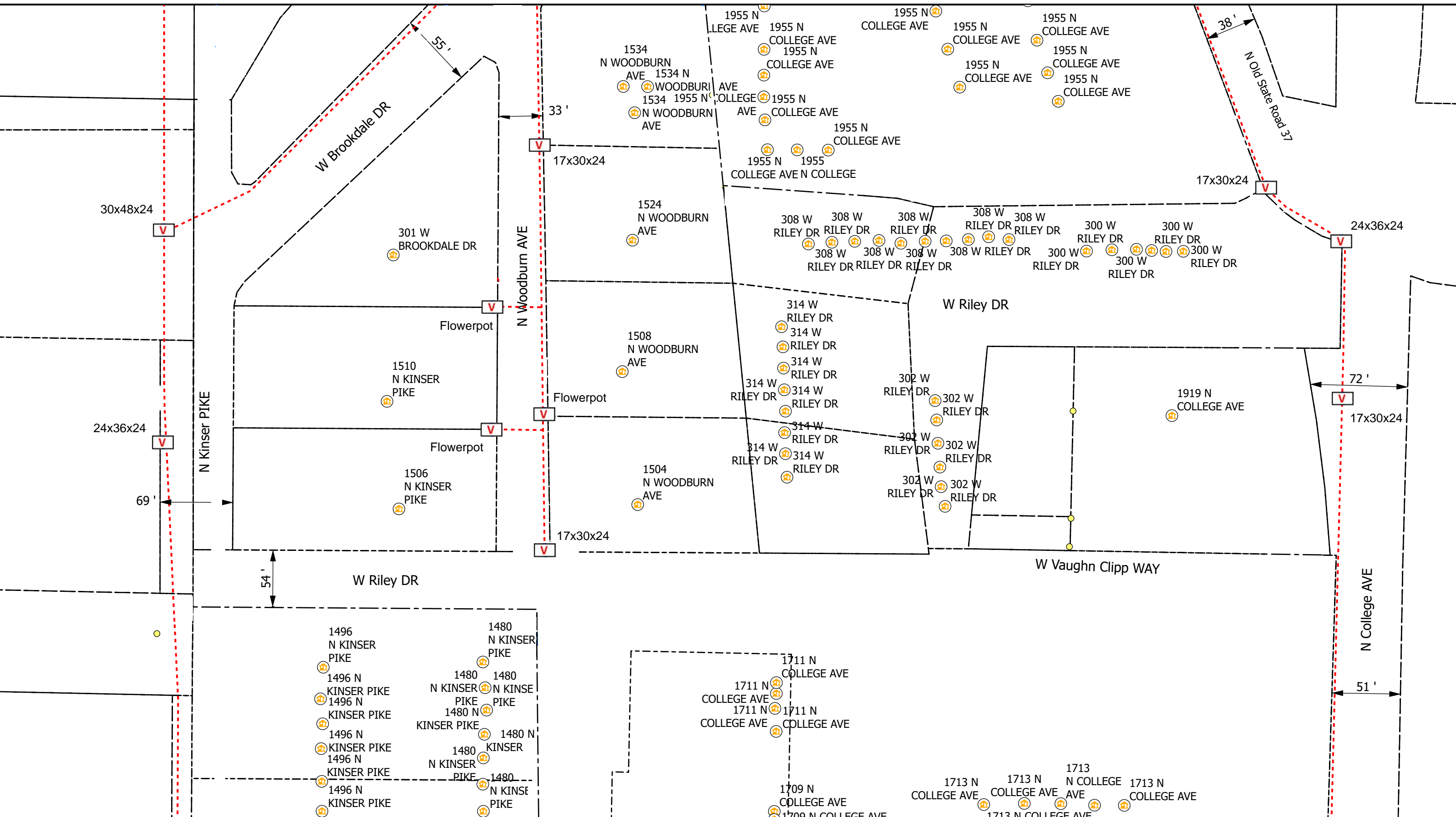

Legend

- Poles
- Vaults
- Overhead Strand
- Conduit
- Risers
- Address
- Anchor
- Sidewalk
- Bloomington_Parcels
- Grids

All Flowerpots 12" DIA



City of Bloomington, IN Permit:
Design View

INI	BY	DATE	DESCRIPTION



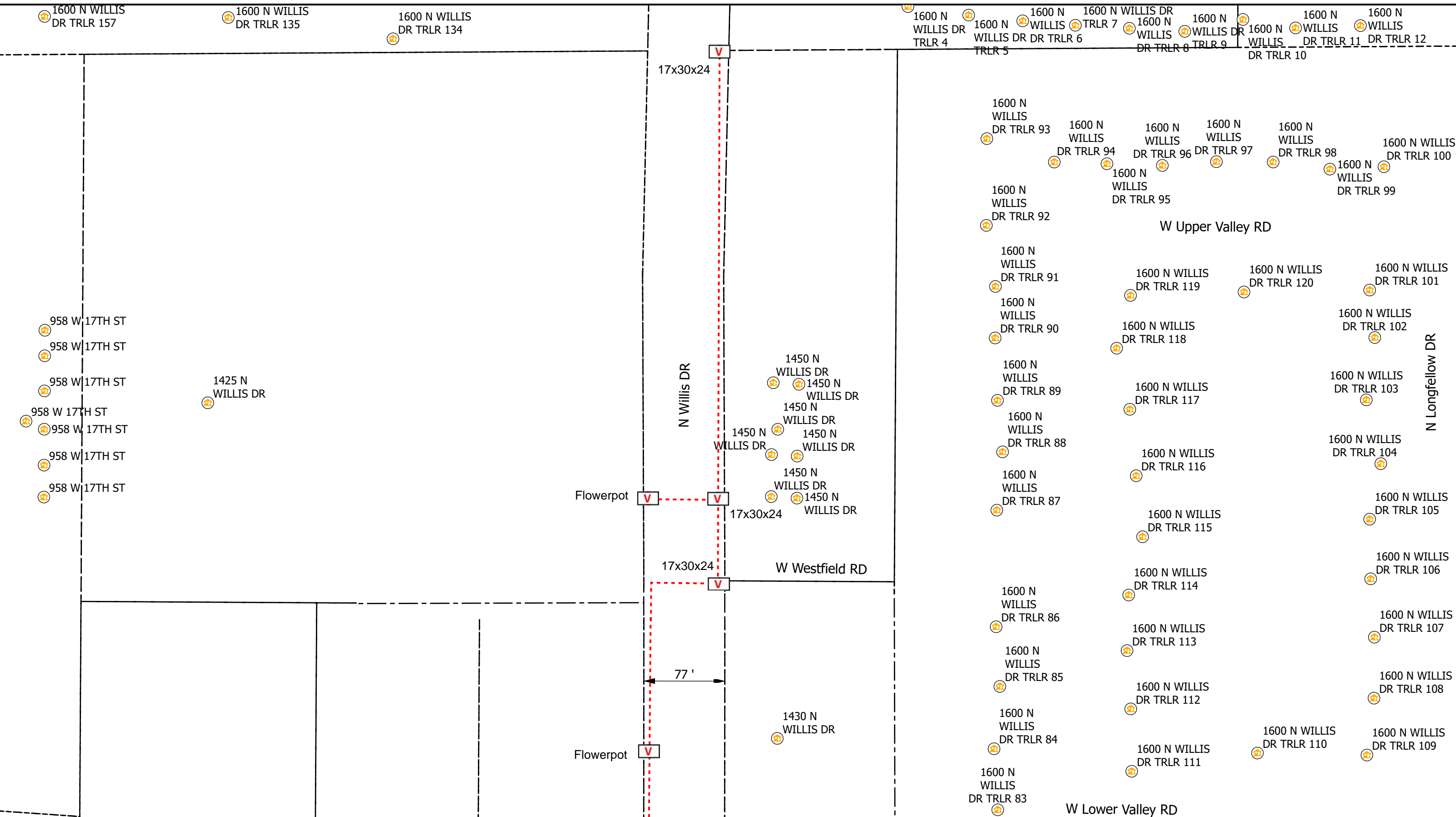

0 20 40 80 Feet

Legend

- Poles
- V Vaults
- Overhead Strand
- Conduit
- R Risers
- Ⓜ Address
- Y Anchor
- ↖ Sidewalk
- Bloomington_Parcels
- Grids

All Flowerpots 12" DIA



City of Bloomington, IN Permit:
Design View

INI	BY	DATE	DESCRIPTION



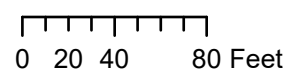
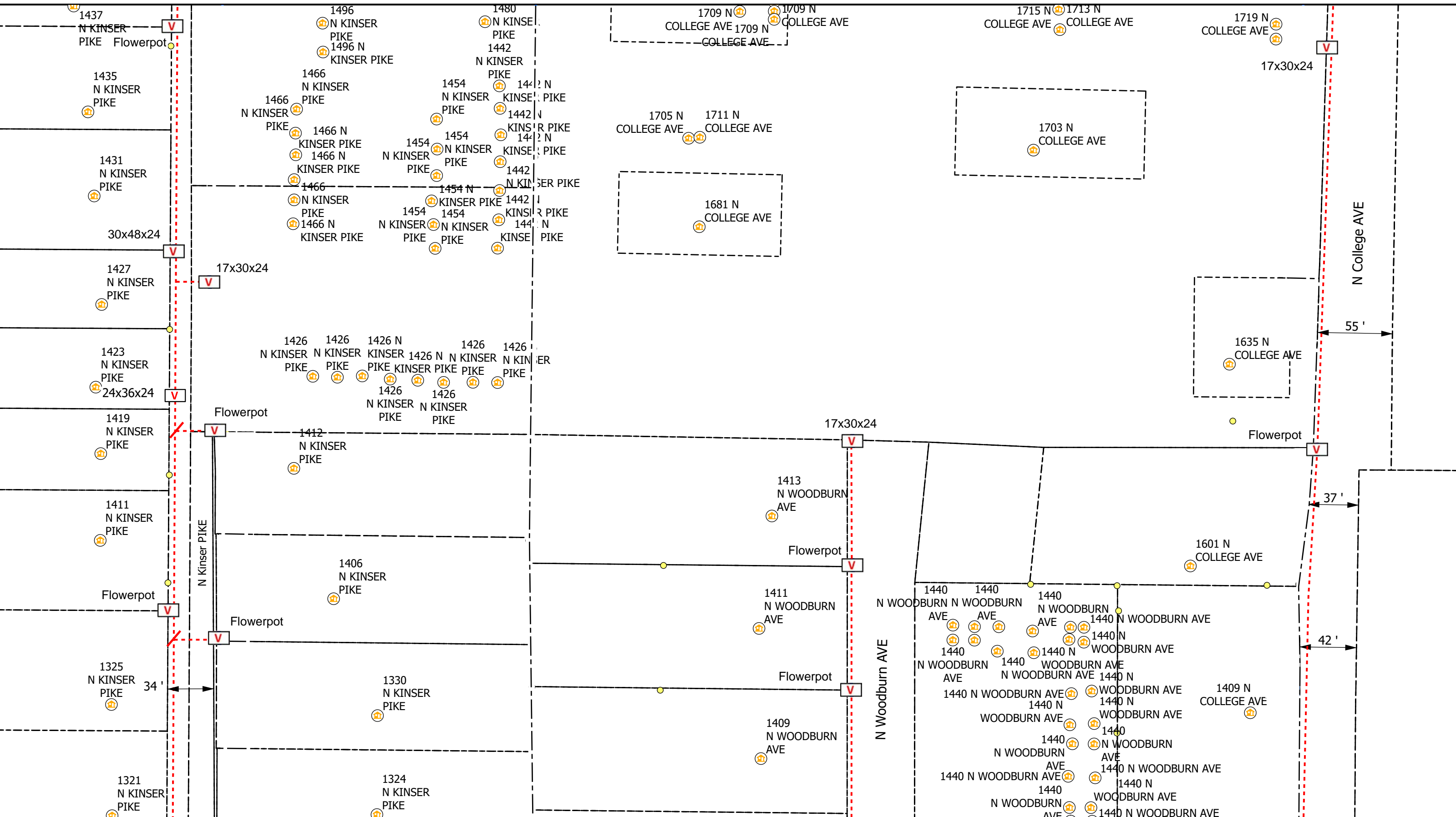

Legend

- Poles
- Ⓡ Risers
- ⬆ Sidewalk
- V Vaults
- Overhead Strand
- - - Conduit
- 🏠 Address
- Y Anchor
- Bloomington_Parcels
- Grids

All Flowerpots 12" DIA



City of Bloomington, IN Permit:
Design View

INI	BY	DATE	DESCRIPTION



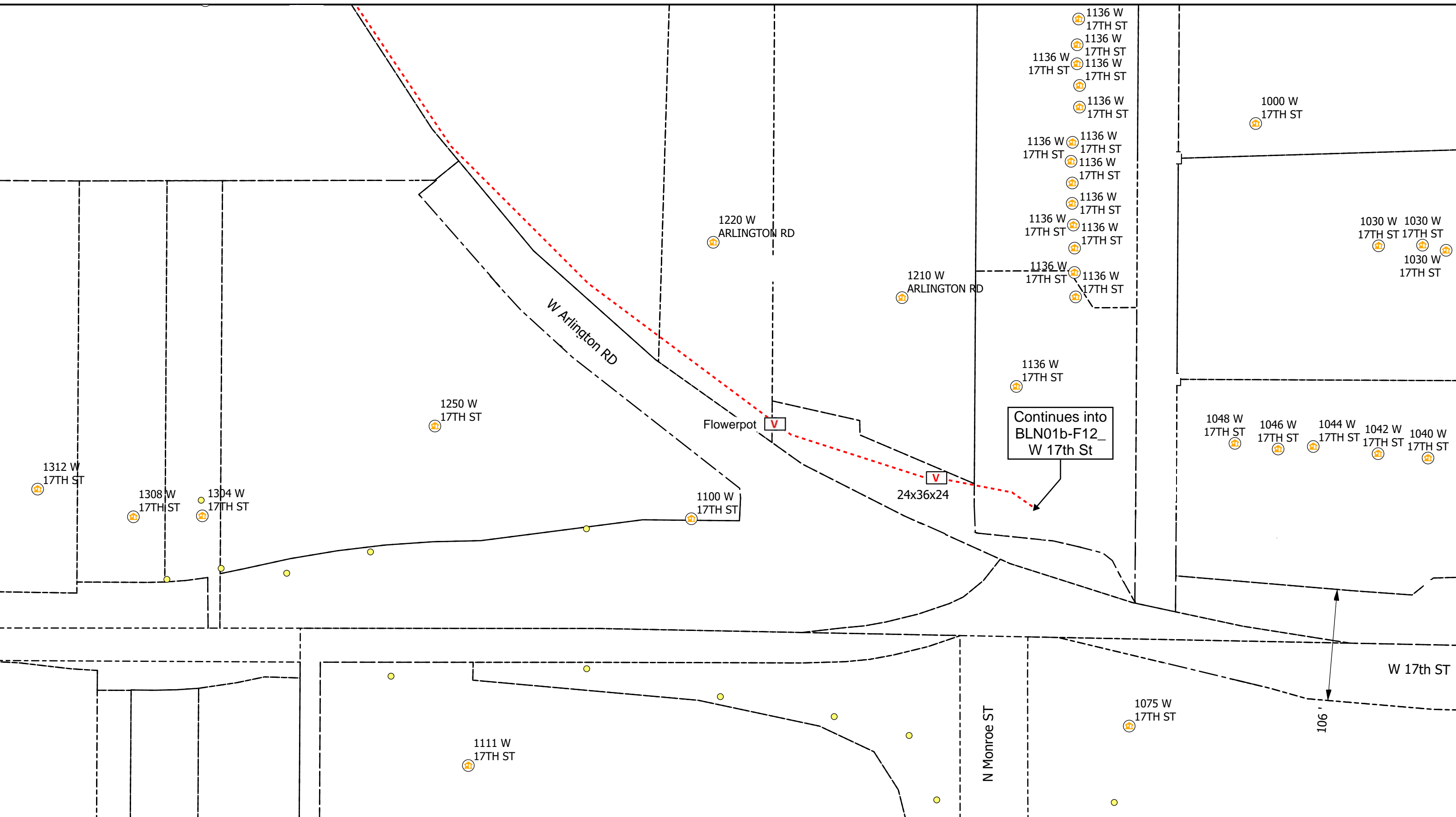

AEG

0 20 40 80 Feet

Legend

- Poles
- Vaults
- Overhead Strand
- Conduit
- Risers
- Address
- Anchor
- Sidewalk
- Bloomington_Parcels
- Grids

All Flowerpots 12" DIA

All Flowerpots 12" DIA

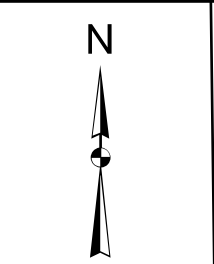

City of Bloomington, IN Permit:
Design View

INI	BY	DATE	DESCRIPTION

Indiana 811

Print 16 of 19

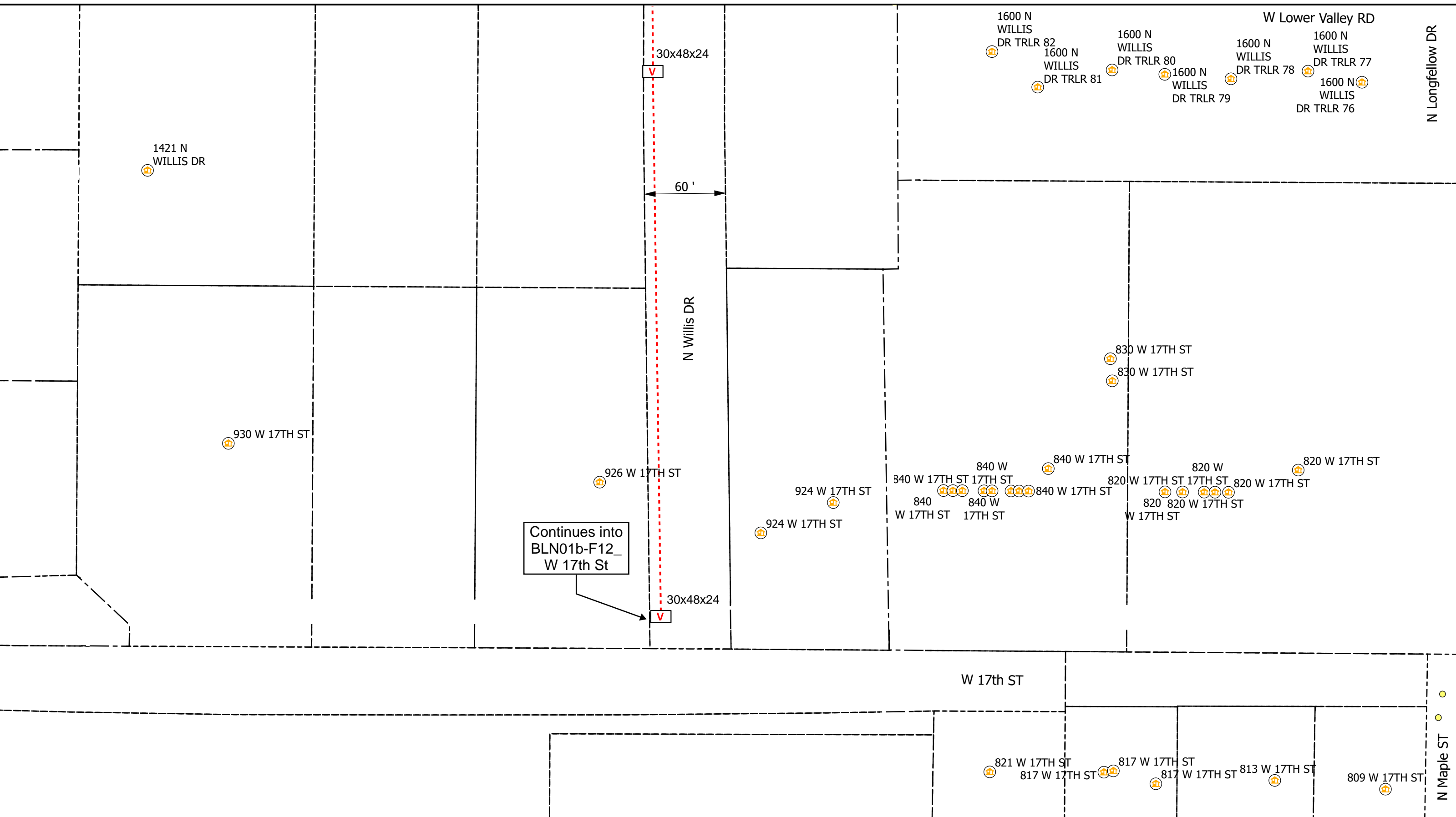

Legend

- Poles
- V Vaults
- Overhead Strand
- Conduit
- R Risers
- A Address
- Y Anchor
- └─┘ Sidewalk
- Bloomington_Parcels
- Grids

All Flowerpots 12" DIA



City of Bloomington, IN Permit:
Design View

INI	BY	DATE	DESCRIPTION



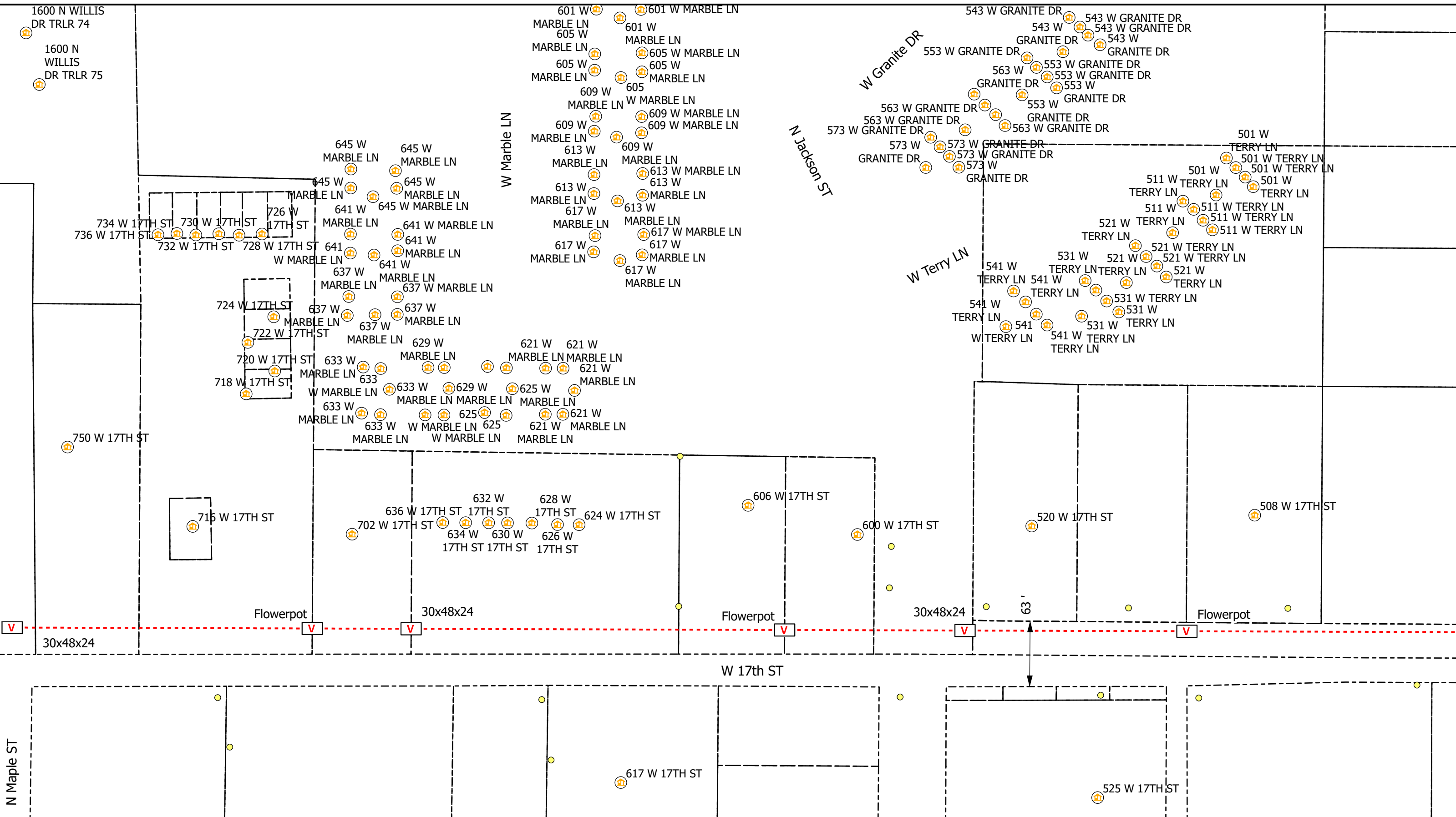

Legend

- Poles
- ⓧ Risers
- Ⓜ Address
- Ⓨ Anchor
- ⓧ Vaults
- Overhead Strand
- - - Conduit
- ↖ Sidewalk
- ⓧ Bloomington_Parcels
- ⓧ Grids

All Flowerpots 12" DIA

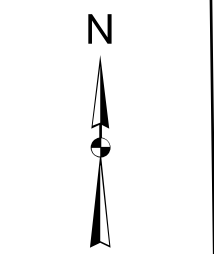

City of Bloomington, IN Permit:
Design View

INI	BY	DATE	DESCRIPTION

Print 18 of 19

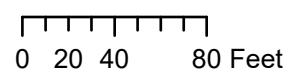
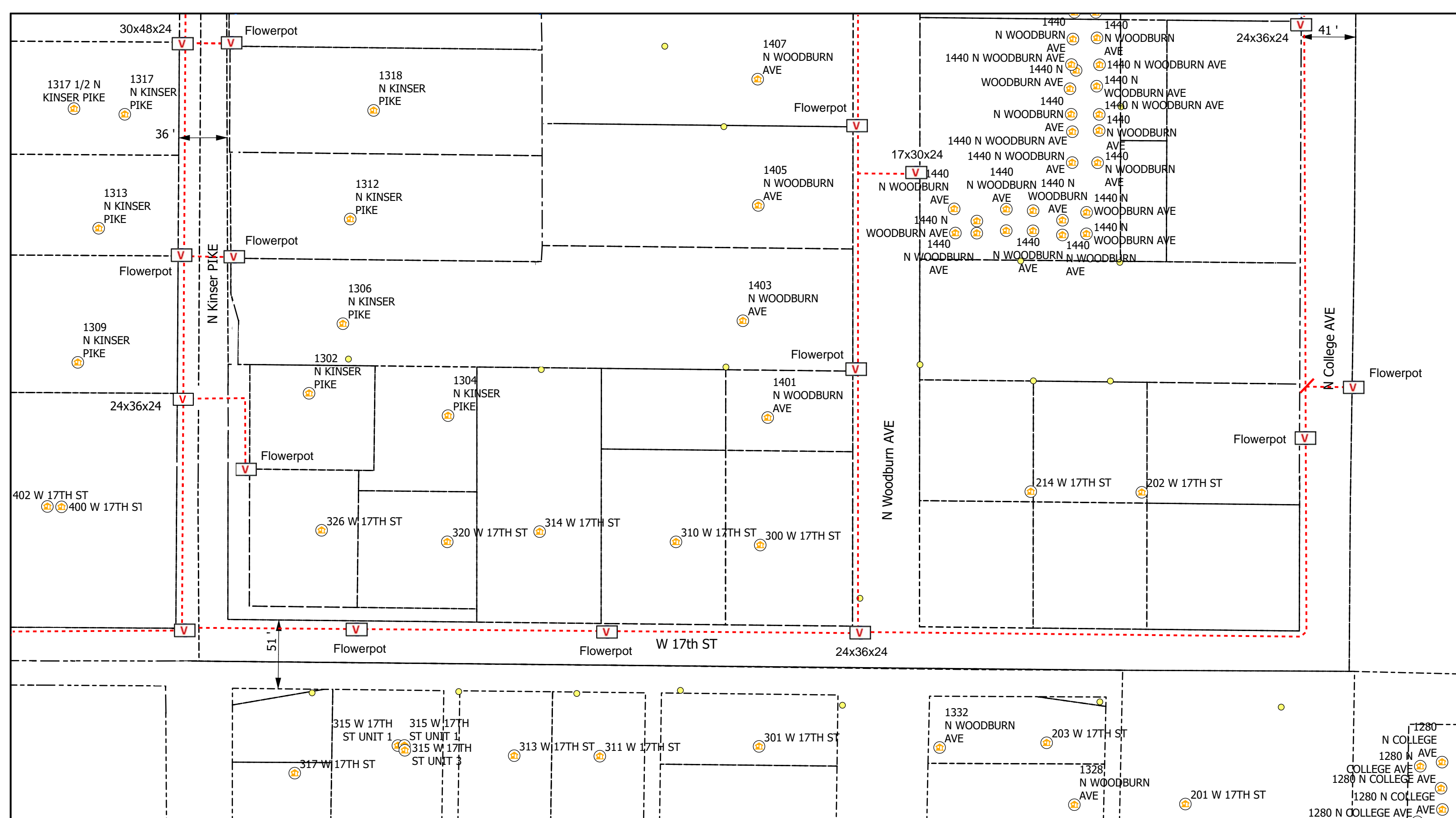

Legend

- Poles
- V Vaults
- Overhead Strand
- Conduit
- Ⓢ Risers
- Ⓜ Address
- Y Anchor
- ↖ Sidewalk
- Bloomington_Parcels
- Grids

All Flowerpots 12" DIA



City of Bloomington, IN Permit:
Design View

INI	BY	DATE	DESCRIPTION



Carlton® PV-Mold® Nonmetallic Pole Riser System

Carlton PV-Mold is a nonmetallic pole riser system designed to protect communications power cable installed on poles.

Features:

- Meets or exceeds requirements outlined in the National Electric Safety Code (NESC).
- Designed in accordance with NEMA TC-19 specifications.
- Ultraviolet, cold temperature and corrosive atmosphere resistant.
- Schedule 40 wall meets Schedule 80 PVC conduit impact requirements per NEMA TC-19.
- No grounding required.
- Belled end fits over each added section or conduit.
- Flame retardant.
- Requires no maintenance.
- PV-Mold acts as an insulator against electrical shock.
- Interchangeable parts and accessories to match the needs of specific requirements.



Steel U-Guard requires grounding strapping and does not have belled ends.



PV-Mold has belled ends, flanged design and does not require grounding.

Flanged Overall Length 10 Feet, Including Bell

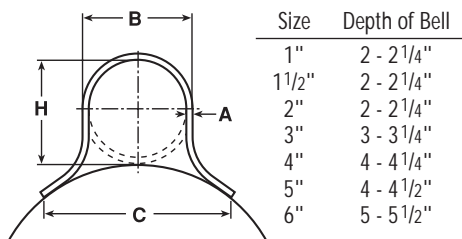

Slots are 1/2" from side to side, and allow for expansion and contraction.

Slot Dimensions: for sizes 2" through 6" are 5/16" wide, 3/4" long.

Slot Dimensions: for 1" and 1 1/2" are 3/16" wide, 3/4" long.

Slot Spacing: 18" from center, beginning 6" from end.

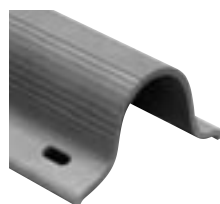

Standard Duty

Part No.	Size	Std. Ctn. Qty.	Std. Ctn. Wt. (lbs.)	Dimensions				Actual Impact @ 0°C 20 Pound Top
				A	B	C	H	
59208N	1"	294	1059	0.100"	1 5/8"	2 3/8"	1 5/8"	40 Ft.-Lbs.
59211N	2"	136	726	0.100"	2 3/8"	4 1/2"	2 3/8"	100 Ft.-Lbs.
59211X (5' length)	2"	136	363	0.100"	2 3/8"	4 1/2"	2 3/8"	100 Ft.-Lbs.
59213N	3"	66	761	0.150"	3 1/2"	6"	3 1/2"	110 Ft.-Lbs.
59213X (5' length)	3"	66	381	0.150"	3 1/2"	6"	3 1/2"	100 Ft.-Lbs.
59215N	4"	65	910	0.150"	4 1/2"	6 1/2"	4 1/2"	110 Ft.-Lbs.
59216N	5"	30	515	0.150"	5 1/2"	7 1/2"	5 1/2"	110 Ft.-Lbs.

Heavy Duty Schedule 40

59010N	1 1/2"	200	1142	0.145"	1 29/32"	3 1/2"	1 29/32"	100 Ft.-Lbs.
59011N	2"	136	1214	0.154"	2 3/8"	4 1/2"	2 3/8"	150 Ft.-Lbs.
59013N	3"	66	937	0.216"	3 1/2"	6"	3 9/32"	150 Ft.-Lbs.
59015N	4"	65	1621	0.237"	4 1/2"	6 1/2"	4 1/2"	260 Ft.-Lbs.
59015X (5' length)	4"	65	707	0.237"	4 1/2"	6 1/2"	4 1/2"	260 Ft.-Lbs.
59016N	5"	30	870	0.258"	5 1/2"	7 1/2"	5 1/2"	260 Ft.-Lbs.
59017N	6"	30	1160	0.280"	6 5/8"	8 3/4"	6 5/8"	260 Ft.-Lbs.

Extra Heavy Duty Schedule 80

59411N	2"	136	1549	0.218"	2 3/8"	4 1/2"	2 3/8"	300 Ft.-Lbs.
59413N	3"	66	1495	0.030"	3 1/2"	6"	3 1/2"	525 Ft.-Lbs.

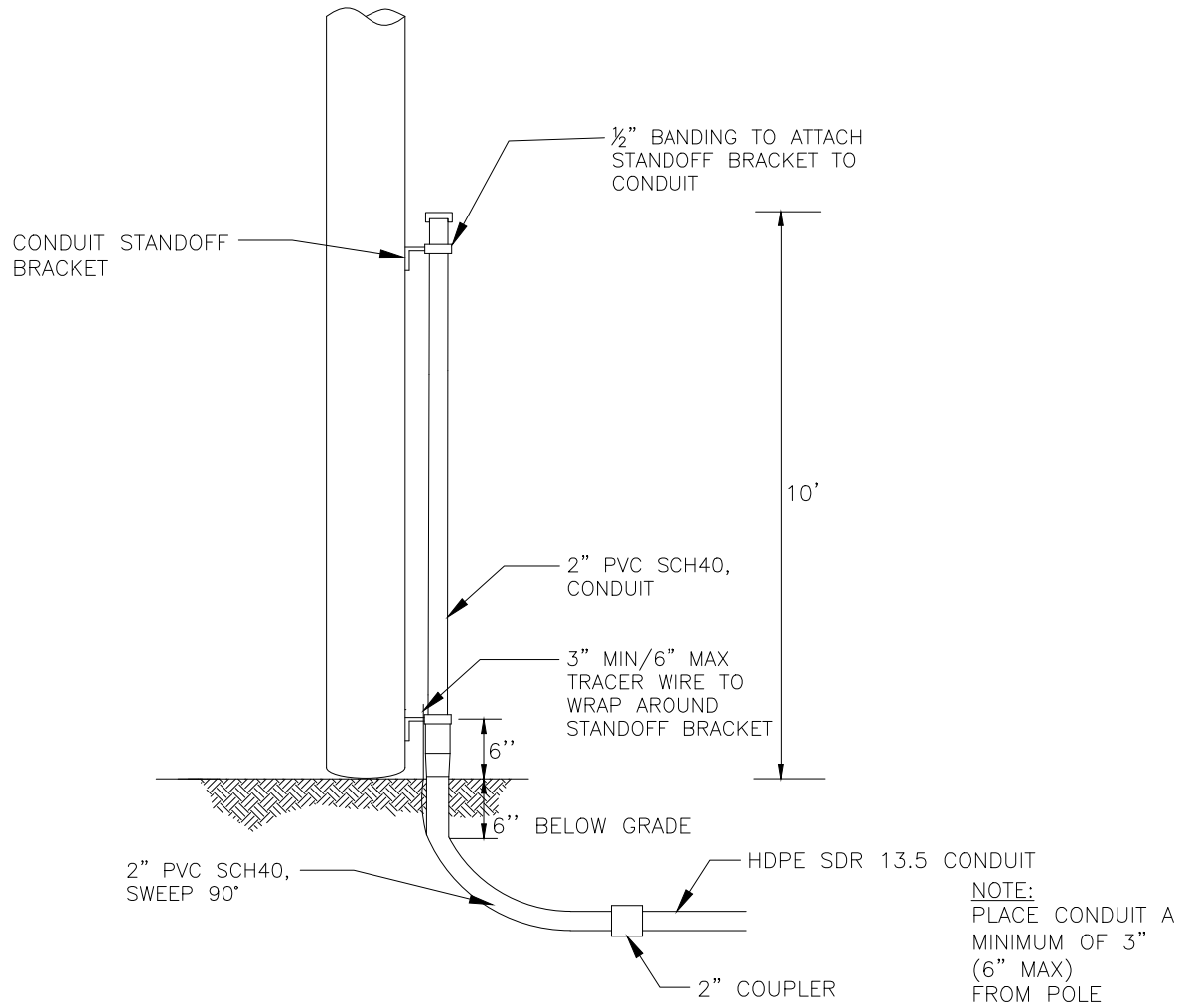

DESCRIPTION

QTY

MANUFACTURER
(PREFERRED)

PART #

SCREW, LAG, 1/2" x 4-1/2"	10		
HDPE SDR 13.5 CONDUIT, VARIOUS SIZES	N/A		
2" PVC SCH40, RISER PIPE	1		
#12 TRACER WIRE	N/A		
2" PVC SCH40, SWEEP, 90 DEG	1		
CONDUIT STANDOFF BRACKET	VARIES		
CONDUIT STRAP KIT	VARIES		
2" COUPLER	1		



TYPICAL RISER
CONDUIT
WOOD POLE

(R2-W)

CONCEPTUAL SIDE VIEW

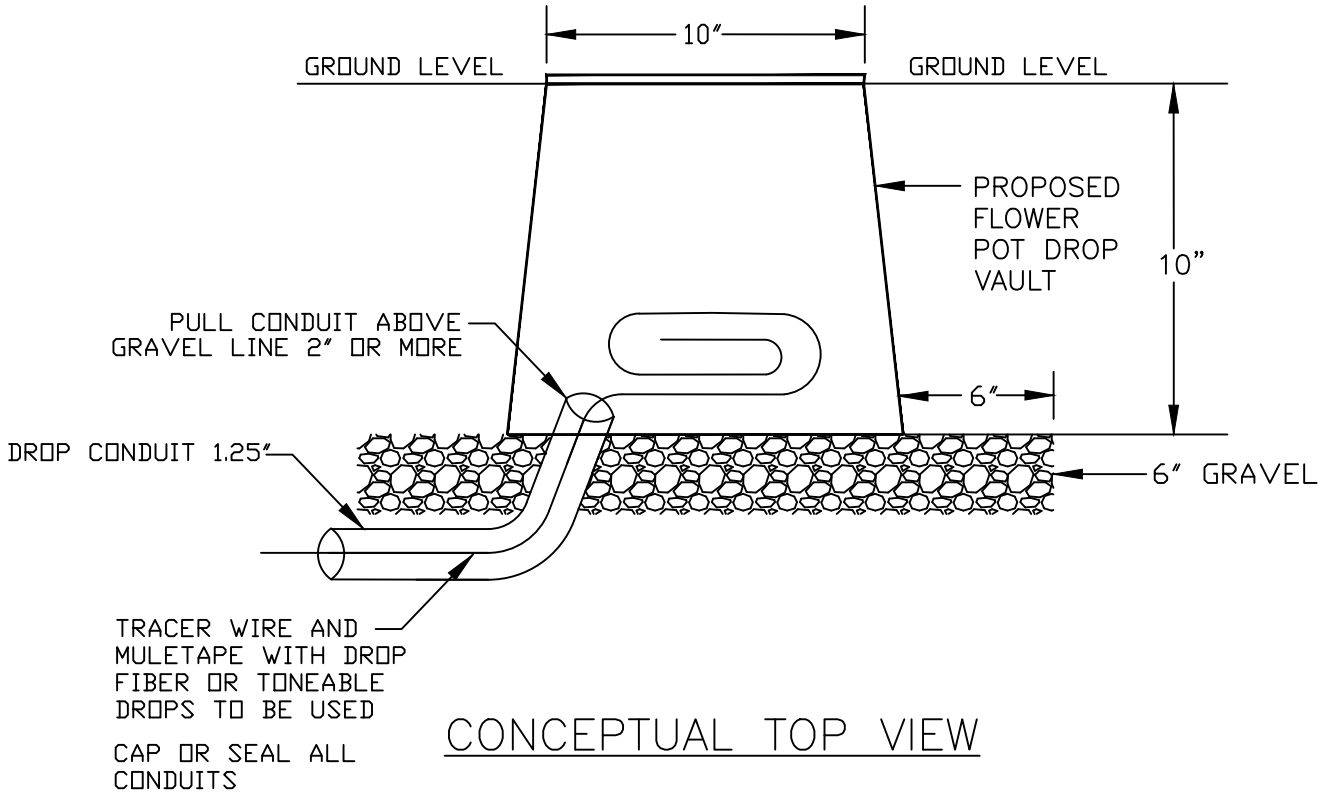

CONCEPTUAL TOP VIEW

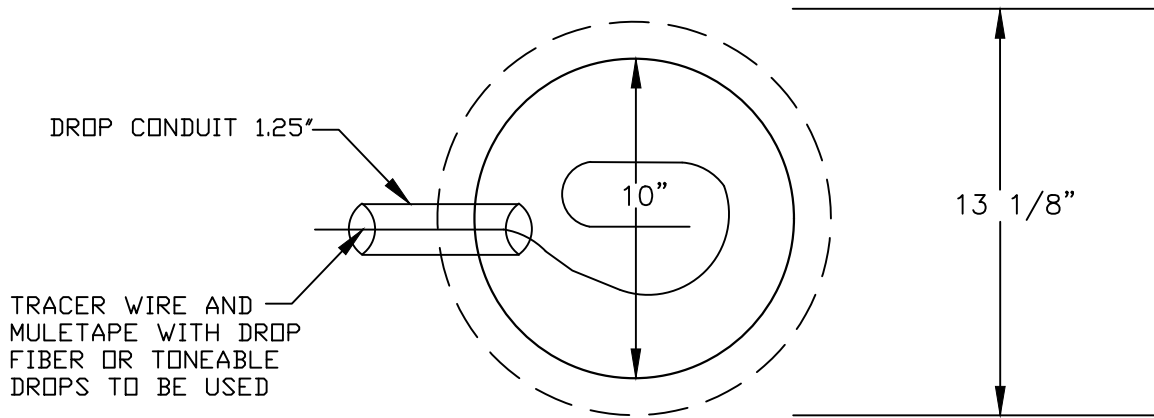

FLOWER POT

30"x48" PC UNIT, 2PC TIER 15/22
 18", 24", and 36" HEIGHT



AMERICAN POLYMER COMPANY

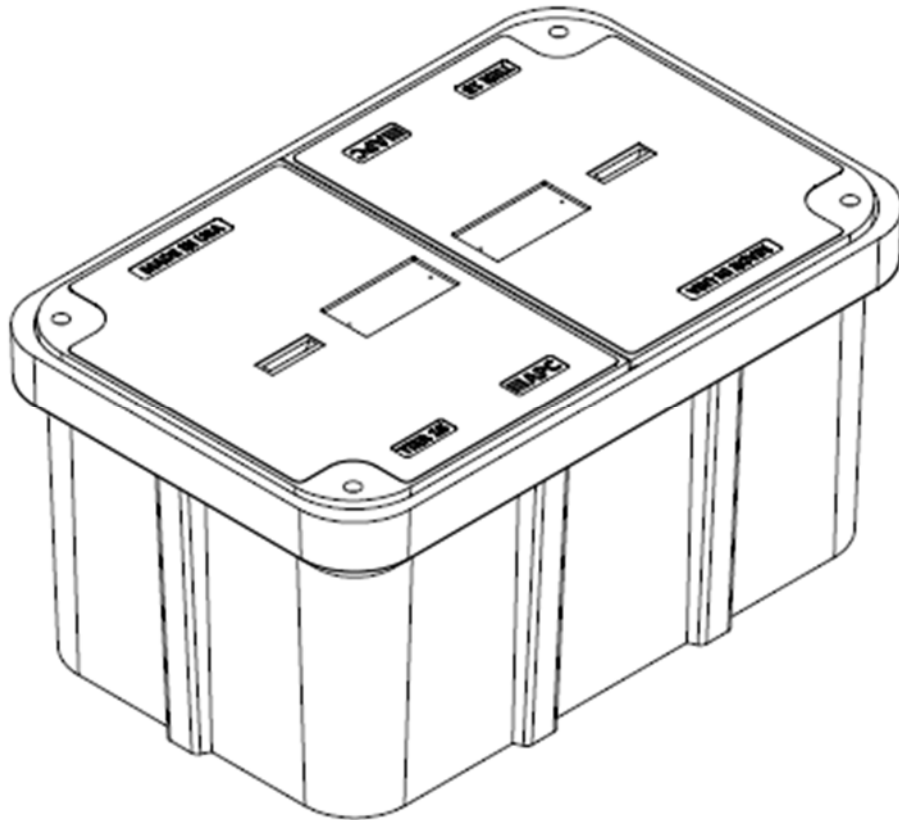

Description	Nominal Size	ANSI Tier	Part Number	Estimated Weight
PC Unit – TIER 15	30"x48"x18"	Tier 15	P304818HU15...	460 lbs.
PC Unit – TIER 22	30"x48"x18"	Tier 22	P304818HU22...	525 lbs.
PC Unit – TIER 15	30"x48"x24"	Tier 15	P304824HU15...	510 lbs.
PC Unit – TIER 22	30"x48"x24"	Tier 22	P304824HU22...	575 lbs.
PC Unit – TIER 15	30"x48"x36"	Tier 15	P304836HU15...	615 lbs.
PC Unit – TIER 22	30"x48"x36"	Tier 22	P304836HU22...	680 lbs.



30"x48" PC UNIT, 2PC TIER 15/22

18", 24", and 36" HEIGHT



AMERICAN POLYMER COMPANY

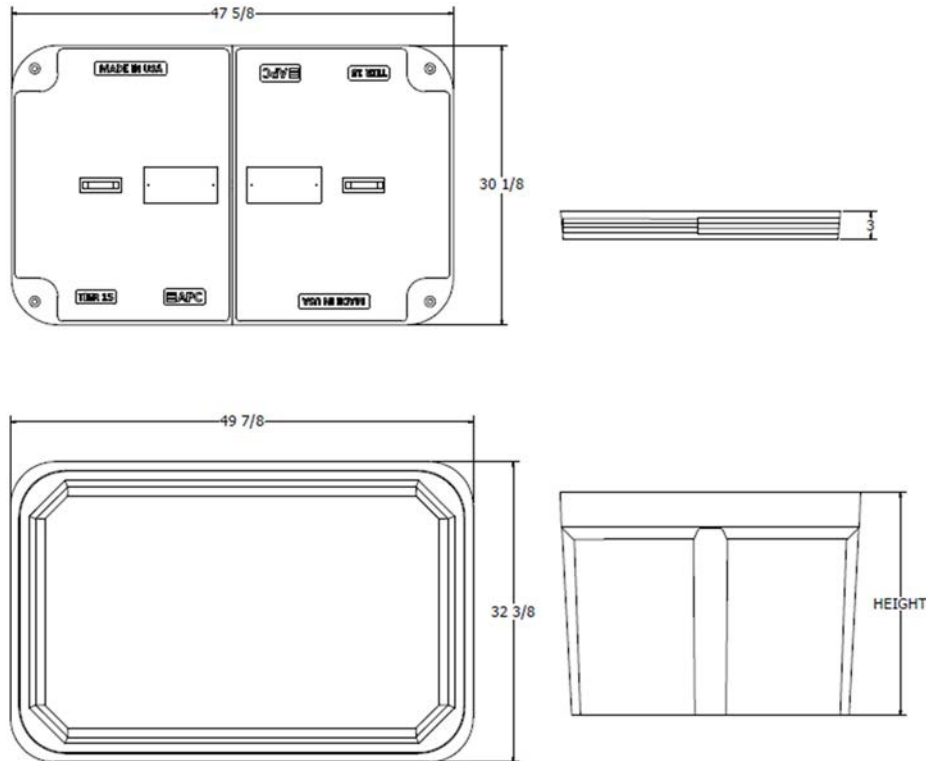

Components	Nominal Size	ANSI Tier	Part Number	Estimated Weight
Replacement Box	30"x48"x18"	Tier 22	P304818B22	185 lbs.
Replacement Box	30"x48"x24"	Tier 22	P304824B22	235 lbs.
Replacement Box	30"x48"x36"	Tier 22	P304836B22	340 lbs.
Replacement Lids - T15	30"x48" (half)	Tier 15	Various	150 lbs.
Replacement Lids - T22	30"x48" (half)	Tier 22	Various	170 lbs.

Bolt options



Machine Thread



Auger Thread



24"x36" PC UNIT, TIER 15/22
 18", 24", 30", and 36" HEIGHT



AMERICAN POLYMER COMPANY

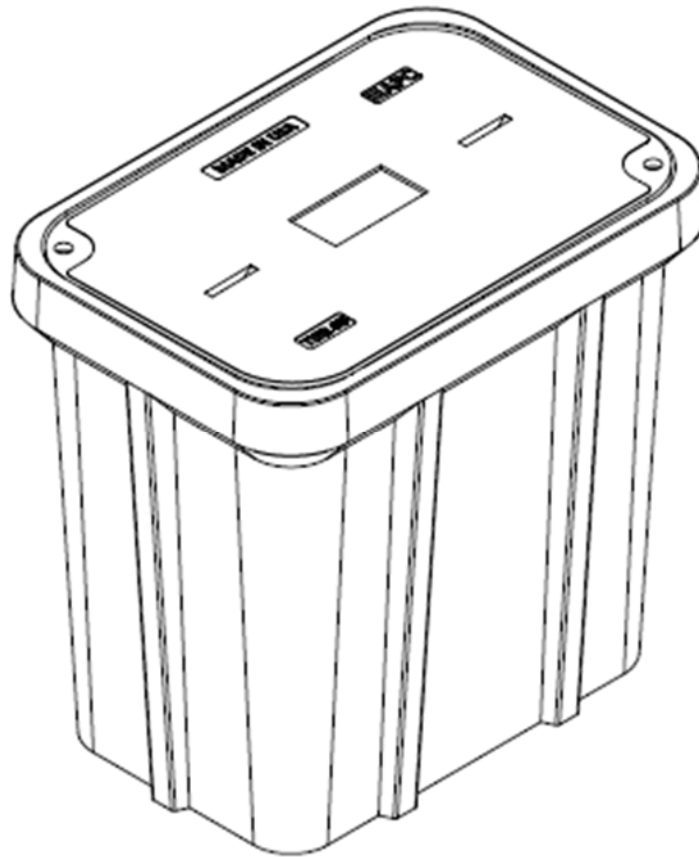

Description	Nominal Size	ANSI Tier	Part Number	Estimated Weight
PC Unit – TIER 15	24x36"x18"	Tier 15	P243618U15...	335 lbs.
PC Unit – TIER 22	24x36"x18"	Tier 22	P243618U22...	355 lbs.
PC Unit – TIER 15	24x36"x24"	Tier 15	P243624U15...	365 lbs.
PC Unit – TIER 22	24x36"x24"	Tier 22	P243624U22...	385 lbs.
PC Unit – TIER 15	24x36"x30"	Tier 15	P243630U15...	395 lbs.
PC Unit – TIER 22	24x36"x30"	Tier 22	P243630U22...	415 lbs.
PC Unit – TIER 15	24x36"x36"	Tier 15	P243636U15...	425 lbs.
PC Unit – TIER 22	24x36"x36"	Tier 22	P243636U22...	445 lbs.



24"x36" PC UNIT, TIER 15/22

18", 24", 30", and 36" HEIGHT



AMERICAN POLYMER COMPANY

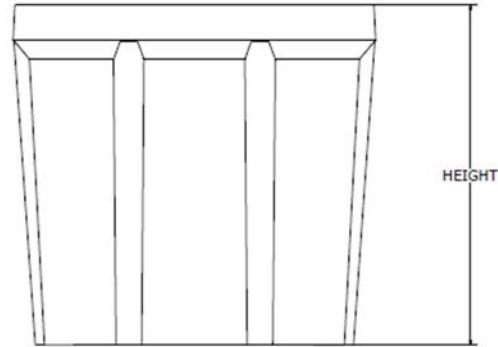
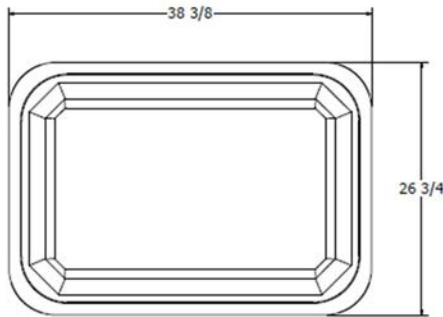
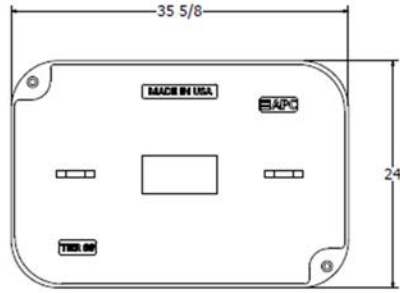

Components	Nominal Size	ANSI Tier	Part Number	Estimated Weight
Replacement Box	24"x36"x18"	Tier 22	P243618B22	165 lbs.
Replacement Box	24"x36"x24"	Tier 22	P243624B22	195 lbs.
Replacement Box	24"x36"x30"	Tier 22	P243630B22	225 lbs.
Replacement Box	24"x36"x36"	Tier 22	P243636B22	255 lbs.
Replacement Lids - T15	24"x36"	Tier 15	Various	170 lbs.
Replacement Lids - T22	24"x36"	Tier 22	Various	190 lbs.

Bolt options

Hex Head



Machine Thread



Penta Head



Auger Thread



17"x30" PC UNIT, TIER 15/22

12", 18", 24", and 30" HEIGHT



AMERICAN POLYMER COMPANY

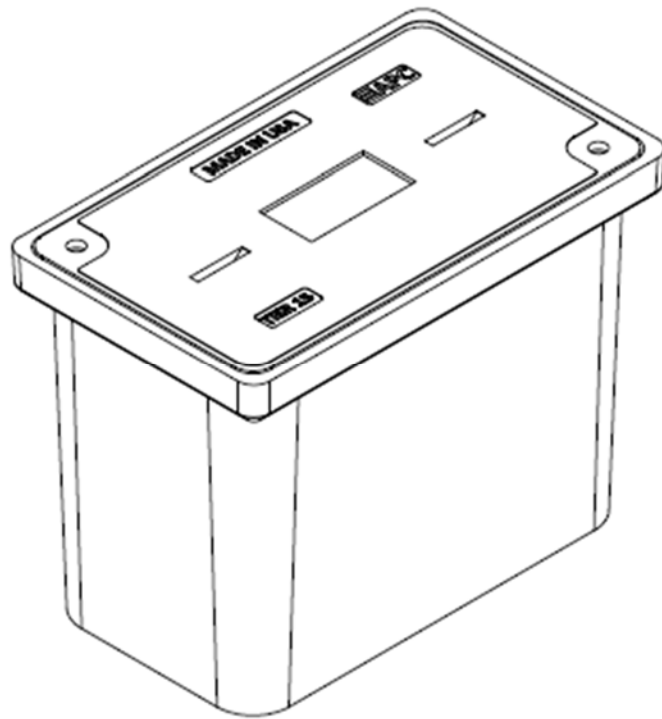

Description	Nominal Size	ANSI Tier	Part Number	Estimated Weight
PC Unit - TIER 15	17"x30"x12"	Tier 15	P173012U15...	138 lbs.
PC Unit - TIER 22	17"x30"x12"	Tier 22	P173012U22...	147 lbs.
PC Unit - TIER 15	17"x30"x18"	Tier 15	P173018U15...	172 lbs.
PC Unit - TIER 22	17"x30"x18"	Tier 22	P173018U22...	181 lbs.
PC Unit - TIER 15	17"x30"x24"	Tier 15	P173024U15...	192 lbs.
PC Unit - TIER 22	17"x30"x24"	Tier 22	P173024U22...	201 lbs.
PC Unit - TIER 15	17"x30"x30"	Tier 15	P173030U15...	217 lbs.
PC Unit - TIER 22	17"x30"x30"	Tier 22	P173030U22...	226 lbs.



17"x30" PC UNIT, TIER 15/22

12", 18", 24", and 30" HEIGHT



AMERICAN POLYMER COMPANY

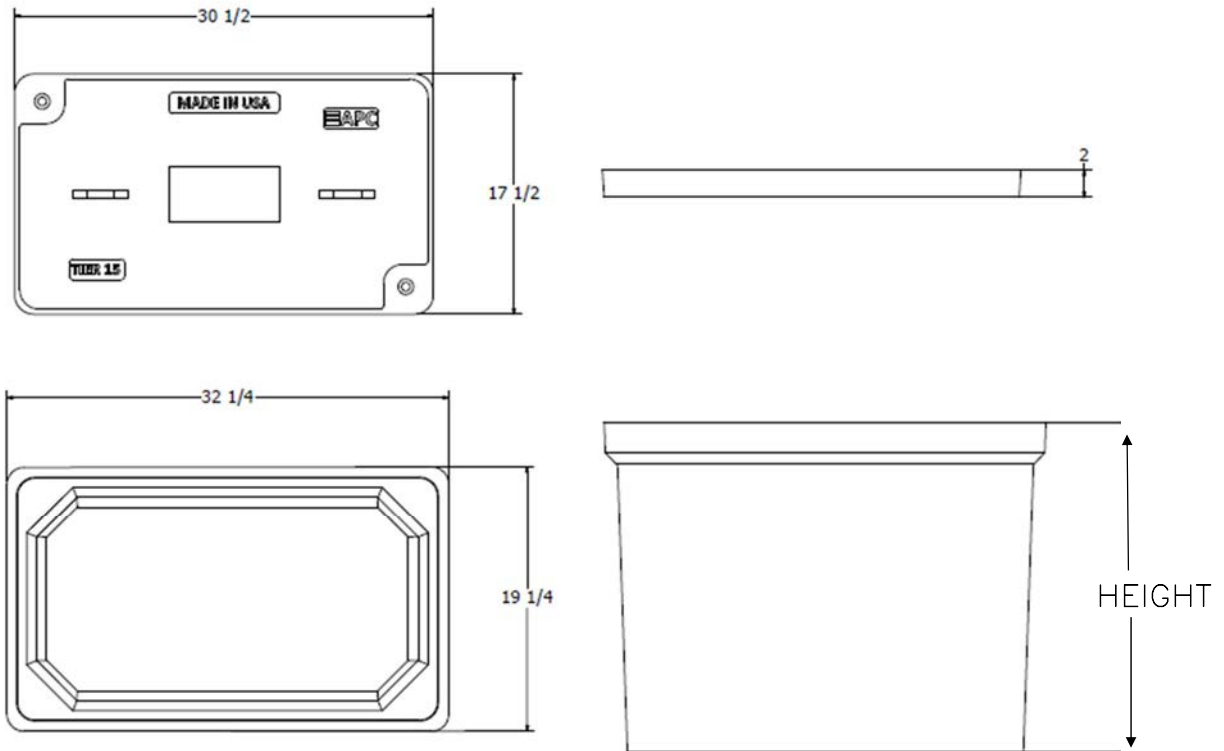

Components	Nominal Size	ANSI Tier	Part Number	Estimated Weight
Replacement Box	17"x30"x12"	Tier 22	P173012B22	66 lbs.
Replacement Box	17"x30"x18"	Tier 22	P173018B22	100 lbs.
Replacement Box	17"x30"x24"	Tier 22	P173024B22	120 lbs.
Replacement Box	17"x30"x30"	Tier 22	P173030B22	145 lbs.
Replacement Lids - T15	17"x30"	Tier 15	Various	72 lbs.
Replacement Lids - T22	17"x30"	Tier 22	Various	81 lbs.

Bolt options



Machine Thread



Auger Thread



33"x60" PC UNIT, 2PC TIER 15/22
36" HEIGHT



AMERICAN POLYMER COMPANY

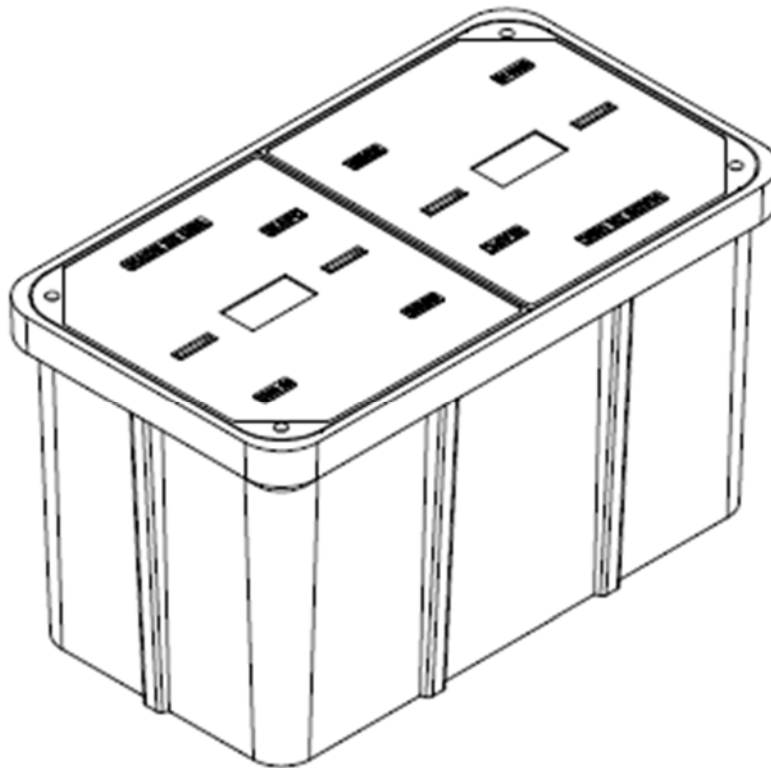

Description	Nominal Size	ANSI Tier	Part Number	Estimated Weight
PC Unit - TIER 15	33"x60"x36"	Tier 15	P336036U15...	930 lbs.
PC Unit - TIER 22	33"x60"x36"	Tier 22	P336036U22...	1030 lbs.



33"x60" PC UNIT, 2PC TIER 15/22

36" HEIGHT



AMERICAN POLYMER COMPANY

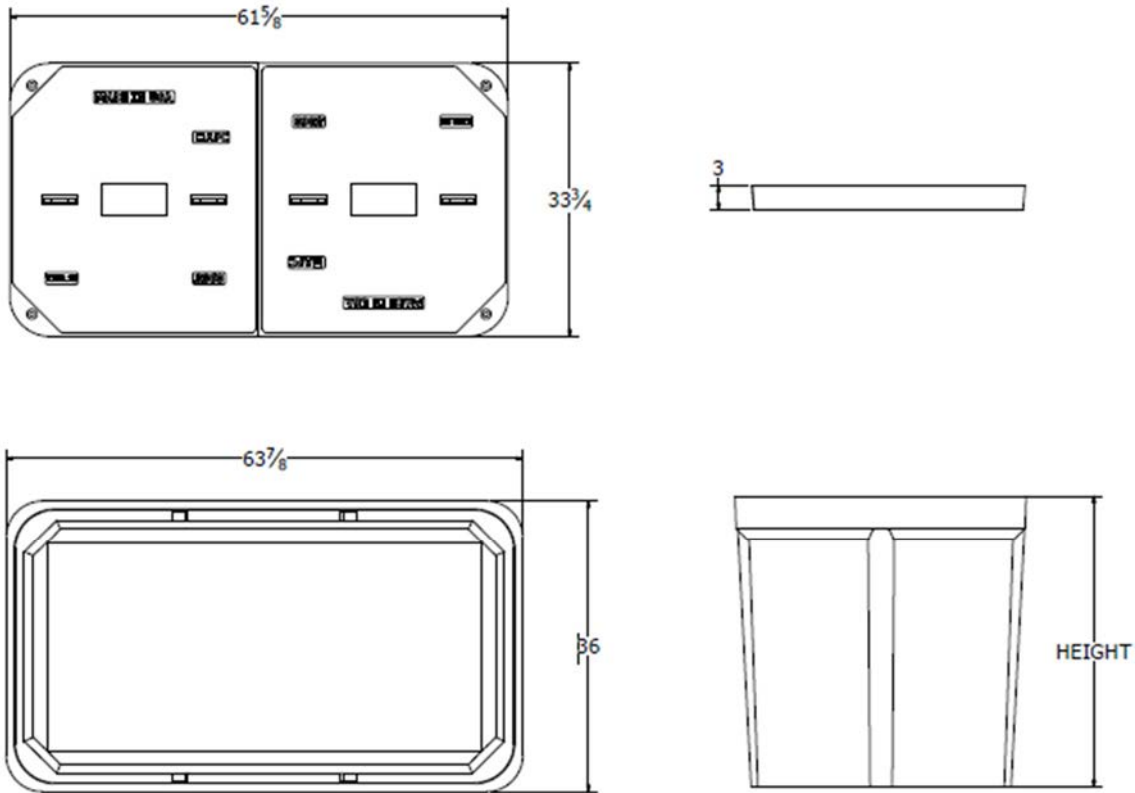

Components	Nominal Size	ANSI Tier	Part Number	Estimated Weight
Replacement Box	33"x60"x36"	Tier 22	P336036B22	530 lbs.
Replacement Lids - T15	33"x60" (half)	Tier 15	Various	200 lbs.
Replacement Lids - T22	33"x60" (half)	Tier 22	Various	250 lbs.

Bolt options

Hex Head



Machine Thread



Penta Head



Auger Thread



Spacing Charts Based on MUTCD			Must be Approved by an Engineer				
Speed (MPH) Prior To Road Work	SIGN SPACING, FT.		BUFFER SPACE, FT.	TAPER LENGTH, FT.		CHANNELIZING SPACING, FT.	
	Non-Divided Highways	Divided Highways		Shoulder (10 ft Width)	Lane (12 ft Width)	Through Taper	Through Buffer/Work Area
0-35	200	200	250	70	245	35	50
40-45	350	500	360	150	540	40	80
50-55	500	1000	495	185	660	50	100
60-70	SA-1000, SB-1500, SC-2640		730	235	840	60	120
	Urban Low Speed - 100 FT						

APPROVED/ACCEPTED BY:
ENGINEER, OWNER, or PRIME CONTRACTOR

Check for Notice to Proceed.

Signature: _____

Company: _____

Date: 11/17/2023 **Project:** BLN01a-F06 Hoosier Court Ave TCP1a :
: **Traffic Control Suggestion For:** ATLANTIC ENGINEERING (AEG) :
By: Road Runner Safety Services, Inc. : Nathan

Comments:
Drawing not to scale. Traffic control plan must be approved by an engineer. This is a suggestion only. Road Runners Safety Services, Inc. has no liability for this suggested traffic control plan. Actual placement and spacing of all traffic control devices will depend on field conditions and must conform to MUTCD standards.



Google Earth

Spacing Charts Based on MUTCD Must be Approved by an Engineer

Speed (MPH) Prior To Road Work	SIGN SPACING, FT.		BUFFER SPACE, FT.	TAPER LENGTH, FT.		CHANNELIZING SPACING, FT.	
	Non-Divided Highways	Divided Highways	Length	Shoulder (10 ft Width)	Lane (12 ft Width)	Through Taper	Through Buffer/Work Area
0-35	200	200	250	70	245	35	50
40-45	350	500	360	150	540	40	80
50-55	500	1000	495	185	660	50	100
60-70	SA-1000, SB-1500, SC-2640		730	235	840	60	120
Urban Low Speed - 100 FT							

APPROVED/ACCEPTED BY:
ENGINEER, OWNER, or PRIME CONTRACTOR
 Check for Notice to Proceed.

Signature: _____
Company: _____



Date: 11/17/2023 Project: BLN01a-F06_Hoosier Court Ave TCP2 :
: Traffic Control Suggestion For: ATLANTIC ENGINEERING (AEG) :
By: Road Runner Safety Services, Inc. : Nathan

Comments:
Drawing not to scale. Traffic control plan must be approved by an engineer. This is a suggestion only. Road Runners Safety Services, Inc. has no liability for this suggested traffic control plan. Actual placement and spacing of all traffic control devices will depend on field conditions and must conform to MUTCD standards.

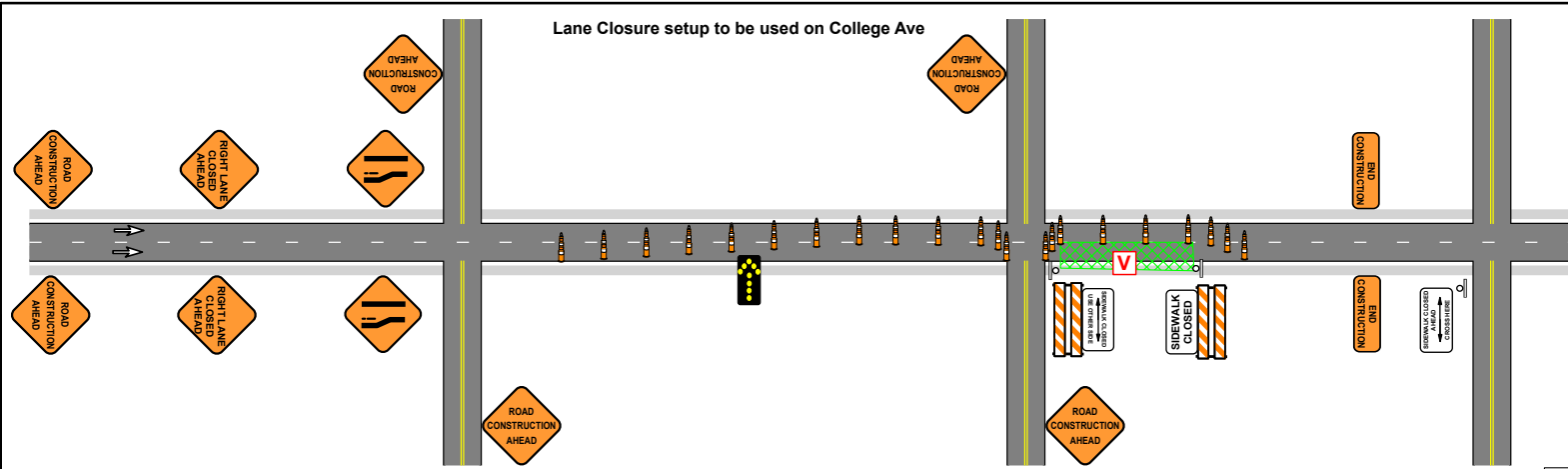

Road Construction Ahead signs to be placed on all side streets within work area.
Sidewalk Closed Ahead Cross Here signs to be placed at nearest crossing.

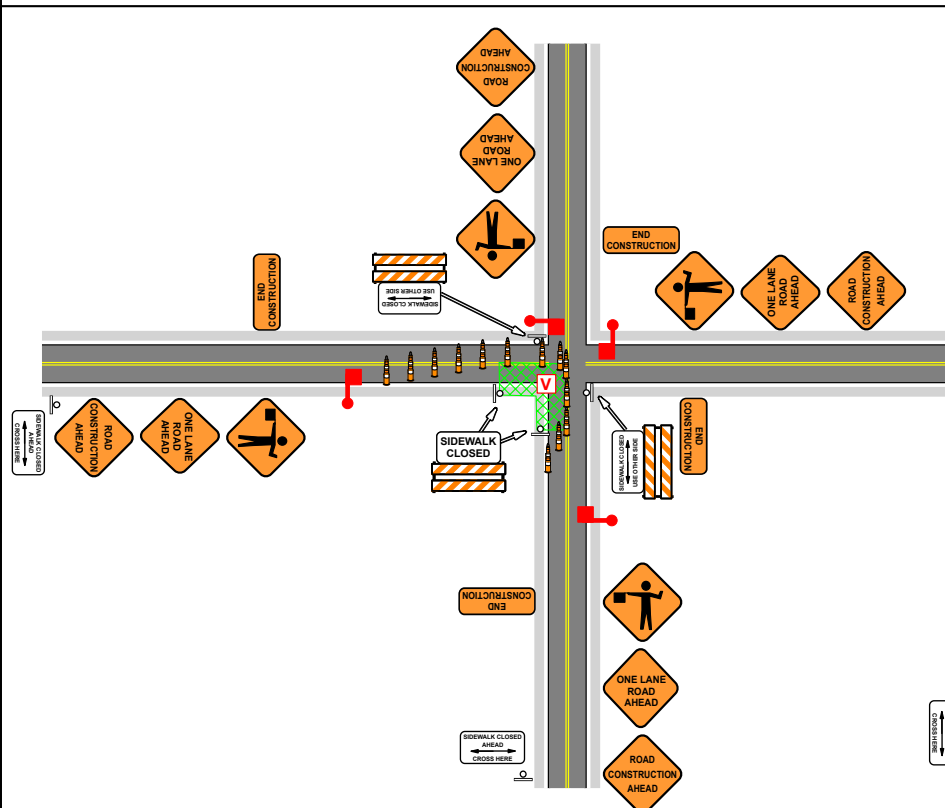

Flagger Setups to be used on residential 2 way streets.

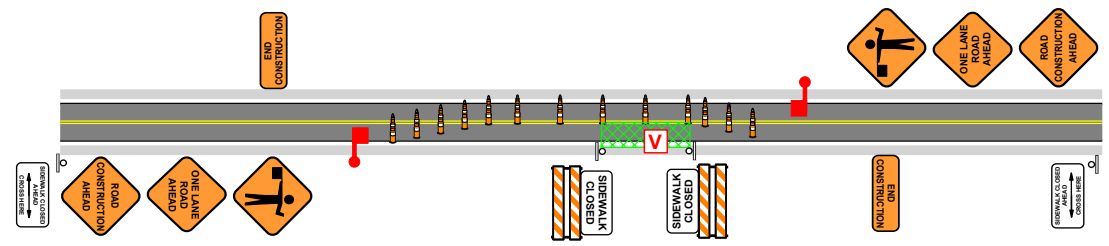

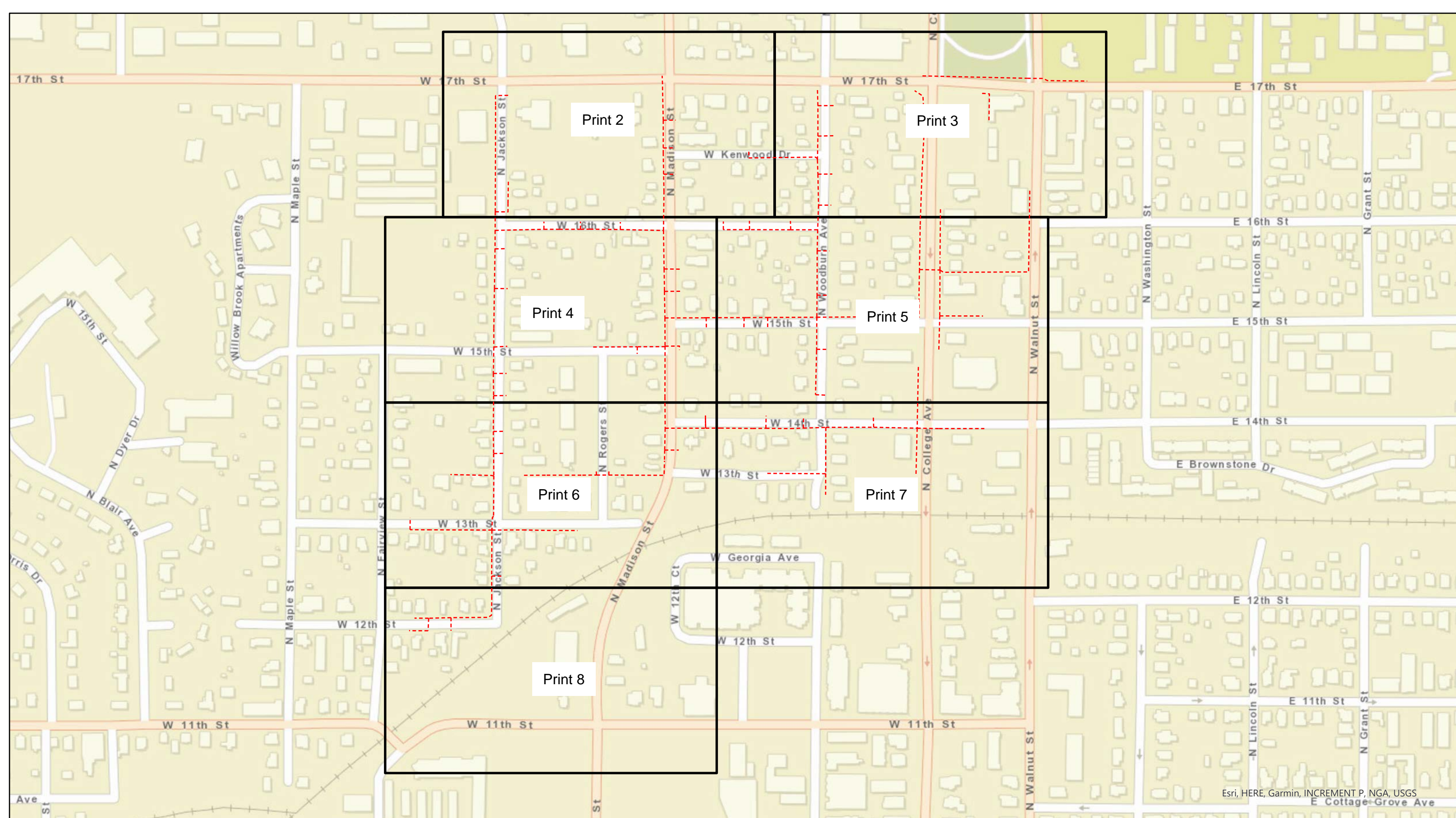

Esri, HERE, Garmin, INCREMENT P, NGA, USGS
E Cottage Grove Ave



Legend BL24 - E 16th St

- Overhead Strand
- - - Conduit
- Grids



City of Bloomington, IN Permit:
Design View

INI	BY	DATE	DESCRIPTION

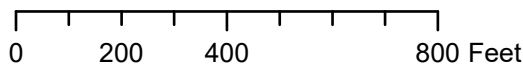

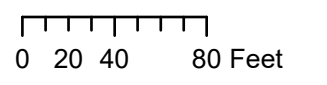
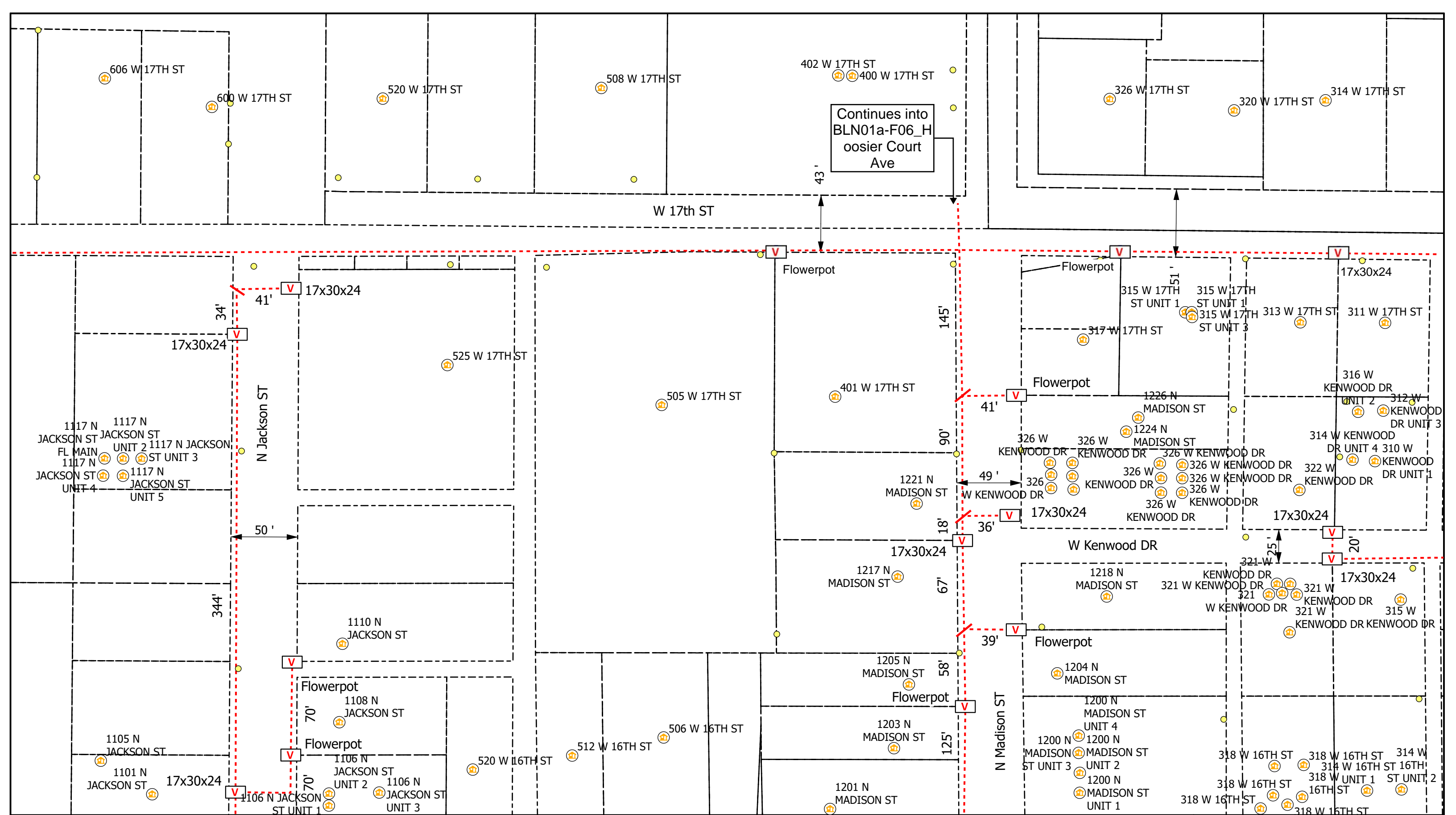

Legend

- Poles
- Ⓡ Risers
- ↖ Sidewalk
- V Vaults
- Overhead Strand
- - - Conduit
- 🏠 Address
- Y Anchor
- Bloomington_Parcels
- Grids

All Flowerpots 12" DIA



City of Bloomington, IN Permit:
Design View

INI	BY	DATE	DESCRIPTION



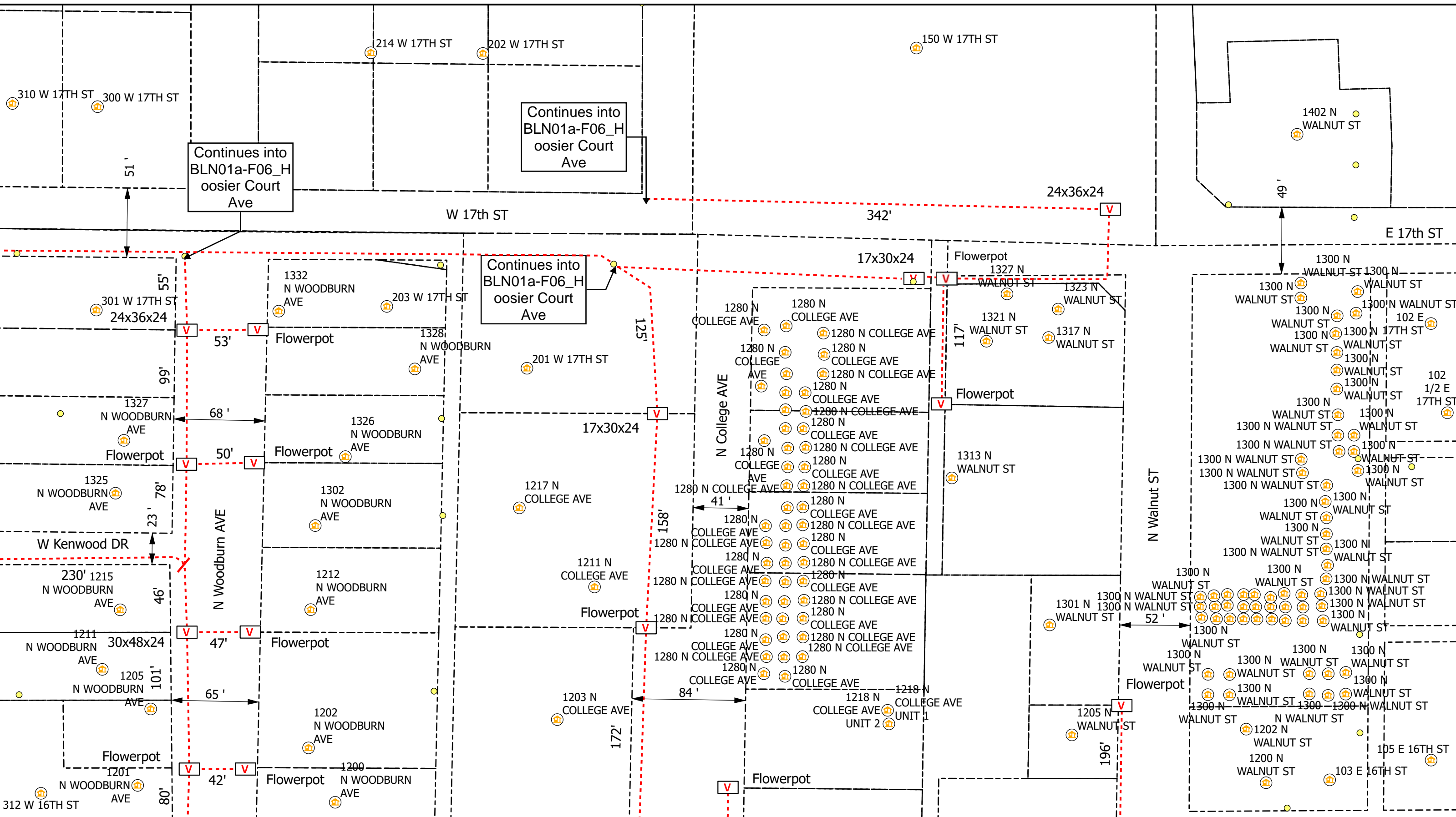

Legend

- Poles
- Risers
- Sidewalk
- Vaults
- Address
- Bloomington_Parcels
- Overhead Strand
- Anchor
- Grids
- Conduit

All Flowerpots 12" DIA

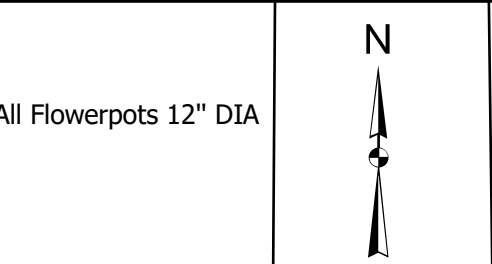

City of Bloomington, IN Permit:
Design View

INI	BY	DATE	DESCRIPTION

Print 3 of 8

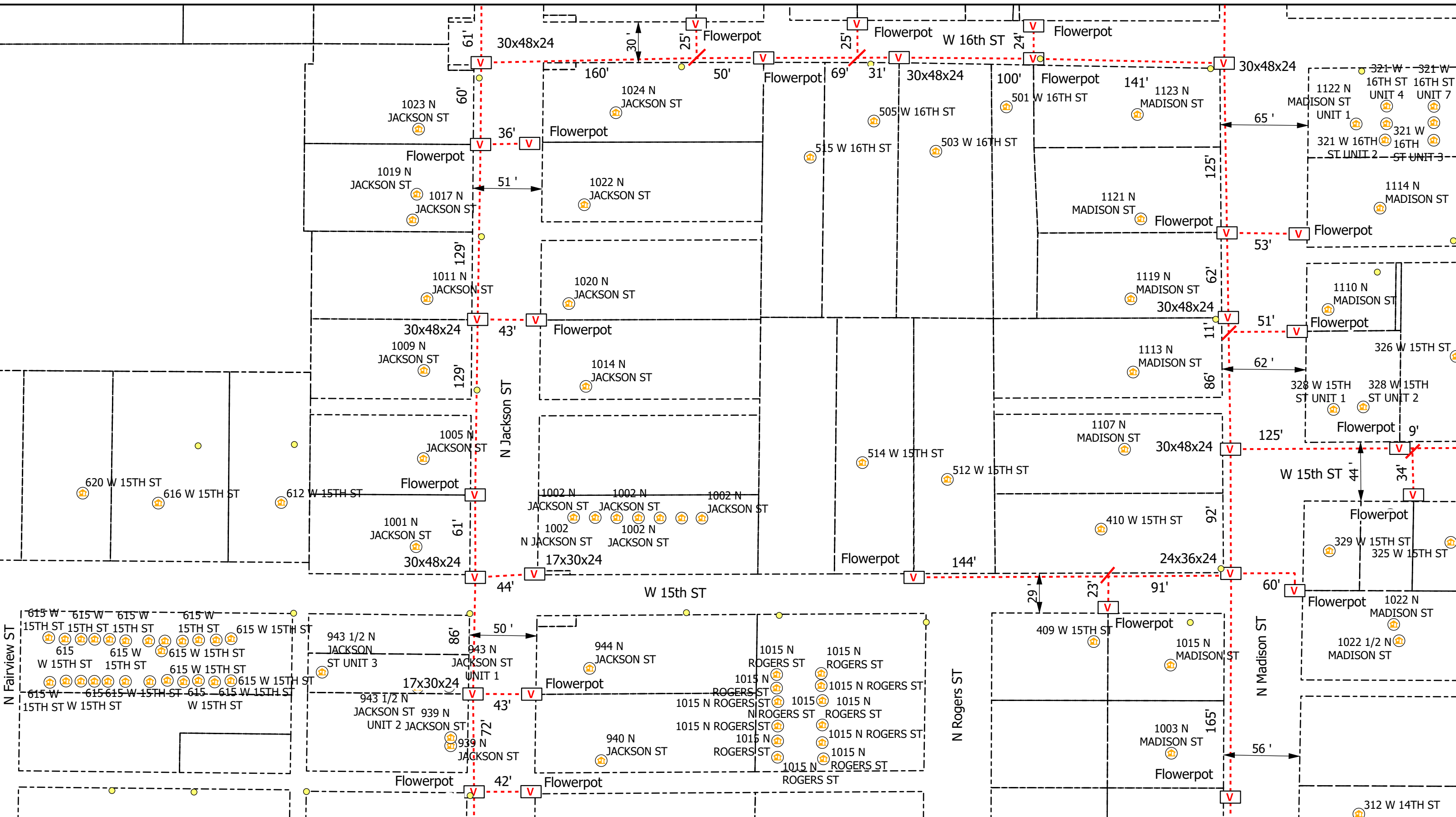

Legend

- Poles
- V Vaults
- Overhead Strand
- - - Conduit
- R Risers
- ⊙ Address
- Y Anchor
- └─┘ Sidewalk
- Bloomington_Parcels
- Grids

All Flowerpots 12" DIA

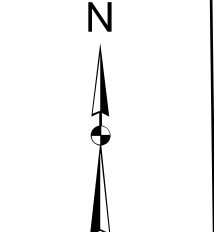

City of Bloomington, IN Permit:
Design View

INI	BY	DATE	DESCRIPTION



Print 4 of 8

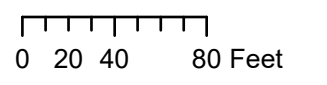
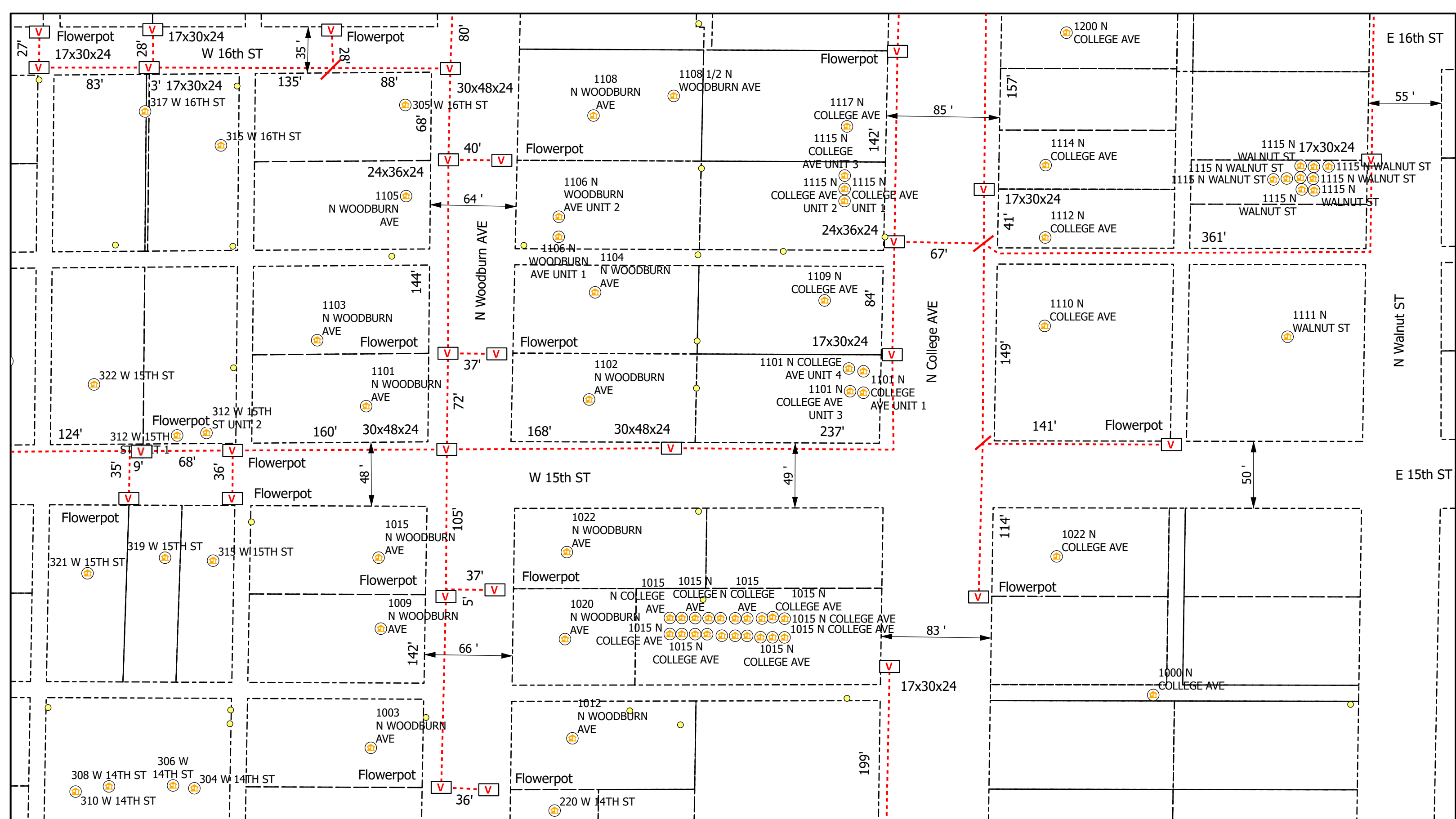

Legend

- Poles
- ⊕ Risers
- ⬆ Sidewalk
- V Vaults
- Overhead Strand
- Conduit
- Ⓜ Address
- Y Anchor
- Bloomington_Parcels
- Grids

All Flowerpots 12" DIA



City of Bloomington, IN Permit:
Design View

INI	BY	DATE	DESCRIPTION



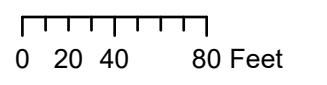
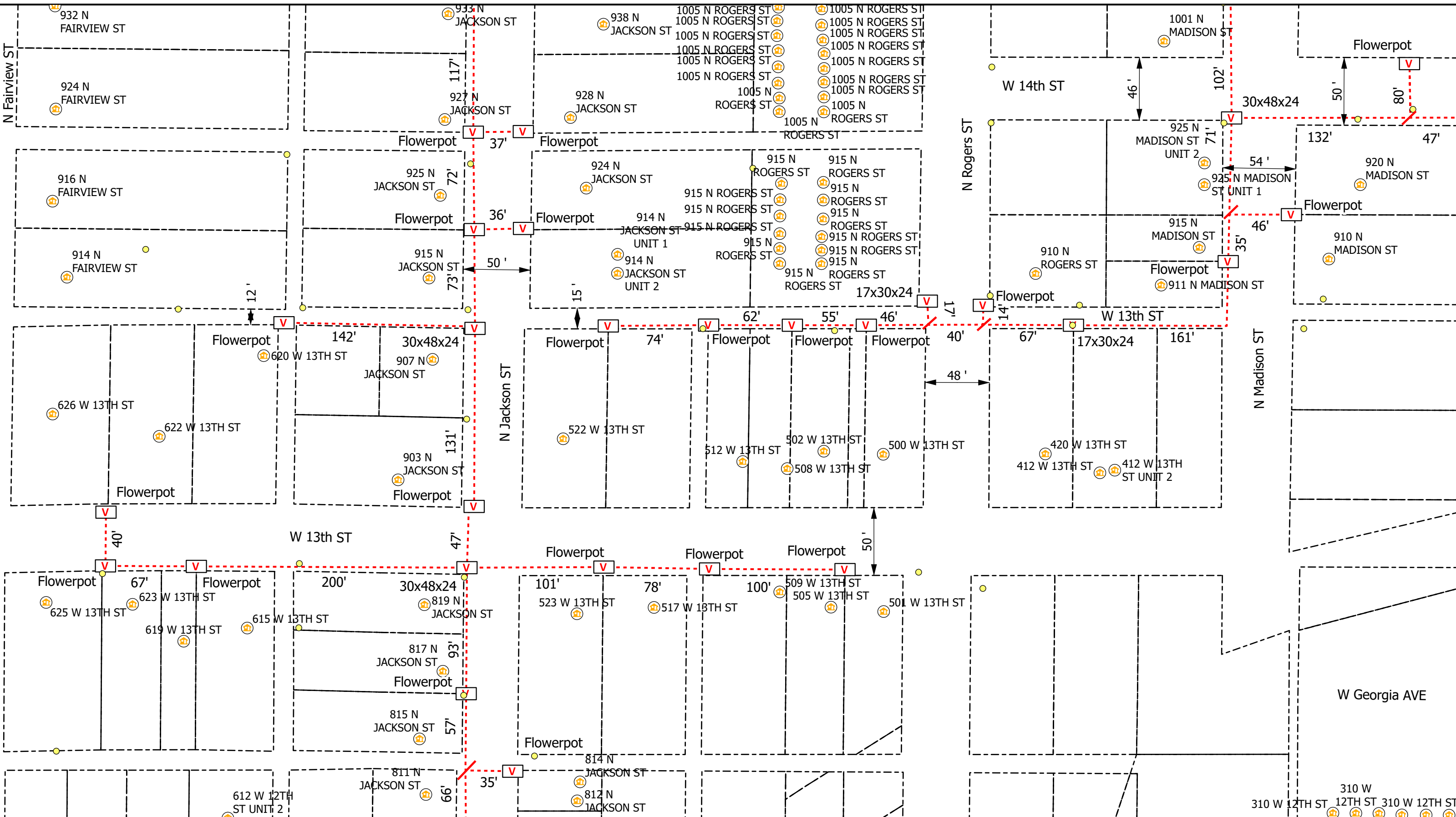

Legend

- Poles
- Vaults
- Overhead Strand
- Conduit
- Risers
- Address
- Anchor
- Sidewalk
- Bloomington_Parcels
- Grids

All Flowerpots 12" DIA



City of Bloomington, IN Permit:
Design View

INI	BY	DATE	DESCRIPTION



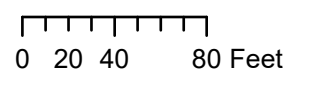
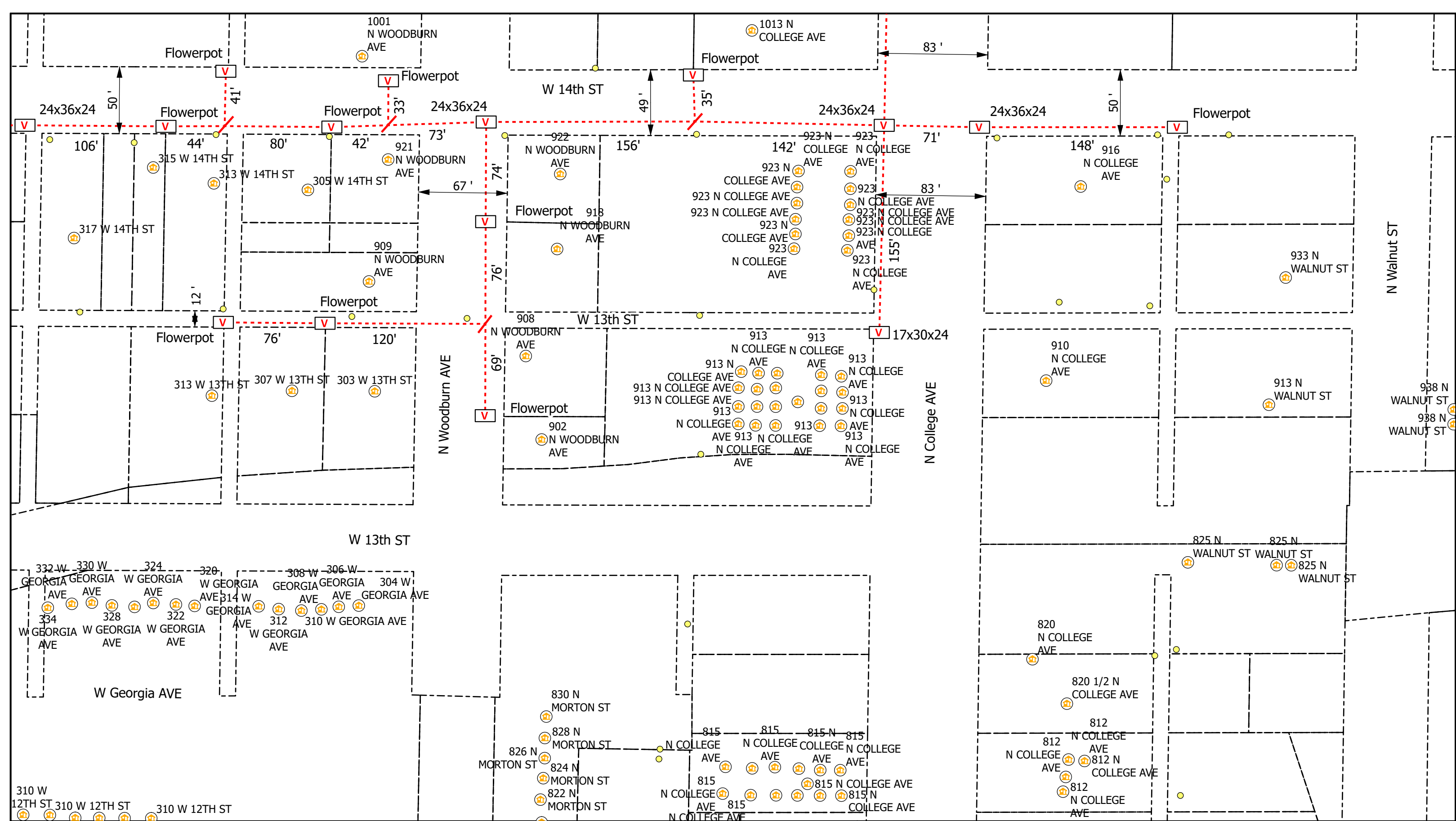

Legend

- Poles
- V Vaults
- Overhead Strand
- - - Conduit
- Ⓡ Risers
- Ⓜ Address
- Y Anchor
- ↖ Sidewalk
- Bloomington_Parcels
- Grids

All Flowerpots 12" DIA



City of Bloomington, IN Permit:
Design View

INI	BY	DATE	DESCRIPTION



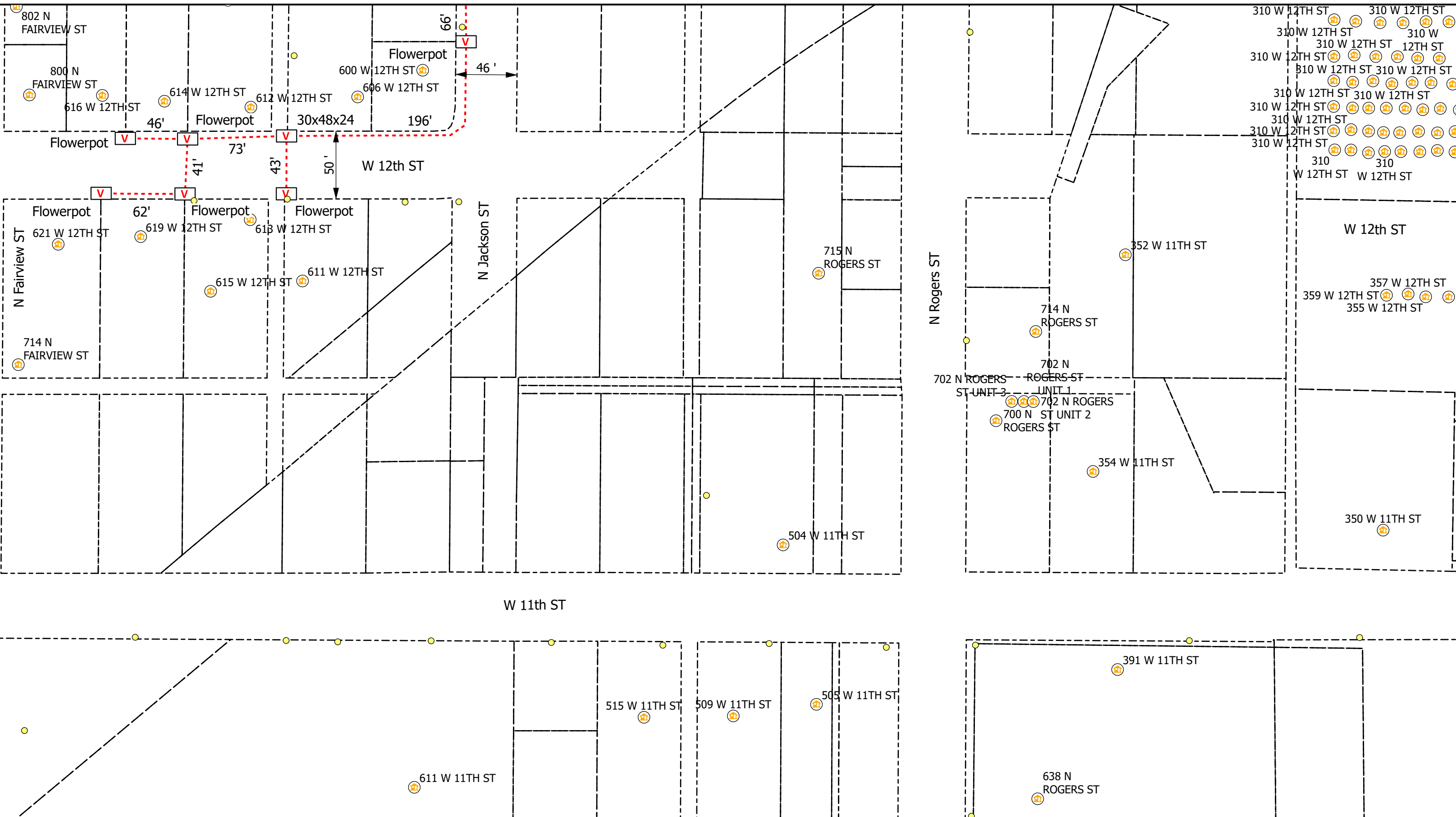

- Legend**
- Poles
 - Risers
 - Sidewalk
 - Vaults
 - Address
 - Bloomington_Parcels
 - Overhead Strand
 - Anchor
 - Conduit
 - Grids

All Flowerpots 12" DIA



City of Bloomington, IN Permit:
Design View

INI	BY	DATE	DESCRIPTION



Carlton® PV-Mold® Nonmetallic Pole Riser System

Carlton PV-Mold is a nonmetallic pole riser system designed to protect communications power cable installed on poles.

Features:

- Meets or exceeds requirements outlined in the National Electric Safety Code (NESC).
- Designed in accordance with NEMA TC-19 specifications.
- Ultraviolet, cold temperature and corrosive atmosphere resistant.
- Schedule 40 wall meets Schedule 80 PVC conduit impact requirements per NEMA TC-19.
- No grounding required.
- Belled end fits over each added section or conduit.
- Flame retardant.
- Requires no maintenance.
- PV-Mold acts as an insulator against electrical shock.
- Interchangeable parts and accessories to match the needs of specific requirements.



Steel U-Guard requires grounding strapping and does not have belled ends.



PV-Mold has belled ends, flanged design and does not require grounding.

Flanged Overall Length 10 Feet, Including Bell

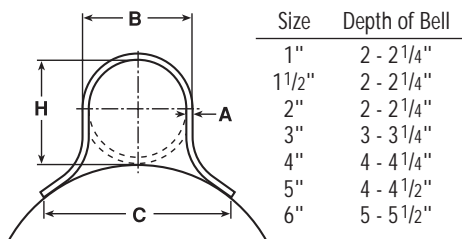

Slots are 1/2" from side to side, and allow for expansion and contraction.

Slot Dimensions: for sizes 2" through 6" are 5/16" wide, 3/4" long.

Slot Dimensions: for 1" and 1 1/2" are 3/16" wide, 3/4" long.

Slot Spacing: 18" from center, beginning 6" from end.

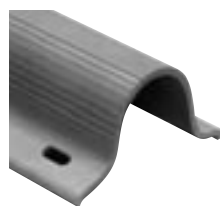

Standard Duty

Part No.	Size	Std. Ctn. Qty.	Std. Ctn. Wt. (lbs.)	Dimensions				Actual Impact @ 0°C 20 Pound Top
				A	B	C	H	
59208N	1"	294	1059	0.100"	1 5/8"	2 3/8"	1 5/8"	40 Ft.-Lbs.
59211N	2"	136	726	0.100"	2 3/8"	4 1/2"	2 3/8"	100 Ft.-Lbs.
59211X (5' length)	2"	136	363	0.100"	2 3/8"	4 1/2"	2 3/8"	100 Ft.-Lbs.
59213N	3"	66	761	0.150"	3 1/2"	6"	3 1/2"	110 Ft.-Lbs.
59213X (5' length)	3"	66	381	0.150"	3 1/2"	6"	3 1/2"	100 Ft.-Lbs.
59215N	4"	65	910	0.150"	4 1/2"	6 1/2"	4 1/2"	110 Ft.-Lbs.
59216N	5"	30	515	0.150"	5 1/2"	7 1/2"	5 1/2"	110 Ft.-Lbs.

Heavy Duty Schedule 40

59010N	1 1/2"	200	1142	0.145"	1 29/32"	3 1/2"	1 29/32"	100 Ft.-Lbs.
59011N	2"	136	1214	0.154"	2 3/8"	4 1/2"	2 3/8"	150 Ft.-Lbs.
59013N	3"	66	937	0.216"	3 1/2"	6"	3 9/32"	150 Ft.-Lbs.
59015N	4"	65	1621	0.237"	4 1/2"	6 1/2"	4 1/2"	260 Ft.-Lbs.
59015X (5' length)	4"	65	707	0.237"	4 1/2"	6 1/2"	4 1/2"	260 Ft.-Lbs.
59016N	5"	30	870	0.258"	5 1/2"	7 1/2"	5 1/2"	260 Ft.-Lbs.
59017N	6"	30	1160	0.280"	6 5/8"	8 3/4"	6 5/8"	260 Ft.-Lbs.

Extra Heavy Duty Schedule 80

59411N	2"	136	1549	0.218"	2 3/8"	4 1/2"	2 3/8"	300 Ft.-Lbs.
59413N	3"	66	1495	0.030"	3 1/2"	6"	3 1/2"	525 Ft.-Lbs.

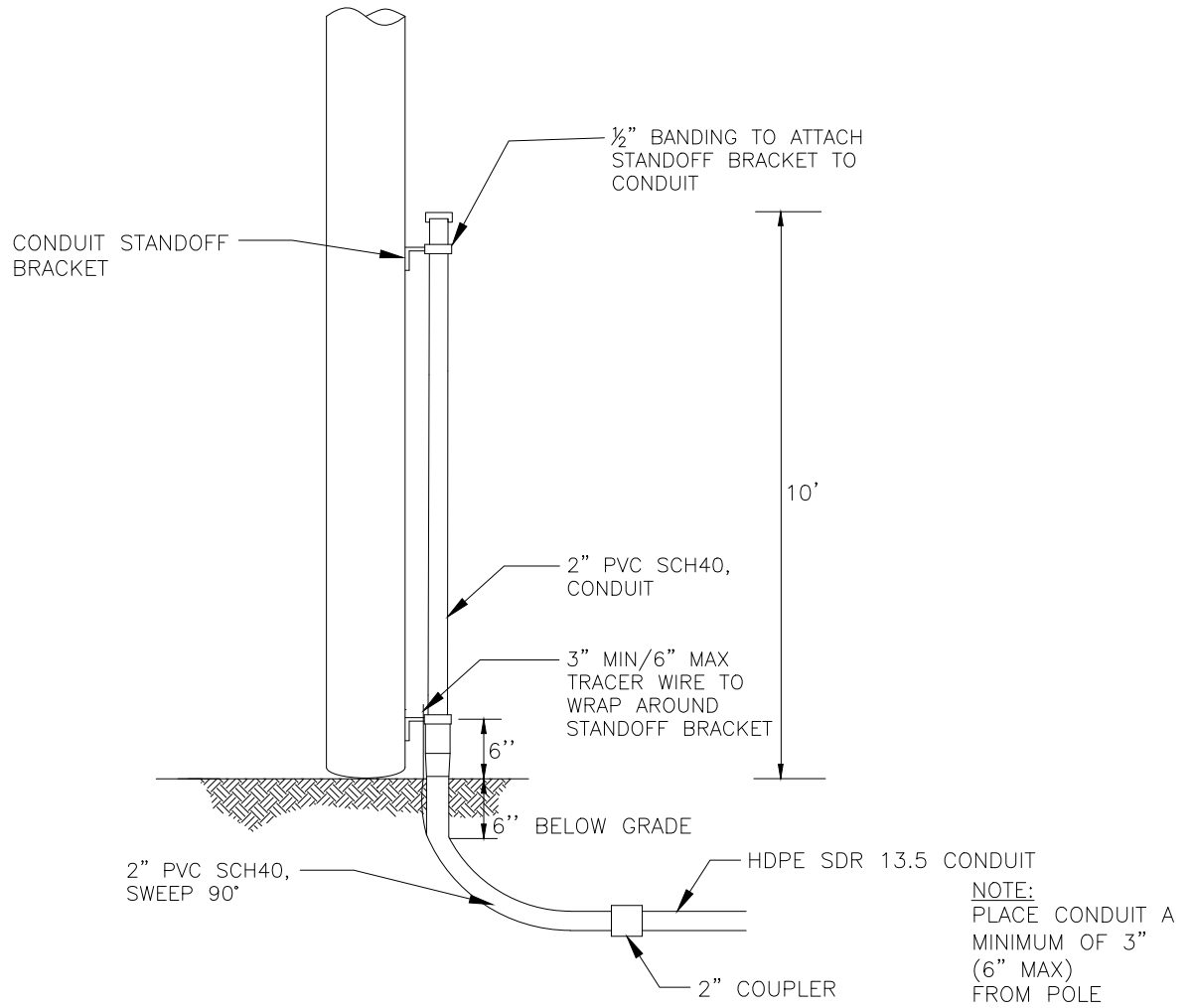

DESCRIPTION

QTY

MANUFACTURER
(PREFERRED)

PART #

SCREW, LAG, 1/2" x 4-1/2"	10		
HDPE SDR 13.5 CONDUIT, VARIOUS SIZES	N/A		
2" PVC SCH40, RISER PIPE	1		
#12 TRACER WIRE	N/A		
2" PVC SCH40, SWEEP, 90 DEG	1		
CONDUIT STANDOFF BRACKET	VARIES		
CONDUIT STRAP KIT	VARIES		
2" COUPLER	1		



TYPICAL RISER
CONDUIT
WOOD POLE

(R2-W)

CONCEPTUAL SIDE VIEW

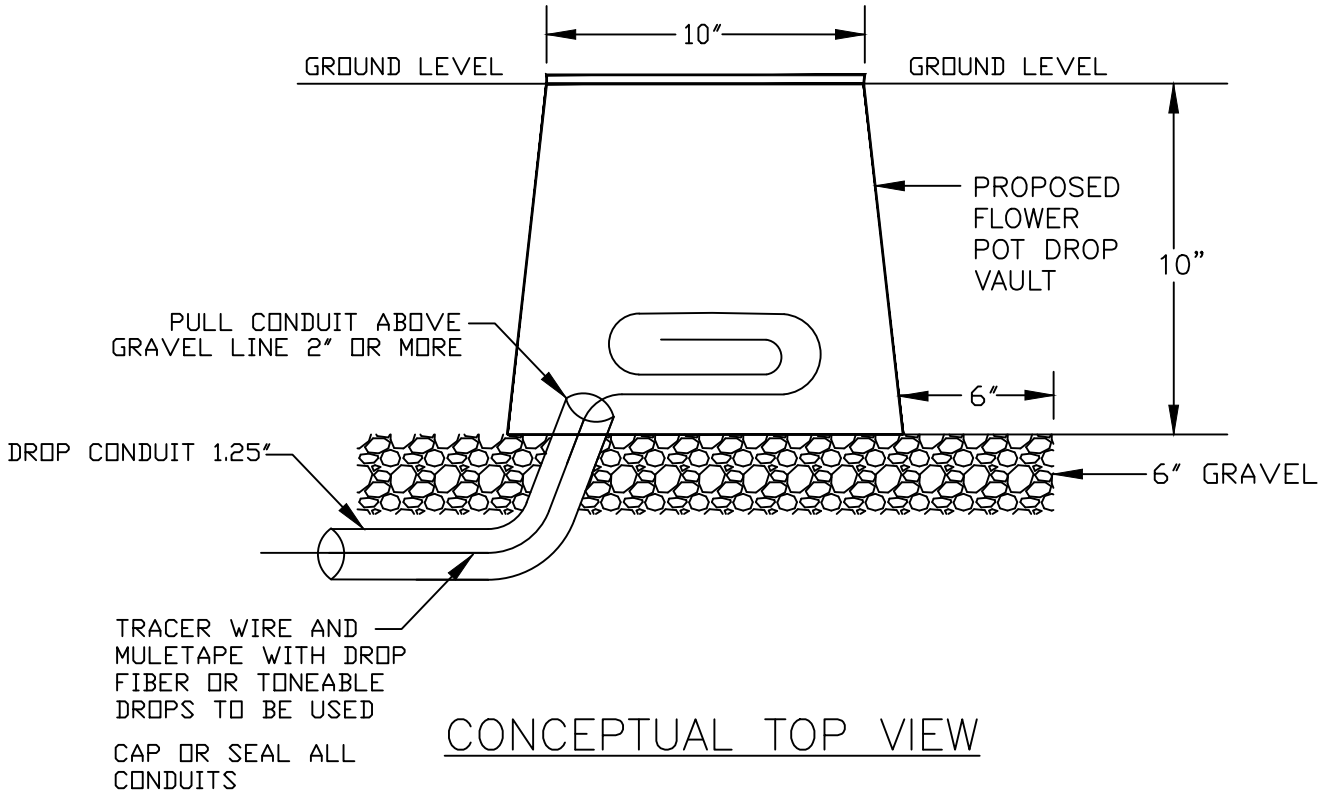

CONCEPTUAL TOP VIEW

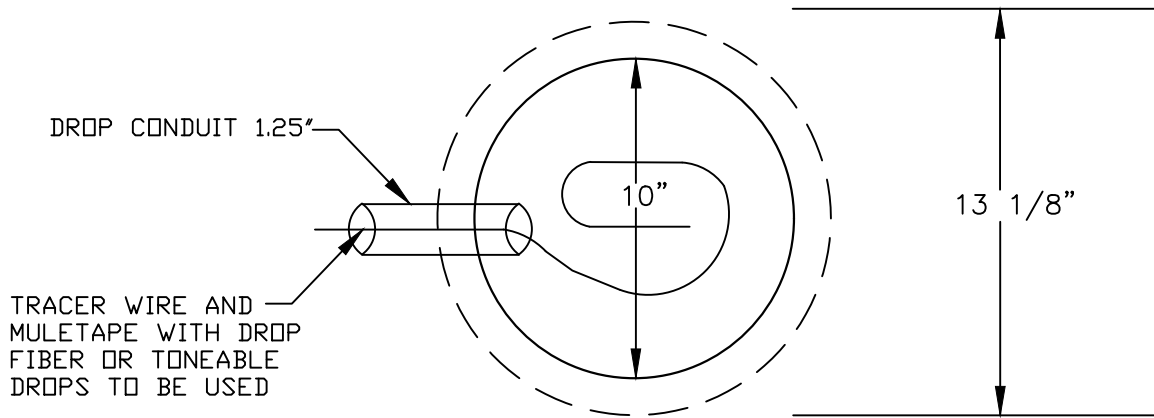

FLOWER POT

30"x48" PC UNIT, 2PC TIER 15/22
 18", 24", and 36" HEIGHT



AMERICAN POLYMER COMPANY

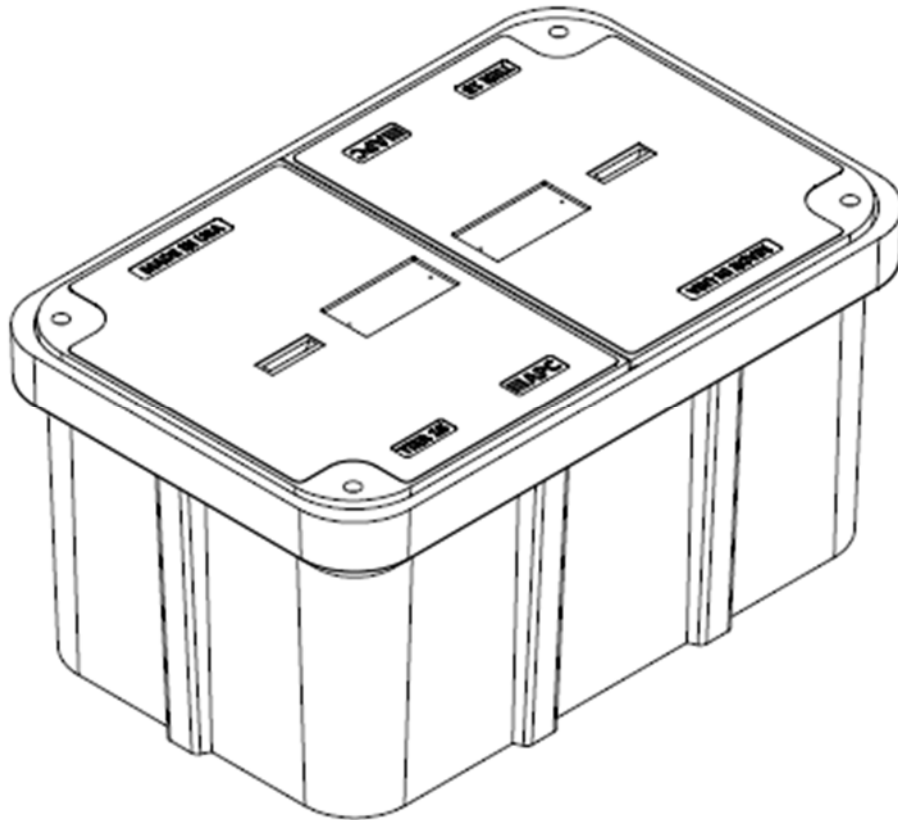

Description	Nominal Size	ANSI Tier	Part Number	Estimated Weight
PC Unit – TIER 15	30"x48"x18"	Tier 15	P304818HU15...	460 lbs.
PC Unit – TIER 22	30"x48"x18"	Tier 22	P304818HU22...	525 lbs.
PC Unit – TIER 15	30"x48"x24"	Tier 15	P304824HU15...	510 lbs.
PC Unit – TIER 22	30"x48"x24"	Tier 22	P304824HU22...	575 lbs.
PC Unit – TIER 15	30"x48"x36"	Tier 15	P304836HU15...	615 lbs.
PC Unit – TIER 22	30"x48"x36"	Tier 22	P304836HU22...	680 lbs.



30"x48" PC UNIT, 2PC TIER 15/22

18", 24", and 36" HEIGHT



AMERICAN POLYMER COMPANY

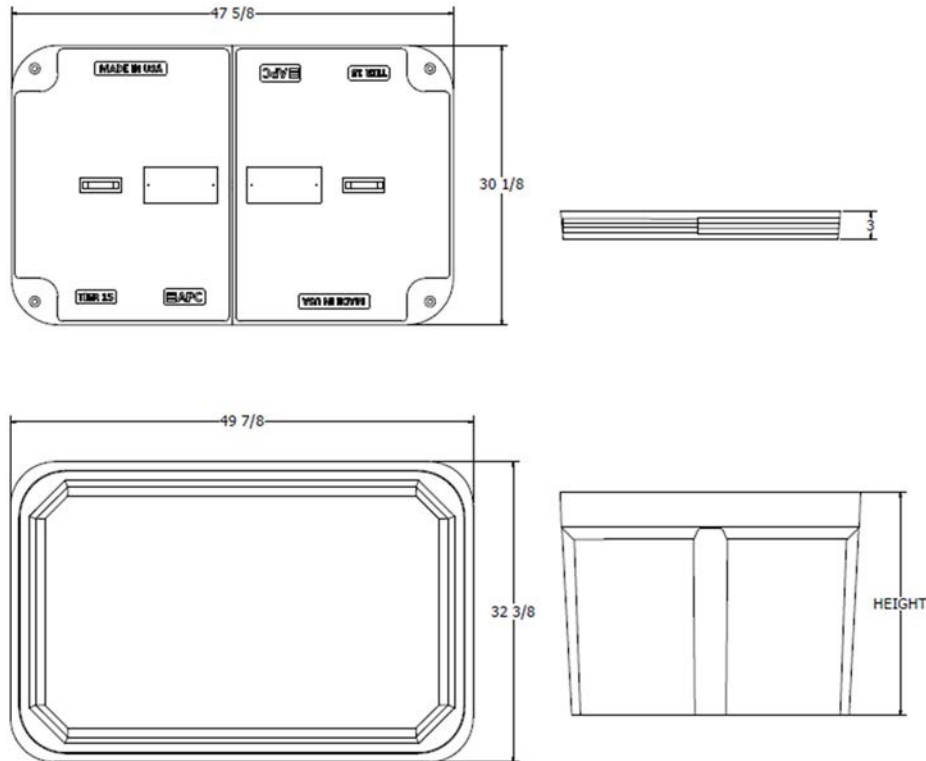

Components	Nominal Size	ANSI Tier	Part Number	Estimated Weight
Replacement Box	30"x48"x18"	Tier 22	P304818B22	185 lbs.
Replacement Box	30"x48"x24"	Tier 22	P304824B22	235 lbs.
Replacement Box	30"x48"x36"	Tier 22	P304836B22	340 lbs.
Replacement Lids - T15	30"x48" (half)	Tier 15	Various	150 lbs.
Replacement Lids - T22	30"x48" (half)	Tier 22	Various	170 lbs.

Bolt options



Machine Thread



Auger Thread



24"x36" PC UNIT, TIER 15/22
 18", 24", 30", and 36" HEIGHT



AMERICAN POLYMER COMPANY

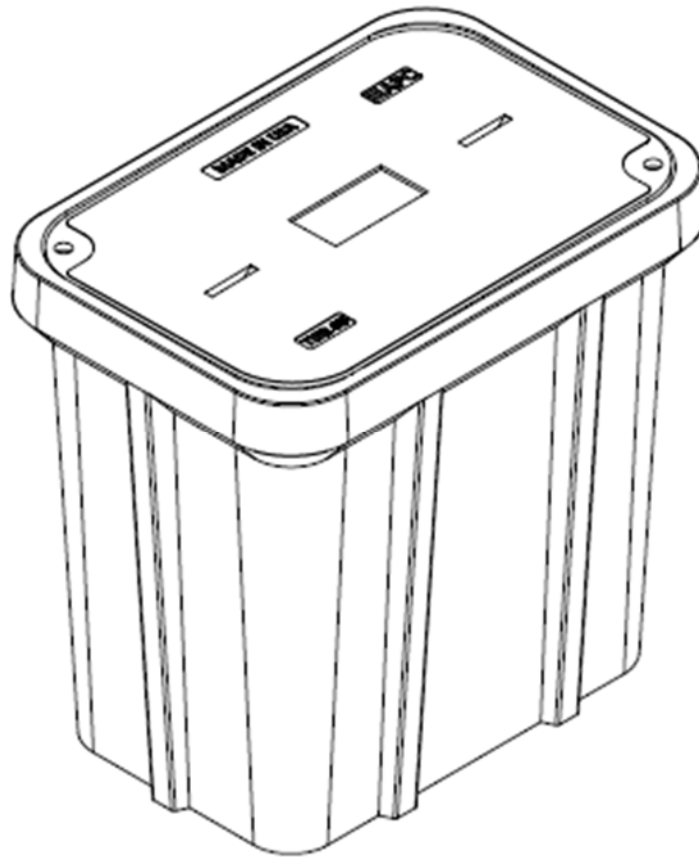

Description	Nominal Size	ANSI Tier	Part Number	Estimated Weight
PC Unit – TIER 15	24x36"x18"	Tier 15	P243618U15...	335 lbs.
PC Unit – TIER 22	24x36"x18"	Tier 22	P243618U22...	355 lbs.
PC Unit – TIER 15	24x36"x24"	Tier 15	P243624U15...	365 lbs.
PC Unit – TIER 22	24x36"x24"	Tier 22	P243624U22...	385 lbs.
PC Unit – TIER 15	24x36"x30"	Tier 15	P243630U15...	395 lbs.
PC Unit – TIER 22	24x36"x30"	Tier 22	P243630U22...	415 lbs.
PC Unit – TIER 15	24x36"x36"	Tier 15	P243636U15...	425 lbs.
PC Unit – TIER 22	24x36"x36"	Tier 22	P243636U22...	445 lbs.



24"x36" PC UNIT, TIER 15/22

18", 24", 30", and 36" HEIGHT



AMERICAN POLYMER COMPANY

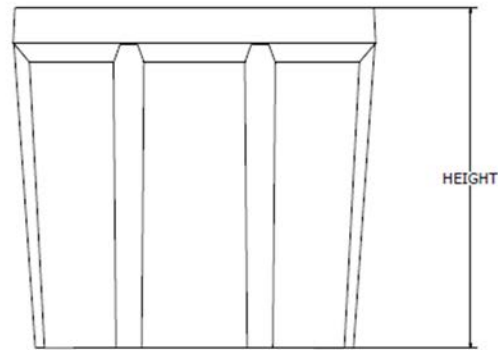
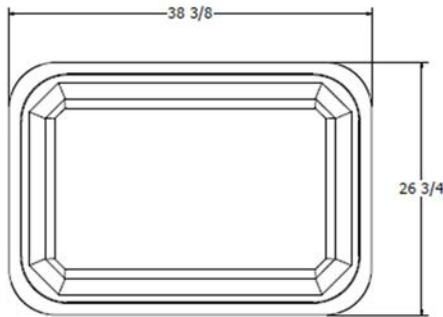
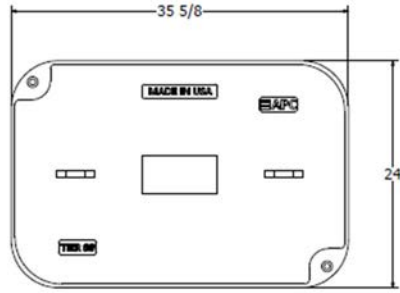

Components	Nominal Size	ANSI Tier	Part Number	Estimated Weight
Replacement Box	24"x36"x18"	Tier 22	P243618B22	165 lbs.
Replacement Box	24"x36"x24"	Tier 22	P243624B22	195 lbs.
Replacement Box	24"x36"x30"	Tier 22	P243630B22	225 lbs.
Replacement Box	24"x36"x36"	Tier 22	P243636B22	255 lbs.
Replacement Lids - T15	24"x36"	Tier 15	Various	170 lbs.
Replacement Lids - T22	24"x36"	Tier 22	Various	190 lbs.

Bolt options

Hex Head



Machine Thread



Penta Head



Auger Thread



17"x30" PC UNIT, TIER 15/22

12", 18", 24", and 30" HEIGHT



AMERICAN POLYMER COMPANY

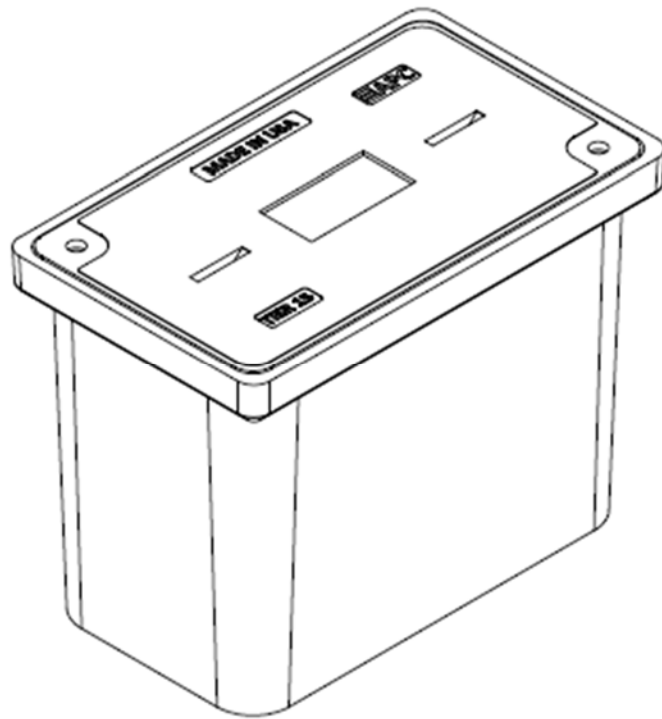

Description	Nominal Size	ANSI Tier	Part Number	Estimated Weight
PC Unit - TIER 15	17"x30"x12"	Tier 15	P173012U15...	138 lbs.
PC Unit - TIER 22	17"x30"x12"	Tier 22	P173012U22...	147 lbs.
PC Unit - TIER 15	17"x30"x18"	Tier 15	P173018U15...	172 lbs.
PC Unit - TIER 22	17"x30"x18"	Tier 22	P173018U22...	181 lbs.
PC Unit - TIER 15	17"x30"x24"	Tier 15	P173024U15...	192 lbs.
PC Unit - TIER 22	17"x30"x24"	Tier 22	P173024U22...	201 lbs.
PC Unit - TIER 15	17"x30"x30"	Tier 15	P173030U15...	217 lbs.
PC Unit - TIER 22	17"x30"x30"	Tier 22	P173030U22...	226 lbs.



17"x30" PC UNIT, TIER 15/22

12", 18", 24", and 30" HEIGHT



AMERICAN POLYMER COMPANY

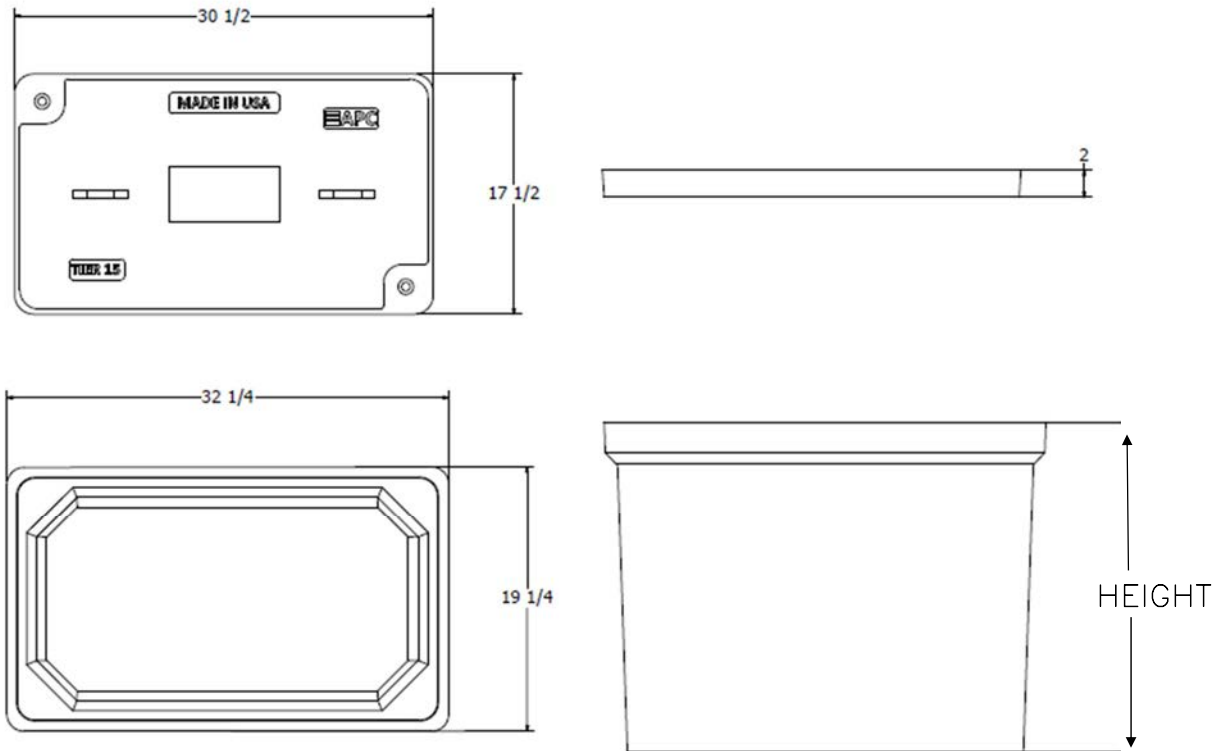

Components	Nominal Size	ANSI Tier	Part Number	Estimated Weight
Replacement Box	17"x30"x12"	Tier 22	P173012B22	66 lbs.
Replacement Box	17"x30"x18"	Tier 22	P173018B22	100 lbs.
Replacement Box	17"x30"x24"	Tier 22	P173024B22	120 lbs.
Replacement Box	17"x30"x30"	Tier 22	P173030B22	145 lbs.
Replacement Lids - T15	17"x30"	Tier 15	Various	72 lbs.
Replacement Lids - T22	17"x30"	Tier 22	Various	81 lbs.

Bolt options



Machine Thread



Auger Thread



33"x60" PC UNIT, 2PC TIER 15/22
36" HEIGHT



AMERICAN POLYMER COMPANY

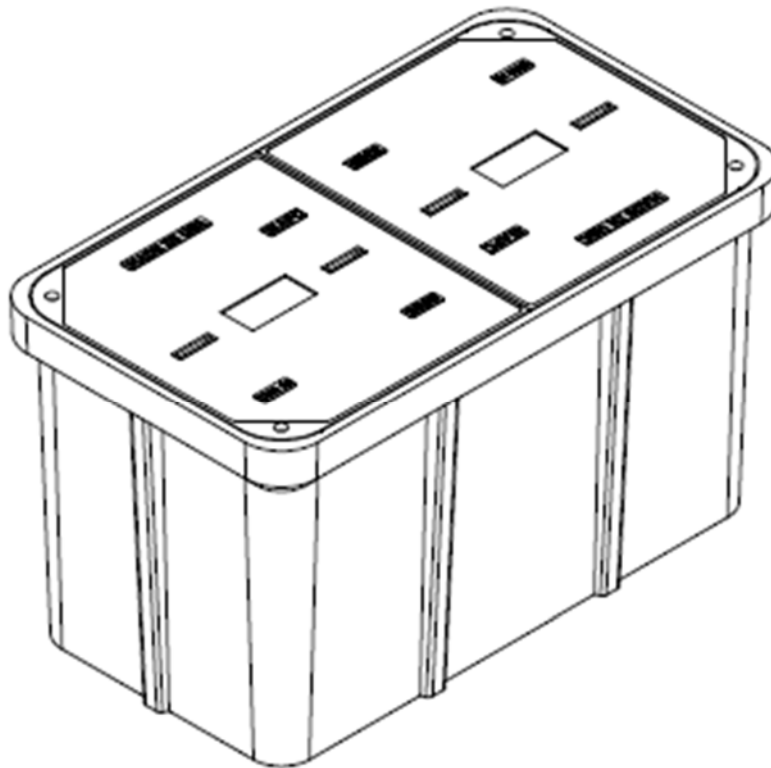

Description	Nominal Size	ANSI Tier	Part Number	Estimated Weight
PC Unit - TIER 15	33"x60"x36"	Tier 15	P336036U15...	930 lbs.
PC Unit - TIER 22	33"x60"x36"	Tier 22	P336036U22...	1030 lbs.



33"x60" PC UNIT, 2PC TIER 15/22

36" HEIGHT



AMERICAN POLYMER COMPANY

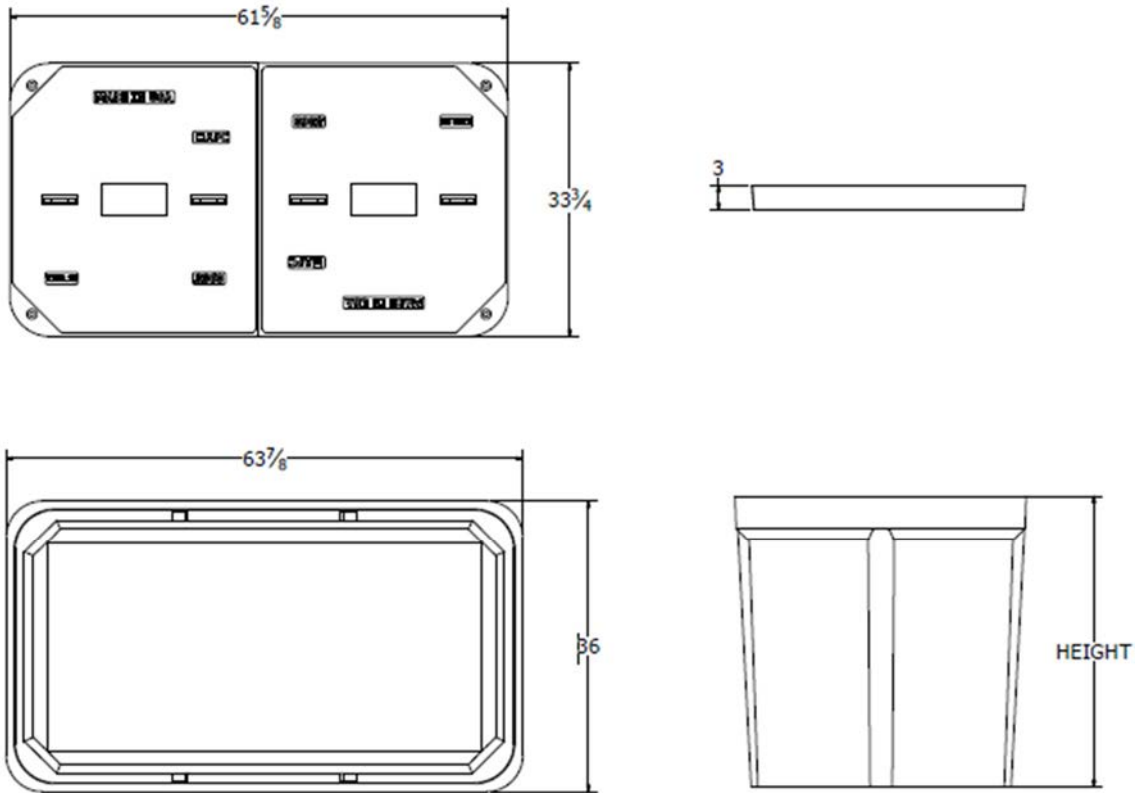

Components	Nominal Size	ANSI Tier	Part Number	Estimated Weight
Replacement Box	33"x60"x36"	Tier 22	P336036B22	530 lbs.
Replacement Lids - T15	33"x60" (half)	Tier 15	Various	200 lbs.
Replacement Lids - T22	33"x60" (half)	Tier 22	Various	250 lbs.

Bolt options

Hex Head



Machine Thread



Penta Head



Auger Thread



Spacing Charts Based on MUTCD		Must be Approved by an Engineer					
Speed (MPH) Prior To Road Work	SIGN SPACING, FT.		BUFFER SPACE, FT.	TAPER LENGTH, FT.		CHANNELIZING SPACING, FT.	
	Non-Divided Highways	Divided Highways	Length	Shoulder (10 ft. Width)	Lane (12 ft. Width)	Through Taper	Through Buffer/Work Area
0-35	200	200	250	70	245	35	50
40-45	350	500	360	150	540	40	80
50-55	500	1000	495	185	660	50	100
60-70	SA-1000, SB-1500, SC-2640		730	235	840	60	120
Urban Low Speed - 100 FT							

APPROVED/ACCEPTED BY:
ENGINEER, OWNER, or PRIME CONTRACTOR
 Check for Notice to Proceed.
BL24 - E 16th St - TCP1

Signature: _____
Company: _____

Road Runner Safety Services, Inc.

Date: 9/26/2022 Project: BL24 - E 16th St - TCP1 :
Traffic Control Suggestion For: AEG :
By: Road Runner Safety Services, Inc. : Nathan

Comments:
Drawing not to scale. Traffic control plan must be approved by an engineer. This is a suggestion only. Road Runners Safety Services, Inc. has no liability for this suggested traffic control plan. Actual placement and spacing of all traffic control devices will depend on field conditions and must conform to MUTCD standards.

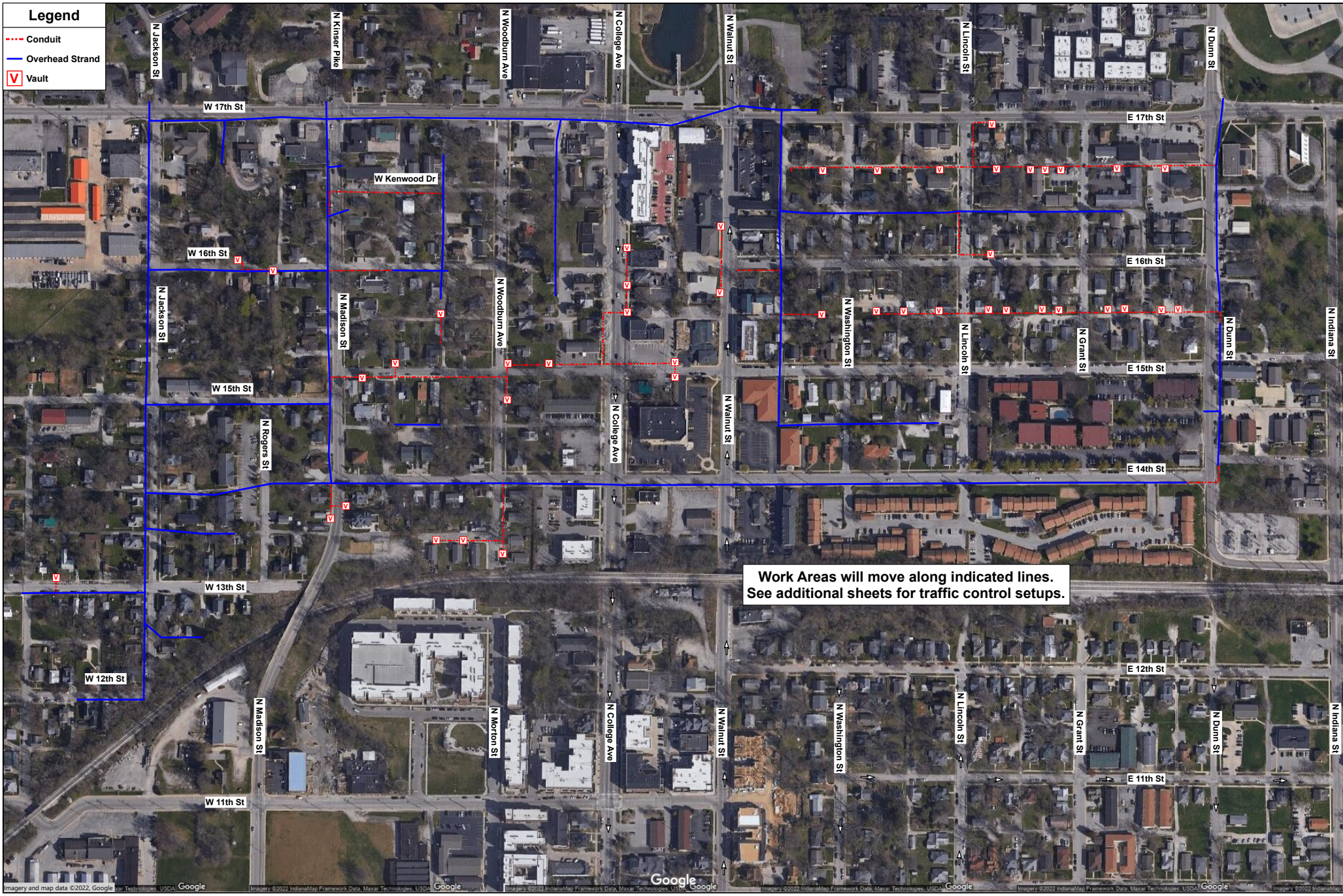

Spacing Charts Based on MUTCD Must be Approved by an Engineer

Speed (MPH) Prior To Road Work	SIGN SPACING, FT.		BUFFER SPACE, FT.	TAPER LENGTH, FT.		CHANNELIZING SPACING, FT.	
	Non-Divided Highways	Divided Highways	Length	Shoulder (10 ft Width)	Lane (12 ft Width)	Through Taper	Through Buffer/Work Area
0-35	200	200	250	70	245	35	50
40-45	350	500	360	150	540	40	80
50-55	500	1000	495	185	660	50	100
60-70	SA-1000, SB-1500, SC-2640		730	235	840	60	120

Urban Low Speed - 100 FT

APPROVED/ACCEPTED BY:
ENGINEER, OWNER, or PRIME CONTRACTOR

Check for Notice to Proceed.
BL24 - E 16th St - TCP2

Signature: _____

Company: _____

Date: 9/26/2022 **Project:** BL24 - E 16th St - TCP2 :
: **Traffic Control Suggestion For:** AEG :
By: Road Runner Safety Services, Inc. : Nathan

Comments:
Drawing not to scale. Traffic control plan must be approved by an engineer. This is a suggestion only. Road Runners Safety Services, Inc. has no liability for this suggested traffic control plan. Actual placement and spacing of all traffic control devices will depend on field conditions and must conform to MUTCD standards.



- Legend**
- ADA Barricade
 - Arrow Board
 - Channelizer
 - Flagger (Person)
 - Sign
 - Vault
 - Work Area



Road Construction Ahead signs to be placed on all side streets within work area.
Sidewalk Closed Ahead Cross Here signs to be placed at nearest crossing.

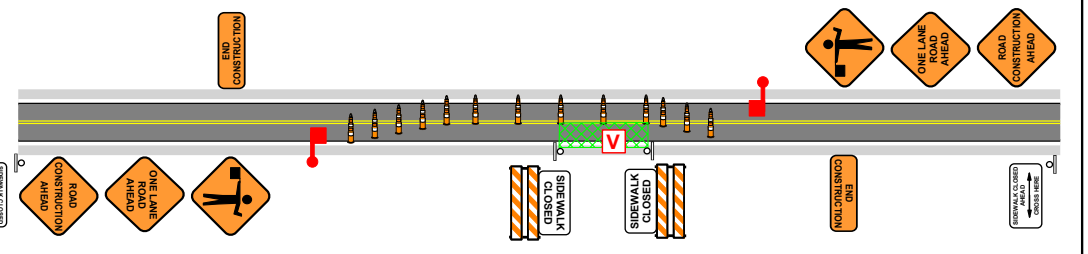
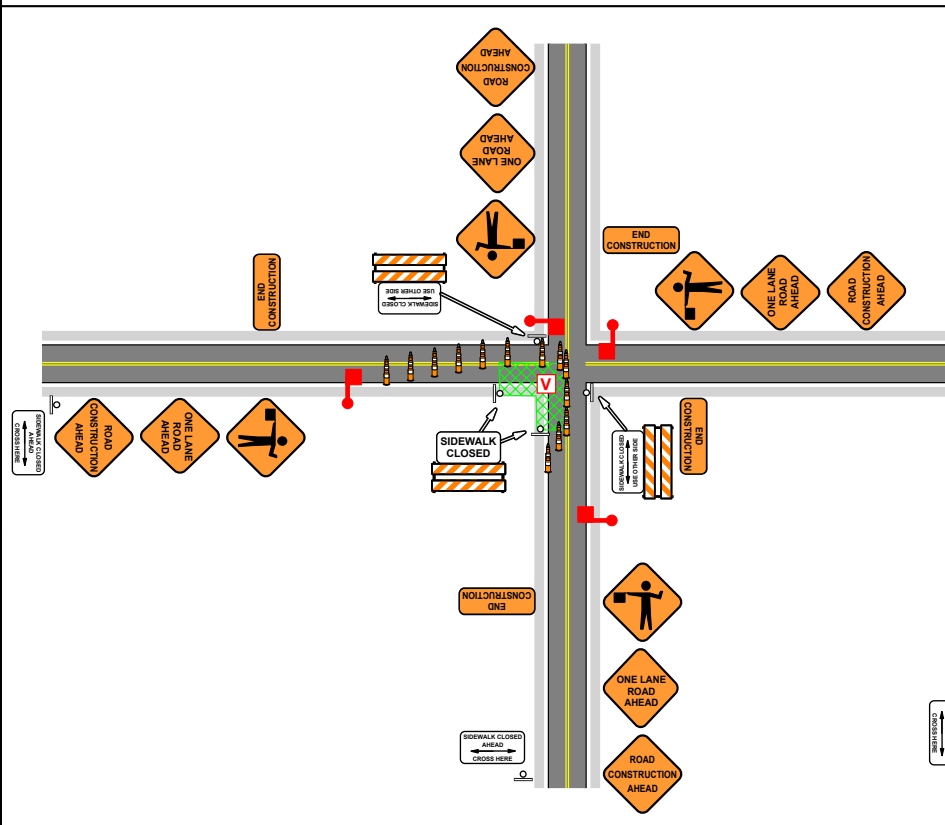

Spacing Charts Based on MUTCD Must be Approved by an Engineer							
Speed (MPH) Prior To Road Work	SIGN SPACING, FT.		BUFFER SPACE, FT.	TAPER LENGTH, FT.		CHANNELIZING SPACING, FT.	
	Non-Divided Highways	Divided Highways	Length	Shoulder (10 ft Width)	Lane (12 ft Width)	Through Taper	Through Buffer/Work Area
0-35	200	200	250	70	245	35	50
40-45	350	500	360	150	540	40	80
50-55	500	1000	495	185	660	50	100
60-70	SA-1000, SB-1500, SC-2640		730	235	840	60	120
	Urban Low Speed - 100 FT						

APPROVED/ACCEPTED BY:
ENGINEER, OWNER, or PRIME CONTRACTOR
 Check for Notice to Proceed.
BL24 - E 16th St - TCP3

Signature: _____

Company: _____

Date: 9/26/2022 **Project:** BL24 - E 16th St - TCP3 :
Traffic Control Suggestion For: AEG :
By: Road Runner Safety Services, Inc. : Nathan

Comments:
Drawing not to scale. Traffic control plan must be approved by an engineer. This is a suggestion only. Road Runners Safety Services, Inc. has no liability for this suggested traffic control plan. Actual placement and spacing of all traffic control devices will depend on field conditions and must conform to MUTCD standards.

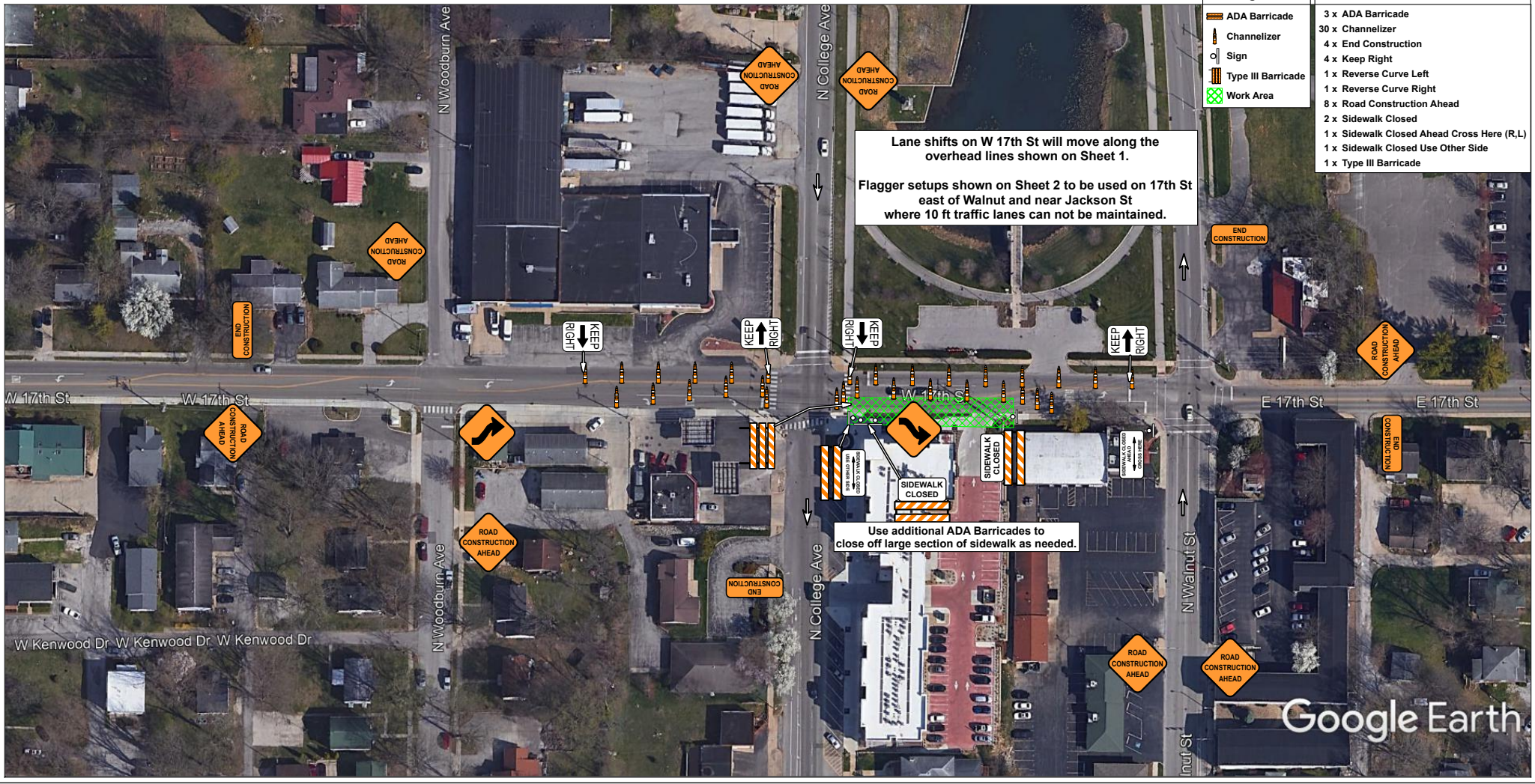

Legend	Manifest
ADA Barricade	3 x ADA Barricade
Channelizer	30 x Channelizer
Sign	4 x End Construction
Type III Barricade	4 x Keep Right
Work Area	1 x Reverse Curve Left
	1 x Reverse Curve Right
	8 x Road Construction Ahead
	2 x Sidewalk Closed
	1 x Sidewalk Closed Ahead Cross Here (R,L)
	1 x Sidewalk Closed Use Other Side
	1 x Type III Barricade

Google Earth

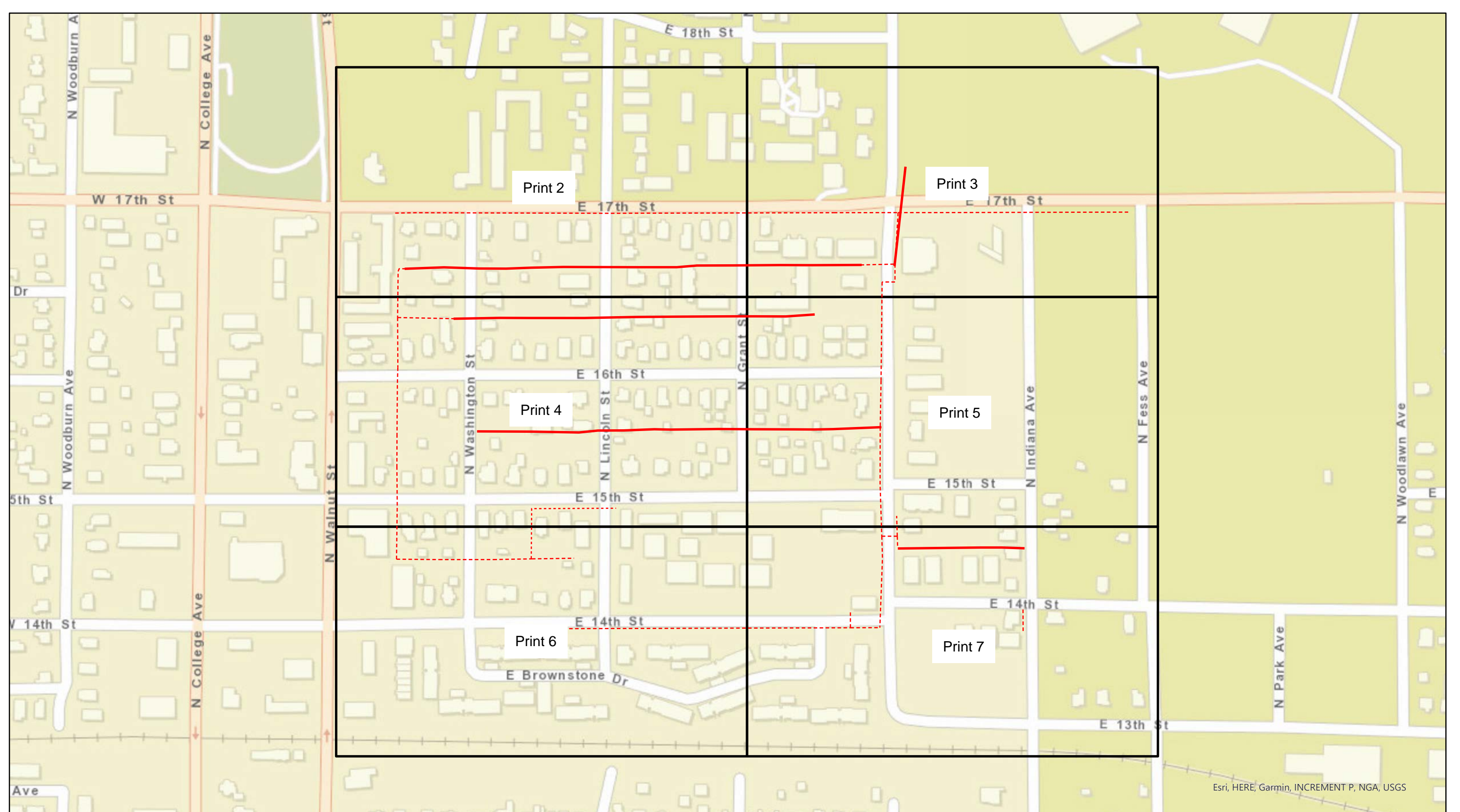

Esri, HERE, Garmin, INCREMENT P, NGA, USGS



Legend BLN01a-F14_N Lincoln St

- Overhead Strand
- ⋯ Conduit
- Grids



City of Bloomington, IN Permit:
Design View

INI	BY	DATE	DESCRIPTION

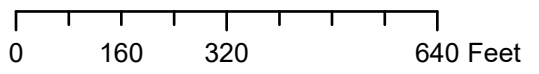

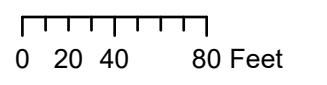
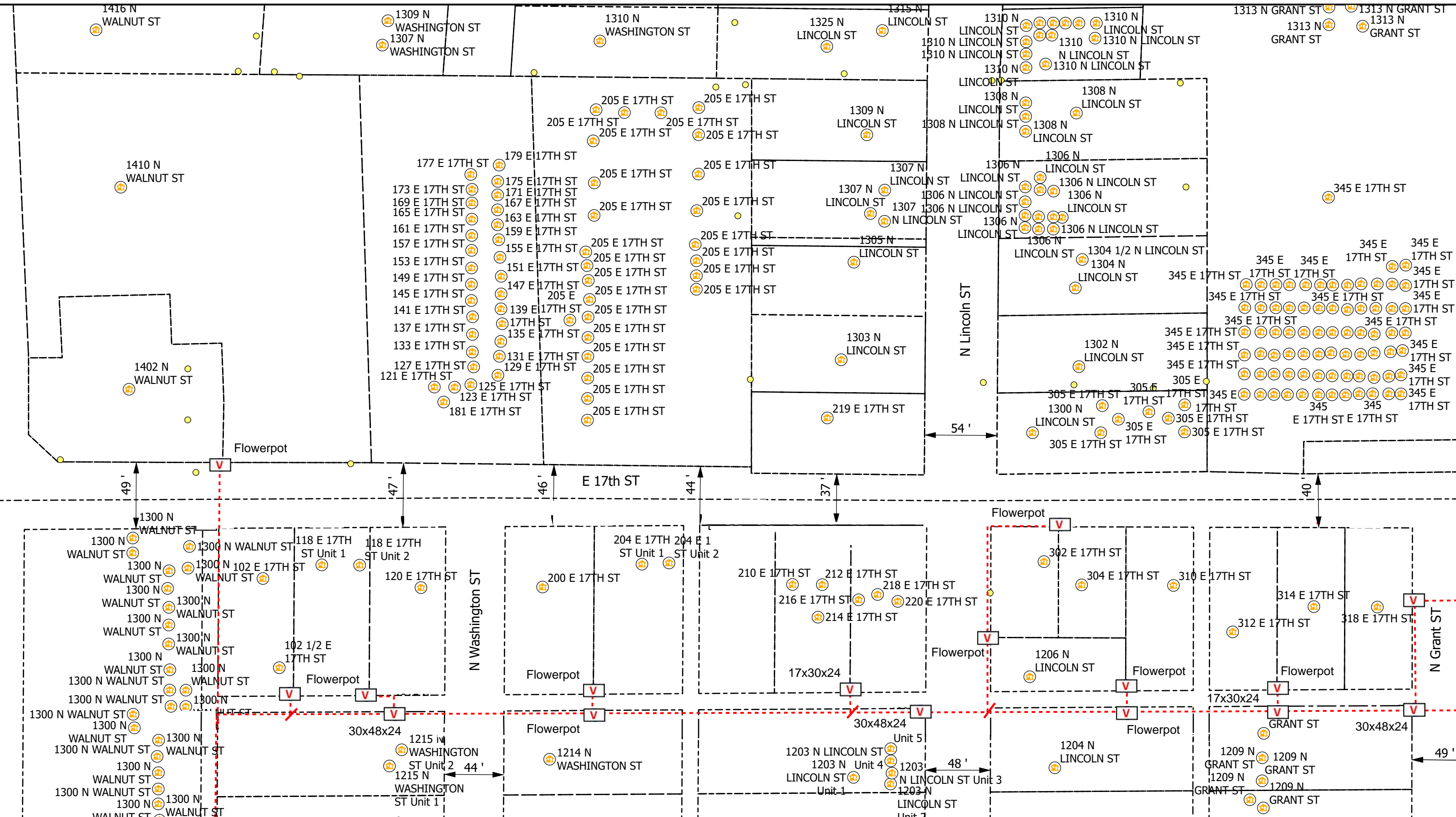

Legend

- Poles
- Ⓡ Risers
- Ⓜ Sidewalk
- V Vaults
- Ⓜ Address
- Bloomington_Parcels
- Overhead Strand
- - - Conduit
- Y Anchor
- Grids

All Flowerpots 12" DIA



City of Bloomington, IN Permit:
Design View

INI	BY	DATE	DESCRIPTION



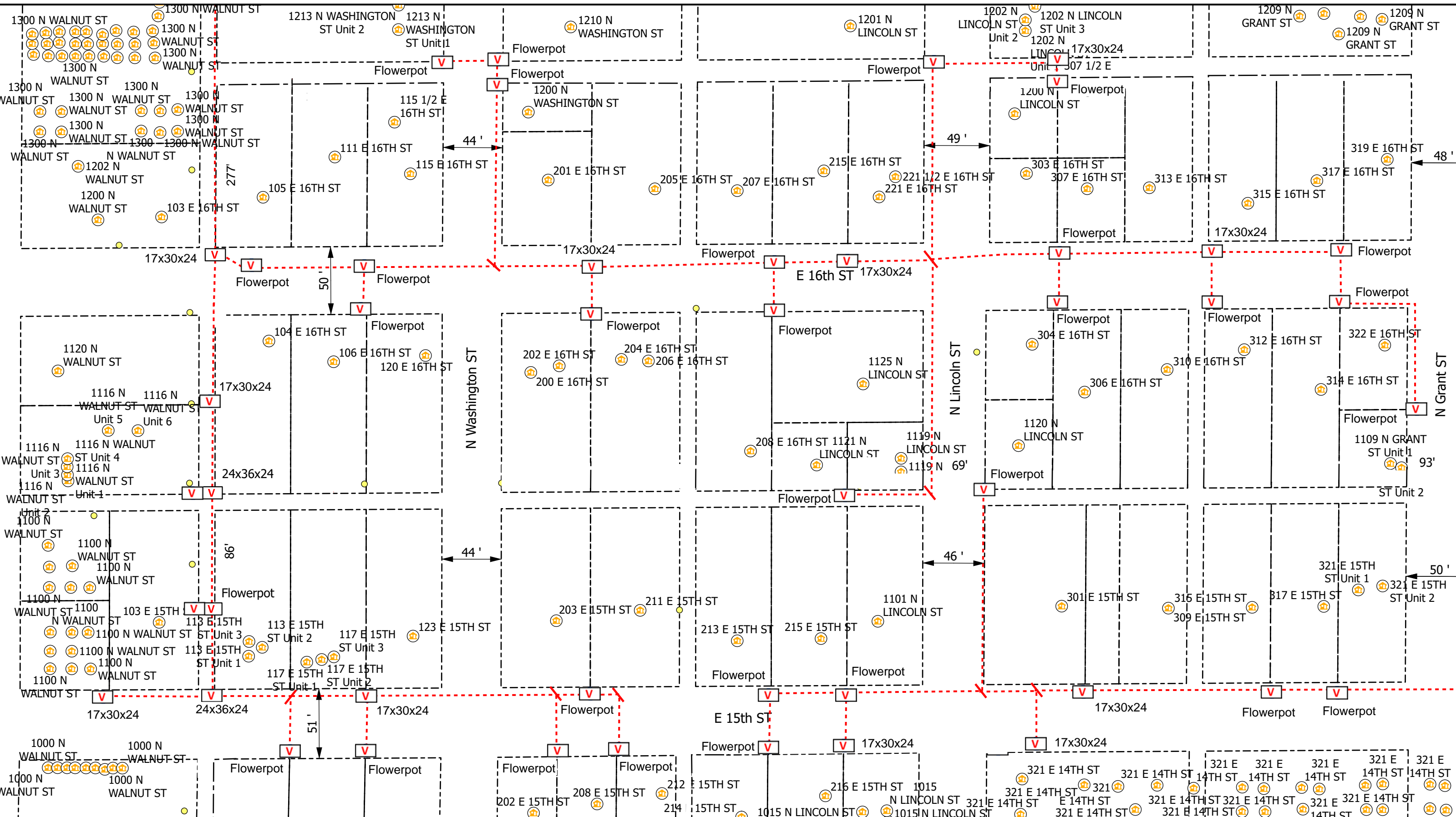

Legend

- Poles
- Ⓡ Risers
- Ⓜ Vaults
- 🏠 Address
- Overhead Strand
- ⚓ Anchor
- - - Conduit
- ↖ Sidewalk
- ⊠ Bloomington_Parcels
- ▭ Grids

All Flowerpots 12" DIA

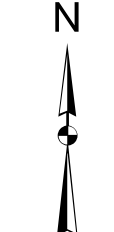

City of Bloomington, IN Permit:
Design View

INI	BY	DATE	DESCRIPTION

Print 4 of 7

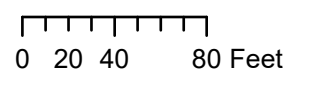
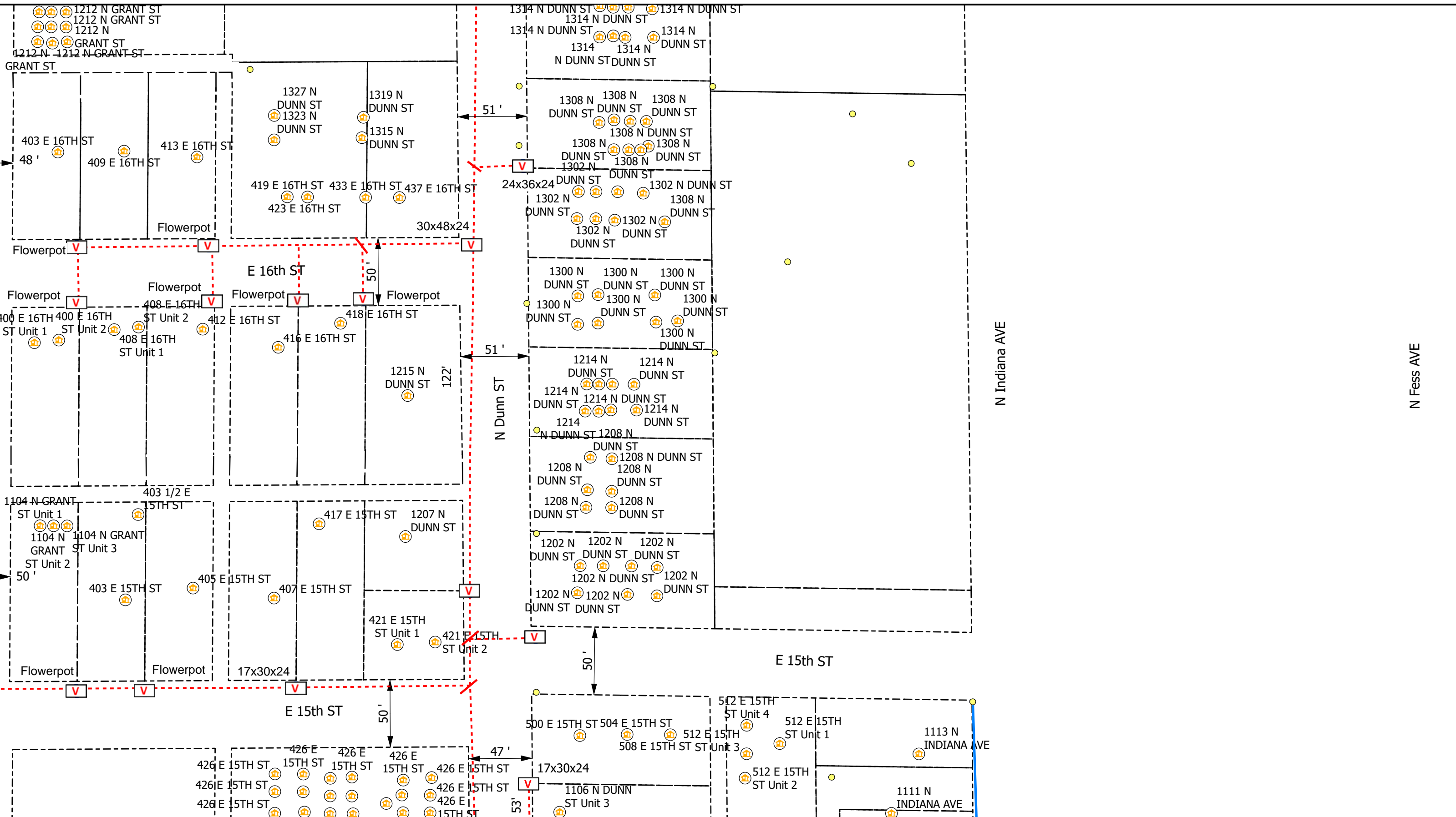

Legend

- Poles
- V Vaults
- Overhead Strand
- - - Conduit
- Ⓡ Risers
- Ⓜ Address
- Y Anchor
- ↖ Sidewalk
- Bloomington_Parcels
- Grids

All Flowerpots 12" DIA



City of Bloomington, IN Permit:
Design View

INI	BY	DATE	DESCRIPTION



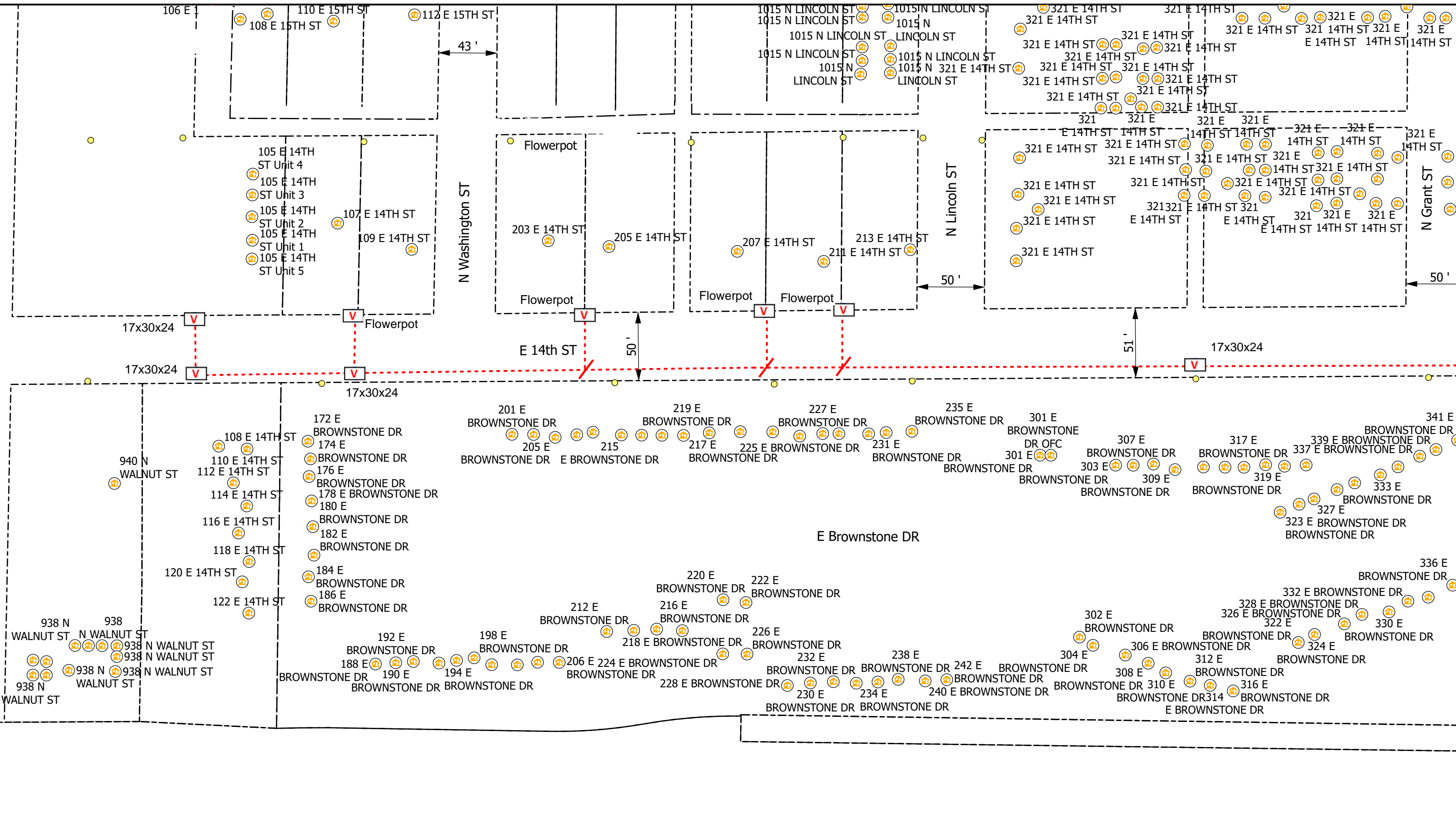

Legend

- Poles
- Vaults
- Risers
- Sidewalk
- Overhead Strand
- Address
- Anchor
- Bloomington_Parcels
- Grids
- Conduit

All Flowerpots 12" DIA



City of Bloomington, IN Permit:
Design View

INI	BY	DATE	DESCRIPTION



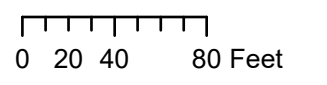
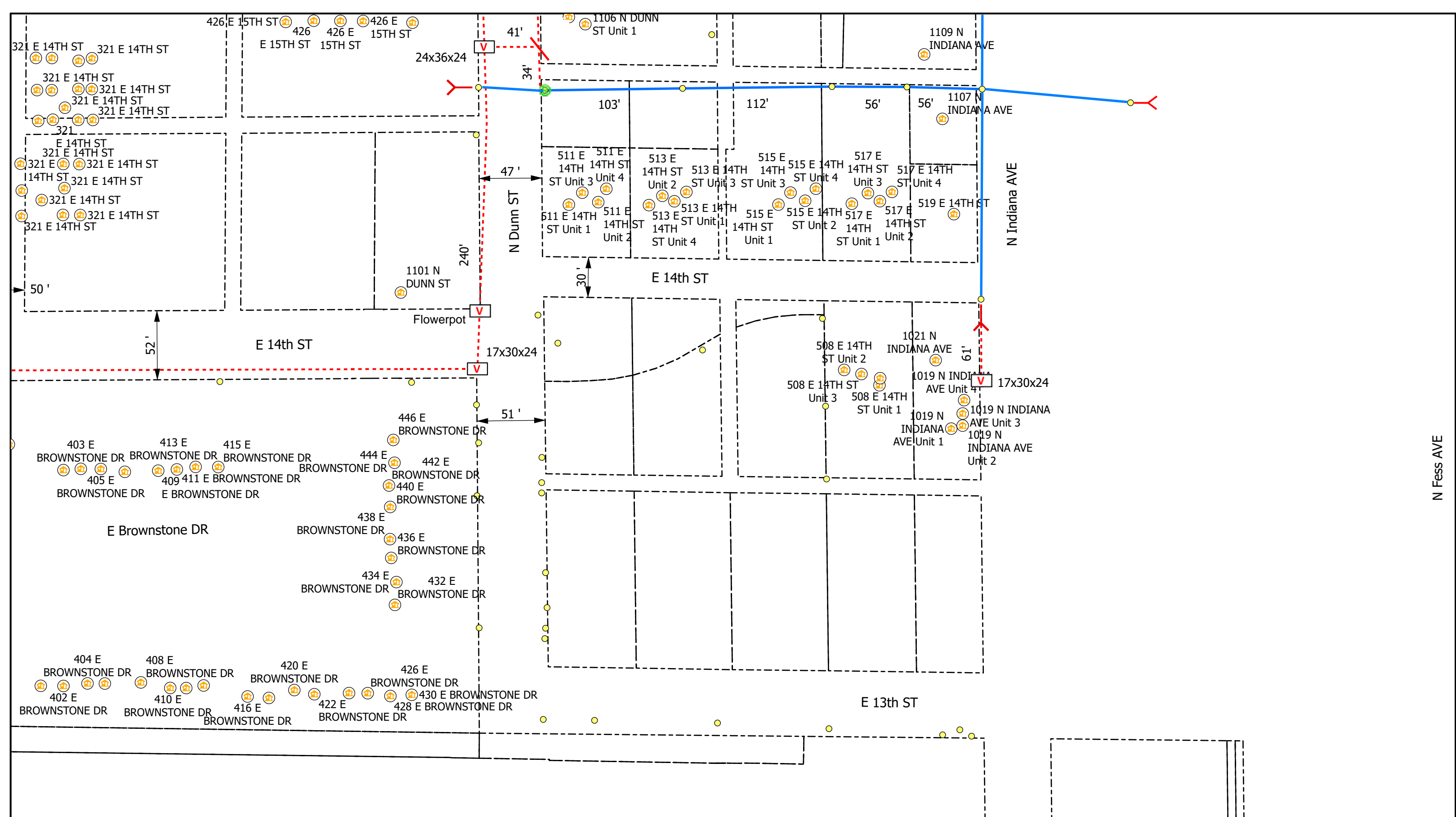

Legend

- Poles
- V Vaults
- Overhead Strand
- Conduit
- R Risers
- Ⓜ Address
- Y Anchor
- └─┘ Sidewalk
- Bloomington_Parcels
- Grids

All Flowerpots 12" DIA



City of Bloomington, IN Permit:
Design View

INI	BY	DATE	DESCRIPTION



Carlton® PV-Mold® Nonmetallic Pole Riser System

Carlton PV-Mold is a nonmetallic pole riser system designed to protect communications power cable installed on poles.

Features:

- Meets or exceeds requirements outlined in the National Electric Safety Code (NESC).
- Designed in accordance with NEMA TC-19 specifications.
- Ultraviolet, cold temperature and corrosive atmosphere resistant.
- Schedule 40 wall meets Schedule 80 PVC conduit impact requirements per NEMA TC-19.
- No grounding required.
- Belled end fits over each added section or conduit.
- Flame retardant.
- Requires no maintenance.
- PV-Mold acts as an insulator against electrical shock.
- Interchangeable parts and accessories to match the needs of specific requirements.



Steel U-Guard requires grounding strapping and does not have belled ends.



PV-Mold has belled ends, flanged design and does not require grounding.

Flanged Overall Length 10 Feet, Including Bell

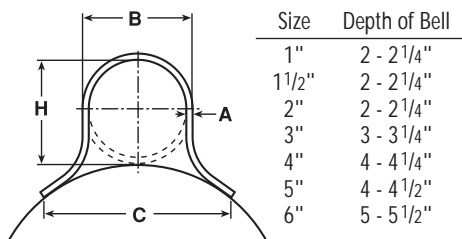

Slots are 1/2" from side to side, and allow for expansion and contraction.

Slot Dimensions: for sizes 2" through 6" are 5/16" wide, 3/4" long.

Slot Dimensions: for 1" and 1 1/2" are 3/16" wide, 3/4" long.

Slot Spacing: 18" from center, beginning 6" from end.

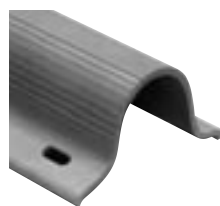

Standard Duty

Part No.	Size	Std. Ctn. Qty.	Std. Ctn. Wt. (lbs.)	Dimensions				Actual Impact @ 0°C 20 Pound Top
				A	B	C	H	
59208N	1"	294	1059	0.100"	1 5/8"	2 3/8"	1 5/8"	40 Ft.-Lbs.
59211N	2"	136	726	0.100"	2 3/8"	4 1/2"	2 3/8"	100 Ft.-Lbs.
59211X (5' length)	2"	136	363	0.100"	2 3/8"	4 1/2"	2 3/8"	100 Ft.-Lbs.
59213N	3"	66	761	0.150"	3 1/2"	6"	3 1/2"	110 Ft.-Lbs.
59213X (5' length)	3"	66	381	0.150"	3 1/2"	6"	3 1/2"	100 Ft.-Lbs.
59215N	4"	65	910	0.150"	4 1/2"	6 1/2"	4 1/2"	110 Ft.-Lbs.
59216N	5"	30	515	0.150"	5 1/2"	7 1/2"	5 1/2"	110 Ft.-Lbs.

Heavy Duty Schedule 40

59010N	1 1/2"	200	1142	0.145"	1 29/32"	3 1/2"	1 29/32"	100 Ft.-Lbs.
59011N	2"	136	1214	0.154"	2 3/8"	4 1/2"	2 3/8"	150 Ft.-Lbs.
59013N	3"	66	937	0.216"	3 1/2"	6"	3 9/32"	150 Ft.-Lbs.
59015N	4"	65	1621	0.237"	4 1/2"	6 1/2"	4 1/2"	260 Ft.-Lbs.
59015X (5' length)	4"	65	707	0.237"	4 1/2"	6 1/2"	4 1/2"	260 Ft.-Lbs.
59016N	5"	30	870	0.258"	5 1/2"	7 1/2"	5 1/2"	260 Ft.-Lbs.
59017N	6"	30	1160	0.280"	6 5/8"	8 3/4"	6 5/8"	260 Ft.-Lbs.

Extra Heavy Duty Schedule 80

59411N	2"	136	1549	0.218"	2 3/8"	4 1/2"	2 3/8"	300 Ft.-Lbs.
59413N	3"	66	1495	0.030"	3 1/2"	6"	3 1/2"	525 Ft.-Lbs.

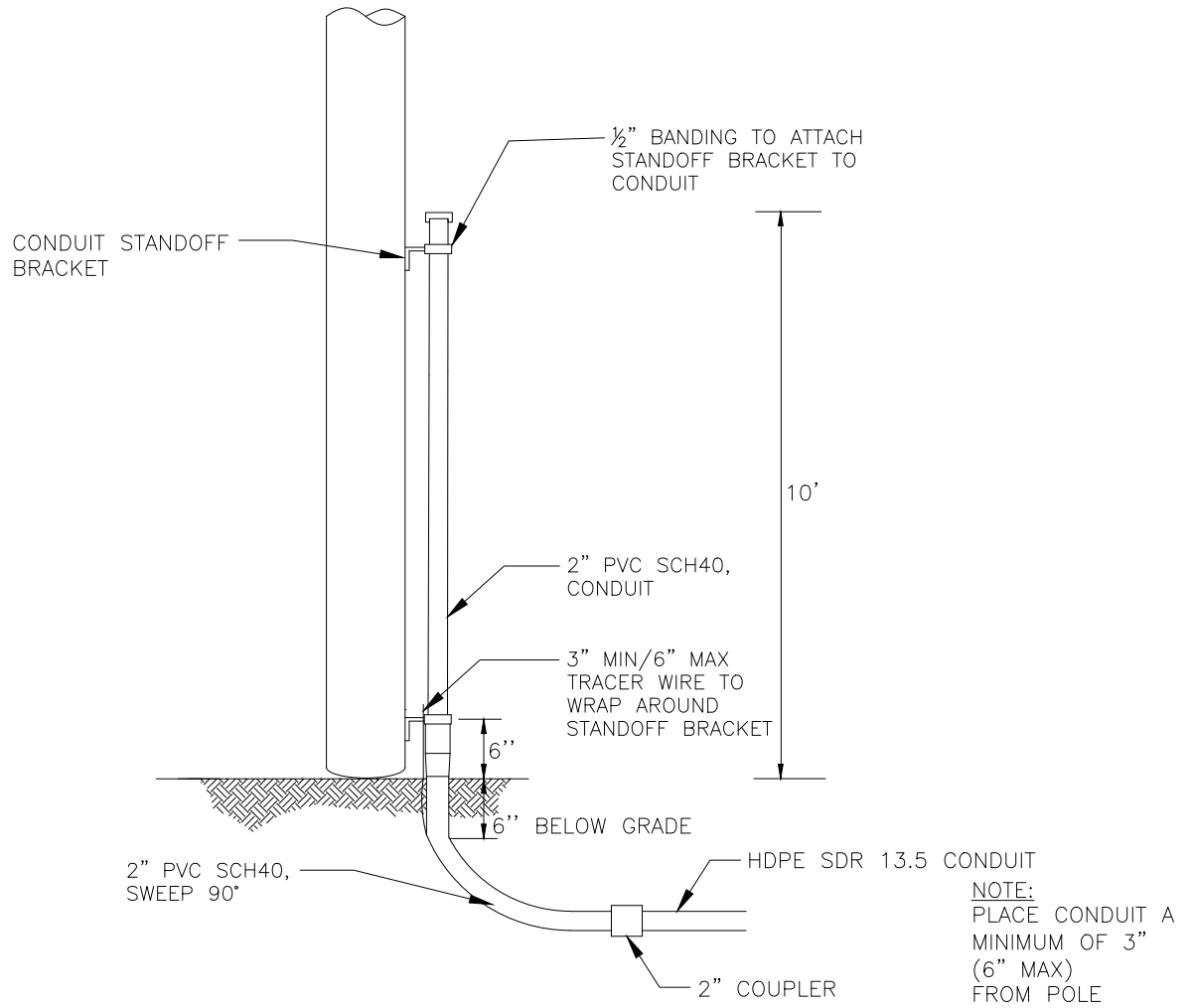

DESCRIPTION	QTY	MANUFACTURER (PREFERRED)	PART #
SCREW, LAG, 1/2" x 4-1/2"	10		
HDPE SDR 13.5 CONDUIT, VARIOUS SIZES	N/A		
2" PVC SCH40, RISER PIPE	1		
#12 TRACER WIRE	N/A		
2" PVC SCH40, SWEEP, 90 DEG	1		
CONDUIT STANDOFF BRACKET	VARIES		
CONDUIT STRAP KIT	VARIES		
2" COUPLER	1		



TYPICAL RISER
CONDUIT
WOOD POLE

(R2-W)

CONCEPTUAL SIDE VIEW

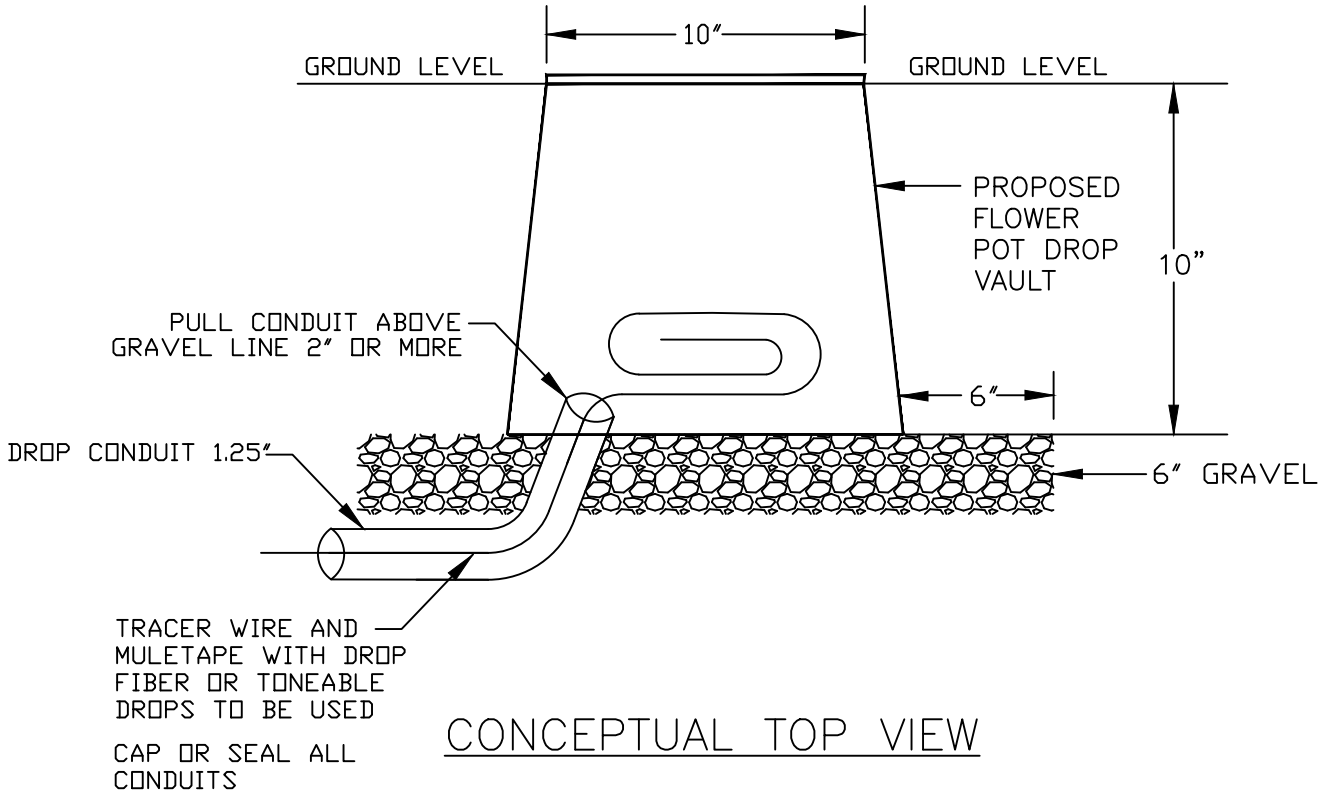

CONCEPTUAL TOP VIEW

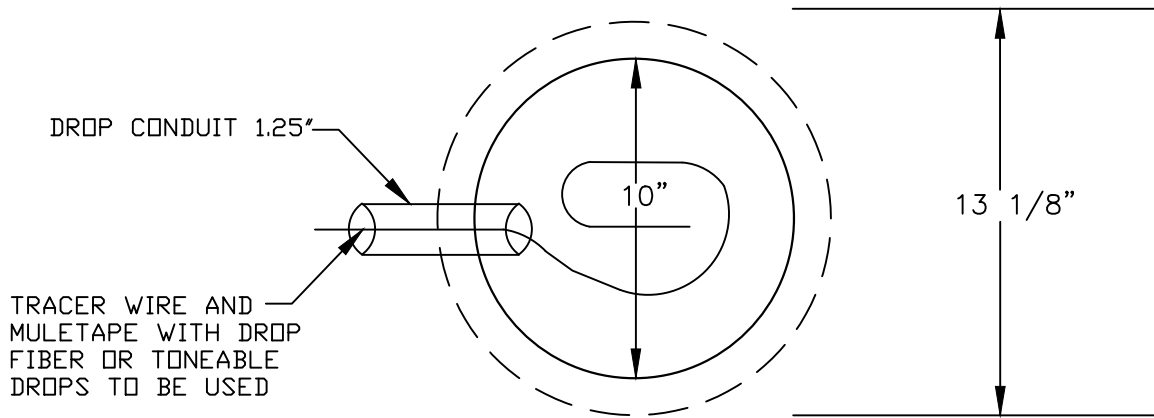

FLOWER POT

30"x48" PC UNIT, 2PC TIER 15/22
 18", 24", and 36" HEIGHT



AMERICAN POLYMER COMPANY

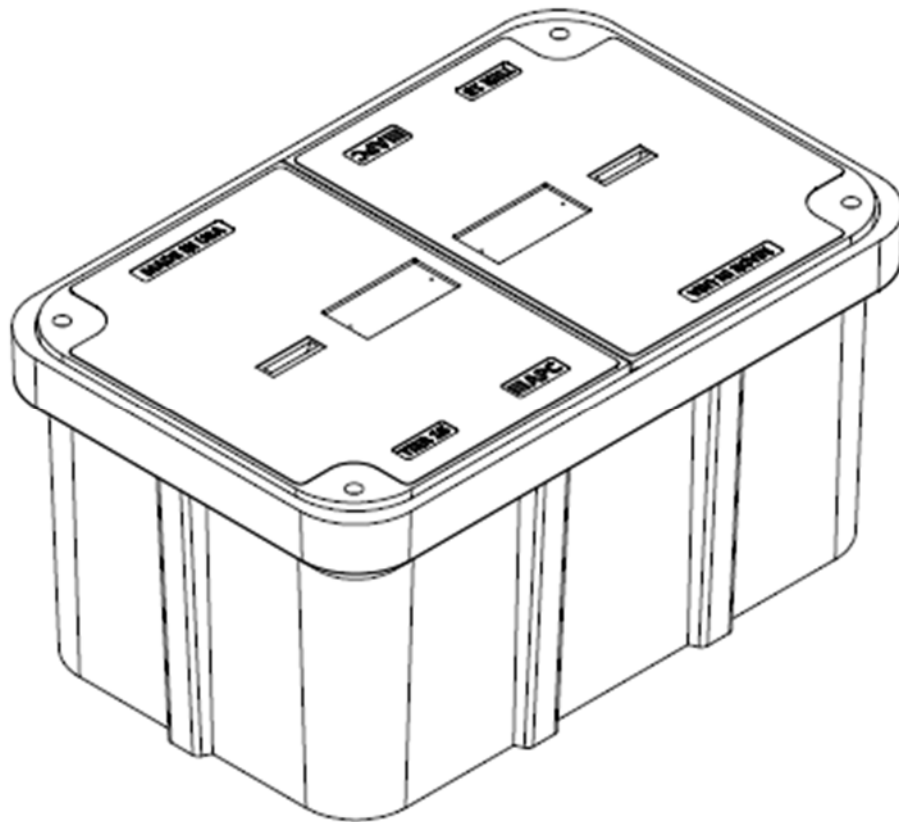

Description	Nominal Size	ANSI Tier	Part Number	Estimated Weight
PC Unit – TIER 15	30"x48"x18"	Tier 15	P304818HU15...	460 lbs.
PC Unit – TIER 22	30"x48"x18"	Tier 22	P304818HU22...	525 lbs.
PC Unit – TIER 15	30"x48"x24"	Tier 15	P304824HU15...	510 lbs.
PC Unit – TIER 22	30"x48"x24"	Tier 22	P304824HU22...	575 lbs.
PC Unit – TIER 15	30"x48"x36"	Tier 15	P304836HU15...	615 lbs.
PC Unit – TIER 22	30"x48"x36"	Tier 22	P304836HU22...	680 lbs.



30"x48" PC UNIT, 2PC TIER 15/22

18", 24", and 36" HEIGHT



AMERICAN POLYMER COMPANY

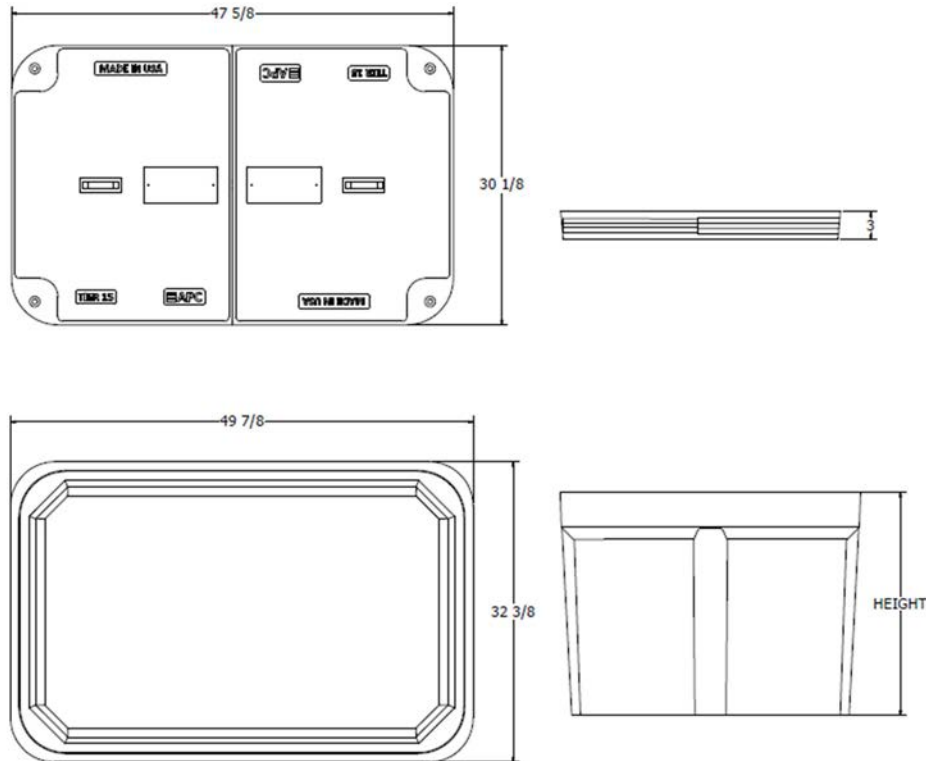

Components	Nominal Size	ANSI Tier	Part Number	Estimated Weight
Replacement Box	30"x48"x18"	Tier 22	P304818B22	185 lbs.
Replacement Box	30"x48"x24"	Tier 22	P304824B22	235 lbs.
Replacement Box	30"x48"x36"	Tier 22	P304836B22	340 lbs.
Replacement Lids - T15	30"x48" (half)	Tier 15	Various	150 lbs.
Replacement Lids - T22	30"x48" (half)	Tier 22	Various	170 lbs.

Bolt options

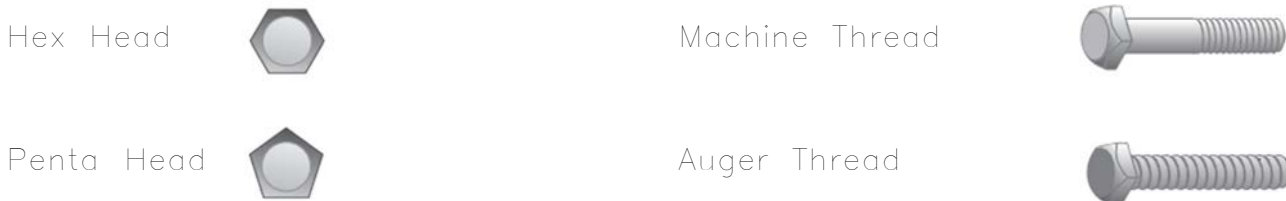

24"x36" PC UNIT, TIER 15/22
 18", 24", 30", and 36" HEIGHT



AMERICAN POLYMER COMPANY

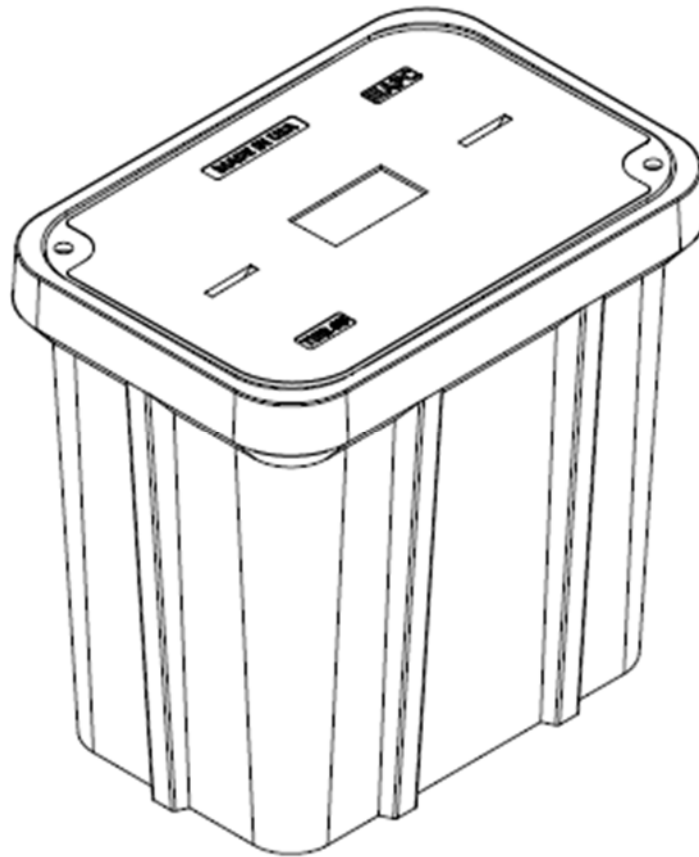

Description	Nominal Size	ANSI Tier	Part Number	Estimated Weight
PC Unit – TIER 15	24x36"x18"	Tier 15	P243618U15...	335 lbs.
PC Unit – TIER 22	24x36"x18"	Tier 22	P243618U22...	355 lbs.
PC Unit – TIER 15	24x36"x24"	Tier 15	P243624U15...	365 lbs.
PC Unit – TIER 22	24x36"x24"	Tier 22	P243624U22...	385 lbs.
PC Unit – TIER 15	24x36"x30"	Tier 15	P243630U15...	395 lbs.
PC Unit – TIER 22	24x36"x30"	Tier 22	P243630U22...	415 lbs.
PC Unit – TIER 15	24x36"x36"	Tier 15	P243636U15...	425 lbs.
PC Unit – TIER 22	24x36"x36"	Tier 22	P243636U22...	445 lbs.



24"x36" PC UNIT, TIER 15/22

18", 24", 30", and 36" HEIGHT



AMERICAN POLYMER COMPANY

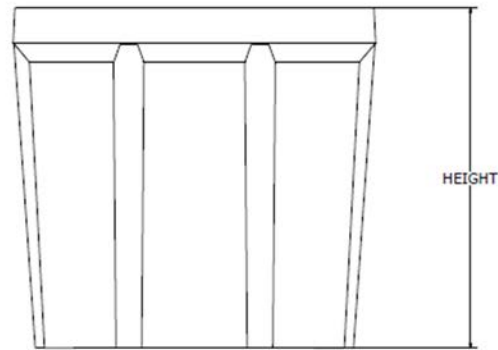
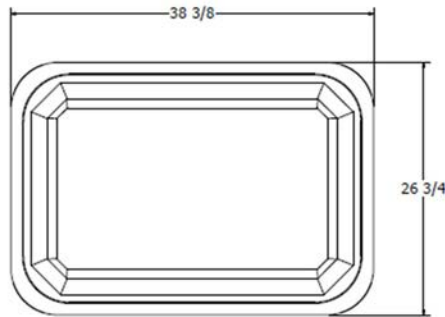
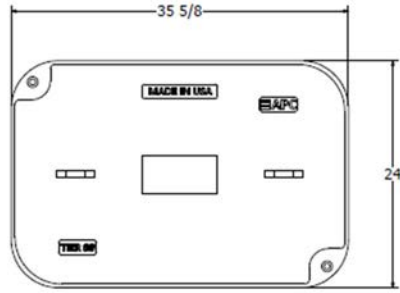

Components	Nominal Size	ANSI Tier	Part Number	Estimated Weight
Replacement Box	24"x36"x18"	Tier 22	P243618B22	165 lbs.
Replacement Box	24"x36"x24"	Tier 22	P243624B22	195 lbs.
Replacement Box	24"x36"x30"	Tier 22	P243630B22	225 lbs.
Replacement Box	24"x36"x36"	Tier 22	P243636B22	255 lbs.
Replacement Lids - T15	24"x36"	Tier 15	Various	170 lbs.
Replacement Lids - T22	24"x36"	Tier 22	Various	190 lbs.

Bolt options

Hex Head



Machine Thread



Penta Head



Auger Thread



17"x30" PC UNIT, TIER 15/22

12", 18", 24", and 30" HEIGHT



AMERICAN POLYMER COMPANY

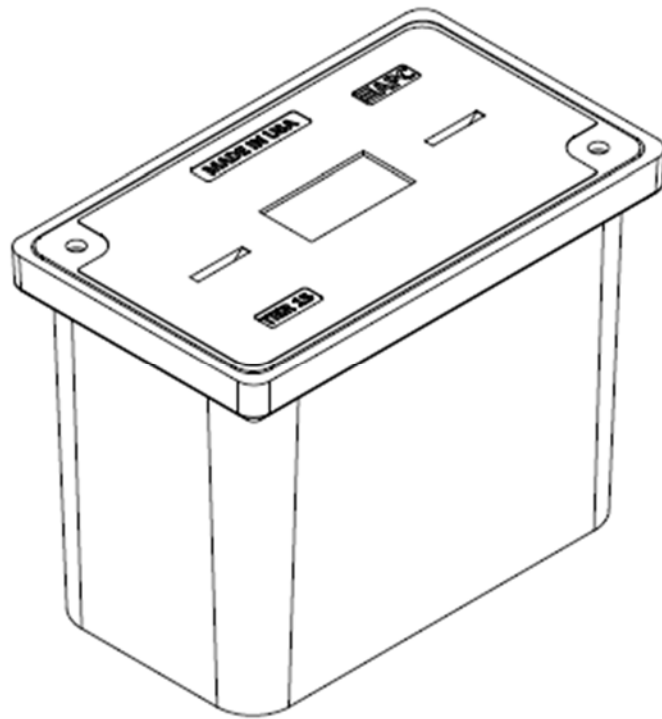

Description	Nominal Size	ANSI Tier	Part Number	Estimated Weight
PC Unit - TIER 15	17"x30"x12"	Tier 15	P173012U15...	138 lbs.
PC Unit - TIER 22	17"x30"x12"	Tier 22	P173012U22...	147 lbs.
PC Unit - TIER 15	17"x30"x18"	Tier 15	P173018U15...	172 lbs.
PC Unit - TIER 22	17"x30"x18"	Tier 22	P173018U22...	181 lbs.
PC Unit - TIER 15	17"x30"x24"	Tier 15	P173024U15...	192 lbs.
PC Unit - TIER 22	17"x30"x24"	Tier 22	P173024U22...	201 lbs.
PC Unit - TIER 15	17"x30"x30"	Tier 15	P173030U15...	217 lbs.
PC Unit - TIER 22	17"x30"x30"	Tier 22	P173030U22...	226 lbs.



17"x30" PC UNIT, TIER 15/22

12", 18", 24", and 30" HEIGHT



AMERICAN POLYMER COMPANY

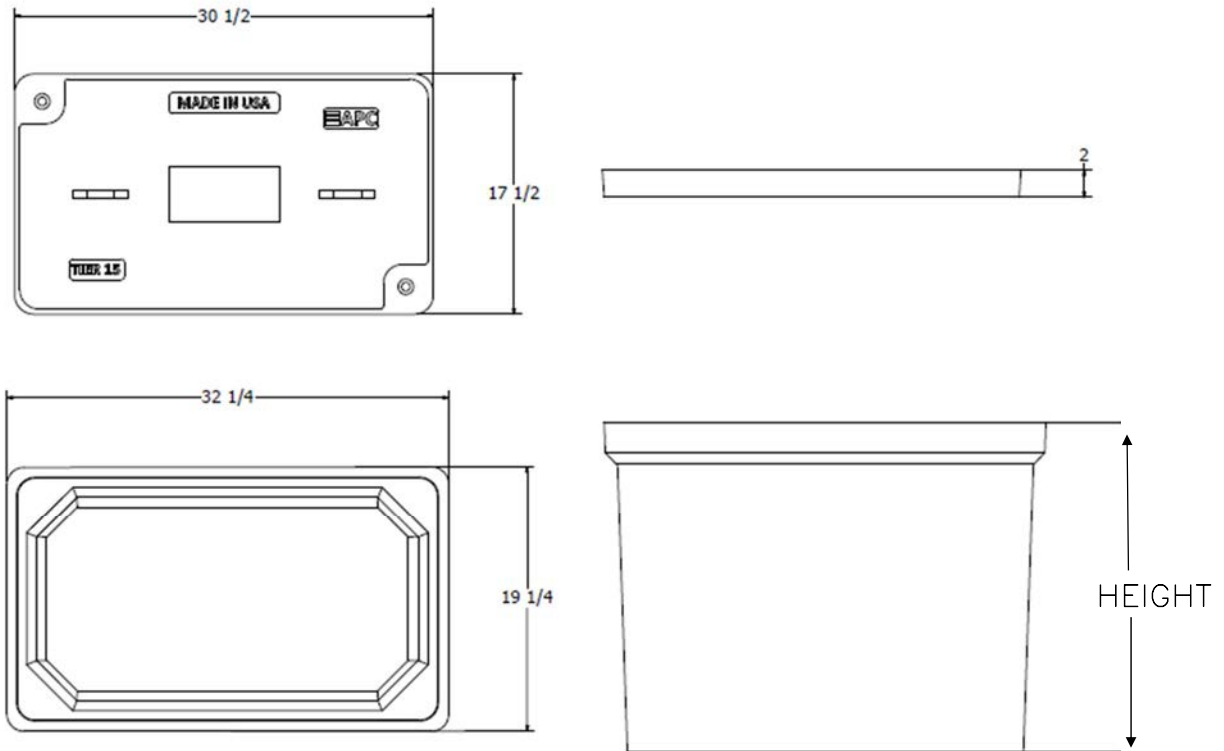

Components	Nominal Size	ANSI Tier	Part Number	Estimated Weight
Replacement Box	17"x30"x12"	Tier 22	P173012B22	66 lbs.
Replacement Box	17"x30"x18"	Tier 22	P173018B22	100 lbs.
Replacement Box	17"x30"x24"	Tier 22	P173024B22	120 lbs.
Replacement Box	17"x30"x30"	Tier 22	P173030B22	145 lbs.
Replacement Lids - T15	17"x30"	Tier 15	Various	72 lbs.
Replacement Lids - T22	17"x30"	Tier 22	Various	81 lbs.

Bolt options



Machine Thread



Auger Thread



33"x60" PC UNIT, 2PC TIER 15/22
36" HEIGHT



AMERICAN POLYMER COMPANY

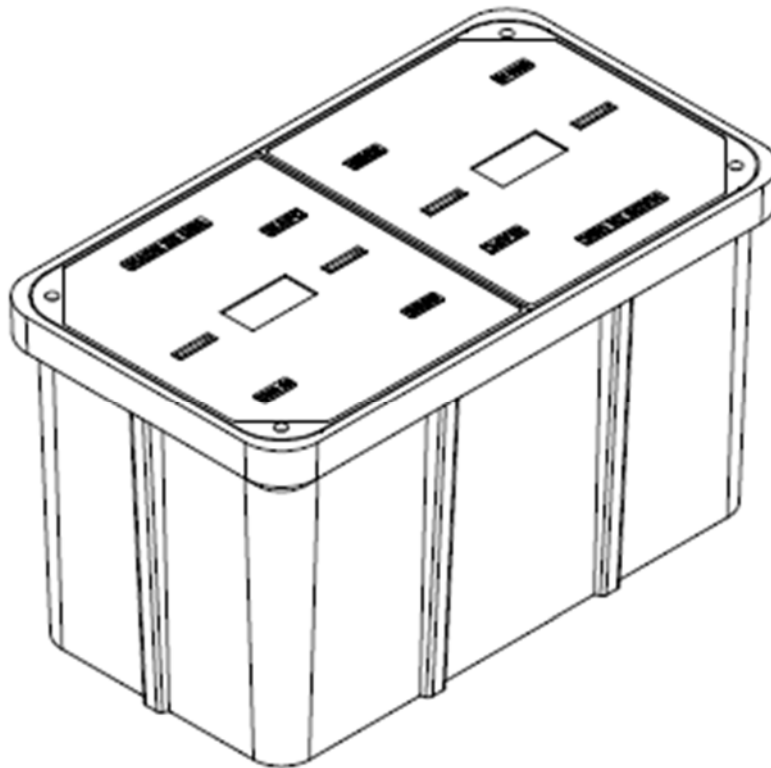

Description	Nominal Size	ANSI Tier	Part Number	Estimated Weight
PC Unit - TIER 15	33"x60"x36"	Tier 15	P336036U15...	930 lbs.
PC Unit - TIER 22	33"x60"x36"	Tier 22	P336036U22...	1030 lbs.



33"x60" PC UNIT, 2PC TIER 15/22

36" HEIGHT



AMERICAN POLYMER COMPANY

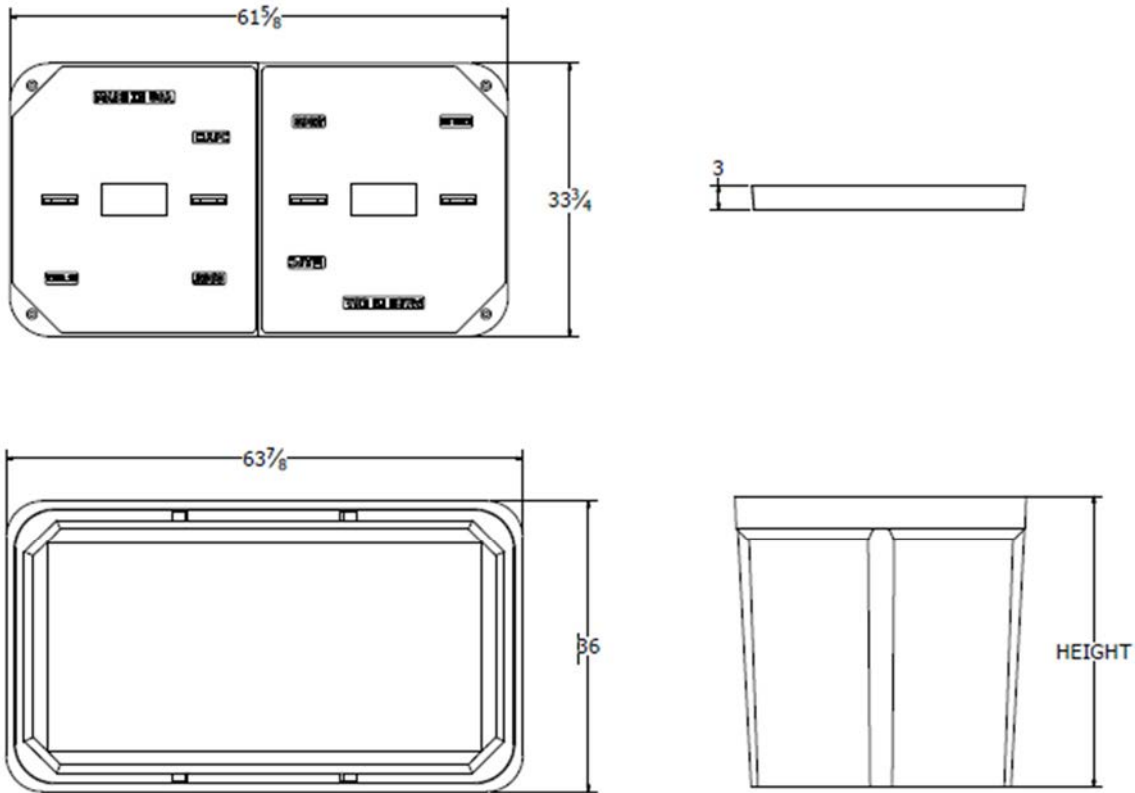

Components	Nominal Size	ANSI Tier	Part Number	Estimated Weight
Replacement Box	33"x60"x36"	Tier 22	P336036B22	530 lbs.
Replacement Lids - T15	33"x60" (half)	Tier 15	Various	200 lbs.
Replacement Lids - T22	33"x60" (half)	Tier 22	Various	250 lbs.

Bolt options

Hex Head



Machine Thread



Penta Head



Auger Thread



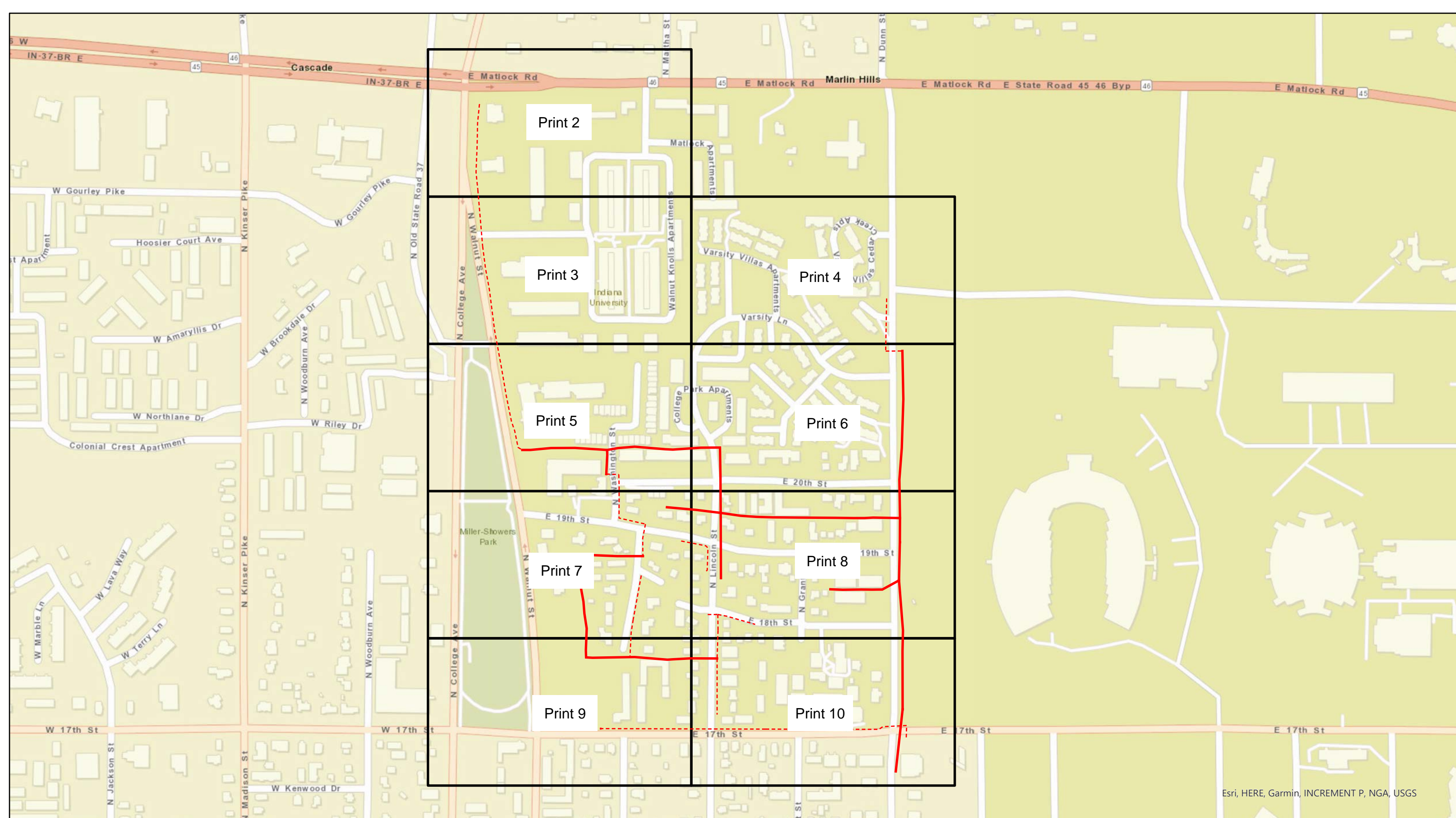

Esri, HERE, Garmin, INCREMENT P, NGA, USGS



Legend BLN01a-F02_E 19th St

- Proposed Strand
- - - Proposed Conduit
- Grids

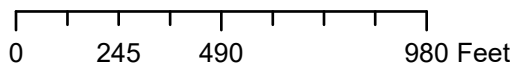

City of Bloomington, IN Permit:
Design View

INI	BY	DATE	DESCRIPTION



N Old State Road 37

N Martha St

E Matlock Rd

N Walnut St

Continues into
INDOT permit

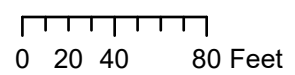

Legend

- Poles
- Risers
- Sidewalk
- Vaults
- Address
- Bloomington_Parcels
- Overhead Strand
- Anchor
- Conduit
- Grids

All Flowerpots 12" DIA



City of Bloomington, IN Permit:
Design View

INI	BY	DATE	DESCRIPTION

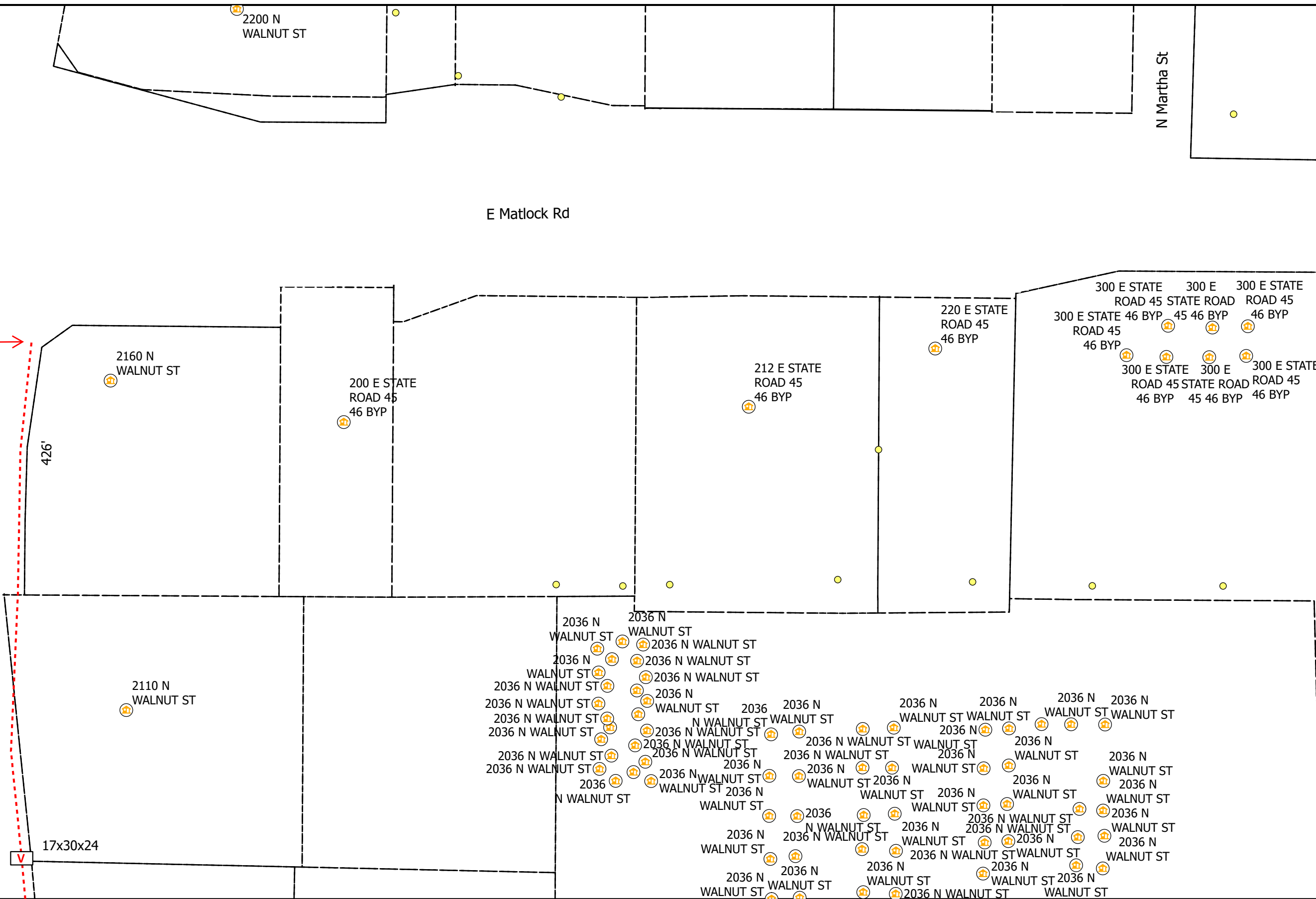

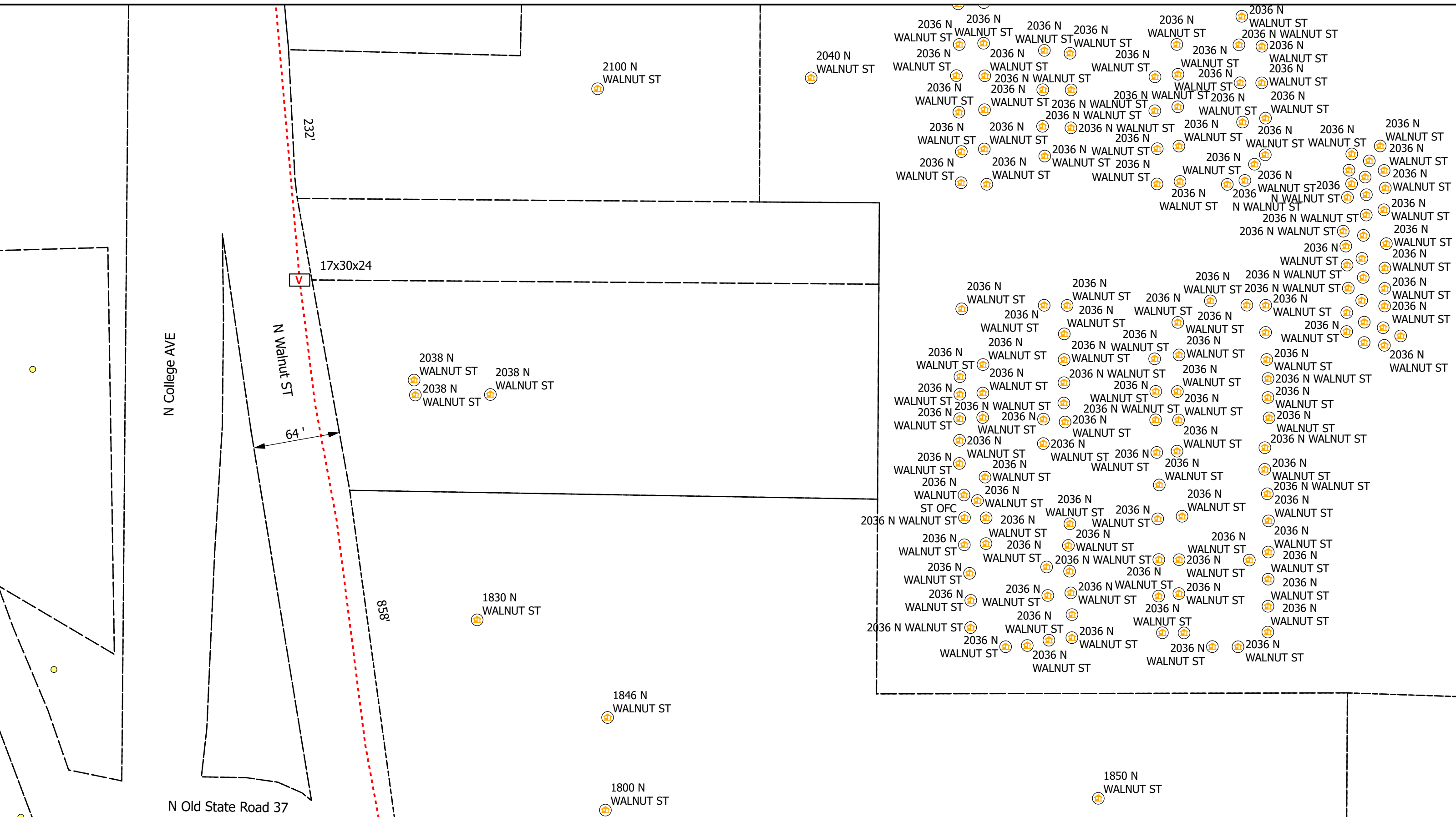

0 20 40 80 Feet

Legend

- Poles
- V Vaults
- Overhead Strand
- - - Conduit
- Ⓡ Risers
- Ⓜ Address
- Y Anchor
- └ Sidewalk
- Bloomington_Parcels
- Grids

All Flowerpots 12" DIA

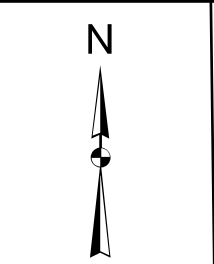

City of Bloomington, IN Permit:
Design View

INI	BY	DATE	DESCRIPTION

Print 3 of 10

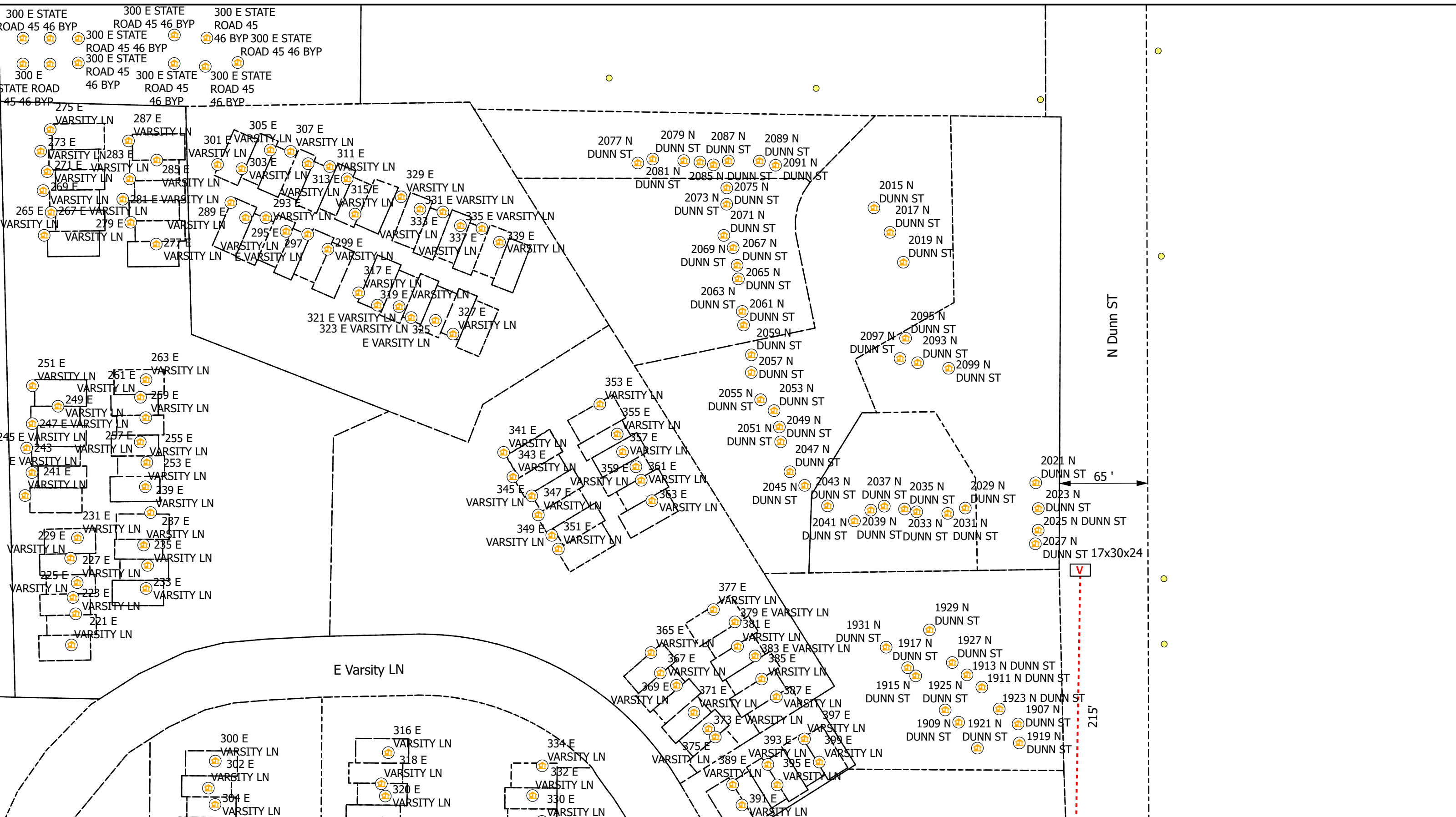

0 20 40 80 Feet

Legend

- Poles
- Ⓡ Risers
- ↖ Sidewalk
- V Vaults
- Ⓜ Address
- Bloomington_Parcels
- Overhead Strand
- Y Anchor
- - - Conduit
- Grids

All Flowerpots 12" DIA

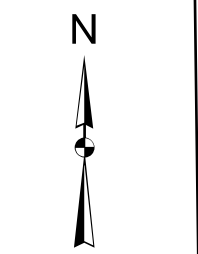

City of Bloomington, IN Permit:
Design View

INI	BY	DATE	DESCRIPTION

Print 4 of 10

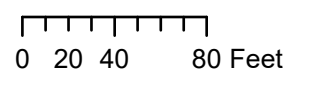
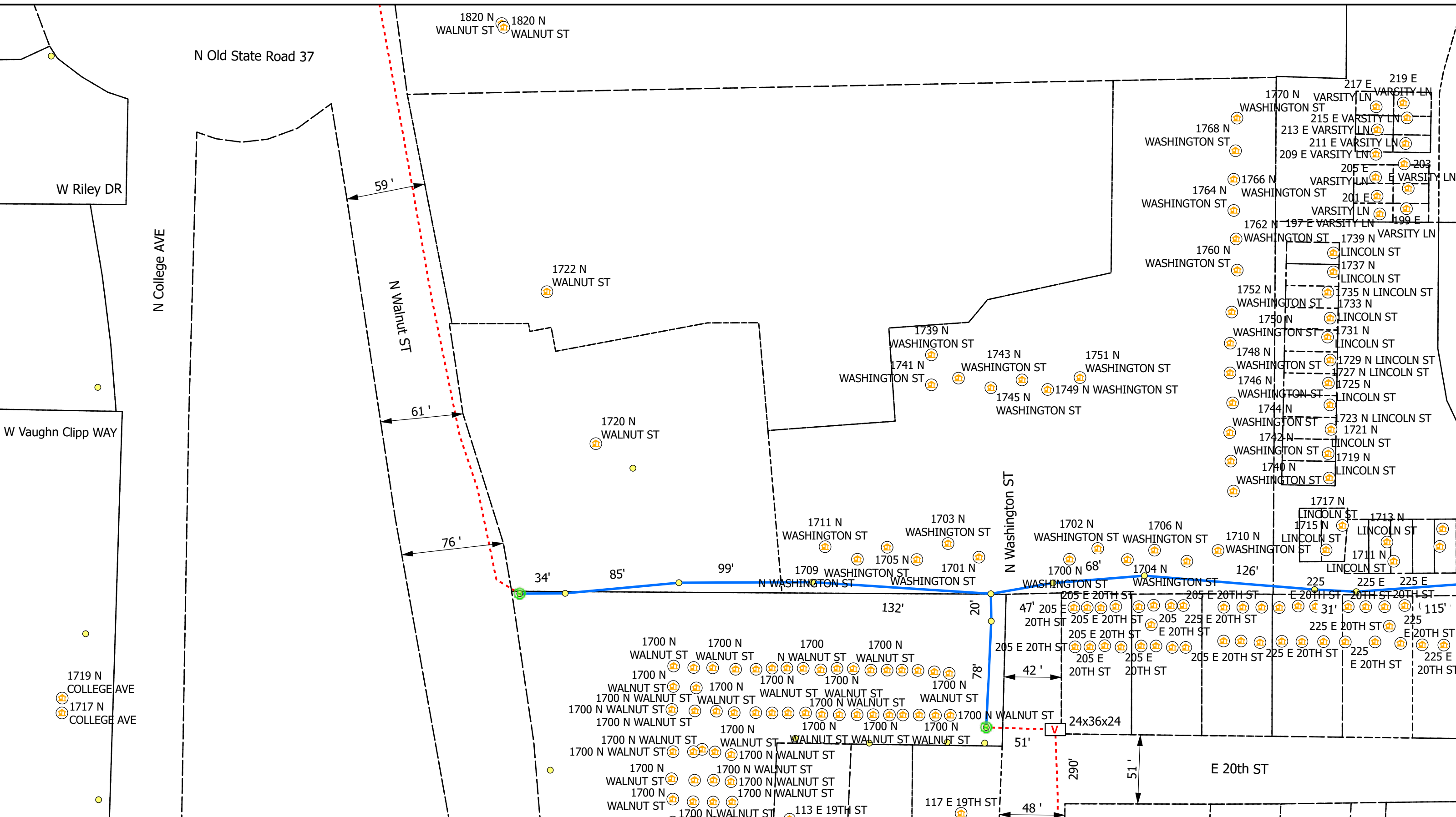

Legend

- Poles
- V Vaults
- Overhead Strand
- Conduit
- R Risers
- 🏠 Address
- Y Anchor
- ↖ Sidewalk
- Bloomington_Parcels
- Grids

All Flowerpots 12" DIA



City of Bloomington, IN Permit:
Design View

INI	BY	DATE	DESCRIPTION



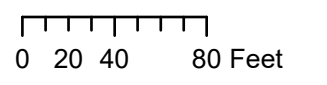
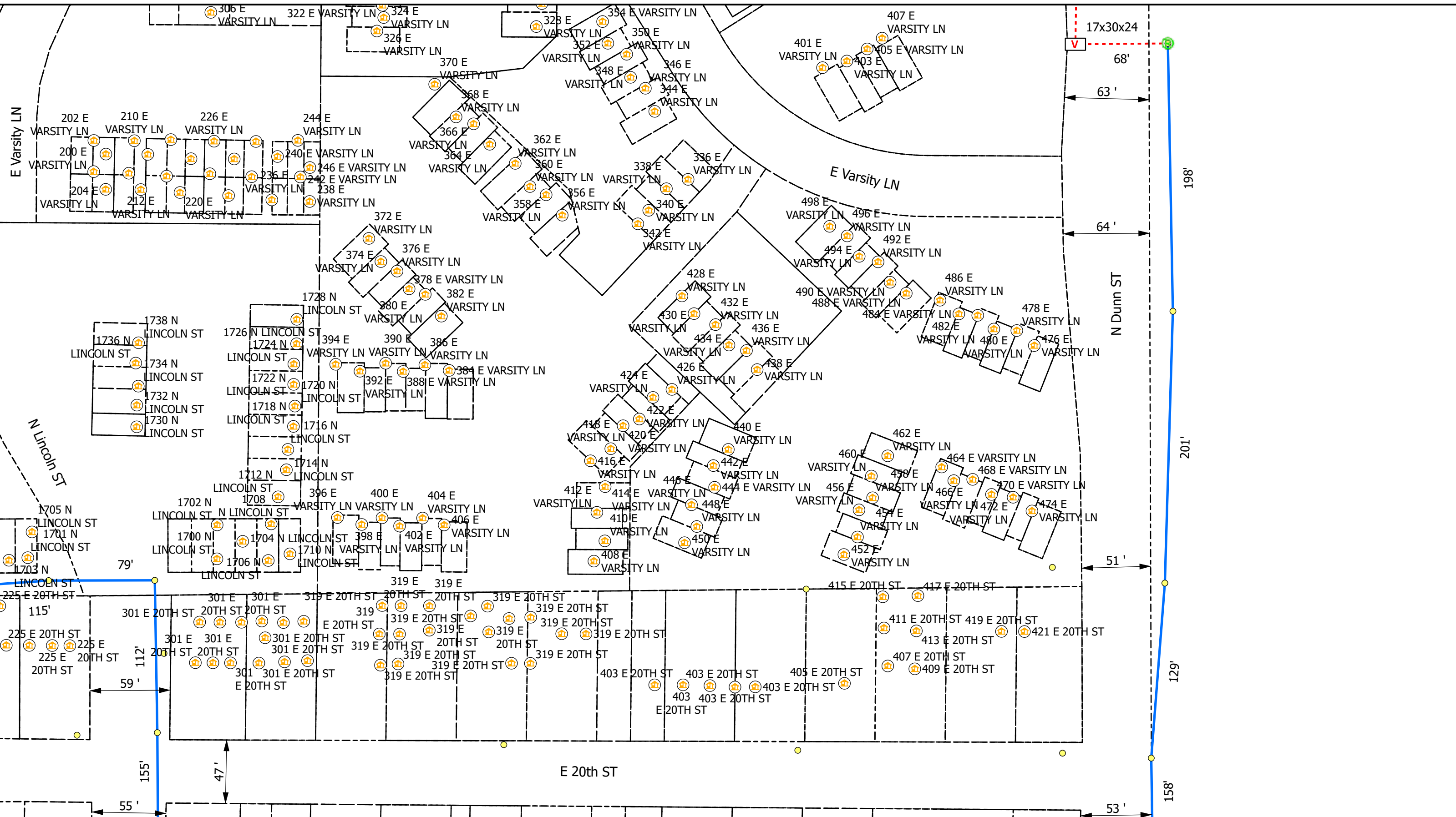

Legend

- Poles
- Risers
- Vaults
- Overhead Strand
- Conduit
- Address
- Anchor
- Sidewalk
- Bloomington_Parcels
- Grids

All Flowerpots 12" DIA



City of Bloomington, IN Permit:
Design View

INI	BY	DATE	DESCRIPTION



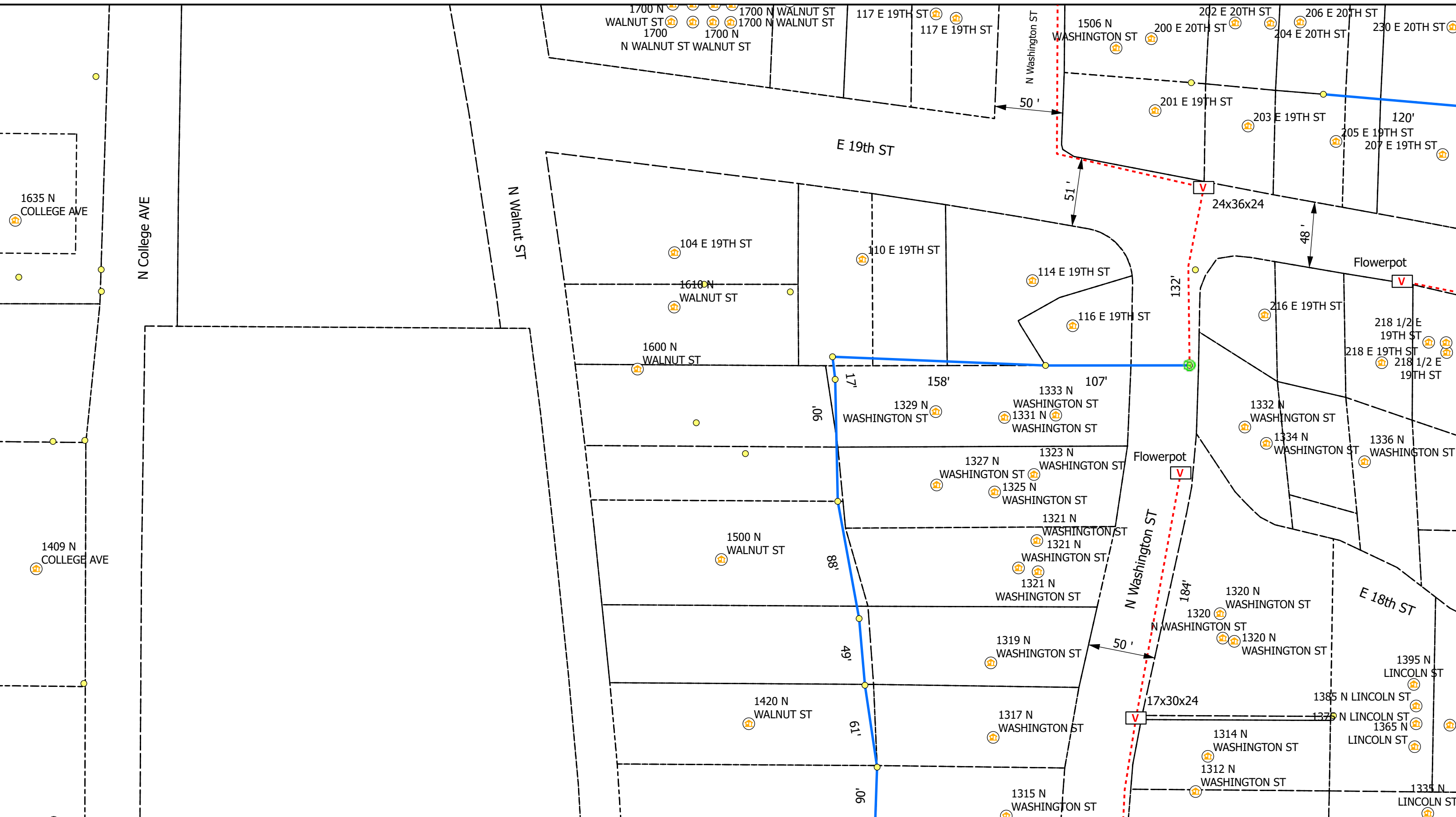

- Legend**
- Poles
 - V Vaults
 - Overhead Strand
 - Conduit
 - Ⓡ Risers
 - Ⓜ Address
 - Y Anchor
 - ↖ Sidewalk
 - Bloomington_Parcels
 - Grids

All Flowerpots 12" DIA



City of Bloomington, IN Permit:
Design View

INI	BY	DATE	DESCRIPTION



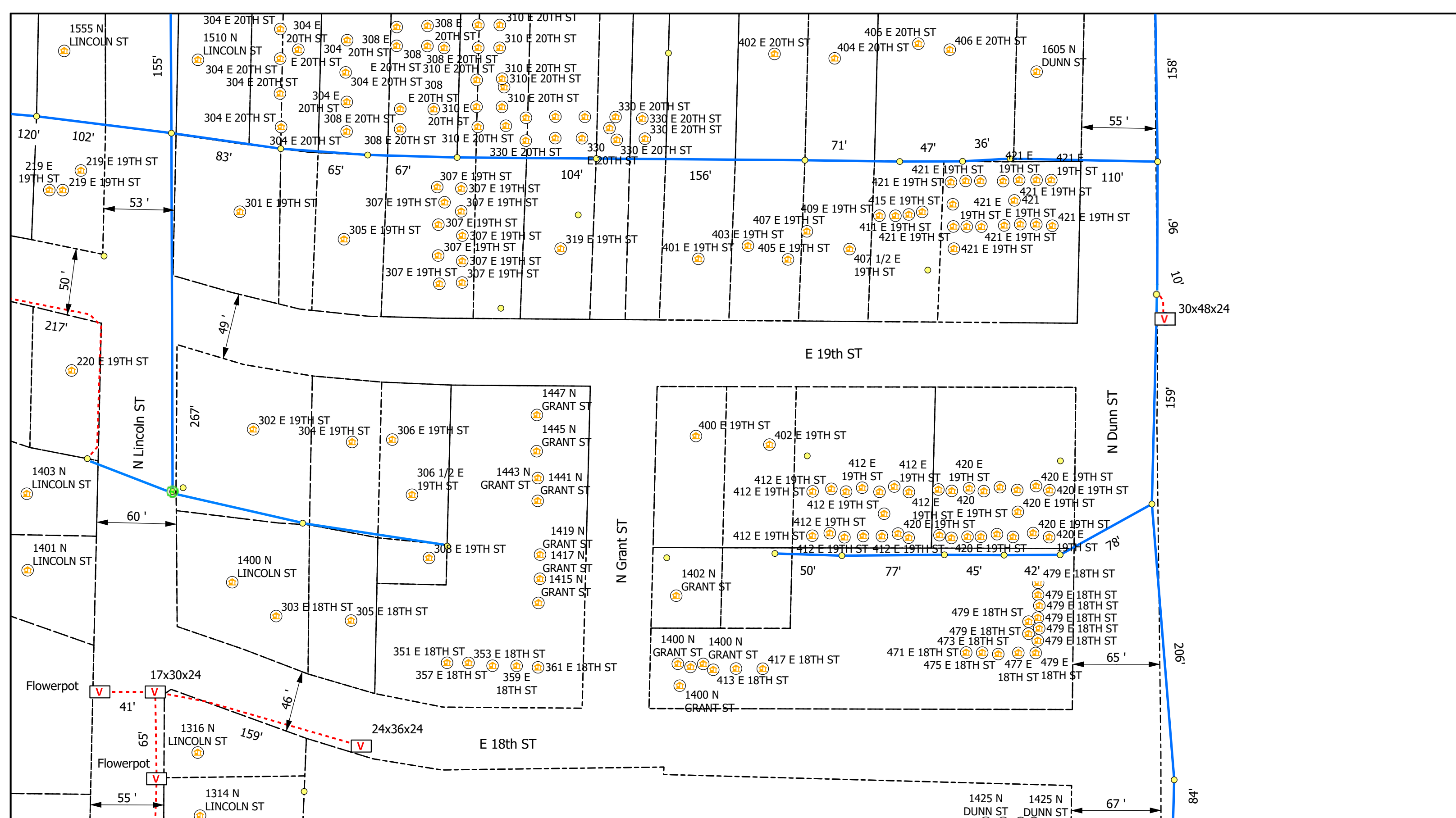

Legend

- Poles
- Risers
- Sidewalk
- Vaults
- Address
- Bloomington_Parcels
- Overhead Strand
- Anchor
- Grids
- Conduit

All Flowerpots 12" DIA



City of Bloomington, IN Permit:
Design View

INI	BY	DATE	DESCRIPTION



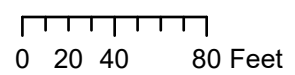
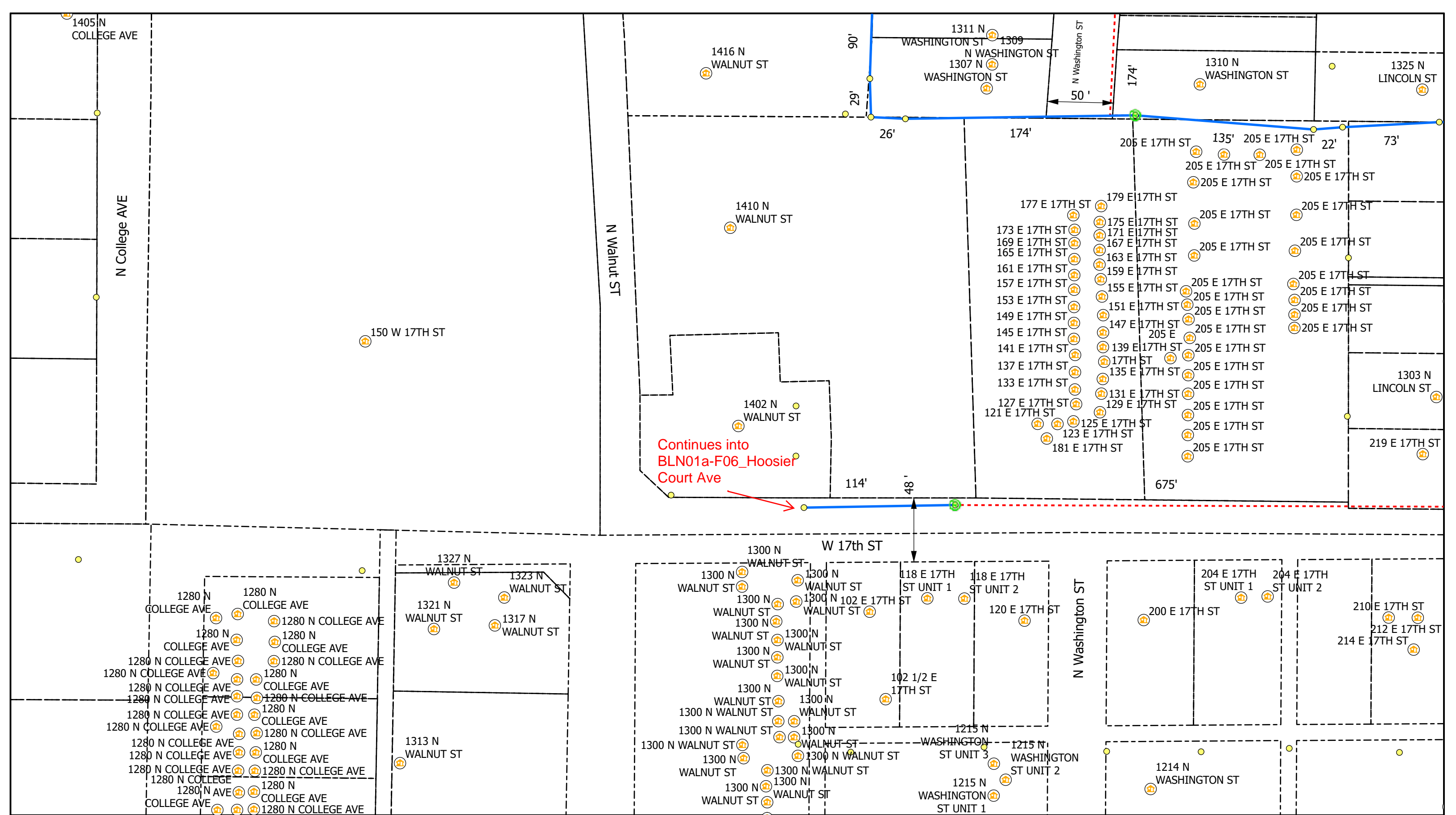

Legend

- Poles
- Ⓡ Risers
- ⏏ Sidewalk
- V Vaults
- 🏠 Address
- Bloomington_Parcels
- Overhead Strand
- Conduit
- Y Anchor
- Grids

All Flowerpots 12" DIA



City of Bloomington, IN Permit:
Design View

INI	BY	DATE	DESCRIPTION



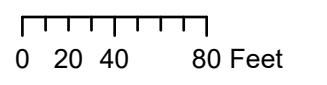
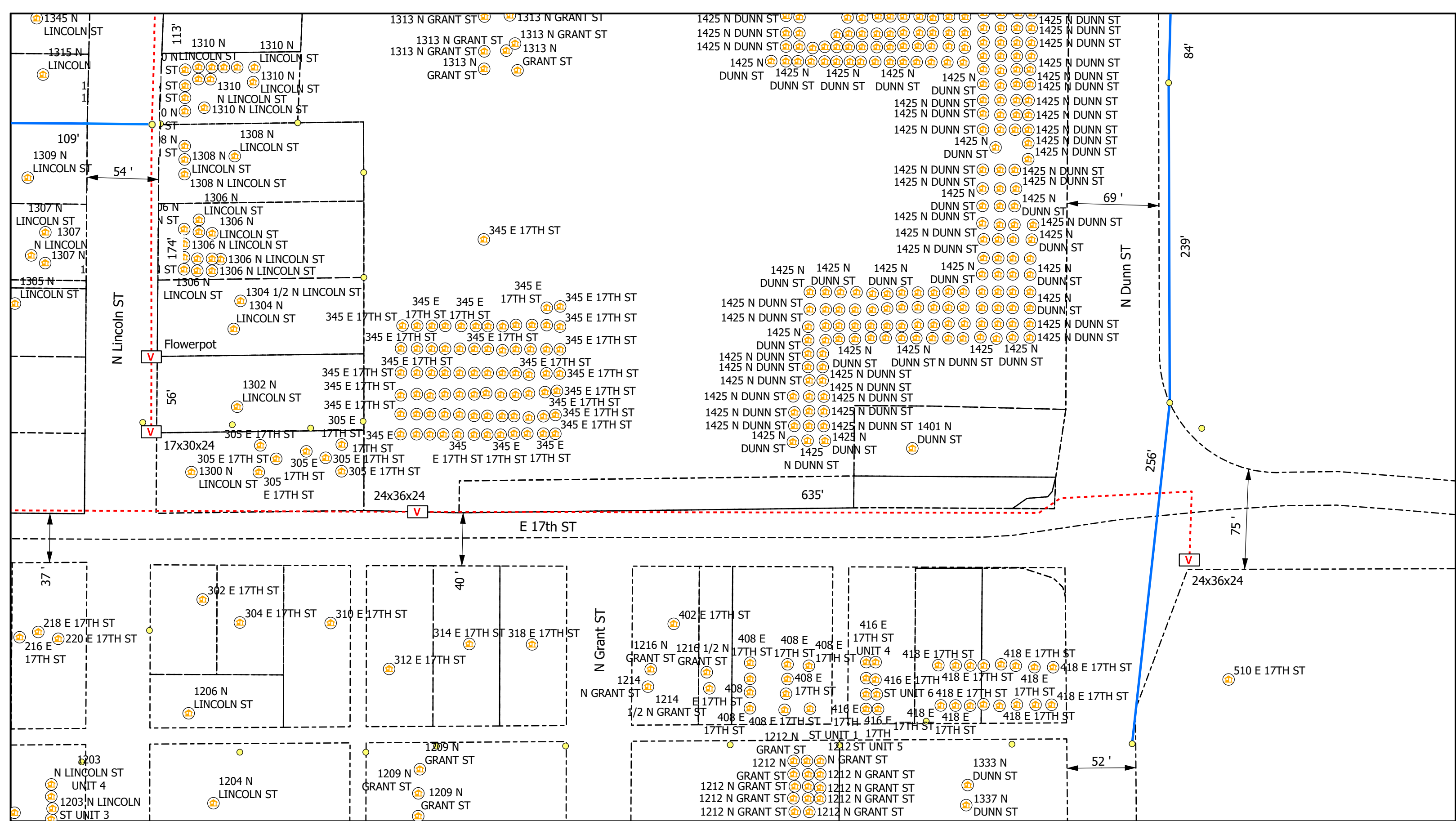

Legend

- Poles
- Risers
- Address
- Y Anchor
- V Vaults
- Overhead Strand
- Conduit
- ↖ Sidewalk
- Bloomington_Parcels
- Grids

All Flowerpots 12" DIA



City of Bloomington, IN Permit:
Design View

INI	BY	DATE	DESCRIPTION



Carlton® PV-Mold® Nonmetallic Pole Riser System

Carlton PV-Mold is a nonmetallic pole riser system designed to protect communications power cable installed on poles.

Features:

- Meets or exceeds requirements outlined in the National Electric Safety Code (NESC).
- Designed in accordance with NEMA TC-19 specifications.
- Ultraviolet, cold temperature and corrosive atmosphere resistant.
- Schedule 40 wall meets Schedule 80 PVC conduit impact requirements per NEMA TC-19.
- No grounding required.
- Belled end fits over each added section or conduit.
- Flame retardant.
- Requires no maintenance.
- PV-Mold acts as an insulator against electrical shock.
- Interchangeable parts and accessories to match the needs of specific requirements.



Steel U-Guard requires grounding strapping and does not have belled ends.



PV-Mold has belled ends, flanged design and does not require grounding.

Flanged Overall Length 10 Feet, Including Bell

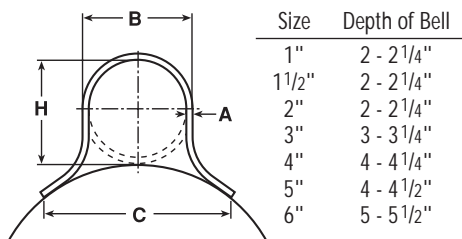

Slots are 1/2" from side to side, and allow for expansion and contraction.

Slot Dimensions: for sizes 2" through 6" are 5/16" wide, 3/4" long.

Slot Dimensions: for 1" and 1 1/2" are 3/16" wide, 3/4" long.

Slot Spacing: 18" from center, beginning 6" from end.



Standard Duty

Part No.	Size	Std. Ctn. Qty.	Std. Ctn. Wt. (lbs.)	Dimensions				Actual Impact @ 0°C 20 Pound Top
				A	B	C	H	
59208N	1"	294	1059	0.100"	1 5/8"	2 3/8"	1 5/8"	40 Ft.-Lbs.
59211N	2"	136	726	0.100"	2 3/8"	4 1/2"	2 3/8"	100 Ft.-Lbs.
59211X (5' length)	2"	136	363	0.100"	2 3/8"	4 1/2"	2 3/8"	100 Ft.-Lbs.
59213N	3"	66	761	0.150"	3 1/2"	6"	3 1/2"	110 Ft.-Lbs.
59213X (5' length)	3"	66	381	0.150"	3 1/2"	6"	3 1/2"	100 Ft.-Lbs.
59215N	4"	65	910	0.150"	4 1/2"	6 1/2"	4 1/2"	110 Ft.-Lbs.
59216N	5"	30	515	0.150"	5 1/2"	7 1/2"	5 1/2"	110 Ft.-Lbs.

Heavy Duty Schedule 40

59010N	1 1/2"	200	1142	0.145"	1 29/32"	3 1/2"	1 29/32"	100 Ft.-Lbs.
59011N	2"	136	1214	0.154"	2 3/8"	4 1/2"	2 3/8"	150 Ft.-Lbs.
59013N	3"	66	937	0.216"	3 1/2"	6"	3 9/32"	150 Ft.-Lbs.
59015N	4"	65	1621	0.237"	4 1/2"	6 1/2"	4 1/2"	260 Ft.-Lbs.
59015X (5' length)	4"	65	707	0.237"	4 1/2"	6 1/2"	4 1/2"	260 Ft.-Lbs.
59016N	5"	30	870	0.258"	5 1/2"	7 1/2"	5 1/2"	260 Ft.-Lbs.
59017N	6"	30	1160	0.280"	6 5/8"	8 3/4"	6 5/8"	260 Ft.-Lbs.

Extra Heavy Duty Schedule 80

59411N	2"	136	1549	0.218"	2 3/8"	4 1/2"	2 3/8"	300 Ft.-Lbs.
59413N	3"	66	1495	0.030"	3 1/2"	6"	3 1/2"	525 Ft.-Lbs.

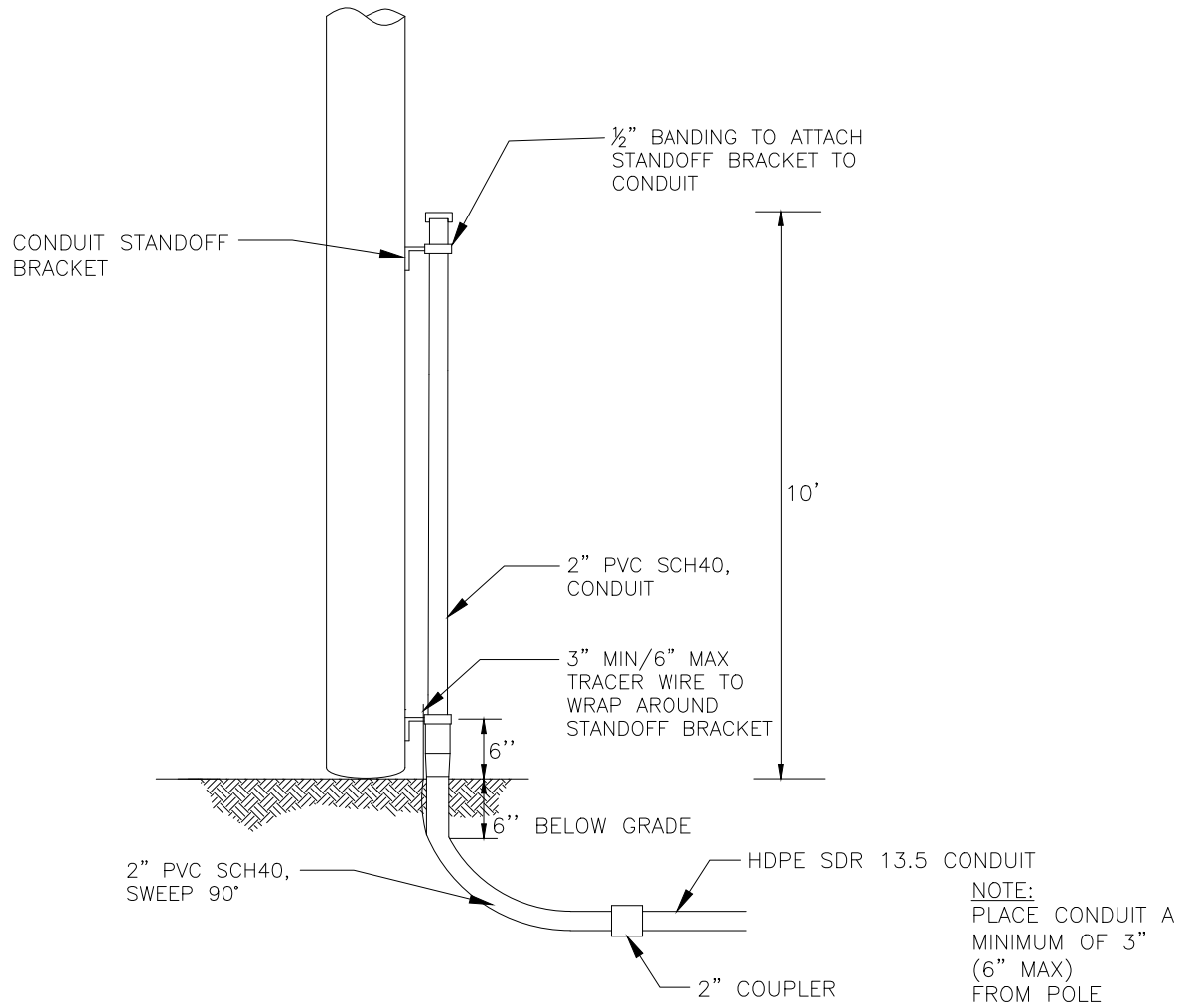

DESCRIPTION	QTY	MANUFACTURER (PREFERRED)	PART #
SCREW, LAG, 1/2" x 4-1/2"	10		
HDPE SDR 13.5 CONDUIT, VARIOUS SIZES	N/A		
2" PVC SCH40, RISER PIPE	1		
#12 TRACER WIRE	N/A		
2" PVC SCH40, SWEEP, 90 DEG	1		
CONDUIT STANDOFF BRACKET	VARIES		
CONDUIT STRAP KIT	VARIES		
2" COUPLER	1		



TYPICAL RISER
CONDUIT
WOOD POLE

(R2-W)

CONCEPTUAL SIDE VIEW

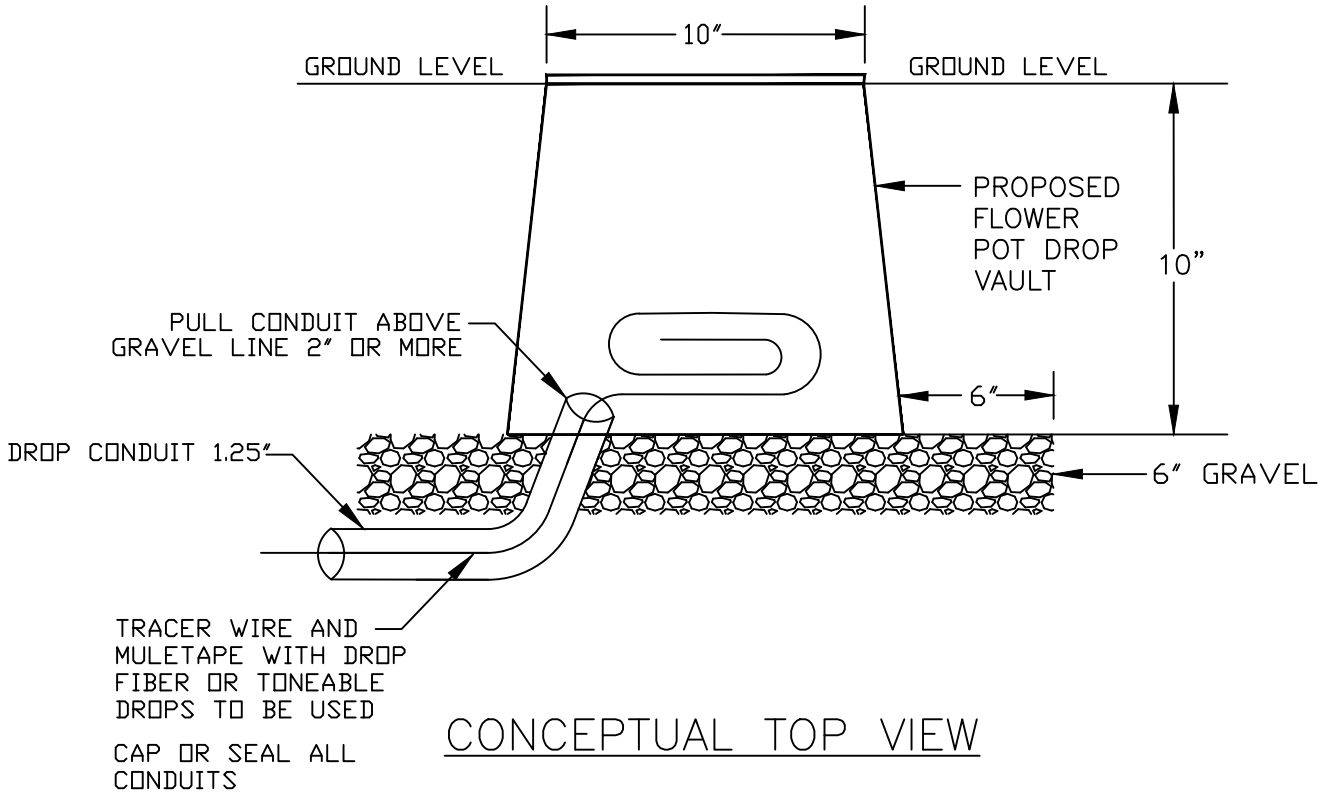

CONCEPTUAL TOP VIEW

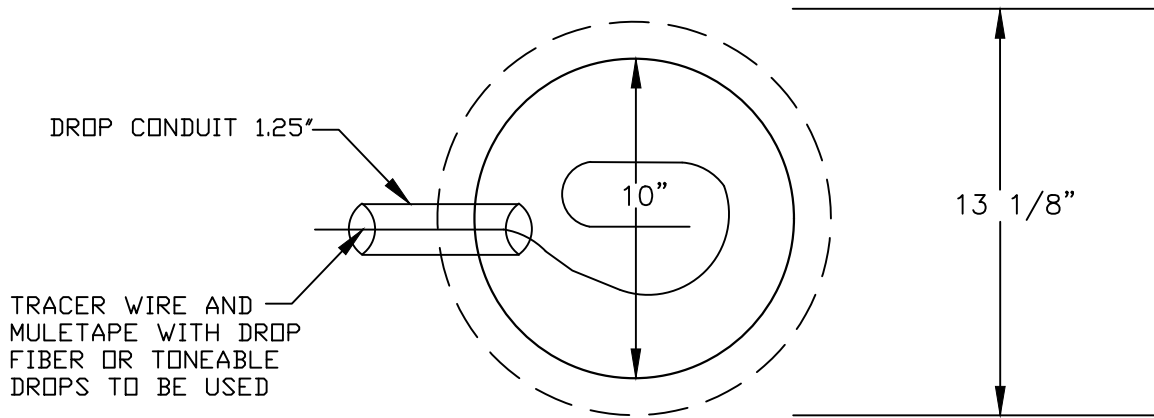

FLOWER POT

30"x48" PC UNIT, 2PC TIER 15/22
 18", 24", and 36" HEIGHT



AMERICAN POLYMER COMPANY

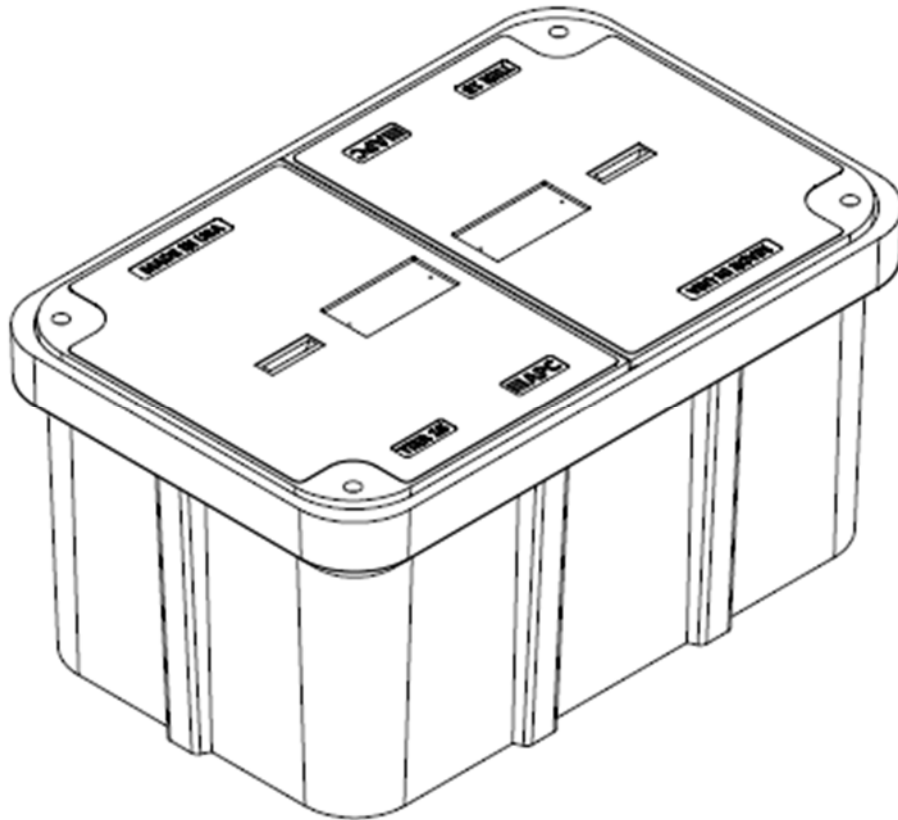

Description	Nominal Size	ANSI Tier	Part Number	Estimated Weight
PC Unit – TIER 15	30"x48"x18"	Tier 15	P304818HU15...	460 lbs.
PC Unit – TIER 22	30"x48"x18"	Tier 22	P304818HU22...	525 lbs.
PC Unit – TIER 15	30"x48"x24"	Tier 15	P304824HU15...	510 lbs.
PC Unit – TIER 22	30"x48"x24"	Tier 22	P304824HU22...	575 lbs.
PC Unit – TIER 15	30"x48"x36"	Tier 15	P304836HU15...	615 lbs.
PC Unit – TIER 22	30"x48"x36"	Tier 22	P304836HU22...	680 lbs.



30"x48" PC UNIT, 2PC TIER 15/22

18", 24", and 36" HEIGHT



AMERICAN POLYMER COMPANY

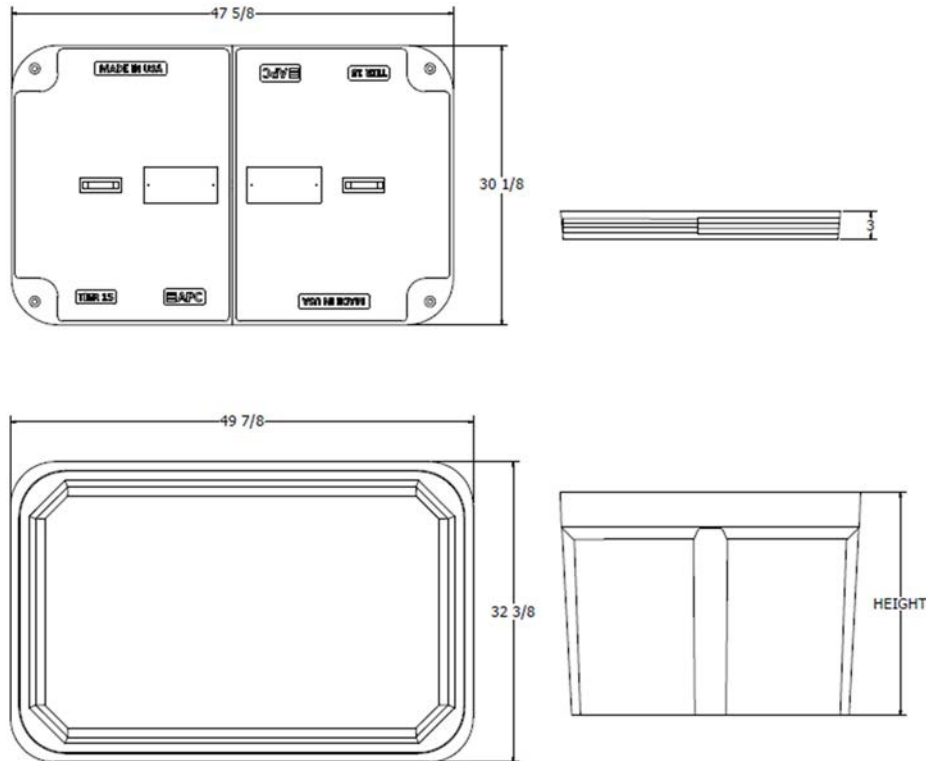

Components	Nominal Size	ANSI Tier	Part Number	Estimated Weight
Replacement Box	30"x48"x18"	Tier 22	P304818B22	185 lbs.
Replacement Box	30"x48"x24"	Tier 22	P304824B22	235 lbs.
Replacement Box	30"x48"x36"	Tier 22	P304836B22	340 lbs.
Replacement Lids - T15	30"x48" (half)	Tier 15	Various	150 lbs.
Replacement Lids - T22	30"x48" (half)	Tier 22	Various	170 lbs.

Bolt options

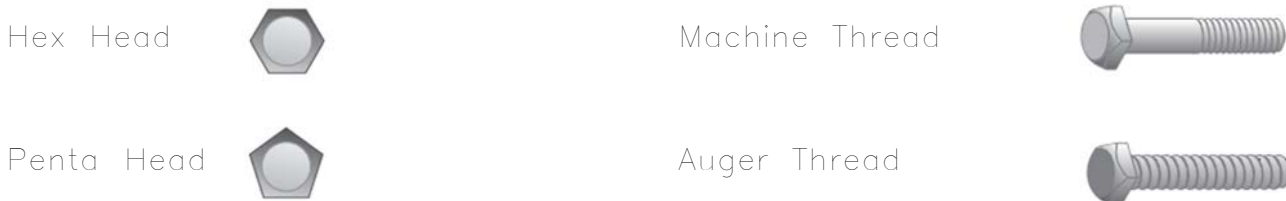

24"x36" PC UNIT, TIER 15/22
 18", 24", 30", and 36" HEIGHT



AMERICAN POLYMER COMPANY

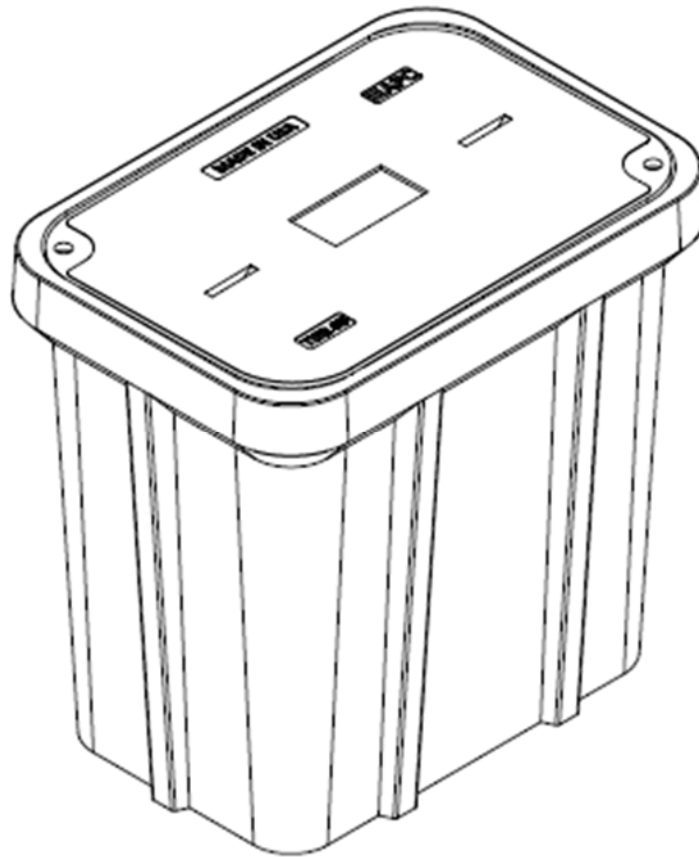

Description	Nominal Size	ANSI Tier	Part Number	Estimated Weight
PC Unit – TIER 15	24x36"x18"	Tier 15	P243618U15...	335 lbs.
PC Unit – TIER 22	24x36"x18"	Tier 22	P243618U22...	355 lbs.
PC Unit – TIER 15	24x36"x24"	Tier 15	P243624U15...	365 lbs.
PC Unit – TIER 22	24x36"x24"	Tier 22	P243624U22...	385 lbs.
PC Unit – TIER 15	24x36"x30"	Tier 15	P243630U15...	395 lbs.
PC Unit – TIER 22	24x36"x30"	Tier 22	P243630U22...	415 lbs.
PC Unit – TIER 15	24x36"x36"	Tier 15	P243636U15...	425 lbs.
PC Unit – TIER 22	24x36"x36"	Tier 22	P243636U22...	445 lbs.



24"x36" PC UNIT, TIER 15/22

18", 24", 30", and 36" HEIGHT



AMERICAN POLYMER COMPANY

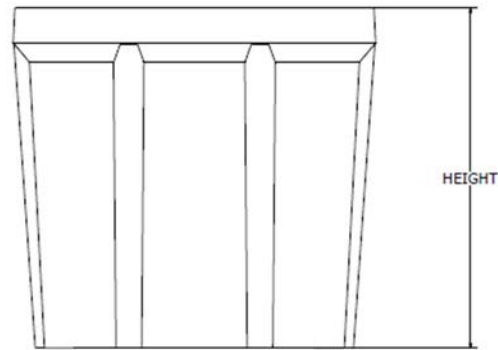
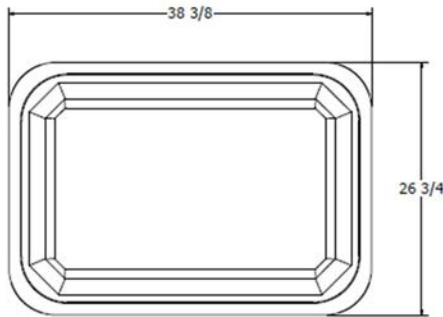
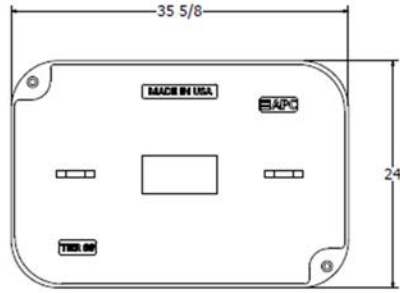

Components	Nominal Size	ANSI Tier	Part Number	Estimated Weight
Replacement Box	24"x36"x18"	Tier 22	P243618B22	165 lbs.
Replacement Box	24"x36"x24"	Tier 22	P243624B22	195 lbs.
Replacement Box	24"x36"x30"	Tier 22	P243630B22	225 lbs.
Replacement Box	24"x36"x36"	Tier 22	P243636B22	255 lbs.
Replacement Lids - T15	24"x36"	Tier 15	Various	170 lbs.
Replacement Lids - T22	24"x36"	Tier 22	Various	190 lbs.

Bolt options

Hex Head



Machine Thread



Penta Head



Auger Thread



17"x30" PC UNIT, TIER 15/22

12", 18", 24", and 30" HEIGHT



AMERICAN POLYMER COMPANY

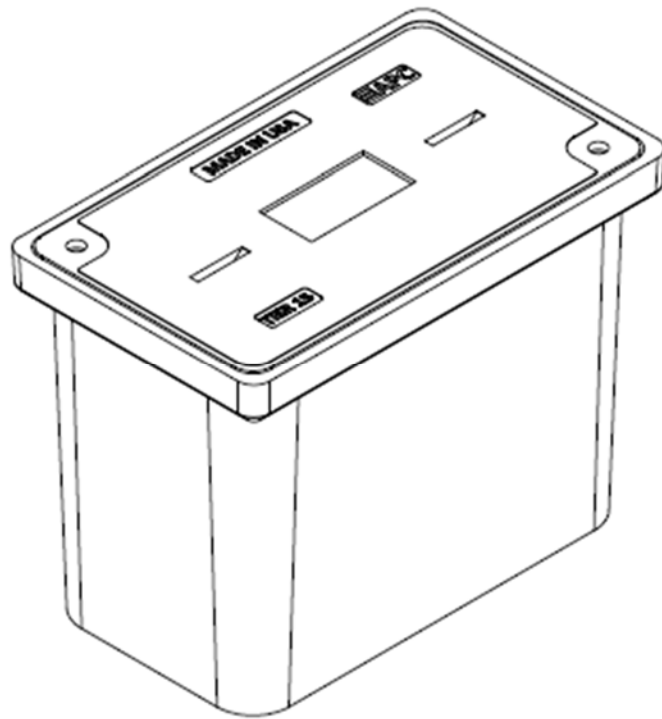

Description	Nominal Size	ANSI Tier	Part Number	Estimated Weight
PC Unit - TIER 15	17"x30"x12"	Tier 15	P173012U15...	138 lbs.
PC Unit - TIER 22	17"x30"x12"	Tier 22	P173012U22...	147 lbs.
PC Unit - TIER 15	17"x30"x18"	Tier 15	P173018U15...	172 lbs.
PC Unit - TIER 22	17"x30"x18"	Tier 22	P173018U22...	181 lbs.
PC Unit - TIER 15	17"x30"x24"	Tier 15	P173024U15...	192 lbs.
PC Unit - TIER 22	17"x30"x24"	Tier 22	P173024U22...	201 lbs.
PC Unit - TIER 15	17"x30"x30"	Tier 15	P173030U15...	217 lbs.
PC Unit - TIER 22	17"x30"x30"	Tier 22	P173030U22...	226 lbs.



17"x30" PC UNIT, TIER 15/22

12", 18", 24", and 30" HEIGHT



AMERICAN POLYMER COMPANY

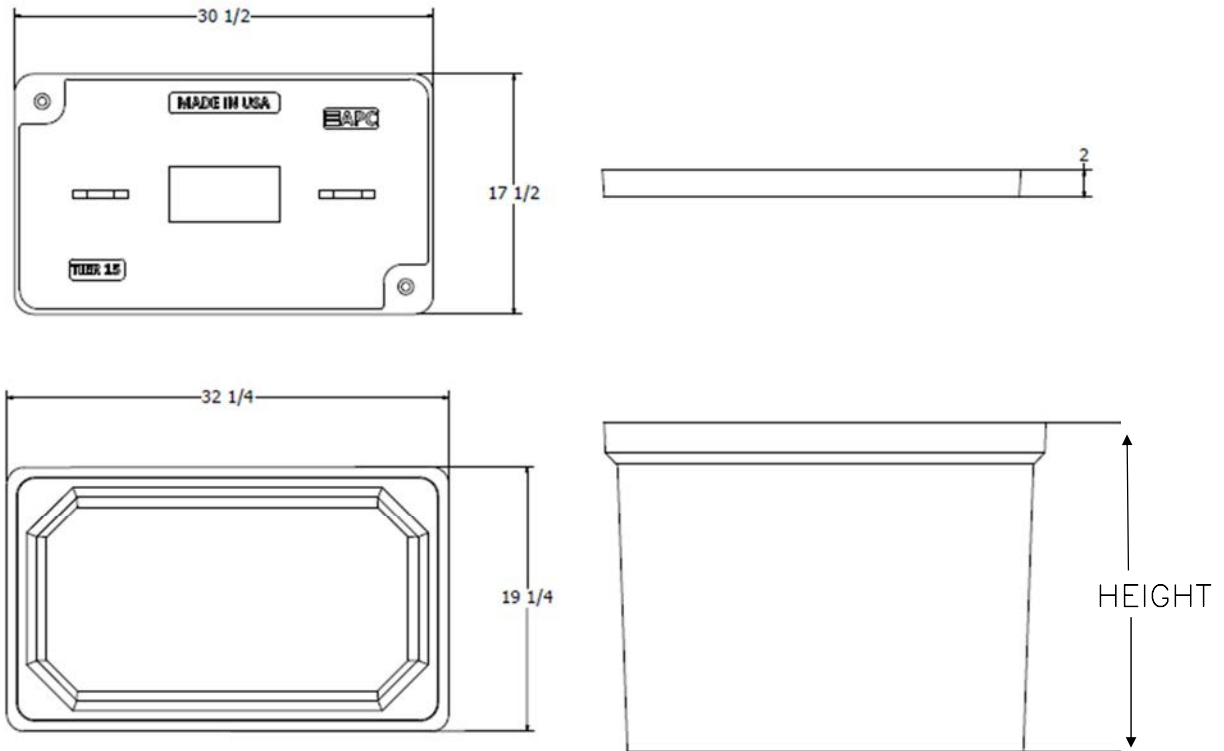

Components	Nominal Size	ANSI Tier	Part Number	Estimated Weight
Replacement Box	17"x30"x12"	Tier 22	P173012B22	66 lbs.
Replacement Box	17"x30"x18"	Tier 22	P173018B22	100 lbs.
Replacement Box	17"x30"x24"	Tier 22	P173024B22	120 lbs.
Replacement Box	17"x30"x30"	Tier 22	P173030B22	145 lbs.
Replacement Lids – T15	17"x30"	Tier 15	Various	72 lbs.
Replacement Lids – T22	17"x30"	Tier 22	Various	81 lbs.

Bolt options



Machine Thread



Auger Thread



33"x60" PC UNIT, 2PC TIER 15/22
36" HEIGHT



AMERICAN POLYMER COMPANY

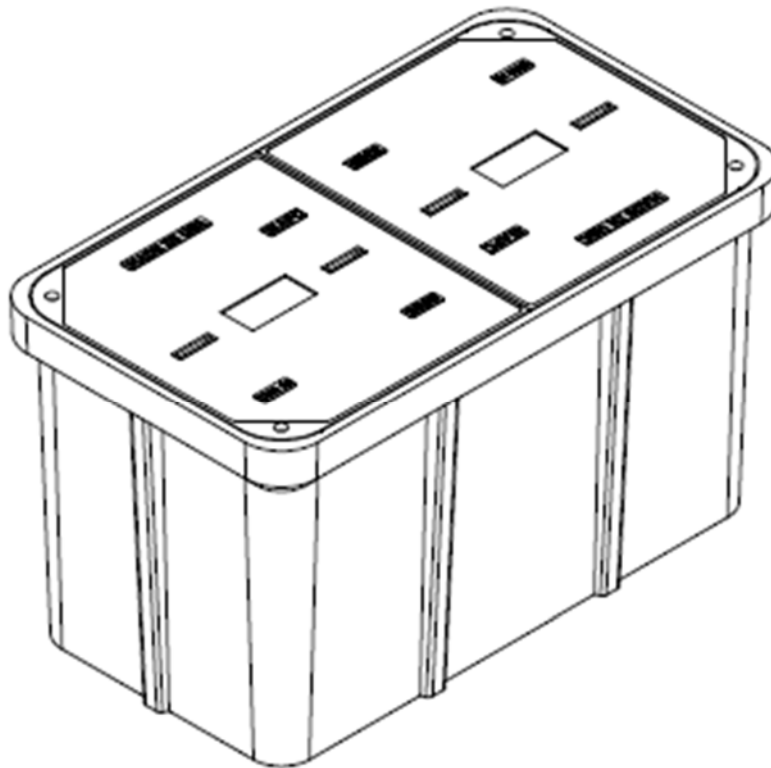

Description	Nominal Size	ANSI Tier	Part Number	Estimated Weight
PC Unit - TIER 15	33"x60"x36"	Tier 15	P336036U15...	930 lbs.
PC Unit - TIER 22	33"x60"x36"	Tier 22	P336036U22...	1030 lbs.



33"x60" PC UNIT, 2PC TIER 15/22

36" HEIGHT



AMERICAN POLYMER COMPANY

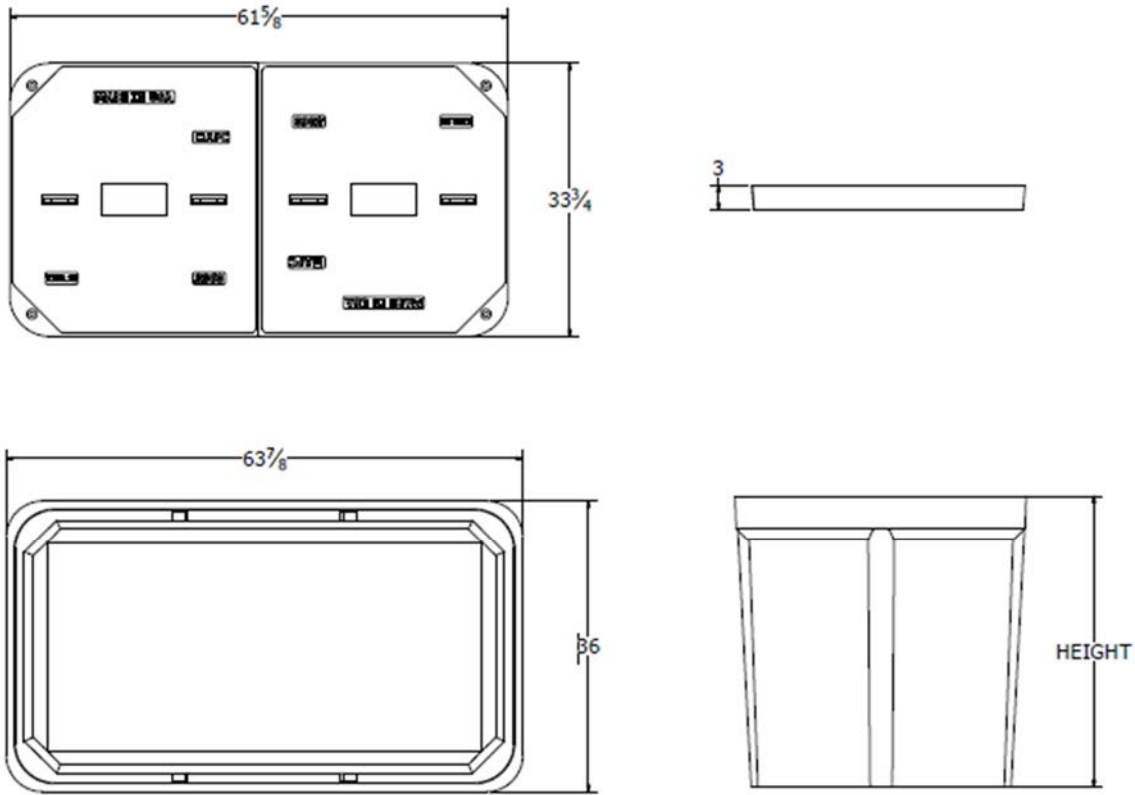

Components	Nominal Size	ANSI Tier	Part Number	Estimated Weight
Replacement Box	33"x60"x36"	Tier 22	P336036B22	530 lbs.
Replacement Lids - T15	33"x60" (half)	Tier 15	Various	200 lbs.
Replacement Lids - T22	33"x60" (half)	Tier 22	Various	250 lbs.

Bolt options

Hex Head



Machine Thread



Penta Head



Auger Thread



Speed (MPH) Prior To Road Work	SIGN SPACING, FT.		Must be Approved by an Engineer				
	Non-Divided Highways	Divided Highways	BUFFER SPACE, FT.	TAPER LENGTH, FT.	CHANNELIZING SPACING, FT.		
	Length	Shoulder (10 ft. Width)	Lane (12 ft. Width)	Through Taper	Through Buffer/Work Area	Through Buffer/Work Area	
0-35	200	200	250	70	245	35	50
40-45	350	500	360	150	540	40	80
50-55	500	1000	495	185	660	50	100
60-70	SA-1000, SB-1500, SC-2640		730	235	840	60	120
Urban Low Speed - 100 FT							

APPROVED/ACCEPTED BY:
ENGINEER, OWNER, or PRIME CONTRACTOR
 Check for Notice to Proceed.

Signature: _____

Company: _____

Date: 10/31/2023 **Project:** BLN01a-F02_E 19th St TCP :
: **Traffic Control Suggestion For:** ATLANTIC ENGINEERING (AEG) :
By: Road Runner Safety Services, Inc. : Nathan

Comments:
Drawing not to scale. Traffic control plan must be approved by an engineer. This is a suggestion only. Road Runners Safety Services, Inc. has no liability for this suggested traffic control plan. Actual placement and spacing of all traffic control devices will depend on field conditions and must conform to MUTCD standards.

- Legend**
- ADA Barricade
 - Channelizer
 - Conduit
 - Flagger (Person)
 - Overhead Strand
 - Sign
 - Vault
 - Work Area

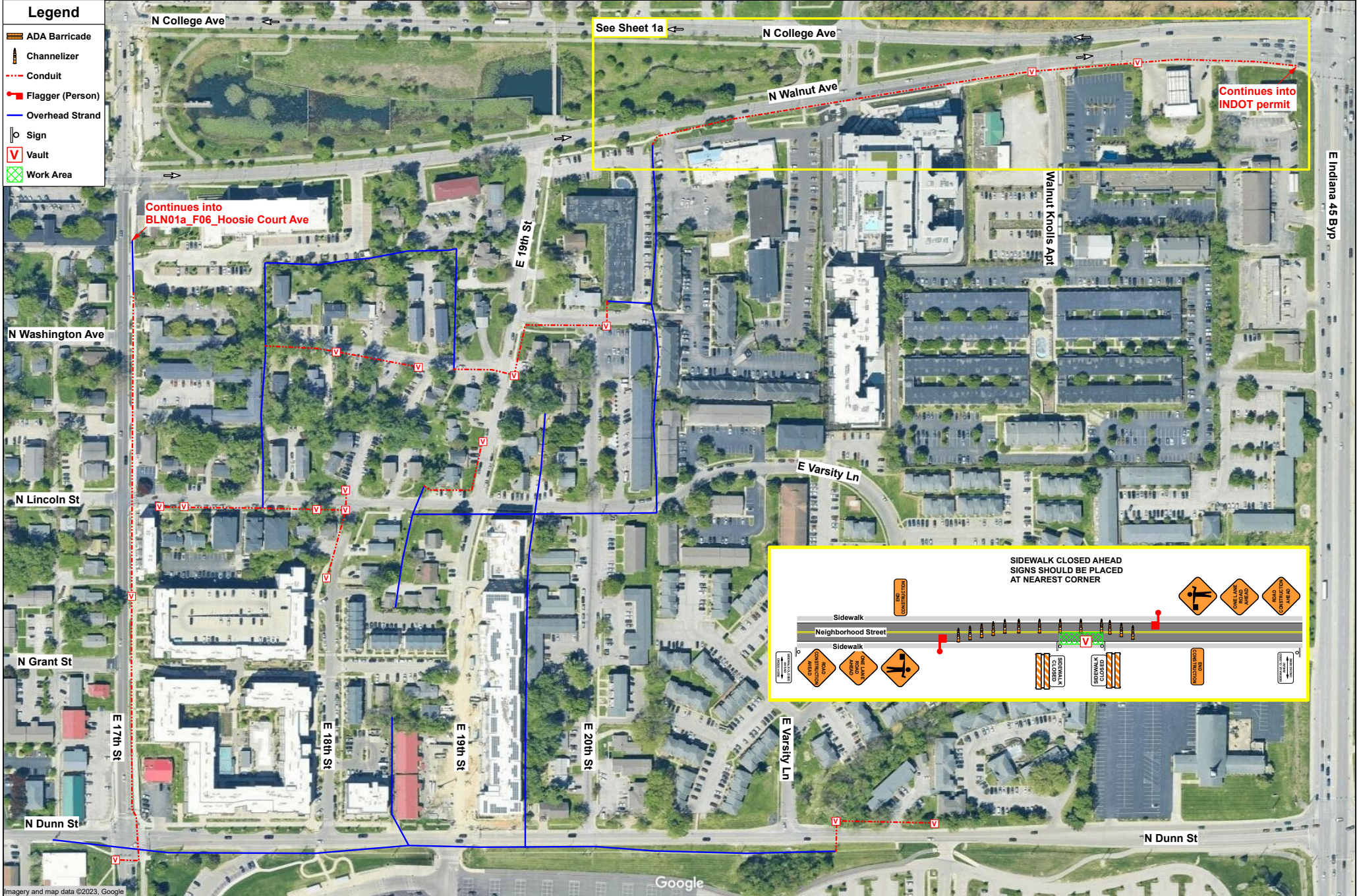

Spacing Charts Based on MUTCD			Must be Approved by an Engineer				
Speed (MPH) Prior To Road Work	SIGN SPACING, FT.		BUFFER SPACE, FT.	TAPER LENGTH, FT.		CHANNELIZING SPACING, FT.	
	Non-Divided Highways	Divided Highways		Shoulder (10 ft Width)	Lane (12 ft Width)	Through Taper	Through Buffer/Work Area
0-35	200	200	250	70	245	35	50
40-45	350	500	360	150	540	40	80
50-55	500	1000	495	185	660	50	100
60-70	SA-1000, SB-1500, SC-2640		730	235	840	60	120
	Urban Low Speed - 100 FT						

APPROVED/ACCEPTED BY:
ENGINEER, OWNER, or PRIME CONTRACTOR
 Check for Notice to Proceed.

Signature: _____

Company: _____

Date: 10/31/2023 **Project:** BLN01a-F02 E 19th St TCP1a :
: **Traffic Control Suggestion For:** ATLANTIC ENGINEERING (AEG) :
By: Road Runner Safety Services, Inc. : Nathan

Comments:
Drawing not to scale. Traffic control plan must be approved by an engineer. This is a suggestion only. Road Runners Safety Services, Inc. has no liability for this suggested traffic control plan. Actual placement and spacing of all traffic control devices will depend on field conditions and must conform to MUTCD standards.



- Manifest**
- 3 x ADA Barricade
 - 1 x Arrow Board
 - 65 x Channelizer
 - 1 x End Construction
 - 2 x Lane Ends (R)
 - 2 x Right Lane Closed Ahead
 - 5 x Road Construction Ahead
 - 1 x Sidewalk Closed
 - 1 x Sidewalk Closed Ahead Cross Here (L)
 - 1 x Sidewalk Closed Cross Here
 - 1 x Sidewalk Closed Cross Here (R)

- Legend**
- ADA Barricade
 - Arrow Board
 - Channelizer
 - Conduit
 - Vault
 - Work Area



Sheet 1a

Google Earth

Spacing Charts Based on MUTCD								Must be Approved by an Engineer	
Speed (MPH) Prior To Road Work	SIGN SPACING, FT.		BUFFER SPACE, FT.	TAPER LENGTH, FT.		CHANNELIZING SPACING, FT.			
	Non-Divided Highways	Divided Highways	Length	Shoulder (10 ft Width)	Lane (12 ft Width)	Through Taper	Through Buffer/Work Area		
0-35	200	200	250	70	245	35	50		
40-45	350	500	360	150	540	40	80		
50-55	500	1000	495	185	660	50	100		
60-70	SA-1000, SB-1500, SC-2640		730	235	840	60	120		
Urban Low Speed - 100 FT									

APPROVED/ACCEPTED BY:
ENGINEER, OWNER, or PRIME CONTRACTOR

Check for Notice to Proceed.

Signature: _____

Company: _____

Date: 10/31/2023 Project: BLN01a-F02_E 19th St TCP2 :
: **Traffic Control Suggestion For:** ATLANTIC ENGINEERING (AEG) :
By: Road Runner Safety Services, Inc. : Nathan

Comments:
Drawing not to scale. Traffic control plan must be approved by an engineer. This is a suggestion only. Road Runners Safety Services, Inc. has no liability for this suggested traffic control plan. Actual placement and spacing of all traffic control devices will depend on field conditions and must conform to MUTCD standards.



Legend

- ADA Barricade
- Arrow Board
- Flagger (Person)
- Sign
- Trimline
- Vault
- Work Area

Road Construction Ahead signs to be placed on all side streets within work area. Sidewalk Closed Ahead Cross Here signs to be placed at nearest crossing.

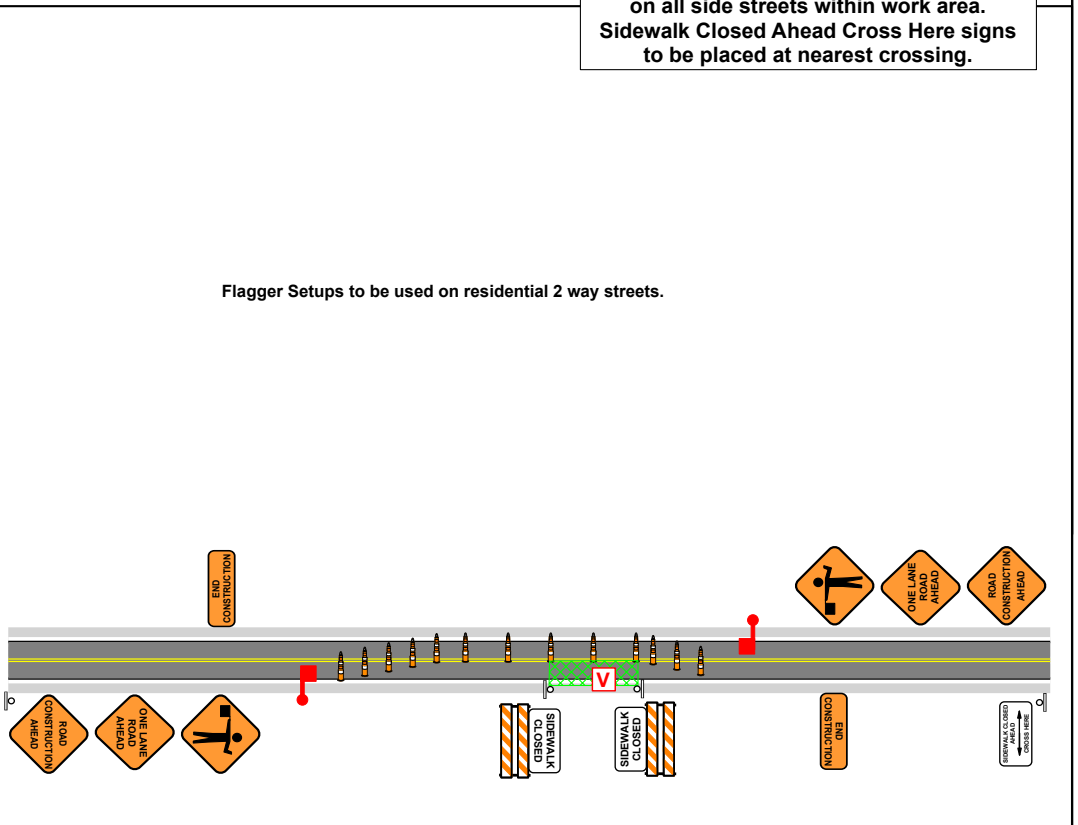
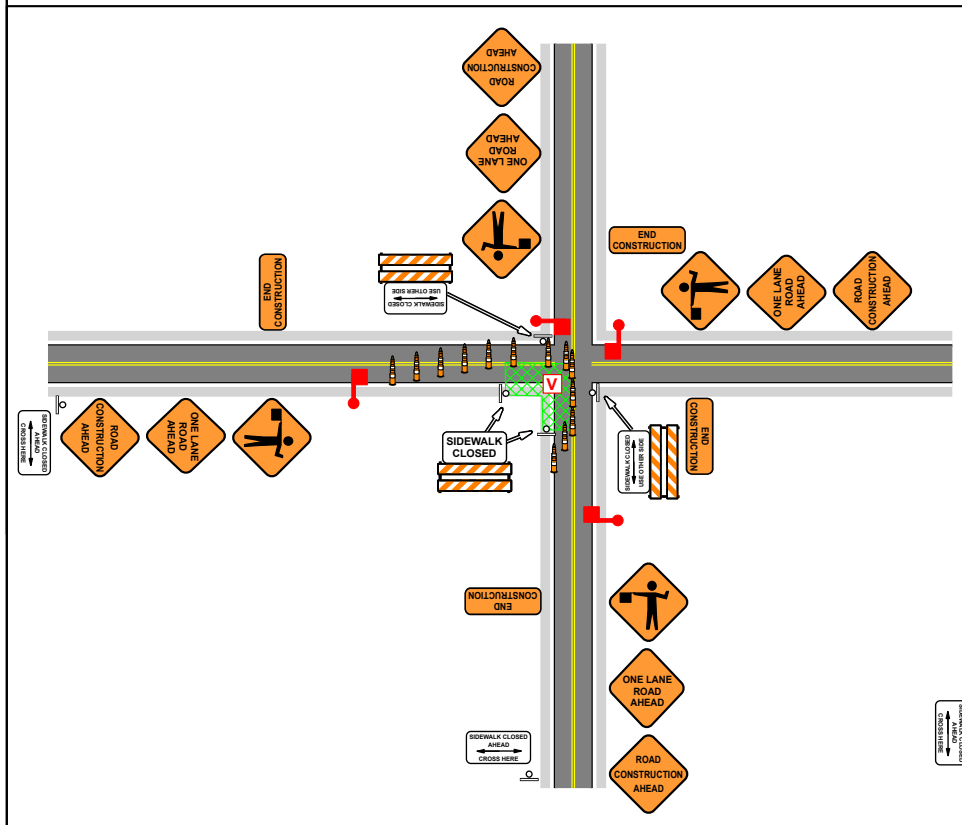

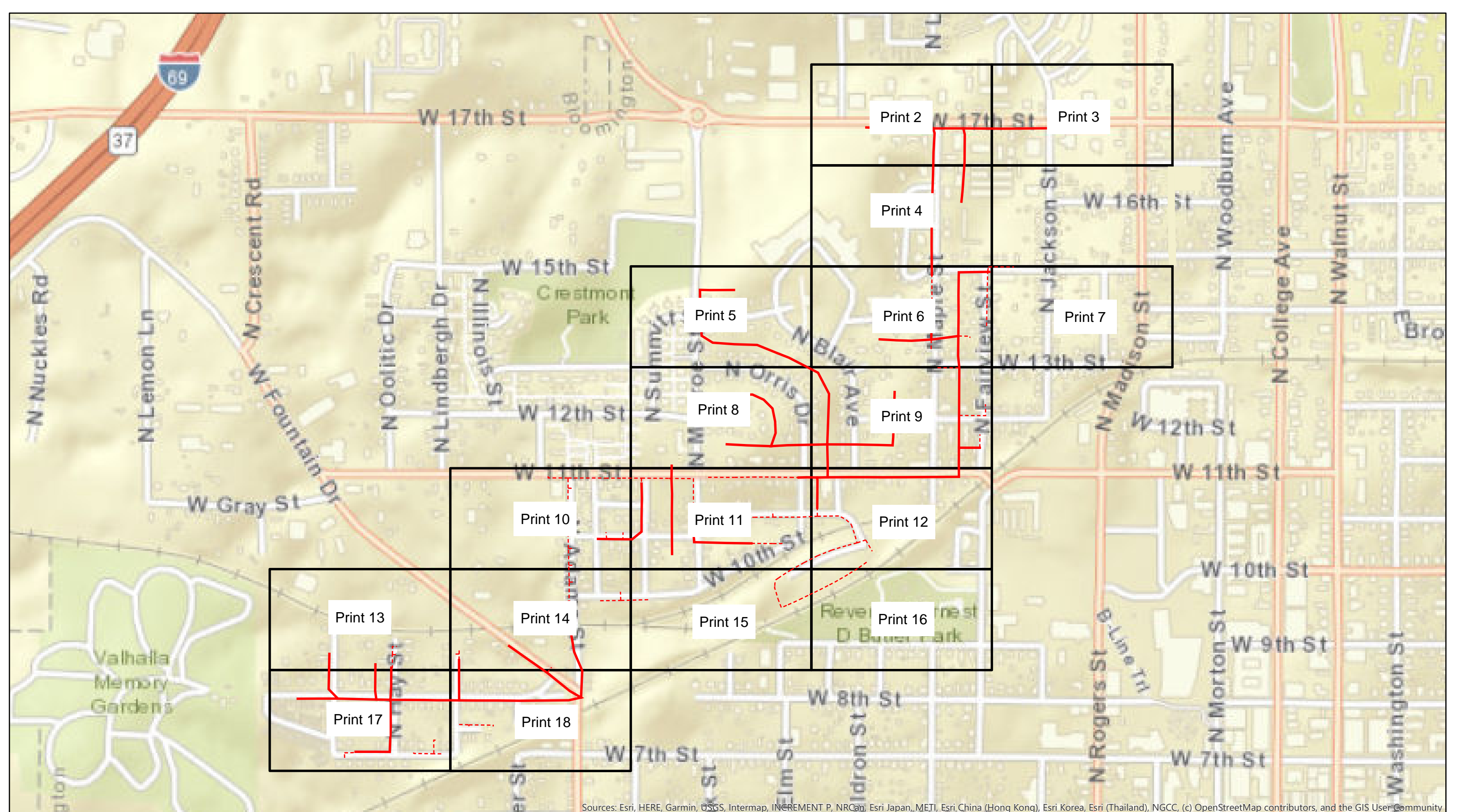

Sources: Esri, HERE, Garmin, USGS, Intermap, INCREMENT P, NRCan, Esri Japan, METI, Esri China (Hong Kong), Esri Korea, Esri (Thailand), NGCC, (c) OpenStreetMap contributors, and the GIS User Community



Legend BLN01b-F12_N Hay St

- Overhead Strand
- - - Conduit
- Grids

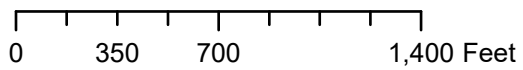







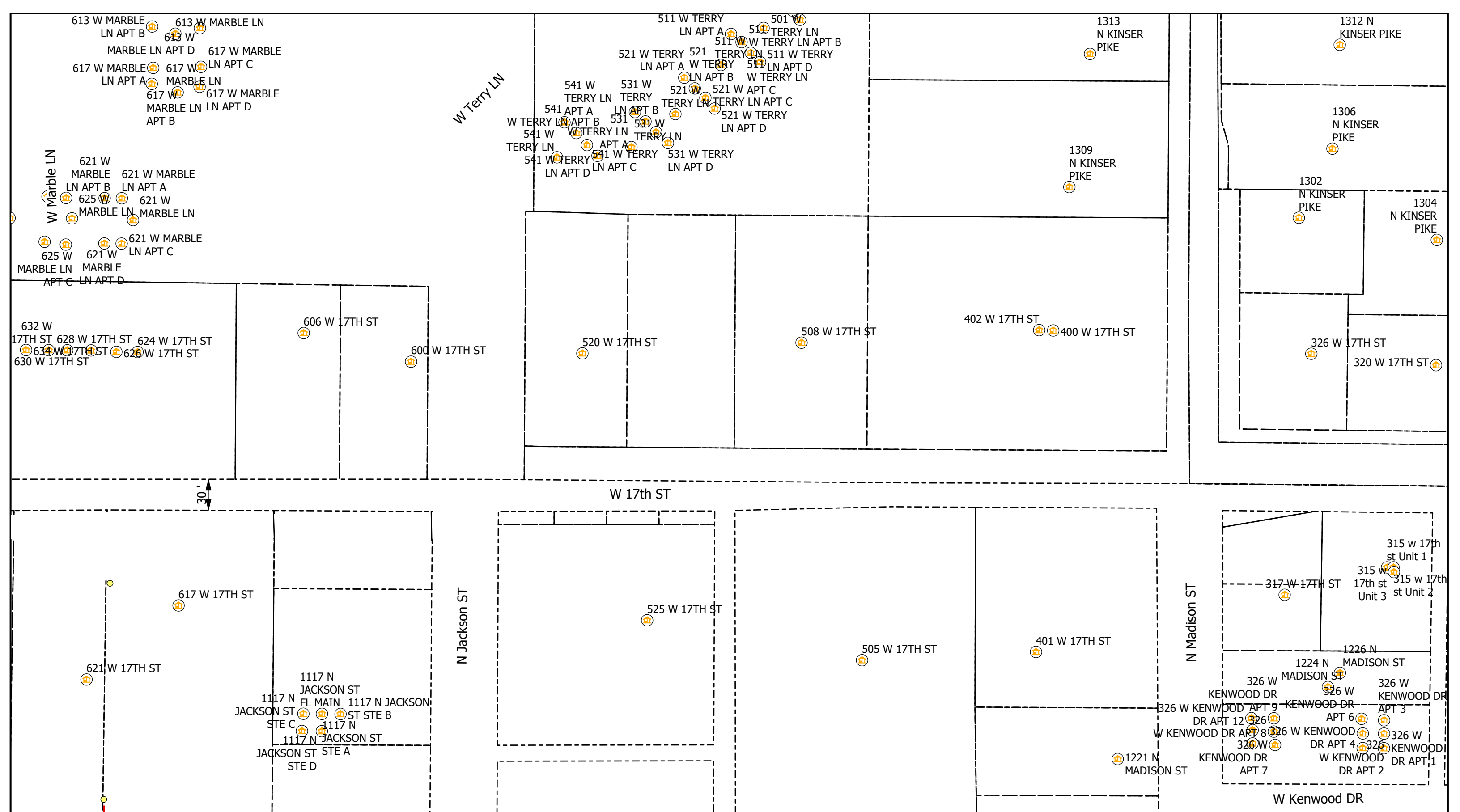

City of Bloomington, IN Permit:
Design View

INI	BY	DATE	DESCRIPTION

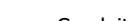
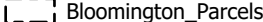



Legend

-  Poles
-  Vaults
-  Overhead Strand
-  Conduit
-  Bloomington_Parcels
-  Risers
-  Address
-  Anchor
-  Sidewalk
-  Grids

All Flowerpots 12" DIA



City of Bloomington, IN Permit:
Design View

INI	BY	DATE	DESCRIPTION



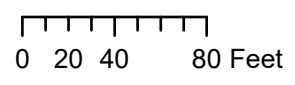
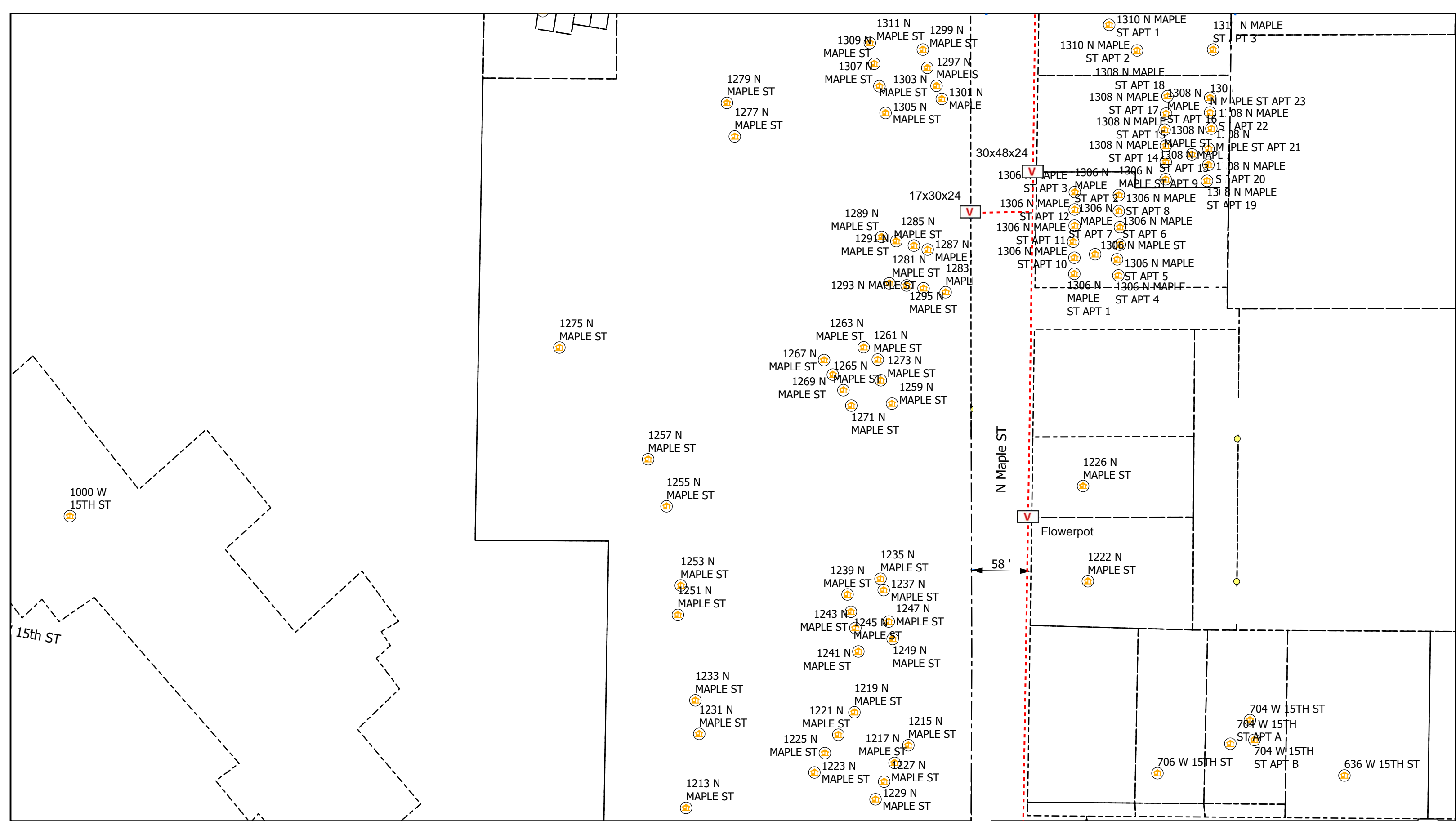

Legend

- Poles
- V Vaults
- Overhead Strand
- Conduit
- Bloomington_Parcels
- R Risers
- A Address
- Y Anchor
- ← Sidewalk
- Grids

All Flowerpots 12" DIA



City of Bloomington, IN Permit:
Design View

INI	BY	DATE	DESCRIPTION



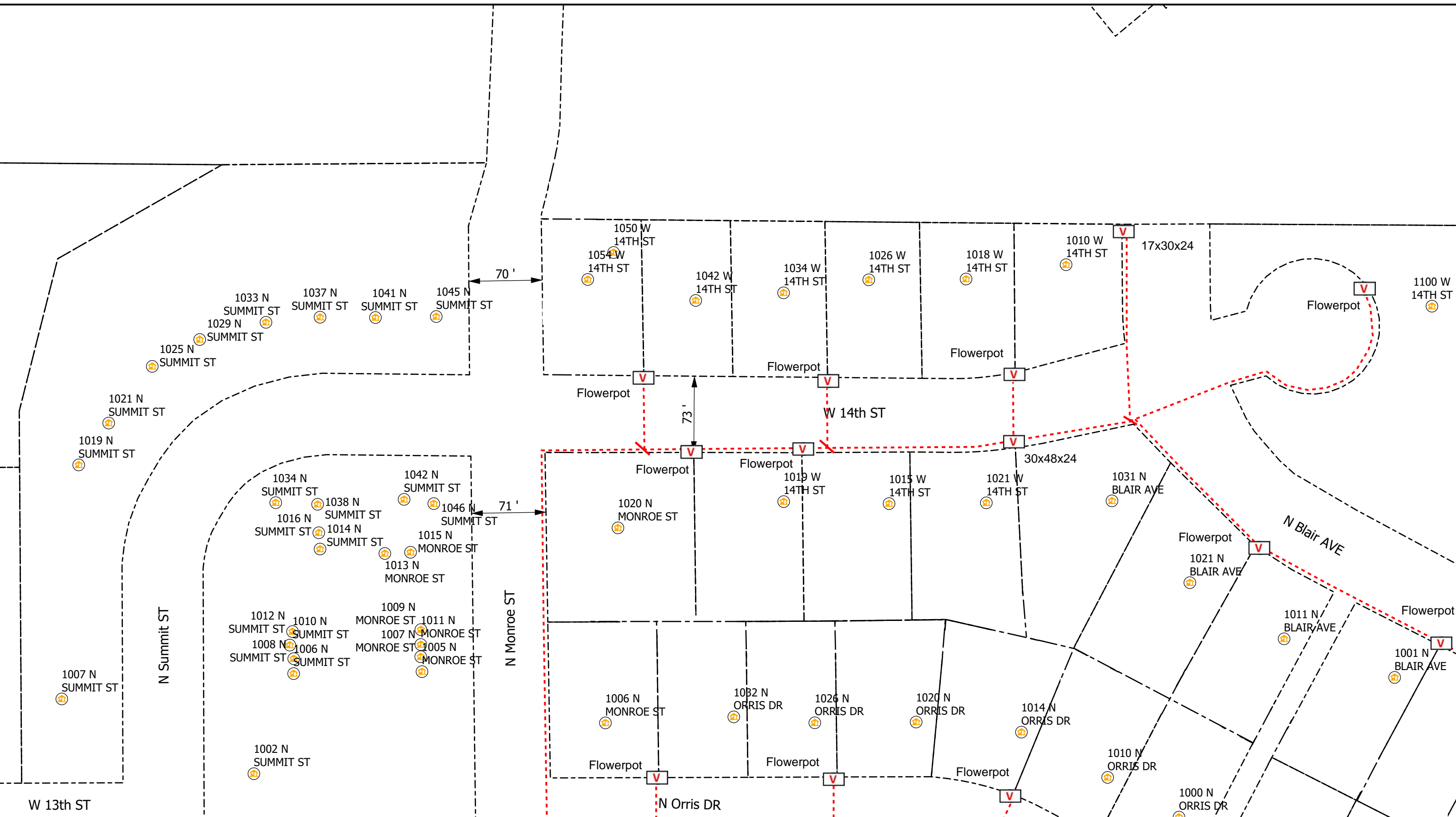

0 20 40 80 Feet

Legend

- Poles
- V Vaults
- Overhead Strand
- Conduit
- Bloomington_Parcels
- R Risers
- A Address
- Y Anchor
- ← Sidewalk
- Grids

All Flowerpots 12" DIA

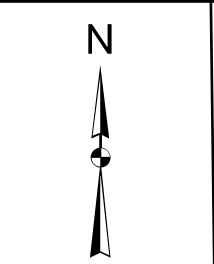

City of Bloomington, IN Permit:
Design View

INI	BY	DATE	DESCRIPTION

Print 5 of 18

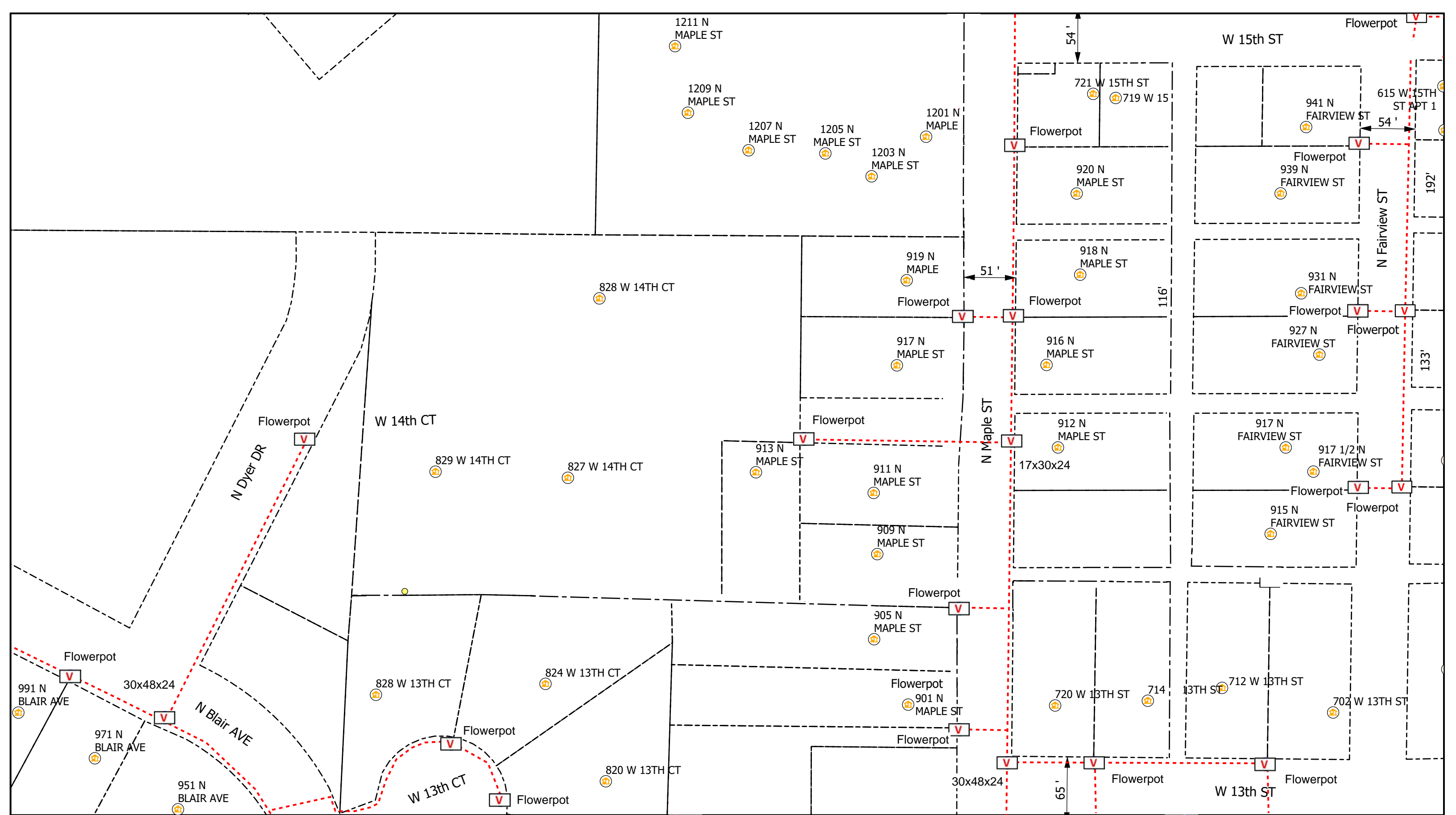

0 20 40 80 Feet

Legend

- Poles
- V Vaults
- Overhead Strand
- Conduit
- Bloomington_Parcels
- R Risers
- A Address
- Y Anchor
- ← Sidewalk
- Grids

All Flowerpots 12" DIA



City of Bloomington, IN Permit:
Design View

INI	BY	DATE	DESCRIPTION



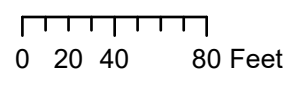
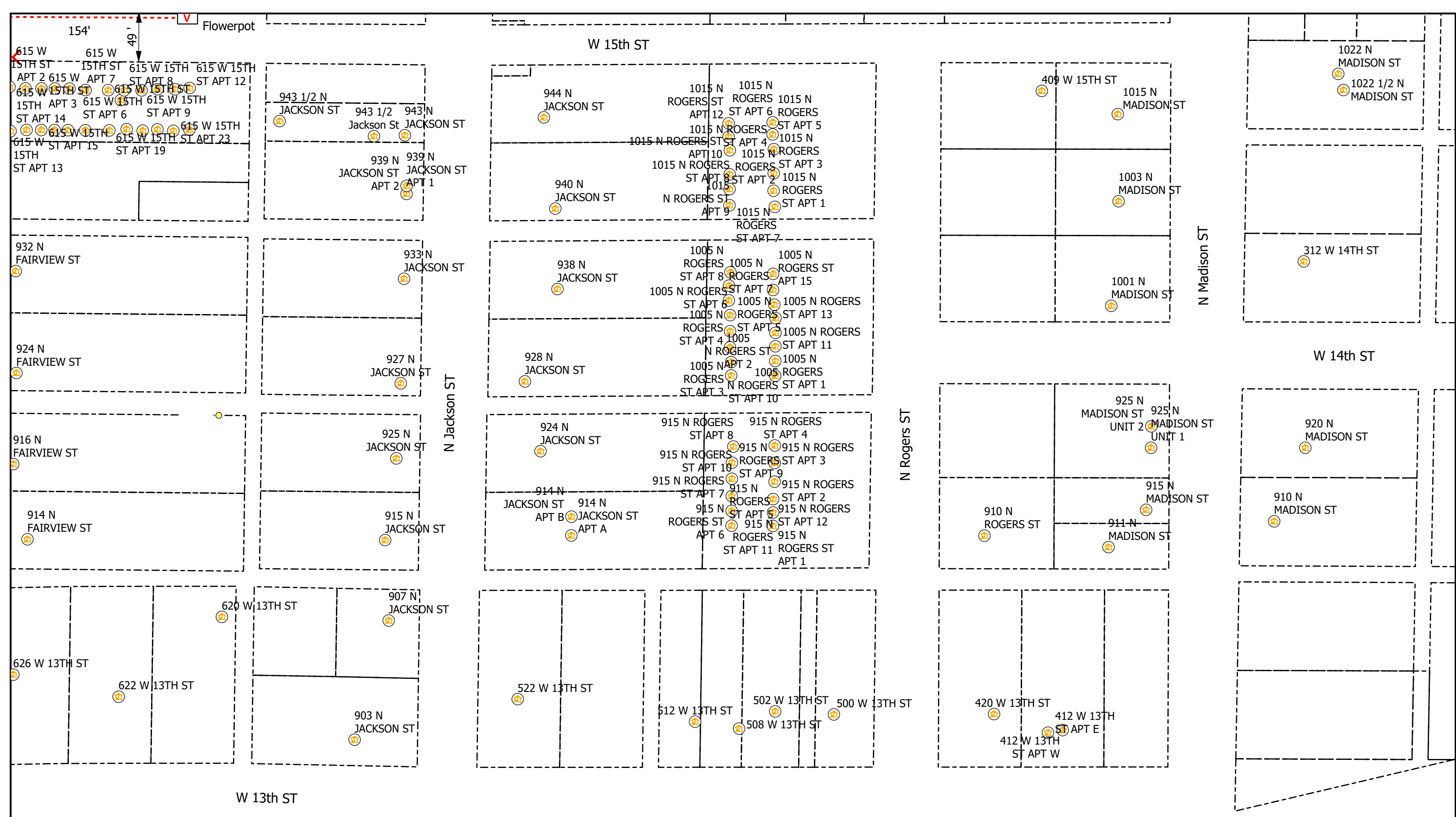

Legend

- Poles
- V Vaults
- Overhead Strand
- Conduit
- Bloomington_Parcels
- R Risers
- A Address
- Y Anchor
- ← Sidewalk
- Grids

All Flowerpots 12" DIA



City of Bloomington, IN Permit:
Design View

INI	BY	DATE	DESCRIPTION



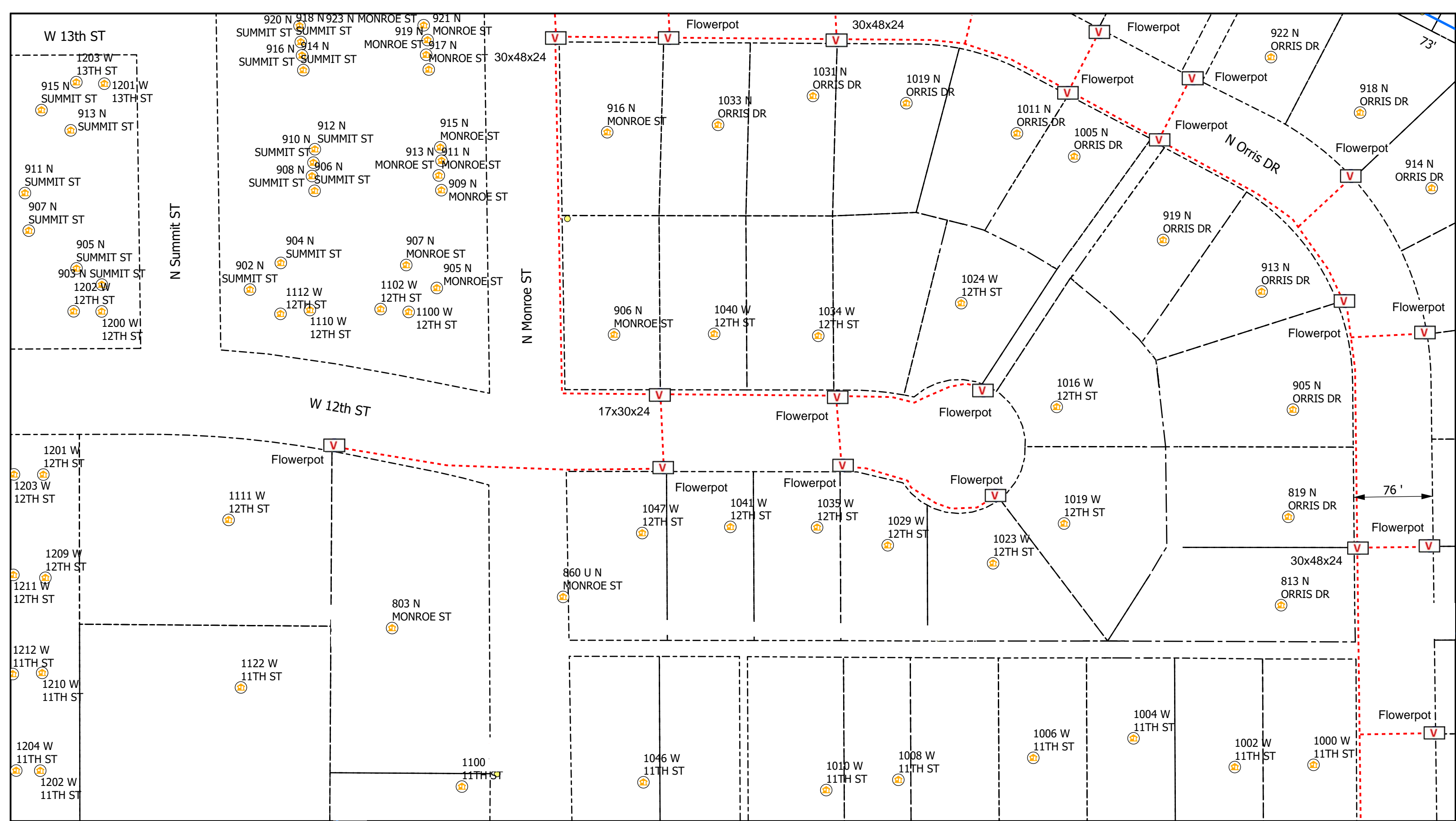

0 20 40 80 Feet

Legend

- Poles
- Vaults
- Overhead Strand
- Conduit
- Bloomington_Parcels
- Risers
- Address
- Anchor
- Sidewalk
- Grids

All Flowerpots 12" DIA



City of Bloomington, IN Permit:
Design View

INI	BY	DATE	DESCRIPTION



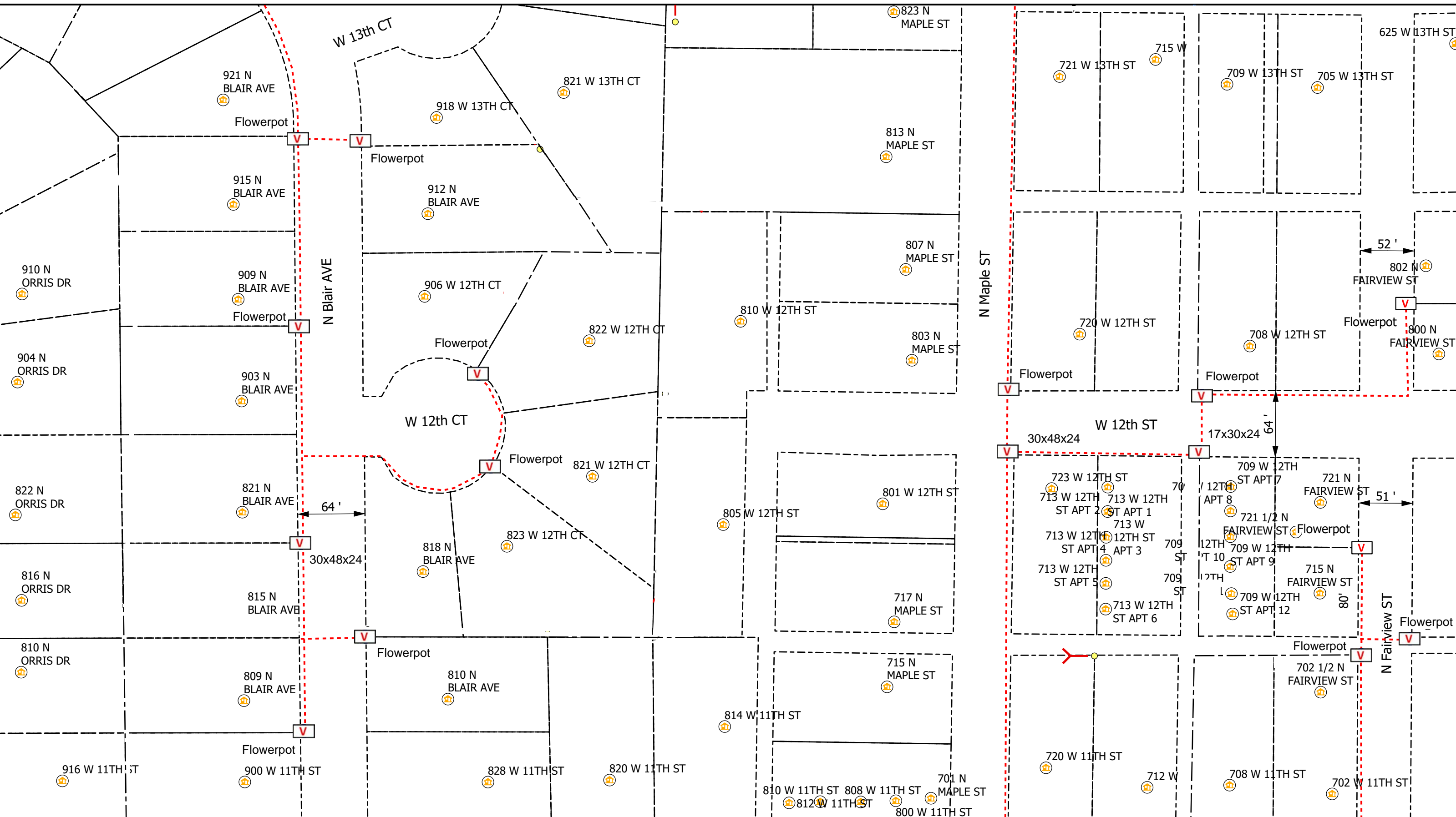

0 20 40 80 Feet

Legend

- Poles
- Vaults
- Overhead Strand
- Conduit
- Bloomington_Parcels
- Risers
- Address
- Anchor
- Sidewalk
- Grids

All Flowerpots 12" DIA



City of Bloomington, IN Permit:
Design View

INI	BY	DATE	DESCRIPTION



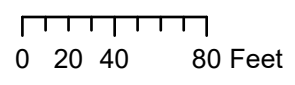
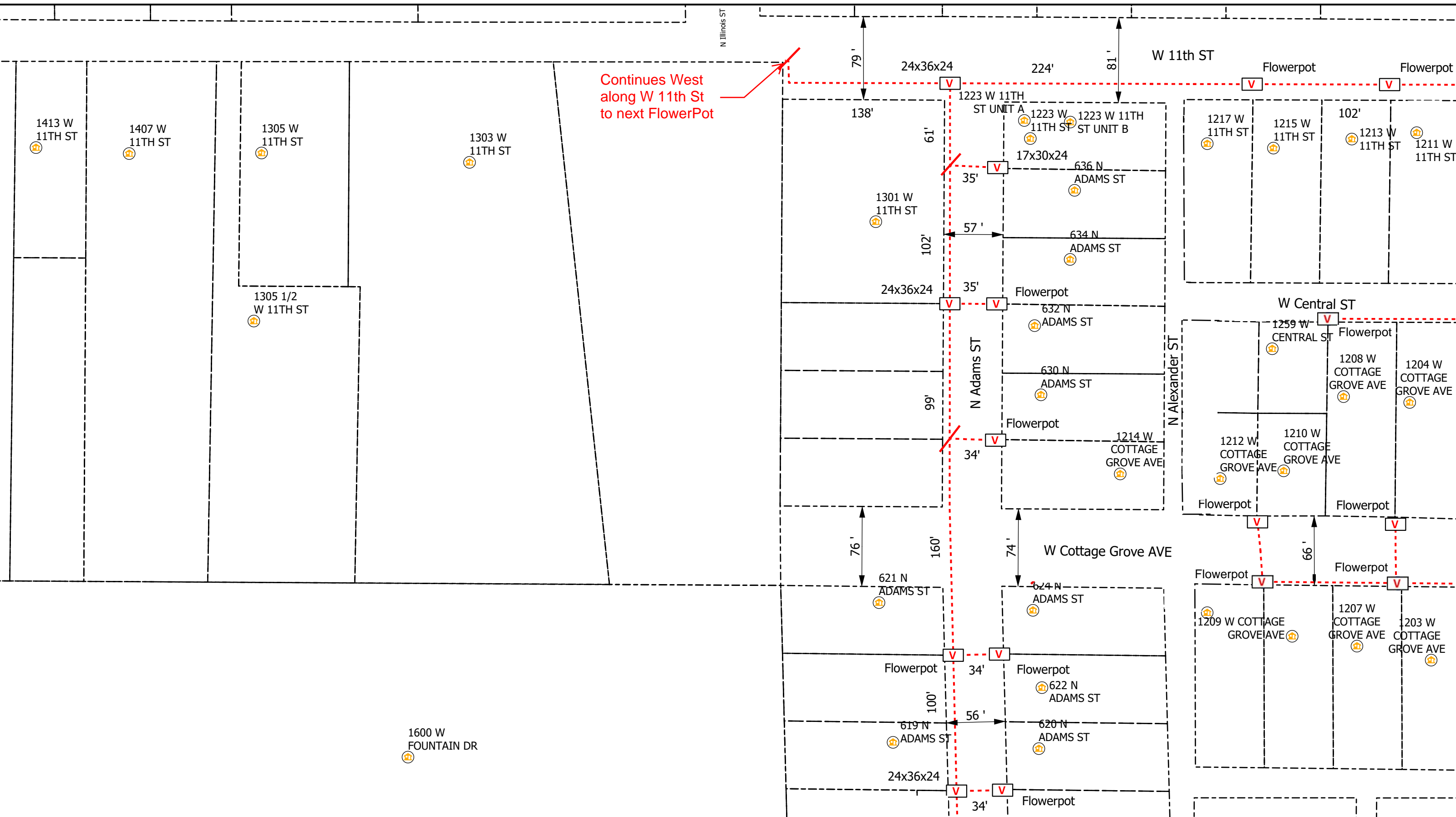

Legend

- Poles
- V Vaults
- Overhead Strand
- Conduit
- Bloomington_Parcels
- R Risers
- A Address
- Y Anchor
- ← Sidewalk
- Grids

All Flowerpots 12" DIA



City of Bloomington, IN Permit:
Design View

INI	BY	DATE	DESCRIPTION



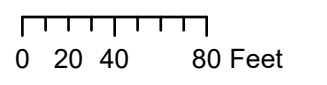
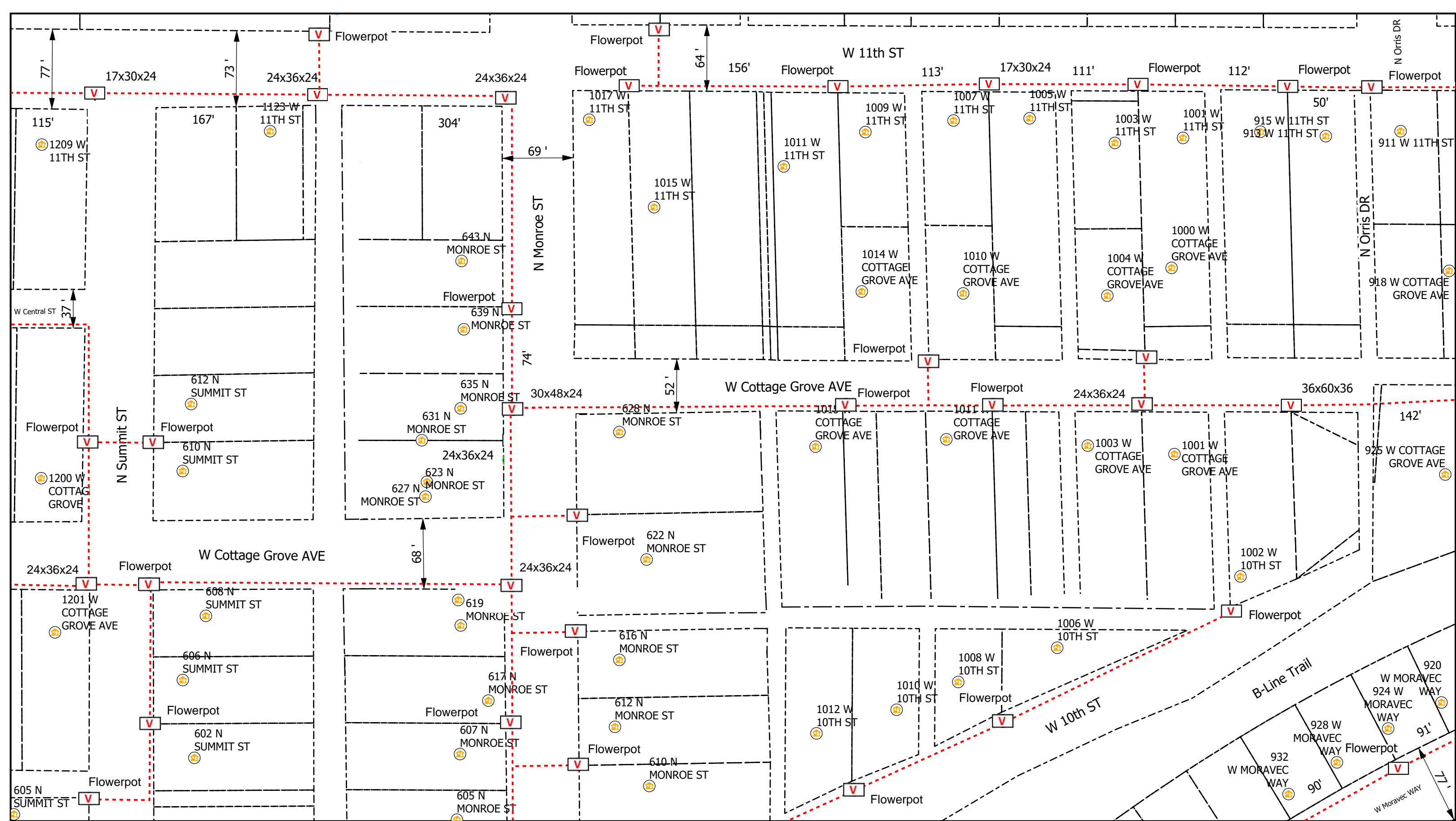

Legend

- Poles
- V Vaults
- Overhead Strand
- Conduit
- Bloomington_Parcels
- R Risers
- ⊙ Address
- Y Anchor
- ← Sidewalk
- Grids

All Flowerpots 12" DIA



City of Bloomington, IN Permit:
Design View

INI	BY	DATE	DESCRIPTION



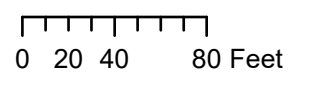
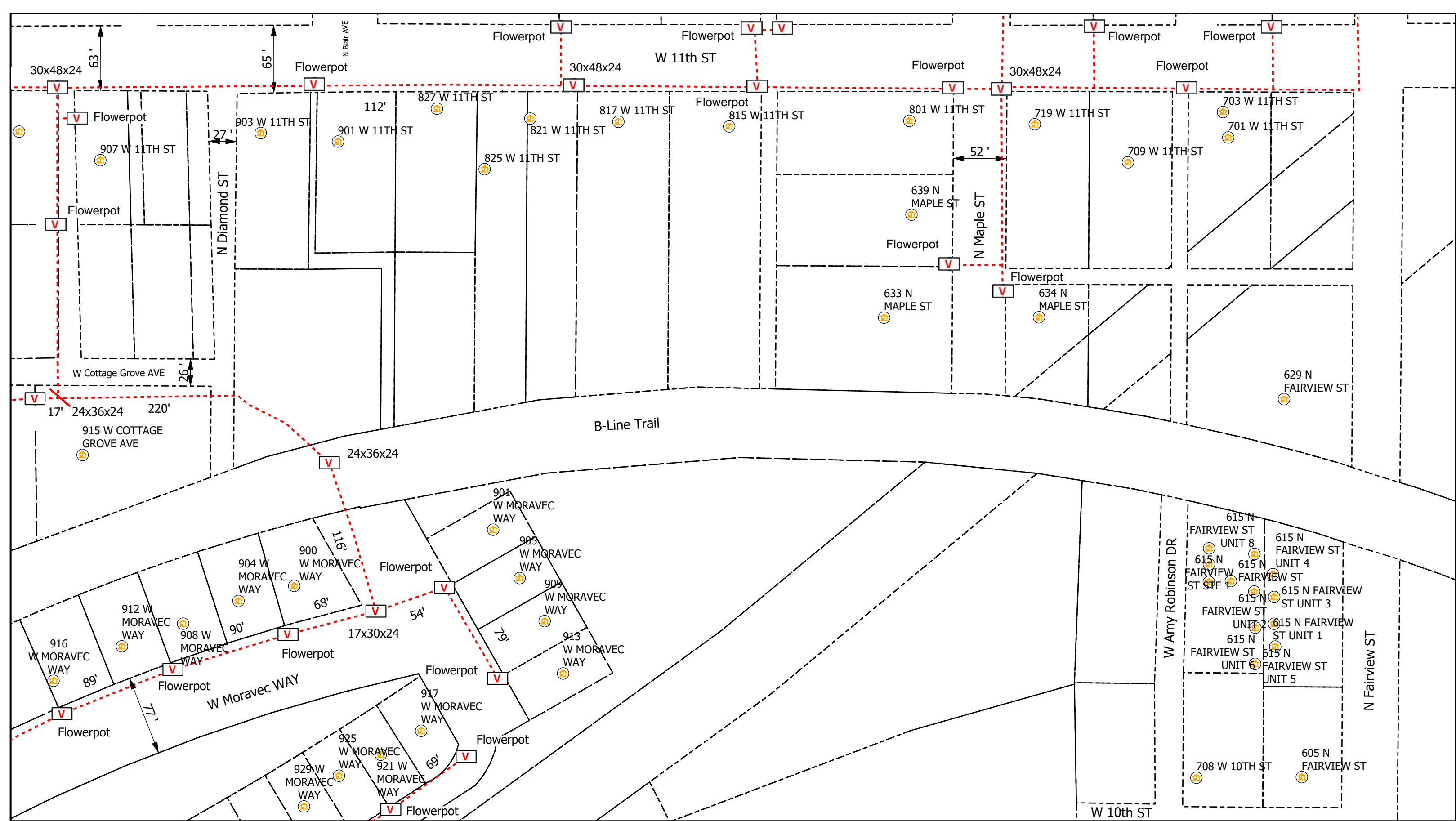

Legend

- Poles
- Vaults
- Overhead Strand
- Conduit
- Bloomington_Parcels
- Risers
- Address
- Anchor
- Sidewalk
- Grids

All Flowerpots 12" DIA



City of Bloomington, IN Permit:
Design View

INI	BY	DATE	DESCRIPTION



620 N NORTH ST

1803 W FOUNTAIN DR

W Fountain DR

415 N SPRING ST

Flowerpot

60'

413 N SPRING ST

Flowerpot

411 N SPRING ST

N Spring ST

410 N SPRING ST

Flowerpot

406 N SPRING ST

Flowerpot

1634 W 8TH ST

1630 W 8TH ST

Anchor

425 N HAY ST

Flowerpot

417 N HAY ST

N Hay ST

45'

Flowerpot

428 N HAY ST

424 N HAY ST

Flowerpot

420 N HAY ST

429 N HOPEWELL ST

421 N HOPEWELL ST

405 N HOPEWELL ST

1706 W 8TH ST



Legend

- Poles
- Vaults
- Overhead Strand
- Conduit
- Bloomington_Parcels
- Risers
- Address
- Anchor
- Sidewalk
- Grids

All Flowerpots 12" DIA



City of Bloomington, IN Permit:
Design View

INI	BY	DATE	DESCRIPTION



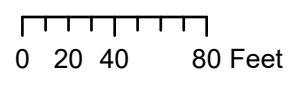
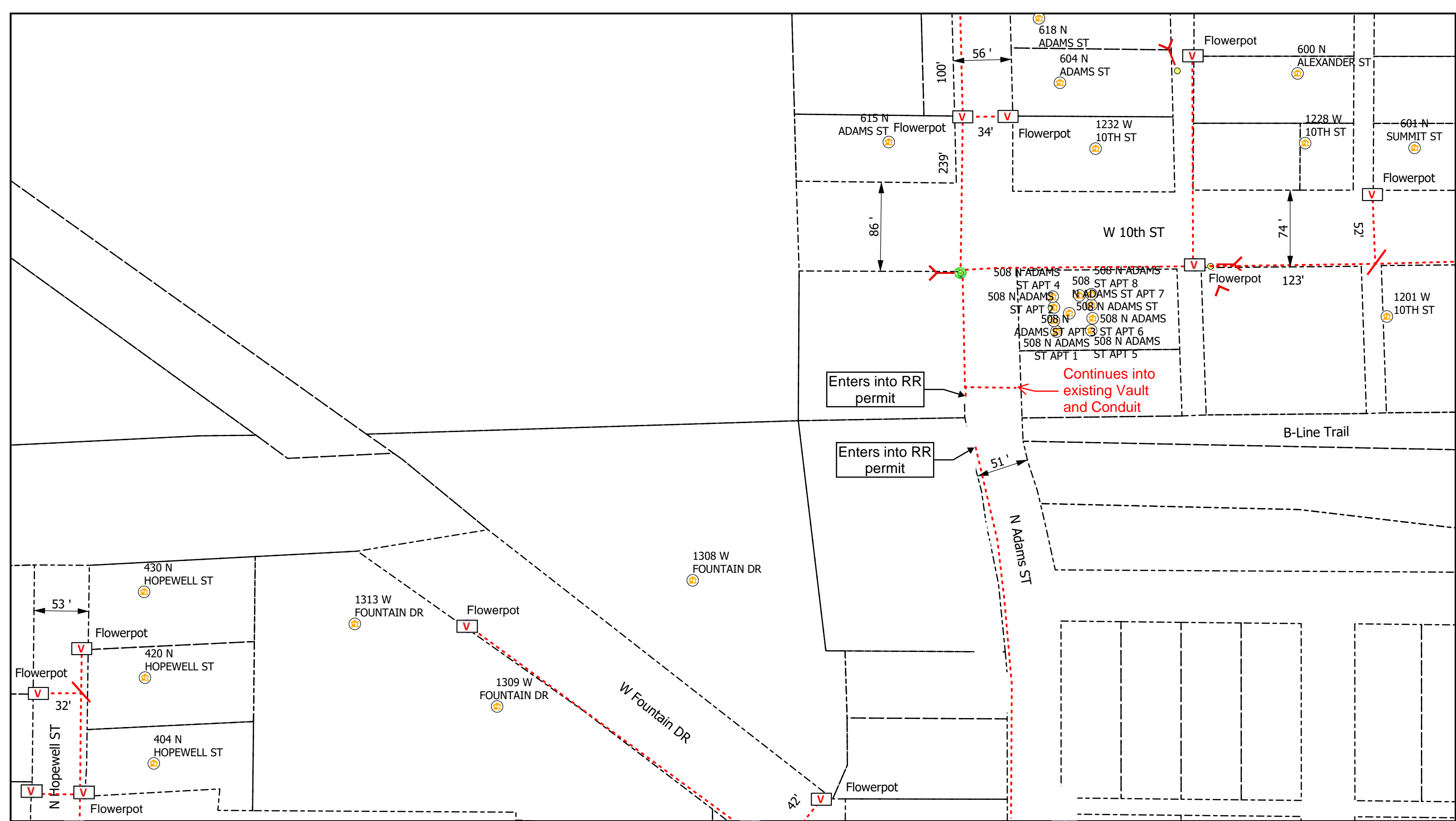

Legend

- Poles
- Vaults
- Overhead Strand
- Conduit
- Bloomington_Parcels
- Risers
- Address
- Anchor
- Sidewalk
- Grids

All Flowerpots 12" DIA



City of Bloomington, IN Permit:
Design View

INI	BY	DATE	DESCRIPTION



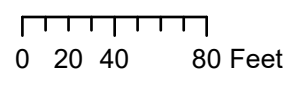
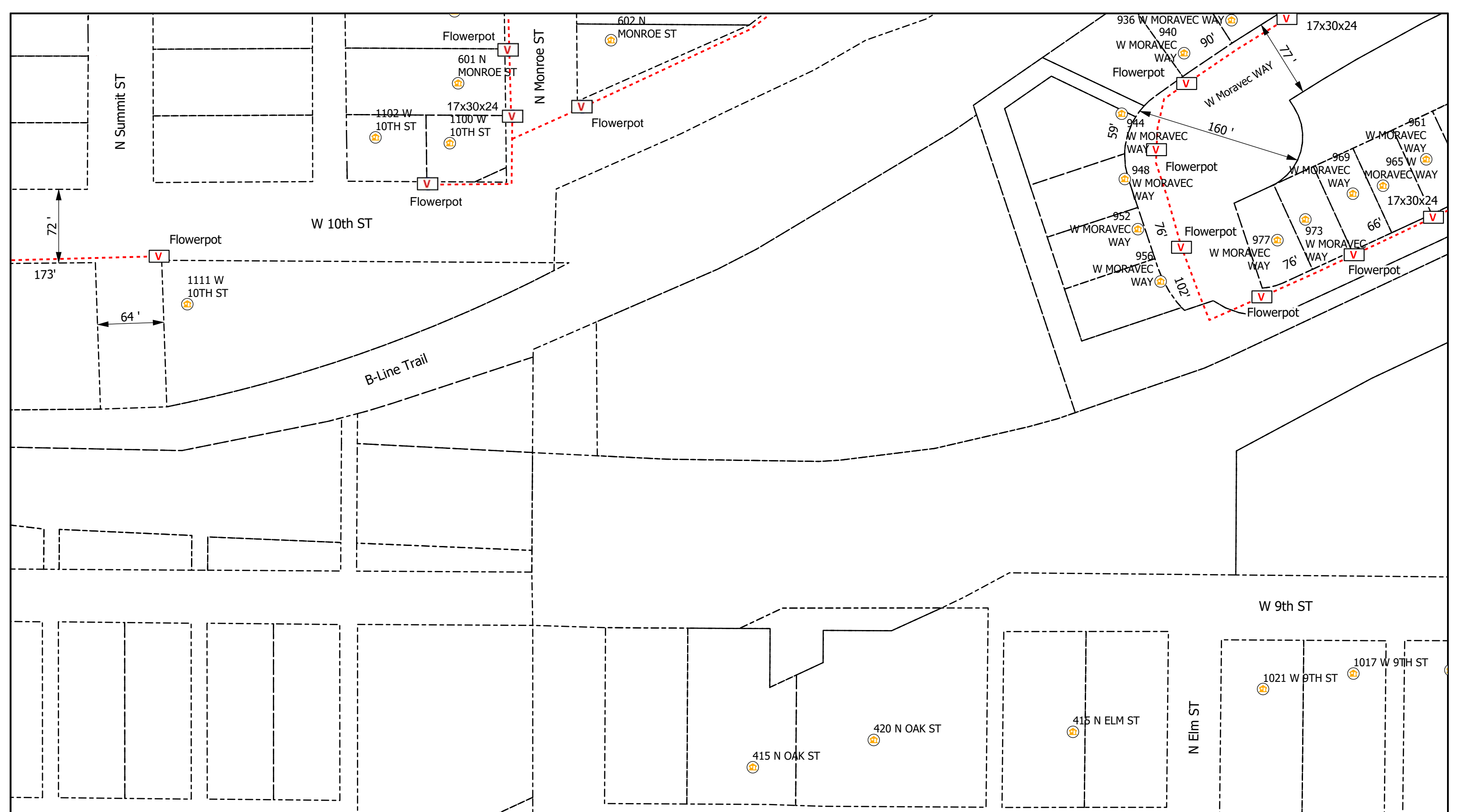

Legend

- Poles
- Vaults
- Overhead Strand
- Conduit
- Bloomington_Parcels
- Risers
- Address
- Anchor
- Sidewalk
- Grids

All Flowerpots 12" DIA



City of Bloomington, IN Permit:
Design View

INI	BY	DATE	DESCRIPTION



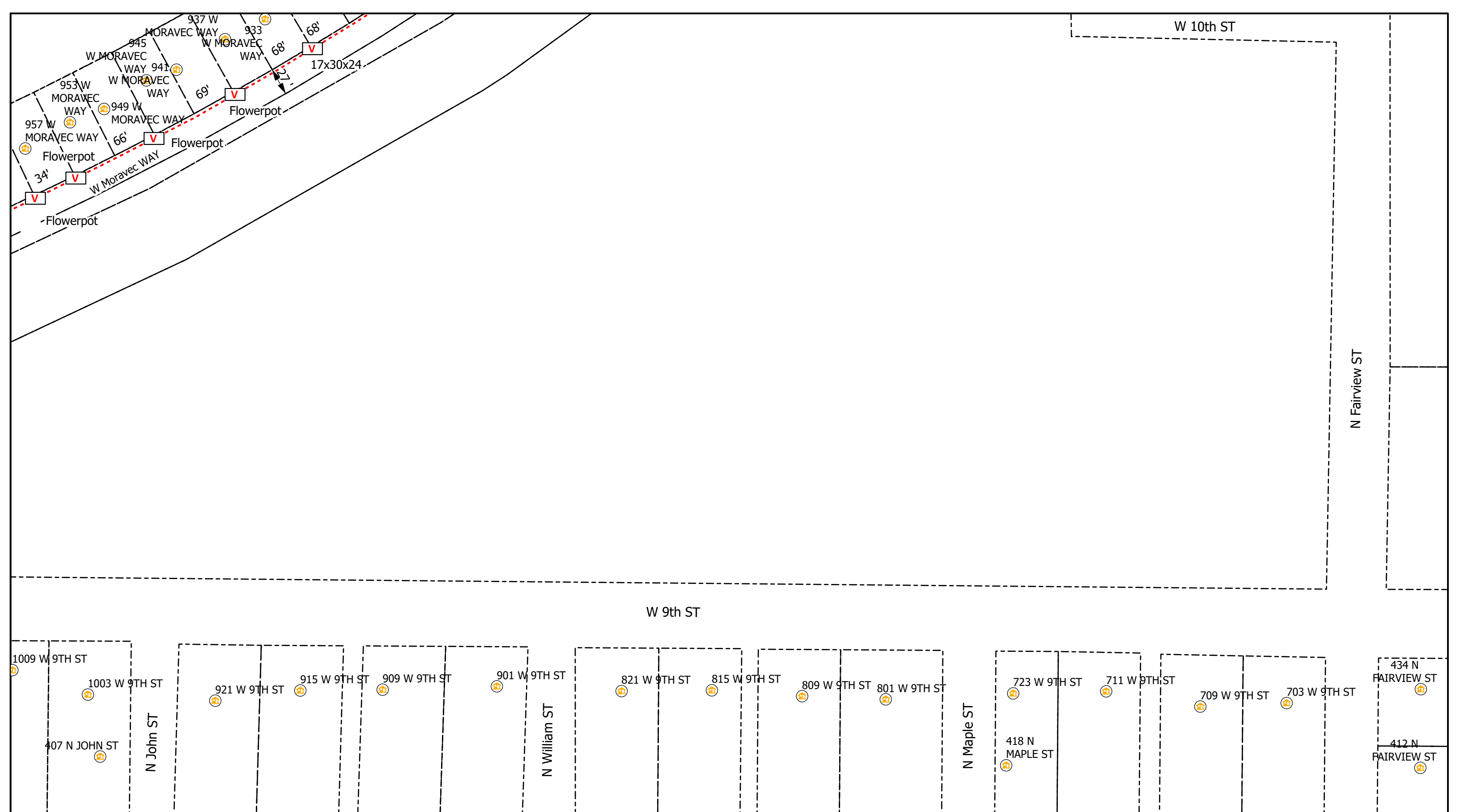

0 20 40 80 Feet

Legend

- Poles
- Vaults
- Overhead Strand
- Conduit
- Bloomington_Parcels
- Risers
- Address
- Anchor
- Sidewalk
- Grids

All Flowerpots 12" DIA



City of Bloomington, IN Permit:
Design View

INI	BY	DATE	DESCRIPTION



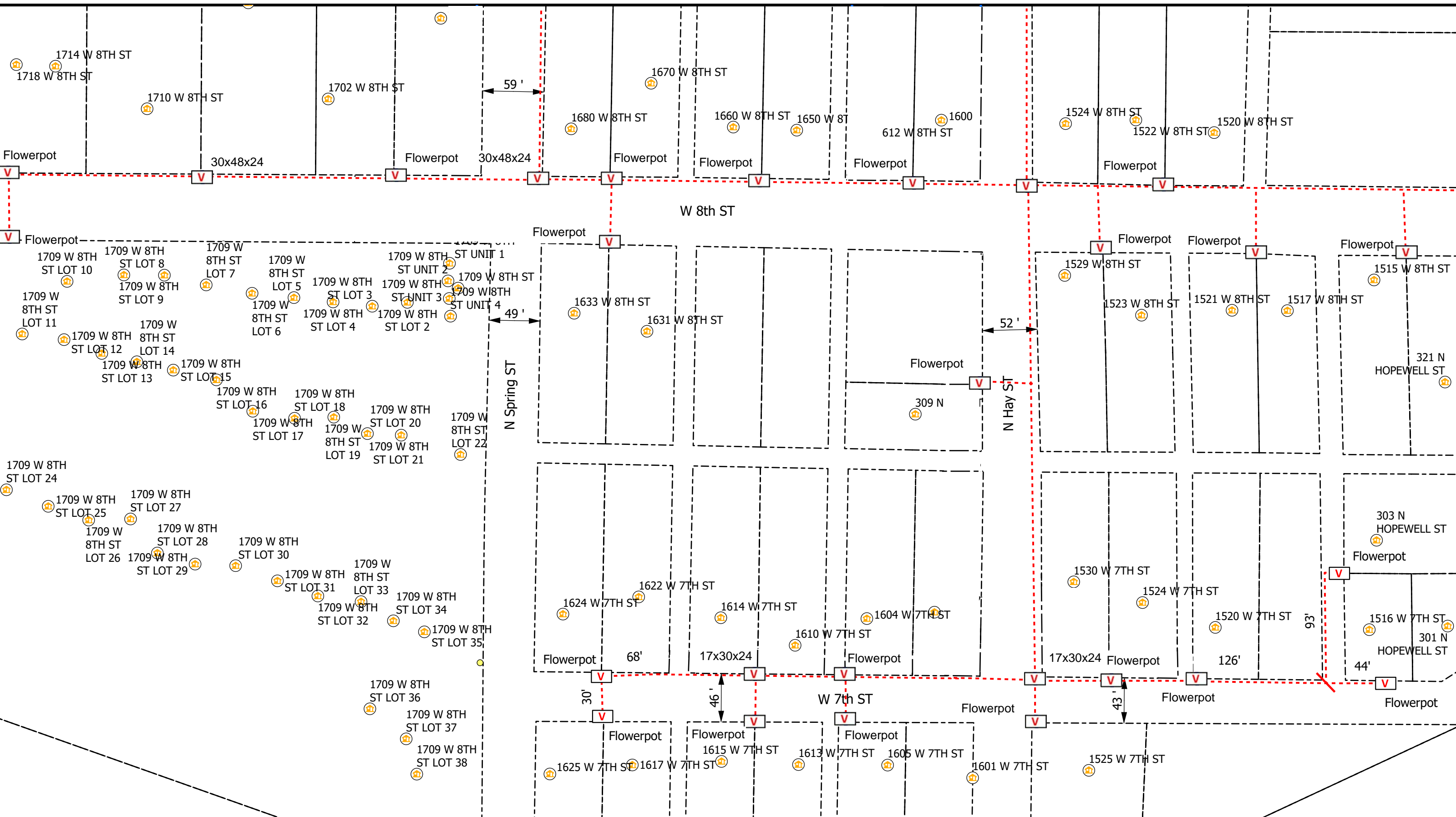

Legend

- Poles
- V Vaults
- Overhead Strand
- Conduit
- Bloomington_Parcels
- R Risers
- A Address
- Y Anchor
- ← Sidewalk
- Grids

All Flowerpots 12" DIA

City of Bloomington, IN Permit:
Design View

INI	BY	DATE	DESCRIPTION

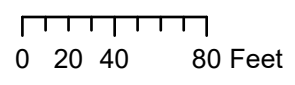
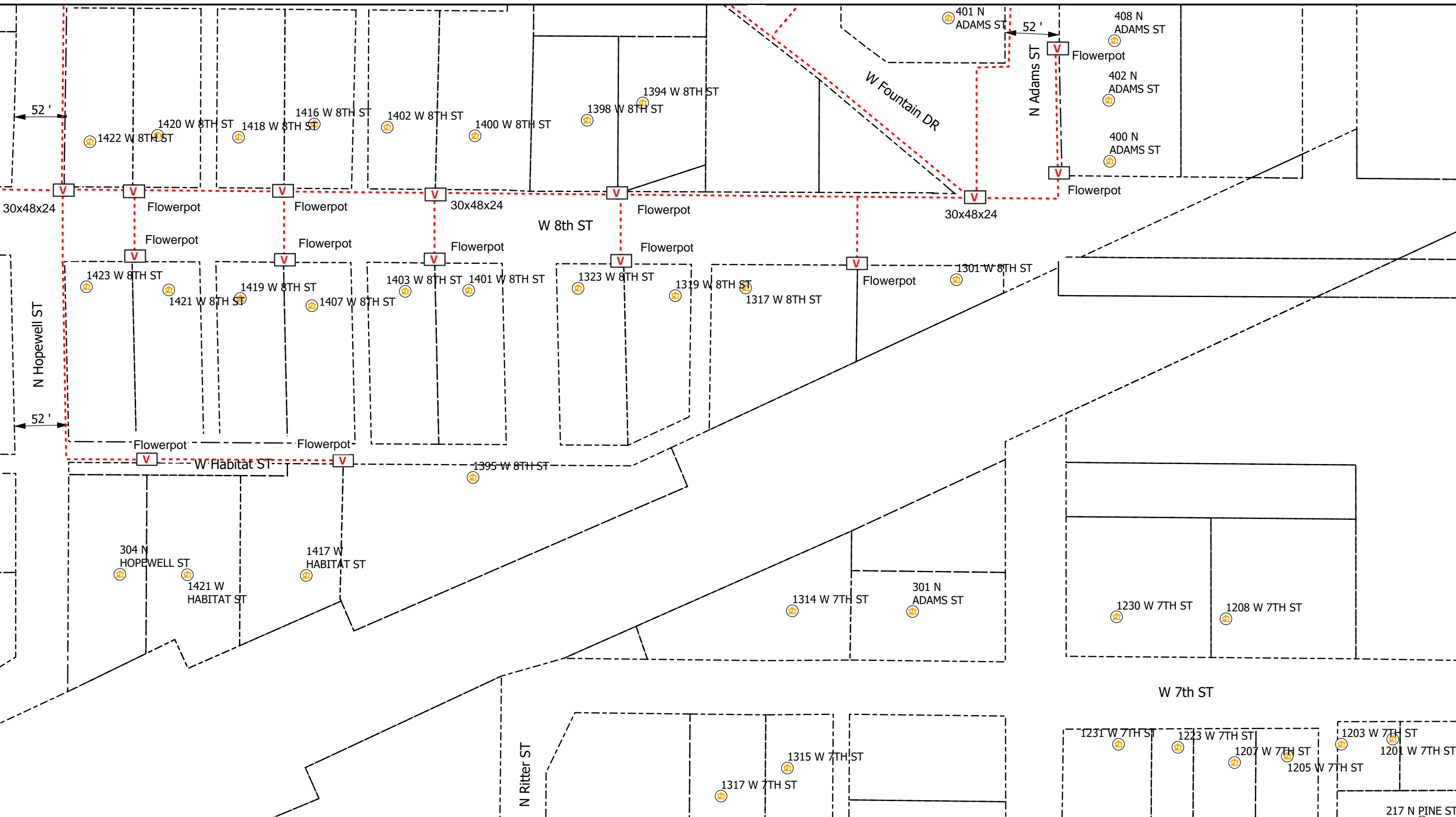

Legend

- Poles
- Vaults
- Overhead Strand
- Conduit
- Bloomington_Parcels
- Risers
- Address
- Anchor
- Sidewalk
- Grids

All Flowerpots 12" DIA



City of Bloomington, IN Permit:
Design View

INI	BY	DATE	DESCRIPTION



Carlton® PV-Mold® Nonmetallic Pole Riser System

Carlton PV-Mold is a nonmetallic pole riser system designed to protect communications power cable installed on poles.

Features:

- Meets or exceeds requirements outlined in the National Electric Safety Code (NESC).
- Designed in accordance with NEMA TC-19 specifications.
- Ultraviolet, cold temperature and corrosive atmosphere resistant.
- Schedule 40 wall meets Schedule 80 PVC conduit impact requirements per NEMA TC-19.
- No grounding required.
- Belled end fits over each added section or conduit.
- Flame retardant.
- Requires no maintenance.
- PV-Mold acts as an insulator against electrical shock.
- Interchangeable parts and accessories to match the needs of specific requirements.



Steel U-Guard requires grounding strapping and does not have belled ends.



PV-Mold has belled ends, flanged design and does not require grounding.

Flanged Overall Length 10 Feet, Including Bell

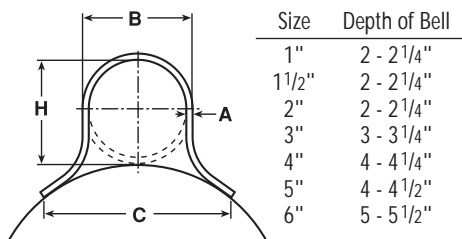

Slots are 1/2" from side to side, and allow for expansion and contraction.

Slot Dimensions: for sizes 2" through 6" are 5/16" wide, 3/4" long.

Slot Dimensions: for 1" and 1 1/2" are 3/16" wide, 3/4" long.

Slot Spacing: 18" from center, beginning 6" from end.

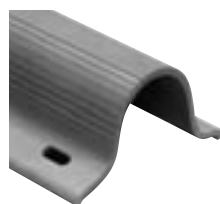

Standard Duty

Part No.	Size	Std. Ctn. Qty.	Std. Ctn. Wt. (lbs.)	Dimensions				Actual Impact @ 0°C 20 Pound Top
				A	B	C	H	
59208N	1"	294	1059	0.100"	1 5/8"	2 3/8"	1 5/8"	40 Ft.-Lbs.
59211N	2"	136	726	0.100"	2 3/8"	4 1/2"	2 3/8"	100 Ft.-Lbs.
59211X (5' length)	2"	136	363	0.100"	2 3/8"	4 1/2"	2 3/8"	100 Ft.-Lbs.
59213N	3"	66	761	0.150"	3 1/2"	6"	3 1/2"	110 Ft.-Lbs.
59213X (5' length)	3"	66	381	0.150"	3 1/2"	6"	3 1/2"	100 Ft.-Lbs.
59215N	4"	65	910	0.150"	4 1/2"	6 1/2"	4 1/2"	110 Ft.-Lbs.
59216N	5"	30	515	0.150"	5 1/2"	7 1/2"	5 1/2"	110 Ft.-Lbs.

Heavy Duty Schedule 40

59010N	1 1/2"	200	1142	0.145"	1 29/32"	3 1/2"	1 29/32"	100 Ft.-Lbs.
59011N	2"	136	1214	0.154"	2 3/8"	4 1/2"	2 3/8"	150 Ft.-Lbs.
59013N	3"	66	937	0.216"	3 1/2"	6"	3 9/32"	150 Ft.-Lbs.
59015N	4"	65	1621	0.237"	4 1/2"	6 1/2"	4 1/2"	260 Ft.-Lbs.
59015X (5' length)	4"	65	707	0.237"	4 1/2"	6 1/2"	4 1/2"	260 Ft.-Lbs.
59016N	5"	30	870	0.258"	5 1/2"	7 1/2"	5 1/2"	260 Ft.-Lbs.
59017N	6"	30	1160	0.280"	6 5/8"	8 3/4"	6 5/8"	260 Ft.-Lbs.

Extra Heavy Duty Schedule 80

59411N	2"	136	1549	0.218"	2 3/8"	4 1/2"	2 3/8"	300 Ft.-Lbs.
59413N	3"	66	1495	0.030"	3 1/2"	6"	3 1/2"	525 Ft.-Lbs.

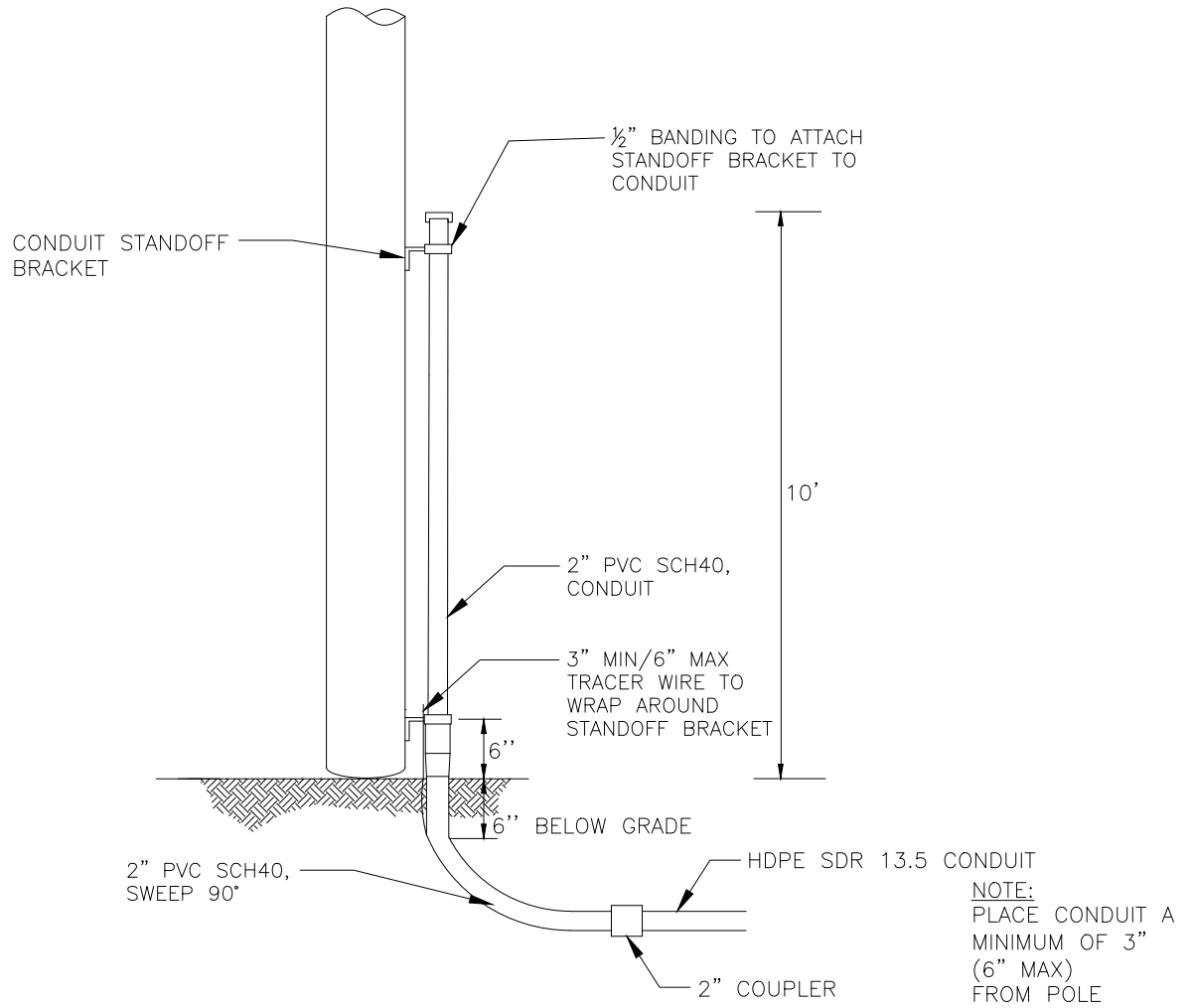

DESCRIPTION

QTY

MANUFACTURER
(PREFERRED)

PART #

SCREW, LAG, 1/2" x 4-1/2"	10		
HDPE SDR 13.5 CONDUIT, VARIOUS SIZES	N/A		
2" PVC SCH40, RISER PIPE	1		
#12 TRACER WIRE	N/A		
2" PVC SCH40, SWEEP, 90 DEG	1		
CONDUIT STANDOFF BRACKET	VARIES		
CONDUIT STRAP KIT	VARIES		
2" COUPLER	1		

NOTE:
PLACE CONDUIT A
MINIMUM OF 3"
(6" MAX)
FROM POLE



TYPICAL RISER
CONDUIT
WOOD POLE

(R2-W)

CONCEPTUAL SIDE VIEW

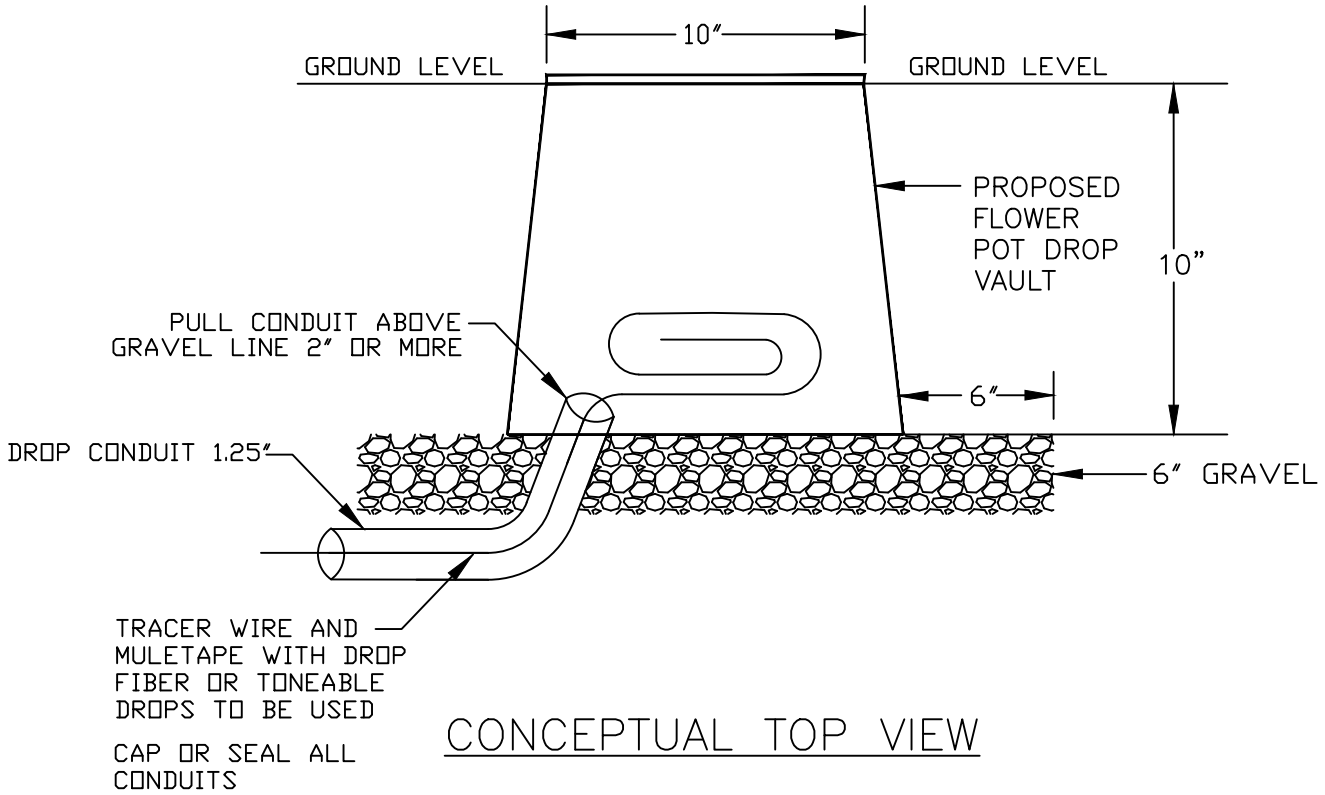

CONCEPTUAL TOP VIEW

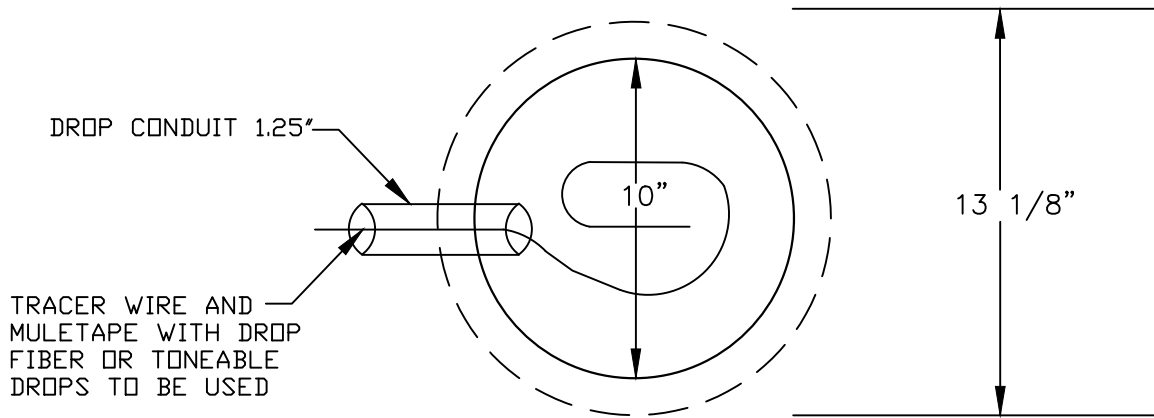

FLOWER POT

30"x48" PC UNIT, 2PC TIER 15/22
 18", 24", and 36" HEIGHT



AMERICAN POLYMER COMPANY

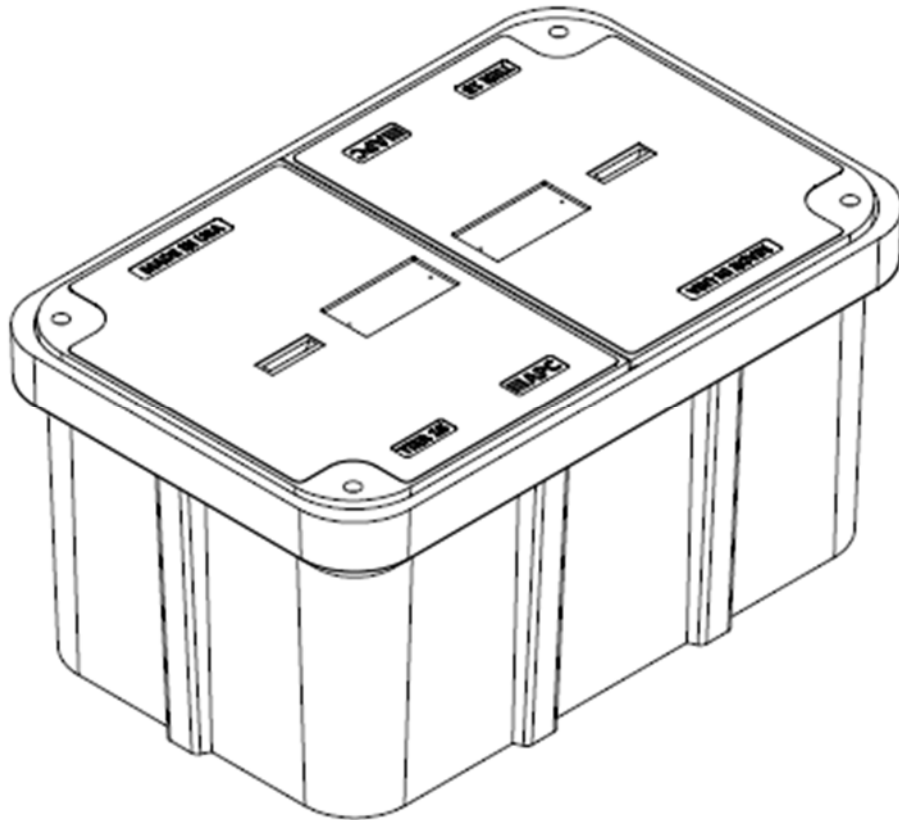

Description	Nominal Size	ANSI Tier	Part Number	Estimated Weight
PC Unit – TIER 15	30"x48"x18"	Tier 15	P304818HU15...	460 lbs.
PC Unit – TIER 22	30"x48"x18"	Tier 22	P304818HU22...	525 lbs.
PC Unit – TIER 15	30"x48"x24"	Tier 15	P304824HU15...	510 lbs.
PC Unit – TIER 22	30"x48"x24"	Tier 22	P304824HU22...	575 lbs.
PC Unit – TIER 15	30"x48"x36"	Tier 15	P304836HU15...	615 lbs.
PC Unit – TIER 22	30"x48"x36"	Tier 22	P304836HU22...	680 lbs.



30"x48" PC UNIT, 2PC TIER 15/22

18", 24", and 36" HEIGHT



AMERICAN POLYMER COMPANY

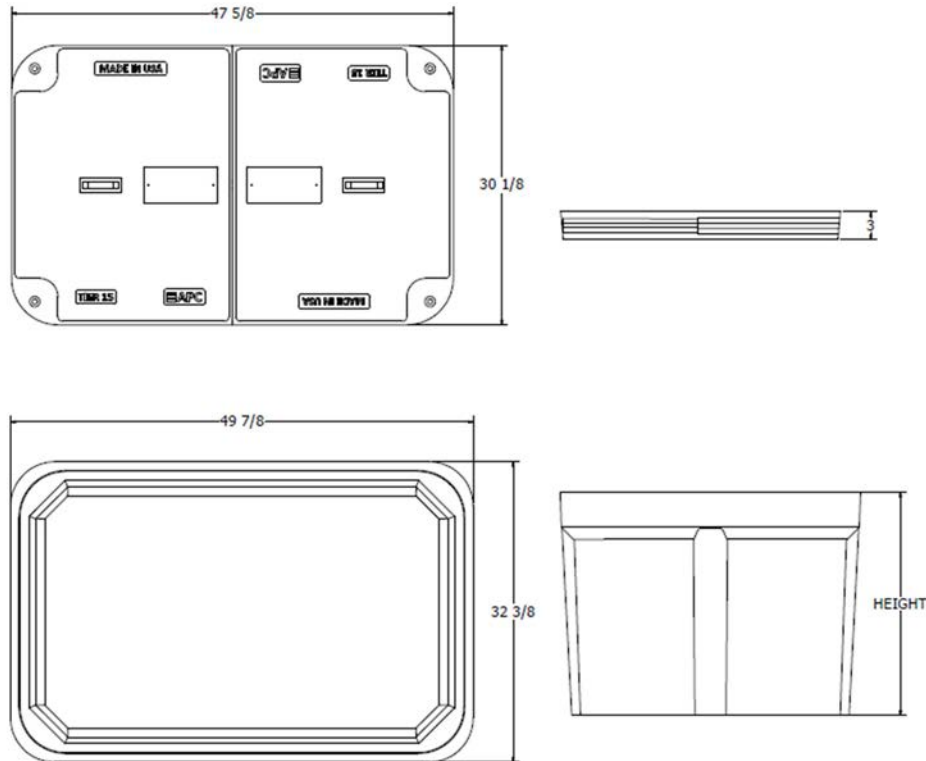

Components	Nominal Size	ANSI Tier	Part Number	Estimated Weight
Replacement Box	30"x48"x18"	Tier 22	P304818B22	185 lbs.
Replacement Box	30"x48"x24"	Tier 22	P304824B22	235 lbs.
Replacement Box	30"x48"x36"	Tier 22	P304836B22	340 lbs.
Replacement Lids - T15	30"x48" (half)	Tier 15	Various	150 lbs.
Replacement Lids - T22	30"x48" (half)	Tier 22	Various	170 lbs.

Bolt options



Machine Thread



Auger Thread



24"x36" PC UNIT, TIER 15/22
 18", 24", 30", and 36" HEIGHT



AMERICAN POLYMER COMPANY

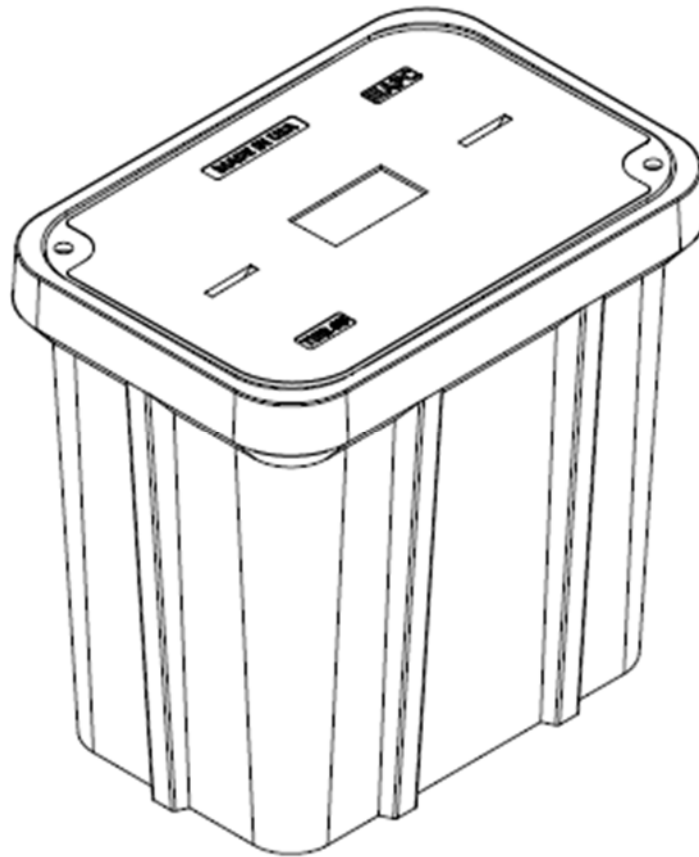

Description	Nominal Size	ANSI Tier	Part Number	Estimated Weight
PC Unit – TIER 15	24x36"x18"	Tier 15	P243618U15...	335 lbs.
PC Unit – TIER 22	24x36"x18"	Tier 22	P243618U22...	355 lbs.
PC Unit – TIER 15	24x36"x24"	Tier 15	P243624U15...	365 lbs.
PC Unit – TIER 22	24x36"x24"	Tier 22	P243624U22...	385 lbs.
PC Unit – TIER 15	24x36"x30"	Tier 15	P243630U15...	395 lbs.
PC Unit – TIER 22	24x36"x30"	Tier 22	P243630U22...	415 lbs.
PC Unit – TIER 15	24x36"x36"	Tier 15	P243636U15...	425 lbs.
PC Unit – TIER 22	24x36"x36"	Tier 22	P243636U22...	445 lbs.



24"x36" PC UNIT, TIER 15/22

18", 24", 30", and 36" HEIGHT



AMERICAN POLYMER COMPANY

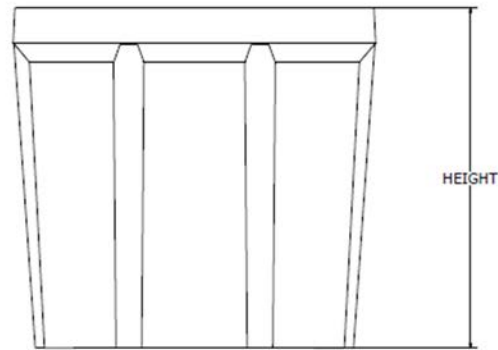
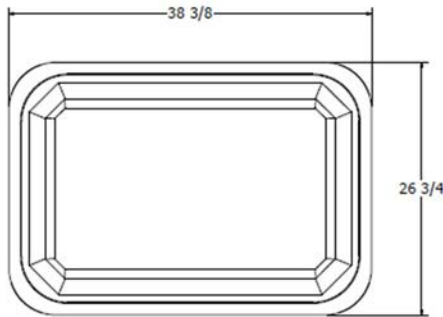
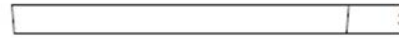
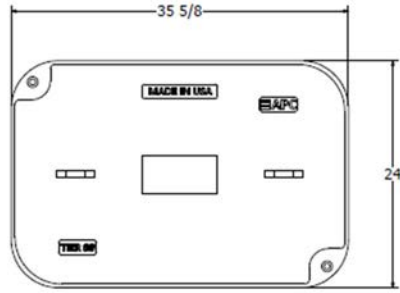

Components	Nominal Size	ANSI Tier	Part Number	Estimated Weight
Replacement Box	24"x36"x18"	Tier 22	P243618B22	165 lbs.
Replacement Box	24"x36"x24"	Tier 22	P243624B22	195 lbs.
Replacement Box	24"x36"x30"	Tier 22	P243630B22	225 lbs.
Replacement Box	24"x36"x36"	Tier 22	P243636B22	255 lbs.
Replacement Lids - T15	24"x36"	Tier 15	Various	170 lbs.
Replacement Lids - T22	24"x36"	Tier 22	Various	190 lbs.

Bolt options

Hex Head



Machine Thread



Penta Head



Auger Thread



17"x30" PC UNIT, TIER 15/22

12", 18", 24", and 30" HEIGHT



AMERICAN POLYMER COMPANY

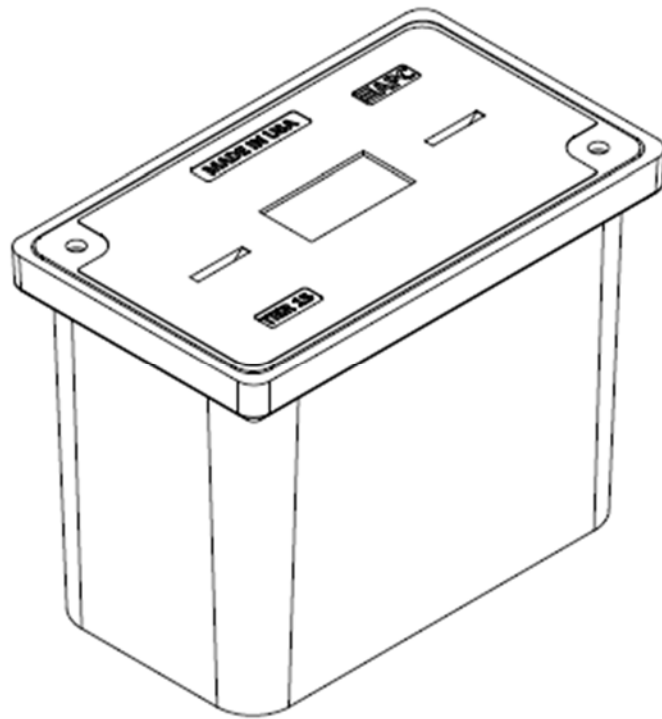

Description	Nominal Size	ANSI Tier	Part Number	Estimated Weight
PC Unit - TIER 15	17"x30"x12"	Tier 15	P173012U15...	138 lbs.
PC Unit - TIER 22	17"x30"x12"	Tier 22	P173012U22...	147 lbs.
PC Unit - TIER 15	17"x30"x18"	Tier 15	P173018U15...	172 lbs.
PC Unit - TIER 22	17"x30"x18"	Tier 22	P173018U22...	181 lbs.
PC Unit - TIER 15	17"x30"x24"	Tier 15	P173024U15...	192 lbs.
PC Unit - TIER 22	17"x30"x24"	Tier 22	P173024U22...	201 lbs.
PC Unit - TIER 15	17"x30"x30"	Tier 15	P173030U15...	217 lbs.
PC Unit - TIER 22	17"x30"x30"	Tier 22	P173030U22...	226 lbs.



17"x30" PC UNIT, TIER 15/22

12", 18", 24", and 30" HEIGHT



AMERICAN POLYMER COMPANY

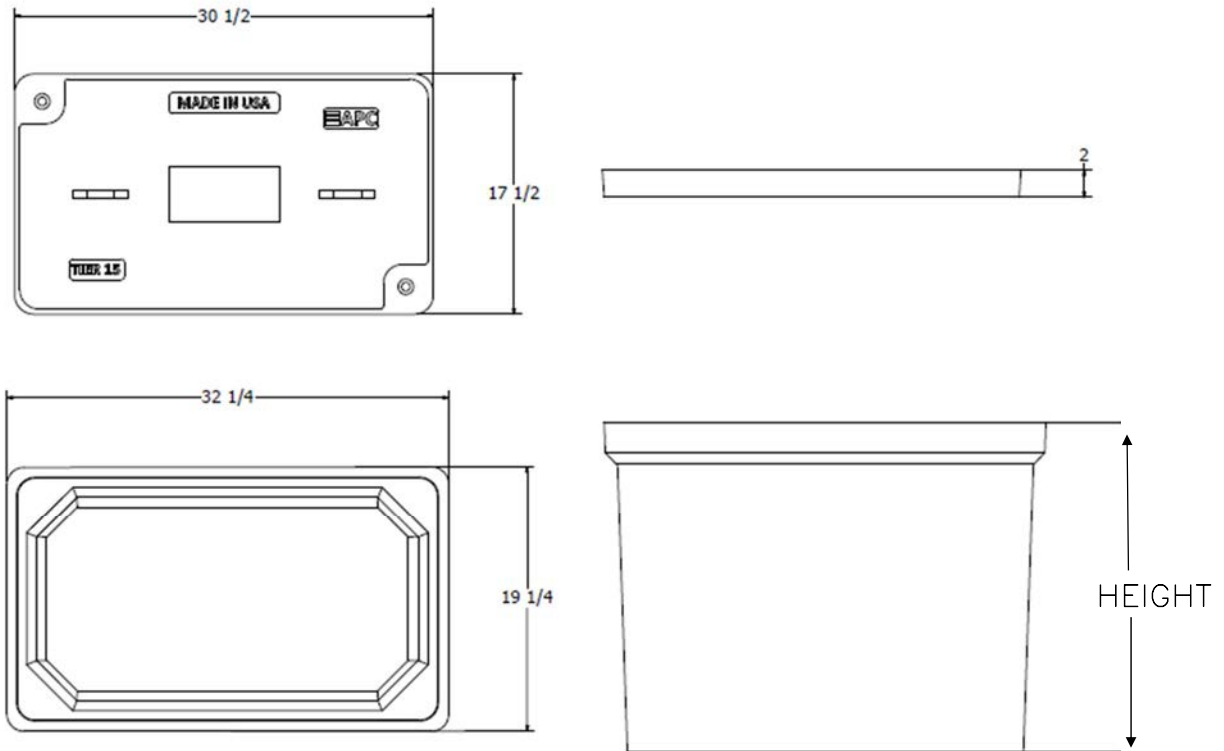

Components	Nominal Size	ANSI Tier	Part Number	Estimated Weight
Replacement Box	17"x30"x12"	Tier 22	P173012B22	66 lbs.
Replacement Box	17"x30"x18"	Tier 22	P173018B22	100 lbs.
Replacement Box	17"x30"x24"	Tier 22	P173024B22	120 lbs.
Replacement Box	17"x30"x30"	Tier 22	P173030B22	145 lbs.
Replacement Lids - T15	17"x30"	Tier 15	Various	72 lbs.
Replacement Lids - T22	17"x30"	Tier 22	Various	81 lbs.

Bolt options



Machine Thread



Auger Thread



33"x60" PC UNIT, 2PC TIER 15/22
36" HEIGHT



AMERICAN POLYMER COMPANY

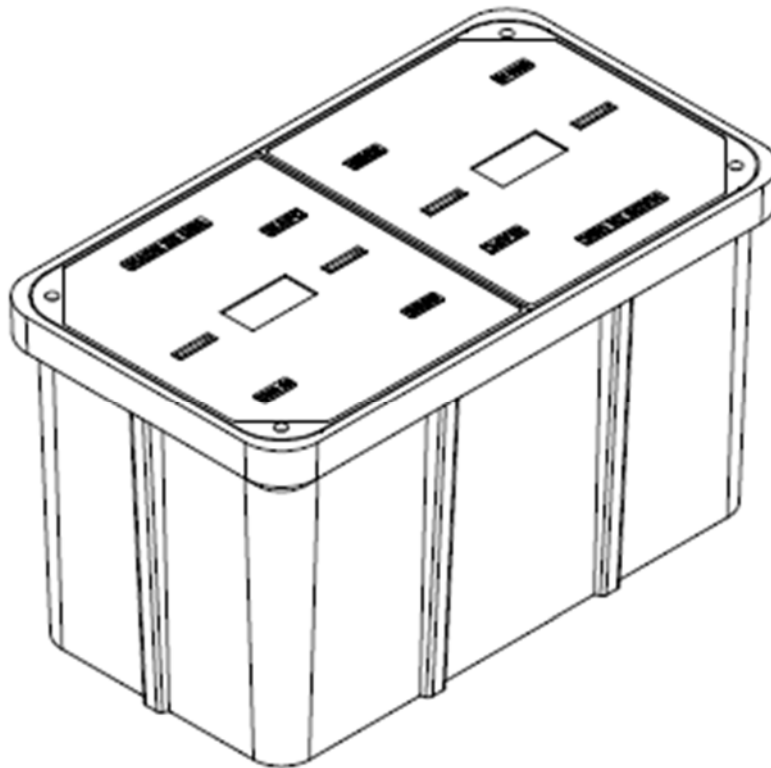

Description	Nominal Size	ANSI Tier	Part Number	Estimated Weight
PC Unit - TIER 15	33"x60"x36"	Tier 15	P336036U15...	930 lbs.
PC Unit - TIER 22	33"x60"x36"	Tier 22	P336036U22...	1030 lbs.



33"x60" PC UNIT, 2PC TIER 15/22

36" HEIGHT



AMERICAN POLYMER COMPANY

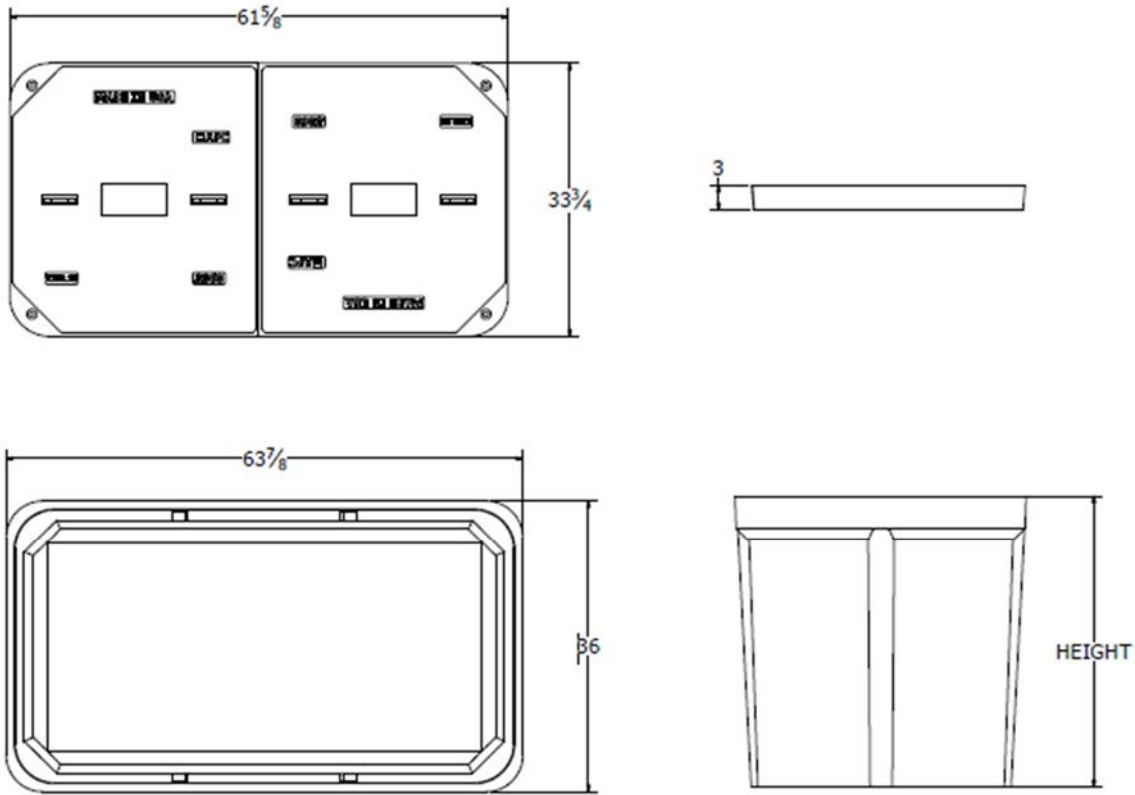

Components	Nominal Size	ANSI Tier	Part Number	Estimated Weight
Replacement Box	33"x60"x36"	Tier 22	P336036B22	530 lbs.
Replacement Lids - T15	33"x60" (half)	Tier 15	Various	200 lbs.
Replacement Lids - T22	33"x60" (half)	Tier 22	Various	250 lbs.

Bolt options

Hex Head



Machine Thread



Penta Head



Auger Thread



Speed (MPH) Prior To Road Work	SIGN SPACING, FT.		Must be Approved by an Engineer				
	Non-Divided Highways	Divided Highways	BUFFER SPACE, FT.	TAPER LENGTH, FT.	CHANNELIZING SPACING, FT.		
	Length	Shoulder (10 ft. Width)	Lane (12 ft. Width)	Through Taper	Through Buffer/Work Area	Through Buffer/Work Area	
0-35	200	200	250	70	245	35	50
40-45	350	500	360	150	540	40	80
50-55	500	1000	495	185	660	50	100
60-70	SA-1000, SB-1500, SC-2640		730	235	840	60	120
	Urban Low Speed - 100 FT						

APPROVED/ACCEPTED BY:
ENGINEER, OWNER, or PRIME CONTRACTOR
 Check for Notice to Proceed.
BLN01b-F12_N Hay St-TCP1

Signature: _____

Company: _____

Road Runner Safety Services, Inc.

Date: 3/8/2023 Project: BLN01b-F12 N Hay St-TCP1 :
Traffic Control Suggestion For: AEG :
By: Road Runner Safety Services, Inc. : Nathan

Comments:
Drawing not to scale. Traffic control plan must be approved by an engineer. This is a suggestion only. Road Runners Safety Services, Inc. has no liability for this suggested traffic control plan. Actual placement and spacing of all traffic control devices will depend on field conditions and must conform to MUTCD standards.

- Legend**
- ADA Barricade
 - Channelizer
 - Conduit
 - Flagger (Person)
 - Overhead Strand
 - Sign
 - Vault
 - Work Area

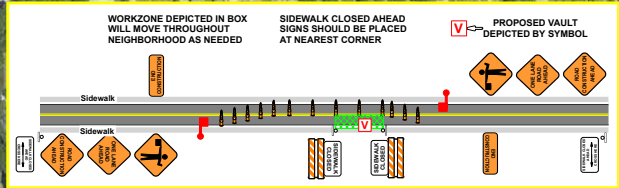

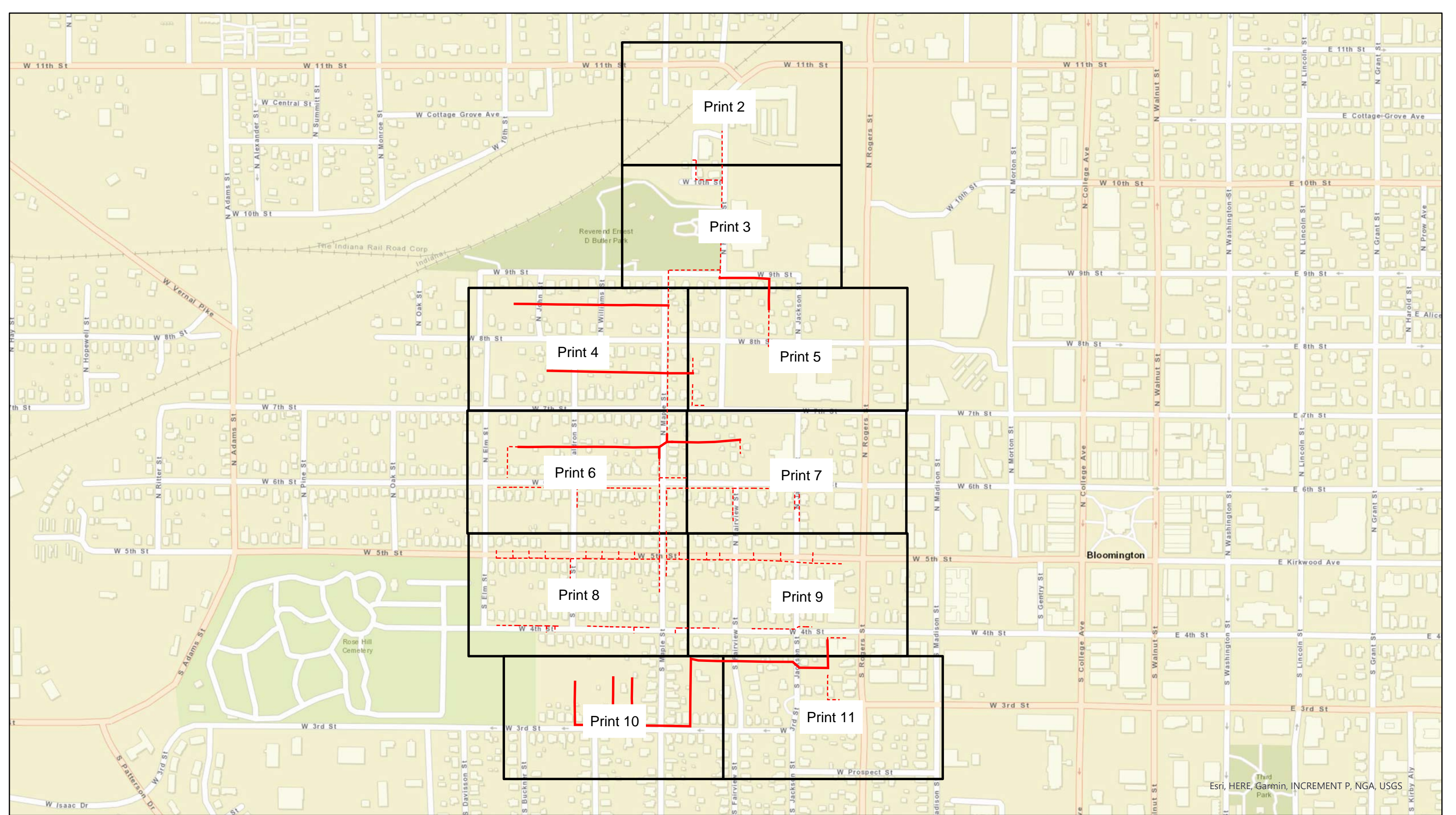

Esri, HERE, Garmin, INCREMENT P, NGA, USGS



Legend BLN01b-F11_N Williams St

- Overhead Strand
- - - Conduit
- Grids

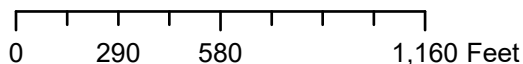

City of Bloomington, IN Permit:
Design View

INI	BY	DATE	DESCRIPTION



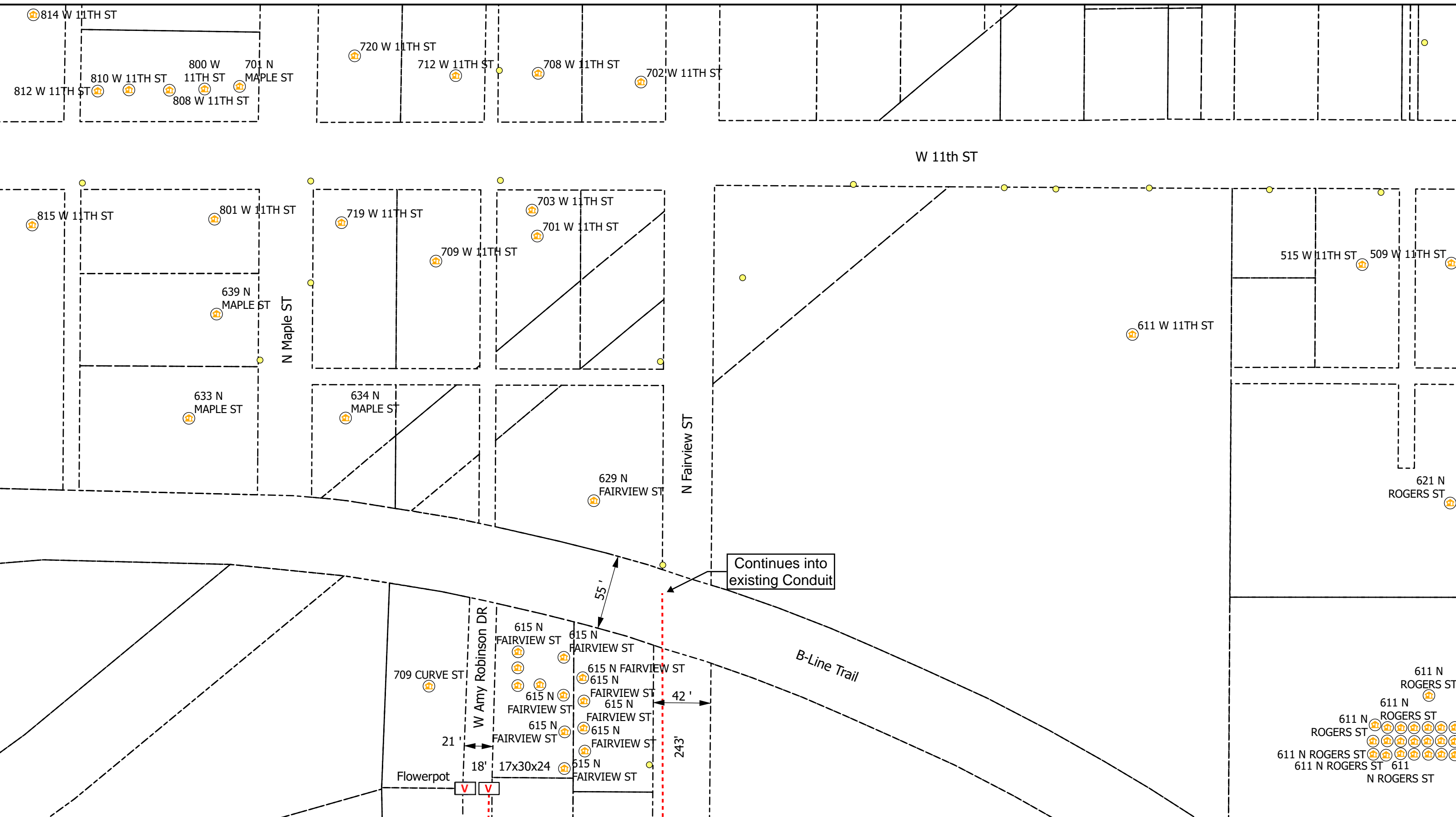

- Legend**
- Poles
 - Risers
 - Sidewalk
 - Vaults
 - Address
 - Anchor
 - Overhead Strand
 - Conduit
 - Bloomington_Parcels
 - Grids

All Flowerpots 12" DIA



City of Bloomington, IN Permit:
Design View

INI	BY	DATE	DESCRIPTION



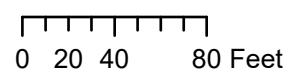
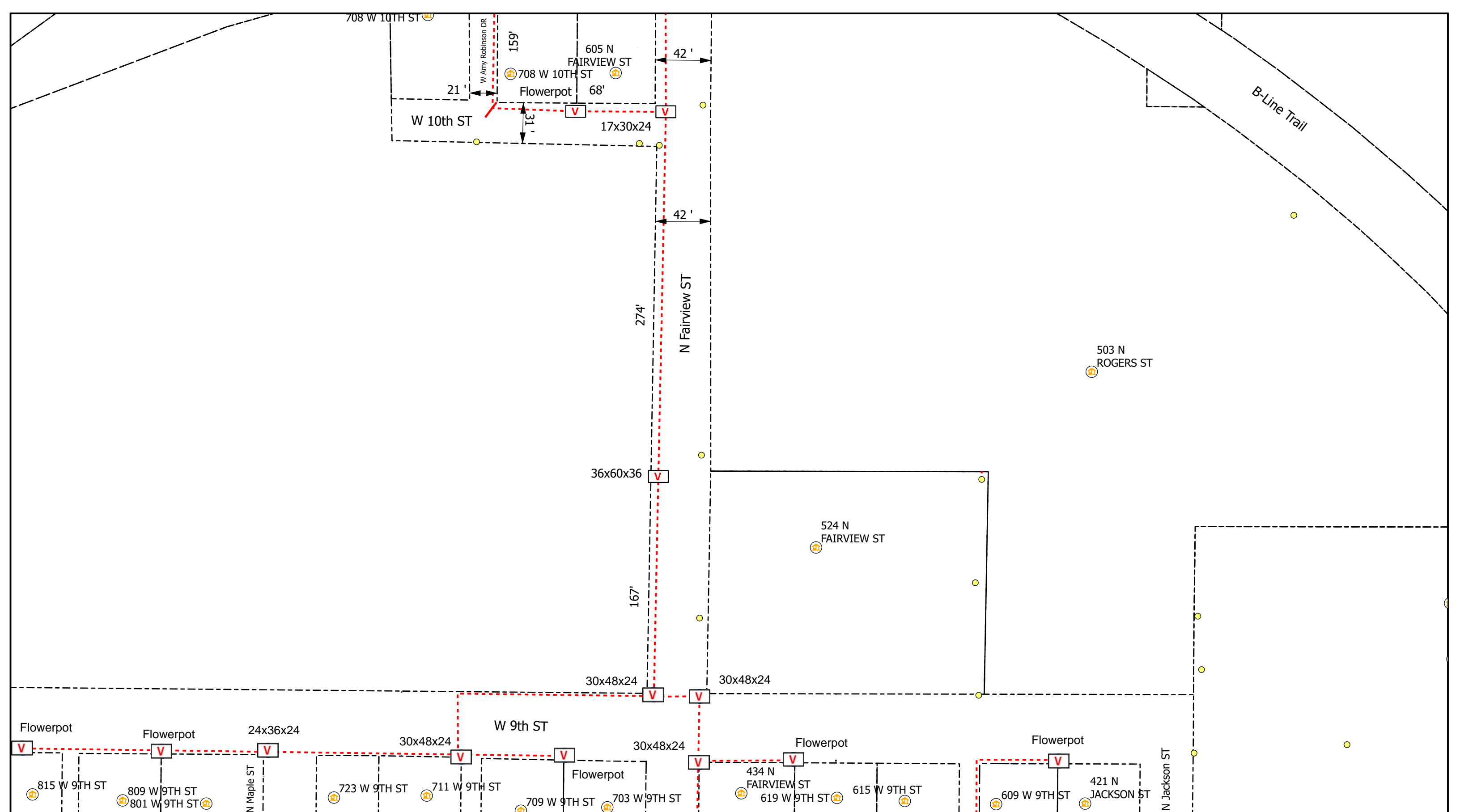

Legend

- Poles
- V Vaults
- Overhead Strand
- Conduit
- R Risers
- A Address
- Y Anchor
- ↖ Sidewalk
- Bloomington_Parcels
- Grids

All Flowerpots 12" DIA



City of Bloomington, IN Permit:
Design View

INI	BY	DATE	DESCRIPTION



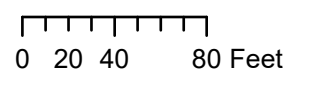
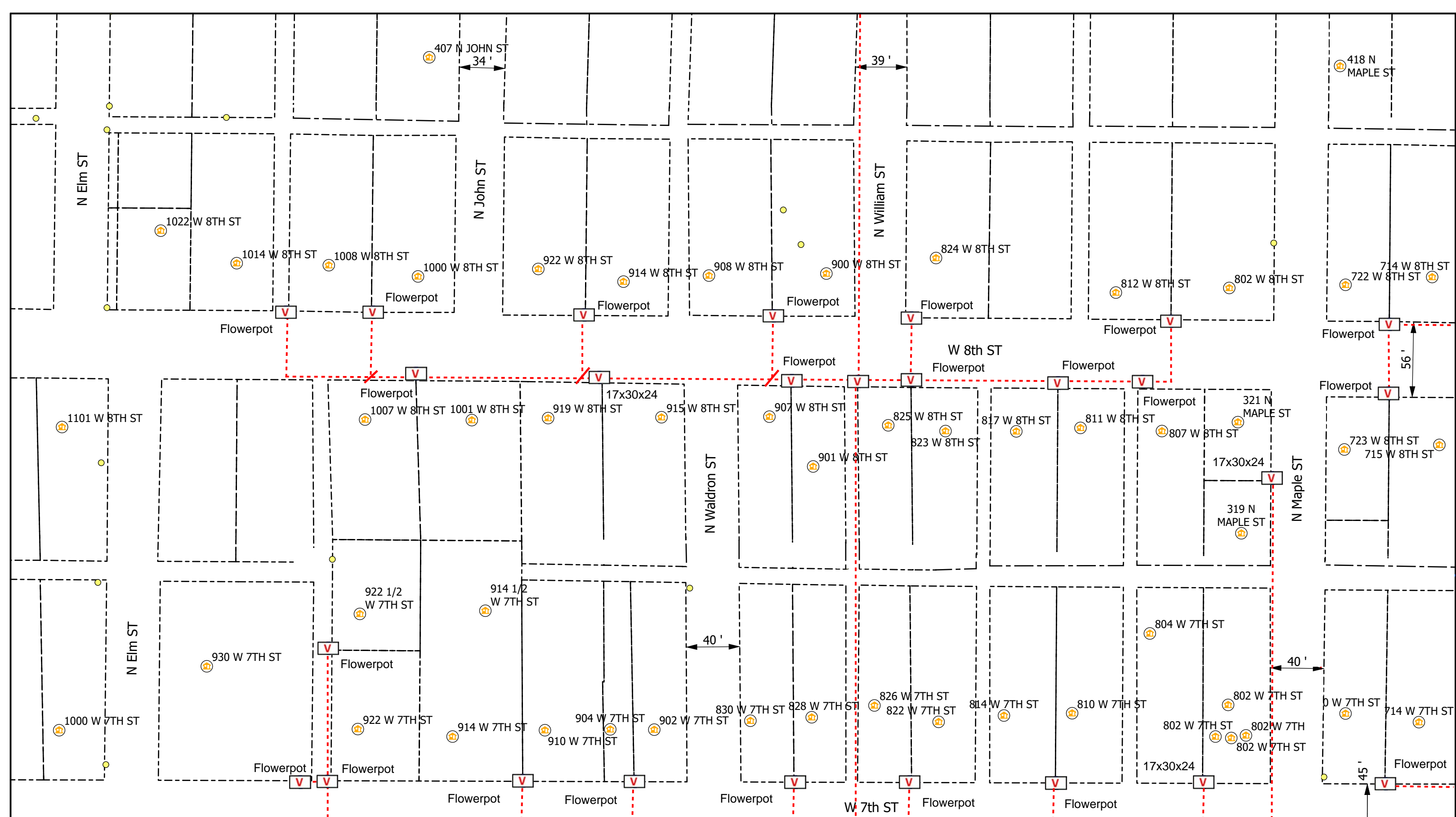

Legend

- Poles
- Risers
- Sidewalk
- Vaults
- Address
- Bloomington_Parcels
- Overhead Strand
- Anchor
- Conduit
- Grids

All Flowerpots 12" DIA



City of Bloomington, IN Permit:
Design View

INI	BY	DATE	DESCRIPTION



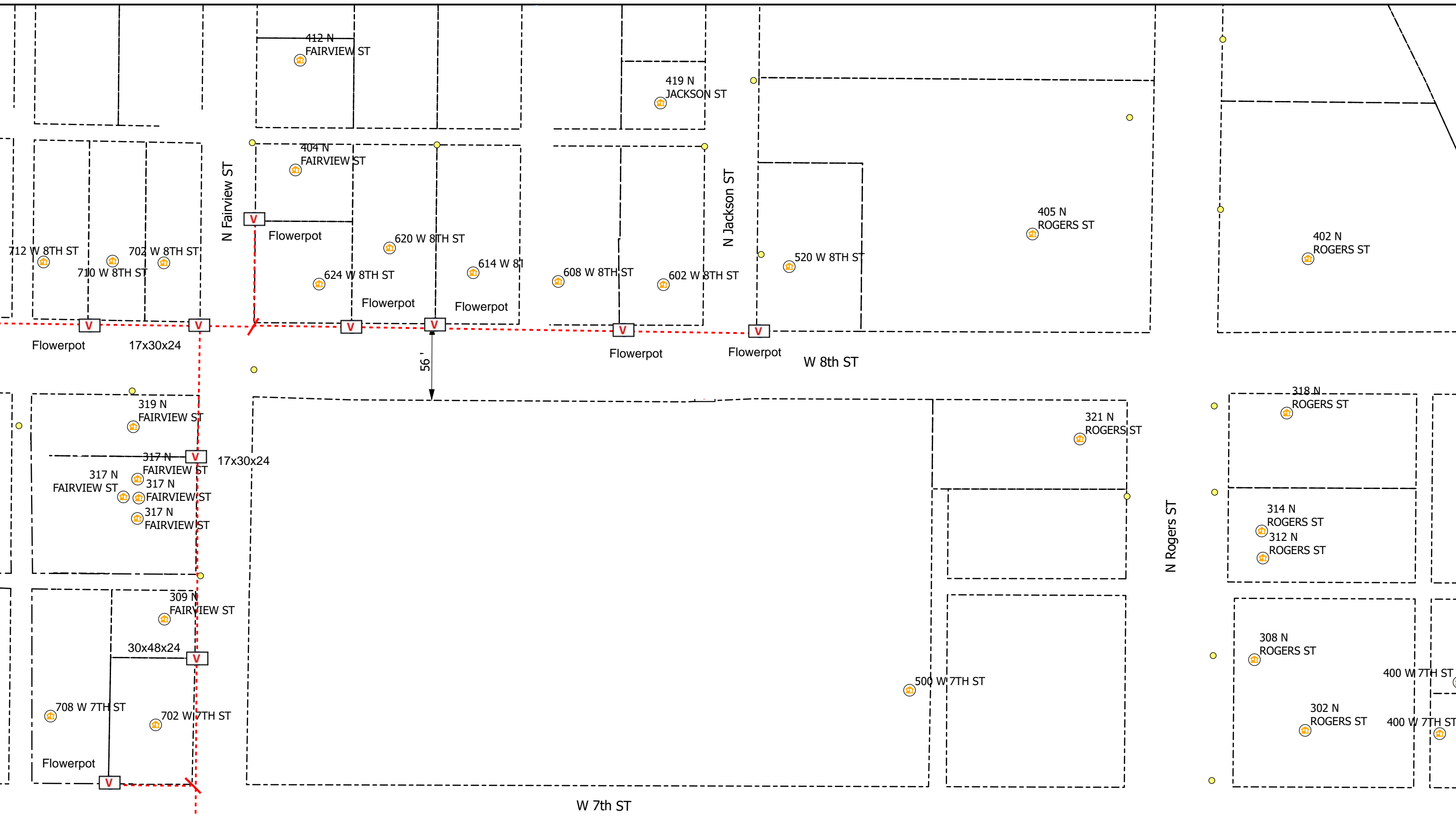

Legend

- Poles
- V Vaults
- Overhead Strand
- Conduit
- R Risers
- Ⓜ Address
- Y Anchor
- ↖ Sidewalk
- Bloomington_Parcels
- Grids

All Flowerpots 12" DIA



City of Bloomington, IN Permit:
Design View

INI	BY	DATE	DESCRIPTION



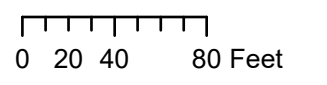
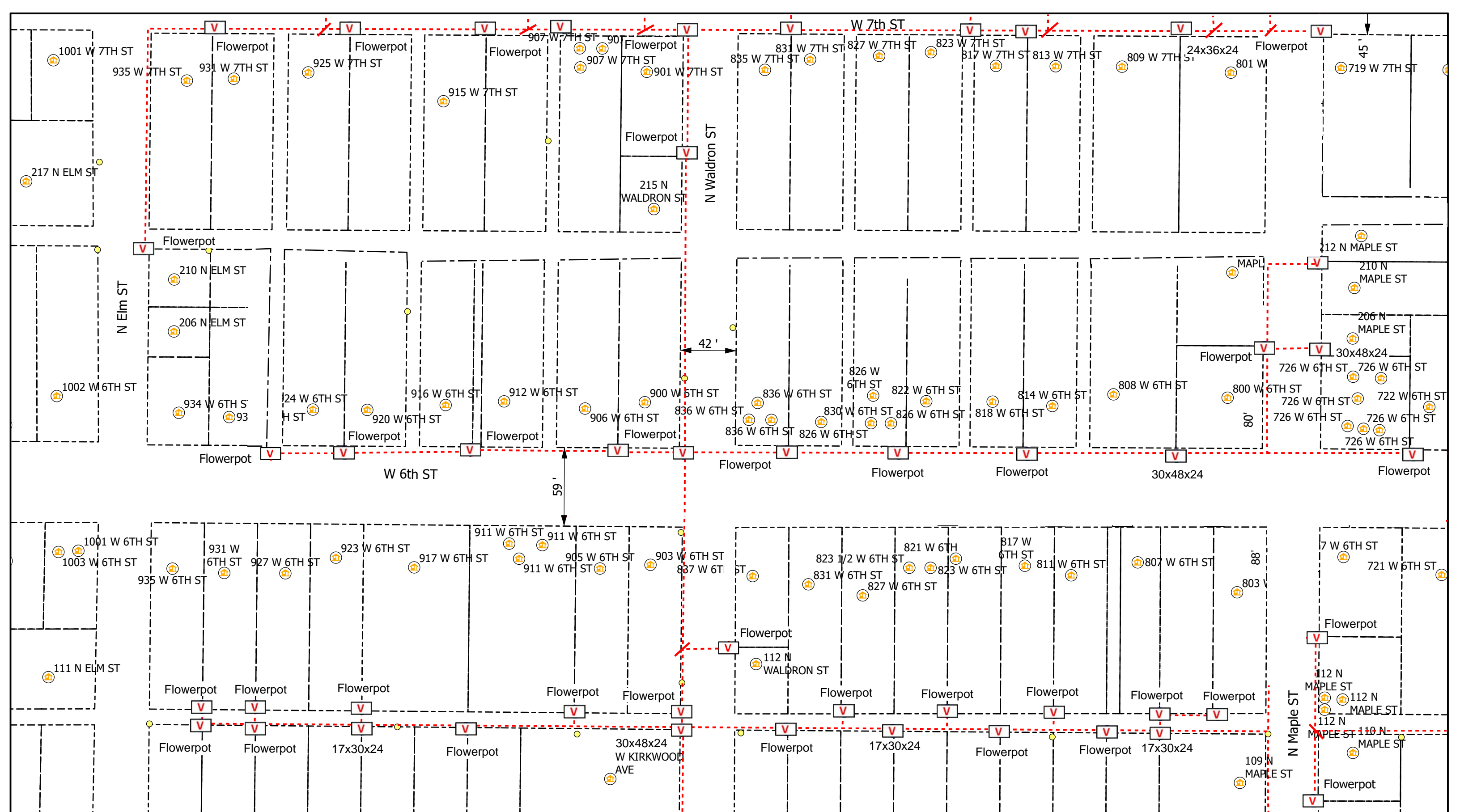

Legend

- Poles
- V Vaults
- Overhead Strand
- Conduit
- Ⓡ Risers
- 🏠 Address
- Y Anchor
- ↖ Sidewalk
- Bloomington_Parcels
- Grids

All Flowerpots 12" DIA



City of Bloomington, IN Permit:
Design View

INI	BY	DATE	DESCRIPTION



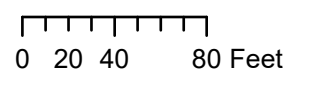
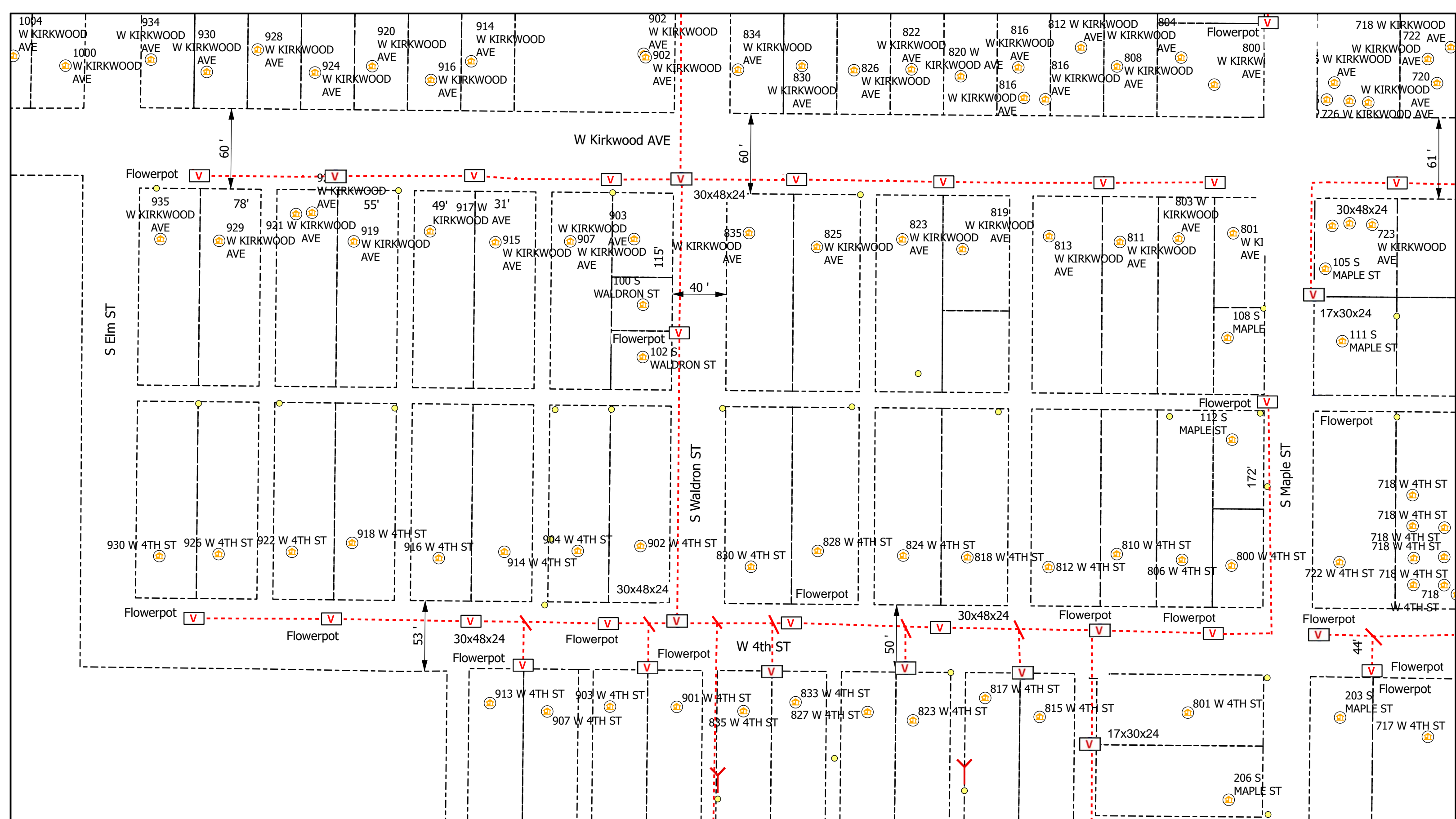

Legend

- Poles
- Ⓡ Risers
- Ⓜ Vaults
- Overhead Strand
- - - Conduit
- 🏠 Address
- ⌵ Anchor
- ↩ Sidewalk
- Bloomington_Parcels
- Grids

All Flowerpots 12" DIA



City of Bloomington, IN Permit:
Design View

INI	BY	DATE	DESCRIPTION



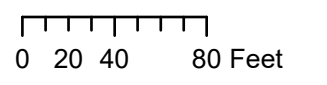
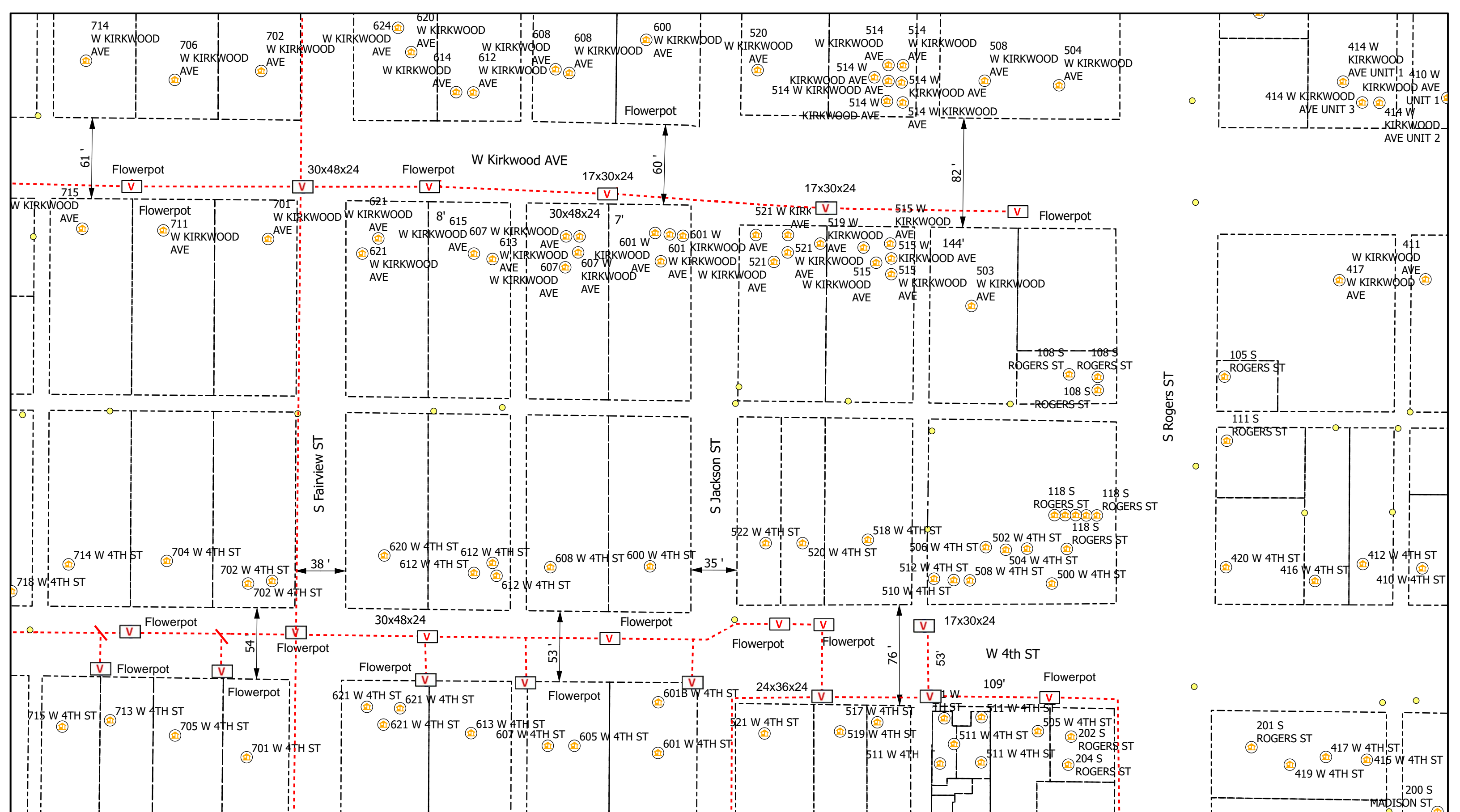

Legend

- Poles
- Risers
- Vaults
- Overhead Strand
- Conduit
- Address
- Anchor
- Sidewalk
- Bloomington_Parcels
- Grids

All Flowerpots 12" DIA



City of Bloomington, IN Permit:
Design View

INI	BY	DATE	DESCRIPTION



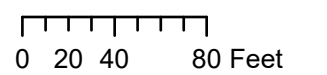
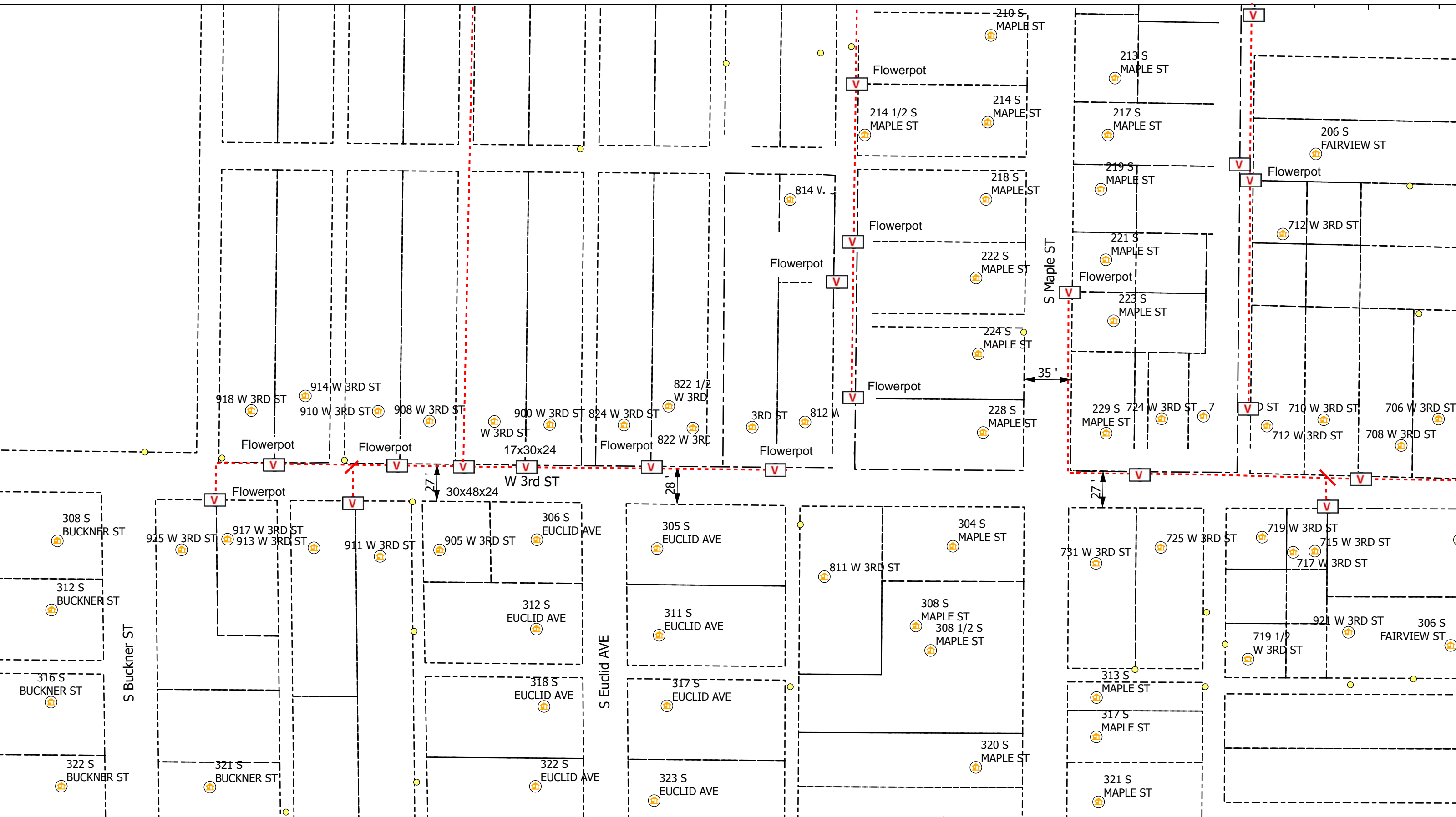

Legend

- Poles
- V Vaults
- Overhead Strand
- Conduit
- R Risers
- 🏠 Address
- Y Anchor
- ↖ Sidewalk
- Bloomington_Parcels
- Grids

All Flowerpots 12" DIA



City of Bloomington, IN Permit:
Design View

INI	BY	DATE	DESCRIPTION



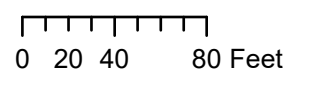
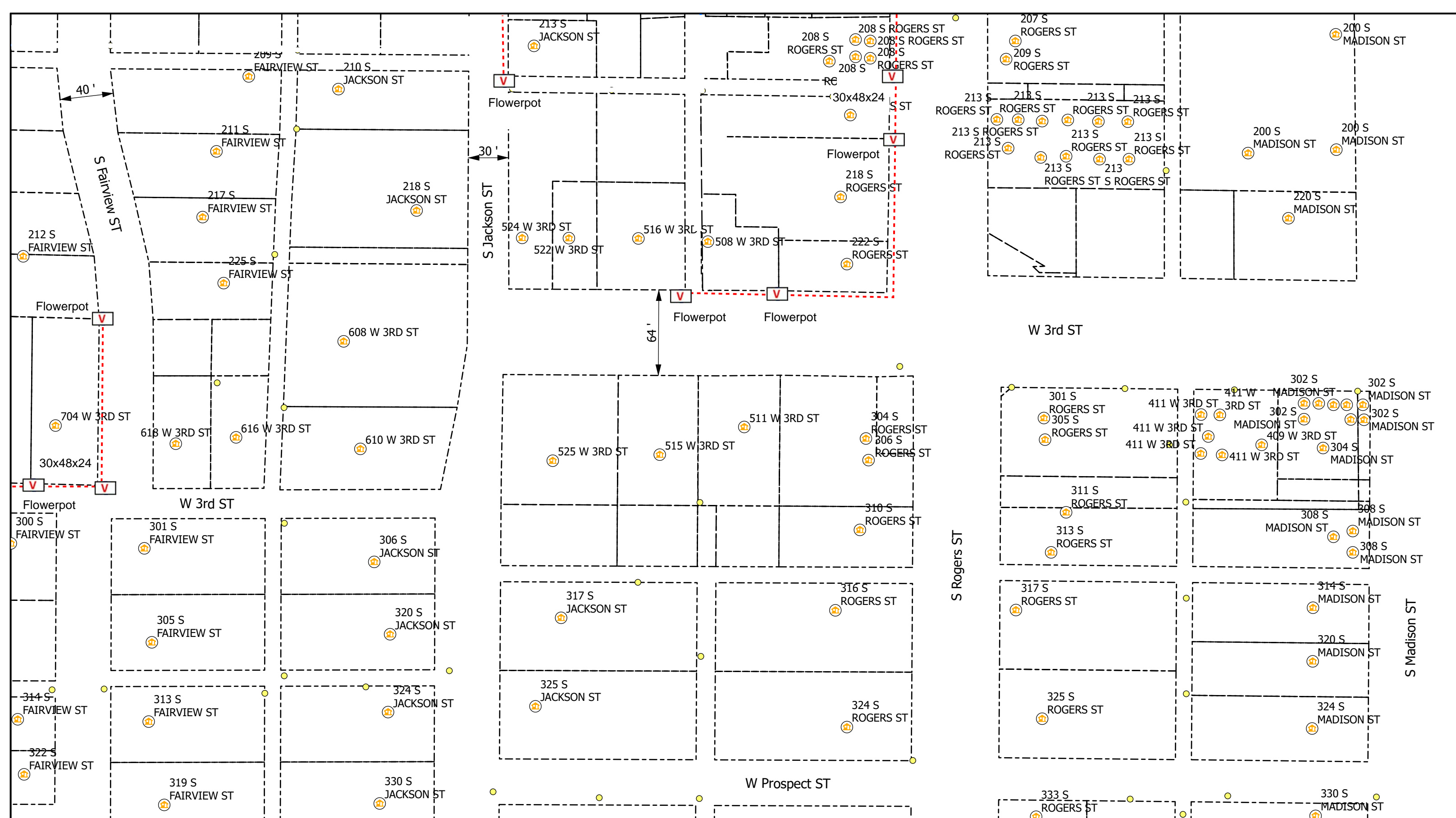

Legend

- Poles
- V Vaults
- Overhead Strand
- - - Conduit
- Ⓡ Risers
- 🏠 Address
- Y Anchor
- ↖ Sidewalk
- Bloomington_Parcels
- Grids

All Flowerpots 12" DIA



City of Bloomington, IN Permit:
Design View

INI	BY	DATE	DESCRIPTION



Carlton® PV-Mold® Nonmetallic Pole Riser System

Carlton PV-Mold is a nonmetallic pole riser system designed to protect communications power cable installed on poles.

Features:

- Meets or exceeds requirements outlined in the National Electric Safety Code (NESC).
- Designed in accordance with NEMA TC-19 specifications.
- Ultraviolet, cold temperature and corrosive atmosphere resistant.
- Schedule 40 wall meets Schedule 80 PVC conduit impact requirements per NEMA TC-19.
- No grounding required.
- Belled end fits over each added section or conduit.
- Flame retardant.
- Requires no maintenance.
- PV-Mold acts as an insulator against electrical shock.
- Interchangeable parts and accessories to match the needs of specific requirements.



Steel U-Guard requires grounding strapping and does not have belled ends.



PV-Mold has belled ends, flanged design and does not require grounding.

Flanged Overall Length 10 Feet, Including Bell

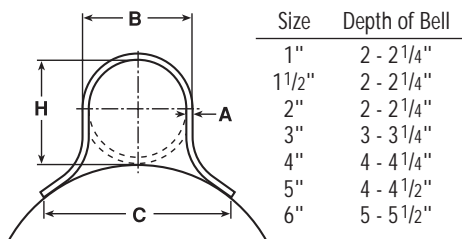

Slots are 1/2" from side to side, and allow for expansion and contraction.

Slot Dimensions: for sizes 2" through 6" are 5/16" wide, 3/4" long.

Slot Dimensions: for 1" and 1 1/2" are 3/16" wide, 3/4" long.

Slot Spacing: 18" from center, beginning 6" from end.

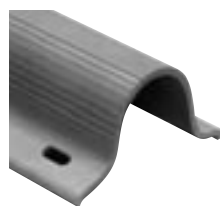

Standard Duty

Part No.	Size	Std. Ctn. Qty.	Std. Ctn. Wt. (lbs.)	Dimensions				Actual Impact @ 0°C 20 Pound Top
				A	B	C	H	
59208N	1"	294	1059	0.100"	1 5/8"	2 3/8"	1 5/8"	40 Ft.-Lbs.
59211N	2"	136	726	0.100"	2 3/8"	4 1/2"	2 3/8"	100 Ft.-Lbs.
59211X (5' length)	2"	136	363	0.100"	2 3/8"	4 1/2"	2 3/8"	100 Ft.-Lbs.
59213N	3"	66	761	0.150"	3 1/2"	6"	3 1/2"	110 Ft.-Lbs.
59213X (5' length)	3"	66	381	0.150"	3 1/2"	6"	3 1/2"	100 Ft.-Lbs.
59215N	4"	65	910	0.150"	4 1/2"	6 1/2"	4 1/2"	110 Ft.-Lbs.
59216N	5"	30	515	0.150"	5 1/2"	7 1/2"	5 1/2"	110 Ft.-Lbs.

Heavy Duty Schedule 40

59010N	1 1/2"	200	1142	0.145"	1 29/32"	3 1/2"	1 29/32"	100 Ft.-Lbs.
59011N	2"	136	1214	0.154"	2 3/8"	4 1/2"	2 3/8"	150 Ft.-Lbs.
59013N	3"	66	937	0.216"	3 1/2"	6"	3 9/32"	150 Ft.-Lbs.
59015N	4"	65	1621	0.237"	4 1/2"	6 1/2"	4 1/2"	260 Ft.-Lbs.
59015X (5' length)	4"	65	707	0.237"	4 1/2"	6 1/2"	4 1/2"	260 Ft.-Lbs.
59016N	5"	30	870	0.258"	5 1/2"	7 1/2"	5 1/2"	260 Ft.-Lbs.
59017N	6"	30	1160	0.280"	6 5/8"	8 3/4"	6 5/8"	260 Ft.-Lbs.

Extra Heavy Duty Schedule 80

59411N	2"	136	1549	0.218"	2 3/8"	4 1/2"	2 3/8"	300 Ft.-Lbs.
59413N	3"	66	1495	0.030"	3 1/2"	6"	3 1/2"	525 Ft.-Lbs.

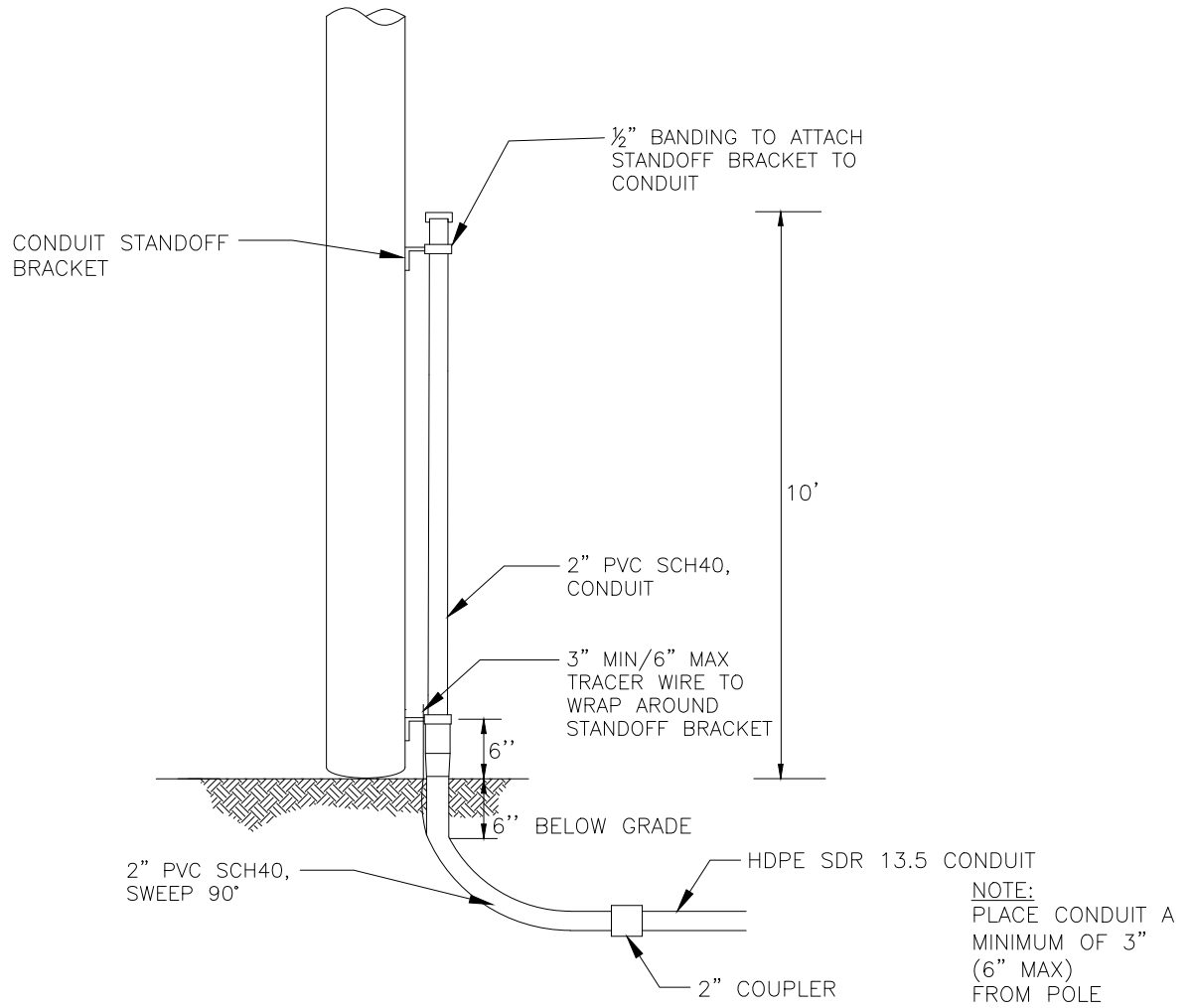

DESCRIPTION	QTY	MANUFACTURER (PREFERRED)	PART #
SCREW, LAG, 1/2" x 4-1/2"	10		
HDPE SDR 13.5 CONDUIT, VARIOUS SIZES	N/A		
2" PVC SCH40, RISER PIPE	1		
#12 TRACER WIRE	N/A		
2" PVC SCH40, SWEEP, 90 DEG	1		
CONDUIT STANDOFF BRACKET	VARIES		
CONDUIT STRAP KIT	VARIES		
2" COUPLER	1		



TYPICAL RISER
CONDUIT
WOOD POLE

(R2-W)

CONCEPTUAL SIDE VIEW

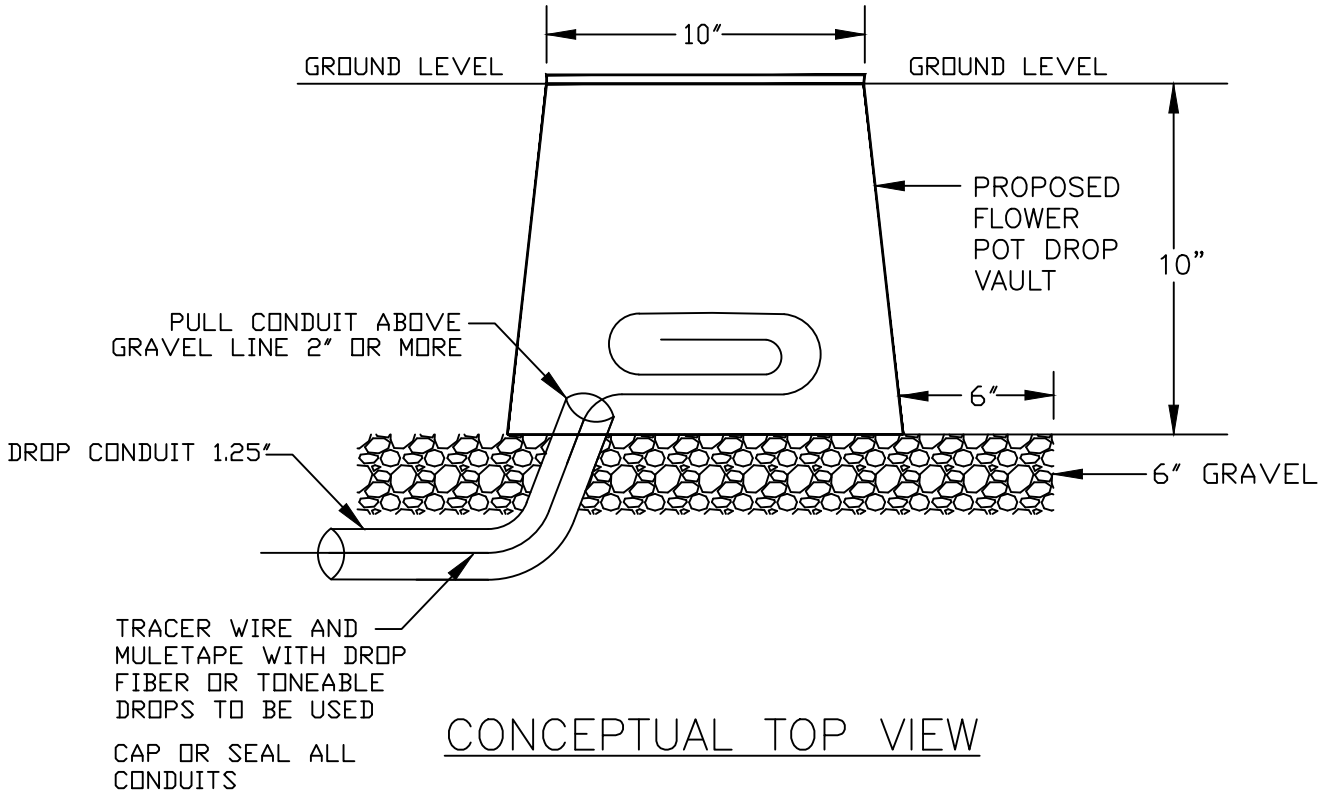

CONCEPTUAL TOP VIEW

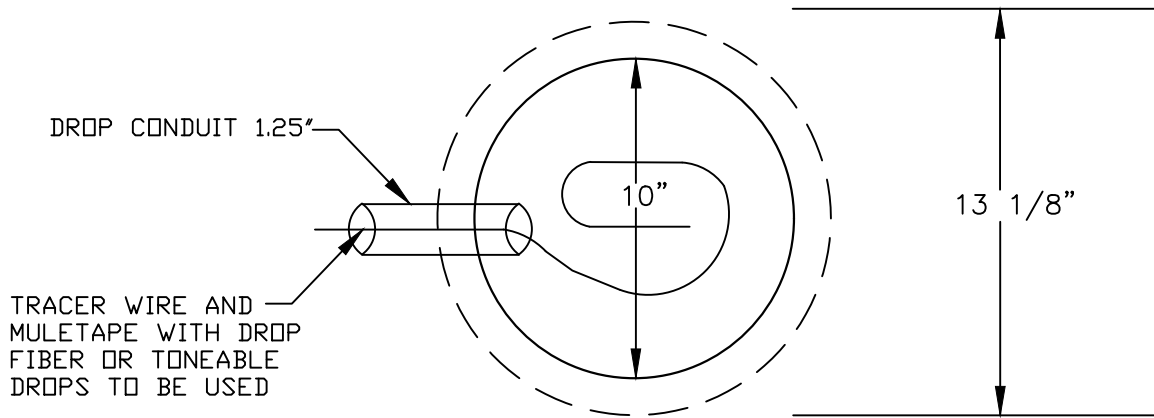

FLOWER POT

30"x48" PC UNIT, 2PC TIER 15/22
 18", 24", and 36" HEIGHT



AMERICAN POLYMER COMPANY

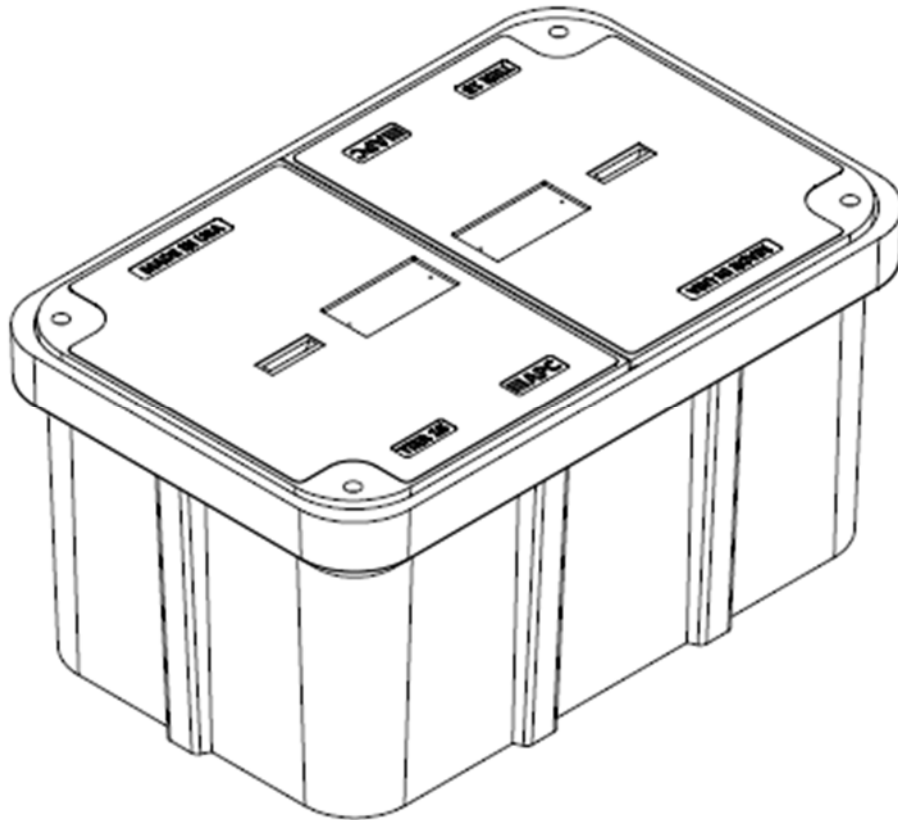

Description	Nominal Size	ANSI Tier	Part Number	Estimated Weight
PC Unit – TIER 15	30"x48"x18"	Tier 15	P304818HU15...	460 lbs.
PC Unit – TIER 22	30"x48"x18"	Tier 22	P304818HU22...	525 lbs.
PC Unit – TIER 15	30"x48"x24"	Tier 15	P304824HU15...	510 lbs.
PC Unit – TIER 22	30"x48"x24"	Tier 22	P304824HU22...	575 lbs.
PC Unit – TIER 15	30"x48"x36"	Tier 15	P304836HU15...	615 lbs.
PC Unit – TIER 22	30"x48"x36"	Tier 22	P304836HU22...	680 lbs.



30"x48" PC UNIT, 2PC TIER 15/22

18", 24", and 36" HEIGHT



AMERICAN POLYMER COMPANY

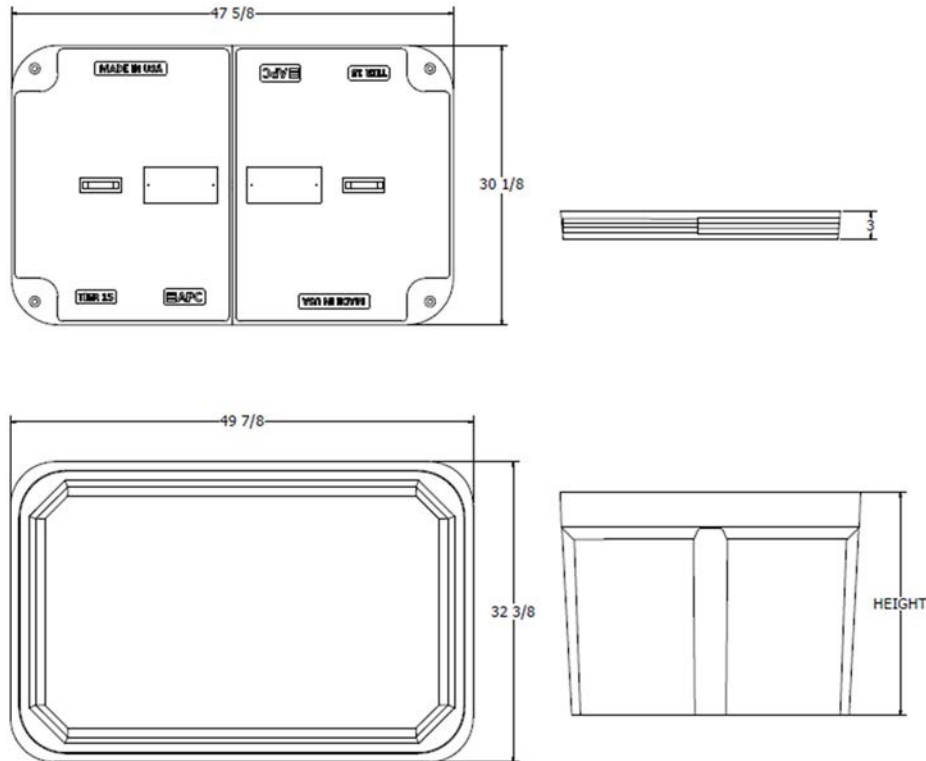

Components	Nominal Size	ANSI Tier	Part Number	Estimated Weight
Replacement Box	30"x48"x18"	Tier 22	P304818B22	185 lbs.
Replacement Box	30"x48"x24"	Tier 22	P304824B22	235 lbs.
Replacement Box	30"x48"x36"	Tier 22	P304836B22	340 lbs.
Replacement Lids - T15	30"x48" (half)	Tier 15	Various	150 lbs.
Replacement Lids - T22	30"x48" (half)	Tier 22	Various	170 lbs.

Bolt options



Machine Thread



Auger Thread



24"x36" PC UNIT, TIER 15/22
 18", 24", 30", and 36" HEIGHT



AMERICAN POLYMER COMPANY

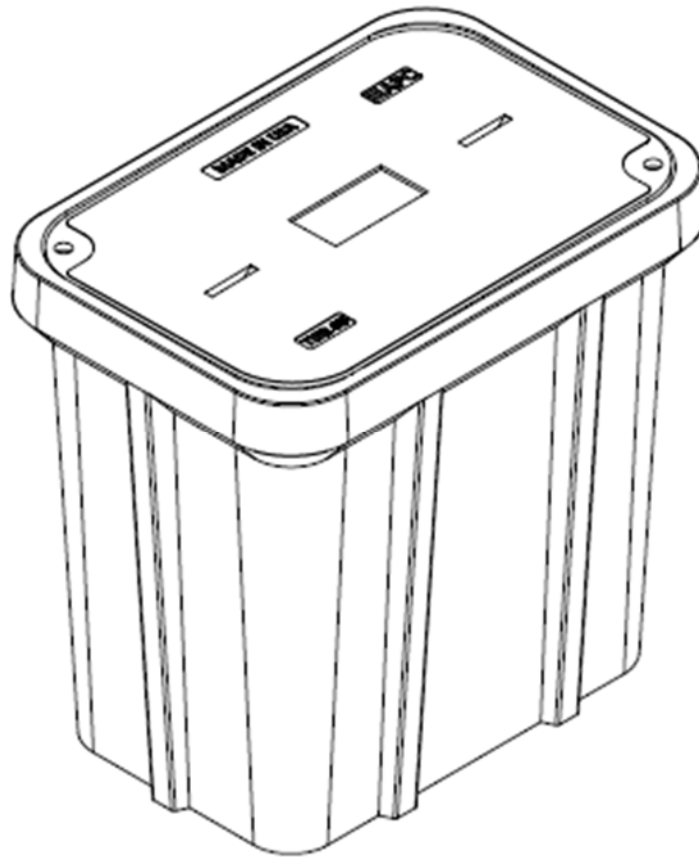

Description	Nominal Size	ANSI Tier	Part Number	Estimated Weight
PC Unit – TIER 15	24x36"x18"	Tier 15	P243618U15...	335 lbs.
PC Unit – TIER 22	24x36"x18"	Tier 22	P243618U22...	355 lbs.
PC Unit – TIER 15	24x36"x24"	Tier 15	P243624U15...	365 lbs.
PC Unit – TIER 22	24x36"x24"	Tier 22	P243624U22...	385 lbs.
PC Unit – TIER 15	24x36"x30"	Tier 15	P243630U15...	395 lbs.
PC Unit – TIER 22	24x36"x30"	Tier 22	P243630U22...	415 lbs.
PC Unit – TIER 15	24x36"x36"	Tier 15	P243636U15...	425 lbs.
PC Unit – TIER 22	24x36"x36"	Tier 22	P243636U22...	445 lbs.



24"x36" PC UNIT, TIER 15/22

18", 24", 30", and 36" HEIGHT



AMERICAN POLYMER COMPANY

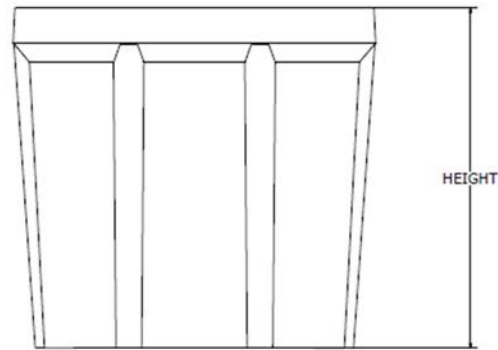
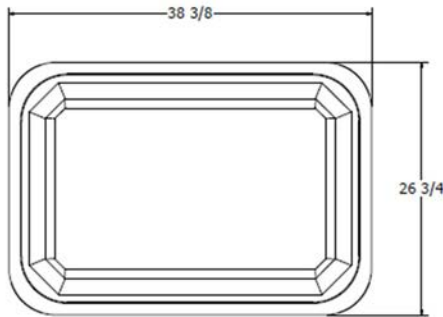
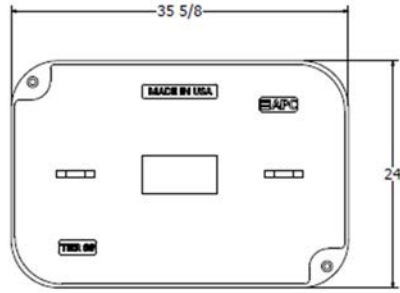

Components	Nominal Size	ANSI Tier	Part Number	Estimated Weight
Replacement Box	24"x36"x18"	Tier 22	P243618B22	165 lbs.
Replacement Box	24"x36"x24"	Tier 22	P243624B22	195 lbs.
Replacement Box	24"x36"x30"	Tier 22	P243630B22	225 lbs.
Replacement Box	24"x36"x36"	Tier 22	P243636B22	255 lbs.
Replacement Lids - T15	24"x36"	Tier 15	Various	170 lbs.
Replacement Lids - T22	24"x36"	Tier 22	Various	190 lbs.

Bolt options

Hex Head



Machine Thread



Penta Head



Auger Thread



17"x30" PC UNIT, TIER 15/22

12", 18", 24", and 30" HEIGHT



AMERICAN POLYMER COMPANY

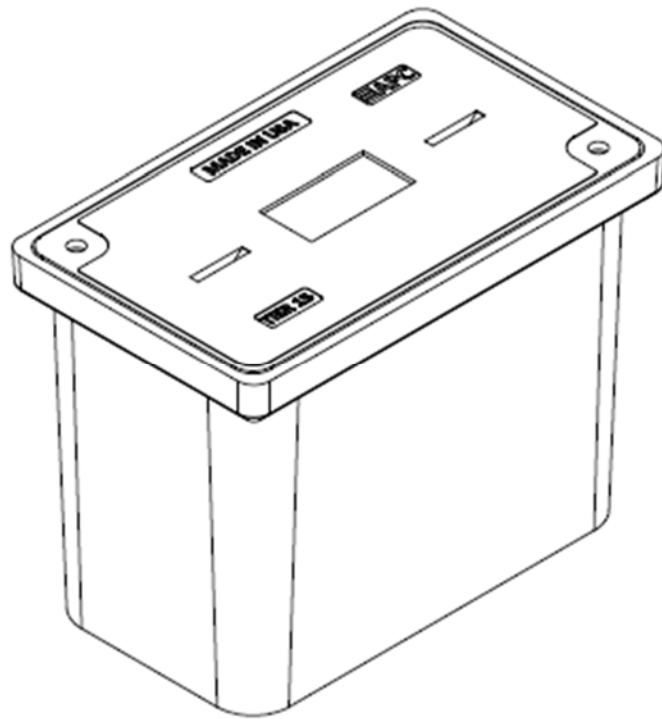

Description	Nominal Size	ANSI Tier	Part Number	Estimated Weight
PC Unit – TIER 15	17"x30"x12"	Tier 15	P173012U15...	138 lbs.
PC Unit – TIER 22	17"x30"x12"	Tier 22	P173012U22...	147 lbs.
PC Unit – TIER 15	17"x30"x18"	Tier 15	P173018U15...	172 lbs.
PC Unit – TIER 22	17"x30"x18"	Tier 22	P173018U22...	181 lbs.
PC Unit – TIER 15	17"x30"x24"	Tier 15	P173024U15...	192 lbs.
PC Unit – TIER 22	17"x30"x24"	Tier 22	P173024U22...	201 lbs.
PC Unit – TIER 15	17"x30"x30"	Tier 15	P173030U15...	217 lbs.
PC Unit – TIER 22	17"x30"x30"	Tier 22	P173030U22...	226 lbs.



17"x30" PC UNIT, TIER 15/22

12", 18", 24", and 30" HEIGHT



AMERICAN POLYMER COMPANY

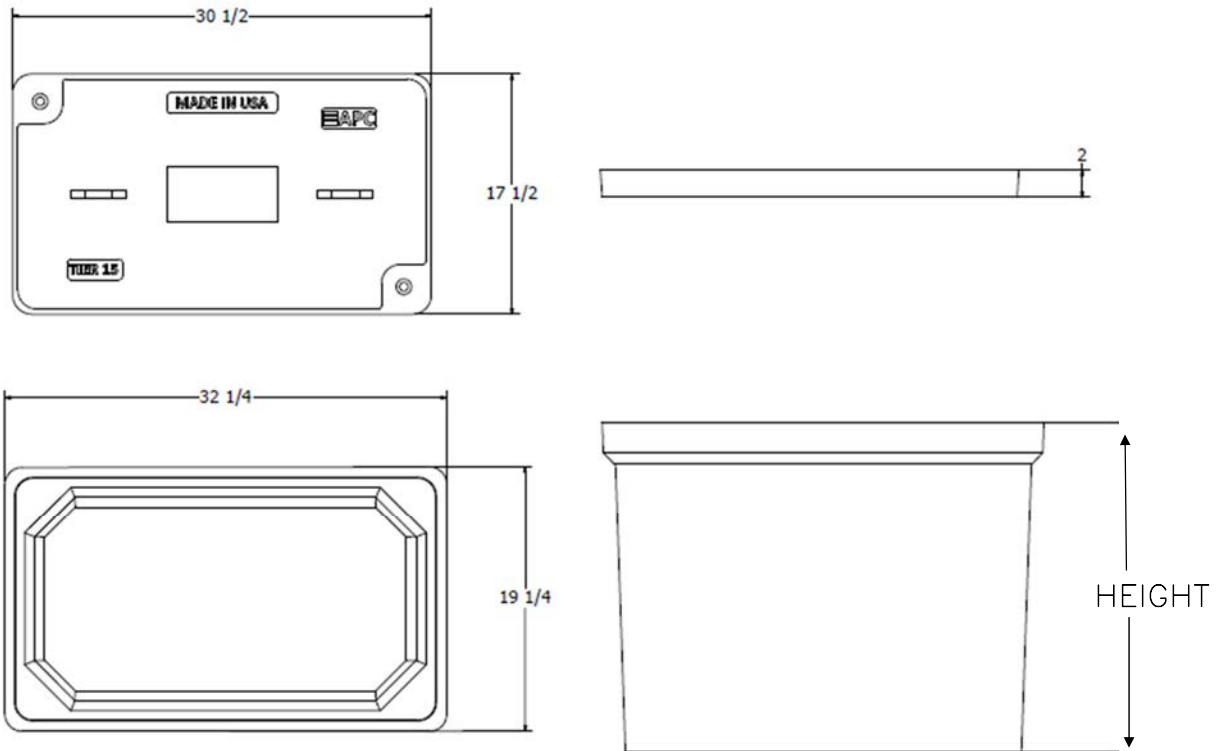

Components	Nominal Size	ANSI Tier	Part Number	Estimated Weight
Replacement Box	17"x30"x12"	Tier 22	P173012B22	66 lbs.
Replacement Box	17"x30"x18"	Tier 22	P173018B22	100 lbs.
Replacement Box	17"x30"x24"	Tier 22	P173024B22	120 lbs.
Replacement Box	17"x30"x30"	Tier 22	P173030B22	145 lbs.
Replacement Lids - T15	17"x30"	Tier 15	Various	72 lbs.
Replacement Lids - T22	17"x30"	Tier 22	Various	81 lbs.

Bolt options



Machine Thread



Auger Thread



33"x60" PC UNIT, 2PC TIER 15/22
36" HEIGHT



AMERICAN POLYMER COMPANY

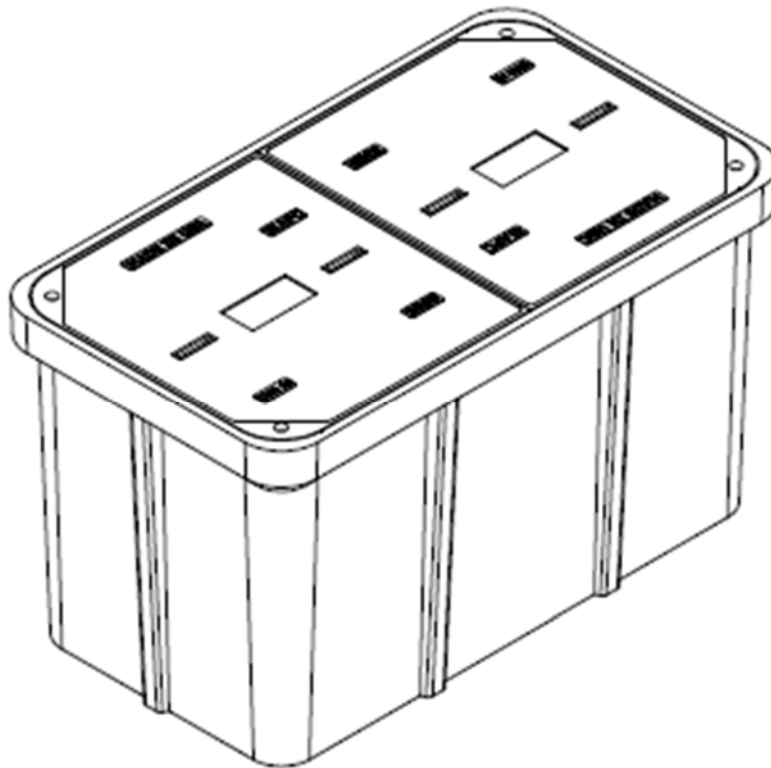

Description	Nominal Size	ANSI Tier	Part Number	Estimated Weight
PC Unit - TIER 15	33"x60"x36"	Tier 15	P336036U15...	930 lbs.
PC Unit - TIER 22	33"x60"x36"	Tier 22	P336036U22...	1030 lbs.



33"x60" PC UNIT, 2PC TIER 15/22

36" HEIGHT



AMERICAN POLYMER COMPANY

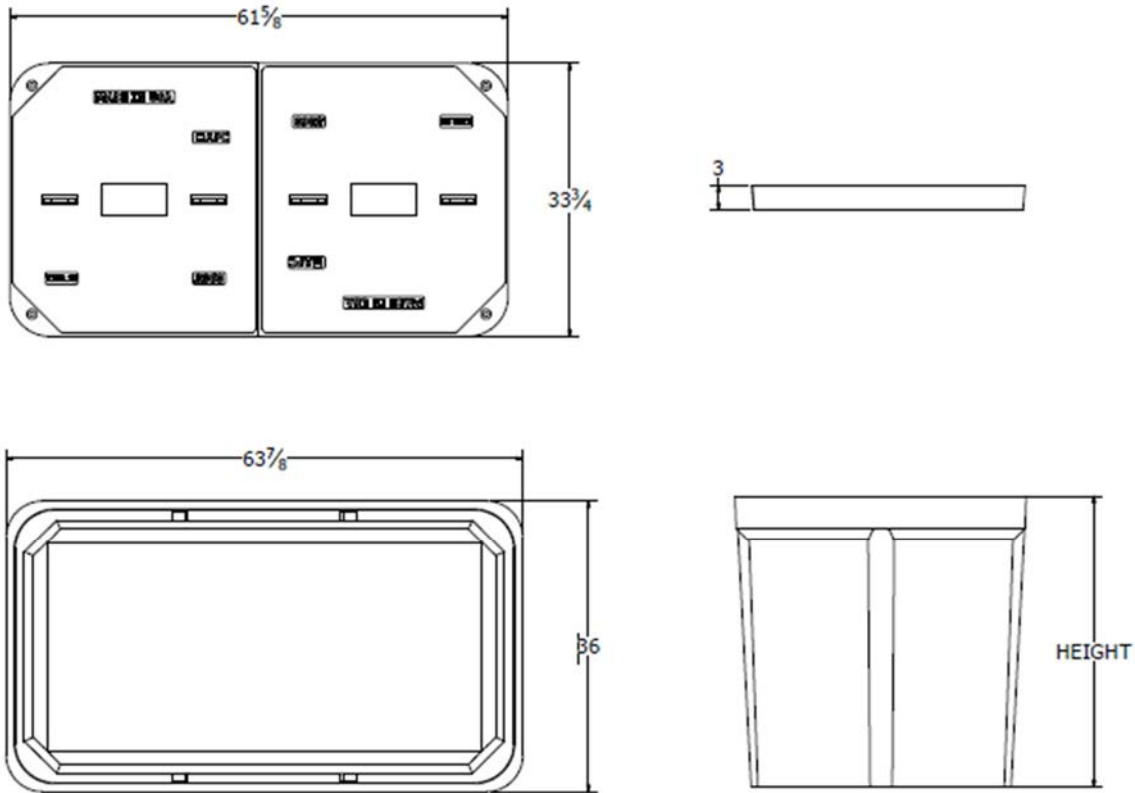

Components	Nominal Size	ANSI Tier	Part Number	Estimated Weight
Replacement Box	33"x60"x36"	Tier 22	P336036B22	530 lbs.
Replacement Lids - T15	33"x60" (half)	Tier 15	Various	200 lbs.
Replacement Lids - T22	33"x60" (half)	Tier 22	Various	250 lbs.

Bolt options

Hex Head



Machine Thread



Penta Head



Auger Thread



Speed (MPH) Prior To Road Work	SIGN SPACING, FT.		Must be Approved by an Engineer				
	Non-Divided Highways	Divided Highways	BUFFER SPACE, FT.	TAPER LENGTH, FT.	CHANNELIZING SPACING, FT.		
	Length	Shoulder (10 ft. Width)	Lane (12 ft. Width)	Through Taper	Through Buffer/Work Area		
0-35	200	200	250	70	245	35	50
40-45	350	500	360	150	540	40	80
50-55	500	1000	495	185	660	50	100
60-70	SA-1000, SB-1500, SC-2640		730	235	840	60	120
	Urban Low Speed - 100 FT						

APPROVED/ACCEPTED BY:
ENGINEER, OWNER, or PRIME CONTRACTOR
 Check for Notice to Proceed.

Signature: _____

Company: _____

Date: 12/7/2023 **Project:** BLN01b-F11 N Williams St TCP ;
Traffic Control Suggestion For: ATLANTIC ENGINEERING (AEG) ;
By: Road Runner Safety Services, Inc. : Nathan

Comments:
 Drawing not to scale. Traffic control plan must be approved by an engineer. This is a suggestion only. Road Runners Safety Services, Inc. has no liability for this suggested traffic control plan. Actual placement and spacing of all traffic control devices will depend on field conditions and must conform to MUTCD standards.

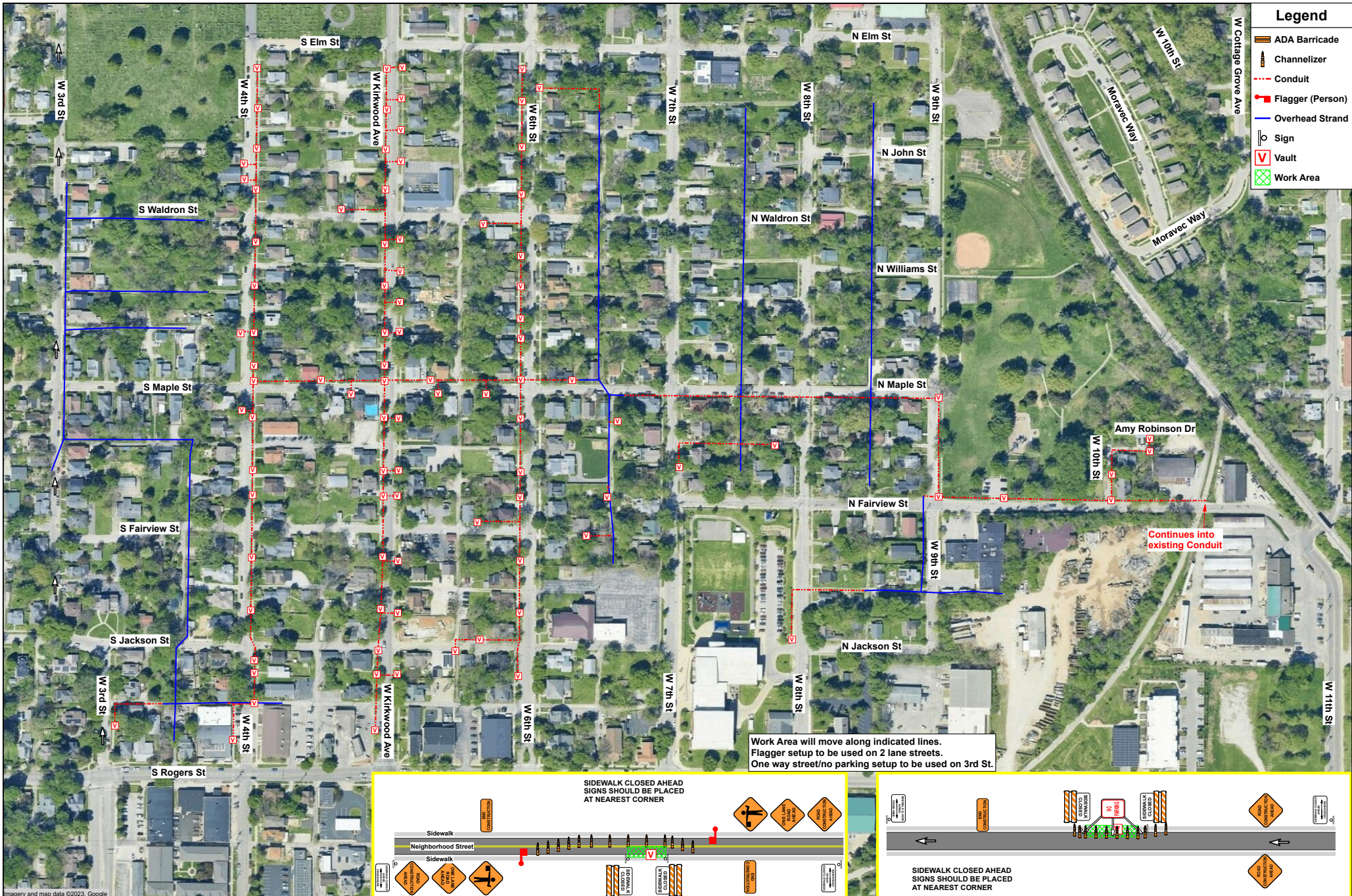

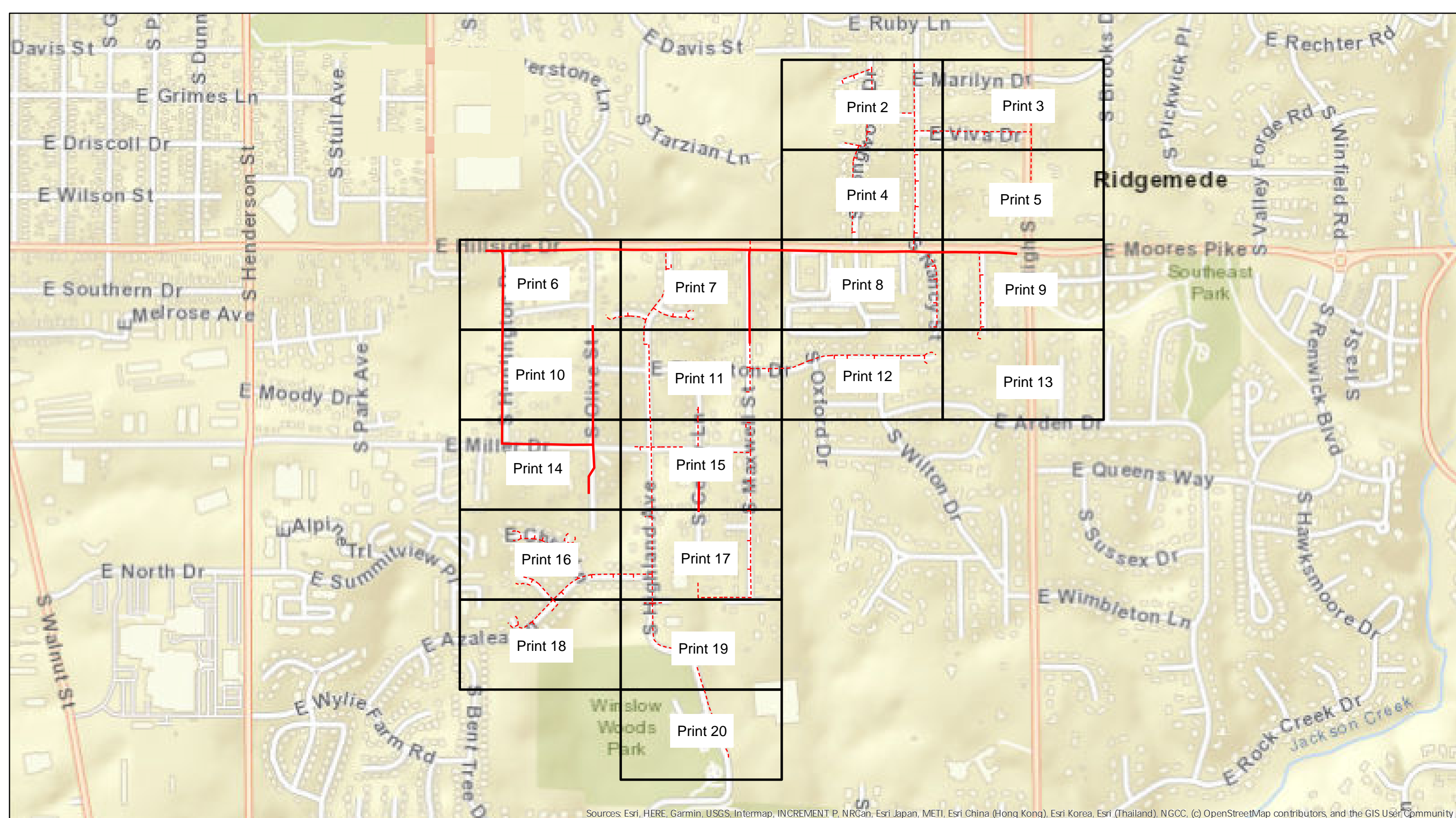

Sources: Esri, HERE, Garmin, USGS, Intermap, INCREMENT P, NRCan, Esri Japan, METI, Esri China (Hong Kong), Esri Korea, Esri (Thailand), NGCC, (c) OpenStreetMap contributors, and the GIS User Community



Legend BLC02a-F14_S Maxwell St

- Overhead Strand
- ⋯ Conduit
- Grids

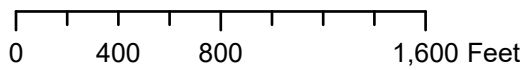

City of Bloomington, IN Permit:
Design View

INI	BY	DATE	DESCRIPTION



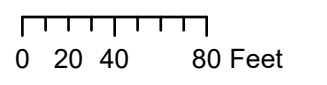
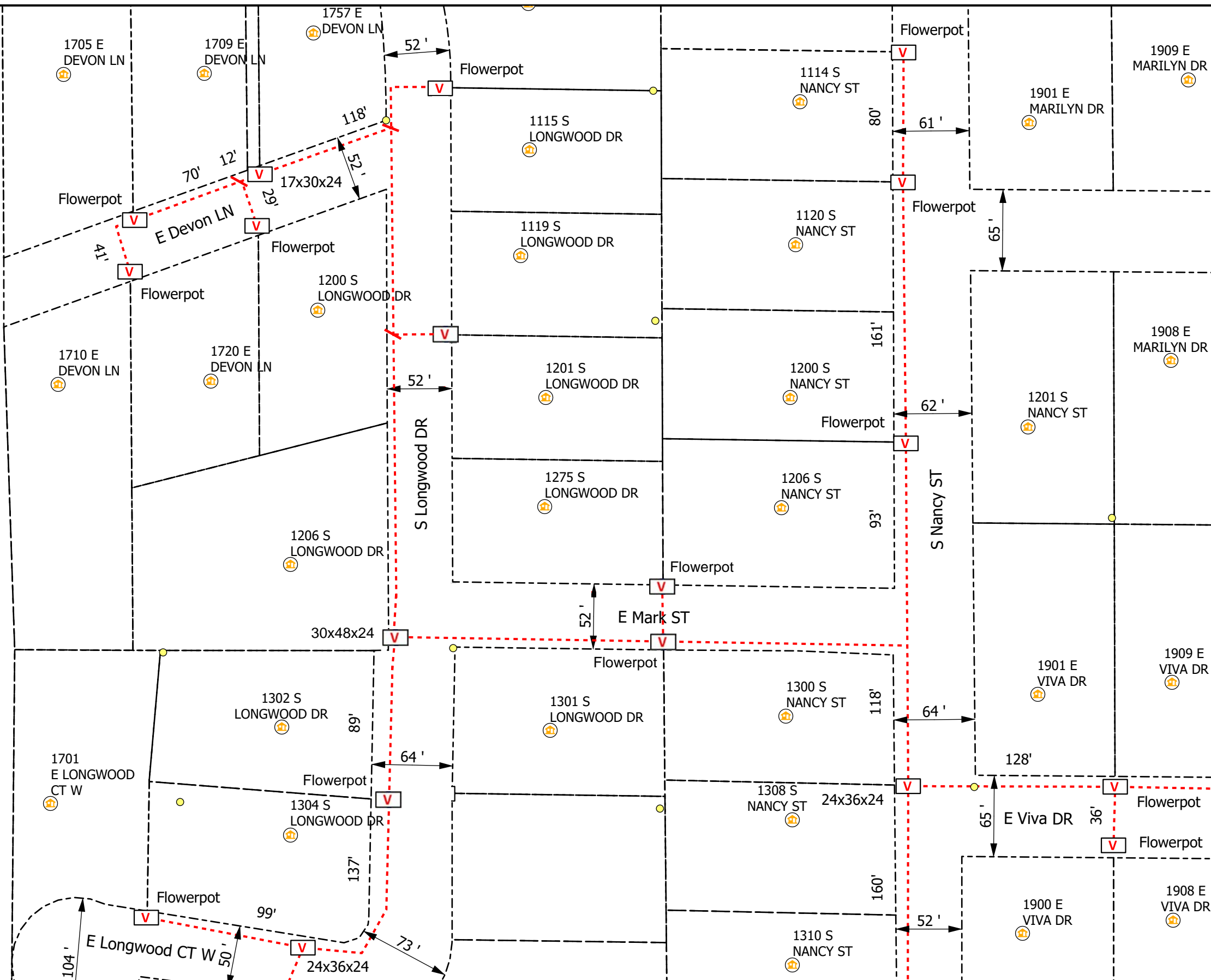

Legend

- Poles
- V Vaults
- Overhead Strand
- Conduit
- Bloomington_Parcels
- R Risers
- ⊙ Address
- Y Anchor
- ← Sidewalk
- Grids

All Flowerpots 12" DIA



City of Bloomington, IN Permit:
Design View

INI	BY	DATE	DESCRIPTION



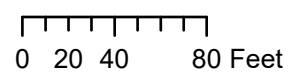
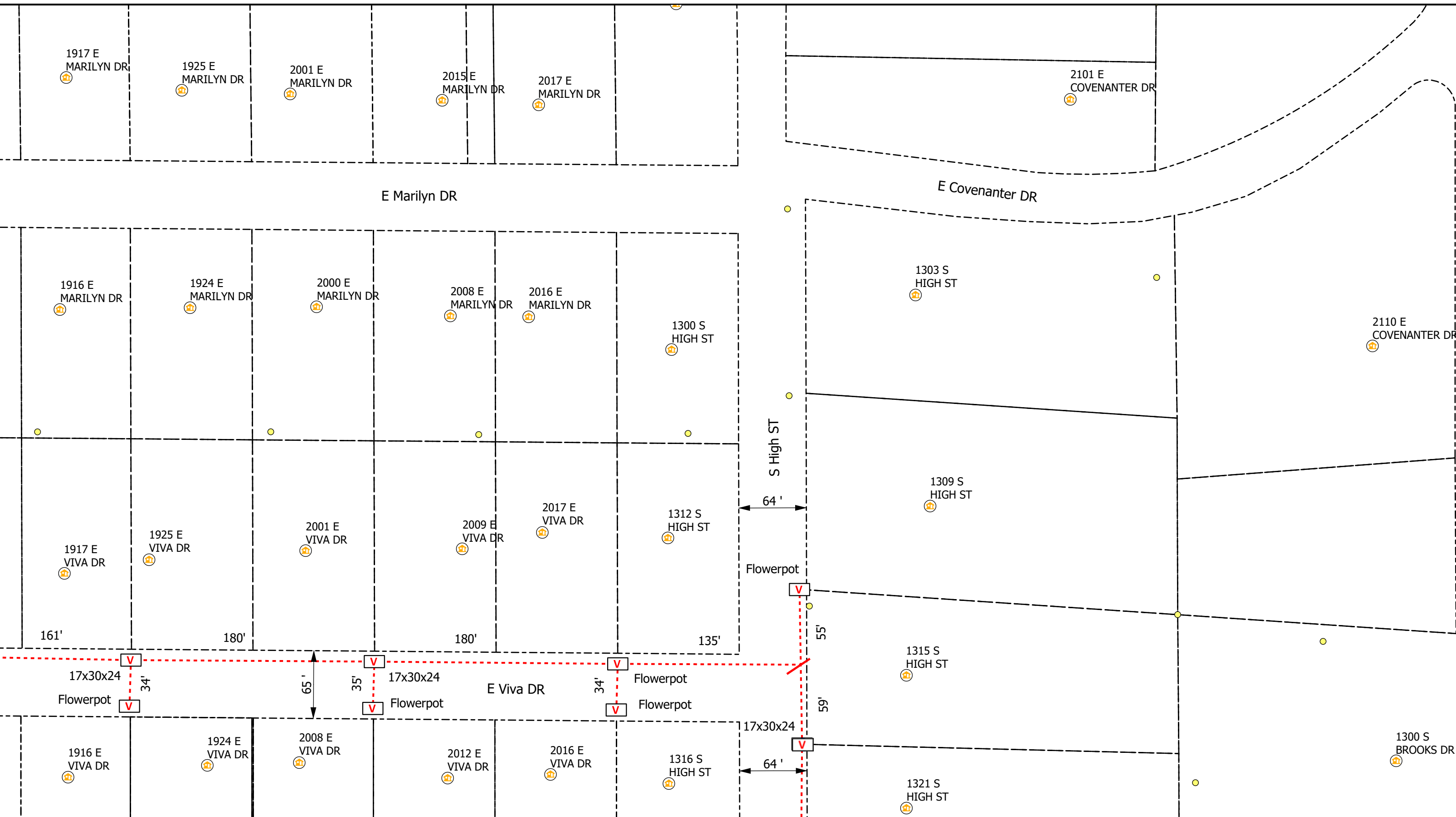

Legend

- Poles
- V Vaults
- Overhead Strand
- Conduit
- Bloomington_Parcels
- R Risers
- A Address
- Y Anchor
- ← Sidewalk
- Grids

All Flowerpots 12" DIA



City of Bloomington, IN Permit:
Design View

INI	BY	DATE	DESCRIPTION



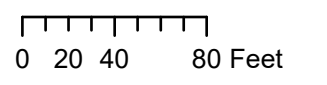
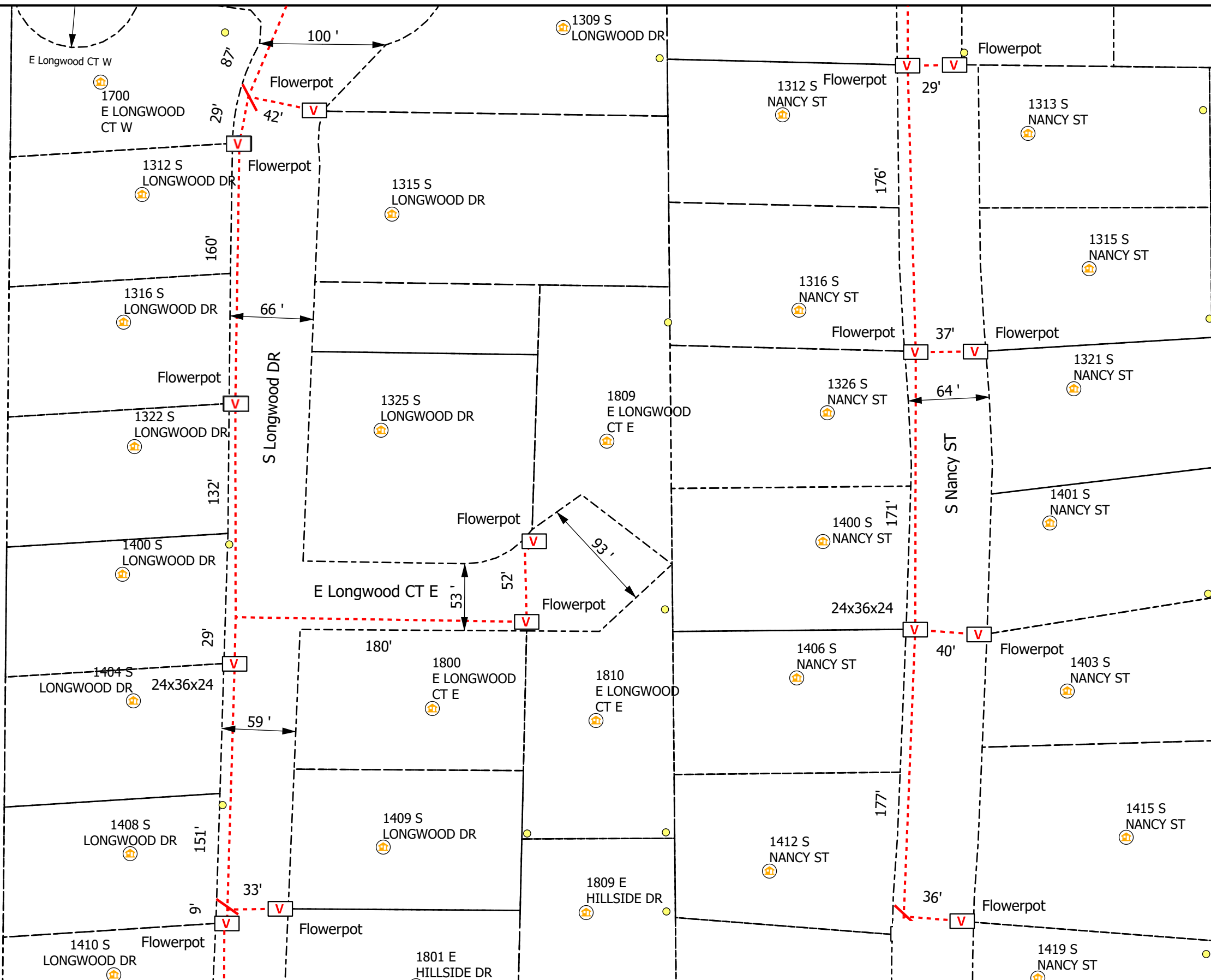

Legend

- Poles
- V Vaults
- Overhead Strand
- Conduit
- Bloomington_Parcels
- R Risers
- ⊙ Address
- Y Anchor
- ← Sidewalk
- Grids

All Flowerpots 12" DIA



City of Bloomington, IN Permit:
Design View

INI	BY	DATE	DESCRIPTION



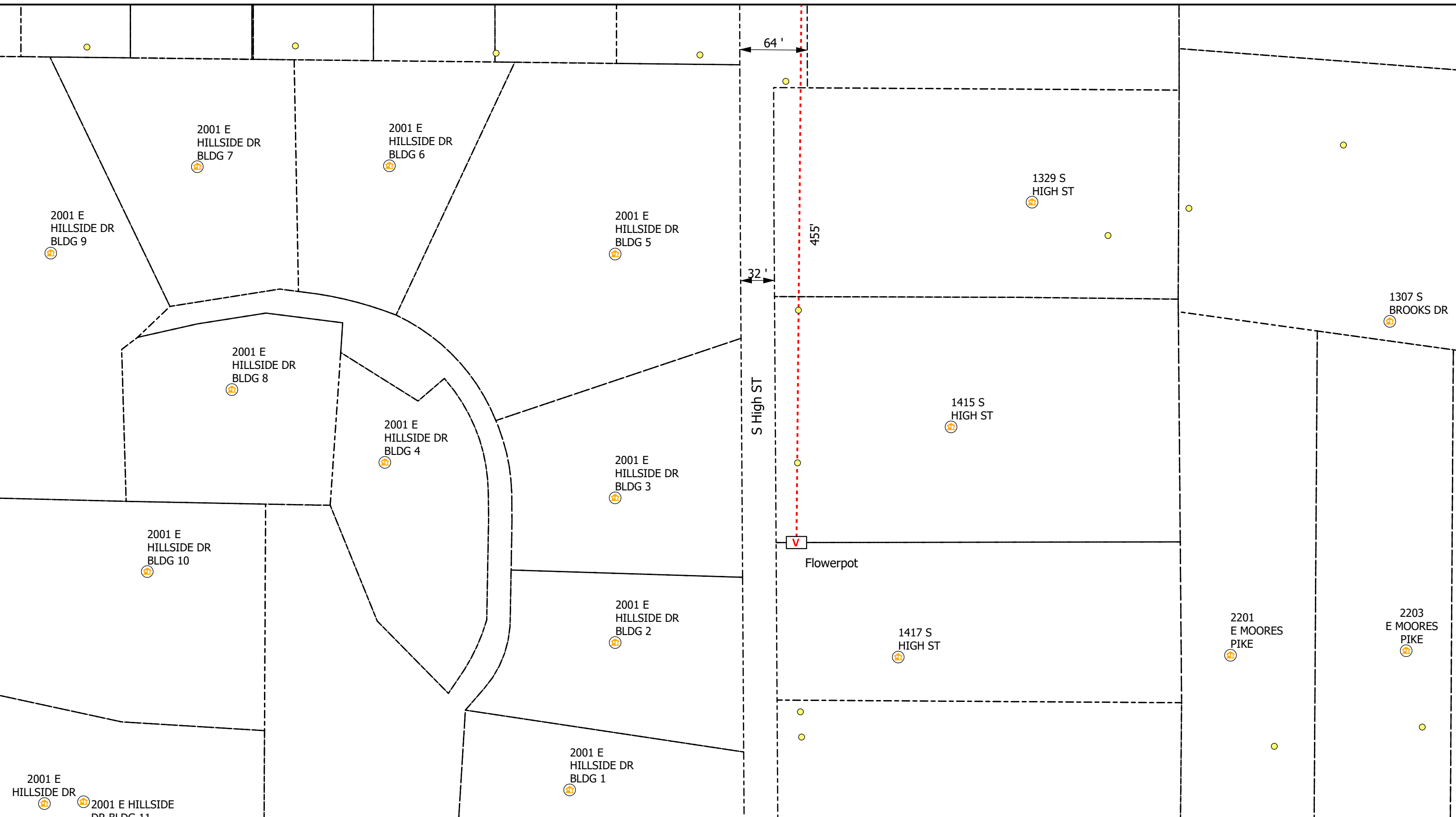

0 20 40 80 Feet

Legend

- Poles
- V Vaults
- Overhead Strand
- - - Conduit
- Bloomington_Parcels
- Ⓜ Risers
- Address
- Y Anchor
- ← Sidewalk
- Grids

All Flowerpots 12" DIA

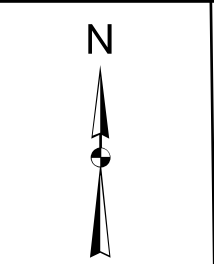

City of Bloomington, IN Permit:
Design View

INI	BY	DATE	DESCRIPTION

Print 5 of 20

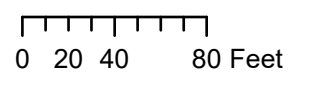
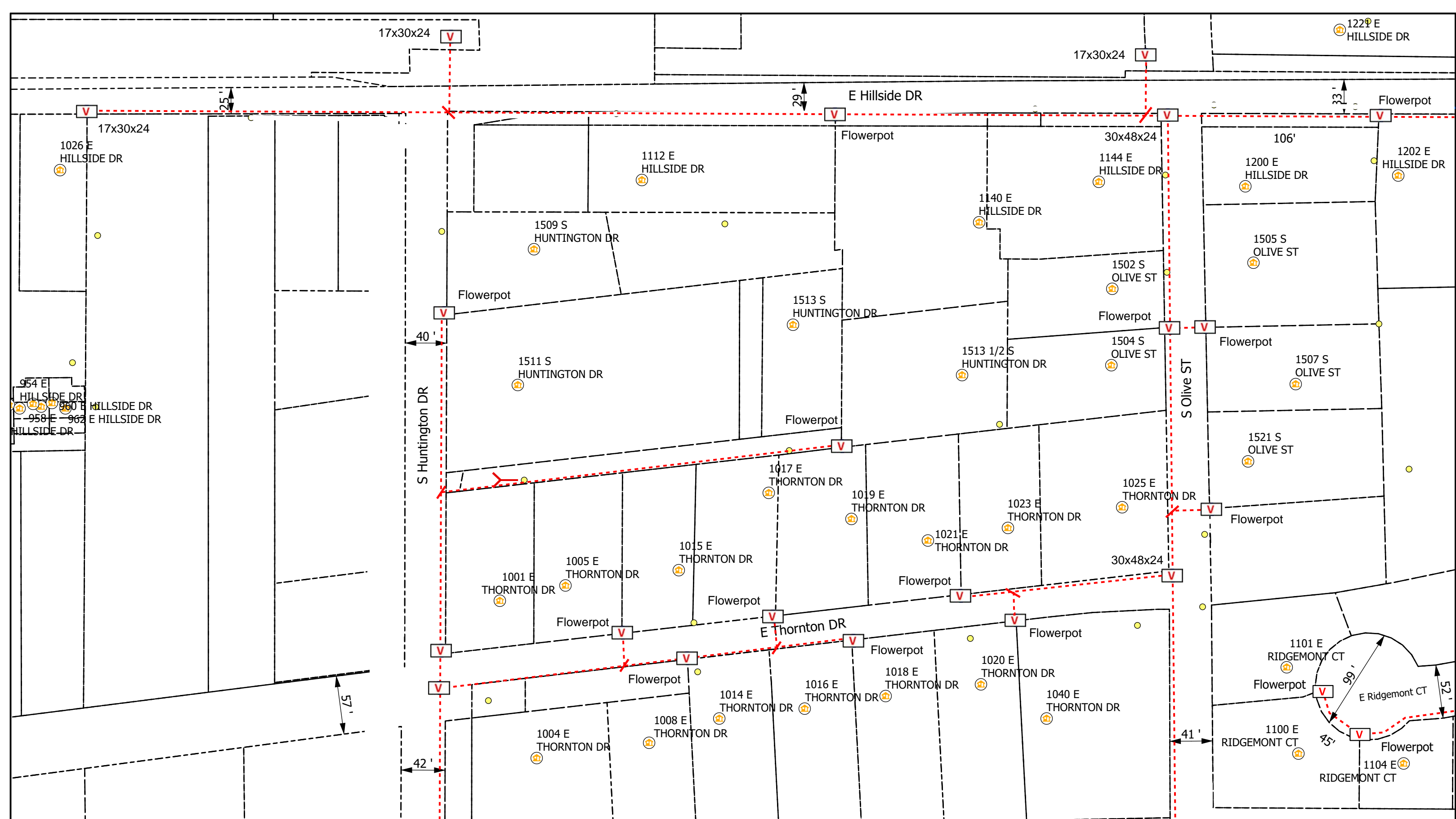

Legend

- Poles
- V Vaults
- Overhead Strand
- Conduit
- Bloomington_Parcels Bloomington_Parcels
- R Risers
- Address Address
- Y Anchor
- ← Sidewalk
- Grids Grids

All Flowerpots 12" DIA



City of Bloomington, IN Permit:
Design View

INI	BY	DATE	DESCRIPTION



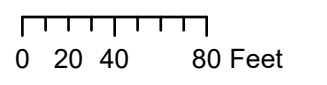
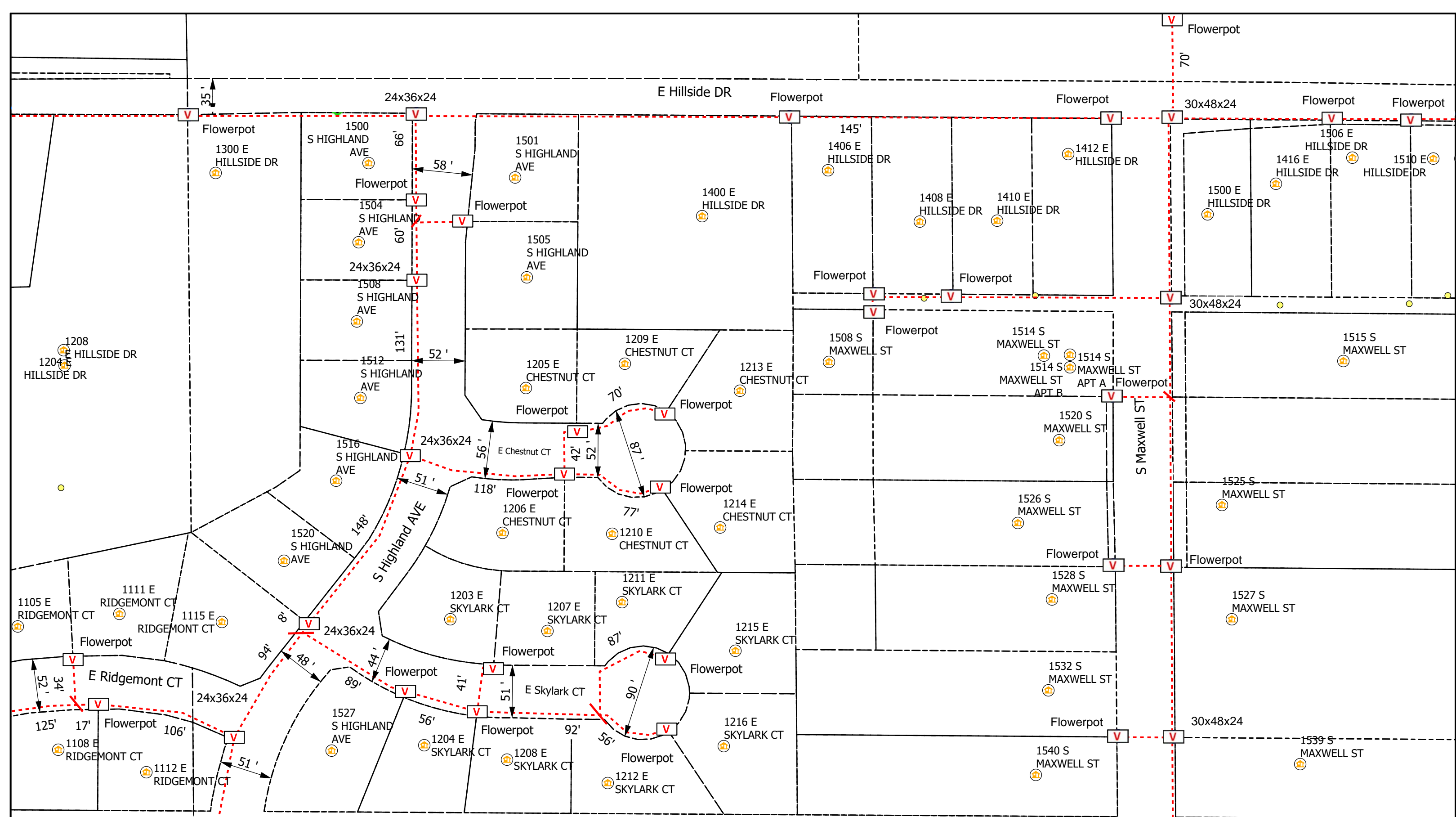

Legend

- Poles
- Vaults
- Overhead Strand
- Conduit
- Bloomington_Parcels
- Risers
- Address
- Anchor
- Sidewalk
- Grids

All Flowerpots 12" DIA



City of Bloomington, IN Permit:
Design View

INI	BY	DATE	DESCRIPTION



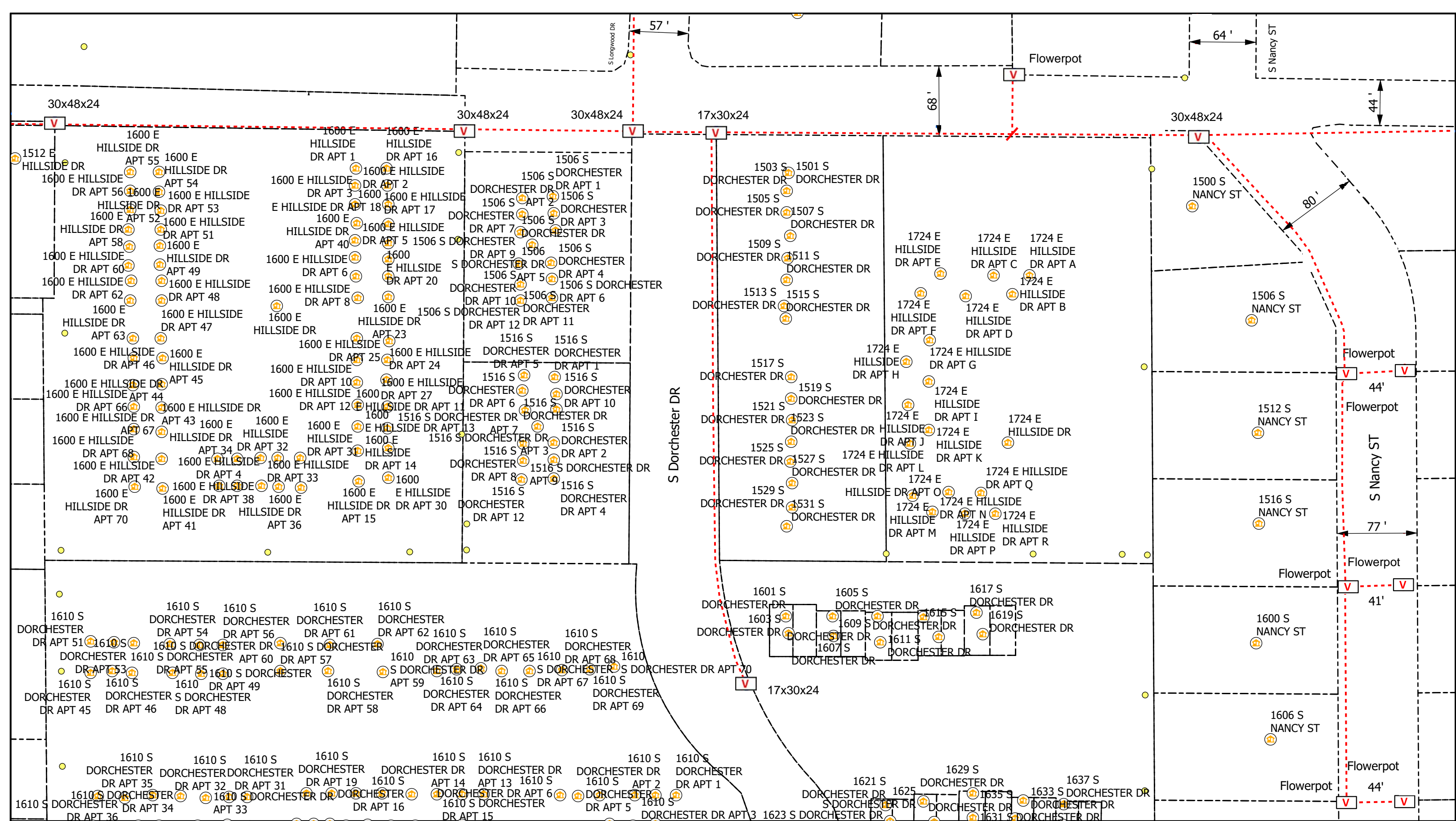

0 20 40 80 Feet

Legend

- Poles
- V Vaults
- Overhead Strand
- Conduit
- Bloomington_Parcels
- R Risers
- ⊙ Address
- Y Anchor
- ↖ Sidewalk
- Grids

All Flowerpots 12" DIA

N



City of Bloomington, IN Permit:
Design View

INI	BY	DATE	DESCRIPTION



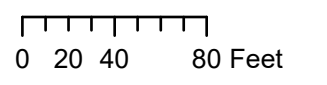
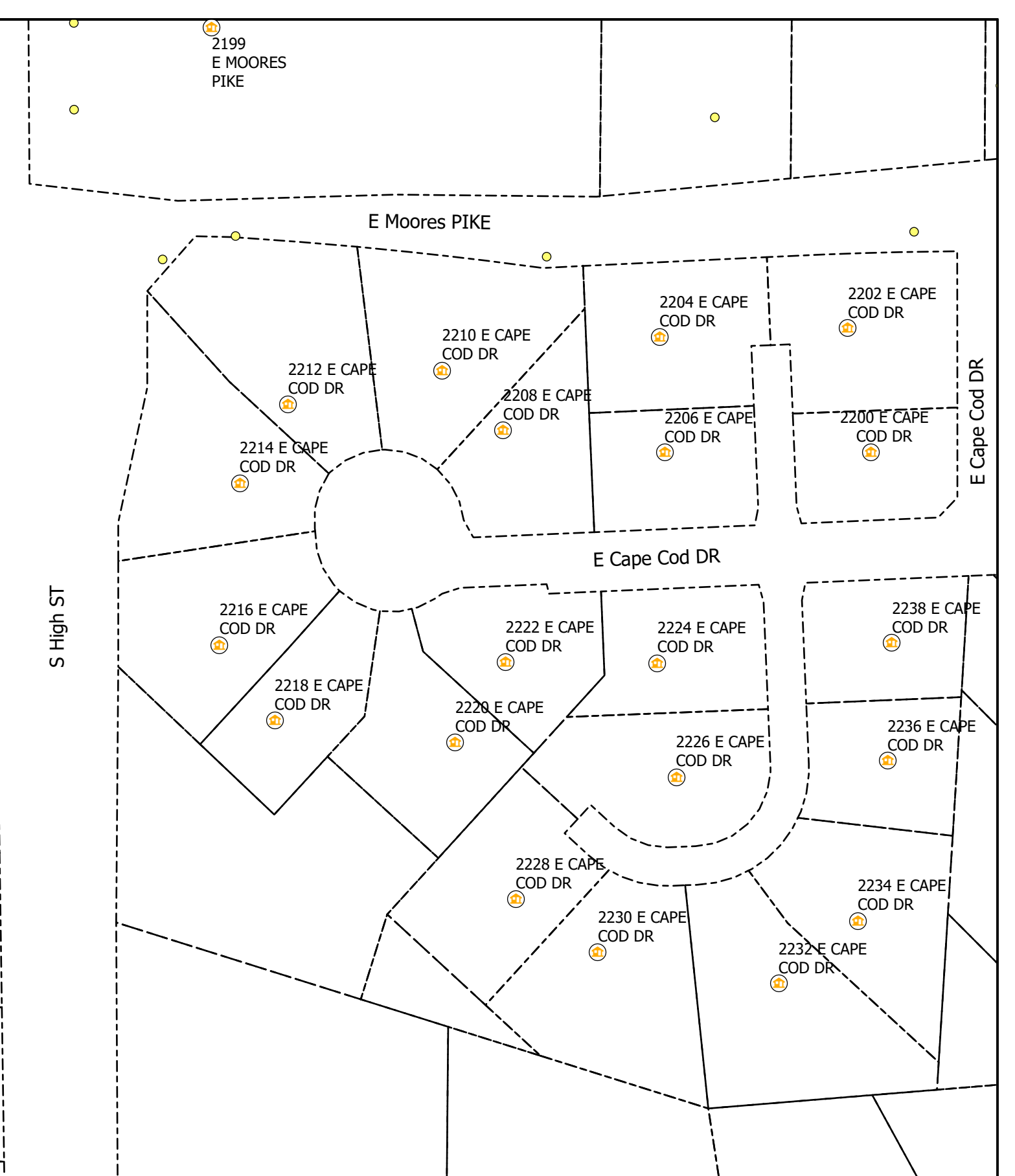
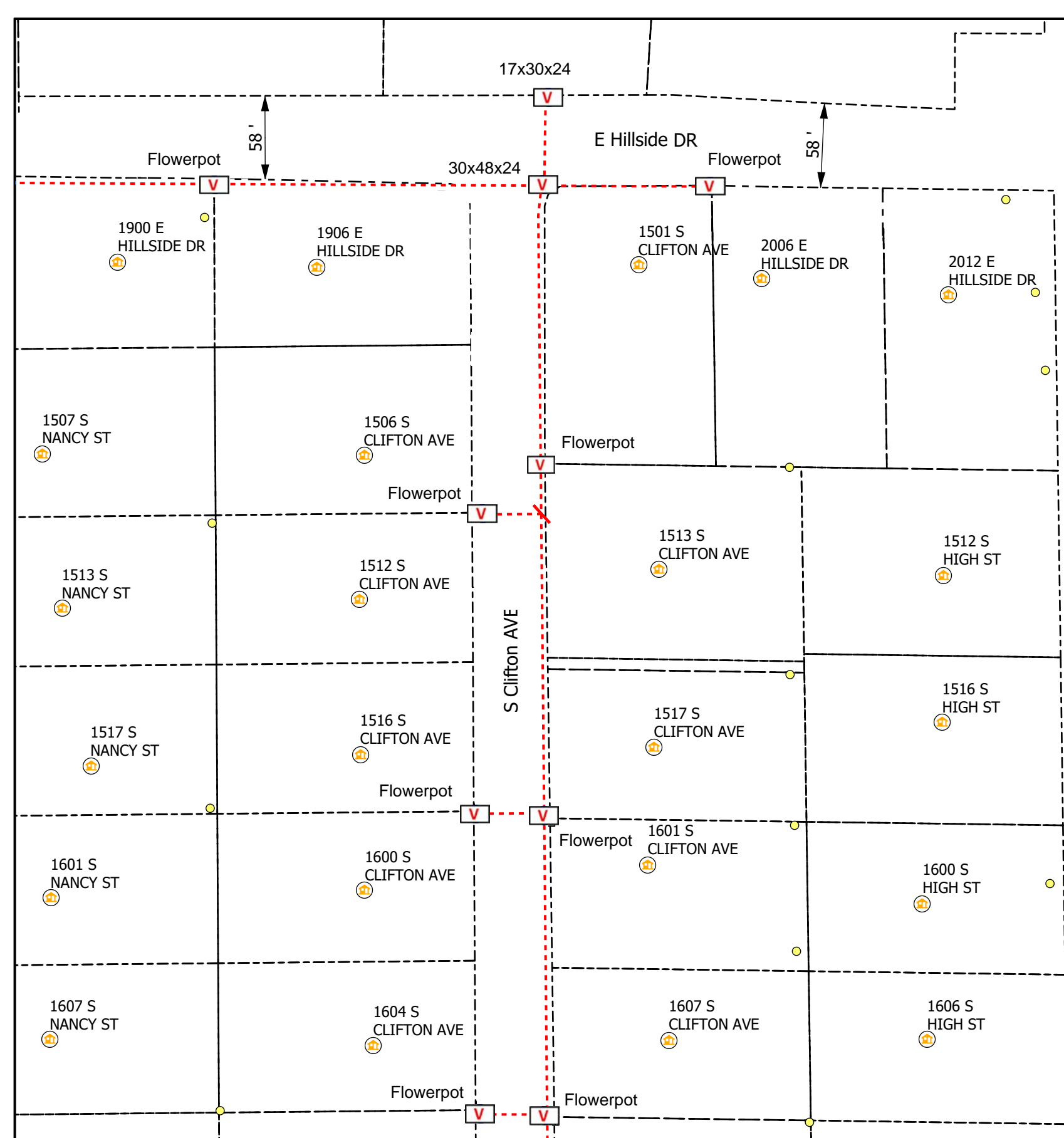

Legend

- Poles
- V Vaults
- Overhead Strand
- Conduit
- Bloomington_Parcels
- Risers
- Address
- Anchor
- Sidewalk
- Grids

All Flowerpots 12" DIA



City of Bloomington, IN Permit:
Design View

INI	BY	DATE	DESCRIPTION



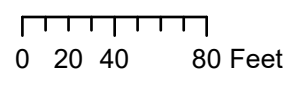
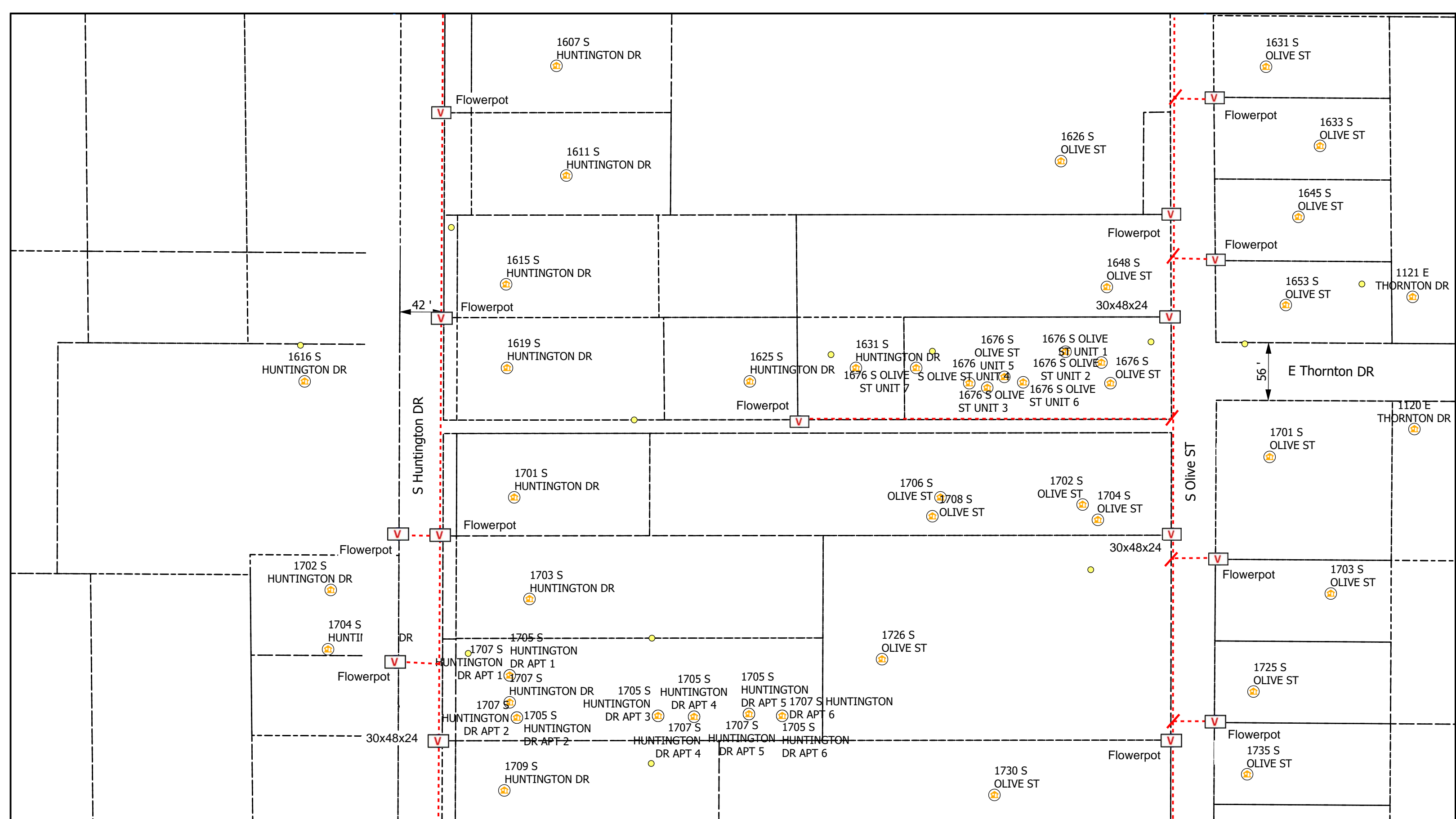

Legend

- Poles
- V Vaults
- Overhead Strand
- Conduit
- Bloomington_Parcels
- R Risers
- A Address
- Y Anchor
- ← Sidewalk
- Grids

All Flowerpots 12" DIA



City of Bloomington, IN Permit:
Design View

INI	BY	DATE	DESCRIPTION



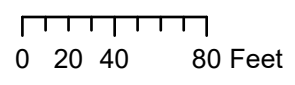
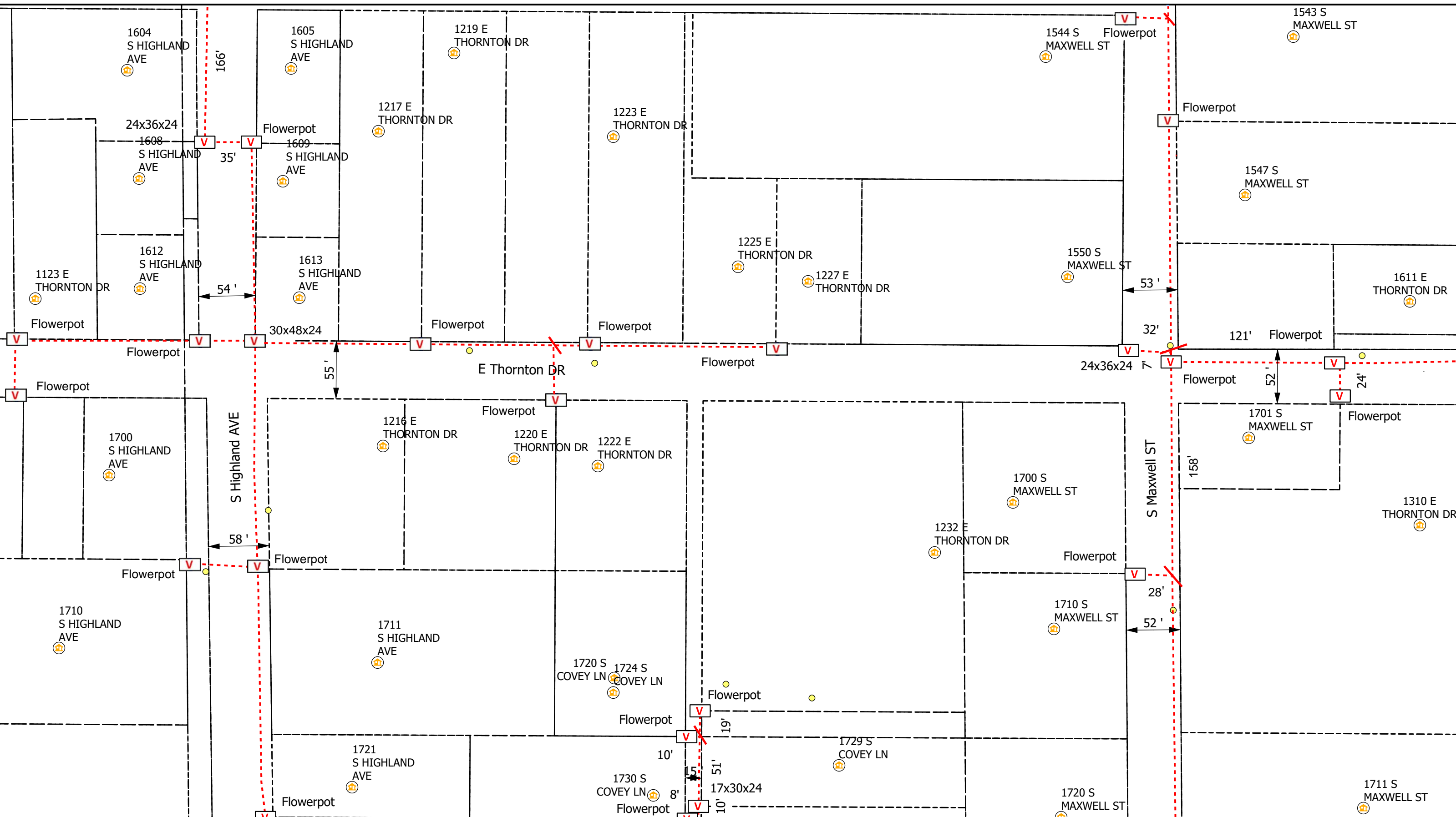

Legend

- Poles
- V Vaults
- Overhead Strand
- Conduit
- Bloomington_Parcels
- R Risers
- A Address
- Y Anchor
- ← Sidewalk
- Grids

All Flowerpots 12" DIA



City of Bloomington, IN Permit:
Design View

INI	BY	DATE	DESCRIPTION



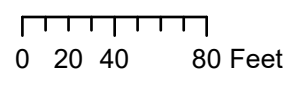
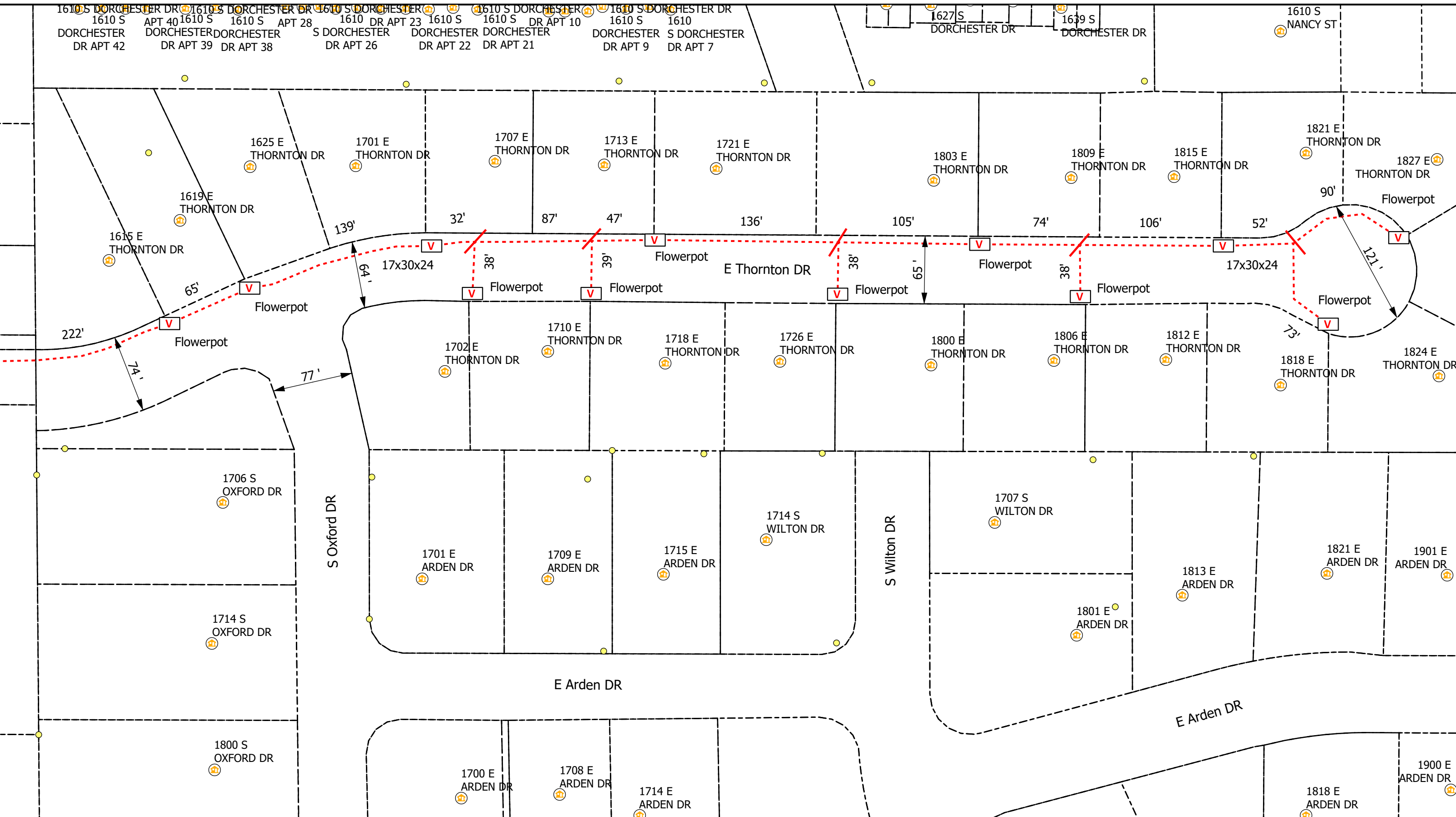

Legend

- Poles
- V Vaults
- Overhead Strand
- Conduit
- Bloomington_Parcels
- R Risers
- ⊕ Address
- Y Anchor
- ← Sidewalk
- Grids

All Flowerpots 12" DIA



City of Bloomington, IN Permit:
Design View

INI	BY	DATE	DESCRIPTION



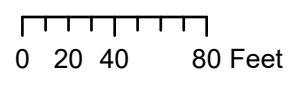
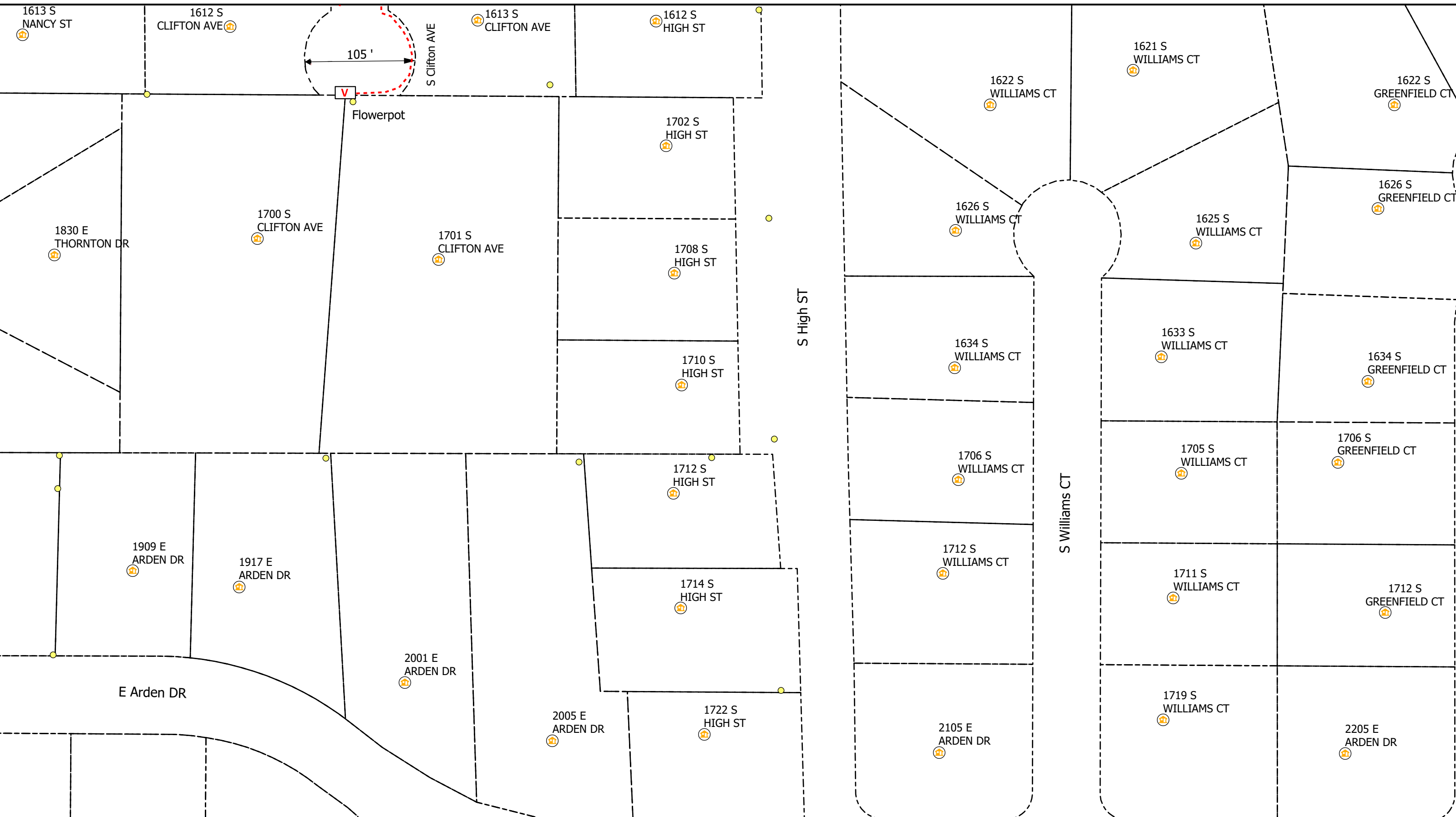

Legend

- Poles
- Vaults
- Overhead Strand
- Conduit
- Bloomington_Parcels
- Risers
- Address
- Anchor
- Sidewalk
- Grids

All Flowerpots 12" DIA



City of Bloomington, IN Permit:
Design View

INI	BY	DATE	DESCRIPTION



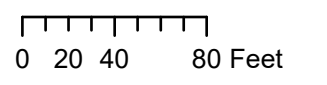
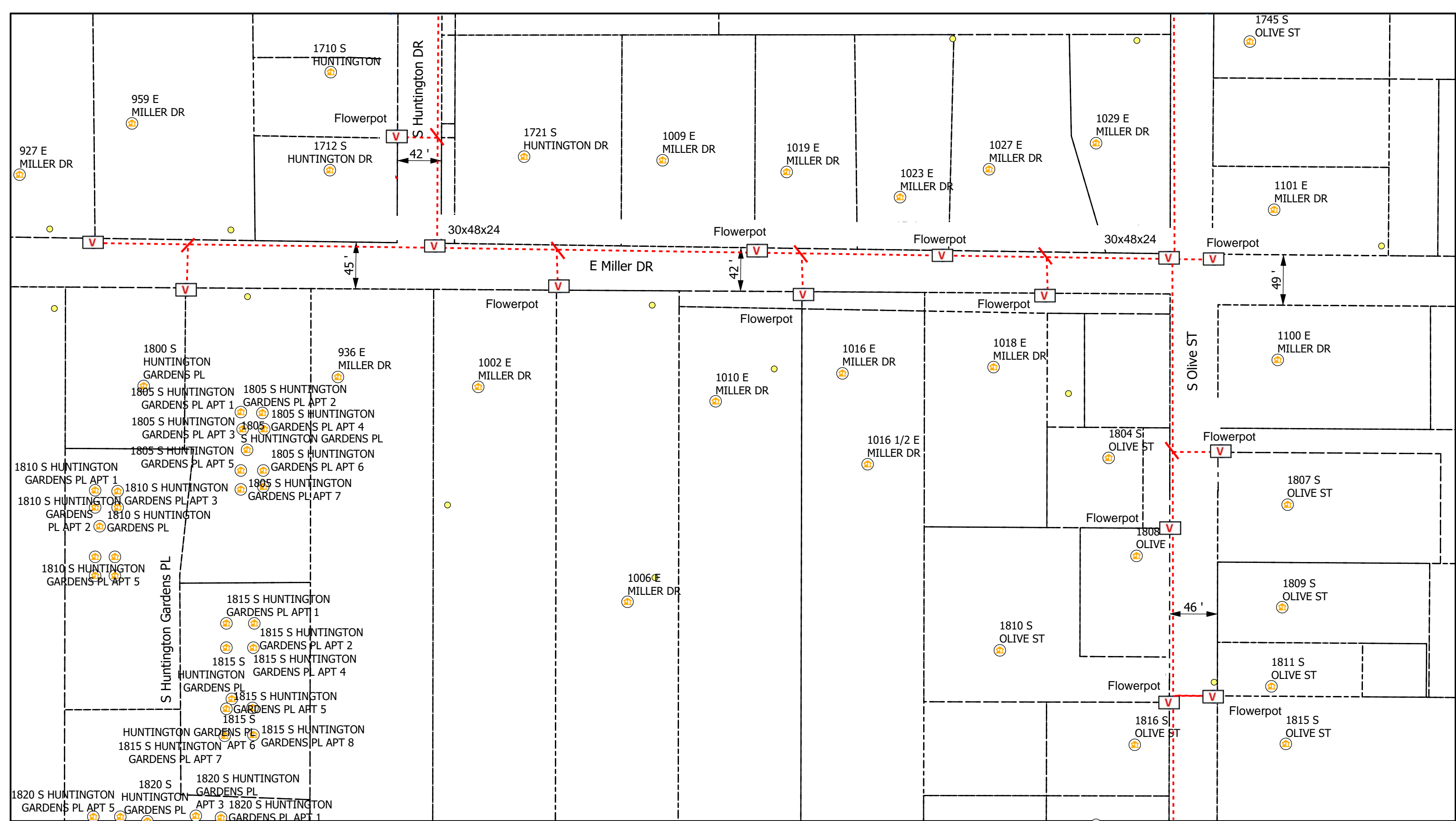

Legend

- Poles
- Risers
- Address
- Grids
- Anchors
- Sidewalk
- Vaults
- Bloomington_Parcels
- Overhead Strand
- Conduit

All Flowerpots 12" DIA



City of Bloomington, IN Permit:
Design View

INI	BY	DATE	DESCRIPTION



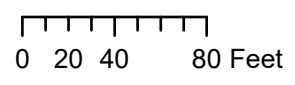
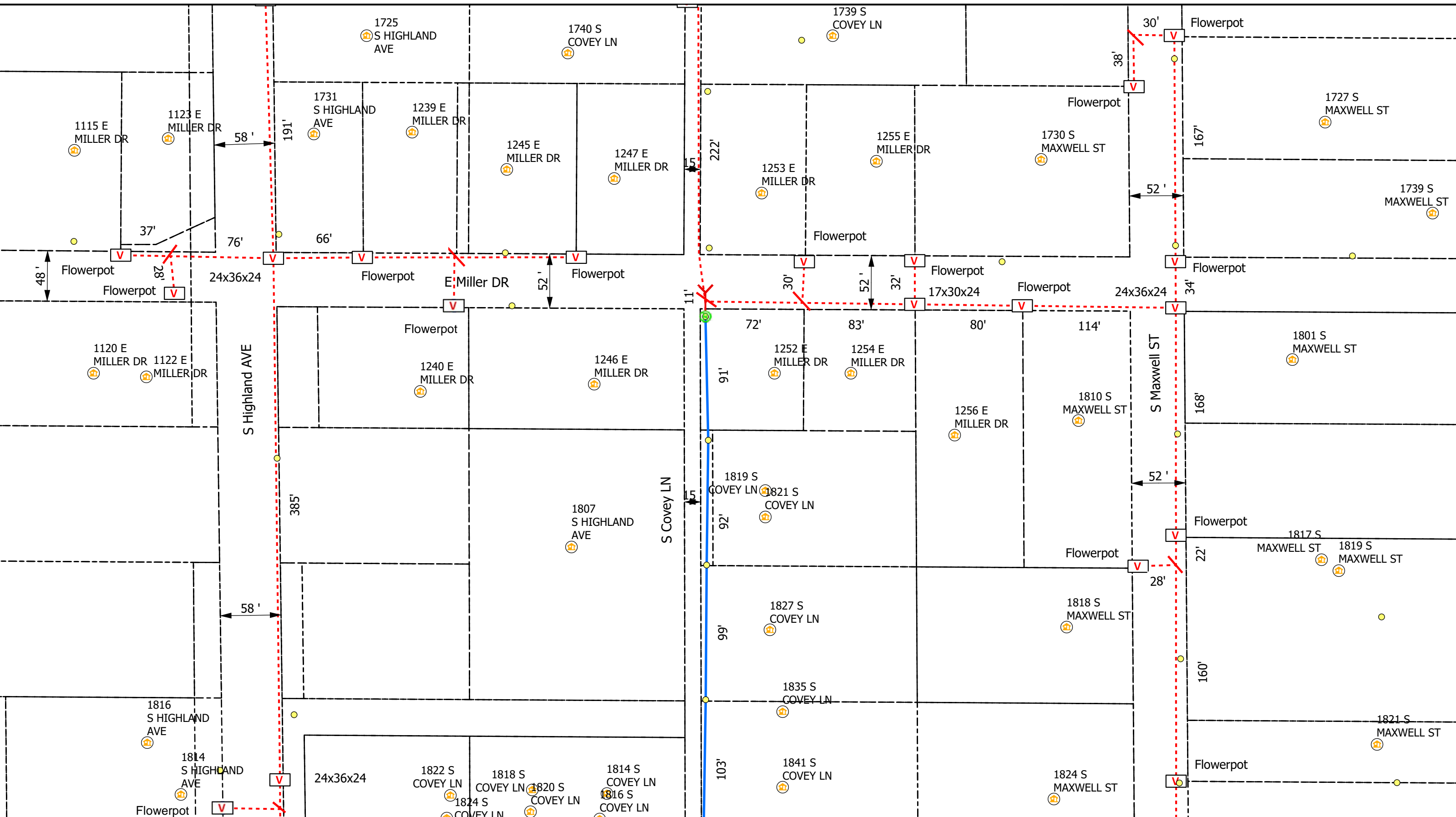

Legend

- Poles
- Vaults
- Overhead Strand
- Conduit
- Bloomington_Parcels
- Risers
- Address
- Anchor
- Sidewalk
- Grids

All Flowerpots 12" DIA



City of Bloomington, IN Permit:
Design View

INI	BY	DATE	DESCRIPTION



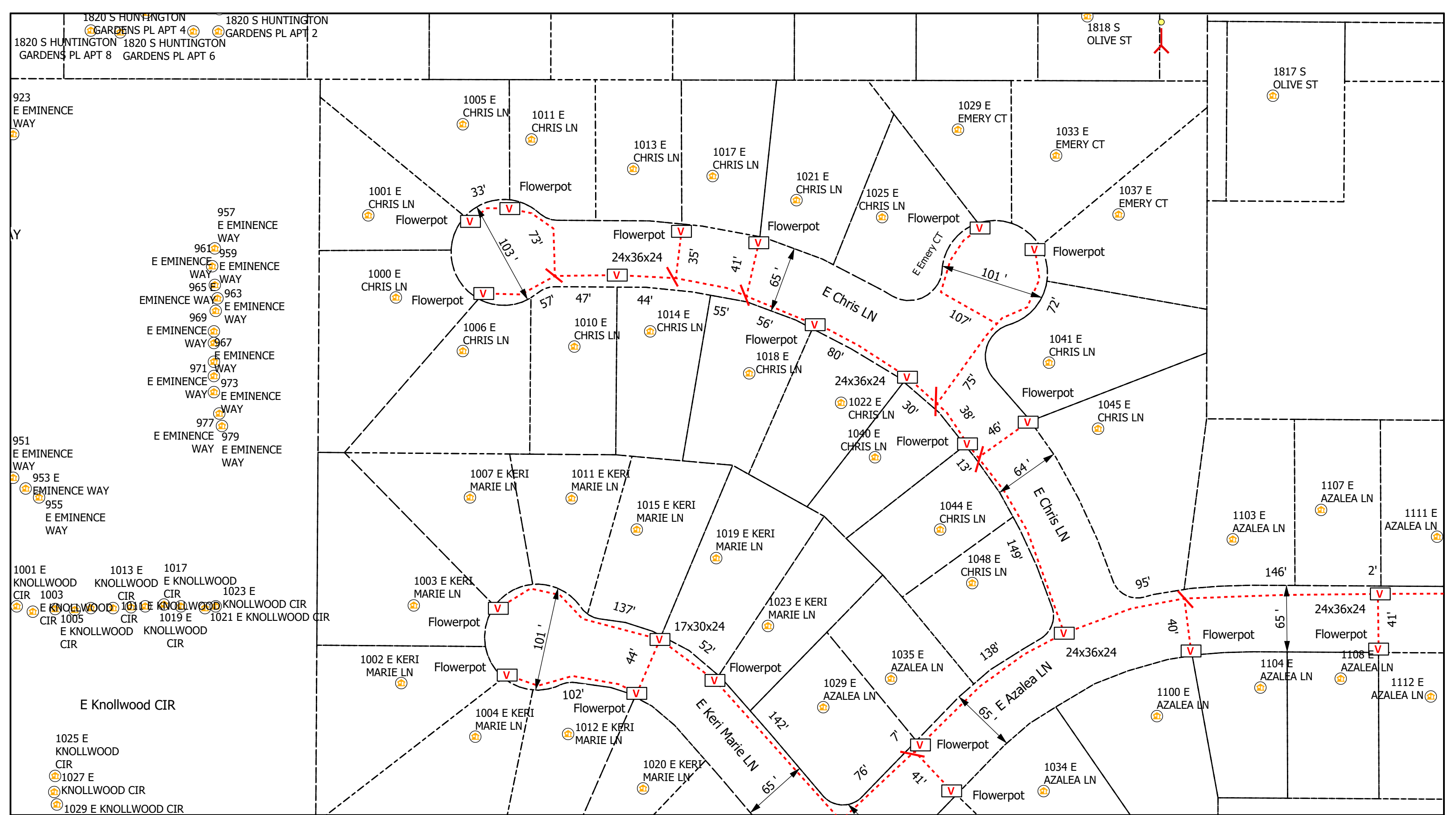

0 20 40 80 Feet

Legend

- Poles
- Vaults
- Overhead Strand
- Conduit
- Bloomington_Parcels
- Risers
- Address
- Anchor
- Sidewalk
- Grids

All Flowerpots 12" DIA

N



City of Bloomington, IN Permit:
Design View

INI	BY	DATE	DESCRIPTION



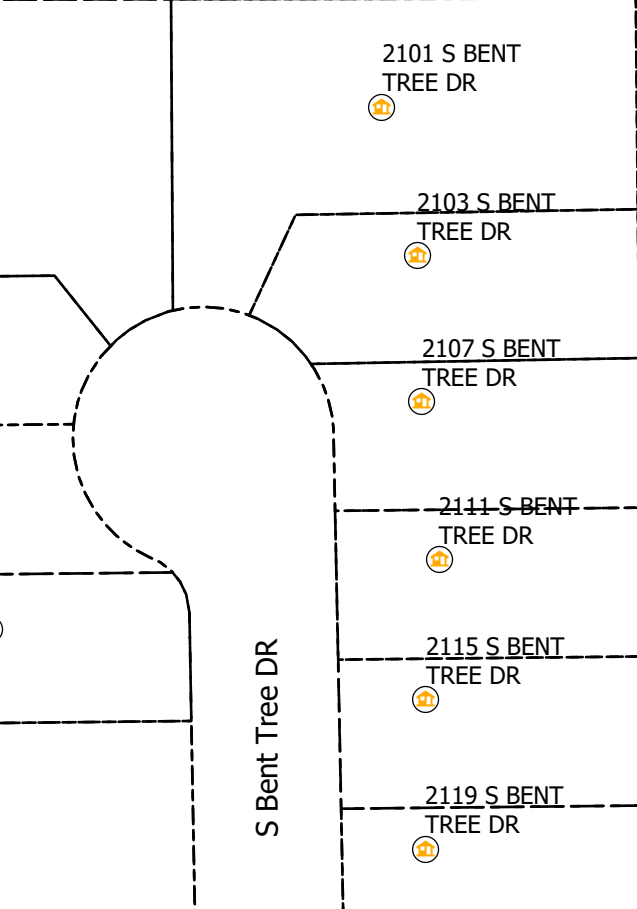
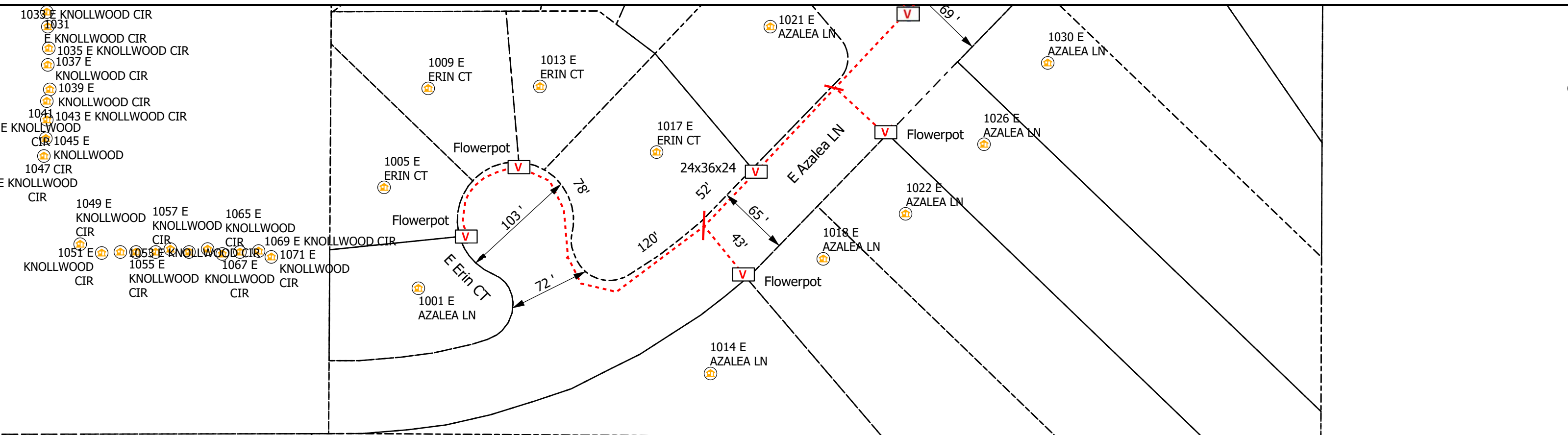

Legend

- Poles
- V Vaults
- Overhead Strand
- Conduit
- Bloomington_Parcels
- R Risers
- A Address
- Y Anchor
- ← Sidewalk
- Grids

All Flowerpots 12" DIA



City of Bloomington, IN Permit:
Design View

INI	BY	DATE	DESCRIPTION



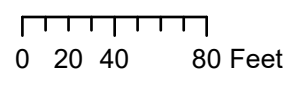
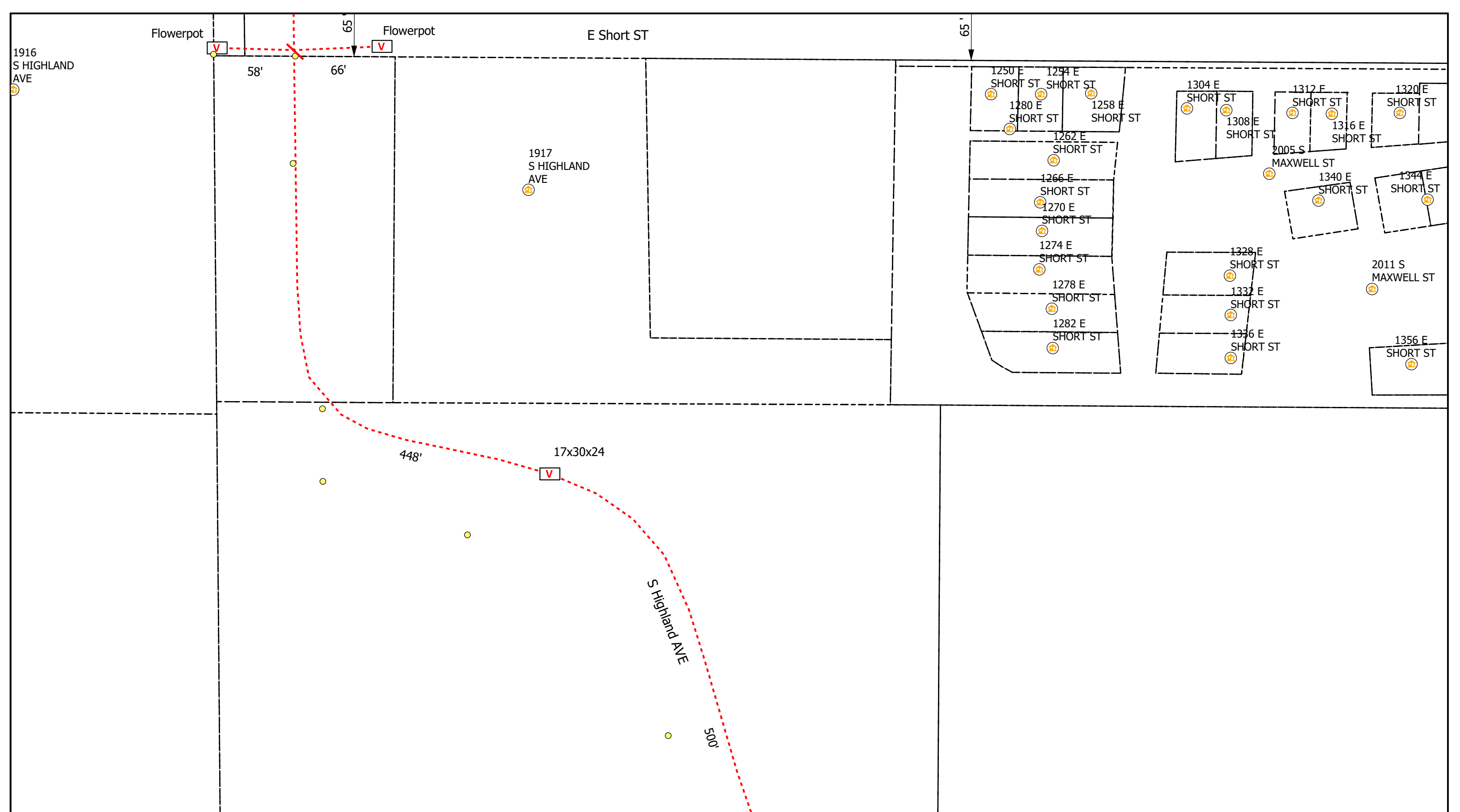

Legend

- Poles
- Vaults
- Overhead Strand
- Conduit
- Bloomington_Parcels
- R Risers
- A Address
- Anchor
- Sidewalk
- Grids

All Flowerpots 12" DIA



City of Bloomington, IN Permit:
Design View

INI	BY	DATE	DESCRIPTION



2125
S HIGHLAND
AVE

2120
S HIGHLAND
AVE

 Flowerpot

S Highland AVE

 17x30x24











54'

307'



0 20 40 80 Feet

Legend

-  Poles
-  Bloomington_Parcels
-  Anchor
-  Vaults
-  Risers
-  Sidewalk
-  Overhead Strand
-  Address
-  Conduit
-  Grids

All Flowerpots 12" DIA



City of Bloomington, IN Permit:
Design View

INI	BY	DATE	DESCRIPTION



Carlton® PV-Mold® Nonmetallic Pole Riser System

Carlton PV-Mold is a nonmetallic pole riser system designed to protect communications power cable installed on poles.

Features:

- Meets or exceeds requirements outlined in the National Electric Safety Code (NESC).
- Designed in accordance with NEMA TC-19 specifications.
- Ultraviolet, cold temperature and corrosive atmosphere resistant.
- Schedule 40 wall meets Schedule 80 PVC conduit impact requirements per NEMA TC-19.
- No grounding required.
- Belled end fits over each added section or conduit.
- Flame retardant.
- Requires no maintenance.
- PV-Mold acts as an insulator against electrical shock.
- Interchangeable parts and accessories to match the needs of specific requirements.



Steel U-Guard requires grounding strapping and does not have belled ends.



PV-Mold has belled ends, flanged design and does not require grounding.

Flanged Overall Length 10 Feet, Including Bell

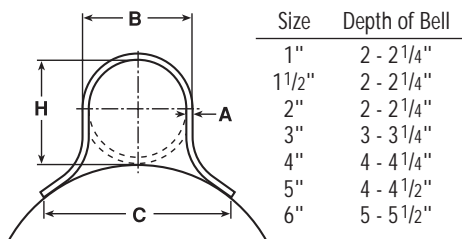

Slots are 1/2" from side to side, and allow for expansion and contraction.

Slot Dimensions: for sizes 2" through 6" are 5/16" wide, 3/4" long.

Slot Dimensions: for 1" and 1 1/2" are 3/16" wide, 3/4" long.

Slot Spacing: 18" from center, beginning 6" from end.

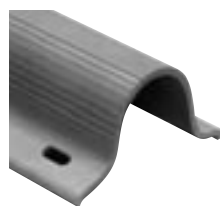

Standard Duty

Part No.	Size	Std. Ctn. Qty.	Std. Ctn. Wt. (lbs.)	Dimensions				Actual Impact @ 0°C 20 Pound Tup
				A	B	C	H	
59208N	1"	294	1059	0.100"	1 5/8"	2 3/8"	1 5/8"	40 Ft.-Lbs.
59211N	2"	136	726	0.100"	2 3/8"	4 1/2"	2 3/8"	100 Ft.-Lbs.
59211X (5' length)	2"	136	363	0.100"	2 3/8"	4 1/2"	2 3/8"	100 Ft.-Lbs.
59213N	3"	66	761	0.150"	3 1/2"	6"	3 1/2"	110 Ft.-Lbs.
59213X (5' length)	3"	66	381	0.150"	3 1/2"	6"	3 1/2"	100 Ft.-Lbs.
59215N	4"	65	910	0.150"	4 1/2"	6 1/2"	4 1/2"	110 Ft.-Lbs.
59216N	5"	30	515	0.150"	5 1/2"	7 1/2"	5 1/2"	110 Ft.-Lbs.

Heavy Duty Schedule 40

59010N	1 1/2"	200	1142	0.145"	1 29/32"	3 1/2"	1 29/32"	100 Ft.-Lbs.
59011N	2"	136	1214	0.154"	2 3/8"	4 1/2"	2 3/8"	150 Ft.-Lbs.
59013N	3"	66	937	0.216"	3 1/2"	6"	3 9/32"	150 Ft.-Lbs.
59015N	4"	65	1621	0.237"	4 1/2"	6 1/2"	4 1/2"	260 Ft.-Lbs.
59015X (5' length)	4"	65	707	0.237"	4 1/2"	6 1/2"	4 1/2"	260 Ft.-Lbs.
59016N	5"	30	870	0.258"	5 1/2"	7 1/2"	5 1/2"	260 Ft.-Lbs.
59017N	6"	30	1160	0.280"	6 5/8"	8 3/4"	6 5/8"	260 Ft.-Lbs.

Extra Heavy Duty Schedule 80

59411N	2"	136	1549	0.218"	2 3/8"	4 1/2"	2 3/8"	300 Ft.-Lbs.
59413N	3"	66	1495	0.030"	3 1/2"	6"	3 1/2"	525 Ft.-Lbs.

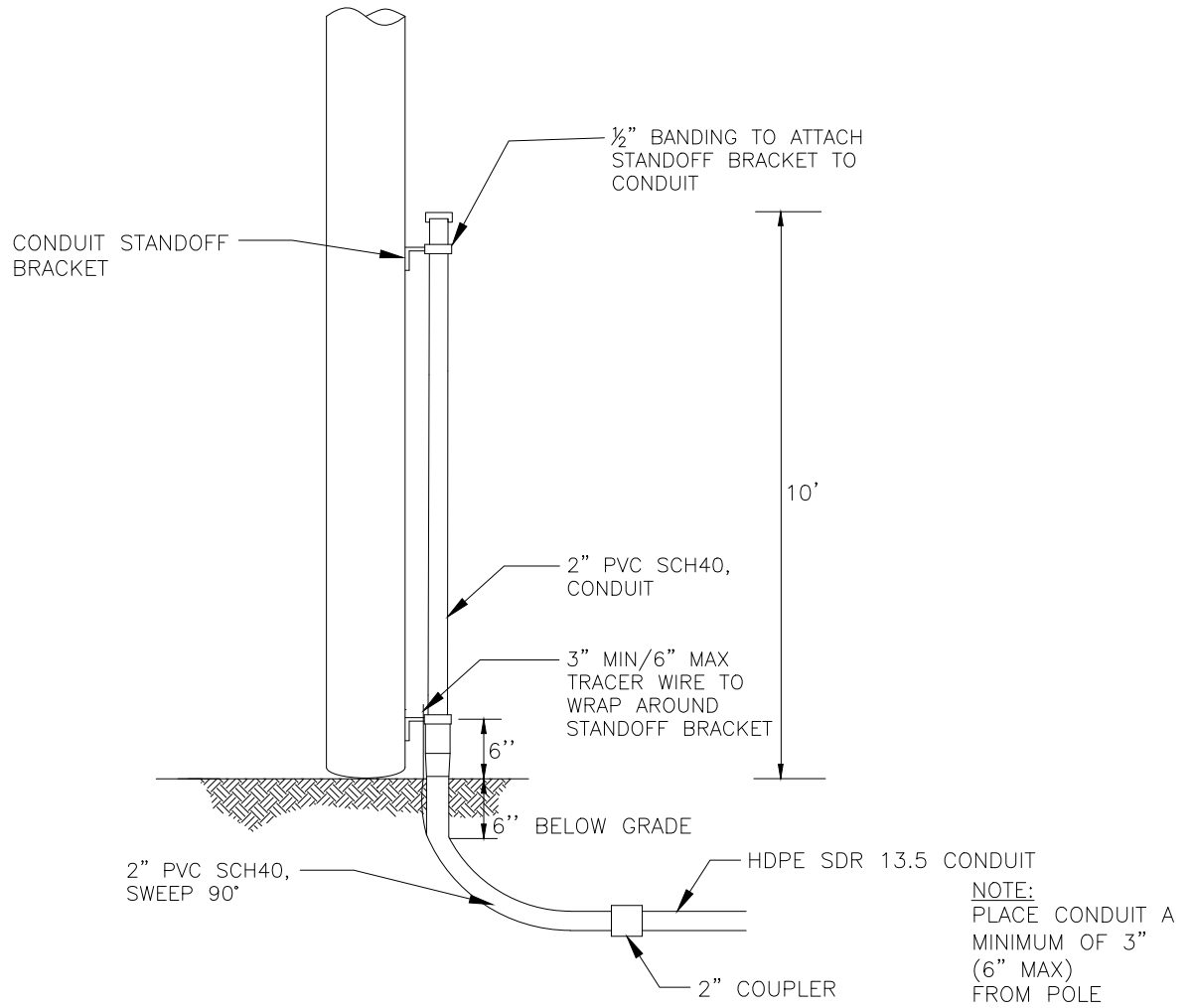

DESCRIPTION	QTY	MANUFACTURER (PREFERRED)	PART #
SCREW, LAG, 1/2" x 4-1/2"	10		
HDPE SDR 13.5 CONDUIT, VARIOUS SIZES	N/A		
2" PVC SCH40, RISER PIPE	1		
#12 TRACER WIRE	N/A		
2" PVC SCH40, SWEEP, 90 DEG	1		
CONDUIT STANDOFF BRACKET	VARIES		
CONDUIT STRAP KIT	VARIES		
2" COUPLER	1		



TYPICAL RISER
CONDUIT
WOOD POLE

(R2-W)

CONCEPTUAL SIDE VIEW

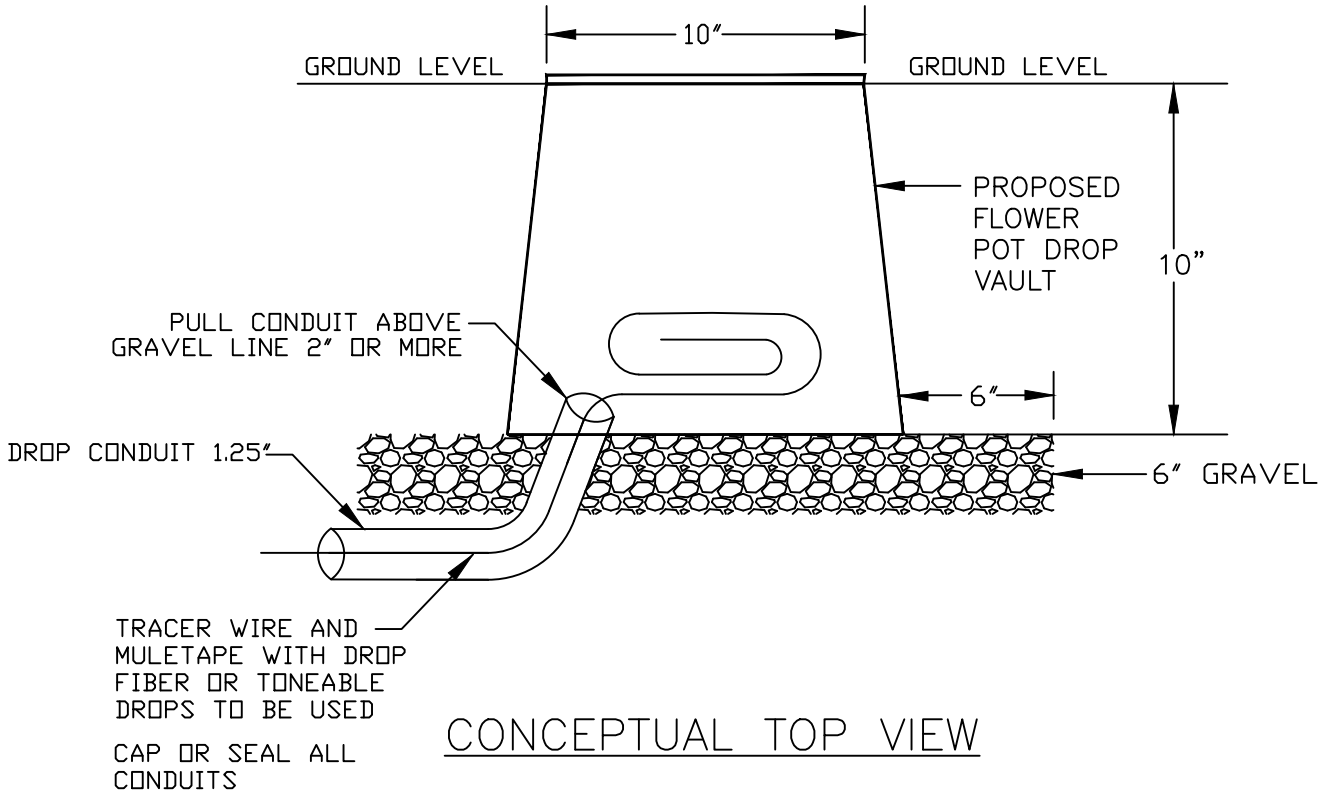

CONCEPTUAL TOP VIEW

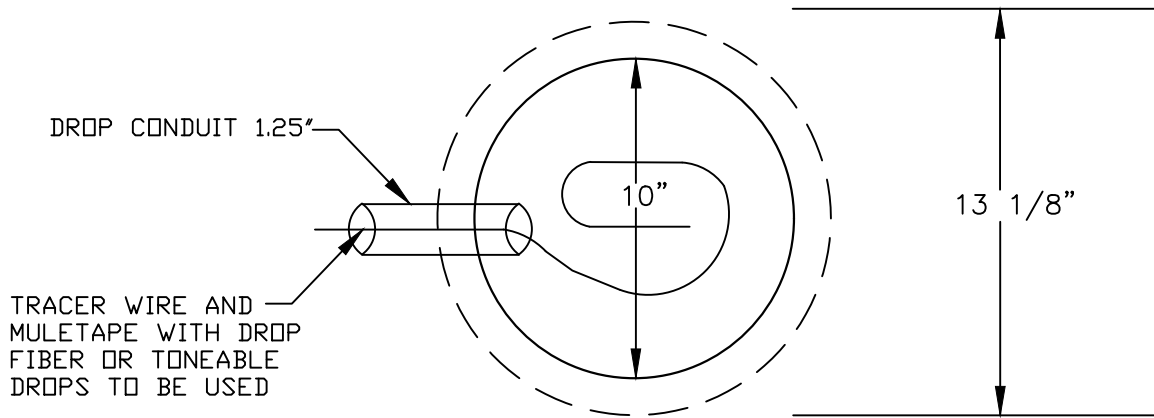

FLOWER POT

30"x48" PC UNIT, 2PC TIER 15/22
 18", 24", and 36" HEIGHT



AMERICAN POLYMER COMPANY

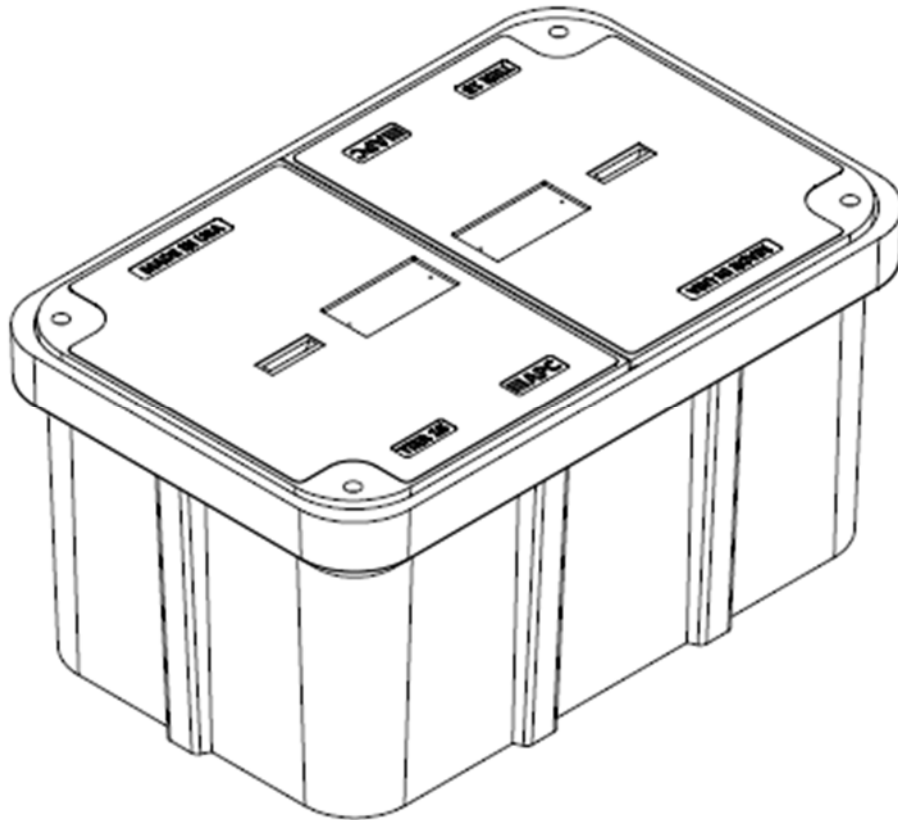

Description	Nominal Size	ANSI Tier	Part Number	Estimated Weight
PC Unit – TIER 15	30"x48"x18"	Tier 15	P304818HU15...	460 lbs.
PC Unit – TIER 22	30"x48"x18"	Tier 22	P304818HU22...	525 lbs.
PC Unit – TIER 15	30"x48"x24"	Tier 15	P304824HU15...	510 lbs.
PC Unit – TIER 22	30"x48"x24"	Tier 22	P304824HU22...	575 lbs.
PC Unit – TIER 15	30"x48"x36"	Tier 15	P304836HU15...	615 lbs.
PC Unit – TIER 22	30"x48"x36"	Tier 22	P304836HU22...	680 lbs.



30"x48" PC UNIT, 2PC TIER 15/22

18", 24", and 36" HEIGHT



AMERICAN POLYMER COMPANY

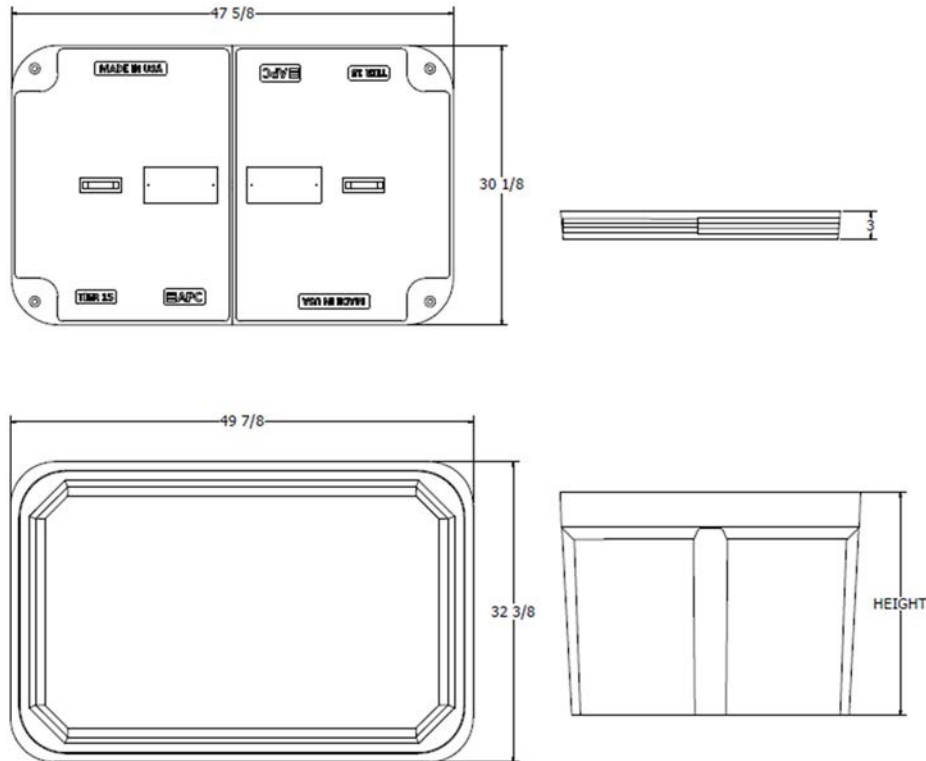

Components	Nominal Size	ANSI Tier	Part Number	Estimated Weight
Replacement Box	30"x48"x18"	Tier 22	P304818B22	185 lbs.
Replacement Box	30"x48"x24"	Tier 22	P304824B22	235 lbs.
Replacement Box	30"x48"x36"	Tier 22	P304836B22	340 lbs.
Replacement Lids - T15	30"x48" (half)	Tier 15	Various	150 lbs.
Replacement Lids - T22	30"x48" (half)	Tier 22	Various	170 lbs.

Bolt options

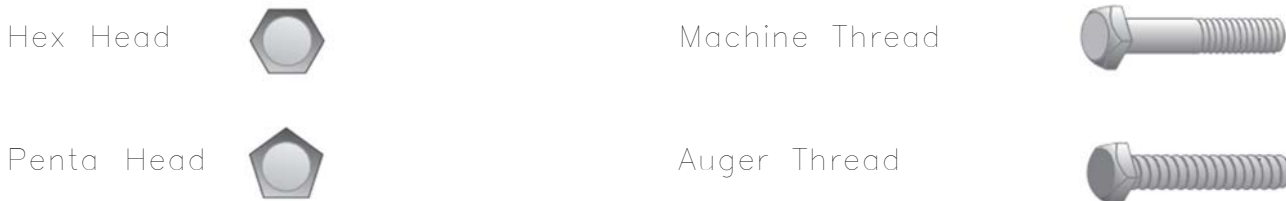

24"x36" PC UNIT, TIER 15/22
 18", 24", 30", and 36" HEIGHT



AMERICAN POLYMER COMPANY

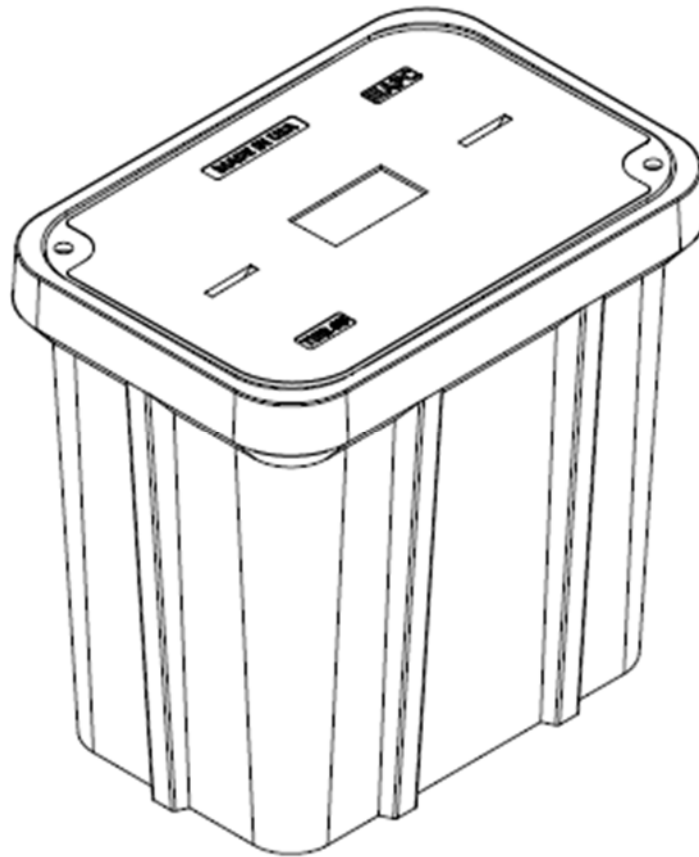

Description	Nominal Size	ANSI Tier	Part Number	Estimated Weight
PC Unit – TIER 15	24x36"x18"	Tier 15	P243618U15...	335 lbs.
PC Unit – TIER 22	24x36"x18"	Tier 22	P243618U22...	355 lbs.
PC Unit – TIER 15	24x36"x24"	Tier 15	P243624U15...	365 lbs.
PC Unit – TIER 22	24x36"x24"	Tier 22	P243624U22...	385 lbs.
PC Unit – TIER 15	24x36"x30"	Tier 15	P243630U15...	395 lbs.
PC Unit – TIER 22	24x36"x30"	Tier 22	P243630U22...	415 lbs.
PC Unit – TIER 15	24x36"x36"	Tier 15	P243636U15...	425 lbs.
PC Unit – TIER 22	24x36"x36"	Tier 22	P243636U22...	445 lbs.



24"x36" PC UNIT, TIER 15/22

18", 24", 30", and 36" HEIGHT



AMERICAN POLYMER COMPANY

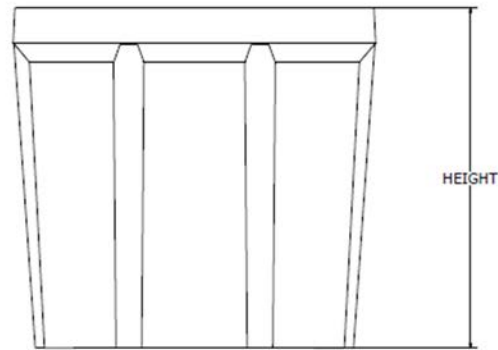
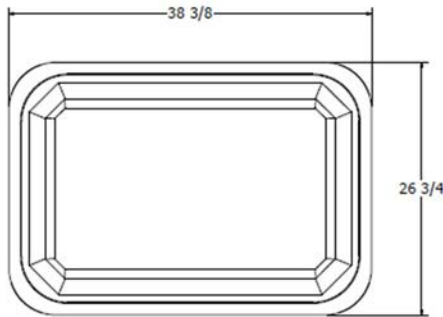
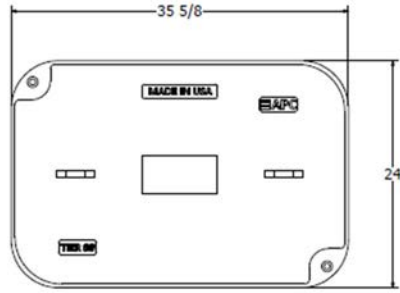

Components	Nominal Size	ANSI Tier	Part Number	Estimated Weight
Replacement Box	24"x36"x18"	Tier 22	P243618B22	165 lbs.
Replacement Box	24"x36"x24"	Tier 22	P243624B22	195 lbs.
Replacement Box	24"x36"x30"	Tier 22	P243630B22	225 lbs.
Replacement Box	24"x36"x36"	Tier 22	P243636B22	255 lbs.
Replacement Lids - T15	24"x36"	Tier 15	Various	170 lbs.
Replacement Lids - T22	24"x36"	Tier 22	Various	190 lbs.

Bolt options

Hex Head



Machine Thread



Penta Head



Auger Thread



17"x30" PC UNIT, TIER 15/22

12", 18", 24", and 30" HEIGHT



AMERICAN POLYMER COMPANY

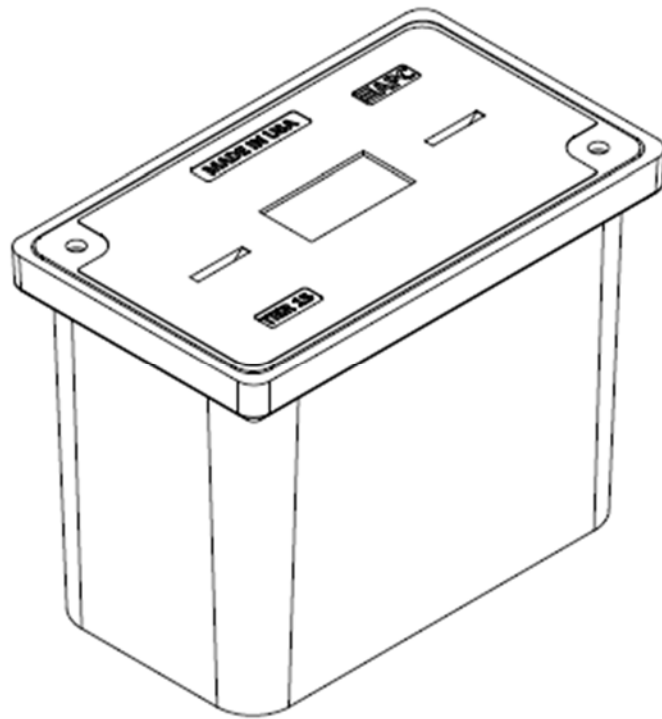

Description	Nominal Size	ANSI Tier	Part Number	Estimated Weight
PC Unit - TIER 15	17"x30"x12"	Tier 15	P173012U15...	138 lbs.
PC Unit - TIER 22	17"x30"x12"	Tier 22	P173012U22...	147 lbs.
PC Unit - TIER 15	17"x30"x18"	Tier 15	P173018U15...	172 lbs.
PC Unit - TIER 22	17"x30"x18"	Tier 22	P173018U22...	181 lbs.
PC Unit - TIER 15	17"x30"x24"	Tier 15	P173024U15...	192 lbs.
PC Unit - TIER 22	17"x30"x24"	Tier 22	P173024U22...	201 lbs.
PC Unit - TIER 15	17"x30"x30"	Tier 15	P173030U15...	217 lbs.
PC Unit - TIER 22	17"x30"x30"	Tier 22	P173030U22...	226 lbs.



17"x30" PC UNIT, TIER 15/22

12", 18", 24", and 30" HEIGHT



AMERICAN POLYMER COMPANY

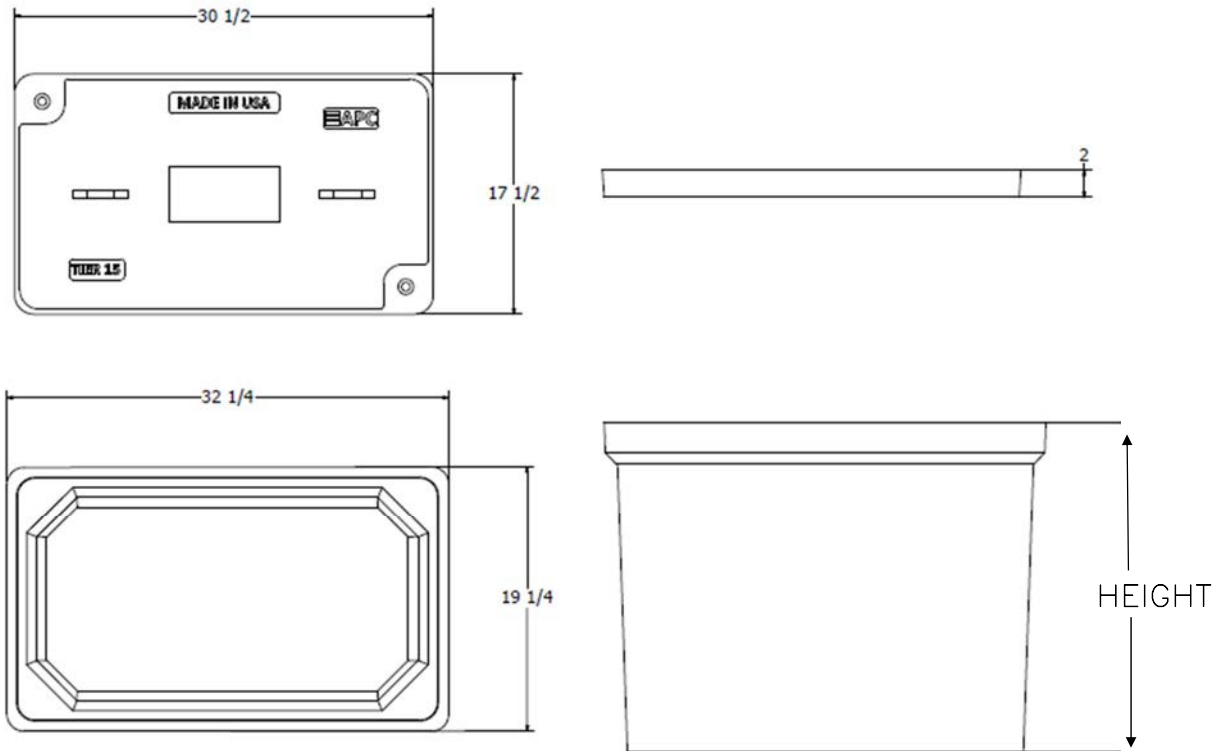

Components	Nominal Size	ANSI Tier	Part Number	Estimated Weight
Replacement Box	17"x30"x12"	Tier 22	P173012B22	66 lbs.
Replacement Box	17"x30"x18"	Tier 22	P173018B22	100 lbs.
Replacement Box	17"x30"x24"	Tier 22	P173024B22	120 lbs.
Replacement Box	17"x30"x30"	Tier 22	P173030B22	145 lbs.
Replacement Lids – T15	17"x30"	Tier 15	Various	72 lbs.
Replacement Lids – T22	17"x30"	Tier 22	Various	81 lbs.

Bolt options



Machine Thread



Auger Thread



33"x60" PC UNIT, 2PC TIER 15/22
36" HEIGHT



AMERICAN POLYMER COMPANY

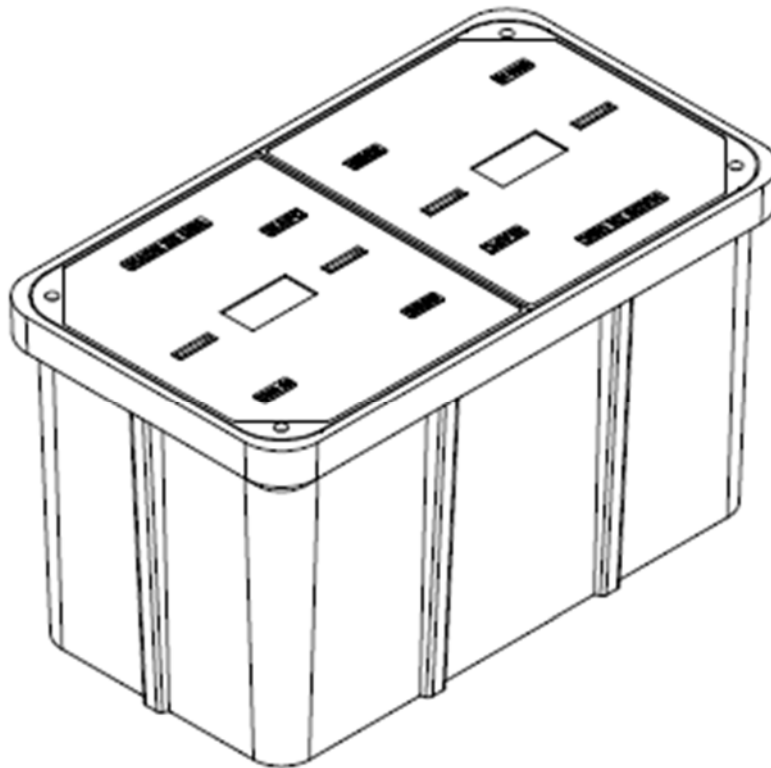

Description	Nominal Size	ANSI Tier	Part Number	Estimated Weight
PC Unit - TIER 15	33"x60"x36"	Tier 15	P336036U15...	930 lbs.
PC Unit - TIER 22	33"x60"x36"	Tier 22	P336036U22...	1030 lbs.



33"x60" PC UNIT, 2PC TIER 15/22

36" HEIGHT



AMERICAN POLYMER COMPANY

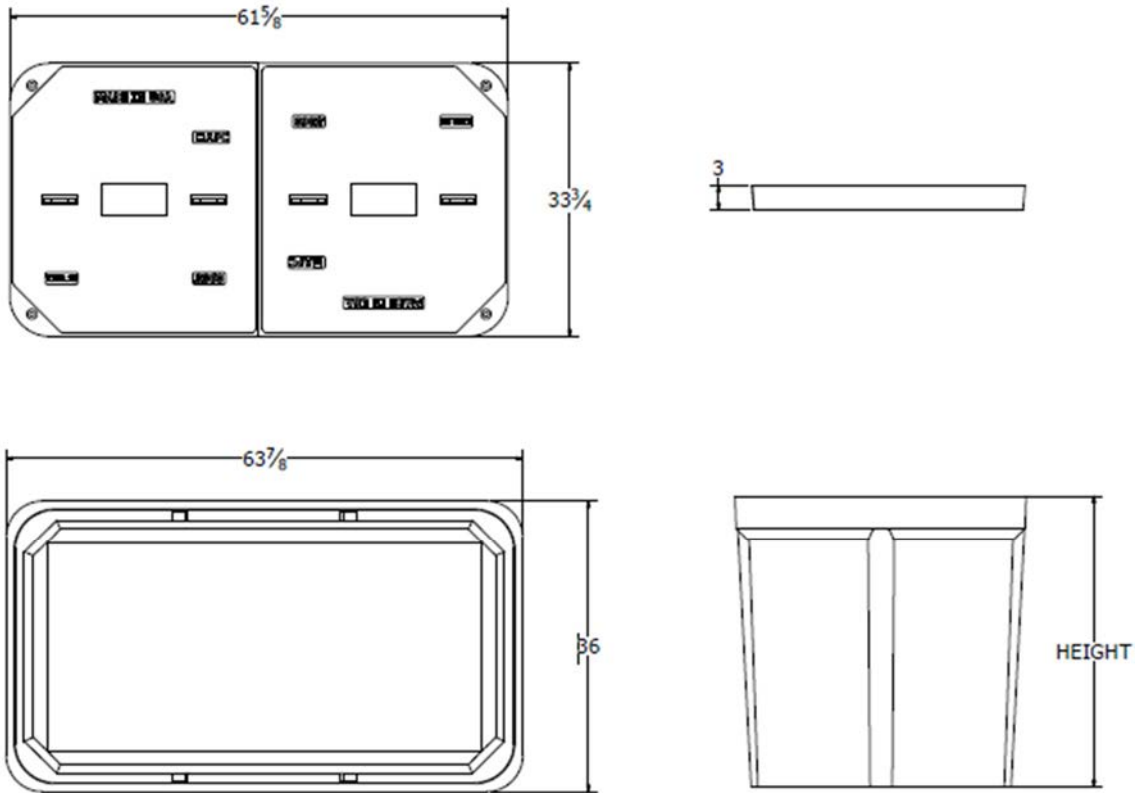

Components	Nominal Size	ANSI Tier	Part Number	Estimated Weight
Replacement Box	33"x60"x36"	Tier 22	P336036B22	530 lbs.
Replacement Lids - T15	33"x60" (half)	Tier 15	Various	200 lbs.
Replacement Lids - T22	33"x60" (half)	Tier 22	Various	250 lbs.

Bolt options

Hex Head



Machine Thread



Penta Head



Auger Thread



Speed (MPH) Prior To Road Work	SIGN SPACING, FT.		BUFFER SPACE, FT.	TAPER LENGTH, FT.		CHANNELIZING SPACING, FT.	
	Non-Divided Highways	Divided Highways	Length	Shoulder (10 ft. Width)	Lane (12 ft. Width)	Through Taper	Through Buffer/Work Area
	0-35	200	200	250	70	245	35
40-45	350	500	360	150	540	40	80
50-55	500	1000	495	185	660	50	100
60-70	SA-1000, SB-1500, SC-2640		730	235	840	60	120
Urban Low Speed - 100 FT							

APPROVED/ACCEPTED BY:
ENGINEER, OWNER, or PRIME CONTRACTOR
 Check for Notice to Proceed.
BLC02a-F14_S Maxwell St -TCP1

Signature: _____

Company: _____

Date: 1/18/2023 **Project:** BLC02a-F14 S Maxwell St -TCP :
: **Traffic Control Suggestion For:** AEG :
By: Road Runner Safety Services, Inc. : Nathan

Comments:
Drawing not to scale. Traffic control plan must be approved by an engineer. This is a suggestion only. Road Runners Safety Services, Inc. has no liability for this suggested traffic control plan. Actual placement and spacing of all traffic control devices will depend on field conditions and must conform to MUTCD standards.

- Legend**
- ADA Barricade
 - Channelizer
 - Conduit
 - Flagger (Person)
 - Overhead Strand
 - Sign
 - Vault
 - Work Area

Sheet 1

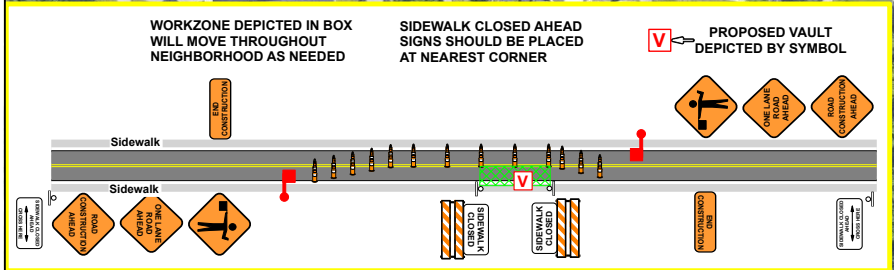
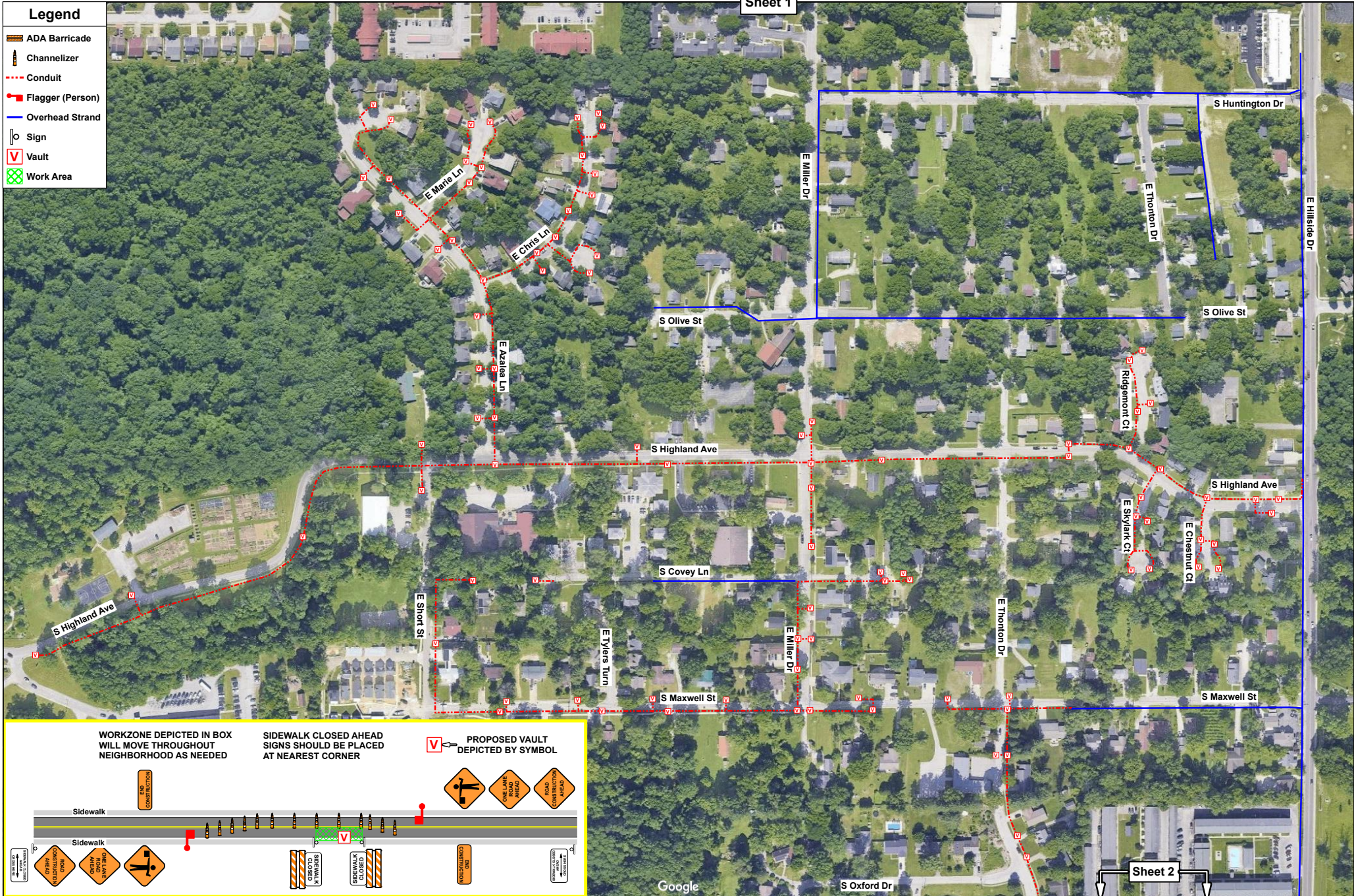

Sheet 2

Speed (MPH) Prior To Road Work	SIGN SPACING, FT.		Must be Approved by an Engineer				
	Non-Divided Highways	Divided Highways	BUFFER SPACE, FT.	TAPER LENGTH, FT.	CHANNELIZING SPACING, FT.		
	Length	Shoulder (10 ft. Width)	Lane (12 ft. Width)	Through Taper	Through Buffer/Work Area		
0-35	200	200	250	70	245	35	50
40-45	350	500	360	150	540	40	80
50-55	500	1000	495	185	660	50	100
60-70	SA-1000, SB-1500, SC-2640		730	235	840	60	120
	Urban Low Speed - 100 FT						

APPROVED/ACCEPTED BY:
ENGINEER, OWNER, or PRIME CONTRACTOR
 Check for Notice to Proceed.
BLC02a-F14_S Maxwell St -TCP2

Signature: _____

Company: _____



Date: 1/18/2023 Project: BLC02a-F14 S Maxwell St -TCP :
: Traffic Control Suggestion For: AEG :
By: Road Runner Safety Services, Inc. : Nathan

Comments:
Drawing not to scale. Traffic control plan must be approved by an engineer. This is a suggestion only. Road Runners Safety Services, Inc. has no liability for this suggested traffic control plan. Actual placement and spacing of all traffic control devices will depend on field conditions and must conform to MUTCD standards.

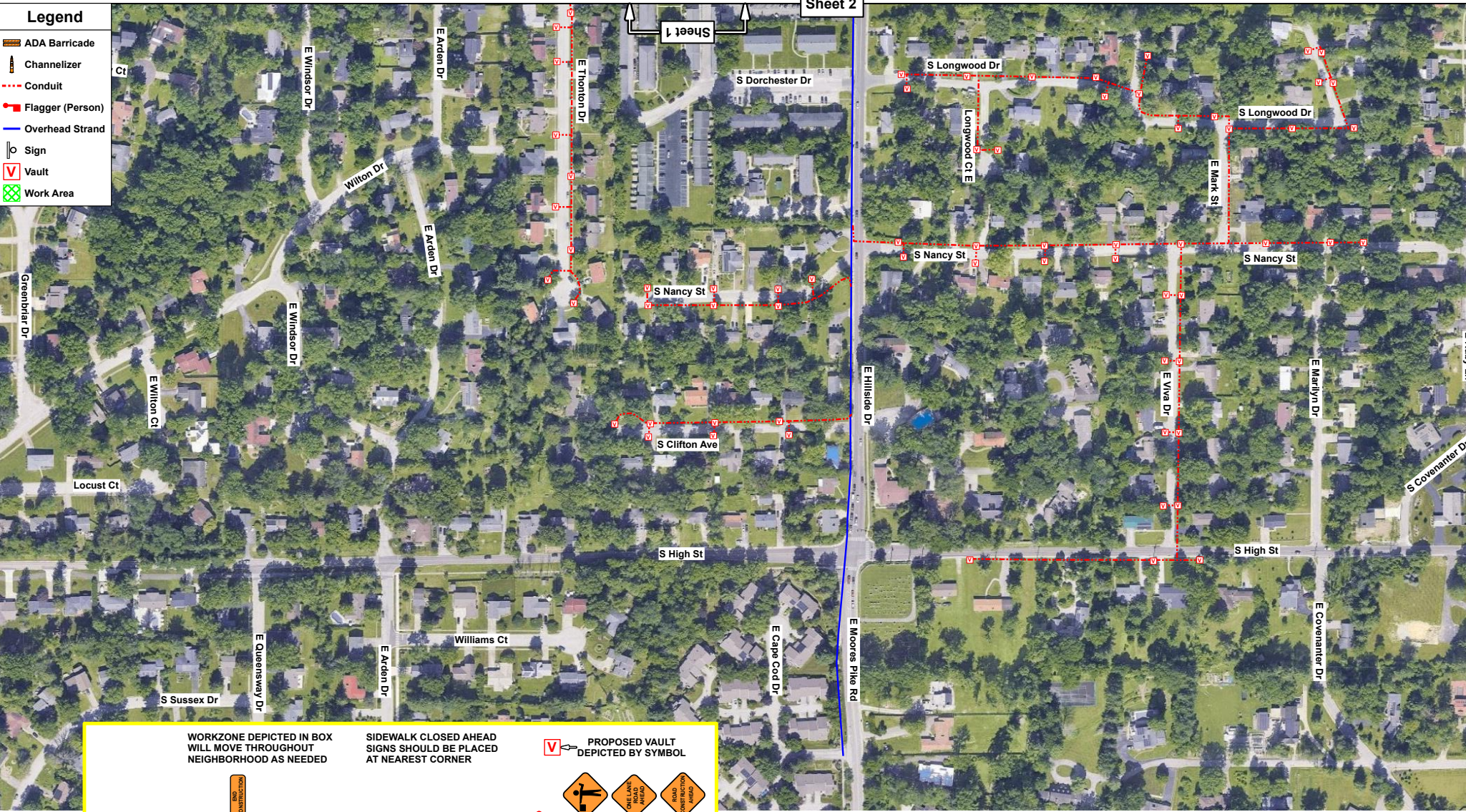

- Legend**
- ADA Barricade
 - Channelizer
 - Conduit
 - Flagger (Person)
 - Overhead Strand
 - Sign
 - Vault
 - Work Area

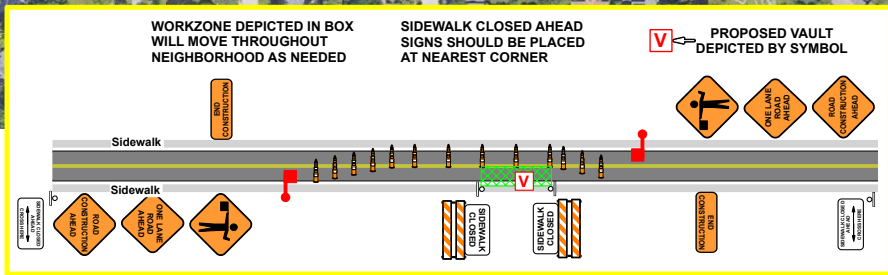

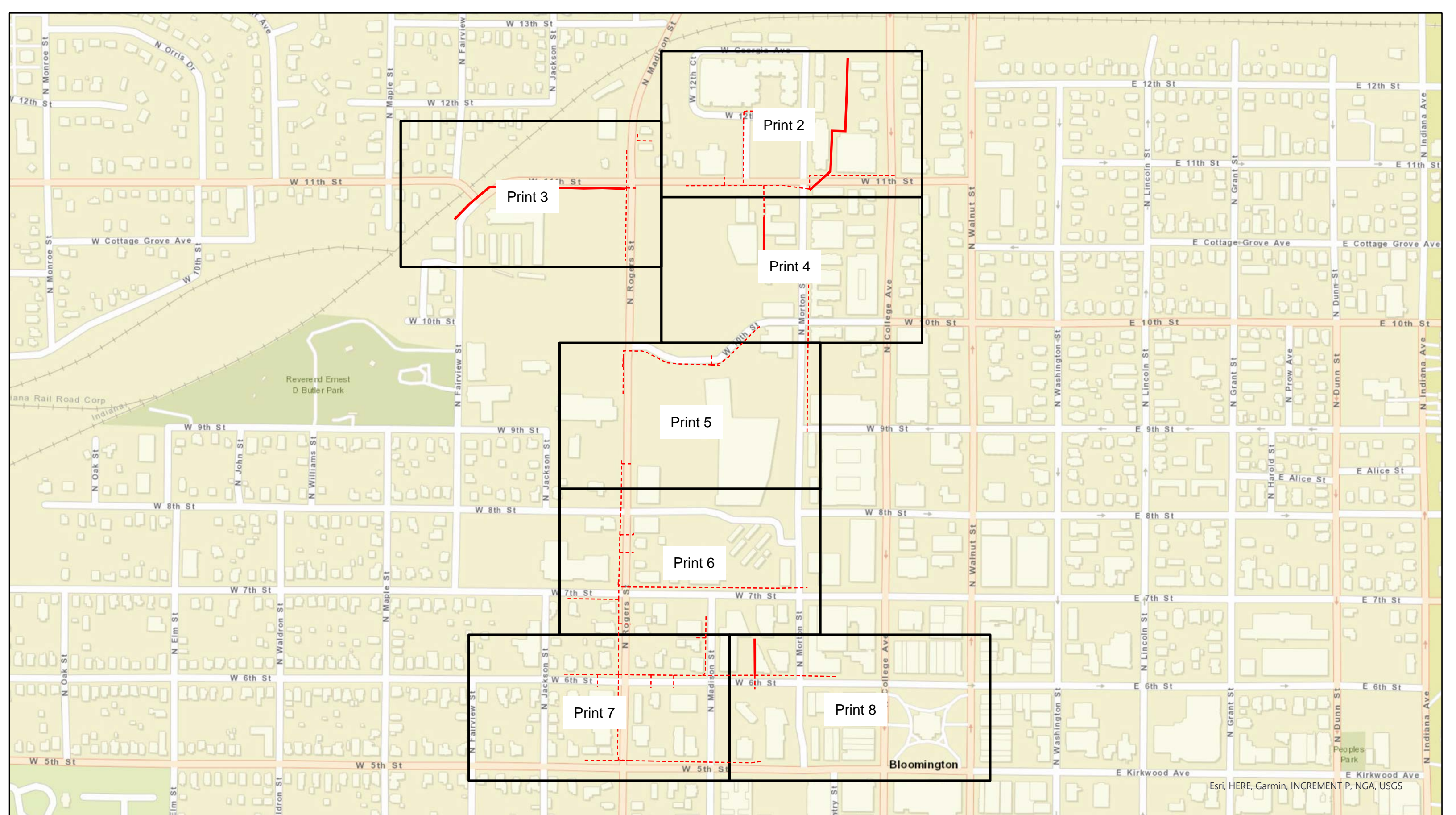

Esri, HERE, Garmin, INCREMENT P, NGA, USGS



Legend BLN01b-F10_N Morton St

- Proposed Aerial
- - - Conduit
- Grids

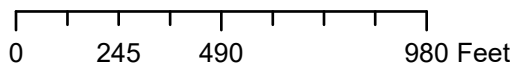

City of Bloomington, IN Permit:
Design View

INI	BY	DATE	DESCRIPTION



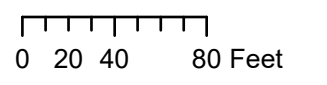
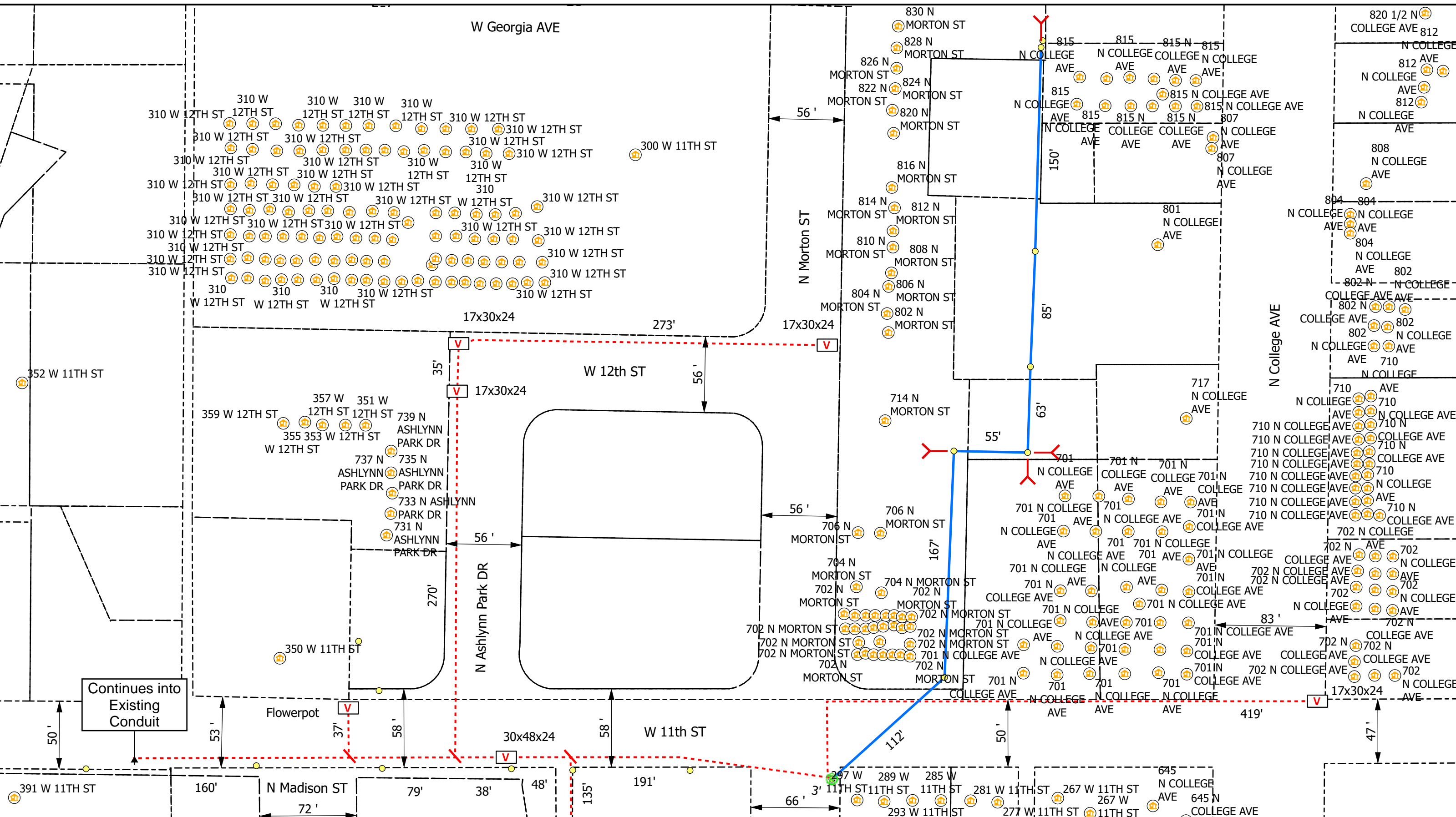

Legend

- Poles
- V Vaults
- Overhead Strand
- - - Conduit
- ⊕ Risers
- Ⓜ Address
- Y Anchor
- ↖ Sidewalk
- Bloomington_Parcels
- Grids

All Flowerpots 12" DIA



City of Bloomington, IN Permit:
Design View

INI	BY	DATE	DESCRIPTION



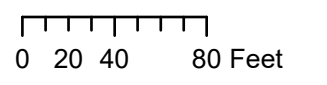
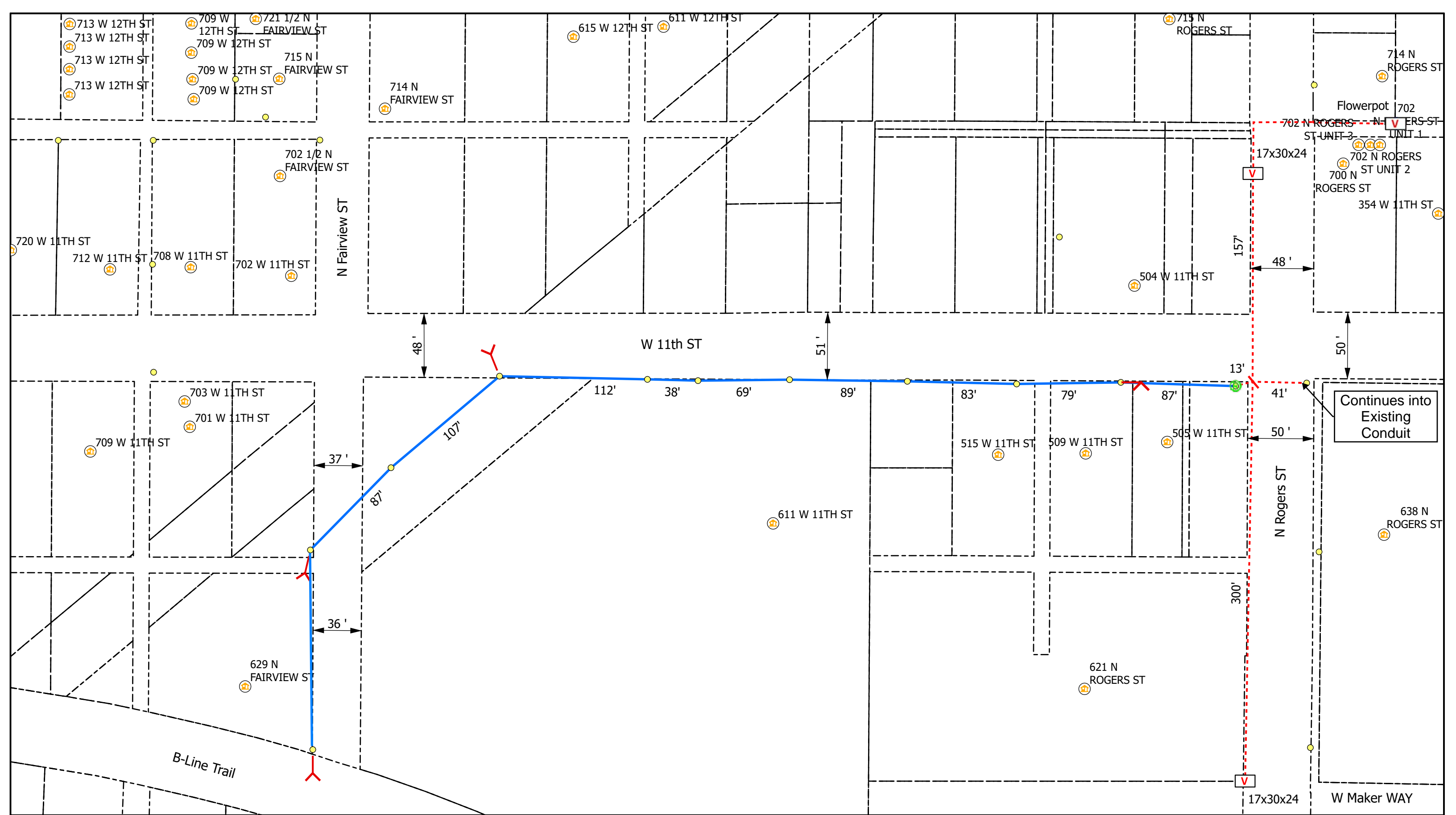

Legend

- Poles
- V Vaults
- Overhead Strand
- Conduit
- Risers
- 🏠 Address
- Y Anchor
- Y Sidewalk
- Bloomington_Parcels
- Grids

All Flowerpots 12" DIA



City of Bloomington, IN Permit:
Design View

INI	BY	DATE	DESCRIPTION



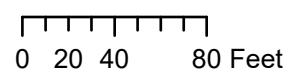
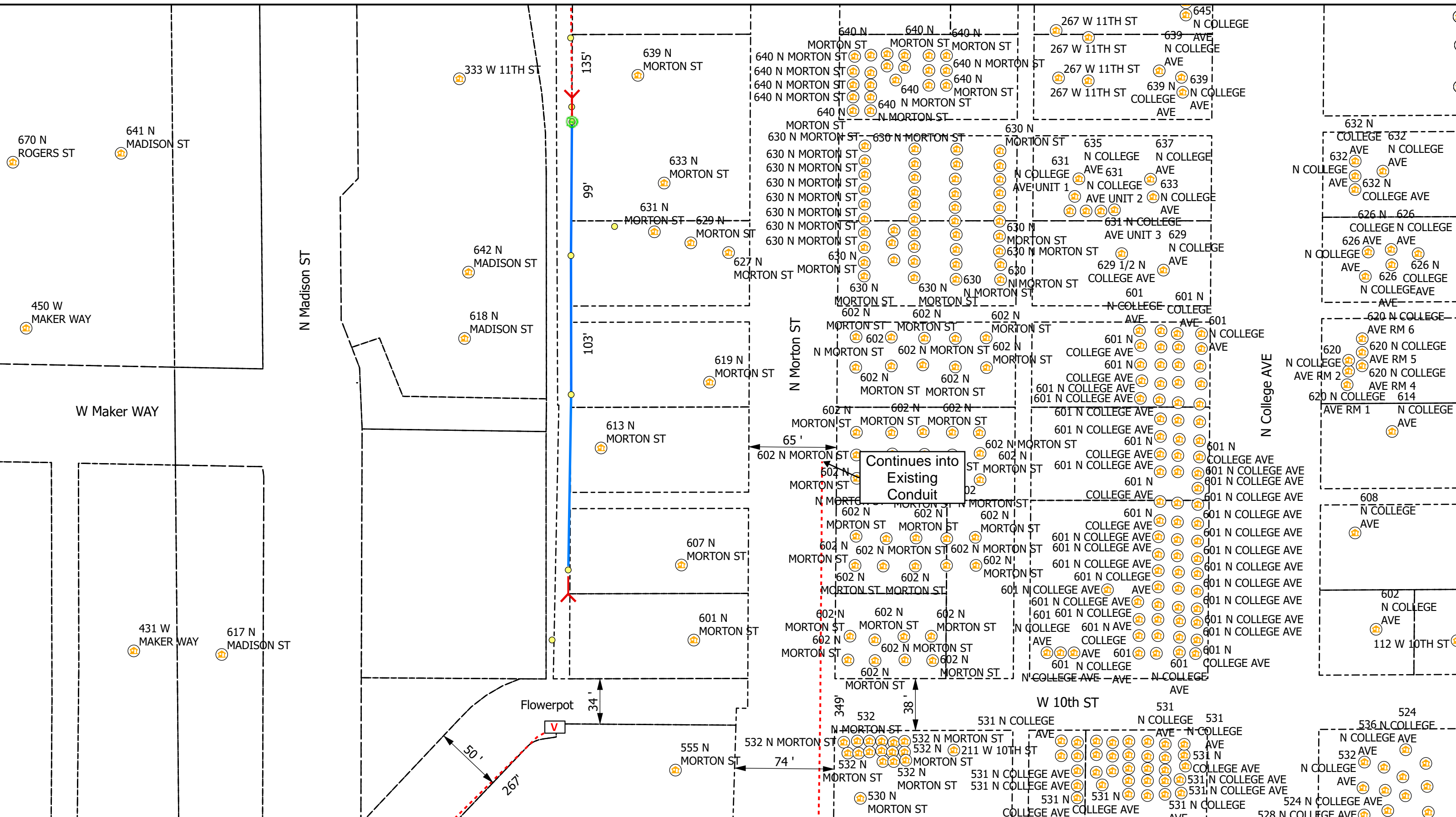

Legend

- Poles
- Ⓡ Risers
- Ⓜ Address
- Ⓜ Anchor
- V Vaults
- Overhead Strand
- Conduit
- ↖ Sidewalk
- Bloomington_Parcels
- Grids

All Flowerpots 12" DIA



City of Bloomington, IN Permit:
Design View

INI	BY	DATE	DESCRIPTION



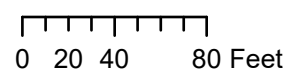
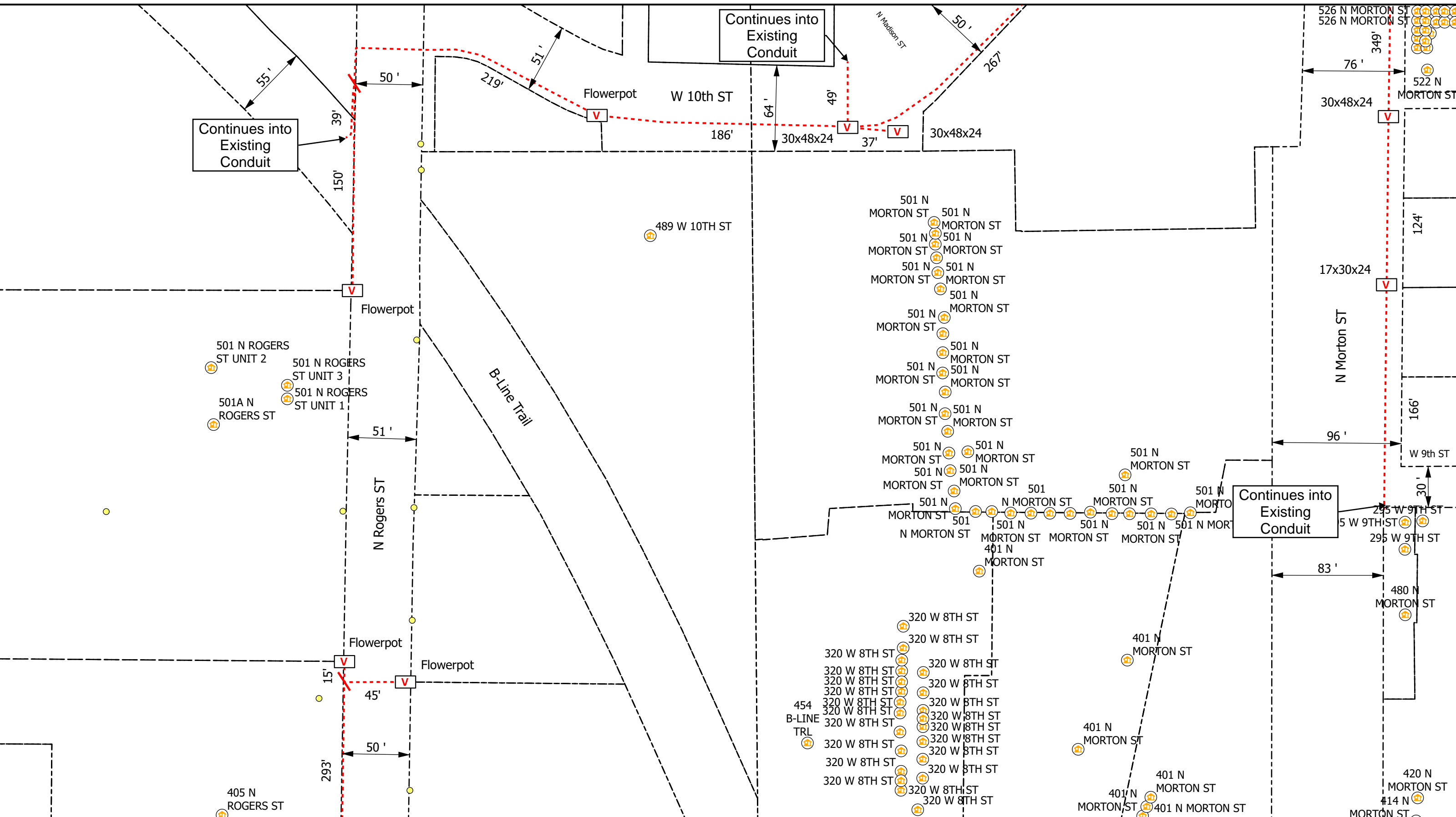

Legend

- Poles
- ⊕ Risers
- V Vaults
- Overhead Strand
- - - Conduit
- ↖ Sidewalk
- Bloomington_Parcels
- Grids
- Ⓜ Address
- Y Anchor

All Flowerpots 12" DIA



City of Bloomington, IN Permit:
Design View

INI	BY	DATE	DESCRIPTION



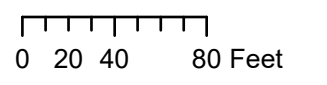
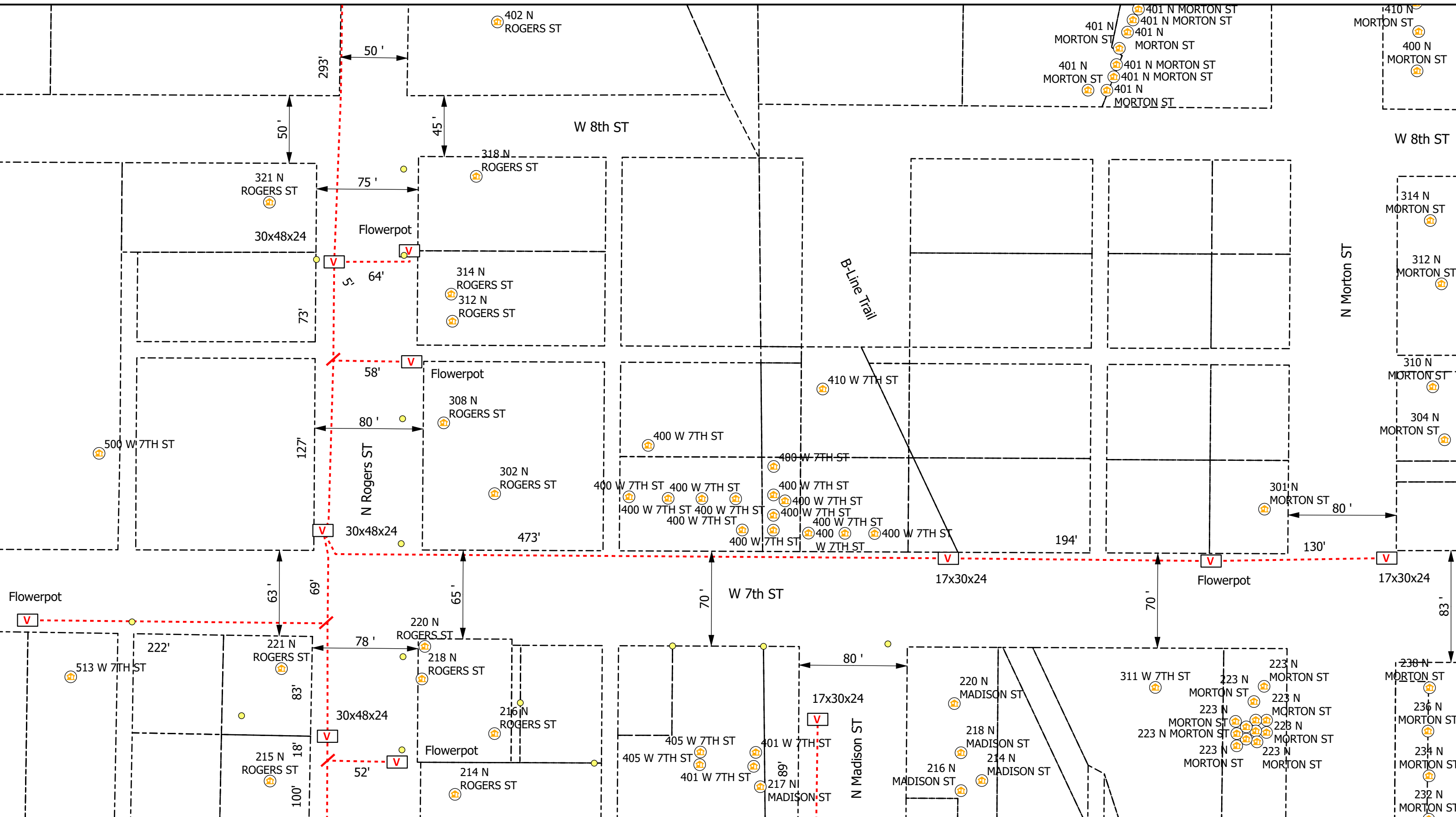

Legend

- Poles
- V Vaults
- Overhead Strand
- Conduit
- Ⓡ Risers
- 🏠 Address
- Y Anchor
- ↖ Sidewalk
- Bloomington_Parcels
- Grids

All Flowerpots 12" DIA



City of Bloomington, IN Permit:
Design View

INI	BY	DATE	DESCRIPTION



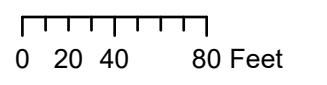
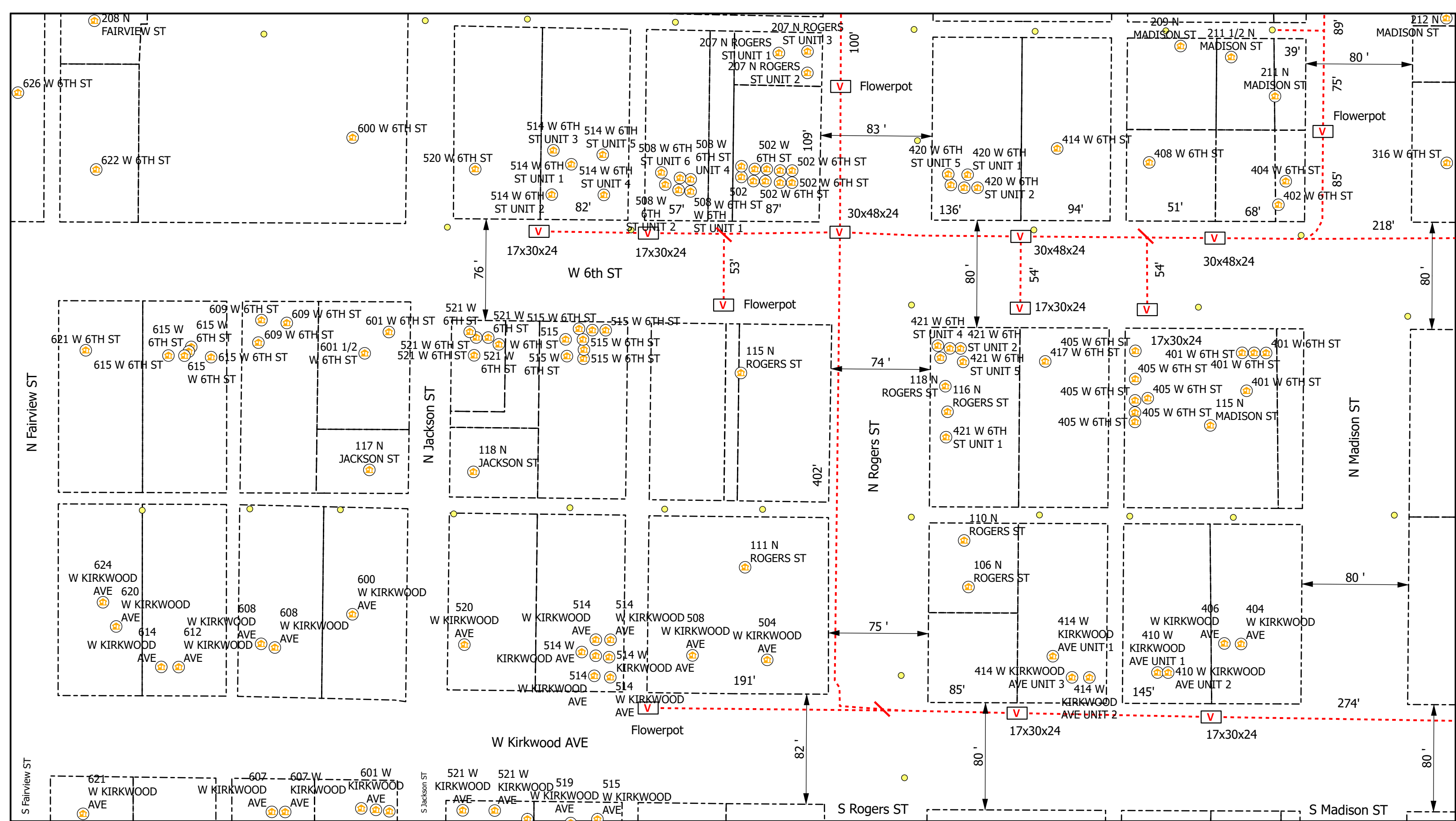

Legend

- Poles
- Vaults
- Overhead Strand
- Conduit
- Risers
- Address
- Anchor
- Sidewalk
- Bloomington_Parcels
- Grids

All Flowerpots 12" DIA



City of Bloomington, IN Permit:
Design View

INI	BY	DATE	DESCRIPTION



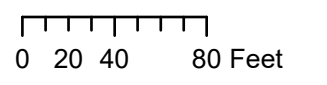
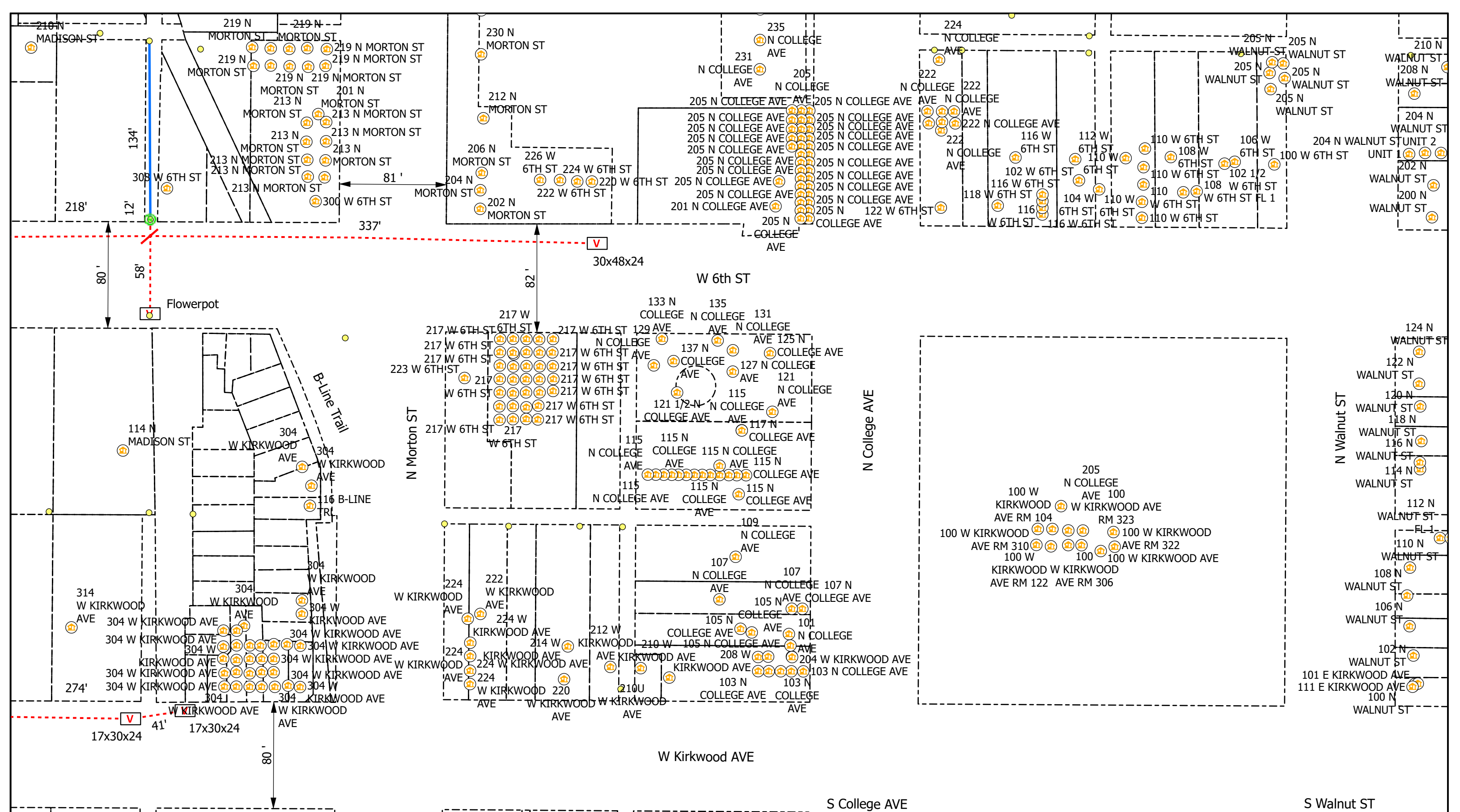

Legend

- Poles
- R Risers
- V Vaults
- Overhead Strand
- Conduit
- ↖ Sidewalk
- Bloomington_Parcels
- Grids
- 🏠 Address
- Y Anchor

All Flowerpots 12" DIA



City of Bloomington, IN Permit:
Design View

INI	BY	DATE	DESCRIPTION



Carlton® PV-Mold® Nonmetallic Pole Riser System

Carlton PV-Mold is a nonmetallic pole riser system designed to protect communications power cable installed on poles.

Features:

- Meets or exceeds requirements outlined in the National Electric Safety Code (NESC).
- Designed in accordance with NEMA TC-19 specifications.
- Ultraviolet, cold temperature and corrosive atmosphere resistant.
- Schedule 40 wall meets Schedule 80 PVC conduit impact requirements per NEMA TC-19.
- No grounding required.
- Belled end fits over each added section or conduit.
- Flame retardant.
- Requires no maintenance.
- PV-Mold acts as an insulator against electrical shock.
- Interchangeable parts and accessories to match the needs of specific requirements.



Steel U-Guard requires grounding strapping and does not have belled ends.



PV-Mold has belled ends, flanged design and does not require grounding.

Flanged Overall Length 10 Feet, Including Bell

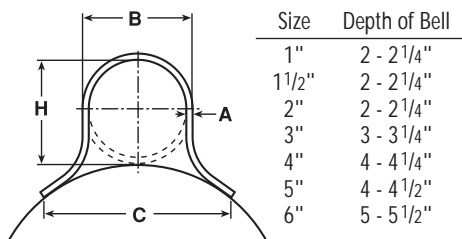

Slots are 1/2" from side to side, and allow for expansion and contraction.

Slot Dimensions: for sizes 2" through 6" are 5/16" wide, 3/4" long.

Slot Dimensions: for 1" and 1 1/2" are 3/16" wide, 3/4" long.

Slot Spacing: 18" from center, beginning 6" from end.

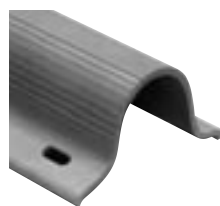

Standard Duty

Part No.	Size	Std. Ctn. Qty.	Std. Ctn. Wt. (lbs.)	Dimensions				Actual Impact @ 0°C 20 Pound Top
				A	B	C	H	
59208N	1"	294	1059	0.100"	1 5/8"	2 3/8"	1 5/8"	40 Ft.-Lbs.
59211N	2"	136	726	0.100"	2 3/8"	4 1/2"	2 3/8"	100 Ft.-Lbs.
59211X (5' length)	2"	136	363	0.100"	2 3/8"	4 1/2"	2 3/8"	100 Ft.-Lbs.
59213N	3"	66	761	0.150"	3 1/2"	6"	3 1/2"	110 Ft.-Lbs.
59213X (5' length)	3"	66	381	0.150"	3 1/2"	6"	3 1/2"	100 Ft.-Lbs.
59215N	4"	65	910	0.150"	4 1/2"	6 1/2"	4 1/2"	110 Ft.-Lbs.
59216N	5"	30	515	0.150"	5 1/2"	7 1/2"	5 1/2"	110 Ft.-Lbs.

Heavy Duty Schedule 40

59010N	1 1/2"	200	1142	0.145"	1 29/32"	3 1/2"	1 29/32"	100 Ft.-Lbs.
59011N	2"	136	1214	0.154"	2 3/8"	4 1/2"	2 3/8"	150 Ft.-Lbs.
59013N	3"	66	937	0.216"	3 1/2"	6"	3 9/32"	150 Ft.-Lbs.
59015N	4"	65	1621	0.237"	4 1/2"	6 1/2"	4 1/2"	260 Ft.-Lbs.
59015X (5' length)	4"	65	707	0.237"	4 1/2"	6 1/2"	4 1/2"	260 Ft.-Lbs.
59016N	5"	30	870	0.258"	5 1/2"	7 1/2"	5 1/2"	260 Ft.-Lbs.
59017N	6"	30	1160	0.280"	6 5/8"	8 3/4"	6 5/8"	260 Ft.-Lbs.

Extra Heavy Duty Schedule 80

59411N	2"	136	1549	0.218"	2 3/8"	4 1/2"	2 3/8"	300 Ft.-Lbs.
59413N	3"	66	1495	0.030"	3 1/2"	6"	3 1/2"	525 Ft.-Lbs.

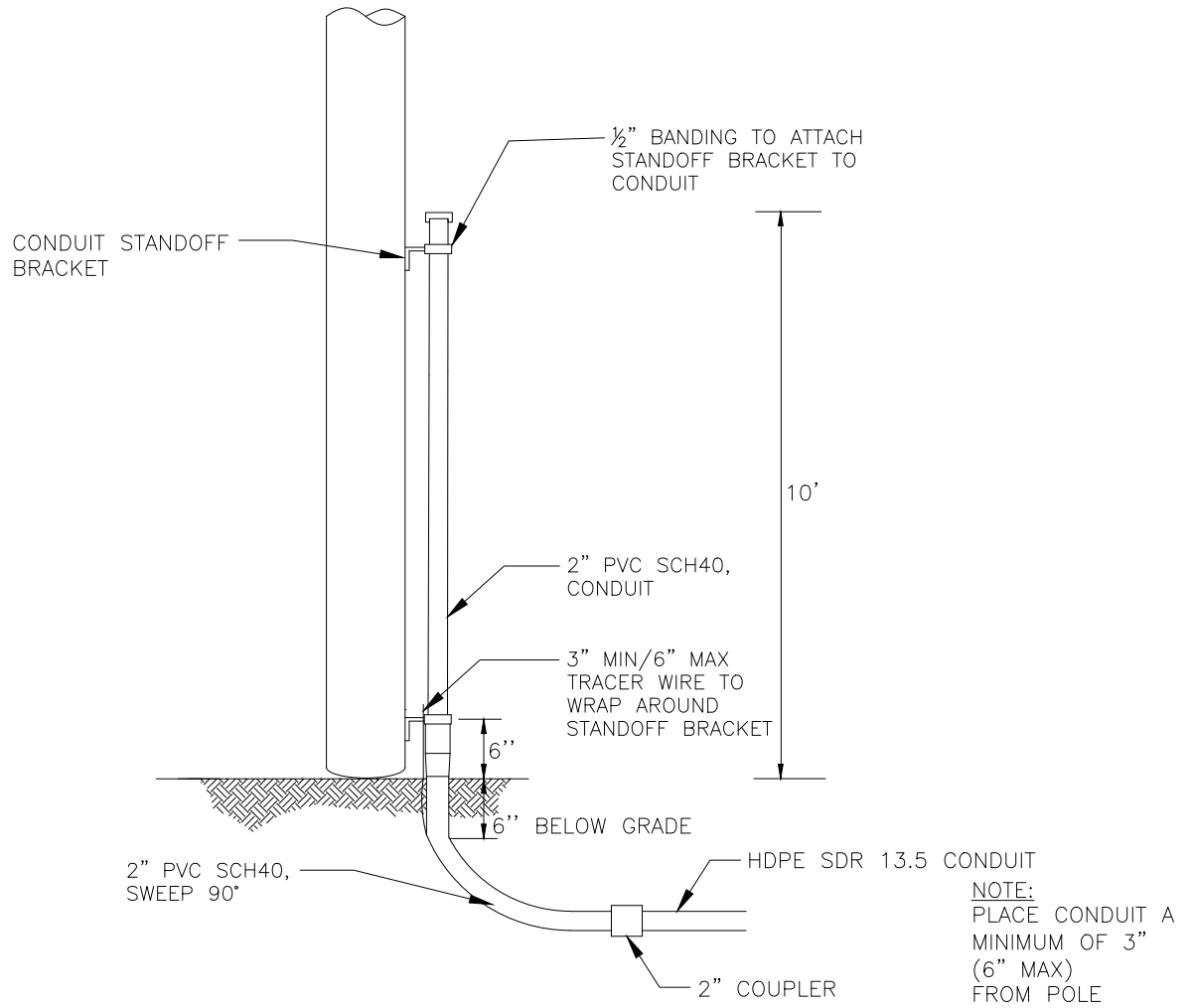

DESCRIPTION	QTY	MANUFACTURER (PREFERRED)	PART #
SCREW, LAG, 1/2" x 4-1/2"	10		
HDPE SDR 13.5 CONDUIT, VARIOUS SIZES	N/A		
2" PVC SCH40, RISER PIPE	1		
#12 TRACER WIRE	N/A		
2" PVC SCH40, SWEEP, 90 DEG	1		
CONDUIT STANDOFF BRACKET	VARIES		
CONDUIT STRAP KIT	VARIES		
2" COUPLER	1		



TYPICAL RISER
CONDUIT
WOOD POLE

(R2-W)

CONCEPTUAL SIDE VIEW

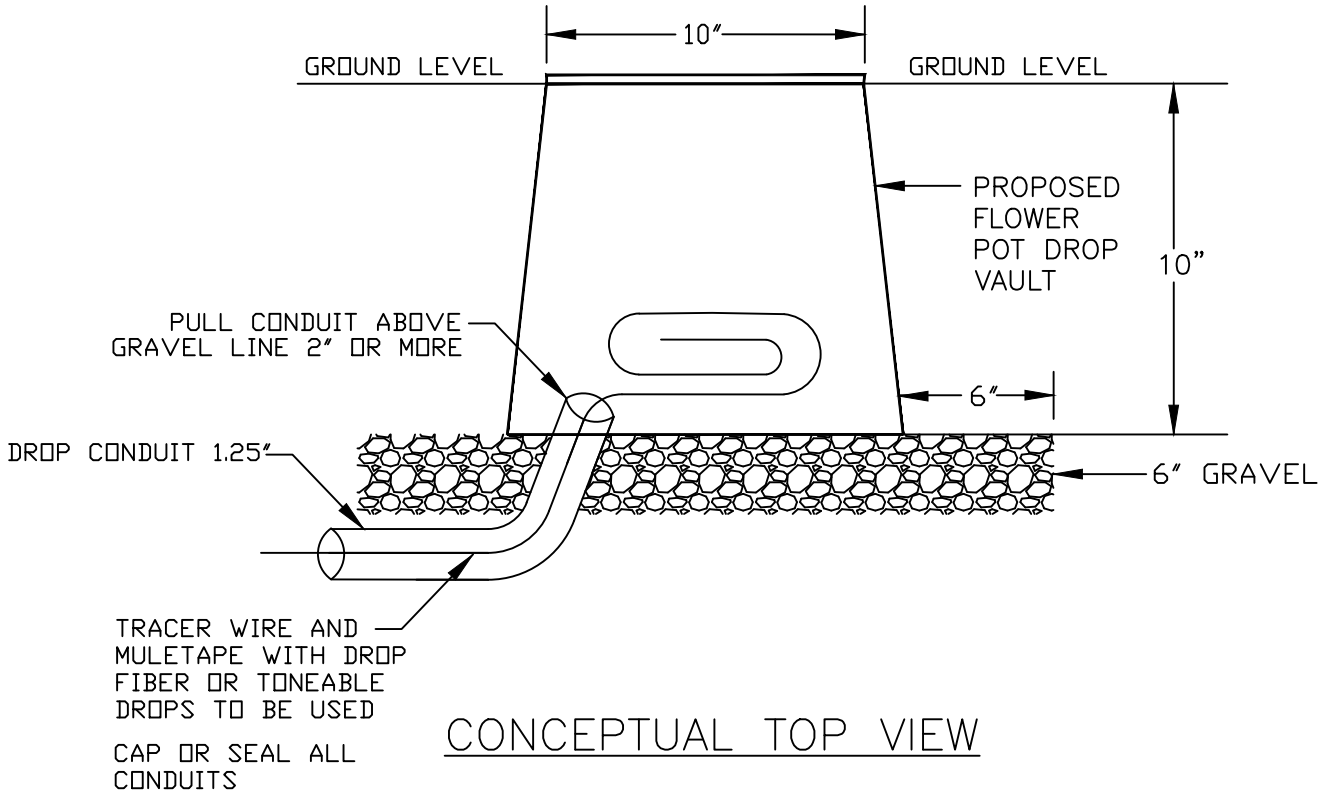

CONCEPTUAL TOP VIEW

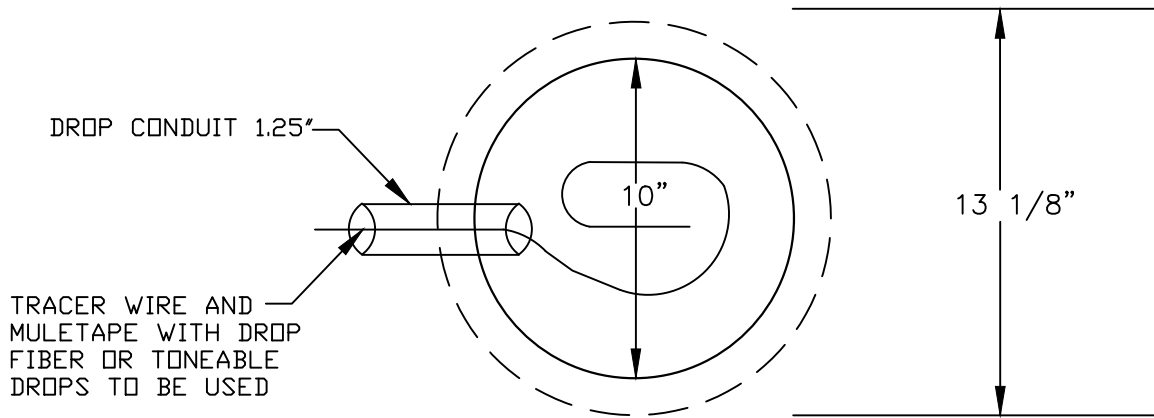

FLOWER POT

30"x48" PC UNIT, 2PC TIER 15/22
 18", 24", and 36" HEIGHT



AMERICAN POLYMER COMPANY

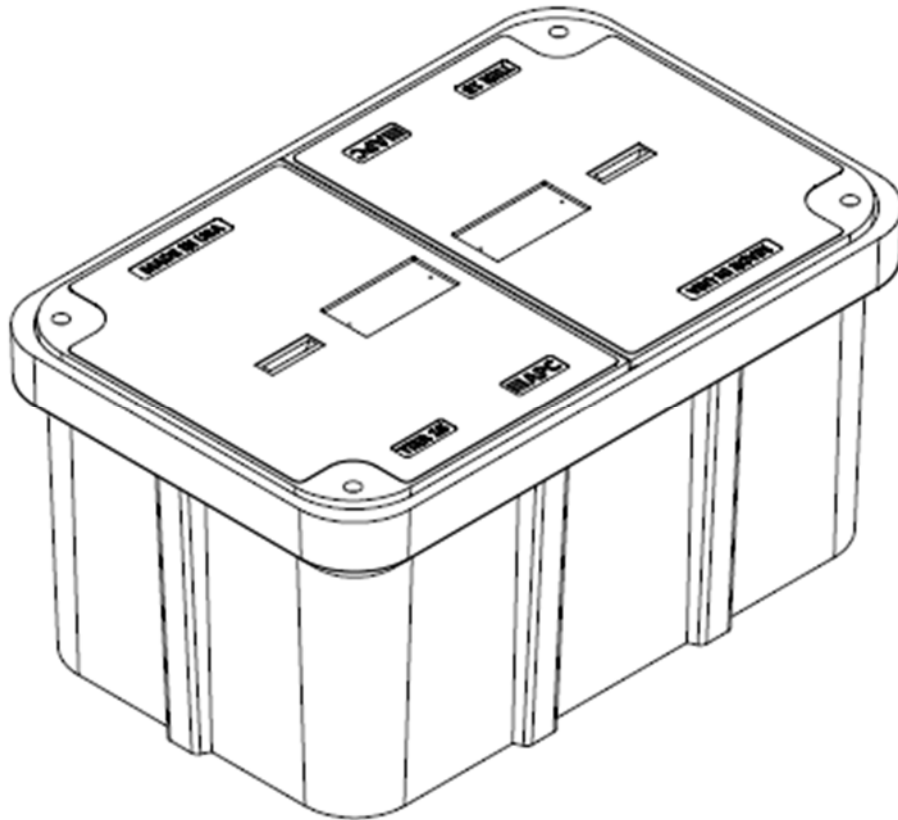

Description	Nominal Size	ANSI Tier	Part Number	Estimated Weight
PC Unit – TIER 15	30"x48"x18"	Tier 15	P304818HU15...	460 lbs.
PC Unit – TIER 22	30"x48"x18"	Tier 22	P304818HU22...	525 lbs.
PC Unit – TIER 15	30"x48"x24"	Tier 15	P304824HU15...	510 lbs.
PC Unit – TIER 22	30"x48"x24"	Tier 22	P304824HU22...	575 lbs.
PC Unit – TIER 15	30"x48"x36"	Tier 15	P304836HU15...	615 lbs.
PC Unit – TIER 22	30"x48"x36"	Tier 22	P304836HU22...	680 lbs.



30"x48" PC UNIT, 2PC TIER 15/22

18", 24", and 36" HEIGHT



AMERICAN POLYMER COMPANY

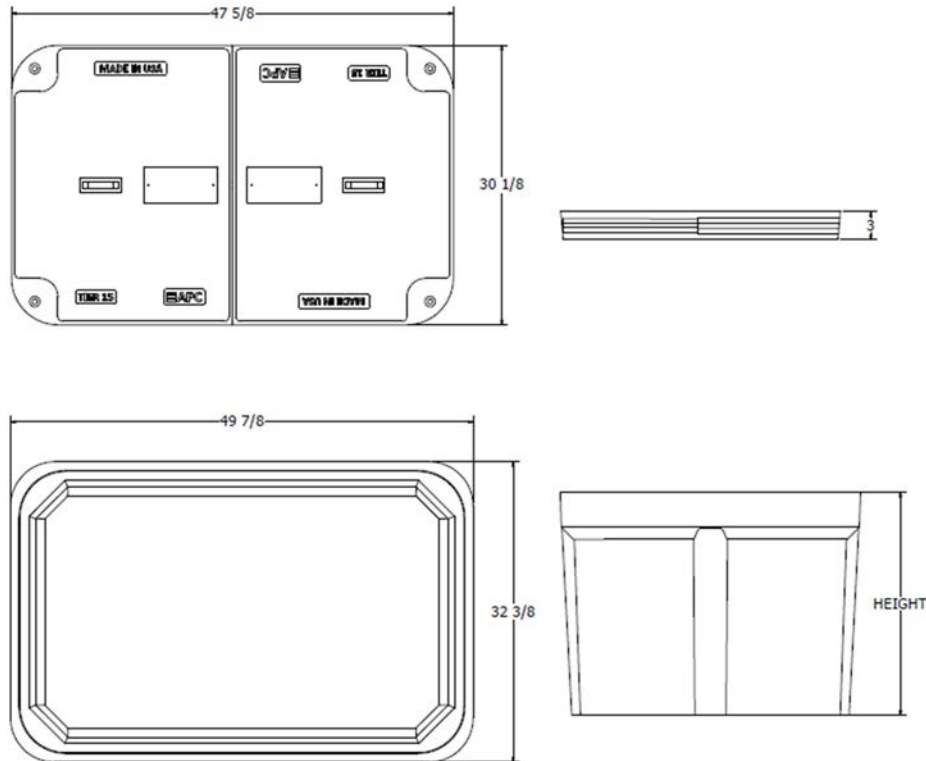

Components	Nominal Size	ANSI Tier	Part Number	Estimated Weight
Replacement Box	30"x48"x18"	Tier 22	P304818B22	185 lbs.
Replacement Box	30"x48"x24"	Tier 22	P304824B22	235 lbs.
Replacement Box	30"x48"x36"	Tier 22	P304836B22	340 lbs.
Replacement Lids - T15	30"x48" (half)	Tier 15	Various	150 lbs.
Replacement Lids - T22	30"x48" (half)	Tier 22	Various	170 lbs.

Bolt options

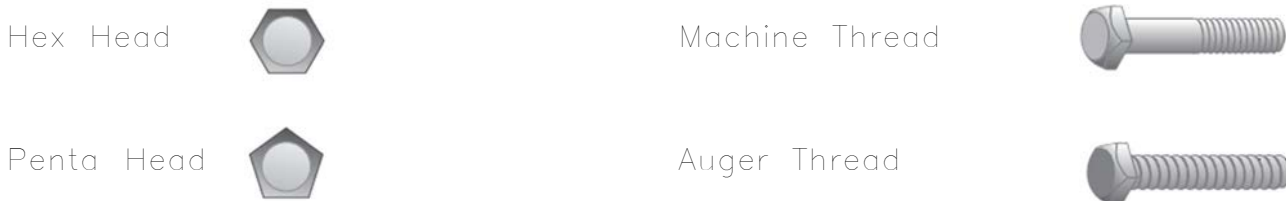

24"x36" PC UNIT, TIER 15/22
 18", 24", 30", and 36" HEIGHT



AMERICAN POLYMER COMPANY

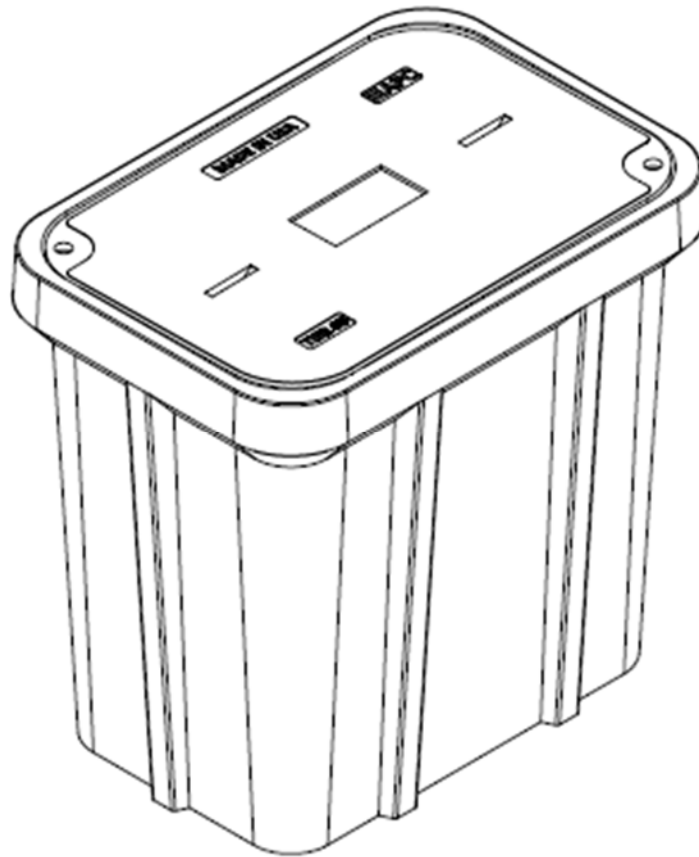

Description	Nominal Size	ANSI Tier	Part Number	Estimated Weight
PC Unit – TIER 15	24x36"x18"	Tier 15	P243618U15...	335 lbs.
PC Unit – TIER 22	24x36"x18"	Tier 22	P243618U22...	355 lbs.
PC Unit – TIER 15	24x36"x24"	Tier 15	P243624U15...	365 lbs.
PC Unit – TIER 22	24x36"x24"	Tier 22	P243624U22...	385 lbs.
PC Unit – TIER 15	24x36"x30"	Tier 15	P243630U15...	395 lbs.
PC Unit – TIER 22	24x36"x30"	Tier 22	P243630U22...	415 lbs.
PC Unit – TIER 15	24x36"x36"	Tier 15	P243636U15...	425 lbs.
PC Unit – TIER 22	24x36"x36"	Tier 22	P243636U22...	445 lbs.



24"x36" PC UNIT, TIER 15/22

18", 24", 30", and 36" HEIGHT



AMERICAN POLYMER COMPANY

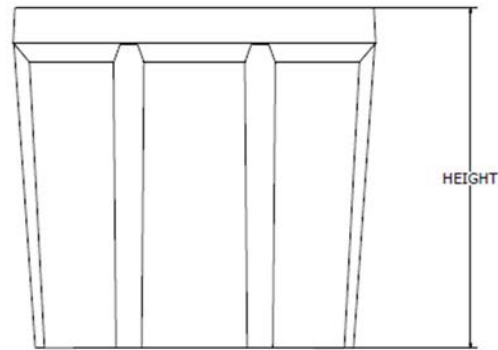
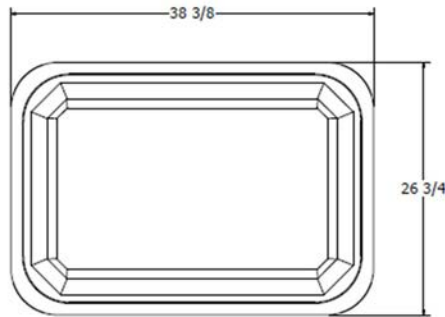
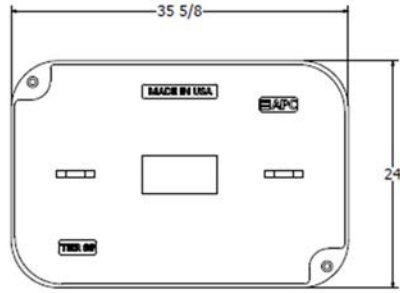

Components	Nominal Size	ANSI Tier	Part Number	Estimated Weight
Replacement Box	24"x36"x18"	Tier 22	P243618B22	165 lbs.
Replacement Box	24"x36"x24"	Tier 22	P243624B22	195 lbs.
Replacement Box	24"x36"x30"	Tier 22	P243630B22	225 lbs.
Replacement Box	24"x36"x36"	Tier 22	P243636B22	255 lbs.
Replacement Lids - T15	24"x36"	Tier 15	Various	170 lbs.
Replacement Lids - T22	24"x36"	Tier 22	Various	190 lbs.

Bolt options

Hex Head



Machine Thread



Penta Head



Auger Thread



17"x30" PC UNIT, TIER 15/22

12", 18", 24", and 30" HEIGHT



AMERICAN POLYMER COMPANY

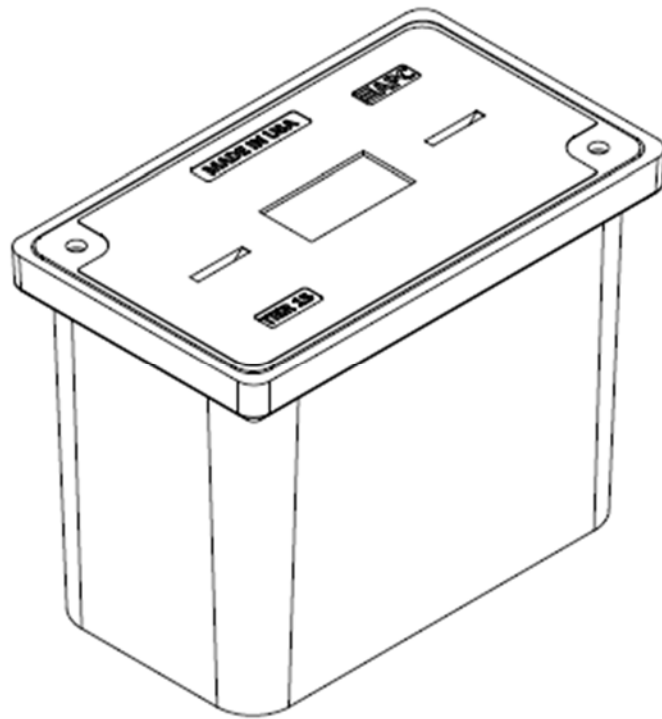

Description	Nominal Size	ANSI Tier	Part Number	Estimated Weight
PC Unit - TIER 15	17"x30"x12"	Tier 15	P173012U15...	138 lbs.
PC Unit - TIER 22	17"x30"x12"	Tier 22	P173012U22...	147 lbs.
PC Unit - TIER 15	17"x30"x18"	Tier 15	P173018U15...	172 lbs.
PC Unit - TIER 22	17"x30"x18"	Tier 22	P173018U22...	181 lbs.
PC Unit - TIER 15	17"x30"x24"	Tier 15	P173024U15...	192 lbs.
PC Unit - TIER 22	17"x30"x24"	Tier 22	P173024U22...	201 lbs.
PC Unit - TIER 15	17"x30"x30"	Tier 15	P173030U15...	217 lbs.
PC Unit - TIER 22	17"x30"x30"	Tier 22	P173030U22...	226 lbs.



17"x30" PC UNIT, TIER 15/22

12", 18", 24", and 30" HEIGHT



AMERICAN POLYMER COMPANY

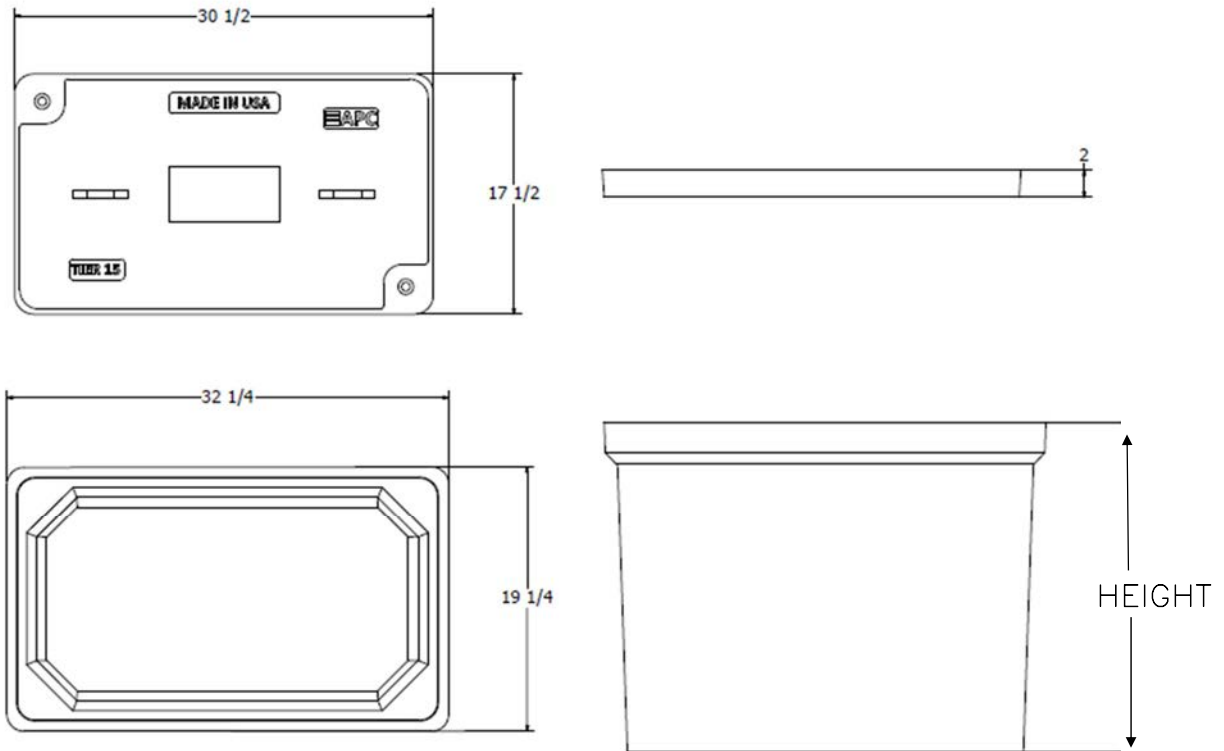

Components	Nominal Size	ANSI Tier	Part Number	Estimated Weight
Replacement Box	17"x30"x12"	Tier 22	P173012B22	66 lbs.
Replacement Box	17"x30"x18"	Tier 22	P173018B22	100 lbs.
Replacement Box	17"x30"x24"	Tier 22	P173024B22	120 lbs.
Replacement Box	17"x30"x30"	Tier 22	P173030B22	145 lbs.
Replacement Lids - T15	17"x30"	Tier 15	Various	72 lbs.
Replacement Lids - T22	17"x30"	Tier 22	Various	81 lbs.

Bolt options



Machine Thread



Auger Thread



33"x60" PC UNIT, 2PC TIER 15/22
36" HEIGHT



AMERICAN POLYMER COMPANY

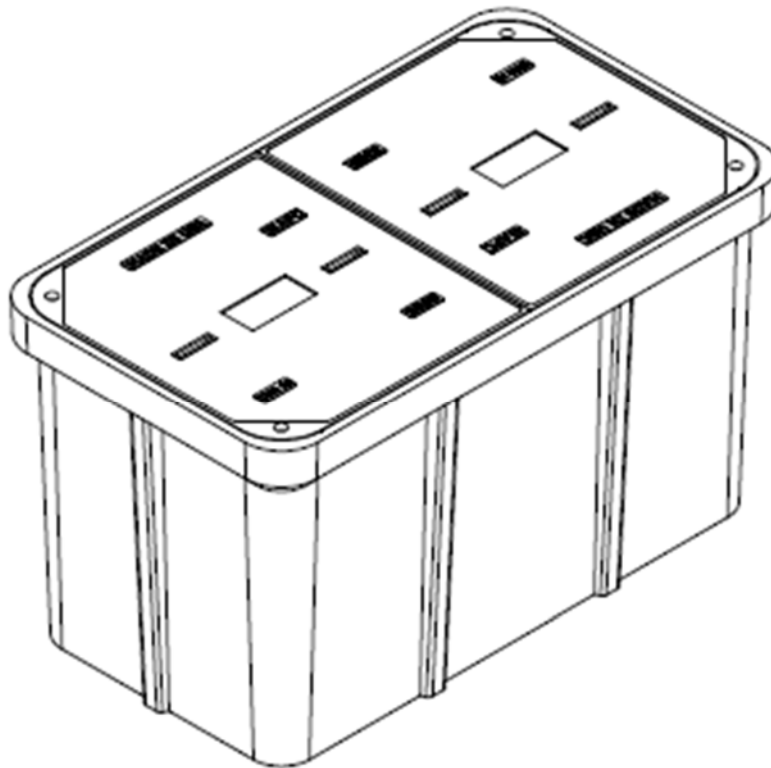

Description	Nominal Size	ANSI Tier	Part Number	Estimated Weight
PC Unit - TIER 15	33"x60"x36"	Tier 15	P336036U15...	930 lbs.
PC Unit - TIER 22	33"x60"x36"	Tier 22	P336036U22...	1030 lbs.



33"x60" PC UNIT, 2PC TIER 15/22

36" HEIGHT



AMERICAN POLYMER COMPANY

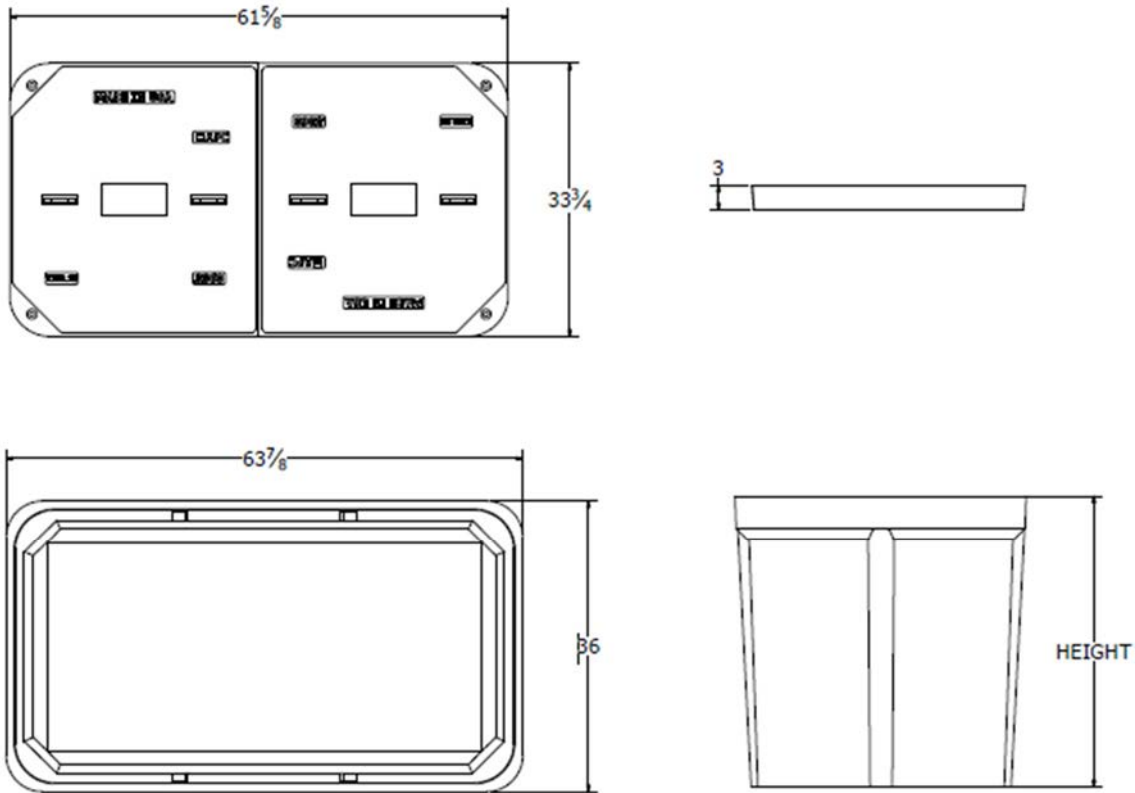

Components	Nominal Size	ANSI Tier	Part Number	Estimated Weight
Replacement Box	33"x60"x36"	Tier 22	P336036B22	530 lbs.
Replacement Lids - T15	33"x60" (half)	Tier 15	Various	200 lbs.
Replacement Lids - T22	33"x60" (half)	Tier 22	Various	250 lbs.

Bolt options

Hex Head



Machine Thread



Penta Head



Auger Thread



Speed (MPH) Prior To Road Work	SIGN SPACING, FT.		Must be Approved by an Engineer				
	Non-Divided Highways	Divided Highways	BUFFER SPACE, FT.	TAPER LENGTH, FT.	CHANNELIZING SPACING, FT.		
	Length	Shoulder (10 ft. Width)	Lane (12 ft. Width)	Through Taper	Through Buffer/Work Area		
0-35	200	200	250	70	245	35	50
40-45	350	500	360	150	540	40	80
50-55	500	1000	495	185	660	50	100
60-70	SA-1000, SB-1500, SC-2640		730	235	840	60	120
	Urban Low Speed - 100 FT						

APPROVED/ACCEPTED BY:
ENGINEER, OWNER, or PRIME CONTRACTOR
 Check for Notice to Proceed.

Signature: _____

Company: _____

Road Runner Safety Services, Inc.

Date: 8/9/2023 Project: BLN01b-F10 N Morton St - TCP1 :
Traffic Control Suggestion For: ATLANTIC ENGINEERING (AEG) :
By: Road Runner Safety Services, Inc. : Nathan

Comments:
Drawing not to scale. Traffic control plan must be approved by an engineer. This is a suggestion only. Road Runners Safety Services, Inc. has no liability for this suggested traffic control plan. Actual placement and spacing of all traffic control devices will depend on field conditions and must conform to MUTCD standards.



Work Areas will move along indicated lines.
Two lane streets will use Flagger setup.
On streets with parking, work area located in parking stalls.

SIDEWALK CLOSED AHEAD
SIGNS SHOULD BE PLACED
AT NEAREST CORNER

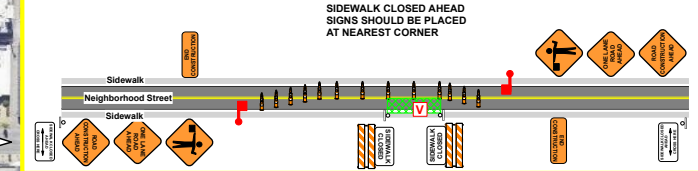
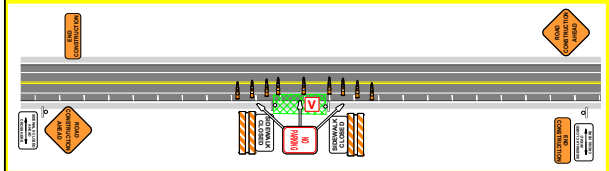

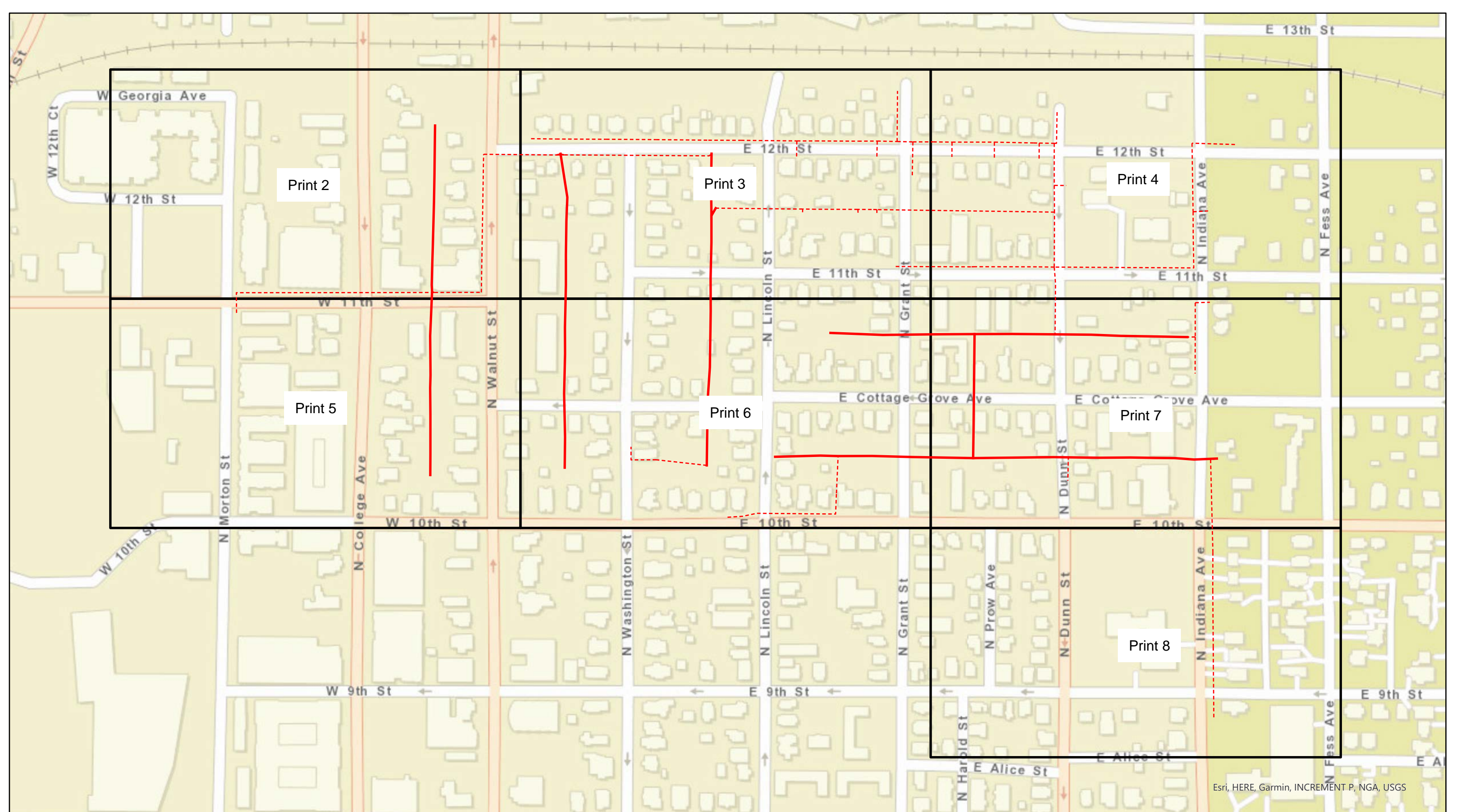

Esri, HERE, Garmin, INCREMENT P, NGA, USGS



Legend BLN01b-F09_N Lincoln St

- Overhead Strand
- - - Conduit
- Grids

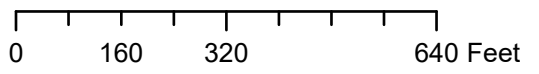

City of Bloomington, IN Permit:
Design View

INI	BY	DATE	DESCRIPTION



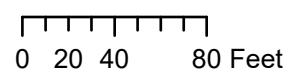
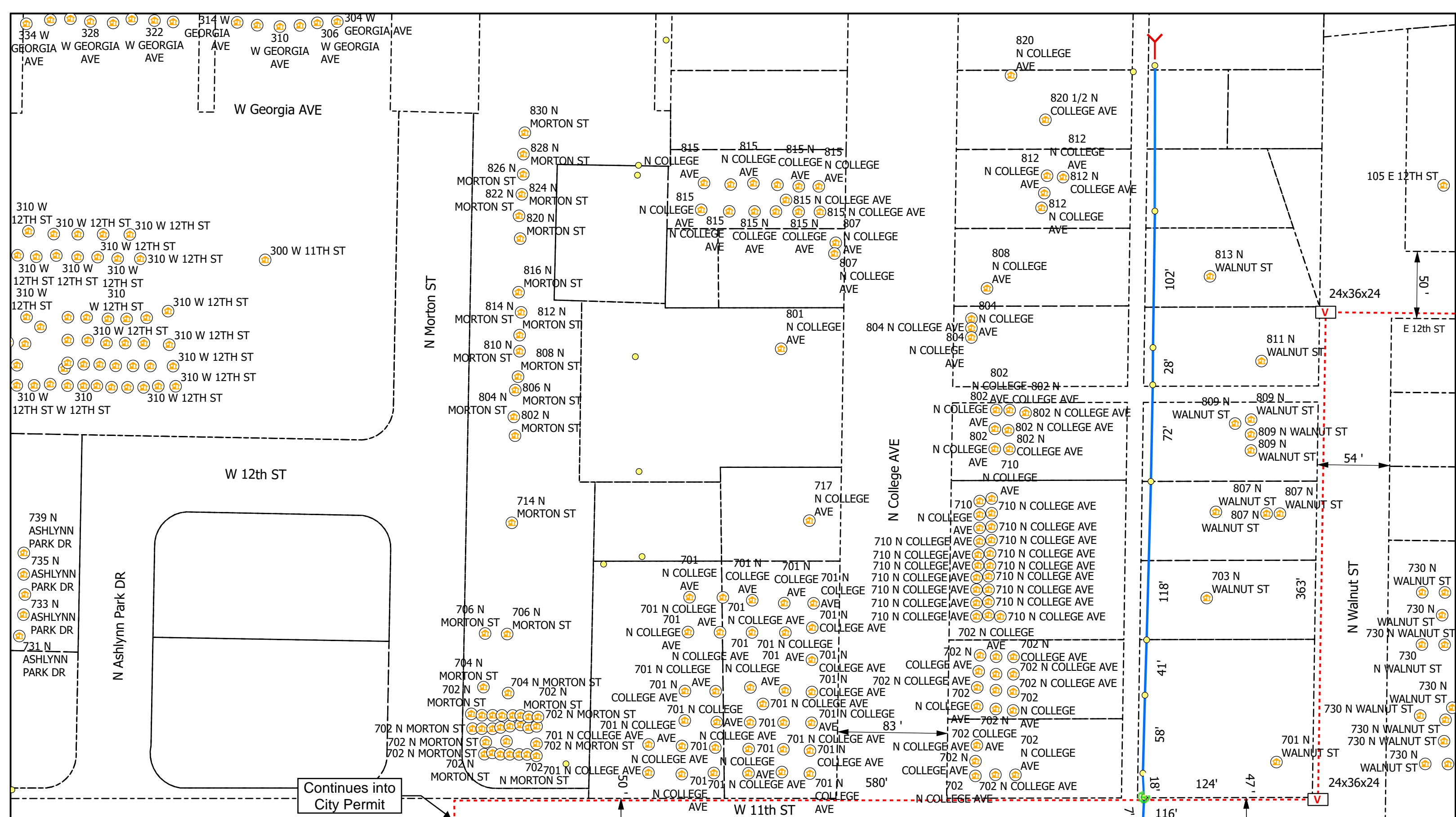

Legend

- Poles
- Ⓡ Risers
- ⬆ Sidewalk
- V Vaults
- Overhead Strand
- - - Conduit
- 🏠 Address
- Y Anchor
- Bloomington_Parcels
- Grids

All Flowerpots 12" DIA



City of Bloomington, IN Permit:
Design View

INI	BY	DATE	DESCRIPTION



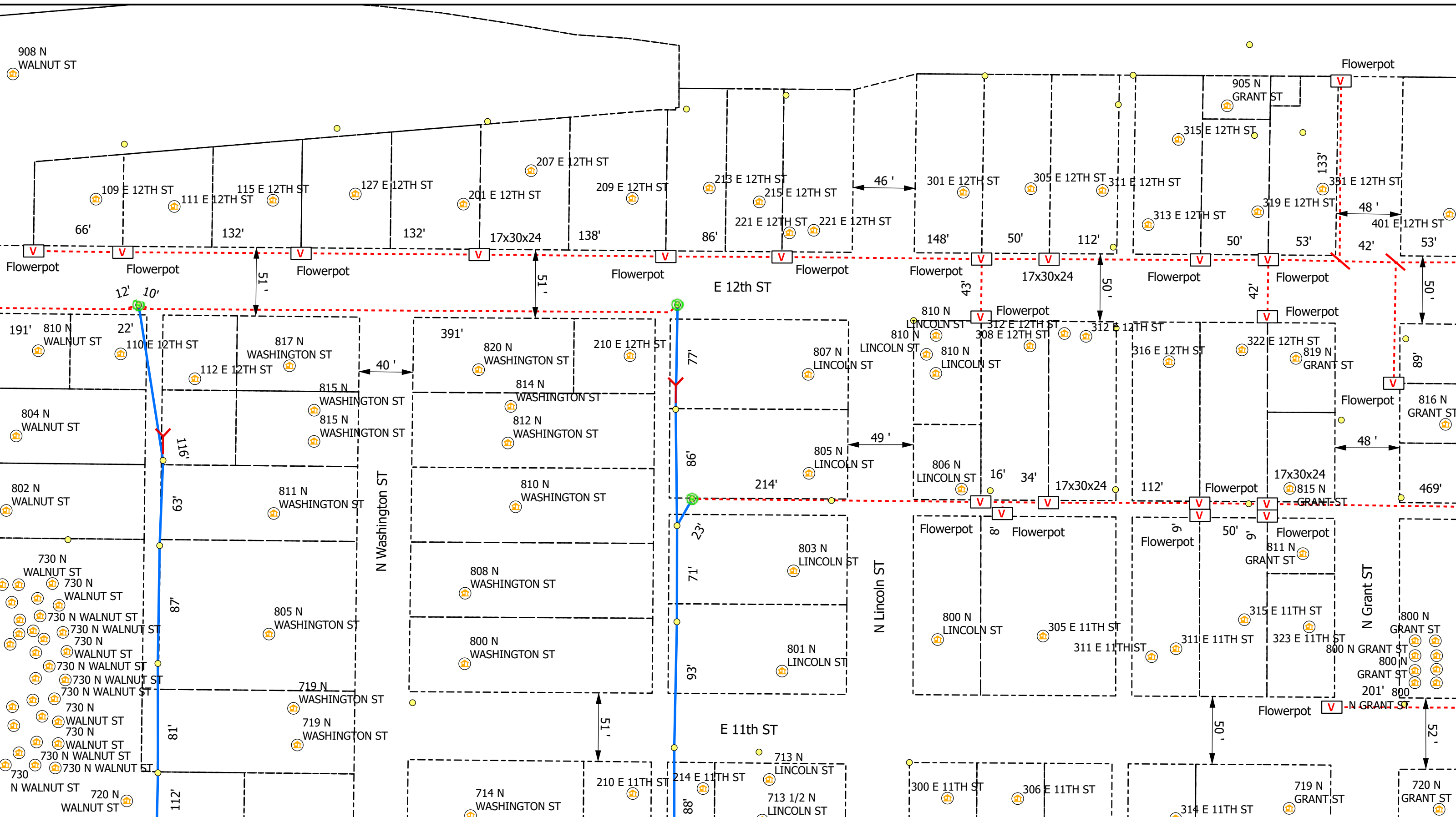

0 20 40 80 Feet

Legend

- Poles
- ⊕ Risers
- ⏏ Sidewalk
- V Vaults
- Ⓜ Address
- Bloomington_Parcels
- Overhead Strand
- - - Conduit
- Y Anchor
- Grids

All Flowerpots 12" DIA

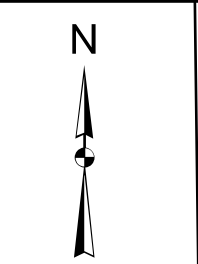

City of Bloomington, IN Permit:
Design View

INI	BY	DATE	DESCRIPTION

Print 3 of 8

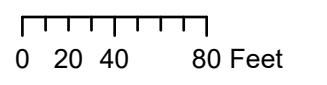
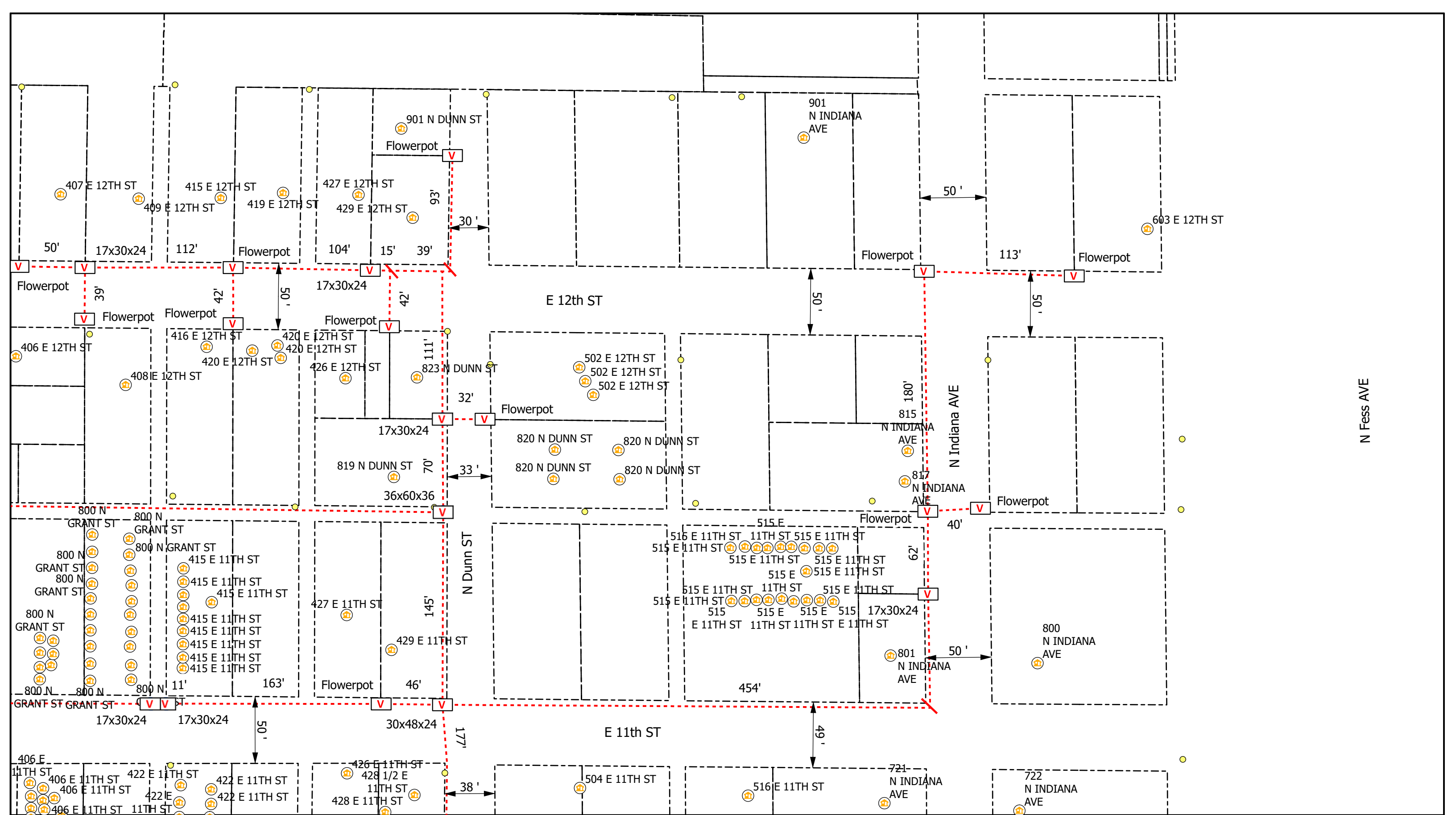

Legend

- Poles
- ⊕ Risers
- ⏏ Sidewalk
- V Vaults
- Ⓜ Address
- Bloomington_Parcels
- Overhead Strand
- Conduit
- Y Anchor
- Grids

All Flowerpots 12" DIA



City of Bloomington, IN Permit:
Design View

INI	BY	DATE	DESCRIPTION



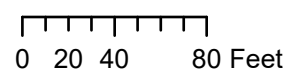
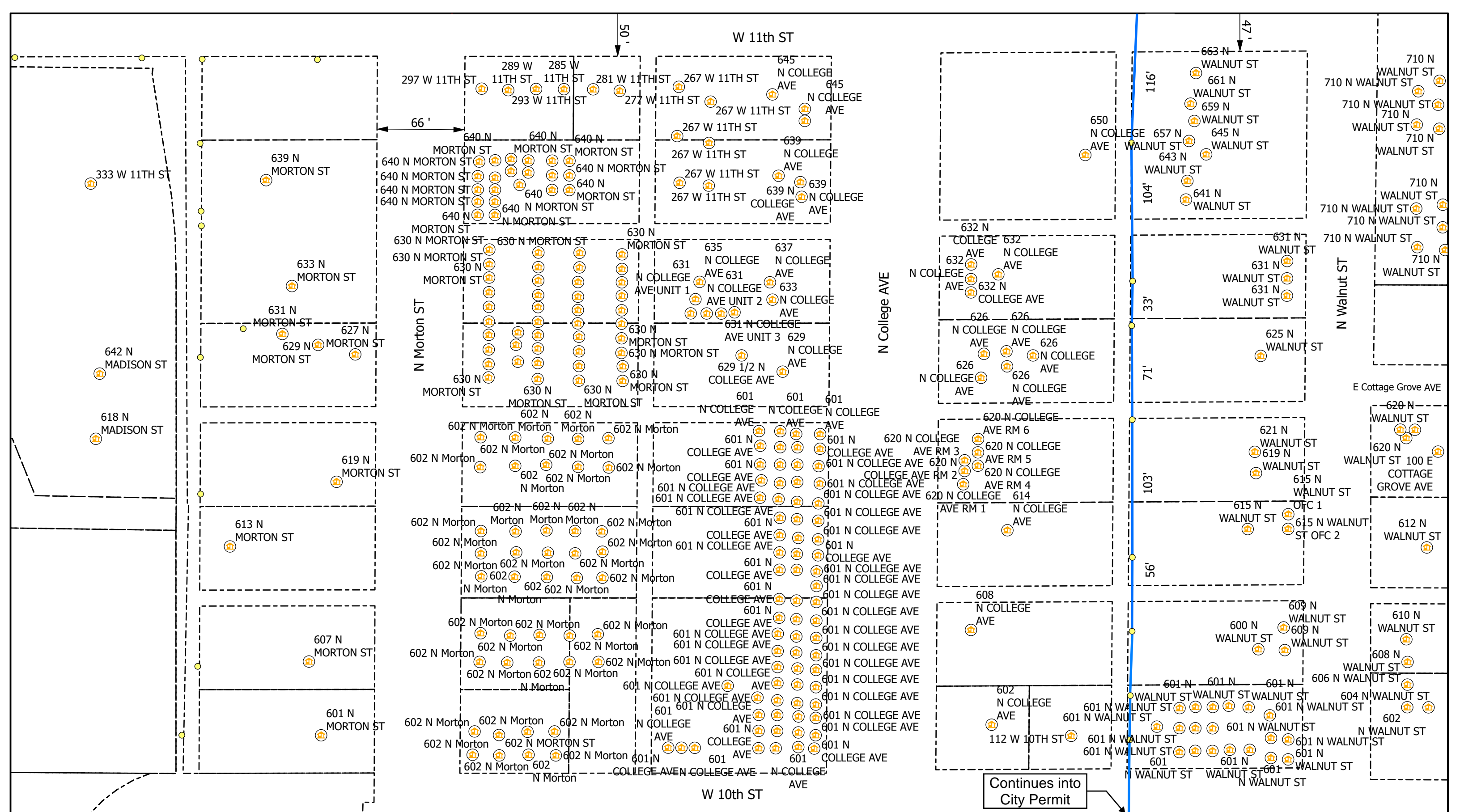

Legend

- Poles
- V Vaults
- Overhead Strand
- Conduit
- Ⓡ Risers
- Ⓜ Address
- Y Anchor
- ↖ Sidewalk
- Bloomington_Parcels
- Grids

All Flowerpots 12" DIA



City of Bloomington, IN Permit:
Design View

INI	BY	DATE	DESCRIPTION



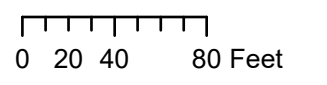
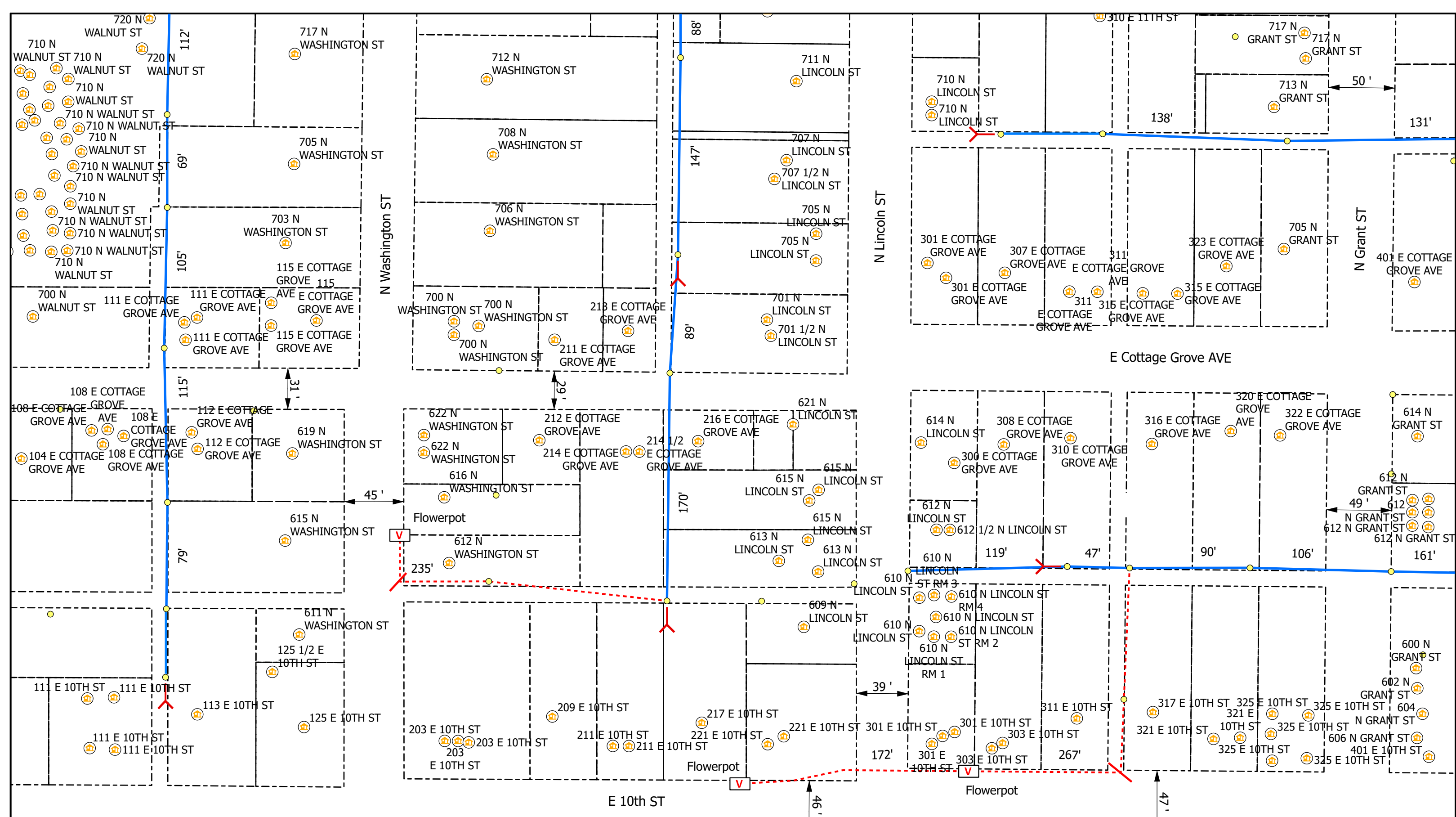

Legend

- Poles
- Ⓡ Risers
- ⏏ Sidewalk
- V Vaults
- 🏠 Address
- Bloomington_Parcels
- Overhead Strand
- Conduit
- Y Anchor
- Grids

All Flowerpots 12" DIA



City of Bloomington, IN Permit:
Design View

INI	BY	DATE	DESCRIPTION



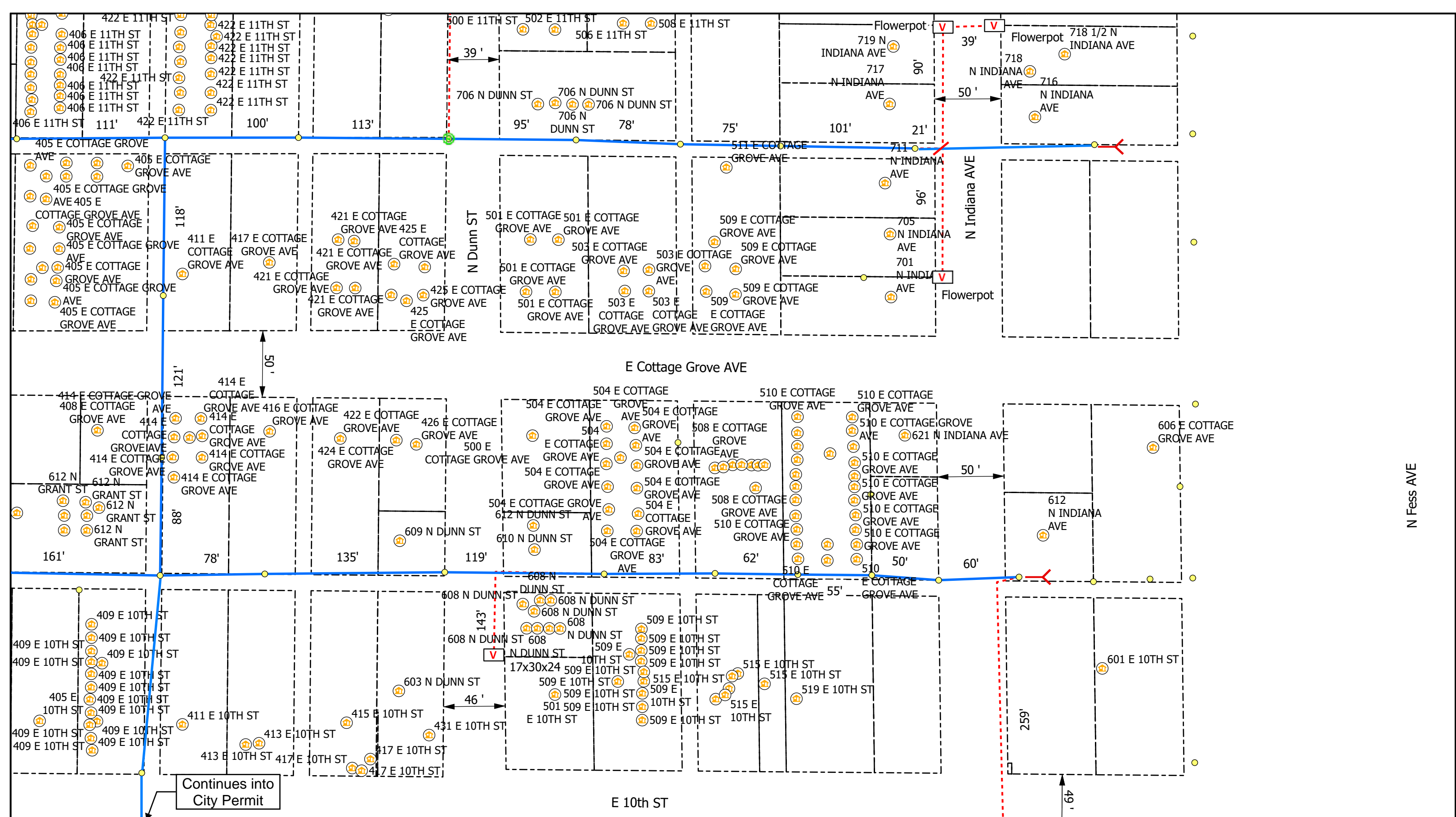

Continues into City Permit

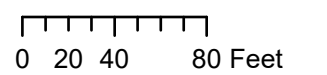

Legend

- Poles
- Vaults
- Overhead Strand
- Conduit
- Risers
- Address
- Anchor
- Sidewalk
- Bloomington_Parcels
- Grids

All Flowerpots 12" DIA



City of Bloomington, IN Permit:
Design View

INI	BY	DATE	DESCRIPTION



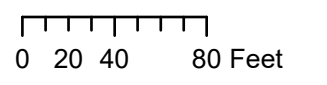
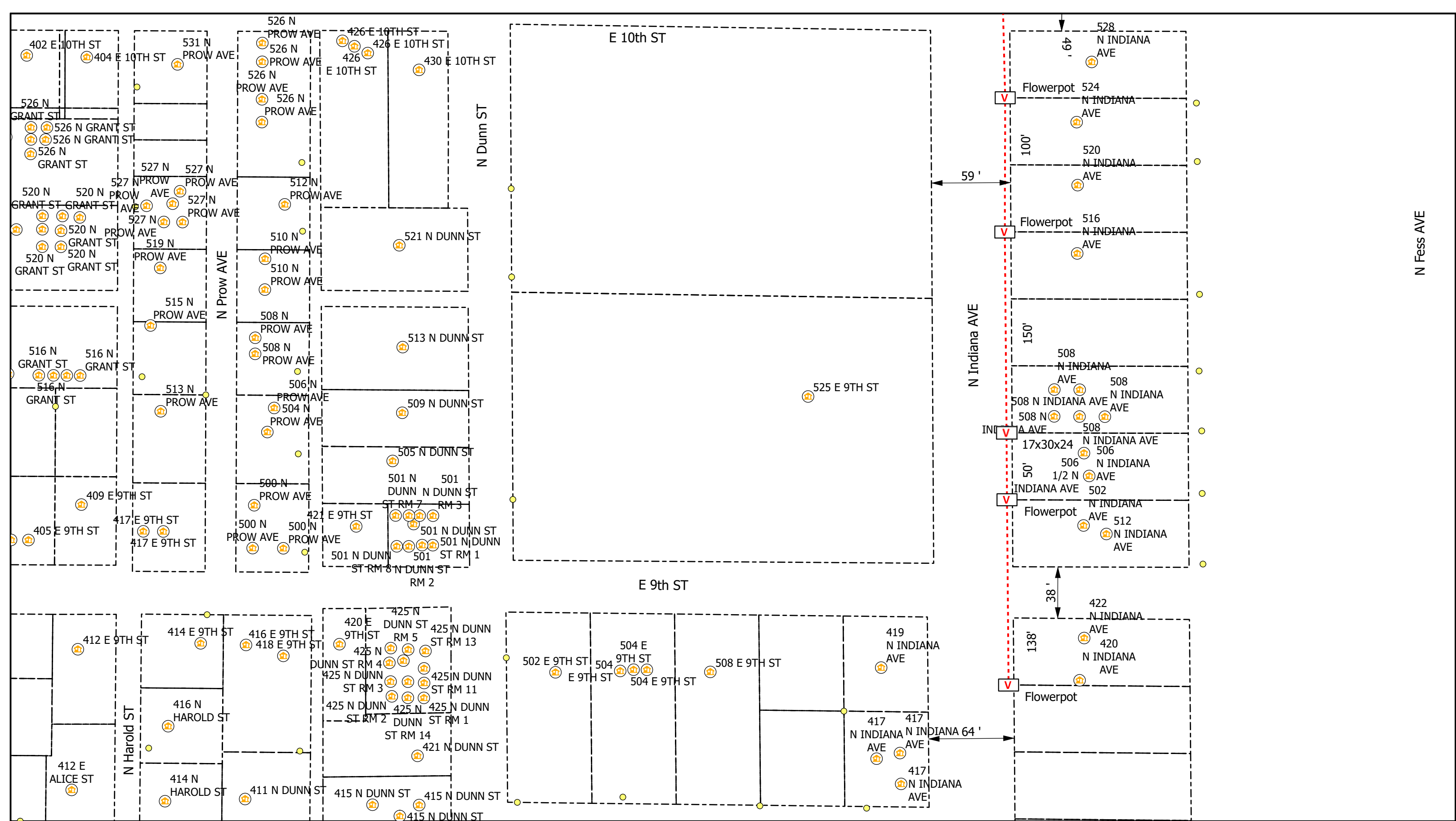

Legend

- Poles
- V Vaults
- Overhead Strand
- - - Conduit
- Ⓡ Risers
- 🏠 Address
- Y Anchor
- ↖ Sidewalk
- Bloomington_Parcels
- Grids

All Flowerpots 12" DIA



City of Bloomington, IN Permit:
Design View

INI	BY	DATE	DESCRIPTION



Carlton® PV-Mold® Nonmetallic Pole Riser System

Carlton PV-Mold is a nonmetallic pole riser system designed to protect communications power cable installed on poles.

Features:

- Meets or exceeds requirements outlined in the National Electric Safety Code (NESC).
- Designed in accordance with NEMA TC-19 specifications.
- Ultraviolet, cold temperature and corrosive atmosphere resistant.
- Schedule 40 wall meets Schedule 80 PVC conduit impact requirements per NEMA TC-19.
- No grounding required.
- Belled end fits over each added section or conduit.
- Flame retardant.
- Requires no maintenance.
- PV-Mold acts as an insulator against electrical shock.
- Interchangeable parts and accessories to match the needs of specific requirements.



Steel U-Guard requires grounding strapping and does not have belled ends.



PV-Mold has belled ends, flanged design and does not require grounding.

Flanged Overall Length 10 Feet, Including Bell

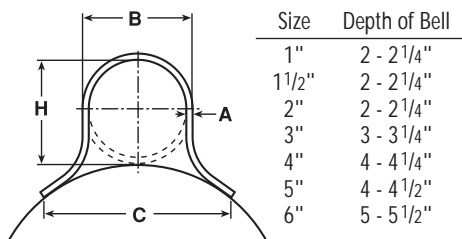

Slots are 1/2" from side to side, and allow for expansion and contraction.

Slot Dimensions: for sizes 2" through 6" are 5/16" wide, 3/4" long.

Slot Dimensions: for 1" and 1 1/2" are 3/16" wide, 3/4" long.

Slot Spacing: 18" from center, beginning 6" from end.

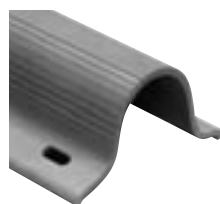

Standard Duty

Part No.	Size	Std. Ctn. Qty.	Std. Ctn. Wt. (lbs.)	Dimensions				Actual Impact @ 0°C 20 Pound Top
				A	B	C	H	
59208N	1"	294	1059	0.100"	1 5/8"	2 3/8"	1 5/8"	40 Ft.-Lbs.
59211N	2"	136	726	0.100"	2 3/8"	4 1/2"	2 3/8"	100 Ft.-Lbs.
59211X (5' length)	2"	136	363	0.100"	2 3/8"	4 1/2"	2 3/8"	100 Ft.-Lbs.
59213N	3"	66	761	0.150"	3 1/2"	6"	3 1/2"	110 Ft.-Lbs.
59213X (5' length)	3"	66	381	0.150"	3 1/2"	6"	3 1/2"	100 Ft.-Lbs.
59215N	4"	65	910	0.150"	4 1/2"	6 1/2"	4 1/2"	110 Ft.-Lbs.
59216N	5"	30	515	0.150"	5 1/2"	7 1/2"	5 1/2"	110 Ft.-Lbs.

Heavy Duty Schedule 40

59010N	1 1/2"	200	1142	0.145"	1 29/32"	3 1/2"	1 29/32"	100 Ft.-Lbs.
59011N	2"	136	1214	0.154"	2 3/8"	4 1/2"	2 3/8"	150 Ft.-Lbs.
59013N	3"	66	937	0.216"	3 1/2"	6"	3 9/32"	150 Ft.-Lbs.
59015N	4"	65	1621	0.237"	4 1/2"	6 1/2"	4 1/2"	260 Ft.-Lbs.
59015X (5' length)	4"	65	707	0.237"	4 1/2"	6 1/2"	4 1/2"	260 Ft.-Lbs.
59016N	5"	30	870	0.258"	5 1/2"	7 1/2"	5 1/2"	260 Ft.-Lbs.
59017N	6"	30	1160	0.280"	6 5/8"	8 3/4"	6 5/8"	260 Ft.-Lbs.

Extra Heavy Duty Schedule 80

59411N	2"	136	1549	0.218"	2 3/8"	4 1/2"	2 3/8"	300 Ft.-Lbs.
59413N	3"	66	1495	0.030"	3 1/2"	6"	3 1/2"	525 Ft.-Lbs.

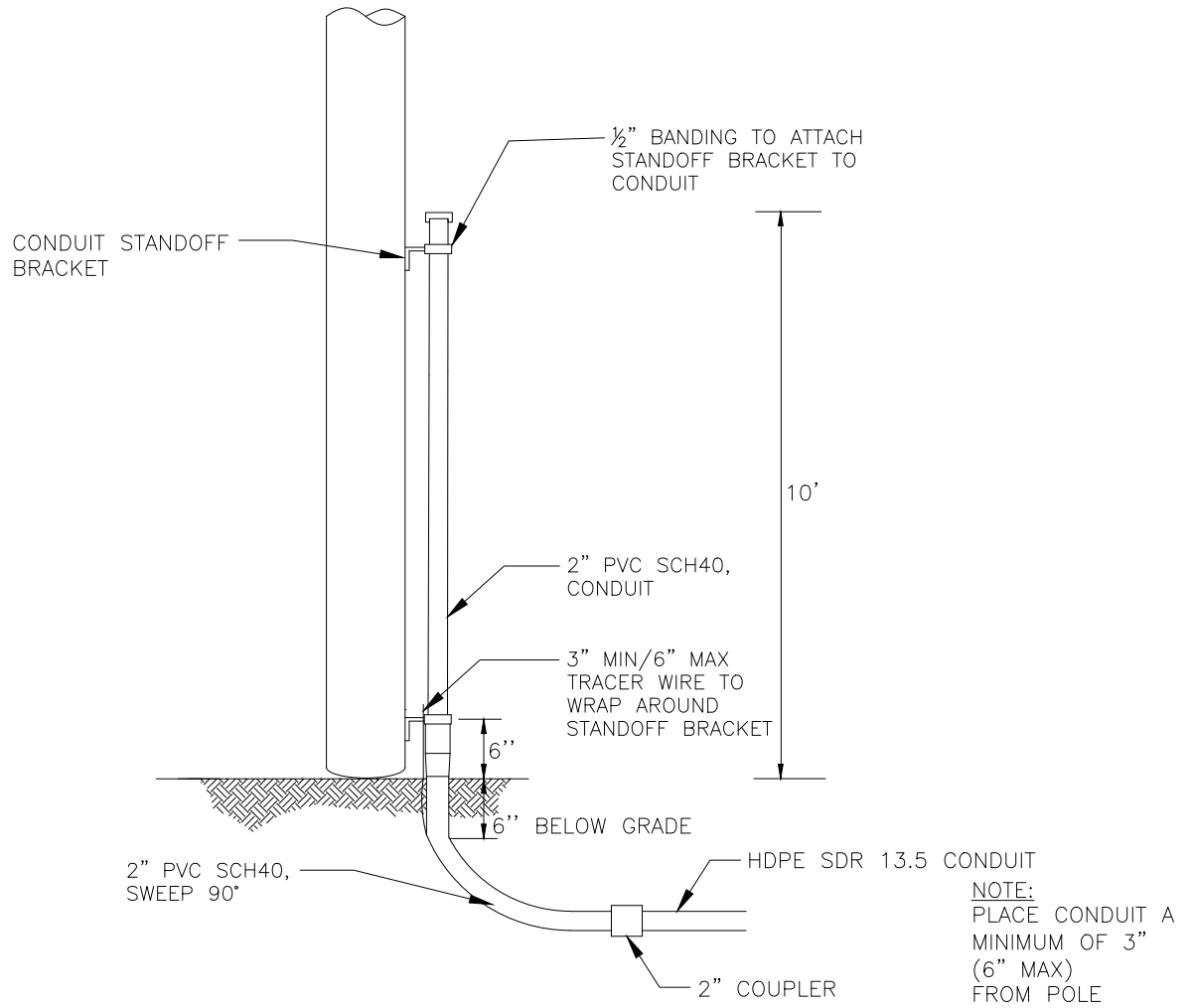

DESCRIPTION

QTY

MANUFACTURER
(PREFERRED)

PART #

SCREW, LAG, 1/2" x 4-1/2"	10		
HDPE SDR 13.5 CONDUIT, VARIOUS SIZES	N/A		
2" PVC SCH40, RISER PIPE	1		
#12 TRACER WIRE	N/A		
2" PVC SCH40, SWEEP, 90 DEG	1		
CONDUIT STANDOFF BRACKET	VARIES		
CONDUIT STRAP KIT	VARIES		
2" COUPLER	1		



TYPICAL RISER
CONDUIT
WOOD POLE

(R2-W)

CONCEPTUAL SIDE VIEW

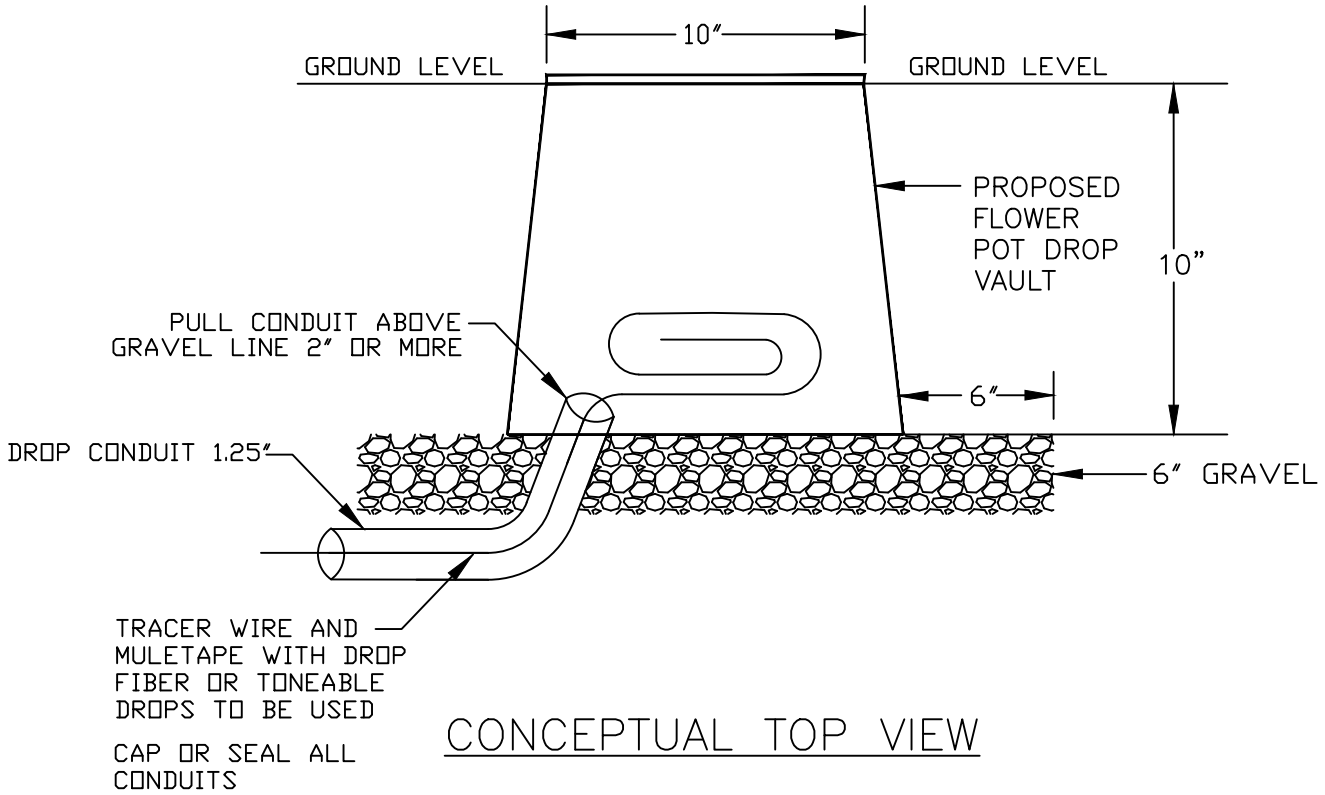

CONCEPTUAL TOP VIEW

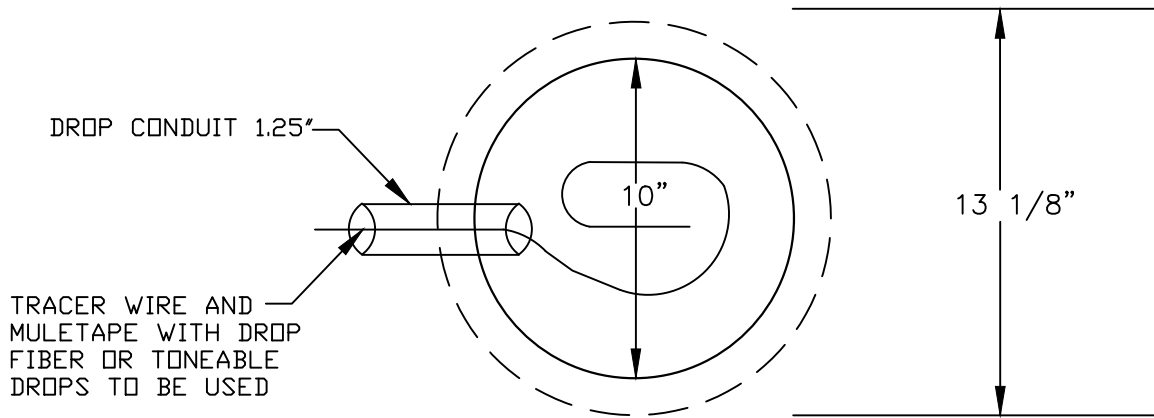

FLOWER POT

30"x48" PC UNIT, 2PC TIER 15/22
 18", 24", and 36" HEIGHT



AMERICAN POLYMER COMPANY

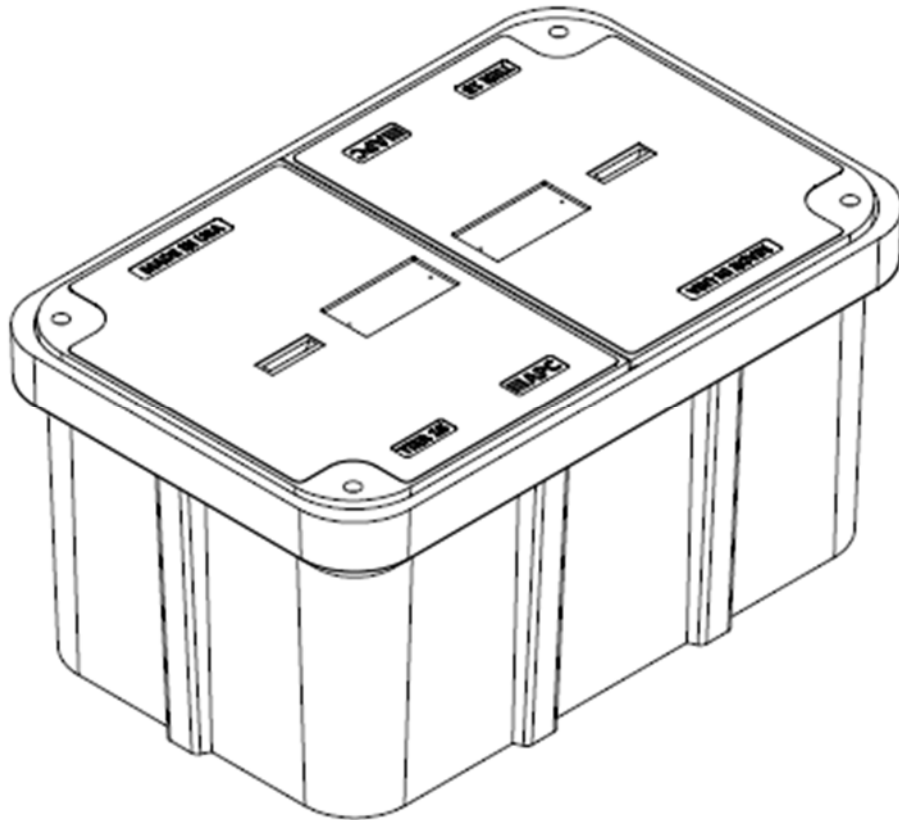

Description	Nominal Size	ANSI Tier	Part Number	Estimated Weight
PC Unit – TIER 15	30"x48"x18"	Tier 15	P304818HU15...	460 lbs.
PC Unit – TIER 22	30"x48"x18"	Tier 22	P304818HU22...	525 lbs.
PC Unit – TIER 15	30"x48"x24"	Tier 15	P304824HU15...	510 lbs.
PC Unit – TIER 22	30"x48"x24"	Tier 22	P304824HU22...	575 lbs.
PC Unit – TIER 15	30"x48"x36"	Tier 15	P304836HU15...	615 lbs.
PC Unit – TIER 22	30"x48"x36"	Tier 22	P304836HU22...	680 lbs.



30"x48" PC UNIT, 2PC TIER 15/22

18", 24", and 36" HEIGHT



AMERICAN POLYMER COMPANY

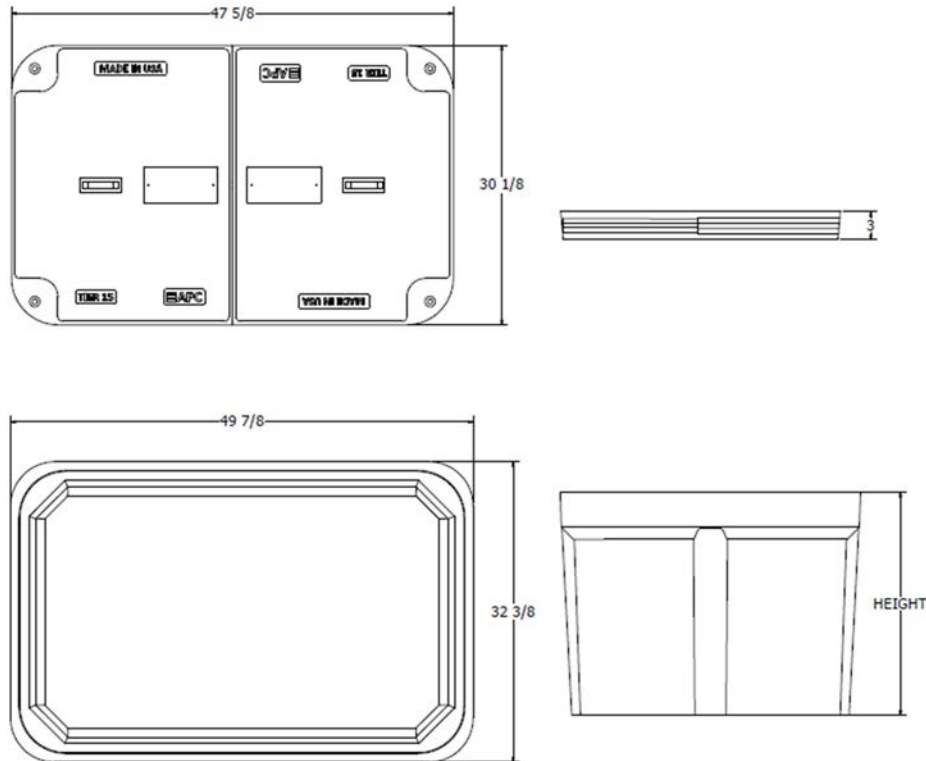

Components	Nominal Size	ANSI Tier	Part Number	Estimated Weight
Replacement Box	30"x48"x18"	Tier 22	P304818B22	185 lbs.
Replacement Box	30"x48"x24"	Tier 22	P304824B22	235 lbs.
Replacement Box	30"x48"x36"	Tier 22	P304836B22	340 lbs.
Replacement Lids - T15	30"x48" (half)	Tier 15	Various	150 lbs.
Replacement Lids - T22	30"x48" (half)	Tier 22	Various	170 lbs.

Bolt options

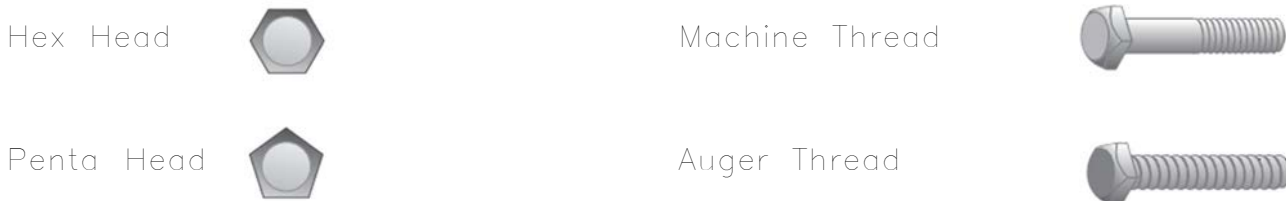

24"x36" PC UNIT, TIER 15/22
 18", 24", 30", and 36" HEIGHT



AMERICAN POLYMER COMPANY

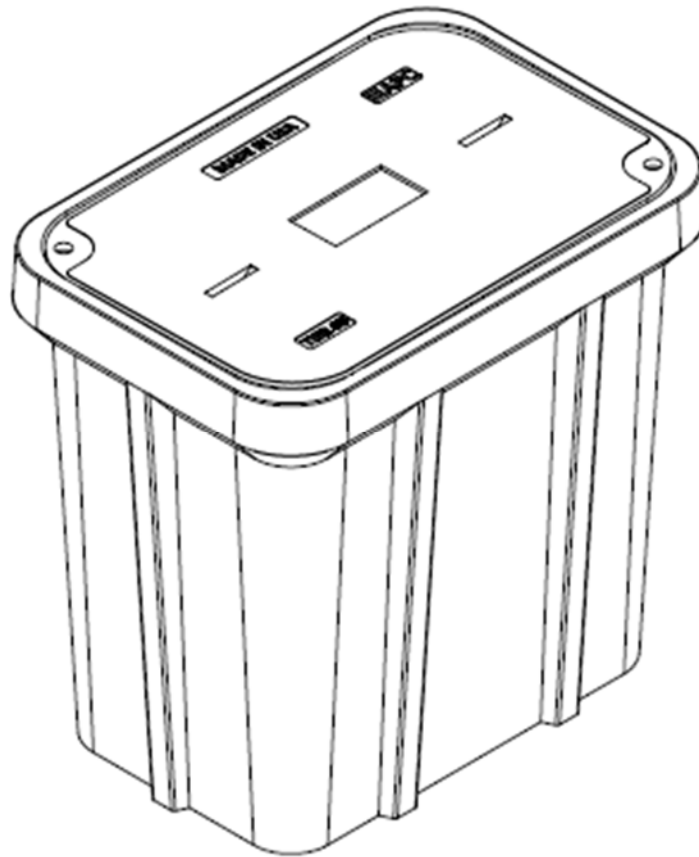

Description	Nominal Size	ANSI Tier	Part Number	Estimated Weight
PC Unit – TIER 15	24x36"x18"	Tier 15	P243618U15...	335 lbs.
PC Unit – TIER 22	24x36"x18"	Tier 22	P243618U22...	355 lbs.
PC Unit – TIER 15	24x36"x24"	Tier 15	P243624U15...	365 lbs.
PC Unit – TIER 22	24x36"x24"	Tier 22	P243624U22...	385 lbs.
PC Unit – TIER 15	24x36"x30"	Tier 15	P243630U15...	395 lbs.
PC Unit – TIER 22	24x36"x30"	Tier 22	P243630U22...	415 lbs.
PC Unit – TIER 15	24x36"x36"	Tier 15	P243636U15...	425 lbs.
PC Unit – TIER 22	24x36"x36"	Tier 22	P243636U22...	445 lbs.



24"x36" PC UNIT, TIER 15/22

18", 24", 30", and 36" HEIGHT



AMERICAN POLYMER COMPANY

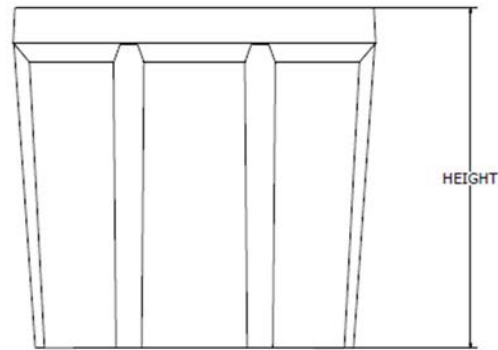
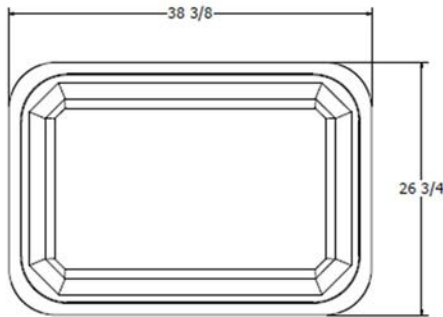
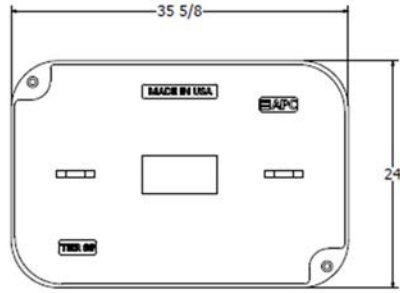

Components	Nominal Size	ANSI Tier	Part Number	Estimated Weight
Replacement Box	24"x36"x18"	Tier 22	P243618B22	165 lbs.
Replacement Box	24"x36"x24"	Tier 22	P243624B22	195 lbs.
Replacement Box	24"x36"x30"	Tier 22	P243630B22	225 lbs.
Replacement Box	24"x36"x36"	Tier 22	P243636B22	255 lbs.
Replacement Lids - T15	24"x36"	Tier 15	Various	170 lbs.
Replacement Lids - T22	24"x36"	Tier 22	Various	190 lbs.

Bolt options

Hex Head



Machine Thread



Penta Head



Auger Thread



17"x30" PC UNIT, TIER 15/22

12", 18", 24", and 30" HEIGHT



AMERICAN POLYMER COMPANY

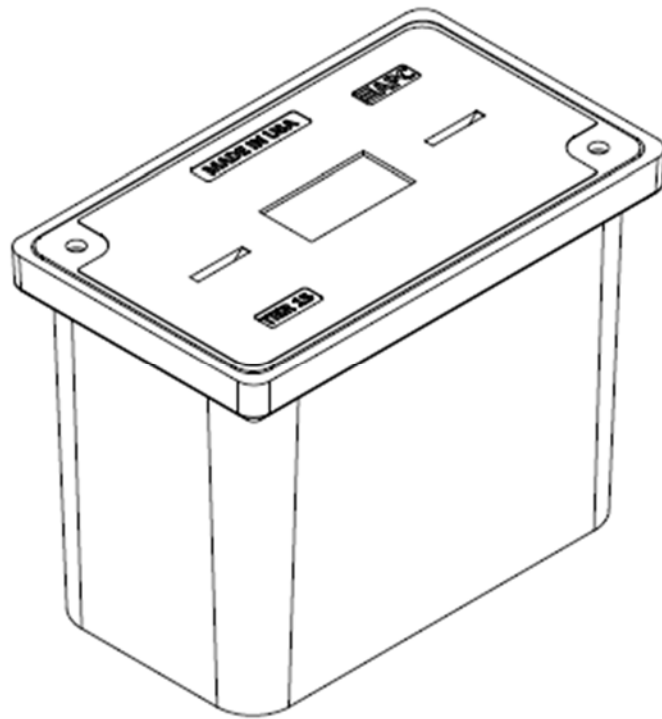

Description	Nominal Size	ANSI Tier	Part Number	Estimated Weight
PC Unit - TIER 15	17"x30"x12"	Tier 15	P173012U15...	138 lbs.
PC Unit - TIER 22	17"x30"x12"	Tier 22	P173012U22...	147 lbs.
PC Unit - TIER 15	17"x30"x18"	Tier 15	P173018U15...	172 lbs.
PC Unit - TIER 22	17"x30"x18"	Tier 22	P173018U22...	181 lbs.
PC Unit - TIER 15	17"x30"x24"	Tier 15	P173024U15...	192 lbs.
PC Unit - TIER 22	17"x30"x24"	Tier 22	P173024U22...	201 lbs.
PC Unit - TIER 15	17"x30"x30"	Tier 15	P173030U15...	217 lbs.
PC Unit - TIER 22	17"x30"x30"	Tier 22	P173030U22...	226 lbs.



17"x30" PC UNIT, TIER 15/22

12", 18", 24", and 30" HEIGHT



AMERICAN POLYMER COMPANY

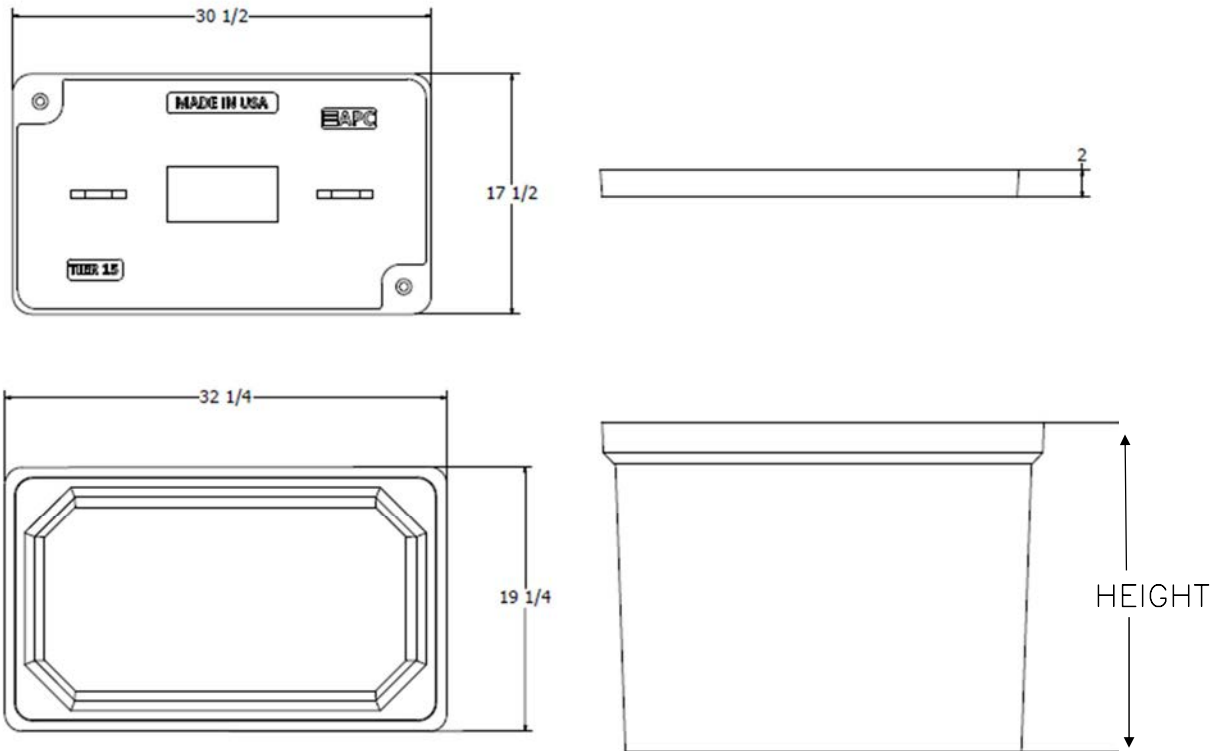

Components	Nominal Size	ANSI Tier	Part Number	Estimated Weight
Replacement Box	17"x30"x12"	Tier 22	P173012B22	66 lbs.
Replacement Box	17"x30"x18"	Tier 22	P173018B22	100 lbs.
Replacement Box	17"x30"x24"	Tier 22	P173024B22	120 lbs.
Replacement Box	17"x30"x30"	Tier 22	P173030B22	145 lbs.
Replacement Lids - T15	17"x30"	Tier 15	Various	72 lbs.
Replacement Lids - T22	17"x30"	Tier 22	Various	81 lbs.

Bolt options



Machine Thread



Auger Thread



33"x60" PC UNIT, 2PC TIER 15/22
36" HEIGHT



AMERICAN POLYMER COMPANY

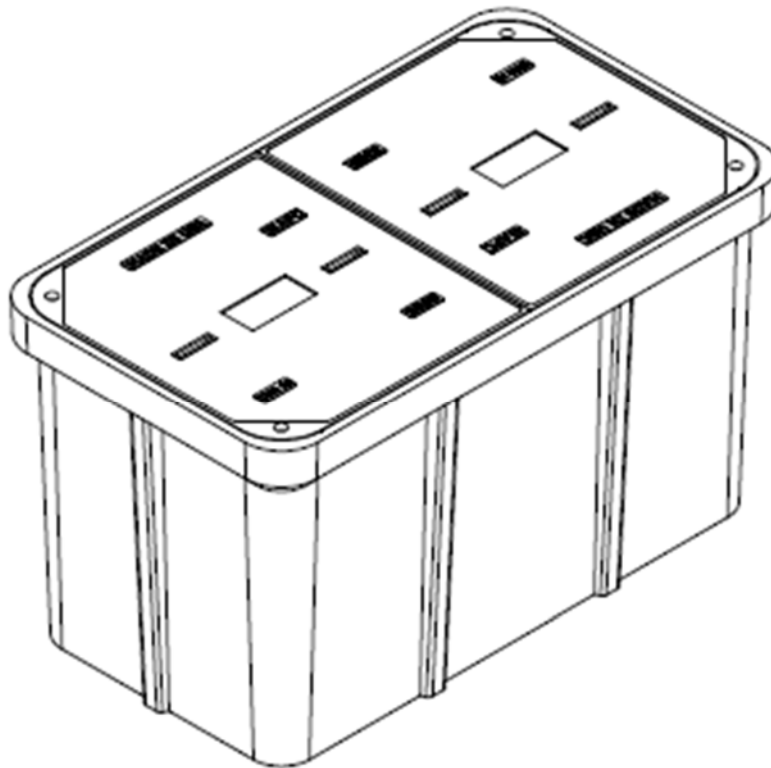

Description	Nominal Size	ANSI Tier	Part Number	Estimated Weight
PC Unit - TIER 15	33"x60"x36"	Tier 15	P336036U15...	930 lbs.
PC Unit - TIER 22	33"x60"x36"	Tier 22	P336036U22...	1030 lbs.



33"x60" PC UNIT, 2PC TIER 15/22

36" HEIGHT



AMERICAN POLYMER COMPANY

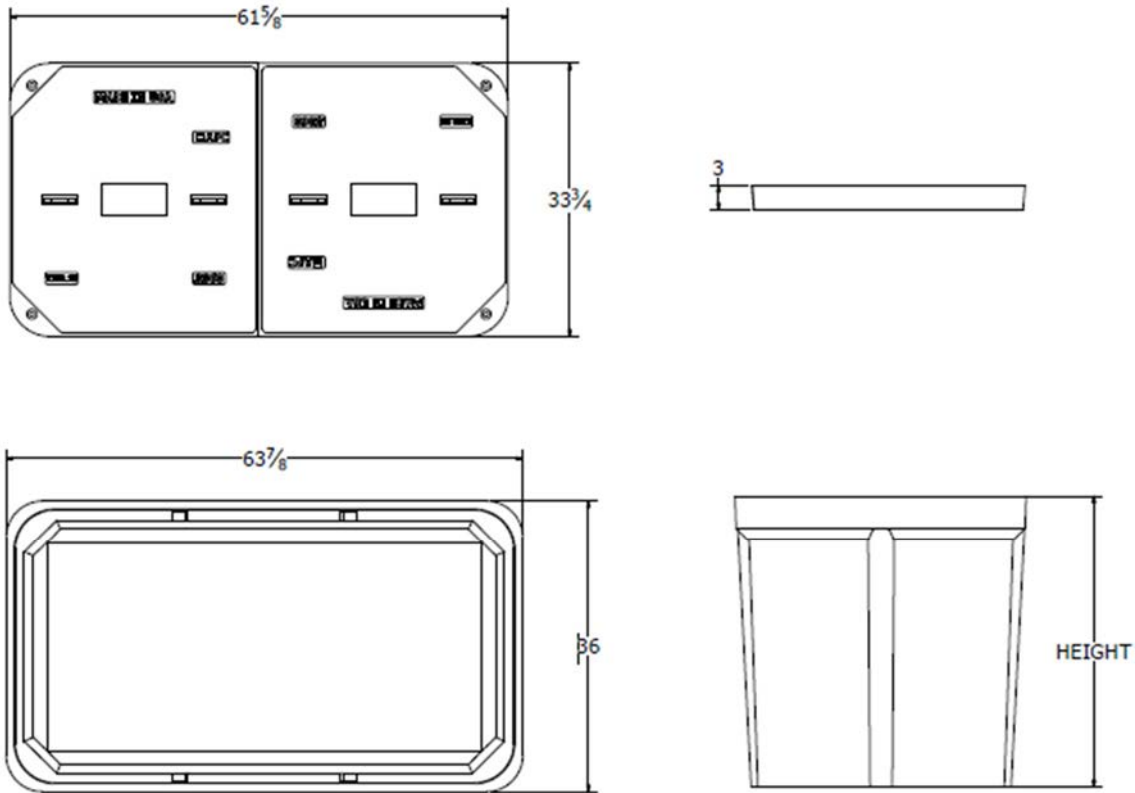

Components	Nominal Size	ANSI Tier	Part Number	Estimated Weight
Replacement Box	33"x60"x36"	Tier 22	P336036B22	530 lbs.
Replacement Lids - T15	33"x60" (half)	Tier 15	Various	200 lbs.
Replacement Lids - T22	33"x60" (half)	Tier 22	Various	250 lbs.

Bolt options

Hex Head



Machine Thread



Penta Head



Auger Thread



Speed (MPH) Prior To Road Work	SIGN SPACING, FT.		MUTCD Must be Approved by an Engineer				
	Non-Divided Highways	Divided Highways	BUFFER SPACE, FT.	TAPER LENGTH, FT.	CHANNELIZING SPACING, FT.		
	Length	Shoulder (10 ft. Width)	Lane (12 ft. Width)	Through Taper	Through Buffer/Work Area		
0-35	200	200	250	70	245	35	50
40-45	350	500	360	150	540	40	80
50-55	500	1000	495	185	660	50	100
60-70	SA-1000, SB-1500, SC-2640		730	235	840	60	120
Urban Low Speed - 100 FT							

APPROVED/ACCEPTED BY:
ENGINEER, OWNER, or PRIME CONTRACTOR
 Check for Notice to Proceed.

Signature: _____

Company: _____

Date: 11/27/2023 **Project:** BLN01b-F09_N Lincoln St TCP ;
Traffic Control Suggestion For: ATLANTIC ENGINEERING (AEG) ;
By: Road Runner Safety Services, Inc. : Nathan

Comments:
 Drawing not to scale. Traffic control plan must be approved by an engineer. This is a suggestion only. Road Runners Safety Services, Inc. has no liability for this suggested traffic control plan. Actual placement and spacing of all traffic control devices will depend on field conditions and must conform to MUTCD standards.



- Legend**
- ADA Barricade
 - Channelizer
 - Conduit
 - Flagger (Person)
 - Overhead Strand
 - Sign
 - Vault
 - Work Area

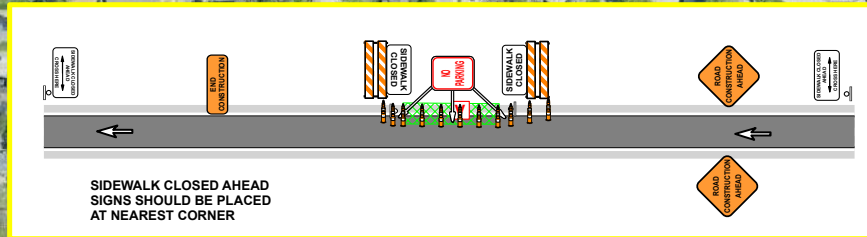
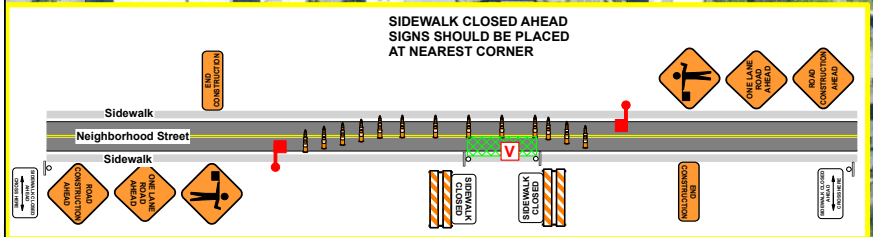



Board of Public Works Claim Register

Invoice Date Range 05/11/24 - 05/24/24

Vendor	Invoice Description	Contract #	Payment Date	Invoice Amount
Fund 101 - General Fund (S0101)				
Department 01 - Animal Shelter				
Program 010000 - Main				
Account 43430 - Animal Adoption Fees				
Diana Hanson	01-refund adoption fee-4/29/24		05/24/2024	100.00
Summer Miller	01-refund adoption fee-4/30/24		05/24/2024	100.00
Account 43430 - Animal Adoption Fees Totals			Invoice 2 Transactions	<u>\$200.00</u>
Account 52210 - Institutional Supplies				
8541 - Amazon.com Sales, INC (Amazon.com Services LLC)	01-Dog Leashes (8) & Yard Flag		05/24/2024	77.49
4586 - Hill's Pet Nutrition Sales, INC	01-refund for undelivered product-puppy food		05/24/2024	(41.34)
4586 - Hill's Pet Nutrition Sales, INC	01-Dog, puppy, cat & kitten food	BC 2024-026	05/24/2024	351.83
4586 - Hill's Pet Nutrition Sales, INC	01-Prescription Vet Pet Food	BC 2024-026	05/24/2024	163.04
4586 - Hill's Pet Nutrition Sales, INC	01-Dog & Kitten Food	BC 2024-026	05/24/2024	212.60
4574 - John Deere Financial f.s.b. (Rural King)	01-litter-50 40lb bags pellet bedding, paper towels		05/24/2024	269.46
4549 - Kroger Limited Partnership I	01-cat milk and rabbit food		05/24/2024	21.52
4633 - Midwest Veterinary Supply, INC	01-bottles for medication		05/24/2024	55.80
4633 - Midwest Veterinary Supply, INC	01-vinyl exam gloves, isolation gowns		05/24/2024	76.13
4633 - Midwest Veterinary Supply, INC	01-vinyl exam gloves, lactated ringers		05/24/2024	106.07
4633 - Midwest Veterinary Supply, INC	01-Medications, Vaccines, toothbrush, bottles		05/24/2024	1,452.89
4666 - Zoetis, INC	01-Feline and Canine vaccines		05/24/2024	1,593.00
Account 52210 - Institutional Supplies Totals			Invoice 12 Transactions	<u>\$4,338.49</u>
Account 52340 - Other Repairs and Maintenance				



Board of Public Works Claim Register

Invoice Date Range 05/11/24 - 05/24/24

313 - Fastenal Company	01-5 Replacement Soap Dispensers		05/24/2024	205.00
313 - Fastenal Company	01-Replacement Soap Dispensers & hand sanitizer		05/24/2024	362.66
313 - Fastenal Company	01-Towels & Batteries		05/24/2024	74.99
Account 52340 - Other Repairs and Maintenance Totals			Invoice 3 Transactions	<u>\$642.65</u>
Account 52420 - Other Supplies				
3560 - First Financial Bank / Credit Cards	01-Party City-balloons for volunteer appreciation week		05/24/2024	20.00
3560 - First Financial Bank / Credit Cards	01-Sams Club-flowers for volunteer appreciation week		05/24/2024	30.24
3560 - First Financial Bank / Credit Cards	01-Sams Club-snacks for volunteer appreciation week-4/18/24		05/24/2024	127.75
Account 52420 - Other Supplies Totals			Invoice 3 Transactions	<u>\$177.99</u>
Account 52430 - Uniforms and Tools				
4832 - Animal Care Equipment & Services, LLC	01-Safety Gloves for animal handling		05/24/2024	508.92
Account 52430 - Uniforms and Tools Totals			Invoice 1 Transactions	<u>\$508.92</u>
Account 53130 - Medical				
3376 - Bloomington Pets Alive, INC	01-Spay/Neuter Surgeries - 4/16-4/30/24		05/24/2024	4,764.63
Account 53130 - Medical Totals			Invoice 1 Transactions	<u>\$4,764.63</u>
Account 53160 - Instruction				
3560 - First Financial Bank / Credit Cards	01-Unmanned Arial Vehicle Pilot Training - Kat Ennis		05/24/2024	159.00
Account 53160 - Instruction Totals			Invoice 1 Transactions	<u>\$159.00</u>
Account 53610 - Building Repairs				
321 - Harrell Fish, INC (HFI)	01- Intermittent inducer motor issues-Adoption Area-1/30/24	BC 2023-074	05/24/2024	1,528.73
1537 - Indiana Door & Hardware Specialties, INC	01-Entry lock to accept city core	BC 2023-076	05/24/2024	218.00
Account 53610 - Building Repairs Totals			Invoice 2 Transactions	<u>\$1,746.73</u>
Program 010000 - Main Totals			Invoice 25 Transactions	<u>\$12,538.41</u>



Board of Public Works Claim Register

Invoice Date Range 05/11/24 - 05/24/24

Program **010001 - Donations Over \$5K**

Account **52420 - Other Supplies**

8541 - Amazon.com Sales, INC (Amazon.com Services LLC)	01 - toner for intake printer	05/24/2024	117.89
6530 - Office Depot, INC	01 - Desk for Animal Control Office	05/24/2024	494.09
Account 52420 - Other Supplies Totals		Invoice 2	\$611.98
		Transactions	

Account **53130 - Medical**

6529 - BloomingPaws, LLC	01-exam with x-rays-Harper	05/24/2024	268.20
6529 - BloomingPaws, LLC	01-dental surgery-Sturgis	05/24/2024	231.90
6529 - BloomingPaws, LLC	01-spay-Moana	05/24/2024	136.40
6529 - BloomingPaws, LLC	01-HTW Treatments-Lisbeth	05/24/2024	208.68
6529 - BloomingPaws, LLC	01-neuter surgery-Curtains	05/24/2024	55.90
6529 - BloomingPaws, LLC	01-spay-Lucy	05/24/2024	115.90
6529 - BloomingPaws, LLC	01-cherry eye repair surgery-Tommy	05/24/2024	340.88
6529 - BloomingPaws, LLC	01-Heartworm Treatment-Jerica	05/24/2024	85.68
6529 - BloomingPaws, LLC	01-Heartworm Treatment-Delia	05/24/2024	90.68
3929 - IDEXX Laboratories, INC	01-Lab based blood work	05/24/2024	97.53
Account 53130 - Medical Totals		Invoice 10	\$1,631.75
		Transactions	
Program 010001 - Donations Over \$5K Totals		Invoice 12	\$2,243.73
		Transactions	
Department 01 - Animal Shelter Totals		Invoice 37	\$14,782.14
		Transactions	

Department **02 - Public Works**

Program **020000 - Main**

Account **46060 - Other Violations**

Jennifer Pawlitz	26-Customer mailed in a check for \$60, only owed \$30	05/24/2024	30.00
------------------	--	------------	-------



Board of Public Works Claim Register

Invoice Date Range 05/11/24 - 05/24/24

Account 46060 - Other Violations Totals		Invoice 1	\$30.00
		Transactions	
Account 52420 - Other Supplies			
8541 - Amazon.com Sales, INC (Amazon.com Services LLC)	02-PW Offices-mounting equip/TV's & technology equip	05/24/2024	6,099.80
Account 52420 - Other Supplies Totals		Invoice 1	\$6,099.80
		Transactions	
Account 53210 - Telephone			
1079 - AT&T	02-Radio circuits-phone charges 03/29-04/28/24	05/15/2024	180.23
Account 53210 - Telephone Totals		Invoice 1	\$180.23
		Transactions	
Account 53710 - Land Rental			
1136 - The Indiana Rail Road Company	02-Polly Grimshaw-Trail Lease w/IN Railroad-6/10/24-6/9/25	05/24/2024	1,885.73
Account 53710 - Land Rental Totals		Invoice 1	\$1,885.73
		Transactions	
Account 53990 - Other Services and Charges			
3560 - First Financial Bank / Credit Cards	28-Refund Apple WarrantvDeductible AdamWason Laptop	05/24/2024	(299.00)
Account 53990 - Other Services and Charges Totals		Invoice 1	(\$299.00)
		Transactions	
Program 020000 - Main Totals		Invoice 5	\$7,896.76
		Transactions	
Department 02 - Public Works Totals		Invoice 5	\$7,896.76
		Transactions	
Department 03 - City Clerk			
Program 030000 - Main			
Account 47060 - Refunds			
3560 - First Financial Bank / Credit Cards	03-International Inst Municiple Clerk-refund	05/24/2024	(170.00)
Account 47060 - Refunds Totals		Invoice 1	(\$170.00)
		Transactions	
Account 52420 - Other Supplies			
8541 - Amazon.com Sales, INC (Amazon.com Services LLC)	03-Logitech bluetooth keyboard clerk's office	05/24/2024	49.99
Account 52420 - Other Supplies Totals		Invoice 1	\$49.99
		Transactions	



Board of Public Works Claim Register

Invoice Date Range 05/11/24 - 05/24/24

Account 53230 - Travel

3560 - First Financial Bank / Credit Cards

03-Hyatt Regency Calgary-deposit-Deputy Clerk-IIMC Conf	05/24/2024	202.98
Account 53230 - Travel Totals	Invoice 1	<u>\$202.98</u>
Program 030000 - Main Totals	Transactions Invoice 3	<u>\$82.97</u>
Department 03 - City Clerk Totals	Transactions Invoice 3	<u>\$82.97</u>
	Transactions	

Department 04 - Economic & Sustainable Dev

Program 040000 - Main

Account 52110 - Office Supplies

8541 - Amazon.com Sales, INC (Amazon.com Services LLC)

04-Zip Ties for Artwork for Barriers for Parklettes, Stickv note	05/24/2024	29.80
Account 52110 - Office Supplies Totals	Invoice 1	<u>\$29.80</u>
	Transactions	

Account 53220 - Postage

3560 - First Financial Bank / Credit Cards

04-USPS-Postal fees-artwork for 2023 COB underground exhibition	05/24/2024	73.75
Account 53220 - Postage Totals	Invoice 1	<u>\$73.75</u>
	Transactions	

Account 53910 - Dues and Subscriptions

3560 - First Financial Bank / Credit Cards

04-MailChimp Monthly Subscription - April 2024	05/24/2024	45.00
Account 53910 - Dues and Subscriptions Totals	Invoice 1	<u>\$45.00</u>
	Transactions	

Account 53940 - Temporary Contractual Employee

203 - INDIANA UNIVERSITY

04-McKinney Climate Fellow - Fall 2024	05/24/2024	2,200.00
Account 53940 - Temporary Contractual Employee Totals	Invoice 1	<u>\$2,200.00</u>
	Transactions	

Account 53960 - Grants

4397 - A & D Cycling Enterprises, LLC (Revolution Bike)

04-E-Bike Voucher Program 05/06/24-Ferreira & Josephv	05/24/2024	1,000.00
Account 53960 - Grants Totals	Invoice 1	<u>\$1,000.00</u>
	Transactions	

Account 53970 - Mayor's Promotion of Business



Board of Public Works Claim Register

Invoice Date Range 05/11/24 - 05/24/24

8321 - Honar Ali (Huner Emin)	04-Art Studio Space Insurance Reimbursement	05/24/2024	250.00
3560 - First Financial Bank / Credit Cards	04-Square Donuts for BAC Grant Review Session-4/21/24	05/24/2024	45.71
3560 - First Financial Bank / Credit Cards	04-Square Donuts for BAC Grant Review Session-4/20/24	05/24/2024	43.12
3560 - First Financial Bank / Credit Cards	04-Upland - Lunch for Duke Artists-4/25/24	05/24/2024	64.00
4610 - Hopscotch Coffee, LLC	04: Rental Space Fee for Artist Party	05/24/2024	400.00
Account 53970 - Mayor's Promotion of Business Totals		Invoice 5	<u>\$802.83</u>
		Transactions	
Program 040000 - Main Totals		Invoice 10	<u>\$4,151.38</u>
		Transactions	
Program 04CRED - ESD CRED			
Account 53960 - Grants			
8541 - Amazon.com Sales, INC (Amazon.com Services LLC)	04-Zip Ties for Artwork for Barriers for Parklettes, Stickv note	05/24/2024	114.99
1051 - Bloomington Economic Development Corp	04-BEDC Annual Leadership Sponsorship 2024	05/24/2024	1,000.00
205 - City Of Bloomington	04-2024 Women's History Month Luncheon-3 tickets	05/24/2024	105.00
53125 - Mr. Copy, INC	04-15 Outdoor Public Art Banners	05/24/2024	2,720.00
Account 53960 - Grants Totals		Invoice 4	<u>\$3,939.99</u>
		Transactions	
Program 04CRED - ESD CRED Totals		Invoice 4	<u>\$3,939.99</u>
		Transactions	
Department 04 - Economic & Sustainable Dev Totals		Invoice 14	<u>\$8,091.37</u>
		Transactions	
Department 05 - Common Council			
Program 050000 - Main			
Account 53170 - Mgt. Fee, Consultants, and Workshops			
3560 - First Financial Bank / Credit Cards	05 - Local Progress Conference Registration - Rosenbarer	05/24/2024	300.00
Account 53170 - Mgt. Fee, Consultants, and Workshops Totals		Invoice 1	<u>\$300.00</u>
		Transactions	
Program 050000 - Main Totals		Invoice 1	<u>\$300.00</u>
		Transactions	
Department 05 - Common Council Totals		Invoice 1	<u>\$300.00</u>
		Transactions	



Board of Public Works Claim Register

Invoice Date Range 05/11/24 - 05/24/24

Department **06 - Controller's Office**

Program **060000 - Main**

Account **53730 - Machinery and Equipment Rental**

371 - Pitney Bowes, INC

06-analytics, basic cost acct for mail machine-1/26-4/25/24	05/24/2024	285.12
Account 53730 - Machinery and Equipment Rental Totals	Invoice 1	<u>\$285.12</u>
	Transactions	

Account **53990 - Other Services and Charges**

5648 - Reedy Financial Group, PC

06-Annexation Consulting/printing etc-billing through 4/30/2024	05/24/2024	17,160.38
Account 53990 - Other Services and Charges Totals	Invoice 1	<u>\$17,160.38</u>
	Transactions	
Program 060000 - Main Totals	Invoice 2	<u>\$17,445.50</u>
	Transactions	
Department 06 - Controller's Office Totals	Invoice 2	<u>\$17,445.50</u>
	Transactions	

Department **07 - Engineering**

Program **070000 - Main**

Account **52110 - Office Supplies**

8541 - Amazon.com Sales, INC (Amazon.com Services LLC)

07-07-Logitech wireless trackball mouse K Baugh	05/24/2024	39.99
Account 52110 - Office Supplies Totals	Invoice 1	<u>\$39.99</u>
	Transactions	

Account **53160 - Instruction**

3560 - First Financial Bank / Credit Cards

07-ITE-Webinar-Turn Conflicts w/Vulnerable Road User (N Konner)	05/24/2024	20.00
Account 53160 - Instruction Totals	Invoice 1	<u>\$20.00</u>
	Transactions	

Account **53910 - Dues and Subscriptions**

3560 - First Financial Bank / Credit Cards

07-doxpop Subscription Public Records Access 04/13/24-5/12/24	05/24/2024	21.75
Account 53910 - Dues and Subscriptions Totals	Invoice 1	<u>\$21.75</u>
	Transactions	

Account **54310 - Improvements Other Than Building**

5818 - Service Solutions of Bloomington (Taycon)

07-Liberty Drive Sidewalk (CN) 02/12-04/18/24-Lump sum	BC 2023-100 05/24/2024	40,651.73
--	------------------------	-----------



Board of Public Works Claim Register

Invoice Date Range 05/11/24 - 05/24/24

Account 54310 - Improvements Other Than Building Totals		Invoice 1	\$40,651.73
		Transactions	
Program 070000 - Main Totals		Invoice 4	\$40,733.47
		Transactions	
Department 07 - Engineering Totals		Invoice 4	\$40,733.47
		Transactions	
Department 09 - CFRD			
Program 090000 - Main			
Account 52110 - Office Supplies			
6530 - Office Depot, INC	09- White Cardstock, 5 Moving Boxes	05/24/2024	57.04
6530 - Office Depot, INC	09-Office Supplies-Tissues	05/24/2024	54.44
	Account 52110 - Office Supplies Totals	Invoice 2	\$111.48
		Transactions	
Account 52420 - Other Supplies			
8541 - Amazon.com Sales, INC (Amazon.com Services LLC)	09-Events-Cups for Hot and Cold Drinks-50 pack and 600 pack	05/24/2024	52.24
651 - Engraving & Stamp Center, INC	09-Human Rights Award Plaques-2 Engraved Glass Awards	05/24/2024	175.70
55092 - WonderLab Museum of Science, Health & Technology	09-93 Wonderpasses-Human Rights Art & Essay Contest Prizes	05/24/2024	744.00
	Account 52420 - Other Supplies Totals	Invoice 3	\$971.94
		Transactions	
Account 53910 - Dues and Subscriptions			
3560 - First Financial Bank / Credit Cards	09-Constant Contact Monthly-Newsletter Service-April 2024	05/24/2024	145.00
3560 - First Financial Bank / Credit Cards	09-Animoto Annual Subscription-Video & Slideshow Edit Platform	05/24/2024	264.00
3560 - First Financial Bank / Credit Cards	09-Zoom One Pro License-cfrdadadmin account-4/1/24-3/31/25	05/24/2024	149.90
	Account 53910 - Dues and Subscriptions Totals	Invoice 3	\$558.90
		Transactions	
Account 53940 - Temporary Contractual Employee			
203 - INDIANA UNIVERSITY	09-Indiana Leadership Program-Internship Fee for Lauren Murrav	05/24/2024	750.00
	Account 53940 - Temporary Contractual Employee Totals	Invoice 1	\$750.00
		Transactions	
	Program 090000 - Main Totals	Invoice 9	\$2,392.32
		Transactions	



Board of Public Works Claim Register

Invoice Date Range 05/11/24 - 05/24/24

Department 09 - CFRD Totals		Invoice 9	<u>\$2,392.32</u>
Department 10 - Legal		Transactions	
Program 100000 - Main			
Account 53160 - Instruction			
259 - Indiana Association Of Cities & Towns (AIM)	10-Seminar Fees - 7 attorneys MR, LA, CW, HLL, AB, AP. EK	05/24/2024	2,560.00
Account 53160 - Instruction Totals		Invoice 1	<u>\$2,560.00</u>
Account 53910 - Dues and Subscriptions		Transactions	
7712 - Indiana Municipal Lawyers Assoc., INC (IMLA)	10- Membership Dues - Kassamanian and Holmes	05/24/2024	170.00
Account 53910 - Dues and Subscriptions Totals		Invoice 1	<u>\$170.00</u>
Account 53990 - Other Services and Charges		Transactions	
7855 - Veritext LLC	10-Transcription Fees - Police Pension Board 7154006	05/24/2024	571.70
Account 53990 - Other Services and Charges Totals		Invoice 1	<u>\$571.70</u>
Program 100000 - Main Totals		Transactions	
Department 10 - Legal Totals		Invoice 3	<u>\$3,301.70</u>
		Transactions	
Department 11 - Mayor's Office		Invoice 3	<u>\$3,301.70</u>
Program 110000 - Main		Transactions	
Account 43380 - Other Services			
9283 - Scott Kellogg	11-music (Splattertones) for reception-State of the City	05/24/2024	500.00
Account 43380 - Other Services Totals		Invoice 1	<u>\$500.00</u>
Account 47080 - Other Reimbursements		Transactions	
8363 - Rose Smith	11 - food for Town and Gown-5/2/24	05/24/2024	38.67
8363 - Rose Smith	11 - food for Town and Gown-Sams Club-5/2/24	05/24/2024	32.61
Account 47080 - Other Reimbursements Totals		Invoice 2	<u>\$71.28</u>
		Transactions	



Board of Public Works Claim Register

Invoice Date Range 05/11/24 - 05/24/24

Account 52110 - Office Supplies

651 - Engraving & Stamp Center, INC	11 - stamp for police & fire swearing in documents	05/24/2024	90.35
	Account 52110 - Office Supplies Totals	Invoice 1	\$90.35
		Transactions	

Account 53160 - Instruction

9158 - Krista Padgett	11-prof coaching/consult for Mayor & staff April 2024-final nav	05/24/2024	600.00
	Account 53160 - Instruction Totals	Invoice 1	\$600.00
		Transactions	

Account 53170 - Mgt. Fee, Consultants, and Workshops

9138 - Jeffery R Harris	11-communications services 04/01/24-04/30/24	05/24/2024	3,900.00
9138 - Jeffery R Harris	11-communications services 01/29/24-02/29/24	05/24/2024	4,150.00
259 - Indiana Association Of Cities & Towns (AIM)	11 - Mayor's Institute conference fee	05/24/2024	219.00
	Account 53170 - Mgt. Fee, Consultants, and Workshops Totals	Invoice 3	\$8,269.00
		Transactions	

Account 53910 - Dues and Subscriptions

5954 - The Greater Bloomington Chamber Of Commerce, INC	11 - Membership dues for 2024	05/24/2024	1,240.00
	Account 53910 - Dues and Subscriptions Totals	Invoice 1	\$1,240.00
		Transactions	

Account 53990 - Other Services and Charges

7703 - Smokin' Jacks Rib Shack, LLC (Blooming Boards)	11-State of City Address 2024 reception-4/9/24	05/24/2024	1,539.90
	Account 53990 - Other Services and Charges Totals	Invoice 1	\$1,539.90
		Transactions	
	Program 110000 - Main Totals	Invoice 10	\$12,310.53
		Transactions	
	Department 11 - Mayor's Office Totals	Invoice 10	\$12,310.53
		Transactions	

Department 12 - Human Resources

Program 120000 - Main

Account 53170 - Mgt. Fee, Consultants, and Workshops

732 - Barbara E McKinney	12-consulting - Review of draft telecommuting policy	05/24/2024	125.00
--------------------------	--	------------	--------



Board of Public Works Claim Register

Invoice Date Range 05/11/24 - 05/24/24

Account 53170 - Mgt. Fee, Consultants, and Workshops Totals		Invoice 1	\$125.00
		Transactions	
Account 53990 - Other Services and Charges			
8882 - Employers Choice Online INC	12-Background checks - 13-4/30/24	05/24/2024	469.27
8609 - LoCascio Hadden & Dennis, LLC (LHD Benefit Advisor)	12-Near-Site Employer Clinic Support May 2024	05/24/2024	2,600.00
Account 53990 - Other Services and Charges Totals		Invoice 2	\$3,069.27
		Transactions	
Program 120000 - Main Totals		Invoice 3	\$3,194.27
		Transactions	
Department 12 - Human Resources Totals		Invoice 3	\$3,194.27
		Transactions	
Department 13 - Planning			
Program 130000 - Main			
Account 52110 - Office Supplies			
8541 - Amazon.com Sales, INC (Amazon.com Services LLC)	13- Super Glue	05/24/2024	11.93
5099 - Office Three Sixty, INC	13- Printable Post Cards	05/24/2024	29.38
Account 52110 - Office Supplies Totals		Invoice 2	\$41.31
		Transactions	
Account 53160 - Instruction			
8704 - Diversified Communications (Admin. Profess. Conf.)	13-Registration-Admin Professionals Conf-Hirtzel-CO-Oct 2024	05/24/2024	1,750.00
3560 - First Financial Bank / Credit Cards	13-APA Webinar for David Hittle	05/24/2024	20.00
Account 53160 - Instruction Totals		Invoice 2	\$1,770.00
		Transactions	
Account 53230 - Travel			
8807 - Jennifer Burrell	13-reimb per diem/Uber/mileage-APA Conf-MN-4/12-4/16/24	05/24/2024	437.73
3560 - First Financial Bank / Credit Cards	13-hotel-4/12-4/16-Burrell-2024 Nat'l Planning Conf-MN-balance	05/24/2024	82.92
Account 53230 - Travel Totals		Invoice 2	\$520.65
		Transactions	
Account 53990 - Other Services and Charges			
5247 - Robert Hudson (Graphic Visions)	13- 75 Zoning Request Pending Yard Signs	05/24/2024	1,012.50



Board of Public Works Claim Register

Invoice Date Range 05/11/24 - 05/24/24

Department **16 - Sanitation**
 Program **160000 - Main**
 Account **53990 - Other Services and Charges**
 7146 - Routeware, INC

Account **53990 - Other Services and Charges** Totals
 Program **130000 - Main** Totals
 Department **13 - Planning** Totals

Invoice 1	\$1,012.50
Transactions	
Invoice 7	\$3,344.46
Transactions	
Invoice 7	\$3,344.46
Transactions	

16-Travel expenses for technician - January 2024

Account **53990 - Other Services and Charges** Totals
 Program **160000 - Main** Totals
 Department **16 - Sanitation** Totals

05/24/2024	2,916.75
Invoice 1	\$2,916.75
Transactions	
Invoice 1	\$2,916.75
Transactions	
Invoice 1	\$2,916.75
Transactions	

Department **19 - Facilities Maintenance**
 Program **190000 - Main**

Account **52310 - Building Materials and Supplies**

8541 - Amazon.com Sales, INC (Amazon.com Services LLC) 19 - fan blower and replacement keys
 409 - Black Lumber Co. INC 19- Makita 1/2 Drill for Facilities (City Hall)
 138 - Gooldy & Sons, INC 19 - City Hall faucet fixture stock-includes \$170.00 credit
 293 - J&S Locksmith Shop, INC 19 - Key made-includes code lookup
 8658 - Kleindorfer's Hardware LLC 19-paint, sprayer, dandelion tool, spray bottles, aardenina tool
 8658 - Kleindorfer's Hardware LLC 19- pik stiks, kitchen sink, teks, rubbing alcohol, pipe cleaner
 8658 - Kleindorfer's Hardware LLC 19 - steel wool, old english, swiffer & pads, screws, light bulb
 8658 - Kleindorfer's Hardware LLC 19- (14) no trespassing signs for 714 Rogers (RDC)

05/24/2024	21.81
05/24/2024	69.97
05/24/2024	25.00
05/24/2024	26.35
05/24/2024	128.76
05/24/2024	207.64
05/24/2024	60.94
05/24/2024	12.46

Account **52310 - Building Materials and Supplies** Totals

Invoice 8	\$552.93
Transactions	

Account **52430 - Uniforms and Tools**



Board of Public Works Claim Register

Invoice Date Range 05/11/24 - 05/24/24

8541 - Amazon.com Sales, INC (Amazon.com Services LLC)	19 - replacement parts for staple gun-spring, gasket, head valve	05/24/2024	24.74
8541 - Amazon.com Sales, INC (Amazon.com Services LLC)	19 - credit for return of tool batteries-Inv #1WMV-CVVM-4DGC	05/24/2024	(103.68)
19171 - Vestis Group, INC	19- Uniform pants-R. Flake-4/25/24	05/24/2024	14.20
19171 - Vestis Group, INC	19- Uniform pants-R. Flake-5/2/24	05/24/2024	14.20
798 - Winters Associates Promotional Products, INC	19 - Brighten B-Town safety vests (25)	05/24/2024	658.45

Account **52430 - Uniforms and Tools** Totals Invoice 5 Transactions \$607.91

Account **53530 - Water and Sewer**

208 - City Of Bloomington Utilities	19-City Hall-water/sewer bill - April 2024	05/15/2024	1,205.49
208 - City Of Bloomington Utilities	19-Temp Mtr-Graffiti Team-water/sewer bill-April 2024	05/15/2024	16.16

Account **53530 - Water and Sewer** Totals Invoice 2 Transactions \$1,221.65

Account **53610 - Building Repairs**

5012 - Allegion Access Technologies, LLC	19 - City Hall main door repair-service call-4/24/24	05/24/2024	392.00
651 - Engraving & Stamp Center, INC	19 - City Hall ADA and braille signage	05/24/2024	388.08
651 - Engraving & Stamp Center, INC	19 - City Hall agenda holders (5)	05/24/2024	247.25
651 - Engraving & Stamp Center, INC	19 - City Hall nameplates (4)	05/24/2024	64.32
321 - Harrell Fish, INC (HFI)	19 - SA City Hall quarterly planned maintenance -May 2024 BC 2023-074	05/24/2024	2,088.00
321 - Harrell Fish, INC (HFI)	19 - SA repair air conditioning-lobby of OOTM--4/18/24 BC 2023-074	05/24/2024	1,247.00
1537 - Indiana Door & Hardware Specialties, INC	19 - SA door repair for ITS-Sargent mortise lock chassis BC 2023-076	05/24/2024	594.00
7402 - Nature's Way, INC	19- Monthly Plant Maintenance @ City Hall-5/1/24 BC 2023-102	05/24/2024	371.10

Account **53610 - Building Repairs** Totals Invoice 8 Transactions \$5,391.75

Program **190000 - Main** Totals Invoice 23 \$7,774.24

Department **19 - Facilities Maintenance** Totals Invoice 23 Transactions \$7,774.24

Department **28 - ITS**



Board of Public Works Claim Register

Invoice Date Range 05/11/24 - 05/24/24

Program **280000 - Main**

Account **52420 - Other Supplies**

8541 - Amazon.com Sales, INC (Amazon.com Services LLC)	28-GIS Office Light Bulbs	05/24/2024	16.49
	Account 52420 - Other Supplies Totals	Invoice 1	\$16.49
		Transactions	

Account **53230 - Travel**

3560 - First Financial Bank / Credit Cards	28-Lodging for IGIC Conf. Blue Chip Hotel-C. Moore-5/15-5/17/24	05/24/2024	221.98
3560 - First Financial Bank / Credit Cards	28-R Dietz Flight for Smart City Conf-North Carolina	05/24/2024	649.20
	Account 53230 - Travel Totals	Invoice 2	\$871.18
		Transactions	

Account **53640 - Hardware and Software Maintenance**

3560 - First Financial Bank / Credit Cards	28-Royal Apps - Software for Hardware Management	05/24/2024	50.00
3989 - Ricoh USA, INC	28-City Civil Printer/Copier Maintenance 03/17-04/16/24	05/24/2024	2,030.09
3989 - Ricoh USA, INC	28-City Civil Printer/Copier Maintenance 03/17-04/16/24	05/24/2024	324.06
3989 - Ricoh USA, INC	28-City Civil Printer/Copier Maintenance 04/01-04/30/24	05/24/2024	39.79
3989 - Ricoh USA, INC	28-4th St Garage-Copier/Printer Maint- 04/01-04/30/24	05/24/2024	250.75
	Account 53640 - Hardware and Software Maintenance Totals	Invoice 5	\$2,694.69
		Transactions	

Account **53910 - Dues and Subscriptions**

3560 - First Financial Bank / Credit Cards	28-Airtable - Subscription -4/23/24	05/24/2024	201.28
3560 - First Financial Bank / Credit Cards	28-Zoom Timer Subscription 04/04/24	05/24/2024	89.95
3560 - First Financial Bank / Credit Cards	28-Google - April 2024 Cloud Services	05/24/2024	200.00
3560 - First Financial Bank / Credit Cards	28-Google - Domain Renewal bloomington.dev/bton.in	05/24/2024	24.00
3560 - First Financial Bank / Credit Cards	28-Google Domain Renewal btowncops.org-4/8/24	05/24/2024	12.00
3560 - First Financial Bank / Credit Cards	28-Google March 2024 Cloud Services	05/24/2024	85.18
3560 - First Financial Bank / Credit Cards	28- PartedMagic hard disc management - Subscription 2024 O2	05/24/2024	13.00



Board of Public Works Claim Register

Invoice Date Range 05/11/24 - 05/24/24

3560 - First Financial Bank / Credit Cards	28-Submittable - Application Sub Software 04/27/24-05/27/24	05/24/2024	119.00
3560 - First Financial Bank / Credit Cards	28-Zoom - Subscriptions & Storage Fees 04/20/24-05/19/24	05/24/2024	430.00
8441 - Promevo Holdings, INC (Promevo, LLC)	28-Google Enterprise & gPanel Renewal 0& Archive April 2024	05/24/2024	155.12
8441 - Promevo Holdings, INC (Promevo, LLC)	28 - Google Voice Monthly Subscription April 2024	05/24/2024	48.33
2998 - Seiler Instrument & Mfg Co, INC	28-GIS Field Data Collection Kits 12 Month expiry	05/24/2024	1,365.00
	Account 53910 - Dues and Subscriptions Totals	Invoice 12	<u>\$2,742.86</u>
		Transactions	
	Program 280000 - Main Totals	Invoice 20	<u>\$6,325.22</u>
		Transactions	
	Department 28 - ITS Totals	Invoice 20	<u>\$6,325.22</u>
		Transactions	
	Fund 101 - General Fund (S0101) Totals	Invoice 142	<u>\$130,891.70</u>
		Transactions	
Fund 103 - Restricted Donations(ord 05-17)			
Department 06 - Controller's Office			
Program 400101 - Animal Medical Services			
Account 53130 - Medical			
6529 - BloomingPaws, LLC	01-exam with x-rays-Barry B Benson	05/24/2024	100.00
3929 - IDEXX Laboratories, INC	01-Lab based blood work	05/24/2024	265.88
175 - Monroe County Humane Association, INC	01-Diagnostics, Vet Exams, X-rays	05/24/2024	239.45
	Account 53130 - Medical Totals	Invoice 3	<u>\$605.33</u>
		Transactions	
	Program 400101 - Animal Medical Services Totals	Invoice 3	<u>\$605.33</u>
		Transactions	
Program 400102 - Animal Supplies			
Account 52210 - Institutional Supplies			
8541 - Amazon.com Sales, INC (Amazon.com Services LLC)	01-3 air horns	05/24/2024	44.97
4633 - Midwest Veterinary Supply, INC	01 - Heartworm medication-Diroban	05/24/2024	1,100.75
	Account 52210 - Institutional Supplies Totals	Invoice 2	<u>\$1,145.72</u>
		Transactions	



Board of Public Works Claim Register

Invoice Date Range 05/11/24 - 05/24/24

Account 52310 - Building Materials and Supplies

4394 - Richardson Enterprises of Blgtn,LLC (FastSigns)

01 - Shelter Signs 05/24/2024 696.78

Account 52310 - Building Materials and Supplies Totals	Invoice 1	\$696.78
Program 400102 - Animal Supplies Totals	Transactions Invoice 3	\$1,842.50
Department 06 - Controller's Office Totals	Transactions Invoice 6	\$2,447.83
Fund 103 - Restricted Donations(ord 05-17) Totals	Transactions Invoice 6	\$2,447.83
	Transactions	

Fund 153 - LIT – Economic Development

Department **04 - Economic & Sustainable Dev**

Program **040000 - Main**

Account **53960 - Grants**

8737 - ADS Consulting INC (Stone Municipal Group)

04-Enterprise Zone Invest Deduction (EZID) Cons 05/24/2024 2,655.00

1051 - Bloomington Economic Development Corp

Work-April 2024
04-BEDC Annual Leadership Sponsorship 2024 05/24/2024 1,500.00

585 - Bloomington Public Transportation Corporation

04-BT Interlocal Cooperative Agreement 2024 05/24/2024 3,806,100.00

8448 - TEN31 Marketing LLC

04-Marketing Services for Go Bloomington April 2024 05/24/2024 9,145.00

8550 - Veregy IN, LLC

04-Solar Array Repairs at Dillman System B 05/24/2024 5,897.97

Account 53960 - Grants Totals	Invoice 5	\$3,825,297.97
Program 040000 - Main Totals	Transactions Invoice 5	\$3,825,297.97
Department 04 - Economic & Sustainable Dev Totals	Transactions Invoice 5	\$3,825,297.97
	Transactions	

Department **12 - Human Resources**

Program **120000 - Main**

Account **53990 - Other Services and Charges**

8834 - Seth D Staggs

12-Education Reimbursement - December 2023 05/24/2024 1,150.00

Account 53990 - Other Services and Charges Totals	Invoice 1	\$1,150.00
	Transactions	



Board of Public Works Claim Register

Invoice Date Range 05/11/24 - 05/24/24

		Program 120000 - Main Totals	Invoice 1	\$1,150.00
			Transactions	
		Department 12 - Human Resources Totals	Invoice 1	\$1,150.00
			Transactions	
Department 19 - Facilities Maintenance				
Program 190000 - Main				
Account 53610 - Building Repairs				
6688 - SSW Enterprises, LLC (Office Pride)	19- April 2024 Cleaning Services for Animal Care & Control		05/24/2024	1,454.05
6688 - SSW Enterprises, LLC (Office Pride)	19- April 2024 Cleaning Services for City Hall		05/24/2024	14,308.80
6688 - SSW Enterprises, LLC (Office Pride)	19- April 2024 Cleaning Services for Sanitation		05/24/2024	889.92
6688 - SSW Enterprises, LLC (Office Pride)	19- April 2024 Cleaning Services for Street/Traffic		05/24/2024	1,745.92
		Account 53610 - Building Repairs Totals	Invoice 4	\$18,398.69
			Transactions	
		Program 190000 - Main Totals	Invoice 4	\$18,398.69
			Transactions	
		Department 19 - Facilities Maintenance Totals	Invoice 4	\$18,398.69
			Transactions	
		Fund 153 - LIT – Economic Development Totals	Invoice 10	\$3,844,846.66
			Transactions	
Fund 160 - IFA CoronaVirus Relief Fnd21.019				
Department 06 - Controller's Office				
Program G20018 - IFA Corona Virus Relief Fund				
Account 53990 - Other Services and Charges				
250 - Crowe LLP	12 - Classification and Compensation Study 2023 - Jan-March 2024		05/24/2024	11,063.69
		Account 53990 - Other Services and Charges Totals	Invoice 1	\$11,063.69
			Transactions	
		Program G20018 - IFA Corona Virus Relief Fund Totals	Invoice 1	\$11,063.69
			Transactions	
		Department 06 - Controller's Office Totals	Invoice 1	\$11,063.69
			Transactions	
		Fund 160 - IFA CoronaVirus Relief Fnd21.019 Totals	Invoice 1	\$11,063.69
			Transactions	
Fund 176 - ARPA Local Fiscal Recvry (S9512)				



Board of Public Works Claim Register

Invoice Date Range 05/11/24 - 05/24/24

Department **07 - Engineering**

Program **G21005 - ARPA COVID Local Fiscal Recovery**

Account **54310 - Improvements Other Than Building**

5149 - E&B Paving, INC

07-Morningside DR Greenway (CN) 02/12-05/01/24- App 1	BC 2023-106	05/24/2024	286,146.55
Account 54310 - Improvements Other Than Building Totals		Invoice 1	<u>\$286,146.55</u>
		Transactions	
Program G21005 - ARPA COVID Local Fiscal Recovery Totals		Invoice 1	<u>\$286,146.55</u>
		Transactions	
Department 07 - Engineering Totals		Invoice 1	<u>\$286,146.55</u>
		Transactions	
Fund 176 - ARPA Local Fiscal Recvry (\$9512) Totals		Invoice 1	<u>\$286,146.55</u>
		Transactions	

Fund **249 - Grants Non Approp**

Department **04 - Economic & Sustainable Dev**

Program **G24006 - 2024 Economic Devel Adj Assist**

Account **53960 - Grants**

3885 - Building Associates, INC

04-Trades District Tech Center-App 5 (Inv #14911) 05/24/2024 414,392.78

3885 - Building Associates, INC

04-Trades District Tech Center-App 6 (Inv #14922) 05/24/2024 285,520.60

	Account 53960 - Grants Totals	Invoice 2	<u>\$699,913.38</u>
		Transactions	
Program G24006 - 2024 Economic Devel Adj Assist Totals		Invoice 2	<u>\$699,913.38</u>
		Transactions	
Department 04 - Economic & Sustainable Dev Totals		Invoice 2	<u>\$699,913.38</u>
		Transactions	
Fund 249 - Grants Non Approp Totals		Invoice 2	<u>\$699,913.38</u>
		Transactions	

Fund **312 - Community Services**

Department **09 - CFRD**

Program **090002 - Com Serv - MLK Comm**

Account **52420 - Other Supplies**

8002 - Safeguard Business Systems, INC

09-MLK 2024 Program-500 ct-Adjusted Price Due to Error 05/24/2024 209.73



Board of Public Works Claim Register

Invoice Date Range 05/11/24 - 05/24/24

Account 52420 - Other Supplies Totals		Invoice 1	\$209.73
Account 53310 - Printing		Transactions	
8002 - Safeguard Business Systems, INC	09-MLK 2024 Program-500 ct-Adjusted Price Due to Error	05/24/2024	.00
Account 53310 - Printing Totals		Invoice 1	\$0.00
Program 090002 - Com Serv - MLK Comm Totals		Transactions	
		Invoice 2	\$209.73
Program 090016 - Com Serv - Safe & Civil		Transactions	
Account 53990 - Other Services and Charges			
3560 - First Financial Bank / Credit Cards	09-Safe and Civil City Jotform-4/23-5/23/24-Acct 1-moss	05/24/2024	19.00
Account 53990 - Other Services and Charges Totals		Invoice 1	\$19.00
Program 090016 - Com Serv - Safe & Civil Totals		Transactions	
		Invoice 1	\$19.00
Program 090018 - CBVN		Transactions	
Account 52420 - Other Supplies			
11693 - The Award Center, INC	09-Be More Awards 2024-Set-up and Creation of 8 Enraved Awards	05/24/2024	512.00
Account 52420 - Other Supplies Totals		Invoice 1	\$512.00
Account 53990 - Other Services and Charges		Transactions	
1138 - BCT Management, INC	09-Be More Awards-Tech Labor, Equipment, Parking, Marketing-4/25	05/24/2024	550.00
Account 53990 - Other Services and Charges Totals		Invoice 1	\$550.00
Program 090018 - CBVN Totals		Transactions	
		Invoice 2	\$1,062.00
Department 09 - CFRD Totals		Transactions	
Fund 312 - Community Services Totals		Invoice 5	\$1,290.73
		Transactions	
		Invoice 5	\$1,290.73
		Transactions	
Fund 401 - Non-Reverting Telecom (S1146)			
Department 25 - Telecommunications			
Program 254000 - Infrastructure			



Board of Public Works Claim Register

Invoice Date Range 05/11/24 - 05/24/24

Account **53640 - Hardware and Software Maintenance**

13482 - Northern Lights Locating & Inspection, INC	28-BDU Line Locates & Emerg Call Fees April 2024	05/24/2024	2,500.00
Account 53640 - Hardware and Software Maintenance Totals		Invoice 1	<u>\$2,500.00</u>
Program 254000 - Infrastructure Totals		Transactions Invoice 1	<u>\$2,500.00</u>
		Transactions	

Program **256000 - Services**

Account **53150 - Communications Contract**

4170 - Comcast Cable Communications, INC	28-3940 N Kinser Pike-business serv./equip chgs-05/21-06/20/24	05/15/2024	169.86
Account 53150 - Communications Contract Totals		Invoice 1	<u>\$169.86</u>
		Transactions	

Account **54450 - Equipment**

8541 - Amazon.com Sales, INC (Amazon.com Services LLC)	28-CapR Public Works Fleet Power Cable	05/24/2024	19.98
8541 - Amazon.com Sales, INC (Amazon.com Services LLC)	28-CapR HR Lauren Anderson MAC Hard Drive	05/24/2024	94.99
8541 - Amazon.com Sales, INC (Amazon.com Services LLC)	28-CapR iPad pencil & case for Mayor	05/24/2024	262.98
8541 - Amazon.com Sales, INC (Amazon.com Services LLC)	28-CapR iPad case for Enterprise App Testing	05/24/2024	60.72
6222 - Apple, INC	28-CAPR for Enterprise Testing Apps iPad	05/24/2024	488.00
Account 54450 - Equipment Totals		Invoice 5	<u>\$926.67</u>
Program 256000 - Services Totals		Transactions Invoice 6	<u>\$1,096.53</u>
Department 25 - Telecommunications Totals		Transactions Invoice 7	<u>\$3,596.53</u>
Fund 401 - Non-Reverting Telecom (S1146) Totals		Transactions Invoice 7	<u>\$3,596.53</u>
		Transactions	

Fund **451 - Motor Vehicle Highway(S0708)**

Department **20 - Street**

Program **200000 - Main**

Account **52210 - Institutional Supplies**

313 - Fastenal Company	20-Safety Supplies for Crews-gloves, earplugs, towels	05/24/2024	175.30
------------------------	---	------------	--------



Board of Public Works Claim Register

Invoice Date Range 05/11/24 - 05/24/24

Account 52210 - Institutional Supplies Totals		Invoice 1	\$175.30
		Transactions	
Account 52310 - Building Materials and Supplies			
395 - Kirby Risk Corp	20-fan motor for bathroom repair	05/24/2024	242.56
395 - Kirby Risk Corp	20-Sup for repairs bathroom(1/2 KO snap, 1 KO snap & fan motor	05/24/2024	1.43
Account 52310 - Building Materials and Supplies Totals		Invoice 2	\$243.99
		Transactions	
Account 52340 - Other Repairs and Maintenance			
4519 - Osburn Associates, INC	20-Sign brackets (20) & R1-6 Pedestrian Signs	05/24/2024	250.00
Account 52340 - Other Repairs and Maintenance Totals		Invoice 1	\$250.00
		Transactions	
Account 52420 - Other Supplies			
8541 - Amazon.com Sales, INC (Amazon.com Services LLC)	20-Chainsaw Scabbard for Bucket Truck	05/24/2024	244.55
409 - Black Lumber Co. INC	20-(2) 1x6-10 Pine Pro for sidewalk crew	05/24/2024	13.58
409 - Black Lumber Co. INC	20-Pistol Nozzle for Street Sweepers	05/24/2024	17.98
409 - Black Lumber Co. INC	20-Mailbox mounting board and black steel mailbox for millina cr	05/24/2024	44.98
409 - Black Lumber Co. INC	20-Mailbox repair for 9292 Plymouth Ct.-post,mounting board. #'s	05/24/2024	63.54
409 - Black Lumber Co. INC	20-Hardware for mowing crews	05/24/2024	13.81
409 - Black Lumber Co. INC	20-Hardware for mowing crews	05/24/2024	1.85
409 - Black Lumber Co. INC	20-Degreaser to clean 415, tack wagon #452	05/24/2024	109.96
313 - Fastenal Company	20-4pc 20V Drill Combo Kit for Street Cut Crew	05/24/2024	781.22
3560 - First Financial Bank / Credit Cards	20-Sams Club-Food supplies for Eclipse work crews-4/4/24	05/24/2024	226.03
177 - Indiana Oxygen Company, INC	20-Propane for crews 04/15/24	05/24/2024	94.26
8658 - Kleindorfer's Hardware LLC	20-10 Gal water, (4) tarp straps	05/24/2024	102.95
8658 - Kleindorfer's Hardware LLC	20-(3) Rags n box for paving crews	05/24/2024	47.97
8658 - Kleindorfer's Hardware LLC	20-Ratchet straps for mowing crews	05/24/2024	24.99



Board of Public Works Claim Register

Invoice Date Range 05/11/24 - 05/24/24

6262 - Koenig Equipment, INC	20-Chainsaws for VanDeventer & Carroll	05/24/2024	749.30
	Account 52420 - Other Supplies Totals	Invoice 15 Transactions	<u>\$2,536.97</u>
Account 53150 - Communications Contract			
5465 - Emergency Radio Service LLC (ERS-OCI Wireless)	20-Two-way radio services for crews 05/01/24	05/24/2024	2,321.25
	Account 53150 - Communications Contract Totals	Invoice 1 Transactions	<u>\$2,321.25</u>
Account 53230 - Travel			
6991 - Tony Carroll	20-per diem-APWA Conf-Kansas City-4/27-4/30/24	05/24/2024	181.00
3560 - First Financial Bank / Credit Cards	20-Fuel-APWA Conf -Kansas City, MO-4/27-4/30- (Carroll & Morris)	05/24/2024	130.66
6123 - Jeffery W Morris	20-per diem-APWA Conf-Kansas City-4/27-4/30/24	05/24/2024	181.00
	Account 53230 - Travel Totals	Invoice 3 Transactions	<u>\$492.66</u>
Account 53250 - Pagers			
332 - Indiana Paging Network, INC	20-Pagers for Snow Control Crews June 2024	05/24/2024	158.95
	Account 53250 - Pagers Totals	Invoice 1 Transactions	<u>\$158.95</u>
Account 53530 - Water and Sewer			
208 - City Of Bloomington Utilities	20-Street Dept-fire hydrant-water/sewer bill-April 2024	05/15/2024	47.22
208 - City Of Bloomington Utilities	20-Street Dept-water/sewer bill-April 2024	05/15/2024	301.64
	Account 53530 - Water and Sewer Totals	Invoice 2 Transactions	<u>\$348.86</u>
Account 53730 - Machinery and Equipment Rental			
351 - Young Trucking, INC	20-Truck & Trailer Rental-moving sweeping equipment- 4/10/24	05/24/2024	525.00
	Account 53730 - Machinery and Equipment Rental Totals	Invoice 1 Transactions	<u>\$525.00</u>
Account 53920 - Laundry and Other Sanitation Services			
19171 - Vestis Group, INC	20-uniform rental (minus payroll ded)-5/1/24	05/24/2024	9.01
19171 - Vestis Group, INC	20-mat/towel service-5/1/24	05/24/2024	42.58



Board of Public Works Claim Register

Invoice Date Range 05/11/24 - 05/24/24

19171 - Vestis Group, INC	20-uniform rental (minus payroll ded)-5/8/24	05/24/2024	9.01
19171 - Vestis Group, INC	20-mat/towel service-5/8/24	05/24/2024	42.58
Account 53920 - Laundry and Other Sanitation Services Totals		Invoice 4	<u>\$103.18</u>
		Transactions	
Account 53990 - Other Services and Charges			
1481 - Ivy Tech Community College of Indiana	20-Training for CDL Lic (Robinson, Meadows, Bailey, Richev)	05/24/2024	17,440.00
8189 - Paragon Asset Recovery Services, LLC (Sedgwick)	20-Insurance Claim-Auto Property Damage (Badger)-4A2402N0OZL	05/24/2024	300.00
8189 - Paragon Asset Recovery Services, LLC (Sedgwick)	20-Insurance Claim-Moore(4A2402T54CG)&Badger-4A2402N0OZL(1)	05/24/2024	9,700.00
19444 - Jeffery D Todd (Todd Septic Tank Service)	20-Pump Salt Water Collection Tanks 04/18/24	05/24/2024	225.00
Account 53990 - Other Services and Charges Totals		Invoice 4	<u>\$27,665.00</u>
		Transactions	
Program 200000 - Main Totals		Invoice 35	<u>\$34,821.16</u>
		Transactions	
Department 20 - Street Totals		Invoice 35	<u>\$34,821.16</u>
		Transactions	
Fund 451 - Motor Vehicle Highway(S0708) Totals		Invoice 35	<u>\$34,821.16</u>
		Transactions	
Fund 452 - Parking Facilities(S9502)			
Department 26 - Parking			
Program 260000 - Main			
Account 52210 - Institutional Supplies			
3560 - First Financial Bank / Credit Cards	26-Sams Club-food for employees working 2024 eclipse-4/3/24	05/24/2024	48.93
3560 - First Financial Bank / Credit Cards	26-Sams Club-ice for the solar eclipse employee lunch-4/3/24	05/24/2024	11.52
5099 - Office Three Sixty, INC	26-disinfectant, window cleaner, odo ban, liquid absorbant	05/24/2024	312.98
Account 52210 - Institutional Supplies Totals		Invoice 3	<u>\$373.43</u>
		Transactions	
Account 52310 - Building Materials and Supplies			
8658 - Kleindorfer's Hardware LLC	26-Gas & Deiesel can, chain & (6) pad lock for power washer	05/24/2024	114.82
8658 - Kleindorfer's Hardware LLC	26-Paint supplies for walls at 3th Street Office	05/24/2024	56.22



Board of Public Works Claim Register

Invoice Date Range 05/11/24 - 05/24/24

Account 52310 - Building Materials and Supplies Totals		Invoice 2 Transactions	\$171.04
Account 53510 - Electrical Services			
223 - Duke Energy	26-4th St Garage-elec chgs 03/27/24-04/25/24	05/15/2024	608.68
223 - Duke Energy	26-Electric Charges 320 S College Ave 04/02/24-05/01/24	05/15/2024	274.90
223 - Duke Energy	26-Walnut St Garage-300 N Walnut-elec chgs 04/02/24-05/01/24	05/15/2024	995.53
Account 53510 - Electrical Services Totals		Invoice 3 Transactions	\$1,879.11
Account 53610 - Building Repairs			
392 - Koorsen Fire & Security, INC	26-Trades District Gar-annual fire and back flow inspection	BC 2023-089 05/24/2024	181.75
392 - Koorsen Fire & Security, INC	26-Morton St Garage annual fire alarm inspection	BC 2023-089 05/24/2024	214.75
392 - Koorsen Fire & Security, INC	26-Trades Garage-annual fire and backflow inspections	BC 2023-089 05/24/2024	666.93
392 - Koorsen Fire & Security, INC	26-Morton St Gar-quarterly fire alarm monitoring-5/1-7/31/24	BC 2023-089 05/24/2024	150.00
392 - Koorsen Fire & Security, INC	26-4th St Garage-quarterly fire alarm monitoring-5/1-7/31/24	BC 2023-089 05/24/2024	120.00
392 - Koorsen Fire & Security, INC	26-Trades District Gar-quarterly fire alarm monitoring-5/1-7/31	BC 2023-089 05/24/2024	150.00
5239 - Mother Nature Landscaping, INC (Turf N'Tree MD)	26-pruning and rejuvenating red twig dogwoods-4th St Garage	05/24/2024	300.00
8934 - Sierra Heating and Cooling LLC	26-4th St Garage-Spring HVAC servicing period	BC 2023-109 05/24/2024	1,620.00
8934 - Sierra Heating and Cooling LLC	26-Trades District Garage-Spring full service	BC 2023-109 05/24/2024	1,770.00
Account 53610 - Building Repairs Totals		Invoice 9 Transactions	\$5,173.43
Account 53840 - Lease Payments			
512 - 7th & Walnut , LLC	26-Walnut St Garage- June 2024 garage rent	05/24/2024	17,824.79
3887 - Mercury Development Group, LLC	26-Morton St Garage-June 2024 garage rent	05/24/2024	41,706.45
Account 53840 - Lease Payments Totals		Invoice 2 Transactions	\$59,531.24
Account 53990 - Other Services and Charges			
6688 - SSW Enterprises, LLC (Office Pride)	26-627 N Morton-Pkg Services office cleaning 05/01/24	05/24/2024	100.00



Board of Public Works Claim Register

Invoice Date Range 05/11/24 - 05/24/24

Account 53990 - Other Services and Charges Totals		Invoice 1	\$100.00
Program 260000 - Main Totals		Transactions Invoice 20	\$67,228.25
Department 26 - Parking Totals		Transactions Invoice 20	\$67,228.25
Fund 452 - Parking Facilities(S9502) Totals		Transactions Invoice 20	\$67,228.25
Fund 454 - Alternative Transport(S6301)		Transactions	
Department 05 - Common Council			
Program 050000 - Main			
Account 54310 - Improvements Other Than Building			
249 - Crider And Crider, INC	07-CDBG Adams ST Sidewalk Proj-w/ Eng 02/05-04/30/24-App 1	05/24/2024	123,269.00
5818 - Service Solutions of Bloomington (Taycon)	07-Liberty Drive Sidewalk (CN) 02/12-04/18/24-Lump sum	05/24/2024	56,617.00
Account 54310 - Improvements Other Than Building Totals		Invoice 2	\$179,886.00
Program 050000 - Main Totals		Transactions Invoice 2	\$179,886.00
Department 05 - Common Council Totals		Transactions Invoice 2	\$179,886.00
Department 26 - Parking		Transactions	
Program 260000 - Main			
Account 53310 - Printing			
7760 - Western States Envelope Co (4 Lakes Label)	26-parking ticket envelopes (10,000)	05/24/2024	1,348.25
Account 53310 - Printing Totals		Invoice 1	\$1,348.25
Account 53990 - Other Services and Charges		Transactions	
6688 - SSW Enterprises, LLC (Office Pride)	26-627 N Morton-Pkg Services office cleaning 05/01/24	05/24/2024	77.40
204 - State Of Indiana	26-BMV owner information for towing April 2024	05/24/2024	7.50
Account 53990 - Other Services and Charges Totals		Invoice 2	\$84.90
Program 260000 - Main Totals		Transactions Invoice 3	\$1,433.15
		Transactions	



Board of Public Works Claim Register

Invoice Date Range 05/11/24 - 05/24/24

Department 26 - Parking Totals		Invoice 3	\$1,433.15
Fund 454 - Alternative Transport(S6301) Totals		Transactions Invoice 5	\$181,319.15
		Transactions	
Fund 455 - Parking Meter Fund(S2141)			
Department 26 - Parking			
Program 260000 - Main			
Account 52110 - Office Supplies			
8541 - Amazon.com Sales, INC (Amazon.com Services LLC)	26-desk calendar for parking services	05/24/2024	10.21
Account 52110 - Office Supplies Totals		Invoice 1	\$10.21
		Transactions	
Account 52340 - Other Repairs and Maintenance			
3560 - First Financial Bank / Credit Cards	26-Sams Club-food for employees working 2024 eclipse-4/3/24	05/24/2024	135.26
4264 - IPS Group, INC	26-meter clocks returned from IPS after repair (58)	05/24/2024	5,510.00
6172 - The Tamis Corporation	26-50 additional water barricades for special events	05/24/2024	14,200.00
Account 52340 - Other Repairs and Maintenance Totals		Invoice 3	\$19,845.26
		Transactions	
Account 52420 - Other Supplies			
8658 - Kleindorfer's Hardware LLC	26-Hardware to install a Parkmobile sign	05/24/2024	3.04
Account 52420 - Other Supplies Totals		Invoice 1	\$3.04
		Transactions	
Account 52430 - Uniforms and Tools			
4489 - J.L. Waters & Company, INC	26-safety shoes-J. Heath (10.5)-4/30/24	05/24/2024	100.00
Account 52430 - Uniforms and Tools Totals		Invoice 1	\$100.00
		Transactions	
Account 53150 - Communications Contract			
4264 - IPS Group, INC	26-bank fees and communication fees for April 2024	05/24/2024	9,075.00
Account 53150 - Communications Contract Totals		Invoice 1	\$9,075.00
		Transactions	
Account 53240 - Freight / Other			



Board of Public Works Claim Register

Invoice Date Range 05/11/24 - 05/24/24

4264 - IPS Group, INC	26-meter clocks returned from IPS after repair (58)	05/24/2024	1,061.20
	Account 53240 - Freight / Other Totals	Invoice 1	<u>\$1,061.20</u>
Account 53310 - Printing		Transactions	
7760 - Western States Envelope Co (4 Lakes Label)	26-parking ticket envelopes (10,000)	05/24/2024	1,348.25
	Account 53310 - Printing Totals	Invoice 1	<u>\$1,348.25</u>
Account 53640 - Hardware and Software Maintenance		Transactions	
54432 - T2 Systems, INC	26-ROVR hits for April 2024	05/24/2024	1,612.65
	Account 53640 - Hardware and Software Maintenance Totals	Invoice 1	<u>\$1,612.65</u>
Account 53830 - Bank Charges		Transactions	
4264 - IPS Group, INC	26-bank fees and communication fees for April 2024	05/24/2024	5,378.10
	Account 53830 - Bank Charges Totals	Invoice 1	<u>\$5,378.10</u>
Account 53990 - Other Services and Charges		Transactions	
6688 - SSW Enterprises, LLC (Office Pride)	26-627 N Morton-Pkg Services office cleaning	05/24/2024	309.60
204 - State Of Indiana	05/01/24 26-BMV owner information for towing April 2024	05/24/2024	7.50
	Account 53990 - Other Services and Charges Totals	Invoice 2	<u>\$317.10</u>
		Transactions	
	Program 260000 - Main Totals	Invoice 13	<u>\$38,750.81</u>
		Transactions	
	Department 26 - Parking Totals	Invoice 13	<u>\$38,750.81</u>
		Transactions	
	Fund 455 - Parking Meter Fund(S2141) Totals	Invoice 13	<u>\$38,750.81</u>
		Transactions	
Fund 456 - MVH Restricted			
Department 20 - Street			
Program 200000 - Main			
Account 52330 - Street, Alley, and Sewer Material			
5149 - E&B Paving, INC	20-10th/Woodhill/Adams-Asphalt for Paving for	BC 2023-093A 05/24/2024	2,052.75
	04/18/24		



Board of Public Works Claim Register

Invoice Date Range 05/11/24 - 05/24/24

5149 - E&B Paving, INC	20-Asphalt for Paving 04/22/24 1011 High Street Pavn Patch	BC 2023-093A	05/24/2024	4,327.44
334 - Irving Materials, INC	20-Concrete for Sidewalk Proj class a stone,-Stone Gate & Smith	BC 2024-012	05/24/2024	922.50
334 - Irving Materials, INC	20-Concrete for Sidewalk Projects clas a stone-3924 E. Stonegate	BC 2024-012	05/24/2024	967.00
334 - Irving Materials, INC	20-Concrete for Sidewalk Projects class a stone-300 E Kenler	BC 2024-012	05/24/2024	555.00
334 - Irving Materials, INC	20-Concrete for Sidewalk Projects class a stone-250 S Washington	BC 2024-012	05/24/2024	478.00
Account 52330 - Street , Alley, and Sewer Material Totals		Invoice 6		<u>\$9,302.69</u>
		Transactions		
Program 200000 - Main Totals		Invoice 6		<u>\$9,302.69</u>
		Transactions		
Department 20 - Street Totals		Invoice 6		<u>\$9,302.69</u>
		Transactions		
Fund 456 - MVH Restricted Totals		Invoice 6		<u>\$9,302.69</u>
		Transactions		
Fund 457 - Digital Equity Fund				
Department 28 - ITS				
Program 280000 - Main				
Account 53990 - Other Services and Charges				
504 - Housing Authority Of The City of Bloomington (BHA)	28- Digital Equity funds Crestmont internet 04/20/- 05/19		05/24/2024	189.56
Account 53990 - Other Services and Charges Totals		Invoice 1		<u>\$189.56</u>
		Transactions		
Program 280000 - Main Totals		Invoice 1		<u>\$189.56</u>
		Transactions		
Department 28 - ITS Totals		Invoice 1		<u>\$189.56</u>
		Transactions		
Fund 457 - Digital Equity Fund Totals		Invoice 1		<u>\$189.56</u>
		Transactions		
Fund 600 - Cumulative Cap Imprv(CIG)(S2379)				
Department 02 - Public Works				
Program 020000 - Main				
Account 52330 - Street , Alley, and Sewer Material				
11243 - Core & Main, LP	20-ADA plates/detectble tile (35/each) for sidewalk ramps		05/24/2024	4,307.45



Board of Public Works Claim Register

Invoice Date Range 05/11/24 - 05/24/24

Account 52330 - Street , Alley, and Sewer Material Totals	Invoice 1	\$4,307.45
	Transactions	
Program 020000 - Main Totals	Invoice 1	\$4,307.45
	Transactions	
Department 02 - Public Works Totals	Invoice 1	\$4,307.45
	Transactions	
Fund 600 - Cumulative Cap Imprv(CIG)(S2379) Totals	Invoice 1	\$4,307.45
	Transactions	

Fund **601 - Cumulative Capital Devlp(S2391)**

Department **02 - Public Works**

Program **020000 - Main**

Account **52330 - Street , Alley, and Sewer Material**

5149 - E&B Paving, INC	20-Hot mix for patching 03/27/24	BC 2023-093A	05/24/2024	184.45
5149 - E&B Paving, INC	20-4th Street-Hot mix for patching 04/01/24	BC 2023-093A	05/24/2024	186.24
5149 - E&B Paving, INC	20-Stands-Hot mix for patching 04/04/24	BC 2023-093A	05/24/2024	178.50
5149 - E&B Paving, INC	20-Mueller-Hot mix for patching 04/15/24	BC 2023-093A	05/24/2024	182.07
5149 - E&B Paving, INC	20-W. 3rd St-Hot mix for patching 04/16/24	BC 2023-093A	05/24/2024	185.64
5149 - E&B Paving, INC	20-Maple-Hot mix for patching 04/17/24	BC 2023-093A	05/24/2024	516.46
5149 - E&B Paving, INC	20-10th/Woodhill/Adams-Asphalt for Paving for 04/18/24	BC 2023-093A	05/24/2024	187.43

Account 52330 - Street , Alley, and Sewer Material Totals	Invoice 7	\$1,620.79
	Transactions	
Program 020000 - Main Totals	Invoice 7	\$1,620.79
	Transactions	
Department 02 - Public Works Totals	Invoice 7	\$1,620.79
	Transactions	

Department **07 - Engineering**

Program **070000 - Main**

Account **54310 - Improvements Other Than Building**

5149 - E&B Paving, INC	07-Morningside DR Greenway (CN) 02/12-05/01/24- App 1	BC 2023-106	05/24/2024	1,425.00
------------------------	---	-------------	------------	----------

Account 54310 - Improvements Other Than Building Totals	Invoice 1	\$1,425.00
	Transactions	



Board of Public Works Claim Register

Invoice Date Range 05/11/24 - 05/24/24

Program 070000 - Main Totals	Invoice 1	\$1,425.00
	Transactions	
Department 07 - Engineering Totals	Invoice 1	\$1,425.00
	Transactions	
Fund 601 - Cumulative Capital Devlp(S2391) Totals	Invoice 8	\$3,045.79
	Transactions	
Fund 730 - Solid Waste (S6401)		
Department 16 - Sanitation		
Program 160000 - Main		
Account 52110 - Office Supplies		
6530 - Office Depot, INC	16-wirting pads and scotch tape	05/24/2024 89.05
	Account 52110 - Office Supplies Totals	Invoice 1 \$89.05
		Transactions
Account 52230 - Garage and Motor Supplies		
4574 - John Deere Financial f.s.b. (Rural King)	16-hand soap and squeegee	05/24/2024 41.98
	Account 52230 - Garage and Motor Supplies Totals	Invoice 1 \$41.98
		Transactions
Account 52420 - Other Supplies		
3560 - First Financial Bank / Credit Cards	16-Sams Club-Food for employees day of Eclipse-4/6/24	05/24/2024 97.64
	Account 52420 - Other Supplies Totals	Invoice 1 \$97.64
		Transactions
Account 52430 - Uniforms and Tools		
793 - Indiana Safety Company, INC	16-gloves for employees-10 gauge palm coated knit XL	05/24/2024 207.20
798 - Winters Associates Promotional Products, INC	16-shirts for employees	05/24/2024 434.86
	Account 52430 - Uniforms and Tools Totals	Invoice 2 \$642.06
		Transactions
Account 53140 - Exterminator Services		
51538 - Economy Termite & Pest Control, INC	16 - bi-monthly pest control-4/22/24	BC 2023-070 05/24/2024 125.00
	Account 53140 - Exterminator Services Totals	Invoice 1 \$125.00
		Transactions
Account 53150 - Communications Contract		



Board of Public Works Claim Register

Invoice Date Range 05/11/24 - 05/24/24

5465 - Emergency Radio Service LLC (ERS-OCI Wireless)	16-monthly radio fees - May 2024		05/24/2024	572.05
Account 53150 - Communications Contract Totals		Invoice 1		<u>\$572.05</u>
Account 53240 - Freight / Other		Transactions		
793 - Indiana Safety Company, INC	16-gloves for employees-10 gauge palm coated knit XL		05/24/2024	20.42
Account 53240 - Freight / Other Totals		Invoice 1		<u>\$20.42</u>
Account 53410 - Liability / Casualty Premiums		Transactions		
8189 - Paragon Asset Recovery Services, LLC (Sedgwick)	16-replace light pole we knocked down-Duke- #C466032533		05/24/2024	5,000.00
Account 53410 - Liability / Casualty Premiums Totals		Invoice 1		<u>\$5,000.00</u>
Account 53540 - Natural Gas		Transactions		
222 - Indiana Gas Co. INC (CenterPoint Energy) (Vectren)	16-Sanitation-gas bill 04/02/24-05/03/24		05/15/2024	148.35
Account 53540 - Natural Gas Totals		Invoice 1		<u>\$148.35</u>
Account 53610 - Building Repairs		Transactions		
6378 - ANN-KRISS, LLC	16-install snow guard along approx 120' of metal roof	BC 2023-064	05/24/2024	2,670.00
321 - Harrell Fish, INC (HFI)	16-Semi annual BFP testing-4/2/24	BC 2023-075	05/24/2024	180.00
Account 53610 - Building Repairs Totals		Invoice 2		<u>\$2,850.00</u>
Account 53920 - Laundry and Other Sanitation Services		Transactions		
19171 - Vestis Group, INC	16-Mat Services - 05/01/2024		05/24/2024	29.70
19171 - Vestis Group, INC	16-Mat Services - 05/08/2024		05/24/2024	29.70
19171 - Vestis Group, INC	16-uniform rental (minus payroll ded)- 05/01/2024		05/24/2024	6.48
19171 - Vestis Group, INC	16-uniform rental (minus payroll ded)- 05/08/2024		05/24/2024	6.48
Account 53920 - Laundry and Other Sanitation Services Totals		Invoice 4		<u>\$72.36</u>
Account 53950 - Landfill		Transactions		
52226 - Hoosier Transfer Station-3140	16-recycling fees-04/16-04/30/2024		05/24/2024	962.60



Board of Public Works Claim Register

Invoice Date Range 05/11/24 - 05/24/24

52226 - Hoosier Transfer Station-3140

16-trash disposal fee-04/16-04/30/24	05/24/2024	15,122.67
Account 53950 - Landfill Totals	Invoice 2	<u>\$16,085.27</u>
	Transactions	

Account **53990 - Other Services and Charges**

1481 - Ivy Tech Community College of Indiana

16-CDL training for Lake and McAlister	05/24/2024	8,720.00
Account 53990 - Other Services and Charges Totals	Invoice 1	<u>\$8,720.00</u>
	Transactions	
Program 160000 - Main Totals	Invoice 19	<u>\$34,464.18</u>
	Transactions	
Department 16 - Sanitation Totals	Invoice 19	<u>\$34,464.18</u>
	Transactions	
Fund 730 - Solid Waste (S6401) Totals	Invoice 19	<u>\$34,464.18</u>
	Transactions	

Fund **800 - Risk Management(S0203)**

Department **10 - Legal**

Program **100000 - Main**

Account **52430 - Uniforms and Tools**

8418 - Chaney's, INC (Chaney's Fashions and Shoes)	10-Safety Shoes-30 employees @ \$100/each	05/24/2024	3,000.00
8613 - Crane's Leather & Shoe Shop, INC	10-Safety Shoes-D. Bitner (11D)-4/27/24	05/24/2024	100.00
8613 - Crane's Leather & Shoe Shop, INC	10-Safety Shoes- E. Lake (11D)-4/26/24	05/24/2024	100.00
8613 - Crane's Leather & Shoe Shop, INC	10-Safety Shoes-I. Drescher (9.5D)-4/26/24	05/24/2024	100.00
8613 - Crane's Leather & Shoe Shop, INC	10-Safety Shoes- J. Sissman (9.5 EE)-4/25/24	05/24/2024	100.00
8613 - Crane's Leather & Shoe Shop, INC	10-safety shoes-J. Forte (7M)-4/24/24	05/24/2024	81.00
8613 - Crane's Leather & Shoe Shop, INC	10-Safety Shoes- J. VanDeventer (13 D)-4/26/24	05/24/2024	100.00
8613 - Crane's Leather & Shoe Shop, INC	10-Safety Shoes- J. Behrman (9M)-4/26/24	05/24/2024	100.00
8613 - Crane's Leather & Shoe Shop, INC	10-Safety Shoes-J. Behrman (11M)-4/26/24	05/24/2024	100.00
8613 - Crane's Leather & Shoe Shop, INC	10-Safety Shoes-L. Armes (11.5EE)-4/29/24	05/24/2024	100.00
8613 - Crane's Leather & Shoe Shop, INC	10-safety shoes-K. Hudson (12M)-4/23/24	05/24/2024	97.50



Board of Public Works Claim Register

Invoice Date Range 05/11/24 - 05/24/24

Account 52430 - Uniforms and Tools Totals		Invoice 11	<u>\$3,978.50</u>
		Transactions	
Account 53130 - Medical			
6091 - Frank L Corns	10-reimb for CDL physical-3/28/24	05/24/2024	100.00
9244 - Jordan Richey	10-reimb for CDL physical-The Little Clinic-3/15/24	05/24/2024	99.00
Account 53130 - Medical Totals		Invoice 2	<u>\$199.00</u>
		Transactions	
Account 53160 - Instruction			
3560 - First Financial Bank / Credit Cards	10 First Aid/CPR Class - Daix, Mosier, Abel, Melwid, Janke, Lile	05/24/2024	266.00
3560 - First Financial Bank / Credit Cards	10-Hazwoper 24 Training - G. Connor	05/24/2024	179.00
Account 53160 - Instruction Totals		Invoice 2	<u>\$445.00</u>
		Transactions	
Account 53990 - Other Services and Charges			
204 - State Of Indiana	10-Driver's license inquiries (31)- 04/30/24	05/24/2024	31.00
Account 53990 - Other Services and Charges Totals		Invoice 1	<u>\$31.00</u>
		Transactions	
Program 100000 - Main Totals		Invoice 16	<u>\$4,653.50</u>
		Transactions	
Department 10 - Legal Totals		Invoice 16	<u>\$4,653.50</u>
		Transactions	
Fund 800 - Risk Management(S0203) Totals		Invoice 16	<u>\$4,653.50</u>
		Transactions	
Fund 801 - Health Insurance Trust			
Department 12 - Human Resources			
Program 120000 - Main			
Account 53990 - Other Services and Charges			
18539 - Life Insurance Company Of North America	12-May 2024, Bill Ref # 103094_05/01/2024	05/24/2024	4,030.50
Account 53990 - Other Services and Charges Totals		Invoice 1	<u>\$4,030.50</u>
		Transactions	
Account 53990.1278 - Other Services and Charges Disability LTD			
18539 - Life Insurance Company Of North America	12-May 2024, Bill Ref # 103094_05/01/2024	05/24/2024	10,846.08



Board of Public Works Claim Register

Invoice Date Range 05/11/24 - 05/24/24

Account **53990.1278 - Other Services and Charges Disability LTD** Totals

Invoice 1 \$10,846.08

Program **120000 - Main** Totals

Transactions
Invoice 2 \$14,876.58

Department **12 - Human Resources** Totals

Transactions
Invoice 2 \$14,876.58

Fund **801 - Health Insurance Trust** Totals

Transactions
Invoice 2 \$14,876.58

Transactions

Fund **802 - Fleet Maintenance(S9500)**

Department **17 - Fleet Maintenance**

Program **170000 - Main**

Account **52230 - Garage and Motor Supplies**

50605 - Bauer Built, INC	17 - Disposal fee for commercial and light truck's tires		05/24/2024	82.75
50605 - Bauer Built, INC	17 - tires for stock - 4/29/24		05/24/2024	3,998.10
50605 - Bauer Built, INC	17 - tires for stock - 4/9/24		05/24/2024	5,888.09
4693 - Monroe County Tire & Supply, INC	17 - P215/55R16 Firestone all season tire for 848		05/24/2024	102.90
4693 - Monroe County Tire & Supply, INC	17 - LT225/75R16 Firestone Transforce HT2 tire for 814		05/24/2024	136.87
4693 - Monroe County Tire & Supply, INC	17 -(2) 215/75R17.5 Goodride CR960A Reg Steer tires for 467		05/24/2024	330.50

Account **52230 - Garage and Motor Supplies** Totals

Invoice 6 \$10,539.21

Transactions

Account **52240 - Fuel and Oil**

613 - Hoosier Penn Oil Company, INC	17 - handi clean, blue wdshld cleaner, & oil for various equip		05/24/2024	709.23
613 - Hoosier Penn Oil Company, INC	17 - Hyd oils for various vehicles and equipment		05/24/2024	1,969.19
7854 - Premier AG CO-OP, INC (Premier Energy)	17-diesel-B20 PDX4 Clear on Road (7,278 gallons- 5/3/24	BC 2023-105B	05/24/2024	23,168.79
7854 - Premier AG CO-OP, INC (Premier Energy)	17 - unleaded fuel (8,033 gallons)- 4/26/2024	BC 2023-105B	05/24/2024	27,359.59
7854 - Premier AG CO-OP, INC (Premier Energy)	17 - unleaded fuel (8,038 gallons) - 4/26/24	BC 2023-105B	05/24/2024	27,376.62

Account **52240 - Fuel and Oil** Totals

Invoice 5 \$80,583.42

Transactions

Account **52320 - Motor Vehicle Repair**



Board of Public Works Claim Register

Invoice Date Range 05/11/24 - 05/24/24

8541 - Amazon.com Sales, INC (Amazon.com Services LLC)	17 - 963 sensor pressure switch	05/24/2024	164.98
244 - Bloomington Ford, INC	17 - oil cooler tube for 124	05/24/2024	121.00
244 - Bloomington Ford, INC	17 - (2)seal cover assembly, seat cushion pad & pad for 690	05/24/2024	645.23
244 - Bloomington Ford, INC	17 - #634 repairs for no crank and no start	05/24/2024	3,890.66
941 - Central Indiana Truck Equipment Corporation	17 - 5000 pin for 956	05/24/2024	125.32
941 - Central Indiana Truck Equipment Corporation	17 - Illuminated pushbutton red for 957	05/24/2024	183.93
455 - Industrial Service & Supply, INC	17 - rod wiper, polyseals, orings piston seals, 90 deg f/f x ORB	05/24/2024	284.06
11672 - Jack Doheny Companies, INC	17 - WY-water pump 2 spd, w/sealed mtr & belt splice hdwre kit	05/24/2024	1,016.62
11672 - Jack Doheny Companies, INC	17 - Chevron belt for 467	05/24/2024	2,740.49
4439 - JX Enterprises, INC	17 - brake valve for 485	05/24/2024	145.99
6262 - Koenig Equipment, INC	17 - #4831 oil (3 quarts)	05/24/2024	24.66
2974 - MacAllister Machinery Co, INC	17 - 2nd scaper - 4/12/24	05/24/2024	186.11
53385 - O'Reilly Automotive Stores, INC	17 - Air filter for 543	05/24/2024	16.13
53385 - O'Reilly Automotive Stores, INC	17 - nitrile gloves for shop-1 box	05/24/2024	28.49
53385 - O'Reilly Automotive Stores, INC	17 - 1 gal of car wash, 8" brush & washbrush for carwash - shop	05/24/2024	36.96
53385 - O'Reilly Automotive Stores, INC	17 - battery + core charge for 645	05/24/2024	136.49
53385 - O'Reilly Automotive Stores, INC	17 - oil pump for 124	05/24/2024	151.92
53385 - O'Reilly Automotive Stores, INC	17 - engine mount, radiator, torque & trans mount &(2) CV shifts	05/24/2024	564.40
6889 - Professional Golfcar Corporation	17 - #824 spindles and tie rods	05/24/2024	731.90
476 - Southern Indiana Parts, INC (Napa Auto Parts)	17 - repair parts/stocks for the month of April 2024	05/24/2024	6,401.60
5333 - Total Truck Parts, INC	17 - Stock mud flaps (20)	05/24/2024	480.00
484 - Uebelhor & Sons Chevrolet Cadillac Jasper, INC	17 - #627 booster, pump, and seal	05/24/2024	1,374.03
7555 - VoMac Truck Sales & Service INC	17 - Air dryer, core deposit #961	05/24/2024	715.69



Board of Public Works Claim Register

Invoice Date Range 05/11/24 - 05/24/24

2096 - West Side Tractor Sales CO.	17 - nuts for #664		05/24/2024	54.07
2096 - West Side Tractor Sales CO.	17 - filter elements, oil filter, seal & Air filters for 650		05/24/2024	305.59
2096 - West Side Tractor Sales CO.	17 - filters & elements for 4831		05/24/2024	773.33
Account 52320 - Motor Vehicle Repair Totals			Invoice 26	<u>\$21,299.65</u>
			Transactions	
Account 52420 - Other Supplies				
177 - Indiana Oxygen Company, INC	17 - gas for torches-April 2024		05/24/2024	288.90
4574 - John Deere Financial f.s.b. (Rural King)	17 - sawzall quick change w/case, clear tubing		05/24/2024	132.98
8181 - Lawson Products, INC	17 -misc parts & shop supplies-connects, washers, fittinas. scre		05/24/2024	731.86
6216 - Terminal Supply, INC	17 - Cryo-tech drill bits		05/24/2024	139.08
Account 52420 - Other Supplies Totals			Invoice 4	<u>\$1,292.82</u>
			Transactions	
Account 53540 - Natural Gas				
222 - Indiana Gas Co. INC (CenterPoint Energy) (Vectren)	17-Fleet Maint-gas bill 04/04/24-05/07/24		05/15/2024	244.80
Account 53540 - Natural Gas Totals			Invoice 1	<u>\$244.80</u>
			Transactions	
Account 53610 - Building Repairs				
6378 - ANN-KRISS, LLC	17-repair holes in fencing on exterior line at Fleet Maint	BC 2023-065	05/24/2024	1,480.00
392 - Koorsen Fire & Security, INC	17-Fleet-Quarterly Commercial Base Monitoring- 5.1.- 7.31.24	BC 2023-089	05/24/2024	91.27
Account 53610 - Building Repairs Totals			Invoice 2	<u>\$1,571.27</u>
			Transactions	
Account 53620 - Motor Repairs				
6001 - Bernath, LLC (Sealmaster)	17 - #493 repair of electrical issues-burner controller wires		05/24/2024	714.71
244 - Bloomington Ford, INC	17 - #634 repairs for no crank and no start		05/24/2024	2,380.00
4474 - Ken's Westside Service & Towing, LLC	17 - Replace tire with spare Tire-Unit P138-4/26/24		05/24/2024	75.00
4474 - Ken's Westside Service & Towing, LLC	17-tow-Unit #126-5/4/24		05/24/2024	120.00
54351 - Sternberg, INC	17 - #429 repairs to actuator and maintenance		05/24/2024	6,799.99



Board of Public Works Claim Register

Invoice Date Range 05/11/24 - 05/24/24

2096 - West Side Tractor Sales CO.	17 - #617- 500 hour service-4/10/24	05/24/2024	1,729.00
Account 53620 - Motor Repairs Totals		Invoice 6 Transactions	<u>\$11,818.70</u>
Account 53920 - Laundry and Other Sanitation Services			
19171 - Vestis Group, INC	17 - City portion Of uniform rentals - 5/1/2024	05/24/2024	27.13
19171 - Vestis Group, INC	17 - mat and towel rentals - 4/24/24	05/24/2024	93.35
19171 - Vestis Group, INC	17 - mat and towel rentals - 5/1/2024	05/24/2024	93.35
19171 - Vestis Group, INC	17 - City portion Of uniform rentals - 4/24/2024	05/24/2024	27.13
Account 53920 - Laundry and Other Sanitation Services Totals		Invoice 4 Transactions	<u>\$240.96</u>
Account 53990 - Other Services and Charges			
3560 - First Financial Bank / Credit Cards	17 - title fees for City vehicle 508	05/24/2024	15.00
Account 53990 - Other Services and Charges Totals		Invoice 1 Transactions	<u>\$15.00</u>
Program 170000 - Main Totals		Invoice 55 Transactions	<u>\$127,605.83</u>
Department 17 - Fleet Maintenance Totals		Invoice 55 Transactions	<u>\$127,605.83</u>
Fund 802 - Fleet Maintenance(S9500) Totals		Invoice 55 Transactions	<u>\$127,605.83</u>
Fund 804 - Insurance Voluntary Trust			
Department 12 - Human Resources			
Program 120000 - Main			
Account 53990.1271 - Other Services and Charges Section 125 - URM- City			
17785 - The Howard E. Nyhart Company, INC	12-City/Util URM	05/13/2024	40.00
17785 - The Howard E. Nyhart Company, INC	12-City URM	05/13/2024	500.00
17785 - The Howard E. Nyhart Company, INC	12-City/Util URM	05/13/2024	655.88
17785 - The Howard E. Nyhart Company, INC	12-City URM	05/14/2024	35.88
17785 - The Howard E. Nyhart Company, INC	12-City/Util URM	05/15/2024	248.03



Board of Public Works Claim Register

Invoice Date Range 05/11/24 - 05/24/24

17785 - The Howard E. Nyhart Company, INC	12-City URM	05/16/2024	312.24
Account 53990.1271 - Other Services and Charges Section 125 - URM- City Totals		Invoice 6	<u>\$1,792.03</u>
Account 53990.1273 - Other Services and Charges Term Life		Transactions	
18539 - Life Insurance Company Of North America	12-May 2024, Bill Ref # 103094_05/01/2024	05/24/2024	10,386.52
Account 53990.1273 - Other Services and Charges Term Life Totals		Invoice 1	<u>\$10,386.52</u>
Account 53990.1277 - Other Services and Charges Disability STD		Transactions	
18539 - Life Insurance Company Of North America	12-May 2024, Bill Ref # 103094_05/01/2024	05/24/2024	20,518.83
Account 53990.1277 - Other Services and Charges Disability STD Totals		Invoice 1	<u>\$20,518.83</u>
Account 53990.1281 - Other Services and Charges Section 125 - URM- Util		Transactions	
17785 - The Howard E. Nyhart Company, INC	12-City/Util URM	05/13/2024	265.69
17785 - The Howard E. Nyhart Company, INC	12-City/Util URM	05/13/2024	510.96
17785 - The Howard E. Nyhart Company, INC	12-City/Util URM	05/15/2024	49.00
Account 53990.1281 - Other Services and Charges Section 125 - URM- Util Totals		Invoice 3	<u>\$825.65</u>
Account 53990.1283 - Other Services and Charges Health Savings Account		Transactions	
17785 - The Howard E. Nyhart Company, INC	12-HSA Employee Contributions 5-17-2024	05/16/2024	26,797.54
Account 53990.1283 - Other Services and Charges Health Savings Account Totals		Invoice 1	<u>\$26,797.54</u>
Program 120000 - Main Totals		Transactions	
Department 12 - Human Resources Totals		Invoice 12	<u>\$60,320.57</u>
Fund 804 - Insurance Voluntary Trust Totals		Transactions	
		Invoice 12	<u>\$60,320.57</u>
		Transactions	
Fund 805 - Unemployment Comp Non-Reverting			
Department 12 - Human Resources			
Program 120000 - Main			
Account 51240 - Unemployment Compensation			



Board of Public Works Claim Register

Invoice Date Range 05/11/24 - 05/24/24

204 - State Of Indiana

12-May 2024 Unemployment Bill-City portion	05/24/2024	1,470.04
Account 51240 - Unemployment Compensation Totals	Invoice 1	<u>\$1,470.04</u>
	Transactions	
Program 120000 - Main Totals	Invoice 1	<u>\$1,470.04</u>
	Transactions	
Department 12 - Human Resources Totals	Invoice 1	<u>\$1,470.04</u>
	Transactions	
Fund 805 - Unemployment Comp Non-Reverting Totals	Invoice 1	<u>\$1,470.04</u>
	Transactions	

Fund **987 - Econ Dev LIT Bonds of 2022**

Department **06 - Controller's Office**

Program **08FIR1 - Fire Station 1**

Account **54510 - Other Capital Outlays**

3903 - Electric Plus, INC

08-FS#1 Construction Project-Pay App #4 BC 2023-081 05/24/2024 23,410.09

18844 - First Financial Bank, N.A.

08-HFI-FS#1 Construction Proj-#004322-Pay App 4 05/24/2024 6,854.12

10745 - Fox Construction Company, INC

08-FS#1 Construction Project-Pay App 5 BC 2023-078 05/24/2024 327,218.95

321 - Harrell Fish, INC (HFI)

08-FS#1 Construction Project-Project 004322-Pay App BC 2023-080 05/24/2024 130,228.38

4 Account **54510 - Other Capital Outlays** Totals Invoice 4 \$487,711.54

Transactions Invoice 4 \$487,711.54

Program **08FIR1 - Fire Station 1** Totals Invoice 4 \$487,711.54

Transactions Invoice 4 \$487,711.54

Department **06 - Controller's Office** Totals Invoice 4 \$487,711.54

Transactions Invoice 4 \$487,711.54

Fund **987 - Econ Dev LIT Bonds of 2022** Totals Invoice 4 \$487,711.54

Transactions Invoice 4 \$487,711.54

Grand Totals Invoice 372 \$6,050,264.17

Transactions

REGISTER OF CLAIMS
Board of Public Works Claim Register

Date:	Type of Claim	FUND	Description	Bank Transfer	Amount
05/24/24	Claims				\$6,050,264.17
					<u>\$6,050,264.17</u>

ALLOWANCE OF CLAIMS

We have examined the claims listed on the foregoing register of claims, consisting of claims, and except for the claims not allowed as shown on the register, such claims are hereby allowed in the total amount of \$6,050,264.17

Dated this 21st day of May year of 2024.

Kyla Cox Deckard, President	Elizabeth Karon, Vice President	James Roach, Secretary

I hereby certify that each of the above listed voucher(s) or bill(s) is (are) true and correct and I have audited same in accordance with IC 5-11-10-1.6.

Fiscal Office _____