

Board of Public Works Meeting

September 10, 2024



The City will offer virtual options, including CATS public access television (live and tape-delayed) and

Public comments and questions will be encouraged via Zoom or bloomington.in.gov rather than in person

The City is committed to providing equal access to information. However, despite our efforts, at times, portions of our board and commission packets are not accessible for some individuals. If you encounter difficulties accessing material in this packet, please contact April Rosenberger at april.rosenberger@bloomington.in.gov and provide your name, contact information, and a link to or description of the document or web page you are having problems with.

AGENDA
BOARD OF PUBLIC WORKS
September 10, 2024

A Regular Meeting of the Board of Public Work will be held **Tuesday, September 10, 2024 at 5:30 p.m.** in the Council Chambers (RM# 115) of City Hall at the Showers Building, 401 N. Morton Street, Bloomington, Indiana and via Zoom by using the following link

<https://bloomington.zoom.us/j/87835693155?pwd=UzHfSmDlXTD8ceHoKvmmBcte69ATIH.1>

Meeting ID: 878 3569 3155 Passcode: 718158

I. MESSAGES FROM BOARD MEMBERS

II. PETITIONS AND REMONSTRANCES

III. CONSENT AGENDA

1. Resolution 2024-061; Renew Mobile Vendor; Kona Ice Truck #1
2. Resolution 2024-062; Renew Mobile Vendor; Kona Ice Truck #2
3. Resolution 2024-063; Renew Mobile Vendor; Kona Ice Truck #3
4. Approval of Payroll

IV. NEW BUSINESS

1. Addendum 4 to Preliminary Engineering Contract with WSP USA for Neighborhood Greenway Projects
2. Road and Sidewalk Closure Request from Strauser Construction, Inc. on N. Grant Street
3. Road Closures Request from Economic & Sustainable Development in Near West Side Neighborhood
4. Lane and Sidewalk Closure Request from AEG
5. Contract with Multi-Craft for Fire Lines Replacement at Walnut Street Garage

V. STAFF REPORTS & OTHER BUSINESS

VI. APPROVAL OF CLAIMS

VII. ADJOURNMENT

The City is committed to providing equal access to information. However, despite our efforts, at times, portions of our board and commission packets are not accessible for some individuals. If you encounter difficulties accessing material in this packet, please contact April Rosenberger, Public Works Departmental Accessibility contact at april.rosenberger@bloomington.in.gov or 812.349.3411 and provide your name, contact information, and a link to or description of the document or web page you are having problems with.

The City offers virtual options, including CATS public access television (live and tape- delayed). Comments and questions will be encouraged via Zoom or bloomington.in.gov rather than in person.

Auxiliary aids for people with disabilities are available upon request with adequate notice. Please call 812.349.3411 or email public.works@bloomington.in.gov

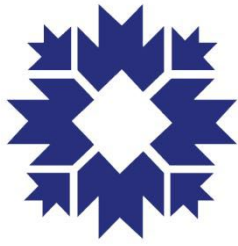

**CITY OF
BLOOMINGTON**
ECONOMIC AND SUSTAINABLE DEVELOPMENT

Project/Event: Mobile Vendor in Right of Way
PW Resolution No: 2024-061
Petitioner/Representative: Warren Stohler, Owner of Kona Ice of
Bloomington - Truck 1
Staff Representative: Susan Coates
Meeting Date: 09/10/2024

Kona Ice of Bloomington - Truck 1, by its owner, Warren Stohler, has applied for a Mobile Vendor License to operate a food truck/trailer. An applicant wanting to operate in the right of way must obtain permission from the Board of Public Works before a license may be issued. The Department of Economic & Sustainable Development has reviewed the application and will confirm that all rules and regulations have been met prior to issuing a license.

The business will be selling food via a mobile kitchen, food truck or trailer.

This application is for 1 year.

Staff is supportive of the request.

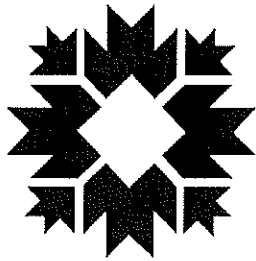

CITY OF BLOOMINGTON

ECONOMIC AND SUSTAINABLE DEVELOPMENT

Business License Cover Sheet

Business Name	Kona Ice of Bloomington - Truck 1
License Type	Mobile Vendor License
Contact	Warren Stohler
Phone	317-363-7810
Email	wstohler@kona-ice.com
BPW Resolution No (if applicable)	2024-061
Issue Date of License	9/12/2024
Expiration Date of License	9/12/2025
Scanned?	<input checked="" type="checkbox"/>
Renewal Date for License	9/12/2025
Department Head	Jane Kupersmith
Record Destruction Date	9/12/2028
ESD Tracking No	N/A
Document Physical Filing Location	2-drawer file cabinet at ESD Admin's desk
Document Digital Filing Location	I:\common\Economic Development\BUSINESS\Business Licensing\Licenses\Mobile Vendor License\Businesses

Truck 1



CITY OF BLOOMINGTON

MOBILE VENDOR LICENSE APPLICATION

City of Bloomington
Department of Economic and Sustainable Development
401 N. Morton St. Suite 150
Bloomington, Indiana 47404
812-349-3418

1. License Length and Fee Application

Length of License: 1 Year - \$350

pd 9/3/24
CK# 1063

2. Applicant Information

Name:	WARREN STOHLER		
Title/Position:	OWNER / OPERATOR		
Date of Birth:	10/02/1953		
Address:	4610 Hacker Creek Rd		
City, State, Zip:	MARTINSVILLE, IN 46151		
E-Mail Address:	WSTOHLER@KONA-ICE.COM		
Phone Number:	317-363-7810	Mobile Phone:	765-610-5934

3. Indiana Contact Information (For non-residents only)

If applicant is not a resident of Indiana, they must designate a resident to serve as a contact.

Name:	NA		
Address:	NA		
City, State, Zip:	NA		
E-Mail Address:			
Phone Number:		Mobile Phone:	

4. Company Information

Name of Employer:	KONA ICE OF BLOOMINGTON		
Address of Employer:	4610 Hacker Creek Rd		
City, State, Zip:	MARTINSVILLE IN 46151		
Employment Start Date:	June 2016	End Date (If known):	TO DATE
Phone Number:	317-363-7810		
Website / Email:	KONA-ICE.COM		
Company is a:	<input checked="" type="checkbox"/> Limited Liability Corporation (LLC)	<input type="checkbox"/> Corporation	<input type="checkbox"/> Partnership
		<input type="checkbox"/> Sole Proprietor	<input type="checkbox"/> Other:

5. Company Officer Information

Provide the names and addresses of all principal officers, partners, trustees, owners or other persons with controlling interests in the company.

Name	Address
WARREN STOHLER	4610 Hacker Creek Rd 46151
DEBBIE STOHLER	4610 Hacker Creek Rd 46151

6. Company Incorporation Information (For Corporations and LLCs Only)

Date of incorporation or organization:	June 2016
State of incorporation or organization:	INDIANA
(If Not Indiana) Date qualified to transact business in state of Indiana:	

7. Description of product or service to be sold and any equipment to be used

Planned hours of operation:	<i>Sun up to Sun down ANY SCHEDULED EVENT</i>
Place or places where you will conduct business (If private property, attach written permission from property owner):	
Scaled site plan showing the location of the proposed mobile food vendor unit and the properties' drives, parking access aisles, fire lanes, sidewalks and accessible routes.	Please Attach
Have you had a similar license, either from the City of Bloomington, or a different municipality, revoked?	Yes <input type="checkbox"/> No <input checked="" type="checkbox"/>
(If Yes) Provide details	

Res. 2024-061

8. You are required to secure, attach, and submit the following:

<input checked="" type="checkbox"/>	A copy of the Indiana registration for the vehicle
<input checked="" type="checkbox"/>	Copy of a valid driver's license
<input checked="" type="checkbox"/>	Copy of an Indiana Driver's Record and/or equivalent of whatever State has issued the applicant his/her driver's license
<input checked="" type="checkbox"/>	Proof of an independent safety inspection of all vehicles to be used in the business (form included with app)
<input checked="" type="checkbox"/>	Proof of insurance in accordance with the limits described in Section 4.28.090 of the Bloomington Municipal Code: <ul style="list-style-type: none">• Personal Injury: \$100,000.00 per occurrence and \$300,000 in the aggregate• Property Damage: \$25,000.00 per occurrence and \$50,000.00 in the aggregate
<input checked="" type="checkbox"/>	Release of liability wherein the Applicant agrees to indemnify and hold harmless the City of Bloomington for losses or expenses arising out of the operation of his/her business (included with application)
<input checked="" type="checkbox"/>	A copy of the business's registration with the Indiana Secretary of State.
<input checked="" type="checkbox"/>	A copy of the Employer ID number
<input checked="" type="checkbox"/>	A signed copy of the Prohibited Location Agreement (included with application)
<input checked="" type="checkbox"/>	A signed copy of the Standards of Conduct Agreement (included with application)
<input type="checkbox"/>	Fire inspection (if required)
<input checked="" type="checkbox"/>	Picture of truck or trailer
<input checked="" type="checkbox"/>	Copy of all applicable permits required by the Monroe County Health Department, including but not limited to a Food Service Establishment License or a Certified Food Handler License.

For City of Bloomington Use Only

Date Received: SEP 03 2024	Received By: <i>[Signature]</i>	Date Approved: 9/11/24	Approved By: <i>[Signature]</i>
-------------------------------	------------------------------------	---------------------------	------------------------------------



State Form 48099 (RS/7-17)
Approved by State Board of
Accounts 2017

INDIANA CERTIFICATE OF VEHICLE REGISTRATION

CLASS 13	AGE 8	ISSUE DATE 01/30/24	PUR DATE 06/27/16	COUNTY 55 - MORGAN	TP R	PL YR 24	PLATE XQJ527	PL TP SP	WEIGHT 11	PR YR 23	LS N	TYPE SP	PRIOR YR PL XQJ527
EXPIRATION DATE 01/31/25	MUNICIPALITY NONE OF THE ABOVE			VEHICLE YEAR 16	MAKE CHE	MODEL EXP	VEHICLE IDENTIFICATION NUMBER 1GB0GRFF6G1279927			TYPE VA	COLOR BLU/		
CURRENT YEAR TAX	EX TAX 50.00	EX CREDIT 0.00	DAV CREDIT 0.00	NET EX TAX 50.00	CO. WHEEL/SUR 25.00	MUN. WHEEL/SUR 0.00	STATE REG FEE 45.35	ADMIN FEE 0.00	TOTAL 120.35				
PRIOR YEAR TAX	EX TAX 0.00	EX CREDIT 0.00	DAV CREDIT 0.00	NET EX TAX 0.00	CO. WHEEL/SUR 0.00	MUN. WHEEL/SUR 0.00	STATE REG FEE 0.00	ADMIN FEE 0.00	TOTAL 0.00				
REGISTRATION LICENSE TYPE IN GOD WE TRUST NEW FORMAT HIGH DIGIT TRUCK 11,000													

INSTRUCTIONS FOR APPLYING PLATE DECAL

1. Verify plate number and decal match.
2. Do not attempt to apply decal if temperature is below -10 degrees Fahrenheit.
3. Clean and dry plate before affixing new decal.
4. Remove decal by bending corner of card under decal along dotted line.
5. Next, lift up corner of decal where card is creased.
6. Decal is fragile peel decal off slowly.
7. Place decal in the upper right corner of your license plate.
8. Rub or press firmly around edges of decal after application.



Legal Address
4610 HACKER CREEK RD
MARTINSVILLE IN 46151-9433

STOHLER PROPERTY MANAGEMENT LL



0102

**4610 HACKER CREEK RD
MARTINSVILLE IN 46151-9433**



000.00.000

PEEL



REGISTERED RETAIL MERCHANT CERTIFICATE

INDIANA DEPARTMENT OF REVENUE
100 N SENATE AVE
INDIANAPOLIS IN 46204-2253
(317) 232-2240

KONA ICE OF BLOOMINGTON INCORPORATED
4610 HACKER CREEK RD
MARTINSVILLE IN 46151-9433

FEIN 81-2690958
LOC ID 0158439155-001
ISSUED December 02, 2021
EXPIRES December 31, 2023

IS AUTHORIZED TO COLLECT INDIANA RETAIL SALES TAX AT THE ADDRESS ABOVE IF DIFFERENT FROM BELOW.

THIS LICENSE:
IS NOT TRANSFERRABLE TO ANY OTHER PERSON.
IS NOT SUBJECT TO REBATE.
IS VOID IF ALTERED.

KONA ICE OF BLOOMINGTON INCORPORATED
4610 HACKER CREEK RD
MARTINSVILLE IN 46151-9433

Robert J. Gennaro

COMMISSIONER

MUST BE DISPLAYED BY MERCHANT IN THE LOCATION SHOWN

Background Verification Report

REQUESTED: 8/14/2024

PRINTED: 8/26/2024 12:01:25 PM

COMPLETED: 8/14/2024

APPLICANT INFORMATION

PROVIDED TO: Kona Ice of Bloomington

REQUESTED BY: Warren Stohler

ATTENTION: Kona Ice of Bloomington

PROVIDED BY: AUDI LLC

SUBJECT: STOHLER, WARREN E

SS #: XXX-XX-6423

ADDRESS: 4610 HACKER CREEK RD
MARTINSVILLE, IN 46151

DOB: 10/02/1953

RESULTS DETAILS

DRIVING HISTORY

Driver's License #: 8914850785

State Issued: IN

Reported Driver's License #: 8914850785

INDIANA DRIVER RECORD REPORT

REPORT SEARCH DATE -> 08/14/2024

LICENSE NAME/ADDRESS

DRIVER DESCRIPTION

STOHLER, WARREN EDWARD
4610 HACKER CREEK RD
MARTINSVILLE, IN 46151-9433

DOB/SS# | GENDER/RACE | HT/WT | EYES/H
===== | ===== | ===== | ===== | =====
10/02/53 | M | 511 | BLUE |
| | 195 | GRAY |

LICENSE NUMBER	ORIG. ISSUED	ISSUED	EXPIRES	CLASS	STATUS
8914850785		11/01/2019	10/02/2026	OPERATOR	VALID (DUPL)

POINTS: 0
LIC TYP: PERSONAL
STATUS: VALID (DUPLICATE LICENSE)
RESTRICTIONS: CORRECTIVE LENSES
ENDORSEMENTS: FOR HIRE - NON-CMV ONLY

*** MISCELLANEOUS AND STATE SPECIFIC INFORMATION ***

** REINSTATEMENT FEE: \$0.00
** NO INSURANCE FEE: \$0.00

- ** OR LEGISLATIVE ACTION OF THE ISSUING JURISDICTION RELATED TO COVID-19.
- ** PLEASE CONSULT WITH THE JURISDICTION FOR FURTHER DETAILS.
- ** MAILING 4610 HACKER CREEK RD MARTINSVILLE IN 46151-9433
- ** MAILING 4610 HACKER CREEK RD MARTINSVILLE IN 46151-9433
- ** MAILING 6280 S 625 W PENDLETON IN 46064-8972
- ** MAILING 6280 S 625 W PENDLETON IN 46064-8972
- ** MAILING 6280 S 625 W PENDLETON IN 46064-8972
- ** MAILING 15 S CREEDMOOR WAY ANDERSON IN 46011-9019
- ** MAILING 15 S CREEDMOOR WAY ANDERSON IN 46011-9019
- ** MAILING 1777 RACCOON WAY PENDLETON IN 46064-8605

NO REPORTABLE INCIDENTS FOUND

*** DRIVING RECORD HISTORY ***

Type	Viol/Susp	Conv/Reins	Post/Expir	Description	Pts
OTHE	10/03/2019		10/02/2026	PERSONAL Sub Type.....: HISTORICAL LICENSE EN.....: FOR HIRE - NON-CMV ONLY RS.....: CORRECTIVE LENSES Class.....: OPERATOR Record Status.....: VALID (RENEW LICENSE)	
OTHE	08/14/2013		10/02/2019	PERSONAL Sub Type.....: HISTORICAL LICENSE RS.....: CORRECTIVE LENSES Class.....: CHAUFFEUR Record Status.....: EXPIRED (RENEW LICENSE)	
OTHE	10/03/2012		10/02/2016	PERSONAL Sub Type.....: HISTORICAL LICENSE RS.....: CORRECTIVE LENSES Class.....: OPERATOR (4 YEAR) NONPROB Record Status.....: EXPIRED (RENEW CDL LICENSE)	
OTHE	11/27/2010		10/02/2012	COMMERCIAL Sub Type.....: HISTORICAL LICENSE EN.....: PASSENGER TRANSPORT, DOUBLE/TRI RS.....: CORRECTIVE LENSES Class.....: B - VEH GCWR=>26,001 LBS W/TOWE Record Status.....: PENDING (AMEND CDL LICENSE)	
OTHE	10/01/2008		10/02/2012	COMMERCIAL Sub Type.....: HISTORICAL LICENSE EN.....: PASSENGER TRANSPORT, DOUBLE/TRI RS.....: CORRECTIVE LENSES Class.....: B - VEH GCWR=>26,001 LBS W/TOWE Record Status.....: EXPIRED (RENEW CDL LICENSE)	
OTHE	11/21/2006		10/02/2008	COMMERCIAL	

Sub Type.....: HISTORICAL LICENSE
EN.....: PASSENGER TRANSPORT, DOUBLE/TRI
Class.....: B - VEH GCWR=>26,001 LBS W/TOWE
Record Status.....: EXPIRED (AMEND CDL LICENSE)

OTHE 03/02/2004 10/02/2008 COMMERCIAL

Sub Type.....: HISTORICAL LICENSE
EN.....: PASSENGER TRANSPORT, DOUBLE/TRI
RS.....: CORRECTIVE LENSES
Class.....: B - VEH GCWR=>26,001 LBS W/TOWE
Record Status.....: EXPIRED (RENEW LICENSE)

PERM 02/18/2004 08/31/2004 COMMERCIAL PERMIT

Permit Class.....: A - PERMIT FOR COMB VEH GCWR=>2
Permit Status.....: EXPIRED (AMEND CDL LICENSE)
Permit Restrictions.: CORRECTIVE LENSES
Permit Endorsements.: PASSENGER TRANSPORT, DOUBLE/TRI

OTHE 02/16/2004 10/02/2004 PERSONAL

Sub Type.....: HISTORICAL LICENSE
Class.....: OPERATOR
Record Status.....: EXPIRED (DUPLICATE LICENSE)

PERM 02/14/2004 08/31/2004 COMMERCIAL PERMIT

Permit Class.....: B - PERMIT FOR VEH GCWR=>26,001
Permit Status.....: EXPIRED (RENEW CDL PERMIT)
Permit Restrictions.: CORRECTIVE LENSES
Permit Endorsements.: PASSENGER TRANSPORT

OTHE 10/12/2000 10/02/2004 PERSONAL

Sub Type.....: HISTORICAL LICENSE
Class.....: OPERATOR
Record Status.....: EXPIRED (RENEW LICENSE)

OTHE 12/02/1996 10/31/2000 PERSONAL

Sub Type.....: HISTORICAL LICENSE
RS.....: CORRECTIVE LENSES
Class.....: OPERATOR
Record Status.....: EXPIRED (RENEW LICENSE)

*** END OF RECORD ***

08/14/24 07:07:04 AM

DISCLAIMER

Users should consult State and Federal laws before using this information in making decisions on hiring or firing of employees. By requesting any search, you certify that you assume full responsibility for compliance with the legal restrictions, terms of use, and applicable laws. You also agree to use all information provided to you that does not violate the Gramm-Leach-Bliley Act (GLBA), Fair Credit Reporting Act, 15 U.S.C. sec. 1681 et seq., (FCRA), Federal Trade Commission interpretations of the Fair Credit Reporting Act, and similar state statutes.

Permissible Use / Summary of Your Rights Under the Fair Credit Report

Permissible Use

Users should consult State and Federal laws before using this information in making decisions on hiring or firing of employees. By requesting any search, you certify that you assume full responsibility for compliance with the legal restrictions, terms of use, and applicable laws. You also agree to use all information provided to you that does not violate the Gramm-Leach-Bliley Act (GLBA), Fair Credit Reporting Act, 15 U.S.C. sec. 1681 et seq., (FCRA), Federal Trade Commission interpretations of the Fair Credit Reporting Act, and similar state statutes.

Para información en español, visite www.consumerfinance.gov/learnmore o escriba a la Consumer Financial Protection Bureau, 1700 G Street NW, Washington, DC 20552.

A Summary of Your Rights Under the Fair Credit Reporting Act

The federal Fair Credit Reporting Act (FCRA) promotes the accuracy, fairness, and privacy of information in the files of consumer reporting agencies. There are many types of consumer reporting agencies, including credit bureaus and specialty agencies (such as agencies that sell information about check writing histories, medical records, and rental history records).

Here is a summary of your major rights under FCRA. For more information, including information about additional rights, go to www.consumerfinance.gov/learnmore or write to: Consumer Financial Protection Bureau, 1700 G Street NW, Washington, DC 20552.

- You must be told if information in your file has been used against you. Anyone who uses a credit report or another type of consumer report to deny your application for credit, insurance, or employment - or to take another adverse action against you - must tell you, and must give you the name, address, and phone number of the agency that provided the information.

- You have the right to know what is in your file. You may request and obtain all the information about you in the files of a consumer reporting agency (your "file disclosure"). You will be required to provide proper identification, which may include your Social Security number. In many cases, the disclosure will be free. You are entitled to a free file disclosure if:
 - o a person has taken adverse action against you because of information in your

credit report,

- o you are the victim of identity theft and place a fraud alert in your file;
- o your file contains inaccurate information as a result of fraud;
- o you are on public assistance;
- o you are unemployed but expect to apply for employment within 60 days.

In addition, all consumers are entitled to one free disclosure every 12 months upon

request from each nationwide credit bureau and from nationwide specialty consumer reporting agencies. See www.consumerfinance.gov/learnmore for additional information.

- You have the right to ask for a credit score. Credit scores are numerical summaries of your credit-worthiness based on information from credit bureaus. You may request a credit score from consumer reporting agencies that create scores or distribute scores used in residential real property loans, but you will have to pay for it. In some mortgage transactions, you will receive credit score information for free from the mortgage lender.

- You have the right to dispute incomplete or inaccurate information. If you identify information in your file that is incomplete or inaccurate, and report it to the consumer reporting agency, the agency must investigate unless your dispute is frivolous. See www.consumerfinance.gov/learnmore for an explanation of dispute procedures.

- Consumer reporting agencies must correct or delete inaccurate, incomplete, or unverifiable information. Inaccurate, incomplete, or unverifiable information must be removed or corrected, usually within 30 days. However, a consumer reporting agency may continue to report information it has verified as accurate.

- Consumer reporting agencies may not report outdated negative information. In most cases, a consumer reporting agency may not report negative information that is more than seven years old, or bankruptcies that are more than 10 years old.

- Access to your file is limited. A consumer reporting agency may provide information about you only to people with a valid need - usually to consider an application with a creditor, insurer, employer, landlord, or other business. The FCRA specifies those with a valid need for access.

- You must give your consent for reports to be provided to employers. A consumer reporting agency may not give out information about you to your employer, or a potential employer, without your written consent given to the employer. Written consent is not required in the trucking industry. For more information, go to www.consumerfinance.gov/learnmore.

- You may limit "prescreened" offers of credit and insurance you get based on

information in your credit report. Unsolicited prescreened offers for credit and insurance must include a toll-free phone number you can call if you choose to remove your name and address from the lists these offers are based on. You may opt out with the nationwide credit bureaus at 1-800-XXX-XXXX.

- The following FCRA right applies with respect to nationwide consumer reporting agencies:

CONSUMERS HAVE THE RIGHT TO OBTAIN A SECURITY FREEZE

You have a right to place a "security freeze" on your credit report, which will prohibit a consumer reporting agency from releasing information in your credit report without your express authorization. The security freeze is designed to prevent credit, loans, and services from being approved in your name without your consent.

However, you should be aware that using a security freeze to take control over who gets

access to the personal and financial information in your credit report may delay, interfere

with, or prohibit the timely approval of any subsequent request or application you make

regarding a new loan, credit, mortgage, or any other account involving the extension of credit.

As an alternative to a security freeze, you have the right to place an initial or extended

fraud alert on your credit file at no cost. An initial fraud alert is a 1-year alert that is

placed on a consumer's credit file. Upon seeing a fraud alert display on a consumer's

credit file, a business is required to take steps to verify the consumer's identity before

extending new credit. If you are a victim of identity theft, you are entitled to an extended

fraud alert, which is a fraud alert lasting 7 years.

A security freeze does not apply to a person or entity, or its affiliates, or collection

agencies acting on behalf of the person or entity, with which you have an existing

account that requests information in your credit report for the purposes of reviewing or

collecting the account. Reviewing the account includes activities related to account

maintenance, monitoring, credit line increases, and account upgrades and enhancements.

- You may seek damages from violators. If a consumer reporting agency, or, in some

cases, a user of consumer reports or a furnisher of information to a consumer reporting

agency violates the FCRA, you may be able to sue in state or federal court.

- Identity theft victims and active duty military personnel have additional rights. For

States may enforce the FCRA, and many states have their own consumer reporting laws.

In some cases, you may have more rights under state law. For more information, contact

your state or local consumer protection agency or your state Attorney General.

For

information about your federal rights, contact:

information about your federal rights, contact:

4

TYPE OF BUSINESS: CONTACT:

1.a. Banks, savings associations, and credit unions with total assets of over \$10 billion and their affiliates

b. Such affiliates that are not banks, savings associations, or credit unions also should list, in addition to the CFPB:

a. Consumer Financial Protection Bureau

1700 G Street NW

Washington, DC 20552

b. Federal Trade Commission

Consumer Response Center

600 Pennsylvania Avenue NW

Washington, DC 20580

(877) 382-4357

2. To the extent not included in item 1 above:

a. National banks, federal savings associations, and federal branches and federal agencies of foreign banks

b. State member banks, branches and agencies of foreign banks (other than federal branches, federal agencies, and Insured State Branches of Foreign Banks), commercial lending companies owned or controlled by foreign banks, and organizations operating under section 25 or 25A of the Federal Reserve Act.

c. Nonmember Insured Banks, Insured State Branches of Foreign Banks, and insured state savings associations

d. Federal Credit Unions

a. Office of the Comptroller of the Currency

Customer Assistance Group

P.O. Box 53570

Houston, TX 77052

b. Federal Reserve Consumer Help Center

P.O. Box 1200

Minneapolis, MN 55480

c. Division of Depositor and Consumer Protection

National Center for Consumer and Depositor Assistance

Federal Deposit Insurance Corporation

1100 Walnut Street, Box #11

Kansas City, MO 64106

d. National Credit Union Administration

Office of Consumer Financial Protection

1775 Duke Street

Alexandria, VA 22314

3. Air carriers Assistant General Counsel for Office of Aviation Protection

1200 New Jersey Avenue SE

Washington, DC 20590

4. Creditors Subject to the Surface Transportation Board Office of Public Assistance, Governmental Affairs, and Compliance

Surface Transportation Board

395 E Street SW

Washington, DC 20423

5. Creditors Subject to the Packers and Stockyards Act, 1921

Nearest Packers and Stockyards Division Regional Office

6. Small Business Investment Companies Associate Administrator, Office of Capital Access

United States Small Business Administration

409 Third Street SW, Suite 8200

Washington, DC 20416

7. Brokers and Dealers Securities and Exchange Commission

100 F Street NE

Washington, DC 20549

8. Institutions that are members of the Farm Credit System

Farm Credit Administration

1501 Farm Credit Drive

McLean, VA 22102-5090

9. Retailers, Finance Companies, and All Other Creditors Not Listed Above

Federal Trade Commission

Consumer Response Center

600 Pennsylvania Avenue NW

Washington, DC 20580

(877) 382-4357

CITY OF BLOOMINGTON

MOBILE VENDOR INSPECTION CHECK SHEET

COMPANY PERFORMING INSPECTION ARNOLD TIRE Co.
INSPECTOR'S NAME DON ARNOLD INSPECTOR'S PHONE # 765-342-8405
DATE OF INSPECTION 8/15/24
NAME OF VENDOR _____
VEHICLE YEAR 2016 MAKE 3500 CHEVY MODEL EXPRESS VAN
VIN 1GBOGRFF6G1Z79927

	PASS	FAIL	COMMENTS
LIGHTS (Front & Rear)	✓	_____	_____
FLASHERS	✓	_____	_____
REFLECTORS	✓	_____	_____
HORN	✓	_____	_____
WINDSHIELD WIPERS	✓	_____	_____
MIRRORS	✓	_____	_____
SEATBELTS	✓	_____	_____
BUMPER HEIGHT	✓	_____	_____
ALL WINDOWS	✓	_____	_____
MUFFLER	✓	_____	_____
TIRES	✓	_____	_____
BRAKES	✓	_____	<u>Front 80% Rear 80%</u>
DOORS	✓	_____	_____
GENERAL CONDITION OF VEHICLE	✓ <u>GOOD</u>	_____	_____

Attach this completed Inspection Sheet with your permit or renewal application
and remit to:

City of Bloomington
Department of Economic and Sustainable Development
401 N. Morton St.
Bloomington, Indiana 47404
812-349-3419

Additional Comments by Inspector: _____

Inspector Signature *Pa Dubel*

Date: 8-15/24

**Attach this completed Inspection Sheet with your permit or renewal application
and remit to:**

**City of Bloomington
Department of Economic and Sustainable Development
401 N. Morton St.
Bloomington, Indiana 47404
812-349-3419**



CERTIFICATE OF LIABILITY INSURANCE

DATE (MM/DD/YYYY)
09/03/2024

THIS CERTIFICATE IS ISSUED AS A MATTER OF INFORMATION ONLY AND CONFERS NO RIGHTS UPON THE CERTIFICATE HOLDER. THIS CERTIFICATE DOES NOT AFFIRMATIVELY OR NEGATIVELY AMEND, EXTEND OR ALTER THE COVERAGE AFFORDED BY THE POLICIES BELOW. THIS CERTIFICATE OF INSURANCE DOES NOT CONSTITUTE A CONTRACT BETWEEN THE ISSUING INSURER(S), AUTHORIZED REPRESENTATIVE OR PRODUCER, AND THE CERTIFICATE HOLDER.

IMPORTANT: If the certificate holder is an ADDITIONAL INSURED, the policy(ies) must have ADDITIONAL INSURED provisions or be endorsed. If SUBROGATION IS WAIVED, subject to the terms and conditions of the policy, certain policies may require an endorsement. A statement on this certificate does not confer rights to the certificate holder in lieu of such endorsement(s).

PRODUCER Northern Kentucky Insurance 5915 Centennial Circle Florence KY 41042		CONTACT NAME: Amie Turner PHONE (A/C, No, Ext): (859)586-8580 E-MAIL ADDRESS: amie@cornerstoneinsllc.com FAX (A/C, No): (859)586-8616																						
INSURED Kona Ice of Bloomington Inc. 4610 Hacker Creek Rd Martinsville IN 46151		<table border="1"> <tr> <th colspan="2">INSURER(S) AFFORDING COVERAGE</th> <th>NAIC #</th> </tr> <tr> <td>INSURER A :</td> <td>Great American Insurance Company</td> <td>16691</td> </tr> <tr> <td>INSURER B :</td> <td>Great American Assurance Company</td> <td>26344</td> </tr> <tr> <td>INSURER C :</td> <td>Great American Spirit Insurance Company</td> <td>33723</td> </tr> <tr> <td>INSURER D :</td> <td></td> <td></td> </tr> <tr> <td>INSURER E :</td> <td></td> <td></td> </tr> <tr> <td>INSURER F :</td> <td></td> <td></td> </tr> </table>		INSURER(S) AFFORDING COVERAGE		NAIC #	INSURER A :	Great American Insurance Company	16691	INSURER B :	Great American Assurance Company	26344	INSURER C :	Great American Spirit Insurance Company	33723	INSURER D :			INSURER E :			INSURER F :		
INSURER(S) AFFORDING COVERAGE		NAIC #																						
INSURER A :	Great American Insurance Company	16691																						
INSURER B :	Great American Assurance Company	26344																						
INSURER C :	Great American Spirit Insurance Company	33723																						
INSURER D :																								
INSURER E :																								
INSURER F :																								

COVERAGES **CERTIFICATE NUMBER:** 2024-2025 **REVISION NUMBER:**

THIS IS TO CERTIFY THAT THE POLICIES OF INSURANCE LISTED BELOW HAVE BEEN ISSUED TO THE INSURED NAMED ABOVE FOR THE POLICY PERIOD INDICATED. NOTWITHSTANDING ANY REQUIREMENT, TERM OR CONDITION OF ANY CONTRACT OR OTHER DOCUMENT WITH RESPECT TO WHICH THIS CERTIFICATE MAY BE ISSUED OR MAY PERTAIN, THE INSURANCE AFFORDED BY THE POLICIES DESCRIBED HEREIN IS SUBJECT TO ALL THE TERMS, EXCLUSIONS AND CONDITIONS OF SUCH POLICIES. LIMITS SHOWN MAY HAVE BEEN REDUCED BY PAID CLAIMS.

INSR LTR	TYPE OF INSURANCE	ADDL INSD	SUBR WVD	POLICY NUMBER	POLICY EFF (MM/DD/YYYY)	POLICY EXP (MM/DD/YYYY)	LIMITS
A	<input checked="" type="checkbox"/> COMMERCIAL GENERAL LIABILITY <input type="checkbox"/> CLAIMS-MADE <input checked="" type="checkbox"/> OCCUR GEN'L AGGREGATE LIMIT APPLIES PER: <input checked="" type="checkbox"/> POLICY <input type="checkbox"/> PRO-JECT <input type="checkbox"/> LOC OTHER:			BOP3805994	06/29/2024	06/29/2025	EACH OCCURRENCE \$ 2,000,000 DAMAGE TO RENTED PREMISES (Ea occurrence) \$ 500,000 MED EXP (Any one person) \$ 10,000 PERSONAL & ADV INJURY \$ 2,000,000 GENERAL AGGREGATE \$ 4,000,000 PRODUCTS - COMP/OP AGG \$ 4,000,000 \$
B	<input checked="" type="checkbox"/> AUTOMOBILE LIABILITY <input checked="" type="checkbox"/> ANY AUTO <input type="checkbox"/> OWNED AUTOS ONLY <input type="checkbox"/> SCHEDULED AUTOS <input type="checkbox"/> HIRED AUTOS ONLY <input type="checkbox"/> NON-OWNED AUTOS ONLY <input type="checkbox"/> AUTOS ONLY			CAP3805995	06/29/2024	06/29/2025	COMBINED SINGLE LIMIT (Ea accident) \$ 1,000,000 BODILY INJURY (Per person) \$ BODILY INJURY (Per accident) \$ PROPERTY DAMAGE (Per accident) \$ \$
	<input type="checkbox"/> UMBRELLA LIAB <input type="checkbox"/> OCCUR <input type="checkbox"/> EXCESS LIAB <input type="checkbox"/> CLAIMS-MADE DED RETENTION \$						EACH OCCURRENCE \$ AGGREGATE \$ \$
C	<input checked="" type="checkbox"/> WORKERS COMPENSATION AND EMPLOYERS' LIABILITY ANY PROPRIETOR/PARTNER/EXECUTIVE OFFICER/MEMBER EXCLUDED? (Mandatory in NH) If yes, describe under DESCRIPTION OF OPERATIONS below		N/A	WC3805996	06/29/2024	06/29/2025	<input checked="" type="checkbox"/> PER STATUTE <input type="checkbox"/> OTHER E.L. EACH ACCIDENT \$ 1,000,000 E.L. DISEASE - EA EMPLOYEE \$ 1,000,000 E.L. DISEASE - POLICY LIMIT \$ 1,000,000

DESCRIPTION OF OPERATIONS / LOCATIONS / VEHICLES (ACORD 101, Additional Remarks Schedule, may be attached if more space is required)
Certificate holder is listed as an additional insured with regards to the operations of the named insured.

CERTIFICATE HOLDER City of Bloomington 401 North Morton St. Bloomington IN 47404	CANCELLATION SHOULD ANY OF THE ABOVE DESCRIBED POLICIES BE CANCELLED BEFORE THE EXPIRATION DATE THEREOF, NOTICE WILL BE DELIVERED IN ACCORDANCE WITH THE POLICY PROVISIONS. AUTHORIZED REPRESENTATIVE
--	--

Kerry Thomson
Mayor
CITY OF BLOOMINGTON
401 N. Morton St Suite 130
P.O. Box 100
Bloomington, Indiana 47402

DEPARTMENT OF ECONOMIC
& SUSTAINABLE DEVELOPMENT
p. 812.349.3418
f. 812.349.3520

RELEASE, HOLD-HARMLESS AND INDEMNIFICATION AGREEMENT

The undersigned, in consideration for the issuance of a license by the City of Bloomington Controller, agrees to the following:

1. The undersigned, in exchange for the issuance of a license by the City of Bloomington Controller, agrees to release, hold harmless, and forever indemnify the City of Bloomington and any and all City employees, officers, and agents from any claim or claims which may arise out of any incident connected with or in any way related to his/her issuance of a license by the City of Bloomington or his/her operation of a business which was licensed by the City of Bloomington. This includes claims for personal injury, death, property damage, and/or any other type of harm or injury.
2. The undersigned shall, and hereby does, indemnify, defend, and hold harmless the City of Bloomington and any and all City employees, officers, and agents from and against any and all actions, costs, claims, suits, losses, expenses or damages, including but not limited to attorneys' fees and court costs, arising out of the undersigned's operation of a business which has been licensed by the City of Bloomington.
3. The undersigned understands this release binds him/herself, his/her spouse, and all heirs, executors, partners, co-owners and administrators of those individuals.

The undersigned acknowledges that he/she has read this release and understands all of its terms. The undersigned signs this release voluntarily and with full knowledge of its significance.

WARREN STOKER
Name, Printed

Warren Stoker
Signature

AUG 14, 2024
Date Release Signed

Kerry Thomson

Mayor

CITY OF BLOOMINGTON

401 N. Morton St Suite 130

P.O. Box 100

Bloomington, Indiana 47402

**DEPARTMENT OF ECONOMIC
& SUSTAINABLE DEVELOPMENT**

p. 812.349.3418

f. 812.349.3520

Prohibited Location Agreement

Bloomington Municipal Code Section 4.28.140 prohibits Mobile Vendor Units from operating in certain locations. This Agreement provides for all of the prohibited locations. Two maps are also attached to this Agreement. All signatories to this Agreement are required to review not only this Agreement, but also the attached maps prior to signing this Agreement.

As a licensed Mobile Vendor Unit, I understand and agree that I cannot and will not operate my mobile vendor unit in a manner that would violate any of the below-listed location restrictions:

- No mobile food vendor unit shall locate in any parking lot, parking space, or parking facility owned, leased or managed by the City of Bloomington unless approval has been given by the City's Board of Public Works.
- No mobile food vendor unit shall operate within fifty feet of any facade of a ground level establishment that also sells food or beverages, or operate within fifty feet of the perimeter of such an establishment's outdoor seating area, regardless of whether or not the mobile food vendor unit is currently conducting business. The distance restriction only applies from one hour before the opening time to an hour after the closing time posted by a ground level establishment on the facade of its building.
- No mobile food vendor unit shall locate in an alleyway.
- Mobile food vendor units shall be located a reasonable distance from all posted bus stops, crosswalks, driveways, alleyways, right-of-way lines of two or more intersecting streets and building entrances or walk-up windows.
- Mobile food vendor units shall only be located on private property if the private property owner has provided both the business operator and the City written permission for the mobile food vendor unit to locate on said property.
- No mobile food vendor unit shall locate within a one block radius of a Special Event unless prior approval has been granted by either the operator of the Special Event or the City's Board of Public Works.
- No mobile food vendor unit shall park on City property in violation of any City parking regulation, restriction, or ordinance. For example, if parking at one, or multiple, parking meters, the operator of the mobile food vendor unit shall feed all relevant parking meters with the required monetary amount.
- No mobile food vendor unit shall be located in a manner which would significantly impede or prevent the use of any City of Bloomington property, or which would endanger the safety or property of the public.
- No mobile food vendor unit shall be located within fifteen feet of any fire hydrant.

- No mobile food vendor shall locate within any zoning district except the following: Commercial General; Commercial Arterial; Commercial Downtown; Industrial General; Business Park; and Institutional.
- No mobile food vendor operating on private property shall displace required parking or landscaping nor block any drives, parking access aisles, fire lanes, sidewalks, or accessible routes required for the private parking by the City's zoning code.
- No mobile food vendor unit shall be located more than one foot away from the curb of the street on which it is parked.
- No mobile food vendor unit shall park near an intersection and in a manner that blocks the line-of-sight of drivers using adjacent roadways.

I, the undersigned, understand that if I locate my mobile vendor unit in any of the above-described prohibited locations or manner that I subject myself to fines and possible revocation of my Mobile Vendor Unit License, as so described in Chapter 4.28 of the Bloomington Municipal Code.

Vendor:

Name: WARREN STOLLER

Signature: Warren Stoller

Date: AUG 14, 2024

Kerry Thomson

Mayor

CITY OF BLOOMINGTON

401 N. Morton St Suite 130

P.O. Box 100

Bloomington, Indiana 47402

**DEPARTMENT OF ECONOMIC
& SUSTAINABLE DEVELOPMENT**

p. 812.349.3418

f. 812.349.3520

Standard of Conduct Agreement

Bloomington Municipal Code Section 4.28.160 provides Standards of Conduct for all Mobile Vendor Units. This Agreement provides a list of said Standards of Conduct. All signatories to this Agreement are required to review this Agreement prior to signing this Agreement.

As a licensed Mobile Vendor Unit, I understand and agree that I cannot and will not conduct business in a manner that would violate any of the Standards of Conduct noted below:

- Mobile food vendor unit operators shall conduct themselves at all times in an orderly and lawful manner, and shall not make, or cause to be made, any unreasonable noise of such volume as to be in violation of the City of Bloomington Noise Ordinance as stated in Title 14 of the Bloomington Municipal Code
- A device may not be used which would amplify sounds nor may attention be drawn to the mobile food vendor unit by an aural means or a light-producing device (examples of such devices may include, but are not meant to be limited to the following: bull horns and strobe lights
- No mobile food vendor unit may be permanently or temporarily affixed to any object, including but not limited to buildings, trees, telephone poles, streetlight poles, traffic signal poles or fire hydrants
- No mobile food vendor unit may be used to advertise any product which is not authorized to be sold from that unit
- Each mobile food vendor unit shall be limited to one sandwich board sign that meets the provisions of Section 20.05.086 of the Bloomington Municipal Code regardless of the zoning district in which it locates, provided a sign permit is obtained from the City's Planning and Transportation Department
- No mobile food vendor unit may make use of any public or private electrical outlet while in operation
- Each mobile food vendor unit shall protect against littering and shall have both an adequate trash receptacle and a separate receptacle for recyclable materials:
 - The trash and recyclable receptacles shall be emptied sufficiently often to allow disposal of litter and waste by the public at any time;
 - The trash and recyclable receptacles on the mobile food vendor unit shall not be emptied into trash or recyclable receptacles owned by the City of Bloomington;
 - Liquid from the mobile food vendor unit shall not be discharged on or in a City sewer or drain or elsewhere on City property, nor on private property without the express written consent of the owner thereof;

- Before leaving any location each mobile food vendor unit shall first pick up, remove and dispose of all trash, refuse and/or recyclable materials, including products spilled on the ground within twenty feet of the mobile food vendor unit.
- No mobile food vendor unit shall expose any pedestrian to any undue safety or health hazards nor shall it be maintained so as to create a public nuisance
- Each mobile food vendor unit shall be maintained free and clear of dirt, and finishes shall not be chipped, faded or unduly marred
- Foods or beverages which present a substantial likelihood that liquid matter or particles will drop to the street or sidewalk during the process of carrying or consuming the food or beverage shall be sold in proper containers so as to avoid falling to the street or sidewalk
- Mobile food vendor units which utilize a grill or device that may result in a spark, flame or fire shall adhere to the following additional standards:
 - Be placed approximately 20 feet from a building or structure;
 - Provide a barrier between the grill or device and the general public;
 - The spark, flame or fire shall not exceed 12 inches in height;
 - A fire extinguisher shall be within reaching distance of the mobile food vendor unit operator at all times;
- Mobile food vendor unit operators shall be required to obey the commands of law enforcement officers or fire officials with respect to activity carried out inside of the City's jurisdictional limits, including, where possible, the removal of the mobile food vendor unit and cessation of such sales
- No mobile food vendor unit shall ever be left unattended
- Mobile food vendor units shall not be stored, parked or left overnight on any City property
- All mobile food vendor units which are food service establishments as defined by Title 10.17 of the Bloomington Municipal Code shall install an approved grease interceptor or grease trap. Foods, oils and greases shall never be discharged into the City's sewer or storm drains
- All mobile food vendor unit operators are required to collect and pay all applicable and appropriate sales taxes
- No mobile food vendor shall provide customer seating unless approval has been provided by the City's Board of Public Works and the City's Planning and Transportation Department
- All mobile food vendors shall comply with the lighting standards found in Chapter 20.05 of the Bloomington Municipal Code
- All mobile food vendors shall comply with the vision clearance standards found in Chapter 20.05 of the Bloomington Municipal Code
- No mobile food vendor shall have a drive-thru
- The decibels of any generator(s) associated with a mobile food vendor unit shall not exceed "70dBA".
 - Such noise measurement shall be made at a height of at least four (4) feet above the ground and at a point approximately twenty-five (25) feet away from where the

noise is being emitted on a sound level meter operated on the "A" weighting network (scale).

- No person other than the operators shall be within twenty-five (25) feet of the sound level meter during the sample period.
- Sound measurements shall be conducted at that time of day or night when the relevant noise source is emitting sound.
- The sound level measurement shall be determined as follows:
 - Calibrate the sound level meter within one (1) hour before use.
 - Set the sound level meter on the "A" weighted network at slow response.
 - Set the omnidirectional microphone in an approximately seventy degree position in a location which complies with subsections (1) and (2) herein. The operator of the sound level meter shall face the noise source and record the meter's instantaneous response.
 - Recalibrate the sound level meter after use.
- It shall be unlawful for any person to interfere, through the use of sound or otherwise, with the taking of sound level measurement.

I, the undersigned, understand that if I conduct business in violation of any the above described standards of conduct that I subject myself to fines and possible revocation of my Mobile Vendor Unit License, as so described in Chapter 4.28 of the Bloomington Municipal Code.

Vendor:

Name: WARREN STOHLEN

Signature: Warren Stohlen

Date: AUG 14, 2024

<u>Festival General Contact Information</u>			
<u>Event</u>	<u>Dates</u>	<u>Contact Person</u>	<u>Phone Number</u>
Bloomington Farmers' Market	Every Saturday, April – November	Clarence Boone, Market Coordinator	(812) 349-3700
Strawberry Festival	Mid-May	Christina Hurlow, Boys & Girls Club	812-287-8771
Taste of Bloomington	Mid-June	Talisha Coppock, Co-Director	(812) 336-3681
Arts Fair on the Square	Mid-August	Lee Burckes, Event Manager	(812) 334-1188
4th of July Parade	July 4th	Talisha Coppock,	(812) 349-3700
4th Street Festival	Early September	4th Street Committee	(812) 335-3814
Lotus World Music and Arts Festival	Late September	Lotus Office	(812) 336-3959
Bloomington Holiday Market	Final Farmers' Market	Clarence Boone, Market Coordinator	(812) 349-3700
Canopy of Lights	Friday after Thanksgiving	Talisha Coppock	(812) 336-3681
<u>Itinerant Merchant Contact Information</u>			
<u>Permit Issuer</u>	<u>Location</u>	<u>Contact Person</u>	<u>Phone Number</u>
Monroe County Health Department (Food Handler Permit)	119 W. 7th St. Bloomington, IN	Sylvia Garrison, Administrator	(812) 349-2543
Bloomington Board of Public Works (Conducting Business in Public Right-of-Way)	401 N. Morton St. Suite 150 Bloomington, IN	Jane Kupersmith, Economic & Sustainable Development	(812) 349-3419
Bloomington Parks and Recreation Department (Conducting Business on City of Bloomington Parks Property)	401 N. Morton St. Suite 250 Bloomington, IN	Kim Clapp, Office Manager	(812) 349-3700
Bloomington Fire Department (Conducting Business that will produce any type of spark/fire hazard)	300 E. 4th St. Bloomington, IN	Fire Administration	(812) 332-9763



Mobile Food Service Establishment License

Monroe County Health Department

This is to certify that:

Kona Ice Unit #1
StohlerProperty Management LLC
190 N. Sycamore
Martinsville, IN 46151

Having complied with the rules and regulations of the Monroe County Health Department as authorized by the Indiana Administrative Code and the Board of Commissioners of Monroe County, Indiana, is hereby authorized to operate a Food Service Establishment at the above location for the calendar year.



Issued:

3/8/2024

2024

By

A handwritten signature in black ink, appearing to read 'D. Stohler', is written over a horizontal line.

Monroe County Health Officer

NON-NEGOTIABLE AND NOT TRANSFERABLE

PERMIT EXPIRES FEBRUARY 28, 2025



KONA ICE
Kräfted
GOURMET SHAVED ICE

KONA ICE
Kräfted
GOURMET SHAVED ICE

KONA-ICE.COM

RESOLUTION 2024-061
CITY OF BLOOMINGTON
BOARD OF PUBLIC WORKS
Mobile Vendor in Public Right of Way
Kona Ice of Bloomington - Truck 1

WHEREAS, the Board of Public Works is empowered by Indiana Code § 36-9-6-2 to supervise the streets, alleys, sewers, public grounds, and other property of the City of Bloomington (“City”);

WHEREAS, Kona Ice of Bloomington - Truck 1 (“Vendor”), is seeking a Mobile Vendor License under Bloomington Municipal Code 4.28;

WHEREAS, the issuance of a Mobile Vendor License under Bloomington Municipal Code 4.28 requires Vendor to submit documentation to the City—set forth at Bloomington Municipal Code 4.28.050—including an independent safety inspection, an open burn permit issued by the City of Bloomington Fire Department, and all applicable permits required by the Monroe County Health Department;

WHEREAS, Vendor has agreed to the Standards of Conduct set forth in Bloomington Municipal Code 4.28.160 and signed the Release, Hold-Harmless, and Indemnification Agreement as required by Bloomington Municipal Code 4.28.090;

WHEREAS, Vendor desires to be able to use “City property” as defined in Bloomington Municipal Code 4.28.010, which includes public on-street parking, on a temporary and transient basis for the purpose of selling food via a mobile kitchen, food truck or trailer; and

WHEREAS, under the Bloomington Municipal Code, approval to use public on-street parking and sidewalks is provided by the Board of Public Works via resolution;

NOW, THEREFORE, BE IT RESOLVED BY THE BOARD OF PUBLIC WORKS THAT:

1. Vendor has permission to use on-street public parking and sidewalks, on a temporary and transient basis, for the purposes of selling food via a mobile kitchen, food truck or trailer for 1 year beginning 9/12/2024, and ending on 9/12/2025.

2. For the avoidance of doubt, this Resolution is not the Business License referenced by Chapter 4.28 of the Bloomington Municipal Code. Thus, Vendor must ensure that all necessary documentation has been submitted to the City of Bloomington Controller and that the Business License has been issued by the City of Bloomington Controller before utilizing the permission to use on-street public parking and sidewalks granted in the paragraph above. Operating a mobile vendor without a business license is a violation of Bloomington Municipal Code 4.28.180(a)(1), and would subject Vendor to a fine of \$2,500 for the first offense.

3. For the avoidance of doubt, the following conditions—which in some instances may mirror those that exist under Title 4.28 of the Bloomington Municipal Code—attach to this approval:

- a. Vendor agrees to maintain a clear five-foot path for pedestrians on the sidewalk at all times.
- b. Vendor will have obtained a valid Mobile Vendor license issued by the City of Bloomington Controller prior to operation on City property, and will maintain a valid Mobile Vendor license throughout the term of Vendor’s operation on City property.
- c. Vendor may locate his business in a public parking space within a reasonable time, no more than one hour, before the vendor begins selling food to persons. Vendor must still comply with all other restrictions regarding its location in a public parking space.

- d. Vendor shall remove his business from a public parking space within a reasonable time, no more than one hour, following the time the vendor has stopped selling food to persons. Vendor must still comply with all other restrictions regarding its location in a public parking space.
- e. Vendor will comply with all other laws, ordinances, rules and regulations in effect at the time it conducts their business, including, but not limited to: (1) Bloomington Municipal Code 4.28 (Mobile Vendors), and (2) all City parking regulations, restrictions, and ordinances.
- f. Vendor is prohibited from operating within a one block radius of a Special Event, unless prior approval has been granted by either the operator of the Special Event or the City’s Board of Public Works. The Board of Public Works is not required to provide specific notice to Vendor when it recognizes a Special Event. The following are Special Events that have been recognized by the Board of Public Works:
 - 1) City of Bloomington Farmers’ Market;
 - 2) City of Bloomington Holiday Market;
 - 3) The Taste of Bloomington;
 - 4) Lotus World Music and Arts Festival;
 - 5) The Fourth Street Festival;
 - 6) Arts Fair on the Square;
 - 7) Strawberry Festival;
 - 8) Canopy of Lights;
 - 9) Fourth of July Parade; and
 - 10) Any other special events approved by the City Controller.

ADOPTED THIS THE 10th DAY OF SEPTEMBER, 2024.

BOARD OF PUBLIC WORKS:

Kyla Cox Deckard, President

Elizabeth Karon, Vice President

James Roach, Secretary

ALL TERMS AND CONDITIONS CONTAINED IN THIS RESOLUTION 2024-061 ARE ACCEPTABLE AND AGREED TO BY VENDOR:

Warren Stohler

Date: _____

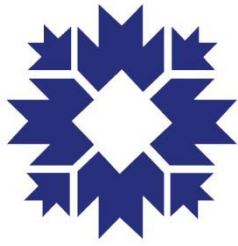

**CITY OF
BLOOMINGTON**
ECONOMIC AND SUSTAINABLE DEVELOPMENT

Project/Event: Mobile Vendor in Right of Way
PW Resolution No: 2024-062
Petitioner/Representative: Warren Stohler, Owner of Kona Ice of
Bloomington - Truck 2
Staff Representative: Susan Coates
Meeting Date: 09/10/2024

Kona Ice of Bloomington - Truck 2, by its owner, Warren Stohler, has applied for a Mobile Vendor License to operate a food truck/trailer. An applicant wanting to operate in the right of way must obtain permission from the Board of Public Works before a license may be issued. The Department of Economic & Sustainable Development has reviewed the application and will confirm that all rules and regulations have been met prior to issuing a license.

The business will be selling food via a mobile kitchen, food truck or trailer.

This application is for 1 year.

Staff is supportive of the request.

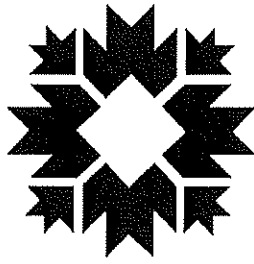

CITY OF BLOOMINGTON

ECONOMIC AND SUSTAINABLE DEVELOPMENT

Business License Cover Sheet

Business Name	Kona Ice of Bloomington - Truck 2
License Type	Mobile Vendor License
Contact	Warren Stohler
Phone	317-363-7810
Email	wstohler@kona-ice.com
BPW Resolution No (if applicable)	2024-062
Issue Date of License	9/12/2024
Expiration Date of License	9/12/2025
Scanned?	<input checked="" type="checkbox"/>
Renewal Date for License	9/12/2025
Department Head	Jane Kupersmith
Record Destruction Date	9/12/2028
ESD Tracking No	N/A
Document Physical Filing Location	2-drawer file cabinet at ESD Admin's desk
Document Digital Filing Location	I:\common\Economic Development\BUSINESS\Business Licensing\Licenses\Mobile Vendor License\Businesses

Truck 2.



CITY OF BLOOMINGTON

MOBILE VENDOR LICENSE APPLICATION

City of Bloomington
Department of Economic and Sustainable Development
401 N. Morton St. Suite 150
Bloomington, Indiana 47404
812-349-3418

1. License Length and Fee Application

Length of License: 1 Year - \$350

pd 9/3/17
CK #1063

2. Applicant Information

Name:	WARREN STOLLER		
Title/Position:	OWNER / OPERATOR		
Date of Birth:	10/02/1953		
Address:	4610 Hackm Creek Rd		
City, State, Zip:	MARTINSVILLE, IN 46151		
E-Mail Address:	WSTOLLER@KONA-ICE.COM		
Phone Number:	317-363-7810	Mobile Phone:	765-610-5934

3. Indiana Contact Information (For non-residents only)

If applicant is not a resident of Indiana, they must designate a resident to serve as a contact.			
Name:	NA		
Address:	NA		
City, State, Zip:	NA		
E-Mail Address:	NA		
Phone Number:		Mobile Phone:	

4. Company Information

Name of Employer:	KONA ICE OF BLOOMINGTON		
Address of Employer:	4610 Hackel Creek Rd		
City, State, Zip:	MARTINSVILLE IN 46151		
Employment Start Date:	June 2014	End Date (If known):	TO DATE
Phone Number:	317-363-7810		
Website / Email:	KONA-ICE.COM		
Company is a:	<input checked="" type="checkbox"/> Limited Liability Corporation (LLC)	<input type="checkbox"/> Corporation	<input type="checkbox"/> Partnership
		<input type="checkbox"/> Sole Proprietor	<input type="checkbox"/> Other:

5. Company Officer Information

Provide the names and addresses of all principal officers, partners, trustees, owners or other persons with controlling interests in the company.

Name	Address
WARREN STOHLER	4610 Hackel Creek Rd 46151
DEBBIE STOHLER	4610 Hackel Creek Rd 46151

6. Company Incorporation Information (For Corporations and LLCs Only)

Date of incorporation or organization:	June 2014
State of incorporation or organization:	INDIANA
(If Not Indiana) Date qualified to transact business in state of Indiana:	

7. Description of product or service to be sold and any equipment to be used

Planned hours of operation:	<i>Sun up to Sun down ANY SCHEDULED EVENT</i>
Place or places where you will conduct business (If private property, attach written permission from property owner):	
Scaled site plan showing the location of the proposed mobile food vendor unit and the properties' drives, parking access aisles, fire lanes, sidewalks and accessible routes.	Please Attach
Have you had a similar license, either from the City of Bloomington, or a different municipality, revoked?	Yes <input type="checkbox"/> No <input checked="" type="checkbox"/>
(If Yes) Provide details	

Res.
2024-062

8. You are required to secure, attach, and submit the following:

<input checked="" type="checkbox"/>	A copy of the Indiana registration for the vehicle
<input checked="" type="checkbox"/>	Copy of a valid driver's license
<input checked="" type="checkbox"/>	Copy of an Indiana Driver's Record and/or equivalent of whatever State has issued the applicant his/her driver's license
<input checked="" type="checkbox"/>	Proof of an independent safety inspection of all vehicles to be used in the business (form included with app)
<input checked="" type="checkbox"/>	Proof of insurance in accordance with the limits described in Section 4.28.090 of the Bloomington Municipal Code: <ul style="list-style-type: none"> • Personal Injury: \$100,000.00 per occurrence and \$300,000 in the aggregate • Property Damage: \$25,000.00 per occurrence and \$50,000.00 in the aggregate
<input checked="" type="checkbox"/>	Release of liability wherein the Applicant agrees to indemnify and hold harmless the City of Bloomington for losses or expenses arising out of the operation of his/her business (included with application)
<input checked="" type="checkbox"/>	A copy of the business's registration with the Indiana Secretary of State.
<input checked="" type="checkbox"/>	A copy of the Employer ID number
<input checked="" type="checkbox"/>	A signed copy of the Prohibited Location Agreement (included with application)
<input checked="" type="checkbox"/>	A signed copy of the Standards of Conduct Agreement (included with application)
<input type="checkbox"/>	Fire inspection (if required)
<input checked="" type="checkbox"/>	Picture of truck or trailer
<input checked="" type="checkbox"/>	Copy of all applicable permits required by the Monroe County Health Department, including but not limited to a Food Service Establishment License or a Certified Food Handler License.

For City Of Bloomington Use Only

Received in ESD	Received By:	Date Approved:	Approved By:
SEP 03 2024	<i>Boats</i>	9/4/24	<i>[Signature]</i>



State Form 48099 (R57-17)
Approved by State Board of
Accounts 2017

INDIANA CERTIFICATE OF VEHICLE REGISTRATION

CLASS 13	AGE 7	ISSUE DATE 01/30/24	PUR DATE 05/10/17	COUNTY 55 - MORGAN	TP R	PL YR 24	PLATE YIZ311	PLTP SP	WEIGHT 11	PR YR 23	LS N	TYPE SP	PRIOR YR PL YIZ311
EXPIRATION DATE 01/31/25	MUNICIPALITY NONE OF THE ABOVE			VEHICLE YEAR 17	MAKE CHE	MODEL EXP	VEHICLE IDENTIFICATION NUMBER 1GB0GRFF2H1208127		TYPE VA	COLOR BLU/			
CURRENT YEAR TAX	EX TAX 65.00	EX CREDIT 0.00	DAV CREDIT 0.00	NET EX TAX 65.00	CO. WHEEL/SUR 25.00	MUN. WHEEL/SUR 0.00	STATE REG FEE 45.35	ADMIN FEE 0.00	TOTAL 135.35				
PRIOR YEAR TAX	EX TAX 0.00	EX CREDIT 0.00	DAV CREDIT 0.00	NET EX TAX 0.00	CO. WHEEL/SUR 0.00	MUN. WHEEL/SUR 0.00	STATE REG FEE 0.00	ADMIN FEE 0.00	TOTAL 0.00				
REGISTRATION LICENSE TYPE IN GOD WE TRUST NEW FORMAT HIGH DIGIT TRUCK 11,000													



Legal Address
4610 HACKER CREEK RD
MARTINSVILLE IN 46151-9433

STOHLER PROPERTY MANAGEMENT LL



**4610 HACKER CREEK RD
MARTINSVILLE IN 46151-9433**

0101



144:35:84

2



REGISTERED RETAIL MERCHANT CERTIFICATE

INDIANA DEPARTMENT OF REVENUE
100 N SENATE AVE
INDIANAPOLIS IN 46204-2253
(317) 232-2240

KONA ICE OF BLOOMINGTON INCORPORATED
4610 HACKER CREEK RD
MARTINSVILLE IN 46151-9433

FEIN 81-2690958
LOC ID 0158439155-001
ISSUED **December 02, 2021**
EXPIRES **December 31, 2023**

IS AUTHORIZED TO COLLECT INDIANA RETAIL SALES TAX AT THE
ADDRESS ABOVE IF DIFFERENT FROM BELOW.

THIS LICENSE:
IS NOT TRANSFERABLE TO ANY OTHER PERSON.
IS NOT SUBJECT TO REBATE.
IS VOID IF ALTERED.



KONA ICE OF BLOOMINGTON INCORPORATED
4610 HACKER CREEK RD
MARTINSVILLE IN 46151-9433

Robert J. ...

COMMISSIONER

MUST BE DISPLAYED BY MERCHANT IN THE LOCATION SHOWN

Background Verification Report

REQUESTED: 8/14/2024

PRINTED: 8/26/2024 12:01:25 PM

COMPLETED: 8/14/2024

APPLICANT INFORMATION

PROVIDED TO: Kona Ice of Bloomington

REQUESTED BY: Warren Stohler

ATTENTION: Kona Ice of Bloomington

PROVIDED BY: AUDI LLC

SUBJECT: STOHLER, WARREN E

SS #: XXX-XX-6423

ADDRESS: 4610 HACKER CREEK RD
MARTINSVILLE, IN 46151

DOB: 10/02/1953

RESULTS DETAILS

DRIVING HISTORY

Driver's License #: 8914850785

State Issued: IN

Reported Driver's License #: 8914850785

INDIANA DRIVER RECORD REPORT

REPORT SEARCH DATE -> 08/14/2024

LICENSE NAME/ADDRESS

DRIVER DESCRIPTION

STOHLER, WARREN EDWARD
4610 HACKER CREEK RD
MARTINSVILLE, IN 46151-9433

DOB/SS# | GENDER/RACE | HT/WT | EYES/H
===== | ===== | ===== | ===== | =====
10/02/53 | M | 511 | BLUE |
| | 195 | GRAY |

LICENSE NUMBER	ORIG. ISSUED	ISSUED	EXPIRES	CLASS	STATUS
8914850785		11/01/2019	10/02/2026	OPERATOR	VALID (DUPL)

POINTS: 0

LIC TYP: PERSONAL

STATUS: VALID (DUPLICATE LICENSE)

RESTRICTIONS: CORRECTIVE LENSES

ENDORSEMENTS: FOR HIRE - NON-CMV ONLY

*** MISCELLANEOUS AND STATE SPECIFIC INFORMATION ***

** REINSTATEMENT FEE: \$0.00

** NO INSURANCE FEE: \$0.00

- ** OR LEGISLATIVE ACTION OF THE ISSUING JURISDICTION RELATED TO COVID-19.
- ** PLEASE CONSULT WITH THE JURISDICTION FOR FURTHER DETAILS.
- ** MAILING 4610 HACKER CREEK RD MARTINSVILLE IN 46151-9433
- ** MAILING 4610 HACKER CREEK RD MARTINSVILLE IN 46151-9433
- ** MAILING 6280 S 625 W PENDLETON IN 46064-8972
- ** MAILING 6280 S 625 W PENDLETON IN 46064-8972
- ** MAILING 6280 S 625 W PENDLETON IN 46064-8972
- ** MAILING 15 S CREEDMOOR WAY ANDERSON IN 46011-9019
- ** MAILING 15 S CREEDMOOR WAY ANDERSON IN 46011-9019
- ** MAILING 1777 RACCOON WAY PENDLETON IN 46064-8605

NO REPORTABLE INCIDENTS FOUND

*** DRIVING RECORD HISTORY ***

Type	Viol/Susp	Conv/Reins Post/Expir	Description	Pts
OTHE	10/03/2019	10/02/2026	PERSONAL Sub Type.....: HISTORICAL LICENSE EN.....: FOR HIRE - NON-CMV ONLY RS.....: CORRECTIVE LENSES Class.....: OPERATOR Record Status.....: VALID (RENEW LICENSE)	
OTHE	08/14/2013	10/02/2019	PERSONAL Sub Type.....: HISTORICAL LICENSE RS.....: CORRECTIVE LENSES Class.....: CHAUFFEUR Record Status.....: EXPIRED (RENEW LICENSE)	
OTHE	10/03/2012	10/02/2016	PERSONAL Sub Type.....: HISTORICAL LICENSE RS.....: CORRECTIVE LENSES Class.....: OPERATOR (4 YEAR) NONPROB Record Status.....: EXPIRED (RENEW CDL LICENSE)	
OTHE	11/27/2010	10/02/2012	COMMERCIAL Sub Type.....: HISTORICAL LICENSE EN.....: PASSENGER TRANSPORT, DOUBLE/TRI RS.....: CORRECTIVE LENSES Class.....: B - VEH GCWR=>26,001 LBS W/TOWE Record Status.....: PENDING (AMEND CDL LICENSE)	
OTHE	10/01/2008	10/02/2012	COMMERCIAL Sub Type.....: HISTORICAL LICENSE EN.....: PASSENGER TRANSPORT, DOUBLE/TRI RS.....: CORRECTIVE LENSES Class.....: B - VEH GCWR=>26,001 LBS W/TOWE Record Status.....: EXPIRED (RENEW CDL LICENSE)	

Sub Type.....: HISTORICAL LICENSE
EN.....: PASSENGER TRANSPORT, DOUBLE/TRI
Class.....: B - VEH GCWR=>26,001 LBS W/TOWE
Record Status.....: EXPIRED (AMEND CDL LICENSE)

OTHE 03/02/2004 10/02/2008 COMMERCIAL

Sub Type.....: HISTORICAL LICENSE
EN.....: PASSENGER TRANSPORT, DOUBLE/TRI
RS.....: CORRECTIVE LENSES
Class.....: B - VEH GCWR=>26,001 LBS W/TOWE
Record Status.....: EXPIRED (RENEW LICENSE)

PERM 02/18/2004 08/31/2004 COMMERCIAL PERMIT

Permit Class.....: A - PERMIT FOR COMB VEH GCWR=>2
Permit Status.....: EXPIRED (AMEND CDL LICENSE)
Permit Restrictions.: CORRECTIVE LENSES
Permit Endorsements.: PASSENGER TRANSPORT, DOUBLE/TRI

OTHE 02/16/2004 10/02/2004 PERSONAL

Sub Type.....: HISTORICAL LICENSE
Class.....: OPERATOR
Record Status.....: EXPIRED (DUPLICATE LICENSE)

PERM 02/14/2004 08/31/2004 COMMERCIAL PERMIT

Permit Class.....: B - PERMIT FOR VEH GCWR=>26,001
Permit Status.....: EXPIRED (RENEW CDL PERMIT)
Permit Restrictions.: CORRECTIVE LENSES
Permit Endorsements.: PASSENGER TRANSPORT

OTHE 10/12/2000 10/02/2004 PERSONAL

Sub Type.....: HISTORICAL LICENSE
Class.....: OPERATOR
Record Status.....: EXPIRED (RENEW LICENSE)

OTHE 12/02/1996 10/31/2000 PERSONAL

Sub Type.....: HISTORICAL LICENSE
RS.....: CORRECTIVE LENSES
Class.....: OPERATOR
Record Status.....: EXPIRED (RENEW LICENSE)

*** END OF RECORD ***

08/14/24 07:07:04 AM

DISCLAIMER

Users should consult State and Federal laws before using this information in making decisions on hiring or firing of employees. By requesting any search, you certify that you assume full responsibility for compliance with the legal restrictions, terms of use, and applicable laws. You also agree to use all information provided to you that does not violate the Gramm-Leach-Bliley Act (GLBA), Fair Credit Reporting Act, 15 U.S.C. sec. 1681 et seq., (FCRA), Federal Trade Commission interpretations of the Fair

Permissible Use / Summary of Your Rights Under the Fair Credit Report

Permissible Use

Users should consult State and Federal laws before using this information in making decisions on hiring or firing of employees. By requesting any search, you certify that you assume full responsibility for compliance with the legal restrictions, terms of use, and applicable laws. You also agree to use all information provided to you that does not violate the Gramm-Leach-Bliley Act (GLBA), Fair Credit Reporting Act, 15 U.S.C. sec. 1681 et seq., (FCRA), Federal Trade Commission interpretations of the Fair Credit Reporting Act, and similar state statutes.

Para información en español, visite www.consumerfinance.gov/learnmore o escriba a la Consumer Financial Protection Bureau, 1700 G Street NW, Washington, DC 20552.

A Summary of Your Rights Under the Fair Credit Reporting Act

The federal Fair Credit Reporting Act (FCRA) promotes the accuracy, fairness, and privacy of information in the files of consumer reporting agencies. There are many types of consumer reporting agencies, including credit bureaus and specialty agencies (such as agencies that sell information about check writing histories, medical records, and rental history records).

Here is a summary of your major rights under FCRA. For more information, including information about additional rights, go to www.consumerfinance.gov/learnmore or write to: Consumer Financial Protection Bureau, 1700 G Street NW, Washington, DC 20552.

- You must be told if information in your file has been used against you. Anyone who uses a credit report or another type of consumer report to deny your application for credit, insurance, or employment - or to take another adverse action against you - must tell you, and must give you the name, address, and phone number of the agency that provided the information.
- You have the right to know what is in your file. You may request and obtain all the information about you in the files of a consumer reporting agency (your "file disclosure"). You will be required to provide proper identification, which may include your Social Security number. In many cases, the disclosure will be free. You are entitled to a free file disclosure if:
 - a person has taken adverse action against you because of information in your

credit report,

- o you are the victim of identity theft and place a fraud alert in your file;
- o your file contains inaccurate information as a result of fraud;
- o you are on public assistance;
- o you are unemployed but expect to apply for employment within 60 days.

In addition, all consumers are entitled to one free disclosure every 12 months upon

request from each nationwide credit bureau and from nationwide specialty consumer

reporting agencies. See www.consumerfinance.gov/learnmore for additional information.

- You have the right to ask for a credit score. Credit scores are numerical summaries of your credit-worthiness based on information from credit bureaus. You may request a

credit score from consumer reporting agencies that create scores or distribute scores used

in residential real property loans, but you will have to pay for it. In some mortgage

transactions, you will receive credit score information for free from the mortgage lender.

- You have the right to dispute incomplete or inaccurate information. If you identify information in your file that is incomplete or inaccurate, and report it to the consumer

reporting agency, the agency must investigate unless your dispute is frivolous. See

www.consumerfinance.gov/learnmore for an explanation of dispute procedures.

- Consumer reporting agencies must correct or delete inaccurate, incomplete, or unverifiable information. Inaccurate, incomplete, or unverifiable information must be

removed or corrected, usually within 30 days. However, a consumer reporting agency

may continue to report information it has verified as accurate.

- Consumer reporting agencies may not report outdated negative information. In most cases, a consumer reporting agency may not report negative information that is

more than seven years old, or bankruptcies that are more than 10 years old.

- Access to your file is limited. A consumer reporting agency may provide information

about you only to people with a valid need - usually to consider an application with a

creditor, insurer, employer, landlord, or other business. The FCRA specifies those with a

valid need for access.

- You must give your consent for reports to be provided to employers. A consumer reporting agency may not give out information about you to your employer, or a potential

employer, without your written consent given to the employer. Written consent generally

is not required in the trucking industry. For more information, go to

www.consumerfinance.gov/learnmore.

information in your credit report. Unsolicited prescreened offers for credit and

insurance must include a toll-free phone number you can call if you choose to remove

your name and address from the lists these offers are based on. You may opt out with the nationwide credit bureaus at 1-800-XXX-XXXX.

- The following FCRA right applies with respect to nationwide consumer reporting agencies:

CONSUMERS HAVE THE RIGHT TO OBTAIN A SECURITY FREEZE

You have a right to place a "security freeze" on your credit report, which will prohibit a consumer reporting agency from releasing information in your credit report without your express authorization. The security freeze is designed to prevent

credit, loans, and services from being approved in your name without your consent.

However, you should be aware that using a security freeze to take control over who gets

access to the personal and financial information in your credit report may delay, interfere

with, or prohibit the timely approval of any subsequent request or application you make

regarding a new loan, credit, mortgage, or any other account involving the extension of credit.

As an alternative to a security freeze, you have the right to place an initial or extended

fraud alert on your credit file at no cost. An initial fraud alert is a 1-year alert that is

placed on a consumer's credit file. Upon seeing a fraud alert display on a consumer's

credit file, a business is required to take steps to verify the consumer's identity before

extending new credit. If you are a victim of identity theft, you are entitled to an extended

fraud alert, which is a fraud alert lasting 7 years.

A security freeze does not apply to a person or entity, or its affiliates, or collection

agencies acting on behalf of the person or entity, with which you have an existing

account that requests information in your credit report for the purposes of reviewing or

collecting the account. Reviewing the account includes activities related to account

maintenance, monitoring, credit line increases, and account upgrades and enhancements.

- You may seek damages from violators. If a consumer reporting agency, or, in some

cases, a user of consumer reports or a furnisher of information to a consumer reporting

agency violates the FCRA, you may be able to sue in state or federal court.

- Identity theft victims and active duty military personnel have additional

States may enforce the FCRA, and many states have their own consumer reporting laws.

In some cases, you may have more rights under state law. For more information, contact

your state or local consumer protection agency or your state Attorney General. For

information about your federal rights, contact:

information about your federal rights, contact:

4

TYPE OF BUSINESS: CONTACT:

1.a. Banks, savings associations, and credit unions with total assets of over \$10 billion and their affiliates

b. Such affiliates that are not banks, savings associations, or credit unions also should list, in addition to the CFPB:

a. Consumer Financial Protection Bureau
1700 G Street NW

Washington, DC 20552

b. Federal Trade Commission

Consumer Response Center

600 Pennsylvania Avenue NW

Washington, DC 20580

(877) 382-4357

2. To the extent not included in item 1 above:

a. National banks, federal savings associations, and federal branches and federal agencies of foreign banks

b. State member banks, branches and agencies of foreign banks (other than federal branches, federal agencies, and Insured State Branches of Foreign Banks), commercial lending companies owned or controlled by foreign banks, and organizations operating under section 25 or 25A of the Federal Reserve Act.

c. Nonmember Insured Banks, Insured State Branches of Foreign Banks, and insured state savings associations

d. Federal Credit Unions

a. Office of the Comptroller of the Currency

Customer Assistance Group

P.O. Box 53570

Houston, TX 77052

b. Federal Reserve Consumer Help Center

P.O. Box 1200

Minneapolis, MN 55480

c. Division of Depositor and Consumer Protection

National Center for Consumer and Depositor Assistance

Federal Deposit Insurance Corporation

1100 Walnut Street, Box #11

Kansas City, MO 64106

d. National Credit Union Administration

Office of Consumer Financial Protection

1775 Duke Street

Alexandria, VA 22314

1200 New Jersey Avenue SE

Washington, DC 20590

4. Creditors Subject to the Surface Transportation Board Office of Public Assistance, Governmental Affairs, and Compliance

Surface Transportation Board

395 E Street SW

Washington, DC 20423

5. Creditors Subject to the Packers and Stockyards Act, 1921

Nearest Packers and Stockyards Division Regional Office

6. Small Business Investment Companies Associate Administrator, Office of Capital Access

United States Small Business Administration

409 Third Street SW, Suite 8200

Washington, DC 20416

7. Brokers and Dealers Securities and Exchange Commission

100 F Street NE

Washington, DC 20549

8. Institutions that are members of the Farm Credit System

Farm Credit Administration

1501 Farm Credit Drive

McLean, VA 22102-5090

9. Retailers, Finance Companies, and All Other Creditors Not Listed Above

Federal Trade Commission

Consumer Response Center

600 Pennsylvania Avenue NW

Washington, DC 20580

(877) 382-4357

CITY OF BLOOMINGTON

MOBILE VENDOR INSPECTION CHECK SHEET

COMPANY PERFORMING INSPECTION ARNOLD TIRE Co. Inc.
INSPECTOR'S NAME DON ARNOLD INSPECTOR'S PHONE # 765-342-8405
DATE OF INSPECTION 8-15-24
NAME OF VENDOR KONA ICE OF BLOOMINGTON
VEHICLE YEAR 2017 MAKE CHEVY MODEL 3500 EXPRESS VAN
VIN 1GB0GRFFZH1208127

	PASS	FAIL	COMMENTS
LIGHTS (Front & Rear)	✓		
FLASHERS	✓		
REFLECTORS	✓		
HORN	✓		
WINDSHIELD WIPERS	✓		
MIRRORS	✓		
SEATBELTS	✓		
BUMPER HEIGHT	✓		
ALL WINDOWS	✓		
MUFFLER	✓		
TIRES	✓		
BRAKES	✓		FRONT 70% REAR 80%
DOORS	✓		
GENERAL CONDITION OF VEHICLE	✓ GOOD		

Attach this completed Inspection Sheet with your permit or renewal application
and remit to:

City of Bloomington
Department of Economic and Sustainable Development
401 N. Morton St.
Bloomington, Indiana 47404
812-349-3419

Additional Comments by Inspector: _____

Inspector Signature Don Clark

Date: 8/15/24

**Attach this completed Inspection Sheet with your permit or renewal application
and remit to:
City of Bloomington
Department of Economic and Sustainable Development
401 N. Morton St.
Bloomington, Indiana 47404
812-349-3419**



CERTIFICATE OF LIABILITY INSURANCE

DATE (MM/DD/YYYY)

09/03/2024

THIS CERTIFICATE IS ISSUED AS A MATTER OF INFORMATION ONLY AND CONFERS NO RIGHTS UPON THE CERTIFICATE HOLDER. THIS CERTIFICATE DOES NOT AFFIRMATIVELY OR NEGATIVELY AMEND, EXTEND OR ALTER THE COVERAGE AFFORDED BY THE POLICIES BELOW. THIS CERTIFICATE OF INSURANCE DOES NOT CONSTITUTE A CONTRACT BETWEEN THE ISSUING INSURER(S), AUTHORIZED REPRESENTATIVE OR PRODUCER, AND THE CERTIFICATE HOLDER.

IMPORTANT: If the certificate holder is an ADDITIONAL INSURED, the policy(ies) must have ADDITIONAL INSURED provisions or be endorsed. If SUBROGATION IS WAIVED, subject to the terms and conditions of the policy, certain policies may require an endorsement. A statement on this certificate does not confer rights to the certificate holder in lieu of such endorsement(s).

PRODUCER Northern Kentucky Insurance 5915 Centennial Circle Florence KY 41042		CONTACT NAME: Amie Turner PHONE (A/C, No, Ext): (859)586-8580 E-MAIL ADDRESS: amie@cornerstoneinsllc.com FAX (A/C, No): (859)586-8616	
INSURED Kona Ice of Bloomington Inc. 4610 Hacker Creek Rd Martinsville IN 46151		INSURER(S) AFFORDING COVERAGE INSURER A: Great American Insurance Company NAIC # 16691 INSURER B: Great American Assurance Company 26344 INSURER C: Great American Spirit Insurance Company 33723 INSURER D: INSURER E: INSURER F:	

COVERAGES **CERTIFICATE NUMBER:** 2024-2025 **REVISION NUMBER:**

THIS IS TO CERTIFY THAT THE POLICIES OF INSURANCE LISTED BELOW HAVE BEEN ISSUED TO THE INSURED NAMED ABOVE FOR THE POLICY PERIOD INDICATED. NOTWITHSTANDING ANY REQUIREMENT, TERM OR CONDITION OF ANY CONTRACT OR OTHER DOCUMENT WITH RESPECT TO WHICH THIS CERTIFICATE MAY BE ISSUED OR MAY PERTAIN, THE INSURANCE AFFORDED BY THE POLICIES DESCRIBED HEREIN IS SUBJECT TO ALL THE TERMS, EXCLUSIONS AND CONDITIONS OF SUCH POLICIES. LIMITS SHOWN MAY HAVE BEEN REDUCED BY PAID CLAIMS.

INSR LTR	TYPE OF INSURANCE	ADDL INSD	SUBR WVD	POLICY NUMBER	POLICY EFF (MM/DD/YYYY)	POLICY EXP (MM/DD/YYYY)	LIMITS	
A	<input checked="" type="checkbox"/> COMMERCIAL GENERAL LIABILITY <input type="checkbox"/> CLAIMS-MADE <input checked="" type="checkbox"/> OCCUR GEN'L AGGREGATE LIMIT APPLIES PER: <input checked="" type="checkbox"/> POLICY <input type="checkbox"/> PROJECT <input type="checkbox"/> LOC OTHER:			BOP3805994	06/29/2024	06/29/2025	EACH OCCURRENCE	\$ 2,000,000
							DAMAGE TO RENTED PREMISES (Ea occurrence)	\$ 500,000
							MED EXP (Any one person)	\$ 10,000
							PERSONAL & ADV INJURY	\$ 2,000,000
							GENERAL AGGREGATE	\$ 4,000,000
							PRODUCTS - COMP/OP AGG	\$ 4,000,000
								\$
B	<input checked="" type="checkbox"/> AUTOMOBILE LIABILITY <input checked="" type="checkbox"/> ANY AUTO <input type="checkbox"/> OWNED AUTOS ONLY <input type="checkbox"/> SCHEDULED AUTOS <input type="checkbox"/> HIRED AUTOS ONLY <input type="checkbox"/> NON-OWNED AUTOS ONLY <input type="checkbox"/>			CAP3805995	06/29/2024	06/29/2025	COMBINED SINGLE LIMIT (Ea accident)	\$ 1,000,000
							BODILY INJURY (Per person)	\$
							BODILY INJURY (Per accident)	\$
							PROPERTY DAMAGE (Per accident)	\$
								\$
	<input type="checkbox"/> UMBRELLA LIAB <input type="checkbox"/> OCCUR <input type="checkbox"/> EXCESS LIAB <input type="checkbox"/> CLAIMS-MADE DED RETENTION \$						EACH OCCURRENCE	\$
							AGGREGATE	\$
								\$
C	<input type="checkbox"/> WORKERS COMPENSATION AND EMPLOYERS' LIABILITY ANY PROPRIETOR/PARTNER/EXECUTIVE OFFICER/MEMBER EXCLUDED? (Mandatory in NH) If yes, describe under DESCRIPTION OF OPERATIONS below		N/A	WC3805996	06/29/2024	06/29/2025	<input checked="" type="checkbox"/> PER STATUTE <input type="checkbox"/> OTHER	
							E.L. EACH ACCIDENT	\$ 1,000,000
							E.L. DISEASE - EA EMPLOYEE	\$ 1,000,000
							E.L. DISEASE - POLICY LIMIT	\$ 1,000,000

DESCRIPTION OF OPERATIONS / LOCATIONS / VEHICLES (ACORD 101, Additional Remarks Schedule, may be attached if more space is required)
 Certificate holder is listed as an additional insured with regards to the operations of the named insured.

CERTIFICATE HOLDER City of Bloomington 401 North Morton St. Bloomington IN 47404		CANCELLATION SHOULD ANY OF THE ABOVE DESCRIBED POLICIES BE CANCELLED BEFORE THE EXPIRATION DATE THEREOF, NOTICE WILL BE DELIVERED IN ACCORDANCE WITH THE POLICY PROVISIONS. AUTHORIZED REPRESENTATIVE 	
--	--	---	--

Kerry Thomson
Mayor
CITY OF BLOOMINGTON
401 N. Morton St Suite 130
P.O. Box 100
Bloomington, Indiana 47402

**DEPARTMENT OF ECONOMIC
& SUSTAINABLE DEVELOPMENT**
p. 812.349.3418
f. 812.349.3520

RELEASE, HOLD-HARMLESS AND INDEMNIFICATION AGREEMENT

The undersigned, in consideration for the issuance of a license by the City of Bloomington Controller, agrees to the following:

1. The undersigned, in exchange for the issuance of a license by the City of Bloomington Controller, agrees to release, hold harmless, and forever indemnify the City of Bloomington and any and all City employees, officers, and agents from any claim or claims which may arise out of any incident connected with or in any way related to his/her issuance of a license by the City of Bloomington or his/her operation of a business which was licensed by the City of Bloomington. This includes claims for personal injury, death, property damage, and/or any other type of harm or injury.
2. The undersigned shall, and hereby does, indemnify, defend, and hold harmless the City of Bloomington and any and all City employees, officers, and agents from and against any and all actions, costs, claims, suits, losses, expenses or damages, including but not limited to attorneys' fees and court costs, arising out of the undersigned's operation of a business which has been licensed by the City of Bloomington.
3. The undersigned understands this release binds him/herself, his/her spouse, and all heirs, executors, partners, co-owners and administrators of those individuals.

The undersigned acknowledges that he/she has read this release and understands all of its terms. The undersigned signs this release voluntarily and with full knowledge of its significance.

WARREN STOKER
Name, Printed

Warren Stoker
Signature

AUG 14, 2024
Date Release Signed

Kerry Thomson
Mayor
CITY OF BLOOMINGTON
 401 N. Morton St Suite 130
 P.O. Box 100
 Bloomington, Indiana 47402

DEPARTMENT OF ECONOMIC
 & SUSTAINABLE DEVELOPMENT
 p. 812.349.3418
 f. 812.349.3520

Prohibited Location Agreement

Bloomington Municipal Code Section 4.28.140 prohibits Mobile Vendor Units from operating in certain locations. This Agreement provides for all of the prohibited locations. Two maps are also attached to this Agreement. All signatories to this Agreement are required to review not only this Agreement, but also the attached maps prior to signing this Agreement.

As a licensed Mobile Vendor Unit, I understand and agree that I cannot and will not operate my mobile vendor unit in a manner that would violate any of the below-listed location restrictions:

- No mobile food vendor unit shall locate in any parking lot, parking space, or parking facility owned, leased or managed by the City of Bloomington unless approval has been given by the City's Board of Public Works.
- No mobile food vendor unit shall operate within fifty feet of any facade of a ground level establishment that also sells food or beverages, or operate within fifty feet of the perimeter of such an establishment's outdoor seating area, regardless of whether or not the mobile food vendor unit is currently conducting business. The distance restriction only applies from one hour before the opening time to an hour after the closing time posted by a ground level establishment on the facade of its building.
- No mobile food vendor unit shall locate in an alleyway.
- Mobile food vendor units shall be located a reasonable distance from all posted bus stops, crosswalks, driveways, alleyways, right-of-way lines of two or more intersecting streets and building entrances or walk-up windows.
- Mobile food vendor units shall only be located on private property if the private property owner has provided both the business operator and the City written permission for the mobile food vendor unit to locate on said property.
- No mobile food vendor unit shall locate within a one block radius of a Special Event unless prior approval has been granted by either the operator of the Special Event or the City's Board of Public Works.
- No mobile food vendor unit shall park on City property in violation of any City parking regulation, restriction, or ordinance. For example, if parking at one, or multiple, parking meters, the operator of the mobile food vendor unit shall feed all relevant parking meters with the required monetary amount.
- No mobile food vendor unit shall be located in a manner which would significantly impede or prevent the use of any City of Bloomington property, or which would endanger the safety or property of the public.
- No mobile food vendor unit shall be located within fifteen feet of any fire hydrant.

- No mobile food vendor shall locate within any zoning district except the following: Commercial General; Commercial Arterial; Commercial Downtown; Industrial General; Business Park; and Institutional.
- No mobile food vendor operating on private property shall displace required parking or landscaping nor block any drives, parking access aisles, fire lanes, sidewalks, or accessible routes required for the private parking by the City's zoning code.
- No mobile food vendor unit shall be located more than one foot away from the curb of the street on which it is parked.
- No mobile food vendor unit shall park near an intersection and in a manner that blocks the line-of-sight of drivers using adjacent roadways.

I, the undersigned, understand that if I locate my mobile vendor unit in any of the above-described prohibited locations or manner that I subject myself to fines and possible revocation of my Mobile Vendor Unit License, as so described in Chapter 4.28 of the Bloomington Municipal Code.

Vendor:

Name: WARREN STOLLER

Signature: Warren Stoller

Date: AUG 14, 2024

Kerry Thomson
Mayor
CITY OF BLOOMINGTON
401 N. Morton St Suite 130
P.O. Box 100
Bloomington, Indiana 47402

DEPARTMENT OF ECONOMIC
& SUSTAINABLE DEVELOPMENT

p. 812.349.3418

f. 812.349.3520

Standard of Conduct Agreement

Bloomington Municipal Code Section 4.28.160 provides Standards of Conduct for all Mobile Vendor Units. This Agreement provides a list of said Standards of Conduct. All signatories to this Agreement are required to review this Agreement prior to signing this Agreement.

As a licensed Mobile Vendor Unit, I understand and agree that I cannot and will not conduct business in a manner that would violate any of the Standards of Conduct noted below:

- Mobile food vendor unit operators shall conduct themselves at all times in an orderly and lawful manner, and shall not make, or cause to be made, any unreasonable noise of such volume as to be in violation of the City of Bloomington Noise Ordinance as stated in Title 14 of the Bloomington Municipal Code
- A device may not be used which would amplify sounds nor may attention be drawn to the mobile food vendor unit by an aural means or a light-producing device (examples of such devices may include, but are not meant to be limited to the following: bull horns and strobe lights
- No mobile food vendor unit may be permanently or temporarily affixed to any object, including but not limited to buildings, trees, telephone poles, streetlight poles, traffic signal poles or fire hydrants
- No mobile food vendor unit may be used to advertise any product which is not authorized to be sold from that unit
- Each mobile food vendor unit shall be limited to one sandwich board sign that meets the provisions of Section 20.05.086 of the Bloomington Municipal Code regardless of the zoning district in which it locates, provided a sign permit is obtained from the City's Planning and Transportation Department
- No mobile food vendor unit may make use of any public or private electrical outlet while in operation
- Each mobile food vendor unit shall protect against littering and shall have both an adequate trash receptacle and a separate receptacle for recyclable materials:
 - The trash and recyclable receptacles shall be emptied sufficiently often to allow disposal of litter and waste by the public at any time;
 - The trash and recyclable receptacles on the mobile food vendor unit shall not be emptied into trash or recyclable receptacles owned by the City of Bloomington;
 - Liquid from the mobile food vendor unit shall not be discharged on or in a City sewer or drain or elsewhere on City property, nor on private property without the express written consent of the owner thereof;

- Before leaving any location each mobile food vendor unit shall first pick up, remove and dispose of all trash, refuse and/or recyclable materials, including products spilled on the ground within twenty feet of the mobile food vendor unit.
- No mobile food vendor unit shall expose any pedestrian to any undue safety or health hazards nor shall it be maintained so as to create a public nuisance
- Each mobile food vendor unit shall be maintained free and clear of dirt, and finishes shall not be chipped, faded or unduly marred
- Foods or beverages which present a substantial likelihood that liquid matter or particles will drop to the street or sidewalk during the process of carrying or consuming the food or beverage shall be sold in proper containers so as to avoid falling to the street or sidewalk
- Mobile food vendor units which utilize a grill or device that may result in a spark, flame or fire shall adhere to the following additional standards:
 - Be placed approximately 20 feet from a building or structure;
 - Provide a barrier between the grill or device and the general public;
 - The spark, flame or fire shall not exceed 12 inches in height;
 - A fire extinguisher shall be within reaching distance of the mobile food vendor unit operator at all times;
- Mobile food vendor unit operators shall be required to obey the commands of law enforcement officers or fire officials with respect to activity carried out inside of the City's jurisdictional limits, including, where possible, the removal of the mobile food vendor unit and cessation of such sales
- No mobile food vendor unit shall ever be left unattended
- Mobile food vendor units shall not be stored, parked or left overnight on any City property
- All mobile food vendor units which are food service establishments as defined by Title 10.17 of the Bloomington Municipal Code shall install an approved grease interceptor or grease trap. Foods, oils and greases shall never be discharged into the City's sewer or storm drains
- All mobile food vendor unit operators are required to collect and pay all applicable and appropriate sales taxes
- No mobile food vendor shall provide customer seating unless approval has been provided by the City's Board of Public Works and the City's Planning and Transportation Department
- All mobile food vendors shall comply with the lighting standards found in Chapter 20.05 of the Bloomington Municipal Code
- All mobile food vendors shall comply with the vision clearance standards found in Chapter 20.05 of the Bloomington Municipal Code
- No mobile food vendor shall have a drive-thru
- The decibels of any generator(s) associated with a mobile food vendor unit shall not exceed "70dBA".
 - Such noise measurement shall be made at a height of at least four (4) feet above the ground and at a point approximately twenty-five (25) feet away from where the

noise is being emitted on a sound level meter operated on the "A" weighting network (scale).

- No person other than the operators shall be within twenty-five (25) feet of the sound level meter during the sample period.
- Sound measurements shall be conducted at that time of day or night when the relevant noise source is emitting sound.
- The sound level measurement shall be determined as follows:
 - Calibrate the sound level meter within one (1) hour before use.
 - Set the sound level meter on the "A" weighted network at slow response.
 - Set the omnidirectional microphone in an approximately seventy degree position in a location which complies with subsections (1) and (2) herein. The operator of the sound level meter shall face the noise source and record the meter's instantaneous response.
 - Recalibrate the sound level meter after use.
- It shall be unlawful for any person to interfere, through the use of sound or otherwise, with the taking of sound level measurement.

I, the undersigned, understand that if I conduct business in violation of any the above described standards of conduct that I subject myself to fines and possible revocation of my Mobile Vendor Unit License, as so described in Chapter 4.28 of the Bloomington Municipal Code.

Vendor:

Name: WARREN STÖHLER

Signature: Warren Stohler

Date: AUG 14, 2024

<u>Festival General Contact Information</u>			
<u>Event</u>	<u>Dates</u>	<u>Contact Person</u>	<u>Phone Number</u>
Bloomington Farmers' Market	Every Saturday, April – November	Clarence Boone, Market Coordinator	(812) 349-3700
Strawberry Festival	Mid-May	Christina Hurlow, Boys & Girls Club	812-287-8771
Taste of Bloomington	Mid-June	Talisha Coppock, Co-Director	(812) 336-3681
Arts Fair on the Square	Mid-August	Lee Burckes, Event Manager	(812) 334-1188
4th of July Parade	July 4th	Talisha Coppock,	(812) 349-3700
4th Street Festival	Early September	4th Street Committee	(812) 335-3814
Lotus World Music and Arts Festival	Late September	Lotus Office	(812) 336-3959
Bloomington Holiday Market	Final Farmers' Market	Clarence Boone, Market Coordinator	(812) 349-3700
Canopy of Lights	Friday after Thanksgiving	Talisha Coppock	(812) 336-3681
<u>Itinerant Merchant Contact Information</u>			
<u>Permit Issuer</u>	<u>Location</u>	<u>Contact Person</u>	<u>Phone Number</u>
Monroe County Health Department (Food Handler Permit)	119 W. 7th St. Bloomington, IN	Sylvia Garrison, Administrator	(812) 349-2543
Bloomington Board of Public Works (Conducting Business in Public Right-of-Way)	401 N. Morton St. Suite 150 Bloomington, IN	Jane Kupersmith, Economic & Sustainable Development	(812) 349-3419
Bloomington Parks and Recreation Department (Conducting Business on City of Bloomington Parks Property)	401 N. Morton St. Suite 250 Bloomington, IN	Kim Clapp, Office Manager	(812) 349-3700
Bloomington Fire Department (Conducting Business that will produce any type of spark/fire hazard)	300 E. 4th St. Bloomington, IN	Fire Administration	(812) 332-9763



WE ARE
**NUTRITIOUS
DELICIOUS**

LOOK MOM
NO HANDS!

**BEST JOB
EVER!**

FLAVOR
FLAVORS

ENJOY YOUR KONA IN A
**COLOR CHANGING
CUP!**

ENJOY YOUR KONA IN A
PATRIOTIC CUP
COLLECT ALL 4

KONA ICE

VISIT US & ORDER STICKERS
317.363.7810
WWW.KONA-ICE.COM

*Tropical
Shaved*
**KONA
ICE**

KONA-ICE.COM

Mobile Food Service Establishment License Monroe County Health Department

This is to certify that:

Kona Ice Mobile 2
StohlerProperty Management LLC
190 N Sycamore Street
Martinsville, IN 46151

Having complied with the rules and regulations of the Monroe County Health Department as authorized by the Indiana Administrative Code and the Board of Commissioners of Monroe County, Indiana, is hereby authorized to operate a Food Service Establishment at the above location for the calendar year.



Issued:
3/8/2024

By *[Signature]*
Monroe County Health Officer

2024

NON-NEGOTIABLE AND NOT TRANSFERABLE

PERMIT EXPIRES FEBRUARY 28, 2025

RESOLUTION 2024-062
CITY OF BLOOMINGTON
BOARD OF PUBLIC WORKS
Mobile Vendor in Public Right of Way
Kona Ice of Bloomington - Truck 2

WHEREAS, the Board of Public Works is empowered by Indiana Code § 36-9-6-2 to supervise the streets, alleys, sewers, public grounds, and other property of the City of Bloomington (“City”);

WHEREAS, Kona Ice of Bloomington - Truck 2 (“Vendor”), is seeking a Mobile Vendor License under Bloomington Municipal Code 4.28;

WHEREAS, the issuance of a Mobile Vendor License under Bloomington Municipal Code 4.28 requires Vendor to submit documentation to the City—set forth at Bloomington Municipal Code 4.28.050—including an independent safety inspection, an open burn permit issued by the City of Bloomington Fire Department, and all applicable permits required by the Monroe County Health Department;

WHEREAS, Vendor has agreed to the Standards of Conduct set forth in Bloomington Municipal Code 4.28.160 and signed the Release, Hold-Harmless, and Indemnification Agreement as required by Bloomington Municipal Code 4.28.090;

WHEREAS, Vendor desires to be able to use “City property” as defined in Bloomington Municipal Code 4.28.010, which includes public on-street parking, on a temporary and transient basis for the purpose of selling food via a mobile kitchen, food truck or trailer; and

WHEREAS, under the Bloomington Municipal Code, approval to use public on-street parking and sidewalks is provided by the Board of Public Works via resolution;

NOW, THEREFORE, BE IT RESOLVED BY THE BOARD OF PUBLIC WORKS THAT:

1. Vendor has permission to use on-street public parking and sidewalks, on a temporary and transient basis, for the purposes of selling food via a mobile kitchen, food truck or trailer for 1 year beginning 9/12/2024, and ending on 9/12/2025.

2. For the avoidance of doubt, this Resolution is not the Business License referenced by Chapter 4.28 of the Bloomington Municipal Code. Thus, Vendor must ensure that all necessary documentation has been submitted to the City of Bloomington Controller and that the Business License has been issued by the City of Bloomington Controller before utilizing the permission to use on-street public parking and sidewalks granted in the paragraph above. Operating a mobile vendor without a business license is a violation of Bloomington Municipal Code 4.28.180(a)(1), and would subject Vendor to a fine of \$2,500 for the first offense.

3. For the avoidance of doubt, the following conditions—which in some instances may mirror those that exist under Title 4.28 of the Bloomington Municipal Code—attach to this approval:

- a. Vendor agrees to maintain a clear five-foot path for pedestrians on the sidewalk at all times.
- b. Vendor will have obtained a valid Mobile Vendor license issued by the City of Bloomington Controller prior to operation on City property, and will maintain a valid Mobile Vendor license throughout the term of Vendor’s operation on City property.
- c. Vendor may locate his business in a public parking space within a reasonable time, no more than one hour, before the vendor begins selling food to persons. Vendor must still comply with all other restrictions regarding its location in a public parking space.

- d. Vendor shall remove his business from a public parking space within a reasonable time, no more than one hour, following the time the vendor has stopped selling food to persons. Vendor must still comply with all other restrictions regarding its location in a public parking space.
- e. Vendor will comply with all other laws, ordinances, rules and regulations in effect at the time it conducts their business, including, but not limited to: (1) Bloomington Municipal Code 4.28 (Mobile Vendors), and (2) all City parking regulations, restrictions, and ordinances.
- f. Vendor is prohibited from operating within a one block radius of a Special Event, unless prior approval has been granted by either the operator of the Special Event or the City’s Board of Public Works. The Board of Public Works is not required to provide specific notice to Vendor when it recognizes a Special Event. The following are Special Events that have been recognized by the Board of Public Works:
 - 1) City of Bloomington Farmers’ Market;
 - 2) City of Bloomington Holiday Market;
 - 3) The Taste of Bloomington;
 - 4) Lotus World Music and Arts Festival;
 - 5) The Fourth Street Festival;
 - 6) Arts Fair on the Square;
 - 7) Strawberry Festival;
 - 8) Canopy of Lights;
 - 9) Fourth of July Parade; and
 - 10) Any other special events approved by the City Controller.

ADOPTED THIS THE 10th DAY OF SEPTEMBER, 2024.

BOARD OF PUBLIC WORKS:

Kyla Cox Deckard, President

Elizabeth Karon, Vice President

James Roach, Secretary

ALL TERMS AND CONDITIONS CONTAINED IN THIS RESOLUTION 2024-062 ARE ACCEPTABLE AND AGREED TO BY VENDOR:

Warren Stohler

Date: _____

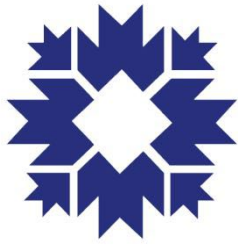

**CITY OF
BLOOMINGTON**
ECONOMIC AND SUSTAINABLE DEVELOPMENT

Project/Event: Mobile Vendor in Right of Way
PW Resolution No: 2024-063
Petitioner/Representative: Warren Stohler, Owner of Kona Ice of
Bloomington - Truck 3
Staff Representative: Susan Coates
Meeting Date: 09/10/2024

Kona Ice of Bloomington - Truck 3, by its owner, Warren Stohler, has applied for a Mobile Vendor License to operate a food truck/trailer. An applicant wanting to operate in the right of way must obtain permission from the Board of Public Works before a license may be issued. The Department of Economic & Sustainable Development has reviewed the application and will confirm that all rules and regulations have been met prior to issuing a license.

The business will be selling food via a mobile kitchen, food truck or trailer.

This application is for 1 year.

Staff is supportive of the request.

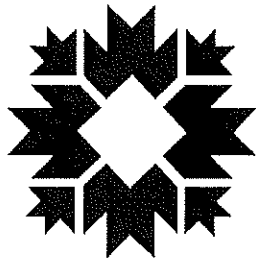

CITY OF BLOOMINGTON

ECONOMIC AND SUSTAINABLE DEVELOPMENT

Business License Cover Sheet

Business Name	Kona Ice of Bloomington - Truck 3
License Type	Mobile Vendor License
Contact	Warren Stohler
Phone	317-363-7810
Email	wstohler@kona-ice.com
BPW Resolution No (if applicable)	2024-063
Issue Date of License	9/12/2024
Expiration Date of License	9/12/2025
Scanned?	<input checked="" type="checkbox"/>
Renewal Date for License	9/12/2025
Department Head	Jane Kupersmith
Record Destruction Date	9/12/2028
ESD Tracking No	N/A
Document Physical Filing Location	2-drawer file cabinet at ESD Admin's desk
Document Digital Filing Location	I:\common\Economic Development\BUSINESS\Business Licensing\Licenses\Mobile Vendor License\Businesses



CITY OF BLOOMINGTON

MOBILE VENDOR LICENSE APPLICATION

City of Bloomington
Department of Economic and Sustainable Development
401 N. Morton St. Suite 150
Bloomington, Indiana 47404
812-349-3418

1. License Length and Fee Application

Length of License: 1 Year - \$350

*pd 9/4/24
ck# 1063*

2. Applicant Information

Name:	WARREN STOTLER		
Title/Position:	OWNER / OPERATOR		
Date of Birth:	10/02/1953		
Address:	4610 Hackm Creek Rd		
City, State, Zip:	MARTINSVILLE, IN 46151		
E-Mail Address:	WSTOTLER@KONA-ICE.COM		
Phone Number:	317-363-7810	Mobile Phone:	765-610-5934

3. Indiana Contact Information (For non-residents only)

If applicant is not a resident of Indiana, they must designate a resident to serve as a contact.			
Name:	NA		
Address:	NA		
City, State, Zip:			
E-Mail Address:			
Phone Number:		Mobile Phone:	

4. Company Information

Name of Employer:	KONA ICE OF BLOOMINGTON			
Address of Employer:	4610 Hackel Creek Rd			
City, State, Zip:	MARTINSVILLE IN 46151			
Employment Start Date:	June 2016	End Date (If known):	TO DATE	
Phone Number:	317-363-7810			
Website / Email:	KONA-ICE.COM			
Company is a:	<input checked="" type="checkbox"/> Limited Liability Corporation (LLC)	<input type="checkbox"/> Corporation	<input type="checkbox"/> Partnership	<input type="checkbox"/> Sole Proprietor

5. Company Officer Information

Provide the names and addresses of all principal officers, partners, trustees, owners or other persons with controlling interests in the company.

Name	Address
WARREN STOHLER	4610 Hackel Creek Rd 46151
DEBBIE STOHLER	4610 Hackel Creek Rd 46151

6. Company Incorporation Information (For Corporations and LLCs Only)

Date of incorporation or organization:	June 2016
State of incorporation or organization:	INDIANA
(If Not Indiana) Date qualified to transact business in state of Indiana:	

7. Description of product or service to be sold and any equipment to be used

Planned hours of operation:	<i>Sun up to Sun down ANY SCHEDULED EVENT</i>
Place or places where you will conduct business (If private property, attach written permission from property owner):	
Scaled site plan showing the location of the proposed mobile food vendor unit and the properties' drives, parking access aisles, fire lanes, sidewalks and accessible routes.	Please Attach
Have you had a similar license, either from the City of Bloomington, or a different municipality, revoked?	Yes <input type="checkbox"/> No <input checked="" type="checkbox"/>
(If Yes) Provide details	

Reg
2024-043

8. You are required to secure, attach, and submit the following:

<input checked="" type="checkbox"/>	A copy of the Indiana registration for the vehicle
<input checked="" type="checkbox"/>	Copy of a valid driver's license
<input checked="" type="checkbox"/>	Copy of an Indiana Driver's Record and/or equivalent of whatever State has issued the applicant his/her driver's license
<input checked="" type="checkbox"/>	Proof of an independent safety inspection of all vehicles to be used in the business (form included with app)
<input checked="" type="checkbox"/>	Proof of insurance in accordance with the limits described in Section 4.28.090 of the Bloomington Municipal Code: <ul style="list-style-type: none"> • Personal Injury: \$100,000.00 per occurrence and \$300,000 in the aggregate • Property Damage: \$25,000.00 per occurrence and \$50,000.00 in the aggregate
<input checked="" type="checkbox"/>	Release of liability wherein the Applicant agrees to indemnify and hold harmless the City of Bloomington for losses or expenses arising out of the operation of his/her business (included with application)
<input checked="" type="checkbox"/>	A copy of the business's registration with the Indiana Secretary of State.
<input checked="" type="checkbox"/>	A copy of the Employer ID number
<input checked="" type="checkbox"/>	A signed copy of the Prohibited Location Agreement (included with application)
<input checked="" type="checkbox"/>	A signed copy of the Standards of Conduct Agreement (included with application)
<input type="checkbox"/>	Fire inspection (if required)
<input checked="" type="checkbox"/>	Picture of truck or trailer
<input checked="" type="checkbox"/>	Copy of all applicable permits required by the Monroe County Health Department, including but not limited to a Food Service Establishment License or a Certified Food Handler License.

For City Of Bloomington Use Only

Received in ESD	Received By:	Date Approved:	Approved By:
SEP 03 2024	<i>[Signature]</i>	9/4/24	<i>[Signature]</i>



State Form 48099 (R5/7-17)
Approved by State Board of
Accounts 2017

INDIANA CERTIFICATE OF VEHICLE REGISTRATION

CLASS 13	AGE 1	ISSUE DATE 01/30/24	PUR DATE 02/01/23	COUNTY 55 - MORGAN	TP R	PL YR 24	PLATE ZYC356	PL TP SP	WEIGHT 11	PR YR 23	LS N	TYPE SP	PRIOR YR PL ZYC356
EXPIRATION DATE 01/31/25	MUNICIPALITY NONE OF THE ABOVE			VEHICLE YEAR 23	MAKE GMC	MODEL SAV	VEHICLE IDENTIFICATION NUMBER 1GD07RFP7P1107373			TYPE VA	COLOR PLE/		
CURRENT YEAR TAX	EX TAX 260.00	EX CREDIT 0.00	DAV CREDIT 0.00	NET EX TAX 260.00	CO. WHEEL/SUR 25.00	MUN. WHEEL/SUR 0.00	STATE REG FEE 45.35	ADMIN FEE 0.00	TOTAL 330.35				
PRIOR YEAR TAX	EX TAX 0.00	EX CREDIT 0.00	DAV CREDIT 0.00	NET EX TAX 0.00	CO. WHEEL/SUR 0.00	MUN. WHEEL/SUR 0.00	STATE REG FEE 0.00	ADMIN FEE 0.00	TOTAL 0.00				
REGISTRATION LICENSE TYPE IN GOD WE TRUST NEW FORMAT HIGH DIGIT TRUCK 11,000													

INSTRUCTIONS FOR APPLYING PLATE DECA

1. Verify plate number and decal match.
2. Do not attempt to apply decal if temperature is below -10 degrees Fahrenheit.
3. Clean and dry plate before affixing new decal.
4. Remove decal by bending corner of card under decal along dotted line.
5. Next, lift up corner of decal where card is creased.
6. Decal is fragile peel decal off slowly.
7. Place decal in the upper right corner of your license plate.
8. Rub or press firmly around edges of decal after application.



Legal Address
4610 HACKER CREEK RD
MARTINSVILLE IN 46151-9433

STOHLER PROPERTY MANAGEMENT LL



0202

**4610 HACKER CREEK RD
MARTINSVILLE IN 46151-9433**



000.00.000

3

PEEL



REGISTERED RETAIL MERCHANT CERTIFICATE

INDIANA DEPARTMENT OF REVENUE
100 N SENATE AVE
INDIANAPOLIS IN 46204-2253
(317) 232-2240

KONA ICE OF BLOOMINGTON INCORPORATED
4610 HACKER CREEK RD
MARTINSVILLE IN 46151-9433

FEIN 81-2690958
LOC ID 0158439155-001
ISSUED December 02, 2021
EXPIRES December 31, 2023

IS AUTHORIZED TO COLLECT INDIANA RETAIL SALES TAX AT THE ADDRESS ABOVE IF DIFFERENT FROM BELOW.

THIS LICENSE:
IS NOT TRANSFERABLE TO ANY OTHER PERSON.
IS NOT SUBJECT TO REBATE.
IS VOID IF ALTERED.

KONA ICE OF BLOOMINGTON INCORPORATED
4610 HACKER CREEK RD
MARTINSVILLE IN 46151-9433

Robert J. Jenner

COMMISSIONER

MUST BE DISPLAYED BY MERCHANT IN THE LOCATION SHOWN

Background Verification Report

REQUESTED: 8/14/2024

PRINTED: 8/26/2024 12:01:25 PM

COMPLETED: 8/14/2024

APPLICANT INFORMATION

PROVIDED TO: Kona Ice of Bloomington

REQUESTED BY: Warren Stohler

ATTENTION: Kona Ice of Bloomington

PROVIDED BY: AUDI LLC

SUBJECT: STOHLER, WARREN E

SS #: XXX-XX-6423

ADDRESS: 4610 HACKER CREEK RD

DOB: 10/02/1953

MARTINSVILLE, IN 46151

RESULTS DETAILS

DRIVING HISTORY

Driver's License #: 8914850785

State Issued: IN

Reported Driver's License #: 8914850785

INDIANA DRIVER RECORD REPORT

REPORT SEARCH DATE -> 08/14/2024

LICENSE NAME/ADDRESS

DRIVER DESCRIPTION

STOHLER, WARREN EDWARD
4610 HACKER CREEK RD
MARTINSVILLE, IN 46151-9433

DOB/SS# | GENDER/RACE | HT/WT | EYES/H
===== | ===== | ===== | ===== | =====
10/02/53 | M | 511 | BLUE |
| | 195 | GRAY |

LICENSE NUMBER	ORIG. ISSUED	ISSUED	EXPIRES	CLASS	STATUS
8914850785		11/01/2019	10/02/2026	OPERATOR	VALID (DUPL

POINTS: 0

LIC TYP: PERSONAL

STATUS: VALID (DUPLICATE LICENSE)

RESTRICTIONS: CORRECTIVE LENSES

ENDORSEMENTS: FOR HIRE - NON-CMV ONLY

*** MISCELLANEOUS AND STATE SPECIFIC INFORMATION ***

** REINSTATEMENT FEE: \$0.00

** NO INSURANCE FEE: \$0.00

EXPIRATION DATES IN THIS DOCUMENT MAY HAVE BEEN EXTENDED PURSUANT TO EXECUTIVE
 ** OR LEGISLATIVE ACTION OF THE ISSUING JURISDICTION RELATED TO COVID-19.
 ** PLEASE CONSULT WITH THE JURISDICTION FOR FURTHER DETAILS.
 ** MAILING 4610 HACKER CREEK RD MARTINSVILLE IN 46151-9433
 ** MAILING 4610 HACKER CREEK RD MARTINSVILLE IN 46151-9433
 ** MAILING 6280 S 625 W PENDLETON IN 46064-8972
 ** MAILING 6280 S 625 W PENDLETON IN 46064-8972
 ** MAILING 6280 S 625 W PENDLETON IN 46064-8972
 ** MAILING 15 S CREEDMOOR WAY ANDERSON IN 46011-9019
 ** MAILING 15 S CREEDMOOR WAY ANDERSON IN 46011-9019
 ** MAILING 1777 RACCOON WAY PENDLETON IN 46064-8605

NO REPORTABLE INCIDENTS FOUND

=====
 *** DRIVING RECORD HISTORY ***

Type	Viol/Susp	Conv/Reins	Post/Expir	Description	Pts
----	-----	-----	-----	-----	----
OTHE	10/03/2019	10/02/2026	PERSONAL	Sub Type.....: HISTORICAL LICENSE EN.....: FOR HIRE - NON-CMV ONLY RS.....: CORRECTIVE LENSES Class.....: OPERATOR Record Status.....: VALID (RENEW LICENSE)	
OTHE	08/14/2013	10/02/2019	PERSONAL	Sub Type.....: HISTORICAL LICENSE RS.....: CORRECTIVE LENSES Class.....: CHAUFFEUR Record Status.....: EXPIRED (RENEW LICENSE)	
OTHE	10/03/2012	10/02/2016	PERSONAL	Sub Type.....: HISTORICAL LICENSE RS.....: CORRECTIVE LENSES Class.....: OPERATOR (4 YEAR) NONPROB Record Status.....: EXPIRED (RENEW CDL LICENSE)	
OTHE	11/27/2010	10/02/2012	COMMERCIAL	Sub Type.....: HISTORICAL LICENSE EN.....: PASSENGER TRANSPORT, DOUBLE/TRI RS.....: CORRECTIVE LENSES Class.....: B - VEH GCWR=>26,001 LBS W/TOWE Record Status.....: PENDING (AMEND CDL LICENSE)	
OTHE	10/01/2008	10/02/2012	COMMERCIAL	Sub Type.....: HISTORICAL LICENSE EN.....: PASSENGER TRANSPORT, DOUBLE/TRI RS.....: CORRECTIVE LENSES Class.....: B - VEH GCWR=>26,001 LBS W/TOWE Record Status.....: EXPIRED (RENEW CDL LICENSE)	
OTHE	11/21/2006	10/02/2008	COMMERCIAL		

Sub Type.....: HISTORICAL LICENSE
EN.....: PASSENGER TRANSPORT, DOUBLE/TRI
Class.....: B - VEH GCWR=>26,001 LBS W/TOWE
Record Status.....: EXPIRED (AMEND CDL LICENSE)

OTHE 03/02/2004 10/02/2008 COMMERCIAL

Sub Type.....: HISTORICAL LICENSE
EN.....: PASSENGER TRANSPORT, DOUBLE/TRI
RS.....: CORRECTIVE LENSES
Class.....: B - VEH GCWR=>26,001 LBS W/TOWE
Record Status.....: EXPIRED (RENEW LICENSE)

PERM 02/18/2004 08/31/2004 COMMERCIAL PERMIT

Permit Class.....: A - PERMIT FOR COMB VEH GCWR=>2
Permit Status.....: EXPIRED (AMEND CDL LICENSE)
Permit Restrictions.: CORRECTIVE LENSES
Permit Endorsements.: PASSENGER TRANSPORT, DOUBLE/TRI

OTHE 02/16/2004 10/02/2004 PERSONAL

Sub Type.....: HISTORICAL LICENSE
Class.....: OPERATOR
Record Status.....: EXPIRED (DUPLICATE LICENSE)

PERM 02/14/2004 08/31/2004 COMMERCIAL PERMIT

Permit Class.....: B - PERMIT FOR VEH GCWR=>26,001
Permit Status.....: EXPIRED (RENEW CDL PERMIT)
Permit Restrictions.: CORRECTIVE LENSES
Permit Endorsements.: PASSENGER TRANSPORT

OTHE 10/12/2000 10/02/2004 PERSONAL

Sub Type.....: HISTORICAL LICENSE
Class.....: OPERATOR
Record Status.....: EXPIRED (RENEW LICENSE)

OTHE 12/02/1996 10/31/2000 PERSONAL

Sub Type.....: HISTORICAL LICENSE
RS.....: CORRECTIVE LENSES
Class.....: OPERATOR
Record Status.....: EXPIRED (RENEW LICENSE)

*** END OF RECORD ***

08/14/24 07:07:04 AM

DISCLAIMER

Users should consult State and Federal laws before using this information in making decisions on hiring or firing of employees. By requesting any search, you certify that you assume full responsibility for compliance with the legal restrictions, terms of use, and applicable laws. You also agree to use all information provided to you that does not violate the Gramm-Leach-Bliley Act (GLBA), Fair Credit Reporting Act, 15 U.S.C. sec. 1681 et seq., (FCRA), Federal Trade Commission interpretations of the Fair Credit Reporting Act, and similar state statutes.

Permissible Use / Summary of Your Rights Under the Fair Credit Report

Permissible Use

Users should consult State and Federal laws before using this information in making decisions on hiring or firing of employees. By requesting any search, you certify that you assume full responsibility for compliance with the legal restrictions, terms of use, and applicable laws. You also agree to use all information provided to you that does not violate the Gramm-Leach-Bliley Act (GLBA), Fair Credit Reporting Act, 15 U.S.C. sec. 1681 et seq., (FCRA), Federal Trade Commission interpretations of the Fair Credit Reporting Act, and similar state statutes.

Para información en español, visite www.consumerfinance.gov/learnmore o escriba a la Consumer Financial Protection Bureau, 1700 G Street NW, Washington, DC 20552.

A Summary of Your Rights Under the Fair Credit Reporting Act

The federal Fair Credit Reporting Act (FCRA) promotes the accuracy, fairness, and privacy of information in the files of consumer reporting agencies. There are many types of consumer reporting agencies, including credit bureaus and specialty agencies (such as agencies that sell information about check writing histories, medical records, and rental history records). Here is a summary of your major rights under FCRA. For more information, including information about additional rights, go to www.consumerfinance.gov/learnmore or write to: Consumer Financial Protection Bureau, 1700 G Street NW, Washington, DC 20552.

- You must be told if information in your file has been used against you. Anyone who uses a credit report or another type of consumer report to deny your application for credit, insurance, or employment - or to take another adverse action against you - must tell you, and must give you the name, address, and phone number of the agency that provided the information.
- You have the right to know what is in your file. You may request and obtain all the information about you in the files of a consumer reporting agency (your "file disclosure"). You will be required to provide proper identification, which may include your Social Security number. In many cases, the disclosure will be free. You are entitled to a free file disclosure if:
 - o a person has taken adverse action against you because of information in your

credit report,

- o you are the victim of identity theft and place a fraud alert in your file;
- o your file contains inaccurate information as a result of fraud;
- o you are on public assistance;
- o you are unemployed but expect to apply for employment within 60 days.

In addition, all consumers are entitled to one free disclosure every 12 months upon

request from each nationwide credit bureau and from nationwide specialty consumer

reporting agencies. See www.consumerfinance.gov/learnmore for additional information.

- You have the right to ask for a credit score. Credit scores are numerical summaries of your credit-worthiness based on information from credit bureaus. You may request a credit score from consumer reporting agencies that create scores or distribute scores used in residential real property loans, but you will have to pay for it. In some mortgage transactions, you will receive credit score information for free from the mortgage lender.

- You have the right to dispute incomplete or inaccurate information. If you identify information in your file that is incomplete or inaccurate, and report it to the consumer reporting agency, the agency must investigate unless your dispute is frivolous. See www.consumerfinance.gov/learnmore for an explanation of dispute procedures.

- Consumer reporting agencies must correct or delete inaccurate, incomplete, or unverifiable information. Inaccurate, incomplete, or unverifiable information must be removed or corrected, usually within 30 days. However, a consumer reporting agency may continue to report information it has verified as accurate.

- Consumer reporting agencies may not report outdated negative information. In most cases, a consumer reporting agency may not report negative information that is more than seven years old, or bankruptcies that are more than 10 years old.

- Access to your file is limited. A consumer reporting agency may provide information about you only to people with a valid need - usually to consider an application with a creditor, insurer, employer, landlord, or other business. The FCRA specifies those with a valid need for access.

- You must give your consent for reports to be provided to employers. A consumer reporting agency may not give out information about you to your employer, or a potential employer, without your written consent given to the employer. Written consent is not required in the trucking industry. For more information, go to www.consumerfinance.gov/learnmore.

- You may limit "prescreened" offers of credit and insurance you get based on

and

insurance must include a toll-free phone number you can call if you choose to remove

your name and address from the lists these offers are based on. You may opt out with the

nationwide credit bureaus at 1-800-XXX-XXXX.

- The following FCRA right applies with respect to nationwide consumer reporting agencies:

CONSUMERS HAVE THE RIGHT TO OBTAIN A SECURITY FREEZE

You have a right to place a "security freeze" on your credit report, which will prohibit a consumer reporting agency from releasing information in your credit report without your express authorization. The security freeze is designed to prevent

credit, loans, and services from being approved in your name without your consent.

However, you should be aware that using a security freeze to take control over who gets

access to the personal and financial information in your credit report may delay, interfere

with, or prohibit the timely approval of any subsequent request or application you make

regarding a new loan, credit, mortgage, or any other account involving the extension of

credit.

As an alternative to a security freeze, you have the right to place an initial or extended

fraud alert on your credit file at no cost. An initial fraud alert is a 1-year alert that is

placed on a consumer's credit file. Upon seeing a fraud alert display on a consumer's

credit file, a business is required to take steps to verify the consumer's identity before

extending new credit. If you are a victim of identity theft, you are entitled to an extended

fraud alert, which is a fraud alert lasting 7 years.

A security freeze does not apply to a person or entity, or its affiliates, or collection

agencies acting on behalf of the person or entity, with which you have an existing

account that requests information in your credit report for the purposes of reviewing or

collecting the account. Reviewing the account includes activities related to account

maintenance, monitoring, credit line increases, and account upgrades and enhancements.

- You may seek damages from violators. If a consumer reporting agency, or, in some

cases, a user of consumer reports or a furnisher of information to a consumer reporting

agency violates the FCRA, you may be able to sue in state or federal court.

- Identity theft victims and active duty military personnel have additional rights. For

States may enforce the FCRA, and many states have their own consumer reporting laws.

In some cases, you may have more rights under state law. For more information, contact

your state or local consumer protection agency or your state Attorney General.

For

information about your federal rights, contact:

information about your federal rights, contact:

4

TYPE OF BUSINESS: CONTACT:

1.a. Banks, savings associations, and credit unions with total assets of over \$10 billion and their affiliates

b. Such affiliates that are not banks, savings associations, or credit unions also should list, in addition to the CFPB:

a. Consumer Financial Protection Bureau

1700 G Street NW

Washington, DC 20552

b. Federal Trade Commission

Consumer Response Center

600 Pennsylvania Avenue NW

Washington, DC 20580

(877) 382-4357

2. To the extent not included in item 1 above:

a. National banks, federal savings associations, and federal branches and federal agencies of foreign banks

b. State member banks, branches and agencies of foreign banks (other than federal branches, federal agencies, and Insured State Branches of Foreign Banks), commercial lending companies owned or controlled by foreign banks, and organizations operating under section 25 or 25A of the Federal Reserve Act.

c. Nonmember Insured Banks, Insured State Branches of Foreign Banks, and insured state savings associations

d. Federal Credit Unions

a. Office of the Comptroller of the Currency

Customer Assistance Group

P.O. Box 53570

Houston, TX 77052

b. Federal Reserve Consumer Help Center

P.O. Box 1200

Minneapolis, MN 55480

c. Division of Depositor and Consumer Protection

National Center for Consumer and Depositor Assistance

Federal Deposit Insurance Corporation

1100 Walnut Street, Box #11

Kansas City, MO 64106

d. National Credit Union Administration

Office of Consumer Financial Protection

1775 Duke Street

Alexandria, VA 22314

3. Air carriers Assistant General Counsel for Office of Aviation Protection

1200 New Jersey Avenue SE

Washington, DC 20590

4. Creditors Subject to the Surface Transportation Board Office of Public Assistance, Governmental Affairs, and Compliance

Surface Transportation Board

395 E Street SW

Washington, DC 20423

5. Creditors Subject to the Packers and Stockyards Act, 1921

Nearest Packers and Stockyards Division Regional Office

6. Small Business Investment Companies Associate Administrator, Office of Capital Access

United States Small Business Administration

409 Third Street SW, Suite 8200

Washington, DC 20416

7. Brokers and Dealers Securities and Exchange Commission

100 F Street NE

Washington, DC 20549

8. Institutions that are members of the Farm Credit System

Farm Credit Administration

1501 Farm Credit Drive

McLean, VA 22102-5090

9. Retailers, Finance Companies, and All Other Creditors Not Listed Above

Federal Trade Commission

Consumer Response Center

600 Pennsylvania Avenue NW

Washington, DC 20580

(877) 382-4357

CITY OF BLOOMINGTON

MOBILE VENDOR INSPECTION CHECK SHEET

COMPANY PERFORMING INSPECTION ARNOLD TIRE CO, INC
INSPECTOR'S NAME DON ARNOLD INSPECTOR'S PHONE # 765/342-8405
DATE OF INSPECTION 8-15-24
NAME OF VENDOR _____
VEHICLE YEAR 2023 MAKE GMC MODEL SAV
VIN 1G207RFP7P1107373

	PASS	FAIL	COMMENTS
LIGHTS (Front & Rear)	✓	_____	_____
FLASHERS	✓	_____	_____
REFLECTORS	✓	_____	_____
HORN	✓	_____	_____
WINDSHIELD WIPERS	✓	_____	_____
MIRRORS	✓	_____	_____
SEATBELTS	✓	_____	_____
BUMPER HEIGHT	✓	_____	_____
ALL WINDOWS	✓	_____	_____
MUFFLER	✓	_____	_____
TIRES	✓	_____	_____
BRAKES	✓	_____	FRONT 90% REAR 90%
DOORS	✓	_____	_____
GENERAL CONDITION OF VEHICLE	✓	_____	_____

Attach this completed Inspection Sheet with your permit or renewal application
and remit to:

City of Bloomington
Department of Economic and Sustainable Development
401 N. Morton St.
Bloomington, Indiana 47404
812-349-3419

Additional Comments by Inspector: _____

Inspector Signature *Don Awalt*

Date: 8-15-24

**Attach this completed Inspection Sheet with your permit or renewal application
and remit to:
City of Bloomington
Department of Economic and Sustainable Development
401 N. Morton St.
Bloomington, Indiana 47404
812-349-3419**

Kerry Thomson
Mayor
CITY OF BLOOMINGTON
401 N. Morton St Suite 130
P.O. Box 100
Bloomington, Indiana 47402

DEPARTMENT OF ECONOMIC
& SUSTAINABLE DEVELOPMENT
p. 812.349.3418
f. 812.349.3520

RELEASE, HOLD-HARMLESS AND INDEMNIFICATION AGREEMENT

The undersigned, in consideration for the issuance of a license by the City of Bloomington Controller, agrees to the following:

1. The undersigned, in exchange for the issuance of a license by the City of Bloomington Controller, agrees to release, hold harmless, and forever indemnify the City of Bloomington and any and all City employees, officers, and agents from any claim or claims which may arise out of any incident connected with or in any way related to his/her issuance of a license by the City of Bloomington or his/her operation of a business which was licensed by the City of Bloomington. This includes claims for personal injury, death, property damage, and/or any other type of harm or injury.
2. The undersigned shall, and hereby does, indemnify, defend, and hold harmless the City of Bloomington and any and all City employees, officers, and agents from and against any and all actions, costs, claims, suits, losses, expenses or damages, including but not limited to attorneys' fees and court costs, arising out of the undersigned's operation of a business which has been licensed by the City of Bloomington.
3. The undersigned understands this release binds him/herself, his/her spouse, and all heirs, executors, partners, co-owners and administrators of those individuals.

The undersigned acknowledges that he/she has read this release and understands all of its terms. The undersigned signs this release voluntarily and with full knowledge of its significance.

WARREN STOKER

Name, Printed

Warren Stoker
Signature

Aug 14, 2024
Date Release Signed

Kerry Thomson
Mayor
 CITY OF BLOOMINGTON
 401 N. Morton St Suite 130
 P.O. Box 100
 Bloomington, Indiana 47402

DEPARTMENT OF ECONOMIC
 & SUSTAINABLE DEVELOPMENT
 p. 812.349.3418
 f. 812.349.3520

Prohibited Location Agreement

Bloomington Municipal Code Section 4.28.140 prohibits Mobile Vendor Units from operating in certain locations. This Agreement provides for all of the prohibited locations. Two maps are also attached to this Agreement. All signatories to this Agreement are required to review not only this Agreement, but also the attached maps prior to signing this Agreement.

As a licensed Mobile Vendor Unit, I understand and agree that I cannot and will not operate my mobile vendor unit in a manner that would violate any of the below-listed location restrictions:

- No mobile food vendor unit shall locate in any parking lot, parking space, or parking facility owned, leased or managed by the City of Bloomington unless approval has been given by the City's Board of Public Works.
- No mobile food vendor unit shall operate within fifty feet of any facade of a ground level establishment that also sells food or beverages, or operate within fifty feet of the perimeter of such an establishment's outdoor seating area, regardless of whether or not the mobile food vendor unit is currently conducting business. The distance restriction only applies from one hour before the opening time to an hour after the closing time posted by a ground level establishment on the facade of its building.
- No mobile food vendor unit shall locate in an alleyway.
- Mobile food vendor units shall be located a reasonable distance from all posted bus stops, crosswalks, driveways, alleyways, right-of-way lines of two or more intersecting streets and building entrances or walk-up windows.
- Mobile food vendor units shall only be located on private property if the private property owner has provided both the business operator and the City written permission for the mobile food vendor unit to locate on said property.
- No mobile food vendor unit shall locate within a one block radius of a Special Event unless prior approval has been granted by either the operator of the Special Event or the City's Board of Public Works.
- No mobile food vendor unit shall park on City property in violation of any City parking regulation, restriction, or ordinance. For example, if parking at one, or multiple, parking meters, the operator of the mobile food vendor unit shall feed all relevant parking meters with the required monetary amount.
- No mobile food vendor unit shall be located in a manner which would significantly impede or prevent the use of any City of Bloomington property, or which would endanger the safety or property of the public.
- No mobile food vendor unit shall be located within fifteen feet of any fire hydrant.

- No mobile food vendor shall locate within any zoning district except the following: Commercial General; Commercial Arterial; Commercial Downtown; Industrial General; Business Park; and Institutional.
- No mobile food vendor operating on private property shall displace required parking or landscaping nor block any drives, parking access aisles, fire lanes, sidewalks, or accessible routes required for the private parking by the City's zoning code.
- No mobile food vendor unit shall be located more than one foot away from the curb of the street on which it is parked.
- No mobile food vendor unit shall park near an intersection and in a manner that blocks the line-of-sight of drivers using adjacent roadways.

I, the undersigned, understand that if I locate my mobile vendor unit in any of the above-described prohibited locations or manner that I subject myself to fines and possible revocation of my Mobile Vendor Unit License, as so described in Chapter 4.28 of the Bloomington Municipal Code.

Vendor:

Name: WARREN STOHLER

Signature: Warren Stohler

Date: AUG 14, 2024

Kerry Thomson

Mayor

CITY OF BLOOMINGTON

401 N. Morton St Suite 130

P.O. Box 100

Bloomington, Indiana 47402

**DEPARTMENT OF ECONOMIC
& SUSTAINABLE DEVELOPMENT**

p. 812.349.3418

f. 812.349.3520

Standard of Conduct Agreement

Bloomington Municipal Code Section 4.28.160 provides Standards of Conduct for all Mobile Vendor Units. This Agreement provides a list of said Standards of Conduct. All signatories to this Agreement are required to review this Agreement prior to signing this Agreement.

As a licensed Mobile Vendor Unit, I understand and agree that I cannot and will not conduct business in a manner that would violate any of the Standards of Conduct noted below:

- Mobile food vendor unit operators shall conduct themselves at all times in an orderly and lawful manner, and shall not make, or cause to be made, any unreasonable noise of such volume as to be in violation of the City of Bloomington Noise Ordinance as stated in Title 14 of the Bloomington Municipal Code
- A device may not be used which would amplify sounds nor may attention be drawn to the mobile food vendor unit by an aural means or a light-producing device (examples of such devices may include, but are not meant to be limited to the following: bull horns and strobe lights
- No mobile food vendor unit may be permanently or temporarily affixed to any object, including but not limited to buildings, trees, telephone poles, streetlight poles, traffic signal poles or fire hydrants
- No mobile food vendor unit may be used to advertise any product which is not authorized to be sold from that unit
- Each mobile food vendor unit shall be limited to one sandwich board sign that meets the provisions of Section 20.05.086 of the Bloomington Municipal Code regardless of the zoning district in which it locates, provided a sign permit is obtained from the City's Planning and Transportation Department
- No mobile food vendor unit may make use of any public or private electrical outlet while in operation
- Each mobile food vendor unit shall protect against littering and shall have both an adequate trash receptacle and a separate receptacle for recyclable materials:
 - The trash and recyclable receptacles shall be emptied sufficiently often to allow disposal of litter and waste by the public at any time;
 - The trash and recyclable receptacles on the mobile food vendor unit shall not be emptied into trash or recyclable receptacles owned by the City of Bloomington;
 - Liquid from the mobile food vendor unit shall not be discharged on or in a City sewer or drain or elsewhere on City property, nor on private property without the express written consent of the owner thereof;

- Before leaving any location each mobile food vendor unit shall first pick up, remove and dispose of all trash, refuse and/or recyclable materials, including products spilled on the ground within twenty feet of the mobile food vendor unit.
- No mobile food vendor unit shall expose any pedestrian to any undue safety or health hazards nor shall it be maintained so as to create a public nuisance
- Each mobile food vendor unit shall be maintained free and clear of dirt, and finishes shall not be chipped, faded or unduly marred
- Foods or beverages which present a substantial likelihood that liquid matter or particles will drop to the street or sidewalk during the process of carrying or consuming the food or beverage shall be sold in proper containers so as to avoid falling to the street or sidewalk
- Mobile food vendor units which utilize a grill or device that may result in a spark, flame or fire shall adhere to the following additional standards:
 - Be placed approximately 20 feet from a building or structure;
 - Provide a barrier between the grill or device and the general public;
 - The spark, flame or fire shall not exceed 12 inches in height;
 - A fire extinguisher shall be within reaching distance of the mobile food vendor unit operator at all times;
- Mobile food vendor unit operators shall be required to obey the commands of law enforcement officers or fire officials with respect to activity carried out inside of the City's jurisdictional limits, including, where possible, the removal of the mobile food vendor unit and cessation of such sales
- No mobile food vendor unit shall ever be left unattended
- Mobile food vendor units shall not be stored, parked or left overnight on any City property
- All mobile food vendor units which are food service establishments as defined by Title 10.17 of the Bloomington Municipal Code shall install an approved grease interceptor or grease trap. Foods, oils and greases shall never be discharged into the City's sewer or storm drains
- All mobile food vendor unit operators are required to collect and pay all applicable and appropriate sales taxes
- No mobile food vendor shall provide customer seating unless approval has been provided by the City's Board of Public Works and the City's Planning and Transportation Department
- All mobile food vendors shall comply with the lighting standards found in Chapter 20.05 of the Bloomington Municipal Code
- All mobile food vendors shall comply with the vision clearance standards found in Chapter 20.05 of the Bloomington Municipal Code
- No mobile food vendor shall have a drive-thru
- The decibels of any generator(s) associated with a mobile food vendor unit shall not exceed "70dBA".
 - Such noise measurement shall be made at a height of at least four (4) feet above the ground and at a point approximately twenty-five (25) feet away from where the

noise is being emitted on a sound level meter operated on the "A" weighting network (scale).

- No person other than the operators shall be within twenty-five (25) feet of the sound level meter during the sample period.
- Sound measurements shall be conducted at that time of day or night when the relevant noise source is emitting sound.
- The sound level measurement shall be determined as follows:
 - Calibrate the sound level meter within one (1) hour before use.
 - Set the sound level meter on the "A" weighted network at slow response.
 - Set the omnidirectional microphone in an approximately seventy degree position in a location which complies with subsections (1) and (2) herein. The operator of the sound level meter shall face the noise source and record the meter's instantaneous response.
 - Recalibrate the sound level meter after use.
- It shall be unlawful for any person to interfere, through the use of sound or otherwise, with the taking of sound level measurement.

I, the undersigned, understand that if I conduct business in violation of any the above described standards of conduct that I subject myself to fines and possible revocation of my Mobile Vendor Unit License, as so described in Chapter 4.28 of the Bloomington Municipal Code.

Vendor:

Name: WARREN STOHLEN

Signature: Warren Stohlen

Date: AUG 14, 2024

<u>Festival General Contact Information</u>			
<u>Event</u>	<u>Dates</u>	<u>Contact Person</u>	<u>Phone Number</u>
Bloomington Farmers' Market	Every Saturday, April – November	Clarence Boone, Market Coordinator	(812) 349-3700
Strawberry Festival	Mid-May	Christina Hurlow, Boys & Girls Club	812-287-8771
Taste of Bloomington	Mid-June	Talisha Coppock, Co-Director	(812) 336-3681
Arts Fair on the Square	Mid-August	Lee Burckes, Event Manager	(812) 334-1188
4th of July Parade	July 4th	Talisha Coppock,	(812) 349-3700
4th Street Festival	Early September	4th Street Committee	(812) 335-3814
Lotus World Music and Arts Festival	Late September	Lotus Office	(812) 336-3959
Bloomington Holiday Market	Final Farmers' Market	Clarence Boone, Market Coordinator	(812) 349-3700
Canopy of Lights	Friday after Thanksgiving	Talisha Coppock	(812) 336-3681
<u>Itinerant Merchant Contact Information</u>			
<u>Permit Issuer</u>	<u>Location</u>	<u>Contact Person</u>	<u>Phone Number</u>
Monroe County Health Department (Food Handler Permit)	119 W. 7th St. Bloomington, IN	Sylvia Garrison, Administrator	(812) 349-2543
Bloomington Board of Public Works (Conducting Business in Public Right-of-Way)	401 N. Morton St. Suite 150 Bloomington, IN	Jane Kupersmith, Economic & Sustainable Development	(812) 349-3419
Bloomington Parks and Recreation Department (Conducting Business on City of Bloomington Parks Property)	401 N. Morton St. Suite 250 Bloomington, IN	Kim Clapp, Office Manager	(812) 349-3700
Bloomington Fire Department (Conducting Business that will produce any type of spark/fire hazard)	300 E. 4th St. Bloomington, IN	Fire Administration	(812) 332-9763



GOURMET SHAVED **KONA ICE** Krafted

KONA ICE
Krafted
GOURMET SHAVED ICE

KONA ICE
Krafted
0-MILES →

WIN UP TO \$1000 CASH PRIZE WITH THIS GIVEBACK
\$2
MILLION
DOLLAR
GIVEBACK

BOOK KONA
WWW.KONA-ICE.COM
FUNDRAISER SCHOOL
FESTIVAL DAYCARE
BIG EVENT WORKPLACE
SPORTS TEAM PARTY

FLAVORWAVE

PIACH POINT
PIACH POINT

Mobile Food Service Establishment License Monroe County Health Department

This is to certify that:

Kona Ice Unit #3
StohlerProperty Management LLC
190 N. Sycamore
Martinsville, IN 46151

Having complied with the rules and regulations of the Monroe County Health Department as authorized by the Indiana Administrative Code and the Board of Commissioners of Monroe County, Indiana, is hereby authorized to operate a Food Service Establishment at the above location for the calendar year.



Issued:
3/8/2024

2024

By

Monroe County Health Officer

NON-NEGOTIABLE AND NOT TRANSFERABLE

PERMIT EXPIRES FEBRUARY 28, 2025

RESOLUTION 2024-063
CITY OF BLOOMINGTON
BOARD OF PUBLIC WORKS
Mobile Vendor in Public Right of Way
Kona Ice of Bloomington - Truck 3

WHEREAS, the Board of Public Works is empowered by Indiana Code § 36-9-6-2 to supervise the streets, alleys, sewers, public grounds, and other property of the City of Bloomington (“City”);

WHEREAS, Kona Ice of Bloomington - Truck 3 (“Vendor”), is seeking a Mobile Vendor License under Bloomington Municipal Code 4.28;

WHEREAS, the issuance of a Mobile Vendor License under Bloomington Municipal Code 4.28 requires Vendor to submit documentation to the City—set forth at Bloomington Municipal Code 4.28.050—including an independent safety inspection, an open burn permit issued by the City of Bloomington Fire Department, and all applicable permits required by the Monroe County Health Department;

WHEREAS, Vendor has agreed to the Standards of Conduct set forth in Bloomington Municipal Code 4.28.160 and signed the Release, Hold-Harmless, and Indemnification Agreement as required by Bloomington Municipal Code 4.28.090;

WHEREAS, Vendor desires to be able to use “City property” as defined in Bloomington Municipal Code 4.28.010, which includes public on-street parking, on a temporary and transient basis for the purpose of selling food via a mobile kitchen, food truck or trailer; and

WHEREAS, under the Bloomington Municipal Code, approval to use public on-street parking and sidewalks is provided by the Board of Public Works via resolution;

NOW, THEREFORE, BE IT RESOLVED BY THE BOARD OF PUBLIC WORKS THAT:

1. Vendor has permission to use on-street public parking and sidewalks, on a temporary and transient basis, for the purposes of selling food via a mobile kitchen, food truck or trailer for 1 year beginning 9/12/2024, and ending on 9/12/2025.

2. For the avoidance of doubt, this Resolution is not the Business License referenced by Chapter 4.28 of the Bloomington Municipal Code. Thus, Vendor must ensure that all necessary documentation has been submitted to the City of Bloomington Controller and that the Business License has been issued by the City of Bloomington Controller before utilizing the permission to use on-street public parking and sidewalks granted in the paragraph above. Operating a mobile vendor without a business license is a violation of Bloomington Municipal Code 4.28.180(a)(1), and would subject Vendor to a fine of \$2,500 for the first offense.

3. For the avoidance of doubt, the following conditions—which in some instances may mirror those that exist under Title 4.28 of the Bloomington Municipal Code—attach to this approval:

- a. Vendor agrees to maintain a clear five-foot path for pedestrians on the sidewalk at all times.
- b. Vendor will have obtained a valid Mobile Vendor license issued by the City of Bloomington Controller prior to operation on City property, and will maintain a valid Mobile Vendor license throughout the term of Vendor’s operation on City property.
- c. Vendor may locate his business in a public parking space within a reasonable time, no more than one hour, before the vendor begins selling food to persons. Vendor must still comply with all other restrictions regarding its location in a public parking space.

- d. Vendor shall remove his business from a public parking space within a reasonable time, no more than one hour, following the time the vendor has stopped selling food to persons. Vendor must still comply with all other restrictions regarding its location in a public parking space.
- e. Vendor will comply with all other laws, ordinances, rules and regulations in effect at the time it conducts their business, including, but not limited to: (1) Bloomington Municipal Code 4.28 (Mobile Vendors), and (2) all City parking regulations, restrictions, and ordinances.
- f. Vendor is prohibited from operating within a one block radius of a Special Event, unless prior approval has been granted by either the operator of the Special Event or the City's Board of Public Works. The Board of Public Works is not required to provide specific notice to Vendor when it recognizes a Special Event. The following are Special Events that have been recognized by the Board of Public Works:
 - 1) City of Bloomington Farmers' Market;
 - 2) City of Bloomington Holiday Market;
 - 3) The Taste of Bloomington;
 - 4) Lotus World Music and Arts Festival;
 - 5) The Fourth Street Festival;
 - 6) Arts Fair on the Square;
 - 7) Strawberry Festival;
 - 8) Canopy of Lights;
 - 9) Fourth of July Parade; and
 - 10) Any other special events approved by the City Controller.

ADOPTED THIS THE 10th DAY OF SEPTEMBER, 2024.

BOARD OF PUBLIC WORKS:

Kyla Cox Deckard, President

Elizabeth Karon, Vice President

James Roach, Secretary

ALL TERMS AND CONDITIONS CONTAINED IN THIS RESOLUTION 2024-063 ARE ACCEPTABLE AND AGREED TO BY VENDOR:

Warren Stohler

Date: _____

REGISTER OF PAYROLL CLAIMS
Board: Board of Public Works Claim Register

Date:	Type of Claim	FUND	Description	Bank Transfer	Amount
9/6/2024	Payroll				585,289.80
					<u>585,289.80</u>

ALLOWANCE OF CLAIMS

We have examined the claims listed on the foregoing register of claims, consisting of 1
claim, and except for the claims not allowed as shown on the register, such claims are hereby allowed in the
total amount of \$ 585,289.80

Dated this 10th day of September year of 2024.

Kyla Cox Deckard, President Elizabeth Karon, Vice President James Roach, Secretary

I hereby certify that each of the above listed voucher(s) or bill(s) is (are) true and correct and I have audited same in accordance with IC 5-11-10-1.6.

Fiscal Officer _____



Board of Public Works Staff Report

Project/Event: Approve Addendum 4 to Preliminary Engineering Contract with WSP USA for Neighborhood Greenway Projects

Petitioner/Representative: Engineering Department

Staff Representative: Neil Kopper, Senior Project Engineer

Date: 9/10/2024

Report: This contract contains services to complete preliminary engineering tasks for multiple neighborhood greenway projects as prioritized in the City’s Transportation Plan. WSP USA is currently under contract with an overall not-to-exceed amount of \$400,000 for design efforts divided into Task Orders that require individual fee amounts and approvals. This Addendum 4 contains Task Order 3 which includes services to complete detailed design for the Thornton/Arden neighborhood greenways connecting from the intersection of Olive Street at Hillside Drive to the intersection of Arden Drive at High Street. The not-to-exceed amount for Task Order 3 is \$44,975. The existing contract amount of \$400,000 does not change with this addendum.

<u>Project Approvals Timeline</u>		
<u>Approval Type</u>	<u>Status</u>	<u>Date</u>
Funding Approval	N/A	--
Design Services Contract	Approved	5/21/2024*
Task Order 1	Approved	5/21/2024*
Task Order 2	Approved	12/19/2023**
Task Order 3	Current Item	9/10/2024
Construction Inspection Contract	N/A	--
Construction Contract	Future	TBD

*Originally approved 12/22/2020, modified 12/19/2023

**Originally approved 8/30/2022, modified 12/19/2023

City of Bloomington Contract and Purchase Justification Form

Vendor: WSP USA

Contract Amount: \$400,000

This form should be completed and attached to the contract documents and forwarded to the Legal Department Attorney assigned to your Department. Contracts will not be approved by the Controller if a completed form is not included with the contract documents.

PURCHASE INFORMATION

1. Check the box beside the procurement method used to initiate this procurement: (Attach a quote or bid tabulation if applicable)

<input type="checkbox"/> Request for Quote (RFQ)	<input type="checkbox"/> Request for Proposal (RFP)	<input type="checkbox"/> Sole Source	<input type="checkbox"/> Not Applicable (NA)
<input type="checkbox"/> Invitation to Bid (ITB)	<input checked="" type="checkbox"/> Request for Qualifications (RFQu)	<input type="checkbox"/> Emergency Purchase	

2. List the results of procurement process. Give further explanation where requested. Yes No

# of Submittals: 2	Yes	No		Yes	No
Met city requirements?	<input checked="" type="checkbox"/>	<input type="checkbox"/>	Was the lowest cost selected? (If no, please state below why it was not.)	<input type="checkbox"/>	<input checked="" type="checkbox"/>
Met item or need requirements?	<input checked="" type="checkbox"/>	<input type="checkbox"/>		Qualifications-based selection based on responses to RFQ.	
Was an evaluation team used?	<input checked="" type="checkbox"/>	<input type="checkbox"/>			
Was scoring grid used?	<input checked="" type="checkbox"/>	<input type="checkbox"/>			
Were vendor presentations requested?	<input type="checkbox"/>	<input checked="" type="checkbox"/>			

3. State why this vendor was selected to receive the award and contract:

WSP was selected for this contract based on an evaluation of their response to an RFQ.

Neil Kopper

Senior Project Engineer

Engineering

Print/Type Name

Print/Type Title

Department

TASK ORDER NO. 3
TO
TASK-ORDER BASED PROFESSIONAL SERVICES AGREEMENT
BETWEEN
WSP USA INC.
AND
CITY OF BLOOMINGTON, INDIANA

Client: City of Bloomington
Project Name: Bloomington Neighborhood Greenways
Project No. 30900699

WSP USA Inc. (“WSP”) and the City of Bloomington (“Client”) entered into an Agreement for Consulting Services (the “Agreement”) for the performance of **preliminary engineering** services pursuant to Task Orders. All terms and conditions of the Agreement, including all exhibits and amendments thereto, and all documents and terms incorporated therein, are by this reference incorporated into this Task Order for all purposes as if fully set forth, and shall govern the parties hereto.

This Task Order, effective upon execution by both parties, constitutes WSP’s Notice to Proceed with performance of the Services described herein, in accordance with the terms hereof.

- 1. Task Order Services.** WSP shall perform the Services set forth in Exhibit 1, Scope of Services, attached hereto and by this reference incorporated herein and made a part hereof for all purposes.

- 2. Compensation.** WSP shall be compensated for performance of the Services on a time and materials basis, in an amount not-to-exceed **FORTY-FOUR THOUSAND NINE HUNDRED SEVENTY-FIVE AND NO/100 DOLLARS (\$44,975)**, according to the rate schedules contained in Exhibit 2A, attached hereto and by this reference incorporated herein and made a part hereof for all purposes. The fee breakdown is shown in Exhibit 2B.

- 3. Schedule.** WSP shall perform the Services, including submittal of all deliverables, if any, in accordance with the Schedule stipulated in Exhibit C of the Agreement or in Exhibit 3, attached hereto and incorporated herein and made a part hereof for all purposes.

City of Bloomington
Board of Public Works

WSP USA INC.

By: _____
Kyla Cox Deckard, President

Patrick McCallister, Local Business Leader

By: _____
Elizabeth Karon, Vice President

By: _____
James Roach, Secretary

By: _____
Kerry Thomson, Mayor

EXHIBIT 1 - SCOPE OF SERVICES
Thornton Drive to Arden Drive Designs

The City of Bloomington has requested that WSP USA Inc. (WSP) perform design services for a portion of the Neighborhood Greenways in Bloomington, Indiana. The project limits, shown in Exhibit 1a, are as follows:

1. Olive Street from Hillside Drive to Thornton Drive
2. Thornton Drive from Olive Street to Oxford Drive
3. Oxford Drive from Thornton Drive to Arden Drive
4. Arden Drive from Oxford Drive to High Street

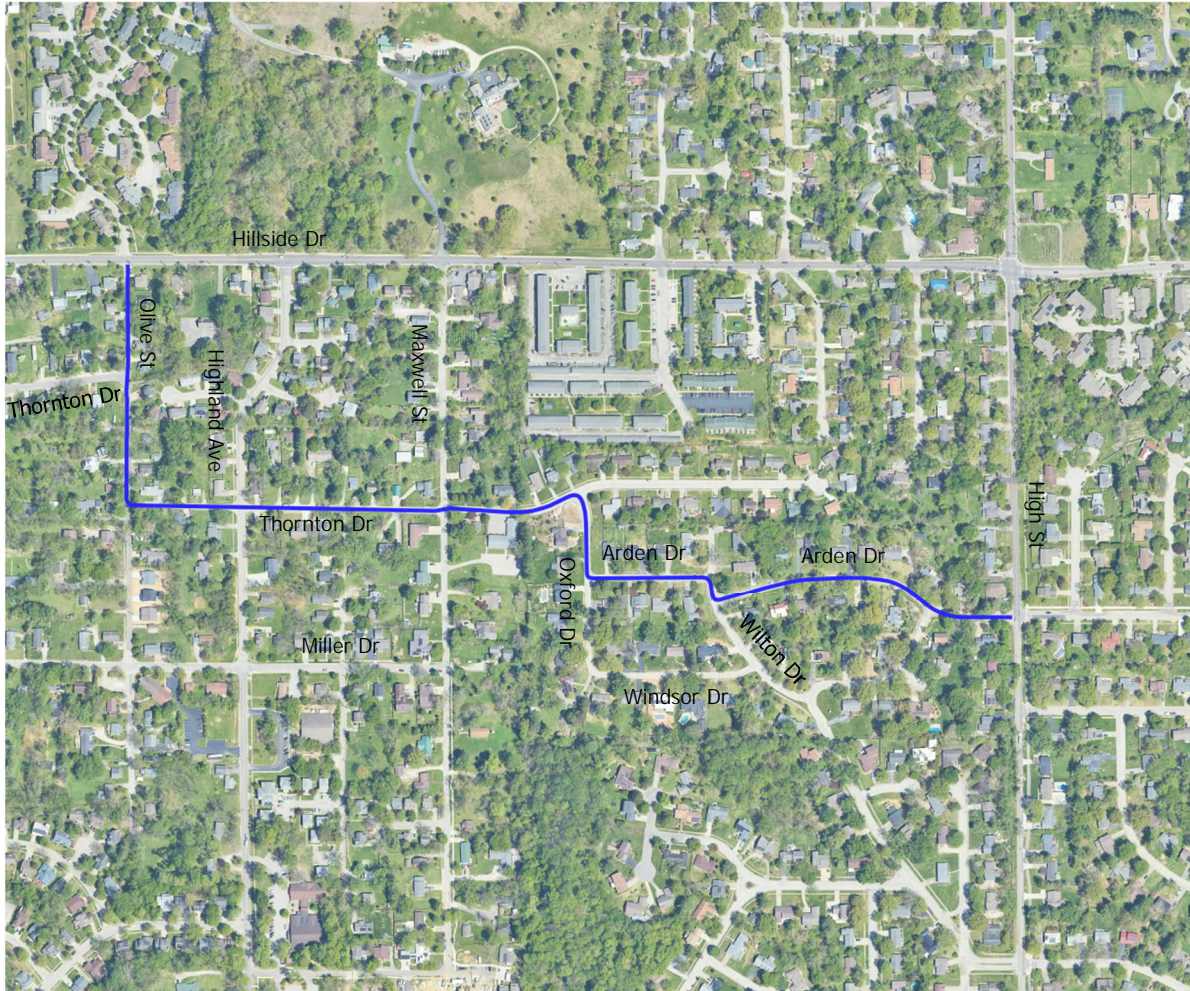

The project will include the addition of speed humps and speed cushions to Olive Street, Thornton Drive, Oxford Drive and Arden Drive, as well as signs and pavement markings to denote the route as a Neighborhood Greenway. The project will include upstream traffic calming along three cross-streets (Highland Avenue, Maxwell Street, and Wilton Drive). The project will also include the construction of new curb ramps on the east leg of the Thornton Drive and Oxford Drive intersection. The following intersection improvements are also included in the project:

- Thornton Drive & Olive Street – tighten the radius of the southwest corner
- Thornton Drive & Oxford Drive – tighten the radius of the southeast corner

WSP will be responsible for the following tasks as part of this Scope of Work:

Task 1. Project Management & Meetings

Through its Quality Management System (QMS), WSP has a recognized project management and quality control system with an established series of tracking templates. It is through the QMS that WSP manages its projects, facilitating the team's adherence to project scope, schedule, and budget. WSP's project manager will comply with the QMS procedures by preparing a project management plan and associated documents to guide the project. Monthly invoices will be prepared for submittal to the City of Bloomington.

Up to two (2) WSP representatives will attend up to three (3) meetings with the City during the design process.

Task 2. Design

As part of Task Order #1, WSP is preparing conceptual schematics of the proposed design. Based on the client and public feedback to the conceptual schematics, WSP will prepare the final design plans, specifications, and estimate (PS&E) package for bidding.

WSP will prepare a preliminary (95%) plan set for submittal and review. The preliminary submittal will include:

- Locations and typical details of curb ramps and speed cushions
- 95% level of detail for intersection improvements
- Maintenance of Traffic plans
- Signs and pavement markings
- Preliminary cost estimate
- QA/QC

During preliminary plan development, WSP will make a site visit to confirm design decisions. Up to two (2) WSP staff will attend.

After receipt of City of Bloomington comments on the preliminary plans, WSP will progress the plans to the Final Tracings (100%) submittal, considering review comments from the preliminary submittal during the final design phase. The Final Tracings submittal will include:

- Locations and typical details of curb ramps and speed cushions
- Intersection improvement designs
- Maintenance of Traffic plans
- Signs and pavement markings
- Opinion of probable construction cost
- Project specifications

Deliverables:

- Preliminary Submittal (95%)
- Final Tracings Submittal (100%)
- Electronic Design Files

Exclusions / Assumptions:

- No right-of-way acquisition will be required for this project.
- No topographic survey is going to be performed as part of this project.
- No detailed elevation data will be provided on design plans. Contractor to field verify design.
- City to provide recommended pavement treatment for radii modifications. Formal pavement design is excluded from this work.
- The anticipated area of disturbance is minor, with no permits expected to be required. Permitting is excluded from this scope of work.

- No environmental documentation is required or included in this scope of work.
- It is assumed that no legal drains, wetlands, jurisdictional waterways, or streams exist in the area of the trail connection.
- Hydraulic Analysis and Design are excluded from this scope of work.
- Tree mitigation and a tree mitigation plan are excluded from this scope of work.
- A right-of-entry will be needed for the construction of the tightened radius at the intersection of Thornton Drive & Olive Street and the construction of the new curb ramps east of and tighten the radius at the intersection of Thornton Drive & Oxford Drive. The City of Bloomington will prepare and execute right-of-entries.
- No public meetings are included in this scope of work.
- Signal design and corresponding geotechnical investigation is excluded from this scope of work.
- The City will compile the Contract Information Book and bid package. WSP will provide the plans, specifications, and estimate to be included in the bid package.

Task 3. Utility Coordination

WSP will perform utility coordination for the design and construction of the project.

Results / Deliverables:

- List of Affected Utilities in the Project Area
 - Perform an Indiana 811 Design Inquiry Ticket to obtain a list of member utilities and contacts in the project limits.
 - Send Initial Notice of Proposed Project to utilities
- Verify Utility Involvement & Utility Conflicts
 - Send Verification of Existing Facilities & Conflict Analysis Letters to utilities to determine extent of conflicts and practical solutions
 - Perform Conflict Analysis
 - Update CAD files with information provided by utilities
 - Coordinate with designers to mitigate utility conflicts
- Utility Work Plans
 - Send Utility Work Plan requests to utilities
 - Review Work Plans from utilities
 - Coordinate with designers on conflict solutions
 - Send Work Plan Approval letters to utilities
- Utility Certification & Utility Special Provisions
 - Prepare a Utility Special Provision similar to INDOT 107-R-169

Exclusions / Assumptions:

- It is assumed that no relocations will be part of this project.
- Existing City of Bloomington Utilities information within the project limits will be provided by the City of Bloomington.
- It is assumed that there are no more than eight (8) utilities in the project area.
- The Consultant has no control over utility companies' level of effort or schedules. The City of Bloomington will be available for advice and will be available in matters where Bloomington's authority is needed, such as signing of official documents.
- The Consultant will review relocation plans and schedules to verify that all conflicts are resolved.
- Detailed design and layout of affected utilities is excluded from this scope of work.
- Subsurface Utility Engineering is excluded from this scope of work.
- Reimbursable agreements are excluded from this scope of work.
- A digital CAD file showing master utility relocations or as-builts is excluded from this scope of work.

Task 4. Post-Design Services

WSP will provide up to 16 hours of post-design engineering services, which could include:

- Attending the Pre-Construction Meeting (up to 2 attendees)
- Responding to RFI's
- Review of Shop Drawings

WSP will provide up to 8 hours of post-design utility coordination services, which could include:

- Attending the Pre-Construction Meeting (up to 1 attendee)
- Coordinating between the Utilities, Contractor, and City of Bloomington
- Answering Contractor questions

Deliverables:

- RFI Responses
- Shop Drawing Reviews

Exclusions / Assumptions:

- Construction Engineering is not included.
- Inspection services are not included.
- The approval of the shop drawings does not indicate Consultant's approval of Contractor's means and methods, technique, sequence or safety precautions and procedures.
- It is assumed that the City of Bloomington is responsible for the bidding process.

Exhibit 2A - Rate Schedule
Thornton and Arden Designs

P-Grade	Classification	Hourly Rate	Contract Rate
P-07	ASSISTANT CONSULTANT, CIVIL ENGINEER	\$ 35.38	\$ 95.01
P-07	ASSISTANT CONSULTANT, ENVIRONMENTAL ENGINEER	\$ 33.66	\$ 90.39
P-07	ASSISTANT CONSULTANT, STRUCTURAL ENGINEER	\$ 40.06	\$ 107.59
P-07	ASSISTANT CONSULTANT, TRAFFIC ENGINEER	\$ 36.04	\$ 96.79
P-07	ASSISTANT CONSULTANT, TRANSPORTATION PLANNER	\$ 36.07	\$ 96.87
P-07	ASSISTANT CONSULTANT, WATER RESOURCES ENGINEER	\$ 37.96	\$ 101.93
P-08	ASSOCIATE CONSULTANT, CIVIL ENGINEER	\$ 67.09	\$ 180.17
X-08	ASSOCIATE CONSULTANT, PROJECT ACCOUNTING	\$ 39.17	\$ 105.19
P-08	ASSOCIATE CONSULTANT, STRUCTURAL ENGINEER	\$ 44.52	\$ 119.56
P-08	ASSOCIATE CONSULTANT, TRAFFIC ENGINEER	\$ 44.16	\$ 118.58
P-08	ASSOCIATE CONSULTANT, TRANSPORTATION PLANNER	\$ 43.79	\$ 117.59
P-08	ASSOCIATE CONSULTANT, WATER RESOURCES ENGINEER	\$111.45	\$ 299.27
P-09	CONSULTANT, ACCOUNTING	\$ 46.62	\$ 125.19
P-09	CONSULTANT, CIVIL ENGINEER	\$ 50.32	\$ 135.13
P-09	CONSULTANT, ENVIRONMENTAL ENGINEER	\$ 48.68	\$ 130.72
P-09	CONSULTANT, GRAPHIC DESIGN	\$ 45.69	\$ 122.69
P-09	CONSULTANT, LAND/URBAN PLANNER	\$ 46.17	\$ 123.97
X-09	CONSULTANT, PROJECT ACCOUNTING	\$ 45.28	\$ 121.59
P-09	CONSULTANT, STRUCTURAL ENGINEER	\$ 52.18	\$ 140.11
P-09	CONSULTANT, TRAFFIC ENGINEER	\$ 51.09	\$ 137.19
P-09	CONSULTANT, TRANSPORTATION PLANNER	\$ 48.36	\$ 129.87
P-09	CONSULTANT, WATER RESOURCES ENGINEER	\$ 49.91	\$ 134.03
X-12	ASSISTANT VICE PRESIDENT, ACCOUNTING	\$ 91.61	\$ 246.01
P-12	ASSISTANT VICE PRESIDENT, CIVIL ENGINEER	\$ 88.09	\$ 236.55
P-12	ASSISTANT VICE PRESIDENT, CONTRACT MANAGEMENT	\$ 71.17	\$ 191.12
X-12	ASSISTANT VICE PRESIDENT, CONTRACTS	\$ 77.00	\$ 206.76
P-12	ASSISTANT VICE PRESIDENT, ENVIRONMENTAL PLANNER	\$ 77.77	\$ 208.84
P-12	ASSISTANT VICE PRESIDENT, GEOTECHNICAL ENGINEER	\$ 97.52	\$ 261.86
P-12	ASSISTANT VICE PRESIDENT, LAND/URBAN PLANNER	\$ 72.23	\$ 193.96
X-12	ASSISTANT VICE PRESIDENT, PROJECT ACCOUNTING	\$ 73.03	\$ 196.12
P-12	ASSISTANT VICE PRESIDENT, STRUCTURAL ENGINEER	\$ 84.12	\$ 225.90
P-12	ASSISTANT VICE PRESIDENT, TRAFFIC ENGINEER	\$ 83.99	\$ 225.53
P-12	ASSISTANT VICE PRESIDENT, TRANSPORTATION PLANNER	\$ 75.77	\$ 203.46
P-12	ASSISTANT VICE PRESIDENT, WATER RESOURCES ENGINEER	\$ 81.89	\$ 219.92
T-05	INTERN, CIVIL ENGINEERING	\$ 23.43	\$ 62.91
T-05	INTERN, TRAFFIC ENGINEERING	\$ 24.61	\$ 66.09
P-11	LEAD CONSULTANT, CIVIL ENGINEER	\$ 73.97	\$ 198.63
P-11	LEAD CONSULTANT, CONTRACT MANAGEMENT	\$ 69.75	\$ 187.30
P-11	LEAD CONSULTANT, DOCUMENT CONTROL	\$ 72.78	\$ 195.44
P-11	LEAD CONSULTANT, ENVIRONMENTAL ENGINEER	\$ 56.88	\$ 152.74
P-11	LEAD CONSULTANT, LAND/URBAN PLANNER	\$ 60.79	\$ 163.24
P-11	LEAD CONSULTANT, STRUCTURAL ENGINEER	\$ 71.94	\$ 193.17
P-11	LEAD CONSULTANT, TRAFFIC ENGINEER	\$ 66.98	\$ 179.86
P-11	LEAD CONSULTANT, TRANSPORTATION PLANNER	\$ 60.60	\$ 162.73
P-11	LEAD CONSULTANT, WATER RESOURCES ENGINEER	\$ 70.87	\$ 190.30
T-10	LEAD TECHNICAL ENGINEERING SUPPORT SPECIALIST	\$ 63.76	\$ 171.23
X-11	MANAGER, CONTRACTS	\$ 62.99	\$ 169.15
X-11	MANAGER, PROJECT ACCOUNTING	\$ 63.07	\$ 169.35
P-14	SENIOR VICE PRESIDENT I, CIVIL ENGINEER	\$131.40	\$ 352.86
X-14	SENIOR VICE PRESIDENT I, CONTRACTS	\$141.66	\$ 380.41
X-14	SENIOR VICE PRESIDENT I, DISTRICT BUSINESS LINE	\$137.94	\$ 370.41
X-14	SENIOR VICE PRESIDENT I, LOCAL BUSINESS LEADER	\$129.56	\$ 347.90
P-14	SENIOR VICE PRESIDENT I, STRUCTURAL ENGINEER	\$127.83	\$ 343.27
X-14	SENIOR VICE PRESIDENT I, TRAFFIC ENGINEER	\$114.65	\$ 307.88
X-10	SR. CONSULTANT, ACCOUNTING	\$ 40.13	\$ 107.76
P-10	SR. CONSULTANT, CIVIL ENGINEER	\$ 57.14	\$ 153.45
X-10	SR. CONSULTANT, CONTRACTS	\$ 47.74	\$ 128.19
X-10	SR. CONSULTANT, PROJECT ACCOUNTING	\$ 54.05	\$ 145.13
P-10	SR. CONSULTANT, STRUCTURAL ENGINEER	\$ 60.47	\$ 162.39
P-10	SR. CONSULTANT, TRAFFIC ENGINEER	\$ 57.08	\$ 153.28
P-10	SR. CONSULTANT, WATER RESOURCES ENGINEER	\$ 58.87	\$ 158.09
P-13	VICE PRESIDENT, CIVIL ENGINEER	\$102.83	\$ 276.13
P-13	VICE PRESIDENT, CONTRACTS	\$104.97	\$ 281.87
X-13	VICE PRESIDENT, DISTRICT BUSINESS LINE	\$102.01	\$ 273.93
P-13	VICE PRESIDENT, ENVIRONMENTAL ENGINEER	\$ 78.14	\$ 209.83
X-13	VICE PRESIDENT, LOCAL BUSINESS LEADER	\$100.63	\$ 270.22
X-13	VICE PRESIDENT, PROJECT ACCOUNTING	\$ 86.38	\$ 231.96
P-13	VICE PRESIDENT, STRUCTURAL ENGINEER	\$101.74	\$ 273.20
P-13	VICE PRESIDENT, TRAFFIC ENGINEER	\$ 95.52	\$ 256.52
P-13	VICE PRESIDENT, WATER RESOURCES ENGINEER	\$101.30	\$ 272.03
X-12	SR. LEAD CONSULTANT, STRUCTURAL ENGINEER	\$ 74.27	\$ 191.22
X-12	SR. LEAD CONSULTANT, TRAFFIC ENGINEER	\$ 68.51	\$ 176.41
X-12	SR. LEAD CONSULTANT, WATER RESOURCES ENGINEER	\$ 61.34	\$ 157.94
T-11	SR. MANAGER, ACCOUNTING	\$ 63.24	\$ 162.83
X-12	SR. MANAGER, CONTRACTS	\$ 73.15	\$ 188.35
X-12	SR. MANAGER, PROJECT ACCOUNTING	\$ 60.23	\$ 155.07



Bloomington Neighborhood Greenways

WSP PROJECT NO.: 30900699

DES. NO.: TBD

DESCRIPTION: Task 3 - Thornton & Arden Designs

Client: City of Bloomington

			Proposed Fees	
TASKS	Description	Contract Type	WSP USA	Subtotal
Section 1	Project Management	Negotiated Labor Rate	\$5,709	\$5,709
Section 2	Design	Negotiated Labor Rate	\$30,121	\$30,121
Section 3	Utility Coordination	Negotiated Labor Rate	\$4,101	\$4,101
Section 4	Post Design Services	Negotiated Labor Rate	\$5,044	\$5,044
Subtotal			\$44,975	\$44,975

GRAND TOTAL \$44,975



Project Management

PROJECT NO.: 30900699

DES. NO.: TBD

DESCRIPTION: Task 3 - Thornton & Arden Designs

DESCRIPTION	PERSON HOURS BY CLASSIFICATION													TOTAL HOURS / TASK	TOTAL DOLLARS / TASK		
	X-14	X-14	X-13	P-12	X-11	P-11	P-09	P-08	P-07	X-10	T-11	T-10	T-06				
	SENIOR VICE PRESIDENT I, LOCAL BUSINESS LEADER	SENIOR VICE PRESIDENT I, CIVIL ENGINEER	VICE PRESIDENT, CIVIL ENGINEER	ASSISTANT VICE PRESIDENT, CIVIL ENGINEER	LEAD CONSULTANT, CIVIL ENGINEER	LEAD CONSULTANT, TRAFFIC ENGINEER	CONSULTANT, CIVIL ENGINEER	ASSOCIATE CONSULTANT, CIVIL ENGINEER	ASSISTANT CONSULTANT, CIVIL ENGINEER	SR. CONSULTANT, PROJECT ACCOUNTING	SR. LEAD TECHNICIAN	LEAD TECHNICIAN	SR. INTERN				
Overhead Classification	GSO	GSO	GSO	GSO	GSO	GSO	GSO	GSO	GSO	GSO	GSO	GSO					
Project Setup & Ongoing Management	1.00			8.00						6.00						15.00	\$3,111.11
Client Meetings (Up to 3)				6.00		6.00										12.00	\$2,498.47
SUBTOTAL:													27	\$5,610.00			
TOTAL - HOURS:	1.00	0.00	0.00	14.00	0.00	6.00	0.00	0.00	0.00	6.00	0.00	0.00	0.00			27	
SALARY PER HOUR	\$347.90	\$352.86	\$276.13	\$236.55	\$198.63	\$179.86	\$135.13	\$180.17	\$95.01	\$145.13	\$242.84	\$151.11	\$0.00				
DIRECT SALARY COSTS:	\$347.90	\$0.00	\$0.00	\$3,311.72	\$0.00	\$1,079.16	\$0.00	\$0.00	\$0.00	\$870.79	\$0.00	\$0.00	\$0.00				\$5,610.00
DIRECT EXPENSES																	
Mileage	1.00				Trips x	120	Mi./Trip x	\$0.490									\$58.80
Meals	2.00				Persons x	1.00	Days x	20									\$40.00
																	\$0.00
DIRECT EXPENSES:																	\$99.00
TOTAL COSTS (Direct Labor Costs + Expenses):																	\$5,709.00



Design

PROJECT NO.: 30900699

DES. NO.: TBD

DESCRIPTION: Task 3 - Thornton & Arden Designs

DESCRIPTION	PERSON HOURS BY CLASSIFICATION													TOTAL HOURS / TASK	TOTAL DOLLARS / TASK		
	X-14	X-14	X-13	X-12	X-11	P-10	P-10	P-09	P-09	X-10	T-11	T-10	T-06				
	SENIOR VICE PRESIDENT I, LOCAL BUSINESS LEADER	SENIOR VICE PRESIDENT I, CIVIL ENGINEER	VICE PRESIDENT, CIVIL ENGINEER	ASSISTANT VICE PRESIDENT, CIVIL ENGINEER	LEAD CONSULTANT, CIVIL ENGINEER	SR. CONSULTANT, CIVIL ENGINEER	CONSULTANT, CIVIL ENGINEER	ASSOCIATE CONSULTANT, CIVIL ENGINEER	ASSISTANT CONSULTANT, CIVIL ENGINEER	SR. CONSULTANT, PROJECT ACCOUNTING	SR. LEAD TECHNICIAN	LEAD TECHNICAL ENGINEERING SUPPORT SPECIALIST	SR. INTERN				
Overhead Classification	GSO	GSO	GSO	GSO	GSO	GSO	GSO	GSO	GSO	GSO	GSO	GSO					
Preliminary Plan Submittal (95%)																	
Initial Field Visit				6.00					6.00							12.00	\$1,989.36
Title Sheet									2.00							2.00	\$190.02
Index Sheet									1.00							1.00	\$95.01
Strip Map - Thornton									8.00							8.00	\$760.07
Strip Map - Arden									8.00							8.00	\$760.07
Typical Details (Bump Outs and Speed Cushions)				2.00					8.00							10.00	\$1,233.17
Intersection Detail Sheet - Thornton & Olive				2.00					8.00							10.00	\$1,233.17
Curb Ramp Details - Thornton & Oxford				4.00					12.00							16.00	\$2,086.31
Erosion Control Plans									4.00							4.00	\$380.03
MOT Plans				2.00					16.00							18.00	\$1,993.24
Pavement Marking & Sign Sheets				10.00				10.00								20.00	\$4,167.21
Pavement Marking & Sign Summary Tables				2.00				6.00								8.00	\$1,554.12
Preliminary Quantities & Cost Estimate									16.00							16.00	\$1,520.13
QA/QC of Deliverables				12.00					2.00							14.00	\$3,028.64
Final Plan Submittal (100%)																	
Revise Plans per Comments				2.00					8.00							10.00	\$1,233.17
Finalize Intersection Detail Sheets				1.00					4.00							5.00	\$616.59
Finalize Curb Ramp Details				1.00					4.00							5.00	\$616.59
Finalize MOT Plans				1.00					2.00							3.00	\$426.57
Finalize Pavement Marking & Sign Sheets				2.00				2.00								4.00	\$833.44
Miscellaneous Summary Tables									2.00							2.00	\$190.02
Roadway Design Calcs									4.00							4.00	\$380.03
Prepare Special Provisions				4.00												4.00	\$946.21
Final Quantities & Cost Estimate				4.00					8.00							12.00	\$1,706.27
QA/QC of Deliverables				8.00					2.00							10.00	\$2,082.43
SUBTOTAL:																206	\$30,022.00
TOTAL - HOURS:	0.00	0.00	0.00	63.00	0.00	0.00	0.00	18.00	125.00	0.00	0.00	0.00	0.00			206	
SALARY PER HOUR	\$347.90	\$352.86	\$276.13	\$236.55	\$198.63	\$153.45	\$135.13	\$180.17	\$95.01	\$145.13	\$242.84	\$171.23	\$0.00				
DIRECT SALARY COSTS:	\$0.00	\$0.00	\$0.00	\$14,902.76	\$0.00	\$0.00	\$0.00	\$3,243.04	\$11,876.04	\$0.00	\$0.00	\$0.00	\$0.00				\$30,022.00
DIRECT EXPENSES																	
Mileage	1.00				Trips x	120	Mi./Trip x	\$0.490									\$58.80
Meals	2.00				Persons x	1.00	Days x	20									\$40.00
DIRECT EXPENSES:																	\$99.00
TOTAL COSTS (Direct Labor Costs + Expenses):																	\$30,121.00



Utility Coordination

PROJECT NO.: 30900699

DES. NO.: TBD

DESCRIPTION: Task 3 - Thornton & Arden Designs

DESCRIPTION	PERSON HOURS BY CLASSIFICATION												TOTAL HOURS / TASK	TOTAL DOLLARS / TASK	
	X-14	X-14	X-13	X-12	X-11	P-10	P-09	P-08	P-07	X-10	T-11	T-10			T-06
	SENIOR VICE PRESIDENT I, LOCAL BUSINESS LEADER	SENIOR VICE PRESIDENT I, CIVIL ENGINEER	VICE PRESIDENT, CIVIL ENGINEER	ASSISTANT VICE PRESIDENT, CIVIL ENGINEER	LEAD CONSULTANT, CIVIL ENGINEER	SR. CONSULTANT, CIVIL ENGINEER	CONSULTANT, CIVIL ENGINEER	ASSOCIATE CONSULTANT, CIVIL ENGINEER	ASSISTANT CONSULTANT, CIVIL ENGINEER	SR. CONSULTANT, PROJECT ACCOUNTING	SR. LEAD TECHNICIAN	LEAD TECHNICAL ENGINEERING SUPPORT SPECIALIST			SR. INTERN
Overhead Classification	GSO	GSO	GSO	GSO	GSO	GSO	GSO	GSO	GSO	GSO	GSO	GSO			
<i>General IAC Requirements</i>															
Identify Utility Stakeholders				2.00										2.00	\$473.10
Prepare & Distribute "Initial Notice" & "Verification of Facilities" Letter				2.00										2.00	\$473.10
<i>Project Utility Meetings</i>															
Research Facilities in Project Corridor				2.00										2.00	\$473.10
Internal Kick-off Meeting				1.00										1.00	\$236.55
<i>Utility/Design Integration</i>															
Develop & Maintain Utility Coordination Log				1.00										1.00	\$236.55
Coordinate Color Coded Plan Set for Utilities				2.00										2.00	\$473.10
Develop Utility Special Provisions for Contract Book				2.00										2.00	\$473.10
Status Updates (Internal & External)				1.00										1.00	\$236.55
Design Coordination Meetings				2.00										2.00	\$473.10
<i>Work Plan Development & Review</i>															
Coordinate & Assist with Utility Work Plan Development				2.00										2.00	\$473.10
SUBTOTAL:														17	\$4,022.00
TOTAL - HOURS:	0.00	0.00	0.00	17.00	0.00	0.00	0.00	0.00	0.00	0.00	0.00	0.00	0.00	17	
SALARY PER HOUR	\$347.90	\$352.86	\$276.13	\$236.55	\$198.63	\$153.45	\$135.13	\$180.17	\$95.01	\$145.13	\$242.84	\$171.23	\$0.00		
DIRECT SALARY COSTS:	\$0.00	\$0.00	\$0.00	\$4,021.38	\$0.00	\$0.00	\$0.00	\$0.00	\$0.00	\$0.00	\$0.00	\$0.00	\$0.00		\$4,022.00
DIRECT EXPENSES															
Mileage	1.00				Trips x	120	Mi./Trip x	\$0.490							\$58.80
Meals	1.00				Persons x	1.00	Days x	20							\$20.00
DIRECT EXPENSES:															\$79.00
TOTAL COSTS (Direct Labor Costs + Expenses):															\$4,101.00



Post Design Services

PROJECT NO.: 30900699

DES. NO.: TBD

DESCRIPTION: Task 3 - Thornton & Arden Designs

DESCRIPTION	PERSON HOURS BY CLASSIFICATION													TOTAL HOURS / TASK	TOTAL DOLLARS / TASK	
	X-14	X-14	X-13	X-12	X-11	P-10	P-09	P-08	P-07	X-10	T-11	T-10	T-06			
	SENIOR VICE PRESIDENT I, LOCAL BUSINESS LEADER	SENIOR VICE PRESIDENT I, CIVIL ENGINEER	VICE PRESIDENT, CIVIL ENGINEER	ASSISTANT VICE PRESIDENT, CIVIL ENGINEER	LEAD CONSULTANT, CIVIL ENGINEER	SR. CONSULTANT, CIVIL ENGINEER	CONSULTANT, CIVIL ENGINEER	ASSOCIATE CONSULTANT, CIVIL ENGINEER	ASSISTANT CONSULTANT, CIVIL ENGINEER	SR. CONSULTANT, PROJECT ACCOUNTING	SR. LEAD TECHNICIAN	LEAD TECHNICAL ENGINEERING SUPPORT SPECIALIST	SR. INTERN			
Overhead Classification	GSO	GSO	GSO	GSO	GSO	GSO	GSO	GSO	GSO	GSO	GSO	GSO				
<i>Engineering Services</i>																
Attend Pre-Construction Meeting				4.00			4.00								8.00	\$1,486.73
Respond to Requests for Information				2.00			2.00								4.00	\$743.36
Review Shop Drawings				2.00			2.00								4.00	\$743.36
<i>Utility Services</i>																
Attend Pre-Construction Meeting				4.00											4.00	\$946.21
Coordinate between Utility, Contractor, & Client				2.00											2.00	\$473.10
Answer Contractor Questions				2.00											2.00	\$473.10
SUBTOTAL:														24	\$4,866.00	
TOTAL - HOURS:	0.00	0.00	0.00	16.00	0.00	0.00	8.00	0.00	0.00	0.00	0.00	0.00	0.00	0.00	24	
SALARY PER HOUR	\$347.90	\$352.86	\$276.13	\$236.55	\$198.63	\$153.45	\$135.13	\$180.17	\$95.01	\$145.13	\$242.84	\$171.23	\$0.00			
DIRECT SALARY COSTS:	\$0.00	\$0.00	\$0.00	\$3,784.83	\$0.00	\$0.00	\$1,081.05	\$0.00	\$0.00	\$0.00	\$0.00	\$0.00	\$0.00			\$4,866.00
DIRECT EXPENSES																
Mileage	2.00				Trips x	120	Mi./Trip x	\$0.490								\$117.60
Meals	3.00				Persons x	1.00	Days x	20								\$60.00
DIRECT EXPENSES:															\$178.00	
TOTAL COSTS (Direct Labor Costs + Expenses):																\$5,044.00

EXHIBIT 3 - SCHEDULE
Thornton Drive to Arden Drive Designs

Preliminary Plan Submittal	September 27, 2024
Final Tracings Submittal	October 14, 2024



Board of Public Works Staff Report

Project/Event: Strauser Construction Request for Sidewalk Closure
Staff Representative: Dashiell Schonemann-Poppeliers
Petitioner/Representative: Ryan Strauser
Date: September 10th, 2024

Report: Strauser Construction is requesting a road closure on N Grant St between E 9th and E 10th St in addition to the closure of the western sidewalk. The closure is requested to begin late September and finish late October. This request is to accommodate utility extension for a new building project at 527 N Grant St. Strauser Construction has supplied a maintenance of traffic plan for the closures.

August 14, 2024

City of Bloomington - Board of Public Works

401 N. Morton Street
Bloomington, IN 47404

RE: 527 N. Grant - Apartments
527 N. Grant Street
Bloomington, Indiana
ROW Use Request

Dear Board Members:

Strauser Construction Co., Inc. is the construction manager for a new building being constructed at 527 N. Grant Street. As part of the project, we will need to extend utilities into Grant Street for connection to City mains and re-construct sections of asphalt and sidewalks as part of this process.

Strauser Construction Co., Inc. is requesting the use of the right of way for completion of this work. Currently we are asking for a closure of the west sidewalk and Grant Street for a period of September 30, 2024 through October 20, 2024. This closure would be between 9th Street & 10th Street, while still providing local access for properties in this block during construction activities.

Additionally, our plan is that a full street closure will not be needed for the entire duration. We would plan to begin with utility connections to the middle of the street and once complete with that work, re-open the traffic lanes as soon as possible within the timeframe. In doing this we would still have some paving and concrete sidewalk work in the ROW until the end of the requested time. But this should be able to be completed with the sidewalk closures and flaggers as needed.

During the course of this project Strauser Construction Co., Inc. will work with the City of Bloomington and City of Bloomington Engineering to minimize disruptions caused by the project. Based on the attached information, Strauser Construction Co., Inc. request that the Board of Public Works approves the use of the right of way during the time periods stated above.

Sincerely,

Ryan M. Strauser

Ryan M. Strauser
RA, AIA, LEED AP

Strauser Construction Co., Inc.
453 S. Clarizz Blvd.
Bloomington, IN 47401

PERMIT SET ONLY

ARCHITECTURE
CIVIL ENGINEERING
PLANNING

BBB
BYNUM FANYO & ASSOCIATES, INC.

528 north walnut street
(812) 332-8030

bloomington, indiana
(812) 339-2990 (Fax)

certified by *[Signature]*

PROPOSED
527 N GRANT APARTMENTS

527 NORTH GRANT STREET
BLOOMINGTON, IN 47403

title: SITE PLAN

designed by: JBT
drawn by: JBT
checked by: JBT
sheet no: C301
project no.: 402351

EXISTING LEGEND

---	PROPERTY LINE
X	FENCE
XW	WATER LINE PIPE
XXX	CONTOUR & ELEVATION
XSS	SANITARY SEWER PIPE
XST	STORM SEWER PIPE
XOHE	OVERHEAD ELECTRIC LINES
XUGE	UNDERGROUND ELECTRIC LINES
XOHT	OVERHEAD TELEPHONE LINES
XUGT	UNDERGROUND TELEPHONE LINE
XGAS	GAS LINE PIPE

SITE LEGEND

A	ASPHALT PAVEMENT
AP	ADA ACCESSIBLE PARKING SPACE, 39" INTERNATIONAL ADA SYMBOL, STRIPING, AISLES, SIGNAGE AND SLOPES SHALL CONFORM WITH THE MOST STRINGENT OF FEDERAL, STATE AND LOCAL ACCESSIBLE GUIDELINES.
BP	BIKE PARKING FACILITIES ON CONCRETE PAD
C	6-IN DEPTH CONCRETE PAVEMENT
CL	CONSTRUCTION LIMITS
F	CONCRETE SIDEWALK
FI	MONOLITHIC CONCRETE CURB & SIDEWALK
L	LAWN OR LANDSCAPE AREA - SEE C501
M	MATCH EXISTING CURB, SIDEWALK, PAVEMENT ELEVATIONS
PP	PAVEMENT PATCH
R1	ADA ACCESSIBLE SIDEWALK RAMP WITH HANDRAIL ON EACH SIDE
R2	ADA ACCESSIBLE CURB RAMP WITHOUT DETECTABLE WARNINGS
RW	RETAINING WALL W/ GUARDRAIL AS REQUIRED FOR HEIGHTS OF 2.5 FT OR GREATER. SEE COMPLETE DESIGN BY OTHERS.
13	CONCRETE CURB, 6" WIDE

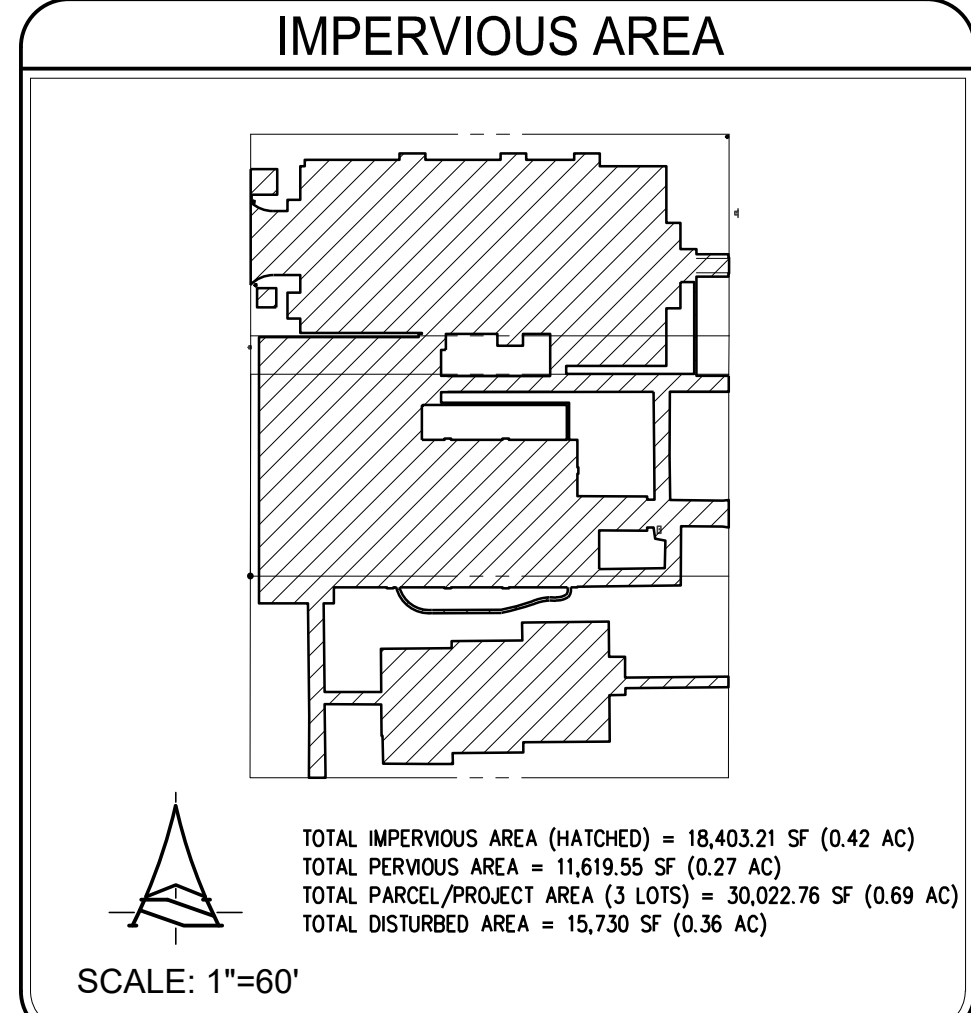

NOTE TO CONTRACTOR

CONTRACTOR SHALL VERIFY ALL UTILITY LOCATIONS & DEPTHS AND NOTIFY ENGINEER OF ANY INACCURACIES IN LOCATION OR ELEVATION OR ANY CONFLICTS PRIOR TO & AFTER ANY EXCAVATION. NO PAYMENT SHALL BE MADE TO CONTRACTOR FOR UTILITY DESTRUCTION OR UNDERGROUND CHANGES REQUIRED DUE TO CONFLICTING ELEVATIONS.

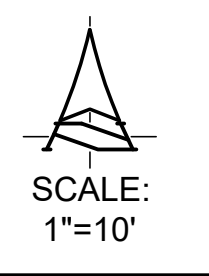
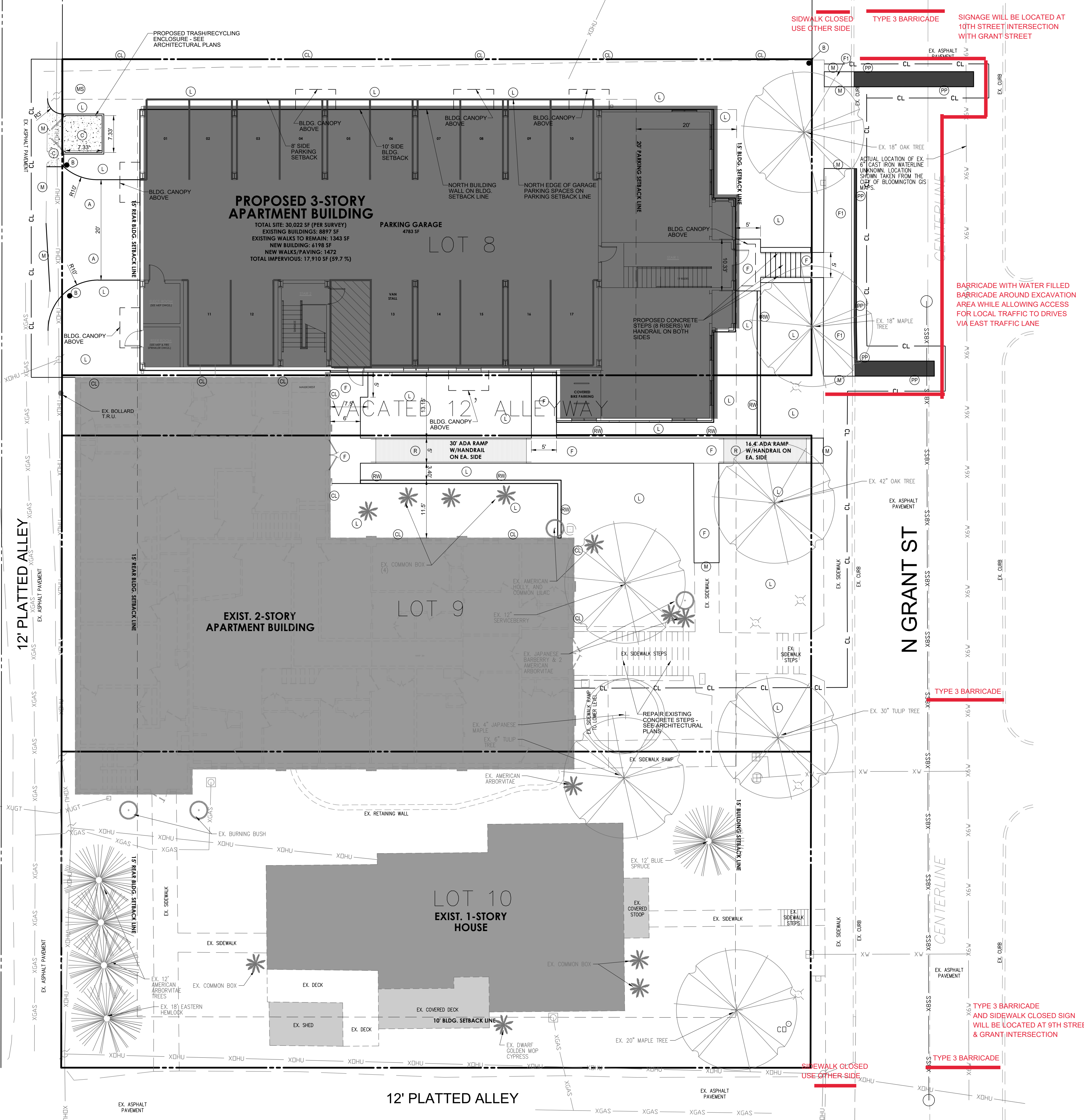



Board of Public Works Staff Report

Project/Event: Road Closures in Near West Side Neighborhood
Staff Representative: Dashiell Schonemann-Poppeliers
Petitioner/Representative: Chaz Mottinger
Date: September 10th, 2024

Report: The City of Bloomington Department of Economic & Sustainable Development is requesting five road closures at traffic calming circles located in the Near West Side Neighborhood. The closures include the intersections of W 6th St and N Waldron St, W 6th St and N Oak St, W 7th St and N Oak St, W 7th St and N Waldron St, W 7th and N Pine St. Each closure is expected to last 3-5 days for a total duration of 5 weeks beginning on 9/16/24 and ending on 10/28/24. This request is to accommodate the painting of mural designs on the five traffic calming circles by artist Erin Tobey. Maintenance of traffic plans have been supplied for the closures.

**AGREEMENT
BETWEEN
THE CITY OF BLOOMINGTON
AND
ERIN TOBEY
FOR
NEAR WESTSIDE NEIGHBORHOOD MURAL**

This Agreement, entered into on this 4_____ day of June, 2024, by and between the City of Bloomington Art Commission, the Economic & Sustainable Development Department, and the Housing and Neighborhood Development Department (the “City”), and Erin Tobey (“Artist”),

WITNESSETH:

WHEREAS, the Department wishes to paint approved mural designs on five traffic calming circles located in the Near West Side of Bloomington, Indiana; and

WHEREAS, the Department requires the services of a professional artist in order to paint the murals (the “Services” as further defined below); and

WHEREAS, it is in the public interest that such Services be undertaken and performed; and

WHEREAS, Artist is willing and able to provide such Services to the Department.

NOW, THEREFORE, in consideration of the mutual covenants herein contained, the parties hereto agree as follows:

Article 1. Scope of Services

Artist shall provide the Services as specified in Exhibit A, “Scope of Work”, attached hereto and incorporated into this Agreement. Artist acknowledges that all Services and work under this Agreement will comply with the City of Bloomington Policy and Procedures on Private Art Installation within the Public Right of Way, which is attached to this Agreement as Exhibit B, and the City’s Neighborhood Improvement Grant Program.

Artist shall diligently provide the Services under this Agreement and shall complete the Services described in this Agreement in a timely manner consistent with the Standard of Care identified in Article 2.

Artist shall complete the Services required under this Agreement on or before January 1, 2025, unless the parties mutually agree to a later completion date. Completion shall mean completion of all work related to the Services.

In the performance of Artist’s work, Artist agrees to maintain such coordination with the City as may be requested and desirable, including primary coordination with Holly Warren, Assistant Director for the Arts, as the City’s Project Manager. Artist agrees that any information or documents, including digital GIS information, supplied by the City pursuant to Article 3, below, shall be used by Artist for this project only, and shall not be reused or reassigned for any other purpose without the

written permission of the City. Artist agrees that the Services are provided in accordance with the City of Bloomington Policy and Procedures on Private Art Installations within the Public Right of Way.

Article 2. Standard of Care

Artist shall be responsible for completion of the Services in a manner consistent with that degree of care and skill ordinarily exercised by members of the same profession currently practicing under similar circumstances (“Standard of Care”). The City shall be the sole judge of the adequacy of Artist’s work in meeting the Standard of Care; however, the City shall not unreasonably withhold its approval as to the adequacy of Artist’s performance. Upon notice to Artist and by mutual agreement between the parties, Artist will, without additional compensation, correct or replace any and all Services not meeting the Standard of Care.

Article 3. Responsibilities of the City

The City shall provide all necessary information regarding requirements for the Services. The City shall furnish such information as expeditiously as is necessary for the orderly progress of the work, and Artist shall be entitled to rely upon the accuracy and completeness of such information. The City’s Project Manager shall act on its behalf with respect to this Agreement. The City shall review and approve any and all designs of art placed in the right-of-way in compliance with the City of Bloomington Policy and Procedures on Private Art Installations within the Public Right of Way.

Article 4. Compensation

The City shall pay Artist for all fees and expenses in an amount not to exceed **Five Thousand One Hundred Eighty Dollars (\$5,180.00)**. Invoices may be sent via first class mail postage prepaid or via email. Payment will be remitted to Artist within forty-five (45) days of receipt of invoice. Artist shall submit an invoice to the City upon the completion of the Services described in Article 1. The invoice shall be sent to:

Holly Warren
City of Bloomington
401 N. Morton, Suite 150
Bloomington, Indiana 47404

Additional services not set forth in Article 1, or changes in the Services must be authorized in writing by the City or its designated project coordinator prior to such work being performed, or expenses incurred. The City shall not make payment for any unauthorized work or expenses.

Article 5. Appropriation of Funds

Notwithstanding any other provision of this Agreement, if funds for the continued fulfillment of this Agreement by the City are at any time not forthcoming or are insufficient, through failure of any entity, including the City itself, to appropriate funds or otherwise, then the City shall have the right to terminate this Agreement without penalty.

Article 6. Schedule

Artist shall complete the Services required under this Agreement on or before **January 1, 2025**. The time limits established by this schedule shall not be exceeded, except for reasonable cause as mutually agreed by the parties.

Article 7. Termination

In the event of a party's substantial failure to perform in accordance with the terms of this Agreement, the other party shall have the right to terminate the Agreement upon written notice. The nonperforming party shall have fourteen (14) calendar days from the receipt of the termination notice to cure or to submit a plan for cure acceptable to the other party.

The City may terminate or suspend performance of this Agreement at the City's prerogative at any time upon written notice to Artist. Artist shall terminate or suspend performance of the Services on a schedule acceptable to the City and the City shall pay the Artist for all the Services performed up to the date that written notice is received, plus reasonable termination or suspension expenses. Upon restart, an equitable adjustment shall be made to Artist's compensation and the schedule of services. Upon termination or suspension of this Agreement, all finished or unfinished reports, drawings, collections of data and other documents generated by Artist in connection with this Agreement shall become the property of the City, as set forth in Article 10 herein.

Article 8. Identity of the Artist

Artist acknowledges that one of the primary reasons for its selection by the City to perform the Services is the qualifications and experience of Artist, Erin Tobey. Artist thus agrees that the Services to be performed pursuant to this Agreement shall be performed by Erin Tobey. Artist shall not subcontract any part of the Services without the prior written permission of the City. The City reserves the right to reject any of the Artist's personnel or proposed outside professional sub-Artists, and the City reserves the right to request that acceptable replacement personnel be assigned to the project.

Article 9. Ownership of Documents and Intellectual Property

All documents, drawings and specifications, including digital format files, prepared by Artist and furnished to the City as part of the Services shall become the property of the City. Artist shall retain its ownership rights in its design, drawing details, specifications, databases, computer software and other proprietary property. Intellectual property developed, utilized or modified in the performance of the Services shall remain the property of Artist.

Article 10. Independent Contractor Status

During the entire term of this Agreement, Artist shall be an independent contractor, and in no event shall any of its personnel, agents or subcontractors be construed to be, or represent themselves to be, employees of the City. Artist shall be solely responsible for the payment and reporting of all employee and employer taxes, including social security, unemployment, and any other federal, state, or local taxes required to be withheld from employees or payable on behalf of employees.

Article 11. Indemnification

Artist shall defend, indemnify, and hold harmless the City of Bloomington, the City, and the officers, agents and employees of the City and the City from any and all claims, demands, damages, costs, expenses or other liability arising out of the Agreement or occasioned by the reckless or negligent performance of any provision thereof, including, but not limited to, any reckless or negligent act or failure to act or any misconduct on the part of the Artist or its agents or employees, or any independent contractors directly responsible to it (collectively "Claims").

Article 12. Insurance

During the performance of any and all Services under this Agreement, Artist shall maintain the following insurance in full force and effect:

- a. General Liability Insurance, with a minimum combined single limit of \$1,000,000 for each occurrence and \$2,000,000 in the aggregate.
- b. Automobile Liability Insurance, with a minimum combined single limit of \$1,000,000 for each person and \$1,000,000 for each accident.

All insurance policies shall be issued by an insurance company authorized to issue such insurance in the State of Indiana. The City of Bloomington, the City, and the officers, employees and agents of each shall be named as insureds under the General Liability and Automobile policies, and such policies shall stipulate that the insurance will operate as primary insurance and that no other insurance of the City's will be called upon to contribute to a loss hereunder.

Artist shall provide evidence of each insurance policy to the City prior to the commencement of work under this Agreement. Approval of the insurance by the City shall not relieve or decrease the extent to which Artist may be held responsible for payment of damages resulting from Artist's provision of the Services or its operations under this Agreement. If Artist fails or refuses to procure or maintain the insurance required by these provisions, or fails or refuses to furnish the City's required proof that the insurance has been procured and is in force and paid for, the City shall have the right at its election to terminate the Agreement.

Article 13. Conflict of Interest

Artist declares that it has no present interest, nor shall it acquire any interest, direct or indirect, which would conflict with the performance of Services under this Agreement. Artist agrees that no person having any such interest shall be employed in the performance of this Agreement.

Article 14. Waiver

No failure of either party to enforce a term of this Agreement against the other shall be construed as a waiver of that term, nor shall it in any way affect the party's right to enforce that term. No waiver by any party of any term of this Agreement shall be considered to be a waiver of any other term or breach thereof.

Article 15. Severability

The invalidity, illegality or unenforceability of any provision of this Agreement or the occurrence of any event rendering any portion or provision of this Agreement void shall in no way affect the validity or enforceability of any other portion or provision of this Agreement. Any void provision shall be deemed severed from this Agreement, and the balance of the Agreement shall be construed and enforced as if it did not contain the particular provision to be held void. The parties further agree to amend this Agreement to replace any stricken provision with a valid provision that comes as close as possible to the intent of the stricken provision. The provisions of this Article shall not prevent this entire Agreement from being void should a provision which is of the essence of this Agreement be determined void.

Article 16. Assignment

Neither the City nor the Artist shall assign any rights or duties under this Agreement without the prior written consent of the other party. Unless otherwise stated in the written consent to an assignment, no assignment will release or discharge the assignor from any obligation under this Agreement.

Article 17. Third Party Rights

Nothing in this Agreement shall be construed to give any rights or benefits to anyone other than the City and Artist.

Article 18. Governing Law and Venue

This Agreement shall be governed by the laws of the State of Indiana. Venue of any disputes arising under this Agreement shall be in the Monroe Circuit Court, Monroe County, Indiana.

Article 19. Non-Discrimination

Artist shall comply with City of Bloomington Ordinance 2.21.020 and all other federal, state and local laws and regulations governing non-discrimination in all regards, including, but not limited to, employment.

Artist understands that the City of Bloomington prohibits its employees from engaging in harassment or discrimination of any kind, including harassing or discriminating against independent contractors doing work for the City. If Artist believes that a City employee engaged in such conduct towards Artist and/or any of its employees, Artist or its employees may file a complaint with the City, City head in charge of the Artist work, and/or with the City Human Resources Department, or the Bloomington Human Rights Commission. The City takes all complaints of harassment and discrimination seriously and will take appropriate disciplinary action if it finds that any City employee engaged in such prohibited conduct.

Article 20. Compliance with Laws

In performing the Services under this Agreement, Artist shall comply with any and all applicable federal, state and local statutes, ordinances, plans and regulations, including any and all regulations for protection of the environment. Where such statutes, ordinances, plans or regulations of any public authority having any jurisdiction over the project are in conflict, Artist shall proceed using its best judgment only after attempting to resolve any such conflict between such governmental agencies, and shall notify the City in a timely manner of the conflict, attempts of resolution, and planned course of action.

Article 21. E-Verify

If applicable, Artist is required to enroll in and verify the work eligibility status of all newly-hired employees through the E-Verify program. (This is not required if the E-Verify program no longer exists). Artist shall sign an affidavit, attached as Exhibit C, affirming that Artist does not knowingly employ an unauthorized alien. "Unauthorized alien" is defined at 8 U.S. Code 1324a(h)(3) as a person who is not a U.S. citizen or U.S. national and is not lawfully admitted for permanent residence or authorized to work in the U.S. under 8 U.S. Code chapter 12 or by the U.S. Attorney General.

Article 22. Notices

Any notice required by this Agreement shall be made in writing to the individuals/addresses specified below:

City:

City of Bloomington
Attn: Holly Warren
401 N. Morton, Suite 150
Bloomington, Indiana 47402

Artist:

Erin Tobey
806 W 2nd St
Bloomington, IN 47403

Nothing contained in this Article shall be construed to restrict the transmission of routine communications between representatives of the City and Artist.

Article 23. Intent to be Bound

The City and Artist each binds itself and its successors, executors, administrators, permitted assigns, legal representatives and, in the case of a partnership, its partners to the other party to this Agreement, and to the successors, executors, administrators, permitted assigns, legal representatives and partners of such other party in respect to all provisions of this Agreement.

Article 24. Integration and Modification

This Agreement, including all Exhibits incorporated by reference, represents the entire and integrated agreement between the City and the Artist. It supersedes all prior and contemporaneous communications, representations and agreements, whether oral or written, relating to the subject matter of this Agreement. This Agreement may be modified only by a written amendment signed by both parties hereto.

IN WITNESS WHEREOF, the parties hereto have caused this Agreement to be executed the day and year first written above.

CITY OF BLOOMINGTON

ERIN TOBEY

DocuSigned by:
Margie Rice
E9A0FAE19B82413

Margie Rice, Corporation Counsel

DocuSigned by:
Erin Tobey
19F57590D1A24D6...

Erin Tobey

DocuSigned by:
Jane Kupersmith
AA8B777073874E4...

Jane Kupersmith, Director

EXHIBIT A

“Scope of Work”

The Services shall include the following:

The execution of approved mural designs on five traffic calming circles (depicted below) located on W. 6th and W. 7th streets in Bloomington Indiana, approximating 460 sq. ft. total surface area, and estimating 60-80 hours of work.

The project will be completed by January 1, 2025, contingent on material availability.



6th and Waldron



6th and Oak



7th and Waldron



7th and Oak



7th and Pine

ERIN TOBEY | ART + DESIGN

806 W 2nd Street, Bloomington, Ind., 47403 | erintobey@gmail.com | (812) 671-3804

INVOICE

DATE: 03/01/24
INVOICE #: 2403

CLIENT:

The City of Bloomington
Department of Economic & Sustainable Development
ATTN: Chaz Mottinger, Holly Warren

PROJECT:

Near West Side Roundabout Murals

DESCRIPTION	PRICE	ARTICLES	TOTAL
Design	\$200	5	\$1,000
Painting Labor	\$8/square foot	460 ft ²	\$3,680
Materials	assorted	assorted	\$500
TOTAL BUDGET ESTIMATE =			\$5,180

CONCEPT SUMMARY:

Botanical motifs featuring plants that are familiar in the NWS neighborhood: peonies (pink), Black-eyed Susans & aromatic asters (yellow & purple), dogwood (white), Winterberry (red), fall leaves (reds/oranges: Maple, Oak, Tulip Tree, Redbud). Each roundabout will feature one or two plants and its branches, leaves and/or blooms using three colors (colors may repeat among the murals). Some animal friends may appear as fun easter eggs (cats, birds, chickens, skunks).



EXHIBIT B
City of Bloomington Policy and Procedures on
Private Art Installations within the Public Right of Way

[See attached]



City of Bloomington Policy and Procedures on Private Art Installations within the Public Right of Way

The City of Bloomington’s Policy and Procedures on Private Art Installations within the Public Right of Way (“Policy”) authorizes private Art Installations in the public right of way that comply with this document and are approved through one of two City programs: (1) the Neighborhood Improvement Grant Program or (2) a Special Event Application.

This Policy is designed to reduce the risks to public safety and burden on public resources that private Art Installations within the right of way may impose while simultaneously recognizing the importance of private as well as public art to Bloomington’s culture, community, and economy.

- I. Definitions. The following definitions shall apply throughout this policy.
 - A. Temporary Art. Art expected to remain in place within the public right of way for seven (7) or fewer days.
 - B. Semi-Permanent Art or Permanent Art. Art expected to remain in place within the public right of way for more than seven (7) days.
 - C. Art Installation. Temporary, Semi-Permanent, or Permanent Art that consists of a physical alteration of the right of way, such as a painting, mural, or sculpture and that is not Performative Art.
 - D. Street Painting or Street Mural. Art involving the placement of paint or a similar material within the area where vehicles drive or park, commonly understood to be the space “between the curbs.”
 - E. Performative Art. A time-based art form that is an ephemeral event featuring a live presentation to an audience, drawing on such arts as acting, poetry, music, or dance, and that does not involve the creation of an artifact (such as a painting or sculpture) that physically alters the right of way beyond the time of the live performance.

F. Speech. Words, letters, numbers, universally recognized symbols, or logos of any kind.

II. Performative Art. This policy does not apply to Performative Art.¹

III. Criteria Applicable to All Private Art Installations. The following criteria are applicable to any private Art Installation proposed within Bloomington's right of way, whether the Art Installation is Temporary Art, Semi-Permanent Art, or Permanent Art.

A. Requests must be submitted to the appropriate City Department(s) and/or Board(s) or Commission(s), as required by the selected program application identified in Section VI below. Staff shall provide a recommendation on the request to the appropriate Board(s) or Commission(s) based on the request's compliance with this Policy and any other applicable laws, rules, or City of Bloomington policies.

B. Art Installations may not use or incorporate copyrighted material in whole or part where the copyright is not owned by the artist.

C. Art Installations may not mimic in whole or part traffic control devices including but not limited to a crosswalk, stop sign, stop bar, or similar traffic control device. Art Installation geometry should be such that drivers do not alter their course to drive around the art.

D. Art Installations may not depict activities, materials, images, or products that are not legally available to all ages.

IV. Additional Criteria Applicable to Semi-Permanent Art Installations or Permanent Art Installations.

A. Applications for approval of a Semi-Permanent or Permanent Art Installation within the right of way must include the following:

1. An accurate depiction of the design to scale;
2. Dimensions;
3. A map of proposed location of the design; and
4. The name and qualifications of the artist.

¹ Though this Policy does not apply to Performative Art taking place within the right of way, other municipal policies or ordinances may apply that impact Performative Art within the right of way, including but not limited to the City's parade ordinance or special event application process.

B. Semi-Permanent Art Installations or Permanent Art Installations may not contain Speech.

V. Additional Criteria Applicable to Street Paintings or Street Murals. Because paintings and murals within the street create a heightened probability of conflicts with traffic control devices and driver distraction, the following additional criteria apply to all paintings or murals proposed for street surfaces, whether as Temporary, Semi-Permanent, or Permanent Art Installations.

A. Applications for approval of a Street Painting or Street Mural within the right of way must include the following:

1. An accurate depiction of the design to scale;
2. Dimensions;
3. A map of proposed location of the design; and
4. The name and qualifications of the artist.

B. Street paintings and street murals may only be placed on streets with a local or secondary collector functional classification under the City's Transportation Plan, where regulatory speed limits do not exceed 25 miles per hour.

C. Street paintings and street murals may only be placed on pavement in adequate condition for materials to bond.

D. Street paintings and street murals are not permitted on brick, paver, or other decorative surface materials (e.g., colored or stamped concrete). Street paintings and street murals are only permitted on standard non-decorative concrete or asphalt.

E. A buffer of four feet must remain between street paintings and street murals and any crosswalk.

F. Within an intersection, street paintings and street murals are only allowed where the intersection utilizes all-way stop control, unless the painting or mural is located on an apron.

G. Street paintings and street murals may not be painted on the side or top of any curb or any curb ramp.

H. Materials used must be approved by the City's Engineering Department.

- I. Any paint or similar material utilized as part of any street painting or street mural must provide a non-slip surface for pedestrians and must be street-grade.

VI. Programs. Individuals and external organizations seeking to place private Art Installations within the public right of way must apply pursuant to one of the programs listed below and follow the procedures associated with the program, which are linked and attached hereto for reference. Requests to place an Art Installation in the City's right of way using a program or procedure other than those listed below will not be considered.

A. Neighborhood Improvement Grant Program

1. Applications for Art Installations within the right of way pursuant to the Neighborhood Improvement Grant Programs must comply with Program guidelines, the criteria set forth in this Policy, and any additional logistical or safety conditions imposed by the Board of Public Works as part of its approval.
2. Neighborhood Improvement Grant Program guidelines may be accessed [here](#)² and are attached for reference.

B. Special Event Permit

1. A special event application may be submitted for permission to conduct an event during which an Art Installation will be placed in the public right of way. The proposed Art Installation must comply with the criteria set forth in this policy, the requirements set forth in the special event permit application, and any additional logistical or safety conditions imposed by the Board of Public Works as part of its approval.
2. A special event application may be accessed [here](#)³ and is attached for reference.

² <https://bloomington.in.gov/neighborhoods/grants/improvement>

³ <https://bloomington.in.gov/departments/esd>

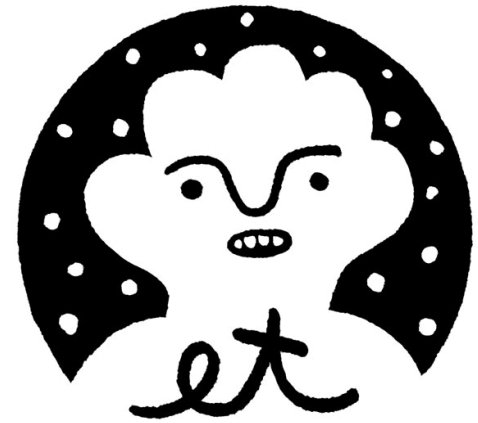

Clients:

City of Bloomington

Near West Side Neighborhood Association

Project:

Roundabout Murals

8/1/24 v1

DESIGN #1
"PEONIES"



DESIGN #1
"SHADE GARDEN"



DESIGN #1
"FALL LEAVES"



DESIGN #1
"CONEFLOWERS"



DESIGN #1
"SUMMER FRUITS"





erin tobey
murals + design





W 7th St

W 7th St

W

N Elm St

N Waldron St

N Maple St

Type 3 Barricades w/
Road Closed Signage

W 6th St

W 6th St

W 6th St

W

N Waldron St

N Maple St

Suggested Type 3
Barricades w/ Road
Closed to Through
Traffic Signage

Bloomington Farm
Stop Collective
Farm shop

Rose Hill FARM STOP

Red Carpet Cuts

N Waldron St

N Maple St

W Kirkwood Ave

W Kirkwood Ave

W Kirkwood Ave

W Kirkwood Ave

W Kirkwood

n St

St

St



Board of Public Works Staff Report

Project/Event:	Permit extension request for City-wide Fiber Project
Staff Representative:	Kyle Baugh
Petitioner/Representative:	Bret Simons / Jerrod Gabriel
Date:	September 10 th , 2024

Report: AEG is requesting extensions of eight permits that were previously approved by the Board of Public Works. These permits include lane and sidewalk closures at various locations across the city. AEG states that the extensions are being required as there were unforeseen delays in their previous requests, such as utility locating not being completed in a timely manner, weather, and needing to complete final restoration work in areas.

The extension dates are listed within their request letter for each permit zone. Six permits of the eight permits are requesting extensions to September 30th, 2024 and the other two are requested for October 30th, 2024.



P.O. Box 349 | Buford, Georgia 30515

Main Office: (706)654-2298

www.aeg.cc

To: City of Bloomington – Engineering Department

Subject: City of Bloomington Right of Way Extension

Dear Board Members,

AEG is respectfully requesting an extension to access the ROWs on expired permits in the city.

We are asking for extensions on the following permits. We were unable to finish or start work in these areas due to unforeseen circumstances (Pole Co-op not responding in a timely manner, locates failing to be called out and Weather).

BLN01b-F12_N Hay St – Work to be completed by Sept 30th

BLN01b-F11_N Williams St – Work to be completed by Sept 30th

BLC02a-F14_S Maxwell St – Work to be completed by Sept 30th

BLC02a-F07_E Moody Dr – Work to be completed by Oct 30th

BLN01b-F10_N Morton St – Work to be completed by Oct 30th

BLN01b-F09_N Lincoln St – Work to be completed by Sept 30th

BLN01a-F02_E 19th St – Work to be completed by Sept 30th

BLN01b-F13_N Crescent Rd – Work to be completed by Sept 30th

Bret Simons

Engineering Permit Team Lead

Atlantic Engineering Group

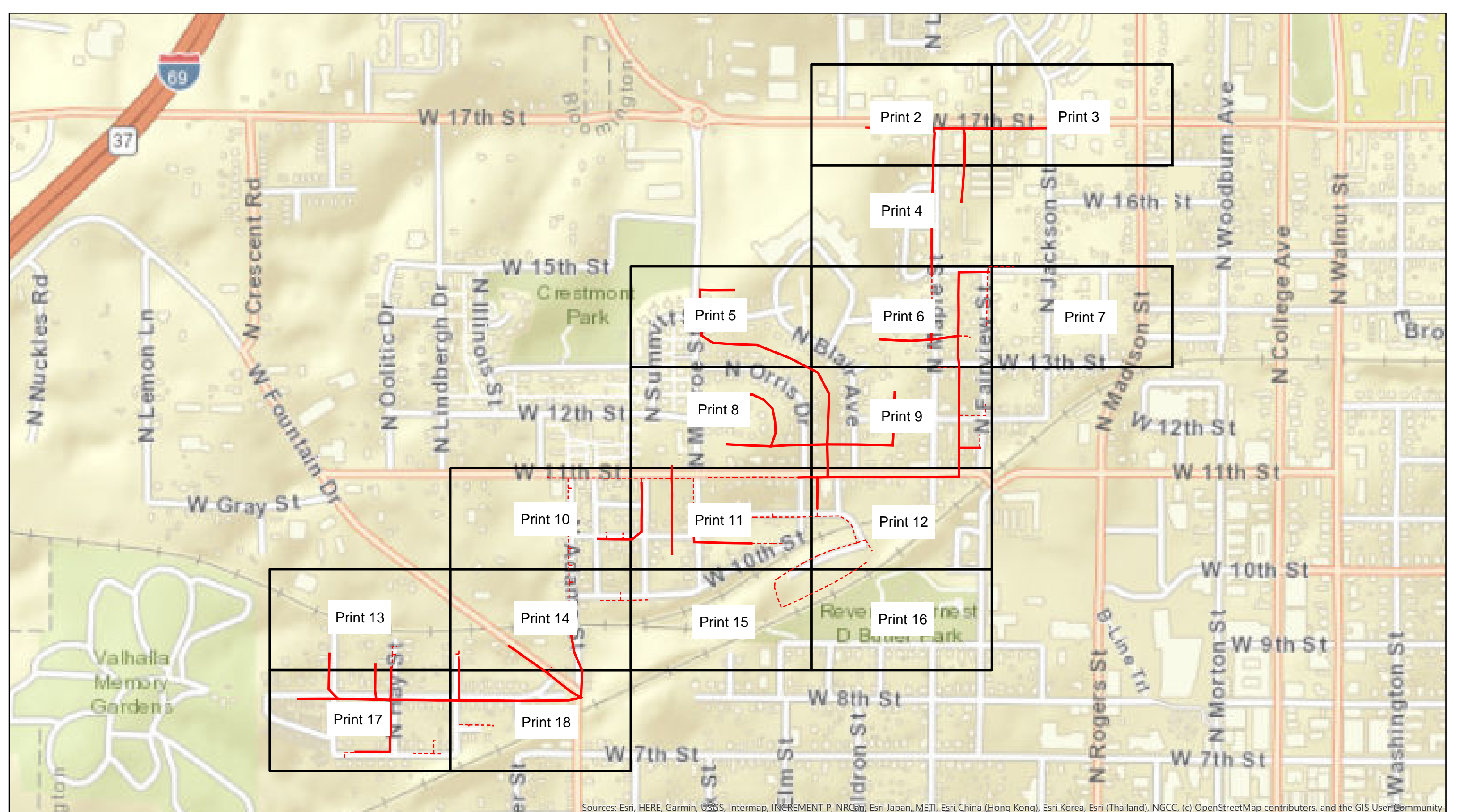

Sources: Esri, HERE, Garmin, USGS, Intermap, INCREMENT P, NRCan, Esri Japan, METI, Esri China (Hong Kong), Esri Korea, Esri (Thailand), NGCC, (c) OpenStreetMap contributors, and the GIS User Community



Legend BLN01b-F12_N Hay St

- Overhead Strand
- - - Conduit
- Grids

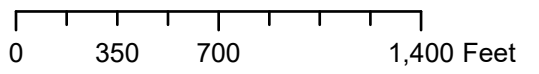

City of Bloomington, IN Permit:
Design View

INI	BY	DATE	DESCRIPTION



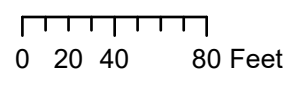
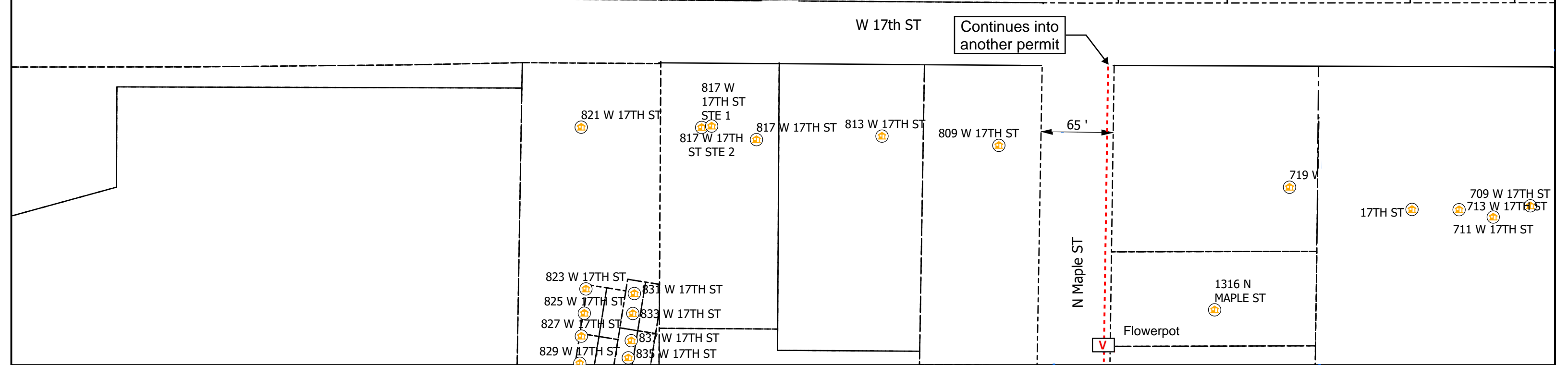
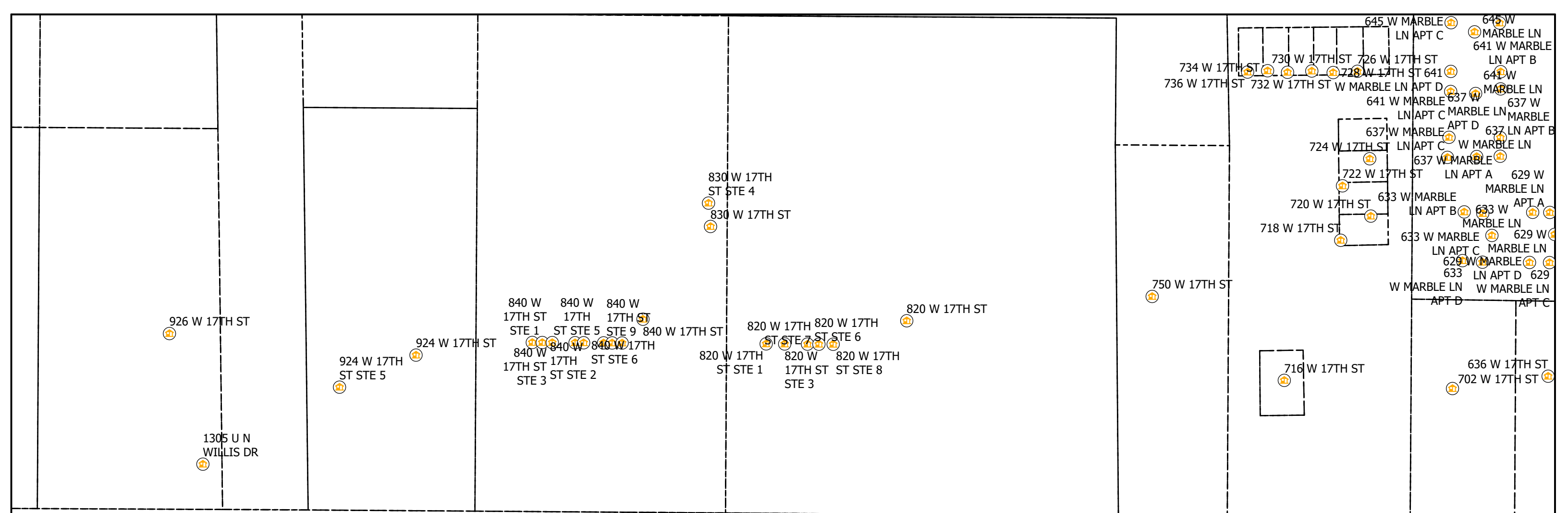

Legend

- Poles
- V Vaults
- Overhead Strand
- Conduit
- Bloomington_Parcels
- Ⓡ Risers
- Ⓜ Address
- Y Anchor
- ↖ Sidewalk
- Grids

All Flowerpots 12" DIA



City of Bloomington, IN Permit:
Design View

INI	BY	DATE	DESCRIPTION



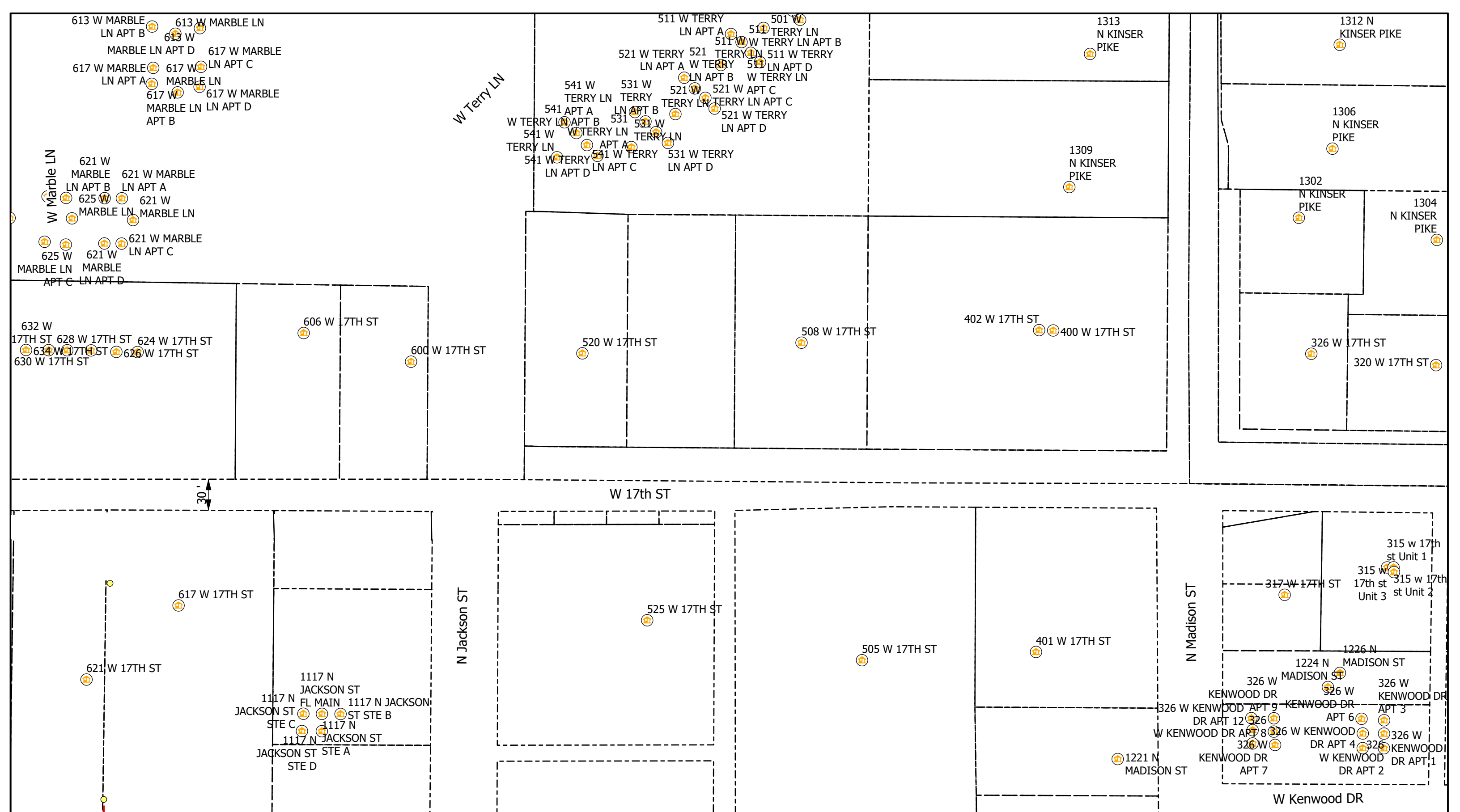

Legend

- Poles
- V Vaults
- Overhead Strand
- Conduit
- Bloomington_Parcels
- R Risers
- A Address
- Y Anchor
- ← Sidewalk
- Grids

All Flowerpots 12" DIA



City of Bloomington, IN Permit:
Design View

INI	BY	DATE	DESCRIPTION



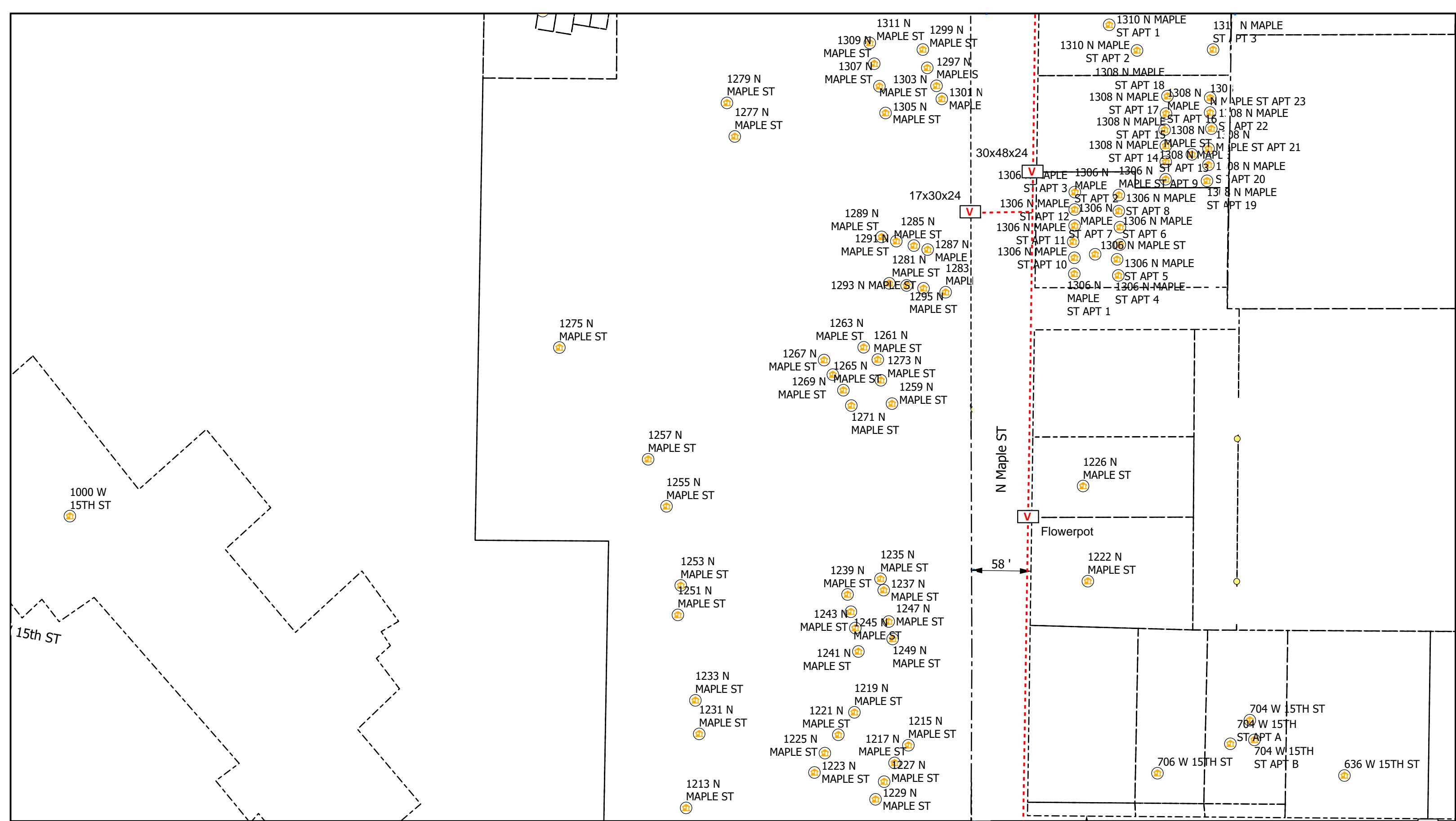

0 20 40 80 Feet

Legend

- Poles
- V Vaults
- Overhead Strand
- Conduit
- Bloomington_Parcels
- R Risers
- A Address
- Y Anchor
- ← Sidewalk
- Grids

All Flowerpots 12" DIA



City of Bloomington, IN Permit:
Design View

INI	BY	DATE	DESCRIPTION



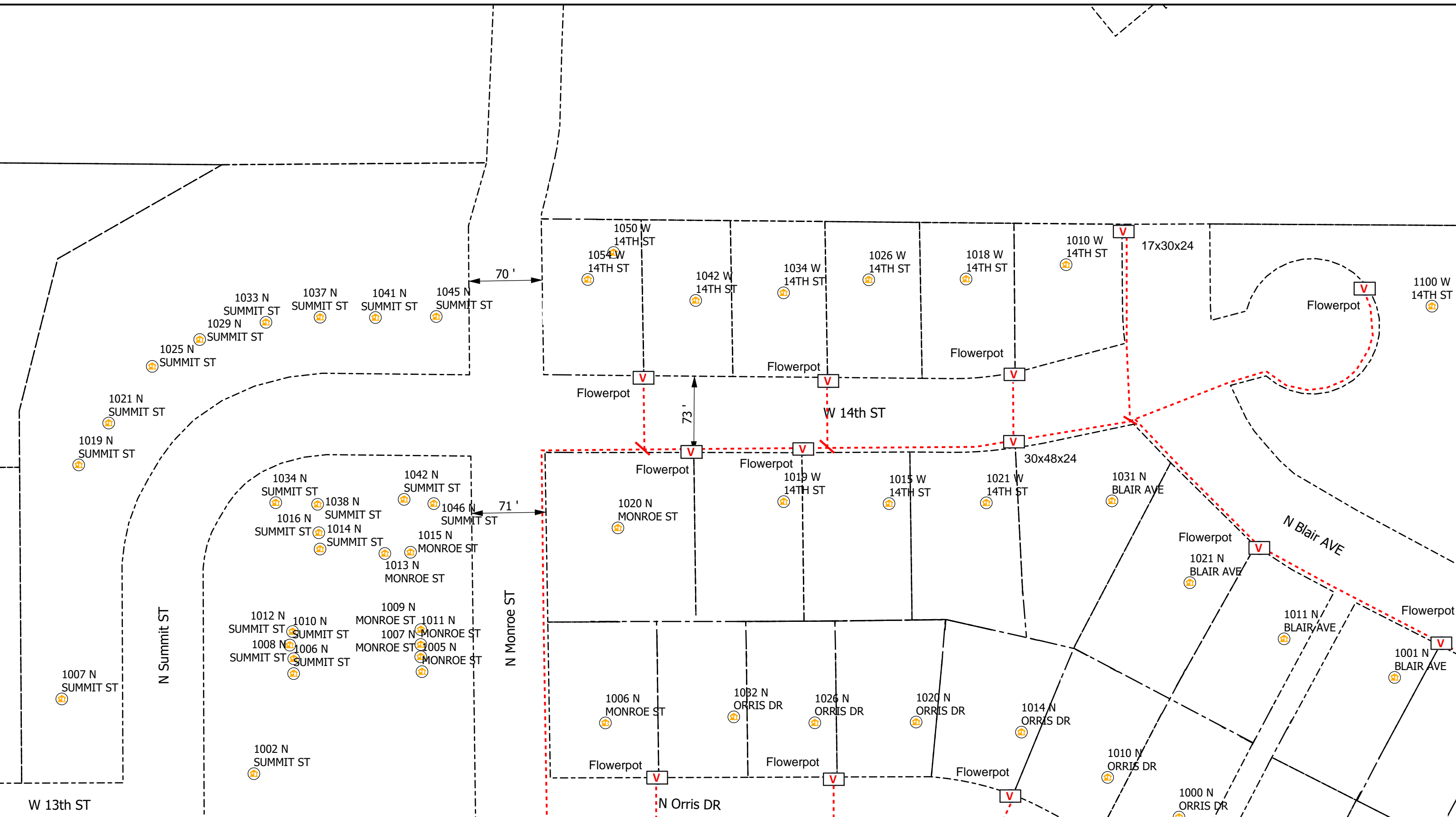

AEG

0 20 40 80 Feet

Legend

- Poles
- Vaults
- Overhead Strand
- Conduit
- Bloomington_Parcels
- Risers
- Address
- Anchor
- Sidewalk
- Grids

All Flowerpots 12" DIA

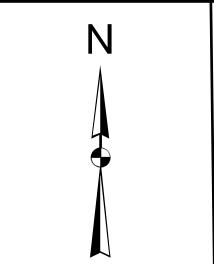

City of Bloomington, IN Permit:
Design View

INI	BY	DATE	DESCRIPTION

Indiana 811

Print 5 of 18

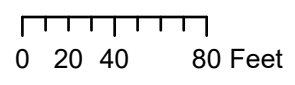
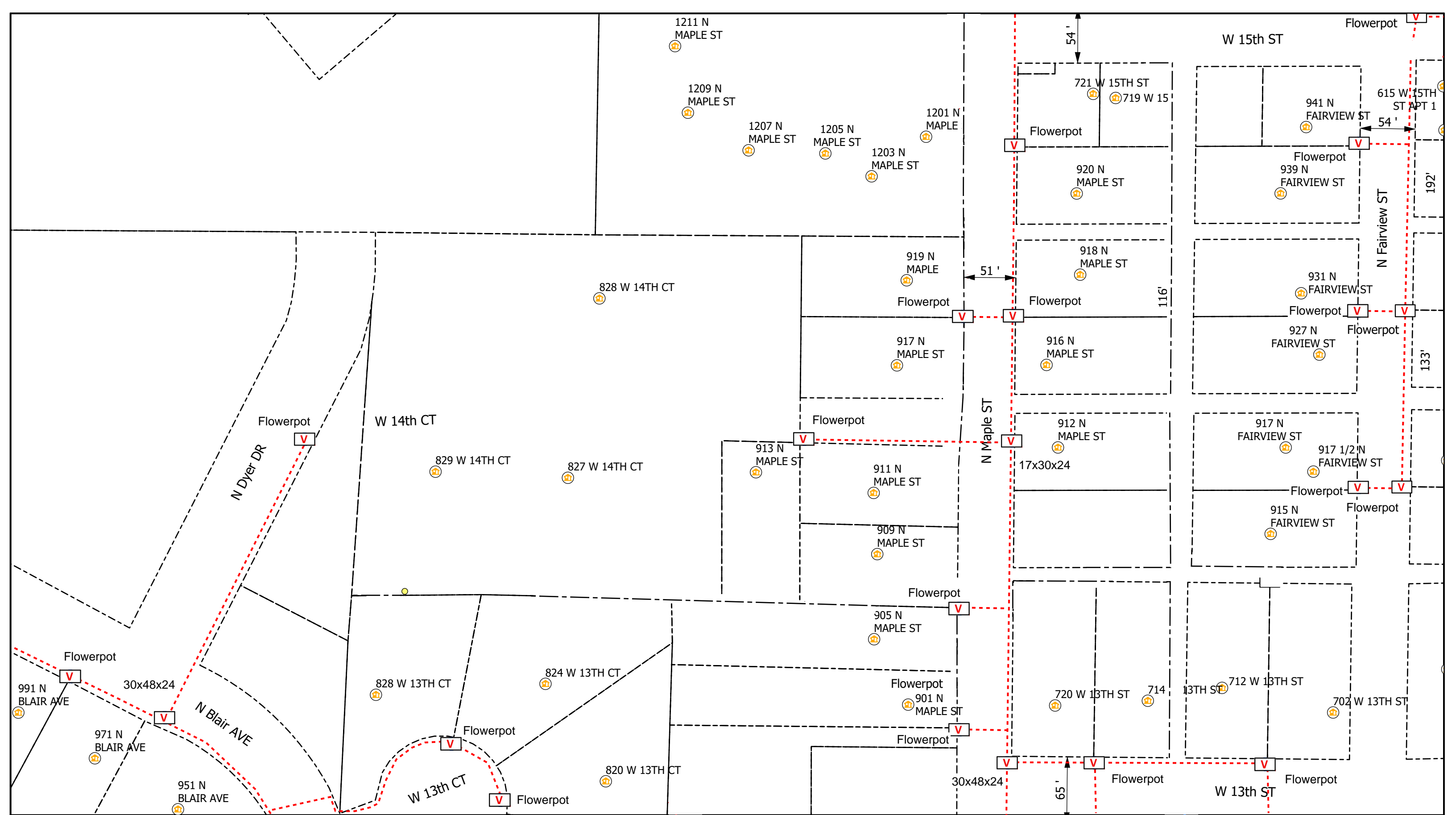

Legend

- Poles
- V Vaults
- Overhead Strand
- Conduit
- Bloomington_Parcels
- R Risers
- A Address
- Y Anchor
- ← Sidewalk
- Grids

All Flowerpots 12" DIA



City of Bloomington, IN Permit:
Design View

INI	BY	DATE	DESCRIPTION



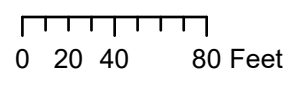
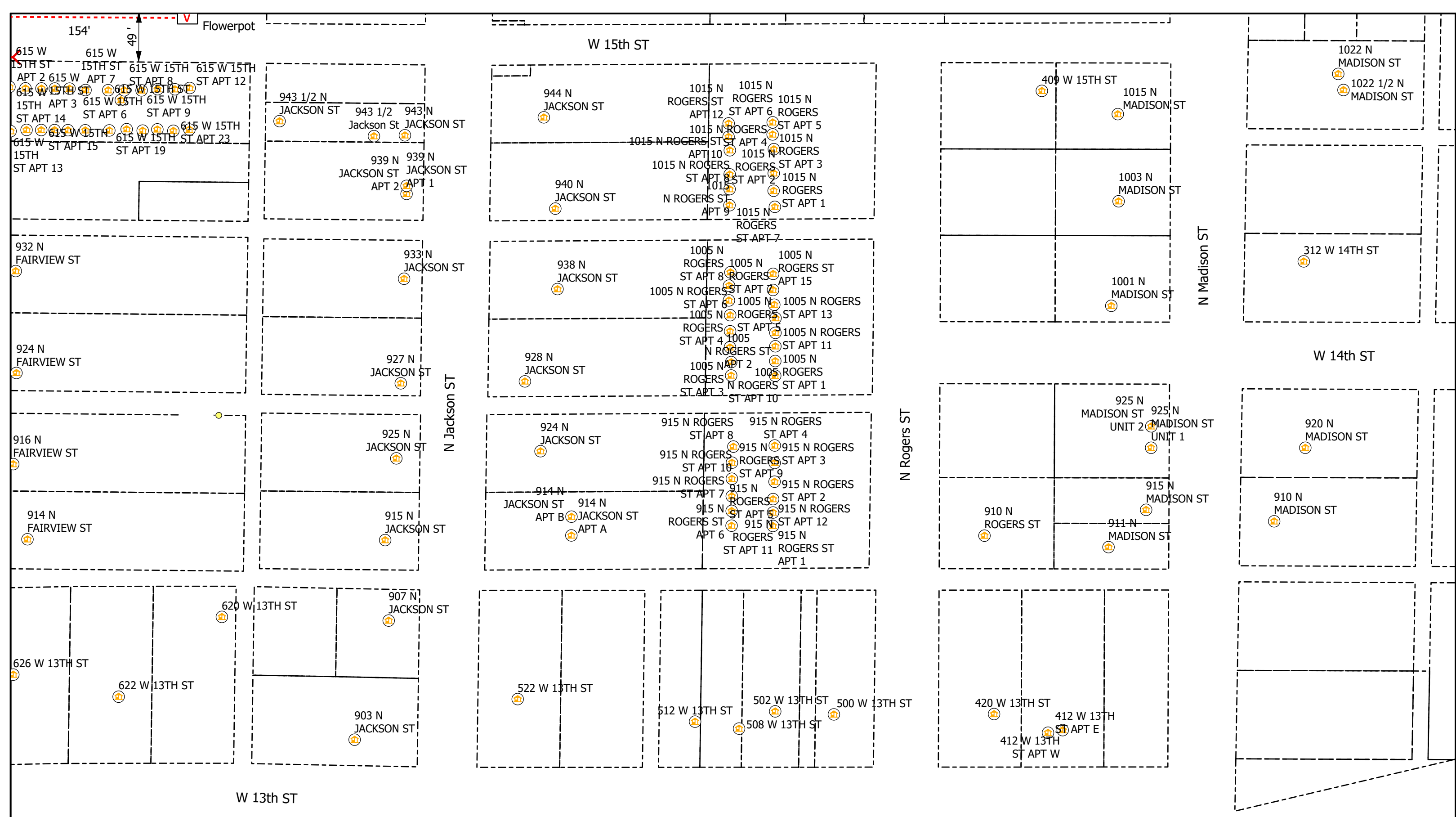

Legend

- Poles
- V Vaults
- Overhead Strand
- Conduit
- Bloomington_Parcels
- R Risers
- A Address
- Y Anchor
- ← Sidewalk
- Grids

All Flowerpots 12" DIA



City of Bloomington, IN Permit:
Design View

INI	BY	DATE	DESCRIPTION



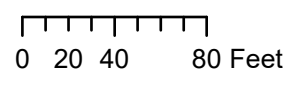
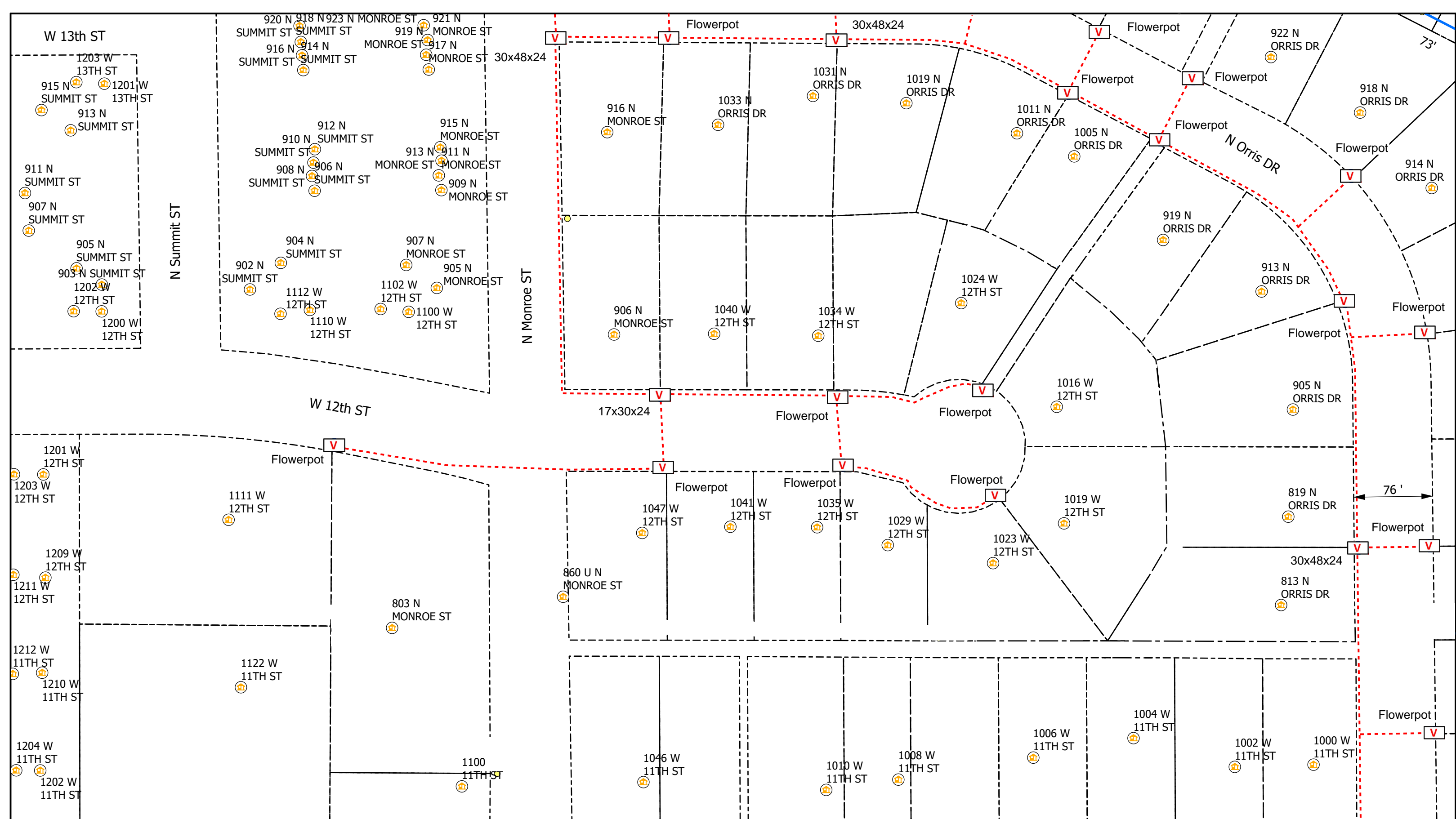

Legend

- Poles
- Vaults
- Overhead Strand
- Conduit
- Risers
- Address
- Bloomington_Parcels
- Anchor
- Sidewalk
- Grids

All Flowerpots 12" DIA



City of Bloomington, IN Permit:
Design View

INI	BY	DATE	DESCRIPTION



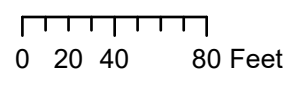
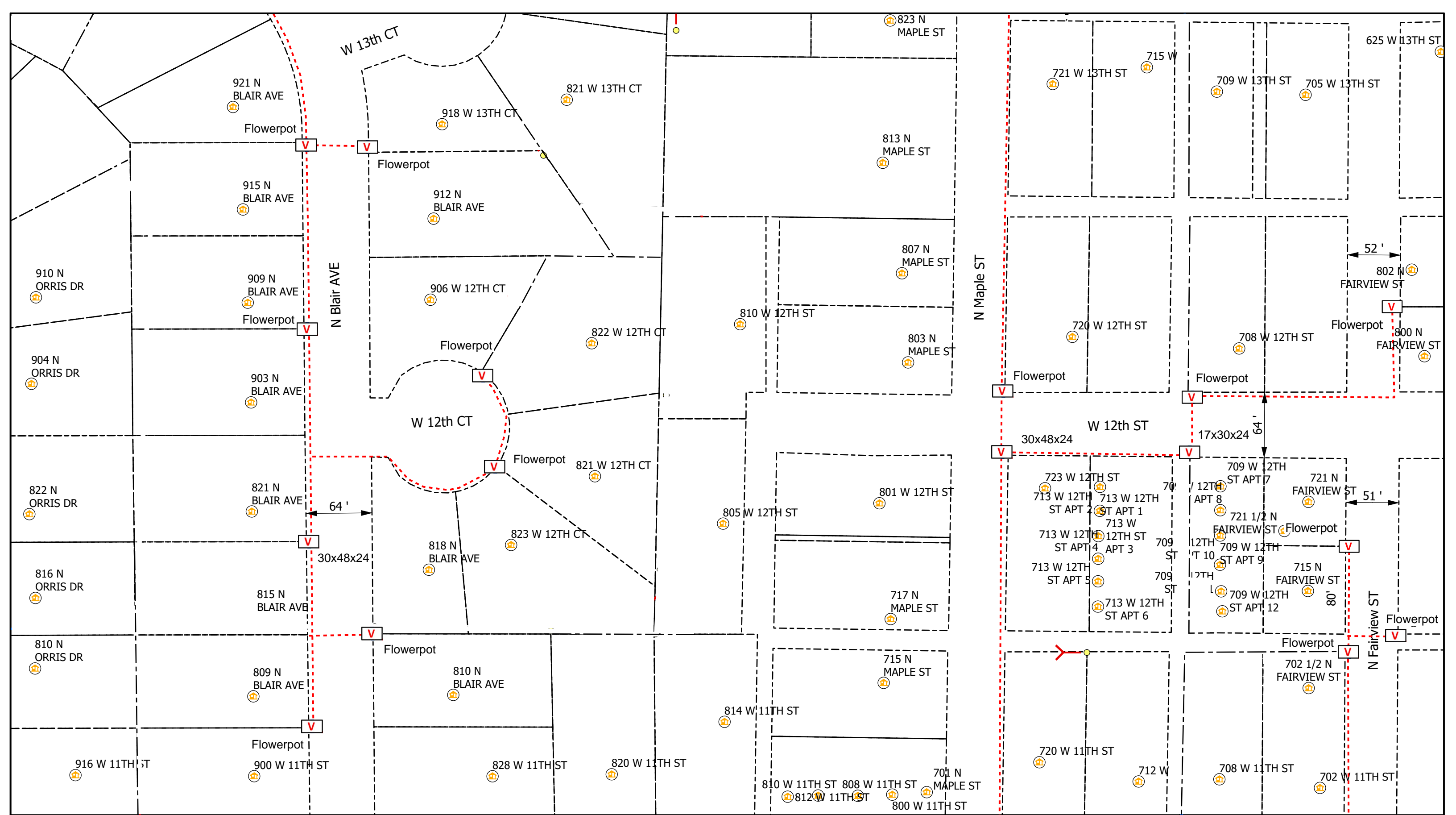

Legend

- Poles
- Vaults
- Overhead Strand
- Conduit
- Bloomington_Parcels
- Risers
- Address
- Anchor
- Sidewalk
- Grids

All Flowerpots 12" DIA



City of Bloomington, IN Permit:
Design View

INI	BY	DATE	DESCRIPTION



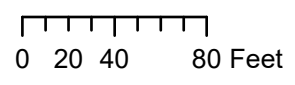
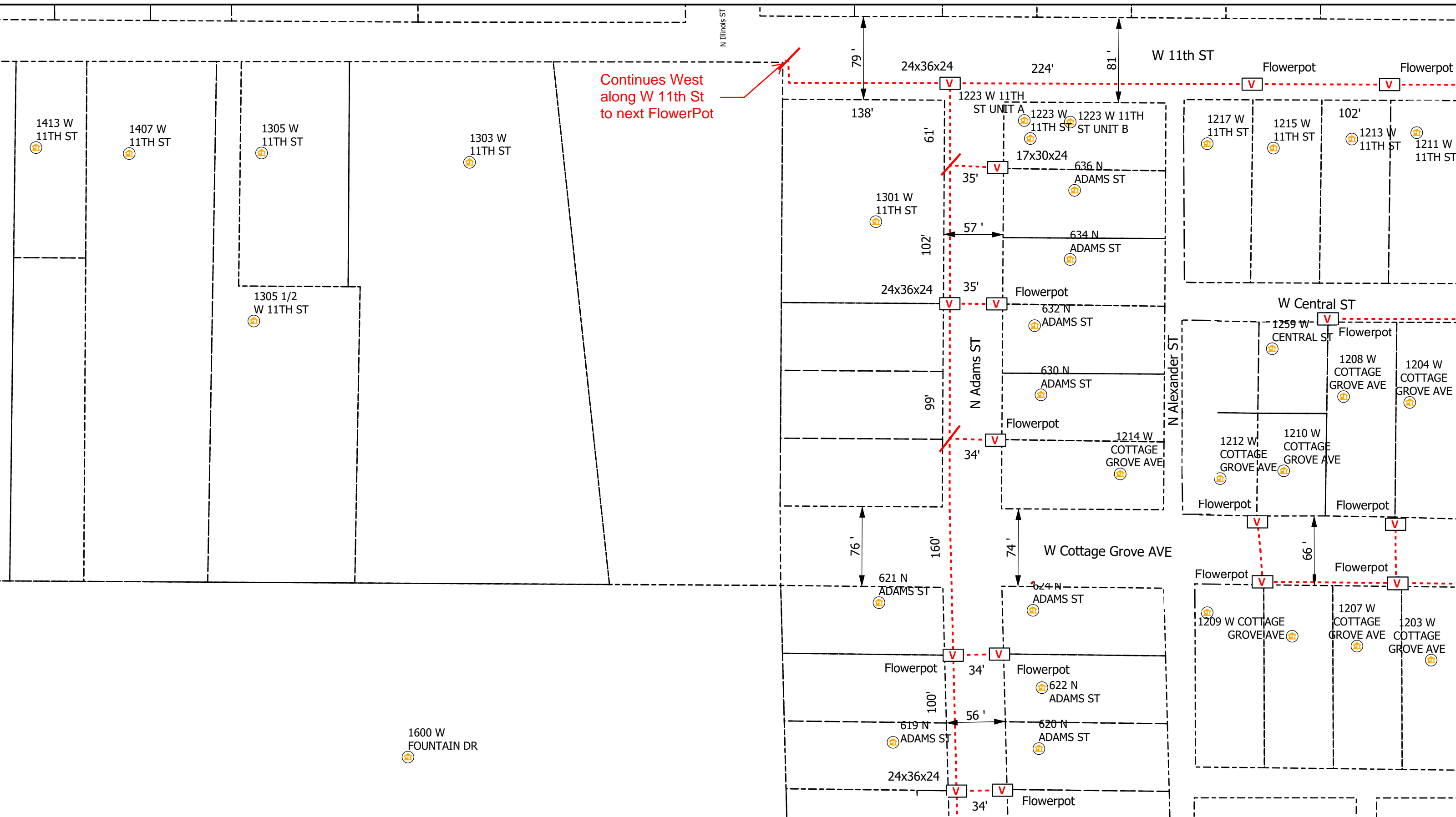

Legend

- Poles
- V Vaults
- Overhead Strand
- - - Conduit
- Bloomington_Parcels
- R Risers
- A Address
- Y Anchor
- ← Sidewalk
- Grids

All Flowerpots 12" DIA



City of Bloomington, IN Permit:
Design View

INI	BY	DATE	DESCRIPTION



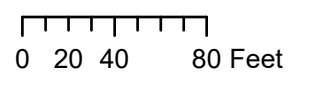
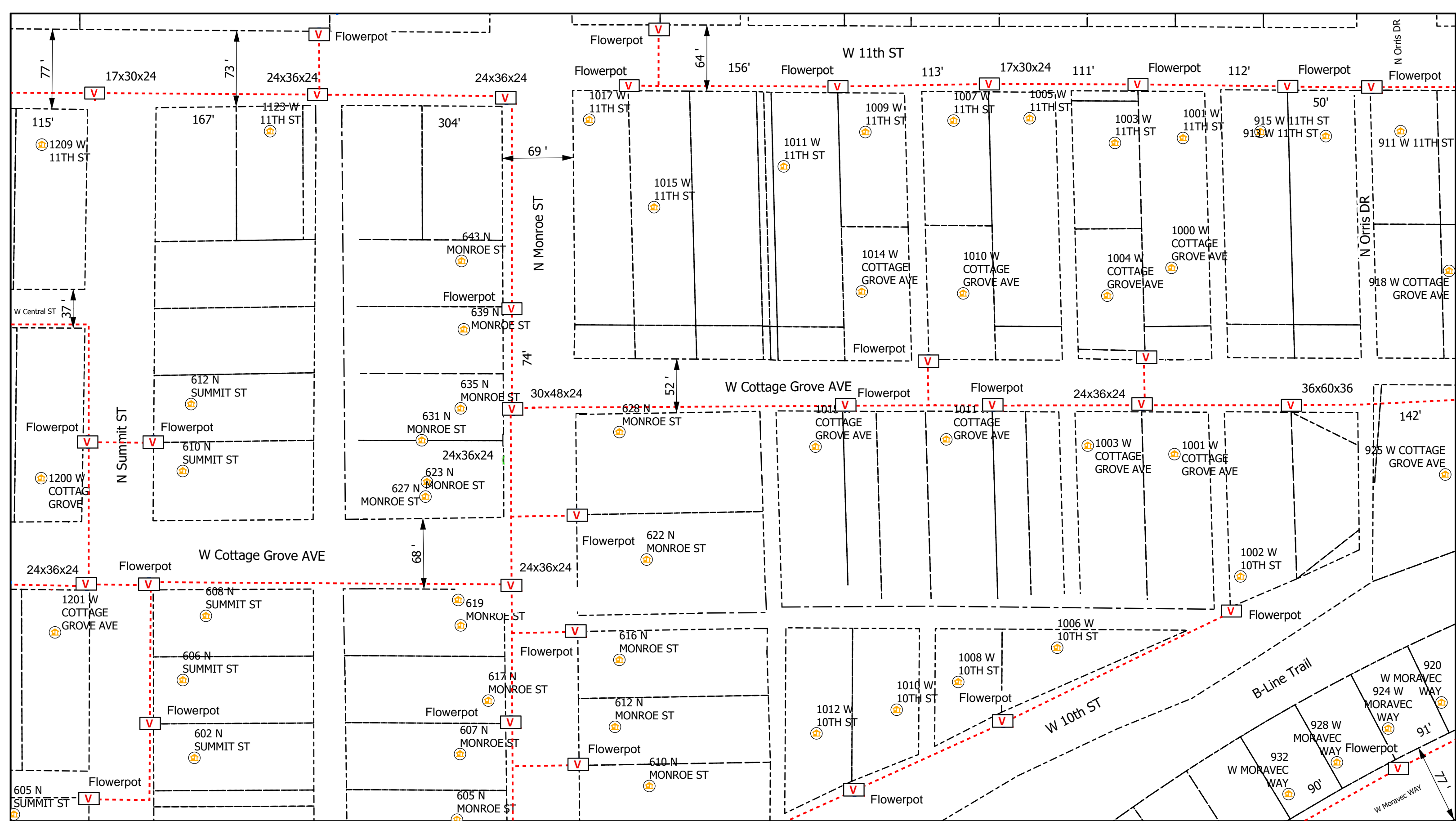

Legend

- Poles
- V Vaults
- Overhead Strand
- Conduit
- Bloomington_Parcels
- R Risers
- A Address
- Y Anchor
- ← Sidewalk
- Grids

All Flowerpots 12" DIA



City of Bloomington, IN Permit:
Design View

INI	BY	DATE	DESCRIPTION



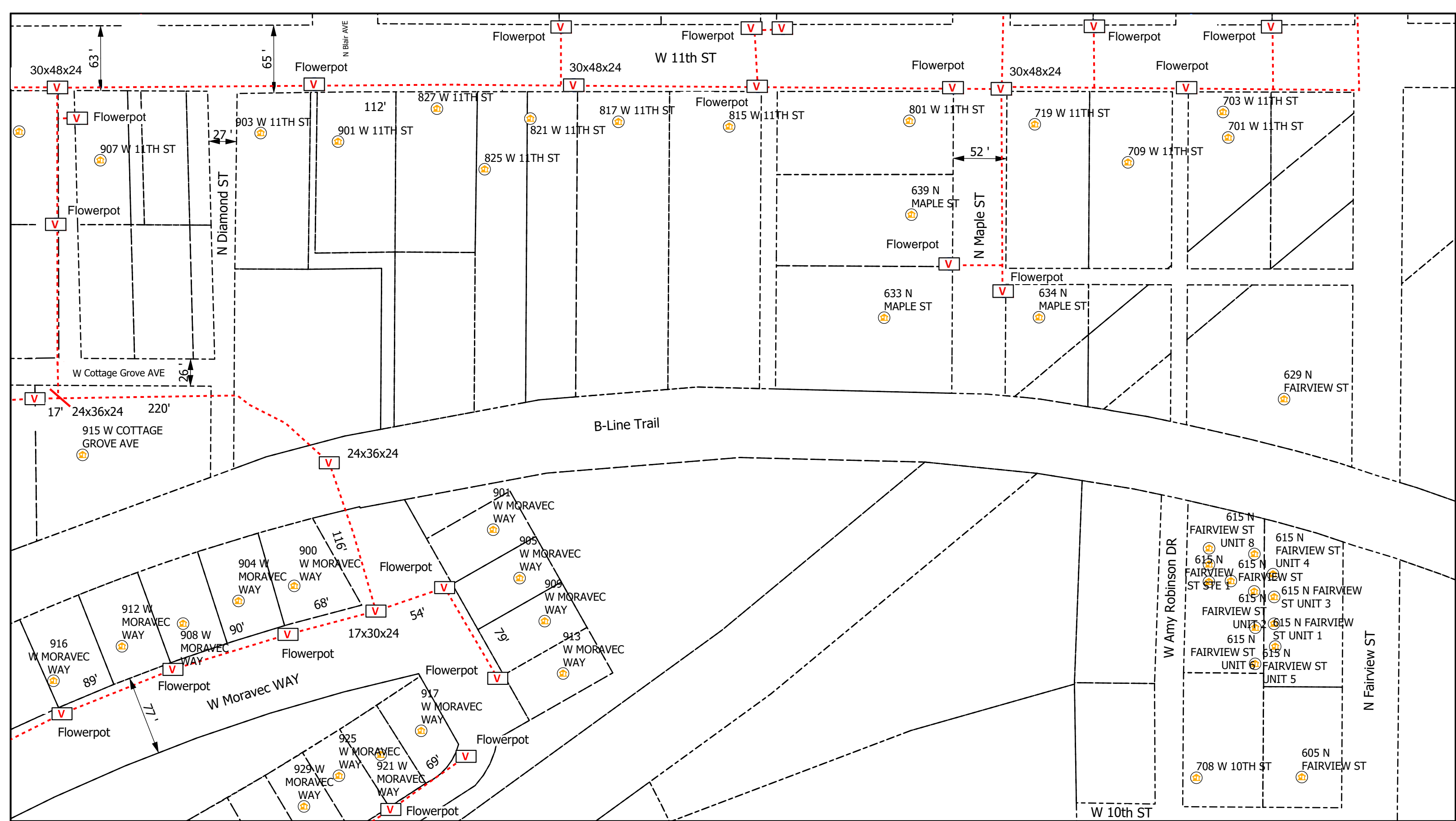

0 20 40 80 Feet

Legend

- Poles
- Vaults
- Overhead Strand
- Conduit
- Bloomington_Parcels
- Risers
- Address
- Anchor
- Sidewalk
- Grids

All Flowerpots 12" DIA



City of Bloomington, IN Permit:
Design View

INI	BY	DATE	DESCRIPTION



620 N NORTH ST

1803 W FOUNTAIN DR

W Fountain DR

415 N SPRING ST

Flowerpot

60'

413 N SPRING ST

Flowerpot

411 N SPRING ST

N Spring ST

410 N SPRING ST

Flowerpot

406 N SPRING ST

Flowerpot

1634 W 8TH ST

1630 W 8TH ST

Anchor

425 N HAY ST

Flowerpot

417 N HAY ST

N Hay ST

45'

Flowerpot

428 N HAY ST

424 N HAY ST

Flowerpot

420 N HAY ST

429 N HOPEWELL ST

421 N HOPEWELL ST

405 N HOPEWELL ST

1706 W 8TH ST



0 20 40 80 Feet

Legend

- Poles
- Vaults
- Overhead Strand
- Conduit
- Bloomington_Parcels
- Risers
- Address
- Anchor
- Sidewalk
- Grids

All Flowerpots 12" DIA

N



City of Bloomington, IN Permit:
Design View

INI	BY	DATE	DESCRIPTION



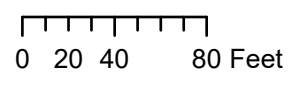
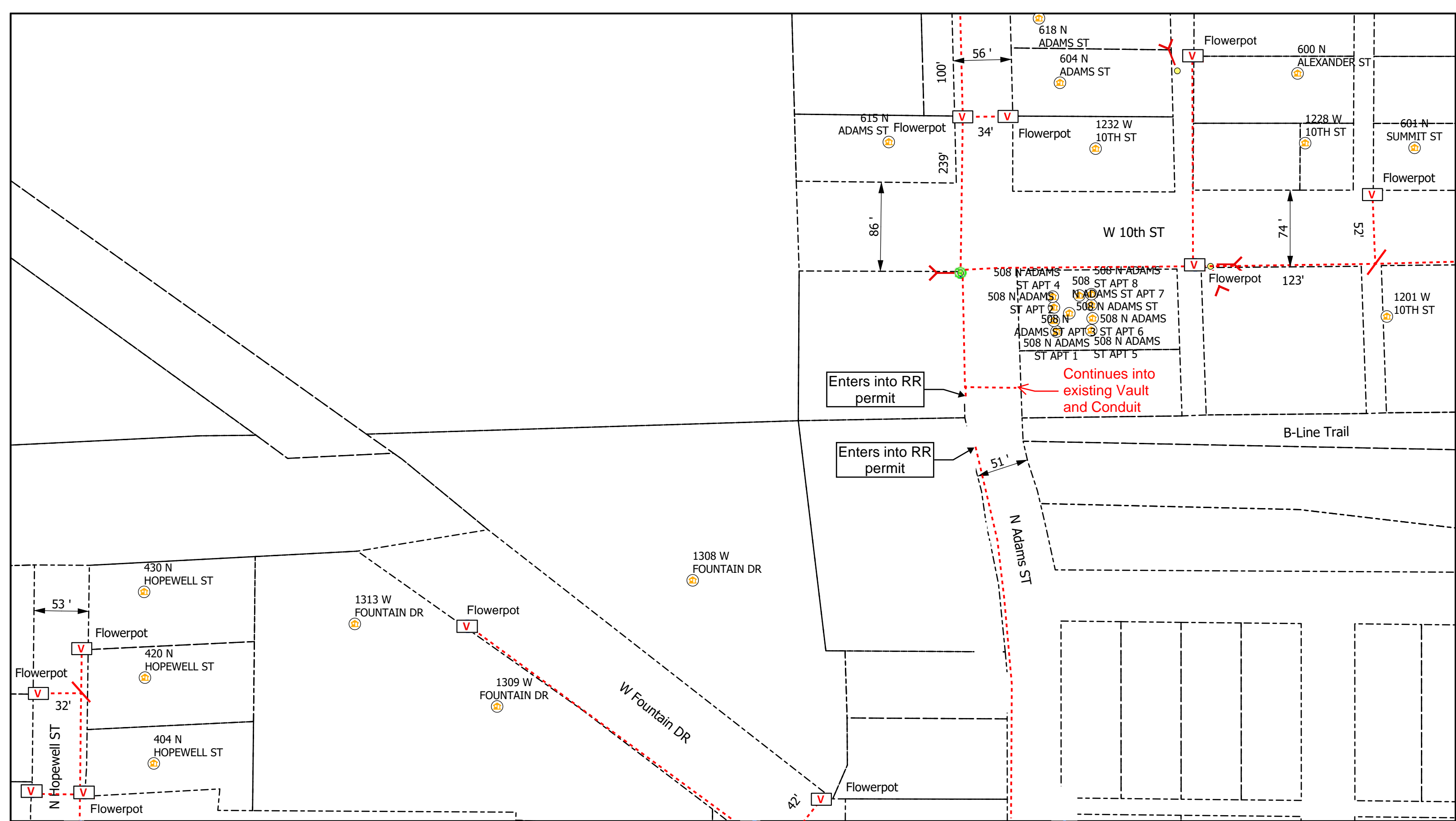

Legend

- Poles
- V Vaults
- Overhead Strand
- - - Conduit
- Bloomington_Parcels
- Ⓜ Risers
- Ⓜ Address
- Y Anchor
- ← Sidewalk
- Grids

All Flowerpots 12" DIA



City of Bloomington, IN Permit:
Design View

INI	BY	DATE	DESCRIPTION



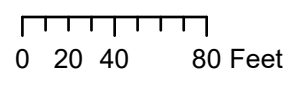
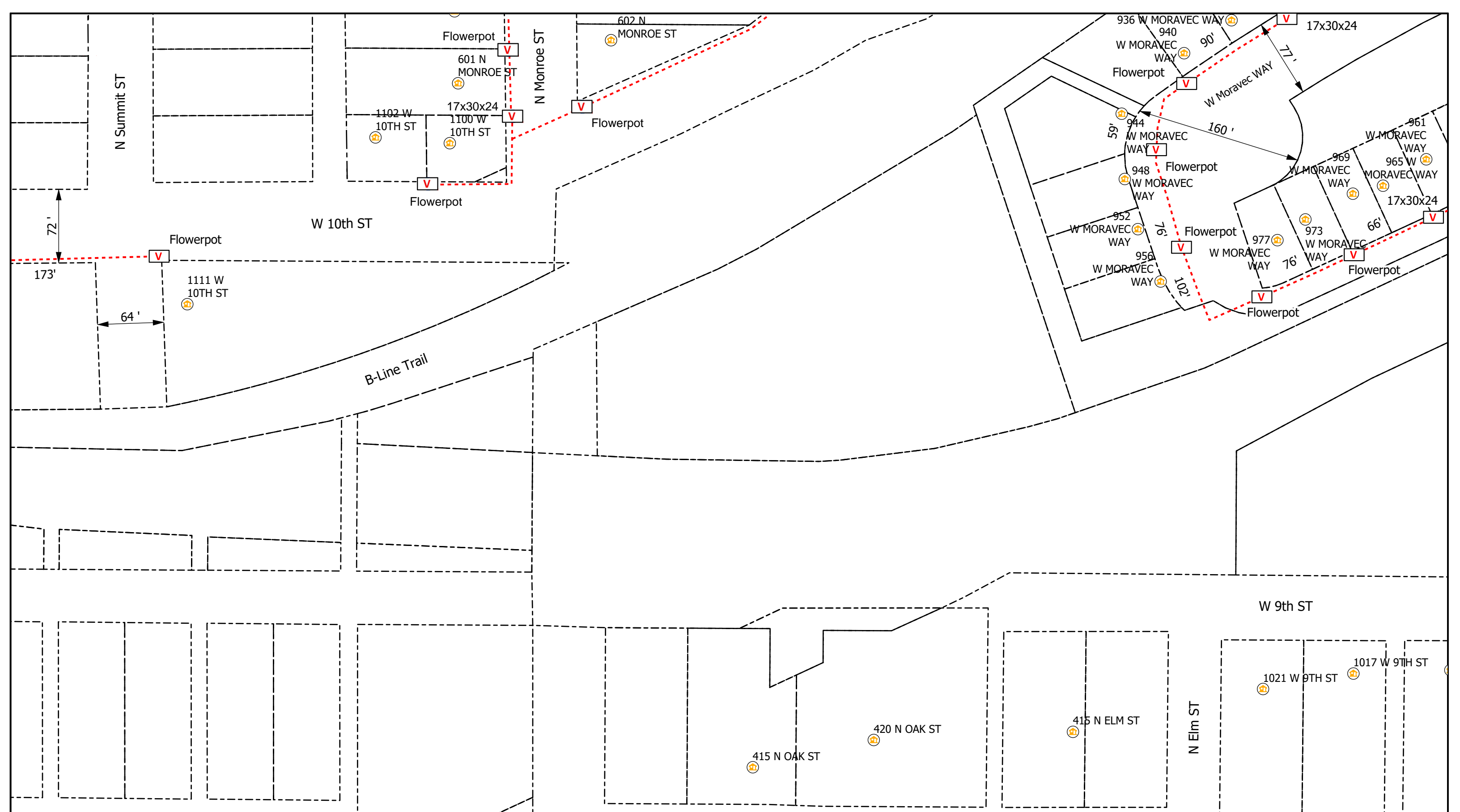

Legend

- Poles
- V Vaults
- Overhead Strand
- - - Conduit
- Bloomington_Parcels
- Ⓜ Risers
- Ⓜ Address
- Y Anchor
- ← Sidewalk
- Grids

All Flowerpots 12" DIA



City of Bloomington, IN Permit:
Design View

INI	BY	DATE	DESCRIPTION



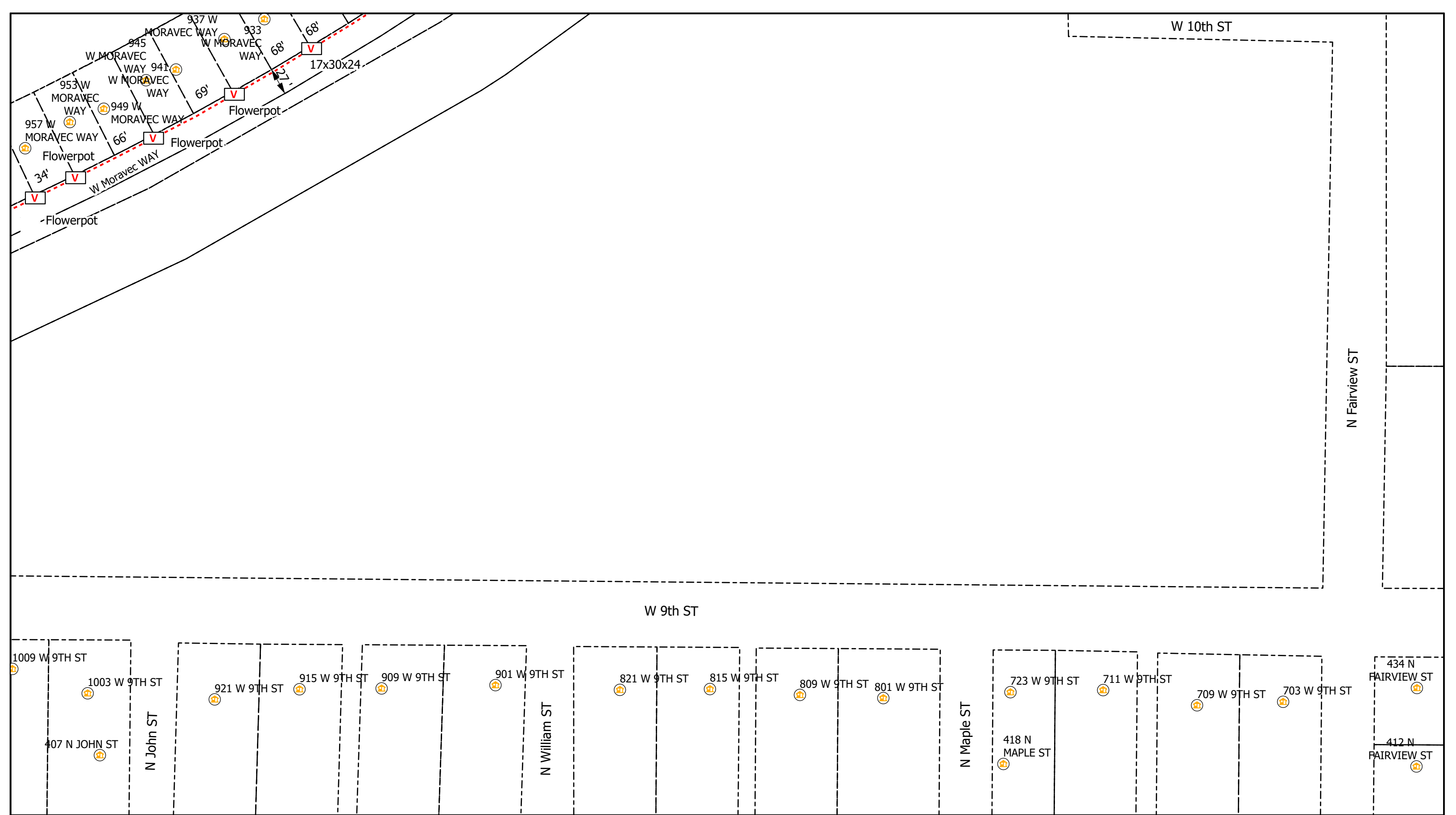

0 20 40 80 Feet

Legend

- Poles
- V Vaults
- Overhead Strand
- Conduit
- Bloomington_Parcels
- R Risers
- Ⓜ Address
- Y Anchor
- ← Sidewalk
- Grids

All Flowerpots 12" DIA



City of Bloomington, IN Permit:
Design View

INI	BY	DATE	DESCRIPTION



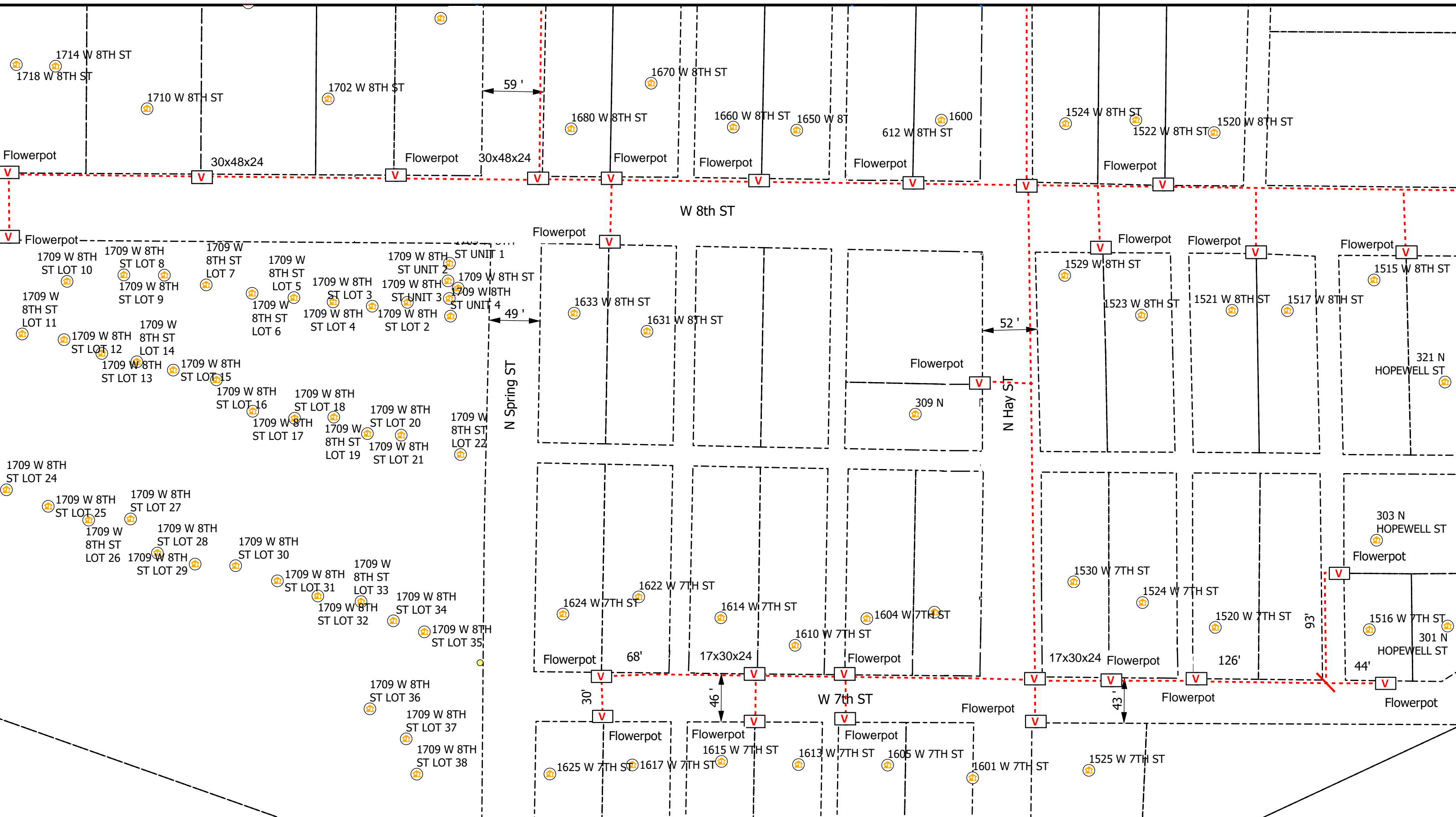

Legend

- Poles
- V Vaults
- Overhead Strand
- Conduit
- Bloomington_Parcels
- R Risers
- A Address
- Y Anchor
- ← Sidewalk
- Grids

All Flowerpots 12" DIA

N

City of Bloomington, IN Permit:
Design View

INI	BY	DATE	DESCRIPTION

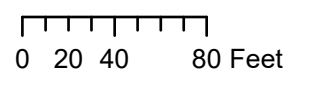
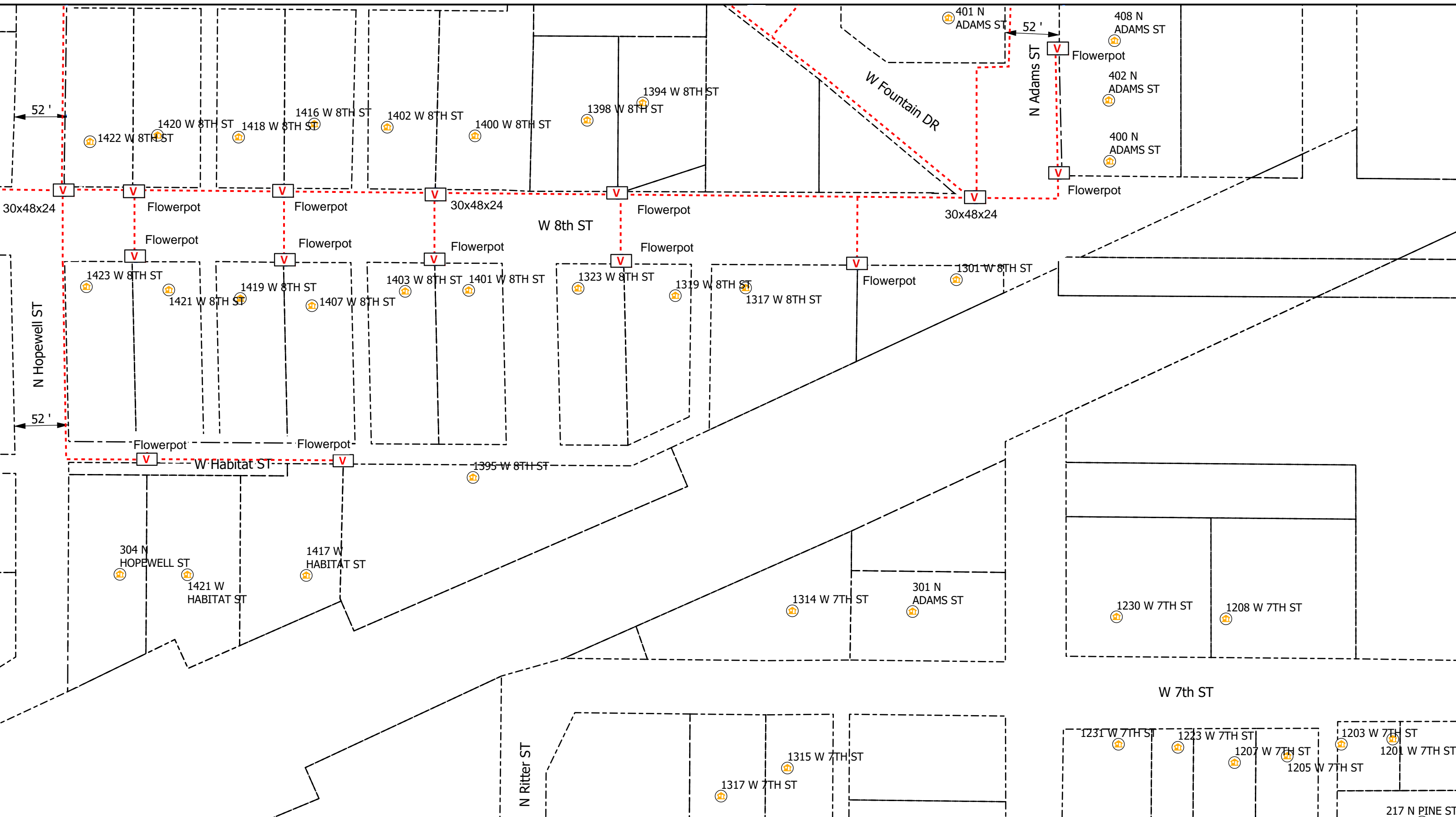

Legend

- Poles
- Vaults
- Overhead Strand
- Conduit
- Bloomington_Parcels
- Risers
- Address
- Anchor
- Sidewalk
- Grids

All Flowerpots 12" DIA



City of Bloomington, IN Permit:
Design View

INI	BY	DATE	DESCRIPTION



Carlton® PV-Mold® Nonmetallic Pole Riser System

Carlton PV-Mold is a nonmetallic pole riser system designed to protect communications power cable installed on poles.

Features:

- Meets or exceeds requirements outlined in the National Electric Safety Code (NESC).
- Designed in accordance with NEMA TC-19 specifications.
- Ultraviolet, cold temperature and corrosive atmosphere resistant.
- Schedule 40 wall meets Schedule 80 PVC conduit impact requirements per NEMA TC-19.
- No grounding required.
- Belled end fits over each added section or conduit.
- Flame retardant.
- Requires no maintenance.
- PV-Mold acts as an insulator against electrical shock.
- Interchangeable parts and accessories to match the needs of specific requirements.



Steel U-Guard requires grounding strapping and does not have belled ends.



PV-Mold has belled ends, flanged design and does not require grounding.

Flanged Overall Length 10 Feet, Including Bell

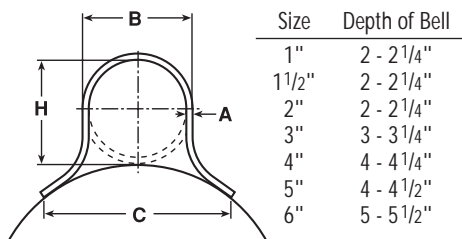

Slots are 1/2" from side to side, and allow for expansion and contraction.

Slot Dimensions: for sizes 2" through 6" are 5/16" wide, 3/4" long.

Slot Dimensions: for 1" and 1 1/2" are 3/16" wide, 3/4" long.

Slot Spacing: 18" from center, beginning 6" from end.



Standard Duty

Part No.	Size	Std. Ctn. Qty.	Std. Ctn. Wt. (lbs.)	Dimensions				Actual Impact @ 0°C 20 Pound Top
				A	B	C	H	
59208N	1"	294	1059	0.100"	1 5/8"	2 3/8"	1 5/8"	40 Ft.-Lbs.
59211N	2"	136	726	0.100"	2 3/8"	4 1/2"	2 3/8"	100 Ft.-Lbs.
59211X (5' length)	2"	136	363	0.100"	2 3/8"	4 1/2"	2 3/8"	100 Ft.-Lbs.
59213N	3"	66	761	0.150"	3 1/2"	6"	3 1/2"	110 Ft.-Lbs.
59213X (5' length)	3"	66	381	0.150"	3 1/2"	6"	3 1/2"	100 Ft.-Lbs.
59215N	4"	65	910	0.150"	4 1/2"	6 1/2"	4 1/2"	110 Ft.-Lbs.
59216N	5"	30	515	0.150"	5 1/2"	7 1/2"	5 1/2"	110 Ft.-Lbs.

Heavy Duty Schedule 40

59010N	1 1/2"	200	1142	0.145"	1 29/32"	3 1/2"	1 29/32"	100 Ft.-Lbs.
59011N	2"	136	1214	0.154"	2 3/8"	4 1/2"	2 3/8"	150 Ft.-Lbs.
59013N	3"	66	937	0.216"	3 1/2"	6"	3 9/32"	150 Ft.-Lbs.
59015N	4"	65	1621	0.237"	4 1/2"	6 1/2"	4 1/2"	260 Ft.-Lbs.
59015X (5' length)	4"	65	707	0.237"	4 1/2"	6 1/2"	4 1/2"	260 Ft.-Lbs.
59016N	5"	30	870	0.258"	5 1/2"	7 1/2"	5 1/2"	260 Ft.-Lbs.
59017N	6"	30	1160	0.280"	6 5/8"	8 3/4"	6 5/8"	260 Ft.-Lbs.

Extra Heavy Duty Schedule 80

59411N	2"	136	1549	0.218"	2 3/8"	4 1/2"	2 3/8"	300 Ft.-Lbs.
59413N	3"	66	1495	0.030"	3 1/2"	6"	3 1/2"	525 Ft.-Lbs.

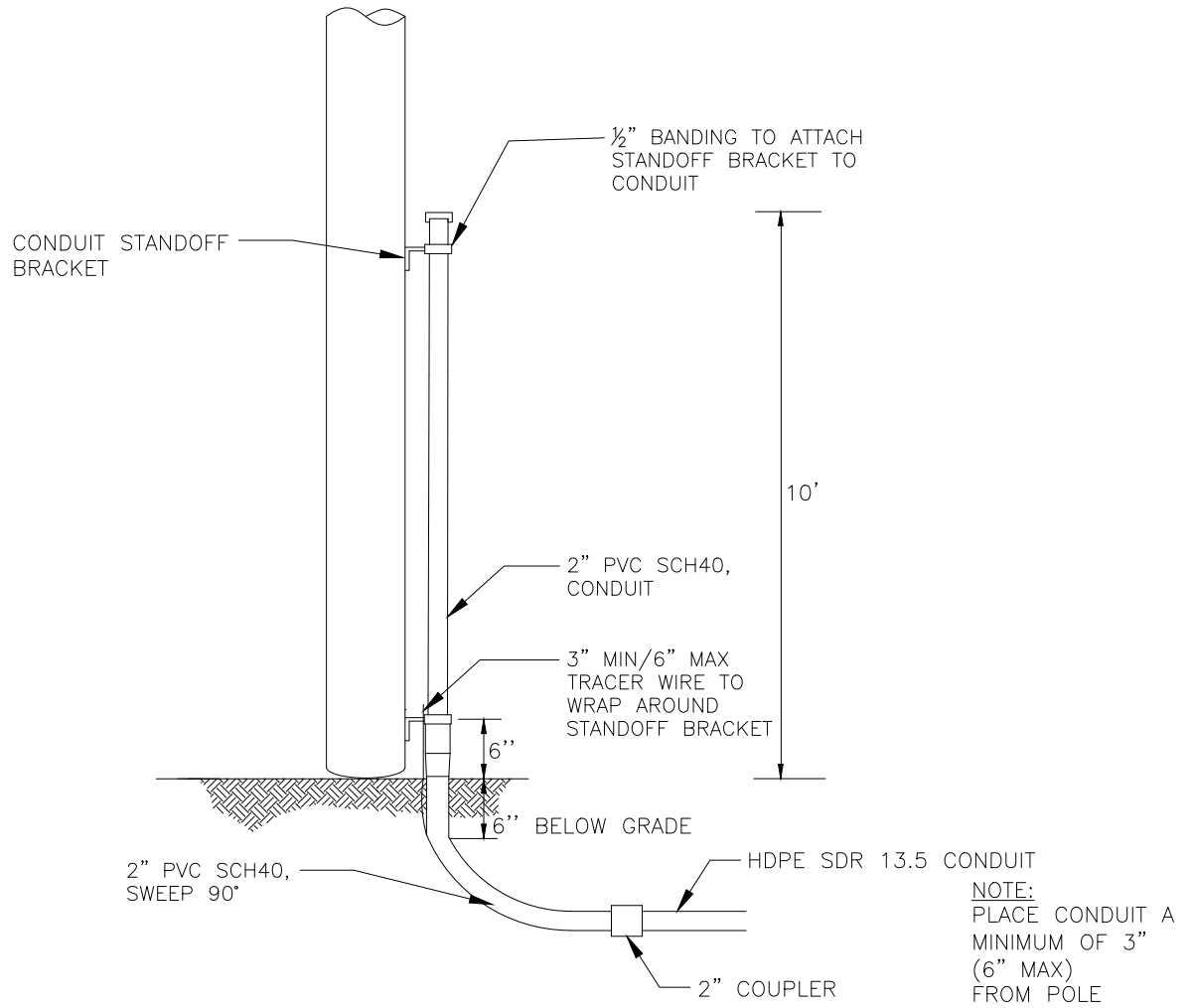

DESCRIPTION	QTY	MANUFACTURER (PREFERRED)	PART #
SCREW, LAG, 1/2" x 4-1/2"	10		
HDPE SDR 13.5 CONDUIT, VARIOUS SIZES	N/A		
2" PVC SCH40, RISER PIPE	1		
#12 TRACER WIRE	N/A		
2" PVC SCH40, SWEEP, 90 DEG	1		
CONDUIT STANDOFF BRACKET	VARIES		
CONDUIT STRAP KIT	VARIES		
2" COUPLER	1		



TYPICAL RISER
CONDUIT
WOOD POLE

(R2-W)

CONCEPTUAL SIDE VIEW

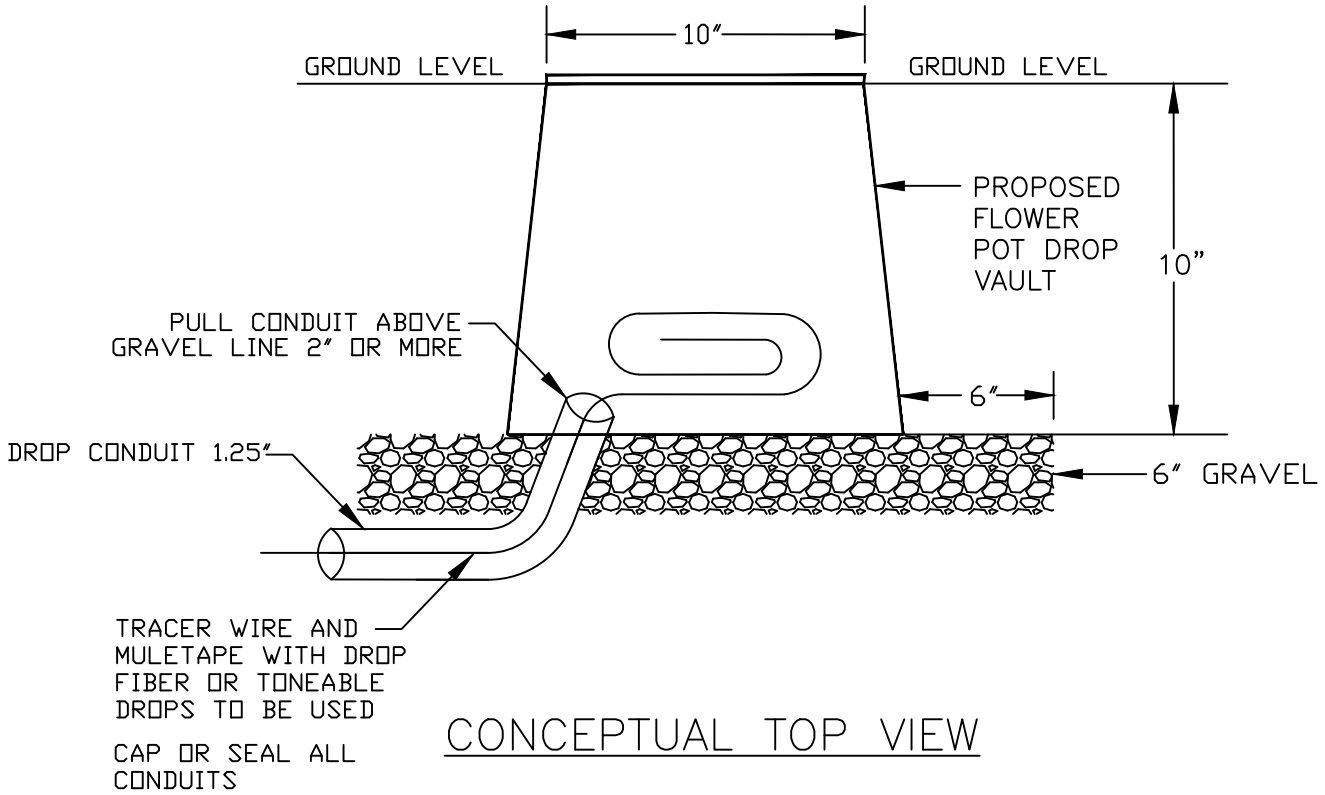

CONCEPTUAL TOP VIEW

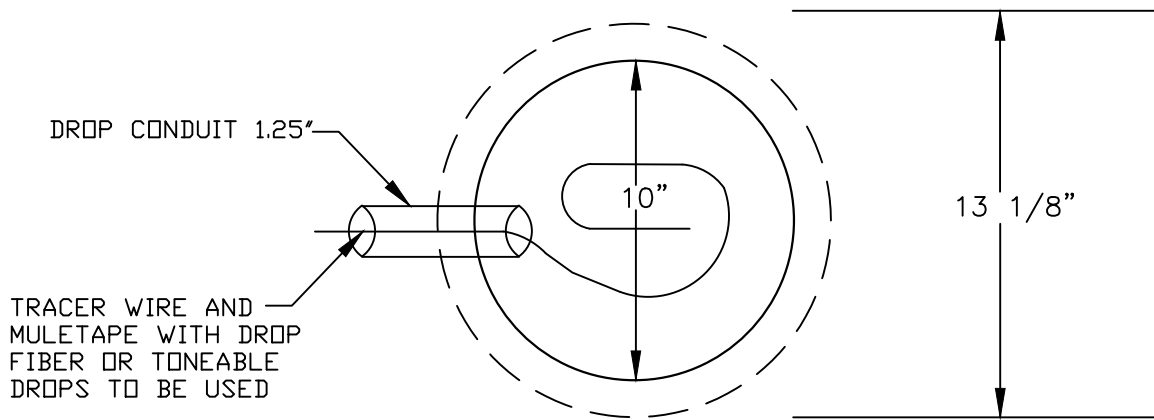

FLOWER POT

30"x48" PC UNIT, 2PC TIER 15/22
 18", 24", and 36" HEIGHT



AMERICAN POLYMER COMPANY

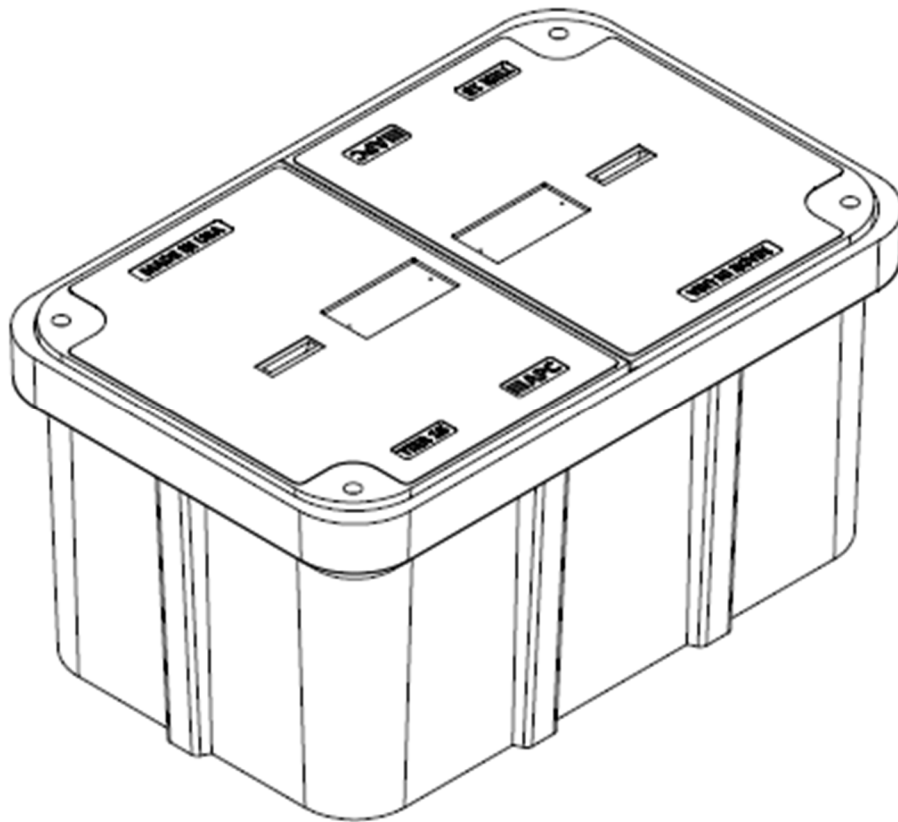

Description	Nominal Size	ANSI Tier	Part Number	Estimated Weight
PC Unit – TIER 15	30"x48"x18"	Tier 15	P304818HU15...	460 lbs.
PC Unit – TIER 22	30"x48"x18"	Tier 22	P304818HU22...	525 lbs.
PC Unit – TIER 15	30"x48"x24"	Tier 15	P304824HU15...	510 lbs.
PC Unit – TIER 22	30"x48"x24"	Tier 22	P304824HU22...	575 lbs.
PC Unit – TIER 15	30"x48"x36"	Tier 15	P304836HU15...	615 lbs.
PC Unit – TIER 22	30"x48"x36"	Tier 22	P304836HU22...	680 lbs.



30"x48" PC UNIT, 2PC TIER 15/22

18", 24", and 36" HEIGHT



AMERICAN POLYMER COMPANY

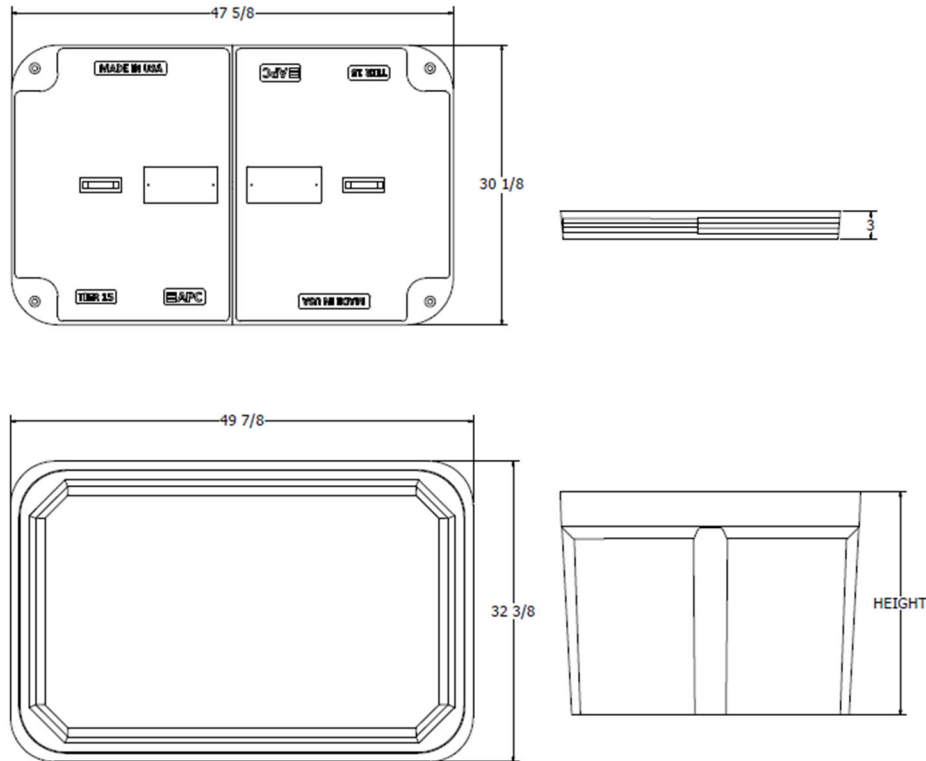

Components	Nominal Size	ANSI Tier	Part Number	Estimated Weight
Replacement Box	30"x48"x18"	Tier 22	P304818B22	185 lbs.
Replacement Box	30"x48"x24"	Tier 22	P304824B22	235 lbs.
Replacement Box	30"x48"x36"	Tier 22	P304836B22	340 lbs.
Replacement Lids - T15	30"x48" (half)	Tier 15	Various	150 lbs.
Replacement Lids - T22	30"x48" (half)	Tier 22	Various	170 lbs.

Bolt options



Machine Thread



Auger Thread



24"x36" PC UNIT, TIER 15/22
 18", 24", 30", and 36" HEIGHT



AMERICAN POLYMER COMPANY

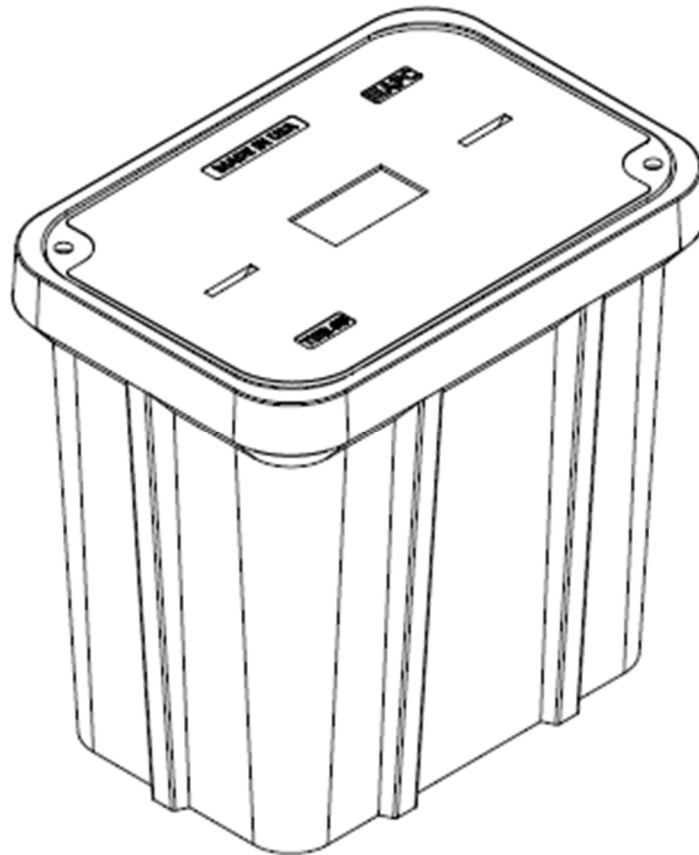

Description	Nominal Size	ANSI Tier	Part Number	Estimated Weight
PC Unit – TIER 15	24x36"x18"	Tier 15	P243618U15...	335 lbs.
PC Unit – TIER 22	24x36"x18"	Tier 22	P243618U22...	355 lbs.
PC Unit – TIER 15	24x36"x24"	Tier 15	P243624U15...	365 lbs.
PC Unit – TIER 22	24x36"x24"	Tier 22	P243624U22...	385 lbs.
PC Unit – TIER 15	24x36"x30"	Tier 15	P243630U15...	395 lbs.
PC Unit – TIER 22	24x36"x30"	Tier 22	P243630U22...	415 lbs.
PC Unit – TIER 15	24x36"x36"	Tier 15	P243636U15...	425 lbs.
PC Unit – TIER 22	24x36"x36"	Tier 22	P243636U22...	445 lbs.



24"x36" PC UNIT, TIER 15/22

18", 24", 30", and 36" HEIGHT



AMERICAN POLYMER COMPANY

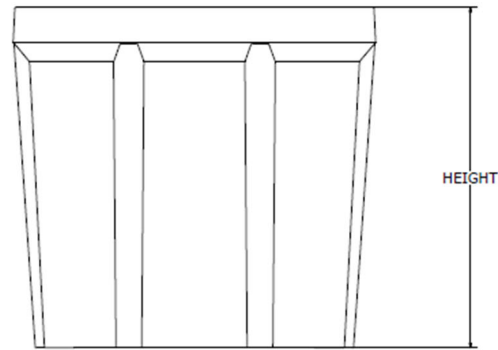
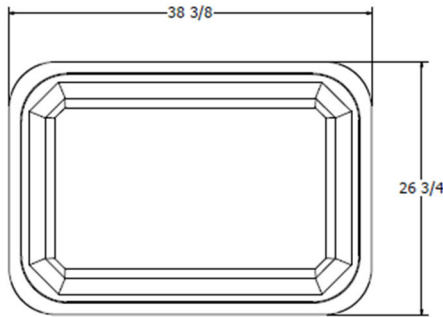
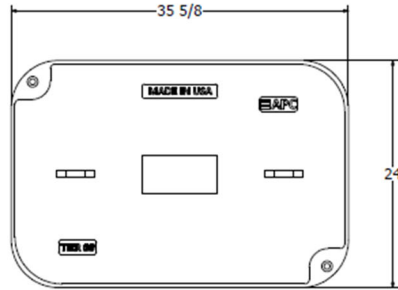

Components	Nominal Size	ANSI Tier	Part Number	Estimated Weight
Replacement Box	24"x36"x18"	Tier 22	P243618B22	165 lbs.
Replacement Box	24"x36"x24"	Tier 22	P243624B22	195 lbs.
Replacement Box	24"x36"x30"	Tier 22	P243630B22	225 lbs.
Replacement Box	24"x36"x36"	Tier 22	P243636B22	255 lbs.
Replacement Lids - T15	24"x36"	Tier 15	Various	170 lbs.
Replacement Lids - T22	24"x36"	Tier 22	Various	190 lbs.

Bolt options

Hex Head



Machine Thread



Penta Head



Auger Thread



17"x30" PC UNIT, TIER 15/22

12", 18", 24", and 30" HEIGHT



AMERICAN POLYMER COMPANY

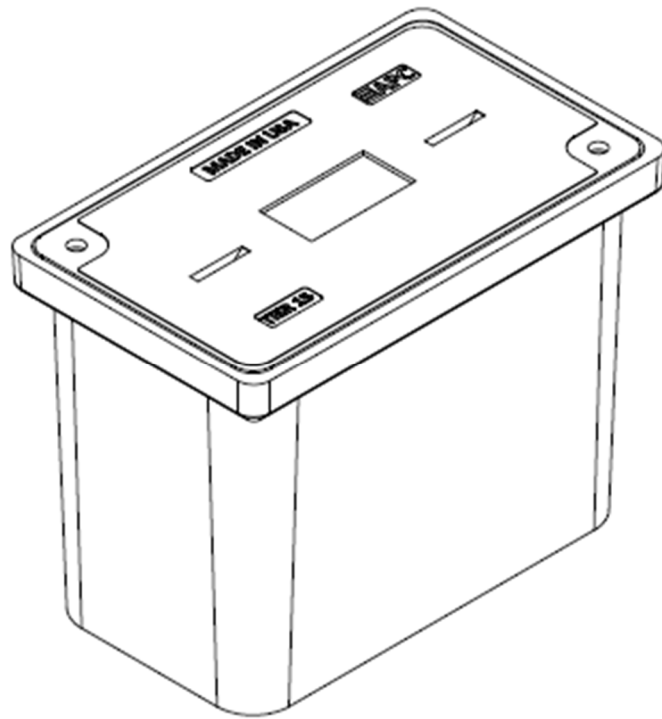

Description	Nominal Size	ANSI Tier	Part Number	Estimated Weight
PC Unit – TIER 15	17"x30"x12"	Tier 15	P173012U15...	138 lbs.
PC Unit – TIER 22	17"x30"x12"	Tier 22	P173012U22...	147 lbs.
PC Unit – TIER 15	17"x30"x18"	Tier 15	P173018U15...	172 lbs.
PC Unit – TIER 22	17"x30"x18"	Tier 22	P173018U22...	181 lbs.
PC Unit – TIER 15	17"x30"x24"	Tier 15	P173024U15...	192 lbs.
PC Unit – TIER 22	17"x30"x24"	Tier 22	P173024U22...	201 lbs.
PC Unit – TIER 15	17"x30"x30"	Tier 15	P173030U15...	217 lbs.
PC Unit – TIER 22	17"x30"x30"	Tier 22	P173030U22...	226 lbs.



17"x30" PC UNIT, TIER 15/22

12", 18", 24", and 30" HEIGHT



AMERICAN POLYMER COMPANY

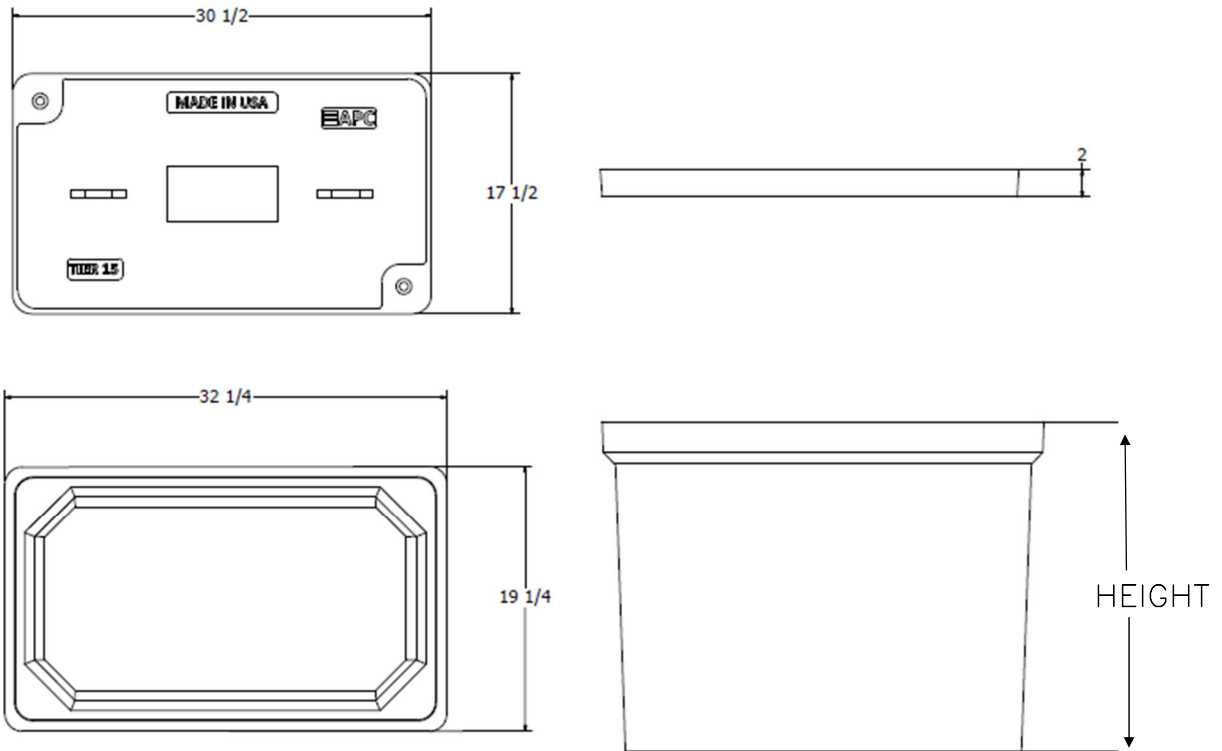

Components	Nominal Size	ANSI Tier	Part Number	Estimated Weight
Replacement Box	17"x30"X12"	Tier 22	P173012B22	66 lbs.
Replacement Box	17"x30"X18"	Tier 22	P173018B22	100 lbs.
Replacement Box	17"x30"x24"	Tier 22	P173024B22	120 lbs.
Replacement Box	17"x30"x30"	Tier 22	P173030B22	145 lbs.
Replacement Lids – T15	17"x30"	Tier 15	Various	72 lbs.
Replacement Lids – T22	17"x30"	Tier 22	Various	81 lbs.

Bolt options



Machine Thread



Auger Thread



33"x60" PC UNIT, 2PC TIER 15/22
36" HEIGHT



AMERICAN POLYMER COMPANY

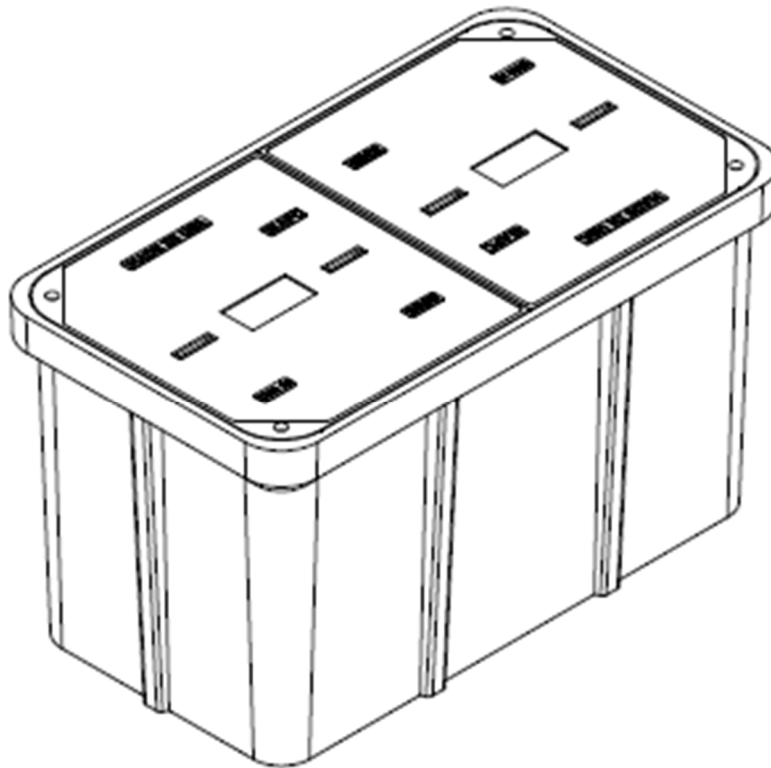

Description	Nominal Size	ANSI Tier	Part Number	Estimated Weight
PC Unit - TIER 15	33"x60"x36"	Tier 15	P336036U15...	930 lbs.
PC Unit - TIER 22	33"x60"x36"	Tier 22	P336036U22...	1030 lbs.



33"x60" PC UNIT, 2PC TIER 15/22

36" HEIGHT



AMERICAN POLYMER COMPANY

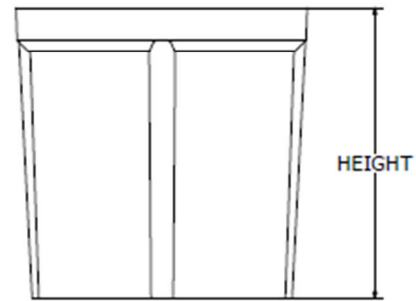
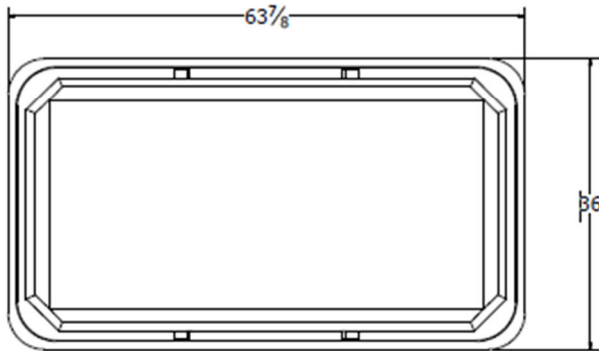
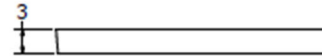
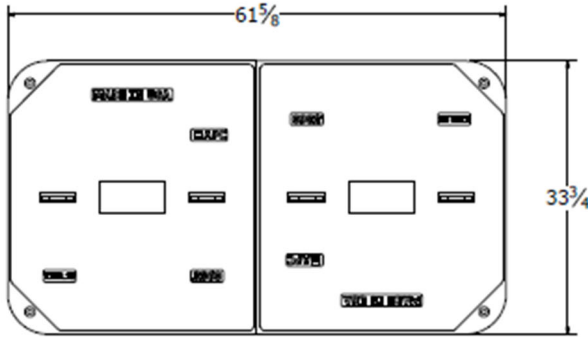

Components	Nominal Size	ANSI Tier	Part Number	Estimated Weight
Replacement Box	33"x60"x36"	Tier 22	P336036B22	530 lbs.
Replacement Lids - T15	33"x60" (half)	Tier 15	Various	200 lbs.
Replacement Lids - T22	33"x60" (half)	Tier 22	Various	250 lbs.

Bolt options

Hex Head



Machine Thread



Penta Head



Auger Thread



Speed (MPH) Prior To Road Work	SIGN SPACING, FT.		Must be Approved by an Engineer				
	BUFFER SPACE, FT.		Length	TAPER LENGTH, FT.		CHANNELIZING SPACING, FT.	
	Non-Divided Highways	Divided Highways		Shoulder (10 ft. Width)	Lane (12 ft. Width)	Through Taper	Through Buffer/Work Area
0-35	200	200	250	70	245	35	50
40-45	350	500	360	150	540	40	80
50-55	500	1000	495	185	660	50	100
60-70	SA-1000, SB-1500, SC-2640		730	235	840	60	120
Urban Low Speed - 100 FT							

APPROVED/ACCEPTED BY:
ENGINEER, OWNER, or PRIME CONTRACTOR
 Check for Notice to Proceed.
BLN01b-F12_N Hay St-TCP1

Signature: _____

Company: _____

Date: 3/8/2023 Project: BLN01b-F12_N Hay St-TCP1 :
: Traffic Control Suggestion For: AEG :
By: Road Runner Safety Services, Inc. : Nathan

Comments:
Drawing not to scale. Traffic control plan must be approved by an engineer. This is a suggestion only. Road Runners Safety Services, Inc. has no liability for this suggested traffic control plan. Actual placement and spacing of all traffic control devices will depend on field conditions and must conform to MUTCD standards.

- Legend**
- ADA Barricade
 - Channelizer
 - Conduit
 - Flagger (Person)
 - Overhead Strand
 - Sign
 - Vault
 - Work Area

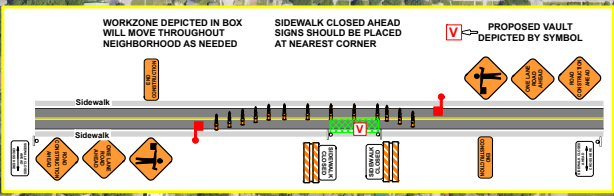

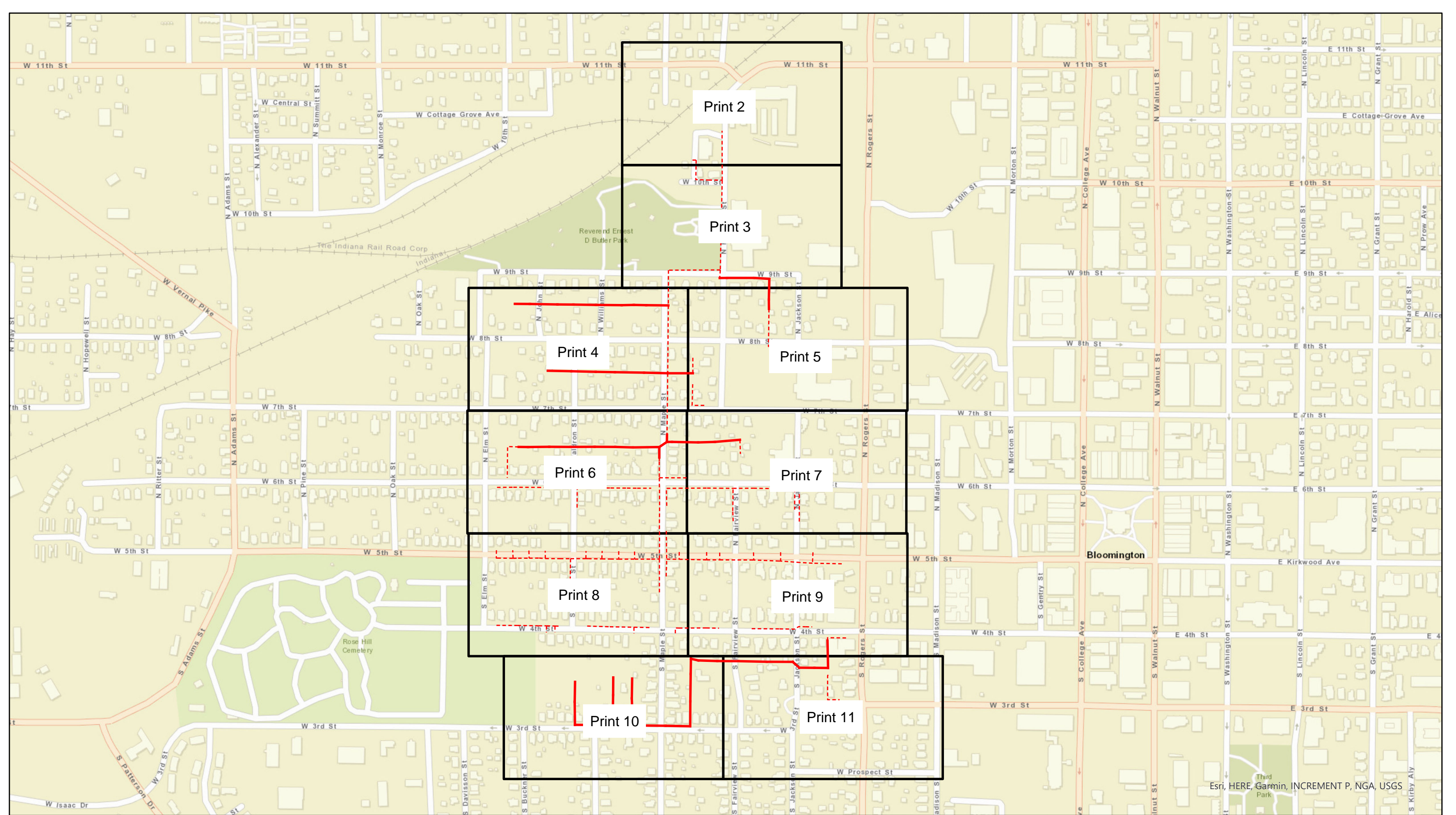

Legend BLN01b-F11_N Williams St

- Overhead Strand
- - - Conduit
- Grids

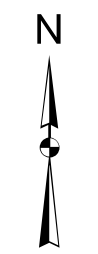

City of Bloomington, IN Permit:
Design View

INI	BY	DATE	DESCRIPTION

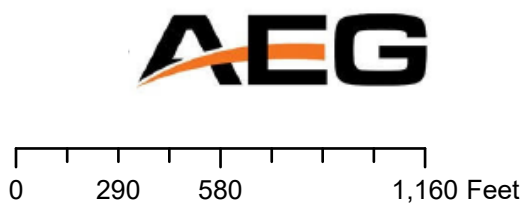

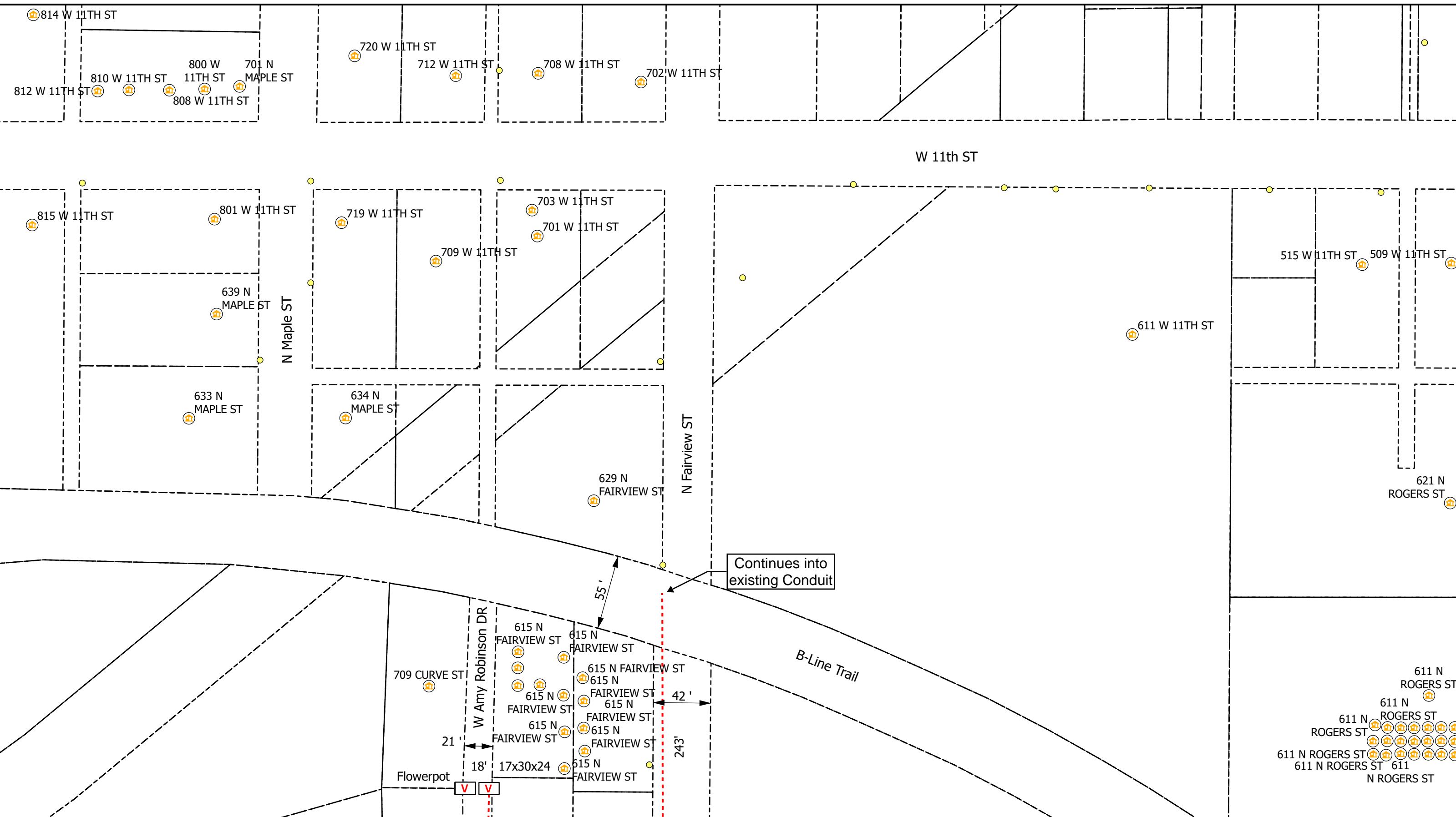

0 20 40 80 Feet

Legend

- Poles
- Vaults
- Overhead Strand
- Conduit
- Risers
- Address
- Anchor
- Sidewalk
- Bloomington_Parcels
- Grids

All Flowerpots 12" DIA

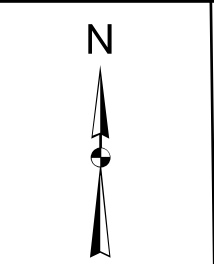

City of Bloomington, IN Permit:
Design View

INI	BY	DATE	DESCRIPTION

Print 2 of 11

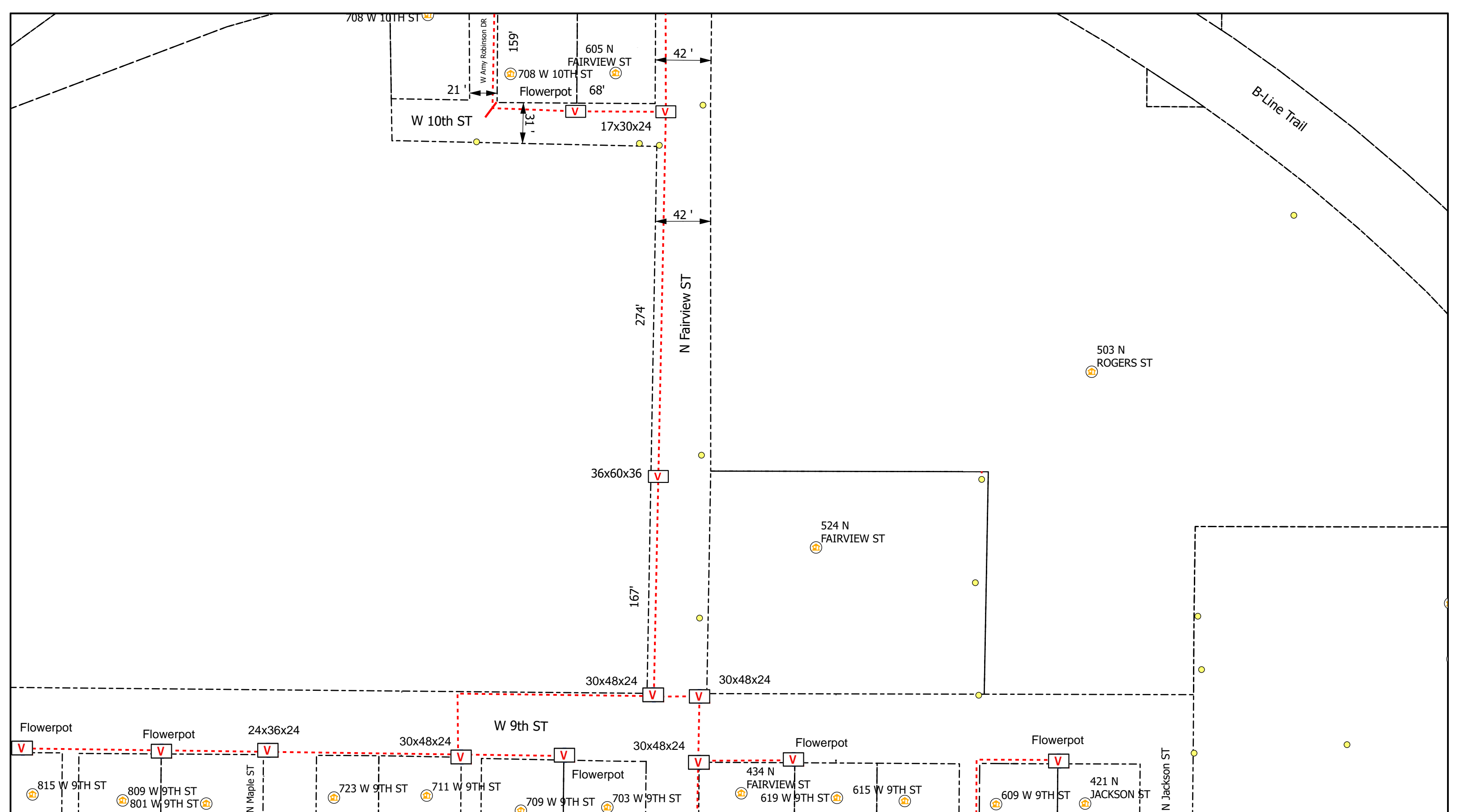

0 20 40 80 Feet

Legend

- Poles
- V Vaults
- Overhead Strand
- - - Conduit
- Ⓡ Risers
- Ⓜ Address
- Y Anchor
- ↖ Sidewalk
- Bloomington_Parcels
- Grids

All Flowerpots 12" DIA









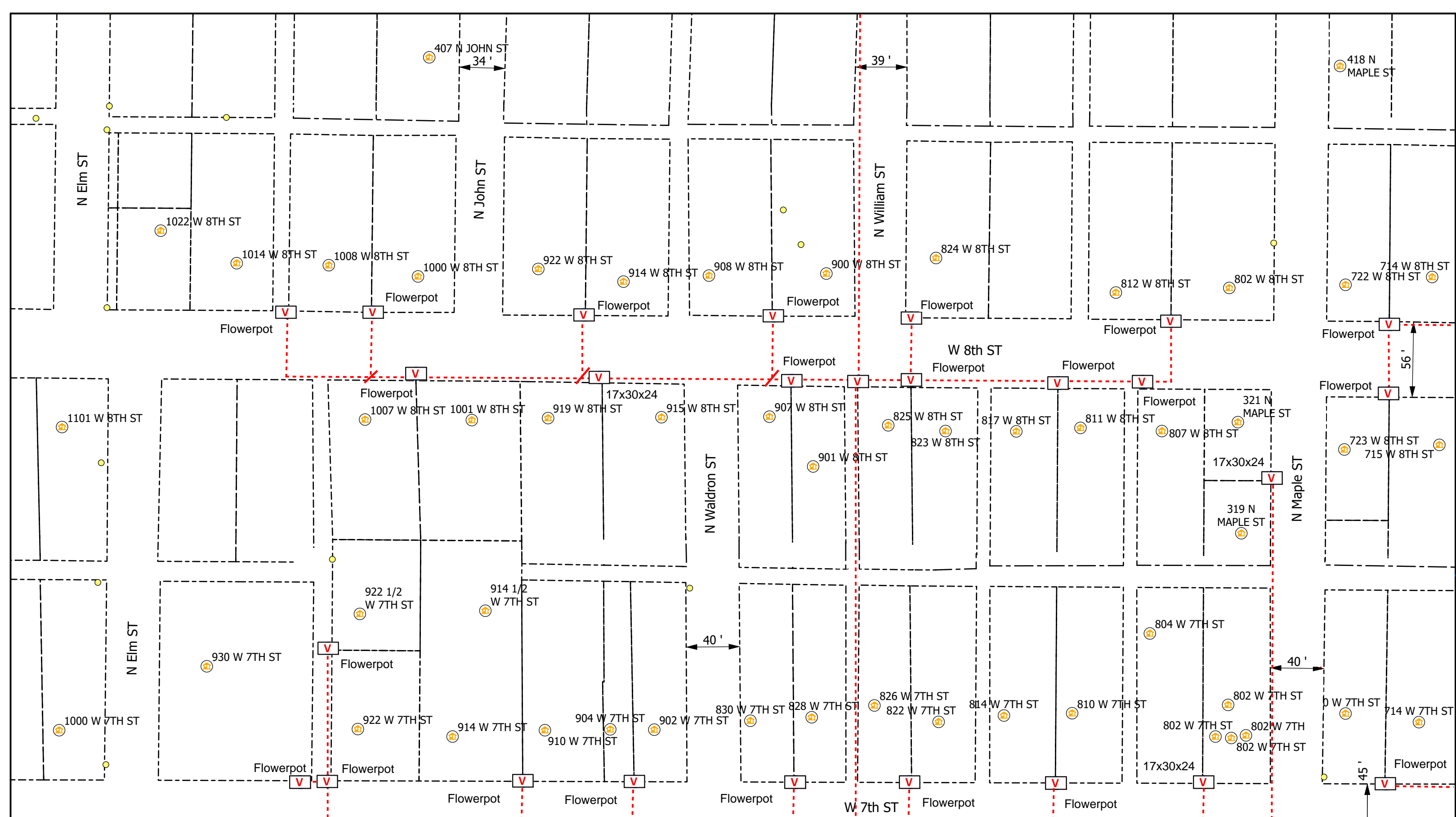



City of Bloomington, IN Permit:
Design View

INI	BY	DATE	DESCRIPTION





Legend

-  Poles
-  Risers
-  Sidewalk
-  Vaults
-  Address
-  Anchor
-  Overhead Strand
-  Conduit
-  Bloomington_Parcels
-  Grids

All Flowerpots 12" DIA



City of Bloomington, IN Permit:
Design View

INI	BY	DATE	DESCRIPTION



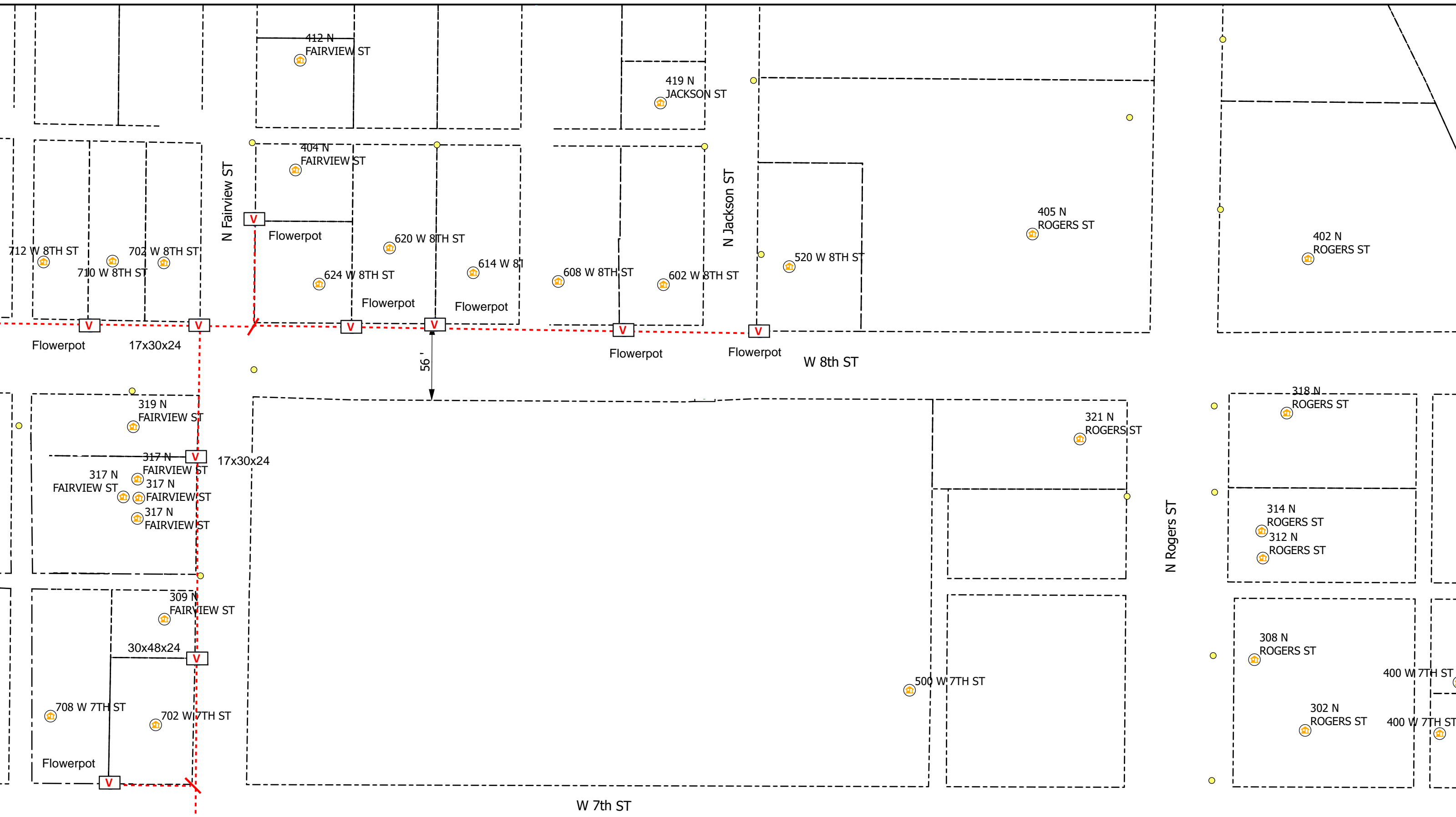

Legend

- Poles
- Risers
- Sidewalk
- Vaults
- Address
- Bloomington_Parcels
- Overhead Strand
- Anchor
- Conduit
- Grids

All Flowerpots 12" DIA

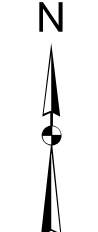

City of Bloomington, IN Permit:
Design View

INI	BY	DATE	DESCRIPTION



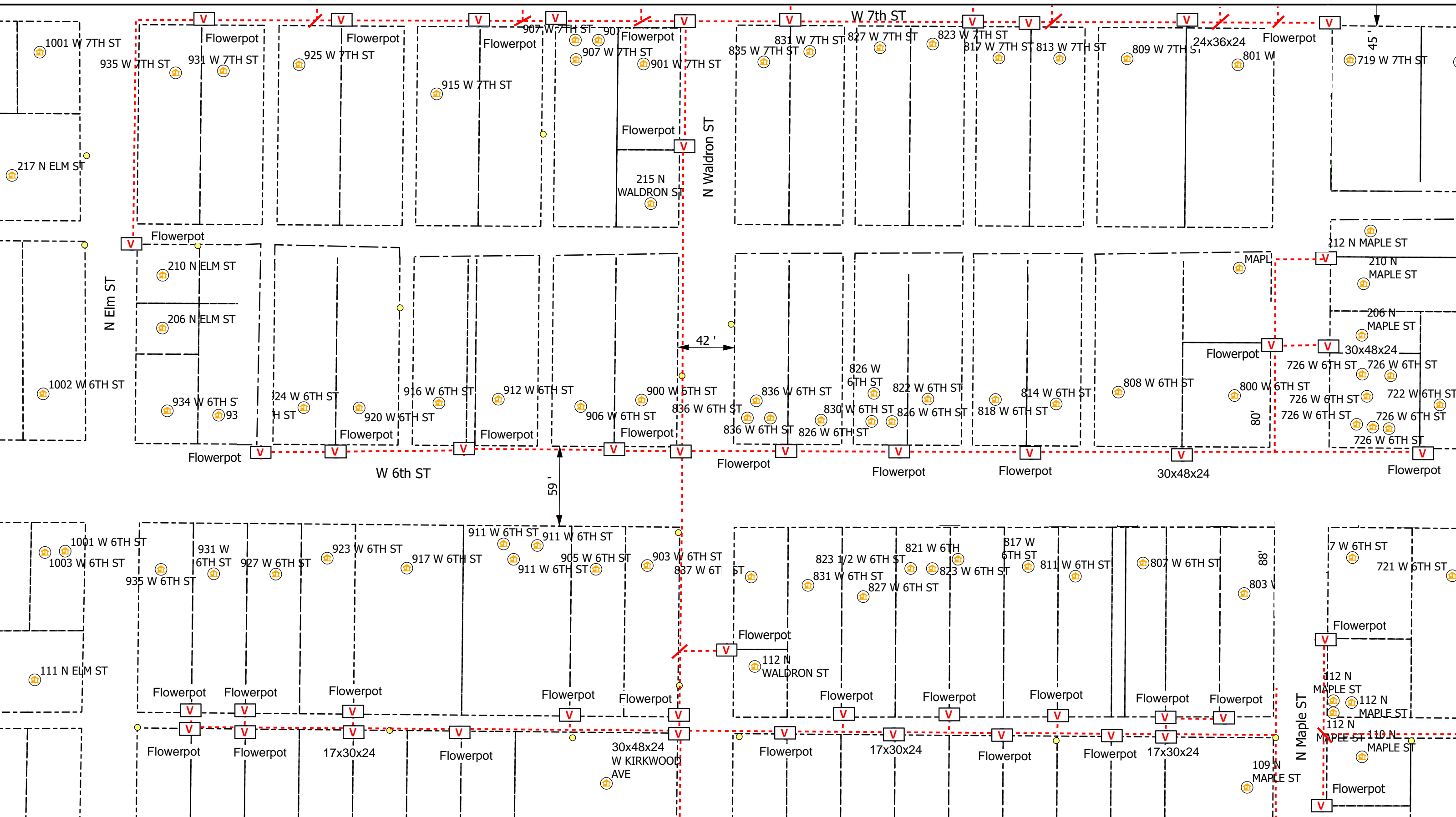

Legend

- Poles
- V Vaults
- Overhead Strand
- - - Conduit
- Ⓡ Risers
- Ⓜ Address
- Y Anchor
- ↖ Sidewalk
- Bloomington_Parcels
- Grids

All Flowerpots 12" DIA



City of Bloomington, IN Permit:
Design View

INI	BY	DATE	DESCRIPTION



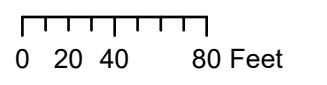
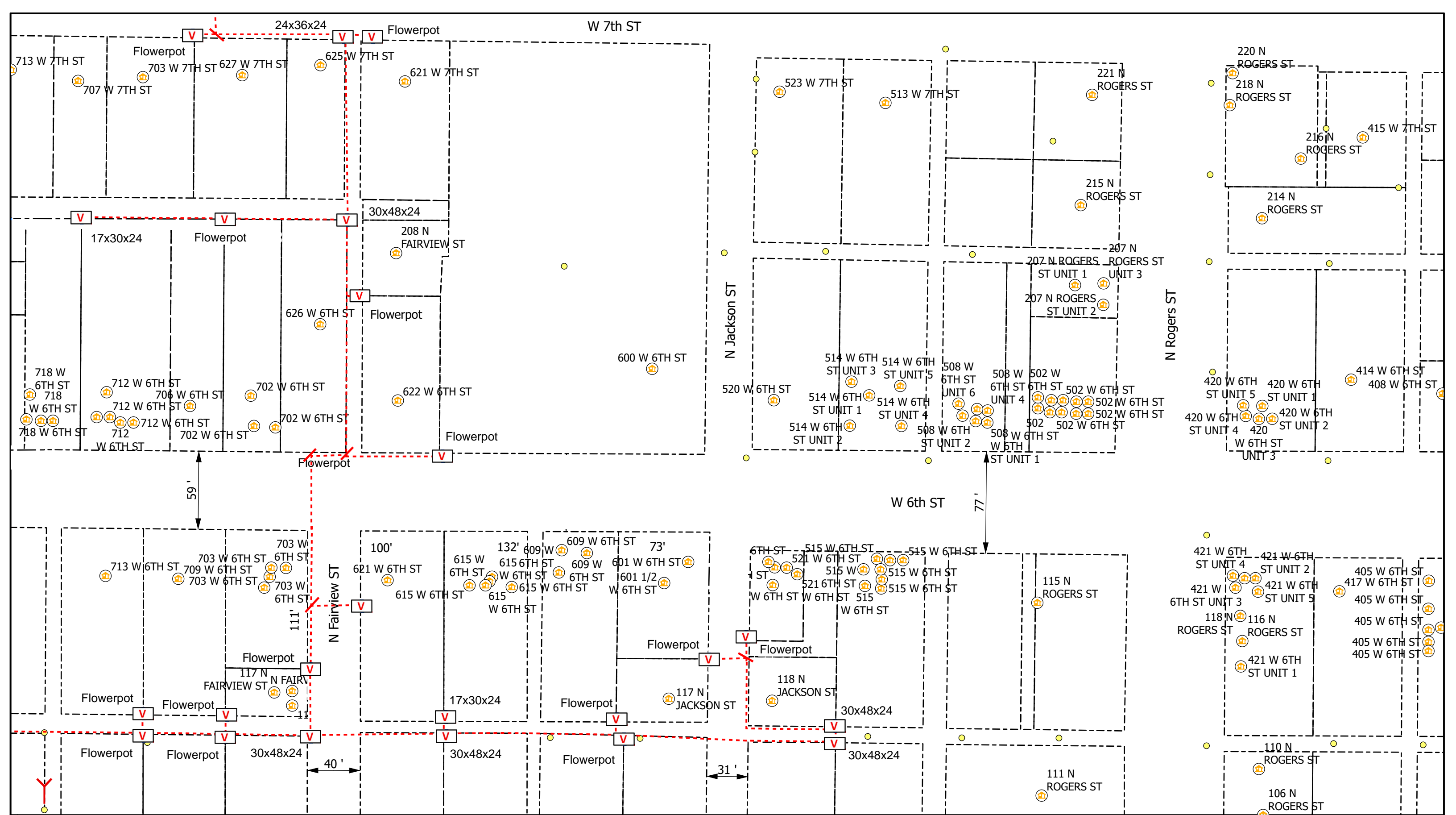

Legend

- Poles
- V Vaults
- Overhead Strand
- Conduit
- Ⓡ Risers
- Ⓜ Address
- Y Anchor
- ↖ Sidewalk
- Bloomington_Parcels
- Grids

All Flowerpots 12" DIA



City of Bloomington, IN Permit:
Design View

INI	BY	DATE	DESCRIPTION



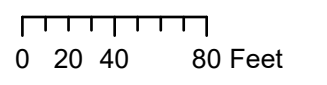
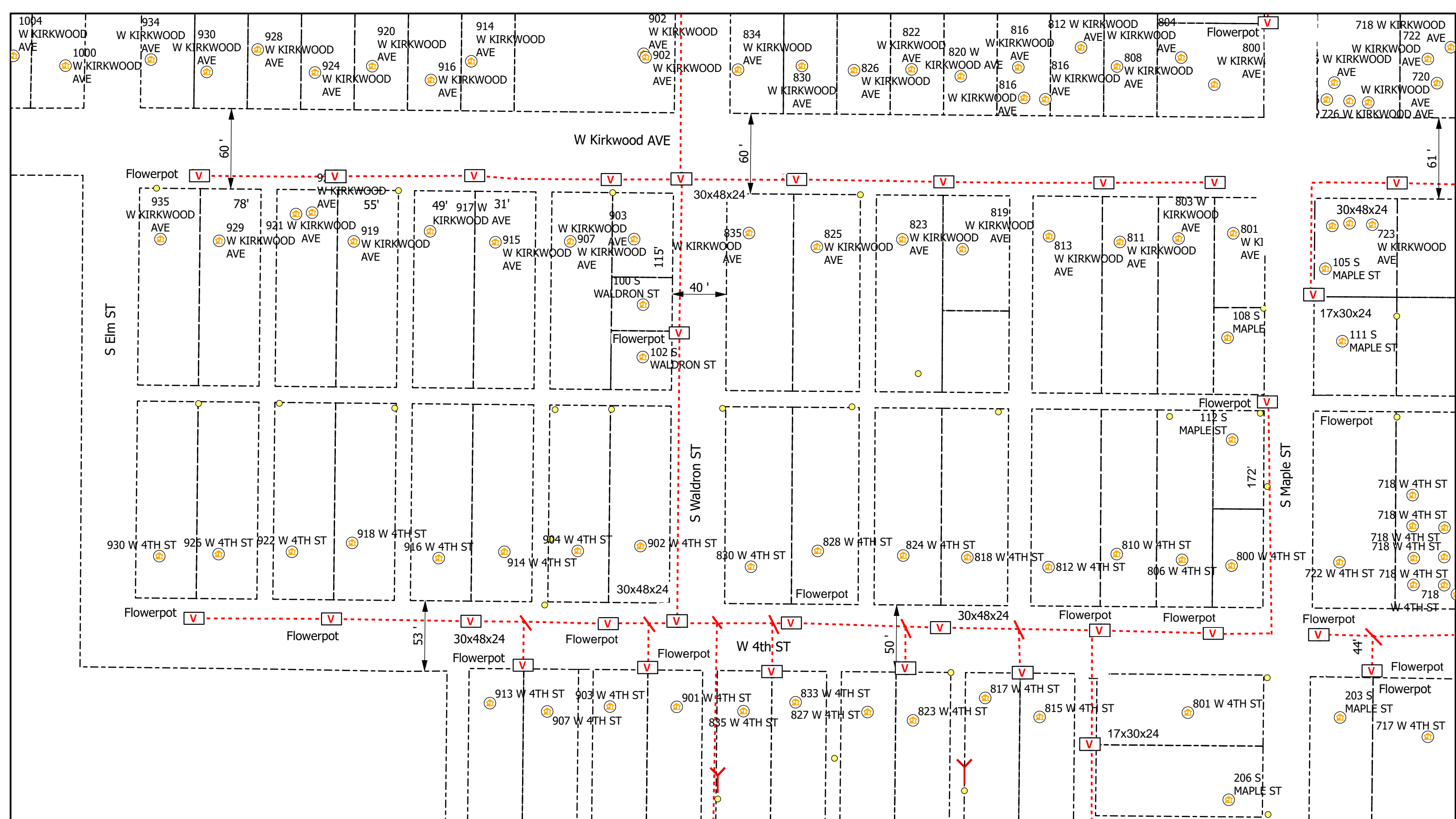

Legend

- Poles
- Ⓡ Risers
- Ⓜ Vaults
- Overhead Strand
- - - Conduit
- Ⓜ Address
- Y Anchor
- ↖ Sidewalk
- Bloomington_Parcels
- Grids

All Flowerpots 12" DIA



City of Bloomington, IN Permit:
Design View

INI	BY	DATE	DESCRIPTION



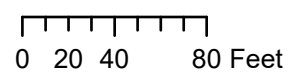
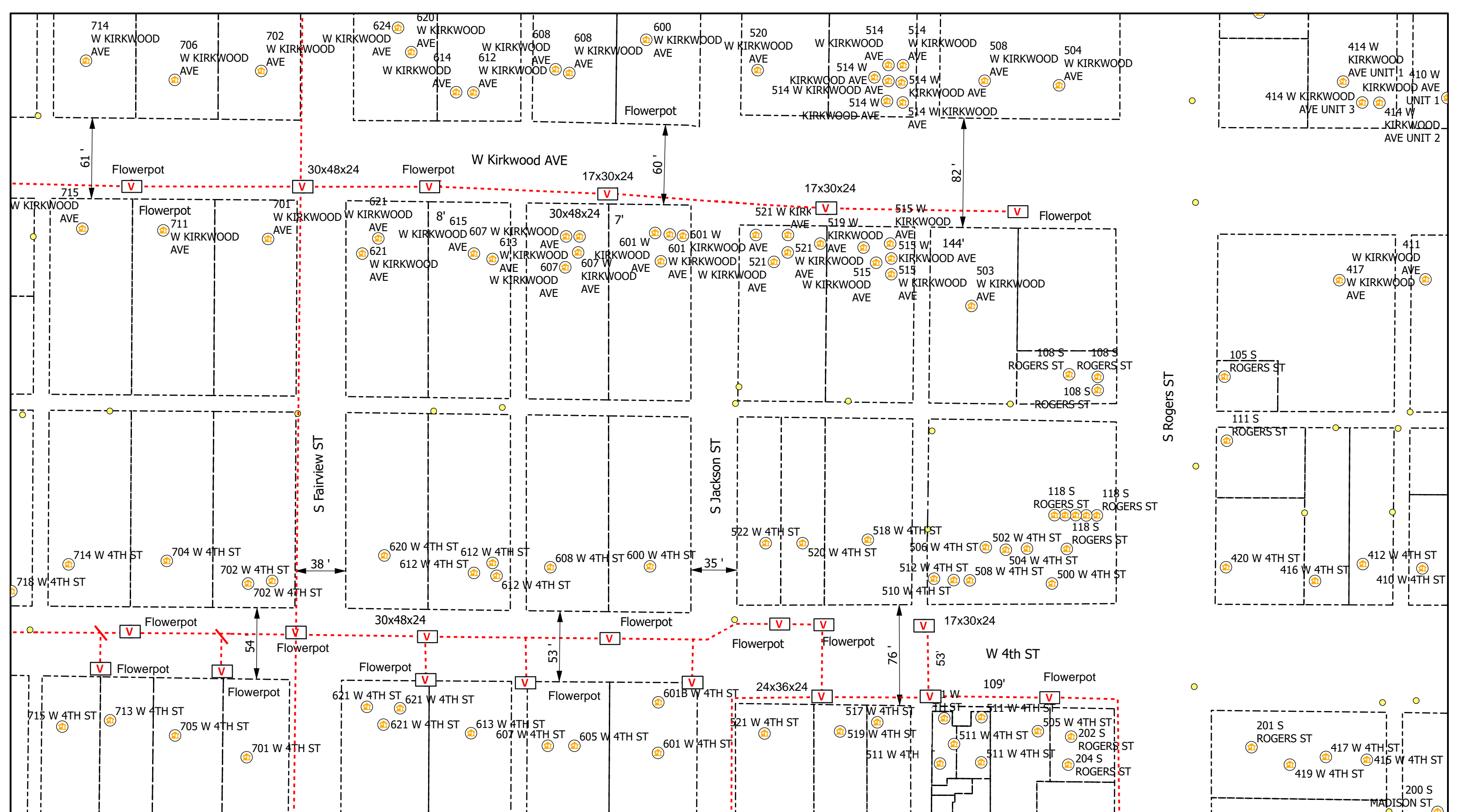

Legend

- Poles
- Vaults
- Overhead Strand
- Conduit
- Risers
- Address
- Anchor
- Sidewalk
- Bloomington_Parcels
- Grids

All Flowerpots 12" DIA



City of Bloomington, IN Permit:
Design View

INI	BY	DATE	DESCRIPTION



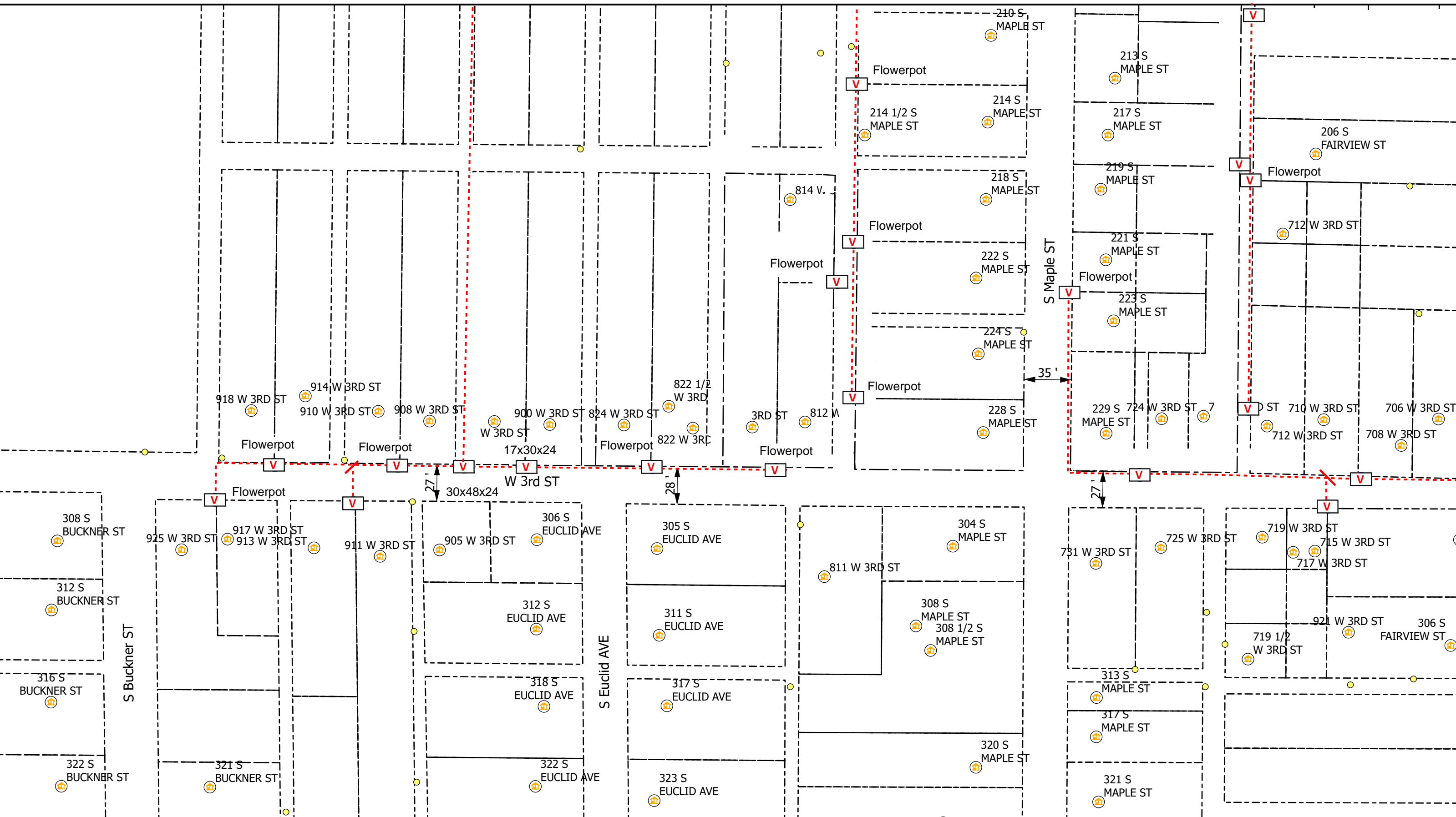

- Legend**
- Poles
 - Risers
 - Sidewalk
 - Vaults
 - Address
 - Bloomington_Parcels
 - Overhead Strand
 - Anchor
 - Grids
 - Conduit

All Flowerpots 12" DIA



City of Bloomington, IN Permit:
Design View

INI	BY	DATE	DESCRIPTION



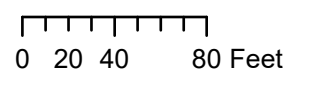
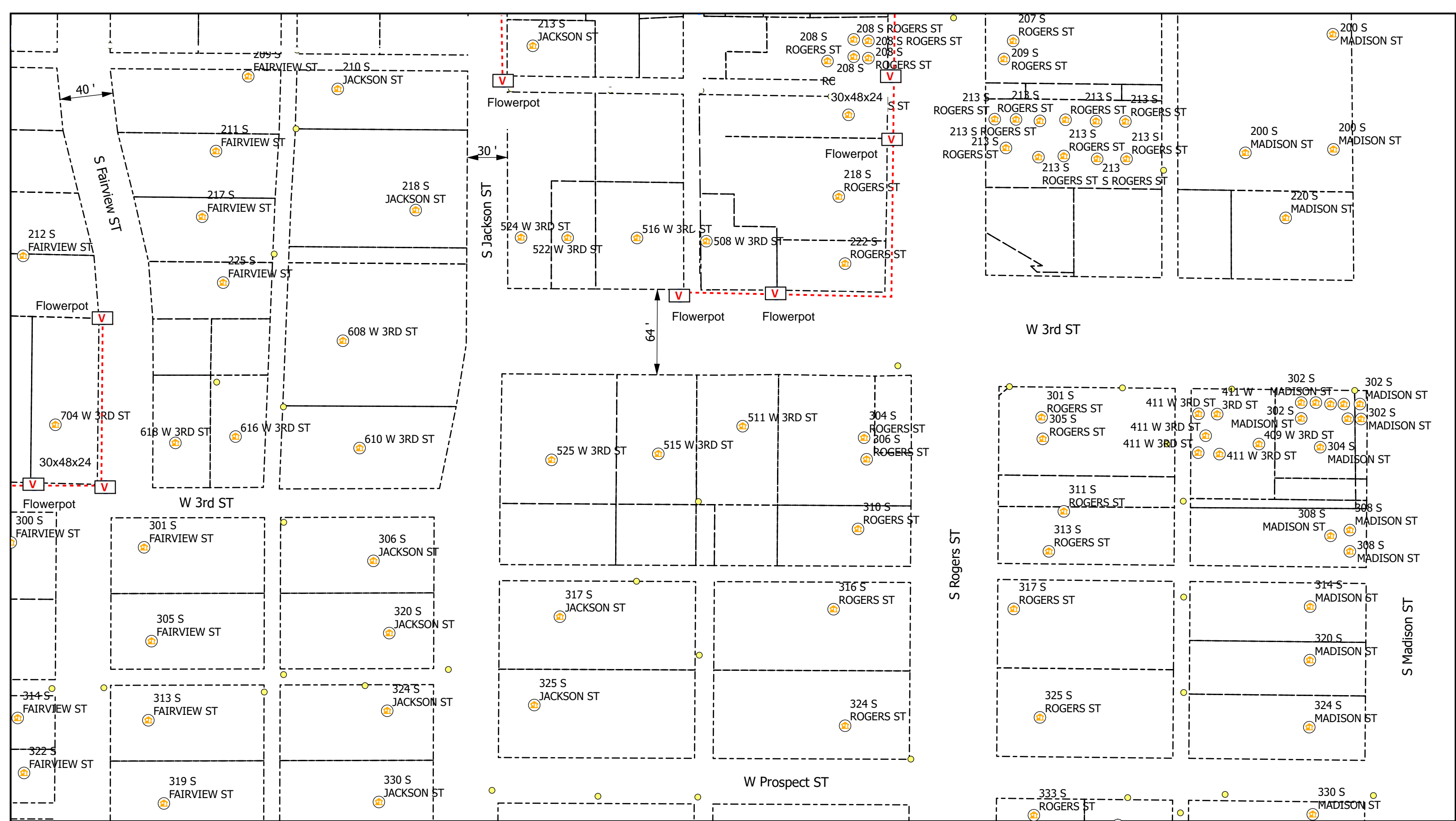

Legend

- Poles
- V Vaults
- Overhead Strand
- Conduit
- Ⓡ Risers
- 🏠 Address
- Y Anchor
- ↖ Sidewalk
- Bloomington_Parcels
- Grids

All Flowerpots 12" DIA



City of Bloomington, IN Permit:
Design View

INI	BY	DATE	DESCRIPTION



Carlton® PV-Mold® Nonmetallic Pole Riser System

Carlton PV-Mold is a nonmetallic pole riser system designed to protect communications power cable installed on poles.

Features:

- Meets or exceeds requirements outlined in the National Electric Safety Code (NESC).
- Designed in accordance with NEMA TC-19 specifications.
- Ultraviolet, cold temperature and corrosive atmosphere resistant.
- Schedule 40 wall meets Schedule 80 PVC conduit impact requirements per NEMA TC-19.
- No grounding required.
- Belled end fits over each added section or conduit.
- Flame retardant.
- Requires no maintenance.
- PV-Mold acts as an insulator against electrical shock.
- Interchangeable parts and accessories to match the needs of specific requirements.



Steel U-Guard requires grounding strapping and does not have belled ends.



PV-Mold has belled ends, flanged design and does not require grounding.

Flanged Overall Length 10 Feet, Including Bell

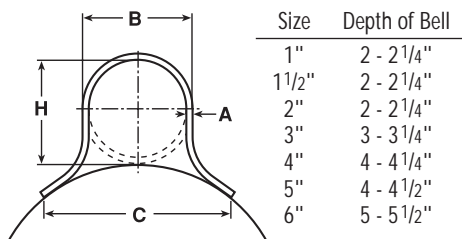

Slots are 1/2" from side to side, and allow for expansion and contraction.

Slot Dimensions: for sizes 2" through 6" are 5/16" wide, 3/4" long.

Slot Dimensions: for 1" and 1 1/2" are 3/16" wide, 3/4" long.

Slot Spacing: 18" from center, beginning 6" from end.

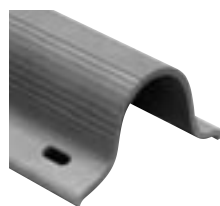

Standard Duty

Part No.	Size	Std. Ctn. Qty.	Std. Ctn. Wt. (lbs.)	Dimensions				Actual Impact @ 0°C 20 Pound Top
				A	B	C	H	
59208N	1"	294	1059	0.100"	1 5/8"	2 3/8"	1 5/8"	40 Ft.-Lbs.
59211N	2"	136	726	0.100"	2 3/8"	4 1/2"	2 3/8"	100 Ft.-Lbs.
59211X (5' length)	2"	136	363	0.100"	2 3/8"	4 1/2"	2 3/8"	100 Ft.-Lbs.
59213N	3"	66	761	0.150"	3 1/2"	6"	3 1/2"	110 Ft.-Lbs.
59213X (5' length)	3"	66	381	0.150"	3 1/2"	6"	3 1/2"	100 Ft.-Lbs.
59215N	4"	65	910	0.150"	4 1/2"	6 1/2"	4 1/2"	110 Ft.-Lbs.
59216N	5"	30	515	0.150"	5 1/2"	7 1/2"	5 1/2"	110 Ft.-Lbs.

Heavy Duty Schedule 40

59010N	1 1/2"	200	1142	0.145"	1 29/32"	3 1/2"	1 29/32"	100 Ft.-Lbs.
59011N	2"	136	1214	0.154"	2 3/8"	4 1/2"	2 3/8"	150 Ft.-Lbs.
59013N	3"	66	937	0.216"	3 1/2"	6"	3 9/32"	150 Ft.-Lbs.
59015N	4"	65	1621	0.237"	4 1/2"	6 1/2"	4 1/2"	260 Ft.-Lbs.
59015X (5' length)	4"	65	707	0.237"	4 1/2"	6 1/2"	4 1/2"	260 Ft.-Lbs.
59016N	5"	30	870	0.258"	5 1/2"	7 1/2"	5 1/2"	260 Ft.-Lbs.
59017N	6"	30	1160	0.280"	6 5/8"	8 3/4"	6 5/8"	260 Ft.-Lbs.

Extra Heavy Duty Schedule 80

59411N	2"	136	1549	0.218"	2 3/8"	4 1/2"	2 3/8"	300 Ft.-Lbs.
59413N	3"	66	1495	0.030"	3 1/2"	6"	3 1/2"	525 Ft.-Lbs.

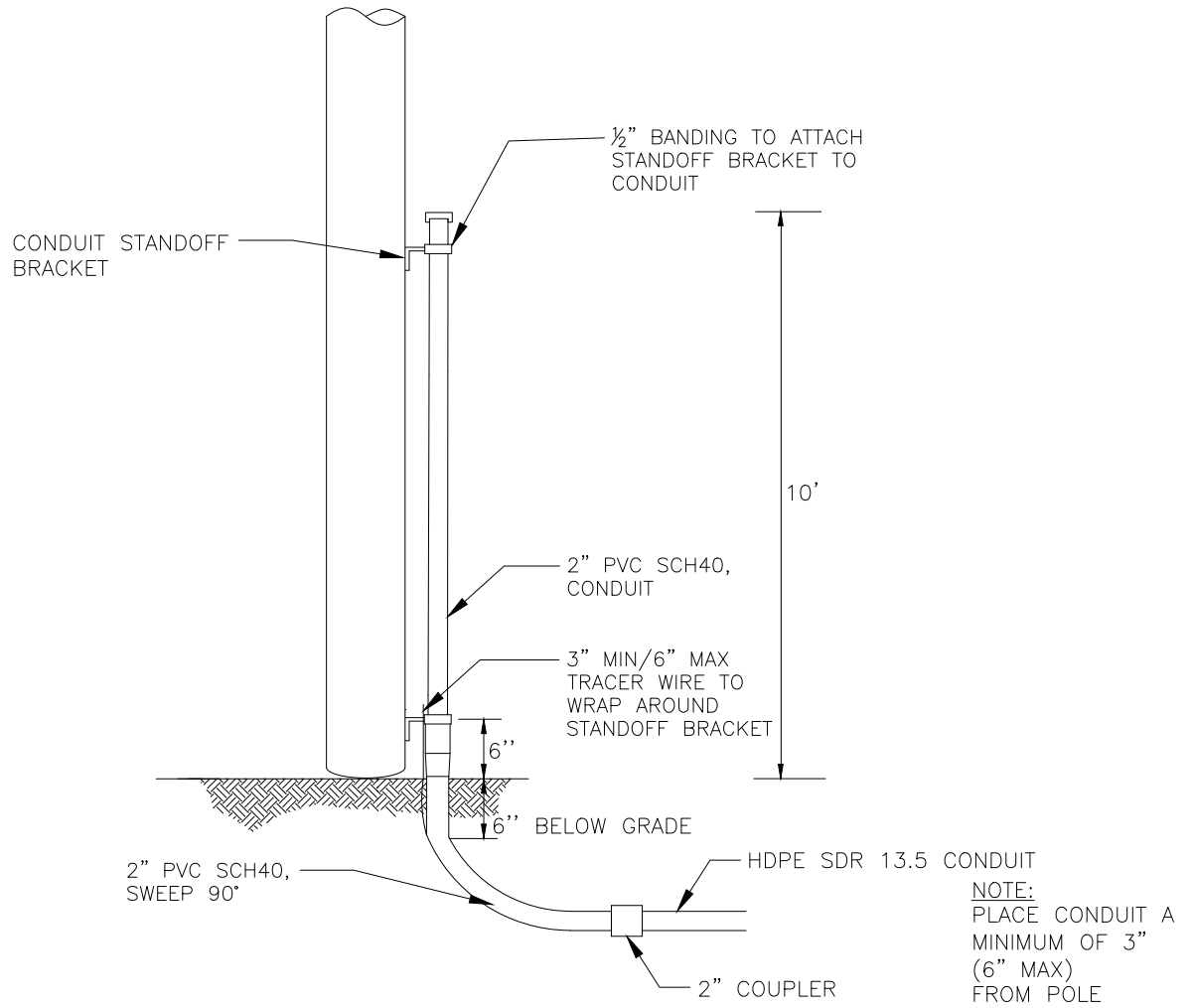

DESCRIPTION	QTY	MANUFACTURER (PREFERRED)	PART #
SCREW, LAG, 1/2" x 4-1/2"	10		
HDPE SDR 13.5 CONDUIT, VARIOUS SIZES	N/A		
2" PVC SCH40, RISER PIPE	1		
#12 TRACER WIRE	N/A		
2" PVC SCH40, SWEEP, 90 DEG	1		
CONDUIT STANDOFF BRACKET	VARIES		
CONDUIT STRAP KIT	VARIES		
2" COUPLER	1		



TYPICAL RISER
CONDUIT
WOOD POLE

(R2-W)

CONCEPTUAL SIDE VIEW

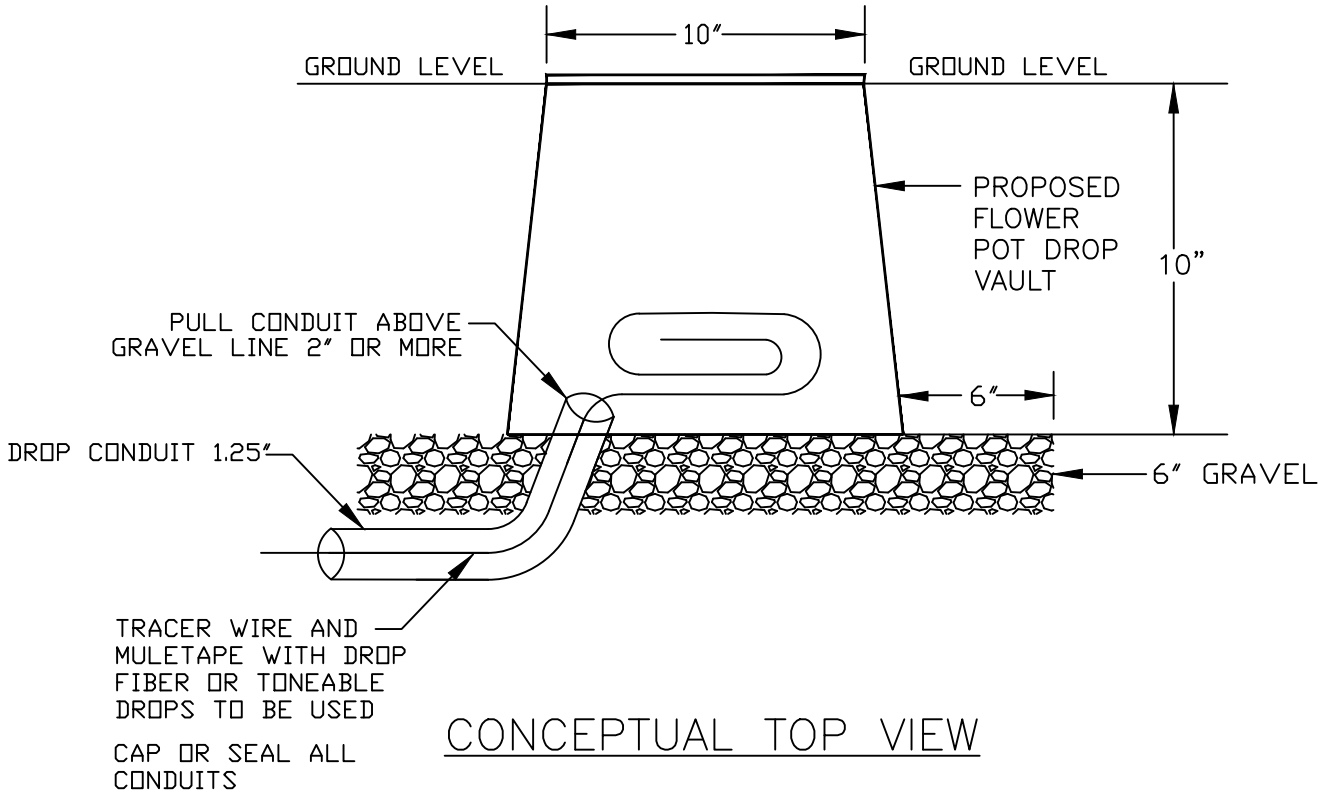

CONCEPTUAL TOP VIEW

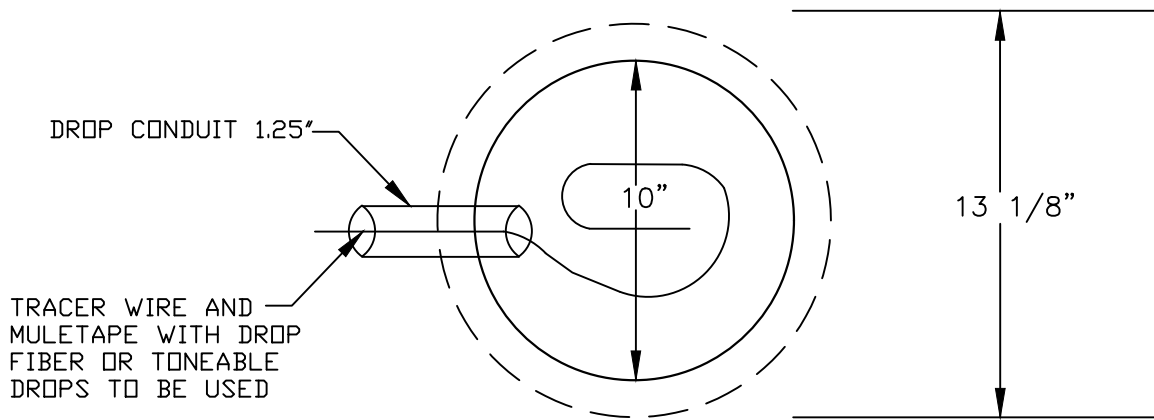

FLOWER POT

30"x48" PC UNIT, 2PC TIER 15/22
 18", 24", and 36" HEIGHT



AMERICAN POLYMER COMPANY

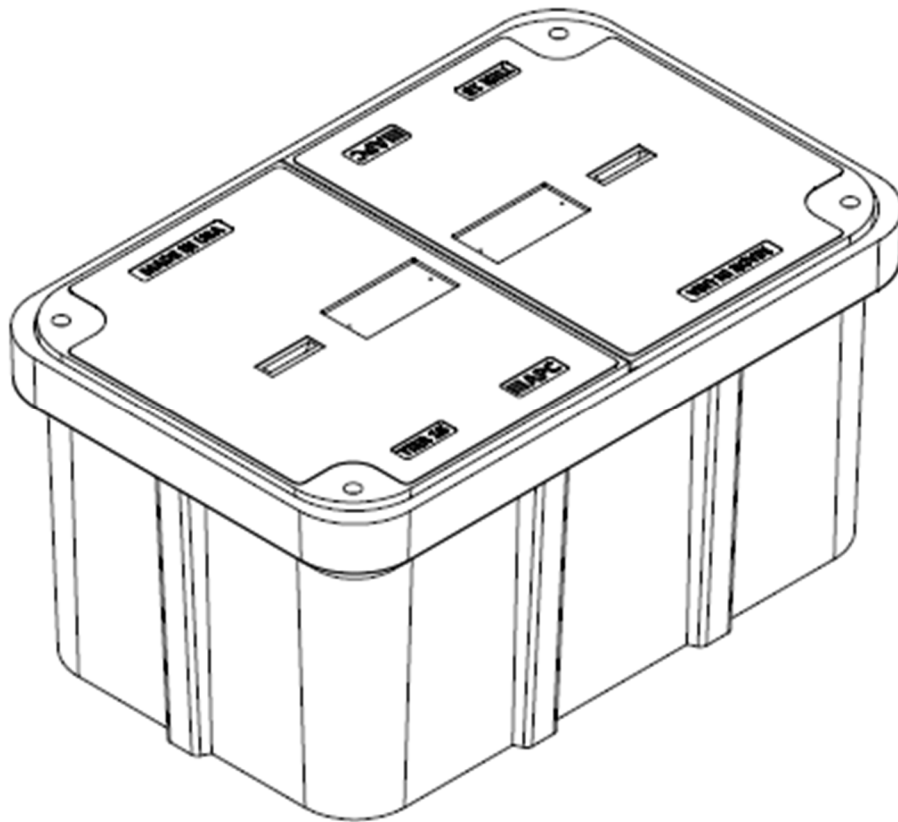

Description	Nominal Size	ANSI Tier	Part Number	Estimated Weight
PC Unit – TIER 15	30"x48"x18"	Tier 15	P304818HU15...	460 lbs.
PC Unit – TIER 22	30"x48"x18"	Tier 22	P304818HU22...	525 lbs.
PC Unit – TIER 15	30"x48"x24"	Tier 15	P304824HU15...	510 lbs.
PC Unit – TIER 22	30"x48"x24"	Tier 22	P304824HU22...	575 lbs.
PC Unit – TIER 15	30"x48"x36"	Tier 15	P304836HU15...	615 lbs.
PC Unit – TIER 22	30"x48"x36"	Tier 22	P304836HU22...	680 lbs.



30"x48" PC UNIT, 2PC TIER 15/22

18", 24", and 36" HEIGHT



AMERICAN POLYMER COMPANY

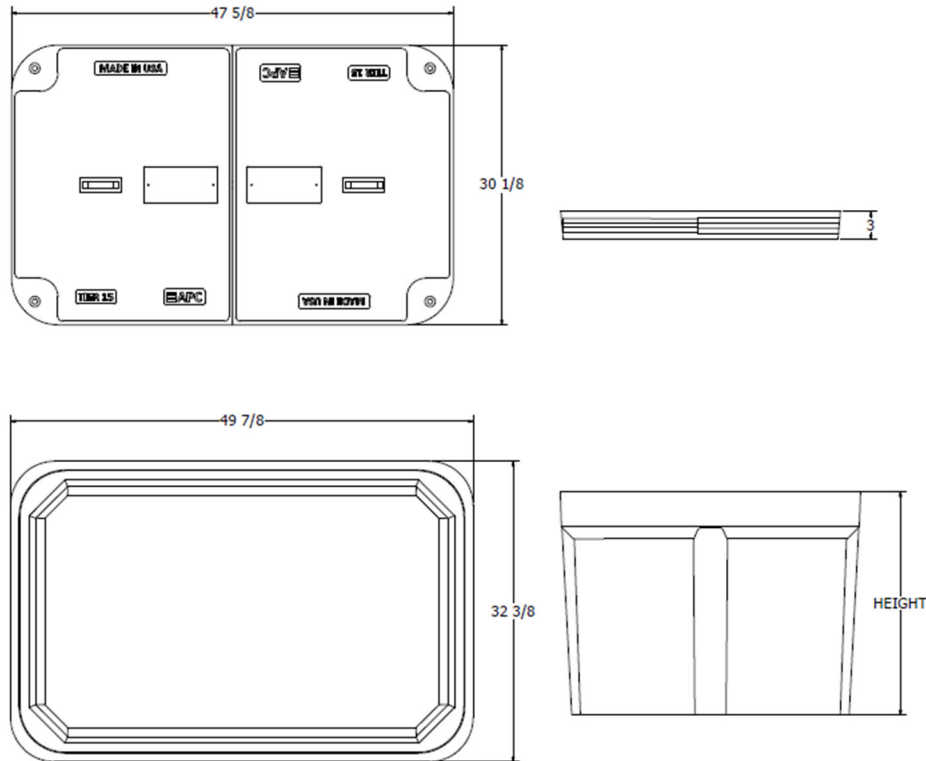

Components	Nominal Size	ANSI Tier	Part Number	Estimated Weight
Replacement Box	30"x48"x18"	Tier 22	P304818B22	185 lbs.
Replacement Box	30"x48"x24"	Tier 22	P304824B22	235 lbs.
Replacement Box	30"x48"x36"	Tier 22	P304836B22	340 lbs.
Replacement Lids - T15	30"x48" (half)	Tier 15	Various	150 lbs.
Replacement Lids - T22	30"x48" (half)	Tier 22	Various	170 lbs.

Bolt options



Machine Thread



Auger Thread



24"x36" PC UNIT, TIER 15/22
 18", 24", 30", and 36" HEIGHT



AMERICAN POLYMER COMPANY

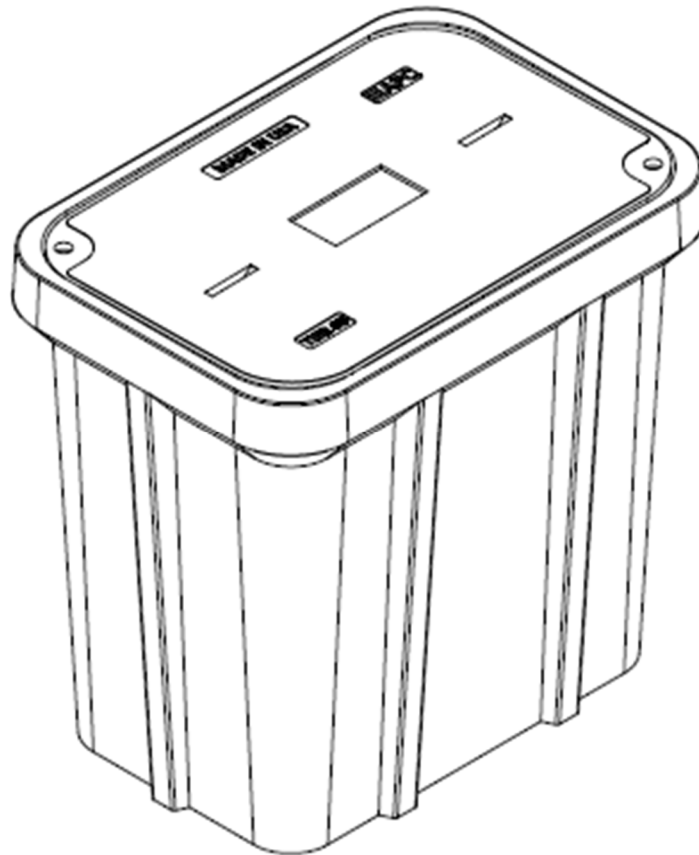

Description	Nominal Size	ANSI Tier	Part Number	Estimated Weight
PC Unit – TIER 15	24x36"x18"	Tier 15	P243618U15...	335 lbs.
PC Unit – TIER 22	24x36"x18"	Tier 22	P243618U22...	355 lbs.
PC Unit – TIER 15	24x36"x24"	Tier 15	P243624U15...	365 lbs.
PC Unit – TIER 22	24x36"x24"	Tier 22	P243624U22...	385 lbs.
PC Unit – TIER 15	24x36"x30"	Tier 15	P243630U15...	395 lbs.
PC Unit – TIER 22	24x36"x30"	Tier 22	P243630U22...	415 lbs.
PC Unit – TIER 15	24x36"x36"	Tier 15	P243636U15...	425 lbs.
PC Unit – TIER 22	24x36"x36"	Tier 22	P243636U22...	445 lbs.



24"x36" PC UNIT, TIER 15/22

18", 24", 30", and 36" HEIGHT



AMERICAN POLYMER COMPANY

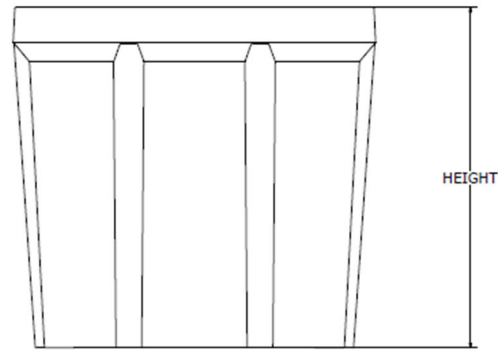
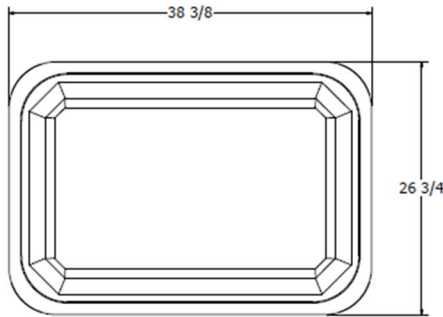
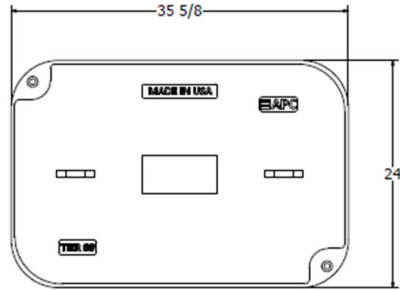

Components	Nominal Size	ANSI Tier	Part Number	Estimated Weight
Replacement Box	24"x36"x18"	Tier 22	P243618B22	165 lbs.
Replacement Box	24"x36"x24"	Tier 22	P243624B22	195 lbs.
Replacement Box	24"x36"x30"	Tier 22	P243630B22	225 lbs.
Replacement Box	24"x36"x36"	Tier 22	P243636B22	255 lbs.
Replacement Lids - T15	24"x36"	Tier 15	Various	170 lbs.
Replacement Lids - T22	24"x36"	Tier 22	Various	190 lbs.

Bolt options

Hex Head



Machine Thread



Penta Head



Auger Thread



17"x30" PC UNIT, TIER 15/22

12", 18", 24", and 30" HEIGHT



AMERICAN POLYMER COMPANY

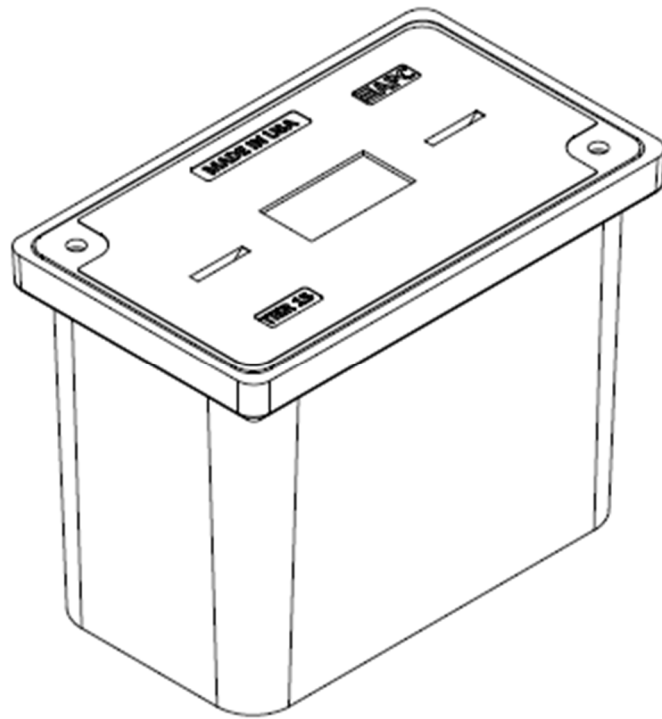

Description	Nominal Size	ANSI Tier	Part Number	Estimated Weight
PC Unit – TIER 15	17"x30"x12"	Tier 15	P173012U15...	138 lbs.
PC Unit – TIER 22	17"x30"x12"	Tier 22	P173012U22...	147 lbs.
PC Unit – TIER 15	17"x30"x18"	Tier 15	P173018U15...	172 lbs.
PC Unit – TIER 22	17"x30"x18"	Tier 22	P173018U22...	181 lbs.
PC Unit – TIER 15	17"x30"x24"	Tier 15	P173024U15...	192 lbs.
PC Unit – TIER 22	17"x30"x24"	Tier 22	P173024U22...	201 lbs.
PC Unit – TIER 15	17"x30"x30"	Tier 15	P173030U15...	217 lbs.
PC Unit – TIER 22	17"x30"x30"	Tier 22	P173030U22...	226 lbs.



17"x30" PC UNIT, TIER 15/22

12", 18", 24", and 30" HEIGHT



AMERICAN POLYMER COMPANY

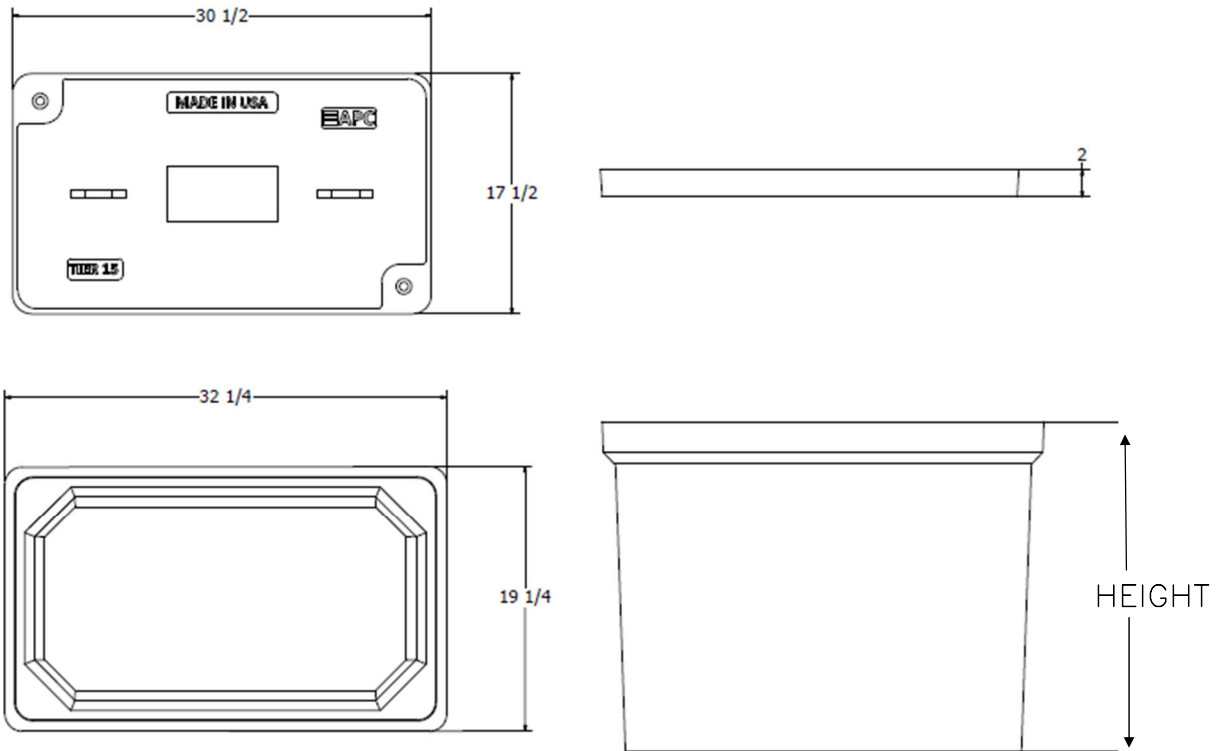

Components	Nominal Size	ANSI Tier	Part Number	Estimated Weight
Replacement Box	17"x30"X12"	Tier 22	P173012B22	66 lbs.
Replacement Box	17"x30"X18"	Tier 22	P173018B22	100 lbs.
Replacement Box	17"x30"X24"	Tier 22	P173024B22	120 lbs.
Replacement Box	17"x30"X30"	Tier 22	P173030B22	145 lbs.
Replacement Lids – T15	17"x30"	Tier 15	Various	72 lbs.
Replacement Lids – T22	17"x30"	Tier 22	Various	81 lbs.

Bolt options



Machine Thread



Auger Thread



33"x60" PC UNIT, 2PC TIER 15/22
36" HEIGHT



AMERICAN POLYMER COMPANY

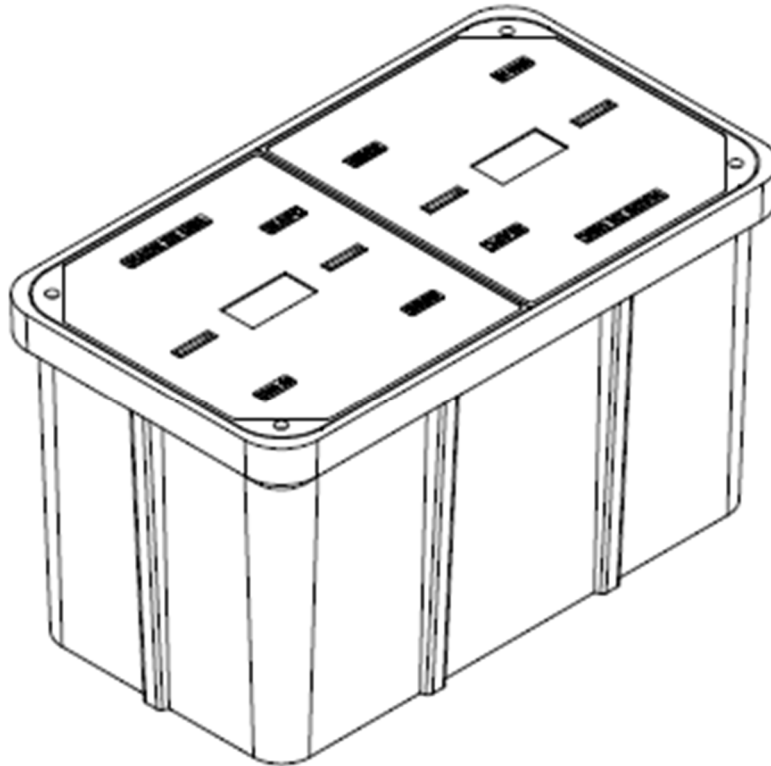

Description	Nominal Size	ANSI Tier	Part Number	Estimated Weight
PC Unit - TIER 15	33"x60"x36"	Tier 15	P336036U15...	930 lbs.
PC Unit - TIER 22	33"x60"x36"	Tier 22	P336036U22...	1030 lbs.



33"x60" PC UNIT, 2PC TIER 15/22

36" HEIGHT



AMERICAN POLYMER COMPANY

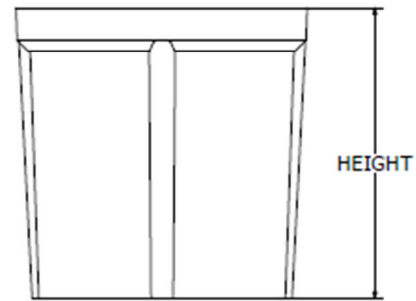
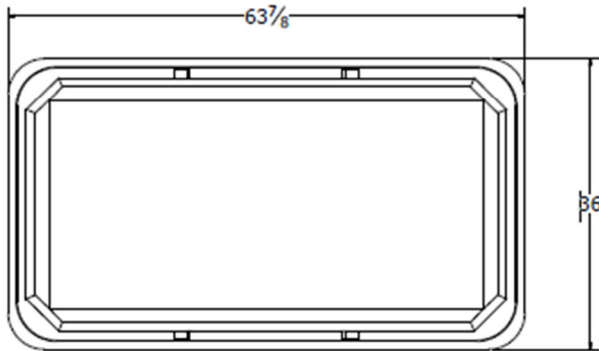
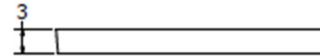

Components	Nominal Size	ANSI Tier	Part Number	Estimated Weight
Replacement Box	33"x60"x36"	Tier 22	P336036B22	530 lbs.
Replacement Lids - T15	33"x60" (half)	Tier 15	Various	200 lbs.
Replacement Lids - T22	33"x60" (half)	Tier 22	Various	250 lbs.

Bolt options

Hex Head



Machine Thread



Penta Head



Auger Thread



Speed (MPH) Prior To Road Work	SIGN SPACING, FT.		Must be Approved by an Engineer				
	Non-Divided Highways	Divided Highways	BUFFER SPACE, FT.	TAPER LENGTH, FT.	CHANNELIZING SPACING, FT.		
	Length	Shoulder (10 ft. Width)	Lane (12 ft. Width)	Through Taper	Through Buffer/Work Area		
0-35	200	200	250	70	245	35	50
40-45	350	500	360	150	540	40	80
50-55	500	1000	495	185	660	50	100
60-70	SA-1000, SB-1500, SC-2640		730	235	840	60	120
	Urban Low Speed - 100 FT						

APPROVED/ACCEPTED BY:
ENGINEER, OWNER, or PRIME CONTRACTOR
 Check for Notice to Proceed.

Signature: _____

Company: _____

Date: 12/7/2023 **Project:** BLN01b-F11 N Williams St TCP ;
Traffic Control Suggestion For: ATLANTIC ENGINEERING (AEG) ;
By: Road Runner Safety Services, Inc. : Nathan

Comments:
 Drawing not to scale. Traffic control plan must be approved by an engineer. This is a suggestion only. Road Runners Safety Services, Inc. has no liability for this suggested traffic control plan. Actual placement and spacing of all traffic control devices will depend on field conditions and must conform to MUTCD standards.

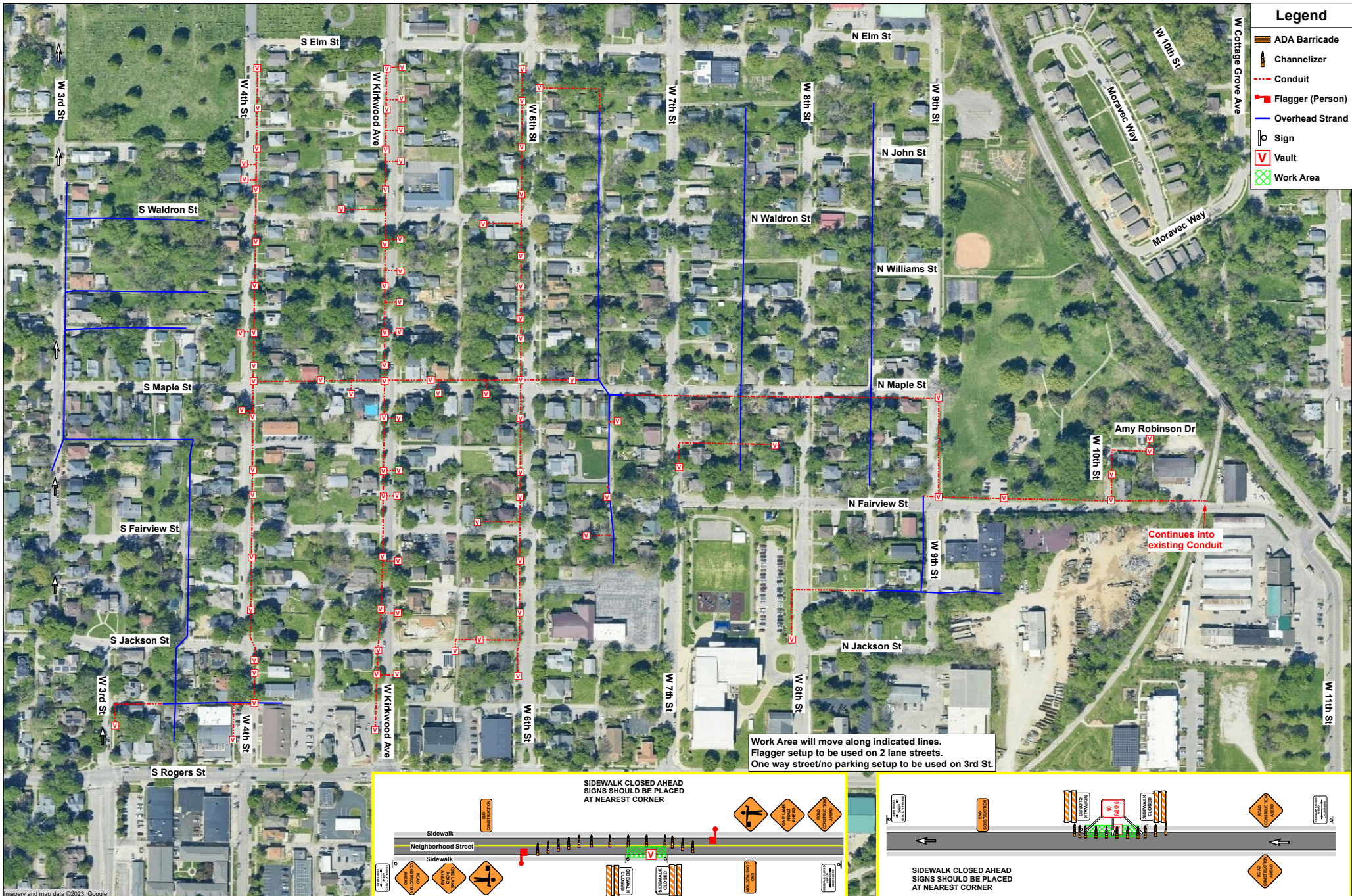

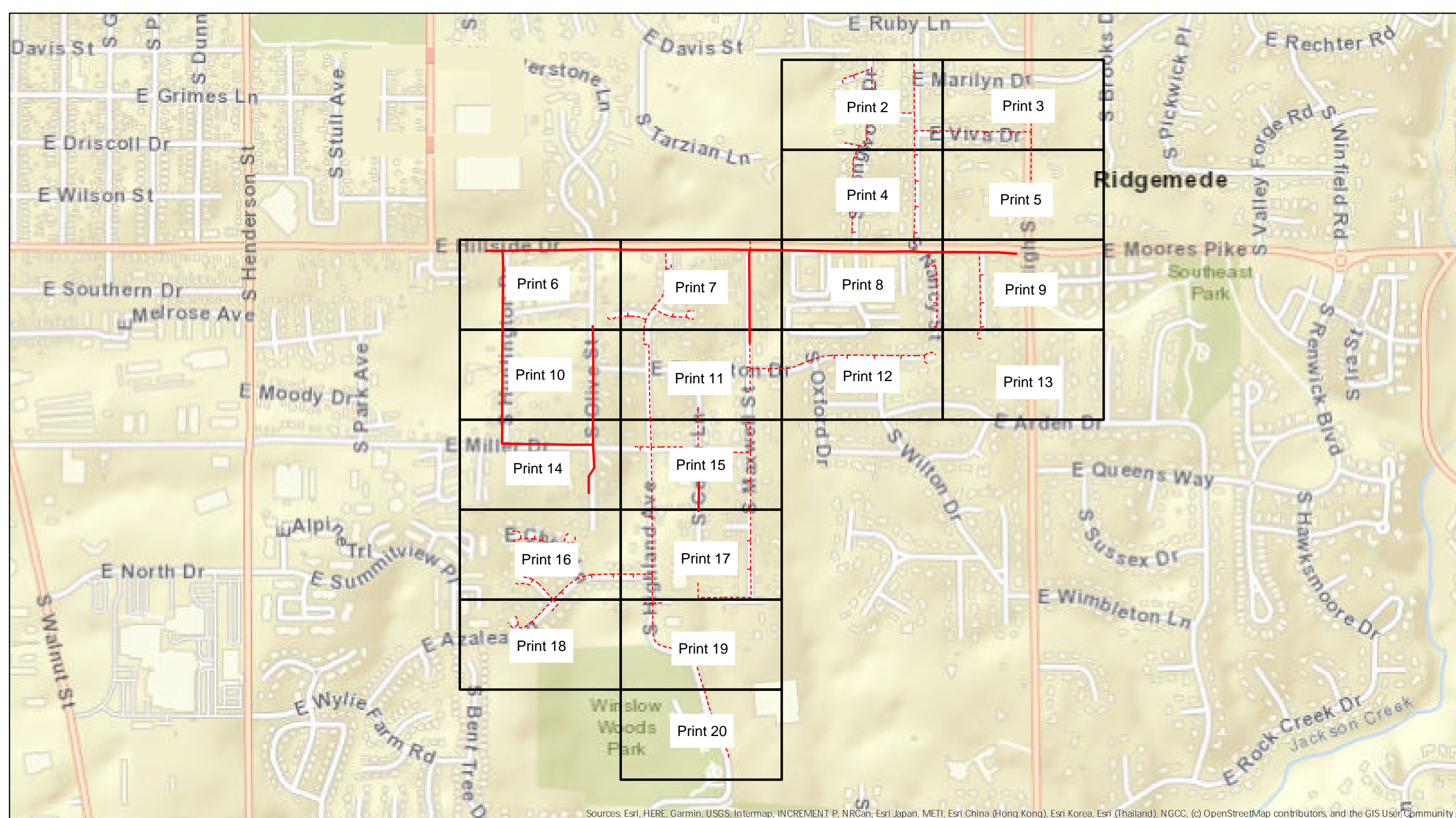

Sources: Esri, HERE, Garmin, USGS, Intermap, INCREMENT P, NRCan, Esri Japan, METI, Esri China (Hong Kong), Esri Korea, Esri (Thailand), NGCC, (c) OpenStreetMap contributors, and the GIS User Community



Legend BLC02a-F14_S Maxwell St

- Overhead Strand
- ⋯ Conduit
- Grids

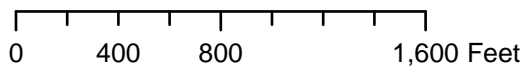

City of Bloomington, IN Permit:
Design View

INI	BY	DATE	DESCRIPTION



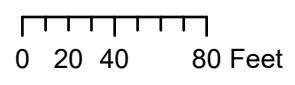
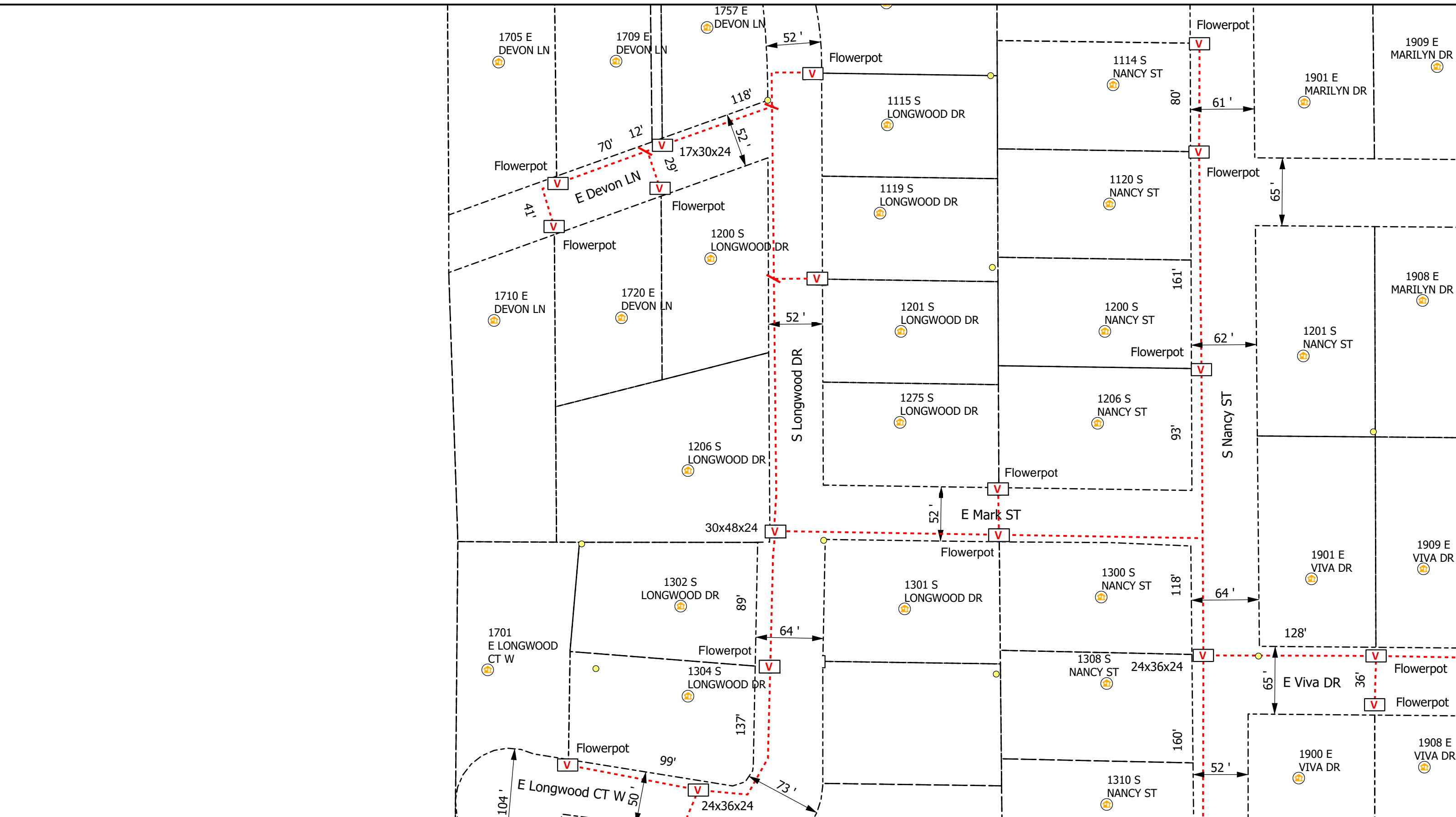

Legend

- Poles
- Vaults
- Overhead Strand
- Conduit
- Bloomington_Parcels
- Risers
- Address
- Anchor
- Sidewalk
- Grids

All Flowerpots 12" DIA



City of Bloomington, IN Permit:
Design View

INI	BY	DATE	DESCRIPTION



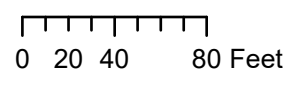
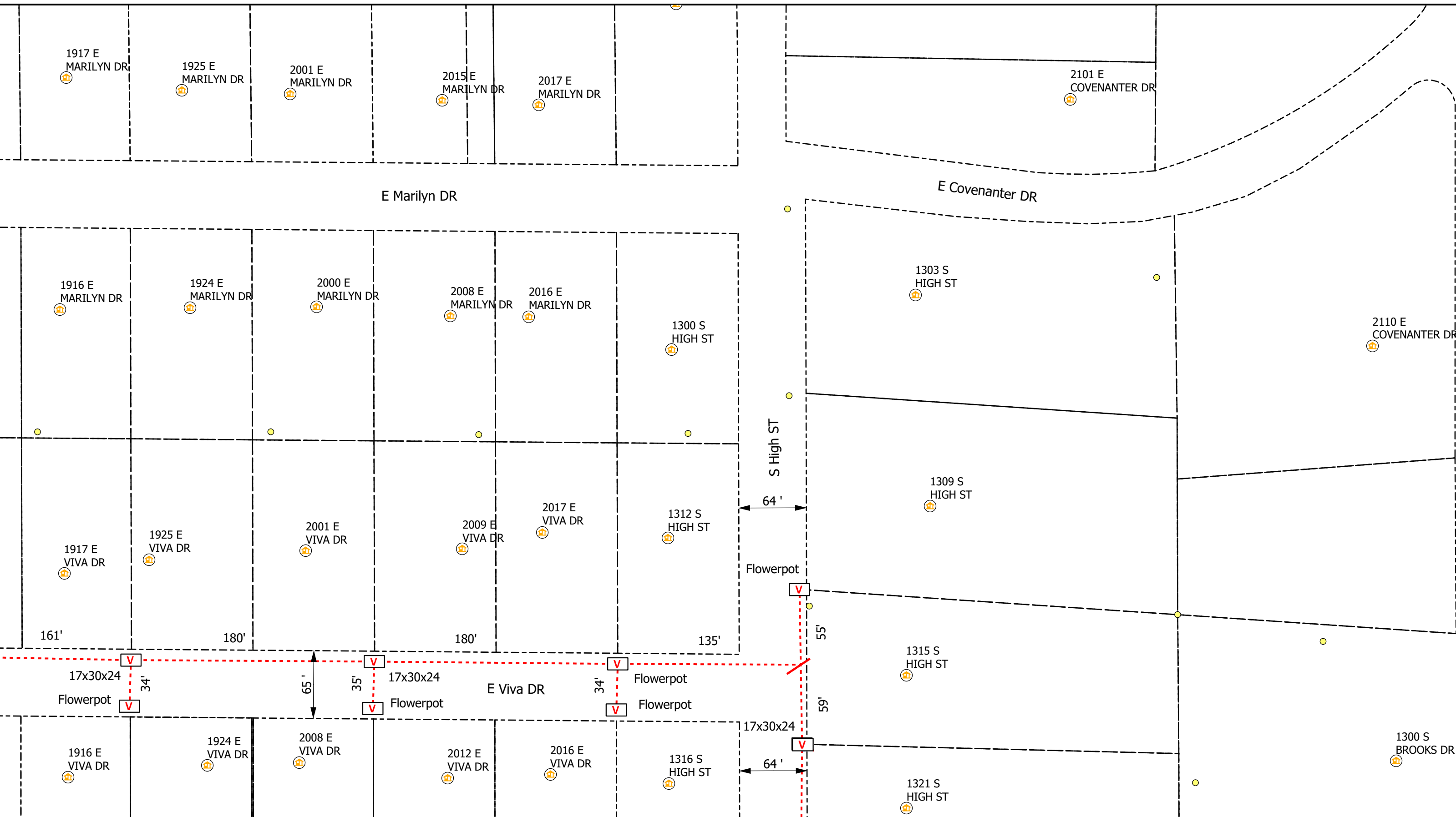

Legend

- Poles
- V Vaults
- Overhead Strand
- Conduit
- Bloomington_Parcels
- R Risers
- A Address
- Y Anchor
- ← Sidewalk
- Grids

All Flowerpots 12" DIA



City of Bloomington, IN Permit:
Design View

INI	BY	DATE	DESCRIPTION



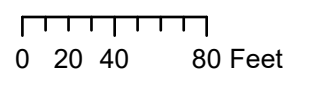
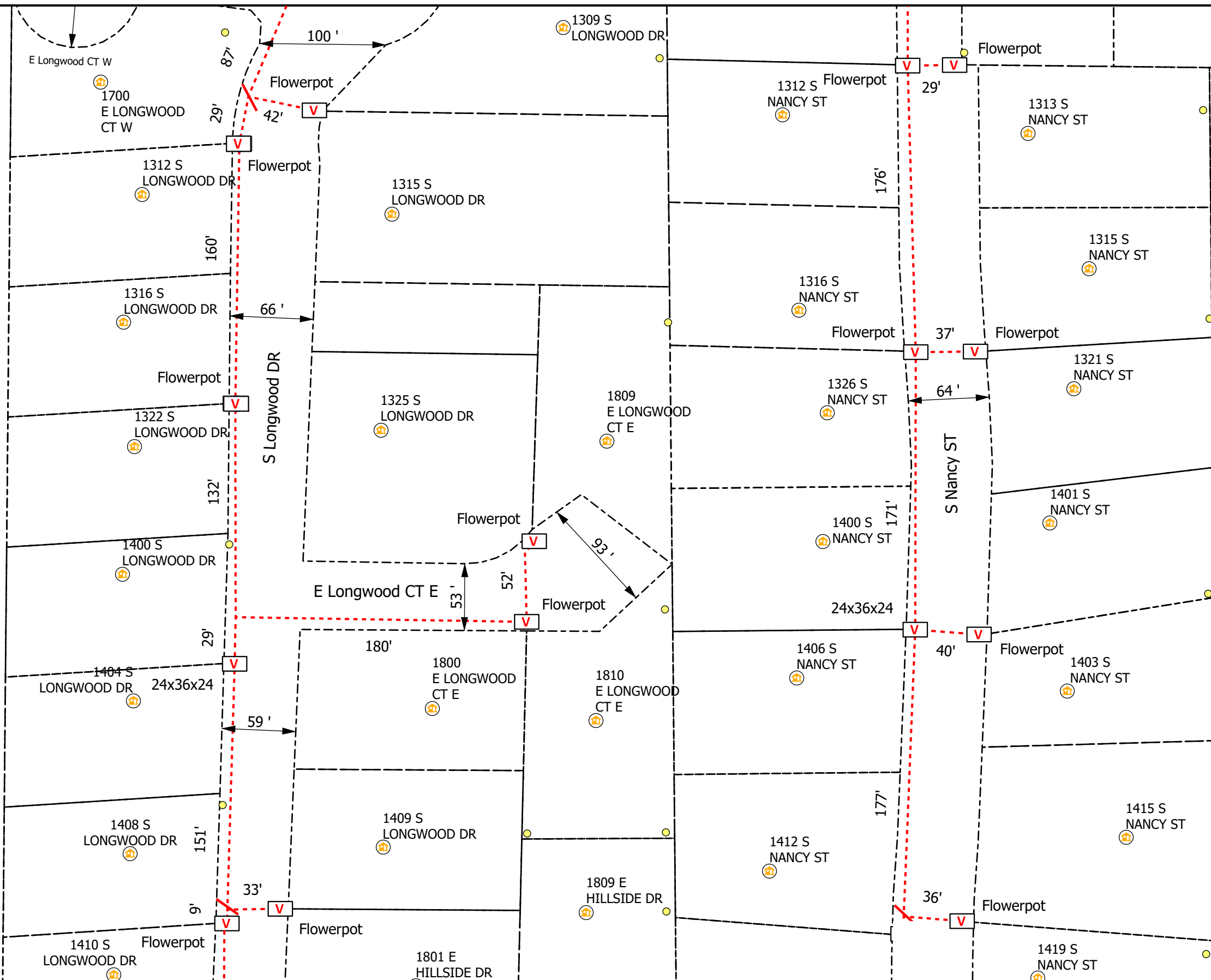

Legend

- Poles
- V Vaults
- Overhead Strand
- Conduit
- Bloomington_Parcels
- R Risers
- ⊙ Address
- Y Anchor
- ← Sidewalk
- Grids

All Flowerpots 12" DIA



City of Bloomington, IN Permit:
Design View

INI	BY	DATE	DESCRIPTION



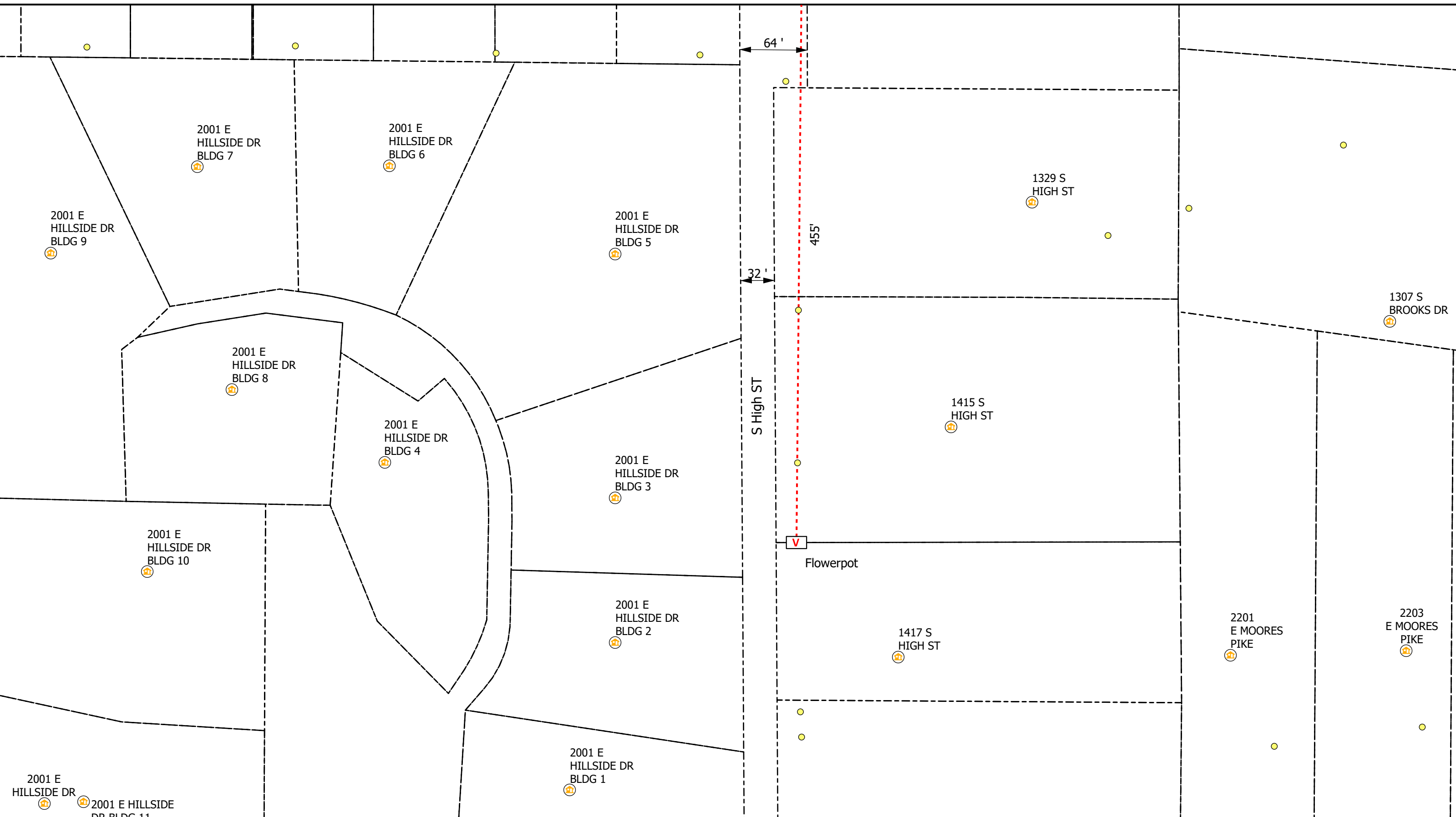

0 20 40 80 Feet

Legend

- Poles
- V Vaults
- Overhead Strand
- - - Conduit
- Bloomington_Parcels
- Ⓜ Risers
- Ⓜ Address
- Y Anchor
- ← Sidewalk
- Grids

All Flowerpots 12" DIA

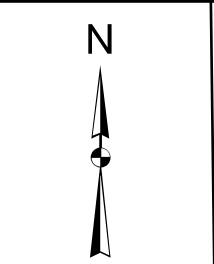

City of Bloomington, IN Permit:
Design View

INI	BY	DATE	DESCRIPTION

Print 5 of 20

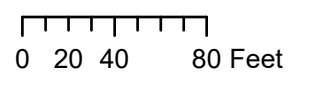
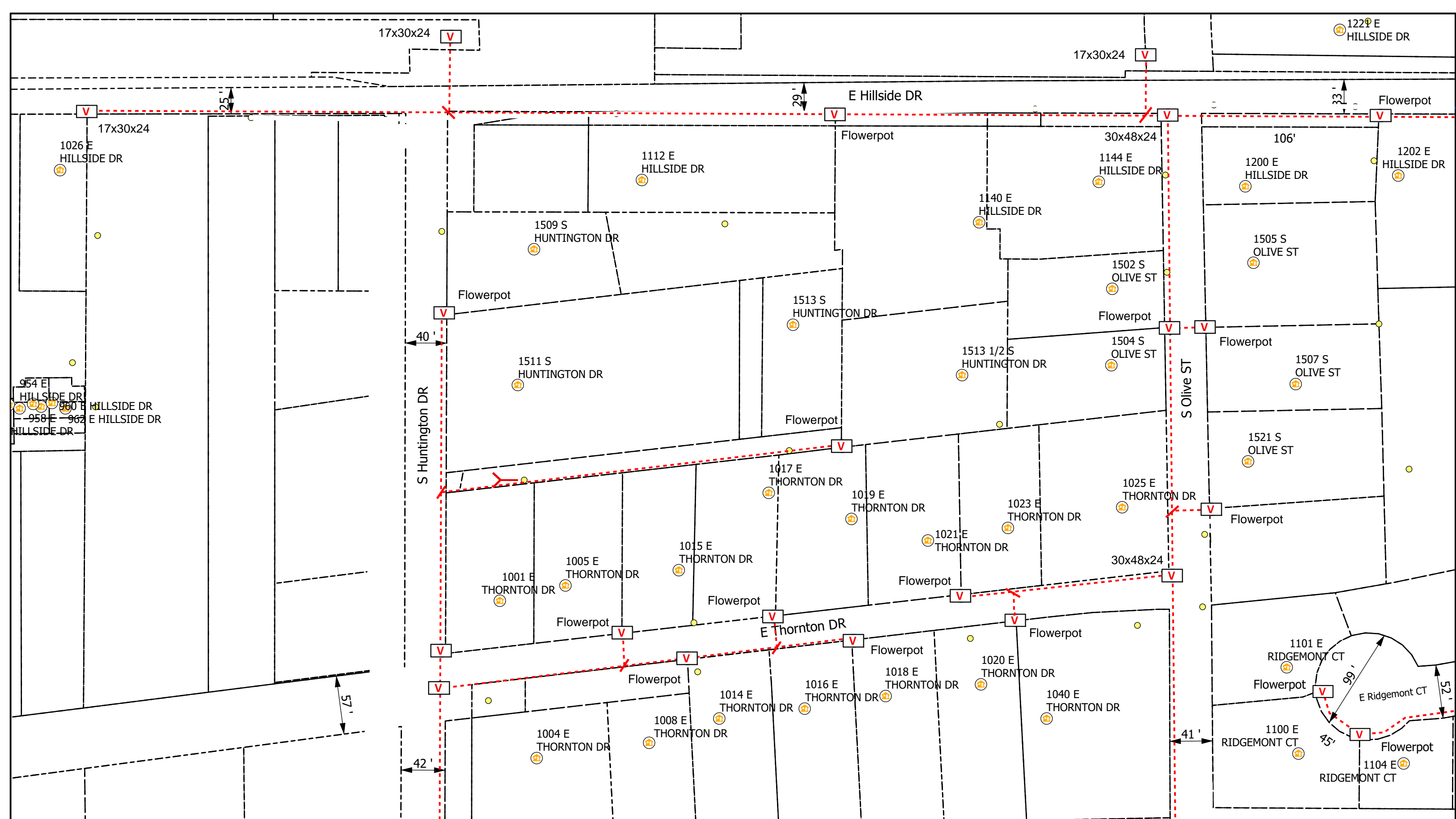

Legend

- Poles
- V Vaults
- Overhead Strand
- Conduit
- Bloomington_Parcels
- R Risers
- A Address
- Y Anchor
- ← Sidewalk
- Grids

All Flowerpots 12" DIA



City of Bloomington, IN Permit:
Design View

INI	BY	DATE	DESCRIPTION



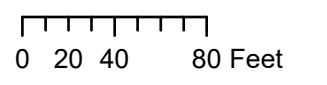
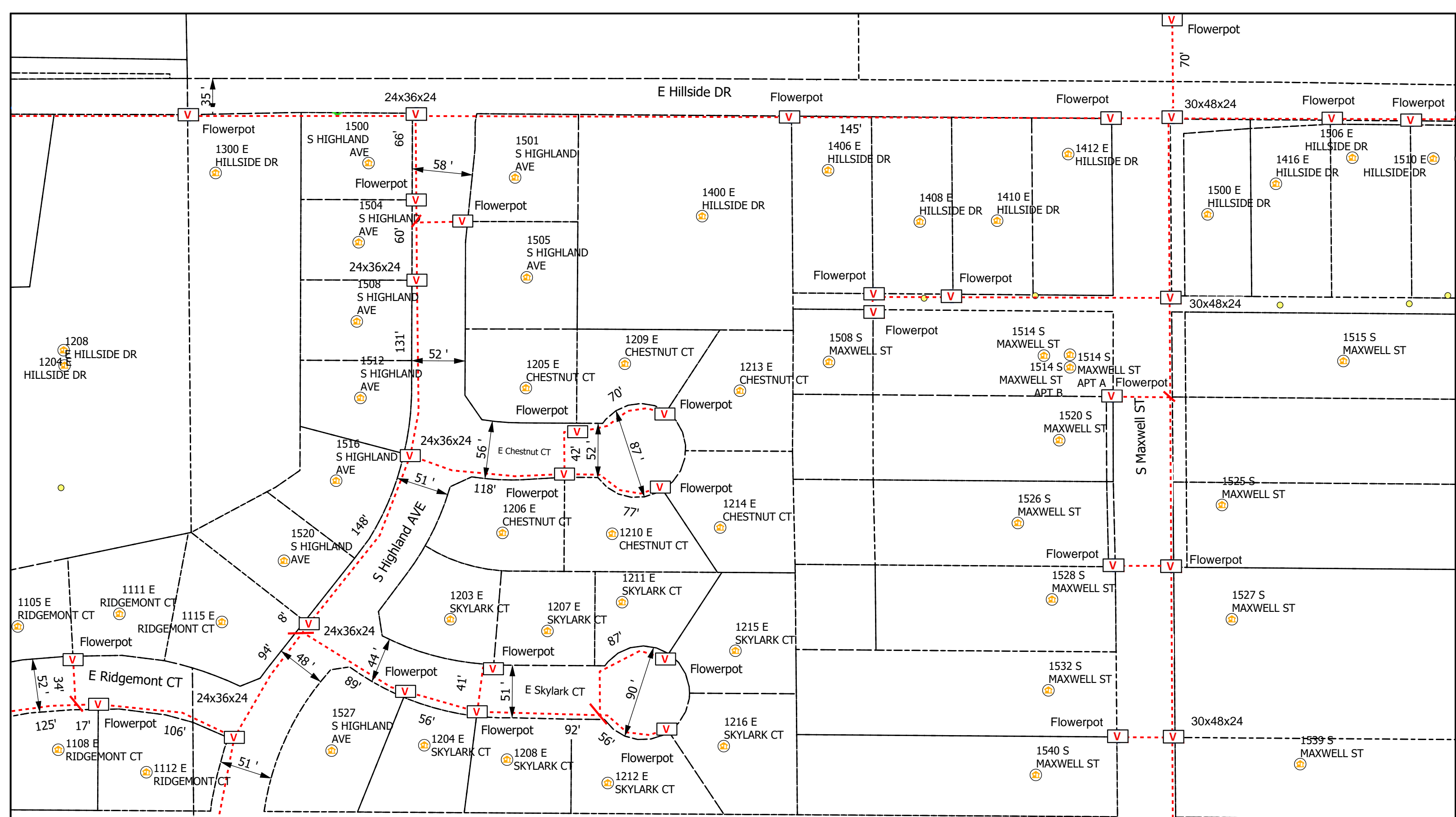

Legend

- Poles
- Vaults
- Overhead Strand
- Conduit
- Bloomington_Parcels
- Risers
- Address
- Anchor
- Sidewalk
- Grids

All Flowerpots 12" DIA



City of Bloomington, IN Permit:
Design View

INI	BY	DATE	DESCRIPTION



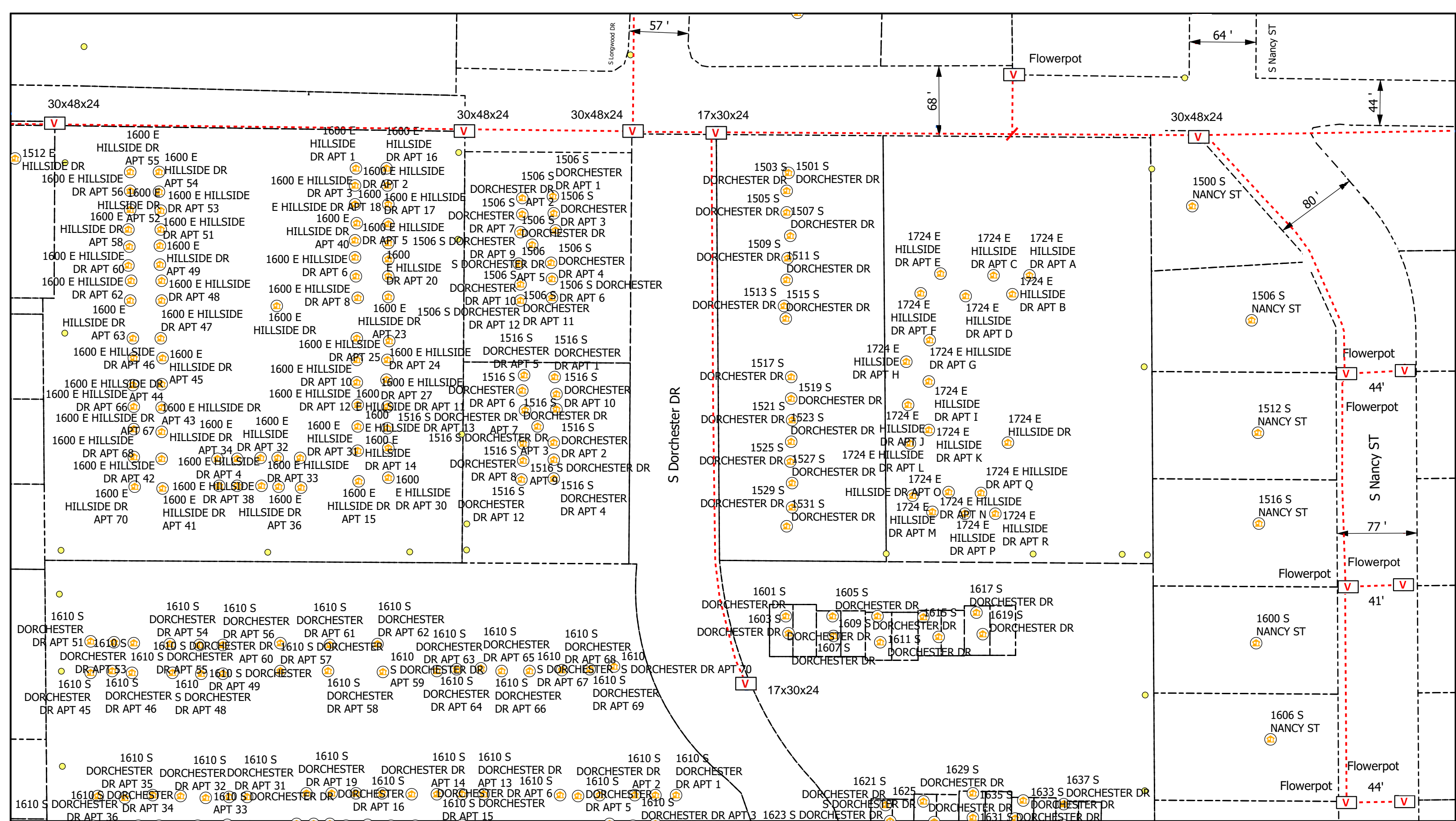

0 20 40 80 Feet

Legend

- Poles
- Vaults
- Overhead Strand
- Conduit
- Bloomington_Parcels
- Risers
- Address
- Anchor
- Sidewalk
- Grids

All Flowerpots 12" DIA

N



City of Bloomington, IN Permit:
Design View

INI	BY	DATE	DESCRIPTION



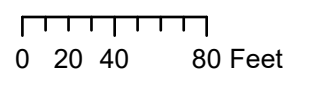
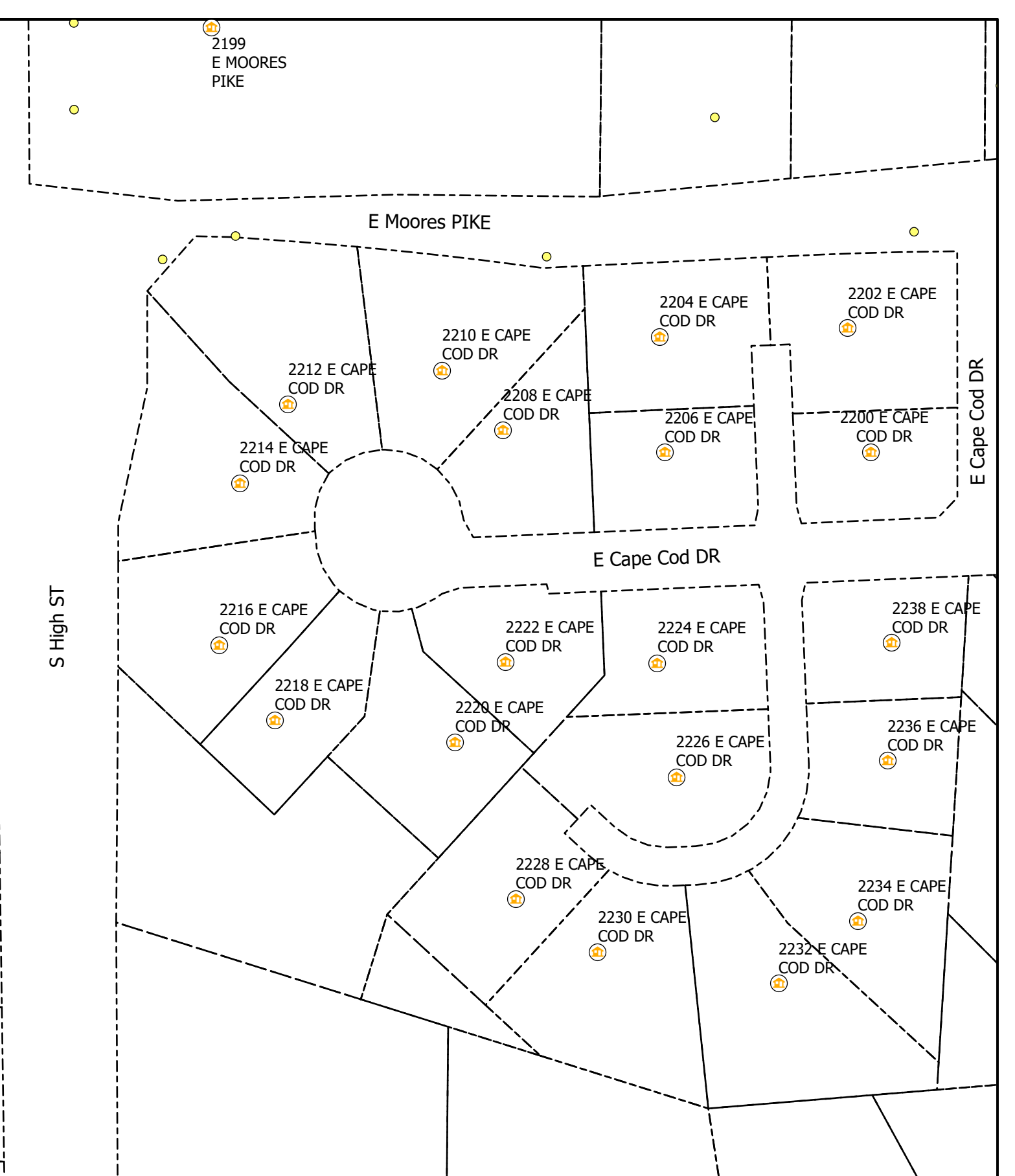
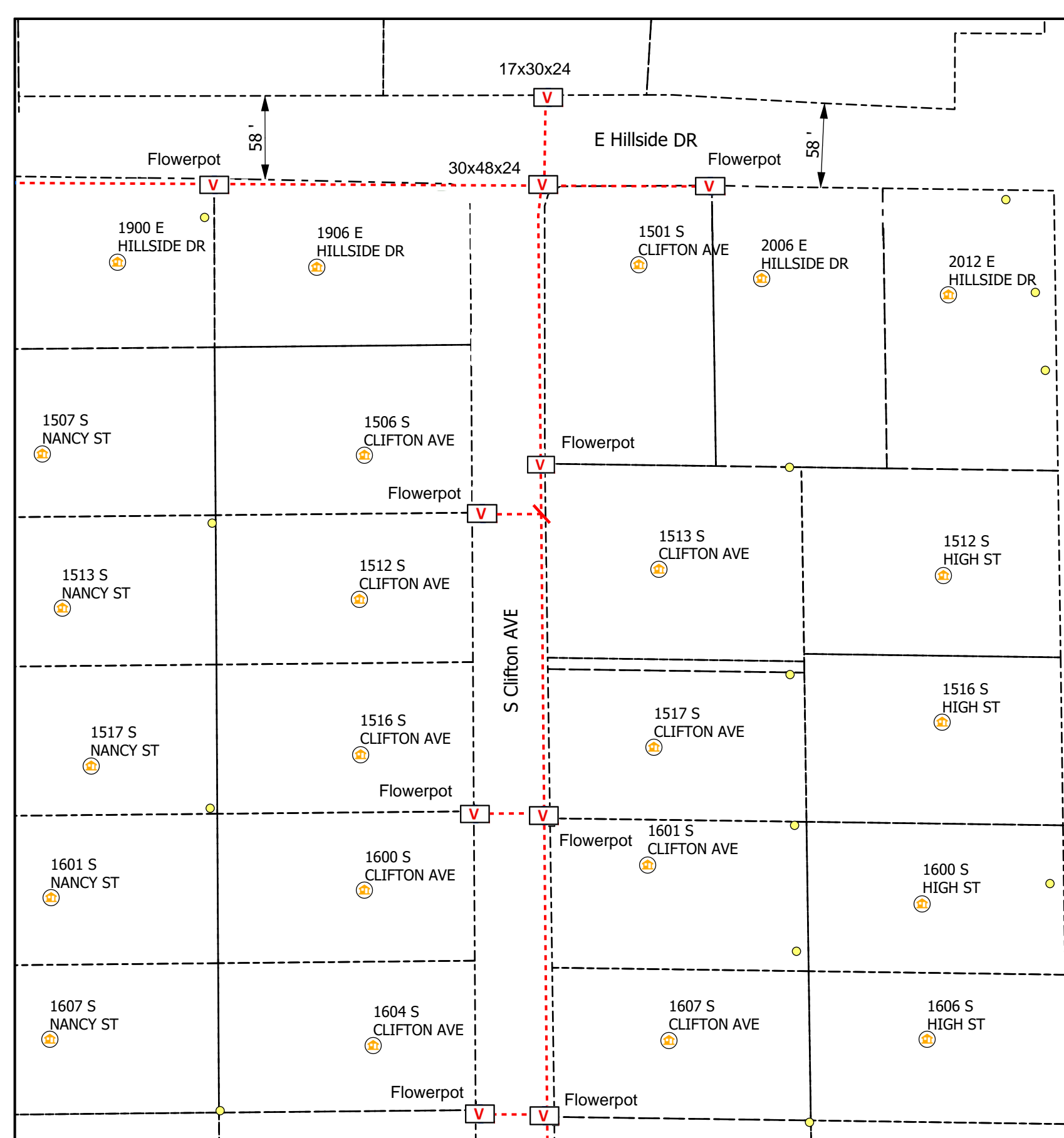

Legend

- Poles
- V Vaults
- Overhead Strand
- Conduit
- Bloomington_Parcels
- Risers
- Address
- Anchor
- Sidewalk
- Grids

All Flowerpots 12" DIA



City of Bloomington, IN Permit:
Design View

INI	BY	DATE	DESCRIPTION



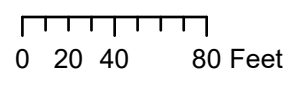
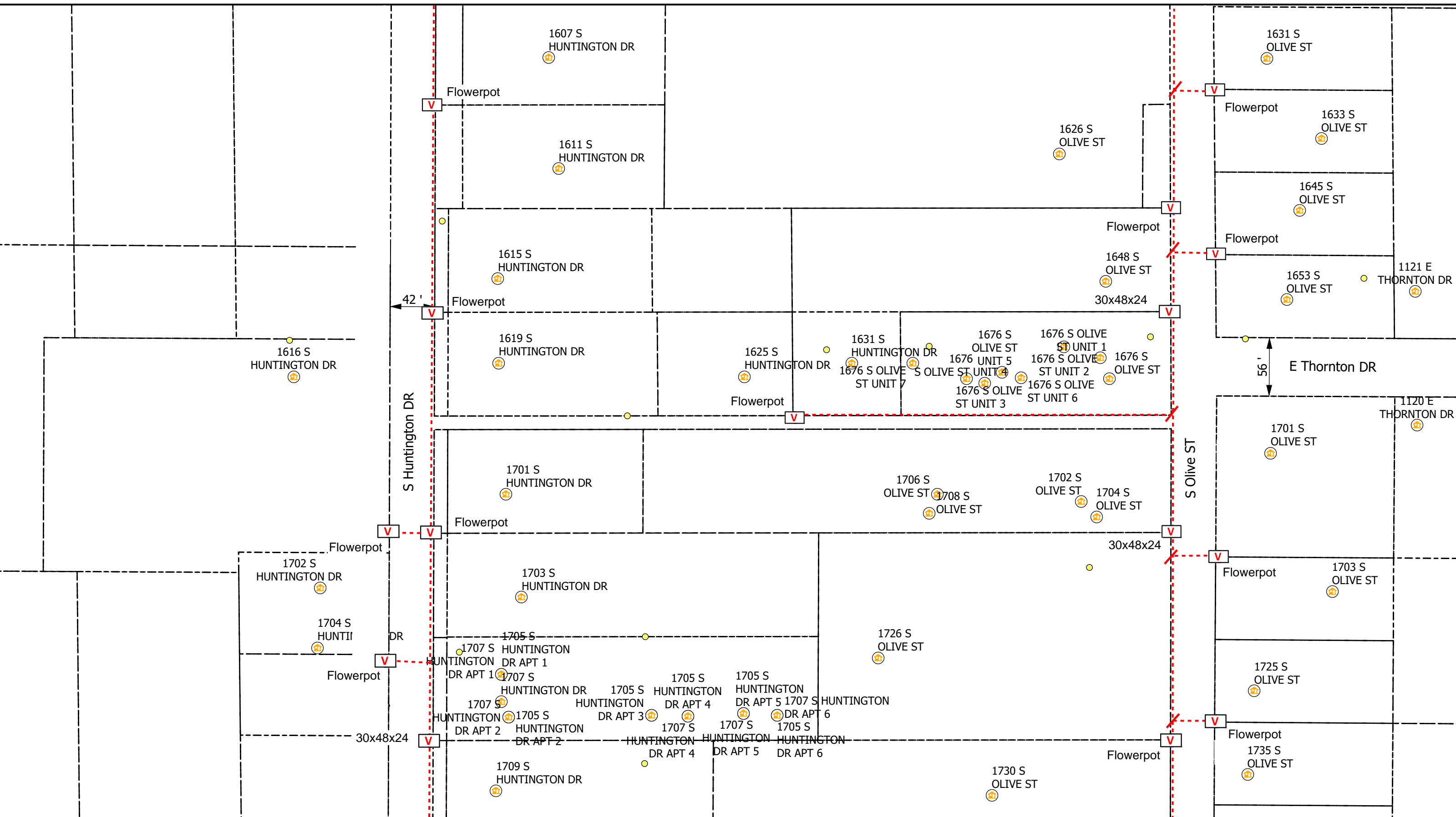

Legend

- Poles
- V Vaults
- Overhead Strand
- Conduit
- Bloomington_Parcels
- R Risers
- A Address
- Y Anchor
- K Sidewalk
- Grids

All Flowerpots 12" DIA



City of Bloomington, IN Permit:
Design View

INI	BY	DATE	DESCRIPTION



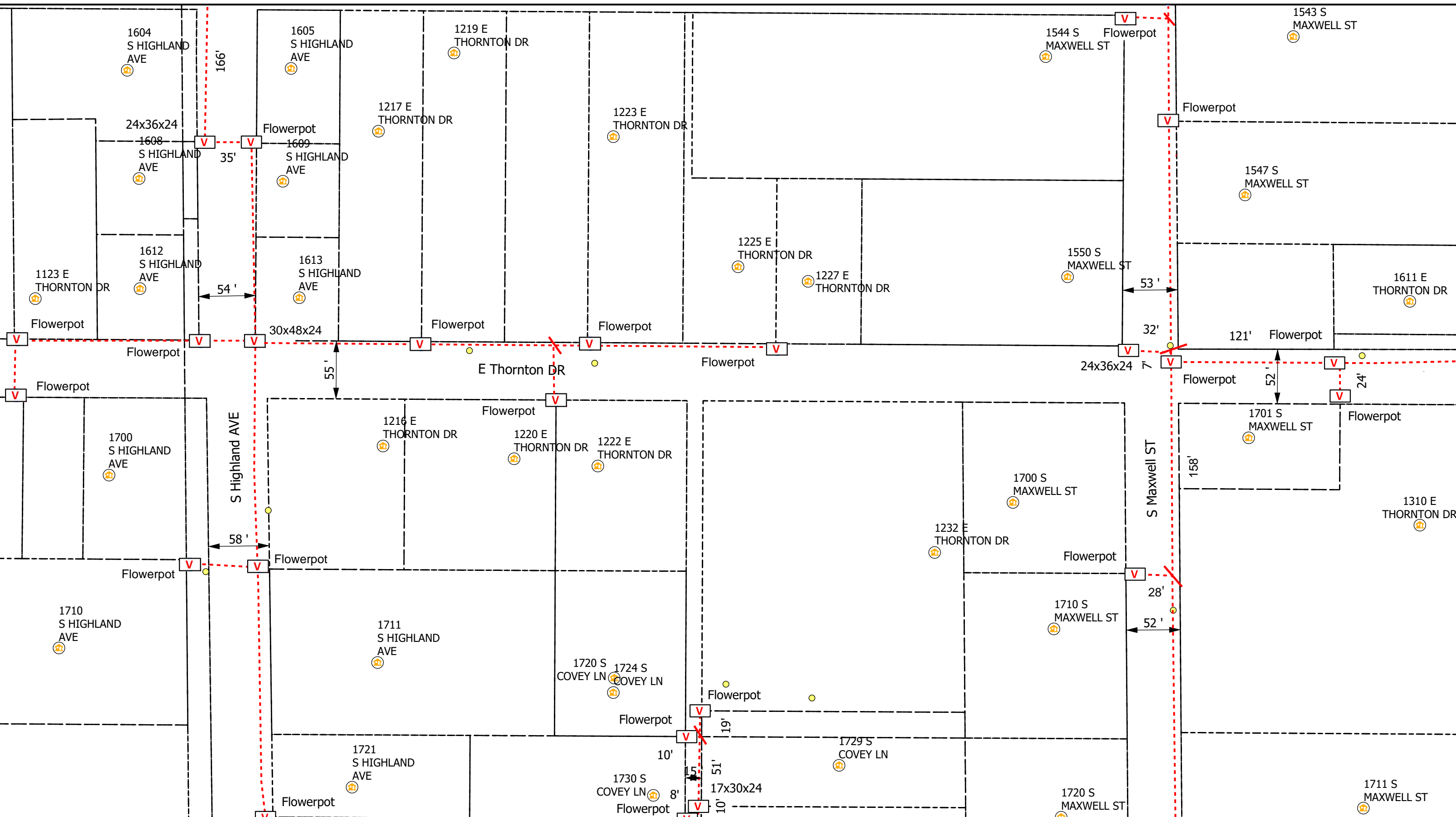

0 20 40 80 Feet

Legend

- Poles
- Vaults
- Overhead Strand
- Conduit
- Bloomington_Parcels
- Risers
- Address
- Anchor
- Sidewalk
- Grids

All Flowerpots 12" DIA



City of Bloomington, IN Permit:
Design View

INI	BY	DATE	DESCRIPTION



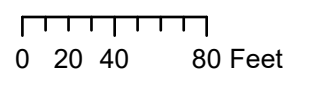
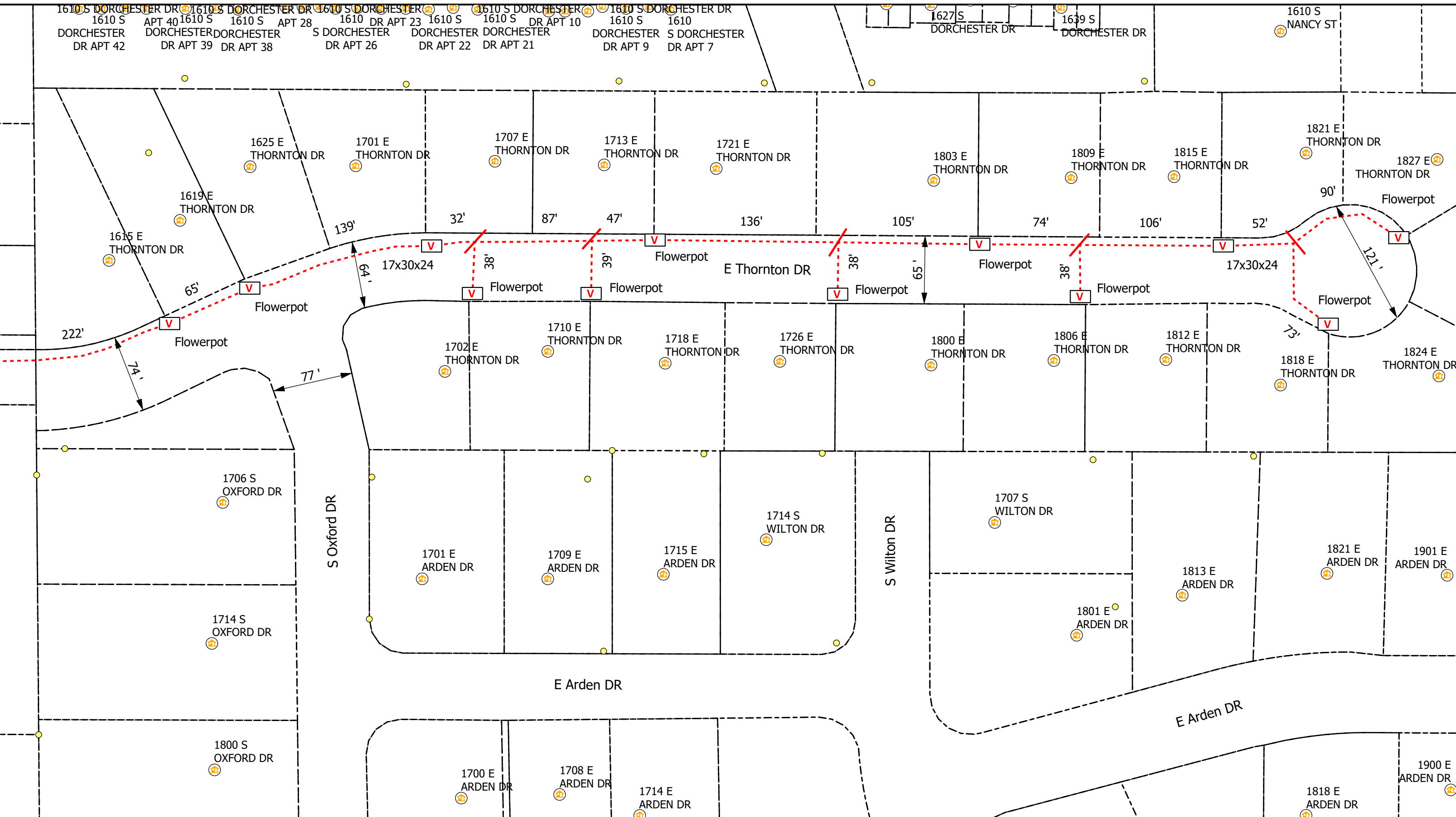

Legend

- Poles
- Conduit
- Overhead Strand
- Vaults
- Bloomington_Parcels
- Risers
- Address
- Anchor
- Sidewalk
- Grids

All Flowerpots 12" DIA



City of Bloomington, IN Permit:
Design View

INI	BY	DATE	DESCRIPTION



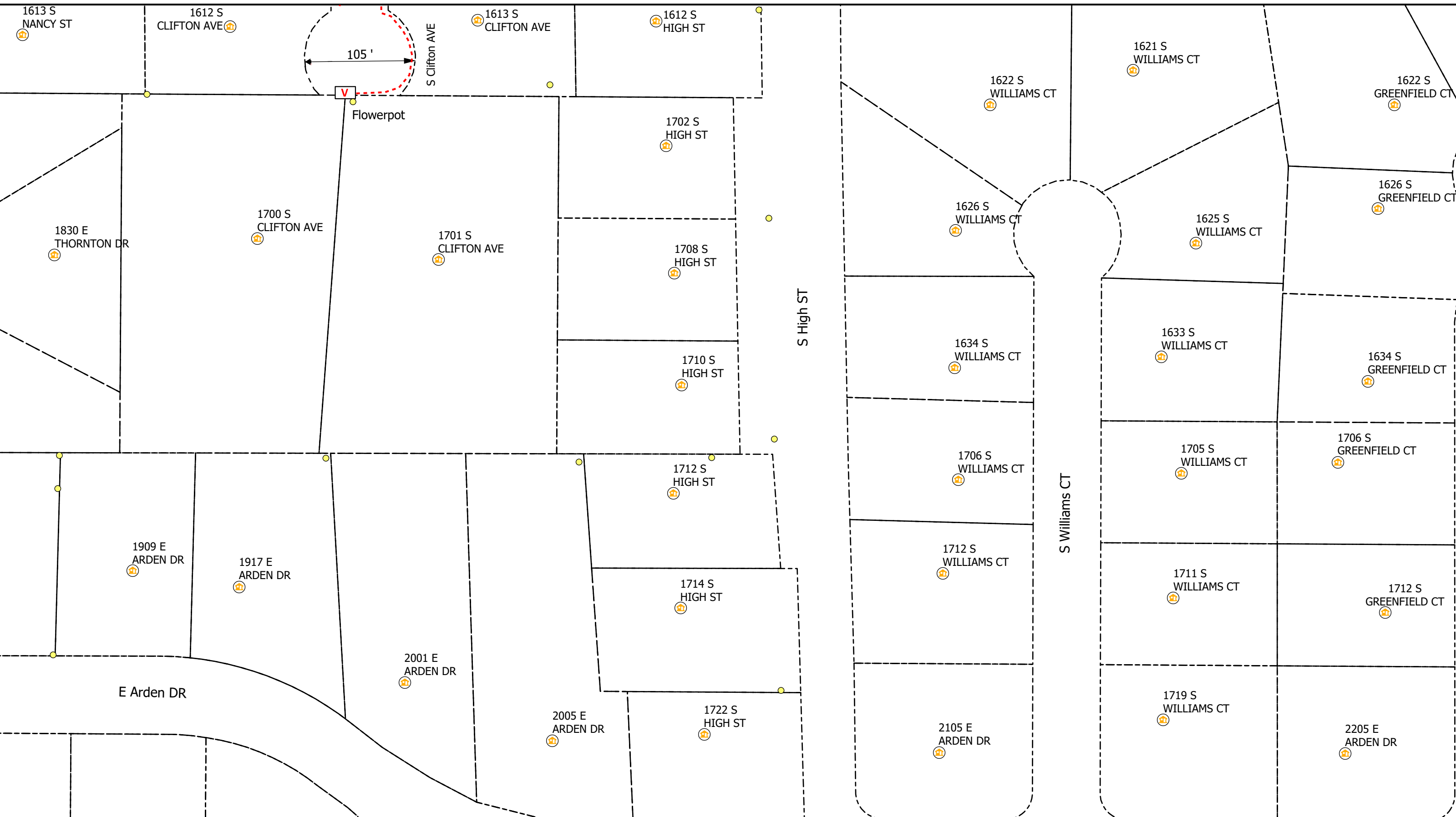

0 20 40 80 Feet

Legend

- Poles
- V Vaults
- Overhead Strand
- - - Conduit
- Bloomington_Parcels
- R Risers
- A Address
- Y Anchor
- ← Sidewalk
- Grids

All Flowerpots 12" DIA

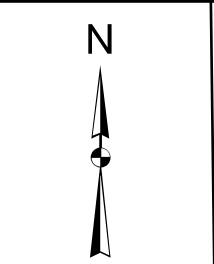

City of Bloomington, IN Permit:
Design View

INI	BY	DATE	DESCRIPTION

Print 13 of 20

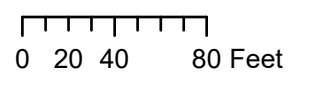
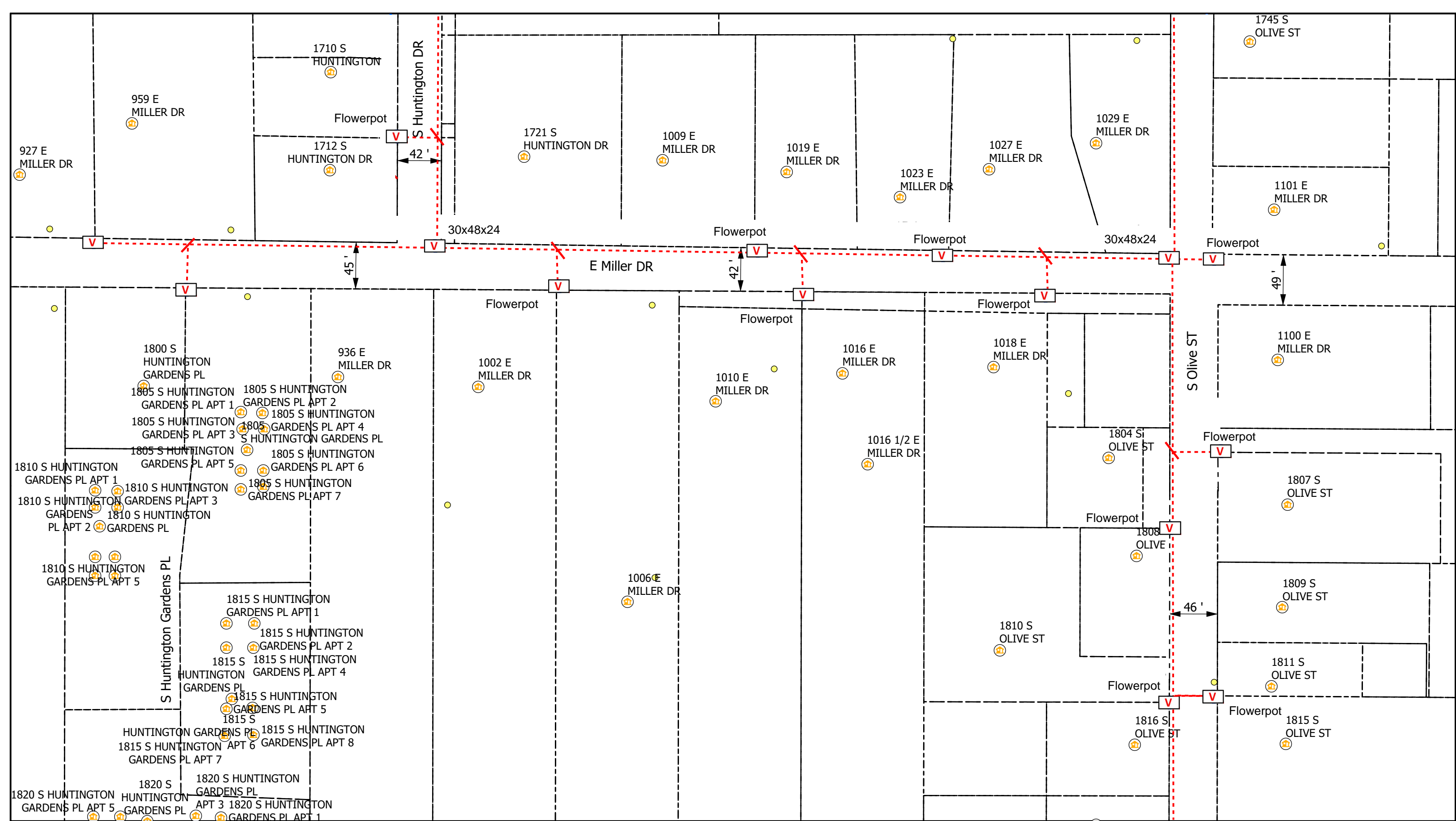

Legend

- Poles
- Vaults
- Overhead Strand
- Conduit
- Risers
- Address
- Anchor
- Sidewalk
- Grids
- Bloomington_Parcels

All Flowerpots 12" DIA



City of Bloomington, IN Permit:
Design View

INI	BY	DATE	DESCRIPTION



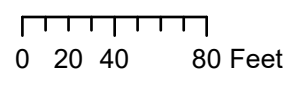
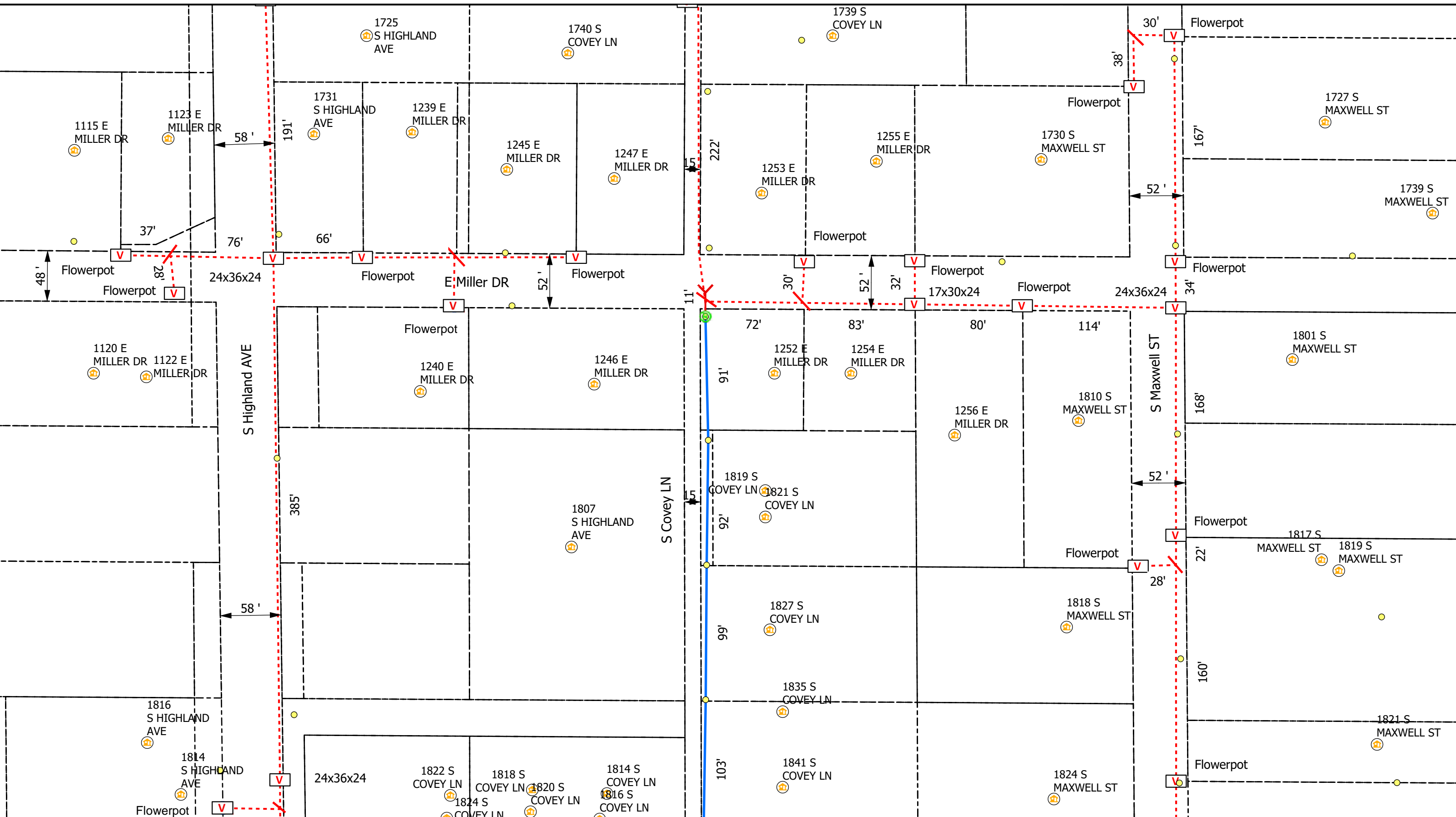

Legend

- Poles
- Vaults
- Overhead Strand
- Conduit
- Bloomington_Parcels
- Risers
- Address
- Anchor
- Sidewalk
- Grids

All Flowerpots 12" DIA



City of Bloomington, IN Permit:
Design View

INI	BY	DATE	DESCRIPTION



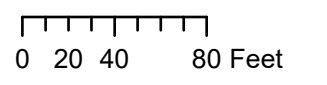
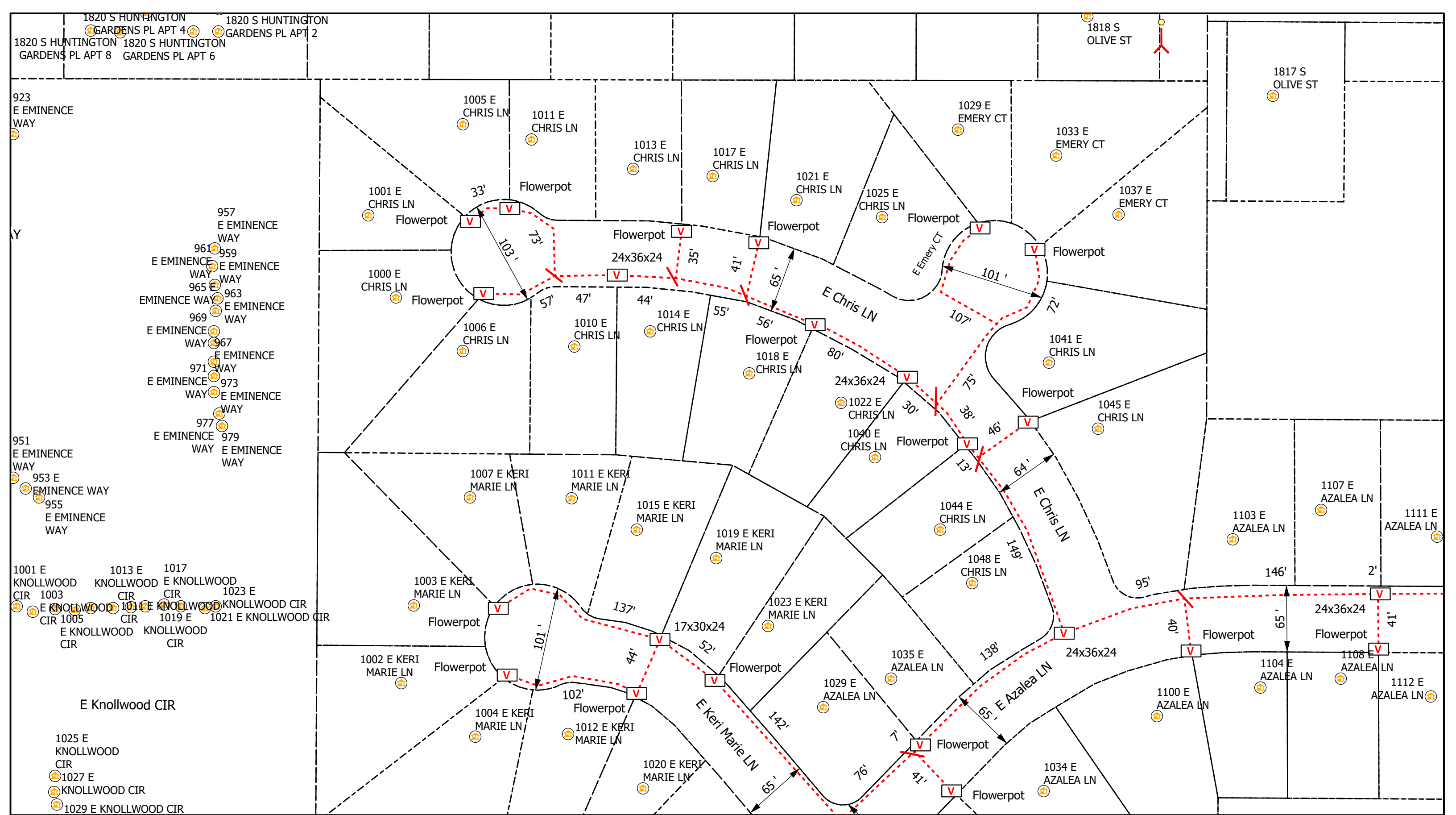

Legend

- Poles
- Vaults
- Overhead Strand
- Conduit
- Bloomington_Parcels
- Risers
- Address
- Anchor
- Sidewalk
- Grids

All Flowerpots 12" DIA



City of Bloomington, IN Permit:
Design View

INI	BY	DATE	DESCRIPTION



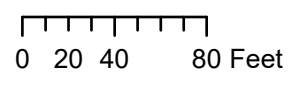
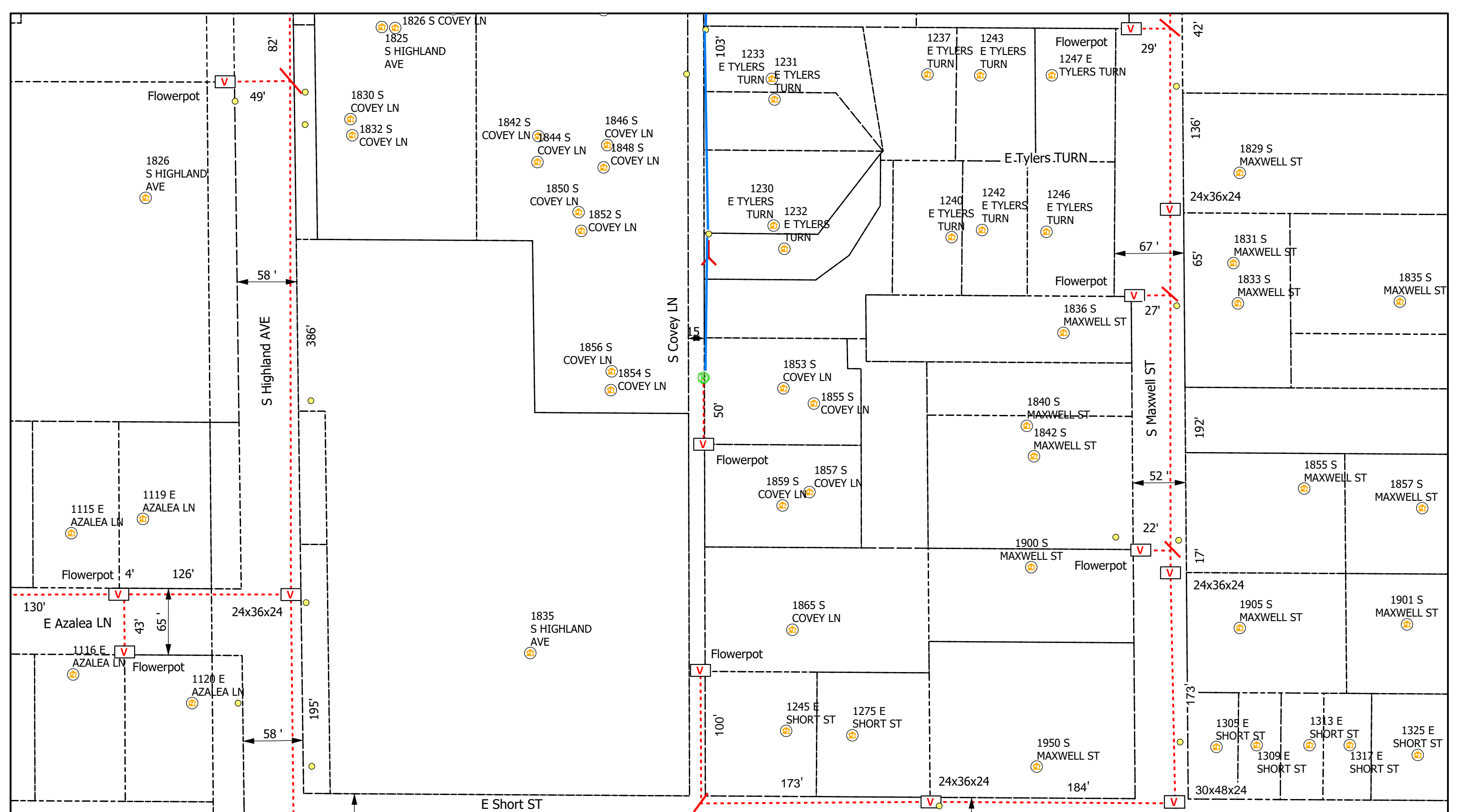

- Legend**
- Poles
 - V Vaults
 - Overhead Strand
 - Conduit
 - Bloomington_Parcels
 - R Risers
 - ⊕ Address
 - Y Anchor
 - ← Sidewalk
 - Grids

All Flowerpots 12" DIA



City of Bloomington, IN Permit:
Design View

INI	BY	DATE	DESCRIPTION



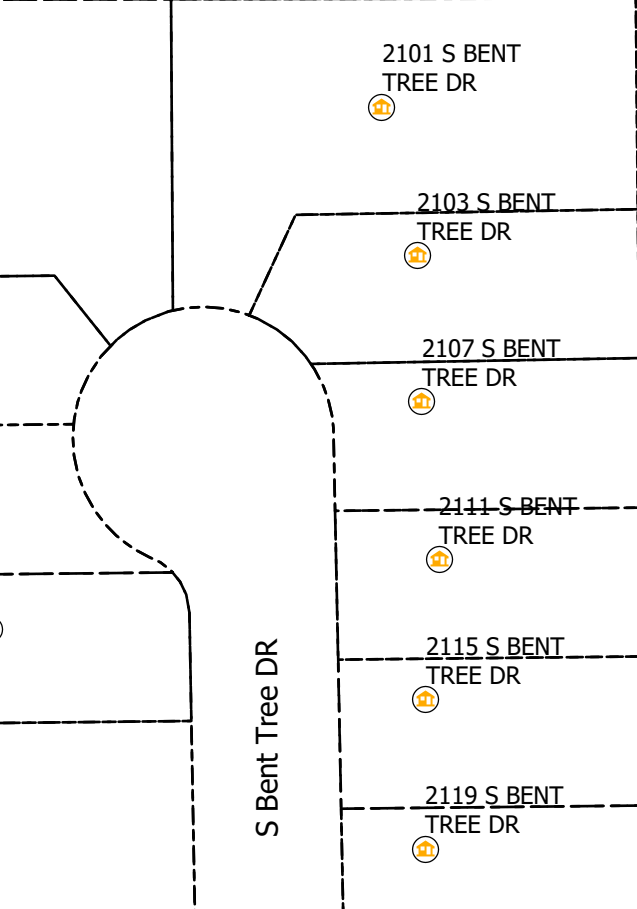
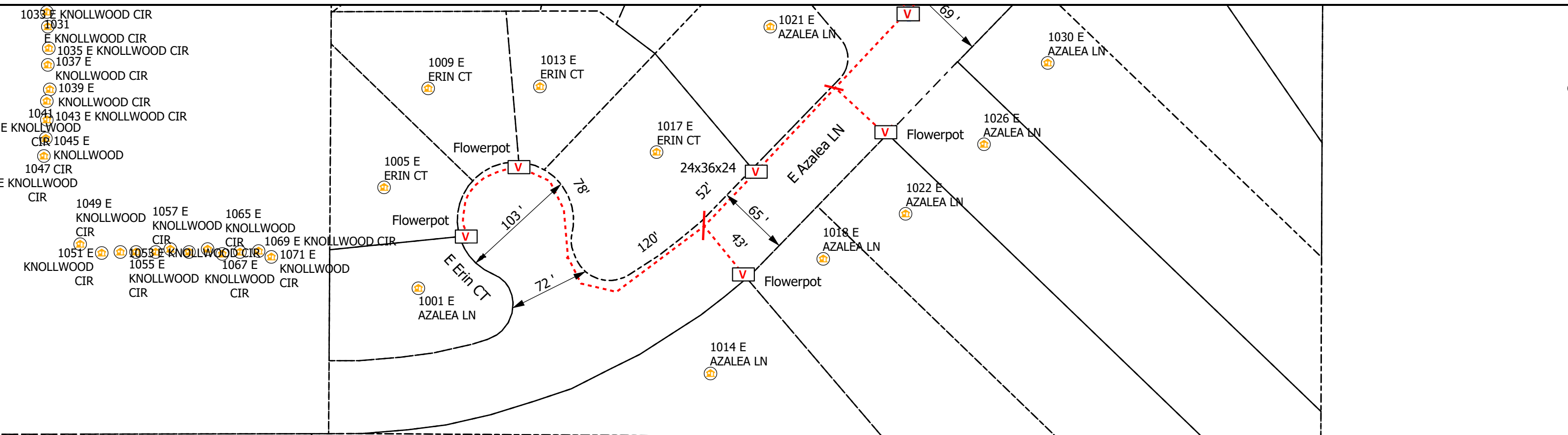

Legend

- Poles
- V Vaults
- Overhead Strand
- Conduit
- Bloomington_Parcels
- R Risers
- Ⓜ Address
- Y Anchor
- ← Sidewalk
- Grids

All Flowerpots 12" DIA



City of Bloomington, IN Permit:
Design View

INI	BY	DATE	DESCRIPTION

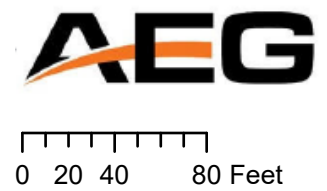

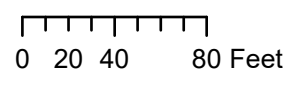
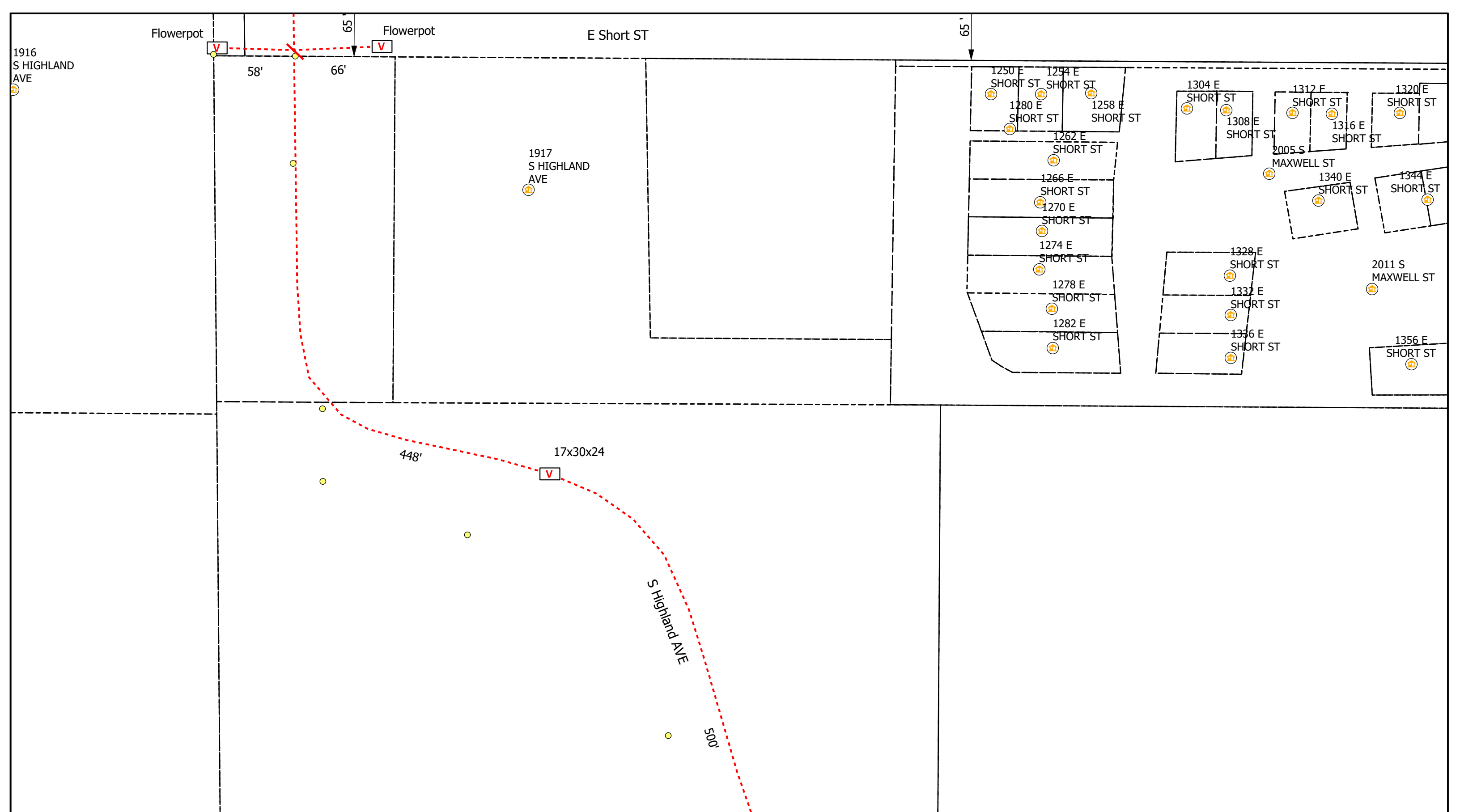

Legend

- Poles
- V Vaults
- Overhead Strand
- - - Conduit
- Bloomington_Parcels
- R Risers
- A Address
- Y Anchor
- ← Sidewalk
- Grids

All Flowerpots 12" DIA



City of Bloomington, IN Permit:
Design View

INI	BY	DATE	DESCRIPTION



2125
S HIGHLAND
AVE

2120
S HIGHLAND
AVE

V
Flowerpot











S Highland AVE

V
17x30x24

5A'

307'

Legend

-  Poles
-  Bloomington_Parcels
-  Anchor
-  Vaults
-  Risers
-  Sidewalk
-  Overhead Strand
-  Address
-  Grids
-  Conduit

All Flowerpots 12" DIA



City of Bloomington, IN Permit:
Design View

INI	BY	DATE	DESCRIPTION



0 20 40 80 Feet

Carlton® PV-Mold® Nonmetallic Pole Riser System

Carlton PV-Mold is a nonmetallic pole riser system designed to protect communications power cable installed on poles.

Features:

- Meets or exceeds requirements outlined in the National Electric Safety Code (NESC).
- Designed in accordance with NEMA TC-19 specifications.
- Ultraviolet, cold temperature and corrosive atmosphere resistant.
- Schedule 40 wall meets Schedule 80 PVC conduit impact requirements per NEMA TC-19.
- No grounding required.
- Belled end fits over each added section or conduit.
- Flame retardant.
- Requires no maintenance.
- PV-Mold acts as an insulator against electrical shock.
- Interchangeable parts and accessories to match the needs of specific requirements.



Steel U-Guard requires grounding strapping and does not have belled ends.



PV-Mold has belled ends, flanged design and does not require grounding.

Flanged Overall Length 10 Feet, Including Bell

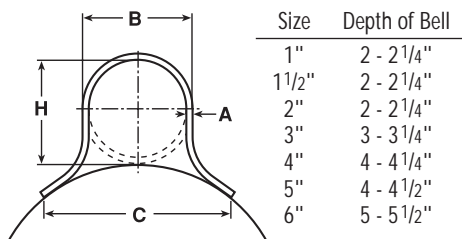

Slots are 1/2" from side to side, and allow for expansion and contraction.

Slot Dimensions: for sizes 2" through 6" are 5/16" wide, 3/4" long.

Slot Dimensions: for 1" and 1 1/2" are 3/16" wide, 3/4" long.

Slot Spacing: 18" from center, beginning 6" from end.

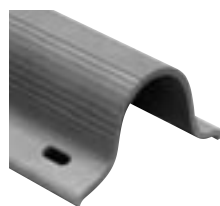

Standard Duty

Part No.	Size	Std. Ctn. Qty.	Std. Ctn. Wt. (lbs.)	Dimensions				Actual Impact @ 0°C 20 Pound Top
				A	B	C	H	
59208N	1"	294	1059	0.100"	1 5/8"	2 3/8"	1 5/8"	40 Ft.-Lbs.
59211N	2"	136	726	0.100"	2 3/8"	4 1/2"	2 3/8"	100 Ft.-Lbs.
59211X (5' length)	2"	136	363	0.100"	2 3/8"	4 1/2"	2 3/8"	100 Ft.-Lbs.
59213N	3"	66	761	0.150"	3 1/2"	6"	3 1/2"	110 Ft.-Lbs.
59213X (5' length)	3"	66	381	0.150"	3 1/2"	6"	3 1/2"	100 Ft.-Lbs.
59215N	4"	65	910	0.150"	4 1/2"	6 1/2"	4 1/2"	110 Ft.-Lbs.
59216N	5"	30	515	0.150"	5 1/2"	7 1/2"	5 1/2"	110 Ft.-Lbs.

Heavy Duty Schedule 40

59010N	1 1/2"	200	1142	0.145"	1 29/32"	3 1/2"	1 29/32"	100 Ft.-Lbs.
59011N	2"	136	1214	0.154"	2 3/8"	4 1/2"	2 3/8"	150 Ft.-Lbs.
59013N	3"	66	937	0.216"	3 1/2"	6"	3 9/32"	150 Ft.-Lbs.
59015N	4"	65	1621	0.237"	4 1/2"	6 1/2"	4 1/2"	260 Ft.-Lbs.
59015X (5' length)	4"	65	707	0.237"	4 1/2"	6 1/2"	4 1/2"	260 Ft.-Lbs.
59016N	5"	30	870	0.258"	5 1/2"	7 1/2"	5 1/2"	260 Ft.-Lbs.
59017N	6"	30	1160	0.280"	6 5/8"	8 3/4"	6 5/8"	260 Ft.-Lbs.

Extra Heavy Duty Schedule 80

59411N	2"	136	1549	0.218"	2 3/8"	4 1/2"	2 3/8"	300 Ft.-Lbs.
59413N	3"	66	1495	0.030"	3 1/2"	6"	3 1/2"	525 Ft.-Lbs.

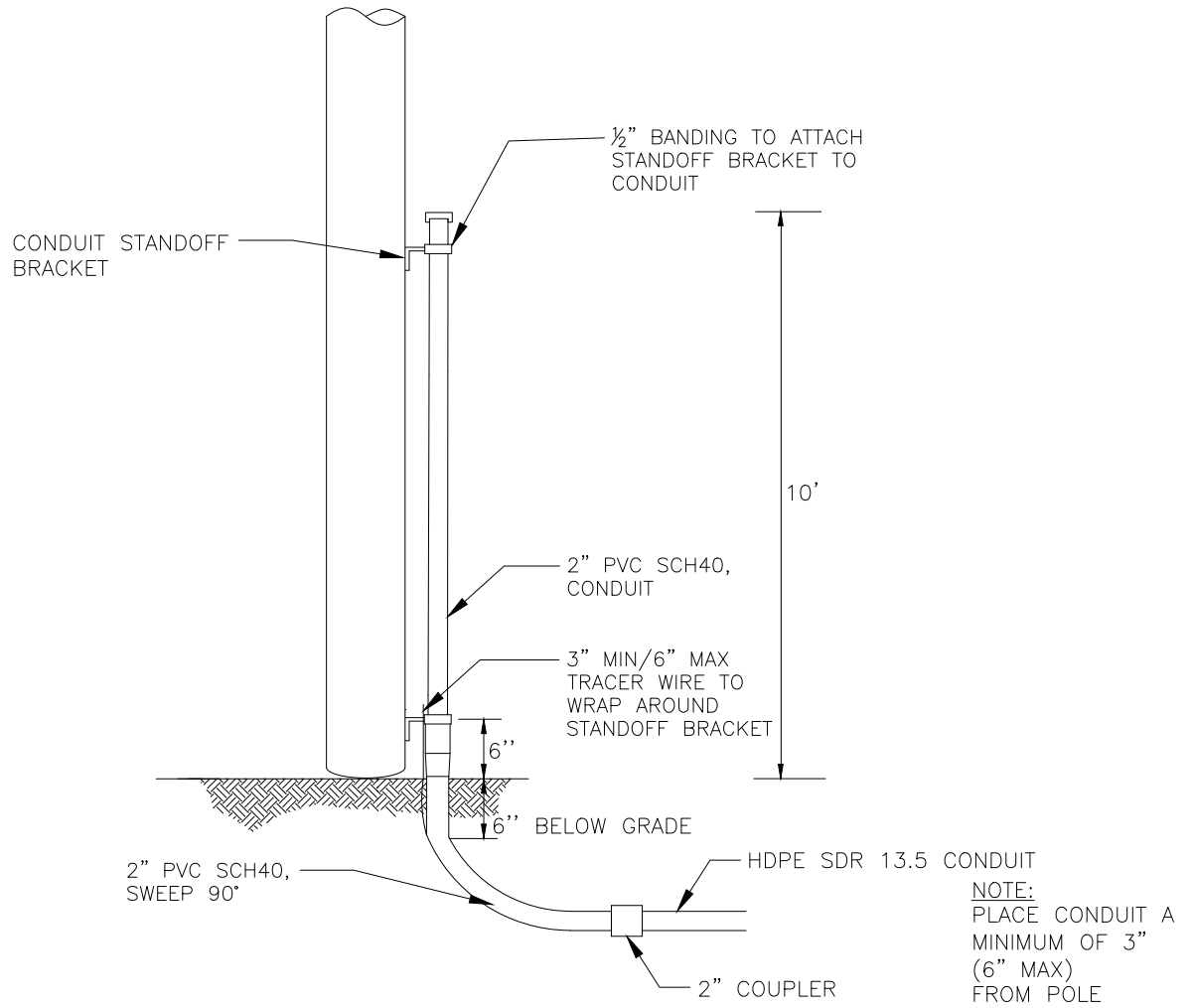

DESCRIPTION	QTY	MANUFACTURER (PREFERRED)	PART #
SCREW, LAG, 1/2" x 4-1/2"	10		
HDPE SDR 13.5 CONDUIT, VARIOUS SIZES	N/A		
2" PVC SCH40, RISER PIPE	1		
#12 TRACER WIRE	N/A		
2" PVC SCH40, SWEEP, 90 DEG	1		
CONDUIT STANDOFF BRACKET	VARIES		
CONDUIT STRAP KIT	VARIES		
2" COUPLER	1		



TYPICAL RISER
CONDUIT
WOOD POLE

(R2-W)

CONCEPTUAL SIDE VIEW

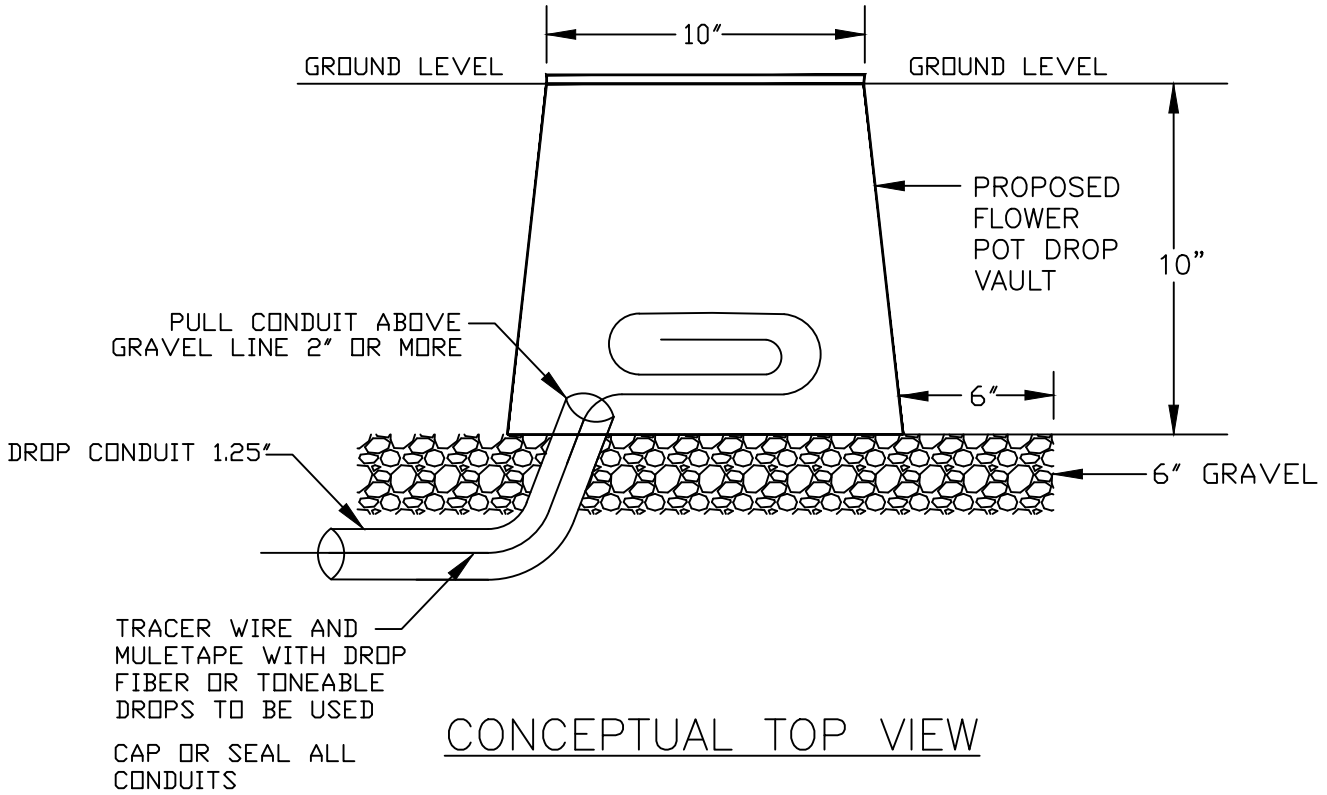

CONCEPTUAL TOP VIEW

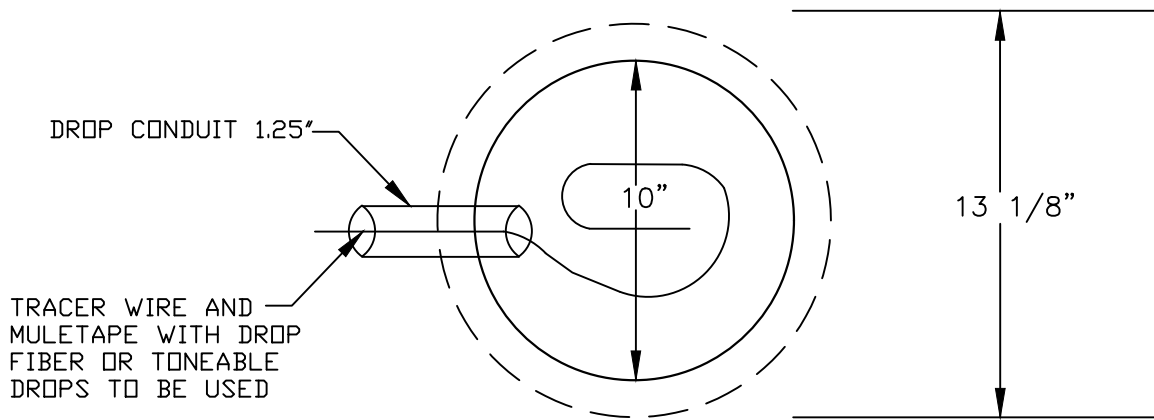

FLOWER POT

30"x48" PC UNIT, 2PC TIER 15/22
 18", 24", and 36" HEIGHT



AMERICAN POLYMER COMPANY

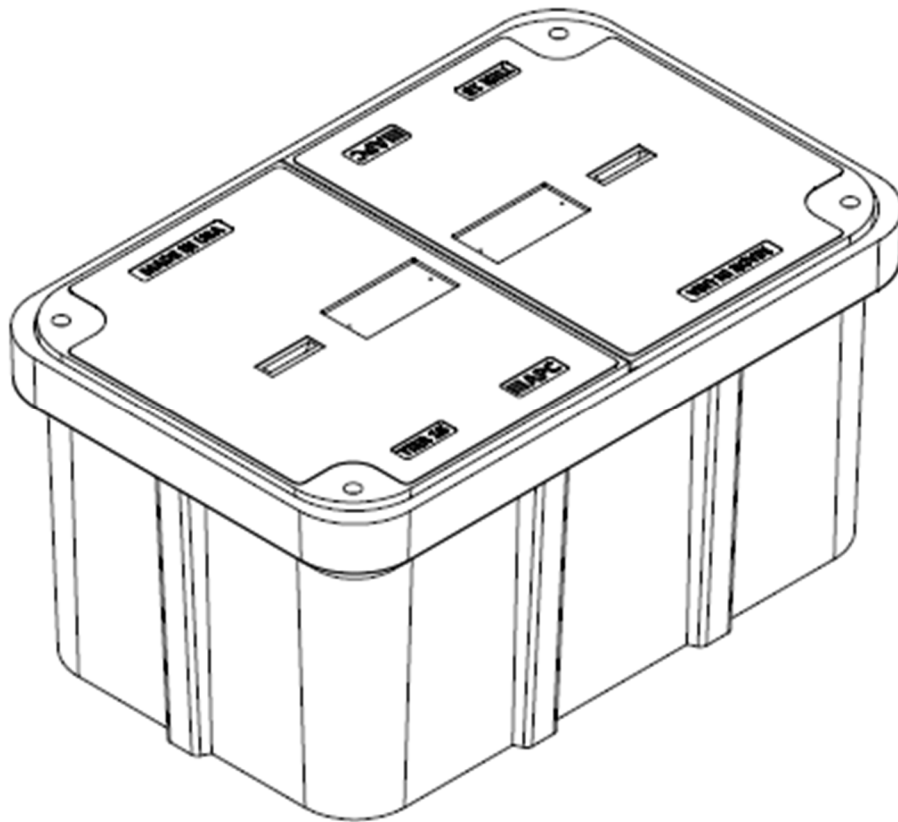

Description	Nominal Size	ANSI Tier	Part Number	Estimated Weight
PC Unit – TIER 15	30"x48"x18"	Tier 15	P304818HU15...	460 lbs.
PC Unit – TIER 22	30"x48"x18"	Tier 22	P304818HU22...	525 lbs.
PC Unit – TIER 15	30"x48"x24"	Tier 15	P304824HU15...	510 lbs.
PC Unit – TIER 22	30"x48"x24"	Tier 22	P304824HU22...	575 lbs.
PC Unit – TIER 15	30"x48"x36"	Tier 15	P304836HU15...	615 lbs.
PC Unit – TIER 22	30"x48"x36"	Tier 22	P304836HU22...	680 lbs.



30"x48" PC UNIT, 2PC TIER 15/22

18", 24", and 36" HEIGHT



AMERICAN POLYMER COMPANY

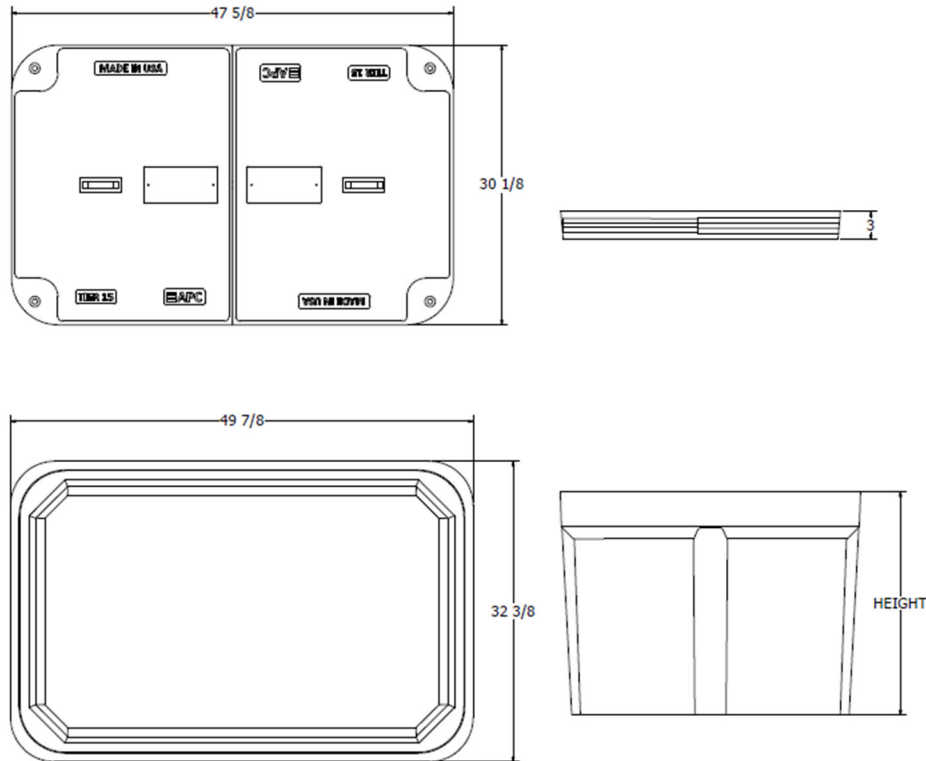

Components	Nominal Size	ANSI Tier	Part Number	Estimated Weight
Replacement Box	30"x48"x18"	Tier 22	P304818B22	185 lbs.
Replacement Box	30"x48"x24"	Tier 22	P304824B22	235 lbs.
Replacement Box	30"x48"x36"	Tier 22	P304836B22	340 lbs.
Replacement Lids - T15	30"x48" (half)	Tier 15	Various	150 lbs.
Replacement Lids - T22	30"x48" (half)	Tier 22	Various	170 lbs.

Bolt options



Machine Thread



Auger Thread



24"x36" PC UNIT, TIER 15/22
 18", 24", 30", and 36" HEIGHT



AMERICAN POLYMER COMPANY

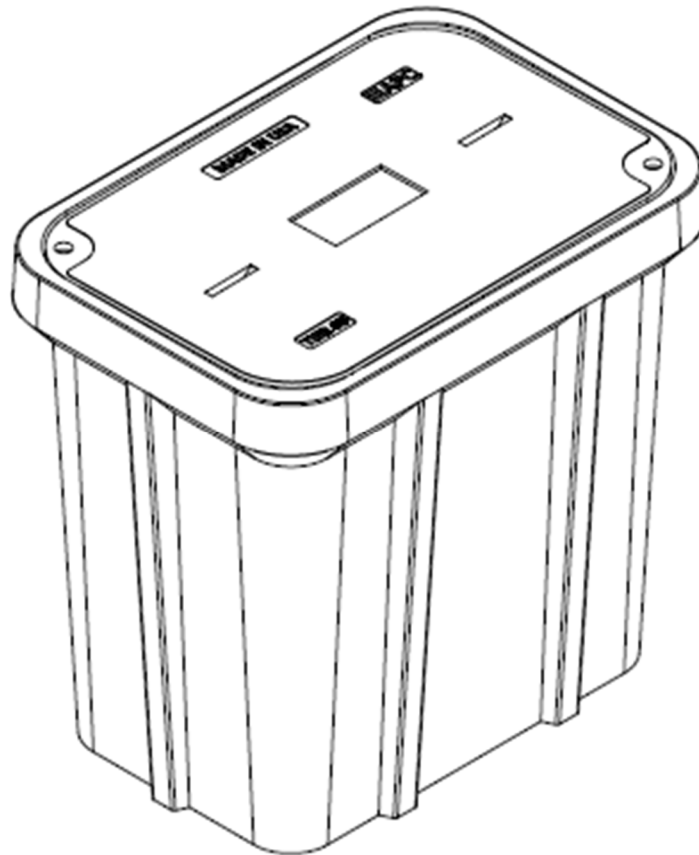

Description	Nominal Size	ANSI Tier	Part Number	Estimated Weight
PC Unit – TIER 15	24x36"x18"	Tier 15	P243618U15...	335 lbs.
PC Unit – TIER 22	24x36"x18"	Tier 22	P243618U22...	355 lbs.
PC Unit – TIER 15	24x36"x24"	Tier 15	P243624U15...	365 lbs.
PC Unit – TIER 22	24x36"x24"	Tier 22	P243624U22...	385 lbs.
PC Unit – TIER 15	24x36"x30"	Tier 15	P243630U15...	395 lbs.
PC Unit – TIER 22	24x36"x30"	Tier 22	P243630U22...	415 lbs.
PC Unit – TIER 15	24x36"x36"	Tier 15	P243636U15...	425 lbs.
PC Unit – TIER 22	24x36"x36"	Tier 22	P243636U22...	445 lbs.



24"x36" PC UNIT, TIER 15/22

18", 24", 30", and 36" HEIGHT



AMERICAN POLYMER COMPANY

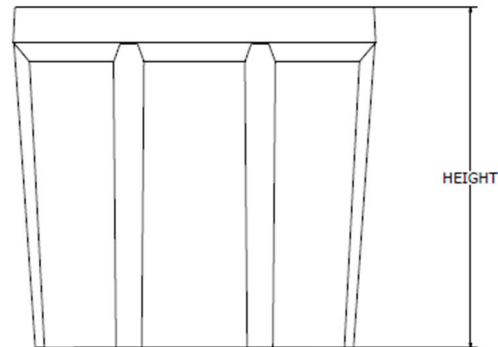
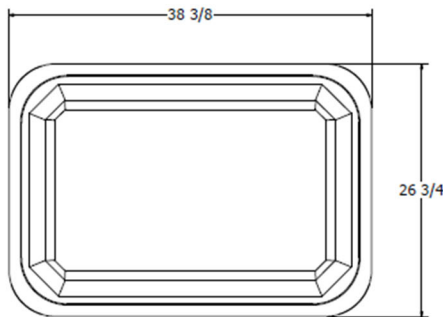
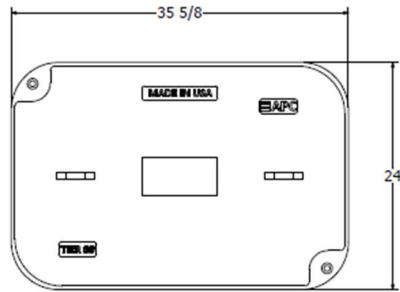

Components	Nominal Size	ANSI Tier	Part Number	Estimated Weight
Replacement Box	24"x36"x18"	Tier 22	P243618B22	165 lbs.
Replacement Box	24"x36"x24"	Tier 22	P243624B22	195 lbs.
Replacement Box	24"x36"x30"	Tier 22	P243630B22	225 lbs.
Replacement Box	24"x36"x36"	Tier 22	P243636B22	255 lbs.
Replacement Lids - T15	24"x36"	Tier 15	Various	170 lbs.
Replacement Lids - T22	24"x36"	Tier 22	Various	190 lbs.

Bolt options

Hex Head



Machine Thread



Penta Head



Auger Thread



17"x30" PC UNIT, TIER 15/22

12", 18", 24", and 30" HEIGHT



AMERICAN POLYMER COMPANY

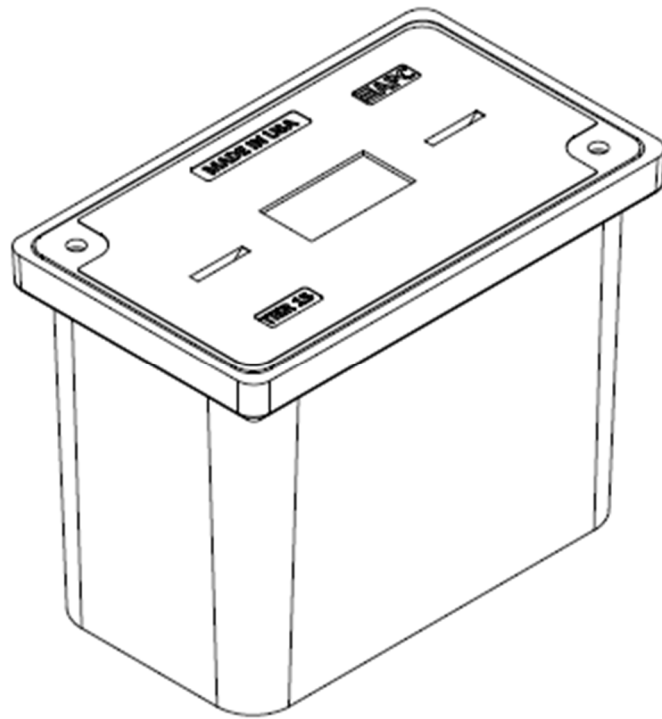

Description	Nominal Size	ANSI Tier	Part Number	Estimated Weight
PC Unit – TIER 15	17"x30"x12"	Tier 15	P173012U15...	138 lbs.
PC Unit – TIER 22	17"x30"x12"	Tier 22	P173012U22...	147 lbs.
PC Unit – TIER 15	17"x30"x18"	Tier 15	P173018U15...	172 lbs.
PC Unit – TIER 22	17"x30"x18"	Tier 22	P173018U22...	181 lbs.
PC Unit – TIER 15	17"x30"x24"	Tier 15	P173024U15...	192 lbs.
PC Unit – TIER 22	17"x30"x24"	Tier 22	P173024U22...	201 lbs.
PC Unit – TIER 15	17"x30"x30"	Tier 15	P173030U15...	217 lbs.
PC Unit – TIER 22	17"x30"x30"	Tier 22	P173030U22...	226 lbs.



17"x30" PC UNIT, TIER 15/22

12", 18", 24", and 30" HEIGHT



AMERICAN POLYMER COMPANY

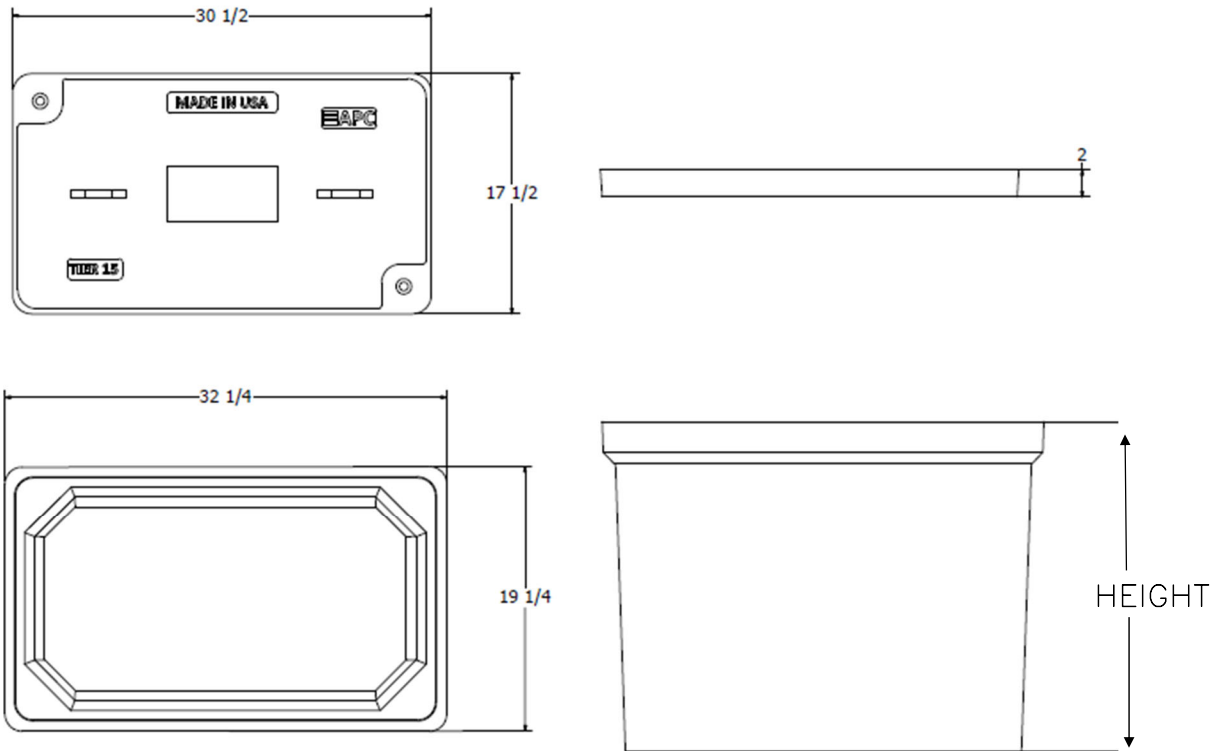

Components	Nominal Size	ANSI Tier	Part Number	Estimated Weight
Replacement Box	17"x30"x12"	Tier 22	P173012B22	66 lbs.
Replacement Box	17"x30"x18"	Tier 22	P173018B22	100 lbs.
Replacement Box	17"x30"x24"	Tier 22	P173024B22	120 lbs.
Replacement Box	17"x30"x30"	Tier 22	P173030B22	145 lbs.
Replacement Lids – T15	17"x30"	Tier 15	Various	72 lbs.
Replacement Lids – T22	17"x30"	Tier 22	Various	81 lbs.

Bolt options



Machine Thread



Auger Thread



33"x60" PC UNIT, 2PC TIER 15/22
36" HEIGHT



AMERICAN POLYMER COMPANY

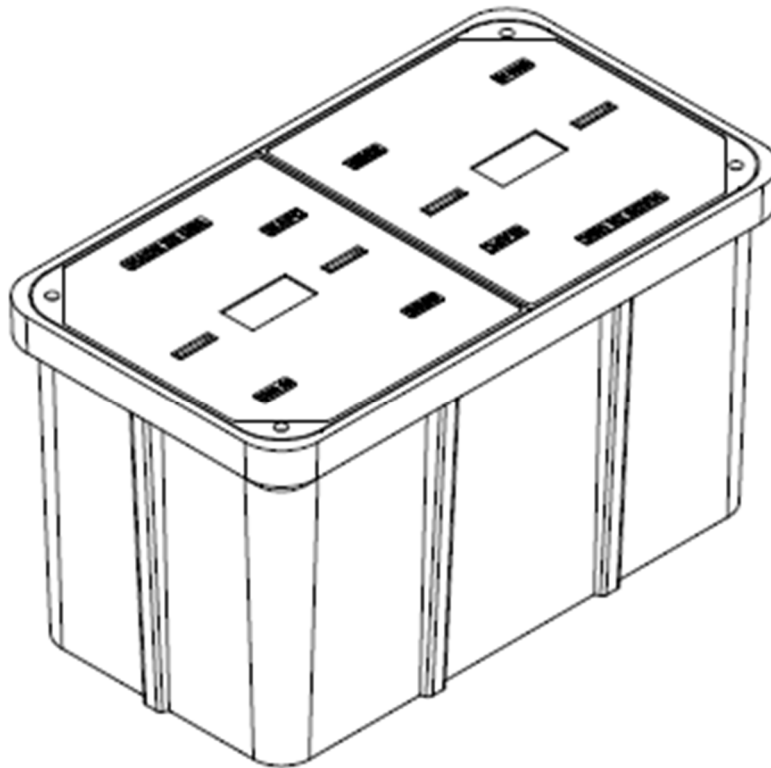

Description	Nominal Size	ANSI Tier	Part Number	Estimated Weight
PC Unit - TIER 15	33"x60"x36"	Tier 15	P336036U15...	930 lbs.
PC Unit - TIER 22	33"x60"x36"	Tier 22	P336036U22...	1030 lbs.



33"x60" PC UNIT, 2PC TIER 15/22

36" HEIGHT



AMERICAN POLYMER COMPANY

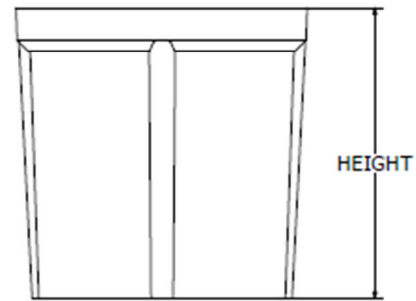
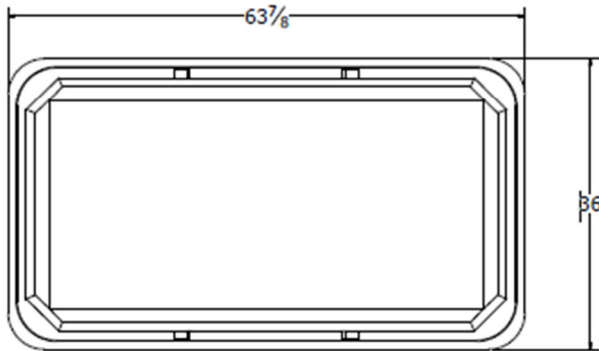
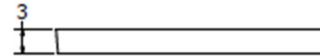

Components	Nominal Size	ANSI Tier	Part Number	Estimated Weight
Replacement Box	33"x60"x36"	Tier 22	P336036B22	530 lbs.
Replacement Lids - T15	33"x60" (half)	Tier 15	Various	200 lbs.
Replacement Lids - T22	33"x60" (half)	Tier 22	Various	250 lbs.

Bolt options

Hex Head



Machine Thread



Penta Head



Auger Thread



Speed (MPH) Prior To Road Work	SIGN SPACING, FT.		BUFFER SPACE, FT.	TAPER LENGTH, FT.		CHANNELIZING SPACING, FT.	
	Non-Divided Highways	Divided Highways	Length	Shoulder (10 ft. Width)	Lane (12 ft. Width)	Through Taper	Through Buffer/Work Area
	0-35	200	200	250	70	245	35
40-45	350	500	360	150	540	40	80
50-55	500	1000	495	185	660	50	100
60-70	SA-1000, SB-1500, SC-2640		730	235	840	60	120
Urban Low Speed - 100 FT							

APPROVED/ACCEPTED BY:
ENGINEER, OWNER, or PRIME CONTRACTOR
 Check for Notice to Proceed.
BLC02a-F14_S Maxwell St -TCP1

Signature: _____

Company: _____



Date: 1/18/2023 Project: BLC02a-F14 S Maxwell St -TCP :
: Traffic Control Suggestion For: AEG :
By: Road Runner Safety Services, Inc. : Nathan

Comments:
Drawing not to scale. Traffic control plan must be approved by an engineer. This is a suggestion only. Road Runners Safety Services, Inc. has no liability for this suggested traffic control plan. Actual placement and spacing of all traffic control devices will depend on field conditions and must conform to MUTCD standards.

- Legend**
- ADA Barricade
 - Channelizer
 - Conduit
 - Flagger (Person)
 - Overhead Strand
 - Sign
 - Vault
 - Work Area

Sheet 1

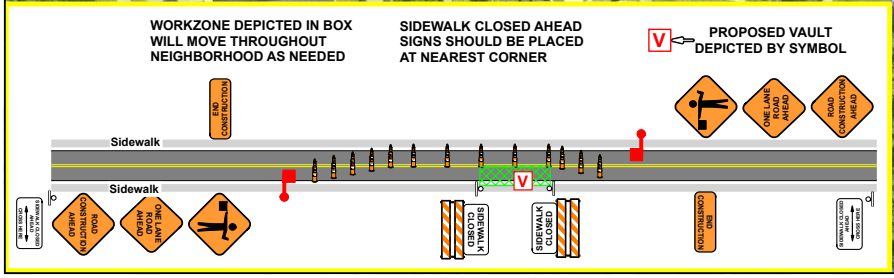

Sheet 2

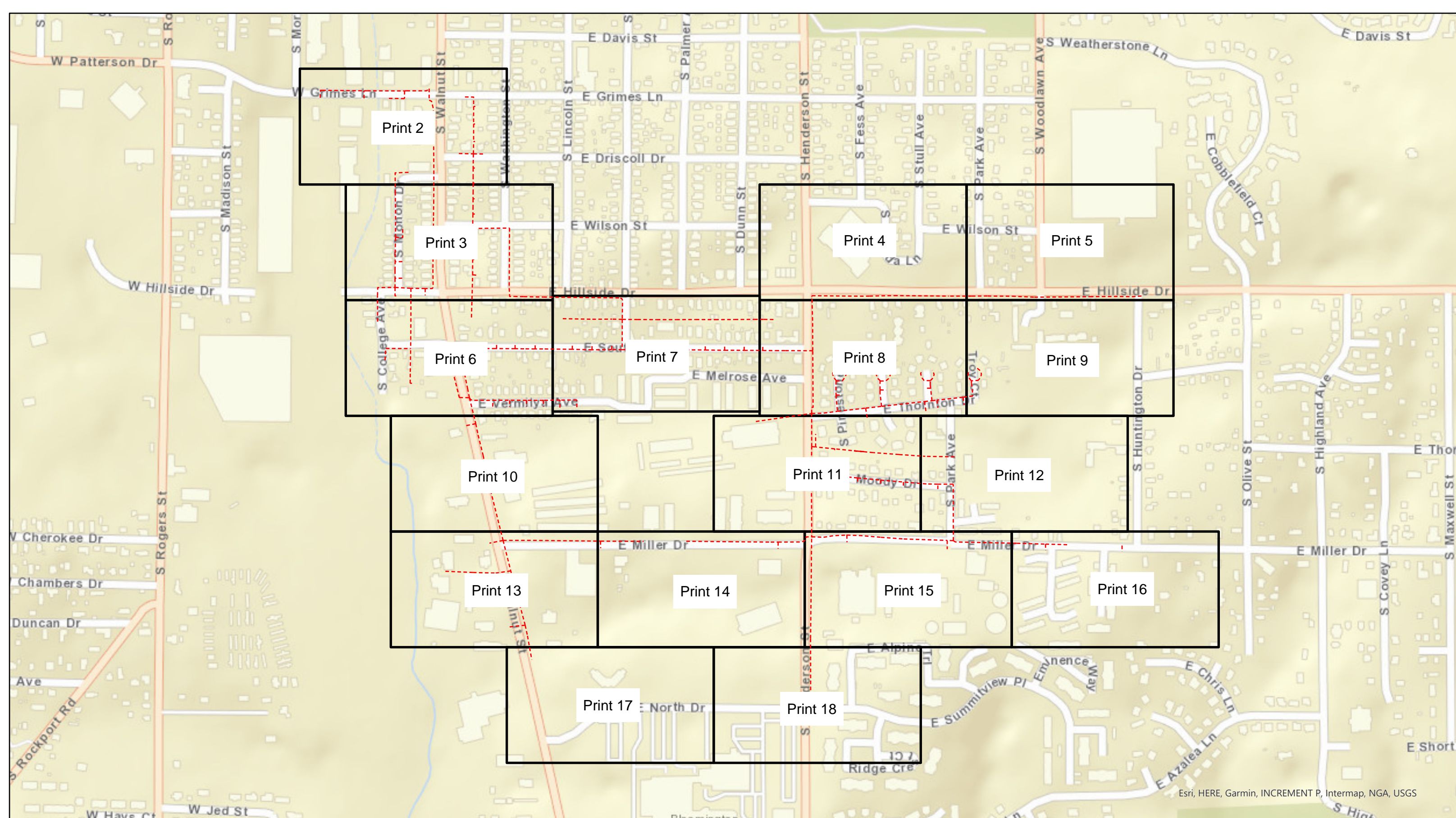

Esri, HERE, Garmin, INCREMENT P, Intermap, NGA, USGS



Legend BLC02a-F07_E Moody Dr

- Proposed Aerial
- - - Conduit
- Grids



City of Bloomington, IN Permit:
Design View

INI	BY	DATE	DESCRIPTION



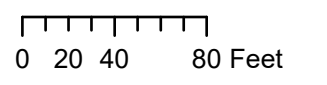
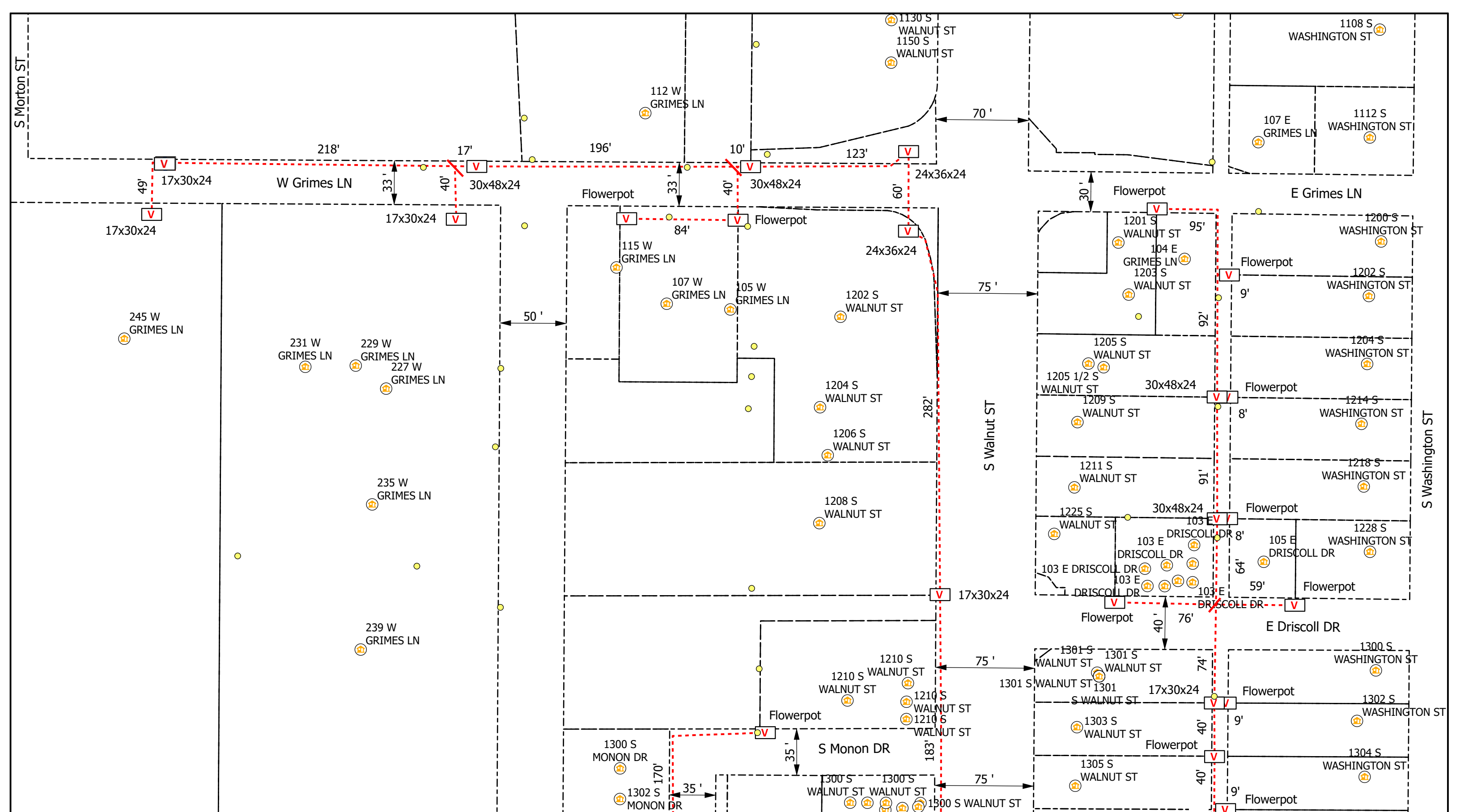

Legend

- Poles
- Ⓡ Risers
- Ⓜ Sidewalk
- V Vaults
- Overhead Strand
- Conduit
- Ⓜ Address
- Y Anchor
- Bloomington_Parcels
- Grids

All Flowerpots 12" DIA



City of Bloomington, IN Permit:
Design View

INI	BY	DATE	DESCRIPTION



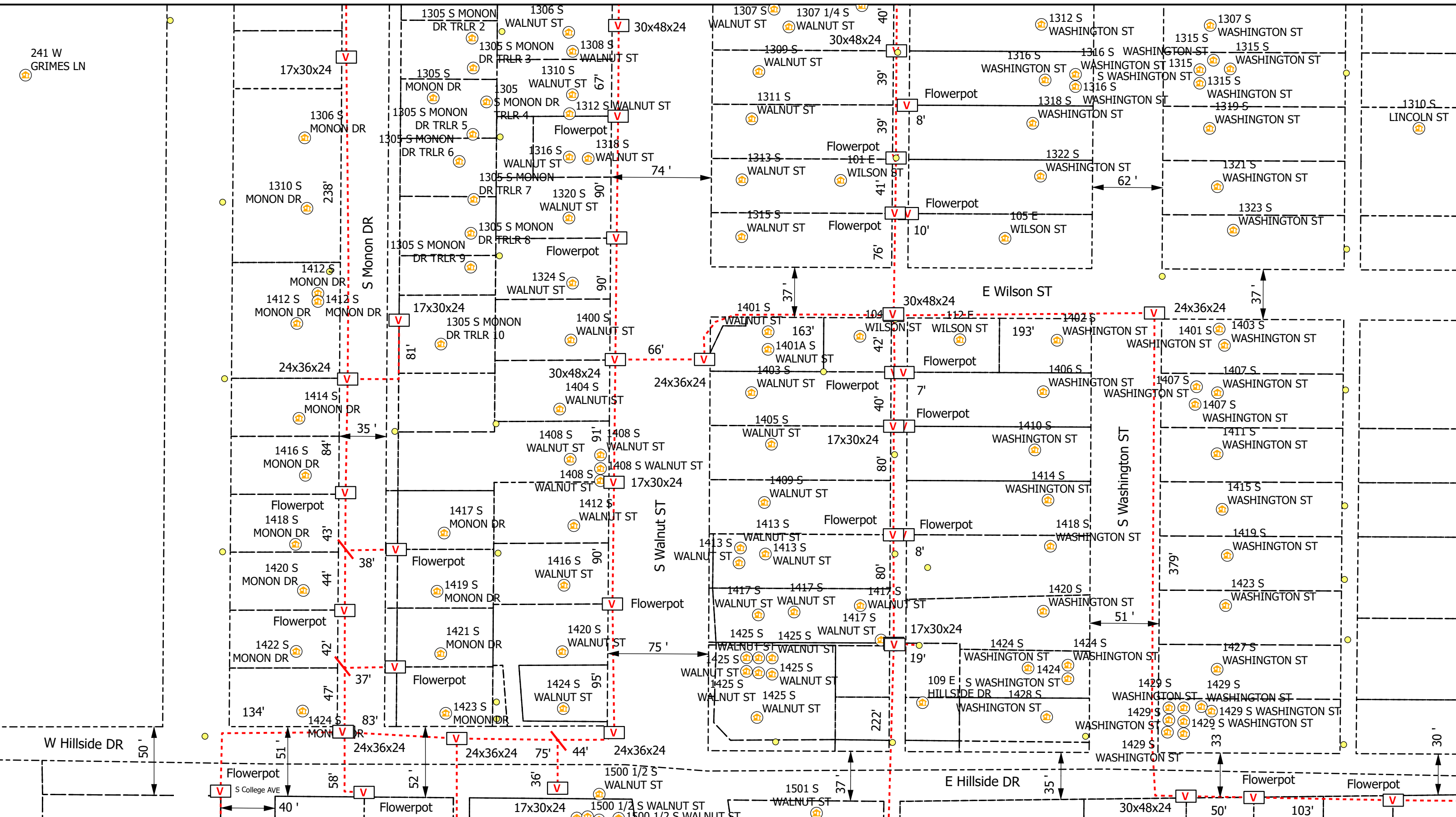

Legend

- Poles
- Risers
- Sidewalk
- Vaults
- Address
- Bloomington_Parcels
- Overhead Strand
- Anchor
- Grids
- Conduit

All Flowerpots 12" DIA

N

City of Bloomington, IN Permit:
Design View

INI	BY	DATE	DESCRIPTION

Print 3 of 18

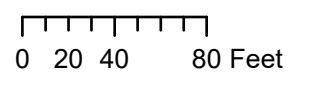
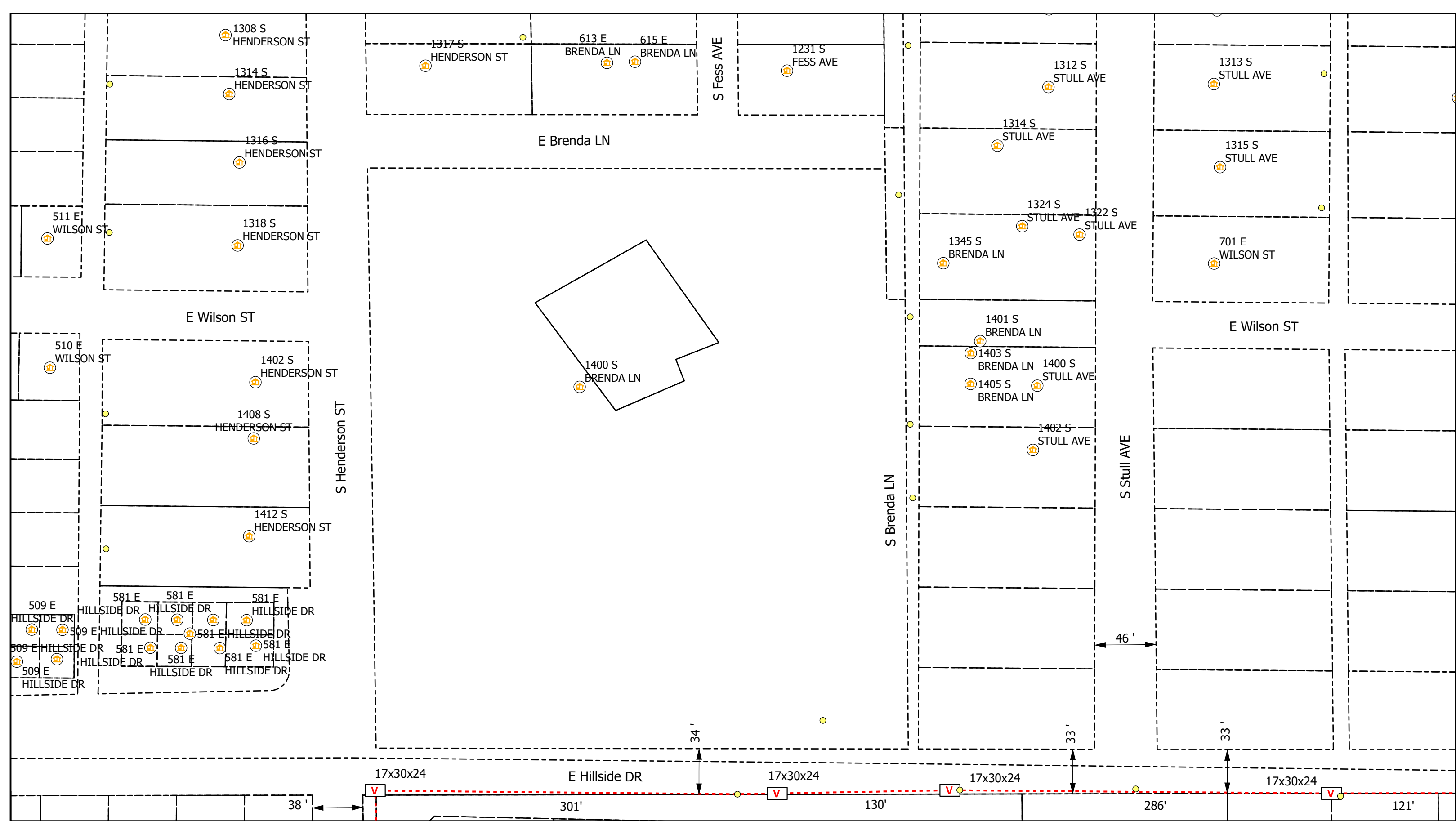

Legend

- Poles
- V Vaults
- Overhead Strand
- - - Conduit
- Ⓡ Risers
- Ⓜ Address
- Y Anchor
- ↖ Sidewalk
- Bloomington_Parcels
- Grids

All Flowerpots 12" DIA



City of Bloomington, IN Permit:
Design View

INI	BY	DATE	DESCRIPTION



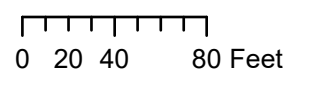
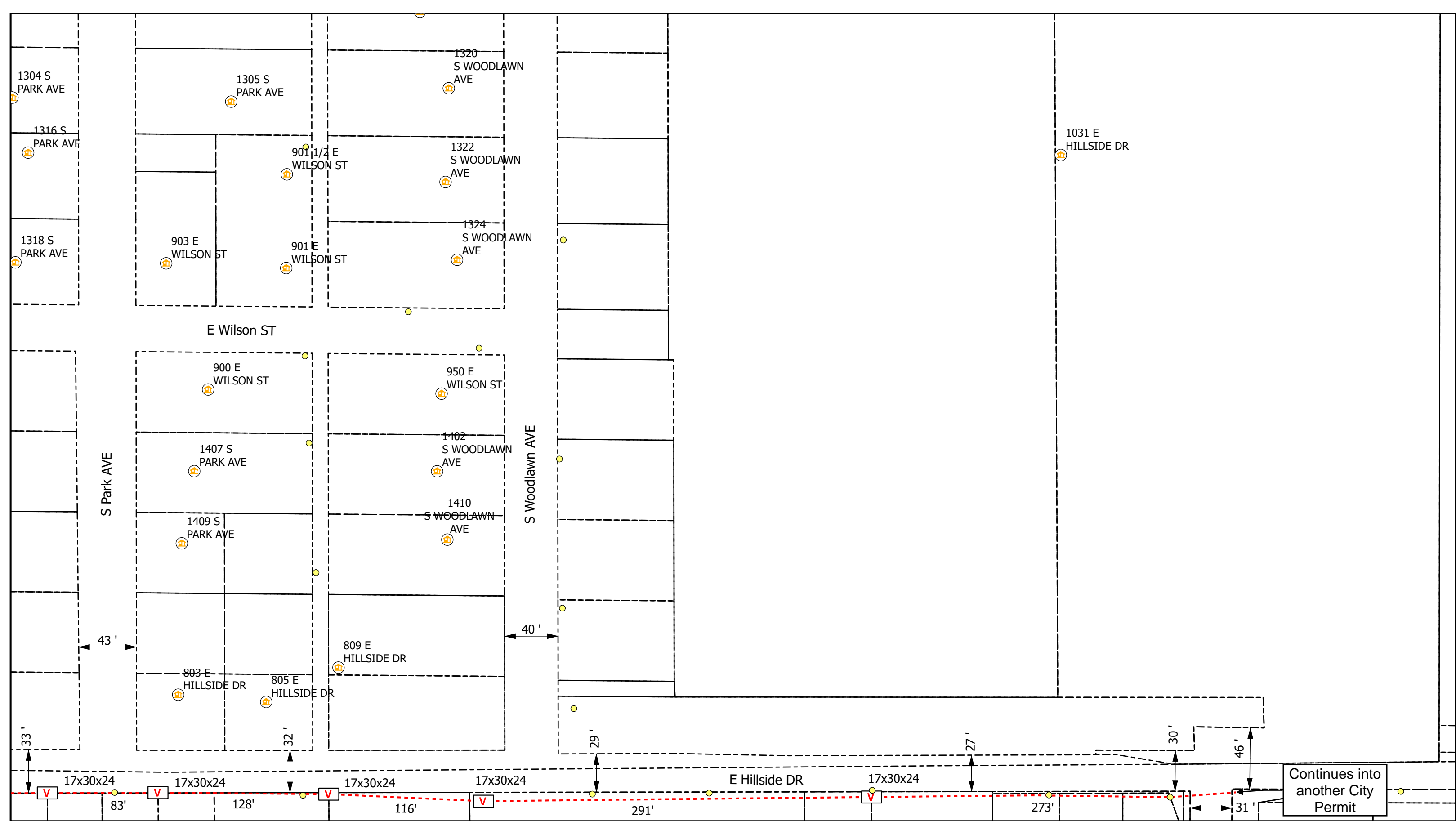

Legend

- Poles
- V Vaults
- Overhead Strand
- Conduit
- Ⓡ Risers
- 🏠 Address
- Y Anchor
- ↖ Sidewalk
- Bloomington_Parcels
- Grids

All Flowerpots 12" DIA



City of Bloomington, IN Permit:
Design View

INI	BY	DATE	DESCRIPTION



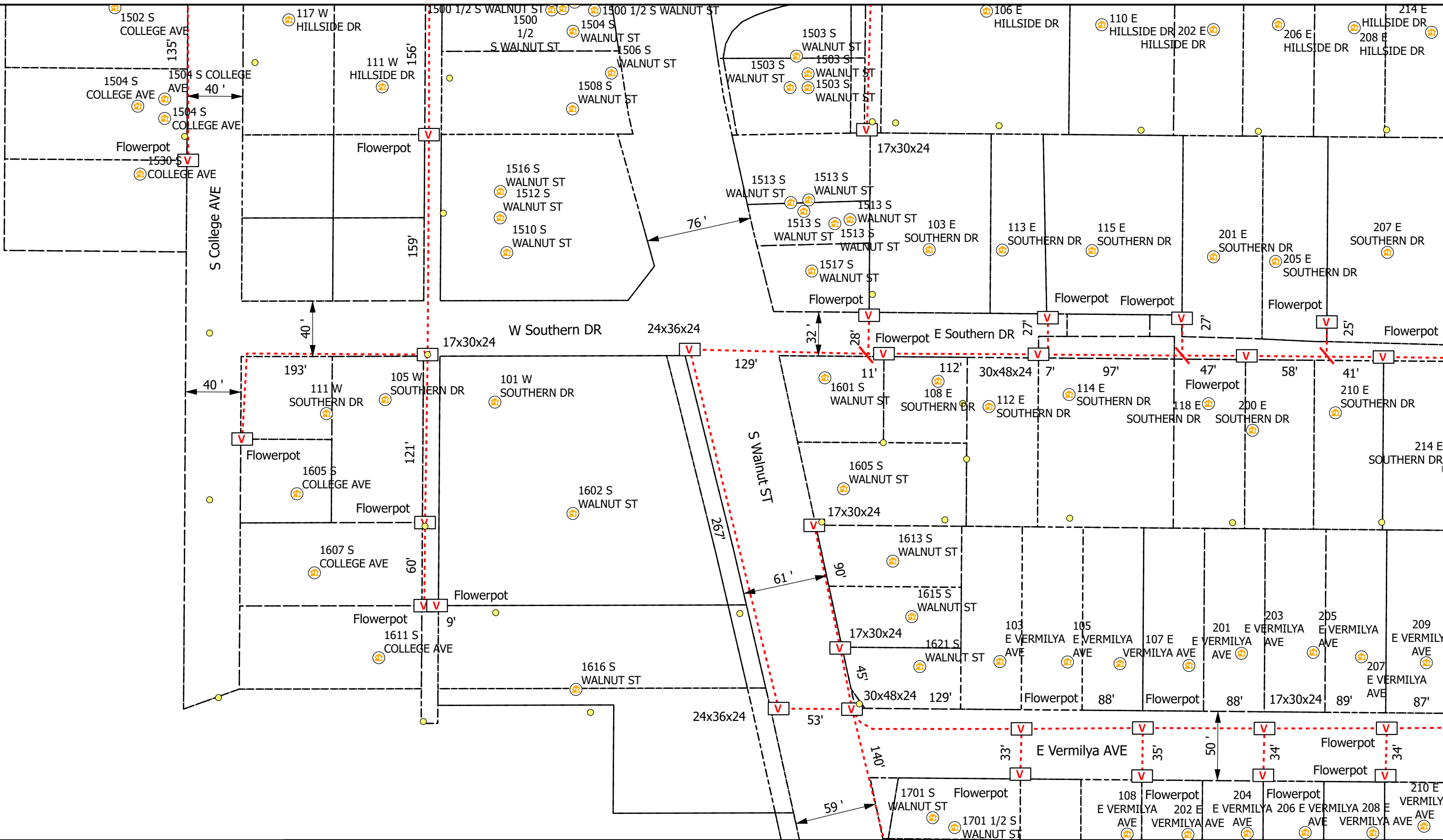

Legend

- Poles
- Risers
- Sidewalk
- Vaults
- Address
- Bloomington_Parcels
- Overhead Strand
- Anchor
- Grids
- Conduit

All Flowerpots 12" DIA

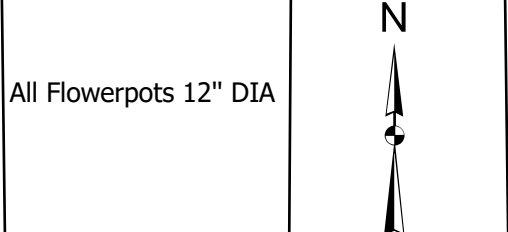

City of Bloomington, IN Permit:
Design View

INI	BY	DATE	DESCRIPTION

Print 6 of 18

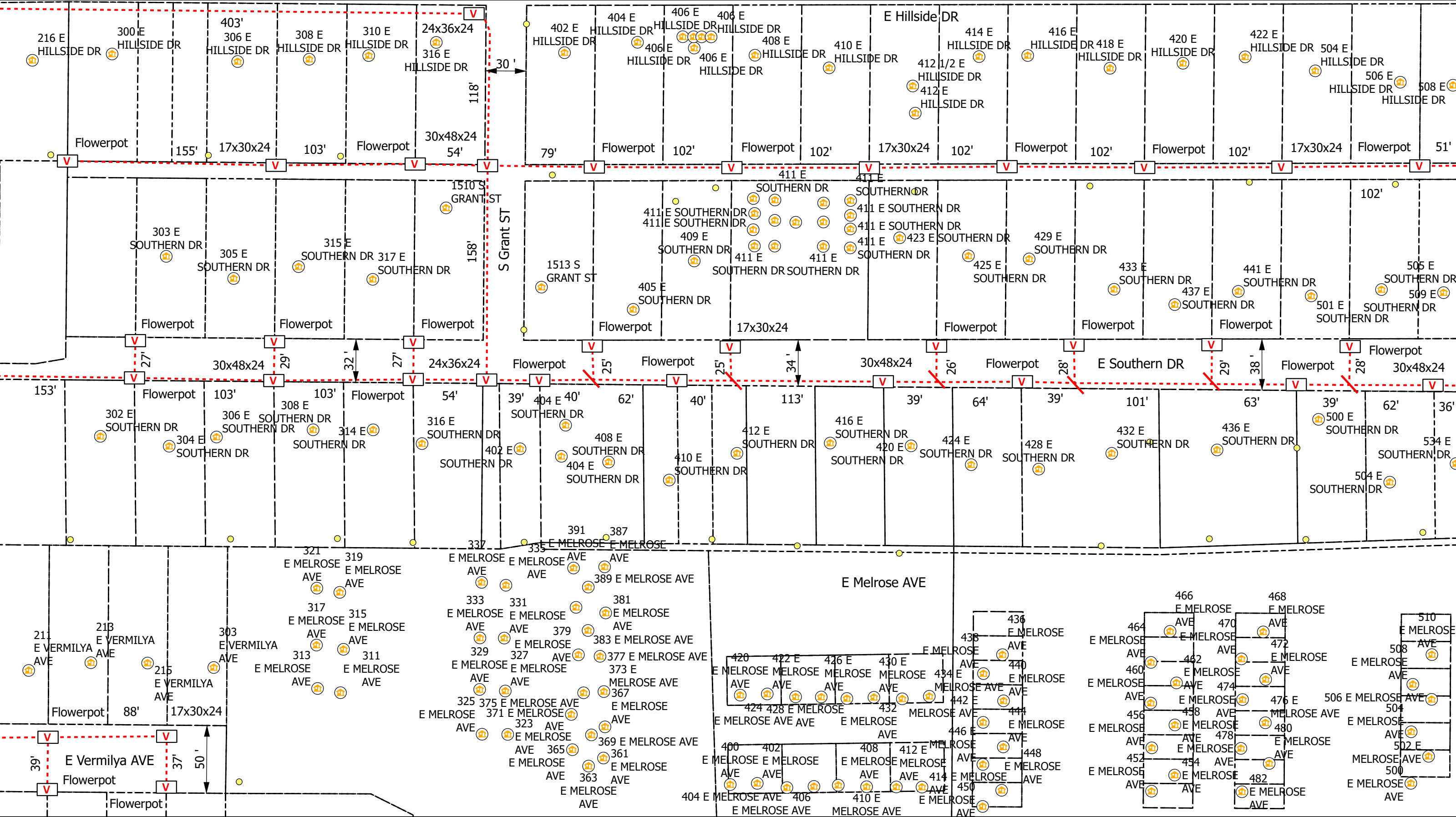

0 20 40 80 Feet

Legend

- Poles
- ⊗ Risers
- ⬆ Sidewalk
- V Vaults
- 🏠 Address
- Bloomington_Parcels
- Overhead Strand
- Y Anchor
- Grids
- - - Conduit

All Flowerpots 12" DIA

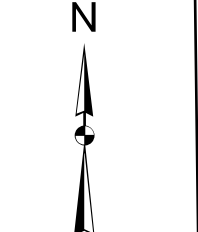

City of Bloomington, IN Permit:
Design View

INI	BY	DATE	DESCRIPTION

Print 7 of 18

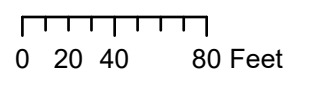
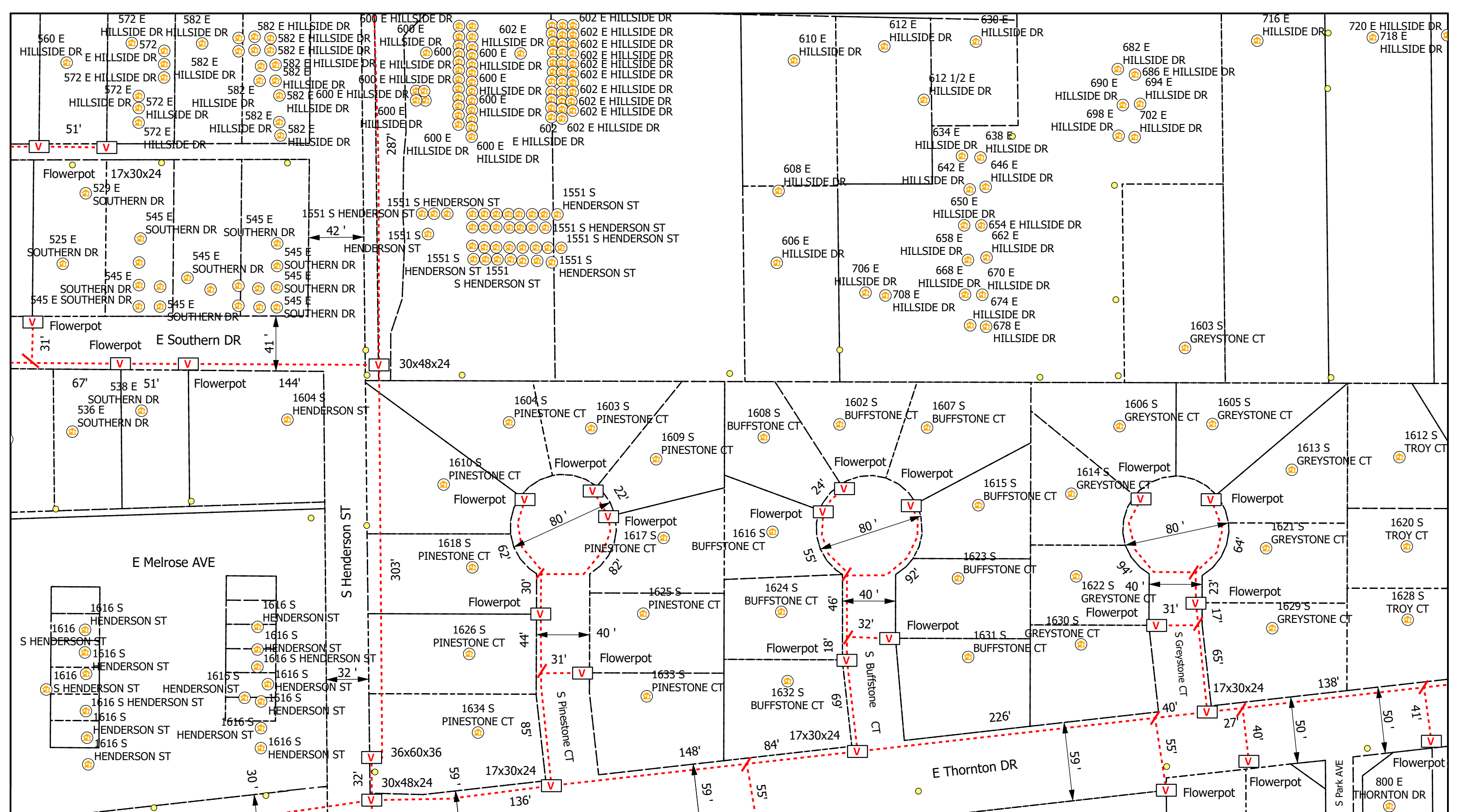

Legend

- Poles
- V Vaults
- Overhead Strand
- - - Conduit
- ⊕ Risers
- Ⓜ Address
- Y Anchor
- ↖ Sidewalk
- Bloomington_Parcels
- Grids

All Flowerpots 12" DIA



City of Bloomington, IN Permit:
Design View

INI	BY	DATE	DESCRIPTION



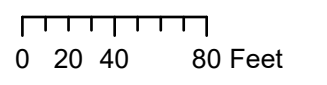
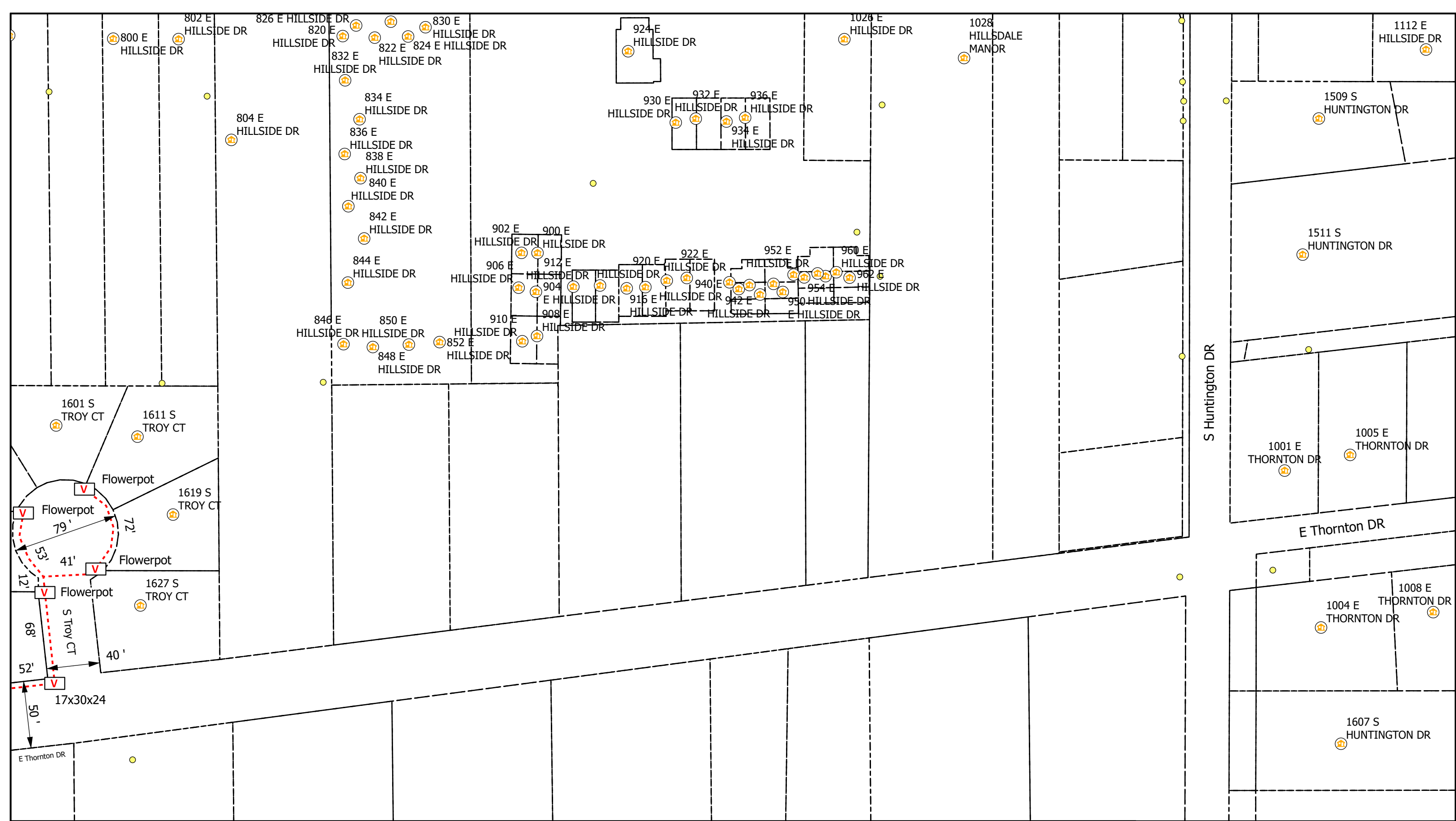

Legend

- Poles
- V Vaults
- Overhead Strand
- Conduit
- R Risers
- A Address
- Y Anchor
- └─ Sidewalk
- Bloomington_Parcels
- Grids

All Flowerpots 12" DIA



City of Bloomington, IN Permit:
Design View

INI	BY	DATE	DESCRIPTION



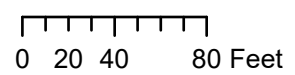
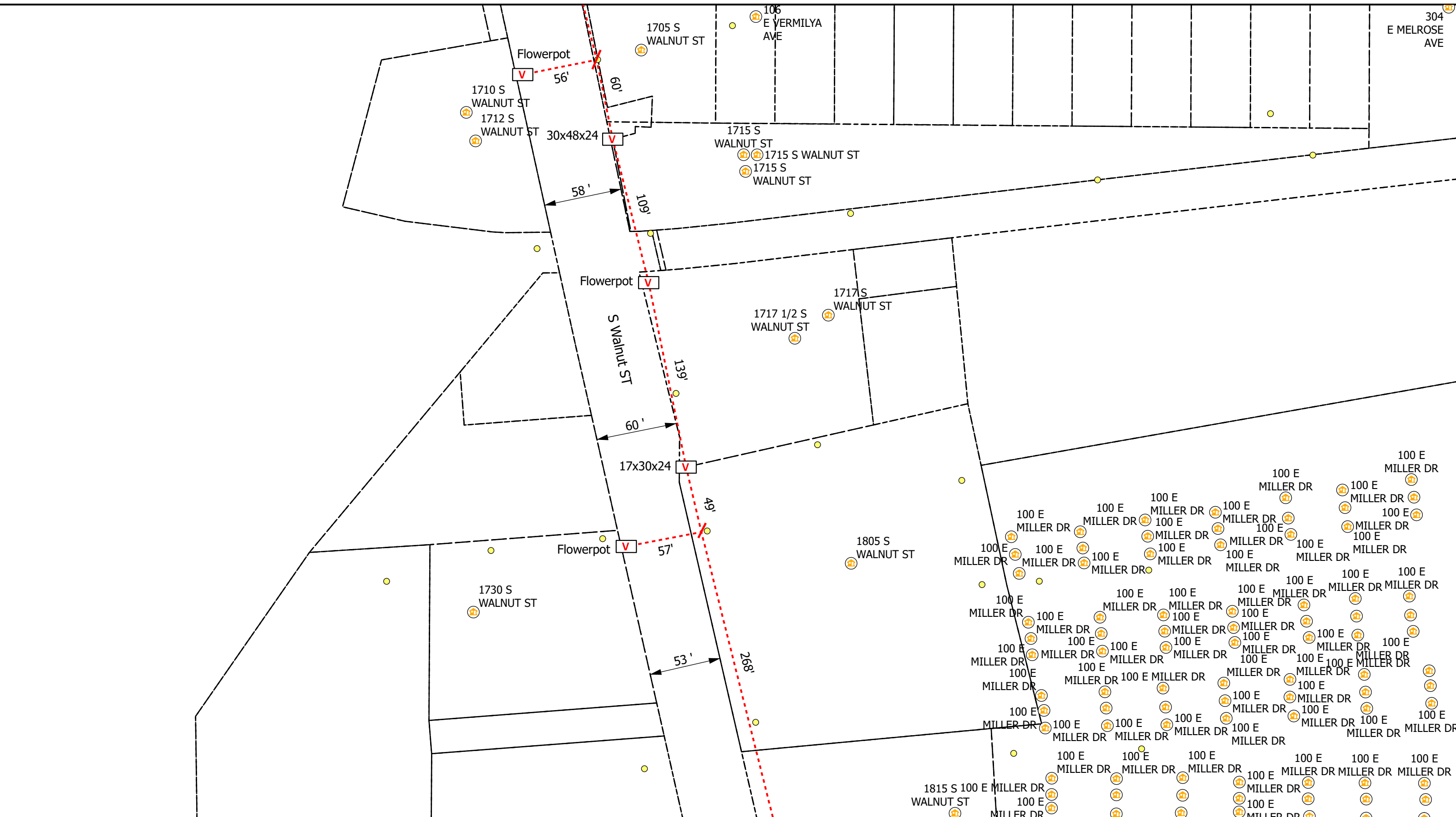

Legend

- Poles
- Ⓡ Risers
- Ⓜ Sidewalk
- V Vaults
- Overhead Strand
- Bloomington_Parcels
- Conduit
- Y Anchor
- Grids

All Flowerpots 12" DIA



City of Bloomington, IN Permit:
Design View

INI	BY	DATE	DESCRIPTION



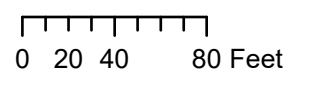
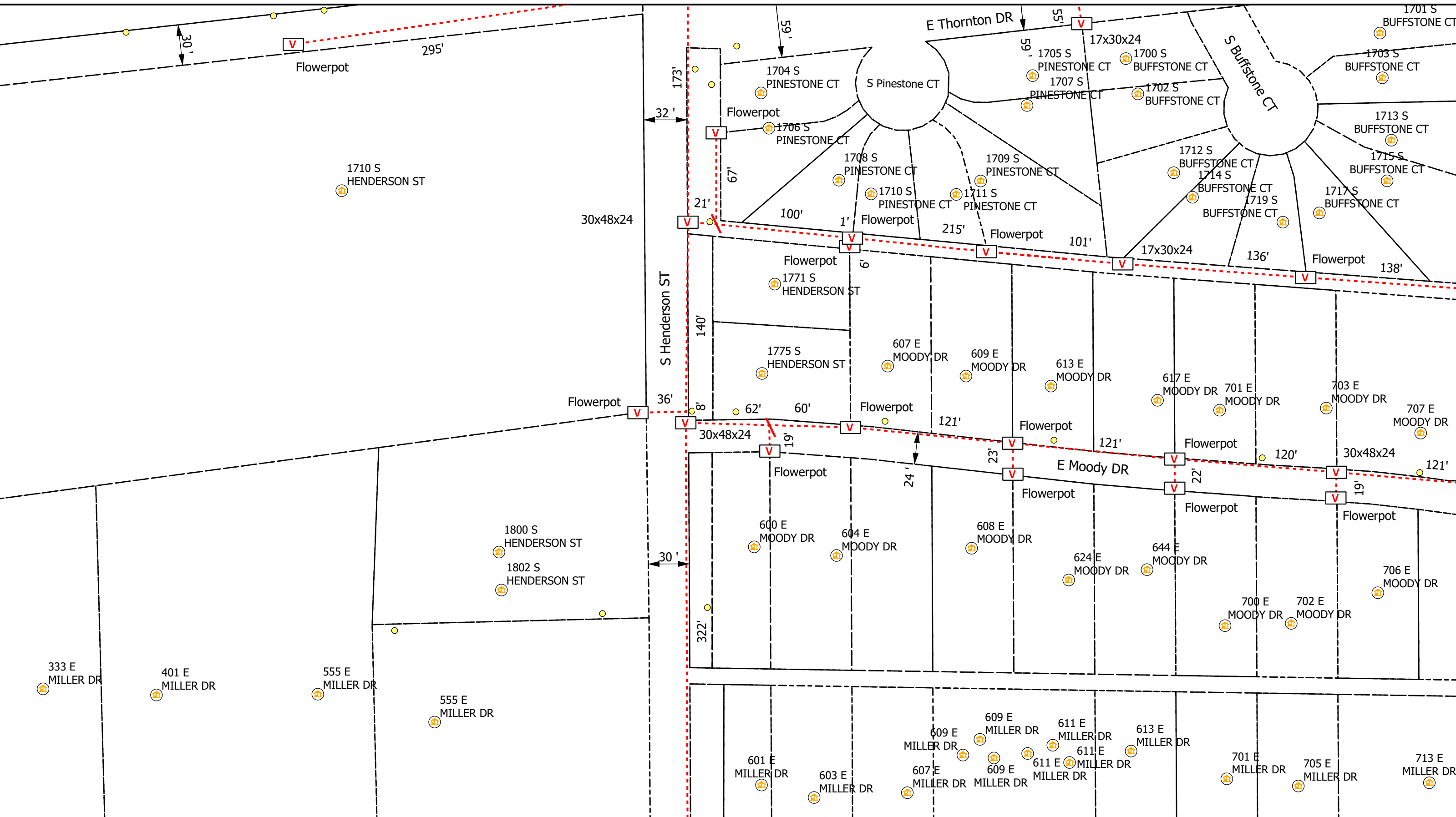

Legend

- Poles
- V Vaults
- Overhead Strand
- Conduit
- Ⓡ Risers
- Ⓜ Address
- Y Anchor
- ↖ Sidewalk
- Bloomington_Parcels
- Grids

All Flowerpots 12" DIA



City of Bloomington, IN Permit:
Design View

INI	BY	DATE	DESCRIPTION



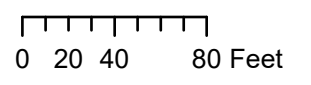
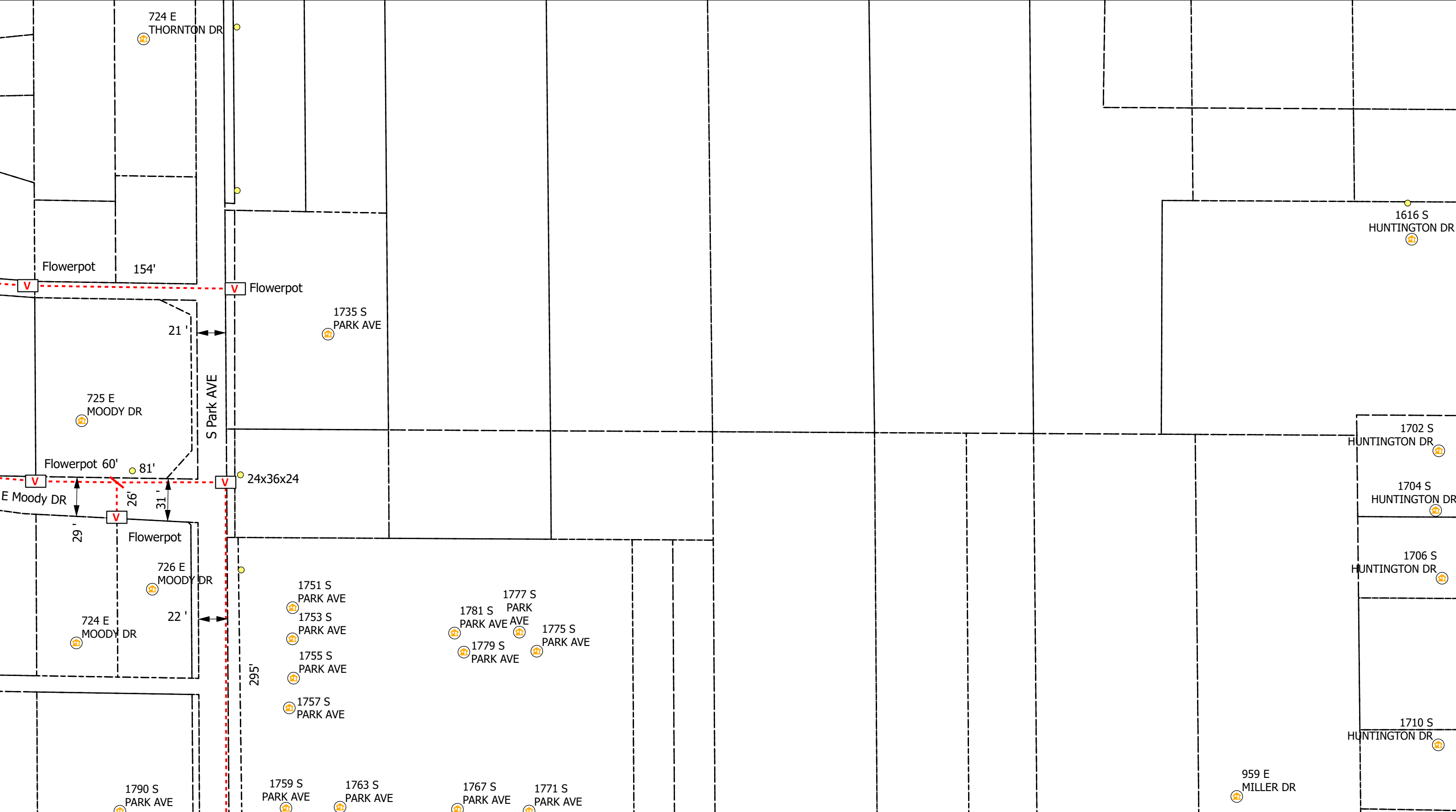

Legend

- Poles
- Risers
- Vaults
- Overhead Strand
- Conduit
- Address
- Anchor
- Sidewalk
- Bloomington_Parcels
- Grids

All Flowerpots 12" DIA



City of Bloomington, IN Permit:
Design View

INI	BY	DATE	DESCRIPTION



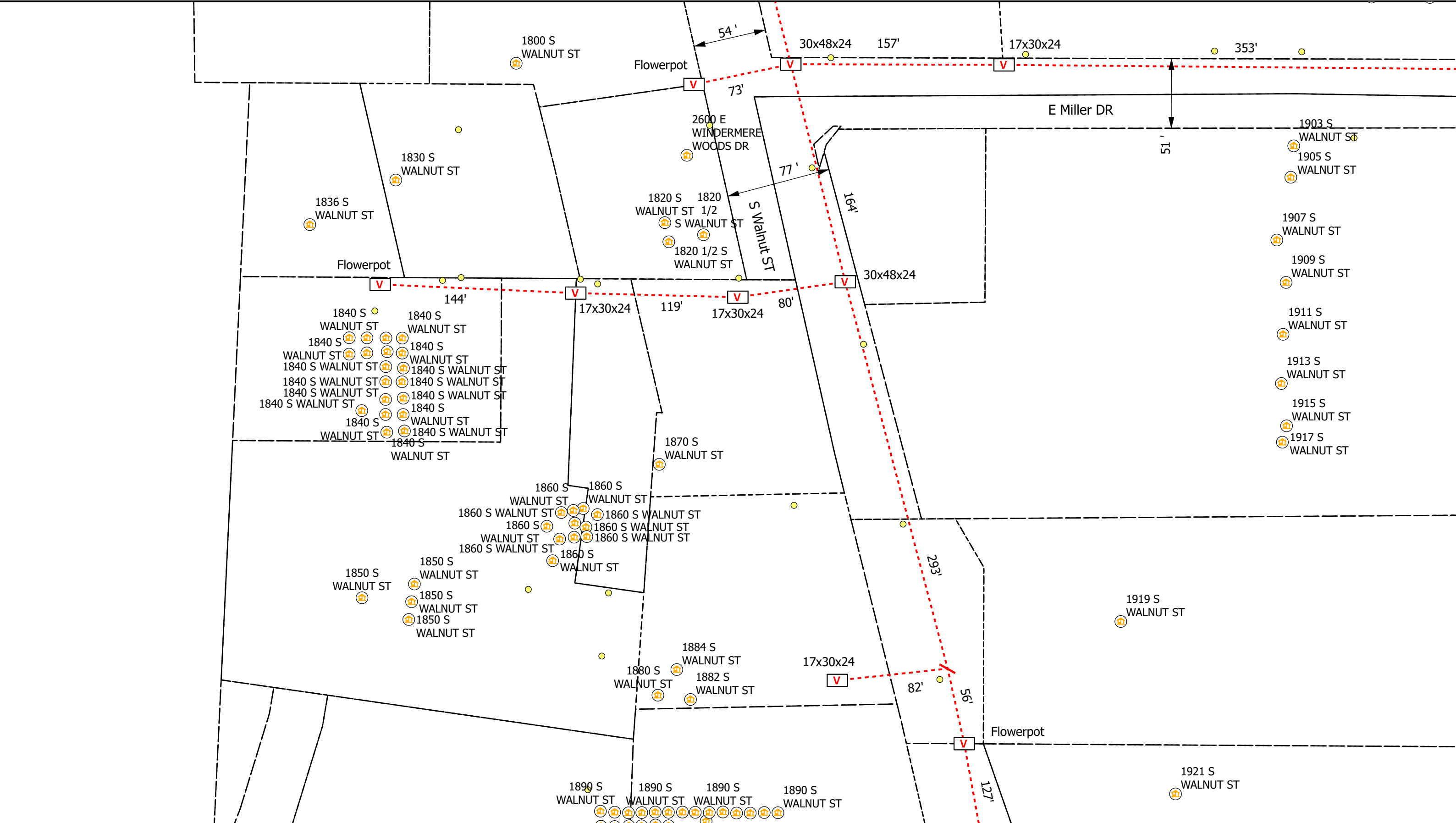

0 20 40 80 Feet

Legend

- Poles
- V Vaults
- Overhead Strand
- Conduit
- Ⓡ Risers
- Ⓜ Address
- Y Anchor
- ↖ Sidewalk
- Bloomington_Parcels
- Grids

All Flowerpots 12" DIA

N



City of Bloomington, IN Permit:
Design View

INI	BY	DATE	DESCRIPTION



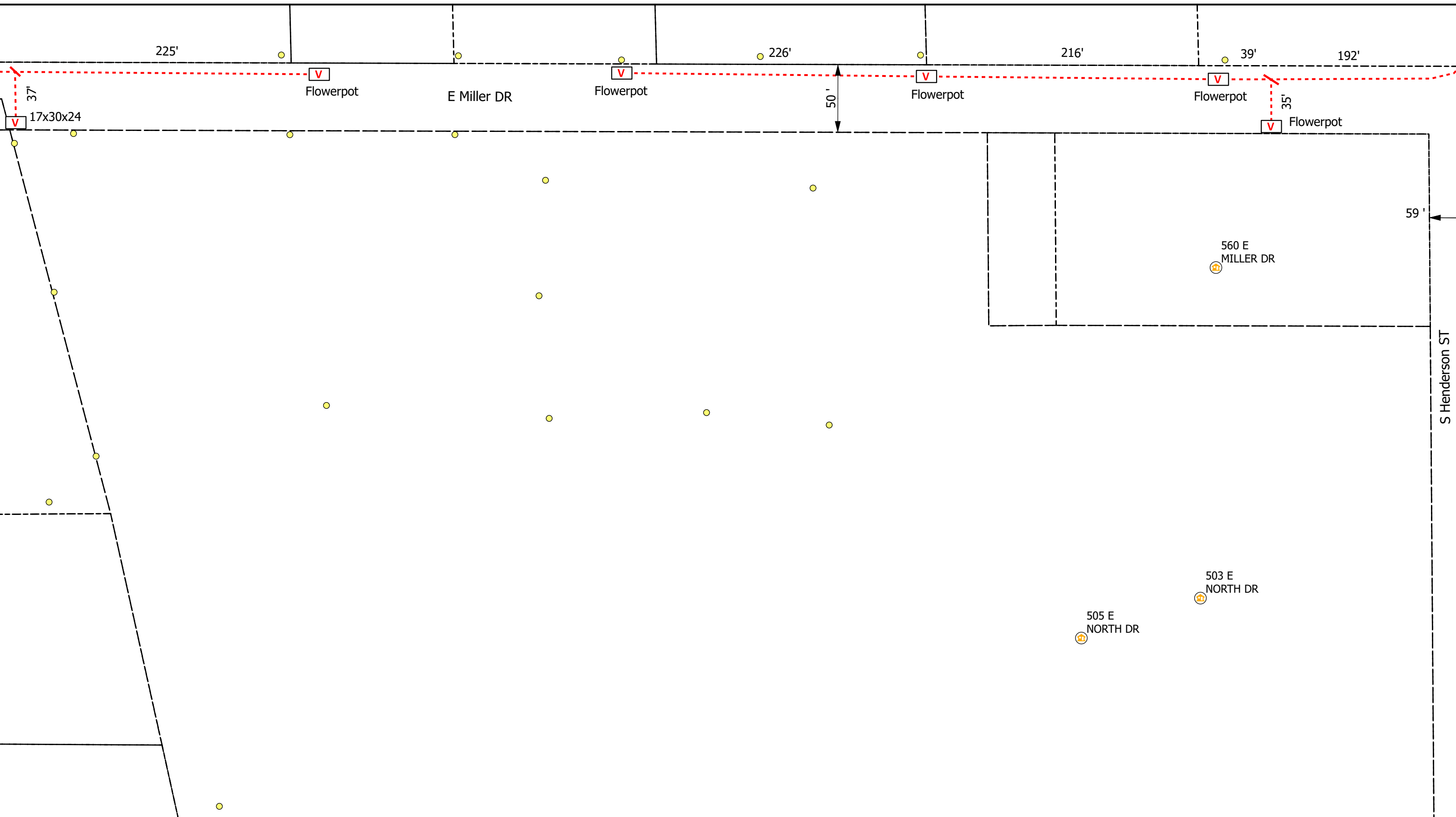

Legend

- Poles
- Vaults
- Overhead Strand
- Conduit
- Risers
- Address
- Anchor
- Sidewalk
- Bloomington_Parcels
- Grids

All Flowerpots 12" DIA

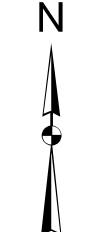

City of Bloomington, IN Permit:
Design View

INI	BY	DATE	DESCRIPTION

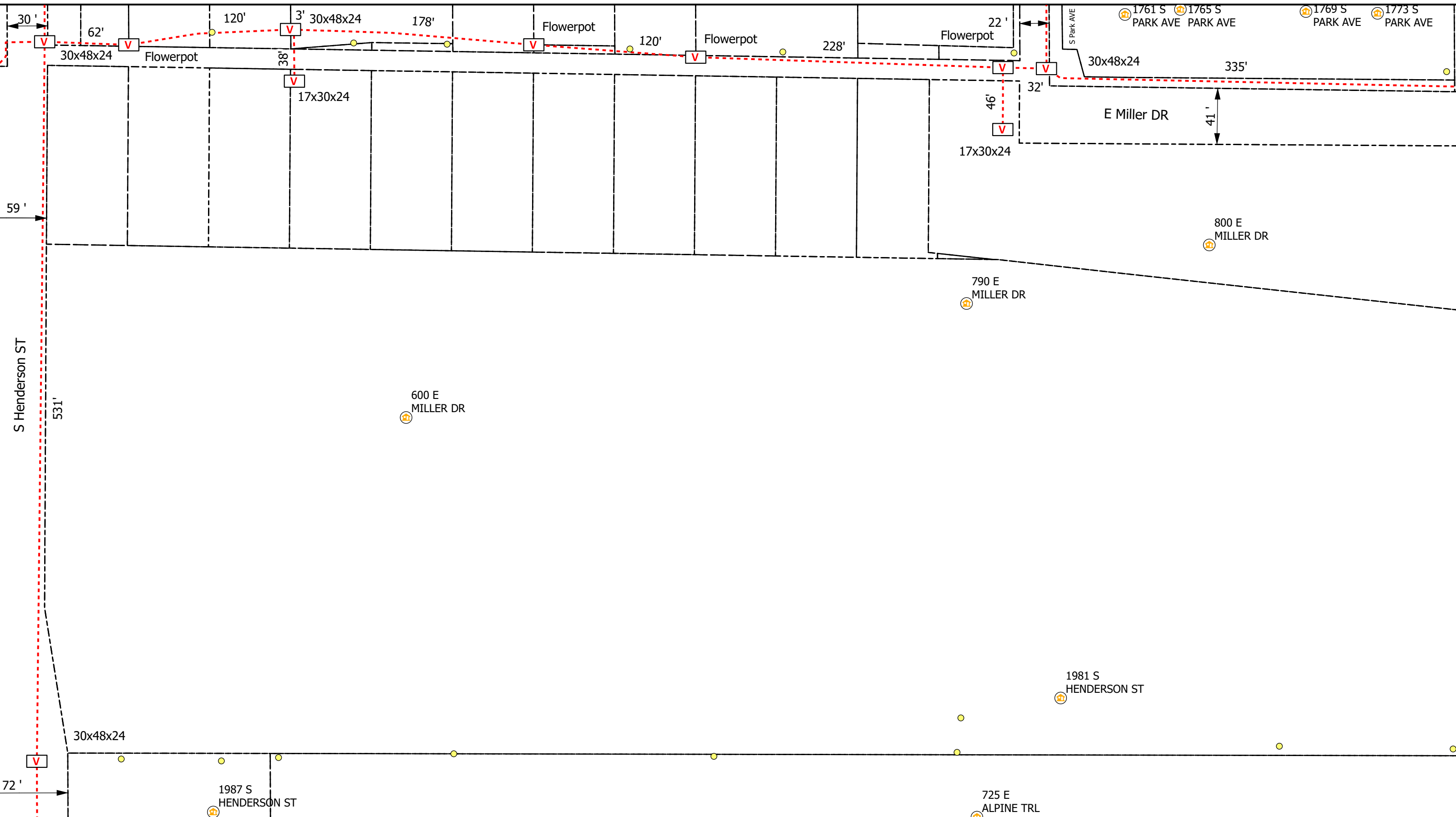

Legend

- Poles
- Risers
- Sidewalk
- Vaults
- Address
- Bloomington_Parcels
- Overhead Strand
- Anchor
- Grids
- Conduit

All Flowerpots 12" DIA

All Flowerpots 12" DIA

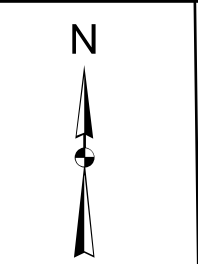

City of Bloomington, IN Permit:
Design View

INI	BY	DATE	DESCRIPTION

Print 15 of 18

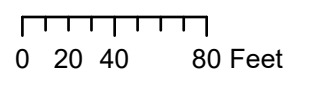
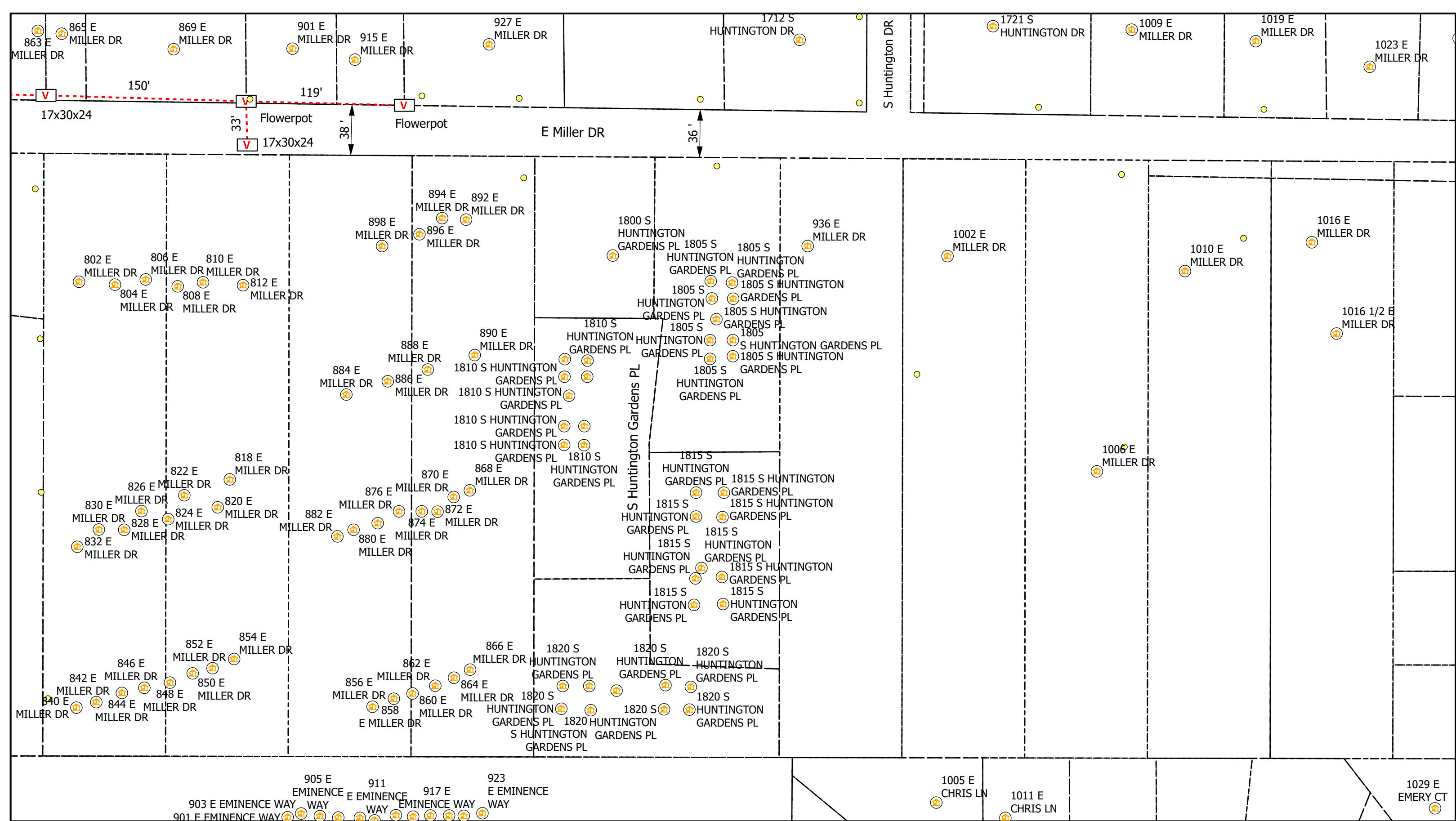

Legend

- Poles
- Ⓡ Risers
- Ⓜ Sidewalk
- V Vaults
- 🏠 Address
- Bloomington_Parcels
- Overhead Strand
- - - Conduit
- Y Anchor
- Grids

All Flowerpots 12" DIA



City of Bloomington, IN Permit:
Design View

INI	BY	DATE	DESCRIPTION



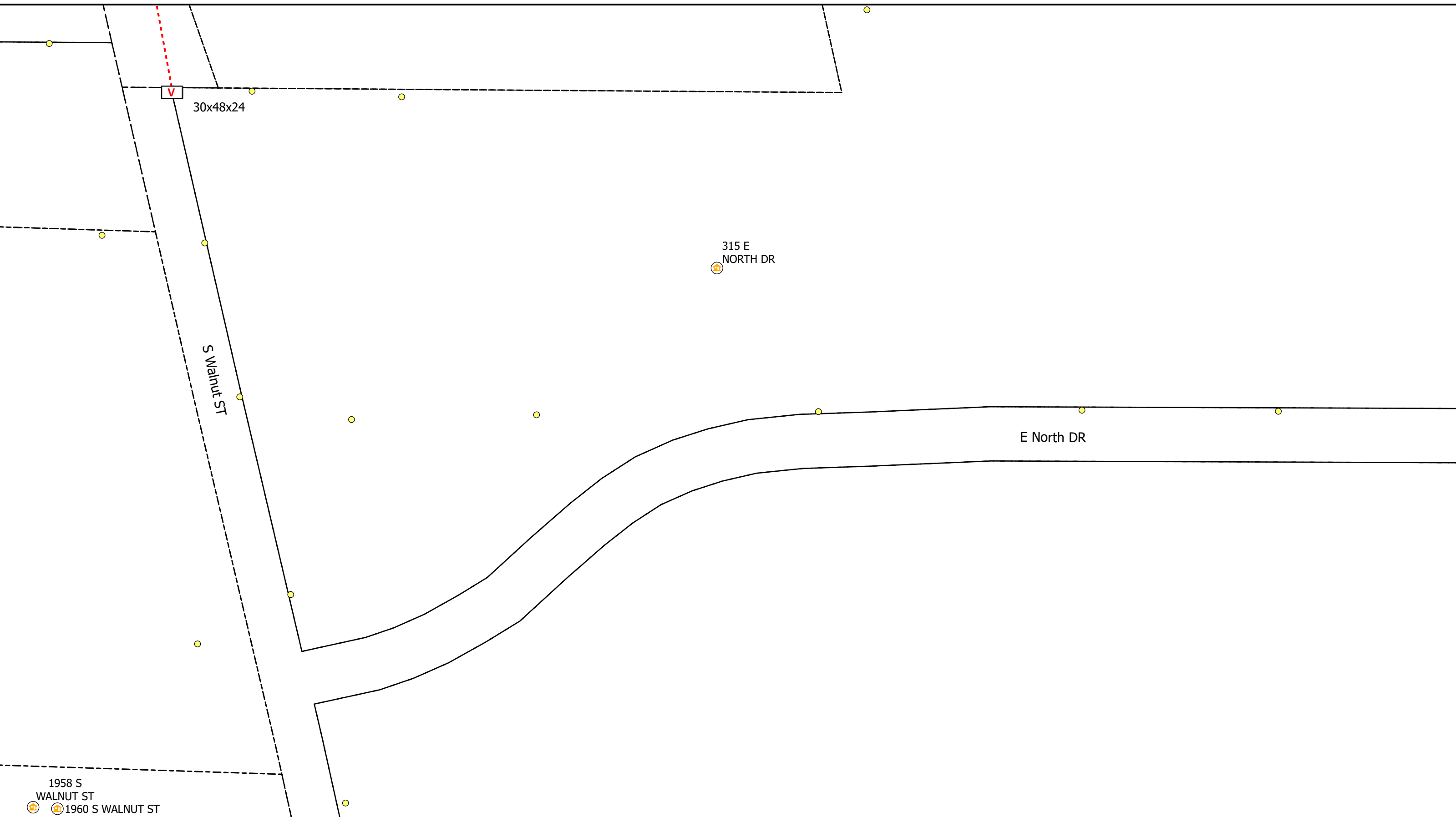

AEG

0 20 40 80 Feet

Legend

- Poles
- Vaults
- Overhead Strand
- Conduit
- Risers
- Address
- Anchor
- Sidewalk
- Bloomington_Parcels
- Grids

All Flowerpots 12" DIA

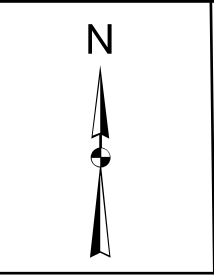

City of Bloomington, IN Permit:
Design View

INI	BY	DATE	DESCRIPTION

Indiana 811

Print 17 of 18

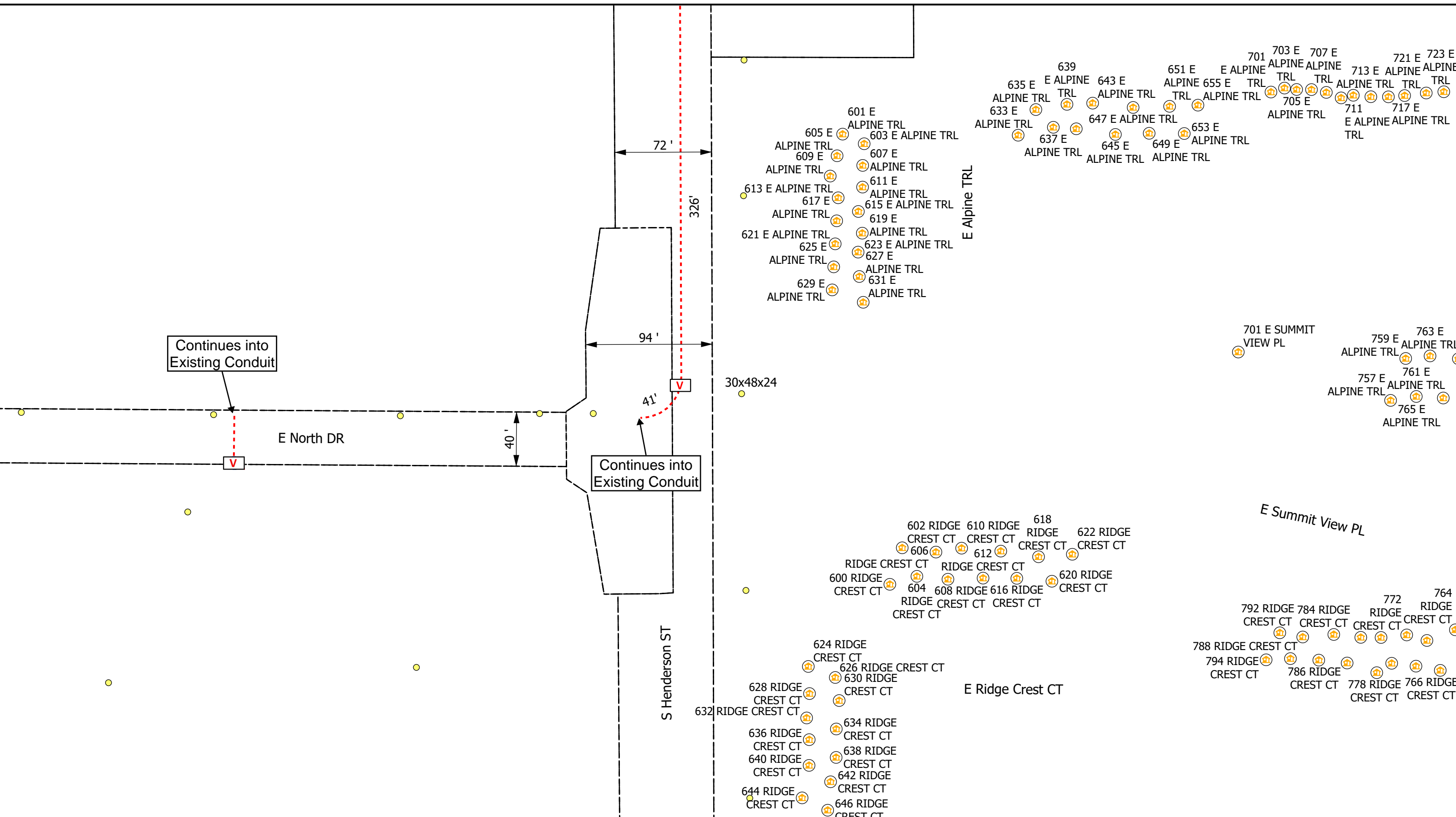

Legend

- Poles
- Risers
- Sidewalk
- Vaults
- Address
- Anchor
- Overhead Strand
- Bloomington_Parcels
- Grids
- Conduit

All Flowerpots 12" DIA

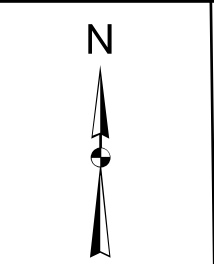

City of Bloomington, IN Permit:
Design View

INI	BY	DATE	DESCRIPTION

Print 18 of 18

Carlton® PV-Mold® Nonmetallic Pole Riser System

Carlton PV-Mold is a nonmetallic pole riser system designed to protect communications power cable installed on poles.

Features:

- Meets or exceeds requirements outlined in the National Electric Safety Code (NESC).
- Designed in accordance with NEMA TC-19 specifications.
- Ultraviolet, cold temperature and corrosive atmosphere resistant.
- Schedule 40 wall meets Schedule 80 PVC conduit impact requirements per NEMA TC-19.
- No grounding required.
- Belled end fits over each added section or conduit.
- Flame retardant.
- Requires no maintenance.
- PV-Mold acts as an insulator against electrical shock.
- Interchangeable parts and accessories to match the needs of specific requirements.



Steel U-Guard requires grounding strapping and does not have belled ends.



PV-Mold has belled ends, flanged design and does not require grounding.

Flanged Overall Length 10 Feet, Including Bell

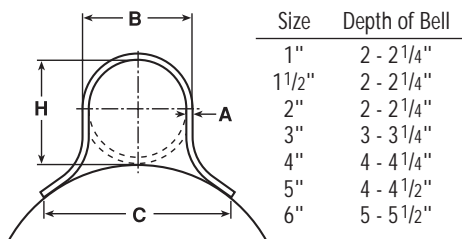

Slots are 1/2" from side to side, and allow for expansion and contraction.

Slot Dimensions: for sizes 2" through 6" are 5/16" wide, 3/4" long.

Slot Dimensions: for 1" and 1 1/2" are 3/16" wide, 3/4" long.

Slot Spacing: 18" from center, beginning 6" from end.

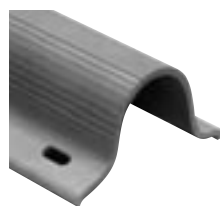

Standard Duty

Part No.	Size	Std. Ctn. Qty.	Std. Ctn. Wt. (lbs.)	Dimensions				Actual Impact @ 0°C 20 Pound Top
				A	B	C	H	
59208N	1"	294	1059	0.100"	1 5/8"	2 3/8"	1 5/8"	40 Ft.-Lbs.
59211N	2"	136	726	0.100"	2 3/8"	4 1/2"	2 3/8"	100 Ft.-Lbs.
59211X (5' length)	2"	136	363	0.100"	2 3/8"	4 1/2"	2 3/8"	100 Ft.-Lbs.
59213N	3"	66	761	0.150"	3 1/2"	6"	3 1/2"	110 Ft.-Lbs.
59213X (5' length)	3"	66	381	0.150"	3 1/2"	6"	3 1/2"	100 Ft.-Lbs.
59215N	4"	65	910	0.150"	4 1/2"	6 1/2"	4 1/2"	110 Ft.-Lbs.
59216N	5"	30	515	0.150"	5 1/2"	7 1/2"	5 1/2"	110 Ft.-Lbs.

Heavy Duty Schedule 40

59010N	1 1/2"	200	1142	0.145"	1 29/32"	3 1/2"	1 29/32"	100 Ft.-Lbs.
59011N	2"	136	1214	0.154"	2 3/8"	4 1/2"	2 3/8"	150 Ft.-Lbs.
59013N	3"	66	937	0.216"	3 1/2"	6"	3 9/32"	150 Ft.-Lbs.
59015N	4"	65	1621	0.237"	4 1/2"	6 1/2"	4 1/2"	260 Ft.-Lbs.
59015X (5' length)	4"	65	707	0.237"	4 1/2"	6 1/2"	4 1/2"	260 Ft.-Lbs.
59016N	5"	30	870	0.258"	5 1/2"	7 1/2"	5 1/2"	260 Ft.-Lbs.
59017N	6"	30	1160	0.280"	6 5/8"	8 3/4"	6 5/8"	260 Ft.-Lbs.

Extra Heavy Duty Schedule 80

59411N	2"	136	1549	0.218"	2 3/8"	4 1/2"	2 3/8"	300 Ft.-Lbs.
59413N	3"	66	1495	0.030"	3 1/2"	6"	3 1/2"	525 Ft.-Lbs.

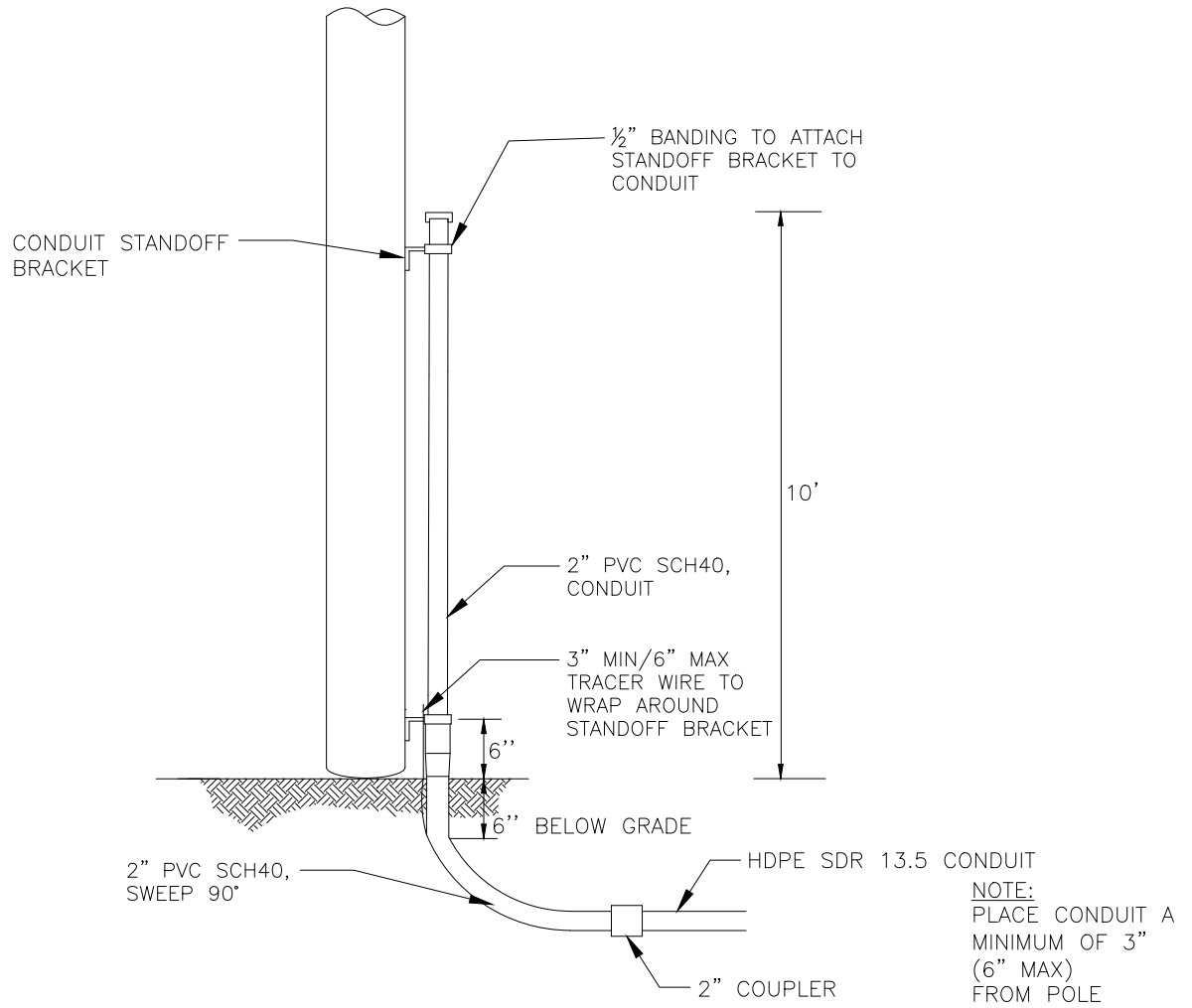

DESCRIPTION	QTY	MANUFACTURER (PREFERRED)	PART #
SCREW, LAG, 1/2" x 4-1/2"	10		
HDPE SDR 13.5 CONDUIT, VARIOUS SIZES	N/A		
2" PVC SCH40, RISER PIPE	1		
#12 TRACER WIRE	N/A		
2" PVC SCH40, SWEEP, 90 DEG	1		
CONDUIT STANDOFF BRACKET	VARIES		
CONDUIT STRAP KIT	VARIES		
2" COUPLER	1		



TYPICAL RISER
CONDUIT
WOOD POLE

(R2-W)

CONCEPTUAL SIDE VIEW

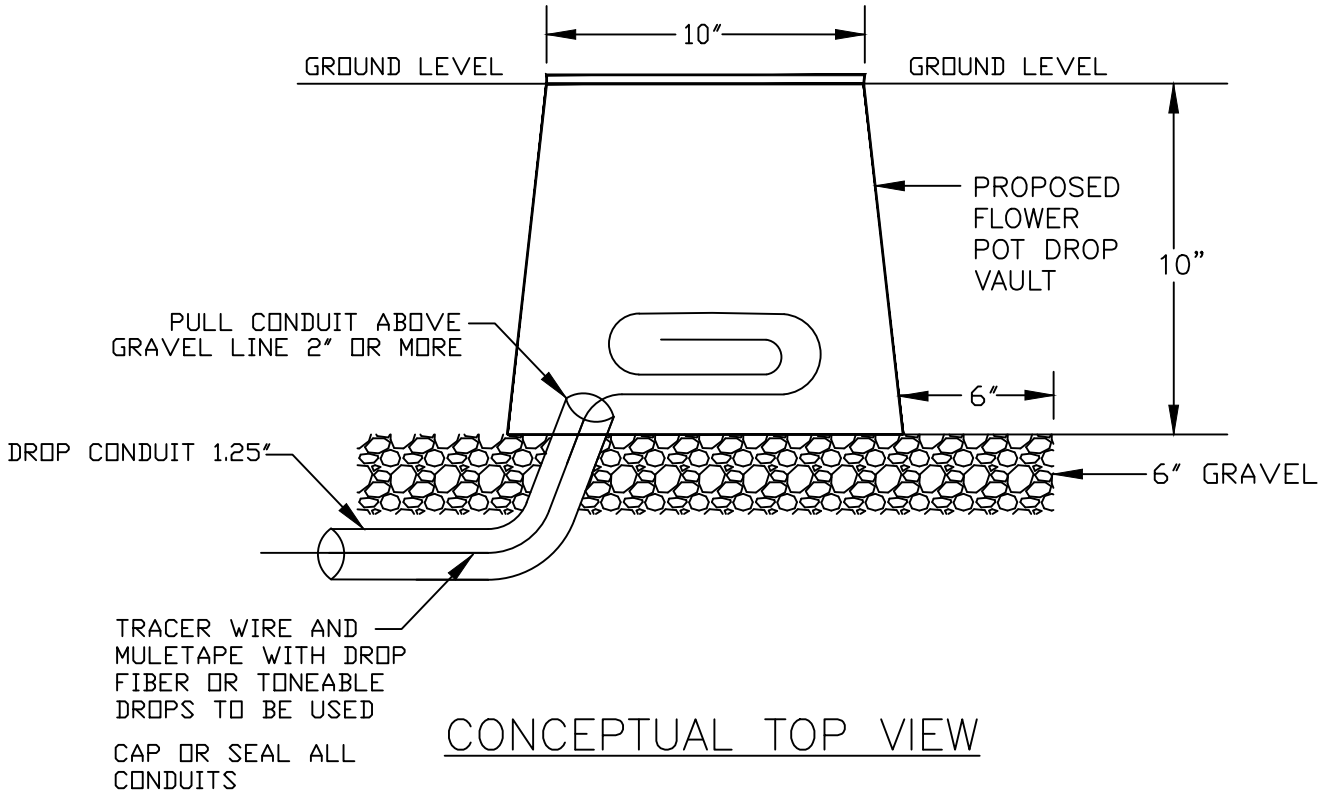

CONCEPTUAL TOP VIEW

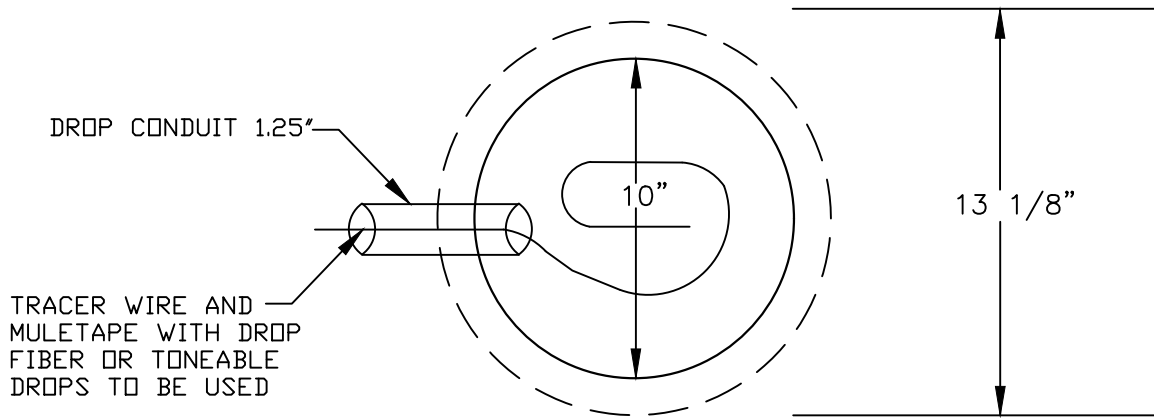

FLOWER POT

30"x48" PC UNIT, 2PC TIER 15/22
 18", 24", and 36" HEIGHT



AMERICAN POLYMER COMPANY

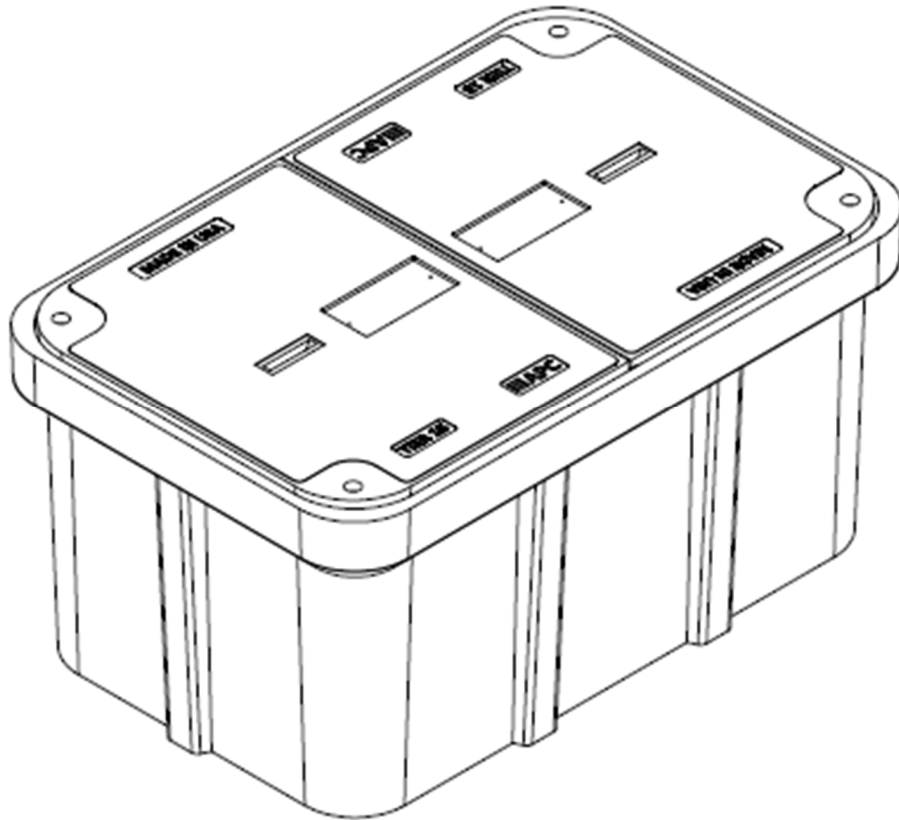

Description	Nominal Size	ANSI Tier	Part Number	Estimated Weight
PC Unit – TIER 15	30"x48"x18"	Tier 15	P304818HU15...	460 lbs.
PC Unit – TIER 22	30"x48"x18"	Tier 22	P304818HU22...	525 lbs.
PC Unit – TIER 15	30"x48"x24"	Tier 15	P304824HU15...	510 lbs.
PC Unit – TIER 22	30"x48"x24"	Tier 22	P304824HU22...	575 lbs.
PC Unit – TIER 15	30"x48"x36"	Tier 15	P304836HU15...	615 lbs.
PC Unit – TIER 22	30"x48"x36"	Tier 22	P304836HU22...	680 lbs.



30"x48" PC UNIT, 2PC TIER 15/22

18", 24", and 36" HEIGHT



AMERICAN POLYMER COMPANY

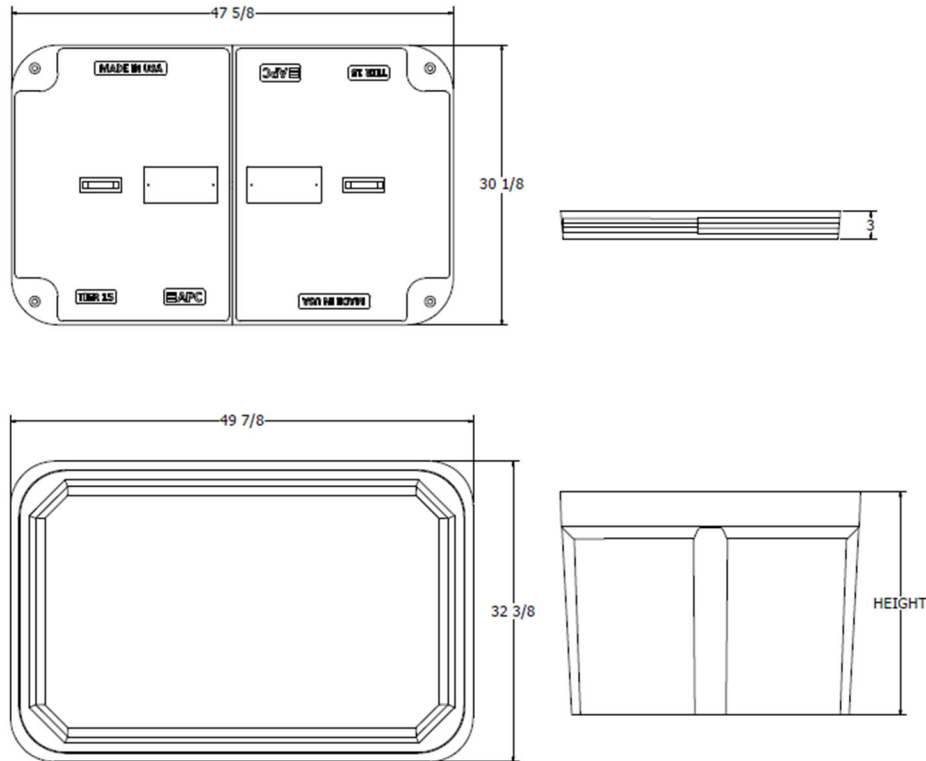

Components	Nominal Size	ANSI Tier	Part Number	Estimated Weight
Replacement Box	30"x48"x18"	Tier 22	P304818B22	185 lbs.
Replacement Box	30"x48"x24"	Tier 22	P304824B22	235 lbs.
Replacement Box	30"x48"x36"	Tier 22	P304836B22	340 lbs.
Replacement Lids - T15	30"x48" (half)	Tier 15	Various	150 lbs.
Replacement Lids - T22	30"x48" (half)	Tier 22	Various	170 lbs.

Bolt options



Machine Thread



Auger Thread



24"x36" PC UNIT, TIER 15/22
 18", 24", 30", and 36" HEIGHT



AMERICAN POLYMER COMPANY

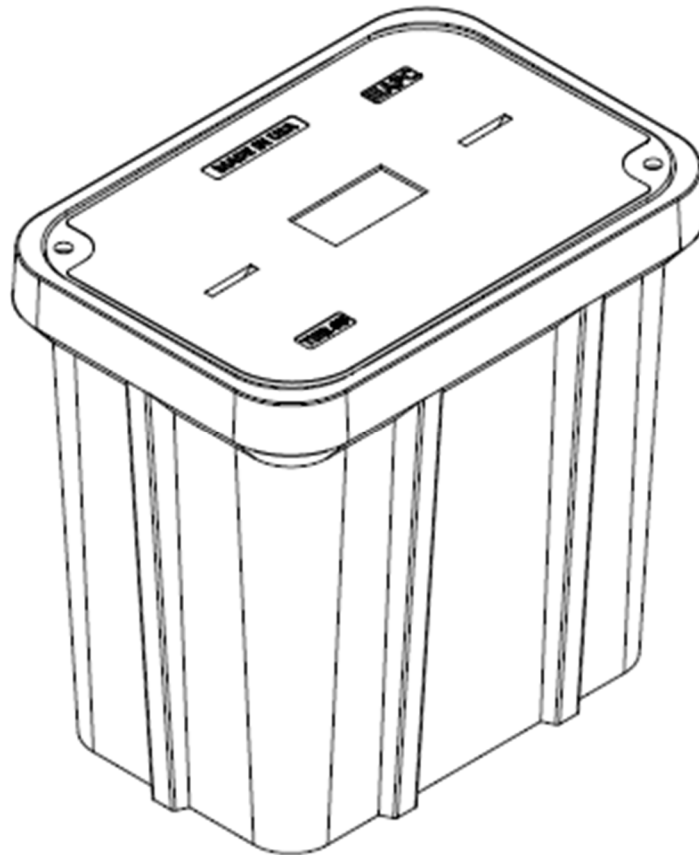

Description	Nominal Size	ANSI Tier	Part Number	Estimated Weight
PC Unit – TIER 15	24x36"x18"	Tier 15	P243618U15...	335 lbs.
PC Unit – TIER 22	24x36"x18"	Tier 22	P243618U22...	355 lbs.
PC Unit – TIER 15	24x36"x24"	Tier 15	P243624U15...	365 lbs.
PC Unit – TIER 22	24x36"x24"	Tier 22	P243624U22...	385 lbs.
PC Unit – TIER 15	24x36"x30"	Tier 15	P243630U15...	395 lbs.
PC Unit – TIER 22	24x36"x30"	Tier 22	P243630U22...	415 lbs.
PC Unit – TIER 15	24x36"x36"	Tier 15	P243636U15...	425 lbs.
PC Unit – TIER 22	24x36"x36"	Tier 22	P243636U22...	445 lbs.



24"x36" PC UNIT, TIER 15/22

18", 24", 30", and 36" HEIGHT



AMERICAN POLYMER COMPANY

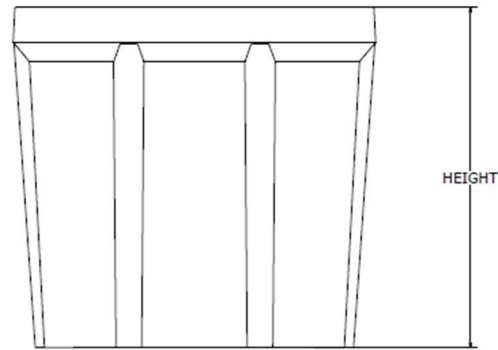
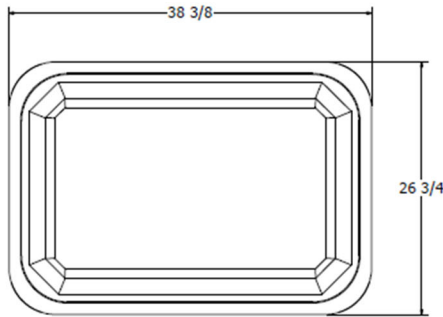
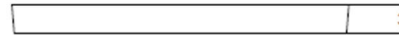
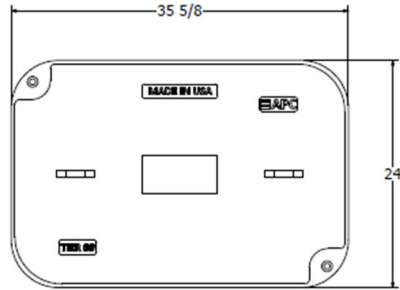

Components	Nominal Size	ANSI Tier	Part Number	Estimated Weight
Replacement Box	24"x36"x18"	Tier 22	P243618B22	165 lbs.
Replacement Box	24"x36"x24"	Tier 22	P243624B22	195 lbs.
Replacement Box	24"x36"x30"	Tier 22	P243630B22	225 lbs.
Replacement Box	24"x36"x36"	Tier 22	P243636B22	255 lbs.
Replacement Lids - T15	24"x36"	Tier 15	Various	170 lbs.
Replacement Lids - T22	24"x36"	Tier 22	Various	190 lbs.

Bolt options

Hex Head



Machine Thread



Penta Head



Auger Thread



17"x30" PC UNIT, TIER 15/22

12", 18", 24", and 30" HEIGHT



AMERICAN POLYMER COMPANY

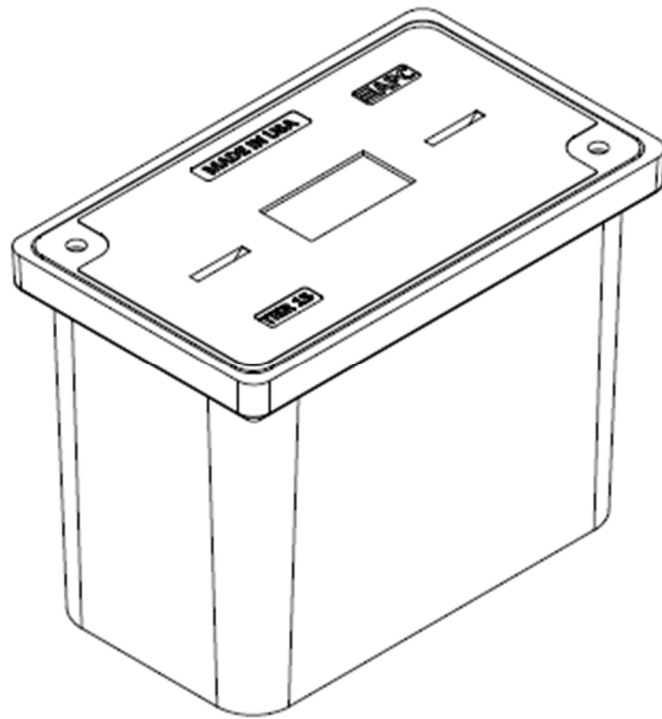

Description	Nominal Size	ANSI Tier	Part Number	Estimated Weight
PC Unit – TIER 15	17"x30"x12"	Tier 15	P173012U15...	138 lbs.
PC Unit – TIER 22	17"x30"x12"	Tier 22	P173012U22...	147 lbs.
PC Unit – TIER 15	17"x30"x18"	Tier 15	P173018U15...	172 lbs.
PC Unit – TIER 22	17"x30"x18"	Tier 22	P173018U22...	181 lbs.
PC Unit – TIER 15	17"x30"x24"	Tier 15	P173024U15...	192 lbs.
PC Unit – TIER 22	17"x30"x24"	Tier 22	P173024U22...	201 lbs.
PC Unit – TIER 15	17"x30"x30"	Tier 15	P173030U15...	217 lbs.
PC Unit – TIER 22	17"x30"x30"	Tier 22	P173030U22...	226 lbs.



17"x30" PC UNIT, TIER 15/22

12", 18", 24", and 30" HEIGHT



AMERICAN POLYMER COMPANY

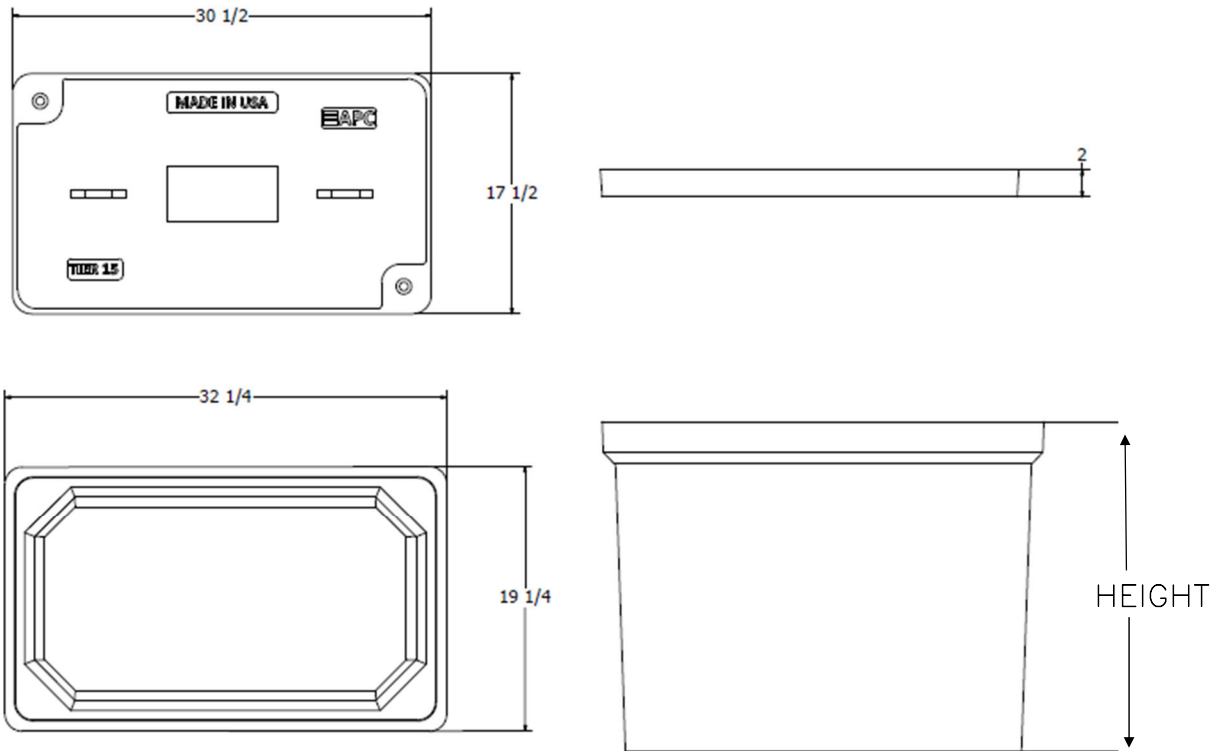

Components	Nominal Size	ANSI Tier	Part Number	Estimated Weight
Replacement Box	17"x30"x12"	Tier 22	P173012B22	66 lbs.
Replacement Box	17"x30"x18"	Tier 22	P173018B22	100 lbs.
Replacement Box	17"x30"x24"	Tier 22	P173024B22	120 lbs.
Replacement Box	17"x30"x30"	Tier 22	P173030B22	145 lbs.
Replacement Lids – T15	17"x30"	Tier 15	Various	72 lbs.
Replacement Lids – T22	17"x30"	Tier 22	Various	81 lbs.

Bolt options



Machine Thread



Auger Thread



33"x60" PC UNIT, 2PC TIER 15/22
36" HEIGHT



AMERICAN POLYMER COMPANY

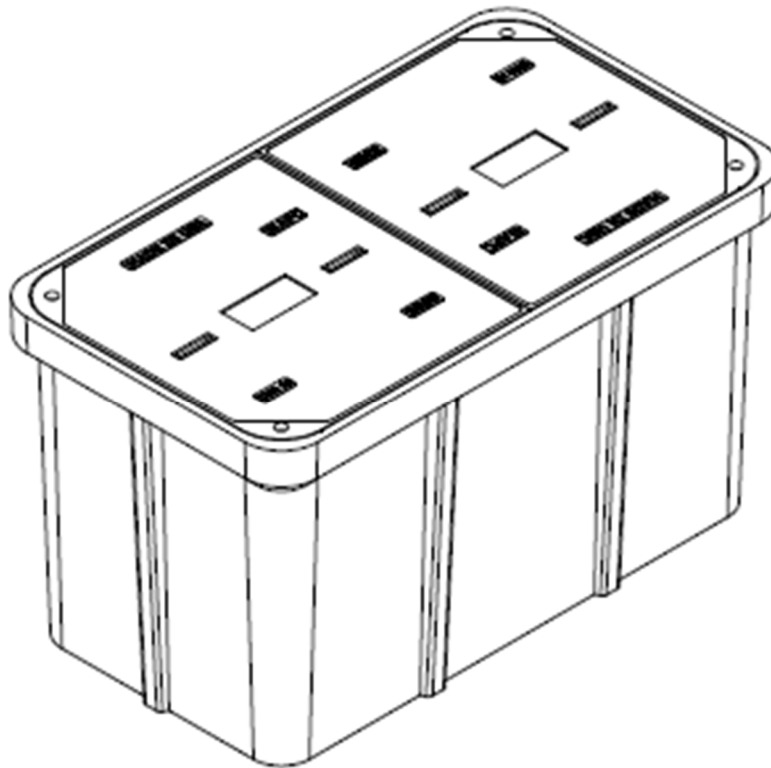

Description	Nominal Size	ANSI Tier	Part Number	Estimated Weight
PC Unit - TIER 15	33"x60"x36"	Tier 15	P336036U15...	930 lbs.
PC Unit - TIER 22	33"x60"x36"	Tier 22	P336036U22...	1030 lbs.



33"x60" PC UNIT, 2PC TIER 15/22

36" HEIGHT



AMERICAN POLYMER COMPANY

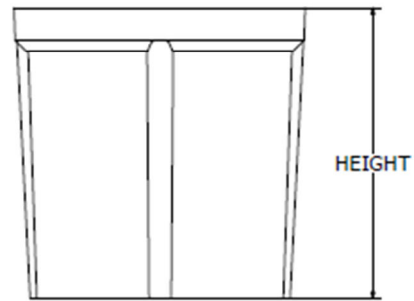
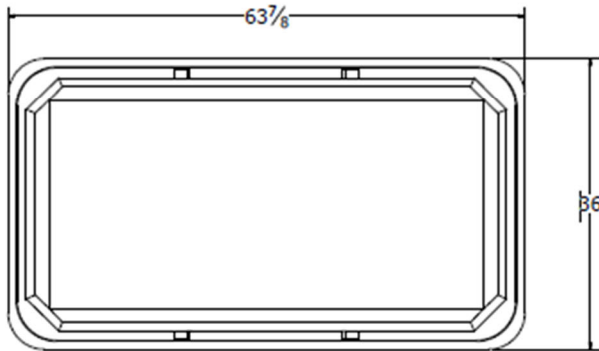
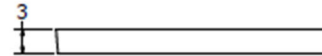
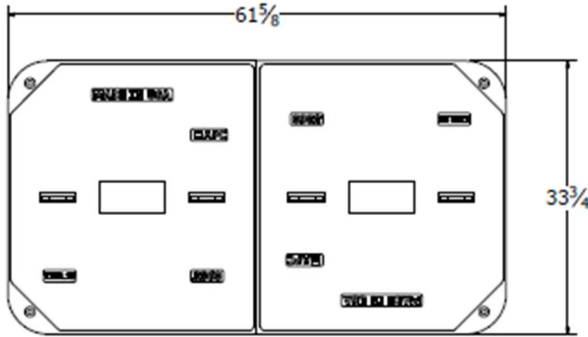

Components	Nominal Size	ANSI Tier	Part Number	Estimated Weight
Replacement Box	33"x60"x36"	Tier 22	P336036B22	530 lbs.
Replacement Lids - T15	33"x60" (half)	Tier 15	Various	200 lbs.
Replacement Lids - T22	33"x60" (half)	Tier 22	Various	250 lbs.

Bolt options

Hex Head



Machine Thread



Penta Head



Auger Thread



Speed (MPH) Prior To Road Work	SIGN SPACING, FT.		MUTCD Must be Approved by an Engineer				
	Non-Divided Highways	Divided Highways	BUFFER SPACE, FT.	TAPER LENGTH, FT.	Lane (12' R. Width)	Through Taper	Through Buffer/Work Area
	Length	Length	Shoulder (10 ft. Width)	Through Taper	Through Buffer/Work Area	Through Buffer/Work Area	
0-35	200	200	250	70	245	35	50
40-45	350	500	360	150	540	40	80
50-55	500	1000	495	185	660	50	100
60-70	SA-1000, SB-1500, SC-2640		730	235	840	60	120
Urban Low Speed - 100 FT							

APPROVED/ACCEPTED BY:
ENGINEER, OWNER, or PRIME CONTRACTOR
 Check for Notice to Proceed.

Signature: _____

Company: _____

Road Runner Safety Services, Inc.

Date: 4/25/2024 Project: BLC02a-F07 E Moody Dr ;
Traffic Control Suggestion For: ATLANTIC ENGINEERING (AEG) ;
By: Road Runner Safety Services, Inc. : Nathan

Comments:
Drawing not to scale. Traffic control plan must be approved by an engineer. This is a suggestion only. Road Runners Safety Services, Inc. has no liability for this suggested traffic control plan. Actual placement and spacing of all traffic control devices will depend on field conditions and must conform to MUTCD standards.

- Manifest**
- 6 x ADA Barricade
 - 1 x Arrow Board
 - 46 x Channelizer
 - 5 x End Construction
 - 2 x Flagger
 - 1 x Lane Ends (R)
 - 3 x No Parking
 - 2 x One Lane Road Ahead
 - 1 x Right Lane Closed Ahead
 - 10 x Road Construction Ahead
 - 5 x Sidewalk Closed
 - 5 x Sidewalk Closed Ahead Cross Here (R,L)
 - 1 x Sidewalk Closed Use Other Side

- Legend**
- ADA Barricade
 - Arrow Board
 - Channelizer
 - Conduit
 - Flagger (Person)
 - Sign
 - Vault
 - Work Area



Work area will move along indicated lines.
Flagger setup to be used on residential 2 lane streets.
No parking setup to be used on one way streets.
Lane Closure shown below to be used on Walnut St.

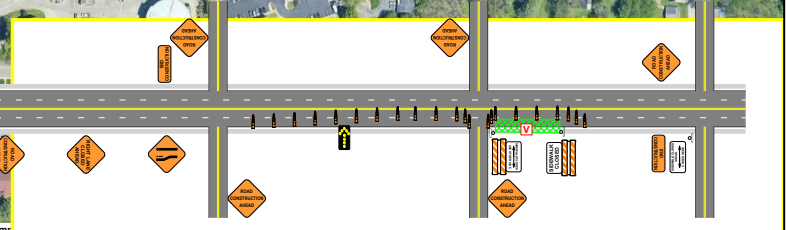
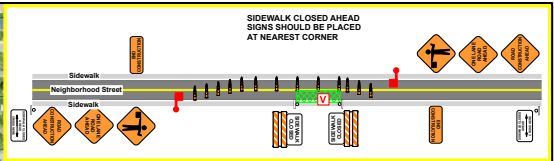

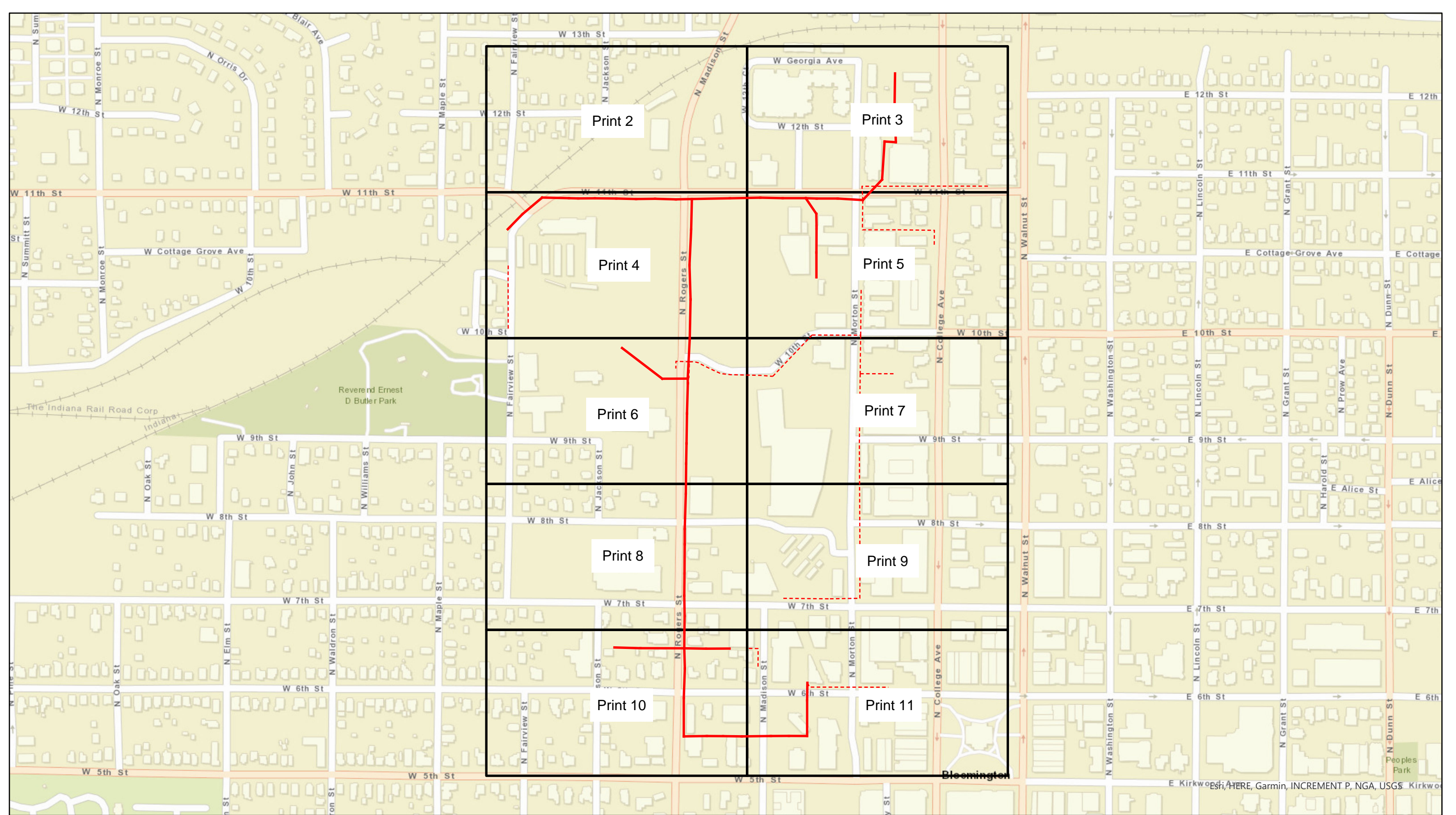

Legend BLN01b-F10_N Morton St

- Overhead Strand
- - - Conduit
- Grids



City of Bloomington, IN Permit:
Design View

INI	BY	DATE	DESCRIPTION

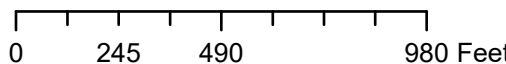

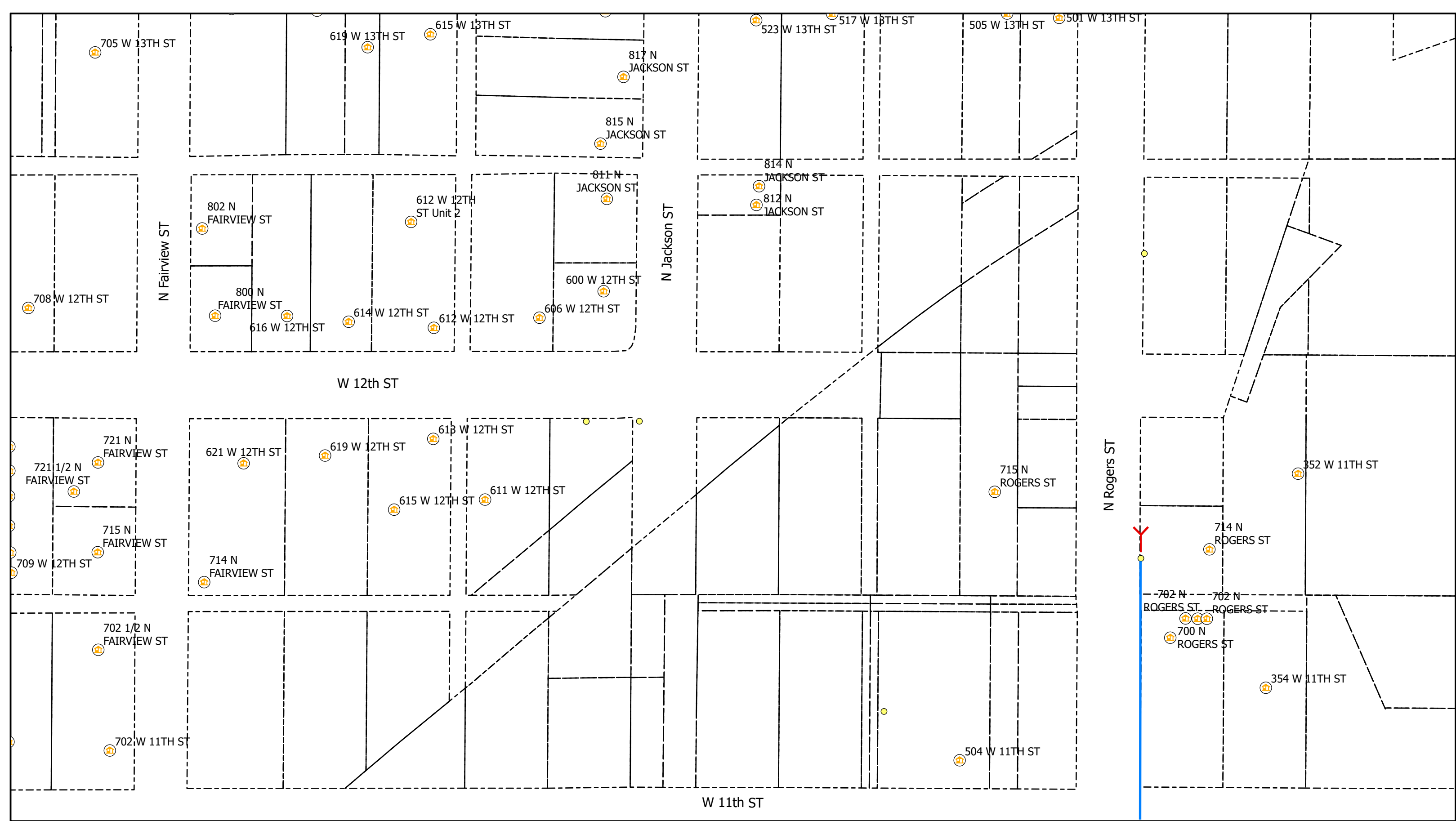

0 20 40 80 Feet

Legend

- Poles
- V Vaults
- Overhead Strand
- - - Conduit
- Ⓡ Risers
- 🏠 Address
- Y Anchor
- ↖ Sidewalk
- Bloomington_Parcels
- Grids

All Flowerpots 12" DIA



City of Bloomington, IN Permit:
Design View

INI	BY	DATE	DESCRIPTION



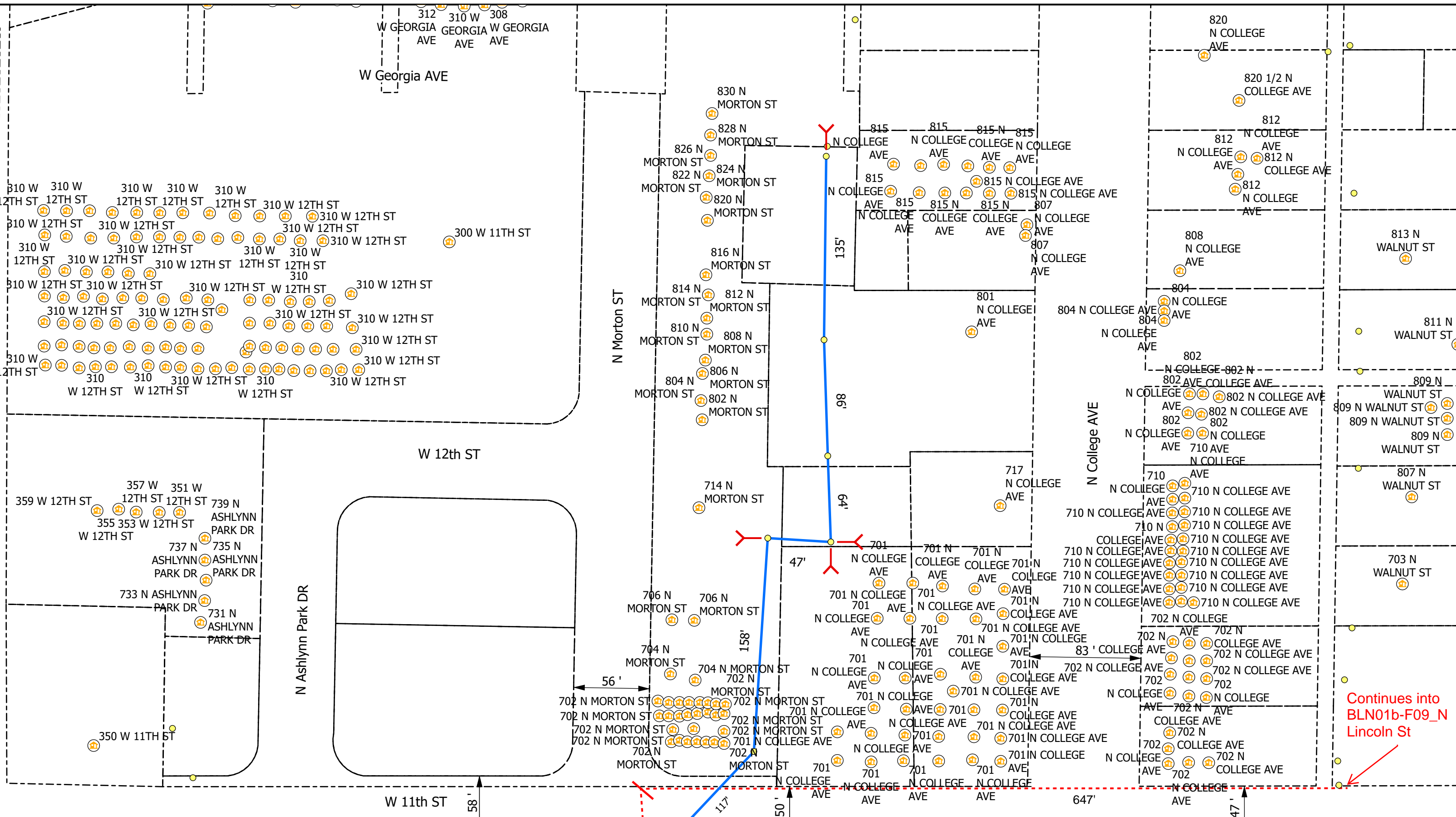

Legend

- Poles
- V Vaults
- Overhead Strand
- Conduit
- Ⓡ Risers
- Ⓜ Address
- Y Anchor
- ↖ Sidewalk
- Bloomington_Parcels
- Grids

All Flowerpots 12" DIA

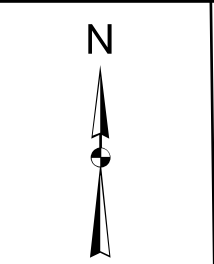

City of Bloomington, IN Permit:
Design View

INI	BY	DATE	DESCRIPTION

Print 3 of 11

Continues into
BLN01b-F09_N
Lincoln St

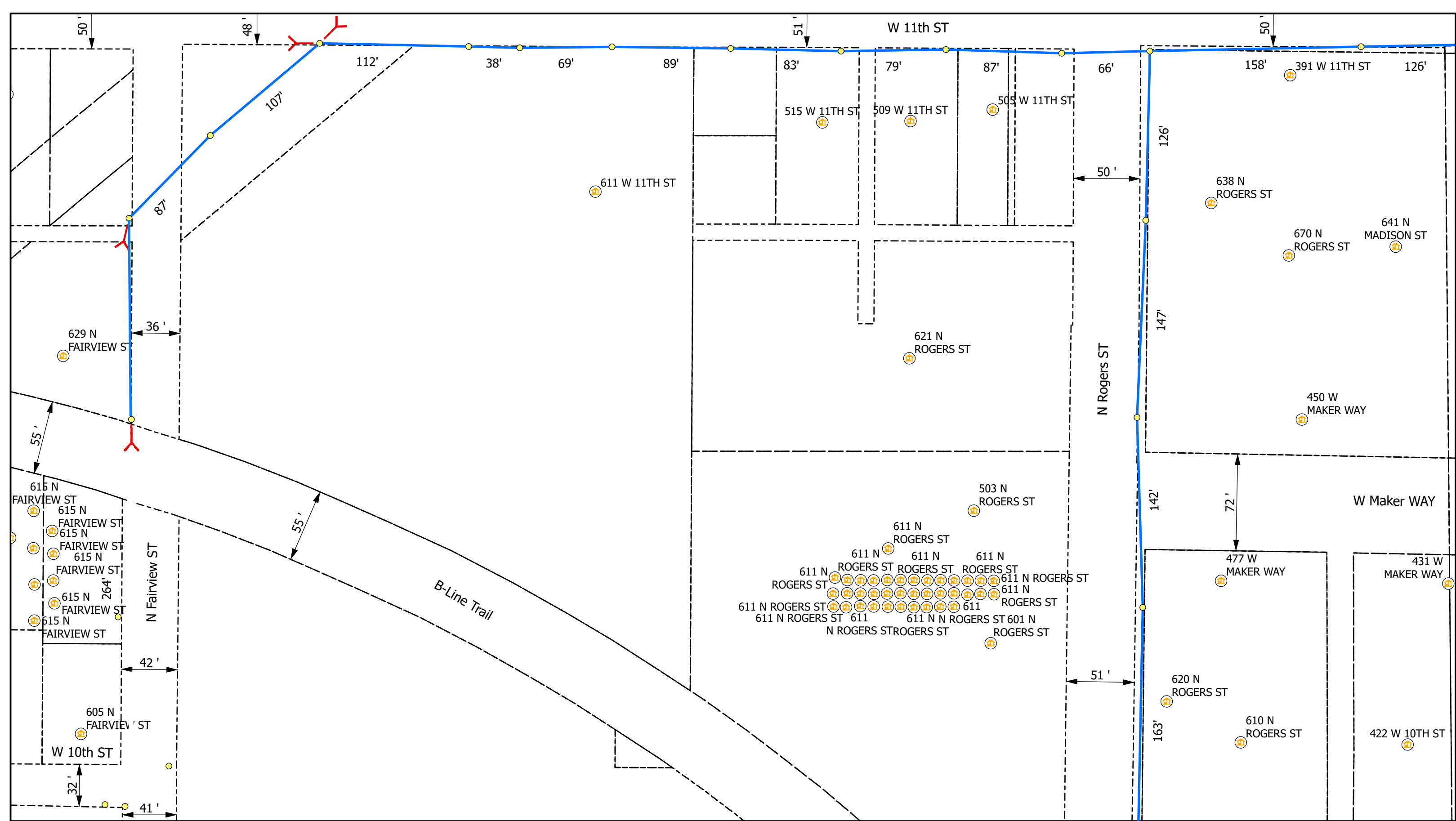

Legend

- Poles
- Ⓡ Risers
- ⌞ Sidewalk
- V Vaults
- 🏠 Address
- Bloomington_Parcels
- Overhead Strand
- Y Anchor
- Grids
- Conduit

All Flowerpots 12" DIA



City of Bloomington, IN Permit:
Design View

INI	BY	DATE	DESCRIPTION



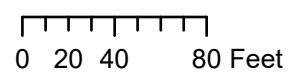
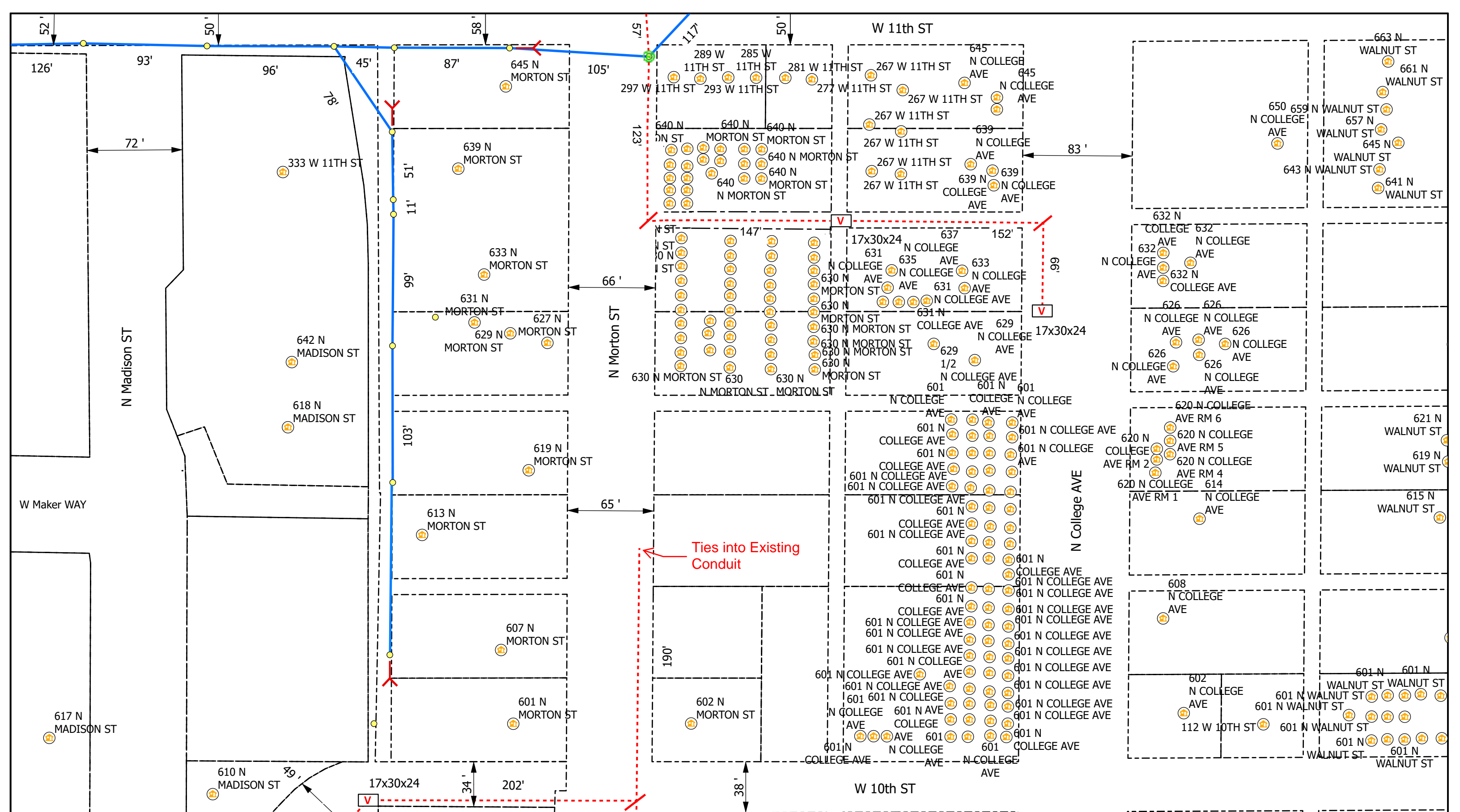

Legend

- Poles
- V Vaults
- Overhead Strand
- - - Conduit
- R Risers
- 🏠 Address
- Y Anchor
- ↖ Sidewalk
- Bloomington_Parcels
- Grids

All Flowerpots 12" DIA



City of Bloomington, IN Permit:
Design View

INI	BY	DATE	DESCRIPTION



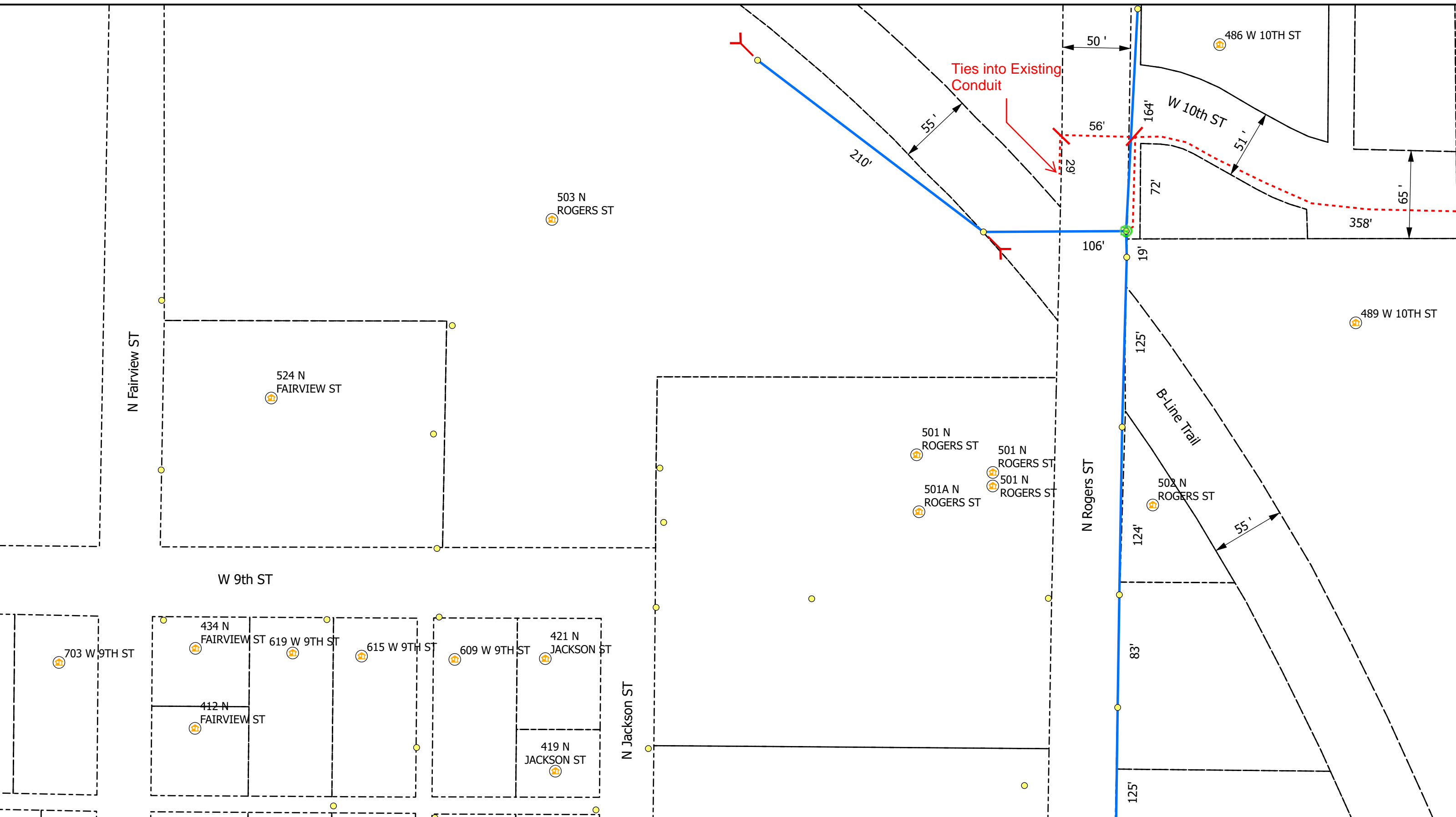

Ties into Existing Conduit



Legend

- Poles
- Ⓡ Risers
- Ⓜ Address
- Ⓜ Anchor
- V Vaults
- Overhead Strand
- Conduit
- ↖ Sidewalk
- Bloomington_Parcels
- Grids

All Flowerpots 12" DIA



City of Bloomington, IN Permit:
Design View

INI	BY	DATE	DESCRIPTION



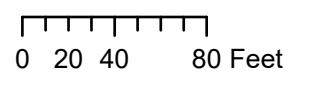
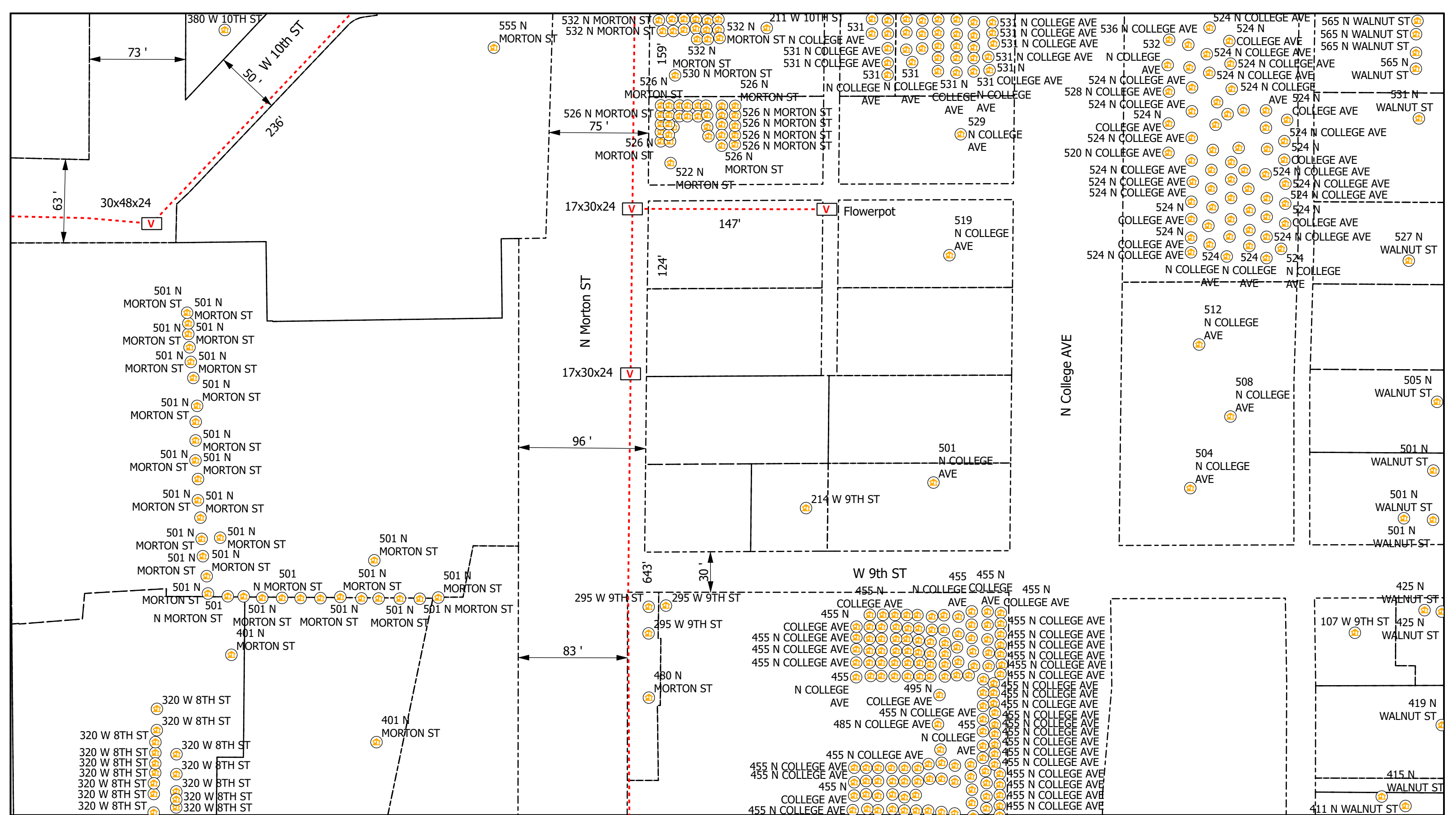

Legend

- Poles
- Ⓡ Risers
- V Vaults
- Overhead Strand
- - - Conduit
- 🏠 Address
- Y Anchor
- ↖ Sidewalk
- Bloomington_Parcels
- Grids

All Flowerpots 12" DIA



City of Bloomington, IN Permit:
Design View

INI	BY	DATE	DESCRIPTION



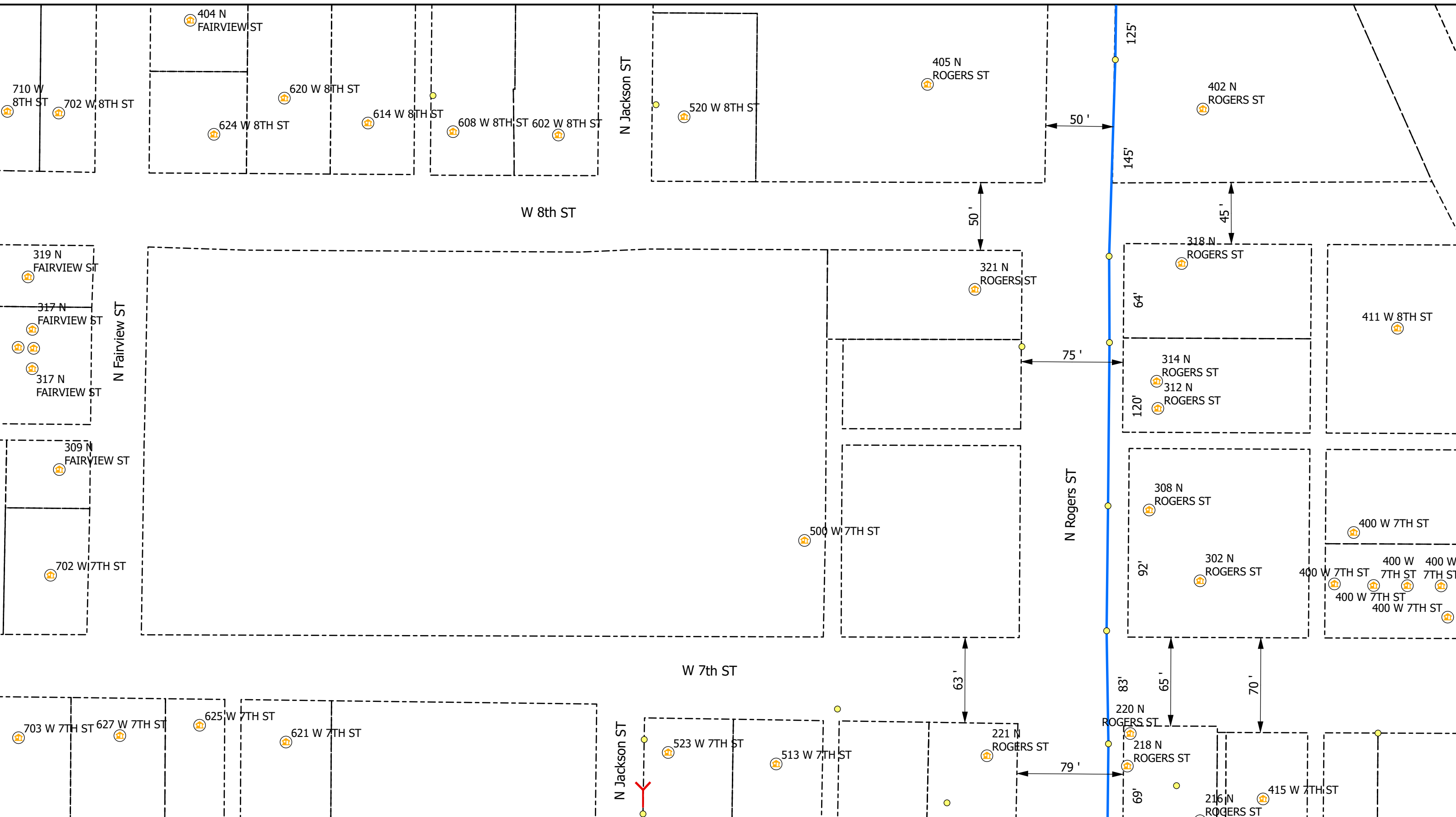

AEG

0 20 40 80 Feet

Legend

- Poles
- Ⓟ Risers
- Ⓜ Address
- Y Anchor
- V Vaults
- Overhead Strand
- Conduit
- └ Sidewalk
- Bloomington_Parcels
- Grids

All Flowerpots 12" DIA

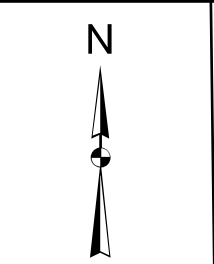

City of Bloomington, IN Permit:
Design View

INI	BY	DATE	DESCRIPTION

Indiana 811

Print 8 of 11

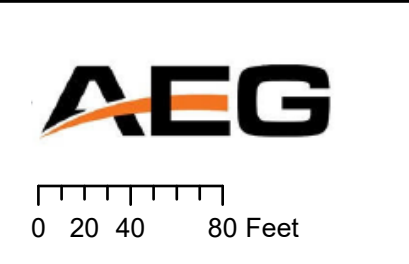
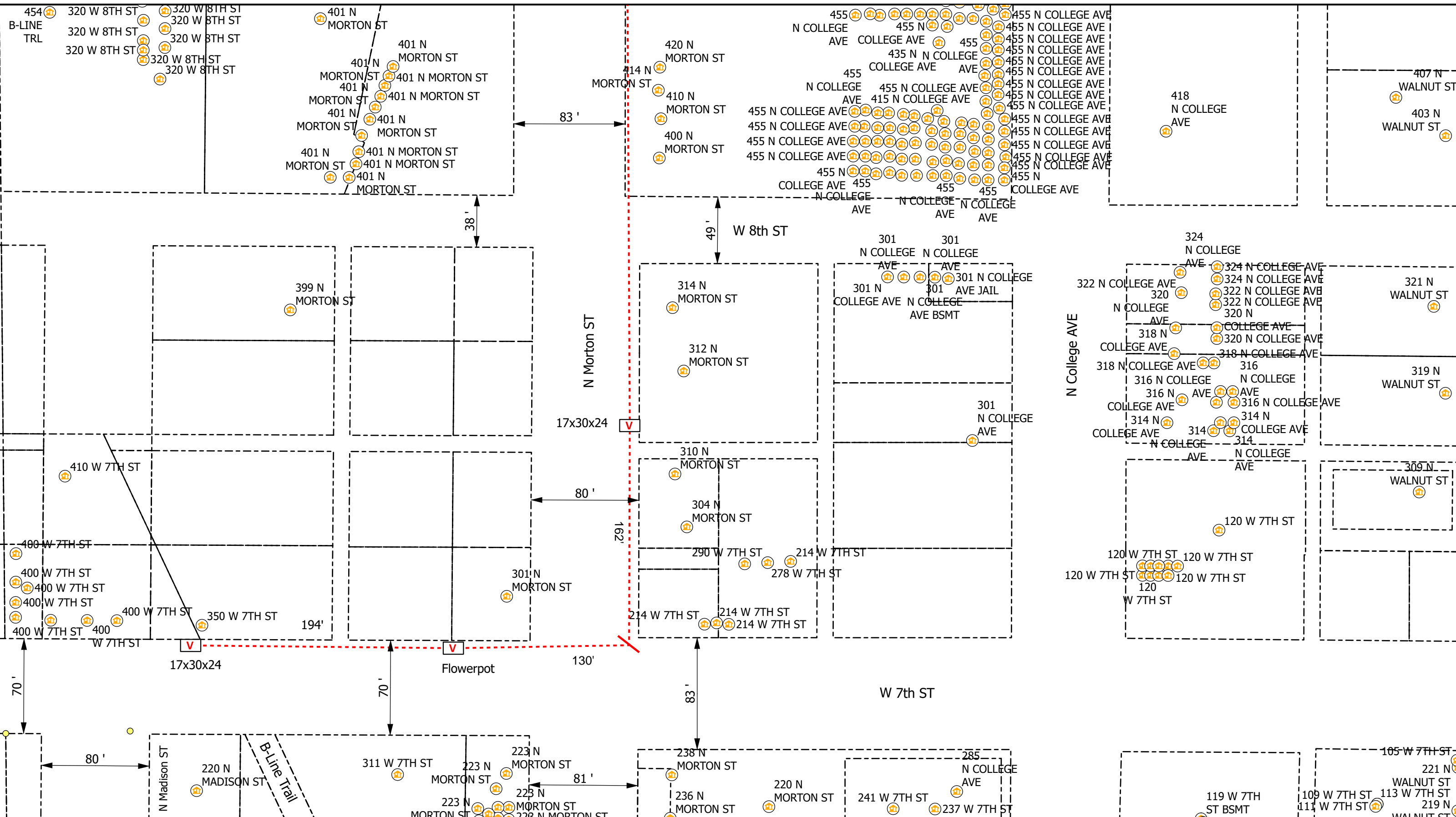

Legend

- Poles
- Risers
- Sidewalk
- Vaults
- Address
- Bloomington_Parcels
- Overhead Strand
- Anchor
- Grids
- Conduit

All Flowerpots 12" DIA

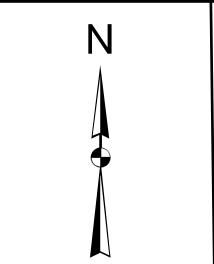

City of Bloomington, IN Permit:
Design View

INI	BY	DATE	DESCRIPTION



Print 9 of 11

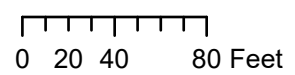
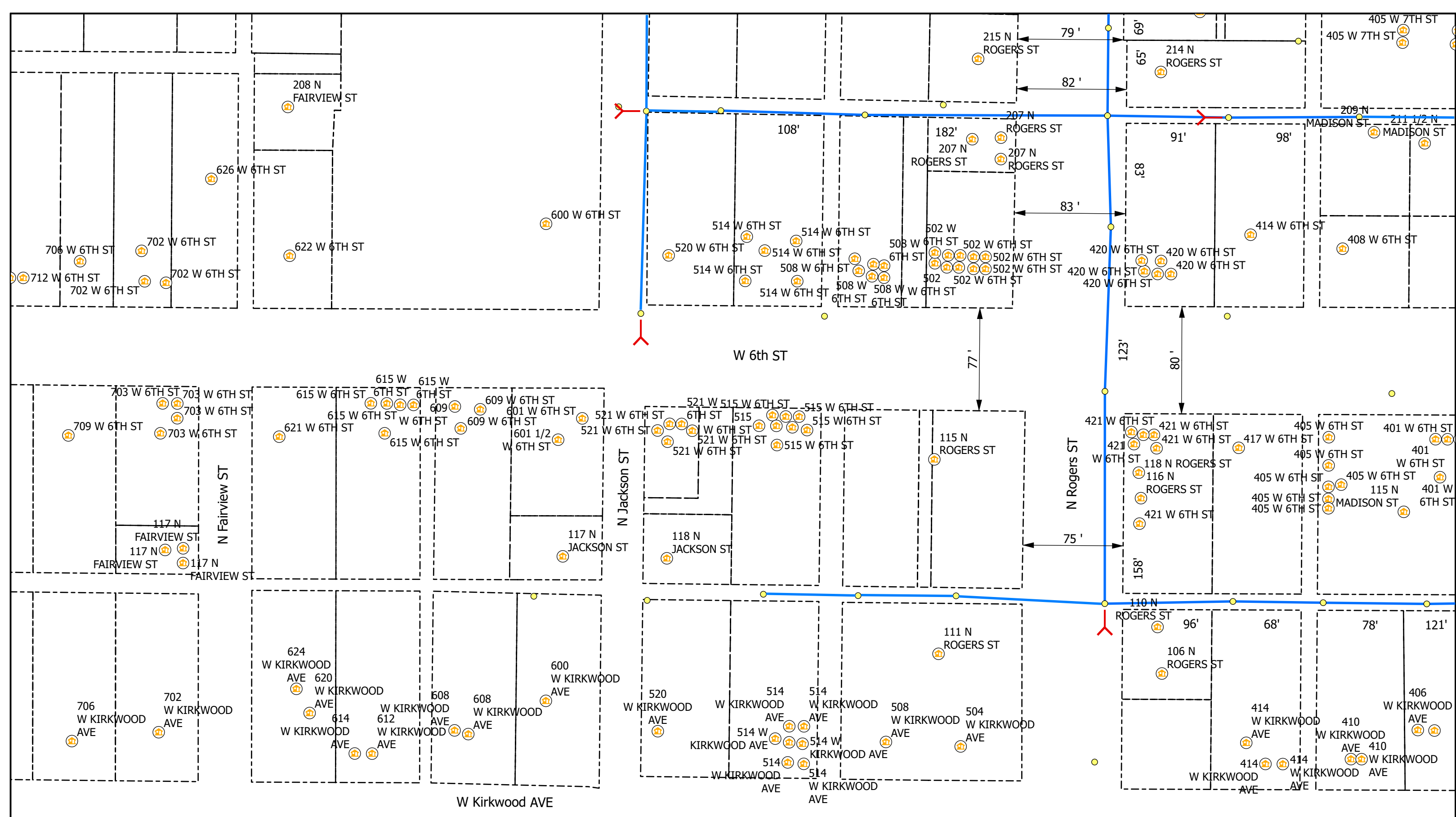

Legend

- Poles
- V Vaults
- Overhead Strand
- - - Conduit
- Ⓡ Risers
- 🏠 Address
- Y Anchor
- ↖ Sidewalk
- Bloomington_Parcels
- Grids

All Flowerpots 12" DIA



City of Bloomington, IN Permit:
Design View

INI	BY	DATE	DESCRIPTION



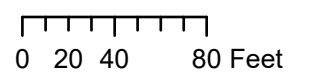
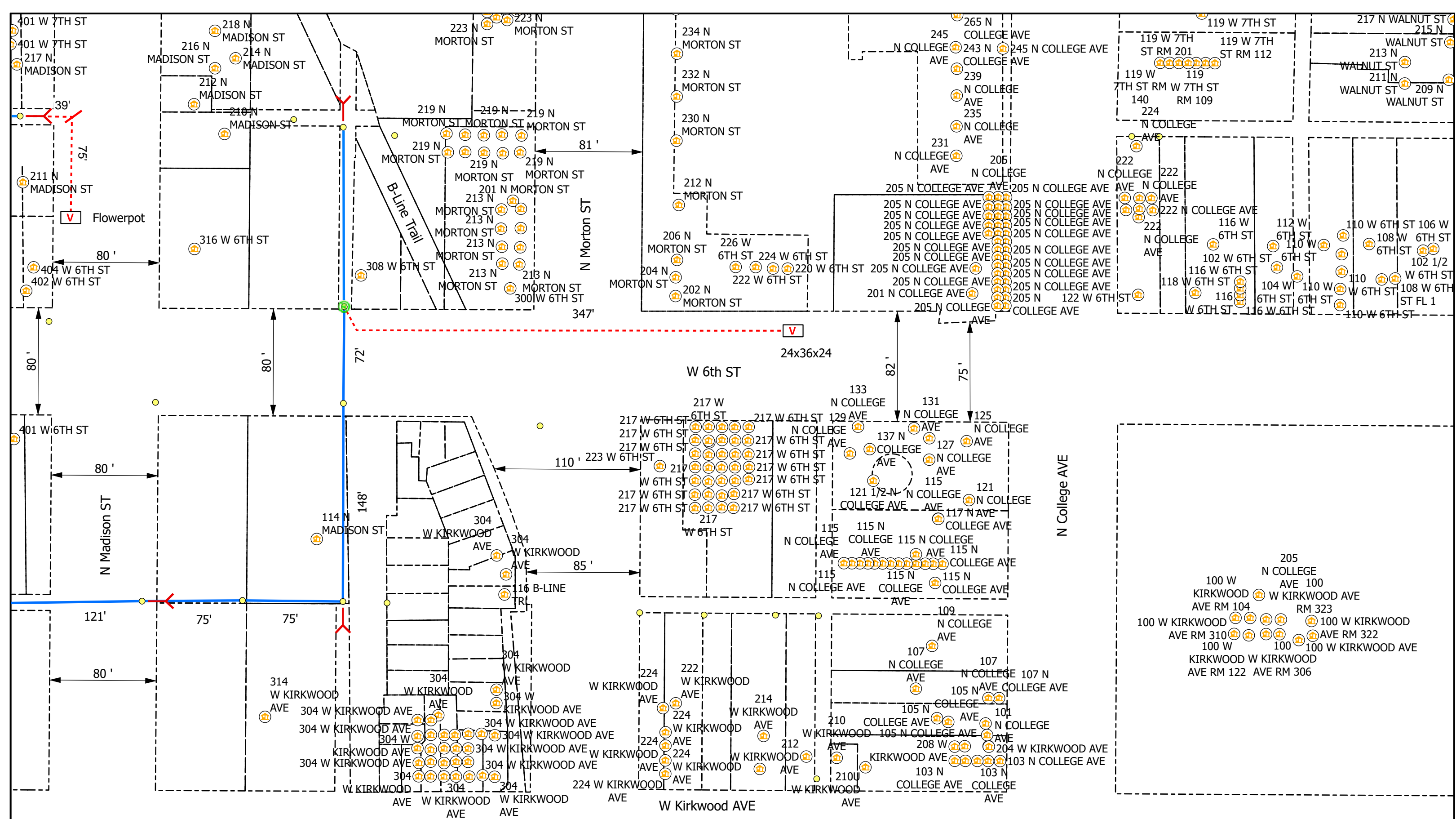

Legend

- Poles
- V Vaults
- Overhead Strand
- Conduit
- R Risers
- 🏠 Address
- Y Anchor
- ↖ Sidewalk
- Bloomington_Parcels
- Grids

All Flowerpots 12" DIA



City of Bloomington, IN Permit:
Design View

INI	BY	DATE	DESCRIPTION



Carlton® PV-Mold® Nonmetallic Pole Riser System

Carlton PV-Mold is a nonmetallic pole riser system designed to protect communications power cable installed on poles.

Features:

- Meets or exceeds requirements outlined in the National Electric Safety Code (NESC).
- Designed in accordance with NEMA TC-19 specifications.
- Ultraviolet, cold temperature and corrosive atmosphere resistant.
- Schedule 40 wall meets Schedule 80 PVC conduit impact requirements per NEMA TC-19.
- No grounding required.
- Belled end fits over each added section or conduit.
- Flame retardant.
- Requires no maintenance.
- PV-Mold acts as an insulator against electrical shock.
- Interchangeable parts and accessories to match the needs of specific requirements.



Steel U-Guard requires grounding strapping and does not have belled ends.



PV-Mold has belled ends, flanged design and does not require grounding.

Flanged Overall Length 10 Feet, Including Bell

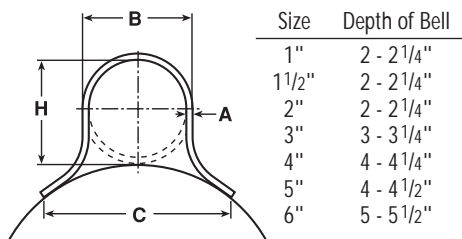

Slots are 1/2" from side to side, and allow for expansion and contraction.

Slot Dimensions: for sizes 2" through 6" are 5/16" wide, 3/4" long.

Slot Dimensions: for 1" and 1 1/2" are 3/16" wide, 3/4" long.

Slot Spacing: 18" from center, beginning 6" from end.

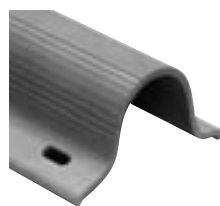

Standard Duty

Part No.	Size	Std. Ctn. Qty.	Std. Ctn. Wt. (lbs.)	Dimensions				Actual Impact @ 0°C 20 Pound Top
				A	B	C	H	
59208N	1"	294	1059	0.100"	1 5/8"	2 3/8"	1 5/8"	40 Ft.-Lbs.
59211N	2"	136	726	0.100"	2 3/8"	4 1/2"	2 3/8"	100 Ft.-Lbs.
59211X (5' length)	2"	136	363	0.100"	2 3/8"	4 1/2"	2 3/8"	100 Ft.-Lbs.
59213N	3"	66	761	0.150"	3 1/2"	6"	3 1/2"	110 Ft.-Lbs.
59213X (5' length)	3"	66	381	0.150"	3 1/2"	6"	3 1/2"	100 Ft.-Lbs.
59215N	4"	65	910	0.150"	4 1/2"	6 1/2"	4 1/2"	110 Ft.-Lbs.
59216N	5"	30	515	0.150"	5 1/2"	7 1/2"	5 1/2"	110 Ft.-Lbs.

Heavy Duty Schedule 40

59010N	1 1/2"	200	1142	0.145"	1 29/32"	3 1/2"	1 29/32"	100 Ft.-Lbs.
59011N	2"	136	1214	0.154"	2 3/8"	4 1/2"	2 3/8"	150 Ft.-Lbs.
59013N	3"	66	937	0.216"	3 1/2"	6"	3 9/32"	150 Ft.-Lbs.
59015N	4"	65	1621	0.237"	4 1/2"	6 1/2"	4 1/2"	260 Ft.-Lbs.
59015X (5' length)	4"	65	707	0.237"	4 1/2"	6 1/2"	4 1/2"	260 Ft.-Lbs.
59016N	5"	30	870	0.258"	5 1/2"	7 1/2"	5 1/2"	260 Ft.-Lbs.
59017N	6"	30	1160	0.280"	6 5/8"	8 3/4"	6 5/8"	260 Ft.-Lbs.

Extra Heavy Duty Schedule 80

59411N	2"	136	1549	0.218"	2 3/8"	4 1/2"	2 3/8"	300 Ft.-Lbs.
59413N	3"	66	1495	0.030"	3 1/2"	6"	3 1/2"	525 Ft.-Lbs.

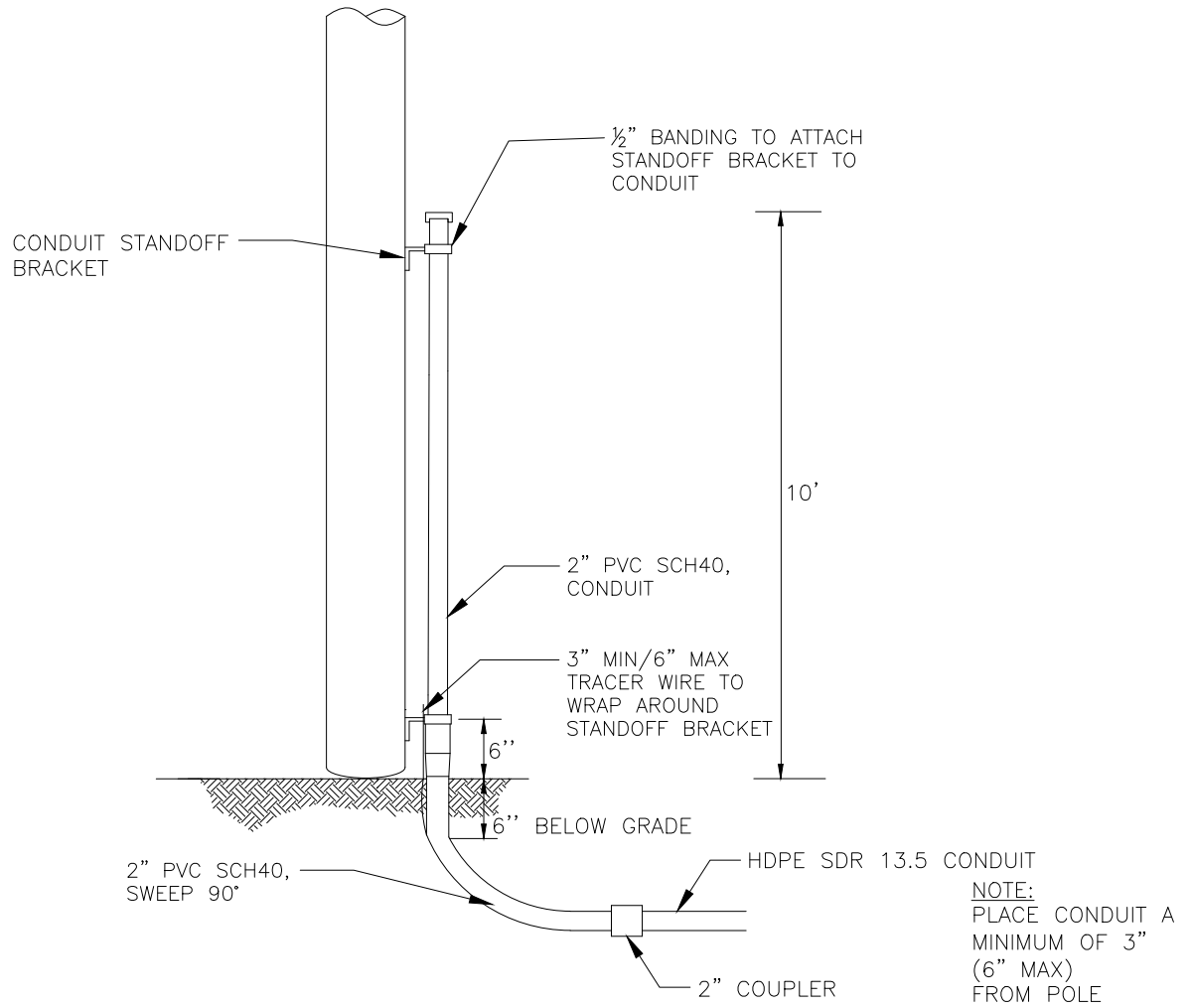

DESCRIPTION	QTY	MANUFACTURER (PREFERRED)	PART #
SCREW, LAG, 1/2" x 4-1/2"	10		
HDPE SDR 13.5 CONDUIT, VARIOUS SIZES	N/A		
2" PVC SCH40, RISER PIPE	1		
#12 TRACER WIRE	N/A		
2" PVC SCH40, SWEEP, 90 DEG	1		
CONDUIT STANDOFF BRACKET	VARIES		
CONDUIT STRAP KIT	VARIES		
2" COUPLER	1		



TYPICAL RISER
CONDUIT
WOOD POLE

(R2-W)

CONCEPTUAL SIDE VIEW

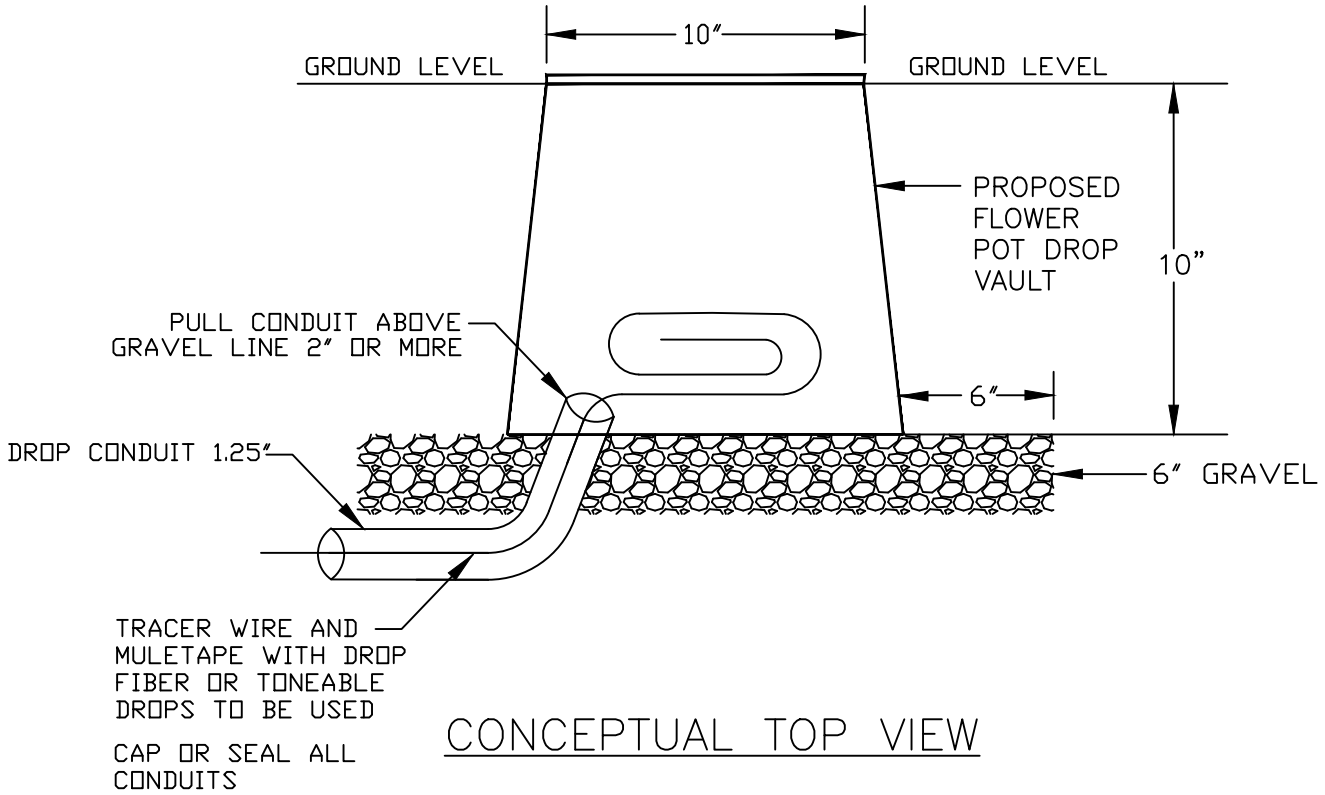

CONCEPTUAL TOP VIEW

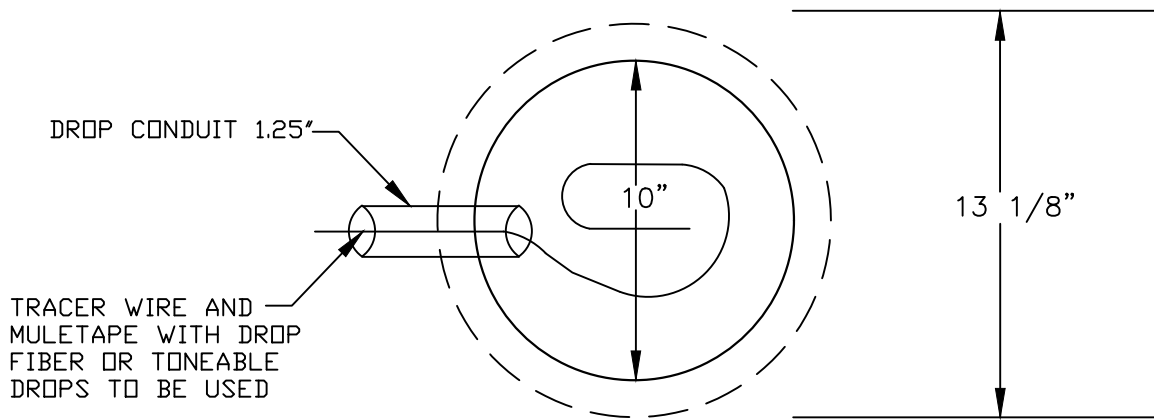

FLOWER POT

30"x48" PC UNIT, 2PC TIER 15/22
 18", 24", and 36" HEIGHT



AMERICAN POLYMER COMPANY

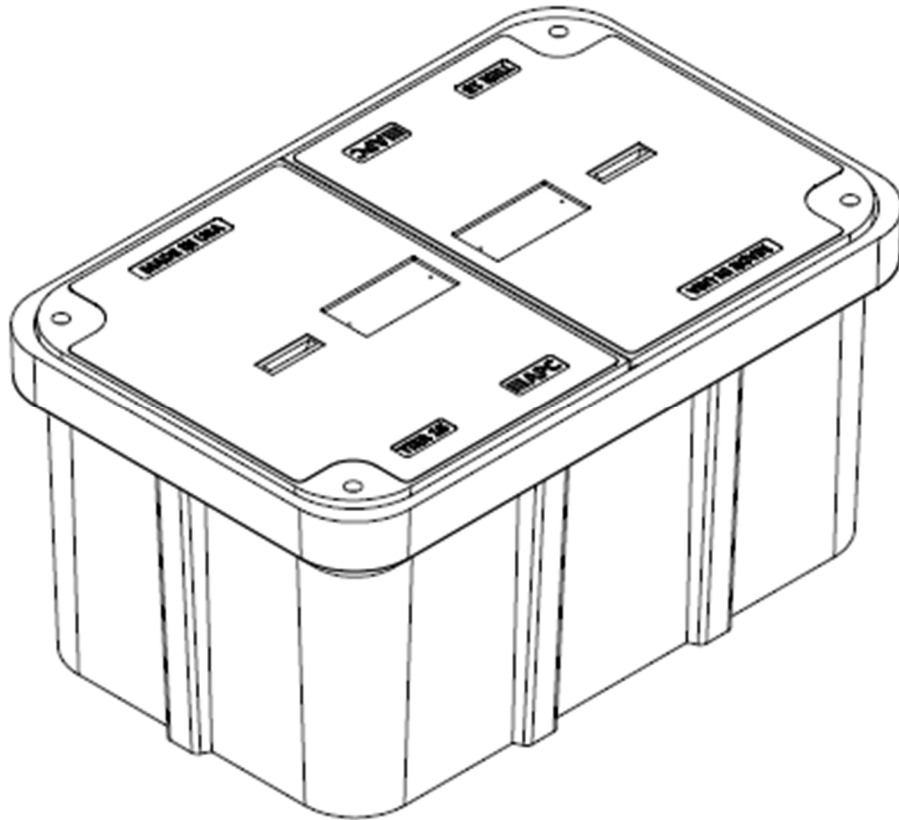

Description	Nominal Size	ANSI Tier	Part Number	Estimated Weight
PC Unit – TIER 15	30"x48"x18"	Tier 15	P304818HU15...	460 lbs.
PC Unit – TIER 22	30"x48"x18"	Tier 22	P304818HU22...	525 lbs.
PC Unit – TIER 15	30"x48"x24"	Tier 15	P304824HU15...	510 lbs.
PC Unit – TIER 22	30"x48"x24"	Tier 22	P304824HU22...	575 lbs.
PC Unit – TIER 15	30"x48"x36"	Tier 15	P304836HU15...	615 lbs.
PC Unit – TIER 22	30"x48"x36"	Tier 22	P304836HU22...	680 lbs.



30"x48" PC UNIT, 2PC TIER 15/22

18", 24", and 36" HEIGHT



AMERICAN POLYMER COMPANY

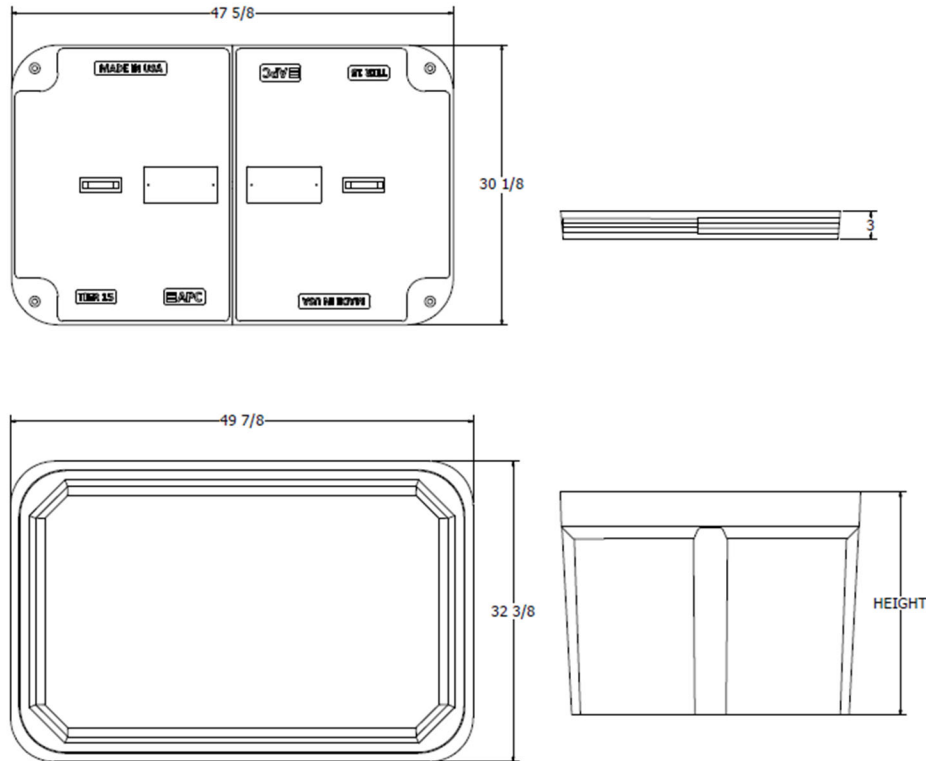

Components	Nominal Size	ANSI Tier	Part Number	Estimated Weight
Replacement Box	30"x48"x18"	Tier 22	P304818B22	185 lbs.
Replacement Box	30"x48"x24"	Tier 22	P304824B22	235 lbs.
Replacement Box	30"x48"x36"	Tier 22	P304836B22	340 lbs.
Replacement Lids - T15	30"x48" (half)	Tier 15	Various	150 lbs.
Replacement Lids - T22	30"x48" (half)	Tier 22	Various	170 lbs.

Bolt options

Hex Head



Machine Thread



Penta Head



Auger Thread



24"x36" PC UNIT, TIER 15/22
 18", 24", 30", and 36" HEIGHT



AMERICAN POLYMER COMPANY

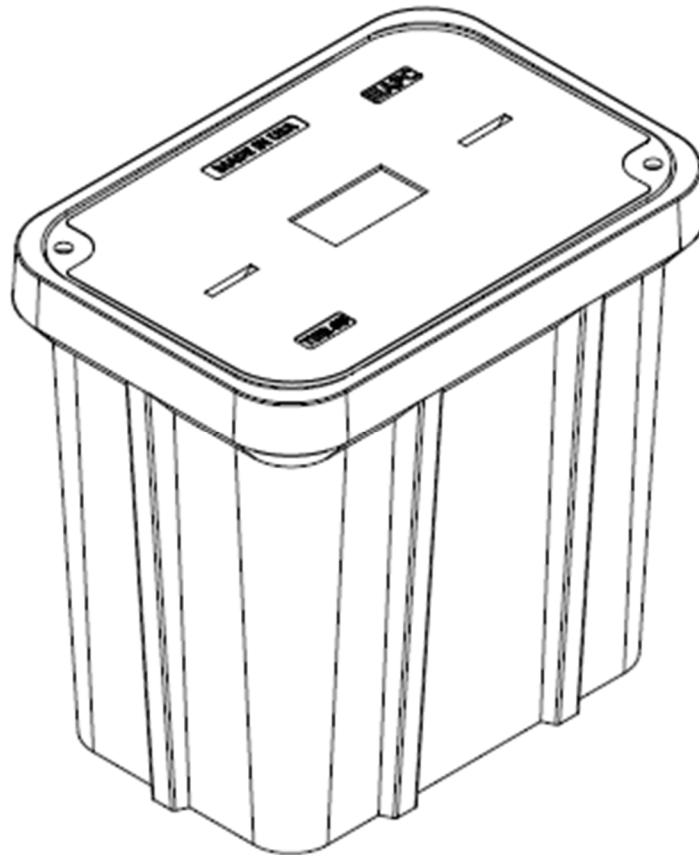

Description	Nominal Size	ANSI Tier	Part Number	Estimated Weight
PC Unit – TIER 15	24x36"x18"	Tier 15	P243618U15...	335 lbs.
PC Unit – TIER 22	24x36"x18"	Tier 22	P243618U22...	355 lbs.
PC Unit – TIER 15	24x36"x24"	Tier 15	P243624U15...	365 lbs.
PC Unit – TIER 22	24x36"x24"	Tier 22	P243624U22...	385 lbs.
PC Unit – TIER 15	24x36"x30"	Tier 15	P243630U15...	395 lbs.
PC Unit – TIER 22	24x36"x30"	Tier 22	P243630U22...	415 lbs.
PC Unit – TIER 15	24x36"x36"	Tier 15	P243636U15...	425 lbs.
PC Unit – TIER 22	24x36"x36"	Tier 22	P243636U22...	445 lbs.



24"x36" PC UNIT, TIER 15/22

18", 24", 30", and 36" HEIGHT



AMERICAN POLYMER COMPANY

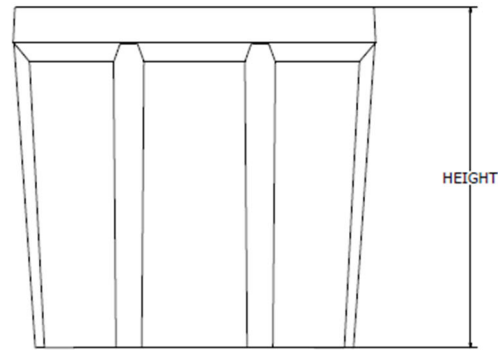
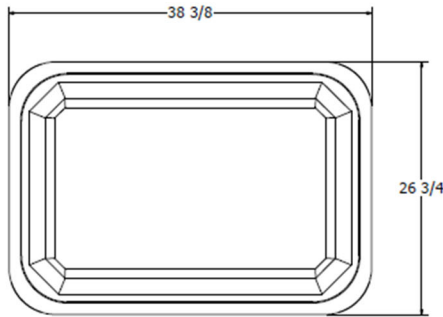
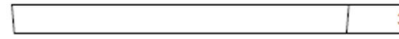
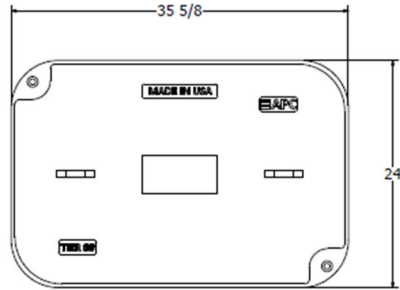

Components	Nominal Size	ANSI Tier	Part Number	Estimated Weight
Replacement Box	24"x36"x18"	Tier 22	P243618B22	165 lbs.
Replacement Box	24"x36"x24"	Tier 22	P243624B22	195 lbs.
Replacement Box	24"x36"x30"	Tier 22	P243630B22	225 lbs.
Replacement Box	24"x36"x36"	Tier 22	P243636B22	255 lbs.
Replacement Lids - T15	24"x36"	Tier 15	Various	170 lbs.
Replacement Lids - T22	24"x36"	Tier 22	Various	190 lbs.

Bolt options

Hex Head



Machine Thread



Penta Head



Auger Thread



17"x30" PC UNIT, TIER 15/22

12", 18", 24", and 30" HEIGHT



AMERICAN POLYMER COMPANY

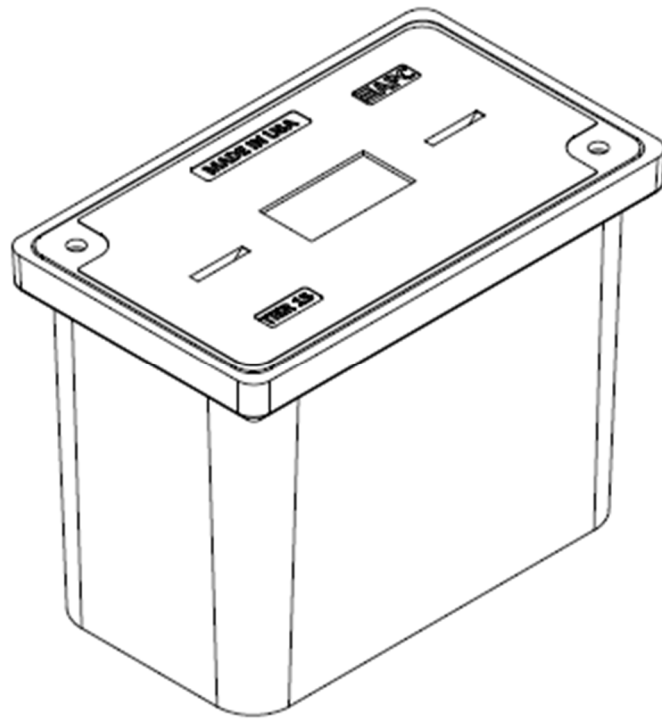

Description	Nominal Size	ANSI Tier	Part Number	Estimated Weight
PC Unit – TIER 15	17"x30"x12"	Tier 15	P173012U15...	138 lbs.
PC Unit – TIER 22	17"x30"x12"	Tier 22	P173012U22...	147 lbs.
PC Unit – TIER 15	17"x30"x18"	Tier 15	P173018U15...	172 lbs.
PC Unit – TIER 22	17"x30"x18"	Tier 22	P173018U22...	181 lbs.
PC Unit – TIER 15	17"x30"x24"	Tier 15	P173024U15...	192 lbs.
PC Unit – TIER 22	17"x30"x24"	Tier 22	P173024U22...	201 lbs.
PC Unit – TIER 15	17"x30"x30"	Tier 15	P173030U15...	217 lbs.
PC Unit – TIER 22	17"x30"x30"	Tier 22	P173030U22...	226 lbs.



17"x30" PC UNIT, TIER 15/22

12", 18", 24", and 30" HEIGHT



AMERICAN POLYMER COMPANY

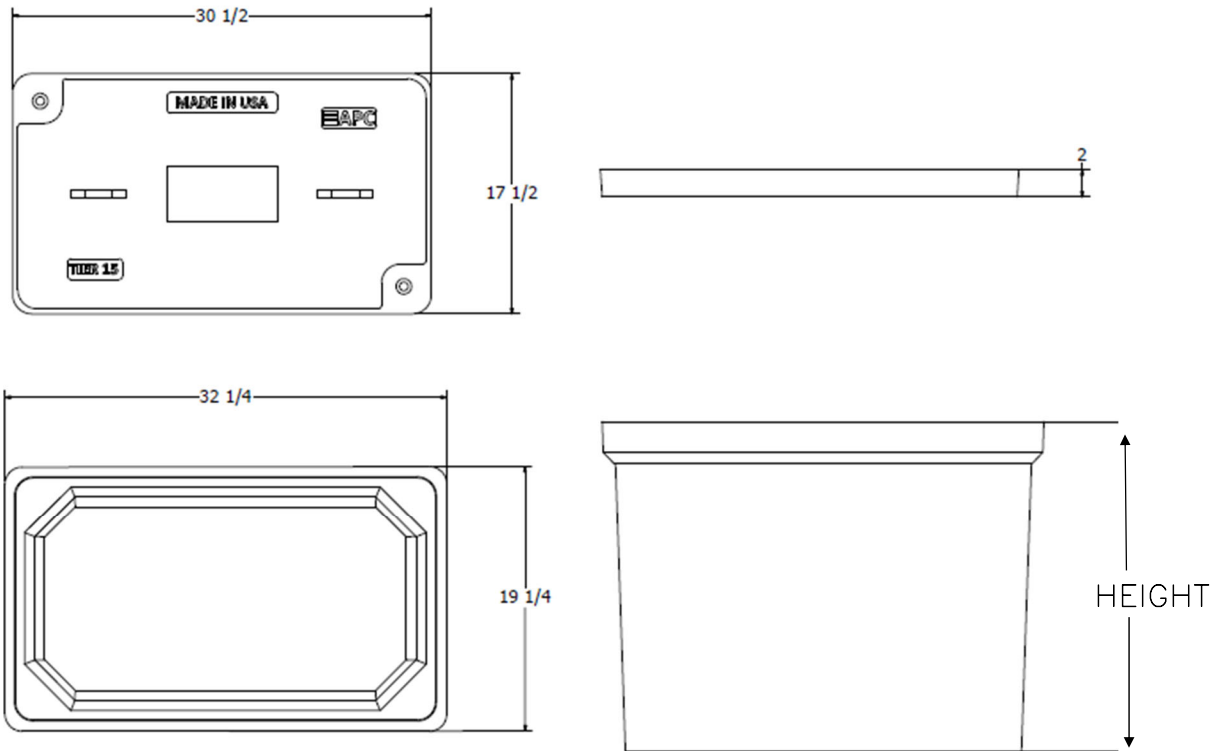

Components	Nominal Size	ANSI Tier	Part Number	Estimated Weight
Replacement Box	17"x30"x12"	Tier 22	P173012B22	66 lbs.
Replacement Box	17"x30"x18"	Tier 22	P173018B22	100 lbs.
Replacement Box	17"x30"x24"	Tier 22	P173024B22	120 lbs.
Replacement Box	17"x30"x30"	Tier 22	P173030B22	145 lbs.
Replacement Lids – T15	17"x30"	Tier 15	Various	72 lbs.
Replacement Lids – T22	17"x30"	Tier 22	Various	81 lbs.

Bolt options



Machine Thread



Auger Thread



33"x60" PC UNIT, 2PC TIER 15/22
36" HEIGHT



AMERICAN POLYMER COMPANY

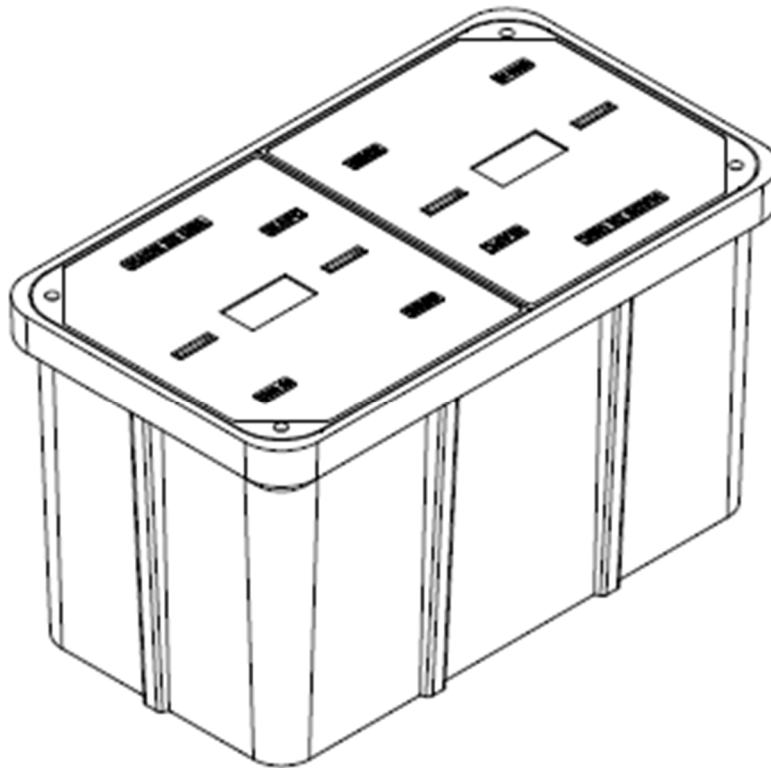

Description	Nominal Size	ANSI Tier	Part Number	Estimated Weight
PC Unit - TIER 15	33"x60"x36"	Tier 15	P336036U15...	930 lbs.
PC Unit - TIER 22	33"x60"x36"	Tier 22	P336036U22...	1030 lbs.



33"x60" PC UNIT, 2PC TIER 15/22

36" HEIGHT



AMERICAN POLYMER COMPANY

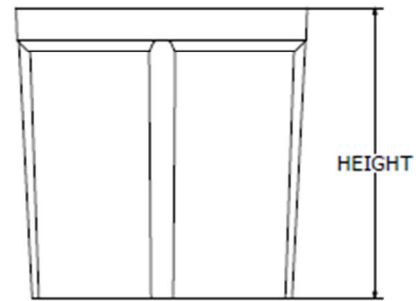
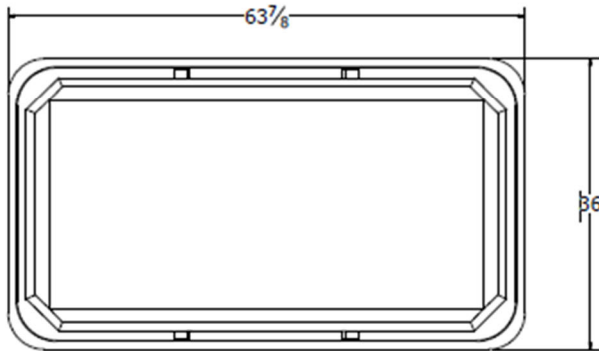
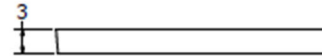

Components	Nominal Size	ANSI Tier	Part Number	Estimated Weight
Replacement Box	33"x60"x36"	Tier 22	P336036B22	530 lbs.
Replacement Lids - T15	33"x60" (half)	Tier 15	Various	200 lbs.
Replacement Lids - T22	33"x60" (half)	Tier 22	Various	250 lbs.

Bolt options

Hex Head



Machine Thread



Penta Head



Auger Thread



Speed (MPH) Prior To Road Work	SIGN SPACING, FT.		Must be Approved by an Engineer				
	Non-Divided Highways	Divided Highways	BUFFER SPACE, FT.	TAPER LENGTH, FT.	CHANNELIZING SPACING, FT.		
	Length	Shoulder (10 ft. Width)	Lane (12 ft. Width)	Through Taper	Through Buffer/Work Area		
0-35	200	200	250	70	245	35	50
40-45	350	500	360	150	540	40	80
50-55	500	1000	495	185	660	50	100
60-70	SA-1000, SB-1500, SC-2640		730	235	840	60	120
	Urban Low Speed - 100 FT						

APPROVED/ACCEPTED BY:
ENGINEER, OWNER, or PRIME CONTRACTOR
 Check for Notice to Proceed.

Signature: _____

Company: _____

Road Runner Safety Services, Inc.

Date: 8/9/2023 Project: BLN01b-F10 N Morton St - TCP1 :
Traffic Control Suggestion For: ATLANTIC ENGINEERING (AEG) :
By: Road Runner Safety Services, Inc. : Nathan

Comments:
Drawing not to scale. Traffic control plan must be approved by an engineer. This is a suggestion only. Road Runners Safety Services, Inc. has no liability for this suggested traffic control plan. Actual placement and spacing of all traffic control devices will depend on field conditions and must conform to MUTCD standards.

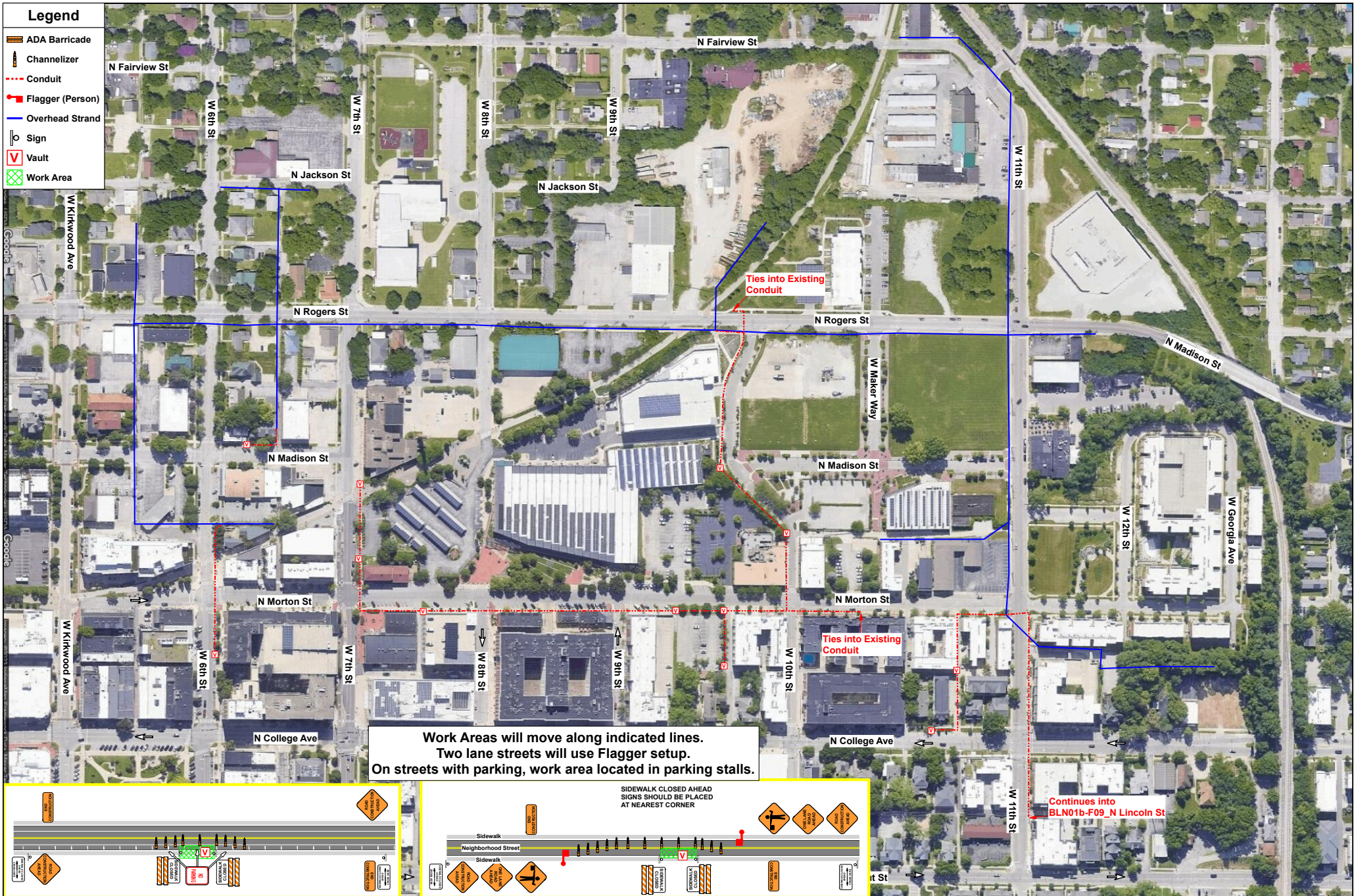

Work Areas will move along indicated lines.
Two lane streets will use Flagger setup.
On streets with parking, work area located in parking stalls.

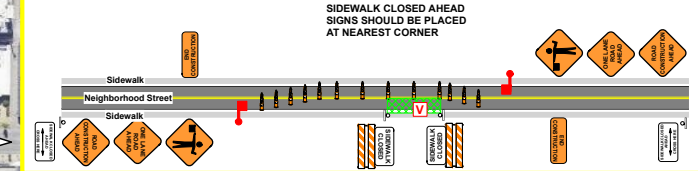
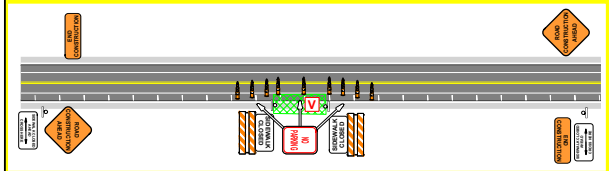

SIDEWALK CLOSED AHEAD
SIGNS SHOULD BE PLACED
AT NEAREST CORNER

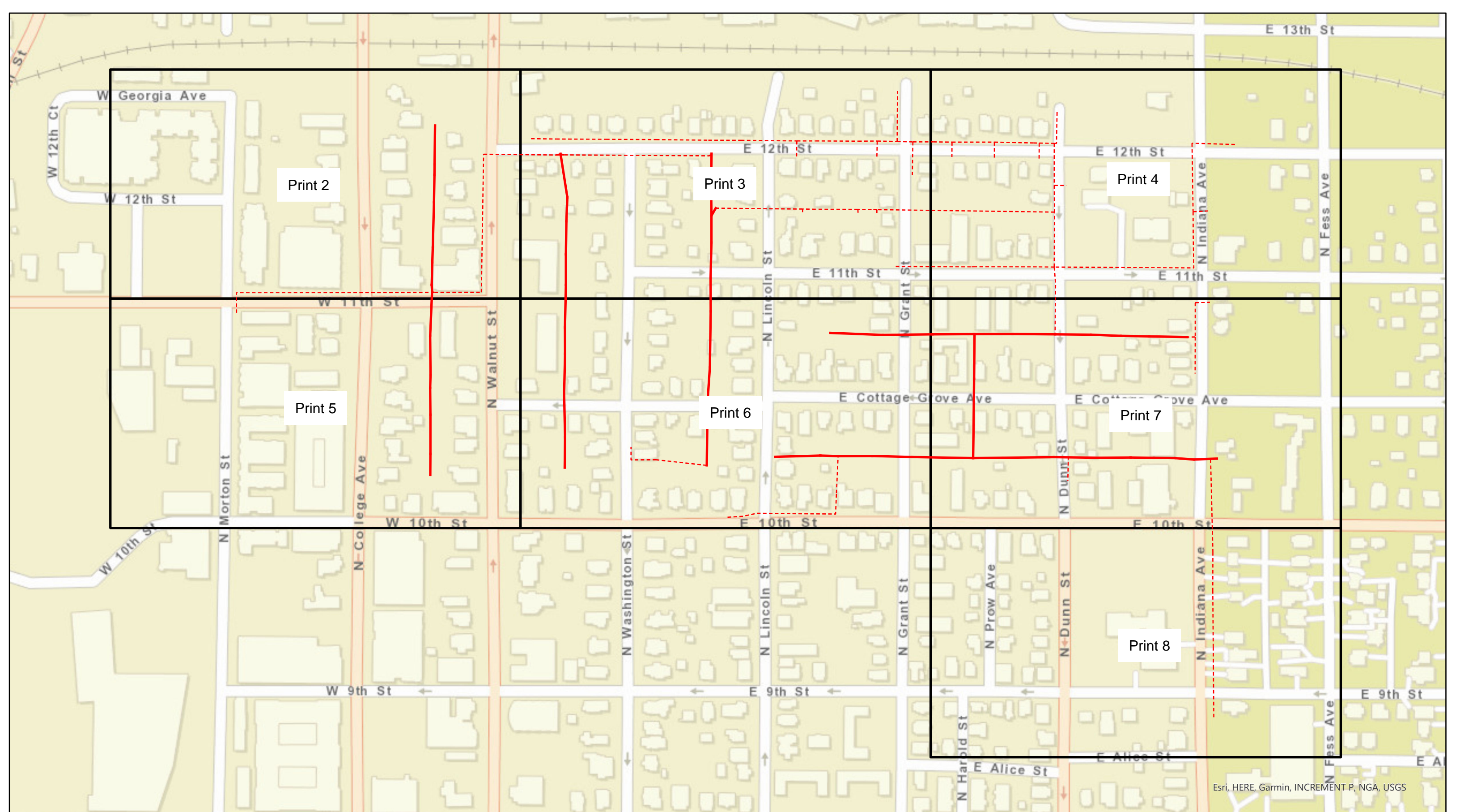

Legend BLN01b-F09_N Lincoln St

- Overhead Strand
- - - Conduit
- Grids



City of Bloomington, IN Permit:
Design View

INI	BY	DATE	DESCRIPTION

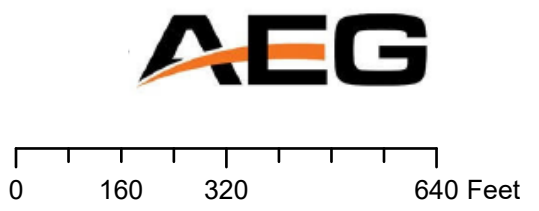

Esri, HERE, Garmin, INCREMENT P, NGA, USGS

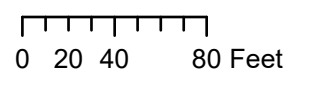
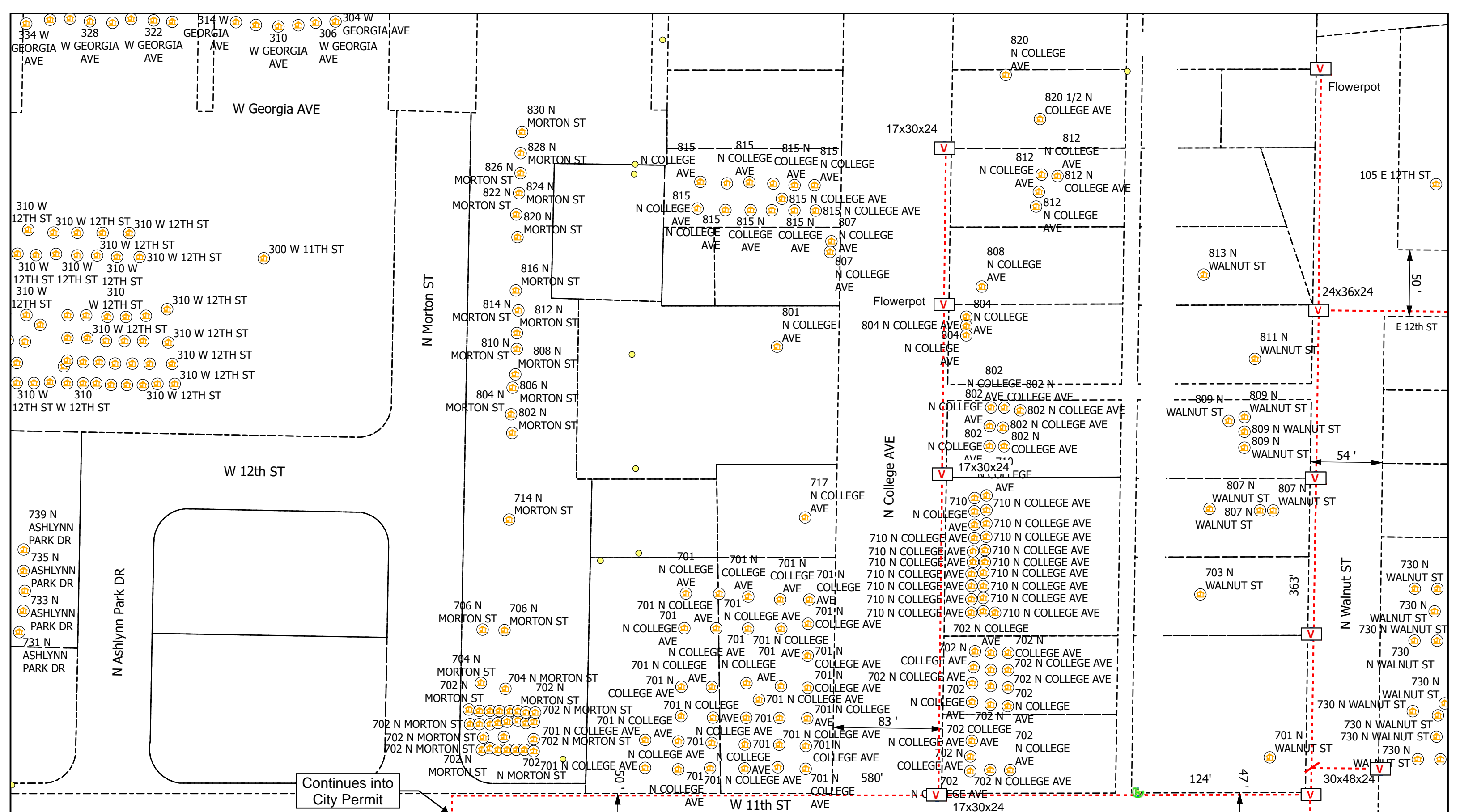

Legend

- Poles
- V Vaults
- Overhead Strand
- Conduit
- Risers
- Address
- Y Anchor
- ↖ Sidewalk
- Bloomington_Parcels
- Grids

All Flowerpots 12" DIA



City of Bloomington, IN Permit:
Design View

INI	BY	DATE	DESCRIPTION



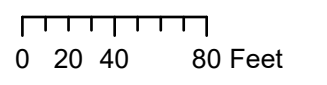
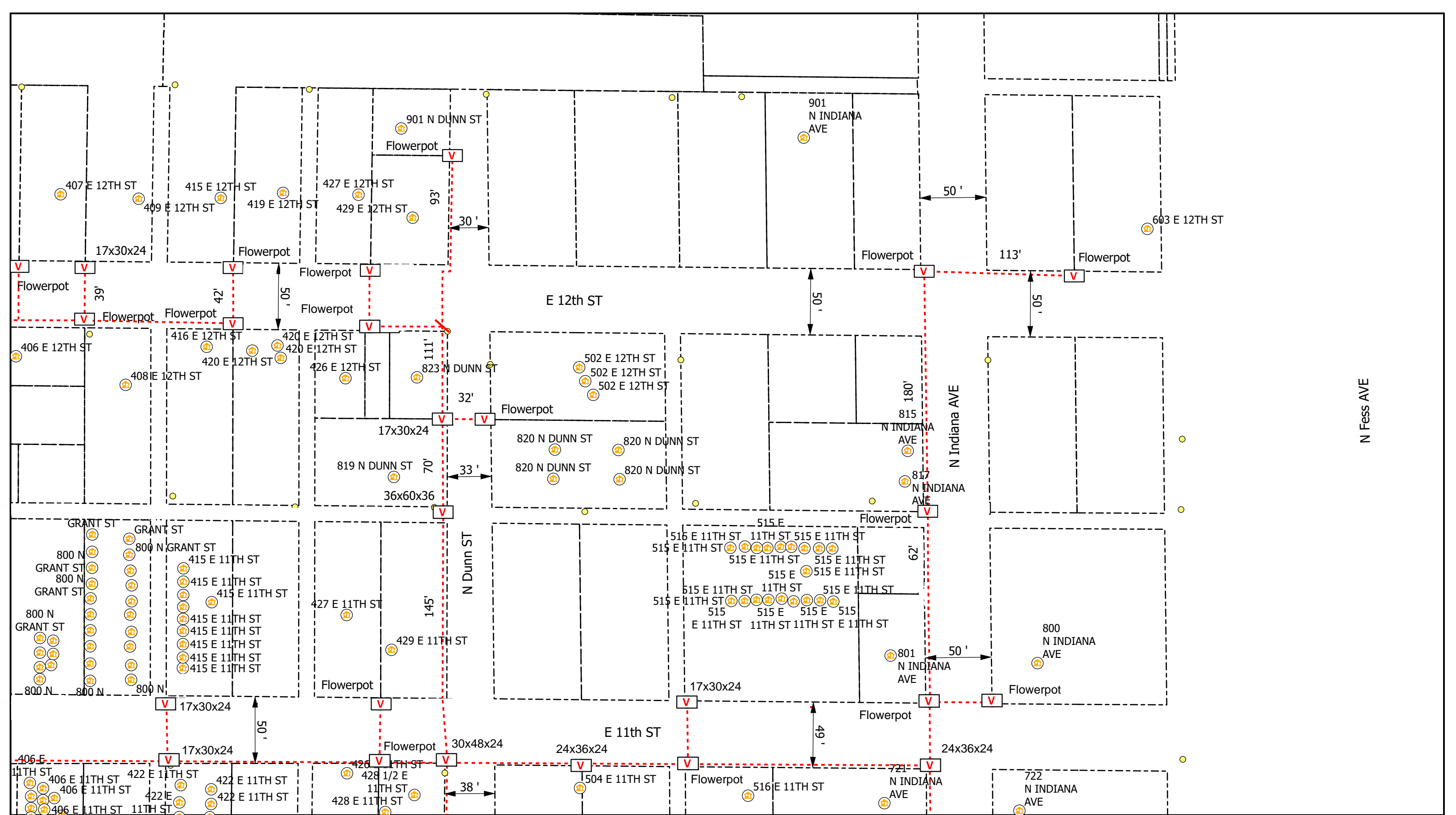

Legend

- Poles
- V Vaults
- Overhead Strand
- - - Conduit
- Ⓡ Risers
- Ⓜ Address
- Y Anchor
- ↖ Sidewalk
- Bloomington_Parcels
- Grids

All Flowerpots 12" DIA



City of Bloomington, IN Permit:
Design View

INI	BY	DATE	DESCRIPTION



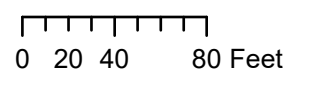
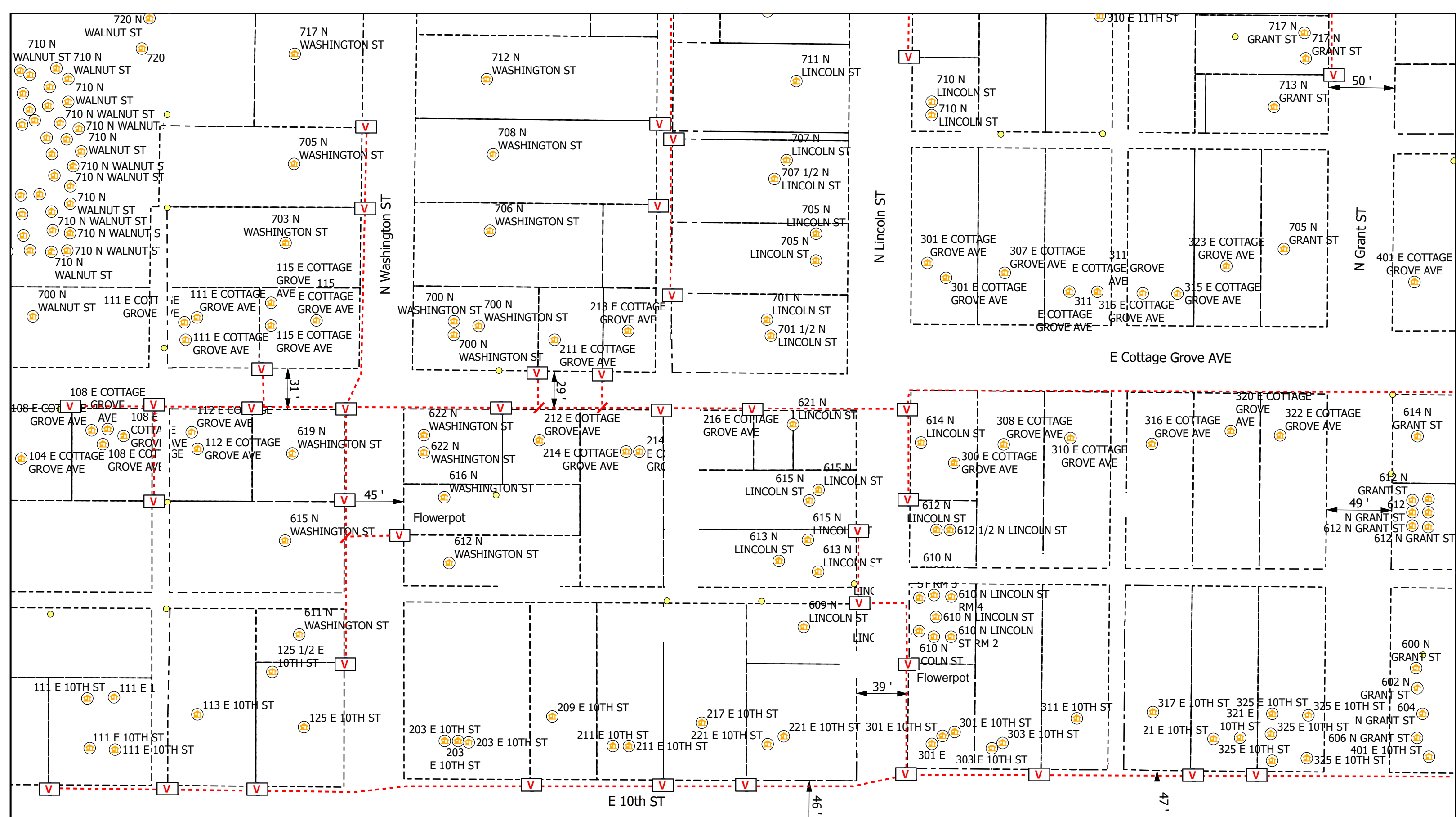

Legend

- Poles
- V Vaults
- Overhead Strand
- Conduit
- R Risers
- 🏠 Address
- Y Anchor
- ↖ Sidewalk
- Bloomington_Parcels
- Grids

All Flowerpots 12" DIA



City of Bloomington, IN Permit:
Design View

INI	BY	DATE	DESCRIPTION



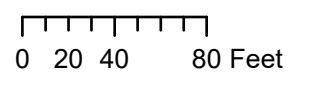
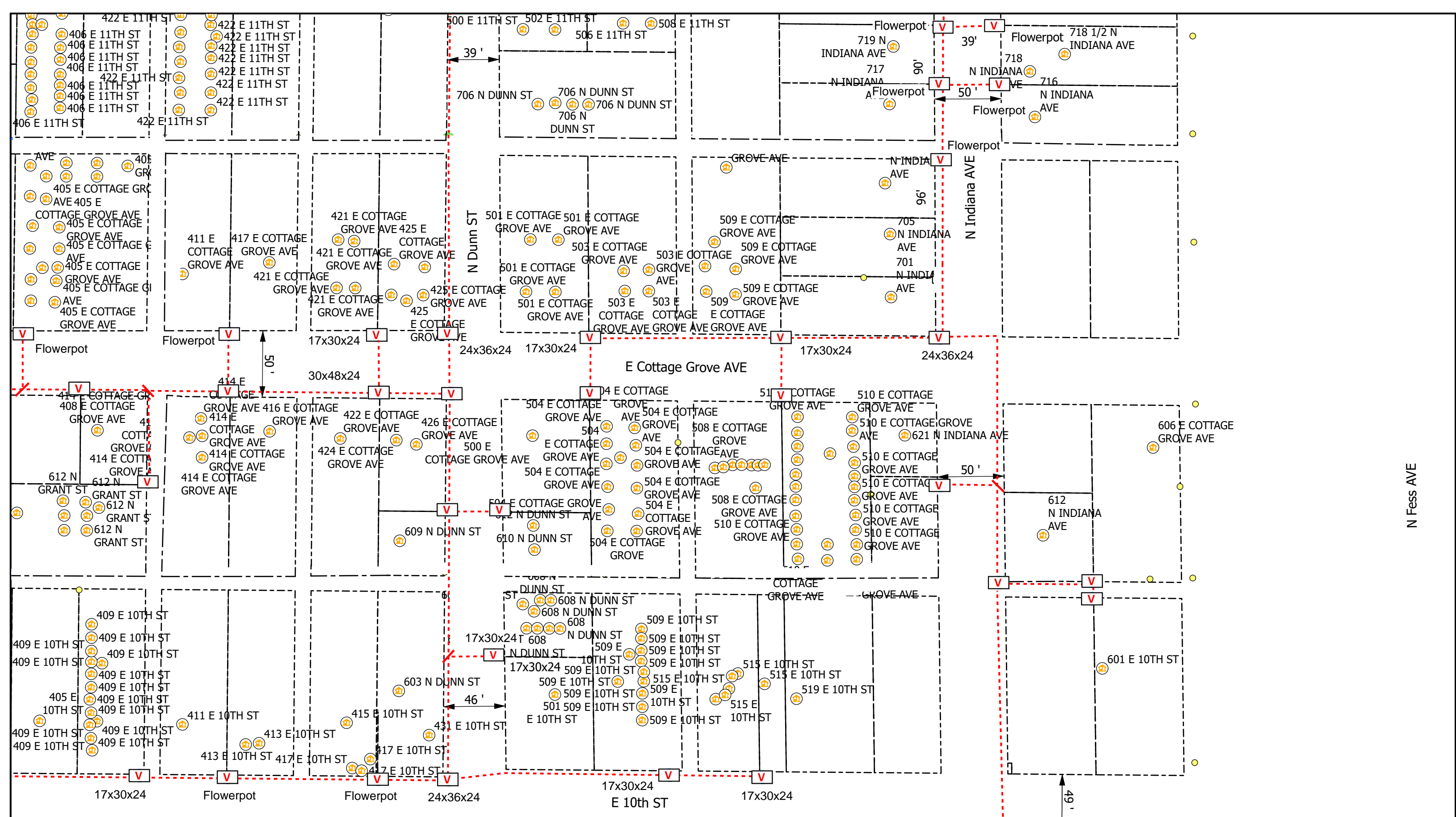

Legend

- Poles
- V Vaults
- Overhead Strand
- Conduit
- R Risers
- ⊙ Address
- Y Anchor
- ↖ Sidewalk
- Bloomington_Parcels
- Grids

All Flowerpots 12" DIA



City of Bloomington, IN Permit:
Design View

INI	BY	DATE	DESCRIPTION



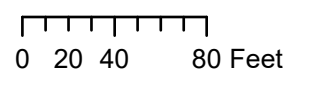
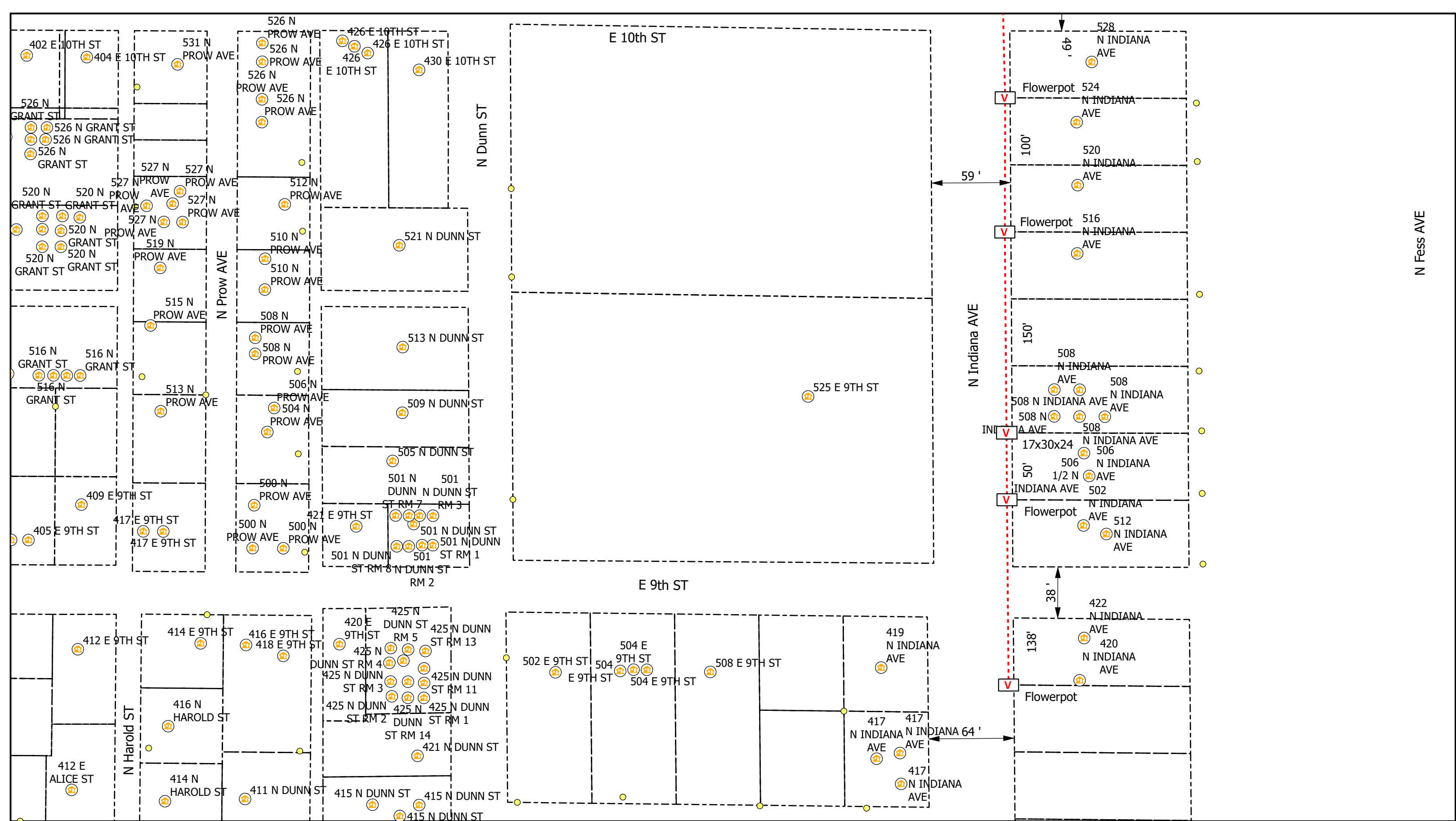

Legend

- Poles
- Ⓥ Vaults
- Overhead Strand
- - - Conduit
- Ⓡ Risers
- Ⓢ Address
- ⋈ Anchor
- ↶ Sidewalk
- Bloomington_Parcels
- Grids

All Flowerpots 12" DIA



City of Bloomington, IN Permit:
Design View

INI	BY	DATE	DESCRIPTION



Carlton® PV-Mold® Nonmetallic Pole Riser System

Carlton PV-Mold is a nonmetallic pole riser system designed to protect communications power cable installed on poles.

Features:

- Meets or exceeds requirements outlined in the National Electric Safety Code (NESC).
- Designed in accordance with NEMA TC-19 specifications.
- Ultraviolet, cold temperature and corrosive atmosphere resistant.
- Schedule 40 wall meets Schedule 80 PVC conduit impact requirements per NEMA TC-19.
- No grounding required.
- Belled end fits over each added section or conduit.
- Flame retardant.
- Requires no maintenance.
- PV-Mold acts as an insulator against electrical shock.
- Interchangeable parts and accessories to match the needs of specific requirements.



Steel U-Guard requires grounding strapping and does not have belled ends.



PV-Mold has belled ends, flanged design and does not require grounding.

Flanged Overall Length 10 Feet, Including Bell

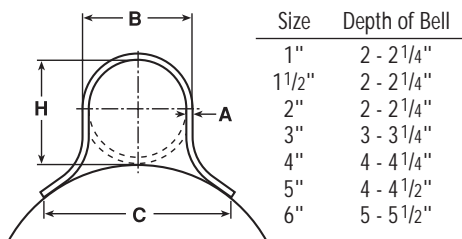

Slots are 1/2" from side to side, and allow for expansion and contraction.

Slot Dimensions: for sizes 2" through 6" are 5/16" wide, 3/4" long.

Slot Dimensions: for 1" and 1 1/2" are 3/16" wide, 3/4" long.

Slot Spacing: 18" from center, beginning 6" from end.



Standard Duty

Part No.	Size	Std. Ctn. Qty.	Std. Ctn. Wt. (lbs.)	Dimensions				Actual Impact @ 0°C 20 Pound Top
				A	B	C	H	
59208N	1"	294	1059	0.100"	1 5/8"	2 3/8"	1 5/8"	40 Ft.-Lbs.
59211N	2"	136	726	0.100"	2 3/8"	4 1/2"	2 3/8"	100 Ft.-Lbs.
59211X (5' length)	2"	136	363	0.100"	2 3/8"	4 1/2"	2 3/8"	100 Ft.-Lbs.
59213N	3"	66	761	0.150"	3 1/2"	6"	3 1/2"	110 Ft.-Lbs.
59213X (5' length)	3"	66	381	0.150"	3 1/2"	6"	3 1/2"	100 Ft.-Lbs.
59215N	4"	65	910	0.150"	4 1/2"	6 1/2"	4 1/2"	110 Ft.-Lbs.
59216N	5"	30	515	0.150"	5 1/2"	7 1/2"	5 1/2"	110 Ft.-Lbs.

Heavy Duty Schedule 40

59010N	1 1/2"	200	1142	0.145"	1 29/32"	3 1/2"	1 29/32"	100 Ft.-Lbs.
59011N	2"	136	1214	0.154"	2 3/8"	4 1/2"	2 3/8"	150 Ft.-Lbs.
59013N	3"	66	937	0.216"	3 1/2"	6"	3 9/32"	150 Ft.-Lbs.
59015N	4"	65	1621	0.237"	4 1/2"	6 1/2"	4 1/2"	260 Ft.-Lbs.
59015X (5' length)	4"	65	707	0.237"	4 1/2"	6 1/2"	4 1/2"	260 Ft.-Lbs.
59016N	5"	30	870	0.258"	5 1/2"	7 1/2"	5 1/2"	260 Ft.-Lbs.
59017N	6"	30	1160	0.280"	6 5/8"	8 3/4"	6 5/8"	260 Ft.-Lbs.

Extra Heavy Duty Schedule 80

59411N	2"	136	1549	0.218"	2 3/8"	4 1/2"	2 3/8"	300 Ft.-Lbs.
59413N	3"	66	1495	0.030"	3 1/2"	6"	3 1/2"	525 Ft.-Lbs.

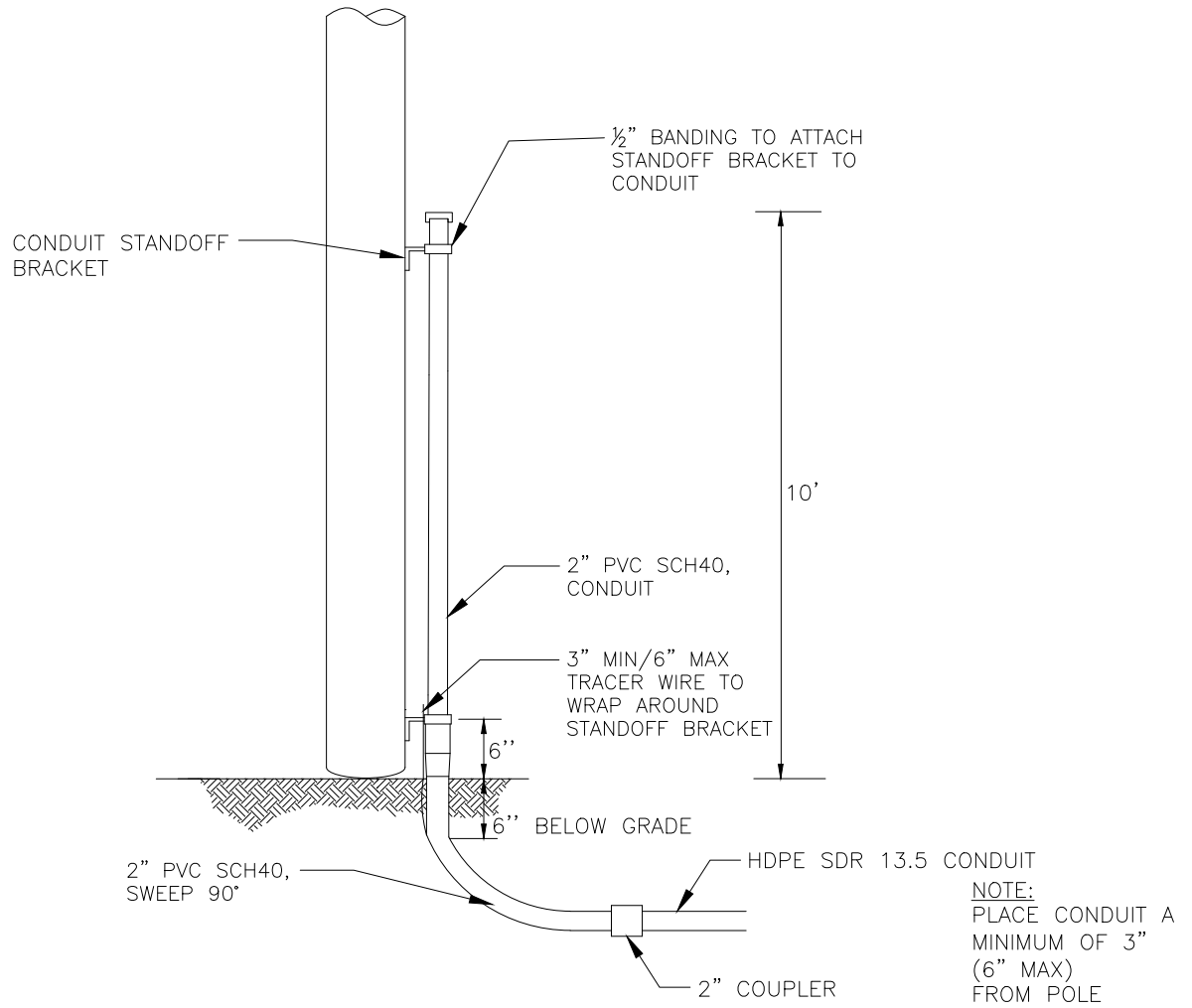

DESCRIPTION	QTY	MANUFACTURER (PREFERRED)	PART #
SCREW, LAG, 1/2" x 4-1/2"	10		
HDPE SDR 13.5 CONDUIT, VARIOUS SIZES	N/A		
2" PVC SCH40, RISER PIPE	1		
#12 TRACER WIRE	N/A		
2" PVC SCH40, SWEEP, 90 DEG	1		
CONDUIT STANDOFF BRACKET	VARIES		
CONDUIT STRAP KIT	VARIES		
2" COUPLER	1		



TYPICAL RISER
CONDUIT
WOOD POLE

(R2-W)

CONCEPTUAL SIDE VIEW

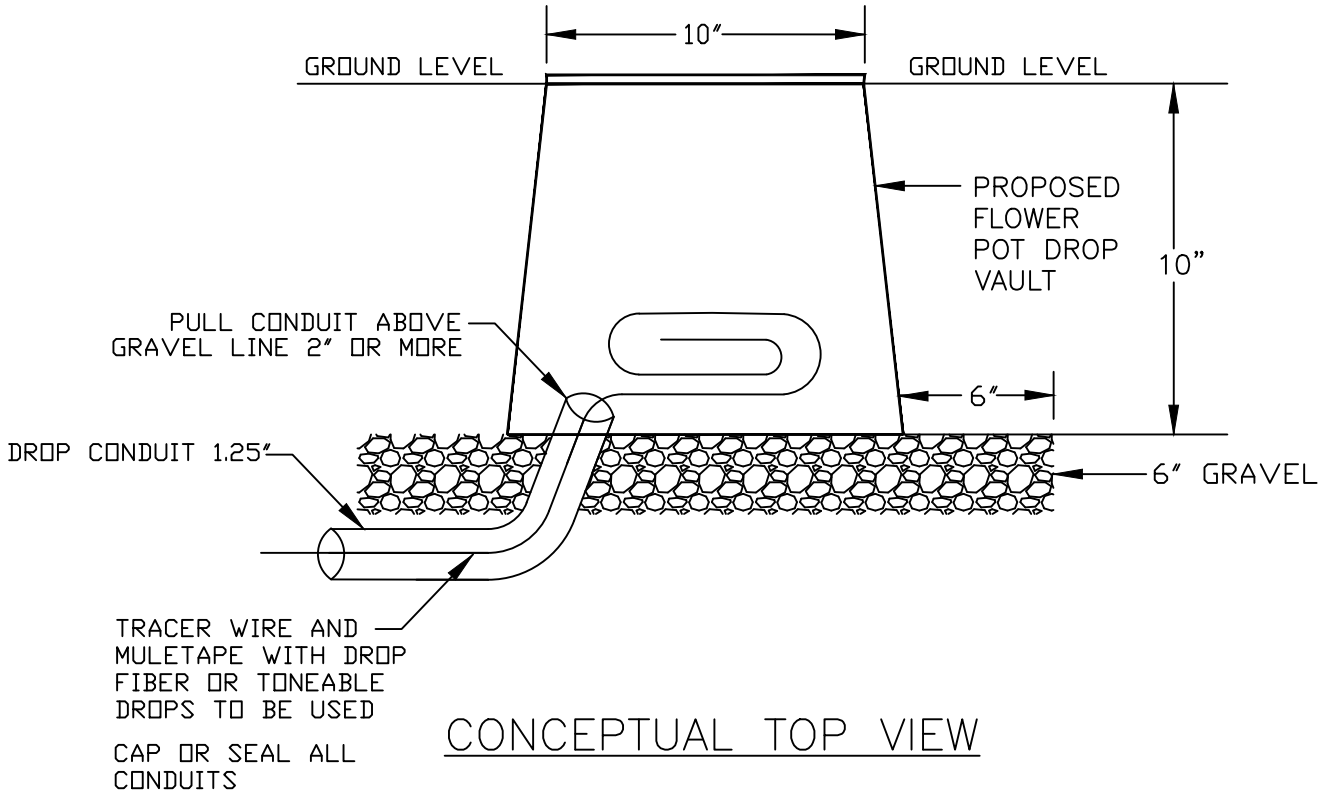

CONCEPTUAL TOP VIEW

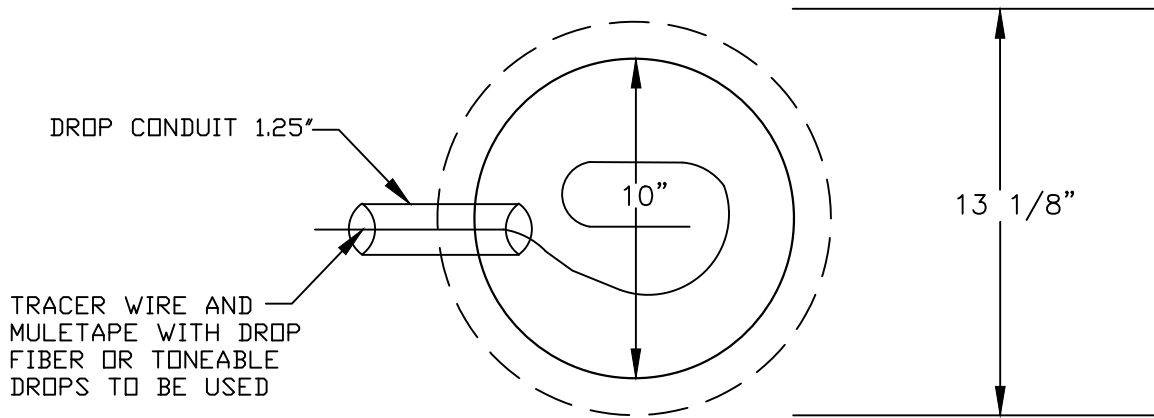

FLOWER POT

30"x48" PC UNIT, 2PC TIER 15/22
 18", 24", and 36" HEIGHT



AMERICAN POLYMER COMPANY

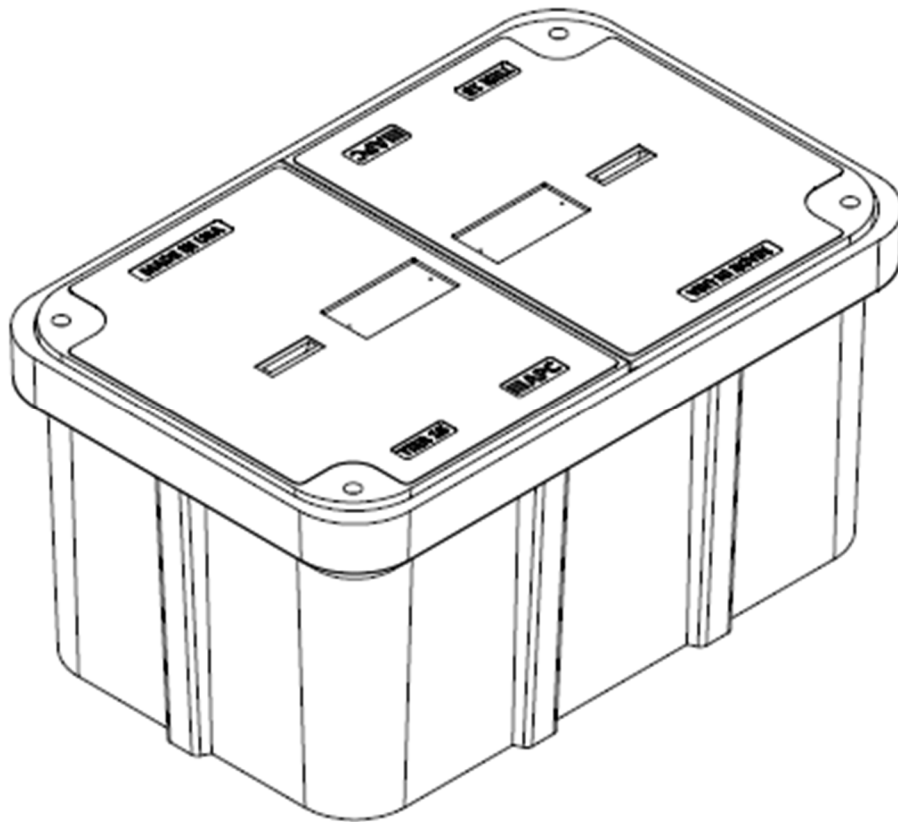

Description	Nominal Size	ANSI Tier	Part Number	Estimated Weight
PC Unit – TIER 15	30"x48"x18"	Tier 15	P304818HU15...	460 lbs.
PC Unit – TIER 22	30"x48"x18"	Tier 22	P304818HU22...	525 lbs.
PC Unit – TIER 15	30"x48"x24"	Tier 15	P304824HU15...	510 lbs.
PC Unit – TIER 22	30"x48"x24"	Tier 22	P304824HU22...	575 lbs.
PC Unit – TIER 15	30"x48"x36"	Tier 15	P304836HU15...	615 lbs.
PC Unit – TIER 22	30"x48"x36"	Tier 22	P304836HU22...	680 lbs.



30"x48" PC UNIT, 2PC TIER 15/22

18", 24", and 36" HEIGHT



AMERICAN POLYMER COMPANY

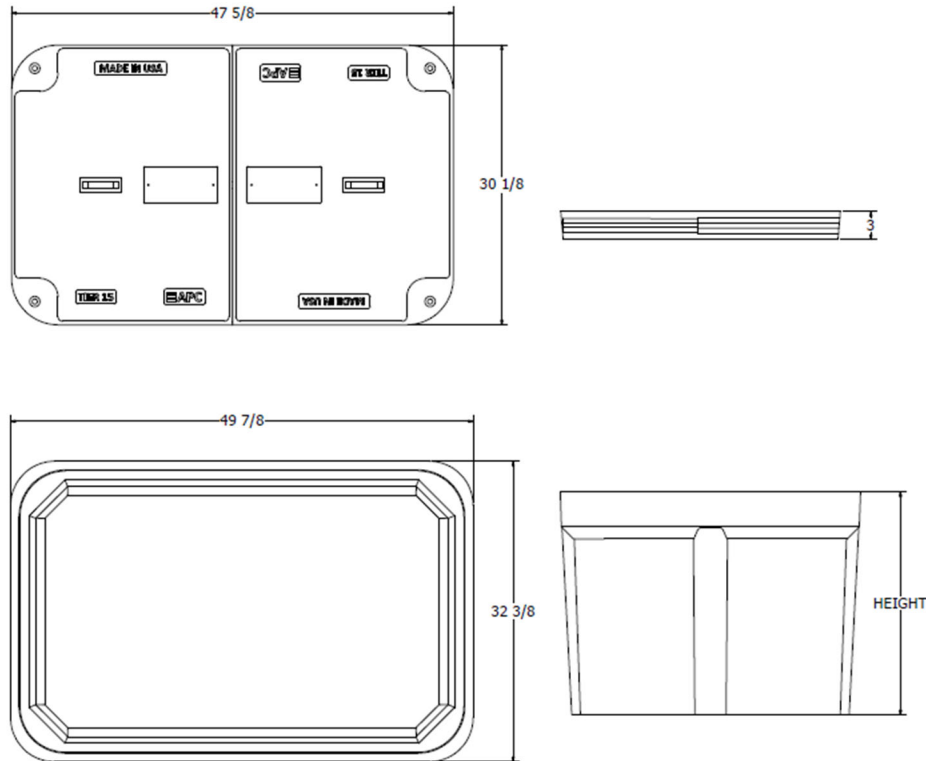

Components	Nominal Size	ANSI Tier	Part Number	Estimated Weight
Replacement Box	30"x48"x18"	Tier 22	P304818B22	185 lbs.
Replacement Box	30"x48"x24"	Tier 22	P304824B22	235 lbs.
Replacement Box	30"x48"x36"	Tier 22	P304836B22	340 lbs.
Replacement Lids - T15	30"x48" (half)	Tier 15	Various	150 lbs.
Replacement Lids - T22	30"x48" (half)	Tier 22	Various	170 lbs.

Bolt options



Machine Thread



Auger Thread



24"x36" PC UNIT, TIER 15/22
 18", 24", 30", and 36" HEIGHT



AMERICAN POLYMER COMPANY

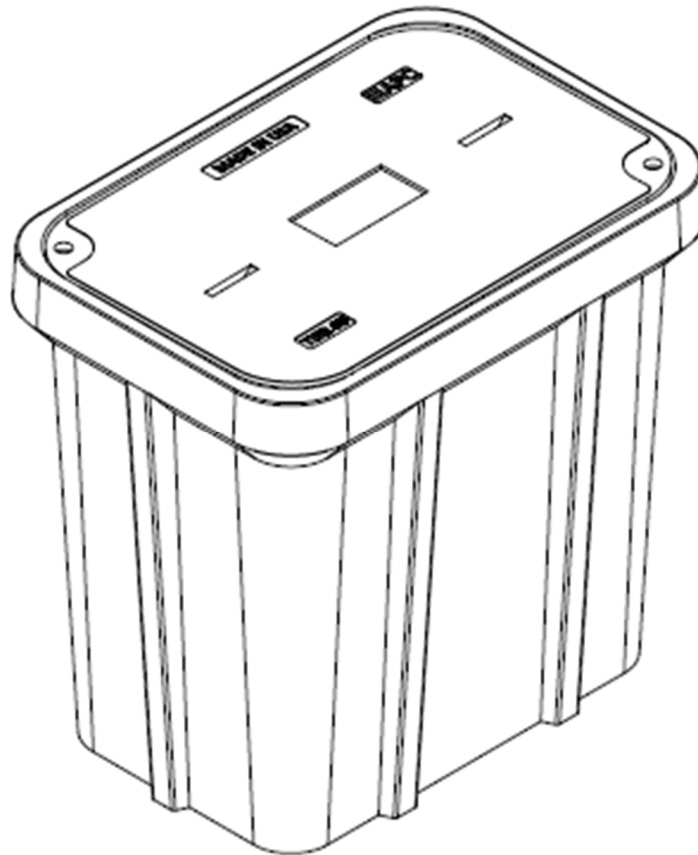

Description	Nominal Size	ANSI Tier	Part Number	Estimated Weight
PC Unit – TIER 15	24x36"x18"	Tier 15	P243618U15...	335 lbs.
PC Unit – TIER 22	24x36"x18"	Tier 22	P243618U22...	355 lbs.
PC Unit – TIER 15	24x36"x24"	Tier 15	P243624U15...	365 lbs.
PC Unit – TIER 22	24x36"x24"	Tier 22	P243624U22...	385 lbs.
PC Unit – TIER 15	24x36"x30"	Tier 15	P243630U15...	395 lbs.
PC Unit – TIER 22	24x36"x30"	Tier 22	P243630U22...	415 lbs.
PC Unit – TIER 15	24x36"x36"	Tier 15	P243636U15...	425 lbs.
PC Unit – TIER 22	24x36"x36"	Tier 22	P243636U22...	445 lbs.



24"x36" PC UNIT, TIER 15/22

18", 24", 30", and 36" HEIGHT



AMERICAN POLYMER COMPANY

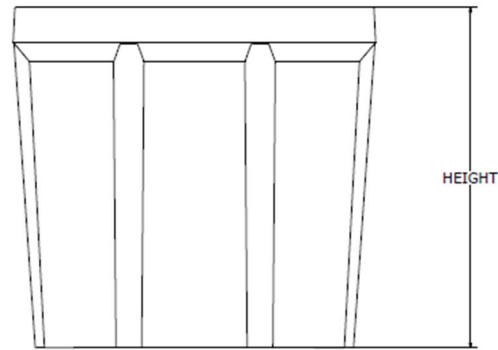
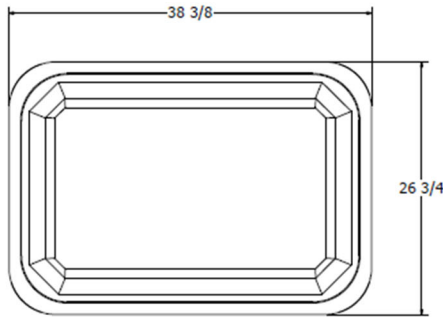
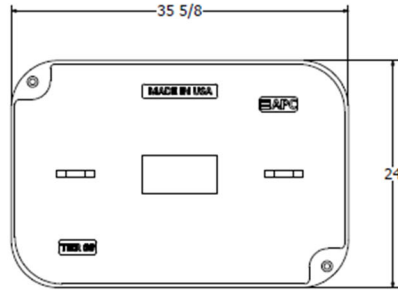

Components	Nominal Size	ANSI Tier	Part Number	Estimated Weight
Replacement Box	24"x36"x18"	Tier 22	P243618B22	165 lbs.
Replacement Box	24"x36"x24"	Tier 22	P243624B22	195 lbs.
Replacement Box	24"x36"x30"	Tier 22	P243630B22	225 lbs.
Replacement Box	24"x36"x36"	Tier 22	P243636B22	255 lbs.
Replacement Lids - T15	24"x36"	Tier 15	Various	170 lbs.
Replacement Lids - T22	24"x36"	Tier 22	Various	190 lbs.

Bolt options

Hex Head



Machine Thread



Penta Head



Auger Thread



17"x30" PC UNIT, TIER 15/22

12", 18", 24", and 30" HEIGHT



AMERICAN POLYMER COMPANY

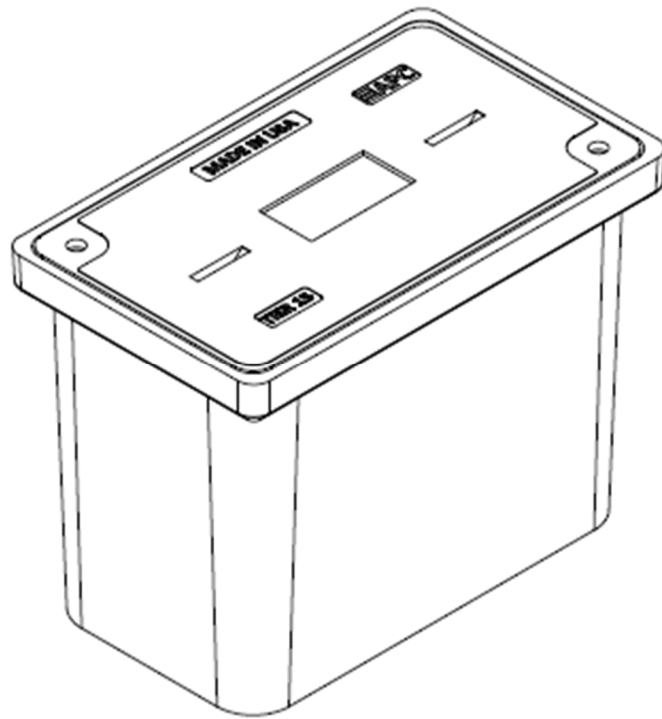

Description	Nominal Size	ANSI Tier	Part Number	Estimated Weight
PC Unit – TIER 15	17"x30"x12"	Tier 15	P173012U15...	138 lbs.
PC Unit – TIER 22	17"x30"x12"	Tier 22	P173012U22...	147 lbs.
PC Unit – TIER 15	17"x30"x18"	Tier 15	P173018U15...	172 lbs.
PC Unit – TIER 22	17"x30"x18"	Tier 22	P173018U22...	181 lbs.
PC Unit – TIER 15	17"x30"x24"	Tier 15	P173024U15...	192 lbs.
PC Unit – TIER 22	17"x30"x24"	Tier 22	P173024U22...	201 lbs.
PC Unit – TIER 15	17"x30"x30"	Tier 15	P173030U15...	217 lbs.
PC Unit – TIER 22	17"x30"x30"	Tier 22	P173030U22...	226 lbs.



17"x30" PC UNIT, TIER 15/22

12", 18", 24", and 30" HEIGHT



AMERICAN POLYMER COMPANY

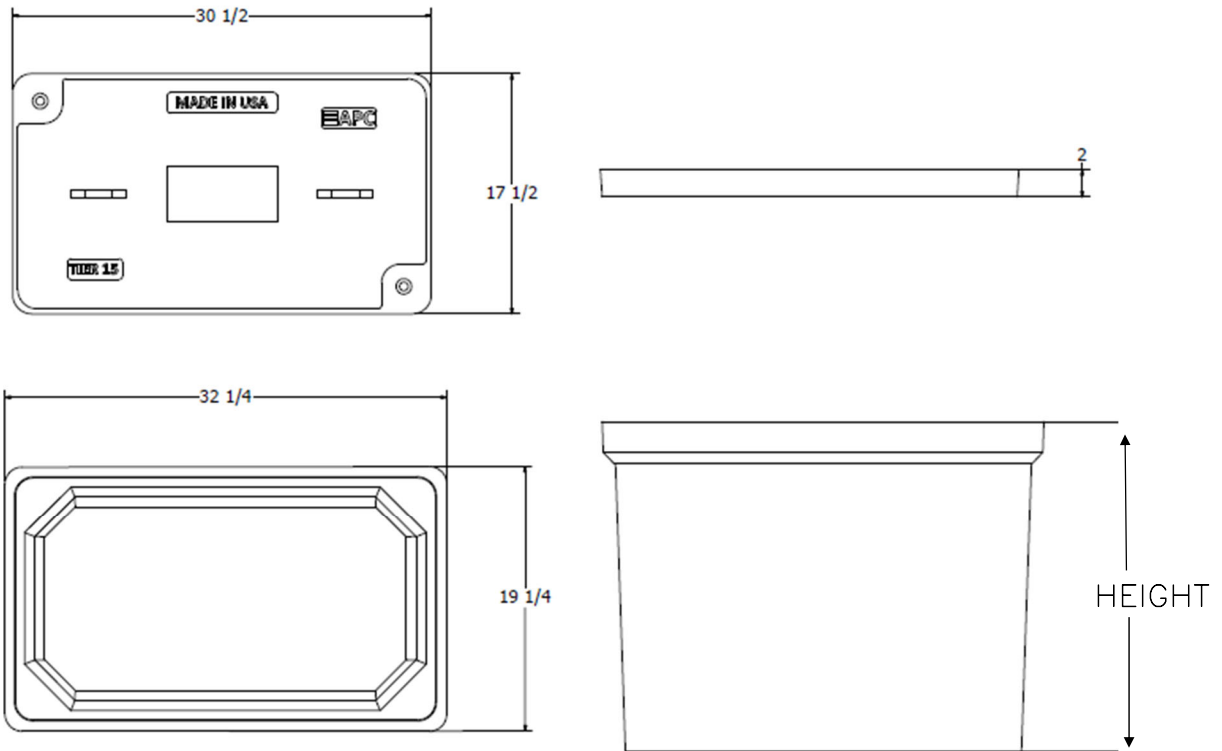

Components	Nominal Size	ANSI Tier	Part Number	Estimated Weight
Replacement Box	17"x30"x12"	Tier 22	P173012B22	66 lbs.
Replacement Box	17"x30"x18"	Tier 22	P173018B22	100 lbs.
Replacement Box	17"x30"x24"	Tier 22	P173024B22	120 lbs.
Replacement Box	17"x30"x30"	Tier 22	P173030B22	145 lbs.
Replacement Lids – T15	17"x30"	Tier 15	Various	72 lbs.
Replacement Lids – T22	17"x30"	Tier 22	Various	81 lbs.

Bolt options



Machine Thread



Auger Thread



33"x60" PC UNIT, 2PC TIER 15/22
36" HEIGHT



AMERICAN POLYMER COMPANY

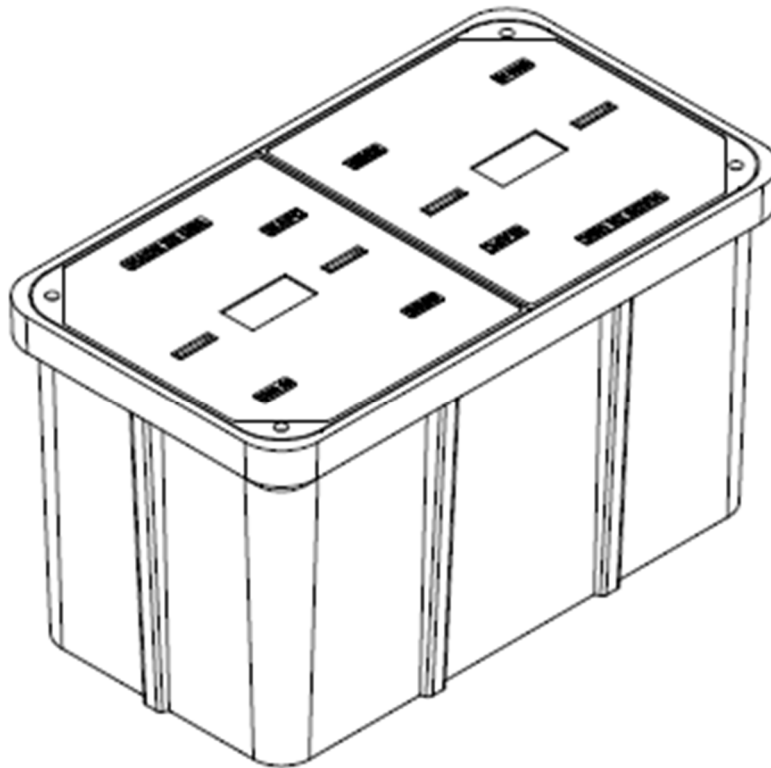

Description	Nominal Size	ANSI Tier	Part Number	Estimated Weight
PC Unit - TIER 15	33"x60"x36"	Tier 15	P336036U15...	930 lbs.
PC Unit - TIER 22	33"x60"x36"	Tier 22	P336036U22...	1030 lbs.



33"x60" PC UNIT, 2PC TIER 15/22

36" HEIGHT



AMERICAN POLYMER COMPANY

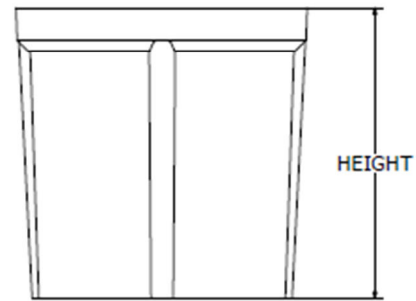
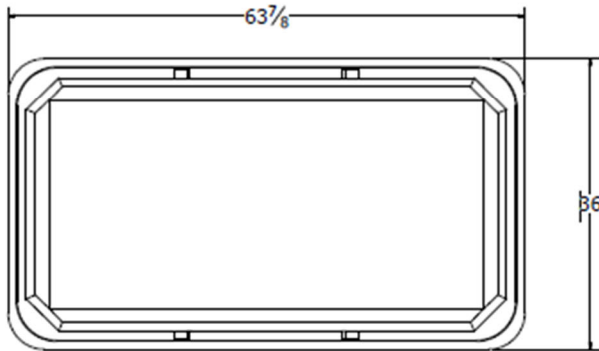
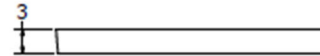

Components	Nominal Size	ANSI Tier	Part Number	Estimated Weight
Replacement Box	33"x60"x36"	Tier 22	P336036B22	530 lbs.
Replacement Lids - T15	33"x60" (half)	Tier 15	Various	200 lbs.
Replacement Lids - T22	33"x60" (half)	Tier 22	Various	250 lbs.

Bolt options

Hex Head



Machine Thread



Penta Head



Auger Thread



Speed (MPH) Prior To Road Work	SIGN SPACING, FT.		Must be Approved by an Engineer				
	Non-Divided Highways	Divided Highways	BUFFER SPACE, FT.	TAPER LENGTH, FT.	CHANNELIZING SPACING, FT.		
	Length	Shoulder (10 ft. Width)	Lane (12 ft. Width)	Through Taper	Through Buffer/Work Area		
0-35	200	200	250	70	245	35	50
40-45	350	500	360	150	540	40	80
50-55	500	1000	495	185	660	50	100
60-70	SA-1000, SB-1500, SC-2640		730	235	840	60	120
Urban Low Speed - 100 FT							

APPROVED/ACCEPTED BY:
ENGINEER, OWNER, or PRIME CONTRACTOR
 Check for Notice to Proceed.

Signature: _____

Company: _____

Date: 11/27/2023 **Project:** BLN01b-F09_N Lincoln St TCP ;
Traffic Control Suggestion For: ATLANTIC ENGINEERING (AEG) ;
By: Road Runner Safety Services, Inc. : Nathan

Comments:
 Drawing not to scale. Traffic control plan must be approved by an engineer. This is a suggestion only. Road Runners Safety Services, Inc. has no liability for this suggested traffic control plan. Actual placement and spacing of all traffic control devices will depend on field conditions and must conform to MUTCD standards.



Spacing Charts Based on MUTCD		Must be Approved by an Engineer					
Speed (MPH) Prior To Road Work	SIGN SPACING, FT.		BUFFER SPACE, FT.	TAPER LENGTH, FT.		CHANNELIZING SPACING, FT.	
	Non-Divided Highways	Divided Highways	Length	Shoulder (10 ft Width)	Lane (12 ft Width)	Through Taper	Through Buffer/Work Area
0-35	200	200	250	70	245	35	50
40-45	350	500	360	150	540	40	80
50-55	500	1000	495	185	660	50	100
60-70	SA-1000, SB-1500, SC-2640		730	235	840	60	120
Urban Low Speed - 100 FT							

APPROVED/ACCEPTED BY:
ENGINEER, OWNER, or PRIME CONTRACTOR
 Check for Notice to Proceed.
BLN01b-F09_N Lincoln St TCP2

Signature: _____
Company: _____



Date: 11/27/2023 Project: BLN01b-F09_N Lincoln St TCP2 :
: **Traffic Control Suggestion For:** AEG :
By: Road Runner Safety Services, Inc. : Nathan

Comments:
Drawing not to scale. Traffic control plan must be approved by an engineer. This is a suggestion only. Road Runners Safety Services, Inc. has no liability for this suggested traffic control plan. Actual placement and spacing of all traffic control devices will depend on field conditions and must conform to MUTCD standards.

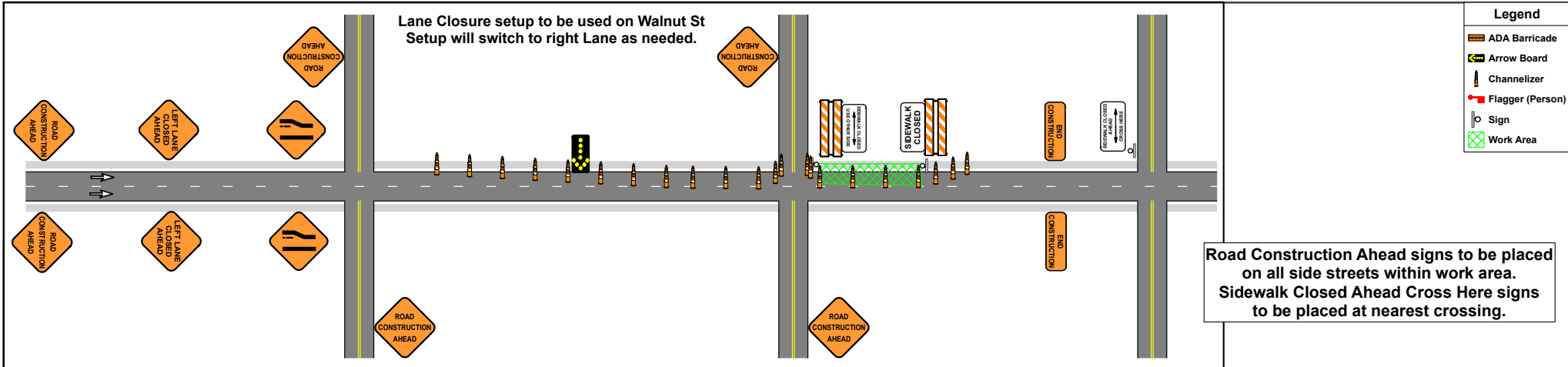

- Legend**
- ADA Barricade
 - Arrow Board
 - Channelizer
 - Flagger (Person)
 - Sign
 - Work Area

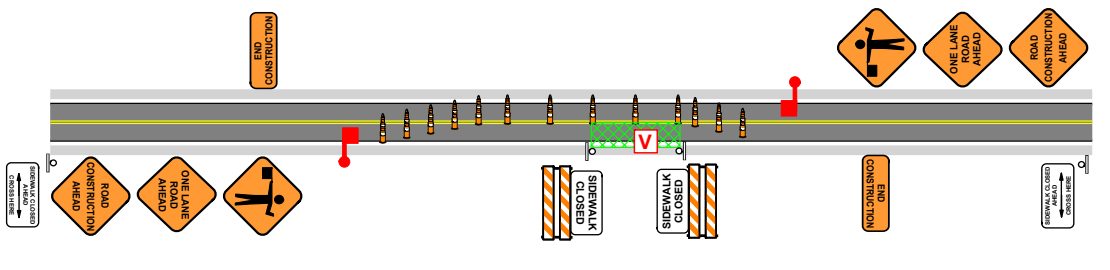
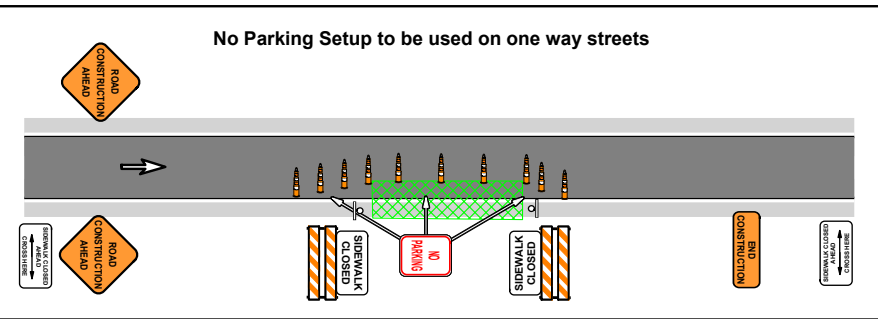
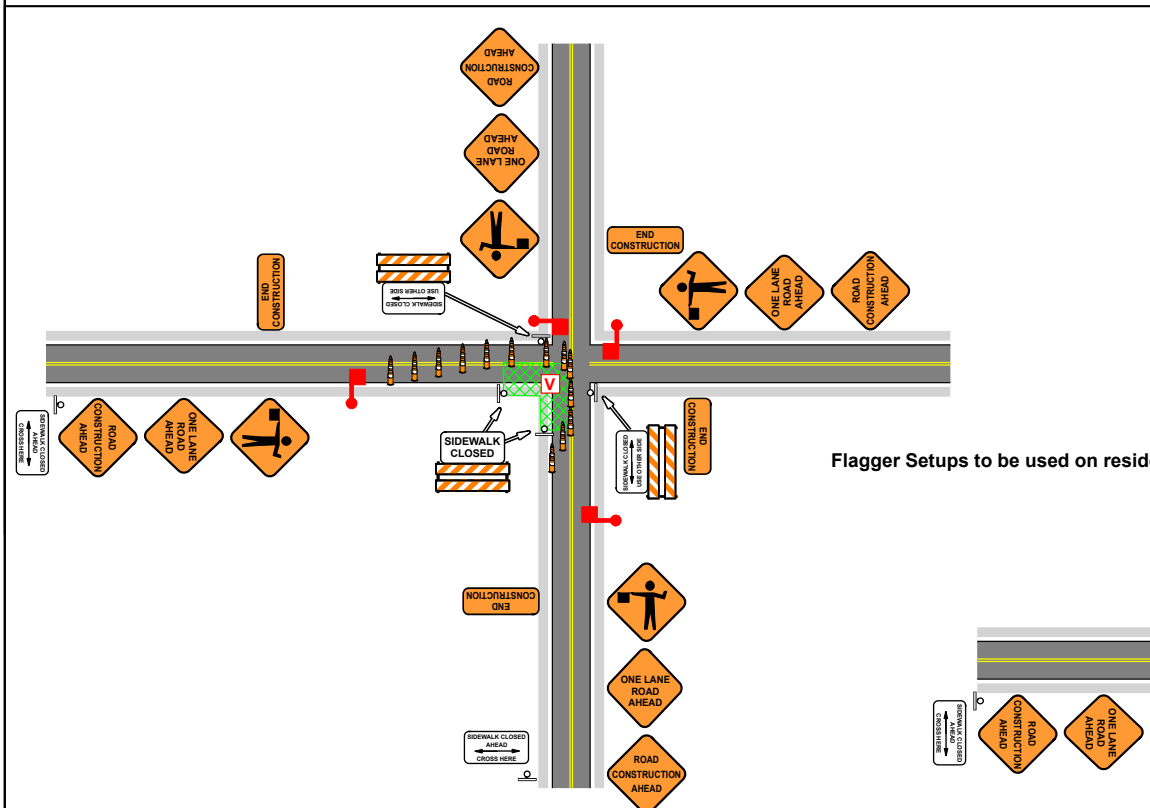

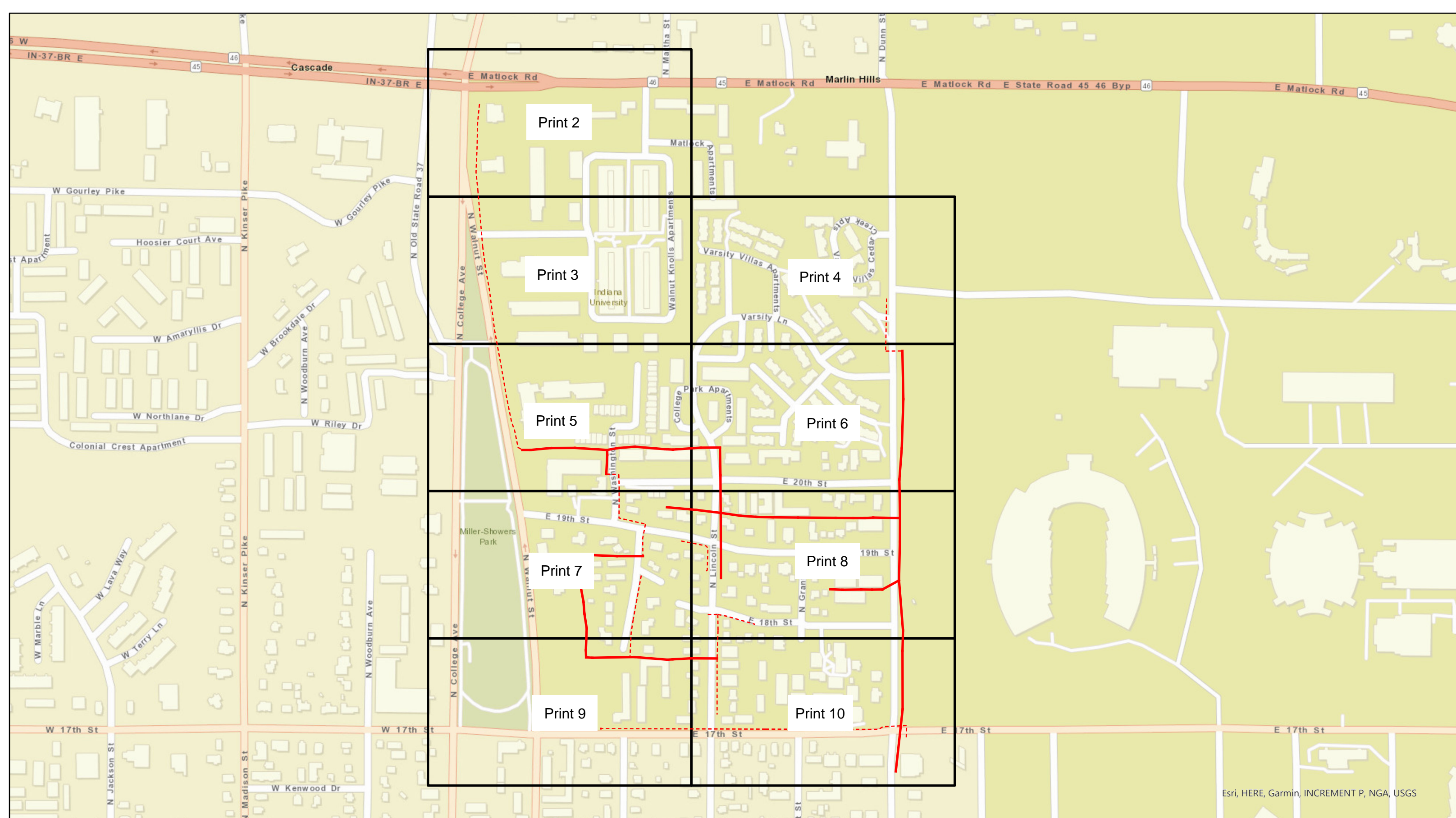

Esri, HERE, Garmin, INCREMENT P, NGA, USGS



Legend BLN01a-F02_E 19th St

- Proposed Strand
- - - Proposed Conduit
- Grids

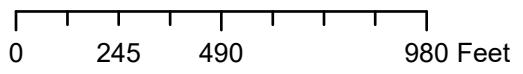

City of Bloomington, IN Permit:
Design View

INI	BY	DATE	DESCRIPTION



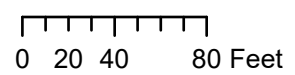
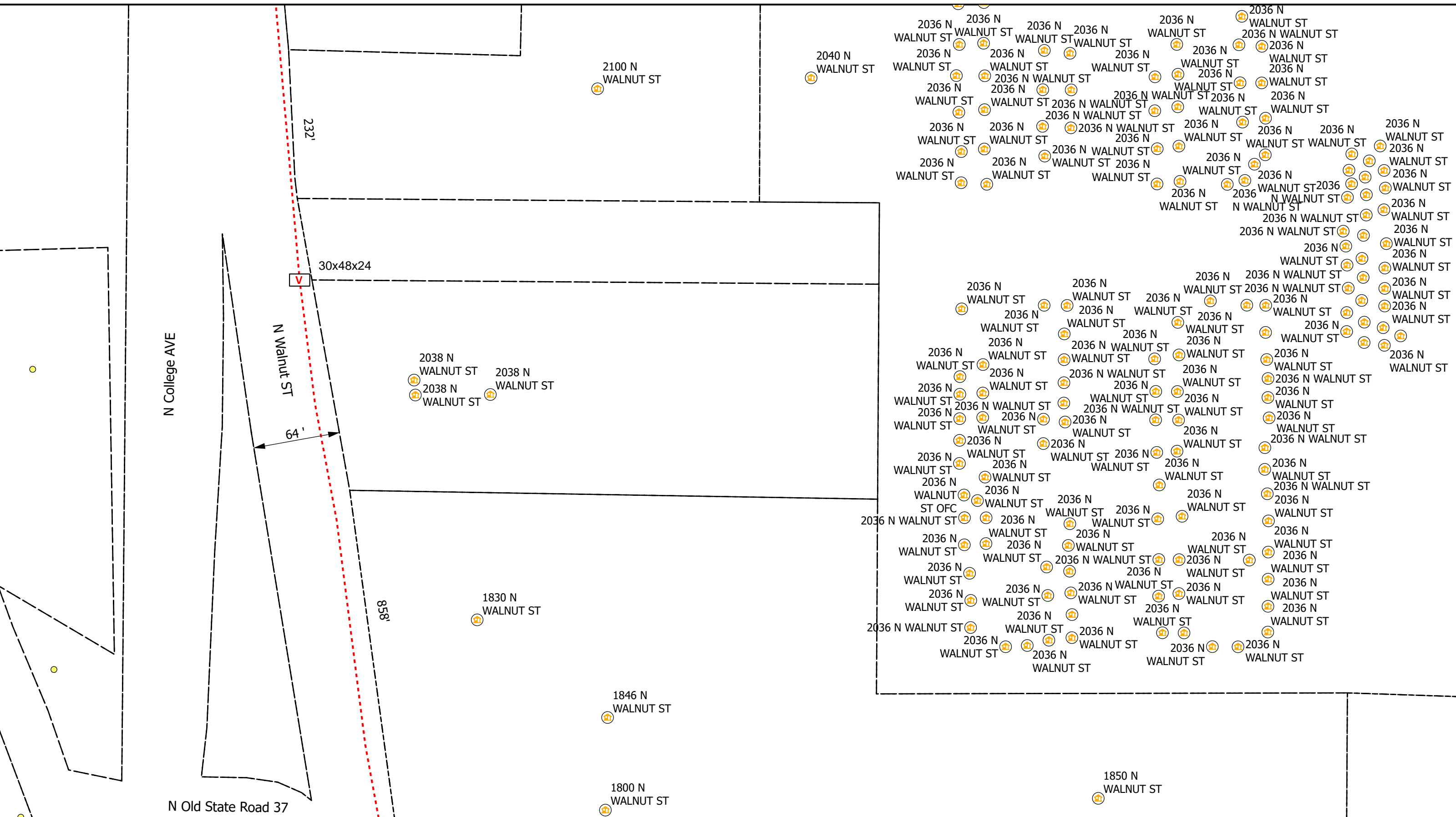

Legend

- Poles
- V Vaults
- Overhead Strand
- Conduit
- R Risers
- A Address
- Y Anchor
- └ Sidewalk
- Bloomington_Parcels
- Grids

All Flowerpots 12" DIA



City of Bloomington, IN Permit:
Design View

INI	BY	DATE	DESCRIPTION



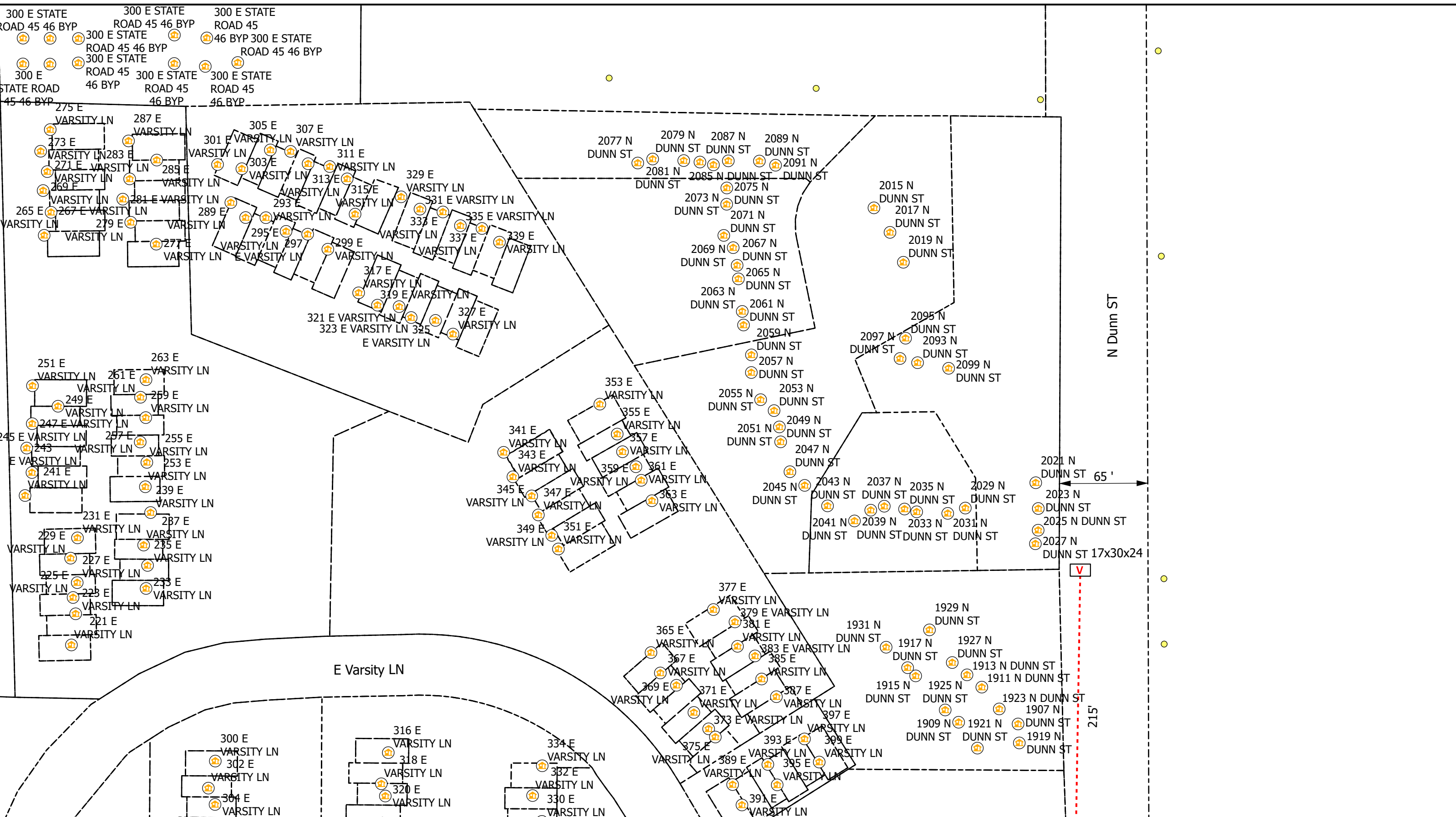

0 20 40 80 Feet

Legend

- Poles
- Risers
- ↖ Sidewalk
- V Vaults
- Overhead Strand
- Conduit
- Y Anchor
- Bloomington_Parcels
- Grids

All Flowerpots 12" DIA



City of Bloomington, IN Permit:
Design View

INI	BY	DATE	DESCRIPTION



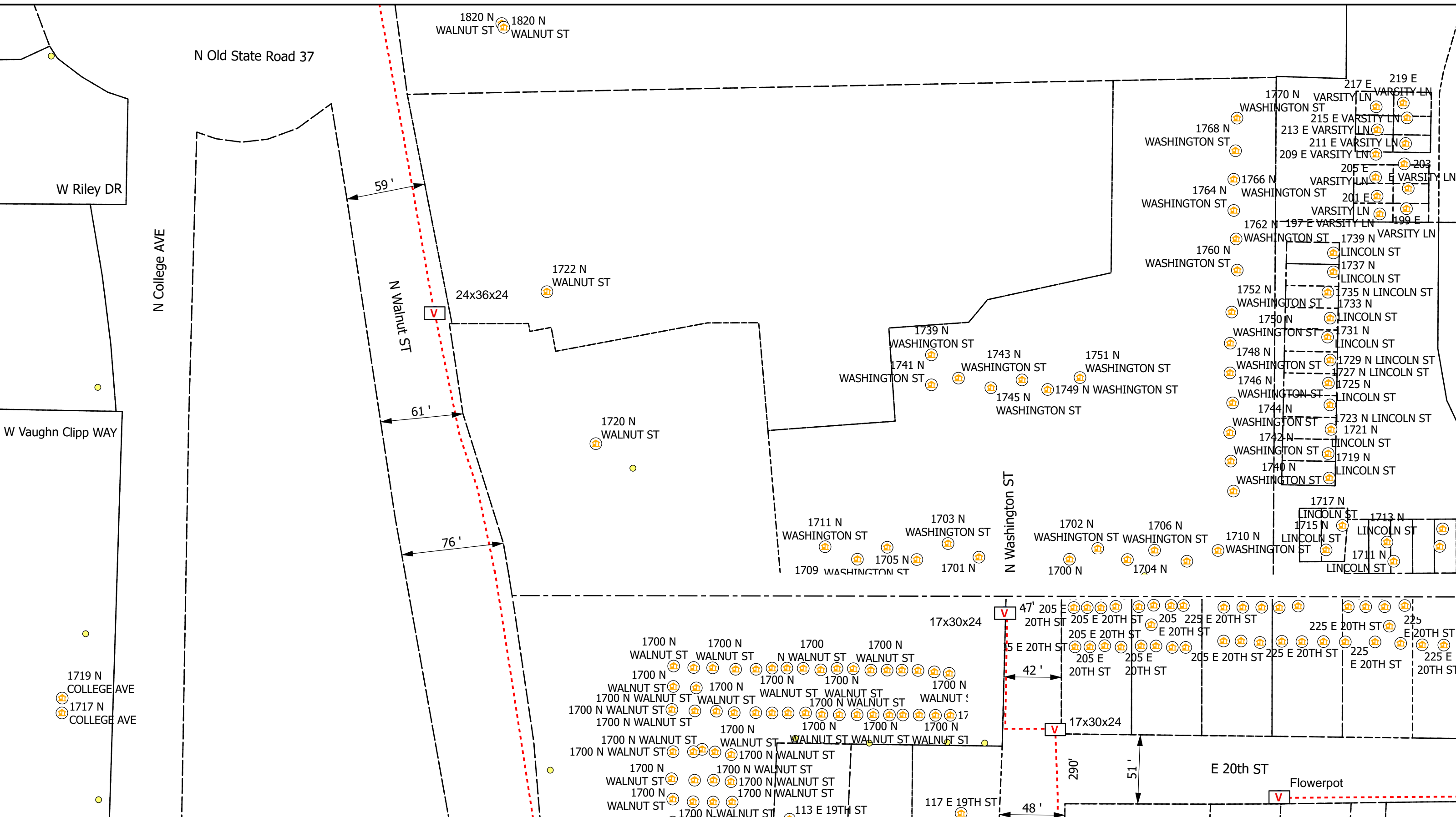

Legend

- Poles
- Vaults
- Overhead Strand
- Conduit
- Risers
- Address
- Anchor
- Sidewalk
- Bloomington_Parcels
- Grids

All Flowerpots 12" DIA

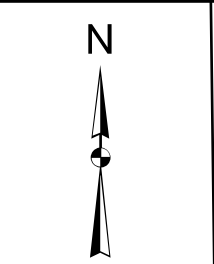

City of Bloomington, IN Permit:
Design View

INI	BY	DATE	DESCRIPTION

Print 5 of 10

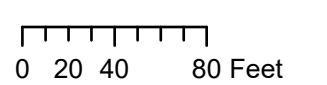
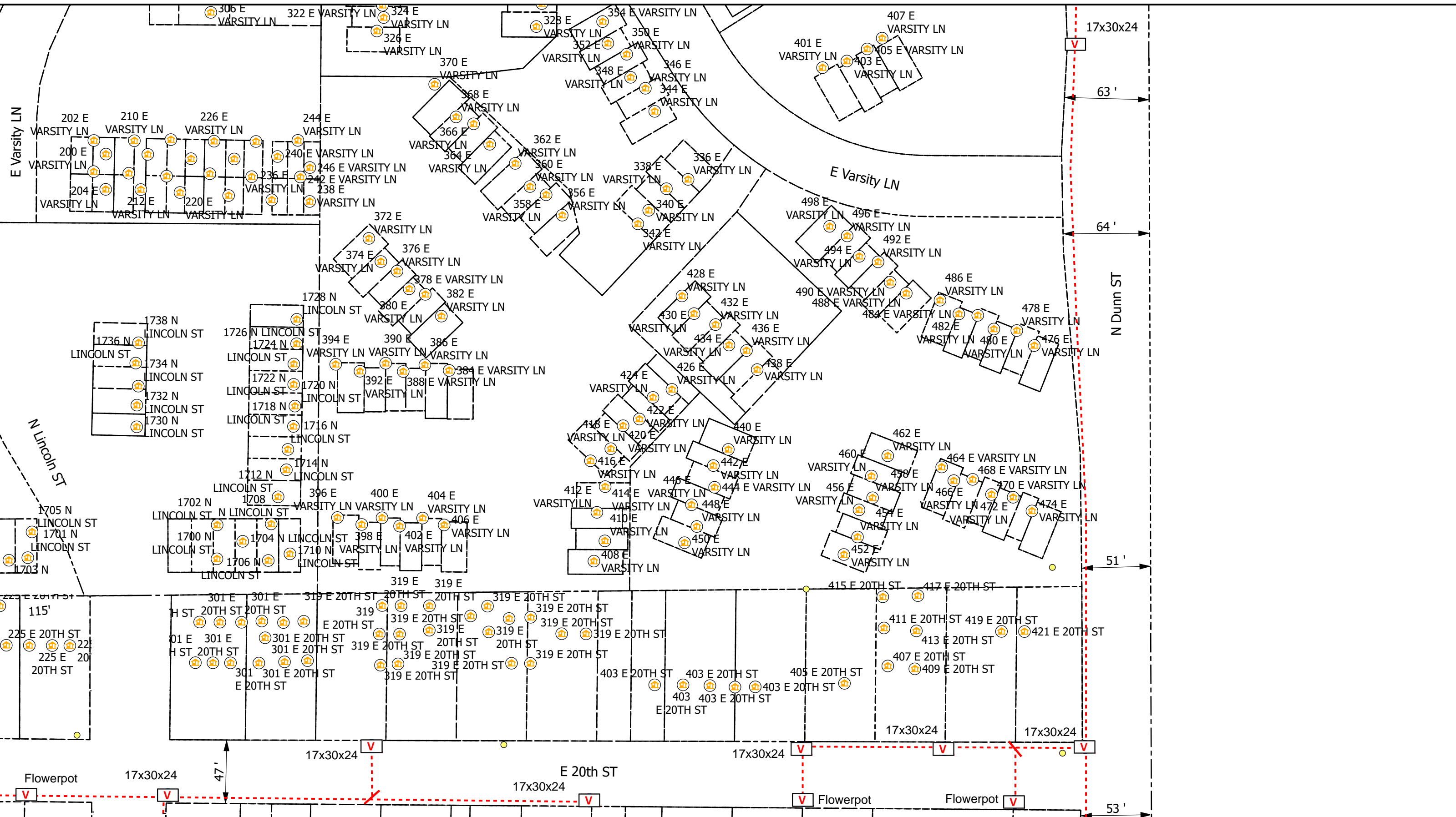

Legend

- Poles
- Ⓡ Risers
- ⬆ Sidewalk
- V Vaults
- Overhead Strand
- Conduit
- 🏠 Address
- Y Anchor
- Bloomington_Parcels
- Grids

All Flowerpots 12" DIA



City of Bloomington, IN Permit:
Design View

INI	BY	DATE	DESCRIPTION



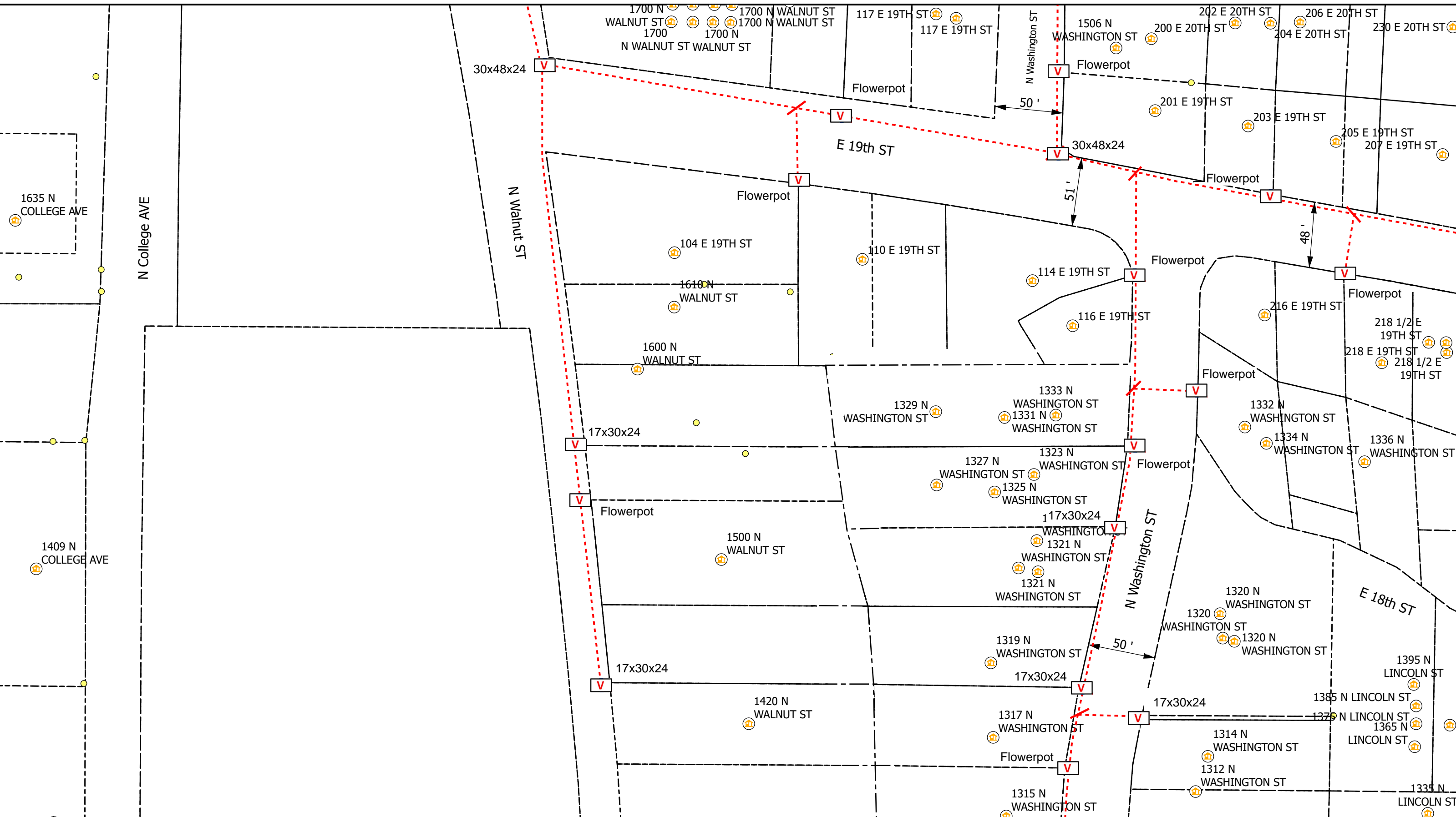

Legend

- Poles
- Ⓡ Risers
- Ⓜ Vaults
- 🏠 Address
- Overhead Strand
- ⚓ Anchor
- - - Conduit
- ↖ Sidewalk
- ⌚ Bloomington_Parcels
- ▭ Grids

All Flowerpots 12" DIA

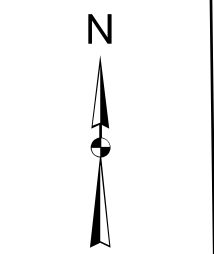

City of Bloomington, IN Permit:
Design View

INI	BY	DATE	DESCRIPTION

Indiana 811

Print 7 of 10

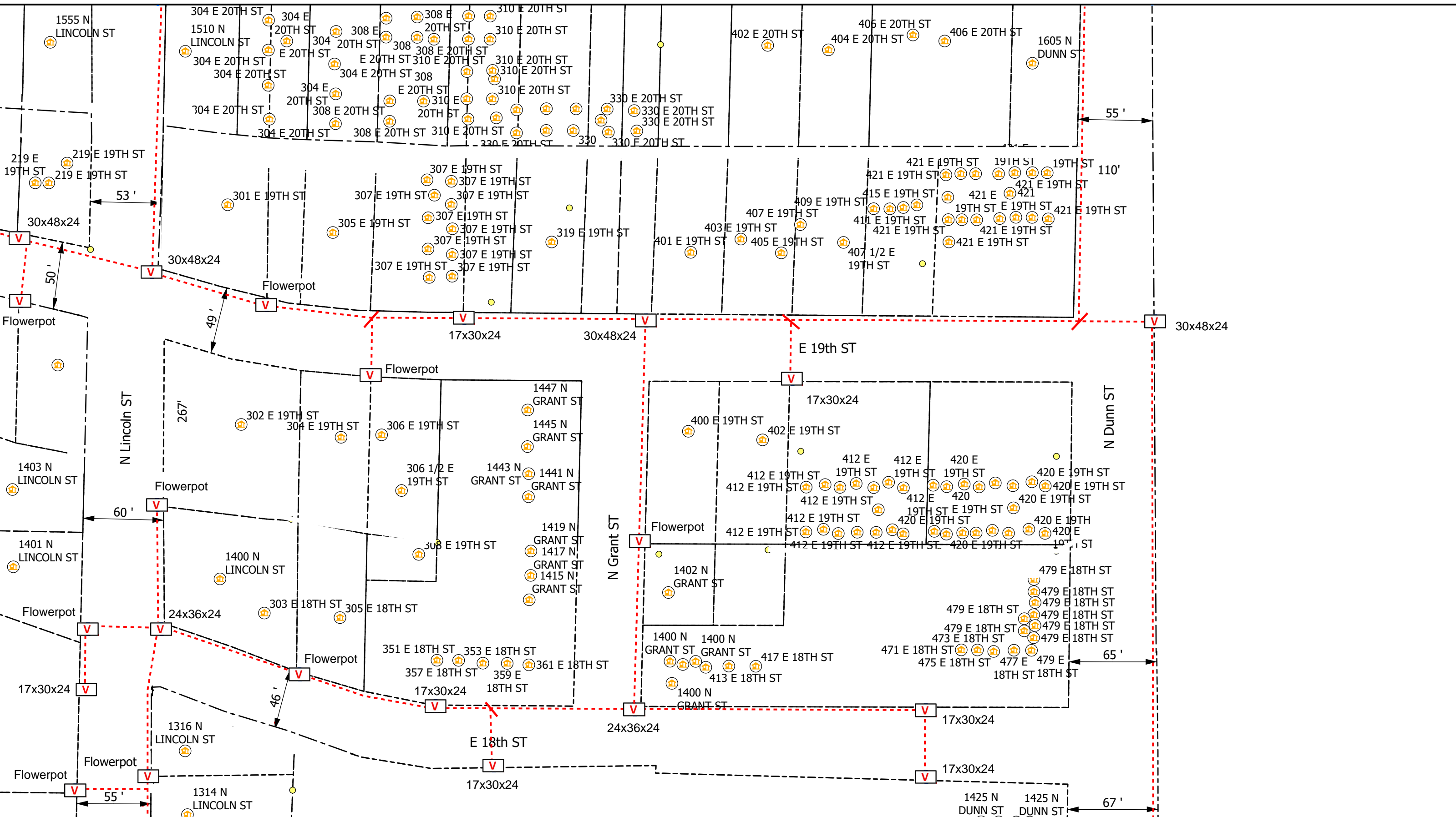

Legend

- Poles
- Ⓜ Risers
- Ⓜ Sidewalk
- V Vaults
- 🏠 Address
- Bloomington_Parcels
- Overhead Strand
- Conduit
- Y Anchor
- Grids

All Flowerpots 12" DIA



City of Bloomington, IN Permit:
Design View

INI	BY	DATE	DESCRIPTION



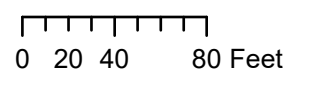
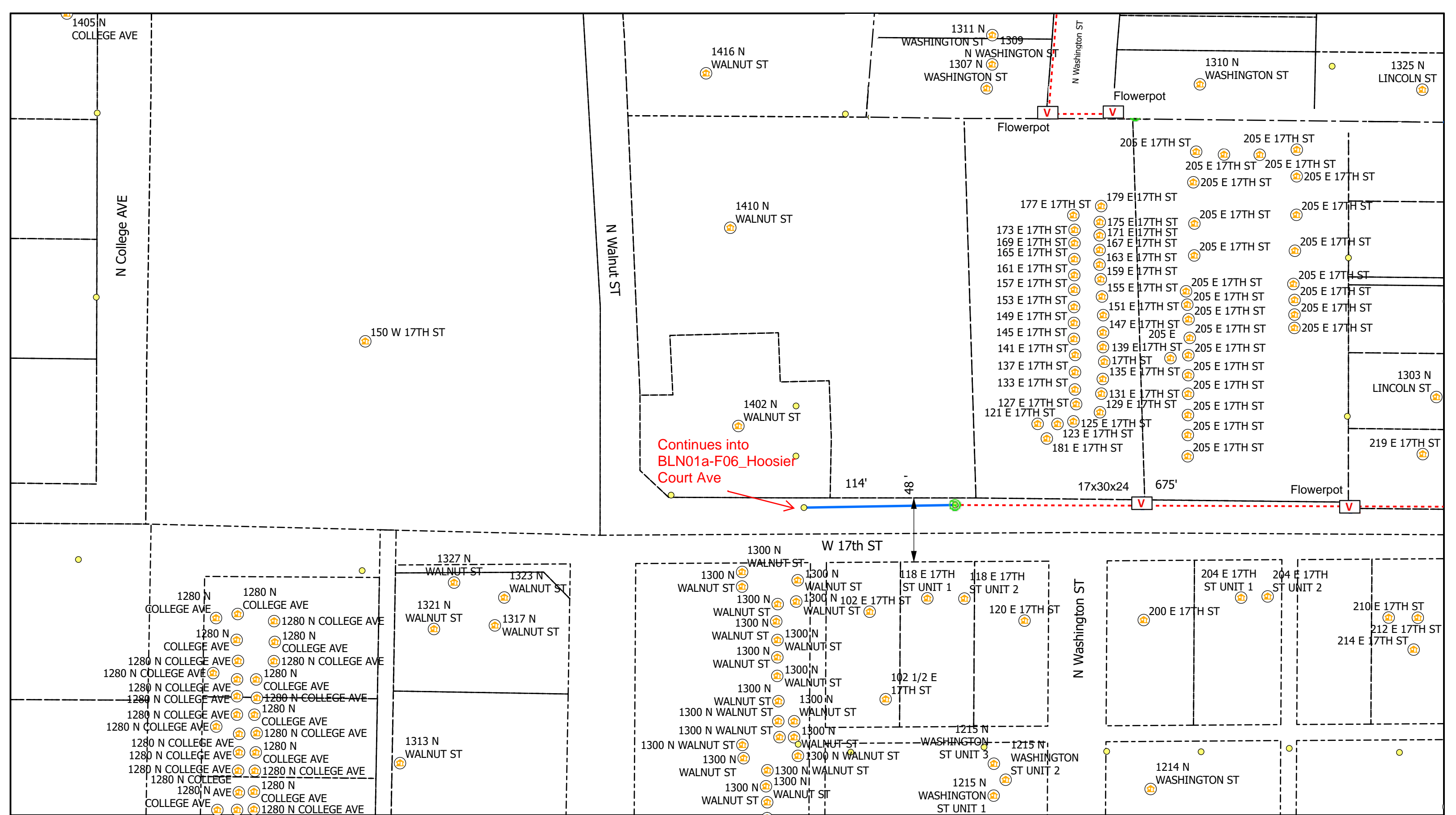

Legend

- Poles
- V Vaults
- Overhead Strand
- Conduit
- R Risers
- Ⓜ Address
- Y Anchor
- ↖ Sidewalk
- Bloomington_Parcels
- Grids

All Flowerpots 12" DIA



City of Bloomington, IN Permit:
Design View

INI	BY	DATE	DESCRIPTION



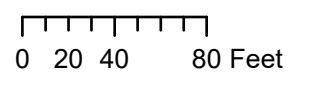
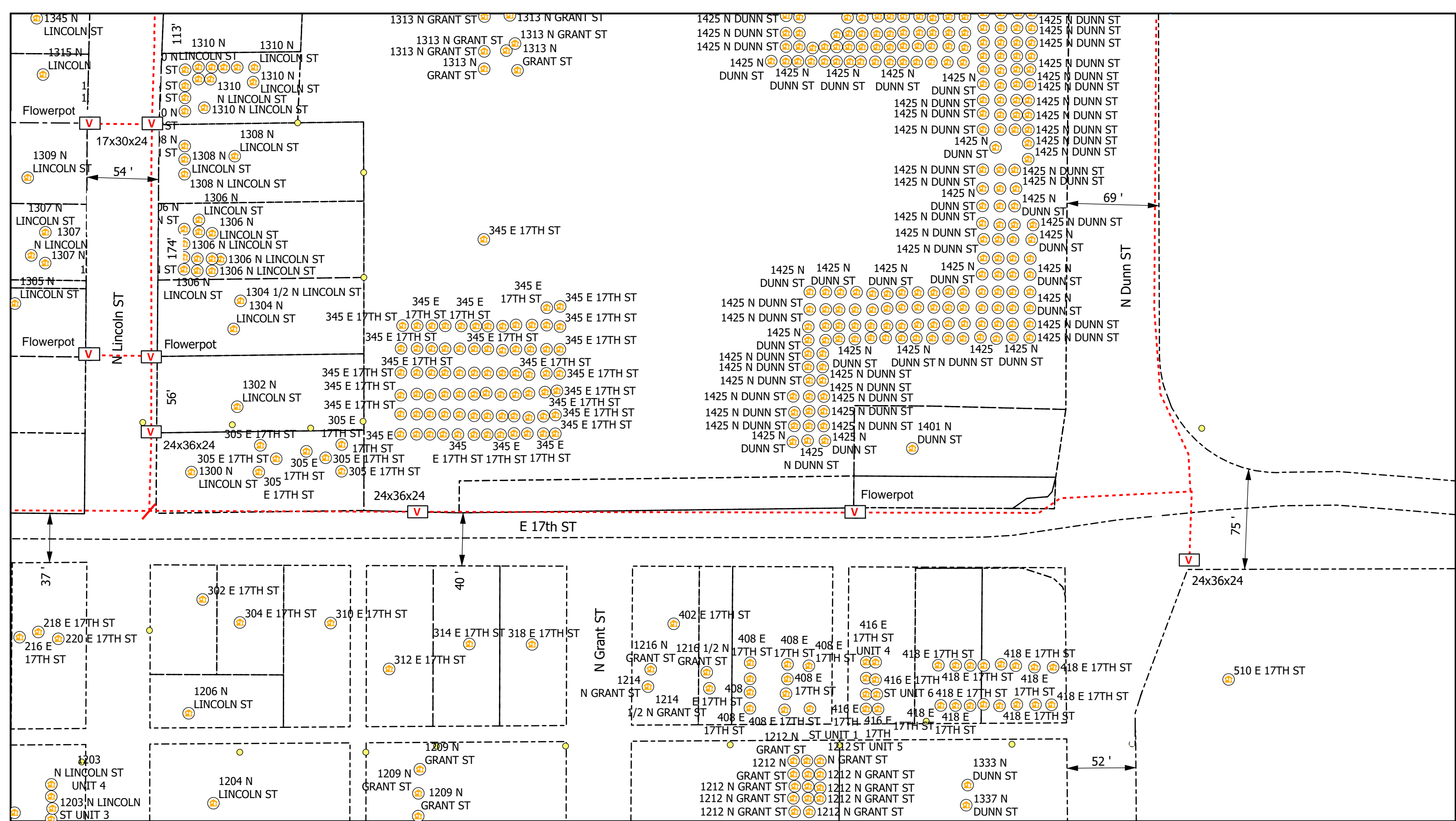

Legend

- Poles
- ⓧ Vaults
- Overhead Strand
- - - Conduit
- Ⓜ Risers
- Ⓜ Address
- Y Anchor
- ↖ Sidewalk
- Bloomington_Parcels
- Grids

All Flowerpots 12" DIA



City of Bloomington, IN Permit:
Design View

INI	BY	DATE	DESCRIPTION



CONCEPTUAL SIDE VIEW

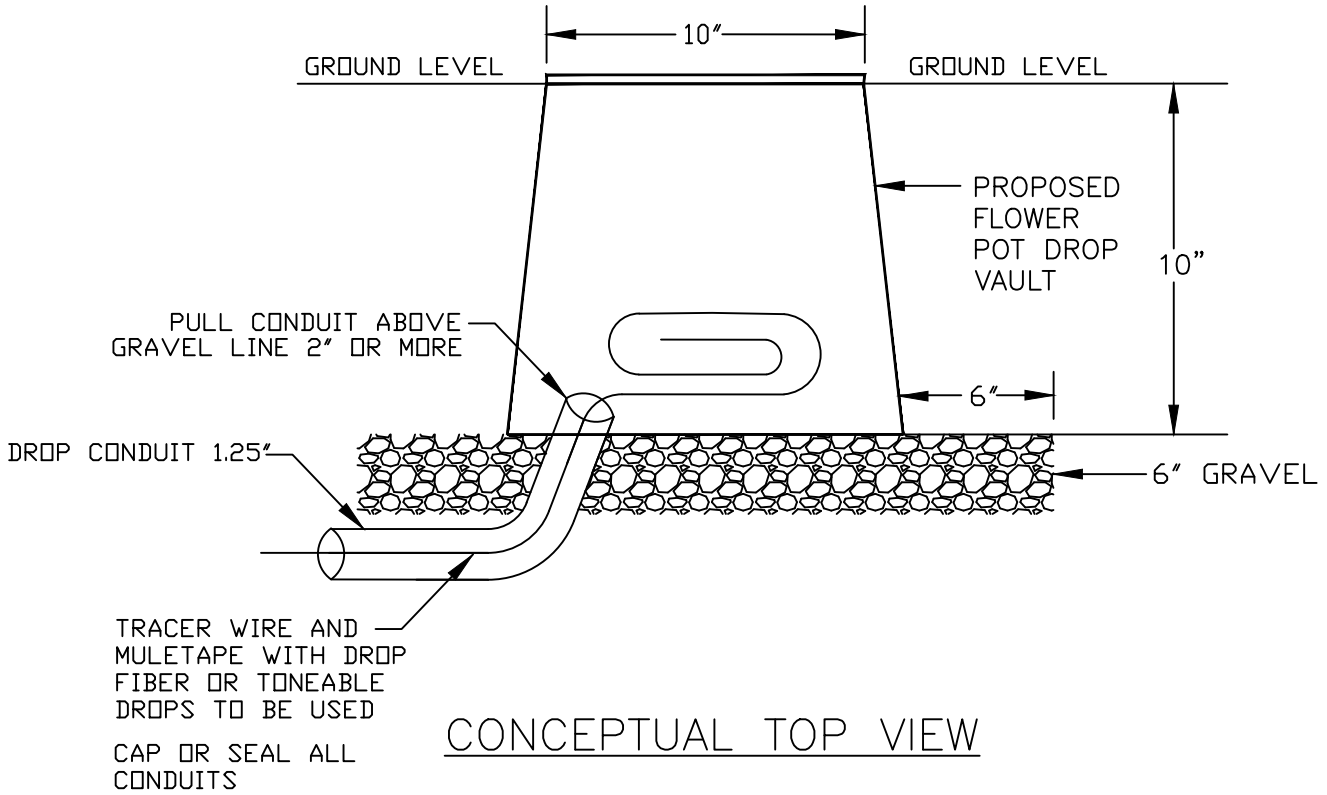

CONCEPTUAL TOP VIEW

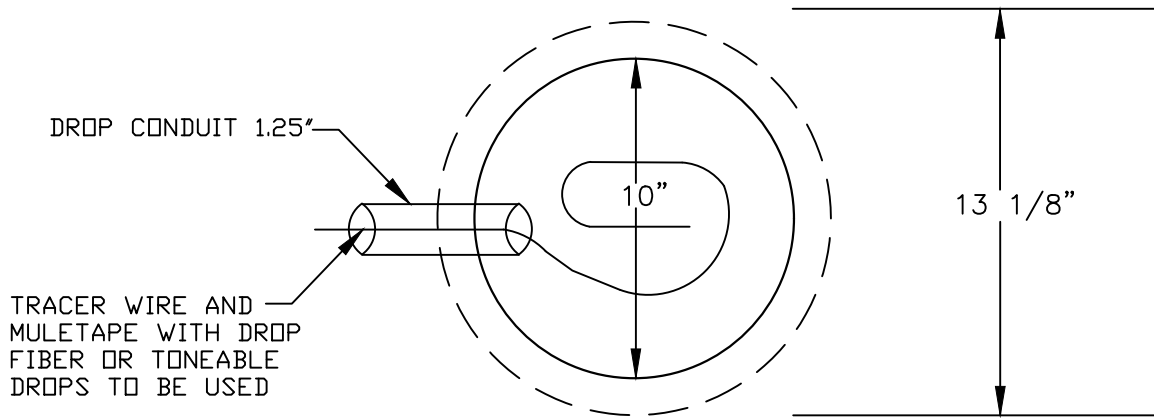

FLOWER POT

30"x48" PC UNIT, 2PC TIER 15/22
 18", 24", and 36" HEIGHT



AMERICAN POLYMER COMPANY

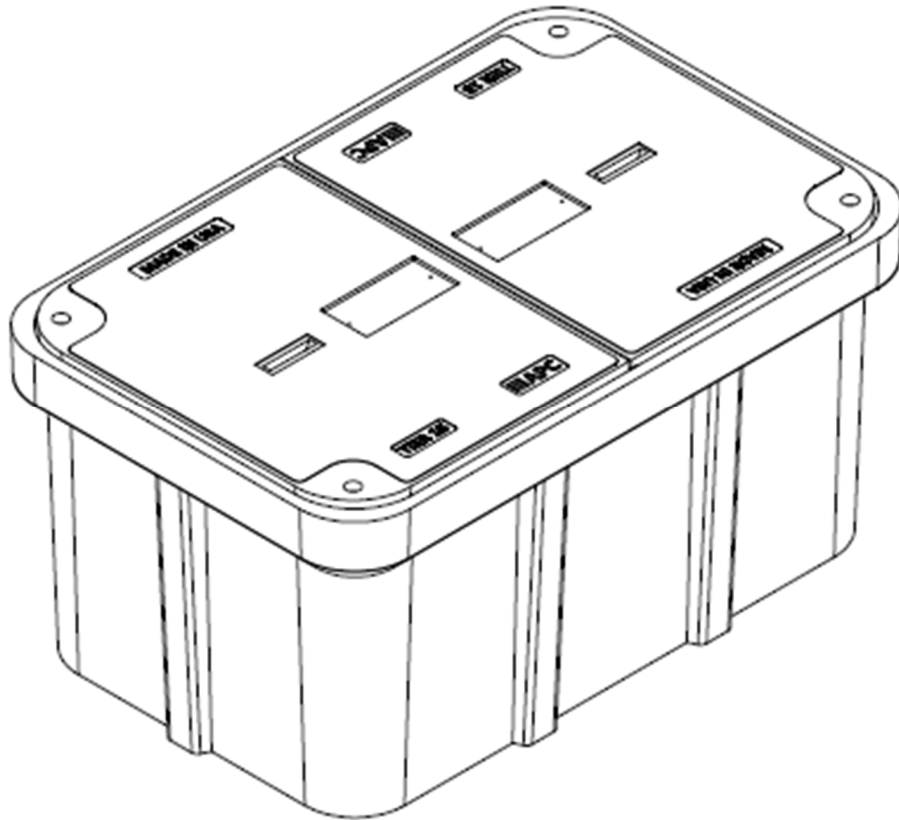

Description	Nominal Size	ANSI Tier	Part Number	Estimated Weight
PC Unit – TIER 15	30"x48"x18"	Tier 15	P304818HU15...	460 lbs.
PC Unit – TIER 22	30"x48"x18"	Tier 22	P304818HU22...	525 lbs.
PC Unit – TIER 15	30"x48"x24"	Tier 15	P304824HU15...	510 lbs.
PC Unit – TIER 22	30"x48"x24"	Tier 22	P304824HU22...	575 lbs.
PC Unit – TIER 15	30"x48"x36"	Tier 15	P304836HU15...	615 lbs.
PC Unit – TIER 22	30"x48"x36"	Tier 22	P304836HU22...	680 lbs.



30"x48" PC UNIT, 2PC TIER 15/22

18", 24", and 36" HEIGHT



AMERICAN POLYMER COMPANY

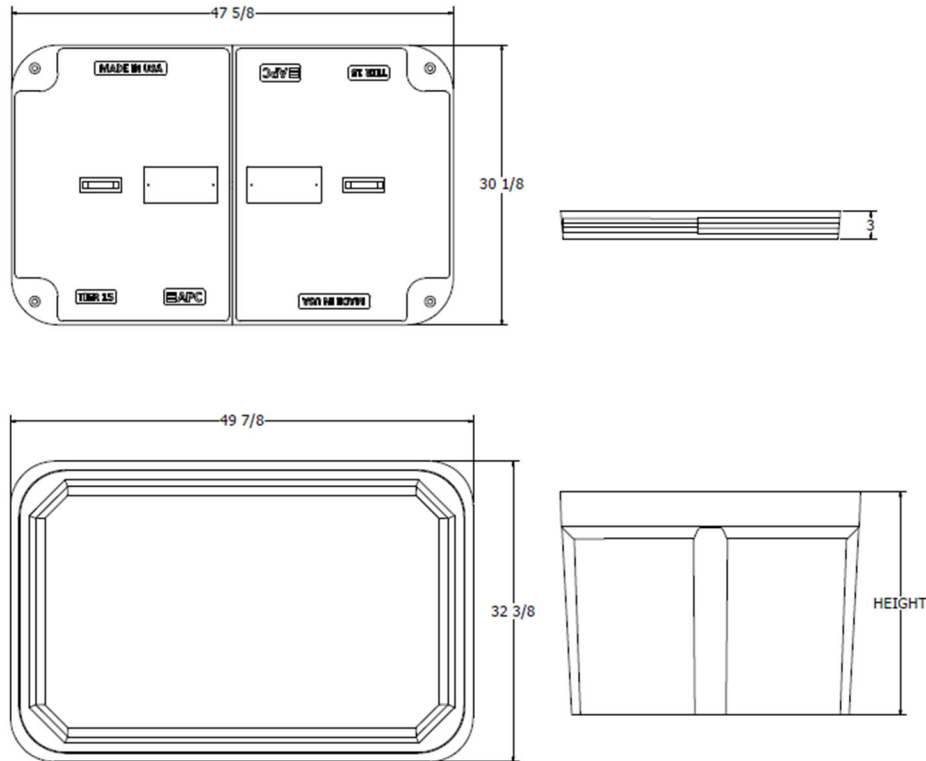

Components	Nominal Size	ANSI Tier	Part Number	Estimated Weight
Replacement Box	30"x48"x18"	Tier 22	P304818B22	185 lbs.
Replacement Box	30"x48"x24"	Tier 22	P304824B22	235 lbs.
Replacement Box	30"x48"x36"	Tier 22	P304836B22	340 lbs.
Replacement Lids - T15	30"x48" (half)	Tier 15	Various	150 lbs.
Replacement Lids - T22	30"x48" (half)	Tier 22	Various	170 lbs.

Bolt options



Machine Thread



Auger Thread



24"x36" PC UNIT, TIER 15/22
 18", 24", 30", and 36" HEIGHT



AMERICAN POLYMER COMPANY

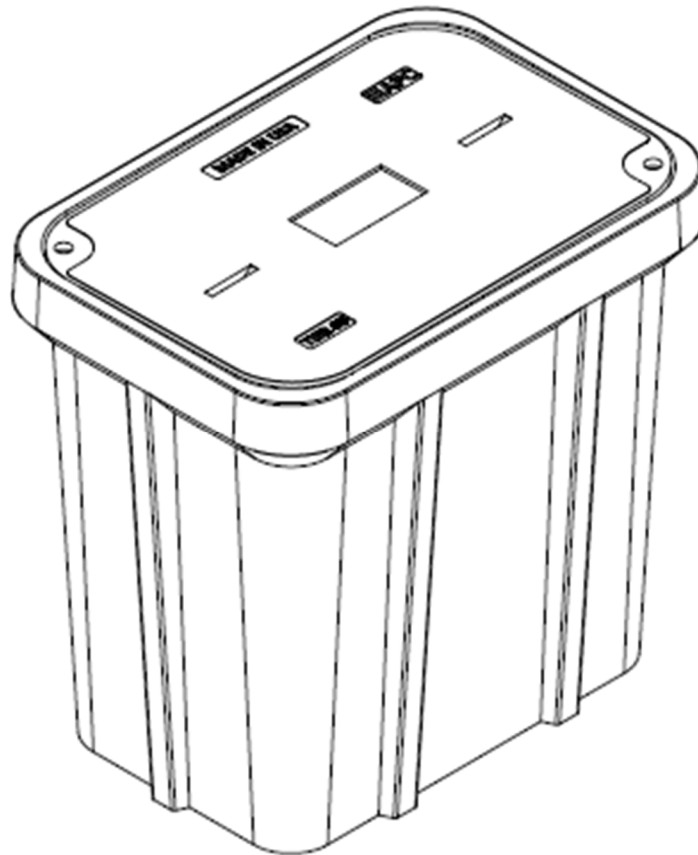

Description	Nominal Size	ANSI Tier	Part Number	Estimated Weight
PC Unit – TIER 15	24x36"x18"	Tier 15	P243618U15...	335 lbs.
PC Unit – TIER 22	24x36"x18"	Tier 22	P243618U22...	355 lbs.
PC Unit – TIER 15	24x36"x24"	Tier 15	P243624U15...	365 lbs.
PC Unit – TIER 22	24x36"x24"	Tier 22	P243624U22...	385 lbs.
PC Unit – TIER 15	24x36"x30"	Tier 15	P243630U15...	395 lbs.
PC Unit – TIER 22	24x36"x30"	Tier 22	P243630U22...	415 lbs.
PC Unit – TIER 15	24x36"x36"	Tier 15	P243636U15...	425 lbs.
PC Unit – TIER 22	24x36"x36"	Tier 22	P243636U22...	445 lbs.



24"x36" PC UNIT, TIER 15/22

18", 24", 30", and 36" HEIGHT



AMERICAN POLYMER COMPANY

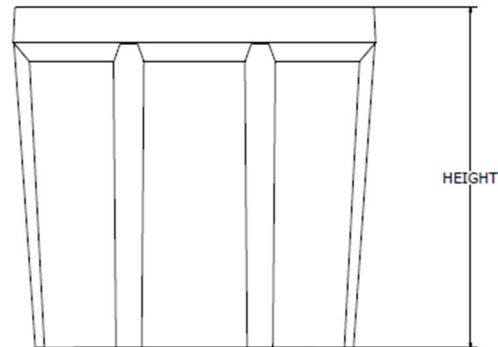
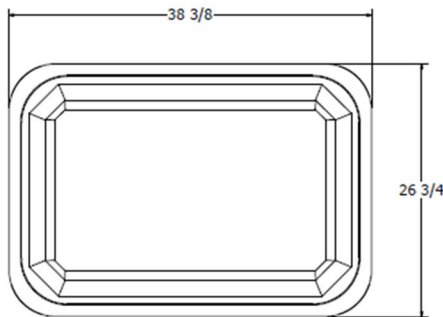
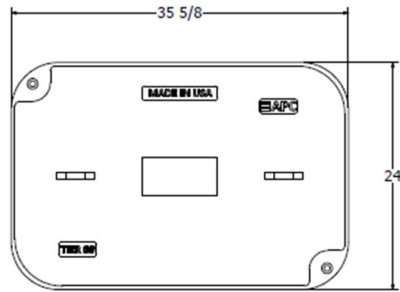

Components	Nominal Size	ANSI Tier	Part Number	Estimated Weight
Replacement Box	24"x36"x18"	Tier 22	P243618B22	165 lbs.
Replacement Box	24"x36"x24"	Tier 22	P243624B22	195 lbs.
Replacement Box	24"x36"x30"	Tier 22	P243630B22	225 lbs.
Replacement Box	24"x36"x36"	Tier 22	P243636B22	255 lbs.
Replacement Lids - T15	24"x36"	Tier 15	Various	170 lbs.
Replacement Lids - T22	24"x36"	Tier 22	Various	190 lbs.

Bolt options

Hex Head



Machine Thread



Penta Head



Auger Thread



17"x30" PC UNIT, TIER 15/22

12", 18", 24", and 30" HEIGHT



AMERICAN POLYMER COMPANY

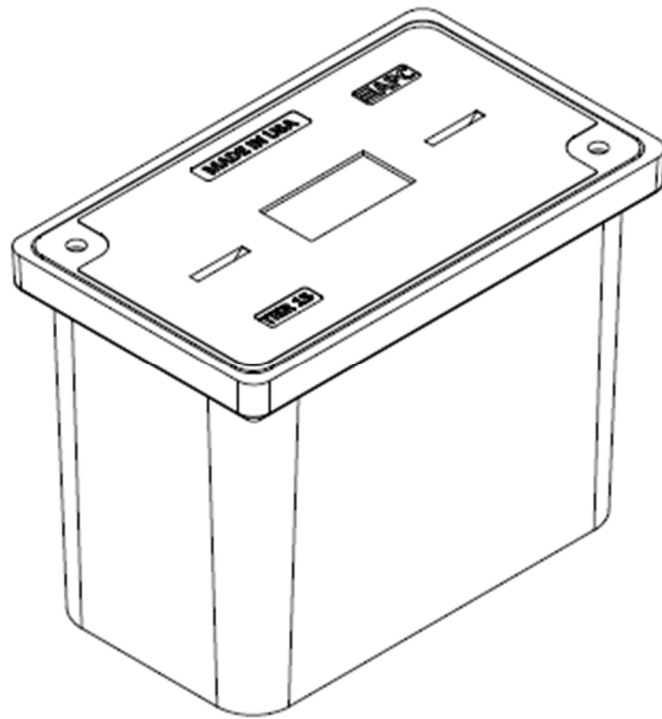

Description	Nominal Size	ANSI Tier	Part Number	Estimated Weight
PC Unit – TIER 15	17"x30"x12"	Tier 15	P173012U15...	138 lbs.
PC Unit – TIER 22	17"x30"x12"	Tier 22	P173012U22...	147 lbs.
PC Unit – TIER 15	17"x30"x18"	Tier 15	P173018U15...	172 lbs.
PC Unit – TIER 22	17"x30"x18"	Tier 22	P173018U22...	181 lbs.
PC Unit – TIER 15	17"x30"x24"	Tier 15	P173024U15...	192 lbs.
PC Unit – TIER 22	17"x30"x24"	Tier 22	P173024U22...	201 lbs.
PC Unit – TIER 15	17"x30"x30"	Tier 15	P173030U15...	217 lbs.
PC Unit – TIER 22	17"x30"x30"	Tier 22	P173030U22...	226 lbs.



17"x30" PC UNIT, TIER 15/22

12", 18", 24", and 30" HEIGHT



AMERICAN POLYMER COMPANY

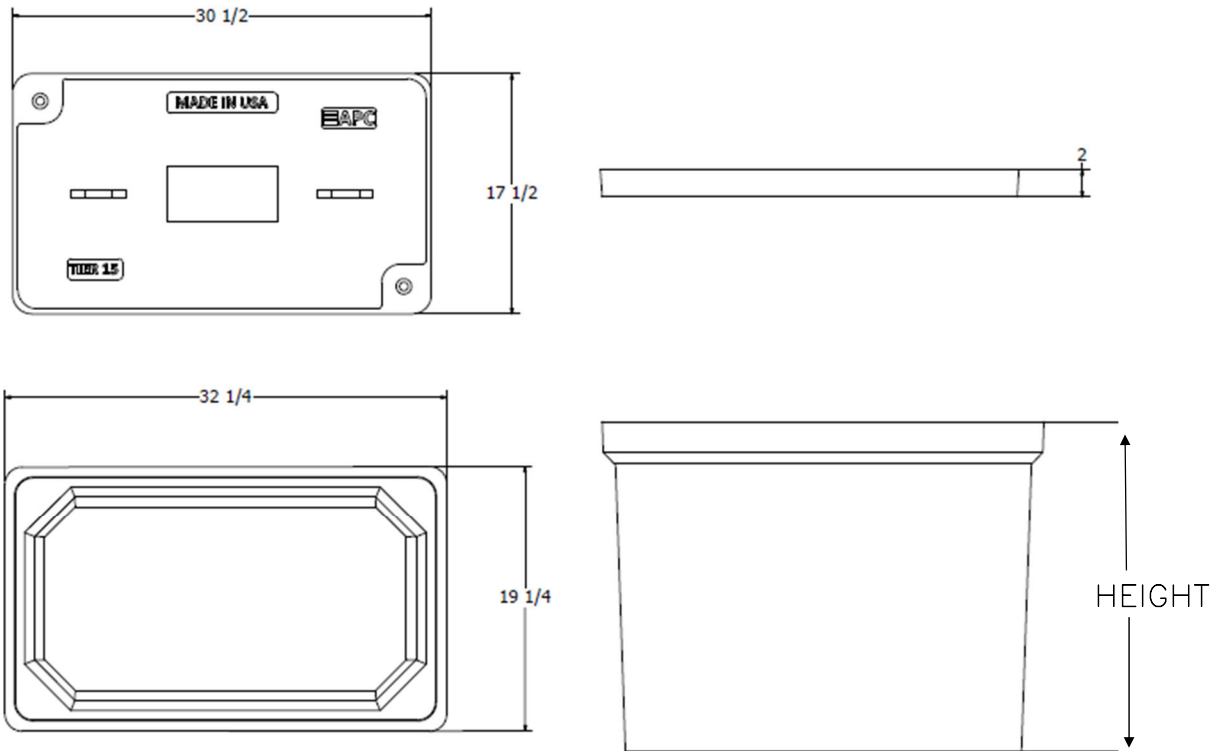

Components	Nominal Size	ANSI Tier	Part Number	Estimated Weight
Replacement Box	17"x30"x12"	Tier 22	P173012B22	66 lbs.
Replacement Box	17"x30"x18"	Tier 22	P173018B22	100 lbs.
Replacement Box	17"x30"x24"	Tier 22	P173024B22	120 lbs.
Replacement Box	17"x30"x30"	Tier 22	P173030B22	145 lbs.
Replacement Lids – T15	17"x30"	Tier 15	Various	72 lbs.
Replacement Lids – T22	17"x30"	Tier 22	Various	81 lbs.

Bolt options



Machine Thread



Auger Thread



33"x60" PC UNIT, 2PC TIER 15/22
36" HEIGHT



AMERICAN POLYMER COMPANY

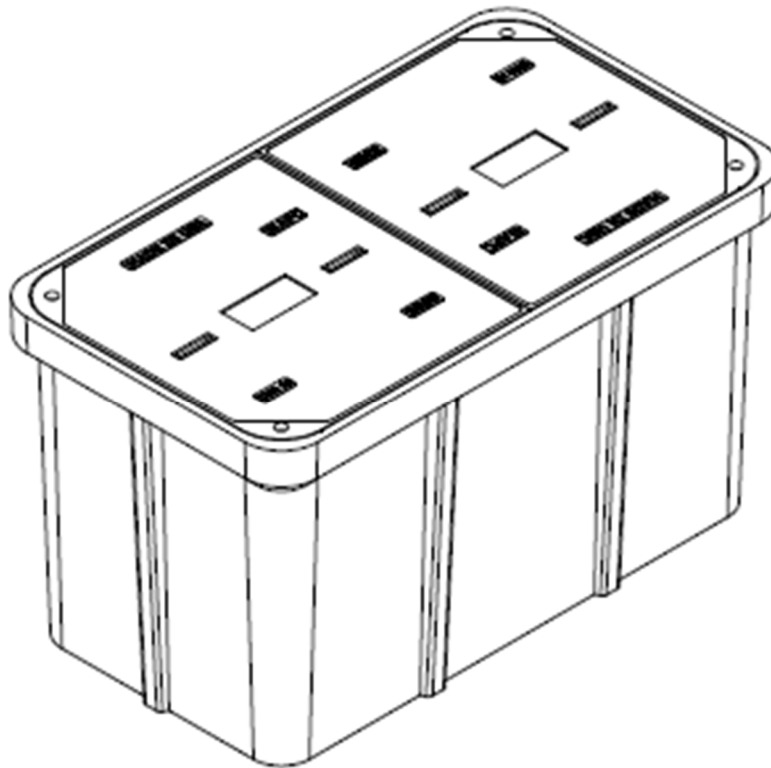

Description	Nominal Size	ANSI Tier	Part Number	Estimated Weight
PC Unit - TIER 15	33"x60"x36"	Tier 15	P336036U15...	930 lbs.
PC Unit - TIER 22	33"x60"x36"	Tier 22	P336036U22...	1030 lbs.



33"x60" PC UNIT, 2PC TIER 15/22

36" HEIGHT



AMERICAN POLYMER COMPANY

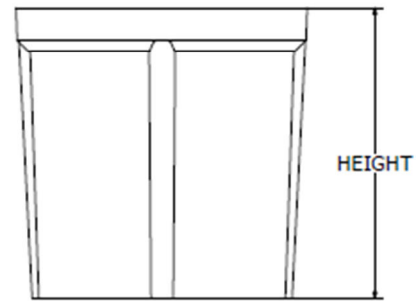
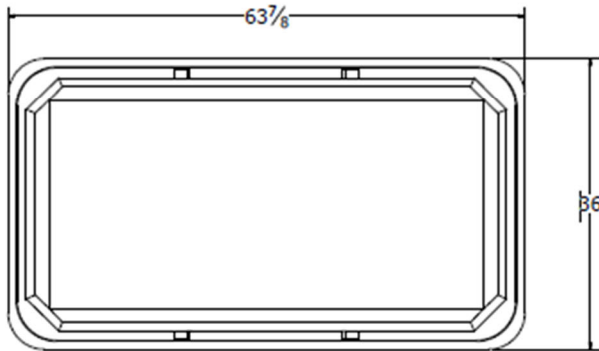
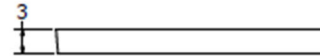
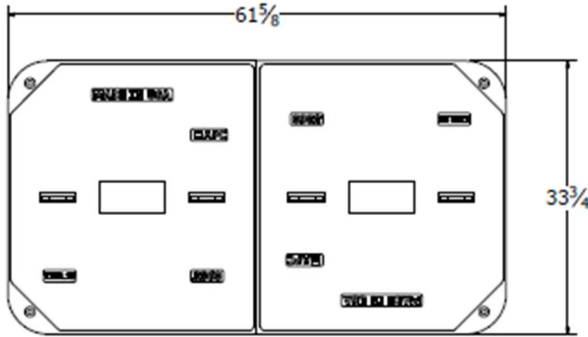

Components	Nominal Size	ANSI Tier	Part Number	Estimated Weight
Replacement Box	33"x60"x36"	Tier 22	P336036B22	530 lbs.
Replacement Lids - T15	33"x60" (half)	Tier 15	Various	200 lbs.
Replacement Lids - T22	33"x60" (half)	Tier 22	Various	250 lbs.

Bolt options

Hex Head



Machine Thread



Penta Head



Auger Thread



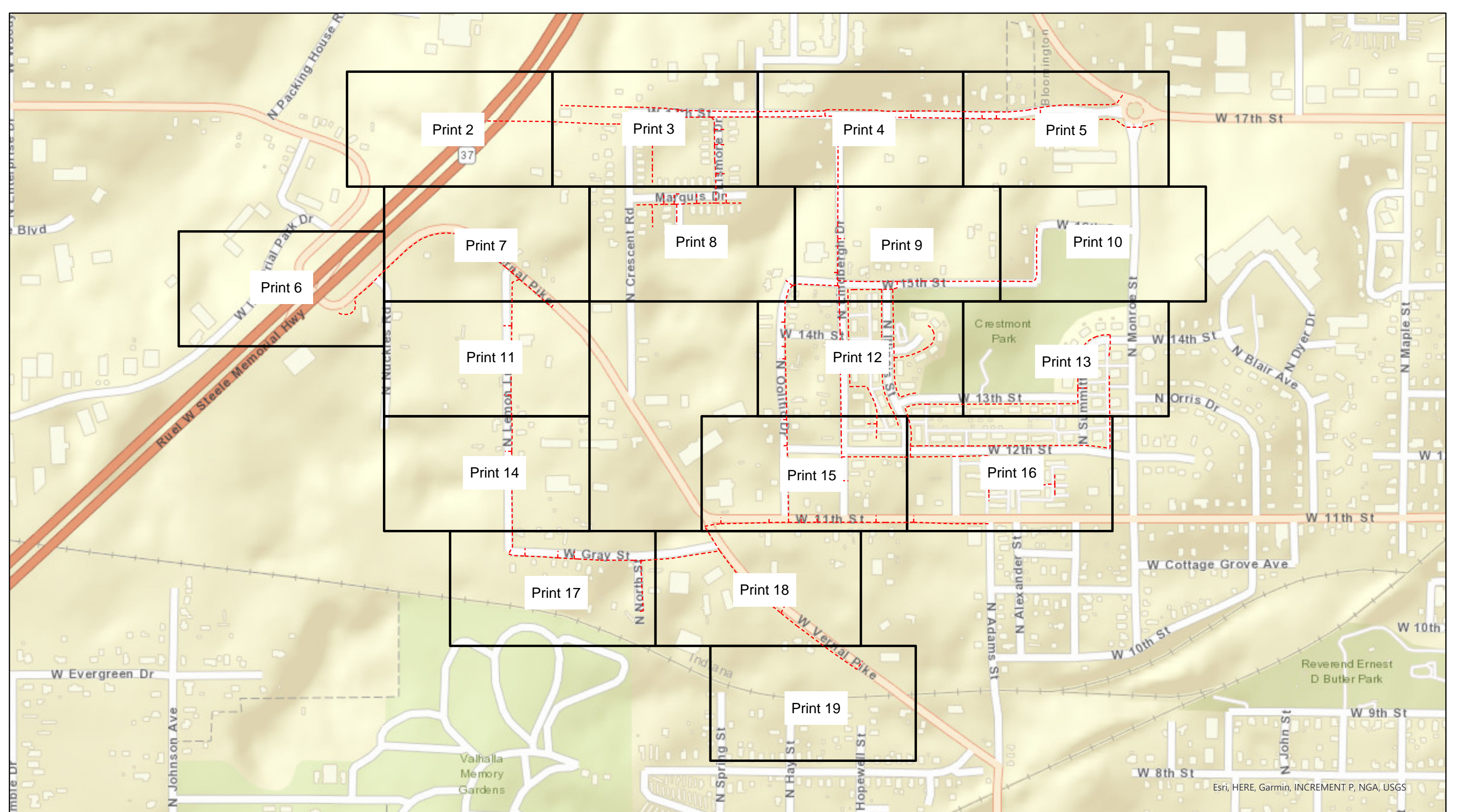

Esri, HERE, Garmin, INCREMENT P, NGA, USGS



Legend BLN01b-F13_N Crescent Rd

- Proposed Aerial
- - - Conduit
- Grids



City of Bloomington, IN Permit:
Design View

INI	BY	DATE	DESCRIPTION

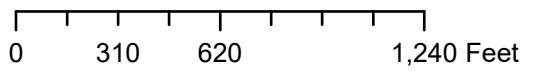

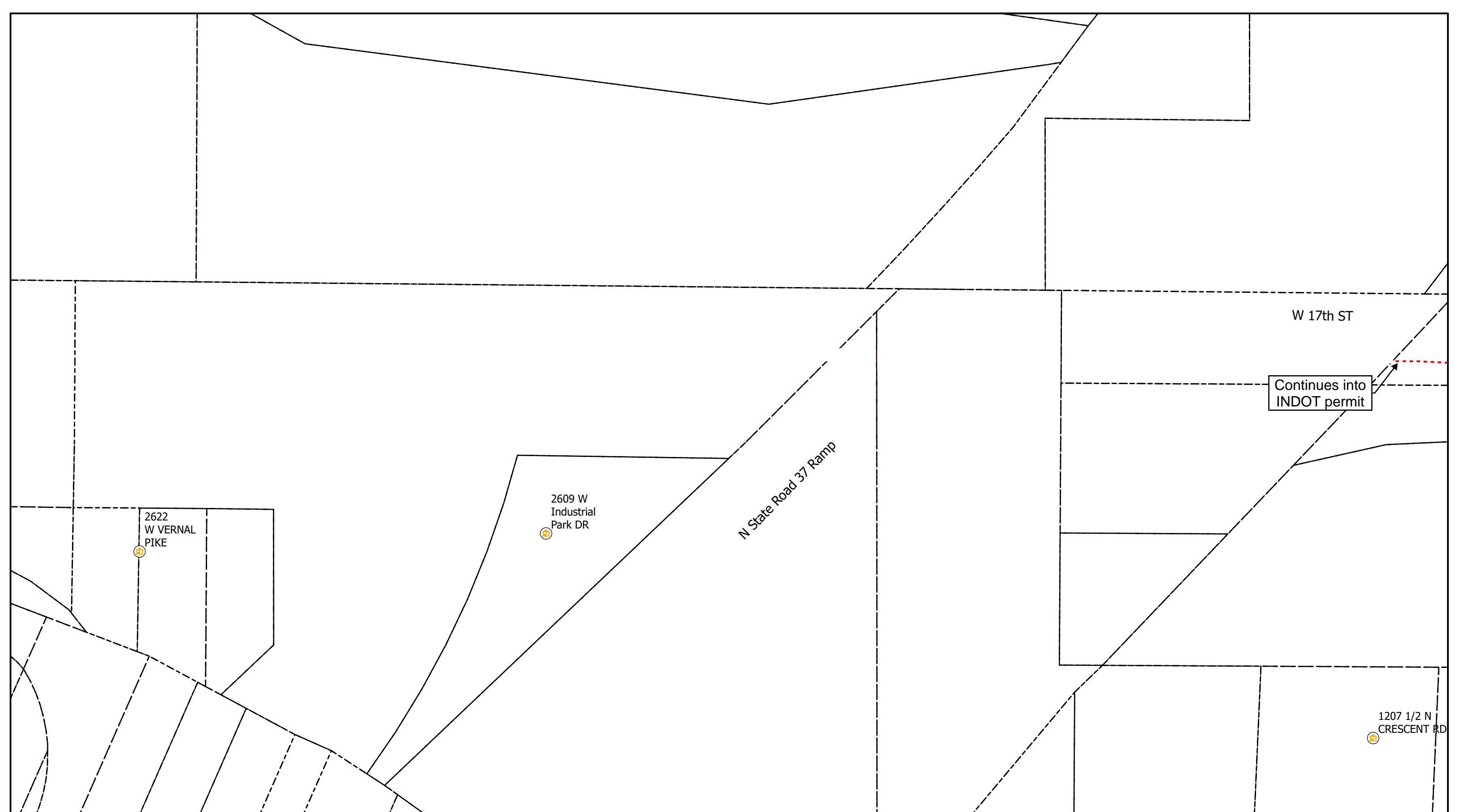



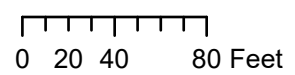





Continues into
INDOT permit



Legend

-  Vaults
-  Overhead Strand
-  Conduit
-  Risers
-  Address
-  Anchor
-  Sidewalk
-  Bloomington_Parcels
-  Grids

All Flowerpots 12" DIA



City of Bloomington, IN Permit:
Design View

INI	BY	DATE	DESCRIPTION



Continues into
INDOT permit

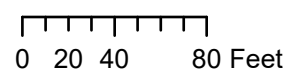
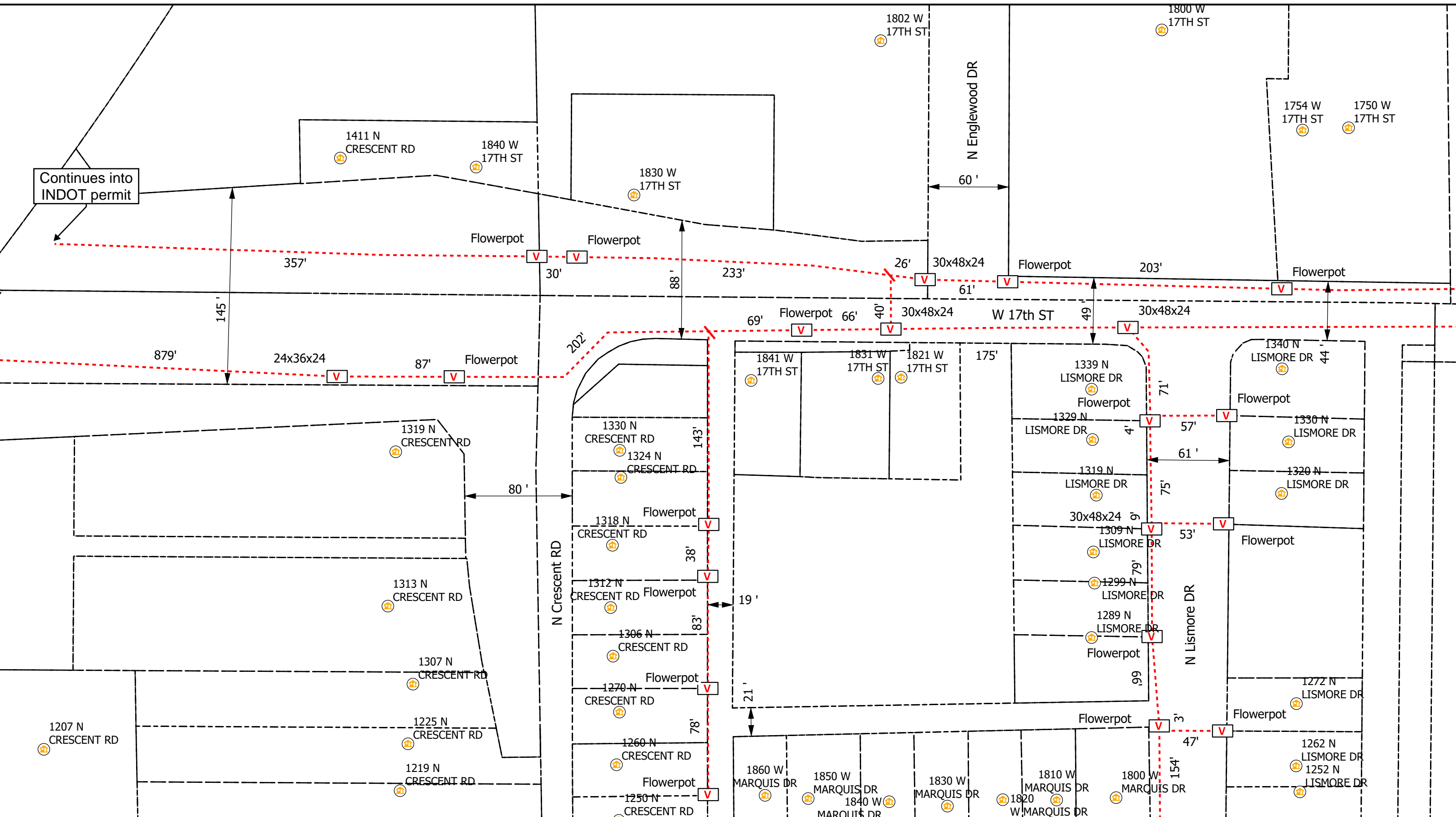

Legend

- V Vaults
- Overhead Strand
- - - Conduit
- R Risers
- 🏠 Address
- Y Anchor
- ↖ Sidewalk
- Bloomington_Parcels
- Grids

All Flowerpots 12" DIA



City of Bloomington, IN Permit:
Design View

INI	BY	DATE	DESCRIPTION



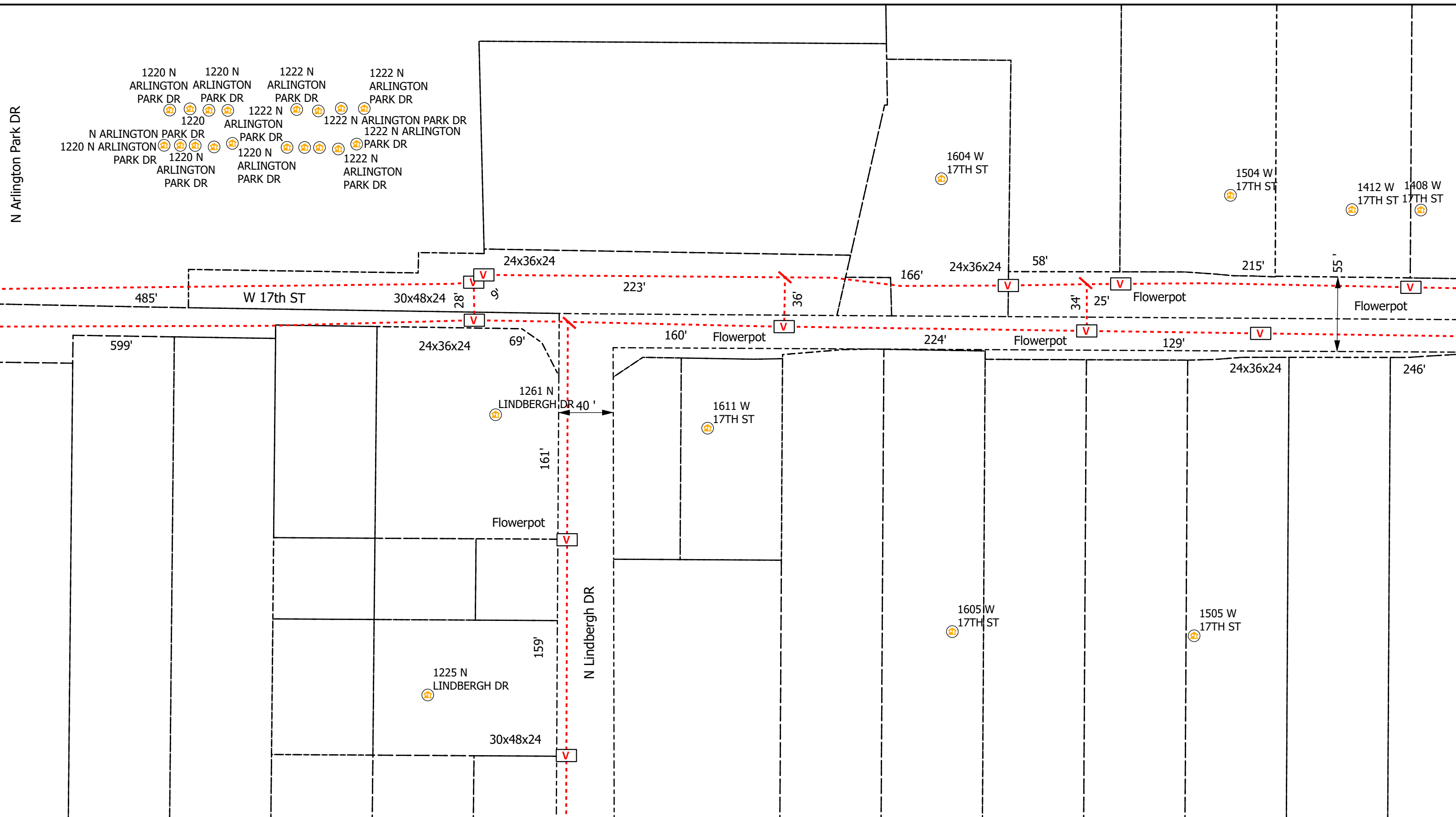

AEG

0 20 40 80 Feet

Legend

- Vaults
- Overhead Strand
- Conduit
- Risers
- Address
- Anchor
- Sidewalk
- Bloomington_Parcels
- Grids

All Flowerpots 12" DIA

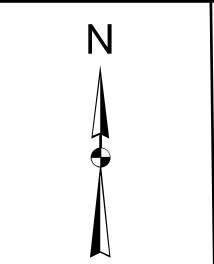

City of Bloomington, IN Permit:
Design View

INI	BY	DATE	DESCRIPTION

Print 4 of 19

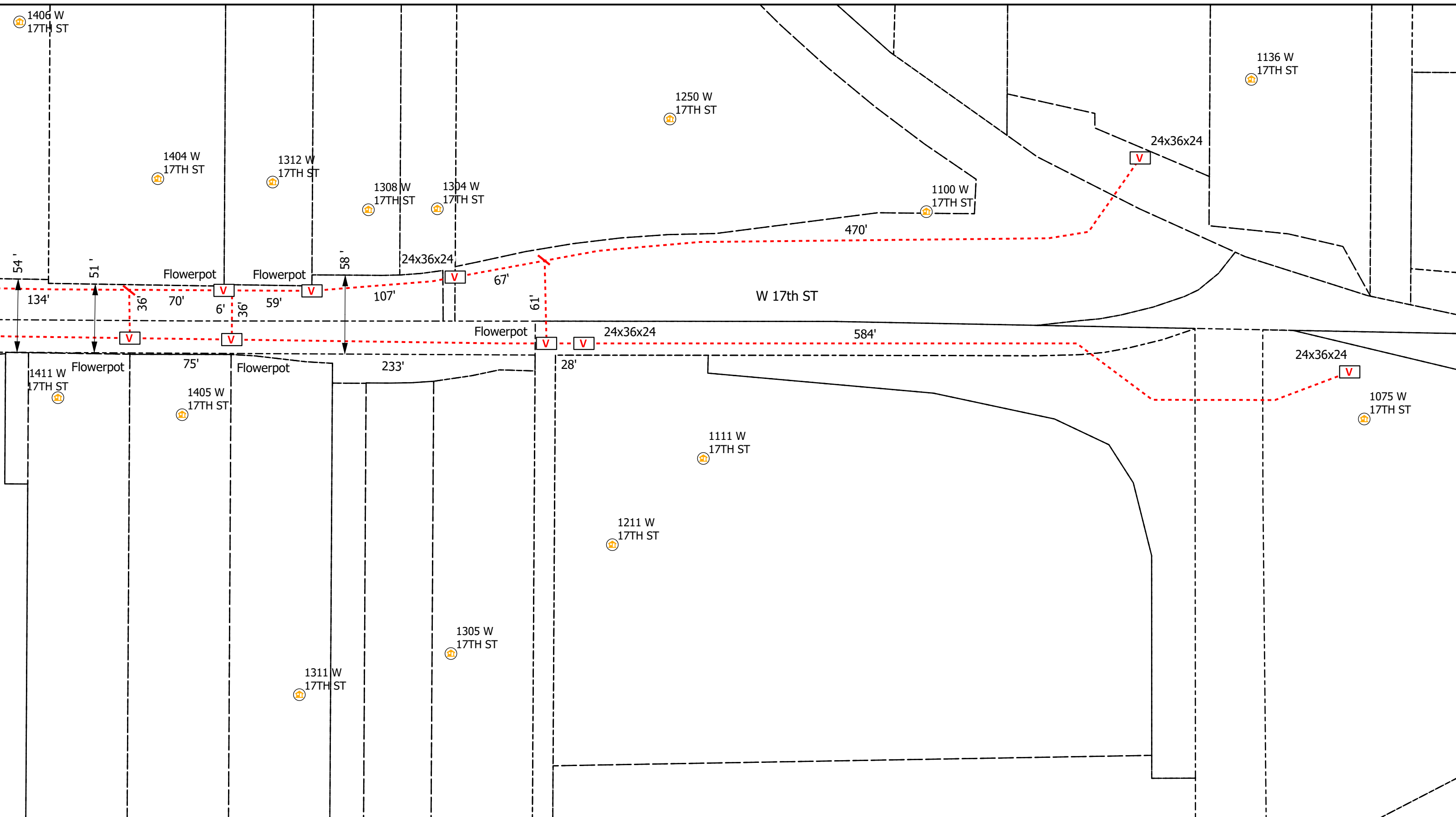

AEG

0 20 40 80 Feet

Legend

- Vaults
- Overhead Strand
- Conduit
- Risers
- Address
- Anchor
- Sidewalk
- Bloomington_Parcels
- Grids

All Flowerpots 12" DIA

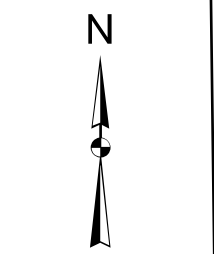

City of Bloomington, IN Permit:
Design View

INI	BY	DATE	DESCRIPTION

Indiana 811

Print 5 of 19

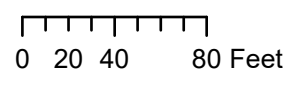
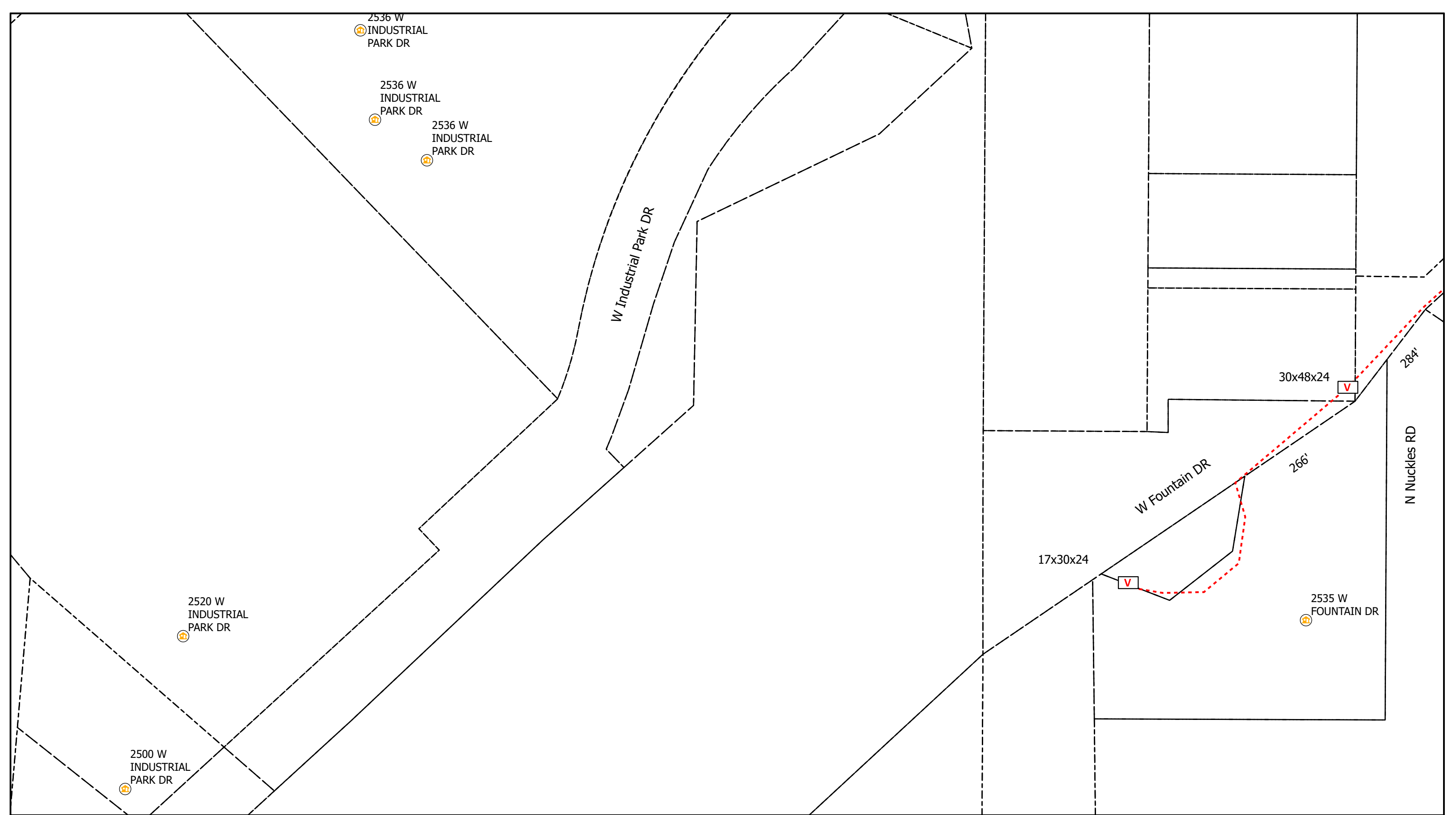

Legend

- V Vaults
- Overhead Strand
- - - Conduit
- R Risers
- 📍 Address
- Y Anchor
- ↖ Sidewalk
- Bloomington_Parcels
- Grids

All Flowerpots 12" DIA



City of Bloomington, IN Permit:
Design View

INI	BY	DATE	DESCRIPTION



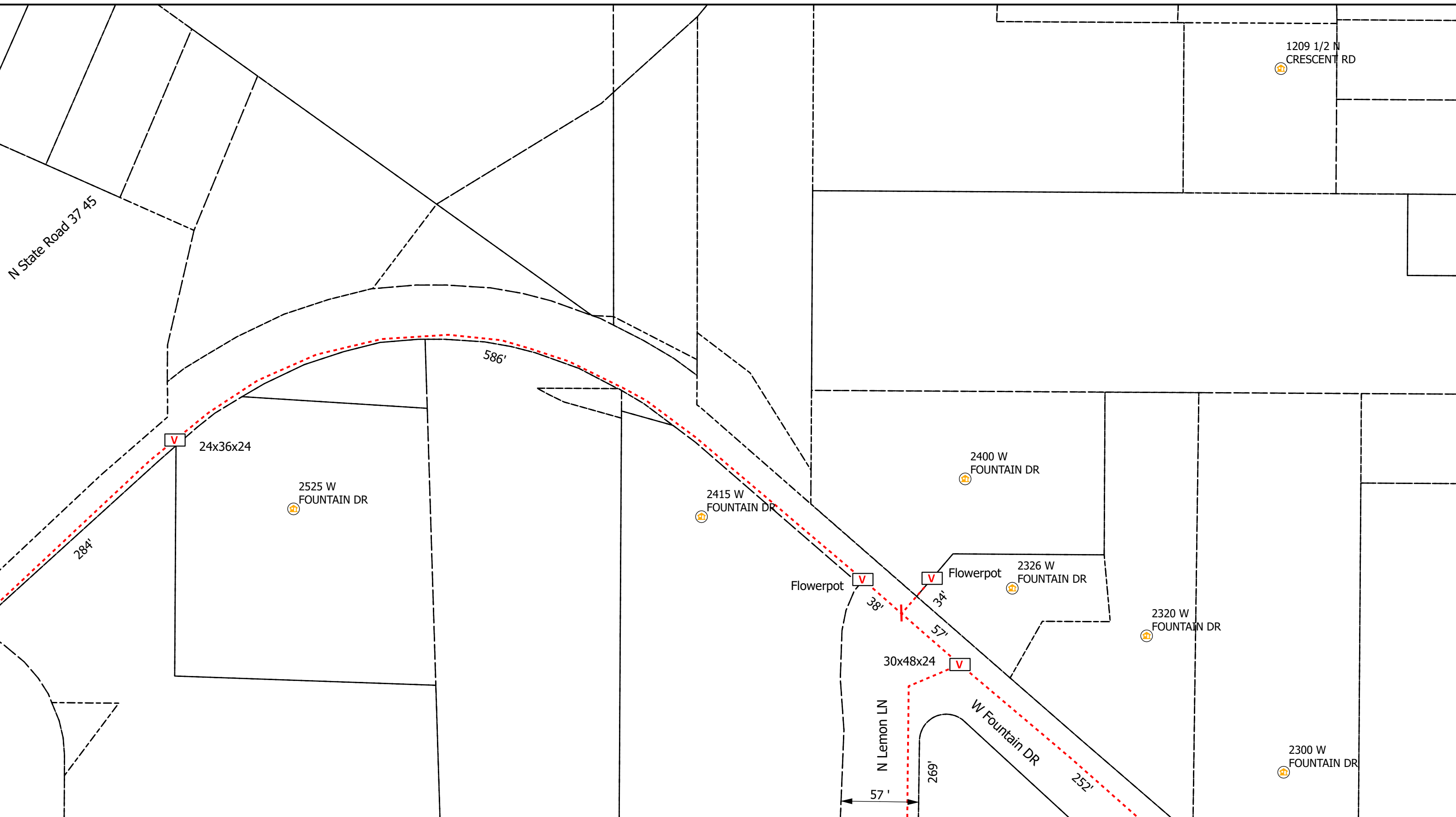

1209 1/2 W
CRESCENT RD

N State Road 37 45

24x36x24

2525 W
FOUNTAIN DR

2415 W
FOUNTAIN DR

2400 W
FOUNTAIN DR

Flowerpot
2326 W
FOUNTAIN DR

2320 W
FOUNTAIN DR

2300 W
FOUNTAIN DR

Flowerpot

30x48x24

N Lemon LN

W Fountain DR

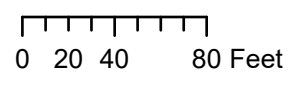

Legend

- V Vaults
- Overhead Strand
- ⋯ Conduit
- R Risers
- 🏠 Address
- Y Anchor
- ↖ Sidewalk
- Bloomington_Parcels
- Grids

All Flowerpots 12" DIA



City of Bloomington, IN Permit:
Design View

INI	BY	DATE	DESCRIPTION



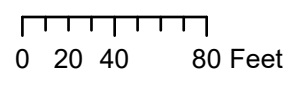
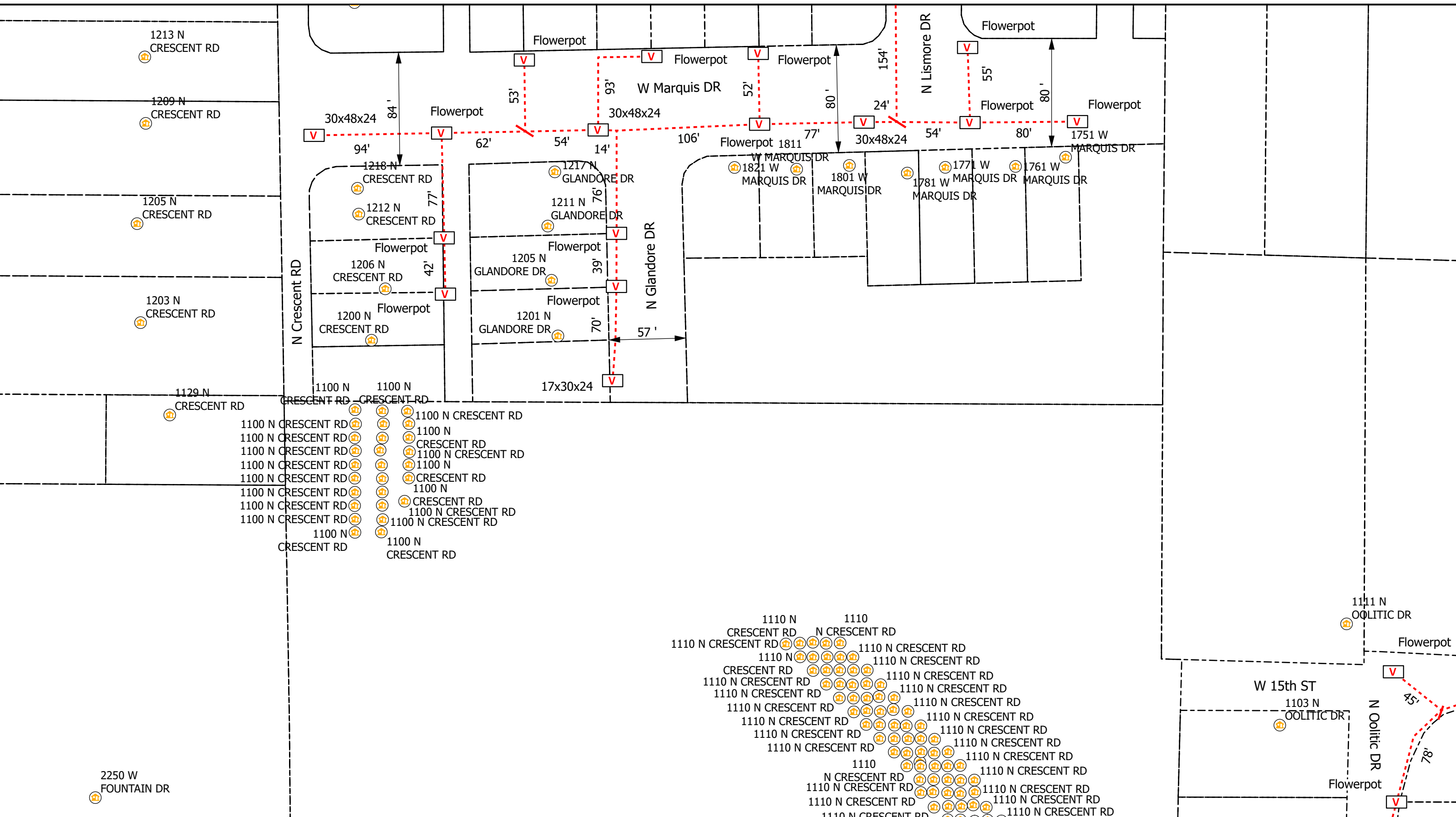

Legend

- Vaults
- Overhead Strand
- Conduit
- Risers
- Address
- Anchor
- Sidewalk
- Bloomington_Parcels
- Grids

All Flowerpots 12" DIA



City of Bloomington, IN Permit:
Design View

INI	BY	DATE	DESCRIPTION



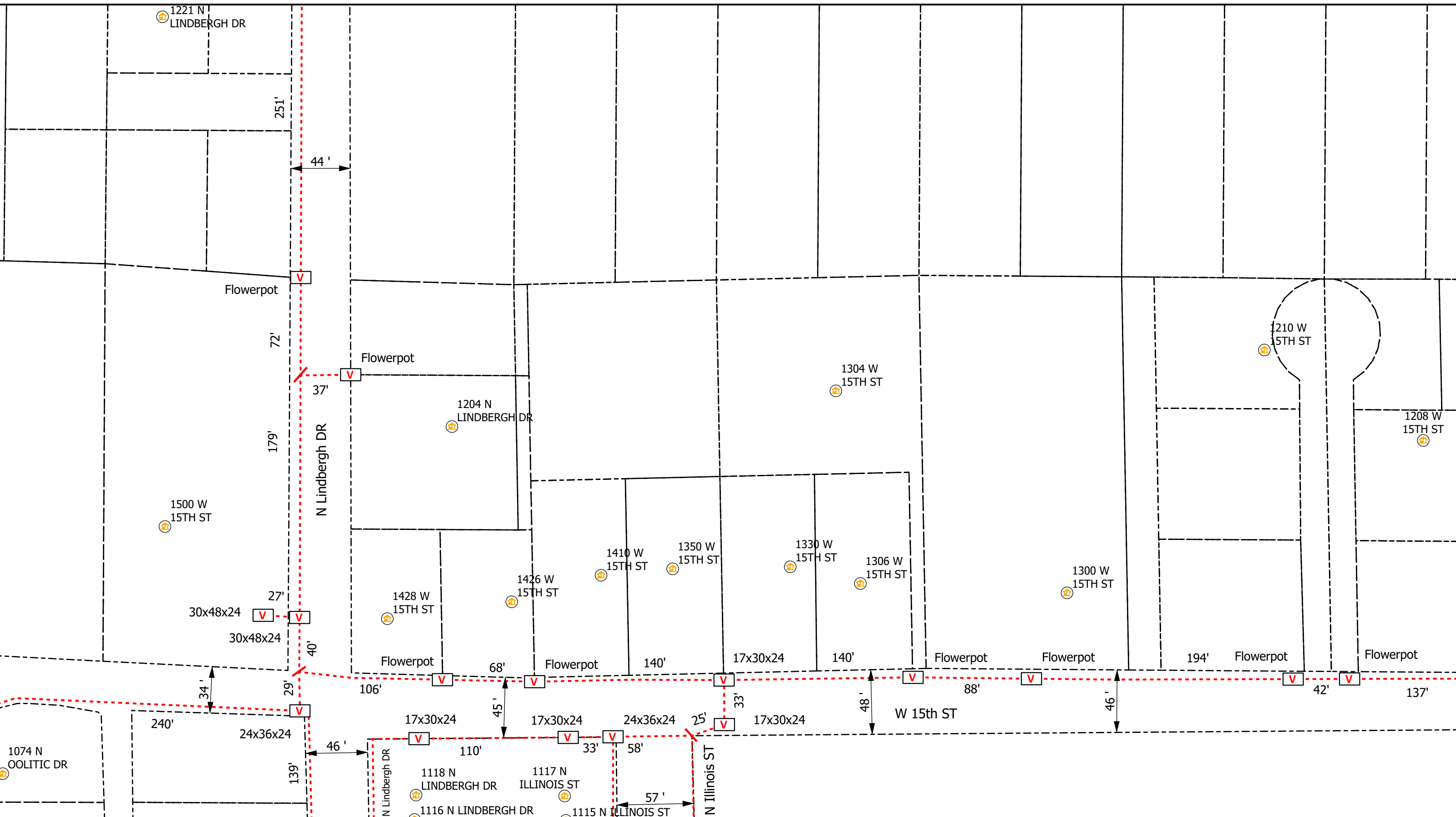

0 20 40 80 Feet

Legend

- V Vaults
- Overhead Strand
- Conduit
- R Risers
- ⊙ Address
- Y Anchor
- ↖ Sidewalk
- Bloomington_Parcels
- Grids

All Flowerpots 12" DIA

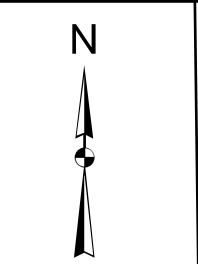

City of Bloomington, IN Permit:
Design View

INI	BY	DATE	DESCRIPTION

Print 9 of 19

1301 N
MONROE ST

N Monroe ST

Flowerpot

W 16th ST

1135 N
HANCOCK DR

30'

121'

Flowerpot

1303 N
HANCOCK DR

15'

N Hancock DR

17x30x24

293'

41'

W 15th ST

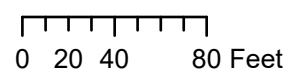

Legend

- V Vaults
- Overhead Strand
- Conduit
- R Risers
- 📍 Address
- Y Anchor
- ↖ Sidewalk
- Bloomington_Parcels
- Grids

All Flowerpots 12" DIA



City of Bloomington, IN Permit:
Design View

INI	BY	DATE	DESCRIPTION



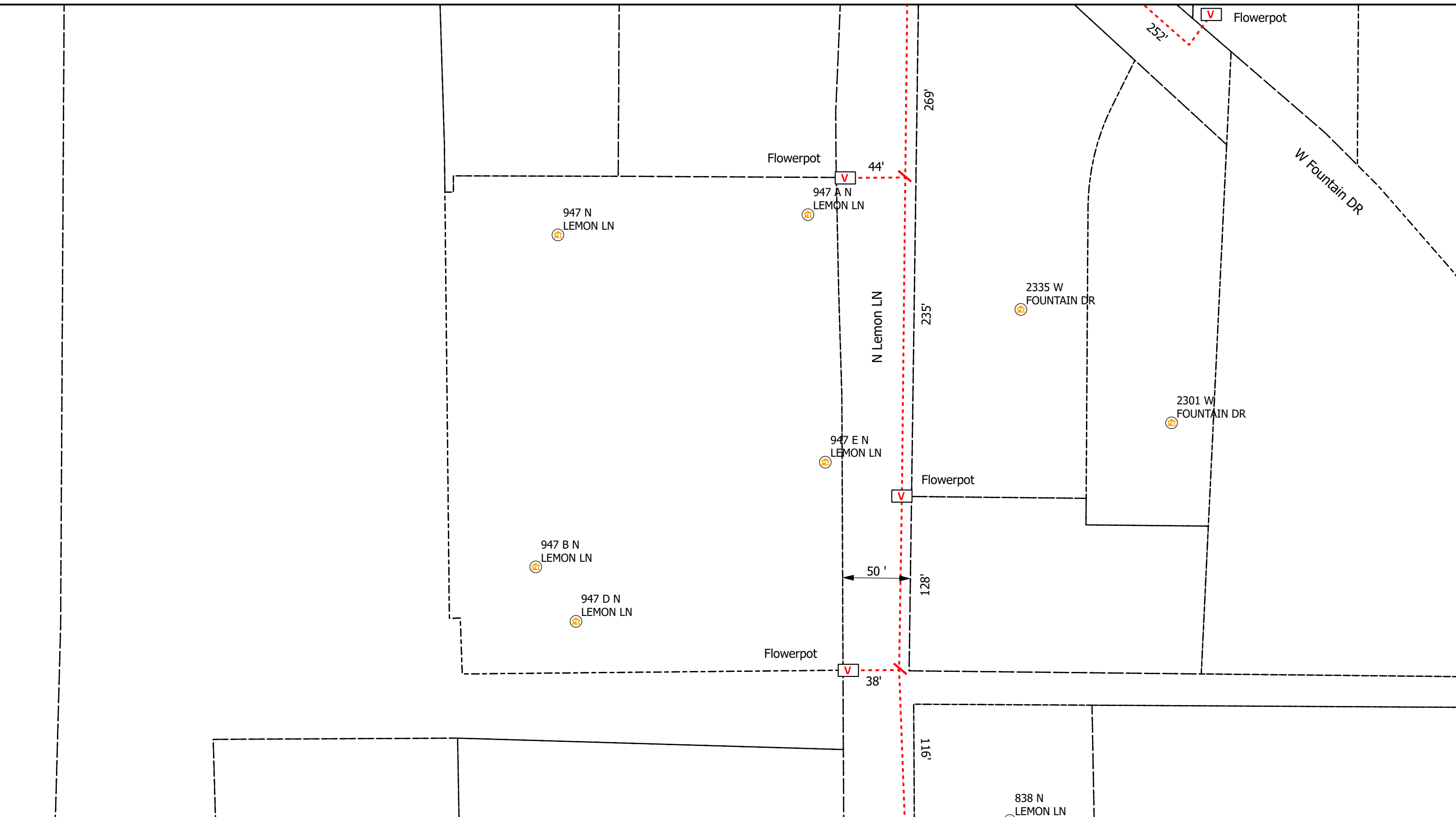

Legend

- V Vaults
- Overhead Strand
- Conduit
- R Risers
- A Address
- Y Anchor
- ↖ Sidewalk
- Bloomington_Parcels
- Grids

All Flowerpots 12" DIA

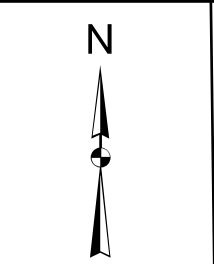

City of Bloomington, IN Permit:
Design View

INI	BY	DATE	DESCRIPTION

Print 11 of 19

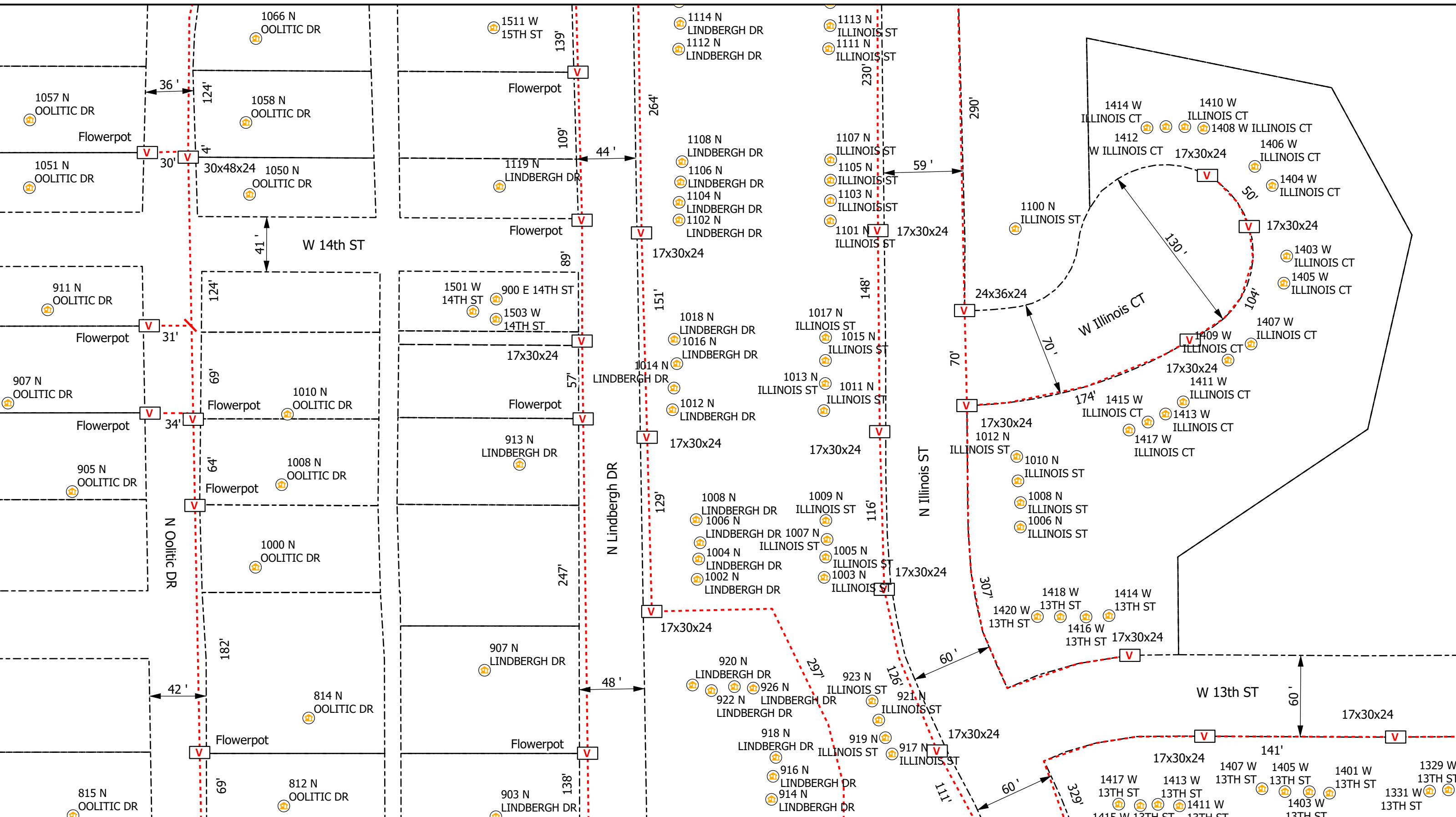

0 20 40 80 Feet

Legend

- Vaults
- Overhead Strand
- Conduit
- Risers
- Address
- Anchor
- Sidewalk
- Bloomington_Parcels
- Grids

All Flowerpots 12" DIA

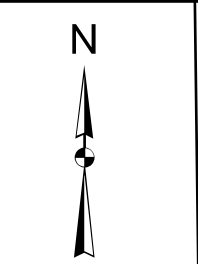

City of Bloomington, IN Permit:
Design View

INI	BY	DATE	DESCRIPTION

Print 12 of 19

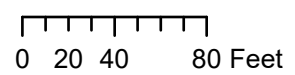
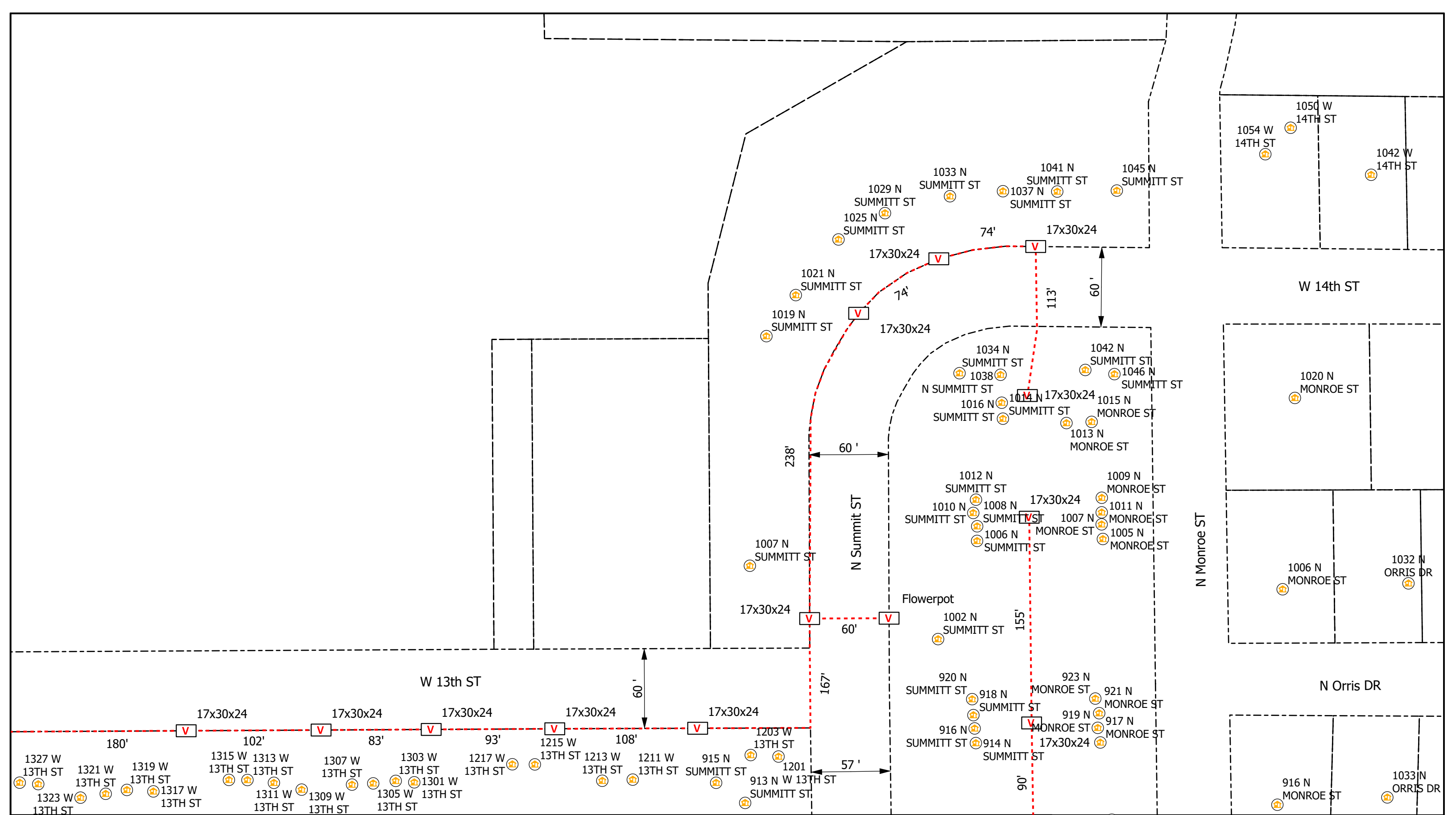

Legend

- V Vaults
- Overhead Strand
- Conduit
- R Risers
- Address
- Y Anchor
- └ Sidewalk
- Bloomington_Parcels
- Grids

All Flowerpots 12" DIA



City of Bloomington, IN Permit:
Design View

INI	BY	DATE	DESCRIPTION



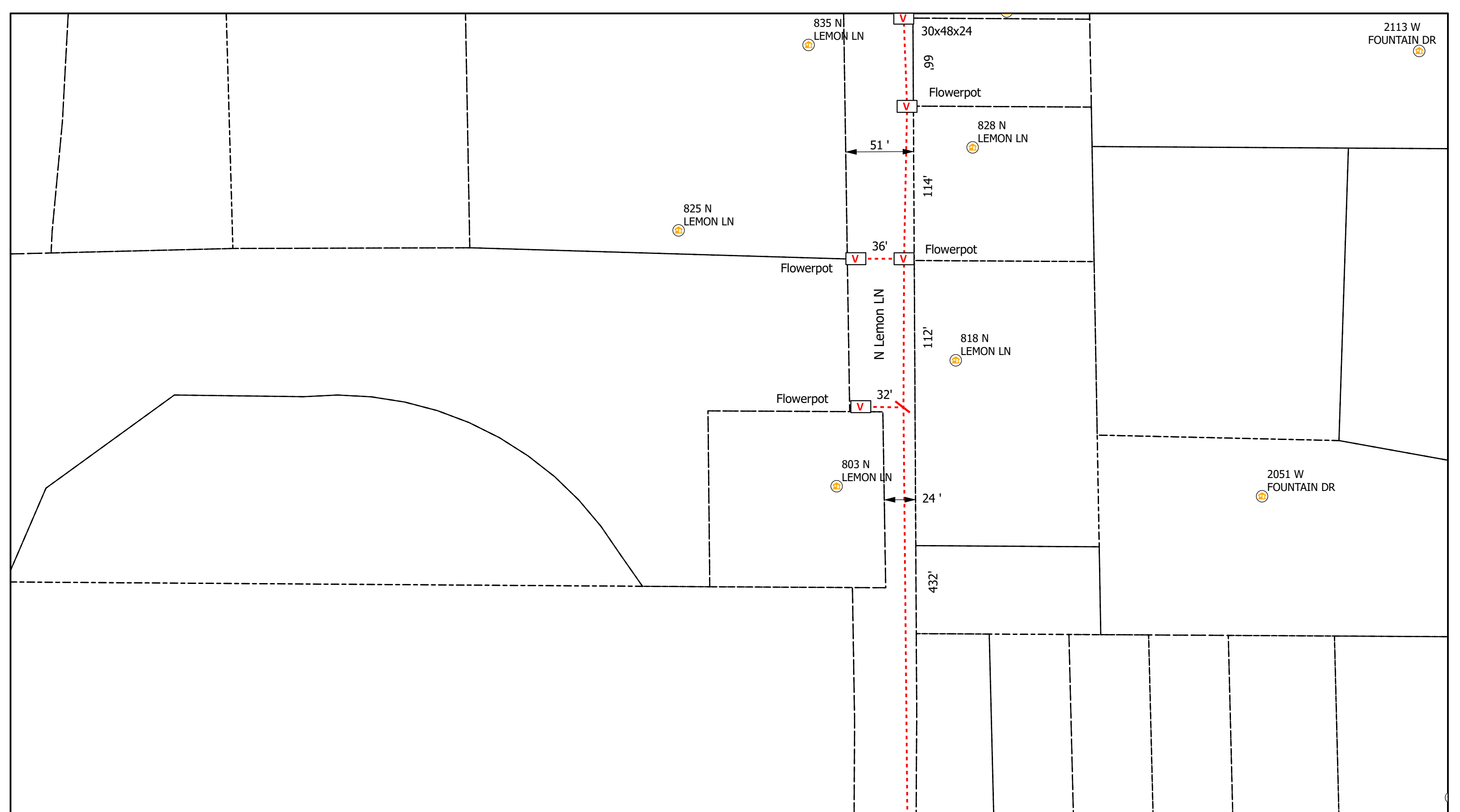

0 20 40 80 Feet

Legend

- V Vaults
- Overhead Strand
- Conduit
- R Risers
- A Address
- Y Anchor
- └ Sidewalk
- Bloomington_Parcels
- Grids

All Flowerpots 12" DIA



City of Bloomington, IN Permit:
Design View

INI	BY	DATE	DESCRIPTION



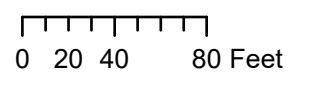
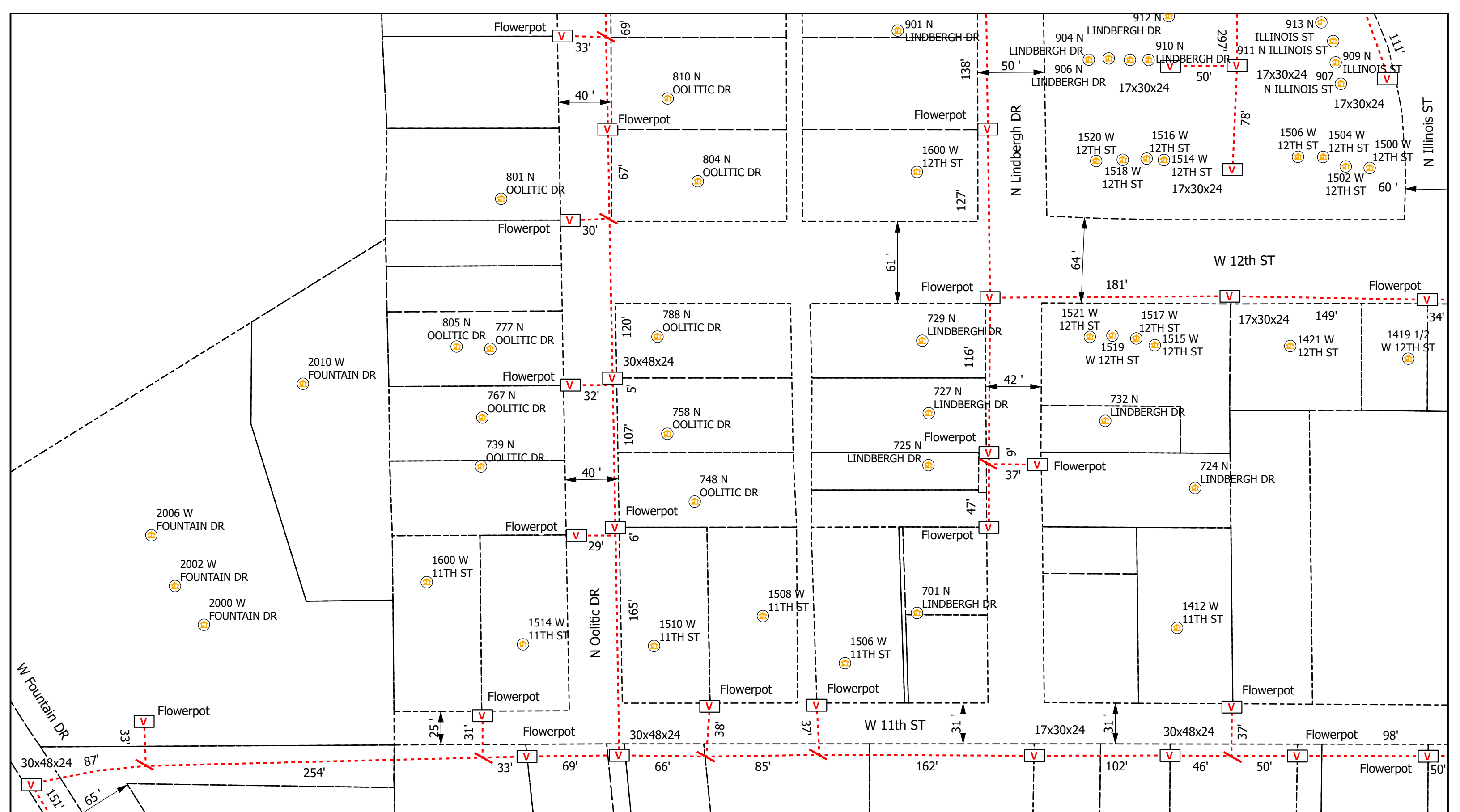

Legend

- V Vaults
- Overhead Strand
- Conduit
- R Risers
- 🏠 Address
- Y Anchor
- ↔ Sidewalk
- Bloomington_Parcels
- Grids

All Flowerpots 12" DIA



City of Bloomington, IN Permit:
Design View

INI	BY	DATE	DESCRIPTION



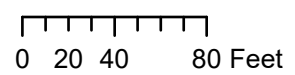
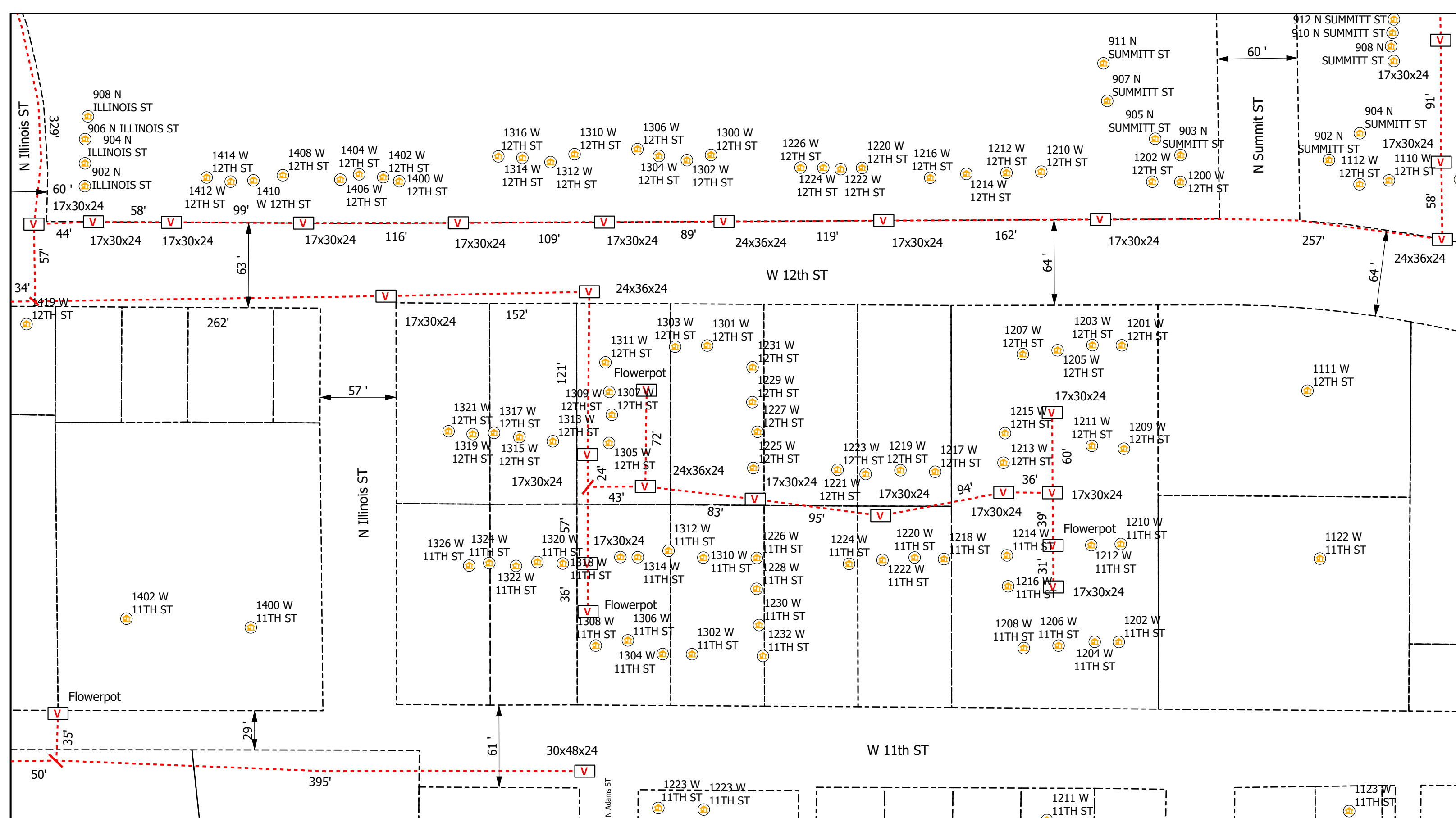

Legend

- V Vaults
- Overhead Strand
- Conduit
- R Risers
- ⊙ Address
- Y Anchor
- ↖ Sidewalk
- Bloomington_Parcels
- Grids

All Flowerpots 12" DIA



City of Bloomington, IN Permit:
Design View

INI	BY	DATE	DESCRIPTION



801 N LEMON LN

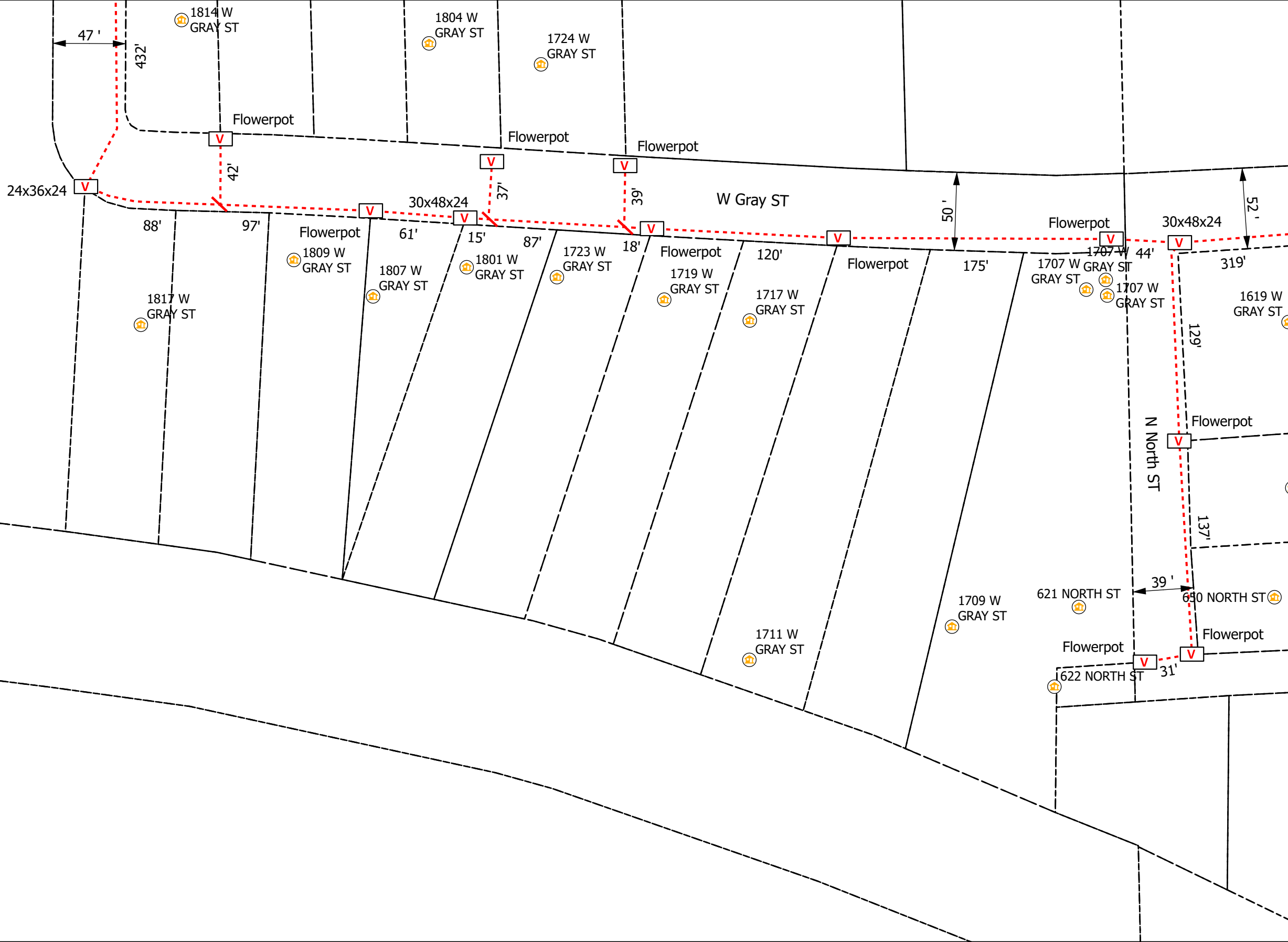

0 20 40 80 Feet

Legend

- Vaults
- Overhead Strand
- Conduit
- Risers
- Address
- Anchor
- Sidewalk
- Bloomington_Parcels
- Grids

All Flowerpots 12" DIA



City of Bloomington, IN Permit:
Design View

INI	BY	DATE	DESCRIPTION



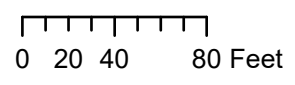
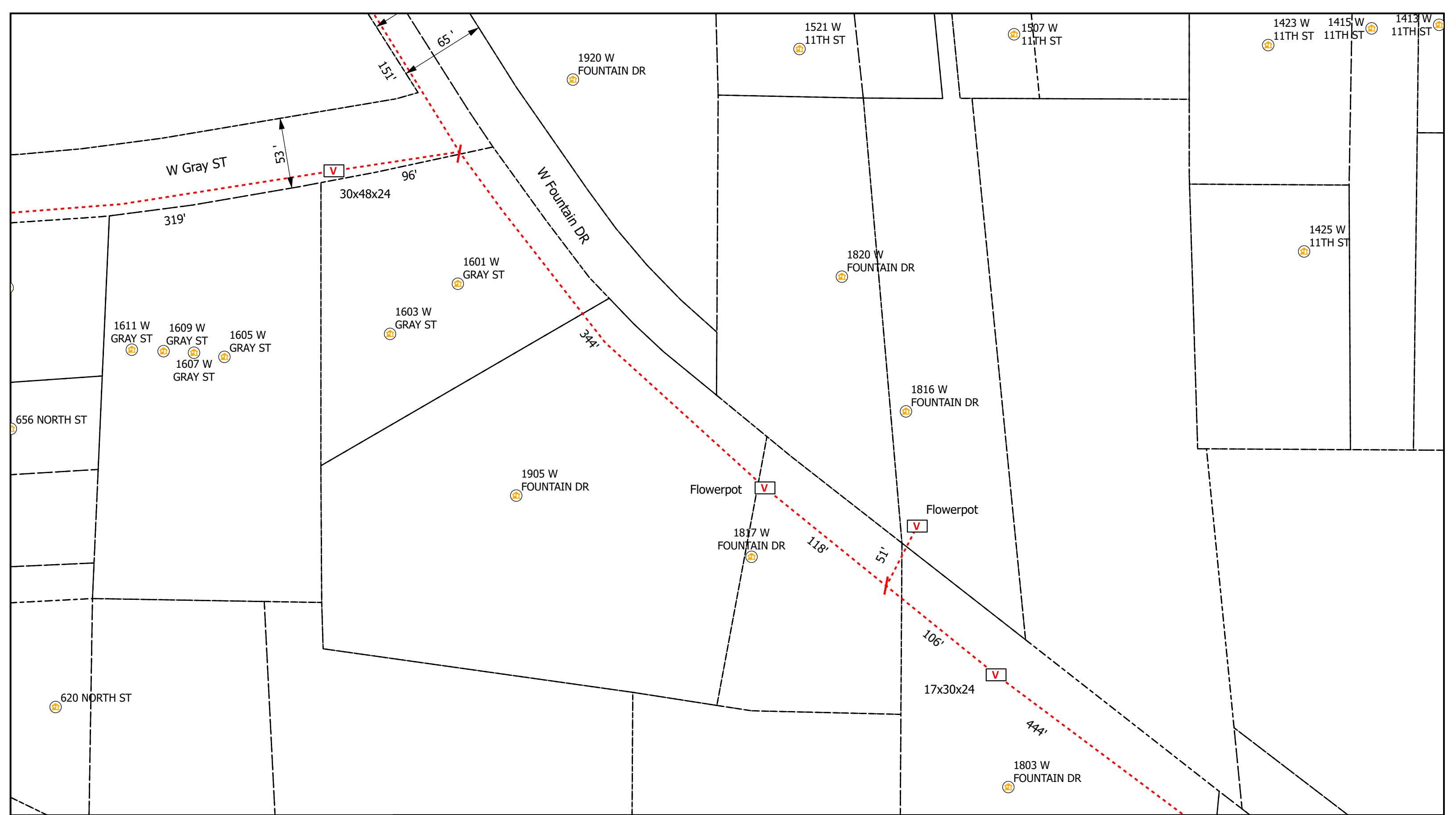

Legend

- V Vaults
- Overhead Strand
- - - Conduit
- R Risers
- 🏠 Address
- Y Anchor
- ↖ Sidewalk
- Bloomington_Parcels
- Grids

All Flowerpots 12" DIA



City of Bloomington, IN Permit:
Design View

INI	BY	DATE	DESCRIPTION



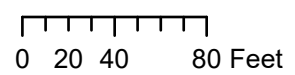
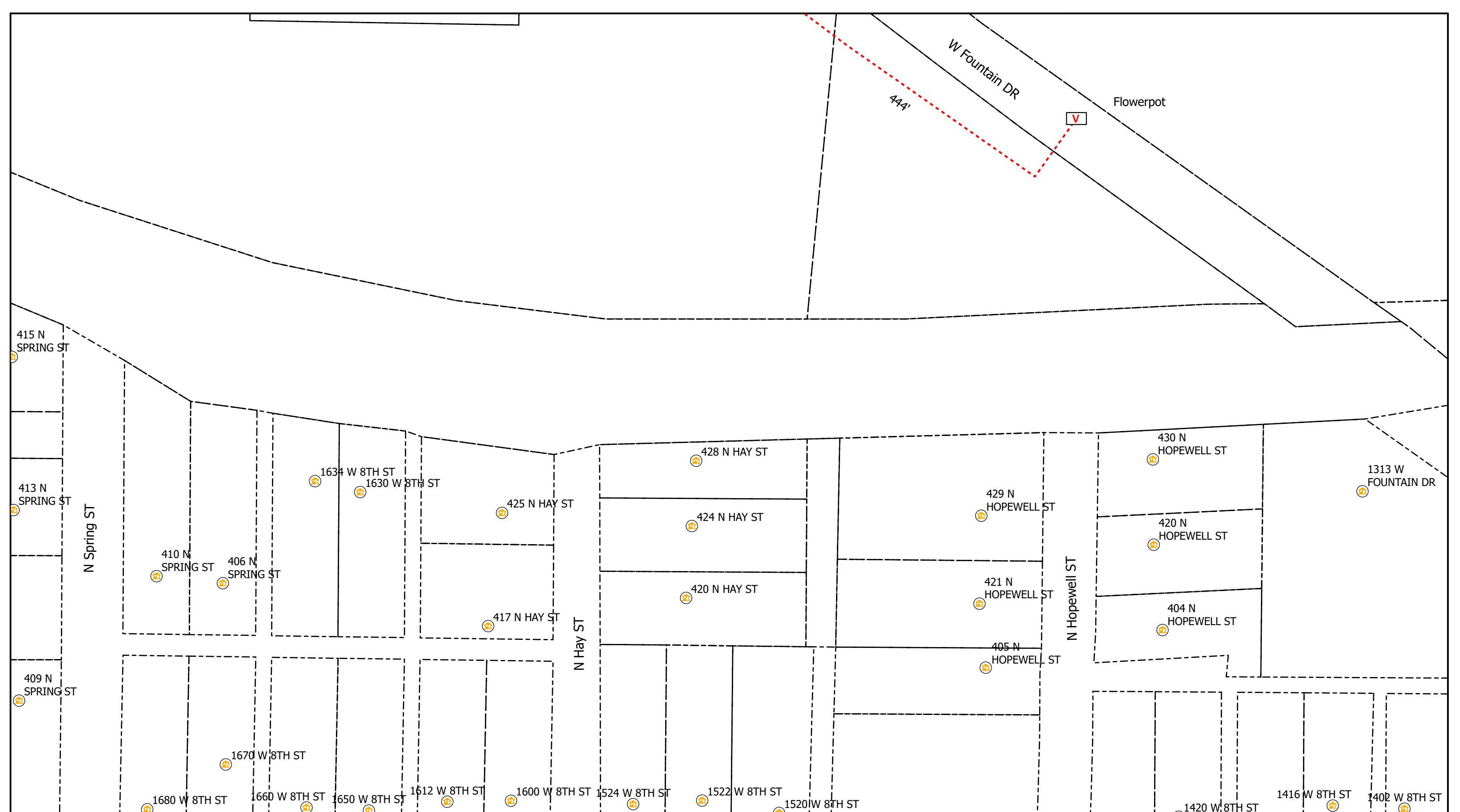

Legend

- V Vaults
- Overhead Strand
- Conduit
- R Risers
- A Address
- Y Anchor
- └ Sidewalk
- Bloomington_Parcels
- Grids

All Flowerpots 12" DIA



City of Bloomington, IN Permit:
Design View

INI	BY	DATE	DESCRIPTION





Board of Public Works Staff Report

Project/Event: Walnut St. Garage Fire Lines Replacement
Petitioner/Representative: Public Works Parking Services
Staff Representative: Jess Goodman
Date: 9/10/2024

Report: Walnut St. Garage fire lines are in need of replacement according to Applied Engineering's assessment. All fire lines will be replaced with galvanized pipes instead of black steel to last the life of the garage.

- Remove 6" main and replace with 6" 10 galvanized pipe
- Remove 4" Standpipe in NW stairs
- Replace 4" dry standpipe with 4" 10 galvanized pipe
- Replace all 2.5" hose valves
- Remove and replace ATT garage hose valve pipe and replace with 10 galvanized pipe

Recommendation and Supporting Justification: I recommend Multicraft Fire LLC for the repairs.

Cost= \$14,500.00

Recommend **Approval** **Denial by:** *Jess Goodman*



Request for Quotes

Scope of Work

Date: 07/17/2024

The City of Bloomington, Parking Garages, is soliciting quotes for: Walnut St. Parking Garage Fire Line removal and replacement, and smoke detector in lobbies connected to existing fire alarm panel.

Selected contractor shall furnish all materials, labor and tools to complete the following:

- i. Contractor shall schedule time to complete a walkthrough with the Garage Manager, Jess Goodman, within 10 days of receiving this notice. Contractor shall schedule this meeting by contacting Jess Goodman @ 812.837.7837 or goodmanj@bloomington.in.gov
- ii. Contractor shall submit a quote within 10 business days of completing the walkthrough
- iii. Contractor shall:
 - a. provide Proof of Insurance
 - b. complete a current W-9 and
 - c. complete the City of Bloomington's EFT forms.
- iv. Pricing shall display total cost and a detail of work cost by line.
- v. Contractor shall submit a detailed timeline of the project with a start and completion date.
- vi. Contractor shall submit and have an approved, by the City of Bloomington Contract Compliance Officer, Aleksandria Pratt, their written Affirmative Action Plan 24-hours prior to the submission deadline for requests.

Scope of Work

- i. Contractor shall remove all horizontal fire line piping and replace with black steel
- ii. Contractor shall replace the fire riser pipe with new cast iron in the northwest stairwell, and riser extending down to the lower parking level
- iii. Contractor shall install FDC signage so Siamese connection can be found for the Wall Hydrants.
- iv. Contractor shall connect smoke detectors to the existing fire alarm panel.
- v. Contractor shall assure work area is clean of any debris after work is completed
- vi. Contractor shall give a 7 notice to the Parking Garage Manager Jess Goodman before marking off any spaces in the garage.

DATE: August 23, 2024
TO: Jessica Goodman
Walnut Street Garage
FROM: Luke Hanley
Koorsen Fire & Security
317-542-1800
SUBJECT: Walnut Street Garage Standpipe Replacement

The following is our proposal for the above project. Please let me know if you have any questions.

Scope of Work:

Koorsen Fire & Security to provide labor and material to replace sections of the dry manual stand pipe in the parking garage.

Demo 63' feet of 6" black pipe and replace with 6" galvanized pipe. Includes replacing necessary fittings with galvanized.

Demo 4" standpipe in northwest stairwell and replace with 4" galvanized pipe. Includes new 2 1/2" hose valves.

Demo 2 1/2" standpipe in the ATT&T garage and replace with 2 1/2" galvanized pipe. Includes a new 2 1/2" hose valve.

Note*** The vertical connection of the new 6" standpipe needs to be connected to a coupling or fitting in the ATT&T space below the first level of the parking garage on the south end. This is necessary to ensure the new piping will not leak. This area did not have access during the survey. It is assumed the piping below the south end of the garage is accessible to complete the work. If not, a change order may be necessary.

Scope continued:

- Any State or local plan review fees or permits required for the installation or approval of the system is not included.
- The supply of bid or performance bonds is not included. These are available at an additional cost upon request.
- The submittal of any required drawings, correspondence, or submittals to any State, Insurer or Authority Having Jurisdiction is not included. If desired, Koorsen Fire & Security can provide these services for an additional fee.
- No retainage shall be held.
- Any trenching, backfilling, sealing, fire stopping, cutting, painting or patching required to complete the scope of work is not included.
- Supplying a scissor or boom lift required to complete Koorsen Fire & Security's scope of the work is included.
- Any Fire Watch that this project may require is not included.
- We will perform our scope of work during normal working hours, Monday through Friday, 8:00 AM to

Offering complete Design, Installation, and Service since 1946

Fire Alarm
Security and Fire Monitoring
CCTV- Video Surveillance
Card Access

Sprinkler Systems (Backflow/Hydrants/Fire Pumps)
Restaurant & Industrial Fire Suppression
Clean Agent & Special Hazards Fire Suppression
Complete Installation, Inspection & Maintenance

Exit/Emergency Lighting
Fire Extinguishers
Intercom, Sound, Data, MATV
Nurse Call

5:00 PM. Any work required to be performed at other than normal working hours will be invoiced accordingly.

- A one (1) year warranty shall be provided for labor and material only on areas serviced by Koorsen Fire & Security.
- The data contained in this proposal has been submitted in confidence. Customer will not disclose or permit disclosure of any information in this document without the prior written consent of Koorsen Fire & Security or use or permit the use of such information or data to compete with Koorsen Fire & Security in any manner.
- This proposal may be withdrawn by Koorsen Fire & Security if not accepted within 60 days of the above date.
- We have designed this system to the best of our ability and our interpretation of applicable codes. However, if the AHJ requires any additional devices, these will be a change order and extra cost.
- Customer to provide adequate access to the system control valves.
- Price based on all control valves shutting properly. Any delay performing the described due to existing faulty equipment, the customer will be billed accordingly.
- Customer to move any equipment, material, supplies, stock or anything that may be damaged by water or physical damage.
- Any additions or modifications to the hazard area(s) after installation commences will require a change order and will be billed separately.

Pricing: The total cost for material and labor will be..... \$16,940.00
This includes a ONE (1) year labor and ONE (1) year parts warranty.

Koorsen Fire & Security will bill, upon credit approval, progressively on a monthly basis until the project is complete. A mobilization deposit of up to 50% may be required prior to the job starting. After which, the job will be progressively billed monthly until job completion.

This Agreement price is calculated based on the current prices for component materials. Koorsen Fire and Security agrees to utilize a best effort to obtain materials from suppliers. However, should there be an increase in the prices of specified materials through no fault of Koorsen Fire and Security that are purchased after execution of the Agreement for use in the scope of work; the price of the Agreement shall be adjusted accordingly. Adjustments shall require written notice by Koorsen Fire and Security to the Customer, and Customer agrees to pay the adjusted price to Koorsen Fire and Security.

Offering complete Design, Installation, and Service since 1946

Fire Alarm
Security and Fire Monitoring
CCTV- Video Surveillance
Card Access

Sprinkler Systems (Backflow/Hydrants/Fire Pumps)
Restaurant & Industrial Fire Suppression
Clean Agent & Special Hazards Fire Suppression
Complete Installation, Inspection & Maintenance

Exit/Emergency Lighting
Fire Extinguishers
Intercom, Sound, Data, MATV
Nurse Call

Koorsen Fire & Security Profile:

Koorsen Fire & Security, founded in 1946, is a recognized leader in low voltage systems contracting. Our products can be found working everywhere, from high-rise buildings to the corner retail store, throughout the United States. For over 60 years, we have earned the confidence of architects, engineers, owners and contractors. Clients vary widely to include virtually every type of industrial, commercial, and institutional facility.

Koorsen has been installing low voltage electronic and suppression systems throughout the United States since 1946. Since we are a privately held distributor/contractor that is not controlled by a single manufacturer or supplier, it enables us to offer our customers a variety of products, services and suppliers. We constantly review these manufacturers and suppliers in order to provide our customers the best possible equipment to meet their needs.

Our people are our strongest resource; the quality of our products is a close second. Combining the two ensures our clients the maximum return on their product dollar. Koorsen Fire & Security wants to help you complete your integrated systems goals, on time and under budget.

Offering complete Design, Installation, and Service since 1946

Fire Alarm
Security and Fire Monitoring
CCTV- Video Surveillance
Card Access

Sprinkler Systems (Backflow/Hydrants/Fire Pumps)
Restaurant & Industrial Fire Suppression
Clean Agent & Special Hazards Fire Suppression
Complete Installation, Inspection & Maintenance

Exit/Emergency Lighting
Fire Extinguishers
Intercom, Sound, Data, MATV
Nurse Call

KOORSEN FIRE & SECURITY TERMS AND CONDITIONS

1. **AGREEMENT.** Prices per this quotation are in effect for 30 days from the date of this quote. This Agreement shall become effective upon the execution by Customer and acceptance and execution of this Agreement by a duly authorized representative of Koorsen Fire & Security. This Agreement constitutes the entire agreement between the parties and supersedes any previous agreement, understanding or order between the parties. Should the terms and conditions of any purchase order of Customer issued in connection with this Agreement conflict with the terms contained in this Agreement or add any new terms to this Agreement, such new terms or different terms shall be of no force or effect. No modification or waiver of the terms of this Agreement shall be binding unless made in writing and signed by both parties. This Agreement is made and entered into in the State of Indiana and shall be in all respects governed by and construed in accordance with the laws of the United States and the State of Indiana as if entirely performed in Indiana and without regard to any conflict of law rules and without regard to any rules of construction or interpretation relating to which party drafted this Agreement. This Agreement may not be assigned by Customer directly or indirectly (including, without limitation, by merger or sale of stock) without the prior written consent of KFS, which consent may be withheld by KFS, in its sole discretion, for any reason or no reason.
2. **SALE OF INSTALLATION AND/OR EQUIPMENT.** KFS shall sell to Customer and the Customer shall purchase from the KFS the installation ("System") and/or equipment ("Equipment") identified on the front of this Agreement. All shipments, unless otherwise specified, are quoted F.O.B. origin and may be subject to additional "hazardous material" charges or other special shipping and handling fees.
3. **PURCHASE PRICE AND PAYMENT.** Customer agrees to pay KFS the purchase price for the Equipment and/or Services set forth on the proposal or as otherwise set forth on the KFS's invoice. All charges shall be paid "NET 30 DAYS" from the date of invoice, unless otherwise specified on the invoice. A convenience fee of 3%, of the invoice amount will be charged for payments by credit card. Payments by check, cash, ACH, wire transfers or echecks are not subject to the convenience fee., If KFS retains a collection agency, legal counsel, or incurs any out-of-pocket expenses to collect overdue payments, all such collection costs shall be paid by Customer. Customer acknowledges that, other than KFS's completion of installation of a System, payment to KFS is not contingent on any occurrence, matter or event, including, without limitation, Customer's receipt of payment from any third party such as an owner or insurance company.
4. **ALLOCATION OF RISK OF LOSS.** Any risk of loss associated with the Equipment remains with KFS until the goods arrive at the place of delivery. After the goods arrive at the place of delivery, the risk shall be exclusively that of the Customer. The risk of loss remains with the Customer, even regarding Equipment that is subsequently returned to KFS, until receipt by KFS.
5. **JOBSITE, APPROVAL AND PERMITS.** Unless otherwise specified, Customer shall provide, at Customer's expense, all approvals and permits required by applicable law. Customer will make premises available without interruption during KFS normal working hours, 8:00 A.M. to 4:45 P.M., exclusive of Saturdays, Sundays, and holidays. Customer understands that the installation will necessitate drilling into various parts of the premises. KFS intends, generally, to conceal wiring in the finished areas of the premises, however, there may be areas in which due to construction, decoration, or furnishing of the premises, KFS determines, in its sole discretion, that it would be impractical to conceal the wiring and in such cases, wire will be exposed. Customer agrees to provide 110 AC electrical outlets at designated locations for equipment requiring AC power. Customer agrees to provide for lifting and replacing carpeting, if required, for installation of floor mats or wiring. Customer has the authority to engage KFS to carry out the installation in the premises. The Customer agrees to furnish any necessary electric current through the Customer's meter and at the Customer's own expense. Customer will obtain and keep in effect all permits or licenses that may be required for the installation and operation of the system. Customer has the affirmative duty to inform KFS, prior to beginning of installation, of every location at the premises where KFS' employees or agents should not (because of concealed obstructions or hazards such as pipes, wires or asbestos) enter or drill holes. If asbestos or other health hazardous material is encountered during installation, KFS will cease work until Customer, at its sole expense, obtains clearance from a licensed asbestos removal or hazardous material contractor and that continuation of work will not pose any danger to KFS personnel. In no case shall KFS be liable for discovery or exposure of hidden asbestos or other hazardous material, and Customer shall indemnify and hold KFS and its employees harmless from any claims brought against KFS and/or its employees by third parties for damages, personal injury, death, emotional injury, whether actual or prospective, allegedly caused by the presence, spread, ingestion or inhalation of any substance/vapor on or originating from Customer's premises.
6. **GRANT OF SECURITY INTEREST.** Customer, on behalf of the owner and Customer, grants to KFS a security interest in the System or Equipment to secure payment of the purchase price and grants to KFS an irrevocable power of attorney to execute and file UCC-1 Financing Statements on behalf of Customer for the benefit of KFS, as secured creditor, to protect the security interest. Upon payment in full of the purchase price, and all associated costs and charges required under this Agreement, title to the system shall pass to Customer. KFS shall have all of the rights of a secured creditor under the Uniform Commercial Code including the right to enter Customer's premises and to disable or remove the System and equipment, or both.
7. **LIMITED WARRANTY-** *Unless otherwise stated, any part of the system, including the wiring, installed under this Agreement which proves to be defective material within one (1) year of the date of completion of installation will be repaired or replaced at KFS' option with a new or functionally operative part. Labor required to repair or replace such defective components or to make mechanical adjustments to the system will be free of charge for a period of one (1) year following the completion of the original installation. This warranty is extended only to the original consumer purchaser of the system and may be enforced only by such person. To obtain service under this warranty, call or write our local KFS Service Department at the telephone number or address found in your local yellow pages. This warranty is void if the system is inspected, tested, or serviced by anyone other than Koorsen Fire & Security during the warranty period. **THE ABOVE LIMITED WARRANTY IS IN LIEU OF ALL OTHER EXPRESSED WARRANTIES. THERE ARE NO WARRANTIES WHICH EXTEND BEYOND THE FACE HEREOF, AND KFS DISCLAIMS ANY IMPLIED WARRANTIES OF MERCHANTABILITY AND FITNESS FOR A PARTICULAR PURPOSE***
8. **BREACH BY KFS.** Customer expressly agrees that no action at law or in equity shall be maintained by Customer against KFS for KFS's alleged breach of this Agreement or violation of any federal or state law now in effect or hereafter enacted with respect to any obligation or duty incurred under this Agreement by KFS, unless: (i) Customer notifies KFS in writing at the address specified in this Agreement within ten (10) days from date of such alleged breach or violation, and provided KFS does not remedy or correct the breach or violation within sixty (60) days from the receipt of the notice; and (ii) such action at law or in equity is commenced by Customer within one (1) year from the finished date of the installation of the System.
9. **LIMITATION OF LIABILITY.** THE AMOUNTS PAYABLE TO KFS HEREIN UNDER ARE BASED UPON THE VALUE OF THE SERVICES AND THE SCOPE OF LIABILITY AS HEREIN SET FORTH AND ARE UNRELATED TO THE VALUE OF THE CUSTOMER'S PROPERTY OR PROPERTY OF OTHERS LOCATED IN CUSTOMER'S PREMISES. IT IS IMPRACTICAL AND EXTREMELY DIFFICULT TO FIX THE ACTUAL DAMAGES, IF ANY, WHICH MAY PROXIMATELY RESULT FROM FAILURE ON THE PART OF KFS TO PERFORM ANY OF ITS OBLIGATIONS HEREUNDER. THE CUSTOMER DOES NOT DESIRE THIS CONTRACT TO PROVIDE FOR FULL LIABILITY OF KFS AND AGREES THAT KFS SHALL BE EXEMPT FROM LIABILITY FOR LOSS, DAMAGE OR INJURY DUE DIRECTLY OR INDIRECTLY TO OCCURRENCES, OR CONSEQUENCES THEREFROM WHICH THE SERVICE OR SYSTEM IS DESIGNED TO DETECT OR AVERT. IF KFS

SHOULD BE FOUND LIABLE FROM LOSS, DAMAGE OR INJURY DUE TO A FAILURE OF SERVICE OR EQUIPMENT IN ANY RESPECT, ITS LIABILITY SHALL BE LIMITED TO A SUM EQUAL TO 10% OF THE ANNUAL SERVICE CHARGE OR \$500.00, WHICHEVER IS GREATER, AS THE AGREED UPON DAMAGES AND NOT AS A PENALTY, AS THE EXCLUSIVE REMEDY, AND THAT THE PROVISIONS OF THIS PARAGRAPH SHALL APPLY IF LOSS, DAMAGE OR INJURY, IRRESPECTIVE OF CAUSE OR ORIGIN, RESULTS DIRECTLY OR INDIRECTLY TO PERSON OR PROPERTY FROM PERFORMANCE OR NONPERFORMANCE OF OBLIGATIONS IMPOSED BY THIS CONTRACT OR FROM NEGLIGENCE, ACTIVE OR OTHERWISE, OF KFS, ITS AGENTS OR EMPLOYEES. FOR REPAIR, TESTING, OR INSTALLATION OF ANY SPRINKLER SYSTEM AND ITS PARTS, IT IS CUSTOMER'S RESPONSIBILITY TO SHOW KFS ALL DRAIN VALVES, INCLUDING THOSE HIDDEN ABOVE THE CEILING OR IN A WALL. KFS WILL NOT BE RESPONSIBLE FOR WATER DAMAGE CAUSED FROM ANY UNDISCLOSED DRAIN VALVE, WHETHER OR NOT IT WAS KNOWN TO CUSTOMER.

10. INDEMNIFICATION. Customer indemnifies KFS, holds KFS harmless, and agrees to defend KFS from and against any and all lawsuits, proceedings (including, without limitation, civil, criminal, administrative and investigative proceedings, whether threatened, pending or completed), claims demands, losses, damages (including, without limitation, indirect, direct, special and consequential damages and insurance deductibles), actions, liabilities (including without limitation, strict liability and joint and several liability), costs and expenses (including, without limitation, fines, penalties and the reasonable costs of investigation, court costs, costs of arbitration, costs of appeal, and reasonable attorneys' fees) (collectively referred to as "Damages") arising out of or relating to, directly or indirectly: a breach of the Agreement by Customer; or the action or inaction of KFS in the performance of the installation of the System; provided that this provision shall not apply to Damages arising out of or relating to the recklessness or willful misconduct of KFS, when deemed by a court of competent jurisdiction to have materially and directly contributed to the Damages. As used in this paragraph, the term "KFS" shall include KFS's employees, agents, representatives, shareholders, officers, directors and subcontractors, at any level, and the subcontractor's representatives, agents, employees, shareholders, officers and directors. This provision shall survive completion of the work and the termination of the Agreement, for any reason.
11. INSURANCE. IT IS UNDERSTOOD THAT KFS IS NOT AN INSURER, THAT IT SHALL SPECIFICALLY BE THE OBLIGATION OF CUSTOMER TO PURCHASE ANY INSURANCE WHICH CUSTOMER DESIRES TO PROTECT ITSELF FROM LOSS, DAMAGE OR INJURY DUE DIRECTLY OR INDIRECTLY TO OCCURRENCES OR CONSEQUENCES THEREFROM, WHICH THE SERVICE OR SYSTEM IS DESIGNED TO DETECT OR AVERT.
12. SUBROGATION. Each party waives rights of subrogation against the other party to the extent of their respective first party insurance coverages, for any and all losses suffered by either party, whether or not caused by the negligence of the Customer or KFS or those for whom they are responsible; provided that this release shall be in force and effect only with respect to loss or damage occurring during the time each parties' insurance policies contain a clause to the effect that this release shall not affect said policies or the right of the insured to recover.

13. CONSENT TO VENUE. Customer consents to the exclusive jurisdiction and venue of Courts of the State of Indiana and Marion County with respect to the enforcement of this Agreement, the collection of any amounts due under this Agreement or any disputes arising under this Agreement. Customer agrees that effective service of process may be made upon Customer by U.S. Mail at the address on the front of this Agreement.
14. USE OF DESIGNS AND DATA. Any knowledge or information, including drawings and data, which KFS shall have disclosed or may hereafter disclose to Customer, incident to installation of the System, shall be deemed to be KFS's confidential and proprietary information and Customer shall take any and all steps as are reasonable to protect the confidentiality of such information and shall not disclose to any other person, or use, such information. KFS does not grant to Customer any reproduction rights or any rights to use such information.
15. SERVICES NOT INCLUDED.
 - A. When a labor price is submitted, it is based on all work being performed during a five (5) day forty (40) hour work week. If overtime or premium time is performed, an additional charge will be made to the Customer. Normal work weeks are 8 a.m. to 4:45 p.m., Monday through Friday, except holidays.
 - B. Unless otherwise specifically provided in the Proposal, Customer agrees to do all necessary patching of masonry work, painting, carpentry work and the like.
 - C. If applicable, Customer shall also provide a wiring, conduit and labor to connect the provided pressure switches to an equipment to be turned on or off such as alarms, motors, conveyors, fans or cooking equipment.
 - D. If applicable, Customer shall also provide necessary hardware and linkage to permit automatic closing of doors, windows, duct dampers, etc, upon actuation of any provided pressure release trip device. Unless specifically indicated in the Proposal, services do not include costs for any discharge or concentration tests required by approval authorities.
 - E. No provision to exhaust any discharged agent is included in this Proposal.
 - F. Should an employee of KFS be required to attend a "right to know" session at Customer's location, a surcharge will be added to the final invoice.
 - G. THIS PROPOSAL/ESTIMATE IS BASED ON NON-UNION WAGES. IF KFS IS REQUIRED TO PAY DIFFERENT WAGES, SUCH AS PREVAILING WAGES UNDER THE GUIDELINES OF THE US DEPT. OF LABOR, FOR ANY PORTION OF THIS WORK, KFS RESERVES THE RIGHT TO REPRICE ACCORDINGLY.
16. MECHANICS' LIEN NOTICE. Where KFS is a subcontractor, the Customer acknowledges, agrees and personally accepts service of this Agreement on behalf of the owner of the real property at which the System is to be installed and understands KFS's intention to file a Mechanic's Lien if and when KFS is not paid. The subcontractor is KFS, and the contractor is the Customer, and the amount claimed will be the balance due under this Agreement and any amendments or change orders as of the date of filing a Mechanic's Lien claim. Customer agrees to promptly notify the owner of the premises on which work is to be performed of this Mechanics' Lien Notice.

Acceptance	For Customer	For Koorsen Fire & Security
Date:	_____	_____
Printed Name:	_____	_____
Signature:	_____	_____
PO Number:	_____	_____
Company Name:	_____	Koorsen Fire & Security
Address:	_____	_____
City, State, ZIP:	_____	_____



Aug 7, 2024

Walnut Street Garage Standpipe replacement

Multicraft Fire is pleased to offer the following quote:

- Remove 6" main and replace with 6" sch 10 galvanized pipe
- Remove 4" Standpipe in NW stairs
- Replace 4" dry standpipe with 4" sch 10 galvanized pipe
- Replace all 2.5" hose valves
- Remove and replace ATT garage hose valve pipe and replace with sch 10 galvanized pipe
- Remove all scrap and material from site.
- **We assume that all work to be done regular business hours Monday-Friday 7-3:30PM**

Includes:

- labor, transportation, equipment, supervision, supplies, and materials

We exclude these items:

Painting
Electrical work or wiring
Temp Sprinkler Protection
Fire Watch
Design

The price is good for 30 days, after that date we will retain the right to review our price.

Total Price \$14500.00

We include all labor and material.

Thanks,
Chris Huskisson
MultiCraft Fire

Sign: _____

**SERVICE AGREEMENT BETWEEN CITY OF BLOOMINGTON, DEPARTMENT OF
PUBLIC WORKS, PARKING SERVICES DIVISION AND
MultiCraft Fire, LLC**

This Agreement, by and between the City of Bloomington, Department of Public Works, Parking Services Division through the Board of Public Works (the “Department”), and MultiCraft Fire, LLC (“Contractor”), is effective upon execution by both parties.

Article 1. Scope of Services Contractor shall perform removal and replacement services of the following types: remove all fire lines except in the south east stairwell in the Walnut St. garage. Remove and replace all six inch fire lines and replace with galvanized pipe, remove and replace all four inch standpipes in northwest stairwell with galvanized pipe, replace all 2.5 inch hose valves, and remove and replace garage hose valve pipe and replace with galvanized pipe in the ATT lot. These services will be performed at Walnut Street Parking Garage for a set price of Fourteen Thousand and Five Hundred dollars (\$14,500.00). Contractor shall diligently provide the Services under this Agreement and shall complete the Services described in this Agreement in a timely manner consistent with the Standard of Care identified in Article 2. Contractor shall complete the Services required under this Agreement on or before, December 31, 2024 unless the parties mutually agree to a later completion date. Completion shall mean completion of all work related to the Services. In the performance of Contractor’s work, Contractor agrees to maintain such coordination with the Department as may be requested and desirable, including primary coordination with Jess Goodman, Parking Garage Manager, Public Works/Parking Services Department. Contractor agrees that any information or documents, including digital GIS information, supplied by the Department pursuant to Article 3, below, shall be used by Contractor for this project only, and shall not be reused or reassigned for any other purpose without the written permission of the Department.

Article 2. Standard of Care Contractor shall be responsible for completion of the Services in a manner consistent with that degree of care and skill ordinarily exercised by members of the same profession currently practicing under similar circumstances (“Standard of Care”). The Department shall be the sole judge of the adequacy of Contractor’s work in meeting the Standard of Care; however, the Department shall not unreasonably withhold its approval as to the adequacy of Contractor’s performance. Upon notice to Contractor and by mutual agreement between the parties, Contractor will, without additional compensation, correct or replace any and all Services not meeting the Standard of Care.

Article 3. Responsibilities of the Department The Department shall provide all necessary information regarding requirements for the Services. The Department shall furnish such information as necessary for the orderly progress of the work, and Contractor shall be entitled to rely upon the accuracy and completeness of such information. The Department’s Project Manager shall act on its behalf with respect to this Agreement.

Article 4. Compensation The Department shall pay Contractor for all fees and expenses in an amount not to exceed Fourteen Thousand and Five Hundred dollars (\$14,500.00). Contractor shall submit an invoice to the Department upon the completion of the Services described in Article 1. The invoice shall be sent to: Jess Goodman, City of Bloomington Public Works, 401 N. Morton, Suite 120, Bloomington, Indiana 47404. Invoices may be sent via first class mail postage prepaid or via email. Payment will be remitted to Contractor within forty-five (45) days of receipt of invoice. Additional services not set forth in Article 1, or changes in the Services must be authorized in writing by the Department or its designated project coordinator prior to such work being performed, or expenses incurred. The Department shall not make payment for any unauthorized work or expenses.

Article 5. Appropriation of Funds Notwithstanding any other provision of this Agreement, if funds for the continued fulfillment of this Agreement by the Department are at any time not forthcoming or are insufficient, through failure of any entity, including the Department itself, to appropriate funds or otherwise, then the Department shall have the right to terminate this Agreement without penalty.

Article 6. Schedule Contractor shall perform the Services according to the following schedule: Contractor shall complete the Services required under this Agreement on or before December 31, 2024. The time limits established by this schedule shall not be exceeded, except for reasonable cause as mutually agreed to by all parties.

Article 7. Termination In the event of a party's substantial failure to perform in accordance with the terms of this Agreement, the other party shall have the right to terminate the Agreement upon written notice. The nonperforming party shall have fourteen (14) calendar days from the receipt of the termination notice to cure or to submit a plan for cure acceptable to the other party. Additionally, the Department may terminate or suspend performance of this Agreement at the Department's prerogative at any time upon written notice to Contractor. Contractor shall terminate or suspend performance of the Services on a schedule acceptable to the Department and the Department shall pay the Contractor for all the Services performed up to the date that written notice is received, plus reasonable termination or suspension expenses. Upon restart, an equitable adjustment shall be made to Contractor's compensation and the schedule of services. Upon termination or suspension of this Agreement, all finished or unfinished reports, drawings, collections of data and other documents generated by Contractor in connection with this Agreement shall become the property of the Department, as set forth in Article 9 herein.

Article 8. Identity of the Contractor Contractor acknowledges that one of the primary reasons for its selection by the Department to perform the Services is the qualifications and experience of Contractor. Contractor thus agrees that the Services to be performed pursuant to this Agreement shall be performed by Contractor. Contractor shall not subcontract any part of the Services without the prior written permission of the Department. The Department reserves the right to reject any of the Contractor's personnel or proposed outside professional sub-Contractors, and the Department reserves the right to request that acceptable replacement personnel be assigned to the project.

Article 9. Ownership of Documents and Intellectual Property All documents, drawings and specifications, including digital format files, prepared by Contractor and furnished to the Department as part of the Services shall become the property of the Department. Contractor shall retain its ownership rights in its design, drawing details, specifications, databases, computer software and other proprietary property. Intellectual property developed, utilized or modified in the performance of the Services shall remain the property of Contractor.

Article 10. Independent Contractor Status During the entire term of this Agreement, Contractor shall be an independent contractor, and in no event shall any of its personnel, agents or sub-contractors be construed to be, or represent themselves to be, employees of the Department. Contractor shall be solely responsible for the payment and reporting of all employee and employer taxes, including social security, unemployment, and any other federal, state, or local taxes required to be withheld from employees or payable on behalf of employees.

Article 11. Indemnification Contractor shall defend, indemnify, and hold harmless the City of Bloomington, the Department, and the officers, agents and employees of the City and the Department from any and all claims, demands, damages, costs, expenses or other liability arising out of the Agreement or occasioned by the reckless or negligent performance of any provision thereof, including, but not limited to, any reckless or negligent act or failure to act or any misconduct on the part of the Contractor or its agents or employees, or any independent contractors directly responsible to it (collectively "Claims").

Article 12. Insurance During the performance of any and all Services under this Agreement, Contractor shall maintain the following insurance in full force and effect: a) Comprehensive General Liability Insurance, with a minimum combined single limit of \$1,000,000 for each occurrence; 1,000,000 personal injury and advertising injury; \$2,000,000 products and completed operations aggregate; and \$2,000,000 general aggregate; b) Automobile Liability Insurance, with a minimum combined single limit of \$1,000,000 for each person and \$1,000,000 for each accident; c) Workers' Compensation Insurance in accordance with the statutory requirements of Title 22 of the Indiana Code; and d) Umbrella/Excess Liability with a required limit of \$1,000,000. In addition, if the Contractor receives payment from the City of Bloomington and/or has access to critical City data, Contractor shall also have the following: a) Cyber Attack and Cyber Extortion: computer attack limit (annual aggregate) of \$1,000,000; sublimit (per occurrence) for cyber extortion of \$100,000; and computer attack and cyber extortion deductible (per occurrence) of \$10,000; b) Network Security Liability: limit (annual aggregate) of \$1,000,000; and deductible (per occurrence) of \$10,000; c) Electronic Media Liability: limit (annual aggregate) of 1,000,000; and deductible (per occurrence) of \$10,000; and d) Fraudulent Impersonator Coverage: limit (annual aggregate) of \$250,000; and deductible (per occurrence) of \$5,000. All insurance policies shall be issued by an insurance company authorized to issue such insurance in the State of Indiana. The City of Bloomington, the Department, and the officers, employees and agents of each shall be named as insureds under the General Liability, Automobile, Worker's Compensation policies and Umbrella/Excess Liability policies, and such policies shall stipulate that the insurance will operate as primary insurance and that no other insurance of the City's will be called upon to contribute to a loss hereunder. Contractor shall provide evidence of each insurance policy to the Department prior to the commencement of work under this Agreement.

Article 13. Conflict of Interest Contractor declares that it has no present interest, nor shall it acquire any interest, direct or indirect, which would conflict with the performance of Services under this Agreement. Contractor agrees that no person having any such interest shall be employed in the performance of this Agreement.

Article 14. Waiver No failure of either party to enforce a term of this Agreement against the other shall be construed as a waiver of that term, nor shall it in any way affect the party's right to enforce that term. No waiver by any party of any term of this Agreement shall be considered to be a waiver of any other term or breach thereof.

Article 15. Severability The invalidity, illegality or unenforceability of any provision of this Agreement or the occurrence of any event rendering any portion or provision of this Agreement void shall in no way affect the validity or enforceability of any other portion or provision of this Agreement. Any void provision shall be deemed severed from this Agreement, and the balance of the Agreement shall be construed and enforced as if it did not contain the particular provision to be held void. The parties further agree to amend this Agreement to replace any stricken provision with a valid provision that comes as close as possible to the intent of the stricken provision. The provisions of this Article shall not prevent this entire Agreement from being void should a provision which is of the essence of this Agreement be determined void.

Article 16. Assignment Neither the Department nor the Contractor shall assign any rights or duties under this Agreement without the prior written consent of the other party. Unless otherwise stated in the written consent to an assignment, no assignment will release or discharge the assignor from any obligation under this Agreement.

Article 17. Third Party Rights Nothing in this Agreement shall be construed to give any rights or benefits to anyone other than the parties.

Article 18. Governing Law and Venue This Agreement shall be governed by the laws of the State of Indiana. Venue of any disputes arising under this Agreement shall be in the Monroe Circuit Court, Monroe County, Indiana.

Article 19. Non-Discrimination Contractor shall comply with City of Bloomington Ordinance 2.23.110 and all other federal, state and local laws and regulations governing non-discrimination in all regards, including, but not limited to, employment.

Article 20. Compliance with Laws In performing the Services under this Agreement, Contractor shall comply with any and all applicable federal, state and local statutes, ordinances, plans and regulations, including any and all regulations for protection of the environment. Where such statutes, ordinances, plans or regulations of any public authority having any jurisdiction over the project are in conflict, Contractor shall proceed using its best judgment only after attempting to resolve any such conflict between such governmental agencies, and shall notify the Department in a timely manner of the conflict, attempts of resolution, and planned course of action.

Article 21. E-Verify Contractor is required to enroll in and verify the work eligibility status of all newly-hired employees through the E-Verify program. (This is not required if the E-Verify program no longer exists). Contractor shall sign an affidavit, attached as Exhibit A, affirming that Contractor does not knowingly employ an unauthorized alien. Contractor shall require any subcontractors performing work under this contract to certify to the Contractor that, at the time of certification, the subcontractor does not knowingly employ or contract with an unauthorized alien and the subcontractor has enrolled in and is participating in the E-Verify program. Contractor shall maintain on file all subcontractors' certifications throughout the term of the contract with the City.

Article 22. Notices Any notice required by this Agreement shall be made in writing to the individuals/addresses specified below:

Department: City of Bloomington Public Works, Attn: Jess Goodman, 401 N. Morton, Suite 120, Bloomington, Indiana 47404.

Contractor: MultiCraft Fire, LLC, 320 W Country Club Dr., Bloomington Indiana 47403.

Nothing contained in this Article shall be construed to restrict the transmission of routine communications between representatives of the Department and Contractor.

Article 23. Integration and Modification This Agreement, including all Exhibits incorporated by reference, represents the entire and integrated agreement between the Department and the Contractor. It supersedes all prior and contemporaneous communications, representations and agreements, whether oral or written, relating to the subject matter of this Agreement. This Agreement may be modified only by a written amendment signed by both parties hereto.

Article 24. Non-Collusion Contractor is required to certify that it has not, nor has any other member, representative, or agent of Contractor, entered into any combination, collusion, or agreement with any person relative to the price to be offered by any person nor prevented any person from making an offer nor induced anyone to refrain from making an offer and that this offer is made without reference to any other offer. Contractor shall sign an affidavit, attached hereto as Exhibit B, affirming that Contractor has not engaged in any collusive conduct. Exhibit B is attached hereto and incorporated by reference as though fully set forth.

Article 25. Living Wage Ordinance Contractor is considered a "covered employer" under City Ordinance 2.28, otherwise known as the "Living Wage Ordinance," or "LWO," and is required to pay their covered employees at least a living wage. Currently, the living wage is \$15.75 per hour for covered employees, and

up to 15% of that amount, or \$2.36, may be in the form the covered employer's contribution to health insurance available to the covered employee.

Contractor shall execute the Living Wage Ordinance Affidavit, attached as Exhibit C; shall abide by the LWO by paying their employees a living wage; and shall post the Living Wage Poster, provided by the City Legal Department, in areas frequented by their covered employees.

CITY OF BLOOMINGTON

MultiCraft, LLC

Margie Rice Corporation Counsel

Chris Huskisson, Service Manager

CITY OF BLOOMINGTON PUBLIC WORKS

Adam Wason, Director

Kyla Cox Deckard, President, Board of Public Works

EXHIBIT B

STATE OF INDIANA)
) SS:
COUNTY OF _____)

NON-COLLUSION AFFIDAVIT

The undersigned offeror or agent, being duly sworn on oath, says that he has not, nor has any other member, representative, or agent of the firm, company, corporation or partnership represented by him, entered into any combination, collusion or agreement with any person relative to the price to be offered by any person nor to prevent any person from making an offer nor to induce anyone to refrain from making an offer and that this offer is made without reference to any other offer.

OATH AND AFFIRMATION

I affirm under the penalties of perjury that the foregoing facts and information are true and correct to the best of my knowledge and belief.

Dated this _____ day of _____, 2024.

MultiCraft, LLC

By: _____

STATE OF INDIANA)
) SS:
COUNTY OF _____)

Before me, a Notary Public in and for said County and State, personally appeared _____ and acknowledged the execution of the foregoing this _____ day of _____, 2024.

Notary Public's Signature My Commission Expires: _____

Printed Name of Notary Public County of Residence: _____

Commission Number: _____

EXHIBIT "C"

AFFIDAVIT THE LIVING WAGE ORDINANCE

The undersigned, being duly sworn, hereby affirms and says that:

1. The undersigned is the Click here to enter text. of Click here to enter text.
(job title) (company name)
2. The company named herein that employs the undersigned has contracted with or is seeking to contract with the City of Bloomington to provide services.
3. The undersigned hereby states that, to the best of their knowledge and belief, the company named herein is subject to Bloomington City Ordinance 2.28, otherwise known as the "Living Wage Ordinance."
4. The projected employment needs under the award include the following: Click here to enter text.
5. The projected net increase or decrease in jobs for covered employees by job title that will result from awarding the assistance: Click here to enter text.
6. The undersigned hereby affirms that the smallest hourly wage to be earned by each of their covered employees shall be at least the living wage.

I affirm under the penalties of perjury that the foregoing facts and information are true and correct to the best of my knowledge and belief.

Signature

Printed name

STATE OF INDIANA)
) SS:
COUNTY OF _____)

Before me, a Notary Public in and for said County and State, personally appeared _____
_____ and acknowledged the execution of the foregoing this _____ day of _____
_____, 2024.

My Commission Expires: _____

Notary Public

County of Residence: _____

Name Printed

Commission Number



Board of Public Works Claim Register

Invoice Date Range 08/31/24 - 09/13/24

Vendor	Invoice Description	Contract #	Payment Date	Invoice Amount
Fund 101 - General Fund (S0101)				
Department 01 - Animal Shelter				
Program 010000 - Main				
Account 43430 - Animal Adoption Fees				
Aubellani Diaz	01-refund adoption fee-canine-"Zelda"-8/26/24		09/13/2024	100.00
	Account 43430 - Animal Adoption Fees Totals Invoice Transactions 1			<u>\$100.00</u>
Account 52110 - Office Supplies				
6530 - Office Depot, INC	01-Tape, Post it notes		09/13/2024	31.79
6530 - Office Depot, INC	01-Folder labels, masking tape		09/13/2024	13.20
	Account 52110 - Office Supplies Totals Invoice Transactions 2			<u>\$44.99</u>
Account 52210 - Institutional Supplies				
4586 - Hill's Pet Nutrition Sales, INC	01-Dog, puppy, kitten & cat food	BC 2024-026	09/13/2024	308.05
4586 - Hill's Pet Nutrition Sales, INC	01-Dog, puppy, kitten & cat food	BC 2024-026	09/13/2024	174.20
4586 - Hill's Pet Nutrition Sales, INC	01-Prescription Veterinary Food	BC 2024-026	09/13/2024	275.47
4586 - Hill's Pet Nutrition Sales, INC	01-Prescription Veterinary Food	BC 2024-026	09/13/2024	45.44
4574 - John Deere Financial f.s.b. (Rural King)	01-litter-50 40lb bags pellet bedding		09/13/2024	249.50
4549 - Kroger Limited Partnership I	01-Tuna & Cat Milk		09/13/2024	26.61
4633 - Midwest Veterinary Supply, INC	01-Antibiotics, antivirals, antiparasitics, syringes		09/13/2024	877.44
4633 - Midwest Veterinary Supply, INC	01-vinyl exam gloves (L), ISO gowns, syringes		09/13/2024	214.01
4633 - Midwest Veterinary Supply, INC	01-Albuterol		09/13/2024	16.68
6530 - Office Depot, INC	01-duct tape, chair mat, paper, envelopes, laminating pouch		09/13/2024	132.88
4666 - Zoetis, INC	01-vaccines		09/13/2024	1,476.50
	Account 52210 - Institutional Supplies Totals Invoice Transactions 11			<u>\$3,796.78</u>



Board of Public Works Claim Register

Invoice Date Range 08/31/24 - 09/13/24

Account 52310 - Building Materials and Supplies

409 - Black Lumber Co. INC	01-22" HD Drawer Slide for desk repair-8/15/24	09/13/2024	12.99
409 - Black Lumber Co. INC	01-2 22" HD Drawer Slides for desk repair	09/13/2024	25.98
409 - Black Lumber Co. INC	01-22" HD Drawer Slide for desk repair-8/15/24	09/13/2024	12.99
Account 52310 - Building Materials and Supplies Totals Invoice Transactions 3			\$51.96

Account 52340 - Other Repairs and Maintenance

313 - Fastenal Company	01-Trash Liners	09/13/2024	104.88
313 - Fastenal Company	01-Laundry Detergent	09/13/2024	193.96
313 - Fastenal Company	01-Facial Tissues	09/13/2024	41.85
313 - Fastenal Company	01-sheet towel rolls	09/13/2024	49.63
Account 52340 - Other Repairs and Maintenance Totals Invoice Transactions 4			\$390.32

Account 52410 - Books

3560 - First Financial Bank / Credit Cards	01-Volunteer Administration Text Book-Canada conversion \$	09/13/2024	91.13
Account 52410 - Books Totals Invoice Transactions 1			\$91.13

Account 53130 - Medical

175 - Monroe County Humane Association, INC	01-Spay/Neuter Surgeries-8/6/24	09/13/2024	267.00
Account 53130 - Medical Totals Invoice Transactions 1			\$267.00

Account 53220 - Postage

3560 - First Financial Bank / Credit Cards	01-UPS-Bd of Animal Health-Specimen Shipping 08/20/24	09/13/2024	13.47
3560 - First Financial Bank / Credit Cards	01-UPS-Bd of Animal Health-Specimen Shipping 08/08/24	09/13/2024	13.72
3560 - First Financial Bank / Credit Cards	01-UPS-Bd of Animal Health-Specimen Shipping 08/15/24	09/13/2024	12.67
3560 - First Financial Bank / Credit Cards	01-UPS-Bd of Animal Health-Specimen Shipping 8/26/24	09/13/2024	13.47
3560 - First Financial Bank / Credit Cards	01-UPS-Bd of Animal Health-Specimen Shipping 08/13/24	09/13/2024	53.68
3560 - First Financial Bank / Credit Cards	01-UPS-Bd of Animal Health-Specimen Shipping 08/05/24	09/13/2024	30.68



Board of Public Works Claim Register

Invoice Date Range 08/31/24 - 09/13/24

3560 - First Financial Bank / Credit Cards

01-UPS Store-Board of Healthy Specimen Shipping-8/29/24	09/13/2024	14.82
Account 53220 - Postage Totals	Invoice Transactions 7	<hr/> \$152.51
Program 010000 - Main Totals	Invoice Transactions 30	<hr/> \$4,894.69

Program **010001 - Donations Over \$5K**

Account **52210 - Institutional Supplies**

4666 - Zoetis, INC

01-FelV test kits	09/13/2024	691.10
Account 52210 - Institutional Supplies Totals	Invoice Transactions 1	<hr/> \$691.10

Account **53130 - Medical**

6529 - BloomingPaws, LLC

01-Heartworm Treatment-Atticus	09/13/2024	102.35
--------------------------------	------------	--------

6529 - BloomingPaws, LLC

01-Heartworm Treatment-Atticus	09/13/2024	44.00
--------------------------------	------------	-------

3376 - Bloomington Pets Alive, INC

01-Spay/Neuter surgeries -8/1-8/15/24	09/13/2024	8,133.84
---------------------------------------	------------	----------

175 - Monroe County Humane Association, INC

01-Spay/Neuter Surgeries-8/6/24	09/13/2024	1,000.00
---------------------------------	------------	----------

54639 - Shake Veterinary Services, INC (Town & Country Vet

01-spay/neuter surgeries -8/6/24	09/13/2024	385.00
----------------------------------	------------	--------

Account 53130 - Medical Totals	Invoice Transactions 5	<hr/> \$9,665.19
---------------------------------------	------------------------	------------------

Program 010001 - Donations Over \$5K Totals	Invoice Transactions 6	<hr/> \$10,356.29
--	------------------------	-------------------

Department 01 - Animal Shelter Totals	Invoice Transactions 36	<hr/> \$15,250.98
--	-------------------------	-------------------

Department **02 - Public Works**

Program **020000 - Main**

Account **46060 - Other Violations**

Cassady Electric Inc

26-Customer overpaid, check for \$90 only owed \$60	09/13/2024	30.00
---	------------	-------

Nicholas Farid

26-Customer mailed check for \$60, only owed \$30	09/13/2024	30.00
---	------------	-------

Alexander David Jarvis

26-Refunding Late Fee	09/13/2024	30.00
-----------------------	------------	-------

Account 46060 - Other Violations Totals	Invoice Transactions 3	<hr/> \$90.00
--	------------------------	---------------

Account **53160 - Instruction**



Board of Public Works Claim Register

Invoice Date Range 08/31/24 - 09/13/24

3560 - First Financial Bank / Credit Cards

02-Refund APWA Workshop-Rosenberger-replaced Wason 09/13/2024 (300.00)

Account **53160 - Instruction** Totals Invoice Transactions 1 (\$300.00)

Account **53170 - Mgt. Fee, Consultants, and Workshops**

3735 - Bluestone Tree, INC.

02-Management of Storm Tree Debris & Grinding Services 09/13/2024 25,150.00

Account **53170 - Mgt. Fee, Consultants, and Workshops** Totals Invoice Transactions 1 \$25,150.00

Account **53230 - Travel**

3560 - First Financial Bank / Credit Cards

02-Delta-tickets APWA Conf-A Wason 09/13/2024 534.96

Account **53230 - Travel** Totals Invoice Transactions 1 \$534.96

Program **020000 - Main** Totals Invoice Transactions 6 \$25,474.96

Department **02 - Public Works** Totals Invoice Transactions 6 \$25,474.96

Department **03 - City Clerk**

Program **030000 - Main**

Account **53120 - Special Legal Services**

9460 - Chopra Criminal Defense dba Allison Chopra Law LLC

03-Clerk legal serv (Research/Document Drafting/Review)- 09/13/2024 275.00

7/23/24 Account **53120 - Special Legal Services** Totals Invoice Transactions 1 \$275.00

Account **53160 - Instruction**

259 - Indiana Association Of Cities & Towns (AIM)

03-2024 Aim Ideas Summit Conference-Clerk 09/13/2024 345.00

Account **53160 - Instruction** Totals Invoice Transactions 1 \$345.00

Program **030000 - Main** Totals Invoice Transactions 2 \$620.00

Department **03 - City Clerk** Totals Invoice Transactions 2 \$620.00

Department **04 - Economic & Sustainable Dev**

Program **040000 - Main**

Account **52110 - Office Supplies**

8541 - Amazon.com Sales, INC (Amazon.com Services LLC)

04-Extra Capacity Hanging File Folders 09/13/2024 38.78



Board of Public Works Claim Register

Invoice Date Range 08/31/24 - 09/13/24

Account 52110 - Office Supplies Totals			Invoice Transactions 1	<u>\$38.78</u>
Account 52420 - Other Supplies				
8541 - Amazon.com Sales, INC (Amazon.com Services LLC)	04-New Chair for New Employee		09/13/2024	259.50
3560 - First Financial Bank / Credit Cards	04-Form Approvals - Google Add on 100 Request 3 months		09/13/2024	30.00
3560 - First Financial Bank / Credit Cards	04-Lowes - Airbeam Sensor Cables, cable ties-8/3/24		09/13/2024	54.10
293 - J&S Locksmith Shop, INC	04-Electric Mower and Batteries for Parks		09/13/2024	1,053.56
53442 - Paragon Micro, INC	04-New Laptop for New Employee		09/13/2024	2,689.98
Account 52420 - Other Supplies Totals			Invoice Transactions 5	<u>\$4,087.14</u>
Account 53160 - Instruction				
3560 - First Financial Bank / Credit Cards	04-Butter Fine Art Festival Registration - Holly Warren		09/13/2024	44.52
3560 - First Financial Bank / Credit Cards	04-Butter Fine Art Festival Registration - Chaz Mottinger		09/13/2024	44.52
Account 53160 - Instruction Totals			Invoice Transactions 2	<u>\$89.04</u>
Account 53910 - Dues and Subscriptions				
8845 - ClimateNav, INC	04-Full Annual Fee for Second Half of FY24		09/13/2024	30,000.00
3560 - First Financial Bank / Credit Cards	04-AirTable Subscription Update 07/25/24-02/21/25		09/13/2024	128.41
3560 - First Financial Bank / Credit Cards	04-MailChimp Monthly Subscription - Aug 2024		09/13/2024	45.00
7082 - ICLEI-Local Governments for Sustainability USA INC	04-Annual Membership - 10/1/2024-9/30/2025		09/13/2024	1,200.00
Account 53910 - Dues and Subscriptions Totals			Invoice Transactions 4	<u>\$31,373.41</u>
Account 53960 - Grants				
4397 - A & D Cycling Enterprises, LLC (Revolution Bike)	04-E-Bike Voucher Program Grant (3)-locks/helmets-08/26/24		09/13/2024	4,934.83
9427 - Jessica Ann MacLean	04-BAC 2024 Arts Project Grant		09/13/2024	1,500.00
9401 - Debra Lynn Ponella	04-2024 BAC Arts Project Grant - Debbi Ponella		09/13/2024	1,500.00
Account 53960 - Grants Totals			Invoice Transactions 3	<u>\$7,934.83</u>
Account 53990 - Other Services and Charges				



Board of Public Works Claim Register

Invoice Date Range 08/31/24 - 09/13/24

321 - Harrell Fish, INC (HFI)

04-Analysis of Roof Leak at WFHB-7/16/24 09/13/2024 192.50

9416 - Luke Judd

04-Public Art Repair-Prisma Maintenance 09/13/2024 550.00

Account **53990 - Other Services and Charges** Totals Invoice Transactions 2 \$742.50

Program **040000 - Main** Totals Invoice Transactions 17 \$44,265.70

Program **04CRED - ESD CRED**

Account **53960 - Grants**

5695 - 1818 Apparel Co., INC (dba Freethink AppareI)

04-Go Bloomington Bike Stickers (200) 09/13/2024 120.00

5695 - 1818 Apparel Co., INC (dba Freethink AppareI)

04-240 Go Hoosiers T-Shirts for Go Bloomington Promo 09/13/2024 2,606.40

3404 - J.R. Watkins & Family, INC (Signs Now-Abacadabra)

04-Happy 2nd Anniversary Go Bloomington Sign 09/13/2024 40.00

Account **53960 - Grants** Totals Invoice Transactions 3 \$2,766.40

Program **04CRED - ESD CRED** Totals Invoice Transactions 3 \$2,766.40

Program **04TECH - Trades Tech Center**

Account **53990 - Other Services and Charges**

9150 - Multicraft Fire LLC

04-Trades District Tech Ctr-Fire Protection-Pay App 6 09/13/2024 4,987.50

9150 - Multicraft Fire LLC

04-Trades District Tech Ctr-Fire Protection-Pay App 5 09/13/2024 8,312.50

Account **53990 - Other Services and Charges** Totals Invoice Transactions 2 \$13,300.00

Program **04TECH - Trades Tech Center** Totals Invoice Transactions 2 \$13,300.00

Department **04 - Economic & Sustainable Dev** Totals Invoice Transactions 22 \$60,332.10

Department **05 - Common Council**

Program **050000 - Main**

Account **52110 - Office Supplies**

6530 - Office Depot, INC

05 - 2 easels 09/13/2024 138.42

6530 - Office Depot, INC

05 - Name Badges-2 100 packs 09/13/2024 7.08

Account **52110 - Office Supplies** Totals Invoice Transactions 2 \$145.50



Board of Public Works Claim Register

Invoice Date Range 08/31/24 - 09/13/24

Program **050000 - Main** Totals Invoice Transactions 2 \$145.50

Department **05 - Common Council** Totals Invoice Transactions 2 \$145.50

Department **06 - Controller's Office**

Program **060000 - Main**

Account **52420 - Other Supplies**

8541 - Amazon.com Sales, INC (Amazon.com Services LLC)	06- Under desk Keyboard tray - A. Silkworth	09/13/2024	49.99
5103 - Staples Contract & Commercial, INC	06-Office Chair for J Long	09/13/2024	69.99
5103 - Staples Contract & Commercial, INC	06-HP 89Y Black Extra High-Yield Toner - AP/AR printer	09/13/2024	360.37

Account **52420 - Other Supplies** Totals Invoice Transactions 3 \$480.35

Account **53170 - Mgt. Fee, Consultants, and Workshops**

50587 - Barnes & Thornburg LLP	06-Legal services for Sudbury/Summit Housing Dev-June 2024	09/13/2024	3,136.50
--------------------------------	--	------------	----------

Account **53170 - Mgt. Fee, Consultants, and Workshops** Totals Invoice Transactions 1 \$3,136.50

Program **060000 - Main** Totals Invoice Transactions 4 \$3,616.85

Department **06 - Controller's Office** Totals Invoice Transactions 4 \$3,616.85

Department **07 - Engineering**

Program **070000 - Main**

Account **52110 - Office Supplies**

5103 - Staples Contract & Commercial, INC	07-Highlighters, Permanent Markers, Document Holder, Dymo Labels	09/13/2024	51.85
---	--	------------	-------

Account **52110 - Office Supplies** Totals Invoice Transactions 1 \$51.85

Account **53910 - Dues and Subscriptions**

3560 - First Financial Bank / Credit Cards	07-doxpop Subscription Access to Public Records 8/13/24	09/13/2024	44.40
--	---	------------	-------

Account **53910 - Dues and Subscriptions** Totals Invoice Transactions 1 \$44.40

Account **53990 - Other Services and Charges**

399 - American Structurepoint, INC	07-On-Call Signal Traffic Eng Services 07/01/24-07/31/24 BC 2022-056	09/13/2024	1,218.14
------------------------------------	--	------------	----------



Board of Public Works Claim Register

Invoice Date Range 08/31/24 - 09/13/24

11272 - Patriot Engineering And Enviromental, INC

07 - Geotechnical Services 07/31/24	BC 2023-107	09/13/2024	334.50
Account 53990 - Other Services and Charges Totals		Invoice Transactions 2	<hr/> \$1,552.64
Program 070000 - Main Totals		Invoice Transactions 4	<hr/> \$1,648.89
Department 07 - Engineering Totals		Invoice Transactions 4	<hr/> \$1,648.89

Department **09 - CFRD**

Program **090000 - Main**

Account **52110 - Office Supplies**

6530 - Office Depot, INC	09-Office Supplies-Chair Mats and Address Labels	09/13/2024	128.04
6530 - Office Depot, INC	09-Office Supplies-2 cases 11 x 17 paper, Laminating Pouches	09/13/2024	114.29
Account 52110 - Office Supplies Totals		Invoice Transactions 2	<hr/> \$242.33

Account **52420 - Other Supplies**

8541 - Amazon.com Sales, INC (Amazon.com Services LLC)	09-CFRD Events & Programs-24 Pcks of Popcorn, 12 Doc Holders	09/13/2024	65.98
4549 - Kroger Limited Partnership I	09-After Hours Ambassador Supplies-Water for Unhoused Folks	09/13/2024	35.94
4549 - Kroger Limited Partnership I	09-Snacks and Drinks for NARCAN Training Participants Aug 2024	09/13/2024	60.02
Account 52420 - Other Supplies Totals		Invoice Transactions 3	<hr/> \$161.94

Account **53170 - Mgt. Fee, Consultants, and Workshops**

4123 - Central Indiana Interpreting Service	09-Captioning Implementation and Rollout-CFRD Portion-8/15/24	09/13/2024	65.00
Account 53170 - Mgt. Fee, Consultants, and Workshops Totals		Invoice Transactions 1	<hr/> \$65.00

Account **53310 - Printing**

3560 - First Financial Bank / Credit Cards	09-UPrinting-Stickers for Human Rights Commission Outreach 2024	09/13/2024	97.47
Account 53310 - Printing Totals		Invoice Transactions 1	<hr/> \$97.47

Account **53910 - Dues and Subscriptions**

3560 - First Financial Bank / Credit Cards	09-Constant Contact Monthly Subscription Payment-August 2024	09/13/2024	145.00
Account 53910 - Dues and Subscriptions Totals		Invoice Transactions 1	<hr/> \$145.00



Board of Public Works Claim Register

Invoice Date Range 08/31/24 - 09/13/24

Account **53990 - Other Services and Charges**

3560 - First Financial Bank / Credit Cards

09-Bloomington Pride Ltd.-Human Rights Commission	09/13/2024	175.00
Table Fee		
Account 53990 - Other Services and Charges Totals	Invoice Transactions 1	<u>\$175.00</u>
Program 090000 - Main Totals	Invoice Transactions 9	<u>\$886.74</u>
Department 09 - CFRD Totals	Invoice Transactions 9	<u>\$886.74</u>

Department **10 - Legal**

Program **100000 - Main**

Account **52420 - Other Supplies**

3560 - First Financial Bank / Credit Cards

10-AIA Contract Documents - CMC	09/13/2024	109.99
53442 - Paragon Micro, INC	10-Adobe Pro Licenses - Wheeler, Holmes, Allen - S5165768	1,469.97
	Account 52420 - Other Supplies Totals	<u>\$1,579.96</u>
	Invoice Transactions 2	

Account **53120 - Special Legal Services**

50587 - Barnes & Thornburg LLP

10-ARPA Compliance and Reporting Advice-June 2024	09/13/2024	788.50
	Account 53120 - Special Legal Services Totals	<u>\$788.50</u>
	Invoice Transactions 1	

Account **53160 - Instruction**

3560 - First Financial Bank / Credit Cards

10- ICLEF CLE - Conference Fee-A. Holmes-9/12-9/13	09/13/2024	495.00
--	------------	--------

259 - Indiana Association Of Cities & Towns (AIM)

10-AIM Ideas Summit - Rice	09/13/2024	345.00
----------------------------	------------	--------

Account 53160 - Instruction Totals	Invoice Transactions 2	<u>\$840.00</u>
Program 100000 - Main Totals	Invoice Transactions 5	<u>\$3,208.46</u>
Department 10 - Legal Totals	Invoice Transactions 5	<u>\$3,208.46</u>

Department **11 - Mayor's Office**

Program **110000 - Main**

Account **43380 - Other Services**

4123 - Central Indiana Interpreting Service

11- Interpreting Services split 50/50 with CFRD	09/13/2024	65.00
---	------------	-------



Board of Public Works Claim Register

Invoice Date Range 08/31/24 - 09/13/24

7149 - Namify, LLC	11-Name Tag for Sheri Allen-HR	09/13/2024	16.65
7149 - Namify, LLC	11-Name Tag Noah Sandweiss-HAND	09/13/2024	38.50
7149 - Namify, LLC	11-Name Tags-OOTM Staff & Street-D. Stephens	09/13/2024	89.20
7149 - Namify, LLC	11-Name Tag for Robyn Peffinger-ACC	09/13/2024	27.15
7149 - Namify, LLC	11-Name Tag for Felicia Hershman-HAND	09/13/2024	16.65
7149 - Namify, LLC	11-Name Tag for Eliza Brader-ITS	09/13/2024	25.40
7149 - Namify, LLC	11-Name Tag for Courtney Daily-City Council	09/13/2024	38.50
7149 - Namify, LLC	11-Name Tags for City Staff-HR/P&R/ENG/ESD	09/13/2024	60.59
7149 - Namify, LLC	11-Name Tags for City Staff-Radewan & Swift	09/13/2024	48.49
7149 - Namify, LLC	11-Name Tag for Rachel Sargent	09/13/2024	27.15
7149 - Namify, LLC	11-Name Tags for CFRD Staff (6)	09/13/2024	79.85
Account 43380 - Other Services Totals Invoice Transactions 12			\$533.13
Account 53910 - Dues and Subscriptions			
3560 - First Financial Bank / Credit Cards	11-Sendinblue Monthly Sub 7/30 to 08/30 for Brevo fka Sendinblue	09/13/2024	181.00
3560 - First Financial Bank / Credit Cards	11-Lucid Software-Monthly LucidChart Sub 08/06-09/06/24	09/13/2024	9.95
158 - United States Conference of Mayors	11-2025 Membership	09/13/2024	5,796.00
Account 53910 - Dues and Subscriptions Totals Invoice Transactions 3			\$5,986.95
Account 53960 - Grants			
199 - Monroe County Government	11-2024 Recovery Summit Partner Package	09/13/2024	10,000.00
Account 53960 - Grants Totals Invoice Transactions 1			\$10,000.00
Program 110000 - Main Totals Invoice Transactions 16			\$16,520.08
Department 11 - Mayor's Office Totals Invoice Transactions 16			\$16,520.08

Department **12 - Human Resources**

Program **120000 - Main**



Board of Public Works Claim Register

Invoice Date Range 08/31/24 - 09/13/24

Account 52110 - Office Supplies

6530 - Office Depot, INC	12-printer toner 26X black high yield Item number CF226X	09/13/2024	155.17
Account 52110 - Office Supplies Totals Invoice Transactions 1			\$155.17

Account 53160 - Instruction

5444 - Tyler Technologies, INC	12-Open Enrollment Training (3)-7/29/24	09/13/2024	525.00
Account 53160 - Instruction Totals Invoice Transactions 1			\$525.00

Account 53230 - Travel

3560 - First Financial Bank / Credit Cards	12-T Williams JW Marriott Hotel Room Credit sales tax	09/13/2024	(54.23)
3560 - First Financial Bank / Credit Cards	12-K Scales French Lick Hotel Credit-sales tax chgd 7/17	09/13/2024	(46.54)
3560 - First Financial Bank / Credit Cards	12-S Pechac French Lick Hotel Credit-sales tax chgd 7/17	09/13/2024	(46.54)
3560 - First Financial Bank / Credit Cards	12-S Johnson Registration for KSU Career Fair	09/13/2024	205.90
3560 - First Financial Bank / Credit Cards	12-S Allen JW Marriott Valet Parking	09/13/2024	136.00
3560 - First Financial Bank / Credit Cards	12-H Kanyi JW Marriott Parking-Indy-8/11-8/14	09/13/2024	165.00
9402 - Thomas Williams	12-per diem-Healthcare Summit-Indy-6/10-6/11/24	09/13/2024	41.00
9402 - Thomas Williams	12-pkg reimb-AIM Members Forum-Indy-7/31/24	09/13/2024	35.95
9402 - Thomas Williams	12-pkg reimb-Everside/Marathon Forum-Indy-8/7/24	09/13/2024	43.25
Account 53230 - Travel Totals Invoice Transactions 9			\$479.79
Program 120000 - Main Totals Invoice Transactions 11			\$1,159.96
Department 12 - Human Resources Totals Invoice Transactions 11			\$1,159.96

Department 13 - Planning

Program 130000 - Main

Account 53910 - Dues and Subscriptions

3560 - First Financial Bank / Credit Cards	13- TransCAD License Renewal P Martin-08/31/24-08/31/25	09/13/2024	1,800.00
Account 53910 - Dues and Subscriptions Totals Invoice Transactions 1			\$1,800.00



Board of Public Works Claim Register

Invoice Date Range 08/31/24 - 09/13/24

Account **53990 - Other Services and Charges**

6235 - Toole Design Group, LLC	13-Corridor Study-College & Walnut-45/46 Bypass to Allen- BC 2022-086	09/13/2024	5,638.40
	7/26/24		
6235 - Toole Design Group, LLC	13- Safe Streets and Roads for All Action Plan thru BC 2023-036	09/13/2024	12,070.48
	07/26/24		
Account 53990 - Other Services and Charges Totals Invoice Transactions 2			<hr/> \$17,708.88
Program 130000 - Main Totals Invoice Transactions 3			<hr/> \$19,508.88

Program **132000 - MPO**

Account **53160 - Instruction**

3560 - First Financial Bank / Credit Cards	13-MPO INSight Conference Registration for Pat Martin	09/13/2024	137.50
Account 53160 - Instruction Totals Invoice Transactions 1			<hr/> \$137.50

Account **53990 - Other Services and Charges**

3414 - Burgess & Niple, INC	13- BMCMPO 2050 Transportation Plan 07/01/24-07/31/24 BC 2023-082	09/13/2024	9,000.00
Account 53990 - Other Services and Charges Totals Invoice Transactions 1			<hr/> \$9,000.00
Program 132000 - MPO Totals Invoice Transactions 2			<hr/> \$9,137.50
Department 13 - Planning Totals Invoice Transactions 5			<hr/> \$28,646.38

Department **19 - Facilities Maintenance**

Program **190000 - Main**

Account **52210 - Institutional Supplies**

8541 - Amazon.com Sales, INC (Amazon.com Services LLC)	19 - water filters for City Hall drinking fountains	09/13/2024	208.38
Account 52210 - Institutional Supplies Totals Invoice Transactions 1			<hr/> \$208.38

Account **52310 - Building Materials and Supplies**

413 - Bloomington Paint & Wallpaper Co	19 - paint for OOTM Comms office	09/13/2024	238.10
3560 - First Financial Bank / Credit Cards	19-Harbor Freight-2 propane weed killer torches-Brighten B-Town	09/13/2024	80.97
293 - J&S Locksmith Shop, INC	19- (5) Trimmer line for Facilities	09/13/2024	60.45
8658 - Kleindorfer's Hardware LLC	19- pikstiks, screws, paint stopnuts for Facilities	09/13/2024	178.97



Board of Public Works Claim Register

Invoice Date Range 08/31/24 - 09/13/24

8658 - Kleindorfer's Hardware LLC	19- (2) Notched trowel, utility knife, roofing blades		09/13/2024	23.66
8658 - Kleindorfer's Hardware LLC	19- paint roller screen, acetone, hole saw, roller - Facilities		09/13/2024	108.97
Account 52310 - Building Materials and Supplies Totals Invoice Transactions 6				<u>\$691.12</u>
Account 52430 - Uniforms and Tools				
4574 - John Deere Financial f.s.b. (Rural King)	19-Water & toilet paper For Brighten B-Town		09/13/2024	29.54
19171 - Vestis Group, INC (FKA Aramark)	19- Uniform pants for R. Flake -8/15/24		09/13/2024	14.20
19171 - Vestis Group, INC (FKA Aramark)	19- Uniform pants for R. Flake-8/22/24		09/13/2024	14.20
Account 52430 - Uniforms and Tools Totals Invoice Transactions 3				<u>\$57.94</u>
Account 53140 - Exterminator Services				
51538 - Economy Termite & Pest Control, INC	19-monthly pest control-Counsel Office- 8/16/24	BC 2023-070	09/13/2024	75.00
Account 53140 - Exterminator Services Totals Invoice Transactions 1				<u>\$75.00</u>
Account 53170 - Mgt. Fee, Consultants, and Workshops				
12604 - Howard D Bruce (Tabor/Bruce Architecture & Design, INC)	19-SA design drawings for City Hall renovations-8/20/24	BC 2023-111	09/13/2024	4,791.50
12604 - Howard D Bruce (Tabor/Bruce Architecture & Design, INC)	19-SA design drawings-HR renovation-8/20/24	BC 2023-111	09/13/2024	4,512.00
12604 - Howard D Bruce (Tabor/Bruce Architecture & Design, INC)	19-SA design drawings-City Hall break room remodel-8/20/24	BC 2023-111	09/13/2024	3,759.00
Account 53170 - Mgt. Fee, Consultants, and Workshops Totals Invoice Transactions 3				<u>\$13,062.50</u>
Account 53610 - Building Repairs				
321 - Harrell Fish, INC (HFI)	19-SA City Hall repair council chambers chiller-7/9/24	BC 2023-074	09/13/2024	287.50
321 - Harrell Fish, INC (HFI)	19-SA City Hall repair cooling unit2.12 in OOTC-7/19/24	BC 2023-074	09/13/2024	287.50
321 - Harrell Fish, INC (HFI)	19 - SA City Hall repair condensate leak in CFRD-7/18/24	BC 2023-074	09/13/2024	798.29
321 - Harrell Fish, INC (HFI)	19-SA City Hall investigate leak in water system-8/9/24	BC 2023-074	09/13/2024	525.00
321 - Harrell Fish, INC (HFI)	19-SA City Hall install thermostat for unit 2-06-7/30/24	BC 2023-074	09/13/2024	532.30
321 - Harrell Fish, INC (HFI)	19-SA City Hall repair first floor communication issues-6/28/24	BC 2023-074	09/13/2024	190.00
321 - Harrell Fish, INC (HFI)	19-SA City Hall repair noise & motor in cooling tower West side	BC 2023-074	09/13/2024	17,311.32



Board of Public Works Claim Register

Invoice Date Range 08/31/24 - 09/13/24

Account 53610 - Building Repairs Totals			Invoice Transactions 7	<u>\$19,931.91</u>
Program 190000 - Main Totals			Invoice Transactions 21	<u>\$34,026.85</u>
Department 19 - Facilities Maintenance Totals			Invoice Transactions 21	<u>\$34,026.85</u>
Department 28 - ITS				
Program 280000 - Main				
Account 52420 - Other Supplies				
6530 - Office Depot, INC	28-(6) rolls plotter paper		09/13/2024	533.34
Account 52420 - Other Supplies Totals			Invoice Transactions 1	<u>\$533.34</u>
Account 53160 - Instruction				
8541 - Amazon.com Sales, INC (Amazon.com Services LLC)	28- Two ITS Books		09/13/2024	60.05
Account 53160 - Instruction Totals			Invoice Transactions 1	<u>\$60.05</u>
Account 53910 - Dues and Subscriptions				
3560 - First Financial Bank / Credit Cards	28-Squarespace-Website & App Domains helinabloomingtonmonre.org		09/13/2024	12.00
3560 - First Financial Bank / Credit Cards	28-AWS Website & Application APIs 07/01/24-07/31/24		09/13/2024	1.00
3560 - First Financial Bank / Credit Cards	28- Zoom - Subscriptions & Storage Fees 08/04/24		09/13/2024	89.95
3560 - First Financial Bank / Credit Cards	28- Zoom - Subscriptions & Storage Fees 08/20/24-09/19/24		09/13/2024	430.00
3560 - First Financial Bank / Credit Cards	28-Google - Website & Application APIs & Domains 7/1/24-7/31/24		09/13/2024	367.18
3560 - First Financial Bank / Credit Cards	28-Submittable - Application Sub Software 08/27/24-09/27/24		09/13/2024	119.00
7344 - Periodic INC	28- Online Booking Subscriptions July 2024 Overages		09/13/2024	140.50
8441 - Promevo Holdings, INC (Promevo, LLC)	28-Google Enterprise & gPanel Renewal & Archive 8/6/24-8/6/25		09/13/2024	276.00
Account 53910 - Dues and Subscriptions Totals			Invoice Transactions 8	<u>\$1,435.63</u>
Program 280000 - Main Totals			Invoice Transactions 10	<u>\$2,029.02</u>
Department 28 - ITS Totals			Invoice Transactions 10	<u>\$2,029.02</u>
Fund 101 - General Fund (S0101) Totals			Invoice Transactions 153	<u>\$193,566.77</u>



Board of Public Works Claim Register

Invoice Date Range 08/31/24 - 09/13/24

Fund **103 - Restricted Donations(ord 05-17)**

Department **06 - Controller's Office**

Program **400101 - Animal Medical Services**

Account **53130 - Medical**

6529 - BloomingPaws, LLC	01-Exam & Diagnostics-Stewart	09/13/2024	230.68
6529 - BloomingPaws, LLC	01-X-rays-Nuzzle	09/13/2024	120.00
6529 - BloomingPaws, LLC	01-Vet exam-Face	09/13/2024	52.00
175 - Monroe County Humane Association, INC	01-X-Rays	09/13/2024	50.00
Account 53130 - Medical Totals Invoice Transactions 4			\$452.68
Program 400101 - Animal Medical Services Totals Invoice Transactions 4			\$452.68

Program **400102 - Animal Supplies**

Account **52210 - Institutional Supplies**

3278 - Boehringer Ingelheim Animal Health (Merial, INC)	01-Insulin	09/13/2024	175.52
4633 - Midwest Veterinary Supply, INC	01-Antibiotics, supportive therapies, vinyl exam gloves (M)	09/13/2024	240.15
4633 - Midwest Veterinary Supply, INC	01-Gabapentin, needles, bandages	09/13/2024	29.01
4633 - Midwest Veterinary Supply, INC	01-Antibiotics, Incurin, bottles	09/13/2024	526.08
4633 - Midwest Veterinary Supply, INC	01-Syringes	09/13/2024	150.69
Account 52210 - Institutional Supplies Totals Invoice Transactions 5			\$1,121.45
Program 400102 - Animal Supplies Totals Invoice Transactions 5			\$1,121.45
Department 06 - Controller's Office Totals Invoice Transactions 9			\$1,574.13
Fund 103 - Restricted Donations(ord 05-17) Totals Invoice Transactions 9			\$1,574.13

Fund **153 - LIT – Economic Development**

Department **04 - Economic & Sustainable Dev**

Program **040000 - Main**



Board of Public Works Claim Register

Invoice Date Range 08/31/24 - 09/13/24

Account **53960 - Grants**

4505 - Bicycle Garage, INC	04-E-Bike Voucher Program Grant Agreement 08/16/24	09/13/2024	414.99
4505 - Bicycle Garage, INC	04-Cruiser Go Stop Thru US M Galactic Black, lock key	09/13/2024	1,235.08
409 - Black Lumber Co. INC	04-Makita 18V Pole Hedge Trimmer for Parks	09/13/2024	279.99
293 - J&S Locksmith Shop, INC	04-Electric Mower and Batteries for Parks	09/13/2024	2,256.38
8135 - John Jones Chevrolet Buick Cadillac of Salem INC	04: 2024 Chevy Equinox EV VIN 3GN7DSRP1RS254814	09/13/2024	44,075.50

Account **53960 - Grants** Totals Invoice Transactions 5 \$48,261.94

Program **040000 - Main** Totals Invoice Transactions 5 \$48,261.94

Department **04 - Economic & Sustainable Dev** Totals Invoice Transactions 5 \$48,261.94

Fund **153 - LIT – Economic Development** Totals Invoice Transactions 5 \$48,261.94

Fund **176 - ARPA Local Fiscal Recvry (S9512)**

Department **09 - CFRD**

Program **G21005 - ARPA COVID Local Fiscal Recovery**

Account **53990 - Other Services and Charges**

9411 - BlueDAG LLC	09-BlueDag Software for CCA Accessibility Surveying	09/13/2024	4,900.00
--------------------	---	------------	----------

Account **53990 - Other Services and Charges** Totals Invoice Transactions 1 \$4,900.00

Program **G21005 - ARPA COVID Local Fiscal Recovery** Totals Invoice Transactions 1 \$4,900.00

Department **09 - CFRD** Totals Invoice Transactions 1 \$4,900.00

Department **28 - ITS**

Program **G21005 - ARPA COVID Local Fiscal Recovery**

Account **54420 - Purchase of Equipment**

9122 - Governmentjobs.com, INC (NEOGOV)	28-HR Applicant tracking software & related serv-8/24'-8/25'	09/13/2024	48,960.00
---	--	------------	-----------

Account **54420 - Purchase of Equipment** Totals Invoice Transactions 1 \$48,960.00

Program **G21005 - ARPA COVID Local Fiscal Recovery** Totals Invoice Transactions 1 \$48,960.00



Board of Public Works Claim Register

Invoice Date Range 08/31/24 - 09/13/24

		Department 28 - ITS Totals	Invoice Transactions 1	\$48,960.00
		Fund 176 - ARPA Local Fiscal Recvry (S9512) Totals	Invoice Transactions 2	\$53,860.00
Fund 249 - Grants Non Approp				
Department 04 - Economic & Sustainable Dev				
Program G23001 - 2023 Duke Energy Arts				
Account 53960 - Grants				
7545 - Big Boy's Moving LLC (BBM Services)	04-Priming of Duke Energy Substation Mural		09/13/2024	1,500.00
8528 - Caleb Olin Meredith Poer	04-Mural Rendering 08/27/24		09/13/2024	1,500.00
8887 - PowerWasher Plus LLC	04-Duke Substation Pre-Mural Cleaning W 11th St & N. Rogers St		09/13/2024	400.00
		Account 53960 - Grants Totals	Invoice Transactions 3	\$3,400.00
		Program G23001 - 2023 Duke Energy Arts Totals	Invoice Transactions 3	\$3,400.00
		Department 04 - Economic & Sustainable Dev Totals	Invoice Transactions 3	\$3,400.00
		Fund 249 - Grants Non Approp Totals	Invoice Transactions 3	\$3,400.00
Fund 312 - Community Services				
Department 09 - CFRD				
Program 090004 - Com Serv- Accessibility				
Account 53990 - Other Services and Charges				
9405 - Brightside Investments & Holdings (Brightside Cafe)	09-50 Gluten Free Cookies for ADA Anniversary Celebration 2024		09/13/2024	50.00
		Account 53990 - Other Services and Charges Totals	Invoice Transactions 1	\$50.00
		Program 090004 - Com Serv- Accessibility Totals	Invoice Transactions 1	\$50.00
Program 090014 - Latino Programs				
Account 52420 - Other Supplies				
8541 - Amazon.com Sales, INC (Amazon.com Services LLC)	9-Fiesta del Otono Supplies-Stickers, Pencils, Keychains		09/13/2024	112.93
		Account 52420 - Other Supplies Totals	Invoice Transactions 1	\$112.93



Board of Public Works Claim Register

Invoice Date Range 08/31/24 - 09/13/24

Program **090016 - Com Serv - Safe & Civil**

Account **52420 - Other Supplies**

3560 - First Financial Bank / Credit Cards

09-Black y Brown Arts Festival 2024-Branded Decals 09/13/2024 175.00

Account **52420 - Other Supplies** Totals Invoice Transactions 1 \$175.00

Account **53990 - Other Services and Charges**

3560 - First Financial Bank / Credit Cards

09-Safe & Civil City Jotform-8/25-9/25-Acct 1-moss 09/13/2024 19.00

3560 - First Financial Bank / Credit Cards

09-Safe & Civil City Jotform-8/29-9/29-Acct 2-safeandcivil 09/13/2024 19.00

Account **53990 - Other Services and Charges** Totals Invoice Transactions 2 \$38.00

Program **090016 - Com Serv - Safe & Civil** Totals Invoice Transactions 3 \$213.00

Department **09 - CFRD** Totals Invoice Transactions 5 \$375.93

Fund **312 - Community Services** Totals Invoice Transactions 5 \$375.93

Fund **401 - Non-Reverting Telecom (S1146)**

Department **25 - Telecommunications**

Program **256000 - Services**

Account **53150 - Communications Contract**

203 - INDIANA UNIVERSITY

28-Fire Station Dark Fiber Service 08/01/24-08/31/24 09/13/2024 85.00

Account **53150 - Communications Contract** Totals Invoice Transactions 1 \$85.00

Program **256000 - Services** Totals Invoice Transactions 1 \$85.00

Department **25 - Telecommunications** Totals Invoice Transactions 1 \$85.00

Fund **401 - Non-Reverting Telecom (S1146)** Totals Invoice Transactions 1 \$85.00

Fund **450 - Local Road and Street(S0706)**

Department **20 - Street**

Program **200000 - Main**



Board of Public Works Claim Register

Invoice Date Range 08/31/24 - 09/13/24

Account **53520 - Street Lights / Traffic Signals**

223 - Duke Energy	02-Traffic Signals-06/28/24-08/02/24	09/05/2024	799.08
223 - Duke Energy	02-Street Light (Misc Lights)-07/18/24-08/21/24	09/05/2024	83.81
Account 53520 - Street Lights / Traffic Signals Totals Invoice Transactions 2			<hr/> \$882.89
Program 200000 - Main Totals Invoice Transactions 2			<hr/> \$882.89
Department 20 - Street Totals Invoice Transactions 2			<hr/> \$882.89
Fund 450 - Local Road and Street(S0706) Totals Invoice Transactions 2			<hr/> \$882.89

Fund **451 - Motor Vehicle Highway(S0708)**

Department **20 - Street**

Program **200000 - Main**

Account **52110 - Office Supplies**

8541 - Amazon.com Sales, INC (Amazon.com Services LLC)	20-Office Supplies for Admin Office (note & mouse pads)	09/13/2024	37.04
Account 52110 - Office Supplies Totals Invoice Transactions 1			<hr/> \$37.04

Account **52210 - Institutional Supplies**

313 - Fastenal Company	20-safety glasses, gloves, paint, vests	09/13/2024	119.49
Account 52210 - Institutional Supplies Totals Invoice Transactions 1			<hr/> \$119.49

Account **52420 - Other Supplies**

8541 - Amazon.com Sales, INC (Amazon.com Services LLC)	20-Credit Return for Logitech Crayon Pencils for Ipads	09/13/2024	(139.90)
409 - Black Lumber Co. INC	20-PB Blaster Penetrant-signal cabinets	09/13/2024	4.97
8658 - Kleindorfer's Hardware LLC	20-(4) 1/4 tap & (4) #7 bit for Signals Crew	09/13/2024	25.60
8658 - Kleindorfer's Hardware LLC	20-PVC Plug, 2 gal safety can, pliers for concrete crew	09/13/2024	83.37
6262 - Koenig Equipment, INC	20-Tree crew supplies (16" chain, chipper blade)	09/13/2024	63.38
2974 - MacAllister Machinery Co, INC	20-skid plate for Milling Machine	09/13/2024	337.23
Account 52420 - Other Supplies Totals Invoice Transactions 6			<hr/> \$374.65



Board of Public Works Claim Register

Invoice Date Range 08/31/24 - 09/13/24

Account 53140 - Exterminator Services

51538 - Economy Termite & Pest Control, INC	20-One time special service-8/22/24	BC 2023-070	09/13/2024	275.00
Account 53140 - Exterminator Services Totals Invoice Transactions 1				\$275.00

Account 53610 - Building Repairs

6378 - ANN-KRISS, LLC	20-SA-Remove & replace door on Street Dept building	BC 2023-064	09/13/2024	3,640.00
321 - Harrell Fish, INC (HFI)	20-SA- Backed up floor drain-poured water down drain-6/18/24	BC 2023-075	09/13/2024	380.00
1537 - Indiana Door & Hardware Specialties, INC	20 - SA- Purchased grade 2 entry lock and installation	BC 2023-076	09/13/2024	255.50
Account 53610 - Building Repairs Totals Invoice Transactions 3				\$4,275.50

Account 53920 - Laundry and Other Sanitation Services

19171 - Vestis Group, INC (FKA Aramark)	20-uniform rental (minus payroll ded)-8/21/24		09/13/2024	9.01
19171 - Vestis Group, INC (FKA Aramark)	20-mat/towel service-8/21/24		09/13/2024	42.50
Account 53920 - Laundry and Other Sanitation Services Totals Invoice Transactions 2				\$51.51
Program 200000 - Main Totals Invoice Transactions 14				\$5,133.19
Department 20 - Street Totals Invoice Transactions 14				\$5,133.19
Fund 451 - Motor Vehicle Highway(S0708) Totals Invoice Transactions 14				\$5,133.19

Fund 452 - Parking Facilities(S9502)

Department 26 - Parking

Program 260000 - Main

Account 52430 - Uniforms and Tools

3588 - Cintas Corporation (Cintas #529 EFT Vendor)	26-new tshirts for new and current employees		09/13/2024	304.00
Account 52430 - Uniforms and Tools Totals Invoice Transactions 1				\$304.00

Account 53510 - Electrical Services

223 - Duke Energy	15-Trades Garage-489 W. 10th-elec chgs 07/23/24-08/21/24		09/05/2024	594.67
Account 53510 - Electrical Services Totals Invoice Transactions 1				\$594.67



Board of Public Works Claim Register

Invoice Date Range 08/31/24 - 09/13/24

Account 53840 - Lease Payments

512 - 7th & Walnut , LLC	26-Walnut St Garage-garage rent October 2024	09/13/2024	17,824.79
3887 - Mercury Development Group, LLC	26-Morton St Garage-garage rent October 2024	09/13/2024	41,706.45
Account 53840 - Lease Payments Totals Invoice Transactions 2			\$59,531.24
Program 260000 - Main Totals Invoice Transactions 4			\$60,429.91
Department 26 - Parking Totals Invoice Transactions 4			\$60,429.91
Fund 452 - Parking Facilities(S9502) Totals Invoice Transactions 4			\$60,429.91

Fund 454 - Alternative Transport(S6301)

Department 02 - Public Works

Program 020000 - Main

Account 43170.0004 - Residential Neighborhood Permits Zone # 4

Nicole Anabella Parra	26-Returned Zone 4 Permit	09/13/2024	40.00
Account 43170.0004 - Residential Neighborhood Permits Zone # 4 Totals Invoice Transactions 1			\$40.00

Account 43170.0099 - Residential Neighborhood Permits All Zones Sevice Permit

Richard Linnemeier	26-Customer purchased 2 All Zone permits, only needed 1	09/13/2024	118.00
Account 43170.0099 - Residential Neighborhood Permits All Zones Sevice Permit Totals Invoice Transactions 1			\$118.00
Program 020000 - Main Totals Invoice Transactions 2			\$158.00
Department 02 - Public Works Totals Invoice Transactions 2			\$158.00

Department 26 - Parking

Program 260000 - Main

Account 52110 - Office Supplies

8541 - Amazon.com Sales, INC (Amazon.com Services LLC)	26-hand towel paper - trash bags - air freshner - clorox	09/13/2024	43.96
6530 - Office Depot, INC	wipes 26-manilla envelopes for Parking Services office	09/13/2024	1.54
6530 - Office Depot, INC	26-2 label makers for the parking services office	09/13/2024	6.80



Board of Public Works Claim Register

Invoice Date Range 08/31/24 - 09/13/24

6530 - Office Depot, INC

26-binders - dividers - batteries - label maker tape	09/13/2024	13.70
Account 52110 - Office Supplies Totals	Invoice Transactions 4	<hr/> \$66.00
Program 260000 - Main Totals	Invoice Transactions 4	<hr/> \$66.00
Department 26 - Parking Totals	Invoice Transactions 4	<hr/> \$66.00
Fund 454 - Alternative Transport(S6301) Totals	Invoice Transactions 6	<hr/> \$224.00

Fund **455 - Parking Meter Fund(S2141)**

Department **26 - Parking**

Program **260000 - Main**

Account **52110 - Office Supplies**

8541 - Amazon.com Sales, INC (Amazon.com Services LLC)	26-telephone cord for parking office phone	09/13/2024	7.99
8541 - Amazon.com Sales, INC (Amazon.com Services LLC)	26-hand towel paper - trash bags - air freshner - clorox wibes	09/13/2024	175.85
6530 - Office Depot, INC	26-manilla envelopes for Parking Services office	09/13/2024	6.20
6530 - Office Depot, INC	26-2 label makers for the parking services office	09/13/2024	27.20
6530 - Office Depot, INC	26-binders - dividers - batteries - label maker tape	09/13/2024	54.82
	Account 52110 - Office Supplies Totals	Invoice Transactions 5	<hr/> \$272.06

Account **52340 - Other Repairs and Maintenance**

3560 - First Financial Bank / Credit Cards	26-Mail lock to vendor for new keys-LH229367318US	09/13/2024	17.00
	Account 52340 - Other Repairs and Maintenance Totals	Invoice Transactions 1	<hr/> \$17.00

Account **53230 - Travel**

3560 - First Financial Bank / Credit Cards	26-Wahl IPMI membership dues/renewal	09/13/2024	695.00
	Account 53230 - Travel Totals	Invoice Transactions 1	<hr/> \$695.00

Account **53990 - Other Services and Charges**

4574 - John Deere Financial f.s.b. (Rural King)	26-paint for parking stalls on 100 N College	09/13/2024	159.80
4443 - The Sherwin Williams Company	26-yellow paint for curbs on Washington between 2nd & Dodds	09/13/2024	259.90



Board of Public Works Claim Register

Invoice Date Range 08/31/24 - 09/13/24

4443 - The Sherwin Williams Company
 4443 - The Sherwin Williams Company
 4443 - The Sherwin Williams Company

26-yellow paint for curbs on w 12th st	09/13/2024	259.90
26-yellow curb paint-Park, Grant, Cottage Grove, 11th Sts	09/13/2024	259.90
26-yellow curb paint-Park, Grant, Cottage Grove, 11th Sts	09/13/2024	259.90
Account 53990 - Other Services and Charges Totals	Invoice Transactions 5	<u>\$1,199.40</u>
Program 260000 - Main Totals	Invoice Transactions 12	<u>\$2,183.46</u>
Department 26 - Parking Totals	Invoice Transactions 12	<u>\$2,183.46</u>
Fund 455 - Parking Meter Fund(S2141) Totals	Invoice Transactions 12	<u>\$2,183.46</u>

Fund 457 - Digital Equity Fund

Department **28 - ITS**

Program **280000 - Main**

Account **53990 - Other Services and Charges**

504 - Housing Authority Of The City of Bloomington (BHA)
 504 - Housing Authority Of The City of Bloomington (BHA)

28- Digital Equity funds Crestmont internet 07/20/24-08/19/24	09/13/2024	189.56
28- Digital Equity funds Crestmont internet 08/20/24-09/19/24	09/13/2024	189.56
Account 53990 - Other Services and Charges Totals	Invoice Transactions 2	<u>\$379.12</u>
Program 280000 - Main Totals	Invoice Transactions 2	<u>\$379.12</u>
Department 28 - ITS Totals	Invoice Transactions 2	<u>\$379.12</u>
Fund 457 - Digital Equity Fund Totals	Invoice Transactions 2	<u>\$379.12</u>

Fund 600 - Cumulative Cap Imprv(CIG)(S2379)

Department **02 - Public Works**

Program **020000 - Main**

Account **52330 - Street , Alley, and Sewer Material**

334 - Irving Materials, INC
 334 - Irving Materials, INC
 334 - Irving Materials, INC

20-Concrete Materials Class A Stone-13th & Dunn-Wash Out Bag	BC 2024-012	09/13/2024	1,292.00
20-Concrete Materials Class A Stone-209 S. Dunn St	BC 2024-012	09/13/2024	890.00
20-Concrete Materials Class A Stone-209 S. Dunn	BC 2024-012	09/13/2024	944.00



Board of Public Works Claim Register

Invoice Date Range 08/31/24 - 09/13/24

334 - Irving Materials, INC	20-Concrete Materials Class A Stone-209 S. Dunn-wash out	BC 2024-012	09/13/2024	984.00
	baas			
334 - Irving Materials, INC	20-Concrete Materials Class A Stone-Quarry Ct & Countryside Ln	BC 2024-012	09/13/2024	555.00
365 - Rogers Group, INC	20-Stone for Sidewalks Stock 08/08/24	BC 2024-012	09/13/2024	252.75
Account 52330 - Street , Alley, and Sewer Material Totals Invoice Transactions 6				\$4,917.75
Program 020000 - Main Totals Invoice Transactions 6				\$4,917.75
Department 02 - Public Works Totals Invoice Transactions 6				\$4,917.75
Fund 600 - Cumulative Cap Imprv(CIG)(S2379) Totals Invoice Transactions 6				\$4,917.75

Fund **601 - Cumulative Capital Devlp(S2391)**

Department **02 - Public Works**

Program **020000 - Main**

Account **52330 - Street , Alley, and Sewer Material**

5149 - E&B Paving, INC	20-Asphalt for Paving S. Henderson & 17th St.	BC 2023-093A	09/13/2024	14,893.45
5149 - E&B Paving, INC	20-Asphalt for Paving S Henderson-7/30/24	BC 2023-093A	09/13/2024	17,894.63
5149 - E&B Paving, INC	20-Hot mix for patching 08/01/24	BC 2023-093A	09/13/2024	364.14
5149 - E&B Paving, INC	20-Credit- Asphalt Millings-8/24/24 Cobblefield & Weatherstone	BC 2023-093A	09/13/2024	(1,289.10)
5149 - E&B Paving, INC	20-Asphalt for Paving 08/06/24 Cobblefield Ct.	BC 2023-093A	09/13/2024	16,675.47
5149 - E&B Paving, INC	20-Asphalt for Paving 08/07/24 Weatherstone Dr.	BC 2023-093A	09/13/2024	22,668.31
5149 - E&B Paving, INC	20-Asphalt for Paving 08/08/24 Weatherstone Ln.	BC 2023-093A	09/13/2024	14,589.40
Account 52330 - Street , Alley, and Sewer Material Totals Invoice Transactions 7				\$85,796.30
Program 020000 - Main Totals Invoice Transactions 7				\$85,796.30
Department 02 - Public Works Totals Invoice Transactions 7				\$85,796.30

Department **07 - Engineering**

Program **070000 - Main**

Account **54310 - Improvements Other Than Building**



Board of Public Works Claim Register

Invoice Date Range 08/31/24 - 09/13/24

399 - American Structurepoint, INC	07-2023 Signal Timing Project 07/01/24-07/31/24	BC 2023-058	09/13/2024	7,570.00
10 - Bledsoe Riggert Cooper & James INC	07-B-ine Ext, RW Staking 08/31/23	BC 2022-137	09/13/2024	1,720.00
3444 - Rundell Ernstberger Associates, INC	07-On-Call Engineering Services, REA through 07/31/24	BC 2023-043	09/13/2024	13,348.50
Account 54310 - Improvements Other Than Building Totals			Invoice Transactions 3	<hr/> \$22,638.50
Program 070000 - Main Totals			Invoice Transactions 3	<hr/> \$22,638.50
Department 07 - Engineering Totals			Invoice Transactions 3	<hr/> \$22,638.50
Fund 601 - Cumulative Capital Devlp(S2391) Totals			Invoice Transactions 10	<hr/> \$108,434.80
 Fund 730 - Solid Waste (S6401)				
Department 16 - Sanitation				
Program 160000 - Main				
Account 52230 - Garage and Motor Supplies				
8658 - Kleindorfer's Hardware LLC	16-power washer parts-pipe and elbow		09/13/2024	15.58
Account 52230 - Garage and Motor Supplies Totals			Invoice Transactions 1	<hr/> \$15.58
 Account 52420 - Other Supplies				
48 - Continental Research Corporation	16-air fresheners, rags and Urinal cleaner		09/13/2024	1,803.00
Account 52420 - Other Supplies Totals			Invoice Transactions 1	<hr/> \$1,803.00
 Account 52430 - Uniforms and Tools				
793 - Indiana Safety Company, INC	16-gloves for employees-mens brown jersey		09/13/2024	284.23
Account 52430 - Uniforms and Tools Totals			Invoice Transactions 1	<hr/> \$284.23
 Account 53140 - Exterminator Services				
51538 - Economy Termite & Pest Control, INC	16 -bi-monthly pest control- 8/26/24	BC 2023-070	09/13/2024	125.00
Account 53140 - Exterminator Services Totals			Invoice Transactions 1	<hr/> \$125.00
 Account 53240 - Freight / Other				
48 - Continental Research Corporation	16-air fresheners, rags and Urinal cleaner		09/13/2024	61.05



Board of Public Works Claim Register

Invoice Date Range 08/31/24 - 09/13/24

793 - Indiana Safety Company, INC

16-gloves for employees-mens brown jersey		09/13/2024	36.56
Account 53240 - Freight / Other Totals Invoice Transactions 2			<u>\$97.61</u>

Account **53610 - Building Repairs**

321 - Harrell Fish, INC (HFI)

16-SA- Quarterly PM Service 07/25/24	BC 2023-074	09/13/2024	576.97
--------------------------------------	-------------	------------	--------

392 - Koorsen Fire & Security, INC

16 - SA - Fire extinguisher repair and exchange	BC 2023-089	09/13/2024	212.80
---	-------------	------------	--------

Account 53610 - Building Repairs Totals Invoice Transactions 2			<u>\$789.77</u>
---	--	--	-----------------

Account **53920 - Laundry and Other Sanitation Services**

19171 - Vestis Group, INC (FKA Aramark)

16-uniform rental (minus payroll ded)- 08/28/2024		09/13/2024	6.48
---	--	------------	------

19171 - Vestis Group, INC (FKA Aramark)

16-Mat Services - 08/28/2024		09/13/2024	29.68
------------------------------	--	------------	-------

19171 - Vestis Group, INC (FKA Aramark)

16-uniform rental (minus payroll ded)- 08/21/2024		09/13/2024	6.48
---	--	------------	------

19171 - Vestis Group, INC (FKA Aramark)

16-Mat Services - 08/21/2024		09/13/2024	29.68
------------------------------	--	------------	-------

Account 53920 - Laundry and Other Sanitation Services Totals Invoice Transactions 4			<u>\$72.32</u>
--	--	--	----------------

Account **53950 - Landfill**

52226 - Hoosier Transfer Station-3140

16-recycling fees-08/01-08/15/24		09/13/2024	918.70
----------------------------------	--	------------	--------

52226 - Hoosier Transfer Station-3140

16-recycling fees-07/16-07/31/24		09/13/2024	1,046.30
----------------------------------	--	------------	----------

52226 - Hoosier Transfer Station-3140

16-trash disposal fee-08/1-08/15/24		09/13/2024	15,210.39
-------------------------------------	--	------------	-----------

52226 - Hoosier Transfer Station-3140

16-trash disposal fee-07/16-07/31/24		09/13/2024	17,082.18
--------------------------------------	--	------------	-----------

Account 53950 - Landfill Totals Invoice Transactions 4			<u>\$34,257.57</u>
---	--	--	--------------------

Program 160000 - Main Totals Invoice Transactions 16			<u>\$37,445.08</u>
---	--	--	--------------------

Department 16 - Sanitation Totals Invoice Transactions 16			<u>\$37,445.08</u>
--	--	--	--------------------

Fund 730 - Solid Waste (S6401) Totals Invoice Transactions 16			<u>\$37,445.08</u>
--	--	--	--------------------

Fund **800 - Risk Management(S0203)**

Department **10 - Legal**

Program **100000 - Main**



Board of Public Works Claim Register

Invoice Date Range 08/31/24 - 09/13/24

Account 52430 - Uniforms and Tools

1448 - Shoe Carnival, INC	10-Safety Shoes- J. Farmer 13-7/29/24	09/13/2024	100.00
1448 - Shoe Carnival, INC	10-Safety Shoes- M. Banner 12-7/27/24	09/13/2024	100.00
Account 52430 - Uniforms and Tools Totals Invoice Transactions 2			\$200.00

Account 53160 - Instruction

3560 - First Financial Bank / Credit Cards	10-OSHA Course General Industry - J Forte Plunkett	09/13/2024	808.00
Account 53160 - Instruction Totals Invoice Transactions 1			\$808.00

Account 53420 - Worker's Comp & Risk

7792 - ONB Benefit Administration LLC (JWF Specialty)	10-Workers Comp Payment (08/15/2024 - 08/21/2024)	09/03/2024	2,488.31
Account 53420 - Worker's Comp & Risk Totals Invoice Transactions 1			\$2,488.31

Account 53990 - Other Services and Charges

205 - City Of Bloomington	10-PC Reimb-Mo Co Rec-2 Waivers of Annexation-8/27	09/13/2024	50.00
Account 53990 - Other Services and Charges Totals Invoice Transactions 1			\$50.00
Program 100000 - Main Totals Invoice Transactions 5			\$3,546.31
Department 10 - Legal Totals Invoice Transactions 5			\$3,546.31
Fund 800 - Risk Management(S0203) Totals Invoice Transactions 5			\$3,546.31

Fund 801 - Health Insurance Trust

Department 12 - Human Resources

Program 120000 - Main

Account 53990 - Other Services and Charges

9037 - Everside Health, LLC	12-Everside Health Membership July 2024	09/13/2024	30,285.00
9037 - Everside Health, LLC	12-Everside Health Membership December 2023-May 2024	09/13/2024	155,697.48
9037 - Everside Health, LLC	12-Everside Health Membership June 2024	09/13/2024	30,258.92
Account 53990 - Other Services and Charges Totals Invoice Transactions 3			\$216,241.40



Board of Public Works Claim Register

Invoice Date Range 08/31/24 - 09/13/24

Account **53990.1201 - Other Services and Charges Health Insurance**

3928 - Aim Medical Trust	12 - September 2024 Medical Premiums		09/05/2024	1,071,474.80
Account 53990.1201 - Other Services and Charges Health Insurance Totals			Invoice Transactions 1	<u>\$1,071,474.80</u>
Program 120000 - Main Totals			Invoice Transactions 4	<u>\$1,287,716.20</u>
Department 12 - Human Resources Totals			Invoice Transactions 4	<u>\$1,287,716.20</u>
Fund 801 - Health Insurance Trust Totals			Invoice Transactions 4	<u>\$1,287,716.20</u>

Fund **802 - Fleet Maintenance(S9500)**

Department **17 - Fleet Maintenance**

Program **170000 - Main**

Account **52230 - Garage and Motor Supplies**

50605 - Bauer Built, INC	17 - scrap tire disposal (22) - 08/21/24		09/13/2024	117.75
50605 - Bauer Built, INC	17 - scrap tire disposal (31)- 8/16/24		09/13/2024	155.00
50605 - Bauer Built, INC	17 -(4) 11R225 H XZE2 tires		09/13/2024	2,087.80
4693 - Monroe County Tire & Supply, INC	17 - (1) Goodyear Wrangler tire for 876		09/13/2024	173.25
4693 - Monroe County Tire & Supply, INC	17 - (1) Alliance farm pro 303, Firestone tube TR15, 6 hole farm		09/13/2024	275.25
Account 52230 - Garage and Motor Supplies Totals			Invoice Transactions 5	<u>\$2,809.05</u>

Account **52240 - Fuel and Oil**

7854 - Premier AG CO-OP, INC (Premier Energy)	17-fuel-B20 PDX4 Clear on Road (6,954 gallons)-8/26/24	BC 2023-105B	09/13/2024	21,297.32
7854 - Premier AG CO-OP, INC (Premier Energy)	17-fuel-B20 PDX4 Clear on Road (7,145 gallons)-8/7/24	BC 2023-105B	09/13/2024	22,581.77
7854 - Premier AG CO-OP, INC (Premier Energy)	17-fuel-87 regular (7,936 gallons)-8/14/24	BC 2023-105B	09/13/2024	26,775.27
7854 - Premier AG CO-OP, INC (Premier Energy)	1-fuel-87 regulard (7,912 gallons)-8/7/24	BC 2023-105B	09/13/2024	27,707.03
362 - Schaeffer Manufacturing Company	17- various oils & grease		09/13/2024	5,553.05
Account 52240 - Fuel and Oil Totals			Invoice Transactions 5	<u>\$103,914.44</u>

Account **52320 - Motor Vehicle Repair**



Board of Public Works Claim Register

Invoice Date Range 08/31/24 - 09/13/24

8541 - Amazon.com Sales, INC (Amazon.com Services LLC)	17 - filters	09/13/2024	75.31
8541 - Amazon.com Sales, INC (Amazon.com Services LLC)	17 - valve, brake fittings and nitrile gloves	09/13/2024	297.75
244 - Bloomington Ford, INC	17 - Rear Glass Assembly for C114	09/13/2024	90.54
594 - Curry Auto Center, INC	17 - SL-N-Block for 583	09/13/2024	149.56
4992 - Fleetpride, INC	17 - seals for 966	09/13/2024	208.33
4992 - Fleetpride, INC	17 - brake drums for 966	09/13/2024	987.58
5168 - Jasper Engine Exchange, INC	17 - #572 rebuilt coder	09/13/2024	359.00
5168 - Jasper Engine Exchange, INC	17 - #638 rebuilt turbo	09/13/2024	1,525.00
5168 - Jasper Engine Exchange, INC	17 - #572 rebuilt transmission	09/13/2024	3,461.00
908 - JB Salvage (Westside Auto Parts)	17 - #9300 misc steel for fabrication-8/20/24	09/13/2024	394.00
53385 - O'Reilly Automotive Stores, INC	17 - Hose Clips for 291	09/13/2024	10.44
53385 - O'Reilly Automotive Stores, INC	17 -Air filter for 116	09/13/2024	15.83
53385 - O'Reilly Automotive Stores, INC	17 - Head cleaner for 964	09/13/2024	17.99
53385 - O'Reilly Automotive Stores, INC	17 - Bead Buster for stock	09/13/2024	25.59
53385 - O'Reilly Automotive Stores, INC	17 -Belt Tensner & Micro-V Belt for P138	09/13/2024	78.89
53385 - O'Reilly Automotive Stores, INC	17 -Oil filter, drain pan, air filter & cabin filter for C114	09/13/2024	79.52
53385 - O'Reilly Automotive Stores, INC	17 - New CB shift for P131	09/13/2024	102.00
53385 - O'Reilly Automotive Stores, INC	17 - (2) control arm assemblies & torque mount for 1130	09/13/2024	323.56
53385 - O'Reilly Automotive Stores, INC	17 - credit for core returned-8/22/24	09/13/2024	(49.73)
53385 - O'Reilly Automotive Stores, INC	17 - credit for core returned-Inv #1903-456818	09/13/2024	(300.00)
16069 - Palmer Trucks, INC	17 - #720 Valve-2.0 ton Expan., evaporator coil & o-ring HAV kit	09/13/2024	553.88
4156 - Pyramid Equipment, INC	17 - #966 prox switch	09/13/2024	187.40
4547 - Riddle Tractor Sales (Lawrence County Equip.)	17 - #755 Assembly filters, Cartridge filter, & Oil filter	09/13/2024	760.97
5333 - Total Truck Parts, INC	17 - #9300 Oil seal	09/13/2024	318.47



Board of Public Works Claim Register

Invoice Date Range 08/31/24 - 09/13/24

5333 - Total Truck Parts, INC	17 - #445 Power steering pump & gasket	09/13/2024	609.78
5333 - Total Truck Parts, INC	17 - #445 gear box-includes core charge	09/13/2024	1,379.74
5333 - Total Truck Parts, INC	17 - credit for core on gear box against invoice W3*258231	09/13/2024	(600.00)
622 - Truck Country of Indiana, INC (Stoops Freightliner	17 - (2) Female tee push to fitting for 384	09/13/2024	56.20
622 - Truck Country of Indiana, INC (Stoops Freightliner	17 -Gasket, V Band clamp, pipe clamp for 598	09/13/2024	158.51
622 - Truck Country of Indiana, INC (Stoops Freightliner	17 - plastic tank-surge for 384	09/13/2024	290.99
622 - Truck Country of Indiana, INC (Stoops Freightliner	17 - exhaust flex tube, clamp kit, clamp-V Band for 598	09/13/2024	729.60
622 - Truck Country of Indiana, INC (Stoops Freightliner	17 -Combination switch for 964	09/13/2024	746.12
622 - Truck Country of Indiana, INC (Stoops Freightliner	17 - credit for returned part - Air RKR switch	09/13/2024	(87.53)
7555 - VoMac Truck Sales & Service INC	17 -2 Oil Filters for 958	09/13/2024	29.46
2096 - West Side Tractor Sales CO.	17 - fuel filter for 737	09/13/2024	5.57
2096 - West Side Tractor Sales CO.	17 - Filter Element for 866	09/13/2024	19.45
2096 - West Side Tractor Sales CO.	17 - Street pad, washer, & 3/8 nut for 866	09/13/2024	377.67
2096 - West Side Tractor Sales CO.	17 - Window, washer, latch blew out in storm - FEMA for 623	09/13/2024	426.19
2096 - West Side Tractor Sales CO.	17 - Hy-gard oil for inventory	09/13/2024	1,151.70
Account 52320 - Motor Vehicle Repair Totals Invoice Transactions 39			\$14,966.33

Account 52420 - Other Supplies

177 - Indiana Oxygen Company, INC	17 - 20 lb propane cylinder	09/13/2024	18.67
8658 - Kleindorfer's Hardware LLC	17 - 2" Galvanized coupler for 4004	09/13/2024	18.19
8181 - Lawson Products, INC	17 - misc parts and shop supplies - 8/16/24	09/13/2024	452.46
53442 - Paragon Micro, INC	17 - 2 new laptops and scanner for temp employees	09/13/2024	4,009.95
337 - Stansifer Radio Co, INC	17 -20 Lighium Manganese dioxide coin cell batteries for shop	09/13/2024	31.20
Account 52420 - Other Supplies Totals Invoice Transactions 5			\$4,530.47

Account 53140 - Exterminator Services



Board of Public Works Claim Register

Invoice Date Range 08/31/24 - 09/13/24

51538 - Economy Termite & Pest Control, INC

17-monthly pest control - 8/20/24 BC 2023-070 09/13/2024 95.00

Account **53140 - Exterminator Services** Totals Invoice Transactions 1 95.00

Account 53610 - Building Repairs

321 - Harrell Fish, INC (HFI)

17-SA-Quarterly planned maintenance-7/23/24 BC 2023-074 09/13/2024 277.65

Account **53610 - Building Repairs** Totals Invoice Transactions 1 \$277.65

Account 53620 - Motor Repairs

4474 - Ken's Westside Service & Towing, LLC

17-tow Unit #135-8/17/24 09/13/2024 120.00

4474 - Ken's Westside Service & Towing, LLC

17-tow-2017 Peterbilt 348-8/19/24 09/13/2024 325.00

6476 - Samuel D Wray (Wray Automotive)

17 - alignment for 134 09/13/2024 100.00

6476 - Samuel D Wray (Wray Automotive)

17 - alignment for 858 09/13/2024 100.00

Account **53620 - Motor Repairs** Totals Invoice Transactions 4 \$645.00

Account 53640 - Hardware and Software Maintenance

3560 - First Financial Bank / Credit Cards

17-AutoAuth.com-Update for the diagnostic computer 09/13/2024 50.00

Account **53640 - Hardware and Software Maintenance** Totals Invoice Transactions 1 \$50.00

Account 53650 - Other Repairs

3286 - Peacetree, INC (PEI Maintenance)

17 - cleaned key reader at Adams ST-8/19/24 09/13/2024 142.50

Account **53650 - Other Repairs** Totals Invoice Transactions 1 \$142.50

Account 53920 - Laundry and Other Sanitation Services

19171 - Vestis Group, INC (FKA Aramark)

17 - city portion of uniform rentals - 8/7/24 09/13/2024 26.76

19171 - Vestis Group, INC (FKA Aramark)

17 - City portion-uniform rentals - 8/14/24 09/13/2024 26.76

19171 - Vestis Group, INC (FKA Aramark)

17 - City portion-uniform rentals - 8/21/24 09/13/2024 27.41

19171 - Vestis Group, INC (FKA Aramark)

17 - mat rentals and shop towels- 8/14/24 09/13/2024 93.34

19171 - Vestis Group, INC (FKA Aramark)

17 - mat rentals & shop towels, 8/7/24 09/13/2024 93.34

19171 - Vestis Group, INC (FKA Aramark)

17 - mat rentals and shop towels- 8/21/24 09/13/2024 93.34



Board of Public Works Claim Register

Invoice Date Range 08/31/24 - 09/13/24

Account 53920 - Laundry and Other Sanitation Services Totals			Invoice Transactions 6	\$360.95
Account 53990 - Other Services and Charges				
3560 - First Financial Bank / Credit Cards	17-BMV-title fees for City vehicle - 8/15/24		09/13/2024	15.00
3560 - First Financial Bank / Credit Cards	17-BMV-title fees for (3) City vehicles-8/15/24		09/13/2024	45.00
3560 - First Financial Bank / Credit Cards	17 - toll fees for unit 401 06-25-2024		09/13/2024	5.04
Account 53990 - Other Services and Charges Totals			Invoice Transactions 3	\$65.04
Program 170000 - Main Totals			Invoice Transactions 71	\$127,856.43
Department 17 - Fleet Maintenance Totals			Invoice Transactions 71	\$127,856.43
Fund 802 - Fleet Maintenance(\$9500) Totals			Invoice Transactions 71	\$127,856.43
Fund 804 - Insurance Voluntary Trust				
Department 12 - Human Resources				
Program 120000 - Main				
Account 53990.1271 - Other Services and Charges Section 125 - URM- City				
9375 - WEX Health INC (Chard, Snyder & Associates)	12-City URM		09/03/2024	79.00
9375 - WEX Health INC (Chard, Snyder & Associates)	12-City/Util URM		09/03/2024	35.29
9375 - WEX Health INC (Chard, Snyder & Associates)	12-City URM		09/03/2024	145.00
9375 - WEX Health INC (Chard, Snyder & Associates)	12-City URM			485.78
9375 - WEX Health INC (Chard, Snyder & Associates)	12-City URM			25.00
Account 53990.1271 - Other Services and Charges Section 125 - URM- City Totals			Invoice Transactions 5	\$770.07
Account 53990.1281 - Other Services and Charges Section 125 - URM- Util				
9375 - WEX Health INC (Chard, Snyder & Associates)	12-City/Util URM		09/03/2024	35.72
9375 - WEX Health INC (Chard, Snyder & Associates)	12-Util URM		09/04/2024	168.00
Account 53990.1281 - Other Services and Charges Section 125 - URM- Util Totals			Invoice Transactions 2	\$203.72
Account 53990.1282 - Other Services and Charges Section 125 - DDC- Util				



Board of Public Works Claim Register

Invoice Date Range 08/31/24 - 09/13/24

9375 - WEX Health INC (Chard, Snyder & Associates)	12-Utility DDC-9/5/2024	870.00
Account 53990.1282 - Other Services and Charges Section 125 - DDC- Util Totals Invoice Transactions 1		<u>\$870.00</u>

Account **53990.1283 - Other Services and Charges Health Savings Account**

9375 - WEX Health INC (Chard, Snyder & Associates)	12-HSA Employee Contributions 09/05/24	26,842.82
Account 53990.1283 - Other Services and Charges Health Savings Account Totals Invoice Transactions 1		<u>\$26,842.82</u>
Program 120000 - Main Totals Invoice Transactions 9		<u>\$28,686.61</u>
Department 12 - Human Resources Totals Invoice Transactions 9		<u>\$28,686.61</u>
Fund 804 - Insurance Voluntary Trust Totals Invoice Transactions 9		<u>\$28,686.61</u>

Fund **805 - Unemployment Comp Non-Reverting**

Department **12 - Human Resources**

Program **120000 - Main**

Account **51240 - Unemployment Compensation**

3560 - First Financial Bank / Credit Cards	12-State of IN DWD-employer liability payment	09/13/2024	195.63
Account 51240 - Unemployment Compensation Totals Invoice Transactions 1			<u>\$195.63</u>
Program 120000 - Main Totals Invoice Transactions 1			<u>\$195.63</u>
Department 12 - Human Resources Totals Invoice Transactions 1			<u>\$195.63</u>
Fund 805 - Unemployment Comp Non-Reverting Totals Invoice Transactions 1			<u>\$195.63</u>

Fund **987 - Econ Dev LIT Bonds of 2022**

Department **06 - Controller's Office**

Program **060000 - Main**

Account **54510 - Other Capital Outlays**

595 - Weddle Bros Construction Co., INC	06-Public Safety Improvements, App 13	09/13/2024	52,081.17
Account 54510 - Other Capital Outlays Totals Invoice Transactions 1			<u>\$52,081.17</u>
Program 060000 - Main Totals Invoice Transactions 1			<u>\$52,081.17</u>



Board of Public Works Claim Register

Invoice Date Range 08/31/24 - 09/13/24

Program **08FIR1 - Fire Station 1**

Account **54510 - Other Capital Outlays**

3560 - First Financial Bank / Credit Cards

6985 - Martin Riley, INC

08-Duke Electric conversion of overhead to underground services	09/13/2024	2,094.93
08-construction administration for FS#1-period ending 7/31/24	09/13/2024	38,339.00
Account 54510 - Other Capital Outlays Totals Invoice Transactions 2		<u>\$40,433.93</u>
Program 08FIR1 - Fire Station 1 Totals Invoice Transactions 2		<u>\$40,433.93</u>

Program **08FIRA - Fire Shower's West**

Account **54510 - Other Capital Outlays**

6728 - Precision Quality Contracting, LLC

6728 - Precision Quality Contracting, LLC

4443 - The Sherwin Williams Company

4443 - The Sherwin Williams Company

08-run fiber & cat lines for new HQ	09/13/2024	2,862.00
08-Install 12f FOC and 1"flex duct splicing, testing -new HO	09/13/2024	6,933.20
08-Painting supplies for Showers West BFD Admin Offices	09/13/2024	892.29
08-Paint-Showers West BFD Admin Offices-40 5 gallon	09/13/2024	1,599.20
Account 54510 - Other Capital Outlays Totals Invoice Transactions 4		<u>\$12,286.69</u>
Program 08FIRA - Fire Shower's West Totals Invoice Transactions 4		<u>\$12,286.69</u>
Department 06 - Controller's Office Totals Invoice Transactions 7		<u>\$104,801.79</u>
Fund 987 - Econ Dev LIT Bonds of 2022 Totals Invoice Transactions 7		<u>\$104,801.79</u>
Grand Totals Invoice Transactions 347		<u>\$2,073,956.94</u>

REGISTER OF CLAIMS
Board of Public Works Claim Register

Date:	Type of Claim	FUND	Description	Bank Transfer	Amount
09/13/24	Claims				\$2,073,956.94

\$2,073,956.94

ALLOWANCE OF CLAIMS

We have examined the claims listed on the foregoing register of claims, consisting of claims, and except for the claims not allowed as shown on the register, such claims are hereby allowed in the total amount of **\$2,073,956.94**

Dated this _____ **day of** _____ **year of 20**_____.

herby certify that each of the above listed voucher(s) or bill(s) is (are) true and correct and I have audited same in accordance with IC 5-11-10-1.6.

Fiscal Office _____