

AGENDA
REDEVELOPMENT COMMISSION
McCloskey Conference Room
March 19, 2018
5:00 p.m.

- I. ROLL CALL**
- II. READING OF THE MINUTES** –March 5, 2018
- III. EXAMINATION OF CLAIMS** –March 9, 2018 for \$341,333.80
- IV. EXAMINATION OF PAYROLL REGISTERS**–March 2, 2018 for \$30,461.67
- V. REPORT OF OFFICERS AND COMMITTEES**
 - A. Director’s Report
 - B. Legal Report
 - C. Treasurer’s Report
 - D. CTP Update Report
Switchyard Park Status Report
- VI. NEW BUSINESS**
 - A. Resolution 18-18: Project Review and Approval for RCA Park Rehabilitation
 - B. Resolution 18-19: Amending Resolution 17-19 to approve Change Orders for the Animal Shelter Construction
- VII. BUSINESS/GENERAL DISCUSSION**
- VIII. ADJOURNMENT**

Auxiliary aids for people with disabilities are available upon request with adequate notice. Please call 812-349-3429 or e-mail human.rights@bloomington.in.gov.

THE REDEVELOPMENT COMMISSION OF THE CITY OF BLOOMINGTON, INDIANA MET on Monday, March 5, 2018 at 5:00 p.m. in the Showers City Hall, McCloskey Conference Room, 401 North Morton Street, with Donald Griffin, Jr. presiding

I. ROLL CALL

Commissioners Present: Don Griffin, David Walter, Mary Alice Rickert, Sue Sgambelluri, Eric Sandweiss, Kelly Smith

Commissioners Absent: None

Staff Present: Doris Sims, Director, Housing and Neighborhood Development (HAND); Christina Finley, Financial Specialist, HAND Department

Others Present: Philippa Guthrie, Corporation Counsel, City Legal Department; Larry Allen, Assistant Attorney, City Legal Department; Kurt Christian, Herald-Times; Alex Crowley, Director, Economic & Sustainable Development

- II. READING OF THE MINUTES** –David Walter made a motion to approve the February 19, 2018 minutes. Eric Sandweiss seconded the motion. The board unanimously approved.
- III. EXAMINATION OF CLAIMS** –Dave Walter made a motion to approve the claim registers for February 23, 2018 for \$449,435.12. Mary Alice Rickert seconded the motion. The board unanimously approved.
- IV. EXAMINATION OF PAYROLL REGISTERS** –Sue Sgambelluri made a motion to approve the payroll registers for February 16, 2018 for \$30,497.23. Mary Alice Rickert seconded the motion. The board unanimously approved.
- V. REPORT OF OFFICERS AND COMMITTEES**
- A. Director’s Report. Doris Sims was available to answer questions.
 - B. Legal Report. Philippa Guthrie was available to answer questions.
 - C. Treasurer’s Report. Jeff Underwood was available to answer questions.
 - D. CTP Update Report. Alex Crowley was available to answer questions.
- VI. NEW BUSINESS**
- A.** Resolution 18-17: Approval of Agreement with Urban Land Institute RE: IU Health Hospital Site. Philippa Guthrie stated staff has negotiated a contract with the Urban Land Institute (ULI), as a professional consultant to assist the City in envisioning the future redevelopment and uses of the old hospital site. ULI will put together a panel of 7-8 experts from around the country, for the community. They will be in Bloomington the week of April 8, 2018 and will interview approximately 100 stakeholders in the community.

Sue Sgamelluri asked if the \$135,000 fee is typical. Guthrie stated it is their standard fee.

Eric Sandweiss asked if there are sufficient funds available. Philippa Guthrie stated sufficient funds are available.

Alex explained that ULI will perform the study and submit a formal report 4-6 weeks later. He stated the study is the first in a series of efforts that will be taken to get community input.

Don Griffin asked for public comment. There was no public comment.

David Walter made a motion to approve Resolution 18-17. Eric Sandweiss seconded the motion. The board unanimously approved.

VII. BUSINESS/GENERAL DISCUSSION

VIII. ADJOURNMENT

Donald Griffin, President

Mary Alice Rickert, Secretary

Date

**18-18
RESOLUTION
OF THE
REDEVELOPMENT COMMISSION
OF THE
CITY OF BLOOMINGTON, INDIANA**

**APPROVAL OF PROJECT REVIEW AND APPROVAL FORM REGARDING RCA PARK
REHABILITATION**

WHEREAS, the City of Bloomington (“City”) has brought the Redevelopment Commission a Project Review & Approval Form (“Form”), which seeks the support of the RDC to rehabilitate RCA Park, which includes extending accessibility on the North pedestrian loop trail, reconstructing the South pedestrian loop trail, and replacing the roof on the group shelter (“Project”); and

WHEREAS, a copy of the Form is attached to this Resolution as Exhibit A;

NOW, THEREFORE, BE IT RESOLVED BY THE REDEVELOPMENT COMMISSION OF THE CITY OF BLOOMINGTON, INDIANA, THAT:

1. The Redevelopment Commission finds that the Project has a valid public purpose, and approves the Project.
2. The expenditure of funds is not approved by this Resolution. Funding will be approved at a later date when the Project Manager brings a Contract or Contracts that have been prepared after complying with the appropriate City procurement process for the Project.

BLOOMINGTON REDEVELOPMENT COMMISSION

Donald Griffin, President

ATTEST:

Mary Alice Rickert, Secretary

Date

City of Bloomington
Redevelopment Commission
Project Review & Approval Form

Please Note:

- Approval of the project by the Redevelopment Commission through this Project Review & Approval Form does not represent an authorization to begin work or expend funds.
- Authorization of work and the commitment of funds shall be done when the Redevelopment Commission reviews and approves: (1) a Purchase Order or Contract prepared after complying with the appropriate procurement process for the type of item, service or construction being sought and (2) the estimated costs associated with the Purchase Order or Contract.
- No payment of funds shall be made without a duly authorized and approved Purchase Order or Contract. All claims for payment against a duly authorized Purchase Order or Contract shall be submitted to the Redevelopment Commission for their review and approval along with any required departmental inspections, reviews and approvals prior to the payment of any funds.

To Be Completed by Requesting Party:

Project Name: RCA Park Rehabilitation – Roof Group Shelter, North and South loop trail reconstruction

Project Manager: Dave Williams, Operations Director, Parks and Recreation

Project Description: This is a project to rehabilitate RCA Park, and will include the following improvements:

Group Shelter

Reroof the group shelter with new underlayment and metal roofing panels.
Estimated project cost: \$18,000.

North and South Loop Trail

Reconstruction of the southern pedestrian loop trail at RCA Park (original construction 1994) is needed due to severe erosion caused by upstream development rendering the existing trail impassable in some areas. The north loop trail requires the construction of an accessible paved connection from the northwest corner south to the parking lot. The project requires new asphalt pavement, boardwalk replacement, and the installation of additional stormwater drainage conveyances. This project requires the services of a design consultant to prepare bidding documents, secure construction in the floodplain permits, and assist with construction inspection. Please attached aerial photo. Estimated project cost: \$180,000

Project Timeline:

Roof Group Shelter

Start Date: May 2018
End Date: July 2018

North and South Loop Trail reconstruction

Start Date: April 2018
End Date: 2019

Financial Information:

Estimated full cost of project:	\$198,000
Sources of funds:	Consolidated TIF / 2015 TIF Bond

Project Phases: This breakdown should mirror the contract(s) expected to be issued for this project. Each phase should include a description of the work to be performed, the cost, and the timeline for the contract.

Step	Description	Quoted Cost	Timeline
1. 2. 3a. 3b.	<u>Roof Group Shelter</u> Solicit quotations – March/April 2018 Contract approval-April 2018 Start Construction – May 2018 Completion – July 2018	TBD	2018
1. 2. 3a. 3b.	<u>North and South Loop Trail reconstruction</u> Consultant contract approval-April 2018 Design and permitting-April-October 2018 Construction – 2019 Project Completion – 2019	TBD	2018-2019

TIF District: Consolidated TIF (Thomson Walnut Winslow)

Resolution History: None to date

To Be Completed by Redevelopment Commission Staff:

Approved on _____

By Resolution _____ by a vote of _____

Redevelopment Commision Resolution 18-18
Exhibit B



**18-19
RESOLUTION
OF THE
REDEVELOPMENT COMMISSION
OF THE
CITY OF BLOOMINGTON, INDIANA**

**THIRD AMENDMENT OF FUNDING APPROVAL IN REDEVELOPMENT
COMMISSION RESOLUTION 17-19 (ANIMAL SHELTER CONSTRUCTION)
TO APPROVE CHANGE ORDERS**

WHEREAS, the Redevelopment Commission of the City of Bloomington (“RDC”) issued its “Redevelopment District Tax Increment Revenue Bonds of 2015” (the “2015 TIF Bond”) to “spur, promote, and encourage the development and redevelopment of the Consolidated Economic Development Area” including the upgrade of the Animal Shelter; and

WHEREAS, in Resolution 15-48, the RDC approved a Project Review and Approval Form (“Form”) supporting the upgrade of the Animal Shelter; and

WHEREAS, in Resolution 17-19, the RDC approved funding for a contract to Neidigh Construction Corporation (“Neidigh”) in the amount of One Million Nine Hundred Forty Thousand Eleven Dollars (\$1,940,011) for the construction contract for the Animal Shelter; and

WHEREAS, in Resolution 17-70, the RDC approved a change order to the construction contract that increased the cost of the construction of the Project by \$40,433.62 to \$1,980,444.62 and extended the completion date from January 31, 2018 to February 27, 2018; and

WHEREAS, in Resolution 18-11, the RDC approved a change order to the construction contract that increased the cost of the construction of the Project by Fifteen Thousand Dollars (\$15,000) to One Million Nine Hundred and Ninety-Five Thousand Four Hundred and Forty-Four Dollars and Sixty-Two Cents (\$1,995,444.62) and extended the completion date from February 27, 2018 to August 1, 2018; and

WHEREAS, City Staff and Neidigh believe that two more change orders to the construction contract are appropriate, including a Third Change Order in the amount of \$18,029.46, and a Fourth Change Order in the amount of \$28,388.69; and

WHEREAS, copies of the proposed change orders are attached to this Resolution as Exhibit A and B; and these Third and Fourth Change Orders would increase the cost of the contract by \$46,418.07; and

WHEREAS, there are sufficient funds in the 2015 TIF Bond to pay for the Third and Fourth Change Orders; and

WHEREAS, the City has brought the RDC an Amended Form which updates the expected cost of the Project, and which is attached to this Resolution as Exhibit C.

NOW, THEREFORE, BE IT RESOLVED BY THE REDEVELOPMENT COMMISSION OF THE CITY OF BLOOMINGTON, INDIANA, THAT:

1. The RDC reaffirms its approval of the Project, as set forth in more detail on the Amended Form.
2. The RDC amends the funding approval it made in Resolution 17-19 and amended in Resolution 17-70 and Resolution 18-11. The most recent funding approval made in Resolution 18-11 for an amount not to exceed \$1,995,444.62 to pay for the construction is amended to an amount not to exceed Two Million Forty-One Thousand Eight Hundred Sixty-Two and Sixty-Nine Cents (\$2,041,862.69) for the construction project. For the avoidance of doubt, Resolution 17-19 remains otherwise unchanged.
3. The amendment contained the paragraph above is contingent upon the Board of Public Works approving the Third and Fourth Change Orders. Staff is asked to ensure that fully executed copies of the Third and Fourth Change Orders are kept with the RDC's files.

BLOOMINGTON REDEVELOPMENT COMMISSION

Donald Griffin, President

ATTEST:

Mary Alice Rickert, Secretary

Date

DRAFT AIA® Document G701™ - 2001

Change Order

PROJECT (Name and address):

City of Bloomington-
Board of Public Works
401 N. Morton Street, suite 120
Bloomington, IN 47404

CHANGE ORDER NUMBER: 003 FINAL

DATE: February 23, 2018

OWNER:

ARCHITECT:

CONTRACTOR:

FIELD:

OTHER:

TO CONTRACTOR (Name and address):

Neidigh Construction Corporation
2220 W. Vernal Pike
Bloomington, IN 47404

ARCHITECT'S PROJECT NUMBER: 2015-14

CONTRACT DATE: March 7, 2017

CONTRACT FOR: General Construction

THE CONTRACT IS CHANGED AS FOLLOWS:

(Include, where applicable, any undisputed amount attributable to previously executed Construction Change Directives)

- | | |
|--|-------------|
| 1. Rock Excavation at Water Pit. Add 1 day (CR #8) | \$ 2,070.00 |
| 2. Additional Landscape requested by COB. Add 3 days (PR-1 / CR#9) | \$ 4,155.90 |
| 3. Add Heat to the Sallyport. Add 5 days (CR#10) | \$ 4,962.20 |
| 4. Replace scheduled Faucets with requested faucets (CR#11) | \$ 1,632.61 |
| 5. Extend Sprinkler Piping into Lobby per variance. Add 3 days (CR#12) | \$ 5,208.75 |

Total for all items this Change Order \$ 18,029.46

The original Contract Sum was

The net change by previously authorized Change Orders

The Contract Sum prior to this Change Order was

The Contract Sum will be increased by this Change Order in the amount of

The new Contract Sum including this Change Order will be

	\$ 1,940,011.00
	\$ 56,433.62
	\$ 1,996,444.62
	\$ 18,029.46
	\$ 2,014,474.08

The Contract Time will be increased by twelve work days (12 work) days.

The date of Substantial Completion as of the date of this Change Order therefore is changed from January 31, 2018 to March 15, 2018.

NOTE: This Change Order does not include changes in the Contract Sum, Contract Time or Guaranteed Maximum Price which have been authorized by Construction Change Directive until the cost and time have been agreed upon by both the Owner and Contractor, in which case a Change Order is executed to supersede the Construction Change Directive.

NOT VALID UNTIL SIGNED BY THE ARCHITECT, CONTRACTOR AND OWNER.

Kirkwood Design Studio, PC

Neidigh Construction Corporation

City of Bloomington-
Board of Public Works

ARCHITECT (Firm name)

CONTRACTOR (Firm name)

OWNER (Firm name)

113 East 6th Street
Bloomington, IN 47408

2220 West Vernal Pike
Bloomington, IN 47404

401 N. Morton Street
Bloomington, IN 47404

ADDRESS

ADDRESS

ADDRESS

Mary J. Krupinski
BY (Signature)

Larry Neidigh
BY (Signature)

[Signature]
BY (Signature)

Mary J. Krupinski, AIA, President
(Typed name)

Larry Neidigh, Pres.
(Typed name)

[Typed name]
(Typed name)

February 23, 2018

02/26/2018

DATE

DATE

DATE

CHANGE REQUEST / ESTIMATE # 8

CONTRACTOR: Neidigh Construction Corporation
ADDRESS: 2220 West Vernal Pike
 Bloomington, IN 47404
Tel: (812) 334-0362 **Fax:** (812) 334-3144

JOB: Animal Care & Control Shelter
 3410 S. Walnut Street
 Bloomington, IN 47401
 Project # 2015-14

Kirkwood Design Studio
 113 East 6th Street
 Bloomington, IN 47408
 Attn: Mary Krupinski

Date: 12/14/2017

ADD TO CONTRACT

Please accept the following as our proposal to furnish labor, equipment and supervision required to complete the above referenced project per plans and addenda submitted.

		Material	Labor	Equipment	Total
Rock Excavation					
Rock removal / Backhoe with driver	9.5 Hrs		522.50	807.50	1,330.00
Haul Debris / Dump Truck w/ Driver	3.5 Hrs		122.50	227.50	350.00
Project Manager	2 hrs @	65.00	130.00		130.00
Administrative	1 hrs @	35.00	35.00		35.00
			810.00	1035.00	1845.00
Equipment - Mark-up 10%					103.50
Labor - Mark-up 15%					121.50
			Total		2,070.00

Add - 1 day to contract

Response By: Kent Kimmel
 Larry Neidigh

Date of Response: 12/14/2017

Accepted by:

Date of Acceptance:

JOB NAME Animal Shelter
 JOB NO. 17-06
 START TIME 7:00 FINISH TIME 5:00

DAILY JOB REPORT

DAY OF WEEK Thur
 DATE 10-19-17 WEATHER clear
 TEMPERATURE 55 AM 75 PM

SUPERVISOR _____

EMPLOYEES	NAME	EMPLOYEE #	PHASE	ACTIVITY	HOURS	DESCRIPTION
	David Neidigh	8312	010	040	1	Supervision
			020	043	4	water supply excavation
		6?	extra		5 1/2	rock excavation for water sup
	Andy Clark	0178	020	043	9 1/2	Install 6", 4" and 3" water supply main pipes
	Joe Baker	1476	020	043	8	Install 6", 4" & 3" water supply main pipes
	Jeff Helms	8636	050	000	8	Put up metal ceilings
	Bob Hamilton	3438	050	000	8	put up metal ceilings
	Steve Maze	6239	050	000	8	put up metal ceilings
	Brent Jost	521				day off
Nick Brooks	4271	020	043	3 1/2	haul off rock from rock excavation	
		extra				

MATERIAL	QTY.	MATERIAL RECEIVED	COMPUTER USE ONLY

EQUIPMENT	ON PROJECT	HRS.	RENTED	RATE	HRS.
	580 Case backhoe	4	McAllister Cat rental		
	287 Cat truck loader	2	Backhoe with hoe ram		5 1/2

SUBCONT.	NAME	WORK PERFORMED
	Gaylor electric 1 man 8hrs	electrical rough in
	Air master 2 men 8hrs	HVAC duct rough in
	Sim plumbing 1 man 8hrs	Insulate pipe
RWS 2 men 8hrs	Insulate walls & ceilings	

CHANGES	CHANGE ORDERS / ADDITIONAL WORK	VISITORS TO SITE / REMARKS

ADDITIONAL COMMENTS:

JOB NAME Animal Shelter
 JOB NO. 17-06
 START TIME 7:00 FINISH TIME 4:30

DAILY JOB REPORT

DAY OF WEEK Wed
 DATE 10-18-17 WEATHER clear
 TEMPERATURE 55 AM 75 PM

SUPERVISOR _____

EMPLOYEES	NAME	EMPLOYEE #	PHASE	ACTIVITY	HOURS	DESCRIPTION
	David Neidigh	8312	010	040	1	Supervision
			020	043	5	water supply excavation
		010 308	extra		4	rock excavation
	Andy Clark	0178	020	043	6 1/2	water supply excavation
			extra		2	rock excavation
	Jeff Helms	8636	050	000	8 1/2	Install metal ceilings
	Bob Hamilton	3438	050	000	8 1/2	Install metal ceilings
	Joe Baker	1476	050	000	8 1/2	Install metal ceilings
	Steve Maze	6239	050	000	8	Install metal ceilings
Brent Jost					day off	
Logan	tradesman			5 1/2	clean job site	
	8:00 to 1:30					
Nick Brooks		020	043	8	water supply excavation + haul stone to Jobsite	

MATERIAL	QTY.	MATERIAL RECEIVED	COMPUTER USE ONLY
	9	tons # 7 stone	80
	9	tons # 11 stone	
		Dry wall truck load	
	metal ceiling material		

EQUIPMENT	ON PROJECT	HRS.	RENTED	RATE	HRS.
	580 case backhoe	7	McAllister Cat rental		3
	287 Cat loader	1	Backhoe w/ hoe ram rock excavation		

SUBCONT.	NAME	WORK PERFORMED
	Gaylor electric 1 man 8hrs	electrical rough in
	Air master 2 men 8hrs	HVAC duct rough in
	Sim Plumbing 1 man 8hrs	Insulate pipe
RWS 4 men 8hrs	Insulate ceilings + walls	

CHANGES	CHANGE ORDERS / ADDITIONAL WORK	VISITORS TO SITE / REMARKS

ADDITIONAL COMMENTS:

CHANGE REQUEST / ESTIMATE #9

CONTRACTOR: Neidigh Construction Corporation
ADDRESS: 2220 West Vernal Pike
Bloomington, IN 47404
Tel: (812) 334-0362 Fax: (812) 334-3144

JOB: Animal Care & Control Shelter
3410 S. Walnut Street
Bloomington, IN 47401
Project # 2015-14

Kirkwood Design Studio
113 East 6th Street
Bloomington, IN 47408
Attn: Mary Krupinski

Date: 10/31/2017

PR01 dated October 12, 2017 - ADD TO CONTRACT

Please accept the following as our proposal to furnish labor, equipment and supervision required to complete the above referenced project per plans and addenda submitted.

	Material	Labor	Subcontractor	Total
Revise price for landscaping due to City of Bloomington Planning Department review as shown on differences between the two Landscape Plans.				
Additional plants and trees			3958.00	3,958.00
Subcontractor Mark-up 5%				197.90
			Total	4,155.90

Add - 3 days to contract

Response By: Kent Kimmel
Larry Neidigh

Date of Response: 10/31/2017

Accepted by:

Date of Acceptance:

DRAFT AIA Document G709™ - 2001

Work Changes Proposal Request

PROJECT (Name and address):
COB Animal Care & Control Shelter
South Walnut
Bloomington, IN 47404

PROPOSAL REQUEST NUMBER: 001
DATE OF ISSUANCE: October 12, 2017

OWNER (Name and address):
City of Bloomington - Board of
Public Works
401 N. Morton Street
Bloomington, IN 47404

CONTRACT FOR: General Construction

CONTRACT DATE: March 7, 2017

FROM ARCHITECT (Name and address):
Kirkwood Design Studio, pc
113 East 6th Street
Bloomington, IN 47408

ARCHITECT'S PROJECT NUMBER:
2015-14

OWNER:	<input checked="" type="checkbox"/>
ARCHITECT:	<input checked="" type="checkbox"/>
CONSULTANT:	<input type="checkbox"/>
CONTRACTOR:	<input checked="" type="checkbox"/>
FIELD:	<input type="checkbox"/>
OTHER:	<input type="checkbox"/>

TO CONTRACTOR (Name and address):
Neidigh Construction Corporation
2220 W. Vernal Pike
Bloomington, IN 47404

Please submit an itemized proposal for changes in the Contract Sum and Contract Time for proposed modifications to the Contract Documents described herein. Within Zero (0) days, the Contractor must submit this proposal or notify the Architect, in writing, of the date on which proposal submission is anticipated.

THIS IS NOT A CHANGE ORDER, A CONSTRUCTION CHANGE DIRECTIVE OR A DIRECTION TO PROCEED WITH THE WORK DESCRIBED IN THE PROPOSED MODIFICATIONS.

DESCRIPTION (Insert a written description of the Work):

1. Revise price for landscaping due to City of Bloomington Planning Department review as shown on differences between the two Landscape Plans, attached.

ATTACHMENTS (List attached documents that support description):

Bynum Fanyo Original Landscape Drawing dated 1/10/17 and the revised Landscape Drawing with Revisions and dated 3/23/17.

REQUESTED BY THE ARCHITECT:

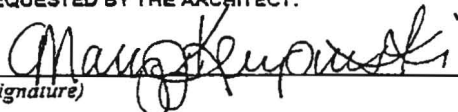
(Signature)

Mary J. Krupinski, Architect
(Printed name and title)

kkimmel@neidighconst.com

From: rabell@bluemarble.net
Sent: Friday, October 13, 2017 4:38 PM
To: kkimmel@neidighconst.com
Subject: RE: FW: ACCS - Proposal Request No1

From what I see there is an additional (11) 2 in. cal. Dogwood trees, (20) 3 gallon Blue Rug Junipers, and (17) 3 gallon Blue Star Junipers added to the planting list. Including Trees, shrubs, planting materials, installation and mulch the cost increase would be \$3958.00 Thanks Rob Abell Nursery

> See if this works for you

>

> -----Original Message-----

> From: rabell@bluemarble.net [mailto:rabell@bluemarble.net]

> Sent: Friday, October 13, 2017 2:20 PM

> To: kkimmel@neidighconst.com

> Subject: Re: FW: ACCS - Proposal Request No1

>

> Can you send this as a pdf so I can open it Thanks Rob Abell Nursery

>

>

>> Can you put a price to these changes

>>

>>

>>

>> From: Debbie Waymire [mailto:dwaymire@neidighconst.com]

>> Sent: Friday, October 13, 2017 12:09 PM

>> To: Kent Kimmel <kkimmel@neidighconst.com>

>> Subject: Fw: ACCS - Proposal Request No1

>>

>>

>>

>>

>>

>>

>>

>> From: Mary Krupinski

>>

>> Sent: Thursday, October 12, 2017 7:11 PM

>>

>> To: kkimmel@neidighconst.com <mailto:kkimmel@neidighconst.com> ;

>> 'Debbie Waymire'

>>

>> Cc: Virgil Sauder ; 'Jeff Fanyo'

>>

>> Subject: RE: ACCS - Proposal Request No1

>>

CHANGE REQUEST / ESTIMATE #10

CONTRACTOR: Neidigh Construction Corporation
ADDRESS: 2220 West Vernal Pike
 Bloomington, IN 47404
Tel: (812) 334-0362 **Fax:** (812) 334-3144

JOB: Animal Care & Control Shelter
 3410 S. Walnut Street
 Bloomington, IN 47401
 Project # 2015-14

Kirkwood Design Studio
 113 East 6th Street
 Bloomington, IN 47408
 Attn: Mary Krupinski

Date: 12/13/2017

ADD TO CONTRACT

Please accept the following as our proposal to furnish labor, equipment and supervision required to complete the above referenced project per plans and addenda submitted.

		Material	Labor	Subcontractor	Total
Adding Sally Port Utility Heater					
Gas lines				600.00	600.00
Heater				3100.00	3,100.00
Electrical				774.00	774.00
Project Management	3 hrs @	65.00		195.00	195.00
Administrative	1 hrs @	35.00		35.00	35.00
				230.00	4,704.00
Subcontractor Mark-up 5%					223.70
Labor - Mark-up 15%					34.50
				Total	4,962.20

Add -5 days to contract

Response By: Kent Kimmel
 Larry Neidigh

Date of Response: 12/13/2017

Accepted by:

Date of Acceptance:

SOUTHERN INDIANA MAINTENANCE, LLC
P.O. BOX 2207
Bloomington, IN 47402 US
812-279-0766
bradnicholson3@gmail.com

Estimate

NEIDIGH CONSTRUCTION
2220 W. VERNAL PIKE
BLOOMINGTON, IN 47404

1021 10/25/2017 11/25/2017

ANIMAL CARE CENTER	1	0.00	0.00
Service	1	1,200.00	1,200.00
PRICE IS FOR ADDING GAS LINE TO DRYER			
Service	1	600.00	600.00
PRICE IS FOR ADDING GAS LINE TO SALLY PORT HEATER			
		TOTAL	\$1,800.00

Accepted By

Accepted Date

31-Oct-17

GAYLOR

Proposal: Adding 120V Circuit for Sally Port Heater

Dear: Kent Kimmel

Gaylor Inc. proposes to make the electrical installation and or revisions:

In accordance with the plans or preliminary information available prior to our estimate, dated or on: 31-Oct-17

Included with our proposal is the attached electrical scope.

For a total of: **\$774.00**

Major packages will be ordered on acceptance of this proposal and approved submittals. Work will be scheduled in accordance with your intended completion date. Should you have any questions regarding our proposal, please feel free to call. Thank you for your consideration of Gaylor. We look forward to meeting your electrical needs.

Sincerely,
Gaylor Inc.

Jon Endris
Project Manager

PROPOSAL ACCEPTANCE:
 ACCEPTED IN THE SUM OF: _____ THIS _____ DAY
 OF _____, 20_____
 FOR _____ BY _____
 COMPANY NAME AUTHORITY NAME / TITLE

NOTE: THIS PROPOSAL IS VALID FOR 30 DAYS FROM PROPOSAL DATE PLEASE SIGN AND RETURN - RETAIN A COPY FOR YOUR FILES

GAYLOR INC
1636 State Street, Suite D

Columbus, IN 47201

12) 378-4145 fax (812) 378-4146

Page 2
31-Oct-17
7

SCOPE OF WORK FOR:

Providing and Installing Material

Alterations, Specifications, Remarks, Exceptions are as follows:

MATERIAL	\$123.66
SALES TAX	\$8.66
MATERIAL TOTAL	\$132.32
LABOR	\$571.00
LIFT RENTAL	\$0.00
SUBCONTRACT	\$0.00
TOTAL COST	\$703.32
Mark-up (10%)	\$70.33
SUB TOTAL	\$773.65
GRAND TOTAL	\$774



Heating & Air Conditioning

www.air-masterheatingandair.com
701 I Street
Bedford, IN 47421
(812) 279-0509

Change orders needed for animal care and control center

All changes listed will not be completed unless accepted

- 1.) Sally Port Unitary Heater (REZNOR brand) - \$3100.00
- 2.) Duct work return needed for rooms A126-129 - \$3520.00
- 3.) Booster fan and associated work for dryer vent - \$2000.00

Work excluded:

- Gas line
- Electrical
- Drains

Any and all change orders will be completed asap as soon as it is issued. All change orders to be modified on Air-Master's original contract with Neidigh Construction.

For any questions or concerns please call Tyler Lewis at 812-279-0509

CHANGE REQUEST / ESTIMATE #11

CONTRACTOR: Neldigh Construction Corporation
ADDRESS: 2220 West Vernal Pike
 Bloomington, IN 47404
Tel: (812) 334-0362 **Fax:** (812) 334-3144

JOB: Animal Care & Control Shelter
 3410 S. Walnut Street
 Bloomington, IN 47401
 Project # 2015-14

Kirkwood Design Studio
 113 East 6th Street
 Bloomington, IN 47408
 Attn: Mary Krupinski

Date: 12/13/2017

PR #2 dated October 12, 2017 - ADD TO CONTRACT

Please accept the following as our proposal to furnish labor, equipment and supervision required to complete the above referenced project per plans and addenda submitted.

	Material	Labor	Subcontractor	Total
#1 - Replace the previously scheduled faucets for the stainless steel sinks at the Tray Clean A104 and the Bowl Clean A105 with - Similar to T & S Model MPA-8WLN-06				
Faucets for Rooms 104 & A105			958.06	958.06
#2 - Replace the previously scheduled faucet for the Dog Wash station in Grooming A120 with the following Similar to T & S Model P3-8WOSN06PZLUA				
Faucets for A120			487.28	487.28
Project Management	1 hrs @	65.00	65.00	65.00
Administrative	1 hrs @	35.00	35.00	35.00
			100.00	1,545.34
Subcontractor Mark-up 5%				72.27
Labor - Mark-up 15%				15.00
			Total	1,832.61

Response By: Kent Kimmel
 Larry Neldigh

Date of Response: 12/13/2017

Accepted by:

Date of Acceptance:

DRAFT AIA Document G709™ - 2001

Work Changes Proposal Request

PROJECT (Name and address):
COB Animal Care & Control Shelter
South Walnut
Bloomington, IN 47404

PROPOSAL REQUEST NUMBER: 002

DATE OF ISSUANCE: October 12, 2017

OWNER (Name and address):
City of Bloomington - Board of
Public Works
401 N. Morton Street
Bloomington, IN 47404

CONTRACT FOR: General Construction

CONTRACT DATE: March 7, 2017

FROM ARCHITECT (Name and address):
Kirkwood Design Studio, pc
113 East 6th Street
Bloomington, IN 47408

ARCHITECT'S PROJECT NUMBER: 2015-14

TO CONTRACTOR (Name and address):
Neidigh Construction Corporation
2220 W. Vernal Pike
Bloomington, IN 47404

OWNER:	<input checked="" type="checkbox"/>
ARCHITECT:	<input checked="" type="checkbox"/>
CONSULTANT:	<input type="checkbox"/>
CONTRACTOR:	<input checked="" type="checkbox"/>
FIELD:	<input type="checkbox"/>
OTHER:	<input type="checkbox"/>

Please submit an itemized proposal for changes in the Contract Sum and Contract Time for proposed modifications to the Contract Documents described herein. Within Zero (0) days, the Contractor must submit this proposal or notify the Architect, in writing, of the date on which proposal submission is anticipated.

THIS IS NOT A CHANGE ORDER, A CONSTRUCTION CHANGE DIRECTIVE OR A DIRECTION TO PROCEED WITH THE WORK DESCRIBED IN THE PROPOSED MODIFICATIONS.

DESCRIPTION (Insert a written description of the Work):

1. Replace the previously scheduled faucets for the stainless steel sinks at the Tray Clean A 104 and the Bowl Clean A105 with the following: Similar to T&S Model MPZ-8WLN-06
2. Replace the previously scheduled faucet for the Dog Wash station in Grooming A120 with the following: Similar to T&S Model P3-8WOSN06PZLUA

ATTACHMENTS (List attached documents that support description):

T&S Cut Sheets (2) for above noted faucets.

REQUESTED BY THE ARCHITECT:

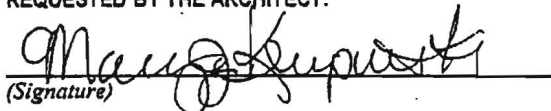
(Signature)

Mary J. Krupinski, Architect
(Printed name and title)



T&S BRASS AND BRONZE WORKS, INC.

2 Saddleback Cove / P.O. Box 1088
Travelers Rest, SC 29690

Model No.

MPZ-8WLN-06

Item No.

Travelers Rest, SC: 800-476-4103 • Simi Valley, CA: 800-423-0150 • Fax: 864-834-3518 • www.tsbrass.com

This Space for Architect/Engineer Approval

Job Name _____ Date _____

Model Specified _____ Quantity _____

Customer/Wholesaler _____

Contractor _____

Architect/Engineer _____

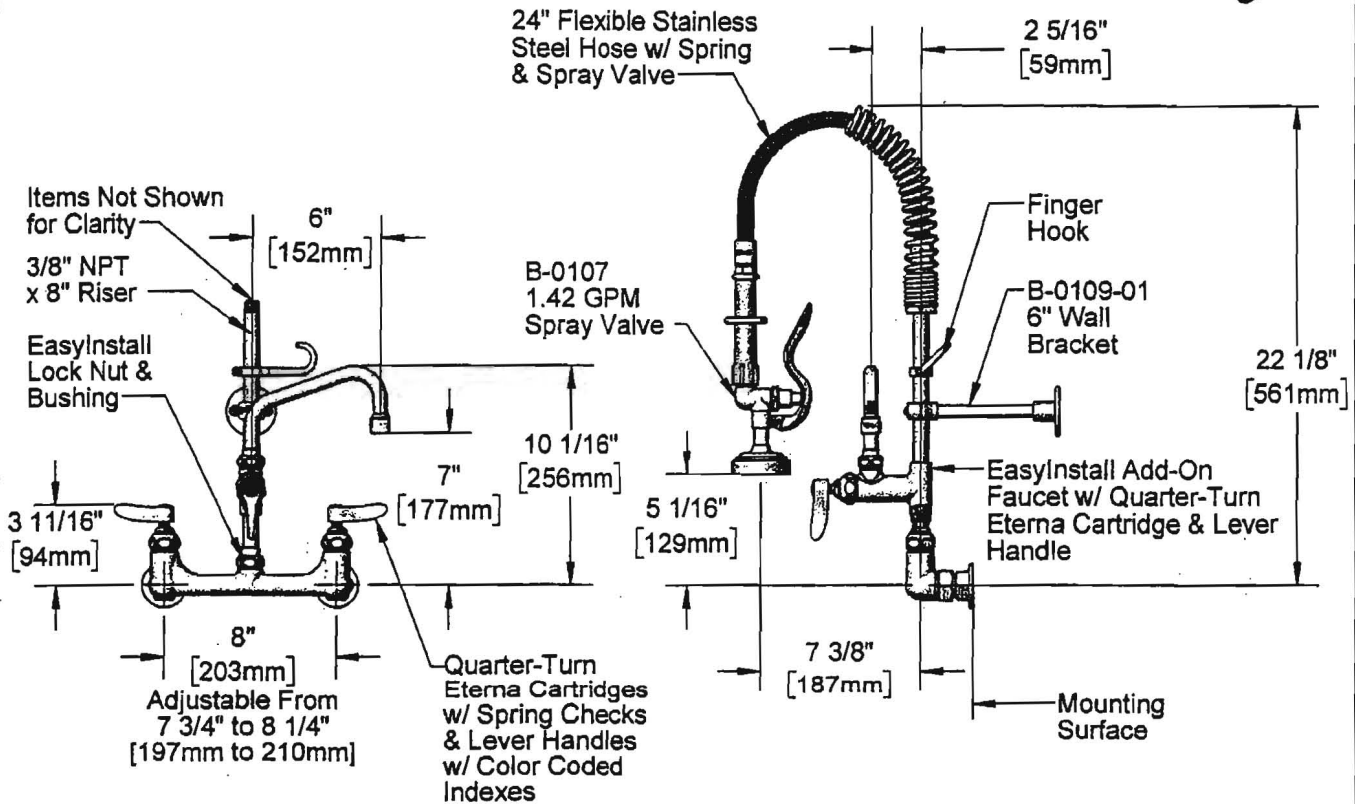
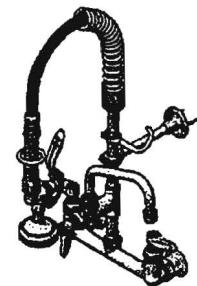
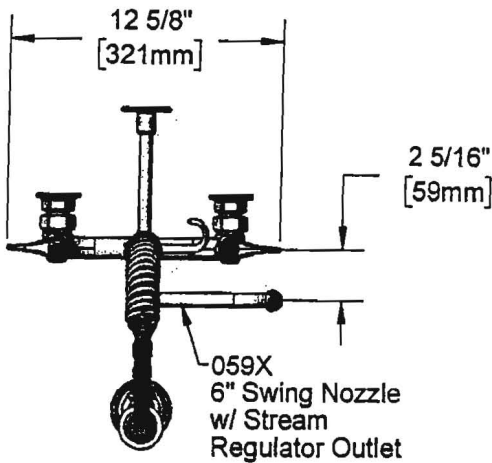

Product Specifications:

Pre-Rinse Unit: EasyInstall 8" Wall Mount Mixing Faucet, Quarter-Turn Eterna Cartridges w/ Spring Checks, Lever Handles, Add-On Faucet w/ 6" Swing Nozzle, Compact Spring, 24" Flexible Stainless Steel Hose, 1.42 GPM Spray Valve, 6" Wall Bracket & 1/2" NPT Female Inlets

Product Compliance:

ASME A112.18.1 / CSA B125.1
NSF 61 - Section 9
NSF 372 (Low Lead Content)
EPA Act 2005 (PRSV)
For Commercial Use Only



T&S BRASS AND BRONZE WORKS, INC.

2 Saddleback Cove / P.O. Box 1088
Travelers Rest, SC 29690

Model No.

MPZ-8WLN-06

Item No.

Travelers Rest, SC: 800-476-4103 • Simi Valley, CA: 800-423-0150 • Fax: 864-834-3518 • www.tsbrass.com

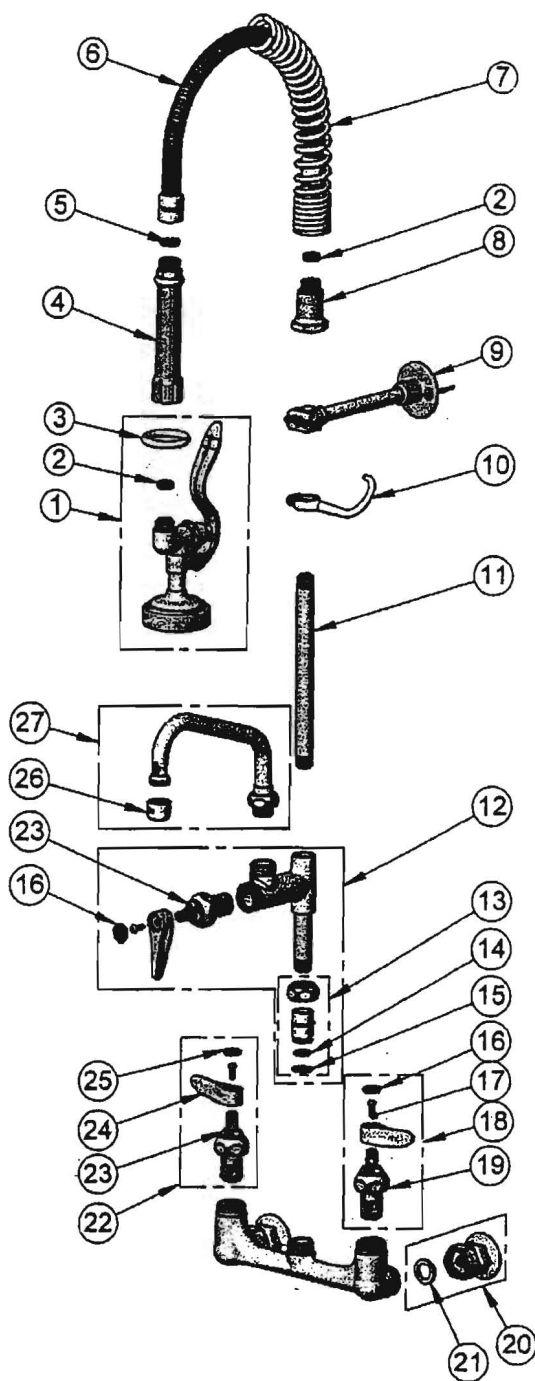

ITEM NO.	SALES NO.	DESCRIPTION
1	B-0107	1.42 GPM Spray Valve
2	010476-45	#27 Washer
3	000907-45	Spray Valve Hold Down Ring
4	002987-40	Grip Handle
5	001014-45	Washer, B-0100 Hose Barrel
6	B-0024-H2A	24" Flexible Stainless Steel Hose, Less Handle
7	016795-45	Compact Spring
8	000821-40	Spring Body
9	B-0109-01	6" Wall Bracket
10	004R	Finger Hook
11	078X	3/8" NPT x 8" Riser
12	B-0155-LNEZ	EasyInstall Add-On Faucet w/ Quarter-Turn Eterna Cartridge & Lever Handle, Less Nozzle
13	EZ-K	EasyInstall Kit: Nut, Bushing, O-Ring & Lock Washer
14	001065-45	O-Ring
15	014200-45	Star Washer, Anti-Rotation
16	018506-19NS	Blue Button Index, Press-in
17	000925-45	Lab Handle Screw
18	002711-40NS	Quarter-Turn Eterna Cartridge, LTC w/ Spring Check, Handle, Index & Screw
19	012442-40NS	Quarter-Turn Eterna Cartridge, LTC w/ Spring Check
20	00AA	1/2" NPT Female Eccentric Flange
21	001019-45	Coupling Nut Washer
22	002712-40NS	Quarter-Turn Eterna Cartridge, RTC w/ Spring Check, Handle, Index & Screw
23	012443-40NS	Quarter-Turn Eterna Cartridge, RTC w/ Spring Check
24	001638-45NS	Lever Handle (New Style)
25	001193-19NS	Red Button Index, Press-in
26	B-PT	Full Flow Stream Regulator, 55/64-27
27	059X	6" Swing Nozzle w/ Stream Regulator Outlet

Product Specifications:

Pre-Rinse Unit: EasyInstall 8" Wall Mount Mixing Faucet, Quarter-Turn Eterna Cartridges w/ Spring Checks, Lever Handles, Add-On Faucet w/ 6" Swing Nozzle, Compact Spring, 24" Flexible Stainless Steel Hose, 1.42 GPM Spray Valve, 6" Wall Bracket & 1/2" NPT Female Inlets

Product Compliance:

ASME A112.18.1 / CSA B125.1
NSF 61 - Section 9
NSF 372 (Low Lead Content)
EPA Act 2005 (PRSV)
For Commercial Use Only



T&S BRASS AND BRONZE WORKS, INC.
 2 Saddleback Cove / P.O. Box 1088
 Travelers Rest, SC 29690

Model No.
P3-8WOSN06PZLUA
 Item No.

Travelers Rest, SC: 800-476-4103 • Simi Valley, CA: 800-423-0150 • Fax: 864-834-3518 • www.tsbrass.com

This Space for Architect/Engineer Approval

Job Name _____ Date _____
 Model Specified _____ Quantity _____
 Customer/Wholesaler _____
 Contractor _____
 Architect/Engineer _____

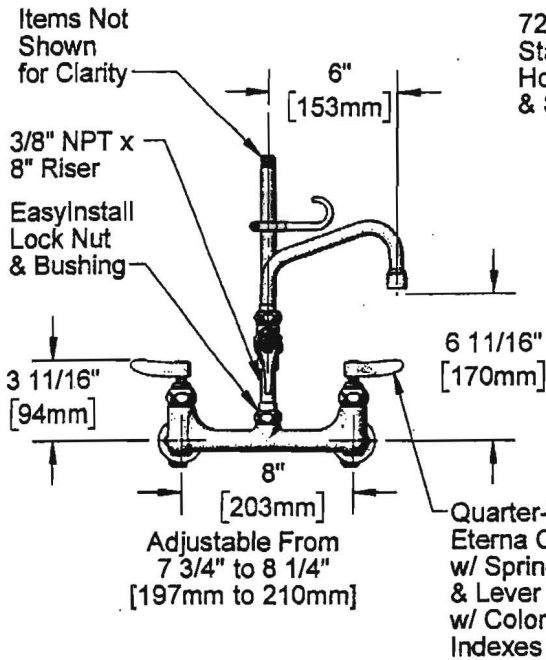
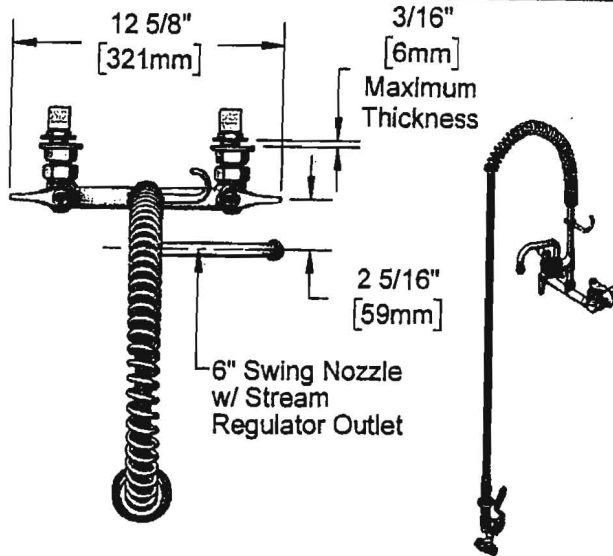

72" Flexible Stainless Steel Hose w/ Spring & Spray Valve

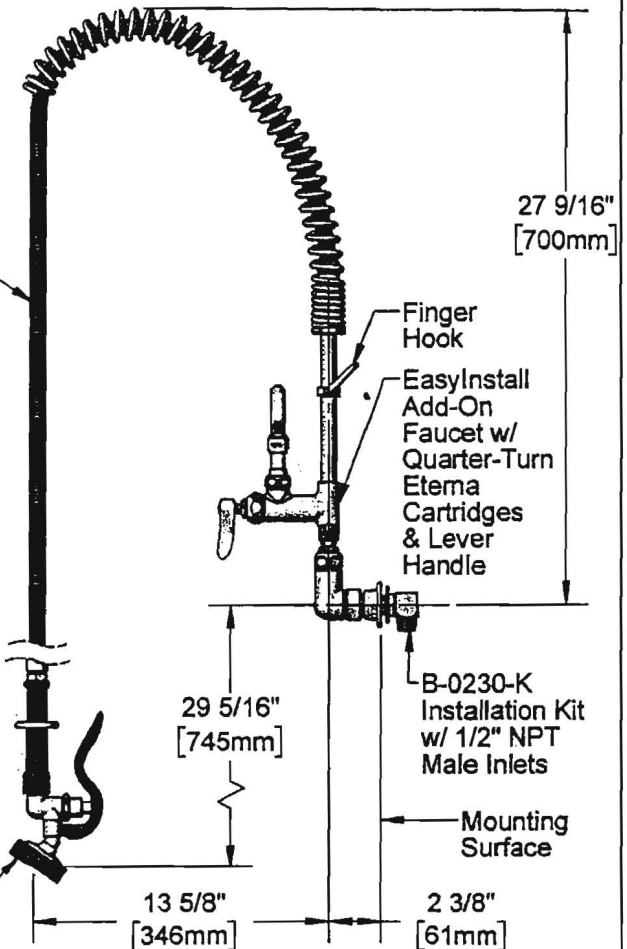

Product Specifications:

Pre-Rinse Unit: EasyInstall 8" Wall-Mount Mixing Faucet, Quarter-Turn-Eterna Cartridges w/ Spring Checks, Lever Handles, Add-On Faucet, 6" Swing Nozzle, 8" Riser, 72" Flexible Stainless Steel Hose, High Flow Angled Spray Valve (Blue) & Installation Kit w/ 1/2" NPT Male Inlets

Product Compliance:

ASME A112.18.17 CSA B125.1
 NSF 61 Exempt (Non-Potable)
 NSF 372 (Low Lead Content)
 EPA 2005 Non-Compliant (PRSV)



T&S BRASS AND BRONZE WORKS, INC.

2 Saddleback Cove / P.O. Box 1088
Travelers Rest, SC 29690

Model No.

P3-8WOSN06PZLUA

Item No.

Travelers Rest, SC: 800-476-4103 • Simi Valley, CA: 800-423-0150 • Fax: 864-834-3518 • www.tsbrass.com

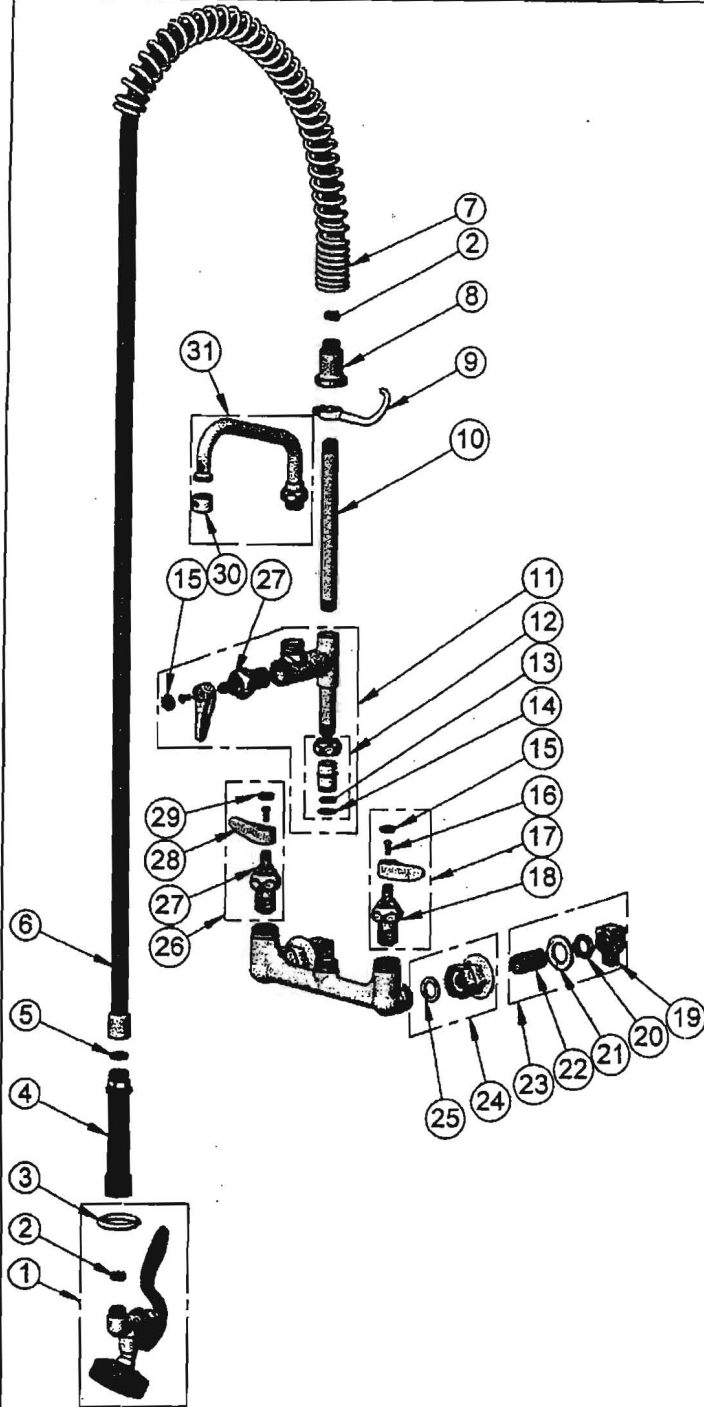

ITEM NO.	SALES NO.	DESCRIPTION
1	B-0107	1.42 GPM Spray Valve
2	010476-45	#27 Washer
3	000907-45	Spray Valve Hold Down Ring
4	011482-45	Blue Grip Handle
5	001014-45	Washer, B-0100 Hose Barrel
6	B-0072-H2A	72" Flexible Stainless Steel Hose, Less Handle
7	000888-45	EasyInstall Overhead Spring
8	000821-40	Spring Body
9	004R	Finger Hook
10	000364-40	Nipple, 3/8" NPT x 8"
11	B-0155-LNEZ	EasyInstall Add-On Faucet w/ Quarter Turn Eterna Cartridge, RTC & Lever Handle, Less Nozzle
12	EZ-K	EasyInstall Kit: Nut, Bushing, O-Ring & Lock Washer
13	001065-45	O-Ring
14	014200-45	Star Washer, Anti-Rotation
15	018506-19NS	Blue Button Index, Press-in
16	000925-45	Lab Handle Screw
17	002711-40NS	Quarter-Turn Eterna Cartridge, LTC w/ Spring Check, Handle, Index & Screw
18	012442-40NS	Quarter-Turn Eterna Cartridge, LTC w/ Spring Check
19	B-1100-K	1/2" NPT Male Inlet Elbow
20	002954-45	Shank Lock Nut
21	000999-45	Brass Lock Washer
22	013357-20	1/2" NPT x 1 5/8" Close Nipple
23	B-0230-K	Short Elbow Installation Kit
24	00AA	1/2" NPT Female Eccentric Flange
25	001019-45	Coupling Nut Washer
26	002712-40NS	Quarter-Turn Eterna Cartridge, RTC w/ Spring Check, Handle, Index & Screw
27	012443-40NS	Quarter-Turn Eterna Cartridge, RTC w/ Spring Check
28	001638-45NS	Lever Handle (New Style)
29	001193-19NS	Red Button Index, Press-in
30	B-PT	Full Flow Stream Regulator, 55/64-27
31	059X	6" Swing Nozzle w/ Stream Regulator Outlet

Product Specifications:

Pre Rinse Unit, EasyInstall 8" Wall Mount Mixing Faucet, Quarter-Turn Eterna Cartridges w/ Spring Checks, Lever Handles, Add-On Faucet, 6" Swing Nozzle, 8" Riser, 72" Flexible Stainless Steel Hose, High Flow Angled Spray Valve (Blue) & Installation Kit w/ 1/2" NPT Male Inlets

Product Compliance:

ASME A112.18.17 CSA B125.1
NSF 61 Exempt (Non-Potable)
NSF 372 (Low Lead Content)
EPA 2005 Non-Compliant (PRSV)

SOUTHERN INDIANA MAINTENANCE, LLC
P.O. BOX 2207
Bloomington, IN 47402 US
812-279-0766
bradnicholson3@gmail.com

Estimate

NEIDIGH CONSTRUCTION
2220 W. VERNAL PIKE
BLOOMINGTON, IN 47404

1015 10/16/2017

Service	1	958.06	958.06
ANIMAL CENTER FAUCETS FOR ROOM A-104 AND A-105			
Service	1	487.28	487.28
FAUCETS FOR ROOM A-120			
	TOTAL		\$1,445.34

Accepted By

Accepted Date

CHANGE REQUEST / ESTIMATE #12

CONTRACTOR: Neidigh Construction Corporation
 ADDRESS: 2220 West Vernal Pike
 Bloomington, IN 47404
 Tel: (812) 334-0362 Fax: (812) 334-3144

JOB: Animal Care & Control Shelter
 3410 S. Walnut Street
 Bloomington, IN 47401
 Project # 2015-14

Kirkwood Design Studio
 113 East 6th Street
 Bloomington, IN 47408
 Attn: Mary Krupinski

Date: 12/13/2017

ADD TO CONTRACT

Please accept the following as our proposal to furnish labor, equipment and supervision required to complete the above referenced project per plans and addenda submitted.

	Material	Labor	Subcontractor	Total
Add sprinkler to vestibule				
Sprinkler pipe and heads			4780.00	4,780.00
Project Management	2 hrs @ 65.00	130.00		130.00
Administrative	1 hrs @ 35.00	35.00		35.00
		165.00	4780.00	4,945.00
Subcontractor Mark-up 5%				239.00
Labor - Mark-up 15%				24.75
			Total	5,208.75

Add - 3 days to contract

Response By: Kent Kimmel
 Larry Neidigh

Date of Response: 12/13/2017

Accepted by:

Date of Acceptance:

October 25, 2017



PROJECT: Bloomington Animal Care & Control
Reference: Fire Protection Bid

Dalmatian Fire, Inc. offers a firm price quote in the amount of **FOUR THOUSAND SEVEN HUNDRED & EIGHTY DOLLARS (4,780.00)** to extend the new wet fire suppression system into the front entry way.

SCOPE OF WORK

1. Extend the new wet type fire suppression system into the front entry ways A100, B126 and the two rooms to the south.
2. We will also install dry pendant side wall sprinkler heads under the canopy in the front and under the metal soffit in the back.
3. We will need to add upright sprinkler heads above the acoustical ceiling per code do to wood construction.
4. We assume that all areas above the ceiling will be NON freezing condition.
5. We assume that all work will be done under normal working hours Monday thru Friday 7am to 330pm No weekend or holiday work included.

Our proposal includes material, design, and labor. We exclude any painting of pipe and electrical wiring.

Thank you for considering Dalmatian Fire Inc. for your fire protection needs. If you have any questions regarding this project or our scope of work, please do not hesitate to call.

Respectfully,

Brian Funkhouser
Service Manager

5670 West 73rd Street
Indianapolis, IN 46278
317.299.3889
317.299.4078 fax

DRAFT AIA® Document G701™ - 2001

Change Order

PROJECT (Name and address):

City of Bloomington-
Board of Public Works
401 N. Morton Street, suite 120
Bloomington, IN 47404

TO CONTRACTOR (Name and address):

Neidigh Construction Corporation
2220 W. Vernal Pike
Bloomington, IN 47404

CHANGE ORDER NUMBER: 004 FINAL

DATE: March 1, 2018

ARCHITECT'S PROJECT NUMBER: 2015-14

CONTRACT DATE: March 7, 2017

CONTRACT FOR: General Construction

OWNER:

ARCHITECT:

CONTRACTOR:

FIELD:

OTHER:

THE CONTRACT IS CHANGED AS FOLLOWS:

(Include, where applicable, any undisputed amount attributable to previously executed Construction Change Directives)

1. Reroof the existing facility due to unforeseen conditions.....Add \$28,388.61

TOTAL AMOUNT THIS CHANGE ORDER NO. 4\$28,388.61

The original Contract Sum was

The net change by previously authorized Change Orders

The Contract Sum prior to this Change Order was

The Contract Sum will be increased by this Change Order in the amount of

The new Contract Sum including this Change Order will be

\$	1,940,011.00
\$	74,463.08
\$	2,014,474.08
\$	28,388.61
\$	<u>2,042,862.69</u>

The Contract Time will be increased by ten work days (10 work) days.

The date of Substantial Completion as of the date of this Change Order therefore is changed from January 31, 2018 to March 29, 2018.

NOTE: This Change Order does not include changes in the Contract Sum, Contract Time or Guaranteed Maximum Price which have been authorized by Construction Change Directive until the cost and time have been agreed upon by both the Owner and Contractor, in which case a Change Order is executed to supersede the Construction Change Directive.

NOT VALID UNTIL SIGNED BY THE ARCHITECT, CONTRACTOR AND OWNER.

Kirkwood Design Studio, PC

ARCHITECT (Firm name)

113 East 6th Street
Bloomington, IN 47408

ADDRESS

BY (Signature)

Mary J. Krupinski, AIA, President

(Typed name)

March 1, 2018

DATE

Neidigh Construction Corporation

CONTRACTOR (Firm name)

2220 West Vernal Pike
Bloomington, IN 47404

ADDRESS

BY (Signature)

(Typed name)

DATE

City of Bloomington-
Board of Public Works

OWNER (Firm name)

401 N. Morton Street
Bloomington, IN 47404

ADDRESS

BY (Signature)

(Typed name)

DATE

CHANGE REQUEST / ESTIMATE #16

CONTRACTOR: Neidigh Construction Corporation
ADDRESS: 2220 West Vernal Pike
 Bloomington, IN 47404
Tel: (812) 334-0362 **Fax:** (812) 334-3144

JOB: Animal Care & Control Shelter
 3410 S. Walnut Street
 Bloomington, IN 47401
 Project # 2015-14

Kirkwood Design Studio
 113 East 6th Street
 Bloomington, IN 47408
 Attn: Mary Krupinski

Date: 2/27/2018

ADD TO CONTRACT

Please accept the following as our proposal to furnish labor, equipment and supervision required to complete the above referenced project per plans and addenda submitted.

		Material	Labor	Subcontractor	Total
Option 1 - reroofing existing building					
Excludes: gutters, downspouts, and fascia.					
Project Management	1 hrs @	65.00	65.00		65.00
Administrative	1 hrs @	35.00	35.00		35.00
		6892.00	15672.75	5875.00	28,439.75
Subcontractor - Mark up 5%					293.75
Material - Mark-up 10%					689.20
Labor - Mark-up 15%					2,365.91
Total					31,888.61

Add - 2 weeks to contract

minus credit for roof replacement w/in project -3500.⁰⁰

FINAL COST 28,388.⁶¹

Response By: Kent Kimmel
 Larry Neldigh

Date of Response: 02/27/2018

Accepted by:

Date of Acceptance:

City of Bloomington
Redevelopment Commission
AMENDED Project Review & Approval Form

Please Note:

- Approval of the project by the Redevelopment Commission through this Project Review & Approval Form does not represent an authorization to begin work or expend funds.
- Authorization of work and the commitment of funds shall be done when the Redevelopment Commission reviews and approves: (1) a Purchase Order or Contract prepared after complying with the appropriate procurement process for the type of item, service or construction being sought and (2) the estimated costs associated with the Purchase Order or Contract.
- No payment of funds shall be made without a duly authorized and approved Purchase Order or Contract. All claims for payment against a duly authorized Purchase Order or Contract shall be submitted to the Redevelopment Commission for their review and approval along with any required departmental inspections, reviews and approvals prior to the payment of any funds.

To Be Completed by Requesting Party:

Project Name: Bloomington Animal Shelter Addition/Renovation

Project Managers: Adam Wason and Virgil Sauder

Project Description:

The City of Bloomington is a leader in the animal care and control industry, which speaks to the nature and character of the community. Often, when new Bloomington residents come into the Shelter, they are blown away by the staff, environment, and the healthy pets available for adoption. Over the last decade we have reduced euthanasia by 59%, increased adoptions by 25%, and reduced the total number of animals entering the system by 23%. For us to continue this type of success we must upgrade the Shelter.

In 2011, a building analysis and planning study was completed for the Shelter. (A copy of that study is attached to this Project Review and Approval Form.) The study's goal was to recommend renovations and additions that would allow the existing facility to provide "a solid basis for service into the next two decades."

In conducting that review, the consultant concluded that the numerous issues with the 1970s era portion of the shelter—including issues with the lighting, drainage, and HVAC—would require significant renovation in order to properly support the sheltered animals in a healthy environment, and that the cost of renovations would likely exceed the value of the entire building.¹

¹ The study also noted inherently unworkable traffic patterns caused by the 1970s building and the 2004 expansion, which could not be resolved by a renovation.

This project would demolish the 1970s era portion of the shelter (which is currently used as the dog kennel area, Monroe County Humane Association Offices, Euthanasia Room, and Special Care Cat Room), reuse the 2004 expansion, and develop a new addition to accommodate the Shelter’s current and projected future needs. This will both increase the Shelter’s ability to properly care for the animals entering the Shelter and create a safe environment for the thousands of guests that enter the Shelter each year.

This project is a permissible use of Tax Increment. Although the starting point is an existing building, the scope of the project is more akin to new construction. If the TIF Test applied, all four factors would be satisfied:

1. It is substantial and complex work that involves the addition of new parts.
2. It will directly increase the value of the Shelter, replacing an old, flawed building with a new building sufficient for the next two decades.
3. The Shelter after the completion of the project will perform as well as a newly constructed Shelter.
4. This project—demolition and new construction—was not contemplated as part of the normal life cycle of the existing Shelter.

Additionally, this is a project that would be capitalized under the IRS’s guidelines.

Project Timeline:

Start Date: September 2015
End Date: October 2018

Financial Information:

Estimated full cost of project:	2,268,466.90
Sources of funds:	TIF Bond or Consolidated TIF
Construction Change Order 2	\$15,000
Construction Change Order 3	\$18,029.46
Construction Change Order 4	\$28,388.61

Project Phases: This breakdown should mirror the contract(s) expected to be issued for this project. Each phase should include a description of the work to be performed, the cost, and the timeline for the contract.

<u>Phase / Work to be Performed</u>	<u>Cost</u>	<u>Timeline</u>
1. Design	\$213,850	September 2015-March 2017
2. Construction	\$2,041,862.69	March 2017-March 2018
3. Cat 6 Wiring and Fiber Optic Extension ²	\$31,660	December 2017-June 2018
4. Gate at Vehicular Entrance	\$20,000	March 2017-January 2018
5. Conduit Installation	\$2,750	May 2017-July 2017
6. Utility Relocation	\$4,762.28	July 2017 – September 2017

TIF District: Consolidated TIF (South Walnut)

Resolution History: 15-48 Original Project Review and Approval Form
15-99 Approval of Design Contract
17-19 Approval of Construction Contract
17-40 Conduit Installation
17-44 Approval of Addendum to Design Contract
17-49 Utility Relocation
17-70 Approval of First Construction Change Order
17-97 Approval of Cat 6 Wiring and Fiber Optic Extension
18-11 Approval of Second Construction Change Order
18-19 Approval of Third and Fourth Change Orders

To Be Completed by Redevelopment Commission Staff:

Approved on _____

By Resolution _____ by a vote of _____

² The original expectation was that items 3 and 4 would be included in the Construction Bid. Staff now expects these will be separate contracts.