

CITY OF BLOOMINGTON



March 18, 2019 @ 5:30 p.m.
COUNCIL CHAMBERS #115
CITY HALL

**CITY OF BLOOMINGTON
PLAN COMMISSION
March 18, 2019 at 5:30 p.m.**

❖City Council Chambers – Room #115

ROLL CALL

MINUTES TO BE APPROVED: February 2019

REPORTS, RESOLUTIONS AND COMMUNICATIONS:

CONTINUED TO APRIL:

PUD-07-19 **Whitehall Crossing LLC**
402 N. Gates Drive
PUD final plan approval to allow the construction of a 4,000 sq. ft. retail store. Also requested is preliminary plat approval for a 2-lot subdivision.
Case Manager: Eric Greulich

***Note: Per PC Rules, a vote is needed to continue the following case. Staff has informed the petitioner that this is the last continuance that Staff would support.**

*SP-14-18 **Waterstone Bloomington Land LLC**
320 W. 11th Street
Site plan approval to allow a 52,720 sq. ft. mixed use building with 22 parking spaces.
Case Manager: Eric Greulich

CONSENT AGENDA:

PUD-38-18 **IU Credit Union**
4201 E. Hagan Street
Final plan approval for 13,284 sq. ft. office building.
Case Manager: Eric Greulich

PUD-06-19 **R&B Group Inc.**
2917 S. Mcintyre Drive
PUD final plan approval to allow the construction of a 10,000 sq. ft. building trade office
Case Manager: Eric Greulich

PETITIONS:

PUD-30-18 **Curry Urban Properties**
108 N. Pete Ellis Drive
Rezone real estate identified as Lot #8 located in Deckard E 3rd St. neighborhood subdivision, Monroe County, IN, consisting of 3.2 acres from CL to Planned Unit Development. Preliminary plan & district ordinance.
Case Manager: Eric Greulich

****Next Meeting April 8, 2019**

Last Updated: 3/15/2019

**Auxiliary aids for people with disabilities are available upon request with adequate notice.
Please call [812-349-3429](tel:812-349-3429) or e-mail human.rights@bloomington.in.gov.**

**BLOOMINGTON PLAN COMMISSION
STAFF REPORT
Location: 105 S. Pete Ellis Drive**

**CASE #: PUD-30-18
DATE: March 18, 2019**

PETITIONER: Curry Urban Properties
23579 E. Saddlebrook Lane Bloomington

CONSULTANTS: Michael L. Carmin, CarminParker, PC
116 W. 6th Street Suite 200, Bloomington

REQUEST: The petitioner is requesting a rezone from Commercial Limited (CL) to Planned Unit Development (PUD) and approval of a Preliminary Plan and District Ordinance. Also requested is a waiver from the required 5 acre minimum for a Planned Unit Development.

BACKGROUND:

Area: 3.2 acres
Current Zoning: Commercial Limited
GPP Designation: Regional Activity Center / edge of Focus Area
Existing Land Use: Undeveloped
Proposed Land Use: Dwelling, Multi-Family / Commercial / Business/Professional Office
Surrounding Uses: North – Dwelling, Multi-Family
 West – Vacant / Place of Worship
 East – Commercial
 South – Dwelling, Multi-Family

CHANGES SINCE FIRST HEARING: This petition was last heard at the November 5, 2018 Plan Commission Hearing. At that meeting, the Department sought comments regarding the massing of the proposed building, the amount of proposed of green space, and the possible public benefits being offered by the project. The Department has been working with the petitioner on the appropriate building bulk and design, green and innovative design incorporation, and incorporating a diverse housing mixture.

The petitioner has submitted a revised petitioner statement in response to comments from the Plan Commission and the Department that responds to the issues raised at the hearing. The revised statement addresses possible impacts to the multi-family apartments to the north, overall building massing, the proposed amount of open space and impervious surface coverage, bicycle and pedestrian safety concerns along Pete Ellis Drive, the proposed density, and 2 options for providing a diverse housing component.

Specific changes include-

- A total of 12 units have been removed from the proposal since the first hearing as a result of increasing the proposed building setback from 7' to 15' from the north property line.
- Back-out angled spaces have been shown along Pete Ellis Drive to address traffic concerns.
- Balconies were removed from the north façade facing the adjacent multi-family units.
- Total proposed open space has increased from 25% to 31%.

- Commitment to widen adjacent multi-use paths along 7th Street and Longview Drive from 8' to 12' wide.

REPORT: The property is located at the northwest corner of E. Longview Avenue and S. Pete Ellis Drive and is zoned Commercial Limited (CL). The 3.2 acre property is currently undeveloped. Surrounding zoning includes Residential High Density Multifamily (RH) to the north, Residential High Density Multifamily (RH) and Commercial Limited (CL) to the south, and Commercial Limited (CL) to the east and west. The surrounding properties have been developed with a mix of high density multi-family residences and commercial tenant spaces with the St. Mark United Methodist Church just to the west of the site. This property has frontage on 3 public streets- E. 7th Street to the west, E. Longview Drive to the south, and S. Pete Ellis Drive to the east. There are no environmental constraints on this property.

The petitioner proposes to create a Planned Unit Development in order to construct a 4-story, mixed-use building. The proposal includes a minimum of 12,000 square feet of commercial space with apartments on the upper floor and a portion of the ground floor. The commercial use is expected to be medical office related to the new hospital campus. The multifamily portion of the proposal includes a mix of studio units, one-bedroom units, and two-bedroom units for a possible total of 280 units and 360 bedrooms. The overall density is proposed at a maximum of 30 units/acre. The building will also contain structured parking garage accessed from Longview Drive with 306 parking spaces. The proposed maximum parking ratio is 0.90 spaces per unit and no more than 0.70 spaces per bed, however some of the 306 parking spaces will be used for the commercial use. The structured parking will be for the office portion of the building, as well as for the residential tenants. The petitioner also proposes 16 back-in, angled, on-street spaces on Pete Ellis Drive.

COMPREHENSIVE PLAN: This property is designated as *Regional Activity Center* in the southeast corner of the *Regional Academic Health Center Focus Area*. The Comprehensive Plan notes the following about the intent of the *Regional Activity Center* area:

- ...district is a large commercial area that provides high intensity retail activity
- Regional Activity Centers contain higher intensity uses such as national retailers, offices, food services, lodging, and entertainment.
- The district may also incorporate medium- to high-density multifamily residential uses.
- The main purpose of the district is to provide semi-urban activity centers that complement, rather than compete with, the Downtown district.
- The district is expected to change with increasing activity through infill and redevelopment.
- Incorporating multifamily residential within the district is supported.
- Changing the context of the district towards mixed use is a significant change.
- Less intense commercial uses should be developed adjacent to residential areas to buffer the impacts of such development. Multifamily residential and office uses could likewise serve as transitional elements.
- Redevelopment within the district should be encouraged to grow vertically, with the possibility of two- or three-story buildings to accommodate denser office development, residential multifamily, structures parking, and improved multimodal connectivity.

The Comprehensive Plan notes the following about the *Regional Academic Health Center Focus Area*:

- The relocation of the hospital onto the Indiana University campus will allow for the hospital to grow and meet the needs of the region. However, there are many ancillary support services, businesses, and medical offices that also may relocate near the hospital.

The development of this three acre parcel will add mixed use with office and multifamily residential to a portion of the Regional Activity Center that is not on the main commercial thoroughfare. The project will include mixed uses with a building forward design and improvements to the adjacent pedestrian facilities. The proposed Preliminary Plan is consistent with most of the intent and development guidance of the Comprehensive Plan for this area. However, the size and massing of the building are larger than the Comprehensive Plan guidance suggests.

PRELIMINARY PLAN:

Uses/Development Standards: The petitioner is proposing to utilize the Commercial Limited (CL) zoning district for the permitted uses and development standards for this project. The deviations from the CL district include requesting to allow first-floor residential uses and the removal of the maximum square footage limitation that exists in CL for a single tenant, which is currently limited to 5,000 square feet per tenant. Other deviations requested from the CL district include an increase in allowable density, building height, and impervious surface coverage. The project will meet all other development standards for the CL district. Architecture standards are addressed separately in this report.

Residential Density: The maximum residential density allowed in the CL district is 15 units per acre, which is the densest by-right development allowed in the UDO outside of the downtown. The petitioner is proposing a maximum of 30 units per acre for the PUD. The proposed density is double that of the currently allowed density. The petitioner is proposing a possible number of 280 units with 360 bedrooms. The Comprehensive Plan calls for medium- to high-density multifamily residential in the *Regional Activity Center* designation.

Height and Bulk: The petitioners are proposing one, four-story building to be articulated to appear as multiple buildings through the use of varying architectural materials, building recesses, and setbacks along the facades. While the building will mostly be four-stories, because of the grade change on the lot, the southwest corner will have a partial basement level that will be visible, which will create five stories at the corner module. The CL zoning district has a maximum height of 40 feet. At its tallest point the building is proposed to be 61' tall. The petitioner has addressed concerns regarding bulk and massing by increasing the proposed setback from the north property line and through the use of modulation around the building. A review by the Department has found that the proposed massing is adequately mitigated by the proposed modulations and articulations. Portions of the upper floors are recessed to address massing concerns.

Parking, Streetscape, and Access: The property has frontage on 7th Street, Longview Avenue, and Pete Ellis Drive. A possible total of 306 structured parking spaces are proposed in a garage that would be located in the middle portion of the building. If an estimated 19,000 square feet of commercial space is installed and 1 parking space per 250 square feet of commercial space is allocated for the commercial component, 76 of the parking spaces would be used for the office uses. The result is approximately 230 onsite parking spaces for the possible 360 bedrooms. This is a total number of parking spaces equal to 0.64 spaces per bedroom.

The petitioner is also proposing 16 back-in, angled parking spaces on Pete Ellis Drive. There is one vehicular access into the building from Longview Avenue.

There is currently a 5' wide concrete sidewalk along Pete Ellis Drive and 8' wide, multi-use paths along 7th Street and Longview Drive. The petitioner has committed to widening the Pete Ellis Drive sidewalk to a minimum of 6' wide, as well as widening the 7th Street and Longview Drive 8' multi-use paths to 12' wide, concrete multi-use paths. A minimum 5' wide tree plot will also be installed along the 7th Street and Longview street frontages. Along Pete Ellis Dr. the petitioner has proposed to use planter beds and rain gardens, along with varying shrub mixtures instead of a typical tree plot. These will be maintained by the Petitioner.

Bicycle Parking and Alternative Transportation: The development has 360 proposed bedrooms and between 12,000 to 19,000 square feet of commercial/office space. The UDO requires one bicycle parking space for every 6 bedrooms and one bicycle space for each 15 parking spaces for the commercial use. Since the project is larger than 20,000 square feet, all bicycle parking spaces must be covered. They will meet current UDO bicycle parking requirements by providing both bicycle parking spaces along the exterior of the building as well as internal bike storage areas. The eastside local 8 bus, as well as an intermittent 3 line bus both pass the property on the eastern side.

Architecture/Materials: Due to the unique design of the building and different elements that are being included, it is difficult to hold the building to the design standards of one specific district. Instead, the proposed renderings and elevations show the amount of modulation, building design elements, and articulation required. Substantial modulation has been shown around the building and includes recessing portions of the upper floor. Materials to be used include brick and block masonry, metal/steel, storefront glass, stone, and fiber-cement siding.

Environmental Considerations: The petition site is a grassed open space and will be almost entirely developed. The petitioner proposes a 70% impervious surface coverage maximum. The CL zoning district has a 50% maximum coverage requirement. The petitioner proposes to use a series of downspouts and cisterns to capture some of the building stormwater runoff and utilize it to water landscaping and planters, as well as for some of the proposed community garden space.

Housing Diversity: The petitioner has provided 2 options to address the diverse housing that is called for in the Comprehensive Plan. The options presented for diverse housing are still not consistent with other approved projects and the Department does not feel that there has been a clear commitment presented regarding the provision of a diverse housing mix with this petition. This aspect has been something that has consistently been provided with other Planned Unit Developments as a public benefit.

ENVIRONMENTAL COMMISSION RECOMMENDATIONS: The Bloomington Environmental Commission (EC) made 3 recommendations concerning this development, which are listed below:

- 1.) Provide at least 2% of residential parking spaces with electric vehicle charging stations.

STAFF RESPONSE: Although not required, the Department encourages the petitioner to incorporate this suggestion into the design of the parking garage.

- 2.) Prohibit the use of both split-faced and smooth-faced concrete blocks as a façade material.

STAFF RESPONSE: If the Plan Commission approves this project, the Department would support this request to prohibit the use of split-faced and smooth-faced concrete block as an exterior finish.

- 3.) Describe the LEED-compliant practices planned, as well as provide plans for the green or live wall elements being planned along with a maintenance plan for their future viability.

STAFF RESPONSE: If the Plan Commission approves this project, then the Department would recommend this be incorporated into the review of the PUD final plan.

20.04.080(h) Planned Unit Development Considerations

The UDO outlines that in their consideration of a PUD District Ordinance and Preliminary Plan, the Plan Commission and Common Council shall consider as many of the following as may be relevant to the specific proposal. The following list shall not be construed as providing a prioritization of the items on the list. Each item shall be considered individually as it applies to the specific Planning Unit Development proposal.

- (1) The extent to which the proposed Preliminary Plan meets the requirements, standards, and stated purpose of Chapter 20.04: Planned Unit Development Districts.

Section 20.04.010 of the UDO, states that the purpose of the planned unit development (PUD) is to encourage flexibility in the development of land in order to promote its most appropriate use; to improve the design, character and quality of new developments; to encourage a harmonious and appropriate mixture of uses; to facilitate the adequate and economic provision of streets, utilities, and city services; to preserve the natural, environmental and scenic features of the site; to encourage and provide a mechanism for arranging improvements on sites so as to preserve desirable features; and to mitigate the problems which may be presented by specific site conditions. It is anticipated that planned unit developments will offer one or more of the following advantages:

- (a) Implement the guiding principles and land use policies of the Comprehensive Plan; specifically reflect the policies of the Comprehensive Plan specific to the neighborhood in which the planned unit development is to be located;
- (b) Buffer land uses proposed for the PUD so as to minimize any adverse impact which new development may have on surrounding properties; additionally provide buffers and transitions of density within the PUD itself to distinguish between different land use areas;
- (c) Enhance the appearance of neighborhoods by conserving areas of natural beauty, and natural green spaces;
- (d) Counteract urban monotony and congestion on streets;
- (e) Promote architecture that is compatible with the surroundings;
- (f) Promote and protect the environmental integrity of the site and its surroundings and provide suitable design responses to the specific environmental constraints of the site and surrounding area; and

- (g) Provide a public benefit that would not occur without deviation from the standards of the Unified Development Ordinance.
- (2) The extent to which the proposed Preliminary Plan departs from the Unified Development Ordinance provisions otherwise applicable to the subject property, including but not limited to, the density, dimension, bulk, use, required improvements, and construction and design standards and the reasons why such departures are or are not deemed to be in the public interest.

PROPOSED FINDINGS: The proposed deviations from the UDO that are outlined in the PUD District Ordinance are necessary to further the purpose of the PUD which is to provide an innovative building that is appropriately designed for this area. The Petitioner has attempted to address deviations related to increased building height through modulation and recessing sections of the building. These architectural elements also help break up the massing from the building as a result of the increased density and building size. It is completely at the Plan Commission and City Council's discretion if the proposed deviations from the UDO standards are warranted, however the Department is concerned about the proposed height in relation to the surrounding area. Although 50' of height is allowed in the surrounding RH and CA zoning districts, there are no nearby areas with a height greater than three stories. With a proposed height of 52'-61' at the building corners, the proposed building may appear out of character with its surroundings.

- (3) The extent to which the Planned Unit Development meets the purposes of this Unified Development Ordinance, the Comprehensive Plan, and any other adopted planning objectives of the City. Any specific benefits shall be specifically cited.

PROPOSED FINDINGS: While the petition does further some of the goals of the UDO and the Comprehensive Plan, the Department does not believe that the requested PUD provides the amount of public benefit that was encouraged with the Comprehensive Plan and objectives of the City. Although the building provides many features and amenities for the tenants, the amount of overall public benefit has not been sufficiently demonstrated. No firm commitment toward a diverse housing mixture has been brought forward.

- (4) The physical design of the Planned Unit Development and the extent to which it:
- a. Makes adequate provision for public services;
 - b. Provides adequate control over vehicular traffic;
 - c. Provides for and protects designated common open space; and
 - d. Furthers the amenities of light and air, recreation and visual enjoyment.

PROPOSED FINDINGS: The PUD provides adequate public services by improving the adjacent multi-use paths along 7th Street and Longview Drive and new angled, on-street parking along Pete Ellis Drive. Vehicular traffic into the building will only occur at one access point along Longview Drive. Although the petitioner is proposing a reduced level of impervious surface coverage, this reduction is based on a dense, infill site design that would be typical of a Downtown design rather than a suburban location and is based on a desired overall development plan. There are several amenities that are provided for residents and these are outlined in the petitioner statement and submitted site plans. The increased setback to the north property line provides an

increase in separation for light and air between this and the adjacent property.

- (5) The relationship and compatibility of the proposed Preliminary Plan to the adjacent properties and neighborhood, and whether the proposed Preliminary Plan would substantially interfere with the use or diminish the value of adjacent properties and neighborhoods.

PROPOSED FINDINGS: This site is surrounded by high density multifamily residences and commercial uses. While the density proposed on this site is higher than surrounding properties, this type of dense infill development is encouraged when surrounded by appropriate infrastructure and goods and services. The site is adjacent to 3 public roads and is therefore well serviced. In addition, it is located immediately adjacent to several grocery stores and shopping areas, as well as is on a Bloomington Transit bus route.

- (6) The desirability of the proposed Preliminary Plan to the City's physical development, tax base and economic well-being.

PROPOSED FINDINGS: The provision of an estimated 280 units and possible 19,000 square feet of potential medical office space will increase the tax base to the City and provide office space adjacent to the new Hospital location. However, the lack of a diverse housing mixture with this petition does not further the goals of economic well-being in relation to providing a mixture of housing types for the community. The proposed height when compared to the existing surrounding buildings is also a concern.

- (7) The proposal will not cause undue traffic congestion, and can be adequately served by existing or programmed public facilities and services.

PROPOSED FINDINGS: This site will be accessed from 3 different access points which will help distribute the vehicular traffic to this site. Pete Ellis Drive is classified as a Primary Collector and Longview Drive is classified as a proposed Primary Collector, these designations are indicative of highly used roads and therefore appropriate locations for increased density. The Department and the petitioner have committed to re-studying this area to insure that traffic is properly controlled through this corridor and the petitioner will submit a traffic study with the final plan if approved.

- (8) The proposal preserves significant ecological, natural, historical and architectural resources.

PROPOSED FINDINGS: There are no known significant ecological, natural, historical or architectural resources on this site.

- (9) The proposal will not be injurious to the public health, safety, and general welfare.

PROPOSED FINDINGS: The PUD is adequately buffered from adjacent residential properties and the petitioner has shifted the development as far south as possible to reduce impacts to the adjacent residences to the north.

- (10) The proposal is an effective and unified treatment of the development possibilities on the PUD site.

PROPOSED FINDINGS: The establishment of a PUD for this property allows a unique development that would not otherwise be accomplished within an existing zoning district and under the UDO guidelines. While creation of this PUD allows the necessary deviations from the UDO requirements to allow the construction of a unique building, the Department does not feel that the goals of the Comprehensive plan have been effectively incorporated into the petition.

CONCLUSION: While the proposed PUD does offer a unique architectural design and a range of benefits and features for the tenants, the Department does not believe that allowing a development that is twice as dense as the underlying zoning district and an additional 20' in height at this location without providing a strong public benefit, such as diverse housing mix, warrants designation of the area as a Planned Unit Development. The Comprehensive Plan clearly encourages incorporating diverse housing types within the City and a PUD should further this goal and provide a clear public benefit. Some examples of a public benefit include a unique architectural design, a high level of environmental design, and contributing to the diverse housing needs of the community. Further, as mentioned earlier in this report, the Department is concerned that the proposed height is uncharacteristic with the surrounding residential and commercial buildings.

RECOMMENDATION: The Planning and Transportation Department recommends that the Plan Commission adopt the proposed findings and forward this petition to the Common Council with a negative recommendation.



SCHMIDT
ASSOCIATES

February 18, 2019

Terri Porter
Director of Planning and Transportation
The City of Bloomington
401 North Morton Street, Suite 130
Bloomington, IN 47404

Re: Project Review Summary for Curry Urban Properties
Bloomington City Architect – 2017-040.CUP

Dear Terri:

Per your request, Schmidt Associates has reviewed the Plan Commission Resubmittal for Curry Urban Properties on the northwest corner of East Longview Avenue and Pete Ellis Drive. The submittal is dated November 26, 2018. Although this is a resubmittal, per our records, the original submittal of this project was not shared with us for requested feedback.

Staff comments received for the resubmittal of this project are as follows:

- The 3.2-acre site is currently vacant and surrounded by right-of-way on three sides.
- The Petitioner requests a change in zoning from CL to Planned Unit Development (PUD).
- The Petitioner proposes a four-story building with office on the first floor and 3 floors of multi-family above.
- The multi-family units will be a mix of studios, one-beds, and two-beds, with a total of 280 units, 360 beds with 30% of the units expected to be 2-bed units.
- There will be 15,000 to 20,000 square feet of medical office space on the first floor Pete Ellis frontage with apartments behind.

Eric Gruelich requested that our review and comments for this project review focus only on the exterior massing, elevations, and materials. He noted that you would also like our perspective on whether the building scale and appearance could be appropriate and successful if:

- A fifth floor were to be added.
- There was a horizontal break somewhere near the middle of the Longview elevation which would separate the massing into an east block and a west block, with some space between them.

Our observations regarding the project context are as follows:

- The area surrounding the project site is a mix of multi-family residential, small, and big-box businesses and St. Marks United Methodist Church.

415 Massachusetts Avenue
Indianapolis, IN 46204
317.263.6226
317.263.6224 (fax)
www.schmidt-arch.com

Principals

Ron Fisher, AIA, LEED AP
Wayne Schmidt, Hon.D., FAIA
Sarah Hempstead, AIA, LEED AP
Desma Belsaas, AIA, LEED AP
Kevin Shelley, AIA, LEED AP
Brett Quandt, CDA
Lisa Gomperts, FAIA, LEED AP
Anna Marie Burrell, AIA, RID
Tom Neff, AIA, RID, LEED AP
Kyle Miller, PE, LEED AP
Ben Bain, CPSM
Eric Broemel, PE, CEM
Steve Schaecher, AIA, LEED AP

Associates

Steve Alspaugh, AIA, LEED AP
Ryan Benson, AIA
Duane Dart, AIA, CMQ/OE, LEED AP
Craig Flandermeyer, RLA, LEED AP
Jim Heinzelman
Greg Hempstead, AIA, LEED AP
Cindy McLoed, AIA
Megan Scott, CPSM
Charlie Wilson, CPD, LEED AP
Mary Ellen Wolf, AIA, LEED AP
Liming Zhang, RLA, CPESC, LEED AP

Registered Professionals

Brad Brutout, AIA
Asia Coffee, IIDA, RID
Gabe Currier, PE, LEED AP
Matt Durbin, CTS, MCSE
Brandon Fox, AIA
Laura Hardin, IIDA, RID
Allen Jacobsen, PE
Eddie Layton, AIA, LEED AP
Robin Leising, CSI, CCA
Phil Medley, AIA, PE
Tom Ning, RA
Joe Redar, AIA
Jeff Reed, PE
Parveen Tai, MBA, PHR, SHRM-CP
Chuck Thompson, CSI, CCS
James Walde, PE



Letter to Terri Porter
 Visioning Plans
 February 18, 2019
 Page 2

- The structures are a mix of gables and flat roofs with both large and small building footprints.
- The area lies just south of the proposed new hospital location, so it is likely anticipated that it will provide for the large and nearby housing need that will accompany that new medical labor influx.

Our comments regarding the project's design are as follows:

MASSING AND ELEVATIONS

1. The building height is set at four stories. There is a range in heights of 48' to 57' at the center of each facade and 52' to 61' at the building corners, which is significantly higher than the 40' restriction of the current CL zoning. The change to PUD would allow for the negotiation of a potential height increase, but more at issue here may be whether the City is ready to begin moving toward its "build-forward" expectations as communicated on the Comprehensive Plan. If the property is within a designated Regional Activity Center which promotes future development of higher density multi-family housing and encourages vertical growth, this development provides that. Ultimately, the comfort level with the height issue and beginning to realize development of a "build-forward" approach will be determined by the City of Bloomington.
2. The current context of the neighborhood would suggest a maximum of three stories to be more consistent with the scale of the surrounding structures. At four stories, it would easily be the tallest building in the area. For reference, the gable of the worship space of nearby St. Marks United Methodist Church appears to be close to 60'.
3. We would not recommend that a fifth floor be added. The Petitioner Statement (page 4, paragraph 3) even notes that "moving to a 5-story or taller building would not result in a feasible economic model" and "would likely be viewed as imposing if five or more stories."
4. The building massing is well-modulated, both horizontally and vertically, on all four elevations. There is a good amount of dimensional depth in the modules to provide visual interest, shade, and shadow to the facades.
5. Building corners are shown as taller volumes, some with unique applications of wrap-around asymmetrically-framed curtainwall elements, projecting balconies, and enhanced cornice elements.
6. The vertical modulation provides some step-down in height between the third and fourth stories on roughly 20% of each facade to address the height concern to some degree. In addition, the roof line has a good amount of modulation as well.
7. For the most part, the building massing successfully masks the large parking garage at the interior of the development. Its primary exposures are on portions at the center of both the north and south elevations. These elevations present the opportunity to enhance those exposures with additional appropriate facade treatments.



Letter to Terri Porter
 Visioning Plans
 February 18, 2019
 Page 3

8. In addition to residential access from the parking decks, residential access from the street is balanced with access provided on all three street frontages.
9. Commercial space within the development is placed along Pete Ellis Drive and turns the southeast corner along Longview Avenue. This is compatible with existing commercial development primarily on the east side of Pete Ellis Drive which leads to the larger commercial developments to the south.
10. Regarding a potential break in the massing along the south elevation, it is our opinion that it would likely have only a minor impact. Visually, the eye will easily bridge a distance of 20' or less to limit the break's effectiveness without a corresponding change in height. A change in height to three stories for a longer portion of the building would have a greater impact.
11. It appears that the Petitioner has taken positive steps to address the Plan Commission's concerns raised in the November 5, 2018 Plan Commission Hearing, specifically:
 - a. Shifting the building further away from the northern setback to address the concern for casting of shadows on the existing three-story multi-family housing to the north.
 - b. Removal of balconies on the north elevation in response to concerns regarding potential sight lines into units of neighboring development to the north from adjacent balconies.
 - c. Reduction in building mass with the elimination of 12 units, the shift to the south described above, and the lowering of the floor-to-floor heights to lessen the overall heights by 1 to 4 feet in various locations around the building. From our experience, the new floor-to-floor height of 9'-6" is about as tight as can be done to maintain a visually comfortable living space.
 - d. The small improvement in open space is helpful, but not close to the requested 50%. The site design, however, takes a good approach with respect to:
 - 1) Expanded sidewalks and intentional community connectivity through the introduction of outdoor spaces/seating with landscaping in the public realm.
 - 2) Well-designed interior courtyard spaces with generous landscaping.
 - 3) Incorporation of a well-considered system to manage storm water quantity and quality in its two interior courtyards.
 - e. Addressing of potential bicycle traffic, safety, and connectivity issues.
 - f. Reduction of the development D.U.E. by 10%, resulting in a 30 D.U.E.

MATERIALS

1. The primary materials are not clearly shown on the exterior building elevations at this point, but are listed in the Petitioner's Statement as:
 - a. Varying brick and block masonry
 - b. Metal/steel
 - c. Storefront glass and framing for the commercial areas and potentially, portions of the residential building areas



Letter to Terri Porter
Visioning Plans
February 18, 2019
Page 4

- d. Fiber-cement composite (Hardie) siding/board and batten
 - e. Stone
2. The material choices are appropriate for the building type and appear to be well-considered from what we can glean from material representations on the renderings. We would expect the indication of stone is a reference to real stone and preferably limestone for consistency with the material themes of Bloomington.
 3. The building's modulation is further enhanced with surface changes in the material palette.

We would be happy to further discuss ways to improve the design with the architect at the request of the city.

Sincerely,

SCHMIDT ASSOCIATES, INC.
Architecture • Engineering • Interior Design • Landscape Architecture

Sarah Hempstead, AIA, LEED, AP
CEO/ Principal
shempstead@schmidt-arch.com

Steven K. Alspaugh, AIA, LEED AP BD+C
Design Architect/Associates
salspaugh@schmidt-arch.com

SKA:jab



City of Bloomington
Bloomington Environmental Commission

MEMORANDUM

Date: March 18, 2019

To: Bloomington Plan Commission

From: Bloomington Environmental Commission

Subject: PUD-30-18: Curry Urban Properties, second hearing
100 block of Pete Ellis Drive

The purpose of this memo is to convey the environmental concerns and recommendations of the Environmental Commission (EC) with the hope that action will be taken to enhance its environment-enriching attributes. The EC reviewed the petition and offers the following comments and requests for your consideration.

The EC realizes the Petitioner reduced the size of the footprint of the building, which provides for additional landscaping; however, we continue to believe that the plan still does not meet the intent of a Planned Unit Development (PUD). The purpose of a PUD is, in fact, to encourage flexibility in development. However, it appears that the petitioners have simply asked for reduced setbacks, greenspace, and many other divergences from the regulations without providing sufficient public benefit that would not occur without deviation from the standards of the Unified Development Ordinance (UDO). The PUD District Ordinance describes several impressive amenities being considered for the project; however, we have no guarantee that they will ever be established or maintained.

EC CONCERNS OF ENVIRONMENTAL SIGNIFICANCE

1.) FOLLOW UDO ENVIRONMENTAL STANDARDS

The EC believes that any PUD District Ordinance should not reduce the environmental protection requirements to less than the minimum Unified Development Ordinance (UDO) standards. A number of years ago staff and citizens of Bloomington worked tirelessly to craft the development regulations we now find in the Bloomington Municipal Code. These standards went through a public process and were vetted by the citizenry and voted on by our lawmakers. Although it's time to update the regulations, the trend in Bloomington had been to strengthen its environmental standards, not weaken them.

2.) ELECTRIC VEHICLE CHARGING STATIONS

The parking areas for the multifamily units should be equipped with *at least* 2% of the spaces plug-in-ready for electric vehicle charging stations. The Petitioner's Statement didn't call for any particular number of them to be installed.

3.) URBAN FEEL OF THE SITE

If the Petitioner intends to create a development that emulates an urban development (i.e. high density and height, etc.), then they should adhere to all urban qualities. The EC recommends that building materials such as split-faced or smooth-faced concrete blocks be prohibited, and local limestone be used as accents to recreate Bloomington's sense of place.

4.) GREEN BUILDING PRACTICES

Describe the LEED compliant features that are mentioned on page 8 of the Petitioners' Statement, and also provide the design and maintenance plans for the green or live wall elements incorporated into building/garage screening.

EC RECOMMENDATIONS:

- 1.) Provide at least 2% of residential parking spaces with electric vehicle charging stations.
- 2.) Prohibit the use of both split-faced and smooth-faced concrete blocks as a façade material.
- 3.) Describe the LEED-compliant practices planned, as well as provide plans for the green or live wall elements being planned along with a maintenance plan for their future viability.

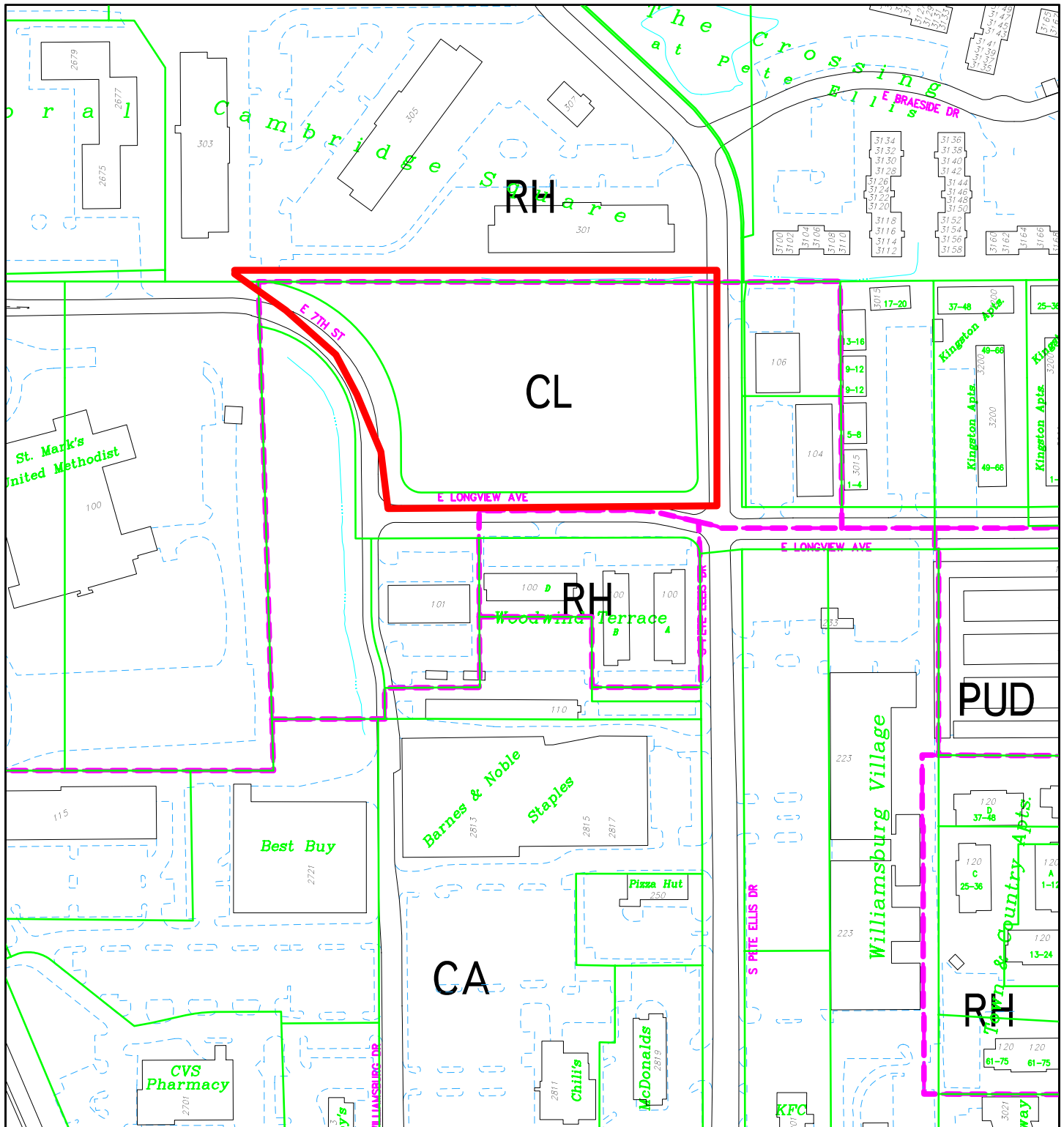

By: scanlanj
21 Sep 18

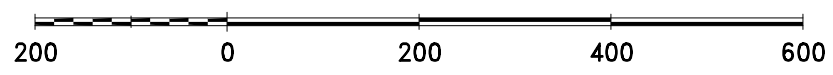

City of Bloomington
Planning & Transportation

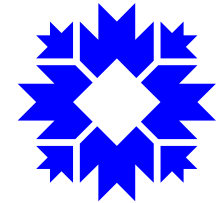

Scale: 1" = 200'

For reference only; map information NOT warranted.

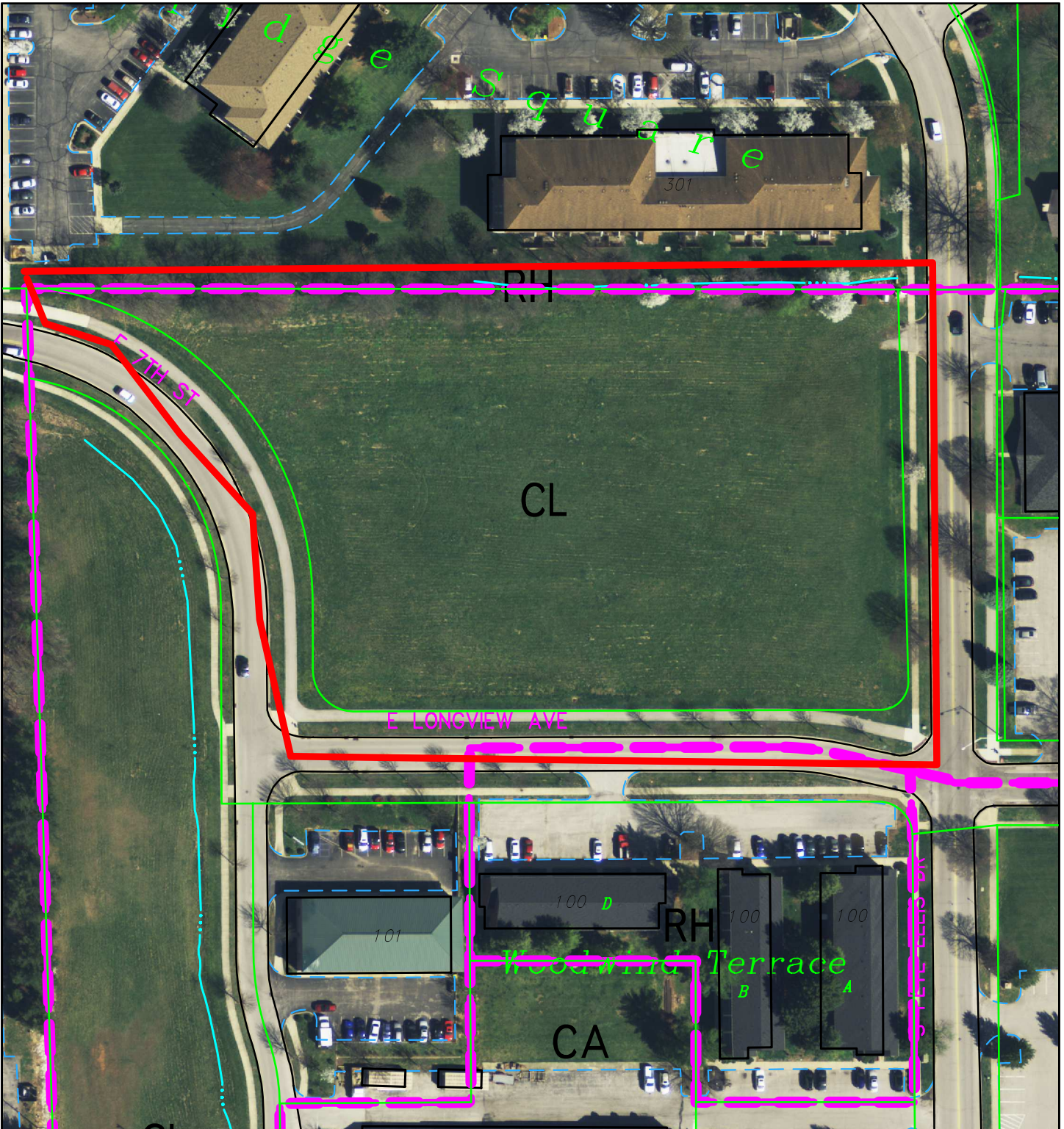

By: scanlanj
21 Sep 18

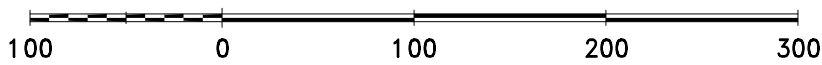

For reference only; map information NOT warranted.



City of Bloomington
Planning & Transportation

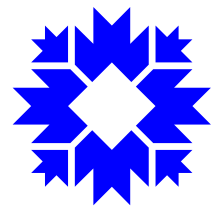

Scale: 1" = 100'

PETITIONER'S STATEMENT – REVISED 3.1.19

Petition:

Rezone real estate identified as Lot Number 8, located in Deckard East Third Street Subdivision, Monroe County, Indiana consisting of 3.2 acres from CL to Planned Unit Development (PUD).

Project Description:

Petitioner petitions for rezoning of the property from Commercial Limited to a mixed use, Planned Unit Development. The property currently is unimproved. Various utility lines border and bisect the property. The property is surrounded to the North by multi-family housing under RH zone. East of the property fronting on North Pete Ellis Drive are commercial properties, developed commercial lots under CL zoning. East of the lots fronting on North Pete Ellis Drive are additional multi-family housing under RH zoning. Southeast of the property is zoned CA. South of the property and fronting on Longview Avenue are multi-family housing under RH zoning. At the southwest corner of the property south of Longview Avenue is a small commercial development under CL zoning. West of the property fronting on East Seventh Street is a vacant, unimproved parcel.

Petitioner proposes to develop a mixed-use development consisting of multi-family residential use on a building outlining the west one-half of the property; 1st floor commercial use on the building outlining the east ½ of the property and a 3-floor interior parking garage in the middle of the property with top floor (4th floor) residential units. The buildings will be connected and constructed as a single building but with breaks and variations by design, by structural elements (e.g., the garage) and by façade features. The proposed building is projected at four floors. The center of the property on the east and west sides of the garage will be developed with courtyard/pervious surface.

RESUBMITTAL MODIFICATIONS

Since the initial Planning Commission hearing on November 5, 2018, the Petitioner has had follow up meetings with members of Bloomington Economic and Sustainable Development, Housing and Neighborhood Development, Planning and Transportation, and the Environmental Commission and has worked to address comments and concerns stemming from the initial submission and those expressed by the Planning Commission during the hearing. The comments/concerns and responses from the Petitioner are outlined below:

- Neighboring apartment community to the north (zoned RH) expressed concern about the possibility of shadows being cast upon their property due to the massing and proximity of the petitioner's proposed development. Concerns of sight lines into units from adjacent balconies was also raised (Cate)

Petitioner Response: Although the Petitioner could build a 40' tall building "by right" at a 10-foot setback from the northern boundary of the property (the boundary adjacent to the concerned neighbor), Petitioner has agreed to shift the entire building in-ward from the northern set-back, thus modifying the previously proposed set back of 7 feet to 15 feet (with exception of the north east corner unit which is 14 feet from the property line). Moreover, numerous modulations of the building at the 4th floor will step back another 5 feet (or 20 feet from the property boundary) to provide relief of the building height and mass. Additionally, Petitioner voluntarily eliminated numerous balconies along the north elevation in addition to proposing the planting of additional, large canopy trees, to accompany the existing trees and in order to respect the neighbor's concerns.

Petitioner spoke with representatives of the property owner, including their Asset Manager and Corporate General Counsel (CGC) to clarify design, density, height, setback and other elements of Petitioner's proposed development. At the close of this communication, neighboring owner's CGC stated that unless Petitioner heard from him otherwise that they were satisfied with Petitioner's response. Petitioner has received no further communication from CGC or neighboring owner,

- Overall Building Massing seen as a concern (EC, Scanlan, Kinzie)

Petitioner Response: Petitioner recognizes that the project is a single building (actually 3 buildings connected) rather than separate structures, and whose massing is more consistent with that of urban developments. The Petitioner is intending to provide the feeling of a more "urban" context to the structure in a secured, contiguous, building with conditioned interior corridors. Moreover, the building and exterior/perimeter improvements provide a "build-forward" design concept, consistent with the Comprehensive Plan. It should be reiterated that the subject property is within a designated Regional Activity Center and part of the Regional Academic Health Center Focus Area whose intent is to promote higher intensity uses; medium- to high-density multifamily uses; to provide semi-urban activity centers that complement downtown; encourage vertical growth, residential multi-family, denser office uses, structured parking and improved multi-modal connectivity.

However, the Petitioner has reduced the building mass by shrinking the building and eliminating 12 units (and 12 beds). As noted, the northern set back was moved inward from the initial petition, basically doubling the set back. This also helps to increase pervious surface on the property. In numerous places along each elevation of the building, the 4th floor units are stepped back 5 feet. This is done to provide some relief from the proposed, four-story height. Finally, the Petitioner has worked with its architect to further reduce several parapet heights to lower the overall height in numerous areas. Although the building height remains 61 feet at its tallest feature at the SW corner (measured from adjacent grade to roof parapet), roof lines have been reduced from 1 to 4 feet in height in various places around the building. While the building height exceeds the 40-foot restriction of CL zoning, it does retain a varied, articulated roofline for functional and aesthetic reasons.

- Environmental concerns as to the project being below the pervious surface requirement; impervious surfaces (EC, Sandberg, Cate, Kinzie, Kappas). EC has requested the Petitioner redesign the building.

Petitioner Response: Although Petitioner will not redesign the building, Petitioner has worked with the architects and engineers to reduce the building size, shrinking the building mass and creating pervious surface vis-à-vis compressing the building inward, from north to south (more than doubling the northern set back) and from east to west to add four feet of additional set back from the eastern side. The resulting changes have resulted in nearly a 25% improvement to pervious surface compared to the Petitioner's initial submittal. Although Petitioner will not be able to reach the 50% pervious surface request, it has improved the pervious surface from 25% to 31% and will be significantly exceeding the landscaping and planting requirements as well as the water quality requirements.

Petitioner has further reduced the paved surfaces and covered area and/or has worked with the landscape architect to program permeable materials for pathways. It should be noted that the eastern property boundary includes a 20-foot easement for utilities. Coupled with the utilities that run throughout the 15-foot Right-of-Way along Pete Ellis Drive, the Engineer and Landscape architect have not programmed trees (large, evergreen or medium) along the frontage as trees cannot be planted within 10 feet of the easement. Petitioner will work through its landscape architect (Rundell Ernstberger Associates) and the city of Bloomington to address this along with the overall landscape plans.

Petitioner will be expanding pedestrian sidewalks and paths that surround the property along 7th Street, Longview Avenue and Pete Ellis Drive under the direction of Bloomington Transportation. Additionally, Petitioner will work with the city to install back-in angled parking (as requested by Planning Commission) along the western lane of Pete Ellis Drive, which would expand the existing Right-of-Way onto Petitioner's property, and into the easement. The street frontage will be landscaped and hardscaped with a 6-foot sidewalk bordered on each side by storm planters within the sidewalk, and flow-through planters against the building which serve to collect rain water from roofs of the proposed structure. This rain water will be harvested within cisterns and be used for irrigation purposes, while overflow will be directed into flow through planters and storm planters. A stormwater planter / rain garden will be included within the Right-of-Way to control storm water along the street and parking area. Permeable pavers will be utilized in several portions of the project, especially along the Pete Ellis Drive promenade.

While Petitioner had already planned community gardens and many of the water quality improvements, among other public benefits, it has sophisticated a concept landscape plan with its landscape architect that includes managing rain water and storm water quality via rain gardens, and rain water diversion and harvesting through cisterns, flow thorough planters and rain gardens within each of the interior courtyards. However, the most compelling response Petitioner can provide is that the planting and landscape requirements established by the city will be significantly exceeded by Petitioner (see Concept Plant Schedule).

- Bicycle Traffic, Safety and Connectivity / Traffic along Pete Ellis Drive. Several members of the Planning Commission responded to the parking along Pete Ellis as well as wanting to make certain the bicycle and pedestrian paths remain safe amid the ingress/egress to the proposed building (Kopper, Kinzie, Wisler, Hoffman)

Petitioner Response: From the onset, Petitioner has worked to promote a bicycle-friendly community, where this development provides connectivity. The multi-modal functionality of the location and design of the project is not by accident. Petitioner, through its third-party professionals, has worked with Bloomington Transportation to address these concerns. The result is the back-in angled parking, expanded bicycle paths and expanded bicycle parking to be located near the entrance of the garage and proximate to the proposed, expanded B-line along Longview Avenue. Further, Petitioner will analyze best solutions and install safety/warning controls at parking garage ingress/egress. Finally, should the project be approved by City Council, Petitioner will commission a traffic study for Pete Ellis Drive and the angled parking, as well as the surrounding traffic patterns.

- Density- although not called out specifically as an issue the comments as to massing are consistent with density in this regard. In fact, many members of the Planning Commission expressed that they welcome increased density or are in favor of increased density rather than sprawl.

Petitioner Response: Petitioner has revised the density to be no more than 30 D.U.E per acre versus the prior 33 D.U.E, a 10% reduction. The resulting 30 D.U.E is compatible with the apparent as built density of nearly all other multi-family properties in the surrounding area (zoned RH). To simply achieve the density of what competing properties already have pursuant their zoning classification, moving to a 5-story or taller building alone would not result in a feasible economic model. Building to this level would change the construction class/type, a much more expensive proposition. Thus, achieving even 30 D.U.E, and parking it adequately would be very difficult without at least a 4-story structure covering 60% or more of the site. Subterranean parking would also be cost prohibitive. Separate structures as well as a podium structure along with stand-alone office building was studied but would not achieve an economic model that was feasible, nor would it significantly improve the pervious surface. Moreover, higher structures in this location would likely be viewed as imposing if five or more stories, considering the concern over the proposed 4-story structure.

DEVELOPMENT STANDARDS SUMMARY / OUTLINE PLAN DETAILS:

Commercial space:

Estimated at 20,000 square feet; no less than 12,000 square feet would be programmed for the development.

Multi-family residential:

Studios, 1-bedroom and 2-bedroom mix. D.U.E not to exceed 30 per acre

Parking:

306 garage spaces; 16 potential on-street parking spaces (angled parking along Pete Ellis
76 garage spaces to serve commercial use

Residential parking: 230 garage spaces (.86/unit; .66/bed). Development not to
exceed .90/unit and .70/bed

Architectural Standards: Due to the unique design of the building and different elements that
are being included, it is difficult to hold the building to the design standards of one specific
district. Instead, the proposed renderings and elevations show the amount of modulation,
building design elements, and articulation required.

Exterior materials: varying brick and block masonry; metal/steel; storefront glass and
framing (commercial and potentially portions of residential building areas); fiber-cement
composite (Hardie) siding/board and batten; stone

Site plan details:

Setbacks: varying by side and building façade (see site plan diagram)

North side: 14 feet at NE Corner, 15 feet or more elsewhere (modified from 7')

East side: 24 feet (modified from 20')

South side: 4.5 feet (southwest corner) to 9 feet

West side: 4.5 feet at point of 7th street curve; varying distance 7 feet minimum
for remainder

Garage entrance: Longview Ave.

Uses: CL zone permitted uses

Modification: add first floor multifamily residential use

No Maximum floor space for a single tenant

Basic PUD development:

1. Dedicated commercial space, expected to be 19,000 square feet on the east side, fronting
on S. Pete Ellis Drive. This space will be flexible in total area.

This space is anticipated to be medical office space and will be marketed as such.

2. Multi-Family residential use (mix of studio, one-bedroom and two-bedroom apartments);
generally, the units are oriented to those seeking a more personal, single-living
environment.

Targeted market: staff and employees associated with the IU Health complex; single professionals and staff and employees associated with the offices and accessory businesses expected to develop adjacent to the IU Health complex

3. Building height to be 4 floors. Throughout the building, numerous portions of the building's 4th floor are set back from the lower floors. Along the eastern portion of the building, the length of the building along Pete Ellis Drive steps back 5 feet at the 2nd floor and another 5 feet at numerous areas along the 4th floor.
4. Residential buildings will allow first floor residential use (CL Zone requires 2nd floor and above residential use) with commercial along Pete Ellis Drive.
5. Pervious surface (to be calculated) estimated at 31% of the lot. This pervious surface is below the current CL zoning standards, the site shape, topography, the city's build-forward design preference and the economic feasibility of the project necessitate this pervious surface design; however, Developer is proposing to: a.) exceed landscaping and plantings requirements, b.) include plantings vertically with green elements in the garage screening, c.) exceed rain water quality issues with multi-function water harvesting, flow through planters and rain gardens, d.) include numerous sustainable practices including community gardens, and e.) bring numerous public benefit to the project including re-locating and improving current sidewalk paths, as necessary, at Pete Ellis, Longview and 7th street (all three sides) with multi-use paths.
6. Parking – The building will include a four-story structure that is central to the building design. This portion of the building will also serve the project with mixed uses, housing three stories of parking garage with a 4th floor residential component. The Developer has not yet determined the economic feasibility of adding the 4th floor above the 3 floors of parking; therefore, this section of the building may be limited to just three floors of parking structure. Parking garage will be interior to the development with the commercial and residential use building(s) wrapping around the courtyard with parking lot/parking garage interior to the courtyard. Parking garage to extend to the development line along the north property line.
7. Exterior finish materials: multiple types of masonry; steel; glass and composite

Development Standards:

Development standards applicable to the CL Zone will be used for roofs, exterior materials, modulations, and entrances. Development plan will specify building setbacks at each property line frontage.

Building Height:

The building will not exceed four stories. Building height, as measured from proposed finished grade, varies along the length of each side:

North side: ranges from 48 to 53' in center of building to 52' (NE corner) and 53' (NW corner)

East side: ranges from 49' to 54' in center of building to 53' 2" (SE corner) and 52' (NE corner)
 South side: ranges from 51' to 57' in center of building to 53' 2" (SE corner) and 61' (SW corner)
 West side: ranges from 49' to 54' in center of building to 53' (NW corner) and 61' (SW corner)

- a. Architectural roof top or roof line elements to provide both form and function at no more than one point at the peak of any section of building that exceeds 60 feet in height (as measured from adjacent, proposed finished grade at that point of the building).
- b. The site has significant topography slope, particularly along the western border of the parcel. Approximately 20 feet of grade change occurs from the point of the parcel that is furthest to the northwest as compared to the point furthest to the southwest of the parcel. It is anticipated that the building plane at the first-floor level will be set at an elevation which causes the southwest corner of the building (at 7th Street and Longview) to be elevated + 8 feet above the parcel's grade at this location. Thus, the developer is now planning functional space within this "sub-level" of the building that will include 5 or 6 "garden" units which address the Longview street frontage. The space could also serve as storage or other program space for the building. If this sub-level is completed, it would add a "story" to the building at the southwest elevation of the development, albeit below the average grade along 7th Street.
- c. Petitioner has worked extensively with Architect and Civil Engineer to reduce heights around building, and modulate the fourth floor with 5-foot step backs in numerous portions of the building while maintaining dynamic roof lines around the building.

Unit Mix and DUE:

1. The building will include a mix of Studio, One- and Two-Bedroom Units. Projected D.U.E is 29 per acre. Actual development not to exceed 30 per acre. The site is 3.2 acres.
2. The project will house 268 units. As roughly 30% of those units are expected to be Two-bedroom units, the total bedroom count would calculate to 348 bedrooms, although the project is not a student housing community.

Parking:

1. Up to 16 angled parking spaces will be improved along the western-most lane of Pete Ellis Drive, to serve the commercial spaces at that location.
2. The internal parking garage is expected to have no more than 102 spaces per floor and no more than a total of 306 spaces.
3. A portion of the first floor of the parking garage will serve the commercial spaces (Pete Ellis Drive portion of the building) and meet municipal parking code and count requirements as well as the number of spaces required by the ultimate user/tenant.

4. Assuming 4 spaces per 1,000 square feet (assumed user requirement), and a 19,000 square foot user, the commercial spaces will require 76 of the total 322 spaces (16 angled, street spaces and 306 garage spaces). This would leave 246 spaces for 268 units (or 348 beds). Excluding the street parking, this parking ratio is 230 spaces in the garage for residents or 0.86:1 per unit or 0.66:1 per bedroom.

Bicycle parking:

Bike racks and bike storage will exceed requirements for CL and RH zones. Covered, secure bicycle parking and storage will be housed within the garage of the building. The petitioner is proposing additional public bicycle racks at various areas surrounding the building (along the multi-use paths) and will work with Bloomington's share bicycle program to install a kiosk along the perimeter of the property.

Housing:

Oriented to single-living environment around the IU Health Medical Center, University, Service Industry, Young professional, medical/grad students, nursing students, researchers, interns, staff and employees of professional offices and staff and employees at the IU Health complex.

Green Building Elements Planned:

- Energy Star appliances / Energy efficient building materials / LEED compliant
- Downspout Cisterns for on-site rain water harvesting to be used for watering landscaping and other exterior uses
- Downspout flow through planters and rain gardens along perimeter and interior courtyards
- green or live wall elements incorporated into building / garage screening
- Comprehensively, the property will exceed landscape and planting requirements per the current zoning
- Storm water control and quality - series of cisterns, flow-through planters and storm planters (in sidewalk) and rain gardens are proposed along Pete Ellis drive
- Electric car charging stations within parking garage
- Sustainability – community vegetable and herb gardens
- Multi-modal transportation

Public Benefits:

- Workforce housing components – developer has proposed workforce housing commitments in a separate letter to HAND, attached and included with this resubmittal.
- Multi-modal transportation – proposed project is pedestrian to Bloomington's largest work centers (IU Health upon completion, College Mall, Indiana University)
 - Several bus-line stops in proximity to the subject location

- Developer promoting the use of bicycles and non-vehicular transportation through widening of paths around perimeter to multi-use paths, placement of bicycle parking, and public bicycle racks
- Public Art - exterior murals / interior art displayed for public viewing (not just residents); viewings to be programmed
 - Developer proposes to commit to a 5-year program to rotate art periodically (6-month to 1-year rotation) for public display. Works to be commissioned with City of Bloomington.
 - Developer proposes to conduct receptions and “gallery” style viewings, free to public (donations will be accepted for local not-for profit, art related groups)
- Scholarship - public art to be commissioned with IU art department and will be offered to city art programs - works to be displayed within building (can be sold by artists) in return for annual scholarships or grants from developer
- Sustainability: Approximately 1/3 of the interior courtyard space within the western courtyard will be improved with herb, flower and vegetable gardens - improvements will include gardening areas/plots for residents
 - Developer proposes to program monthly events or demonstrations using the planted foods and flowers; such as making floral arrangements; cooking with the harvested vegetables and herbs with local chefs, etc.
 - Gardens will be irrigated with harvested rain water from the cistern system developer is proposing
- “Jam Session” Room - public music room/studio will be included for use by area musicians, music scholars, etc. for "plug-in and play" sessions to create, share and explore musical interests of those within the community looking to "pick up" instruments and create with others
- Amphitheater – directly adjacent to the Jam Session, an amphitheater is planned for live music or other performances, free to the public
- Bike Depot – Developer will work with City of Bloomington to include a public bike depot at the property
- Streetscaping – Developer is re-locating and improving the current sidewalk along Pete Ellis. Proposed improvements along Pete Ellis Drive will include a multi-use path, green and hard scaping, cisterns for water harvesting, rain water flow-thru planters, storm planters, and rain gardens among other elements
 - Public benches will be included
 - Vegetative, floral and landscaping improvements would exceed minimum requirements
 - It is anticipated that large tree planting will not be possible along Pete Ellis Drive proposed improvements due to numerous utility lines and easement which traverses the eastern property border
 - Back-in, angled parking along Pete Ellis Drive is proposed
 - Public bicycle racks/parking will be included in the improved areas
 - Rain gardens (to be built on city ROW) along Pete Ellis are proposed

- Permeable pavers will be incorporated into the hardscape finishes
- Developer is proposing multi-function rain water quality controls in series of steps commencing with harvesting, to overflow within flow-through planters and storm planters, then into rain gardens before flowing to city storm
- Connectivity and Safety - Developer has been asked by City of Bloomington to widen current bicycle paths along Longview and 7th Street, and improve them as 8' to 12' multi-use paths
 - Developer would be accommodating this requested safety and functionality improvement

413420



⊕
 AERIAL SITE PLAN
 NOT TO SCALE

2018.11.26

CURRY URBAN PROPERTIES

EAST LONGVIEW AVENUE
 BLOOMINGTON, INDIANA 47408

TEPO
 DEVELOPMENT + LIFESTYLE

Smith Brebb & Associates, Inc.
 453 S. Clarice Boulevard
 Bloomington, Indiana, 47401
 Telephone: (317) 338-6536
 Web: www.smithbrebb.com
 Follow us on Facebook!

**RUNDELL
 ERNSTBERGER
 ASSOCIATES**
 LANDSCAPE ARCHITECTURE • PLANNING • URBAN DESIGN • CIVIL ENGINEERING
 INTERIORS • LIGHTING • www.runde.com

**LUPTON
 RAUSCH**
 ARCHITECTURE 4
 INTERIOR DESIGN



PETE ELLIS DRIVE
RENDERING

2018.11.26

CURRY URBAN PROPERTIES

EAST LONGVIEW AVENUE
BLOOMINGTON, INDIANA 47408

TEMPO
DEVELOPMENT + LIFESTYLE

Smith Brehob & Associates, Inc.
453 S. Clarice Boulevard
Bloomington, Indiana, 47401
Telephone: (317) 336-6536
Web: www.smithbrehob.com
Follow us on Facebook!



**RUNDELL
ERNSTBERGER
ASSOCIATES**
LANDSCAPE ARCHITECTURE • PLANNING • URBAN DESIGN • CIVIL ENGINEERING
INTERIORS • LIGHTING | www.rundell.com



**LUPTON
RAUSCH**
ARCHITECTURE +
INTERIOR DESIGN





SEVENTH STREET
RENDERING

2018.11.26

CURRY URBAN PROPERTIES

EAST LONGVIEW AVENUE
BLOOMINGTON, INDIANA 47408

TEMPO
DEVELOPMENT + LIFESTYLE

Smith Brehob & Associates, Inc.
453 S. Clarice Boulevard
Bloomington, Indiana 47401
Telephone: (317) 338-6536
Web: www.smithbrehob.com
Follow us on Facebook!

**RUNDELL
ERNSTBERGER
ASSOCIATES**
LANDSCAPE ARCHITECTURE • PLANNING • URBAN DESIGN • CIVIL ENGINEERING
INTERIORS • LIGHTING • www.runde.com

**LUPTON
RAUSCH**
ARCHITECTURE +
INTERIOR DESIGN



CURRY URBAN PROPERTIES

EAST LONGVIEW AVENUE
 BLOOMINGTON, INDIANA 47408



PRECEDENT IMAGERY

CURRY URBAN PROPERTIES

EAST LONGVIEW AVENUE
BLOOMINGTON, INDIANA 47408

TE M P O
DEVELOPMENT + LIFESTYLE

Smith Brehob & Associates, Inc.
453 S. Clarice Boulevard
Bloomington, Indiana 47401
Telephone: (317) 336-6536
Web: www.smithbrehob.com
Follow us on Facebook!

RUNDELL ERNSTBERGER ASSOCIATES
LANDSCAPE ARCHITECTURE • PLANNING • DESIGN SERVICES • CIVIL ENGINEERING
INTERNATIONAL | LOUISVILLE | www.runda.com

LUPTON RAUSCH
ARCHITECTURE + INTERIOR DESIGN

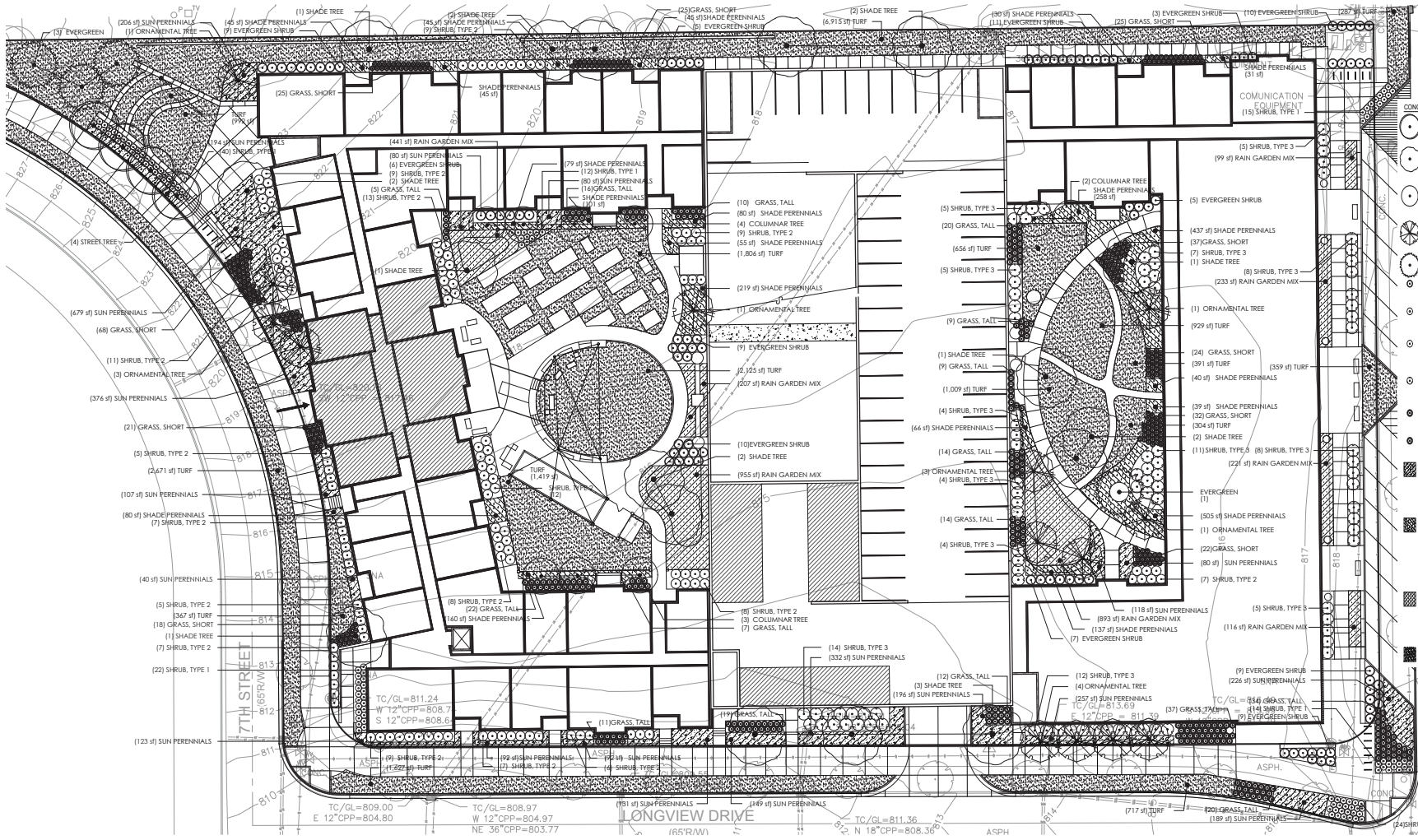

CONCEPT PLANT SCHEDULE

PLANT	QUANTITY	PLANT	QUANTITY
SHRUB, TYPE 1	13	SHRUB, TYPE 3	10
SHRUB, TYPE 2	10	SHRUB, TYPE 5	8
SHRUB, TYPE 3	10	SHRUB, TYPE 6	1
SHRUB, TYPE 4	1	SHRUB, TYPE 7	1
SHRUB, TYPE 5	8	SHRUB, TYPE 8	1
SHRUB, TYPE 6	1	SHRUB, TYPE 9	1
SHRUB, TYPE 7	1	SHRUB, TYPE 10	1
SHRUB, TYPE 8	1	SHRUB, TYPE 11	1
SHRUB, TYPE 9	1	SHRUB, TYPE 12	1
SHRUB, TYPE 10	1	SHRUB, TYPE 13	1
SHRUB, TYPE 11	1	SHRUB, TYPE 14	1
SHRUB, TYPE 12	1	SHRUB, TYPE 15	1
SHRUB, TYPE 13	1	SHRUB, TYPE 16	1
SHRUB, TYPE 14	1	SHRUB, TYPE 17	1
SHRUB, TYPE 15	1	SHRUB, TYPE 18	1
SHRUB, TYPE 16	1	SHRUB, TYPE 19	1
SHRUB, TYPE 17	1	SHRUB, TYPE 20	1
SHRUB, TYPE 18	1	SHRUB, TYPE 21	1
SHRUB, TYPE 19	1	SHRUB, TYPE 22	1
SHRUB, TYPE 20	1	SHRUB, TYPE 23	1
SHRUB, TYPE 21	1	SHRUB, TYPE 24	1
SHRUB, TYPE 22	1	SHRUB, TYPE 25	1
SHRUB, TYPE 23	1	SHRUB, TYPE 26	1
SHRUB, TYPE 24	1	SHRUB, TYPE 27	1
SHRUB, TYPE 25	1	SHRUB, TYPE 28	1
SHRUB, TYPE 26	1	SHRUB, TYPE 29	1
SHRUB, TYPE 27	1	SHRUB, TYPE 30	1
SHRUB, TYPE 28	1	SHRUB, TYPE 31	1
SHRUB, TYPE 29	1	SHRUB, TYPE 32	1
SHRUB, TYPE 30	1	SHRUB, TYPE 33	1
SHRUB, TYPE 31	1	SHRUB, TYPE 34	1
SHRUB, TYPE 32	1	SHRUB, TYPE 35	1
SHRUB, TYPE 33	1	SHRUB, TYPE 36	1
SHRUB, TYPE 34	1	SHRUB, TYPE 37	1
SHRUB, TYPE 35	1	SHRUB, TYPE 38	1
SHRUB, TYPE 36	1	SHRUB, TYPE 39	1
SHRUB, TYPE 37	1	SHRUB, TYPE 40	1
SHRUB, TYPE 38	1	SHRUB, TYPE 41	1
SHRUB, TYPE 39	1	SHRUB, TYPE 42	1
SHRUB, TYPE 40	1	SHRUB, TYPE 43	1
SHRUB, TYPE 41	1	SHRUB, TYPE 44	1
SHRUB, TYPE 42	1	SHRUB, TYPE 45	1
SHRUB, TYPE 43	1	SHRUB, TYPE 46	1
SHRUB, TYPE 44	1	SHRUB, TYPE 47	1
SHRUB, TYPE 45	1	SHRUB, TYPE 48	1
SHRUB, TYPE 46	1	SHRUB, TYPE 49	1
SHRUB, TYPE 47	1	SHRUB, TYPE 50	1
SHRUB, TYPE 48	1	SHRUB, TYPE 51	1
SHRUB, TYPE 49	1	SHRUB, TYPE 52	1
SHRUB, TYPE 50	1	SHRUB, TYPE 53	1
SHRUB, TYPE 51	1	SHRUB, TYPE 54	1
SHRUB, TYPE 52	1	SHRUB, TYPE 55	1
SHRUB, TYPE 53	1	SHRUB, TYPE 56	1
SHRUB, TYPE 54	1	SHRUB, TYPE 57	1
SHRUB, TYPE 55	1	SHRUB, TYPE 58	1
SHRUB, TYPE 56	1	SHRUB, TYPE 59	1
SHRUB, TYPE 57	1	SHRUB, TYPE 60	1
SHRUB, TYPE 58	1	SHRUB, TYPE 61	1
SHRUB, TYPE 59	1	SHRUB, TYPE 62	1
SHRUB, TYPE 60	1	SHRUB, TYPE 63	1
SHRUB, TYPE 61	1	SHRUB, TYPE 64	1
SHRUB, TYPE 62	1	SHRUB, TYPE 65	1
SHRUB, TYPE 63	1	SHRUB, TYPE 66	1
SHRUB, TYPE 64	1	SHRUB, TYPE 67	1
SHRUB, TYPE 65	1	SHRUB, TYPE 68	1
SHRUB, TYPE 66	1	SHRUB, TYPE 69	1
SHRUB, TYPE 67	1	SHRUB, TYPE 70	1
SHRUB, TYPE 68	1	SHRUB, TYPE 71	1
SHRUB, TYPE 69	1	SHRUB, TYPE 72	1
SHRUB, TYPE 70	1	SHRUB, TYPE 73	1
SHRUB, TYPE 71	1	SHRUB, TYPE 74	1
SHRUB, TYPE 72	1	SHRUB, TYPE 75	1
SHRUB, TYPE 73	1	SHRUB, TYPE 76	1
SHRUB, TYPE 74	1	SHRUB, TYPE 77	1
SHRUB, TYPE 75	1	SHRUB, TYPE 78	1
SHRUB, TYPE 76	1	SHRUB, TYPE 79	1
SHRUB, TYPE 77	1	SHRUB, TYPE 80	1
SHRUB, TYPE 78	1	SHRUB, TYPE 81	1
SHRUB, TYPE 79	1	SHRUB, TYPE 82	1
SHRUB, TYPE 80	1	SHRUB, TYPE 83	1
SHRUB, TYPE 81	1	SHRUB, TYPE 84	1
SHRUB, TYPE 82	1	SHRUB, TYPE 85	1
SHRUB, TYPE 83	1	SHRUB, TYPE 86	1
SHRUB, TYPE 84	1	SHRUB, TYPE 87	1
SHRUB, TYPE 85	1	SHRUB, TYPE 88	1
SHRUB, TYPE 86	1	SHRUB, TYPE 89	1
SHRUB, TYPE 87	1	SHRUB, TYPE 90	1
SHRUB, TYPE 88	1	SHRUB, TYPE 91	1
SHRUB, TYPE 89	1	SHRUB, TYPE 92	1
SHRUB, TYPE 90	1	SHRUB, TYPE 93	1
SHRUB, TYPE 91	1	SHRUB, TYPE 94	1
SHRUB, TYPE 92	1	SHRUB, TYPE 95	1
SHRUB, TYPE 93	1	SHRUB, TYPE 96	1
SHRUB, TYPE 94	1	SHRUB, TYPE 97	1
SHRUB, TYPE 95	1	SHRUB, TYPE 98	1
SHRUB, TYPE 96	1	SHRUB, TYPE 99	1
SHRUB, TYPE 97	1	SHRUB, TYPE 100	1

LANDSCAPE PLAN

CURRY URBAN PROPERTIES

EAST LONGVIEW AVENUE
BLOOMINGTON, INDIANA 47408

TEMPOR
DEVELOPMENT + LIFESTYLE

Smith Brebb & Associates, Inc.
455 S. Clavette Boulevard
Bloomington, Indiana 47401
Telephone: (317) 338-6336
Web: www.smithbrebb.com
Follow us on Facebook!

RUNDELL ERNSTBERGER ASSOCIATES
ARCHITECTURE + INTERIOR DESIGN

LUPTON RAUSCH
ARCHITECTURE + INTERIOR DESIGN

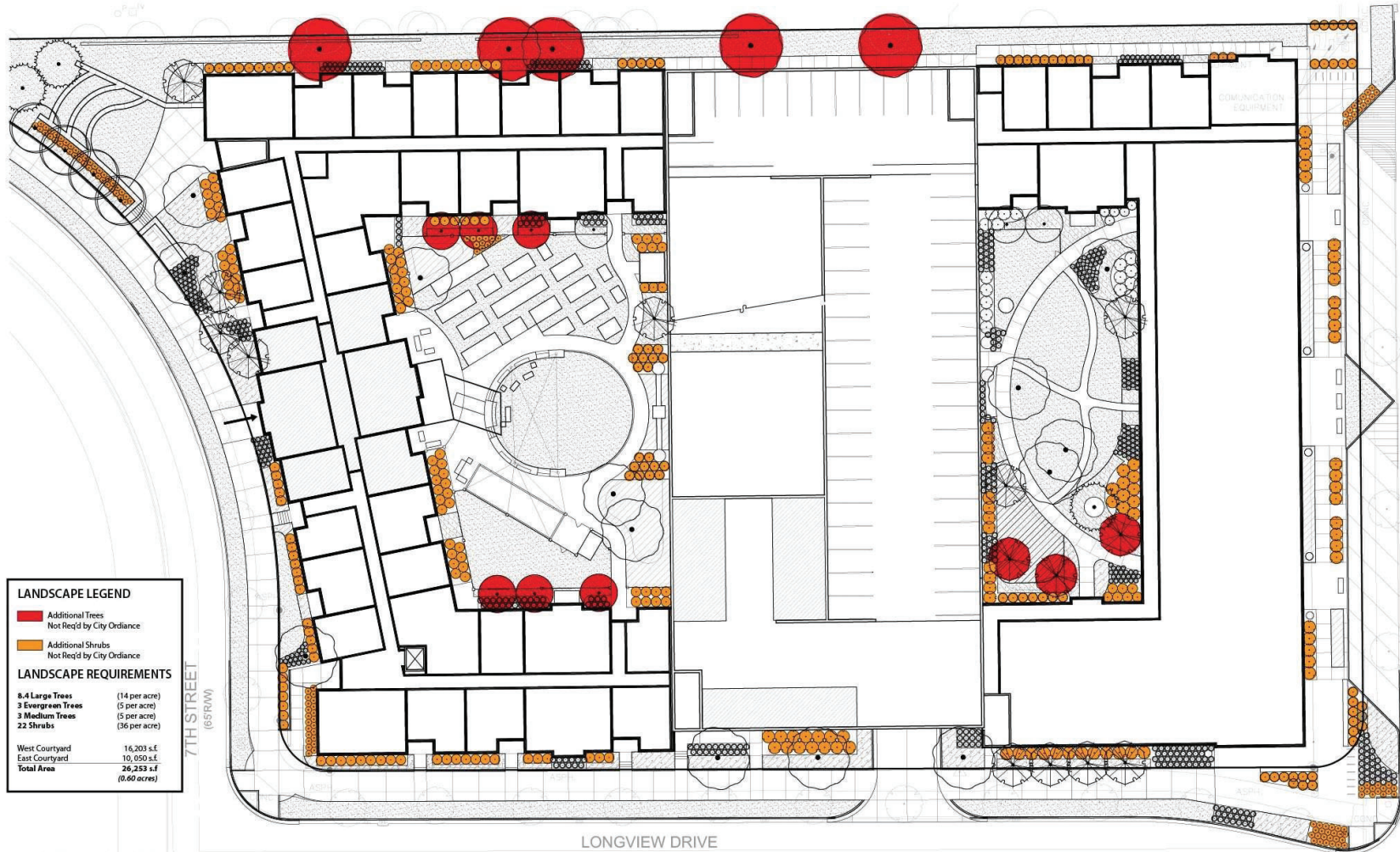

LANDSCAPE LEGEND

- Additional Trees
Not Req'd by City Ordinance
- Additional Shrubs
Not Req'd by City Ordinance

LANDSCAPE REQUIREMENTS

8.4 Large Trees	(14 per acre)
3 Evergreen Trees	(5 per acre)
3 Medium Trees	(5 per acre)
22 Shrubs	(36 per acre)

West Courtyard 16,203 s.f.
 East Courtyard 10,050 s.f.
Total Area 26,253 s.f.
 (0.60 acres)



ADDITIONAL PLANTINGS
PLAN



2018.11.26



CURRY URBAN PROPERTIES

EAST LONGVIEW AVENUE
BLOOMINGTON, INDIANA 47408



CONCEPT PLANT SCHEDULE

	STREET TREE ACER X FREEMANI 'SIENNA' / SIENNA GLEN MAPLE GINKGO BILOBA PRESIDENTIAL GOLD / PRESIDENTIAL GOLD MAIDENHAIR GYMNOCADUS DIOICA 'ESPRESSO' / KENTUCKY COFFEETREE NYSSA SYLVATICA 'GREEN GABLE' / BLACK TUPELO	4	B & B B & B B & B B & B
	SHADE TREE AESCULUS X CARNEA 'BRIOTTI' / RUBY RED HORSECHESTNUT LIRIODENDRON TULIPIFERA 'EMERALD CITY' / EMERALD CITY TULIP TREE QUERCUS LYRATA 'HIGHBEAM' / HIGHBEAM OVERCUP OAK QUERCUS SHUMARDII / SHUMARD RED OAK ULMUS X MORTON STJEWART / COMMENDATION ELM	18	B & B B & B B & B B & B
	COLUMNAR TREE ACER X FREEMANI 'ARMSTRONG' / ARMSTRONG FREEMAN MAPLE CARPINUS BETULUS 'FRANZ FONTAINE' / FRANZ FONTAINE HORNBEAM QUERCUS MACROCARPA 'URBAN PINNACLE' / URBAN PINNACLE OAK QUERCUS ROBUR X BICOLOR 'LONG' / REGAL PRINCE OAK TILIA AMERICANA 'BOULEVARD' / BOULEVARD LINDEN	9	B & B B & B B & B B & B B & B
	ORNAMENTAL TREE AMELANCHER X GRANDIFLORA 'AUTUMN BRILLIANCE' / 'AUTUMN BRILLIANCE' SERVICEBERRY CERCIDIPHYLLUM JAPONICUM / KATSURA TREE CERCIS CANADENSIS / MULTI-STEM EASTERN REDBUD CORNUS X 'RUTBAN' / AURORA FLOWERING DOGWOOD	14	B & B B & B B & B B & B
	EVERGREEN PINUS STROBUS / WHITE PINE	4	B & B
	EVERGREEN SHRUB ILEX GLABRA 'COMPACTA' / COMPACT INKBERRY ILEX VERTICILLATA 'RED SPRITE' / RED SPRITE WINTERBERRY JUNIPERUS X PRITZERIANA 'KALLAY'S COMPACT' / PRITZER JUNIPER	93	#3 #3 #3
	SHRUB TYPE 1 CEANOTHUS AMERICANUS / NEW JERSEY TEA CEPHALANTHUS OCCIDENTALIS 'SUGAR SHACK' / BUTONBUSH SPIRAEA BETULIFOLIA 'TOR' / BIRCHLEAF SPIREA SPIRAEA JAPONICA 'LITTLE PRINCESS' / LITTLE PRINCESS JAPANESE SPIREA	127	#3 #3 #3 #3
	SHRUB TYPE 2 FOTHERGILLA GARDENII 'MI, AIRY' / DWARF WITCHALDER HYDRANGEA QUERCIFOLIA 'ALICE' / ALICE OAKLEAF HYDRANGEA HYDRANGEA QUERCIFOLIA 'RUBY SLIPPERS' / RUBY SLIPPERS HYDRANGEA ITEA VIRGINICA 'MORTON' / SCARLET BEAUTY VIRGINIA SWEETSPICE VIBURNUM DENTATUM 'CHRISTOM' / BLUE MUFFIN ARROWWOOD	132	#3 #3 #3 #3 3 GAL

	SHRUB TYPE 3 AESCULUS PARVIFLORA / BOTTLEBRUSH BUCKEYE CALLICARPA AMERICANA / AMERICAN BEAUTYBERRY PHYSCARPUS OPULENSIS 'SEWARD' / SUMMER WINE NINEBARK VIBURNUM NUDUM 'WINTERHUR' / SMOOTH WITHEROD	92	5 GAL #5 #5 #5
	GRASS SHORT CAREX EBURNEA / BRISTLE-LEAF SEDGE SELERIA AUTUMNALE / AUTUMN HOOR GRASS SPOROBOLUS HETEROLEPSIS / PRAIRIE DROPSIED	297	#1 #1 #1
	GRASS TALL CALAMAGROSTIS X ACUTIFLORA 'KARL FOERSTER' / FEATHER REED GRASS KOeleria MACRANTHA / PRAIRIE JUNEGRASS PANICUM VIRGATUM 'SHENANDOAH' / SWITCH GRASS	259	#1 #1 #1
	SUN PERENNIALS AMSONIA HUBRICHTII / ARKANSAS BLUE-STAR ASTER OBLONGIFOLIUS 'RAYDON'S FAVORITE' / AROMATIC ASTER BAPTISIA X 'MIDNIGHT PRAIRIEBELLES' / MIDNIGHT PRAIRIEBELLES WILD INDIGO ECHINACEA PURPUREA 'POWPOW WILD BERRY' / PURPLE CONEFLOWER HELIUM AUTUMNALE 'MARIACHI SALSA' TM / SNEEWEED IRIS SIBIRICA 'CAESAR'S BROTHER' / CAESAR'S BROTHER SIBERIAN IRIS LIATRIS SPICATA 'KOBOLD' / SPIKE GAYFEATHER PHLOX PANICULATA 'DAVID' / WHITE SUMMER PHLOX RUDBECKIA FULGIDA VAR. SULIVANII 'GOLDSTURN' / BLACK-EYED SUSAN	3,748 SF	#1 15' oc #1 18' oc #1 24' oc #1 15' oc FLAT #1 18' oc #1 15' oc FLAT #1 18' oc
	SHADE PERENNIALS ADANTUM PEDATUM / NORTHERN MAIDENHAIR FERN ANEMONE X HYBRIDA 'HONORINE JOBERT' / JAPANESE ANEMONE AQUILEGIA CANADENSIS / EASTERN COLUMBINE ASTILBE CHINENSIS 'VISIONS IN PINK' / CHINESE ASTILBE ASTILBE CHINENSIS 'VISIONS IN WHITE' / CHINESE ASTILBE BRUNNERA MACROPHYLLA 'JACK FROST' / SIBERIAN BUGLOSS HOSTA X 'BROTHER STEFAN' / PLANTAIN LILY HOSTA X 'SUM AND SUBSTANCE' / PLANTAIN LILY IRIS SIBIRICA 'WHITE SWIRLS' / WHITE SWIRLS SIBERIAN IRIS OSMUNDA CINNAMOMEA / CINNAMON FERN FACELIANDRA TERMINALIS 'GREEN CARPET' / JAPANESE SPURGE POLYGONATUM ODORATUM 'VARIEGATUM' / VARIEGATED SOLOMON'S SEAL TARELLA CORDIFOLIA 'PINK SKYROCKET' / FOAMFLOWER	2,496 SF	#1 24' oc #1 18' oc #1 15' oc #1 18' oc #1 18' oc #1 18' oc #1 24' oc #1 24' oc #1 18' oc #1 18' oc #1 15' oc #1 18' oc
	RAIN GARDEN MIX CAREX ANNECTANS VAR. ANTH / YELLOW FOX SEDGE CAREX FRANKS / FRANKS' SEDGE CAREX VULPHINOIDEA / BROWN FOX SEDGE CHELONE GLABRA / WHITE TURTLE-HEAD IRIS VIRGINICA VAR. SHREVEI / SHREVE'S BLUE FLAG IRIS JUNCUS EFFUSUS / SOFT RUSH JUNCUS TORREYI / TORREY'S RUSH LOBELIA CARDINALIS / CARDINAL FLOWER MIMULUS RINGENS / MONKEYFLOWER	3,164 SF	4POT 12' oc 4POT 12' oc 4POT 12' oc 4POT 12' oc 4POT 12' oc 4POT 12' oc 4POT 12' oc 4POT 12' oc
	TURF TURF SOG / DROUGHT TOLERANT FESCUE BLEND	22,572 SF	SOG

CONCEPT PLANT SCHEDULE

2018.11.26

CURRY URBAN PROPERTIES

EAST LONGVIEW AVENUE
BLOOMINGTON, INDIANA 47408

TEPO
DEVELOPMENT + LIFESTYLE

Smith Brebb & Associates, Inc.
455 S. Clarice Boulevard
Bloomington, Indiana, 47401
Telephone: (317) 338-6536
Web: www.smithbrebb.com
Follow us on Facebook!

RUNDELL ERNSTBERGER ASSOCIATES
LANDSCAPE ARCHITECTURE • PLANNING • URBAN DESIGN • CIVIL ENGINEERING
Interior Design | Landscape | www.runde.com

LUPTON RAUSCH
ARCHITECTURE 4
INTERIOR DESIGN

STREET TREES

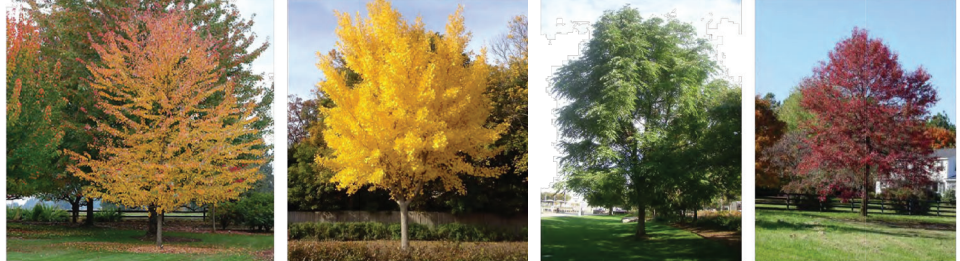

Sienna Glen Maple Presidential Gold Ginkgo Espresso Kentucky Coffeetree Green Gable Black Tupelo

SHADE TREES



Ruby Red Horsechestnut Emerald City Tulip Poplar Highbeam Overcup Oak Shumard Oak Commendation Elm

COLUMNAR TREES



Armstrong Freeman Maple Franz Fontaine European Hornbeam Regal Prince Oak Urban Pinnacle Bur Oak Boulevard American Linden Eastern White Pine

ORNAMENTAL TREES



Autumn Brilliance Serviceberry Katsura Tree Multi-stem Eastern Redbud Aurora Flowering Dogwood

SHRUBS



Compact Inkberry Red Sprite Winterberry Kalley's Compact Juniper Sugar Shack Buttonbush Tor Birchleaf Spirea Little Princess Spirea Scarlet Beauty Sweetspire Wintertur Smooth Withered Alice Oakleaf Hydrangeas Ruby Slippers Oakleaf Hydrangeas American Beautyberry

STREET TREES



Sneezeweed Blue Star Back-eyed Susan Cinnamon Fern Jack Frost Brunnera Foamflower False Indigo Variegated Solomon's Seal Brodiaea Hosta White Swirl Iris Eastern Columbine Kobold Blazingstar Sum & Substance Hosta Japanese Spurge White Phlox Caesar's Brother Iris Northern Maidenhair Fern White Astilbe Purple Coneflower Raydon's Favorite Aromatic Aster Pink Astilbe Honorable Jobert Anemone

GRASSES & RAINGARDEN PLANTS



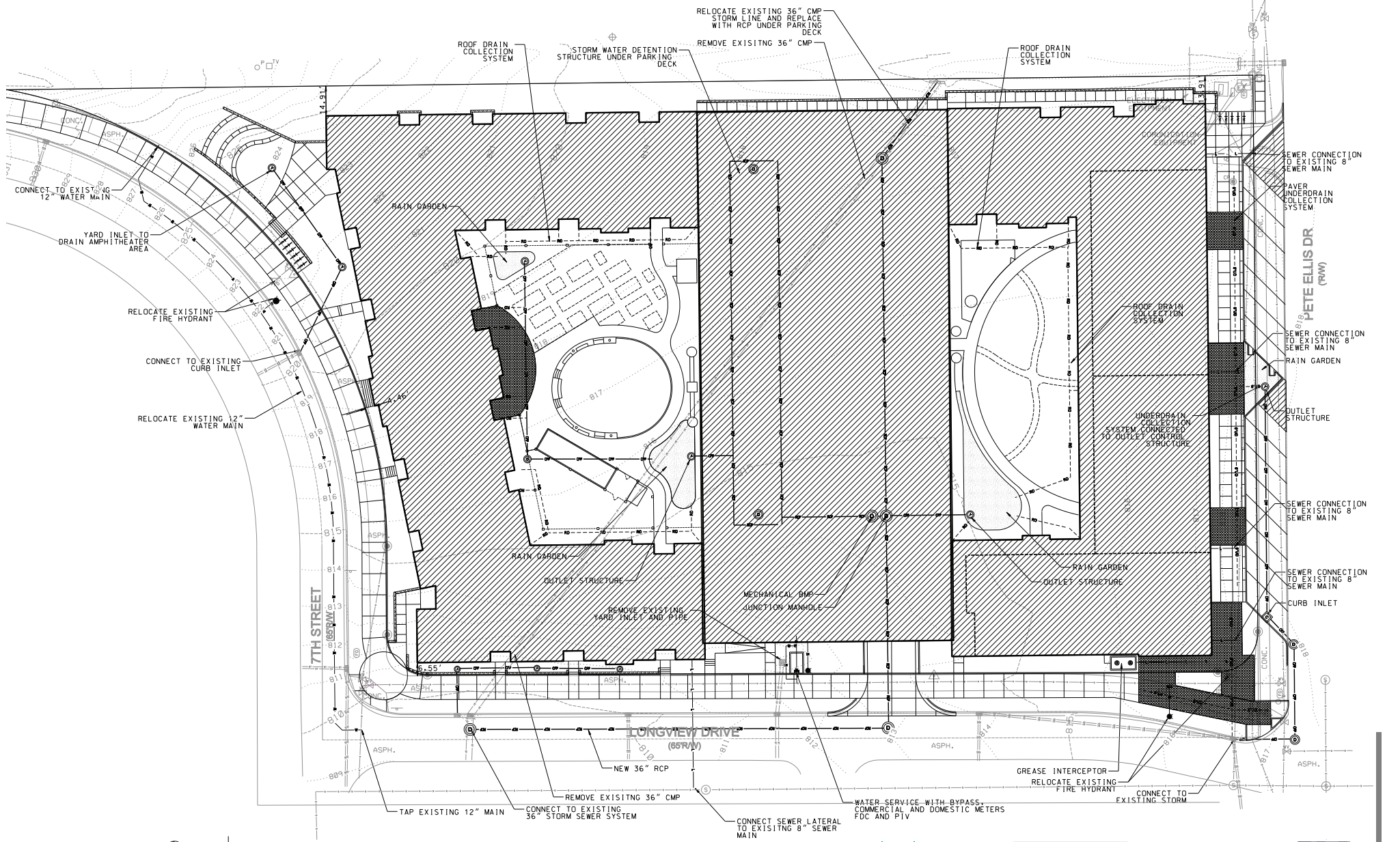

0 10 20 30 40 FEET
SCALE

SITE UTILITY PLAN

2018.11.28

CURRY URBAN PROPERTIES

EAST LONGVIEW AVENUE
BLOOMINGTON, INDIANA 47408

TEEMPO
DEVELOPMENT + LIFESTYLE

Smith Brehob & Associates, Inc.
455 S. Clarissa Boulevard
Bloomington, Indiana 47401
Telephone: (317) 338-6538
Web: www.smithbrehob.com
Follow us on Facebook!

RUNDELL ERNSTBERGER ASSOCIATES
LANDSCAPE ARCHITECTURE • PLANNING • CIVIL ENGINEERING • INTERIOR DESIGN • LIGHTING DESIGN

LUPTON RAUSCH
ARCHITECTURE • INTERIOR DESIGN

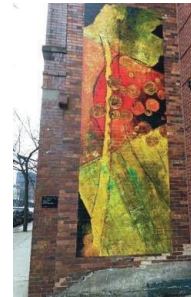
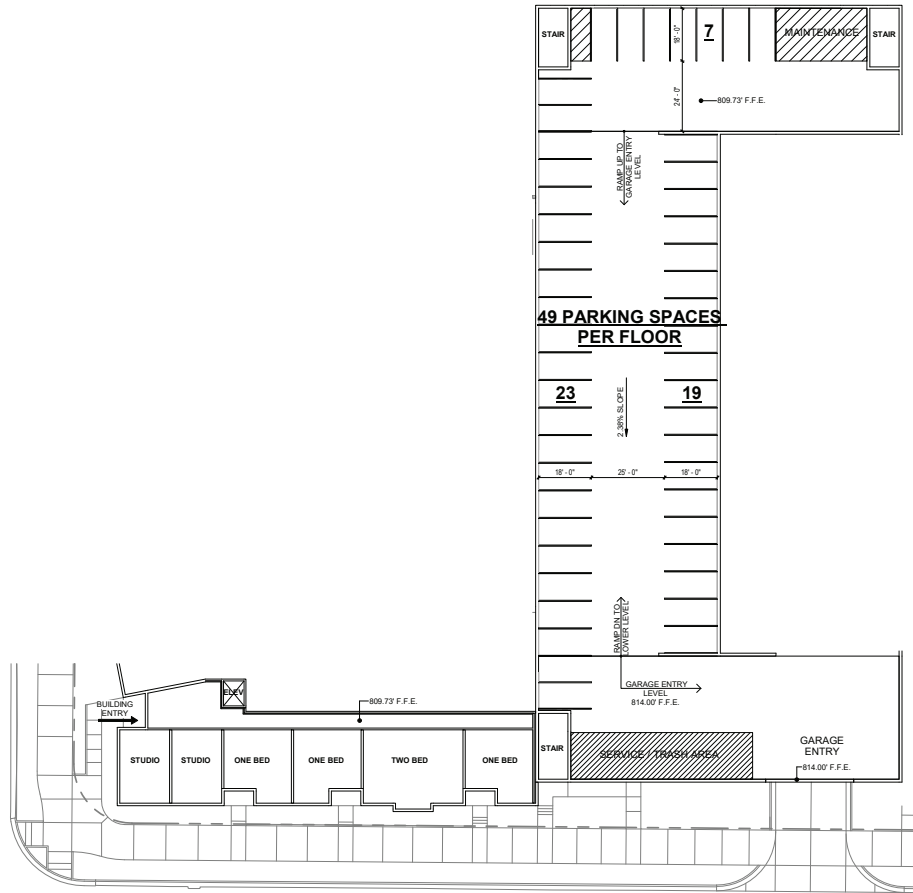

EXTERIOR PRECEDENT IMAGERY



LOWER LEVEL PLAN

2018.11.26

CURRY URBAN PROPERTIES

EAST LONGVIEW AVENUE
BLOOMINGTON, INDIANA 47408

TE|PO
DEVELOPMENT + LIFESTYLE

Smith Brebb & Associates, Inc.
453 S. Clariss Boulevard
Bloomington, Indiana, 47401
Telephone: (317) 338-6536
Web: www.smithbrebb.com
Follow us on Facebook!

RUNDELL ERNSTBERGER ASSOCIATES
LANDSCAPE ARCHITECTURE • PLANNING • URBAN DESIGN • CIVIL ENGINEERING
INTERIORS • LIGHTING • www.rundell.com

LUPTON RAUSCH
ARCHITECTURE 4
INTERIOR DESIGN

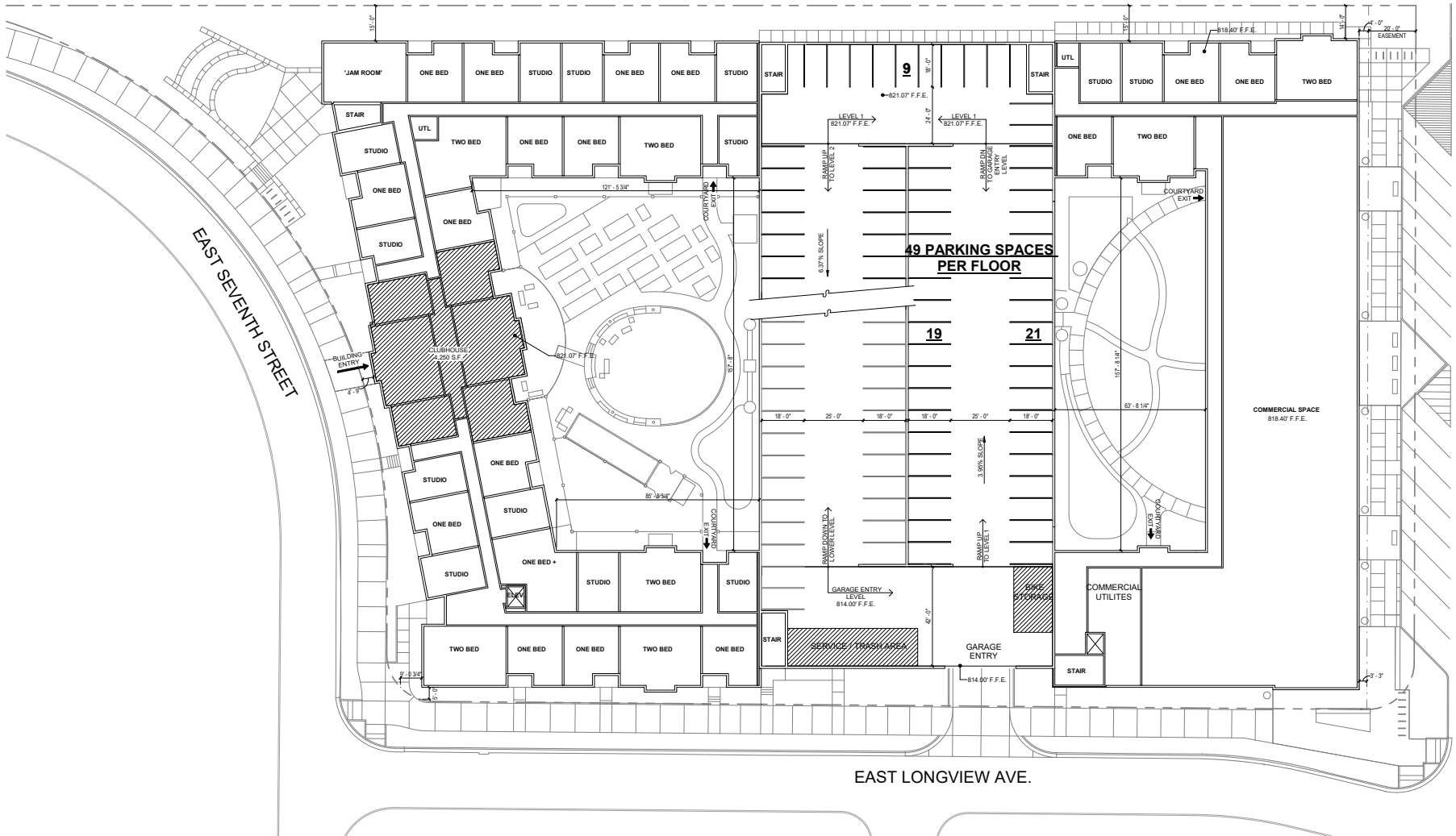

0 5 10 20 30 FEET
SCALE
FIRST FLOOR PLAN

2018.11.26

CURRY URBAN PROPERTIES

EAST LONGVIEW AVENUE
BLOOMINGTON, INDIANA 47408

TEPO
DEVELOPMENT + LIFESTYLE

Smith Brehob & Associates, Inc.
453 S. Clariss Boulevard
Bloomington, Indiana 47401
Telephone: (317) 336-6536
Web: www.smithbrehob.com
Follow us on Facebook!

RUNDELL ERNSTBERGER ASSOCIATES
LANDSCAPE ARCHITECTURE • PLANNING • URBAN DESIGN • CIVIL ENGINEERING
Interior Design | Construction | www.rea.com

LUPTON RAUSCH
ARCHITECTURE + INTERIOR DESIGN

NORTH PETE ELLIS DRIVE

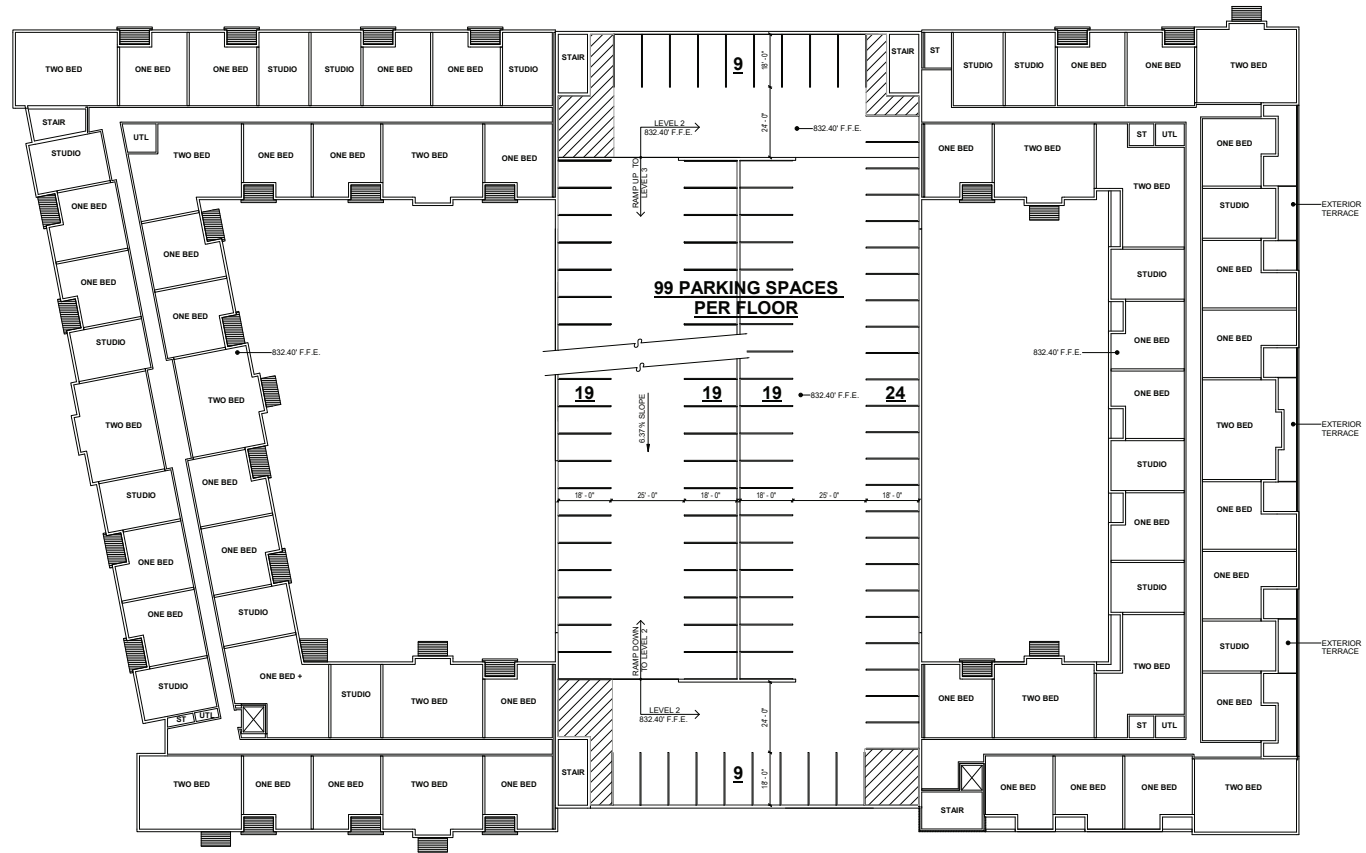

SECOND FLOOR PLAN

2018.11.26

CURRY URBAN PROPERTIES

EAST LONGVIEW AVENUE
BLOOMINGTON, INDIANA 47408

TEPO
DEVELOPMENT + LIFESTYLE

Smith Brebb & Associates, Inc.
453 S. Clariss Boulevard
Bloomington, Indiana 47401
Telephone: (317) 336-6536
Web: www.smithbrebb.com
Follow us on Facebook!

RUNDELL ERNSTBERGER ASSOCIATES
LANDSCAPE ARCHITECTURE • PLANNING • URBAN DESIGN • CIVIL ENGINEERING
Indianapolis | Louisville | www.rea.com

LUPTON RAUSCH
ARCHITECTURE + INTERIOR DESIGN

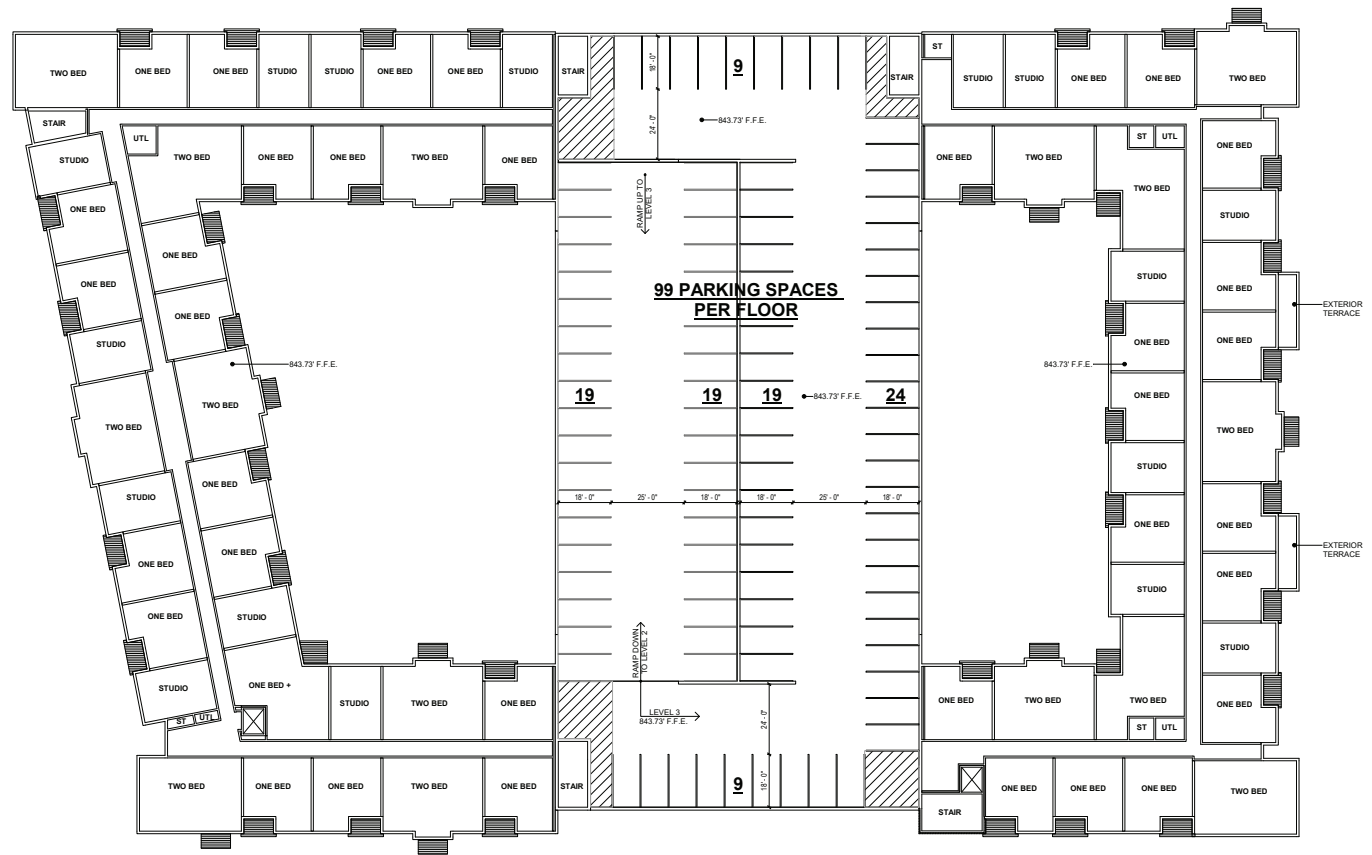

THIRD FLOOR PLAN

2018.11.26

CURRY URBAN PROPERTIES

EAST LONGVIEW AVENUE
BLOOMINGTON, INDIANA 47408

TE M P O
DEVELOPMENT + LIFESTYLE

Smith Brebob & Associates, Inc.
453 S. Clarissz Boulevard
Bloomington, Indiana, 47401
Telephone: (317) 336-6536
Web: www.smithbrebob.com
Follow us on Facebook!

RUNDELL ERNSTBERGER ASSOCIATES
LANDSCAPE ARCHITECTURE • PLANNING • URBAN DESIGN • CIVIL ENGINEERING
Indianapolis | Louisville | www.rea.com

LUPTON RAUSCH
ARCHITECTURE + INTERIOR DESIGN

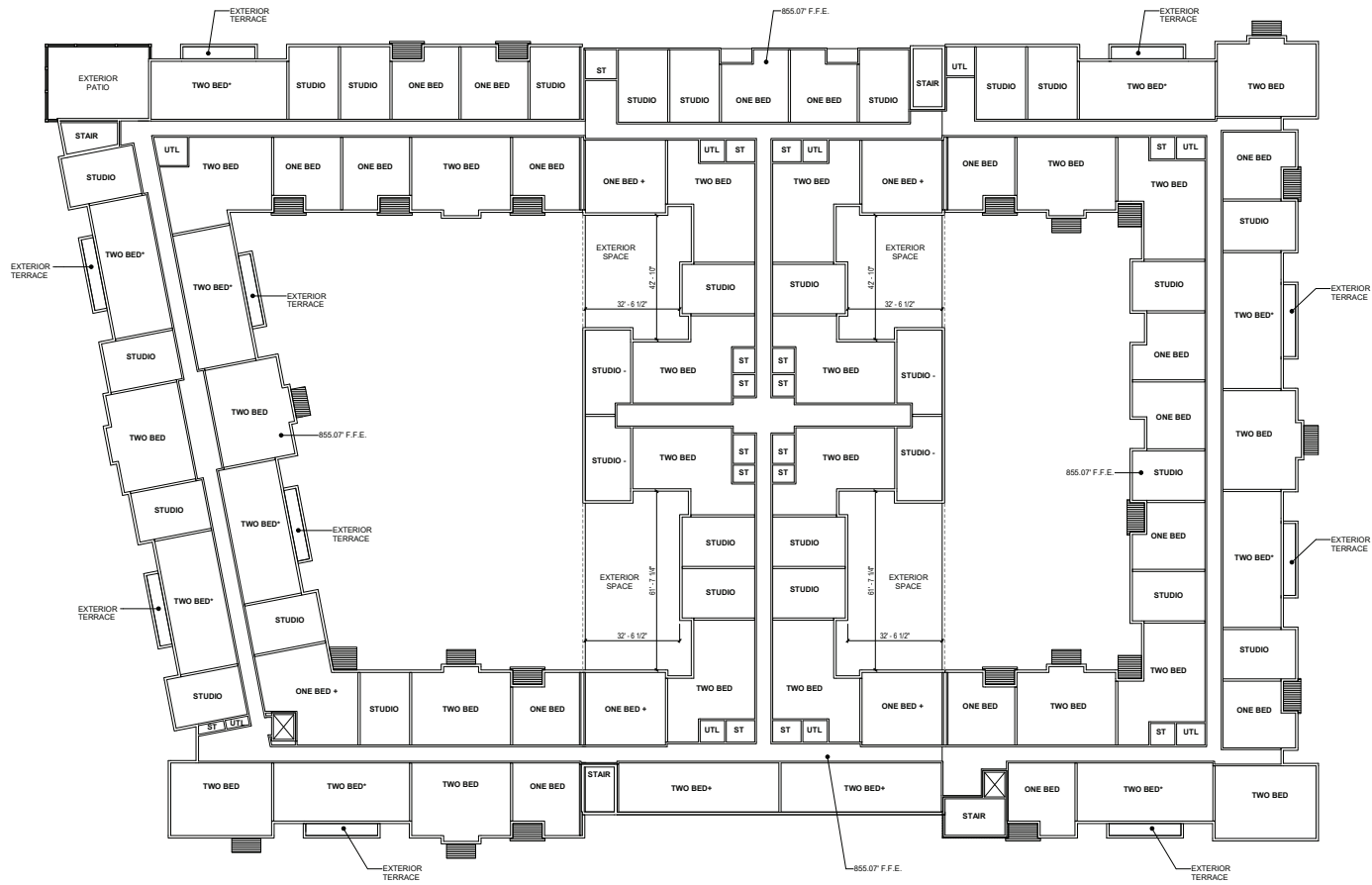

FOURTH FLOOR PLAN

2018.11.26

CURRY URBAN PROPERTIES

EAST LONGVIEW AVENUE
BLOOMINGTON, INDIANA 47408





EAST ELEVATION - PETE ELLIS DRIVE



SOUTH ELEVATION - LONGVIEW AVENUE



WEST ELEVATION - SEVENTH STREET



NORTH ELEVATION



COLORED ELEVATIONS

2018.11.26

CURRY URBAN PROPERTIES

EAST LONGVIEW AVENUE
BLOOMINGTON, INDIANA 47408

TEMPO
DEVELOPMENT + LIFESTYLE



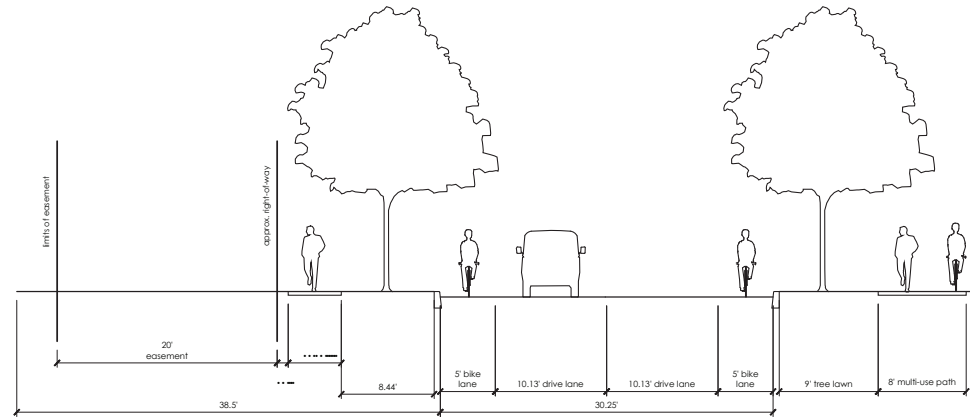

EXISTING CONDITIONS

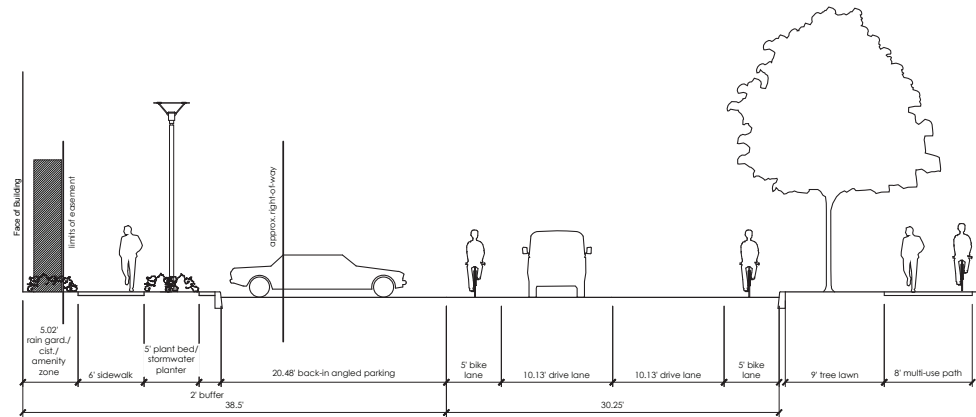

PROPOSED CROSS SECTION



PETE ELLIS CROSS SECTIONS

2018.11.26

CURRY URBAN PROPERTIES

EAST LONGVIEW AVENUE
BLOOMINGTON, INDIANA 47408



**BLOOMINGTON PLAN COMMISSION
STAFF REPORT
Location: 4201 E. Hagan Street**

**CASE #: PUD-38-18
DATE: March 18, 2019**

PETITIONER: IU Credit Union
PO Box 368, Bloomington

CONSULTANT: Strauser Construction
4213 E 3rd Street, Bloomington

REQUEST: The petitioner is requesting PUD final plan approval to allow a 13,284 square foot commercial building.

BACKGROUND:

Area: 3.13 acres
Current Zoning: PUD
Comp Plan Designation: Urban Corridor
Existing Land Use: Undeveloped
Proposed Land Use: Commercial
Surrounding Uses: North – Commercial
East – Commercial
South – Multi-family Residential
West – Commercial

REPORT: The property is located at 4201 E. 3rd Street and is within the Baker Stephens PUD (PUD-19-84). Surrounding properties to the west, east, and south are also within the Baker Stephens PUD, and the properties to the north are zoned Commercial General (CG). The Baker Stephens PUD was approved with a specific list of permitted uses, but no specific development standards were approved. The Plan Commission has used the Commercial Arterial district standards to review previous site plans for adjacent properties. The property has frontage on SR46 to the north, Hagan Street to the south, and Park Ridge Road to the east. There are no environmental features on the site or any structures.

The petitioner is requesting PUD final plan approval for a 13,000 sq. ft. commercial building with 72 parking spaces for an Indiana Credit Union office building. With the new construction on this lot the petitioner will be installing a missing segment of multi-use path along the SR 46 frontage as well as new sidewalks along Hagan St and Park Ridge Rd. New landscaping will also be installed on the site to meet current code requirements. The proposed building will face SR 46 and will have a sidewalk connecting the building to SR 46. The parking area has been shown behind the building as required. The proposed building will be used as entirely office space and there will be no consumer banking component. There will be 66 work stations with a capacity to increase that to 82 work stations.

FINAL PLAN ISSUES:

Parking: The petitioner is proposing to provide 72 parking spaces. The UDO allows for a maximum of one parking space per 300 square feet of floor area, which based on the size of this

building would only allow 44 parking spaces maximum. This building will have 66 specialized workstations, in addition to training areas for outside staff. Since this is located within a PUD, the Plan Commission has the ability to allow deviations from the UDO standards. Given the specific design of this building and need, the Department is recommending that the Plan Commission approve the requested 72 parking spaces. This approval would be for this use and building design only, any future office uses would need to meet UDO requirements unless otherwise approved.

Access: The parking area will be accessed by one drivecut on Hagan Street to the south. No drivecuts on SR 46 are proposed.

Development Standards: The PUD did not have specific development standards and the commercial standards that were in place at the time. The Department has therefore used the current Commercial Arterial district development standards to review this petition. The proposed site plan meets all of the current development standards.

Architecture: The building will be finished with a limestone front and areas of EIFS. The roof will be a standing seam metal. All of the proposed finishing materials are allowed. A pedestrian entrance has been included along the front along with a sidewalk connecting the front door to the SR 46 multi-use path.

Pedestrian Facilities/Streetscape: With this petition there would be a missing segment of multi-use path installed along the SR 46 frontage. A 5' wide concrete sidewalk and 5' wide tree plot will be installed along the Hagan Street and Park Ridge Road frontages.

Utilities: The site is well served by existing utilities and while no problems have been highlighted so far, a full utility plan has not been approved and will be reviewed with a grading permit.

20.04.090 PUD Final Plan- The UDO does not list specific findings criteria for PUD Final Plans, but does list what items shall be considered by the Plan Commission in a review:

(A) The written statement and supportive material submitted by the petitioner;

Recommended Finding: The petitioner has provided all required materials.

(B) The PUD District Ordinance;

Recommended Finding: The proposed petition meets the original PUD District Ordinance guidance and the Department has used the current Commercial Arterial development standards for any items that were not addressed in the district ordinance.

(C) The Preliminary Plan;

Recommended Finding: The approved preliminary plan showed only a conceptual layout of areas with no real specific standards. The proposed site plan is in conformance with the general layout shown with the preliminary plan.

(D) The Final Plan;

Recommended Finding: The petition is the Final Plan for the site.

(E) Any commitments or conditions of approval attendant to prior approvals;

Recommended Finding: There were no previous commitments or conditions that were imposed on the final plan approval.

(F) Any applicable section of the Unified Development Ordinance;

Recommended Finding: The petition is subject to the current CA zoning district standards of the UDO for architecture, height, and environmental standards as well as any other current standards in the UDO that were lacking in the original PUD.

(G) Additional information as may be required by the Plan Commission to evaluate the application.

Recommended Finding: No additional information has so far been requested by the Plan Commission for this site.

ENVIRONMENTAL COMMISSION RECOMMENDATION:

1.) Add additional bicycle parking spaces.

STAFF RESPONSE: Although not required, since additional vehicular parking spaces are being requested, the Department does not feel that this is an unreasonable request and recommends that at least 2 extra bicycle parking spaces should be added.

CONCLUSION: This petition follows the general outline of the approved preliminary plan while at the same time meeting our current regulations. This site was originally shown as being completely covered with a building and parking areas and the proposed final plan is an improvement on the previous preliminary site plan.

RECOMMENDATION: The Department recommends approval of the proposed site plan and with the following conditions of approval:

1. This site plan approval and number of parking spaces is for this specific user only. Any new office use on this site must meet zoning standards in place at that time unless otherwise approved by the Plan Commission.
2. A lighting plan has not been reviewed and must be submitted and approved prior to issuance of a building permit.
3. An additional 2 bicycle parking spaces must be added to the site plan.



City of Bloomington
Bloomington Environmental Commission

MEMORANDUM

Date: March 18, 2019
To: Bloomington Plan Commission
From: Bloomington Environmental Commission
Subject: PUD-38-18: I.U. Credit Union Operations Building
4201 E. Hagan Street

The purpose of this memo is to convey the environmental concerns and recommendations of the Environmental Commission (EC) with the hope that action will be taken to enhance its environment-enriching attributes. The EC reviewed the petition and offers the following comments and requests for your consideration.

ISSUES OF SOUND ENVIRONMENTAL DESIGN

1.) The EC and many others in Bloomington believe that the paradigm of an automobile-centric society must change. However, no one can expect people to simply stop driving automobiles if there are no reasonable alternative means of transportation in place. Such an alternative likely won't be one single new mode of transportation, but many, including continuing the use of automobiles in a more limited capacity. Therefore, the EC recommends that more than the minimum number of bicycle spaces be provided. Encouraging cycling when possible, to reduce vehicle miles traveled is one way to reduce our greenhouse gas emissions.

EC RECOMMENDATIONS:

1.) Add additional bicycle parking spaces.

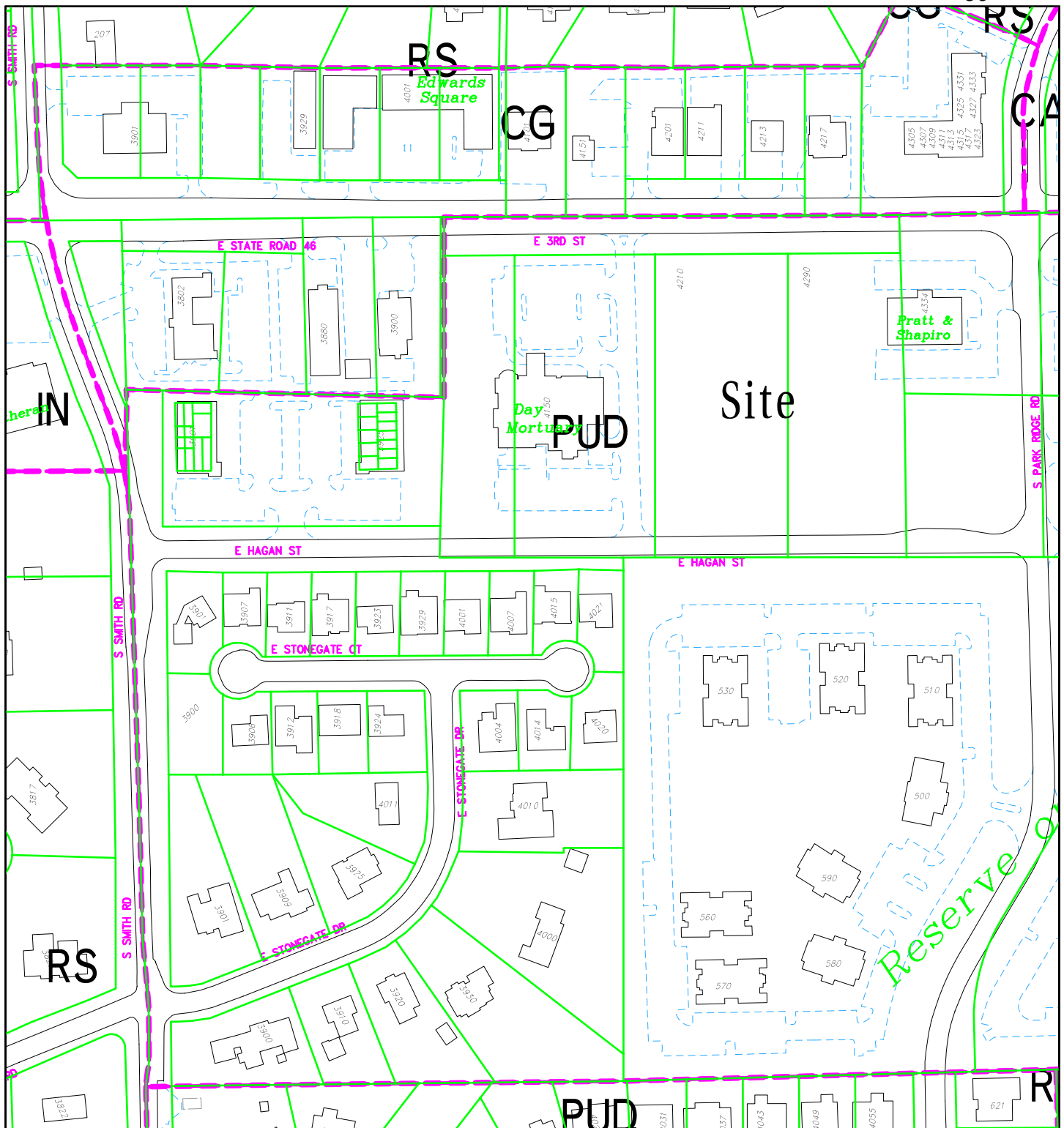

PUD-38-18 IU Credit Union
 4201 E Hagan Street
 Plan Commission
 Site Location, Zoning, Parcels

By: greulice
 15 Mar 19

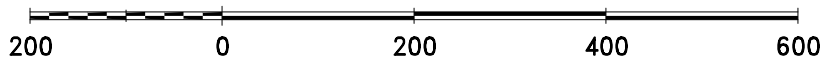

City of Bloomington
 Planning & Transportation

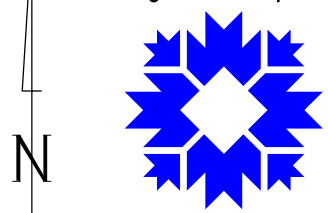

Scale: 1" = 200'

For reference only; map information NOT warranted.

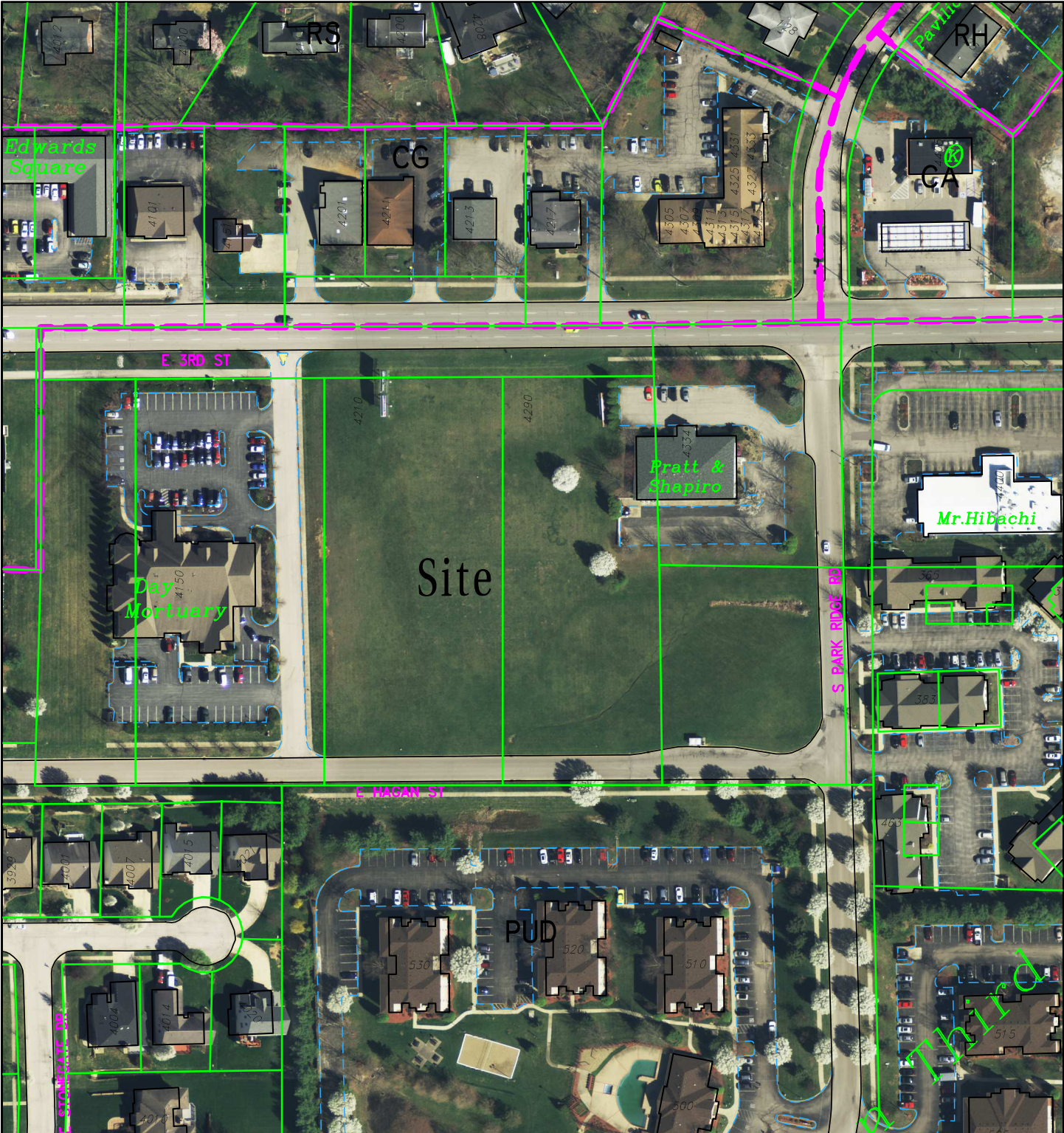

By: greulice
15 Mar 19

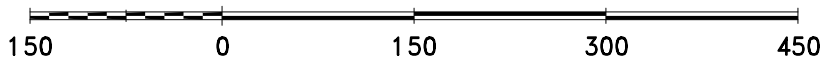

City of Bloomington
Planning & Transportation

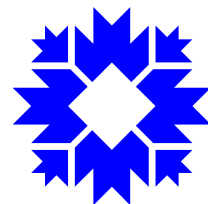

Scale: 1" = 150'

For reference only; map information NOT warranted.



ROWLAND | DESIGN

702 North Capitol Avenue
Indianapolis, Indiana 46204

p 317 636-3980
f 317 263-2073

www.rowlanddesign.com

28 November 2018

Re: Green Initiatives in Proposed Building at 4201 E. Hagan Street

At Rowland Design we believe that good design always incorporates environmental sensitivity for our planet and community. We are not seeking LEED certification for this building but we always design to strong environmental standards as a fundamental part of our services. Below is a list of how we address what we consider to be the most important issues in green development. While specific fixtures, equipment, and construction methods are not yet detailed, we will meet requirements and strive to exceed them as we do in all of our work.

1. The project addresses **regional and local context and connectivity** by being located within an already dense mixed-use neighborhood that is served by transit and pedestrian infrastructure rather than on an ex-urban site. All edges of the site will receive new sidewalks and we are creating a new pedestrian path specifically linking the existing bus stop at the southeast corner of the site to our front door. Employees will have easy nearby access to local businesses for lunch breaks and errands. A significant portion of the site will remain as open green space, both for personal enjoyment and for stormwater mitigation. Bike parking and compact car parking will be included as will exterior patio spaces for employee use. We also propose limestone on the façade in keeping with the tradition of the most-loved local material.
2. The building incorporates **green site development** with careful consideration of the overall use of the lot. The site is slightly sloped and we are locating the building to minimize cut and fill that would disturb large areas of the site. Stormwater retention is accomplished through a new retention basin that will be landscaped with native, low-maintenance plants and trees. The parking and building hardscape areas will feature landscape plantings to soften the exterior and allow permeable areas within the development. Site and exterior building lighting will use lowlight pollution fixtures.
3. **Green building techniques** used on the building include extensive use of daylight. The light monitor running the length of the roof will allow daylight to be the primary form of light during the workday. All windows have exterior-mounted sunshades to mitigate heat gain. Light fixtures will be LED, plumbing fixtures will meet low-flow water efficiency standards, and all appliances will meet Energy Star compliance. The HVAC system is not yet finalized but will be high efficiency with multiple user zones and energy-saving controls.

We look forward to answering any questions about the proposed building for IU Credit Union.



ROWLAND | DESIGN

702 North Capitol Avenue
Indianapolis, Indiana 46204

p 317 636-3980
f 317 263-2073

www.rowlanddesign.com

4 March 2019

City of Bloomington Plan Commission
401 N. Morton Street
Bloomington IN 47403

Re: Petitioner's Statement
4201 E. Hagan Street
Bloomington Indiana 47401

Dear Commission Members:

This statement describes a proposed new office building for the long-time Bloomington business IU Credit Union. The IU Credit Union has been serving Bloomington residents for over 60 years and seeks to continue their commitment here by building a new business and operations center on their property located at 4201 E. Hagan Street. The site is located on the south side of East Third Street and is bounded by Hagan Street to the south and South Park Ridge Road to the east and is part of the Baker Stephens PUD.

1. General and Proposed Use: The proposed new building is a one-story office building for employees of the IU Credit Union who will perform online and telephone customer service, IT, and general business tasks. The facility also includes support spaces such as meeting rooms and a staff lunchroom. This business use meets the original 1984 approved compatible uses list for the PUD that includes Professional Offices.
2. Architecture and Materials: The building is a one-story structure with a mixture of limestone, metal panel, and EIFS cladding on the walls. The roof is standing seam metal. Windows are either clad or fiberglass. Mechanical units will be located both on the roof and at grade near the private road on the east of the site, behind decorative screens in both cases.
3. Height and size: The proposed building is 13,300 SF and the highest point of the roof will be no higher than 26' above the ground level (at approximate elevation +869).
4. Access: The main proposed vehicle access is from Hagan Street to the employee parking lot with a possible future service access from the shared private road between this site and the neighbor to the west. No vehicular access will be added on East Third Street.
5. Landscaping and site development: The site will offer employee parking at slightly higher than code required levels to meet the requirements of building occupancy. We propose new sidewalks to be built along Third Street, East Hagan Street, and Park Ridge. A pedestrian path will also be built from the existing bus stop on Hagan to connect to the building. Landscaping will be in compliance with requirements and will feature native species. The retention requirements for the site will be met with

a retention basin on the south portion of the lot, beyond the location of any proposed future additions to the building.

6. Scale on the street corridor: The proposed building is similar in height scale to its neighbors to the east and west. While the building offers a windowed façade at Third Street, the footprint is turned so that the widest parts of the building are angled away from the Third Street corridor, reducing the apparent mass along the most visible portion of the site.
7. Sustainable Design Initiatives: Please see attached supplement describing the sustainable initiatives incorporated into the project.

We look forward to answering any questions about the proposed building for IU Credit Union.

Sincerely,

A handwritten signature in black ink, appearing to read 'Donna Sink', with a long horizontal line extending to the right.

Donna Sink AIA

March 4, 2019

City of Bloomington Plan Commission
401 N. Morton Street
Bloomington, IN 47403

**Re: Letter of Justification for Parking Space Count
4201 E. Hagan Street
Bloomington, IN 47401**

Dear Commission Members:

Thank you for reviewing IU Credit Union's plans for our Operations Building designed to meet our space needs for employees, training, and disaster recovery. The project's scope necessitates this request for 72 parking spaces to accommodate employees assigned to the site and those attending regular training sessions. The following comments are offered in support of our request.

- The building occupant load is 108. The work space is designed for 66 work spaces with the ability to reconfigure with future growth. The collaborative areas provide space for an additional 16 workstations increasing to 82 the total number of potential work spaces.
- We expect to have additional employees present for training in addition to visitors and vendors on a routine basis.
- The building will serve as a disaster recovery site for IU Credit Union operations. A natural gas generator will power the entire building if we experience an electrical service disruption. In the event of a disaster, emergency, or significant issue at another Credit Union facility, employees will be reassigned to this building.
- IUCU has experienced an average increase in assets of 6% over the past four years. We expect similar future growth and within five years assets will be 30% higher with additional employees required to meet the needs of our thriving institution.

The scope of the project includes significant landscaping, a new multi-use path, sidewalks, replacement of the existing bus stop, and removal of the billboards along Third Street. The site plan includes 1.21 acres of green space.

IU Credit Union is committed to serving current and future members. We are proud of the strong positive influence we have had on the Bloomington community for over 60 years. This project will enable continued growth in members and employees in the community we serve.

Thank you for your consideration of our request.

Sincerely,

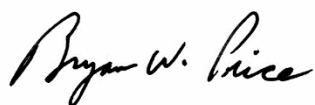
A handwritten signature in black ink that reads "Bryan W. Price". The signature is written in a cursive, flowing style.

Bryan W. Price
President & CEO

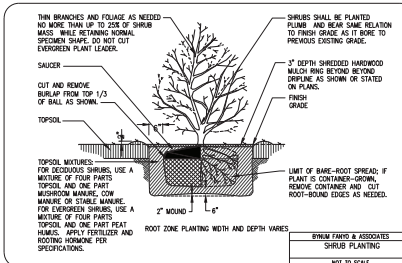
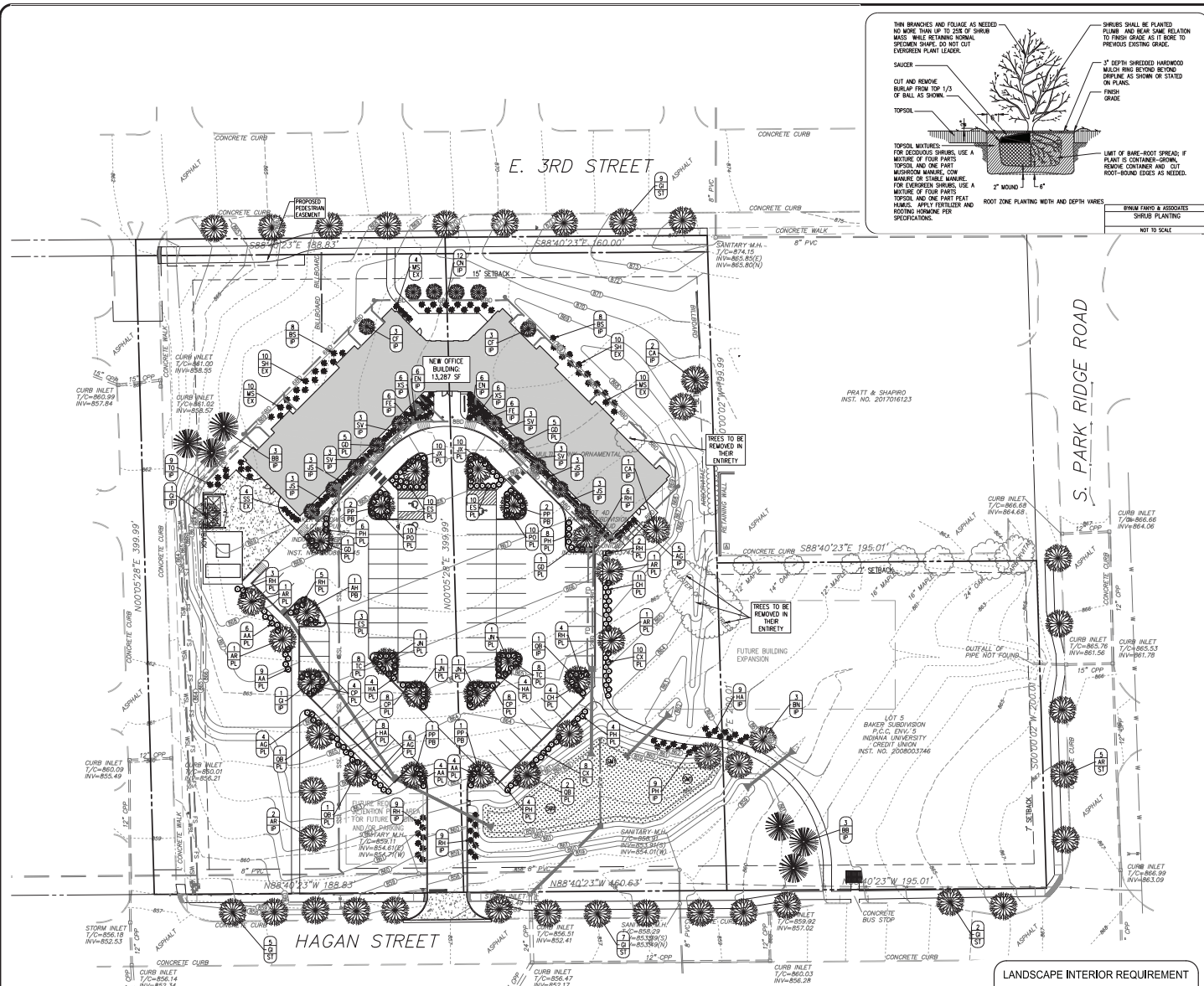

PLANT LIST & LEGEND

LARGE CANOPY DECIDUOUS TREES					
LEGEND KEY	BOTANICAL NAME	COMMON NAME	QTY	SIZE & CONDITION	
JN	QUERCUS MACROCARPA	BUR OAK	4	2" CAL. B & B	
Q	QUERCUS RUBRA	RED MAPLE	4	2" CAL. B & B	
D	TILIA AMERICANA	AMERICAN LINDEN	2	2" CAL. B & B	
FR	FRAXINUS	SHIMP WHITE OAK	2	2" CAL. B & B	
FR	TAXODIUM DISTICHUM	BALD CYPRESS	1	2" CAL. B & B	
MI	MILVUS SPICATA	WATER BUTTERNUT	1	2" CAL. B & B	
SMALL / MEDIUM DECIDUOUS TREES					
LEGEND KEY	BOTANICAL NAME	COMMON NAME	QTY	SIZE & CONDITION	
CF	CORNUS TORIDA	FLORING DOGWOOD	2	2" CAL. B & B	
CA	SAULNIERIA CANADENSIS	SAULNIER DOGWOOD	12	18" HOODH+	
BN	BETULA PLATYPHYLLA	COLUMBIAN PAPERBARK BIRCH	6	2" CAL. B & B	
BN	BETULA NIDA	SWAMP BIRCH	12	2" CAL. B & B	
EXTRA PLANTINGS					
LEGEND KEY	BOTANICAL NAME	COMMON NAME	QTY	SIZE & CONDITION	
EN	ECHEMACIA PURPUREA	PURPLE CONEFLOWER	12	18" HOODH+	
RS	RUSSOYA NIDA	BLACK-LEAFED SOYAN	12	18" HOODH+	
SE	SCHIZACHNEM SUPRIMUM	LITTLE BLUESTEM	12	1" GALLON CONTAINER	
SE	SCYRIPUS CAPENSIS	BLUETOOTH GRASS	12	1" GALLON CONTAINER	
MS	MATRICARIA SIBIRICA	OSYRIS FERN	24	1" GALLON CONTAINER	
MS	SORGHALUM HELIOPSIS	SORGHUM HELIOPSIS	24	1" GALLON CONTAINER	
DECIDUOUS SHRUBS - PARKING LOT PERIMETER					
LEGEND KEY	BOTANICAL NAME	COMMON NAME	QTY	SIZE & CONDITION	
PH	PRUNUS PAVIA	SAND CHERRY	22	18" HOODH+	
PO	PALEXIA TERRESTRIS	RED TWIG DOGWOOD	18	18" HOODH+	
AZ	ANDROMEDA OLEANDRIS	BIG BLEUETIA	18	18" HOODH+	
HA	HYDRANGEA ARBORESCENS	WEDDING HYDRANGEA	4	18" HOODH+	
AA	ARJUNIA ARBORESCENS	BLACK CHERRYBERRY	24	18" HOODH+	
SA	SALICORNIA PERUVIANA	SALICORNIA	18	18" HOODH+	
EVERGREEN SHRUBS - PARKING LOT PERIMETER					
LEGEND KEY	BOTANICAL NAME	COMMON NAME	QTY	SIZE & CONDITION	
PH	PRUNUS PAVIA	SAND CHERRY	22	18" HOODH+	
CA	CALLUNA VULGARIS	FALSE HEATH	18	18" HOODH+	
TC	TAXUS CANADENSIS	CANADIAN YEW	18	18" HOODH+	
AT	ARISAEMA OREGANICUM	WILD TERNUTIA	18	18" HOODH+	
ES	ERICA CARNEOLINA	WAX HEATH	20	18" HOODH+	
CP	CORONILLA ALBA	WAX HEATH	20	18" HOODH+	
DECIDUOUS SHRUBS - INTERIOR PLANTINGS					
LEGEND KEY	BOTANICAL NAME	COMMON NAME	QTY	SIZE & CONDITION	
PH	PRUNUS PAVIA	SAND CHERRY	9	18" HOODH+	
ON	ONOCLEA STRIATA	WAX HEATH	12	18" HOODH+	
SH	SCHIZACHNEM SUPRIMUM	BLUETOOTH GRASS	12	18" HOODH+	
PH	PRUNUS PAVIA	SAND CHERRY	9	18" HOODH+	
INTERIOR PLANTINGS EVERGREEN TREES					
LEGEND KEY	BOTANICAL NAME	COMMON NAME	QTY	SIZE & CONDITION	
BB	PIEA PINUS	BLUE SPRUCE	6	6" HOODH+	
EVERGREEN SHRUBS - INTERIOR PLANTINGS					
LEGEND KEY	BOTANICAL NAME	COMMON NAME	QTY	SIZE & CONDITION	
PH	PRUNUS PAVIA	SAND CHERRY	9	18" HOODH+	
ON	ONOCLEA STRIATA	WAX HEATH	12	18" HOODH+	
SH	SCHIZACHNEM SUPRIMUM	BLUETOOTH GRASS	12	18" HOODH+	
PH	PRUNUS PAVIA	SAND CHERRY	9	18" HOODH+	

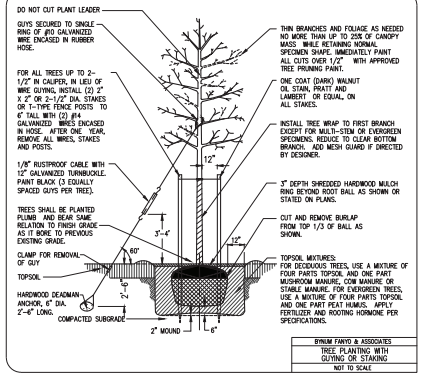

LANDSCAPE INTERIOR REQUIREMENT

TOTAL AREA THAT IS NOT COVERED BY IMPROVEMENTS: 52,783 SF (1.21 AC)

REQUIRED INTERIOR TREE PLANTINGS: 11 CANOPY TREES, 4 EVERGREEN TREES, 4 MEDIUM/SMALL TREES

TOTAL LOT AREA: 136,155 SF (3.13 AC)

REQUIRED SHRUB PLANTINGS: 43 EVERGREEN SHRUBS, 42 DECIDUOUS SHRUBS

NOTE TO CONTRACTOR

CONTRACTOR SHALL VERIFY ALL UTILITY LOCATIONS & DEPTHS AND NOTIFY ENGINEER OF ANY INCONGRUITIES IN LOCATION OR ELEVATION OR ANY CONFLICTS PRIOR TO & AFTER ANY EXCAVATION. NO PAYMENT SHALL BE MADE TO CONTRACTOR FOR UTILITY DESTRUCTION OR UNDERGROUND CHANGES REQUIRED DUE TO CONFLICTING ELEVATIONS.

revisions:

1	ARCHITECTURE
2	CIVIL ENGINEERING
3	PLANNING

blomhogan, Indiana
(812) 338-2990 (Fax)

BYNUM FANTO & ASSOCIATES, INC.

528 North Walnut Street
(812) 332-1030

LETITNEY S. FANTO
No. 18263
REGISTERED PROFESSIONAL ENGINEER
STATE OF INDIANA

certified by: [Signature]

PROPOSED

IU CREDIT UNION OPERATIONS CENTER

**EAST 3RD STREET
BLOOMINGTON, INDIANA 47401**

title: SITE LANDSCAPE PLAN

designed by: DJB
drawn by: DJB
checked by: JSF
sheet no: C501
project no: 401844

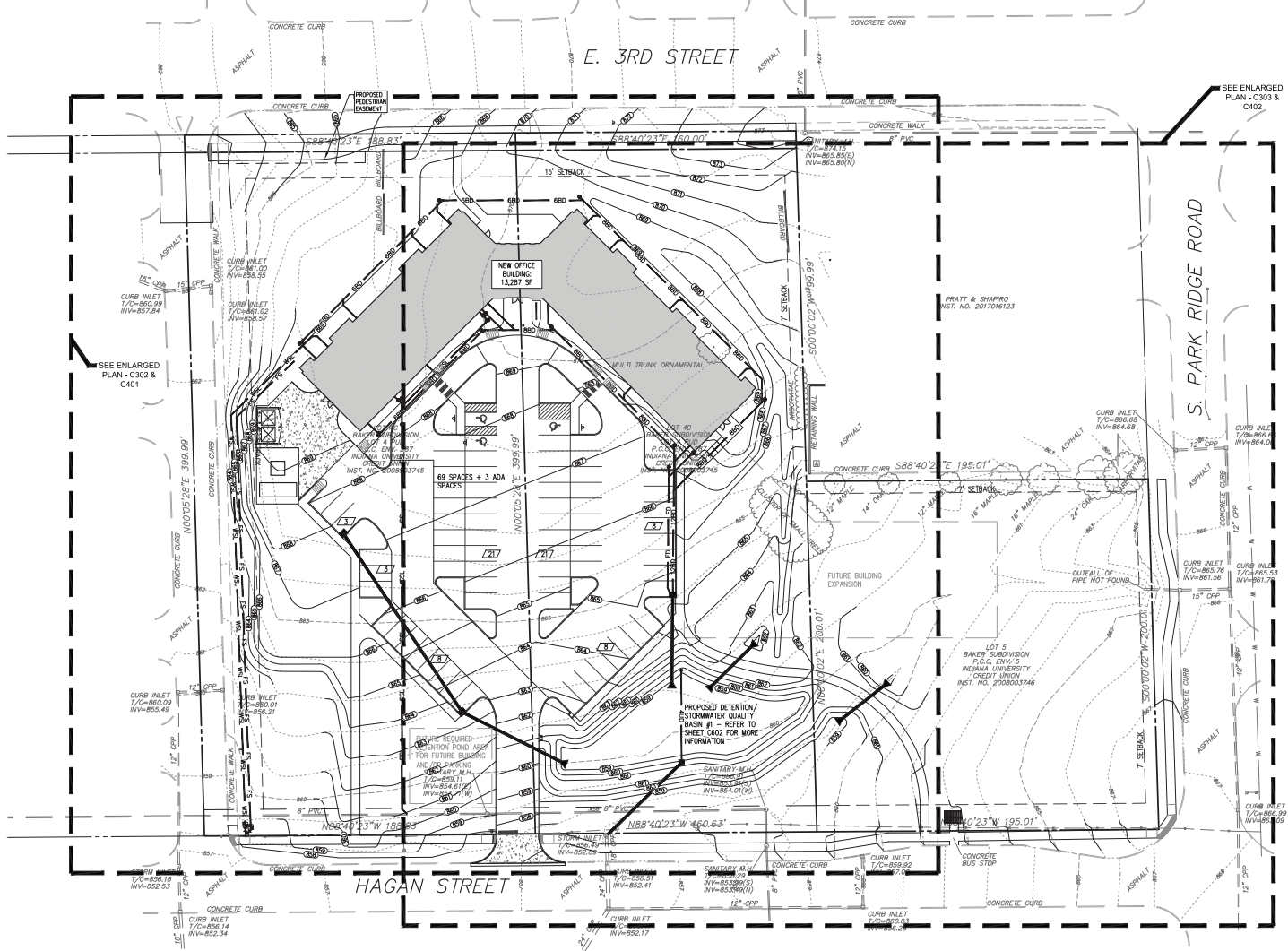

DIAL '811' BEFORE YOU DIG
 PER INDIANA STATE LAW ICS-1-26.
 IT IS AGAINST THE LAW TO EXCAVATE WITHOUT NOTIFYING THE UNDERGROUND LOCATION SERVICE TWO (2) WORKING DAYS BEFORE COMMENCING WORK.

NOTE:
 GEOTECHNICAL REPORT DEVELOPED BY ALT & WITZIG, 4105 WEST 99TH STREET, CARMEL, INDIANA 46032 AND CERTIFIED BY BRIAN A. WIRT ON JANUARY 4, 2019 IS BY REFERENCE MADE A PART OF THESE PLANS.

EXISTING LEGEND

EXISTING FENCE	— — — — —
EXISTING WATER LINE	X W
EXISTING OVERHEAD UTILITY LINES AND/OR OVERHEAD ELECTRICAL LINES	XOHU
EXISTING GAS LINE	GAS
EXISTING CONTOUR	---X---
EXISTING SANITARY SEWER MAIN	== O
EXISTING STORM SEWER AND INLET	== I
PROPERTY LINE	- - - - -

- NOTES TO CONTRACTOR:**
1. ALL PROJECTS WILL REQUIRE A PRE-CONSTRUCTION MEETING WITH THE CITY OF BLOOMINGTON UTILITIES PRIOR TO THE START OF CONSTRUCTION. THE CONTRACTOR AND/OR DEVELOPER MUST CONTACT THE UTILITIES TECHNICIAN AT (812)349-3633 TO SCHEDULE THE MEETING.
 2. THE CONTRACTOR SHALL ALSO CONTACT THE CITY OF BLOOMINGTON PLANNING AND TRANSPORTATION DEPARTMENT AT 812-349-3423 FOR A PRE-CONSTRUCTION MEETING BEFORE ANY CONSTRUCTION ACTIVITY HAS BEGUN.
 3. CONTRACTOR SHALL NOTIFY THE CITY OF BLOOMINGTON UTILITIES ENGINEERING DEPARTMENT ONE (1) WORKING DAY PRIOR TO CONSTRUCTION OF ANY WATER, STORM OR SANITARY SEWER UTILITY WORK. A CSU INSPECTOR MUST HAVE NOTICE SO WORK CAN BE INSPECTED, DOCUMENTED, AND A PROPER AS-BUILT MADE. WHEN A CONTRACTOR WORKS WEEKENDS, A CSU DESIGNATED HOLIDAY, OR BEYOND NORMAL CSU WORK HOURS, THE CONTRACTOR WILL PAY FOR THE INSPECTOR'S OVERTIME. FOR CSU WORK HOURS AND HOLIDAY INFORMATION, PLEASE CONTACT THE CITY OF BLOOMINGTON UTILITIES ENGINEERING DEPARTMENT AT (812)349-3660.

revisions:

ARCHITECTURE
 CIVIL ENGINEERING
 PLANNING
 BLOOMINGTON, INDIANA
 (812) 338-2800 (Fax)

BYNUM FANJO & ASSOCIATES, INC.
 628 North Walnut Street
 (812) 332-8030



PROPOSED
IU CREDIT UNION OPERATIONS CENTER
 EAST 3RD STREET
 BLOOMINGTON, INDIANA 47401

title: OVERALL SITE IMPROVEMENT PLAN

designed by: DJB
 drawn by: DJB
 checked by: JSF
 sheet no: C301
 project no: 401844

NOTE TO CONTRACTOR
 CONTRACTOR SHALL VERIFY ALL UTILITY LOCATIONS & DEPTHS AND NOTIFY ENGINEER OF ANY INCONGRUITIES IN LOCATION OR ELEVATION OR ANY CONFLICTS PRIOR TO & AFTER ANY EXCAVATION. NO PAYMENT SHALL BE MADE TO CONTRACTOR FOR UTILITY DESTRUCTION OR UNDERGROUND CHANGES REQUIRED DUE TO CONFLICTING ELEVATIONS.

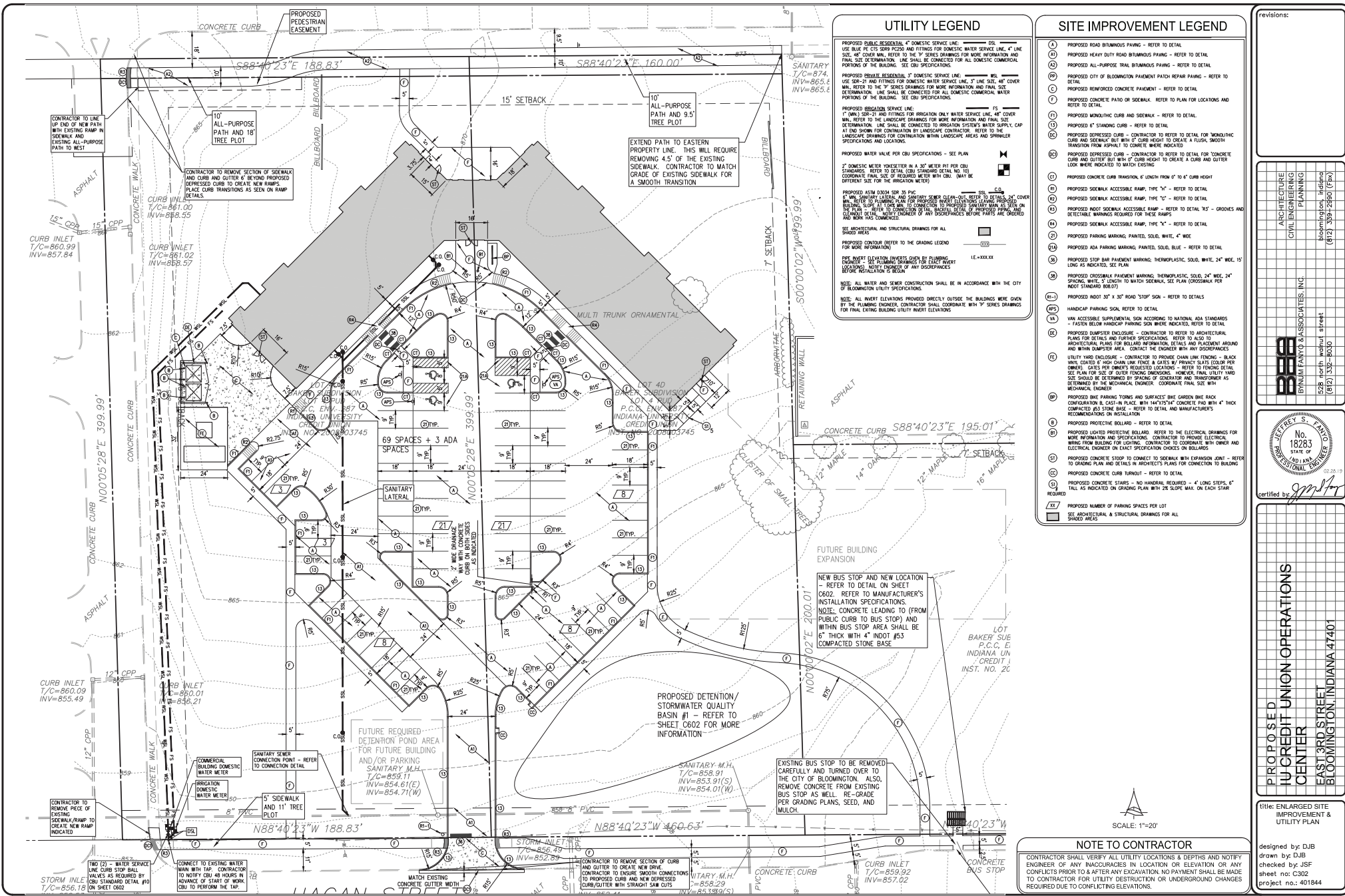

UTILITY LEGEND

PROPOSED PUBLIC RESIDENTIAL, 4" DOMESTIC SERVICE LINE, 4" DIA.
 USE BLUE PE CTS CURB RIZCO AND FITTINGS FOR DOMESTIC WATER SERVICE LINE, 4" LINE
 SIZE, 4' COVER MIN. REFER TO THE "P" SERIES DRAWINGS FOR MORE INFORMATION AND
 FINAL SIZE DETERMINATION. LINE SHALL BE CONNECTED FOR ALL DOMESTIC COMMERCIAL
 PORTIONS OF THE BUILDING. SEE CBU SPECIFICATIONS.

PROPOSED PRIVATE RESIDENTIAL, 1" DOMESTIC SERVICE LINE, 1" DIA.
 USE SAN-21 AND FITTINGS FOR DOMESTIC WATER SERVICE LINE, 3/4" LINE SIZE, 4" COVER
 MIN. REFER TO THE "P" SERIES DRAWINGS FOR MORE INFORMATION AND FINAL SIZE
 DETERMINATION. LINE SHALL BE CONNECTED FOR ALL DOMESTIC COMMERCIAL WATER
 PORTIONS OF THE BUILDING. SEE CBU SPECIFICATIONS.

PROPOSED IRRIGATION SERVICE LINE, 1" DIA.
 (1" UNFL. SAN-21 AND FITTINGS FOR IRRIGATION ONLY WATER SERVICE LINE, 4" COVER
 MIN. REFER TO THE "P" SERIES DRAWINGS FOR MORE INFORMATION AND FINAL SIZE
 DETERMINATION. LINE SHALL BE CONNECTED TO IRRIGATION SYSTEM'S WATER SUPPLY, CAP
 AT THE SOURCE FOR CONNECTION BY LANDSCAPE CONTRACTOR. REFER TO THE
 LANDSCAPE DRAWINGS FOR CONTINUATION WITHIN LANDSCAPE AREAS AND SPRINKLER
 SPECIFICATIONS AND LOCATIONS.

PROPOSED WATER VALVE PER CBU SPECIFICATIONS - SEE PLAN.

PROPOSED METER FOR WATER SERVICE LINE, 4" DIA. (MAY BE DIFFERENT SIZE FOR THE IRRIGATION NEEDS)

PROPOSED ATM DUCT 36" DIA. 36" DIA. 3" COVER MIN. REFER TO THE "P" SERIES DRAWINGS FOR MORE INFORMATION AND FINAL SIZE DETERMINATION. LINE SHALL BE CONNECTED TO IRRIGATION SYSTEM'S WATER SUPPLY, CAP AT THE SOURCE FOR CONNECTION BY LANDSCAPE CONTRACTOR. REFER TO THE LANDSCAPE DRAWINGS FOR CONTINUATION WITHIN LANDSCAPE AREAS AND SPRINKLER SPECIFICATIONS AND LOCATIONS.

SEE ARCHITECTURAL AND STRUCTURAL DRAWINGS FOR ALL
 REQUIRED SIZES.

PROPOSED CONDUIT (REFER TO THE GRADING LEGEND)
 1" DIA. 3" COVER MIN. REFER TO THE "P" SERIES DRAWINGS FOR MORE INFORMATION AND FINAL SIZE DETERMINATION.

SEE INVERT ELEVATIONS PROVIDED BY PLUMBING ENGINEER - SEE PLUMBING DRAWINGS FOR FLUET INVERT LOCATIONS AND ANY DISCREPANCIES BEFORE INSTALLATION IS BEGUN.

NOTE: ALL INVERT ELEVATIONS PROVIDED DIRECTLY OUTSIDE THE BUILDING WERE GIVEN BY THE PLUMBING ENGINEER. CONTRACTOR SHALL COORDINATE WITH "P" SERIES DRAWINGS FOR FINAL EXISTING BUILDING UTILITY INVERT ELEVATIONS.

SITE IMPROVEMENT LEGEND

- (1) PROPOSED ROAD BIOMIMICUS FINISH - REFER TO DETAIL
- (2) PROPOSED HEAVY DUTY ROAD BIOMIMICUS FINISH - REFER TO DETAIL
- (3) PROPOSED ALL-PURPOSE TRAIL BIOMIMICUS FINISH - REFER TO DETAIL
- (4) PROPOSED CITY OF BLOOMINGTON PAVEMENT PATCH REPAIR FINISH - REFER TO DETAIL
- (5) PROPOSED REINFORCED CONCRETE PAVEMENT - REFER TO DETAIL
- (6) PROPOSED CONCRETE PAVO OR SIDEWALK - REFER TO PLAN FOR LOCATIONS AND REFER TO DETAIL
- (7) PROPOSED MONOLITHIC CURB AND SIDEWALK - REFER TO DETAIL
- (8) PROPOSED 2" STANDING CURB - REFER TO DETAIL
- (9) PROPOSED DEPRESSED CURB - CONTRACTOR TO REFER TO DETAIL FOR MONOLITHIC CURB AND SIDEWALK BUT WITH CURB HEIGHT TO CREATE A FLUSH, SMOOTH TRANSITION FROM ASPHALT TO CONCRETE WHERE INDICATED
- (10) PROPOSED DEPRESSED CURB - CONTRACTOR TO REFER TO DETAIL FOR MONOLITHIC CURB AND SIDEWALK BUT WITH CURB HEIGHT TO CREATE A CURB AND GUTTER. LOOK WHERE INDICATED TO MATCH EXISTING
- (11) PROPOSED CONCRETE CURB TRANSITION, 6' LENGTH FROM 4" TO 6" CURB HEIGHT
- (12) PROPOSED SIDEWALK ACCESSIBLE RAMP, TYPE "A" - REFER TO DETAIL
- (13) PROPOSED SIDEWALK ACCESSIBLE RAMP, TYPE "B" - REFER TO DETAIL
- (14) PROPOSED SIDEWALK ACCESSIBLE RAMP - REFER TO DETAIL "B" - GROOVES AND DETECTABLE BURNINGS REQUIRED FOR THESE RAMPS
- (15) PROPOSED SIDEWALK ACCESSIBLE RAMP, TYPE "C" - REFER TO DETAIL
- (16) PROPOSED ASPHALT PARKING, PAINTED, SOLID, WHITE, 4" INCH
- (17) PROPOSED ASPHALT PARKING MARKING, PAINTED, SOLID, BLUE - REFER TO DETAIL
- (18) PROPOSED STOP BAR PAVEMENT MARKING, THERMOPLASTIC SOLID, WHITE, 24" WIDE, 15" LONG AS INDICATED, SEE PLAN
- (19) PROPOSED CROSSWALK PAVEMENT MARKING, THERMOPLASTIC SOLID, 24" WIDE, 24" SPACING, WHITE, 5" LENGTH TO MATCH SIDEWALK, SEE PLAN (CROSSWALK PER MUTI STANDARD 806.7)
- (20) PROPOSED ADOT 30' x 30' ROAD "STOP" SIGN - REFER TO DETAIL
- (21) HANDICAP PARKING SIGN, REFER TO DETAIL
- (22) VAN ACCESSIBLE SUPPLEMENTAL SIGN ACCORDING TO NATIONAL ADA STANDARDS - FASTEN BELOW HANDICAP PARKING SIGN WHERE INDICATED, REFER TO DETAIL
- (23) PROPOSED BARRIER ENCLOSURE - CONTRACTOR TO REFER TO ARCHITECTURAL PLANS FOR DETAILS AND FURTHER SPECIFICATIONS. REFER TO ALSO TO ARCHITECTURAL PLANS FOR BARRIER INFORMATION, DETAILS AND ADJACENT HANDING AND WITHIN DAMPER AREA. CONTACT THE ENGINEER WITH ANY DISCREPANCIES
- (24) UTILITY YARD ENCLOSURE - CONTRACTOR TO PROVIDE CHAIN LINK FENCING - BLACK VINYL COATED 6" HIGH CHAIN LINK FENCE & GATES BY PRIVATE STATE COLOR PER OWNER. GATES PER OWNER'S REQUESTED LOCATIONS - REFER TO FENCING DETAIL. SET PLAN FOR SIZE OF OUTER FENCING ENCLOSURE. HOWEVER, FINAL UTILITY YARD SIZE SHOULD BE DETERMINED BY SPACING OF GENERATOR AND TRANSFORMER AS DETERMINED BY THE MECHANICAL ENGINEER. COORDINATE FINAL SIZE WITH MECHANICAL ENGINEER
- (25) PROPOSED BARRIER TORSION AND SURVEY THE GARDEN BUT BACK CONFIGURATION 8' CAST-IN PLACE WITH 144"x75"x4" CONCRETE PAVO WITH 4" THICK COMPACTED #53 STONE BASE - REFER TO DETAIL AND MANUFACTURER'S RECOMMENDATIONS ON INSTALLATION
- (26) PROPOSED PROTECTIVE BOLLARD - REFER TO DETAIL
- (27) PROPOSED LIGHTED PROTECTIVE BOLLARD - REFER TO THE ELECTRICAL DRAWINGS FOR MORE INFORMATION AND SPECIFICATIONS. CONTRACTOR TO PROVIDE ELECTRICAL WIRING FOR BOLLARD LIGHTING. CONTRACTOR TO COORDINATE WITH OWNER AND ELECTRICAL ENGINEER ON EXACT SPECIFICATION CHOICES ON BOLLARDS
- (28) PROPOSED CONCRETE STOOD TO CONNECT TO SIDEWALK WITH EXPANSION JOINT - REFER TO GRADING PLAN AND DETAILS IN ARCHITECT'S PLANS FOR CONNECTION TO BUILDING
- (29) PROPOSED CONCRETE CURB TURNOUT - REFER TO DETAIL
- (30) PROPOSED CONCRETE STAIRING NO HANDRAIL REQUIRED - 4" LONG STEPS, 6" HIGH AS INDICATED ON GRADING PLAN WITH 25% SLOPE MAX. ON EACH STEP AS REQUIRED
- (31) PROPOSED NUMBER OF PARKING SPACES PER LOT
- (32) ARCHITECTURAL & STRUCTURAL DRAWINGS FOR ALL SHaded AREAS

NOTE TO CONTRACTOR

CONTRACTOR SHALL VERIFY ALL UTILITY LOCATIONS & DEPTHS AND NOTIFY ENGINEER OF ANY INACCURACIES IN LOCATION OR ELEVATION OR ANY CONFLICTS PRIOR TO & AFTER ANY EXCAVATION. NO PAYMENT SHALL BE MADE TO CONTRACTOR FOR UTILITY DESTRUCTION OR UNDERGROUND CHANGES REQUIRED DUE TO CONFLICTING ELEVATIONS.

revisions:

		ARCHITECTURE
		CIVIL ENGINEERING
		PLANNING
		INTEGRATED

BLM BYNUM FANVO & ASSOCIATES, INC.
 Bloomington, Indiana
 (812) 338-2900 (Fax)

No. 18283 STATE OF INDIANA PROFESSIONAL ENGINEER

certified by *[Signature]*

PROPOSED IU CREDIT UNION OPERATIONS CENTER
 EAST 13RD STREET
 BLOOMINGTON, INDIANA 47401

title: ENLARGED SITE IMPROVEMENT & UTILITY PLAN

designed by: DJB
 drawn by: DJB
 checked by: JSF
 sheet no: C302
 project no: 401844



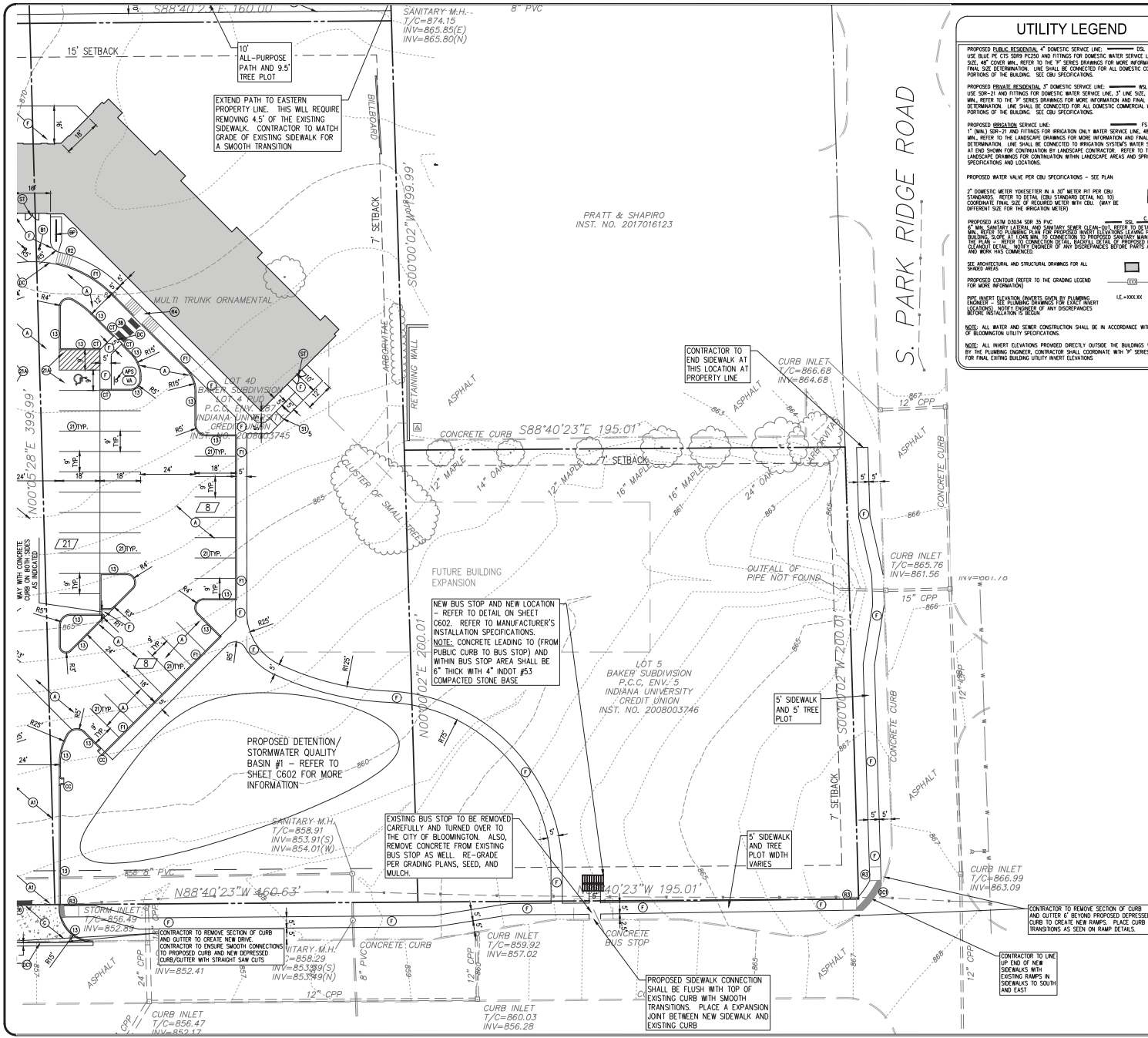

UTILITY LEGEND

PROPOSED PUBLIC RESIDENTIAL 4" DOMESTIC SERVICE LINE - SEE PLAN	DS
USE BLUE PE CTS SDR35 PCSD AND FITTINGS FOR DOMESTIC WATER SERVICE LINE. 4" LINE SIZE. 40' COVER MIN. REFER TO THE "D" SERIES DRAWINGS FOR MORE INFORMATION AND FINAL SIZE DETERMINATION. LINE SHALL BE CONNECTED FOR ALL DOMESTIC COMMERCIAL PORTIONS OF THE BUILDING. SEE CSD SPECIFICATIONS.	
PROPOSED PRIVATE RESIDENTIAL 1" DOMESTIC SERVICE LINE - SEE PLAN	WS
USE SDR-21 AND FITTINGS FOR DOMESTIC WATER SERVICE LINE. 2" LINE SIZE. 48" COVER MIN. REFER TO THE "D" SERIES DRAWINGS FOR MORE INFORMATION AND FINAL SIZE DETERMINATION. LINE SHALL BE CONNECTED FOR ALL DOMESTIC COMMERCIAL WATER PORTIONS OF THE BUILDING. SEE CSD SPECIFICATIONS.	
PROPOSED IRRIGATION SERVICE LINE - SEE PLAN	IS
1" (1/4") SDR-21 AND FITTINGS FOR IRRIGATION ONLY WATER SERVICE LINE. 48" COVER MIN. REFER TO THE LANDSCAPE DRAWINGS FOR MORE INFORMATION AND FINAL SIZE DETERMINATION. LINE SHALL BE CONNECTED TO IRRIGATION SYSTEM'S WATER SUPPLY. CAP AT THE SHOWN FOR CONNECTION BY LANDSCAPE CONTRACTOR. REFER TO THE LANDSCAPE DRAWINGS FOR CONNECTION WITHIN LANDSCAPE AREAS AND SPRINKLER SPECIFICATIONS AND LOCATIONS.	
PROPOSED WATER VALVE PER CSD SPECIFICATIONS - SEE PLAN	WV
2" DOMESTIC METER YOKER/ETER IN A 30" METER PIT PER CSD STANDARDS. REFER TO DETAIL (CSD STANDARDS DETAIL NO. 10) COORDINATE FINAL SIZE OF REQUIRED METER WITH CSD. (MAY BE DIFFERENT SIZE FOR THE IRRIGATION METERS)	Y
PROPOSED ASYM 63M SDR 35 PVC 6" W.R. SANITARY LATERAL AND SANITARY SEWER CLEAN-OUT REFER TO DETAILS A-D, COVER SHALL BE 12" TO 18" REFER TO THE "D" SERIES DRAWINGS FOR MORE INFORMATION AND FINAL SIZE DETERMINATION. REFER TO CONNECTION DETAIL (BASIN) DETAIL OF PROPOSED PUMP AND LATEST DETAIL. NOTE: NUMBER OF ANY DISCREPANCIES BEFORE INSTALLATION IS BEGUN	SS
PROPOSED CONDUIT REFER TO THE GRADING LEGEND FOR MORE INFORMATION	C
PROPOSED ARCHITECTURAL AND STRUCTURAL DRAWINGS FOR ALL REFER TO DETAIL	AS
PROPOSED CONTOUR REFER TO THE GRADING LEGEND FOR MORE INFORMATION	C
POST ASBEST ELEVATION INVERTS GIVEN BY PLUMBING ENGINEER. SET PLUMBING TRIMMING FOR EXACT INVERT	LE=XXXX
NOTE: ALL INVERT ELEVATIONS PROVIDED DIRECTLY OUTSIDE THE BUILDING WERE GIVEN BY THE PLUMBING ENGINEER. CONTRACTOR SHALL COORDINATE WITH "D" SERIES DRAWINGS FOR FINAL EXISTING BUILDING UTILITY INVERT ELEVATIONS	

SITE IMPROVEMENT LEGEND

(A)	PROPOSED ROAD BITUMINOUS PAVING - REFER TO DETAIL
(B)	PROPOSED HEAVY DUTY ROAD BITUMINOUS PAVING - REFER TO DETAIL
(C)	PROPOSED ALL-PURPOSE TRAIL BITUMINOUS PAVING - REFER TO DETAIL
(D)	PROPOSED CITY OF BLOOMINGTON PAVEMENT PATCH REPAIR PAVING - REFER TO DETAIL
(E)	PROPOSED REINFORCED CONCRETE PAVEMENT - REFER TO DETAIL
(F)	PROPOSED CONCRETE PATIO OR SIDEWALK - REFER TO PLAN FOR LOCATIONS AND REFER TO DETAIL
(G)	PROPOSED MONOLITHIC CURB AND SIDEWALK - REFER TO DETAIL
(H)	PROPOSED 6" STANDING CURB - REFER TO DETAIL
(I)	PROPOSED DEPRESSIONED CURB - CONTRACTOR TO REFER TO DETAIL FOR MONOLITHIC CURB AND SIDEWALK BUT WITH CURB HEIGHT TO CREATE A FLUSH, SMOOTH TRANSITION FROM ASPHALT TO CONCRETE WHERE INDICATED
(J)	PROPOSED DEPRESSIONED CURB - CONTRACTOR TO REFER TO DETAIL FOR CONCRETE CURB AND GUTTER BUT WITH CURB HEIGHT TO CREATE A CURB AND GUTTER LOOK WHERE INDICATED TO MATCH EXISTING
(K)	PROPOSED CONCRETE CURB TRANSITION, 4' LENGTH FROM 6" TO 12" CURB HEIGHT
(L)	PROPOSED SIDEWALK ACCESSIBLE RAMP, TYPE "A" - REFER TO DETAIL
(M)	PROPOSED SIDEWALK ACCESSIBLE RAMP, TYPE "B" - REFER TO DETAIL
(N)	PROPOSED INDOT SIDEWALK ACCESSIBLE RAMP - REFER TO DETAIL "N1" - GROOVES AND DETECTABLE MARKINGS REQUIRED FOR THESE RAMPS
(O)	PROPOSED SIDEWALK ACCESSIBLE RAMP, TYPE "X" - REFER TO DETAIL
(P)	PROPOSED PARKING MARKING, PAINTED, SOLID, WHITE, 4" WIDE
(Q)	PROPOSED ADA PARKING MARKING, PAINTED, SOLID, BLUE - REFER TO DETAIL
(R)	PROPOSED STOP BAR PAVEMENT MARKING, THERMOPLASTIC, SOLID, WHITE, 24" WIDE, 15' LONG AS INDICATED, SEE PLAN
(S)	PROPOSED CROSSWALK PAVEMENT MARKING, THERMOPLASTIC, SOLID, 24" WIDE, 24" SPACING, WHITE, 5' LENGTH TO MATCH SIDEWALK, SEE PLAN (CROSSWALK PER INDOT STANDARD B007)
(T)	PROPOSED INDOT 30' x 30' ROAD STOP SIGN - REFER TO DETAILS
(U)	PROPOSED HANDICAP PARKING SIGN, REFER TO DETAIL
(V)	VAN ACCESSIBLE SUPPLEMENTAL SIGN ACCORDING TO NATIONAL ADA STANDARDS - FASTEN BELOW HANDICAP PARKING SIGN WHERE INDICATED, REFER TO DETAIL
(W)	PROPOSED DUMPSTER ENCLOSURE - CONTRACTOR TO REFER TO ARCHITECTURAL PLANS FOR DETAILS AND FURNISH SPECIFICATIONS. REFER TO ALSO TO ARCHITECTURAL PLANS FOR BOLLARD INFORMATION, DETAILS AND PLACEMENT AROUND AND WITHIN DUMPSTER AREA. CONTACT THE ENGINEER WITH ANY DISCREPANCIES
(X)	UTILITY YARD ENCLOSURE - CONTRACTOR TO PROVIDE CHAIN LINK FENCING - BLACK WITH COATED 4" HIGH CHAIN LINK FENCE IN GATES BY PRACTICE SLATS (COLOR PER OWNER). GATES PER OWNER'S REQUESTED LOCATIONS - REFER TO FINISHING DETAIL. SEE PLAN FOR SIZE OF OUTER FENCING DIMENSIONS. HOWEVER, FINAL UTILITY YARD SIZE SHALL BE DETERMINED BY SPACING OF OWNER AND TRANSFORMER AS DETERMINED BY THE MECHANICAL ENGINEER. COORDINATE FINAL SIZE WITH MECHANICAL ENGINEER
(Y)	PROPOSED ONE PARKING STOPS AND SURFACES ONE CARBON BITE BACK CONFIGURATION & CAST-IN PLACE, WITH 14"x24"x4" CONCRETE PAD WITH 4" THICK COMPACTED #53 STONE BASE - REFER TO DETAIL AND MANUFACTURER'S RECOMMENDATIONS ON INSTALLATION
(Z)	PROPOSED PROTECTIVE BOLLARD - REFER TO DETAIL
(AA)	PROPOSED LIGHTED PROTECTIVE BOLLARD - REFER TO THE ELECTRICAL DRAWINGS FOR MORE INFORMATION AND SPECIFICATIONS. CONTRACTOR TO PROVIDE ELECTRICAL BRING FROM BUILDING FOR LIGHTING. CONTRACTOR TO COORDINATE WITH OWNER AND ELECTRICAL ENGINEER ON EACH SPECIFICATION CHOICES ON BOLLARDS
(AB)	PROPOSED CONCRETE STOP - REFER TO DETAIL
(AC)	PROPOSED CONCRETE STOP TO CONNECT TO SIDEWALK WITH EXPANSION JOINT - REFER TO GRADING PLAN AND DETAILS IN ARCHITECT'S PLANS FOR CONNECTION TO BUILDING
(AD)	PROPOSED CONCRETE CURB TURNOUT - REFER TO DETAIL
(AE)	PROPOSED CONCRETE STAIRS - NO HORIZONTAL REINFORCING - 4" LONG STEPS, 4" TALL AS INDICATED ON GRADING PLAN WITH 2% SLOPE MAX. ON EACH STAR
(AF)	PROPOSED NUMBER OF PARKING SPACES PER LOT
(AG)	SEE ARCHITECTURAL & STRUCTURAL DRAWINGS FOR ALL SHADED AREAS

NOTE TO CONTRACTOR

CONTRACTOR SHALL VERIFY ALL UTILITY LOCATIONS & DEPTHS AND NOTIFY ENGINEER OF ANY DISCREPANCIES IN LOCATION OR ELEVATION OR ANY CONFLICTS PRIOR TO & AFTER ANY EXCAVATION. NO PAYMENT SHALL BE MADE TO CONTRACTOR FOR UTILITY DESTRUCTION OR UNDERGROUND CHANGES REQUIRED DUE TO CONFLICTING ELEVATIONS.

revisions:

	ARCHITECTURE
	CIVIL ENGINEERING
	PLANNING
	MECHANICAL
	ELECTRICAL
	LANDSCAPE ARCHITECTURE
	TRAFFIC ENGINEERING
	UTILITY ENGINEERING
	WATER RESOURCES ENGINEERING
	CONSTRUCTION
	ENVIRONMENTAL
	GEOTECHNICAL
	INSULATION
	PAVEMENT
	PLUMBING
	ROOFING
	STRUCTURAL
	VEGETATION
	WATER SUPPLY

BYNUM FAY & ASSOCIATES, INC.
 528 North Walnut Street
 Bloomington, Indiana 47404
 (812) 338-2500 (Fax)

LETITIA S. FINN
 No. 18283
 STATE OF INDIANA
 PROFESSIONAL ENGINEER
 02-02-19

certified by *[Signature]*

PROPOSED
 IU CREDIT UNION OPERATIONS
 CENTER
 EAST 13RD STREET
 BLOOMINGTON, INDIANA 47401

title: ENLARGED SITE IMPROVEMENT AND UTILITY PLAN

designed by: DJB
 drawn by: DJB
 checked by: JSF
 sheet no: C303
 project no: 401844

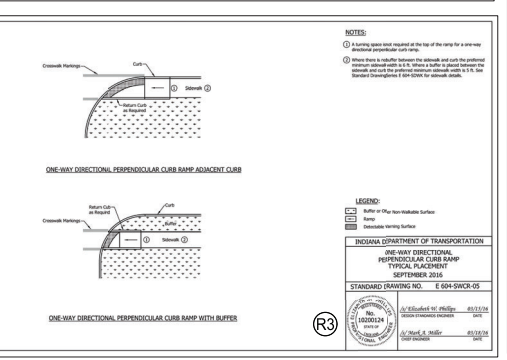
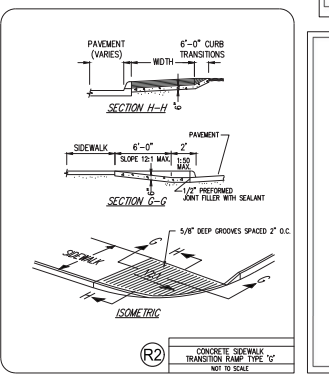
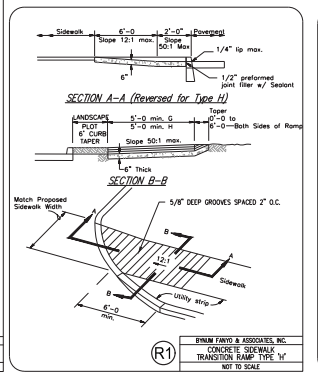
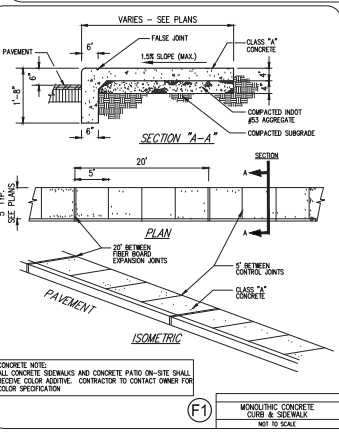
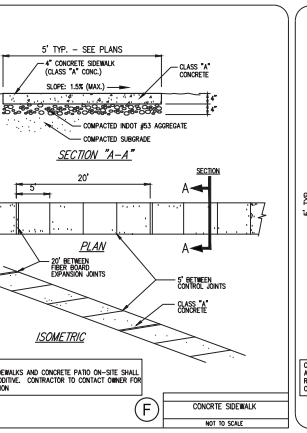
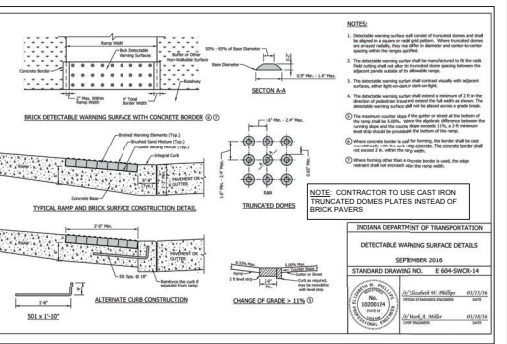
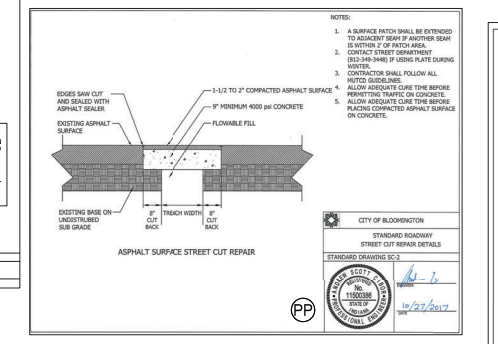
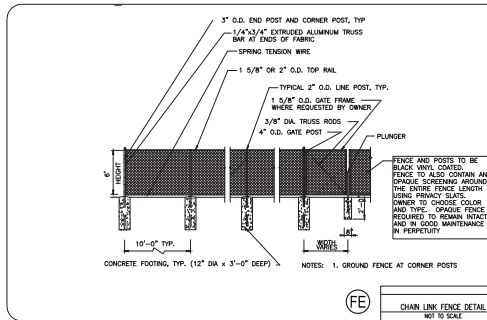
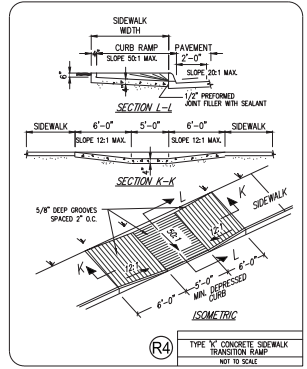
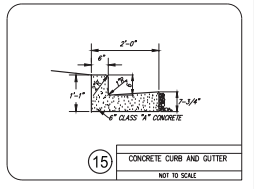
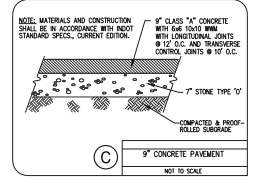
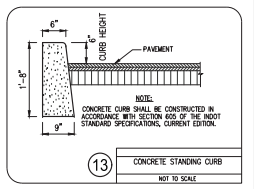
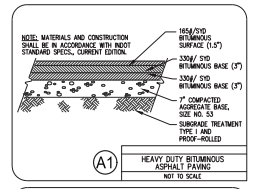
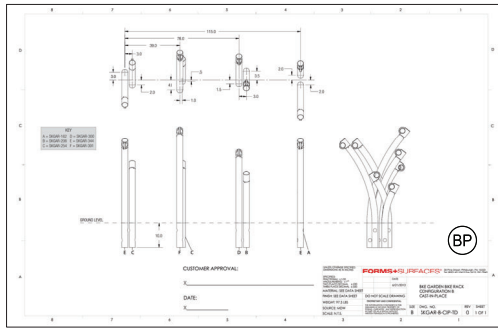
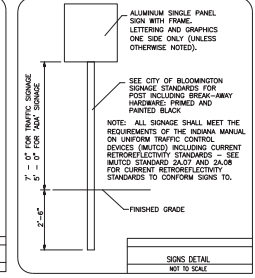
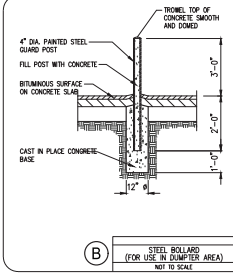
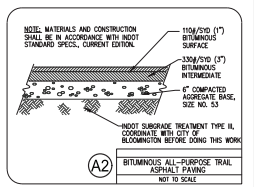
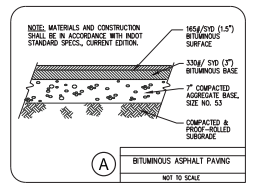
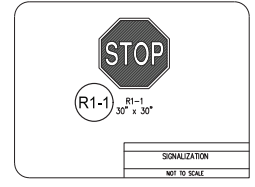
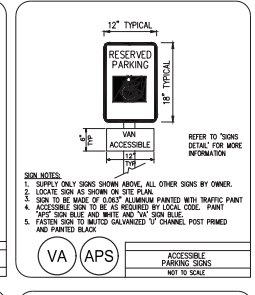
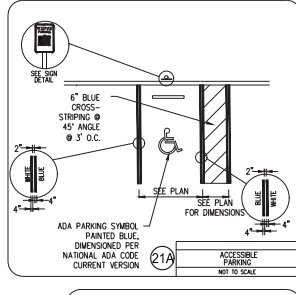
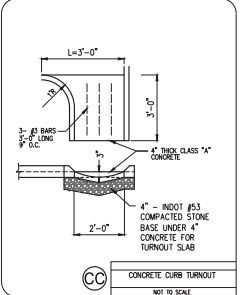

revisions:

ARCHITECTURE	PLANNING
CIVIL ENGINEERING	

BYNUM FANTY & ASSOCIATES, INC.
Bloomington, Indiana
62B North Walnut Street
(812) 338-2500 (Fax)

LEITCH, S. FANTY
No. 18283
STATE OF INDIANA
PROFESSIONAL ENGINEER
certified by [Signature]

PROPOSED
IU CREDIT UNION OPERATIONS
CENTER
EAST 13RD STREET
BLOOMINGTON, INDIANA 47401

title: SITE IMPROVEMENT
PLAN DETAILS

designed by: DJB
drawn by: DJB
checked by: JSF
sheet no: C001
project no: 401844



Aerial View from North



Employee Entry



Outdoor Patio



View from West



View from Southwest



North Elevation – Third Street Side



South Elevation – Main Entry facing Hagan

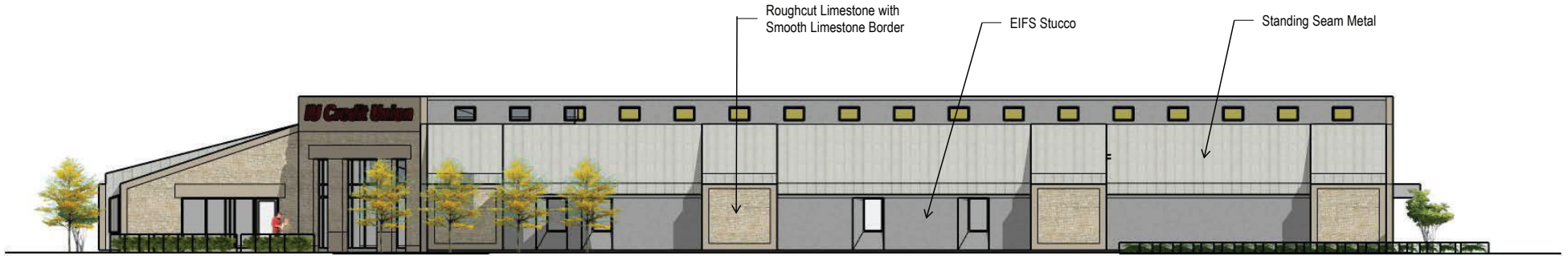

West Elevation (toward Funeral Home Neighbor), East Elevation similar

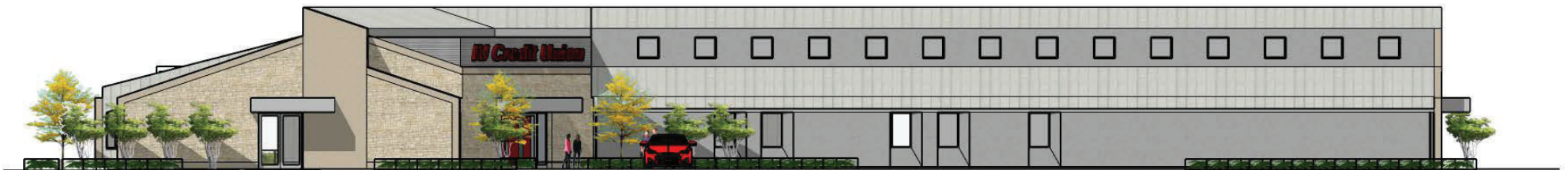

South Elevation (toward Hagan)





Floor Plan
 1/16"=1'-0"



ROWLAND DESIGN
 ARCHITECTURE INTERIORS GRAPHICS

702 North Capitol Avenue
 Indianapolis, Indiana 46204

p 317 636-3980
 f 317 263-2073

www.rowlanddesign.com

IU Credit Union
 Operations Building

Date: 1 March 2019 Issue: City Submittal

Drawn By:
 Scale: as shown
 Project Number: 18.091



**BLOOMINGTON PLAN COMMISSION
STAFF REPORT
Location: 2917 S. McIntire Drive**

**CASE #: PUD-06-19
DATE: March 18, 2019**

PETITIONER: Progress Construction & Development, INC
2917 S. McIntire Drive, Bloomington, IN

CONSULTANT: Bynum Fanyo & Associates, INC
528 North Walnut Street, Bloomington, IN

REQUEST: Final Plan approval for a new building trade shop in a Planned Unit Development.

BACKGROUND:

Area: 2.8 acres
Current Zoning: PUD
Comprehensive Plan Designation: Employment Center
Existing Land Use: Undeveloped
Proposed Land Use: Contractors Office
Surrounding Uses: North – Medical Office
 West – Medical Office
 East – Vacant (Indiana Health Sciences PUD)
 South – Vacant

SUMMARY: The property is located just east of S. McIntire Drive and is separated from McIntire Drive by two other properties. The property is currently undeveloped and is within a Planned Unit Development (PUD) that was approved in 1986 (ML/PCD-25-86). The property is surrounded by a mix of medical offices and vacant land. There are medical offices to the north and west, undeveloped land the south, and land to the east is within a separate PUD approved as Southern Indiana Medical Park Phase 2.

The property was heavily graded and disturbed with the initial layout of the development. All of the existing trees are less than 10 years old and there are no natural creeks or riparian buffers on the site. There is a storm water detention pond on the lot to the south.

The petitioner proposes to construct a new 10,000 square foot, single story commercial building trade shop on the site with twenty (20) proposed parking spaces. The proposed entrance to the building is on the northwest corner of the building and the building has five (5) delivery bays along the eastern elevation. A sidewalk connection from this site to the adjacent sidewalk system will be installed with the new construction. New landscaping will also be installed throughout the site to meet UDO requirements.

SITE PLAN ISSUES: *New building construction on a lot requires that the lot come into full compliance with the UDO (20.08.060(a)). Where regulations are not addressed in the PUD, the Department has used the Industrial General (IG) zoning standards to review this site plan.*

Development Standard: The building will be one-story and is 18.8' tall. The front faces west and will be finished with EIFS and steel. The building will not be visible from the public street.

Architecture/Design: Proposed materials include Exterior Insulation Finish System (EIFS), 26 Gage Painted Steel Siding, and glass windows. The PUD did not have specific building architecture requirements other than those sides of a building facing a road must have a pleasing design. The Department believes that the proposed architecture is appropriate for a building trade shop.

Vehicular Access: Access to the site will come from an existing drive cut and drive on S. McIntire Drive to the west. The drive is currently used as entrances to two adjacent properties to the west and southwest of the proposed building. There is currently auxiliary parking on the north side of the drive which will be removed when the property is developed.

Pedestrian Facilities: There is an existing sidewalk along McIntire Drive frontage and the petitioner has included a sidewalk connection from this sidewalk to the north end of the proposed parking area and leading to the front entrance of the building. There are no other internal sidewalks to connect to.

Vehicular Parking: Twenty (20) vehicular spaces are proposed. The parking maximum for a "building trade shop" is one (1) space per employee on the largest shift. According to their submitted materials, they will have 35 employees on the largest shift. The proposed number of spaces does not exceed the parking maximum.

Bicycle Parking: The site is required to have a minimum of four (4) bicycle parking spaces. There are proposed racks on the northwest corner of the building which is suitable for three (3) bicycle spaces. These should be expanded to meet code requirements of four (4) bicycle parking spaces.

Environmental: The petitioner has proposed to create a 0.81 acre Tree preservation/conservancy easement for all portions of the site that will not be disturbed. This is not a requirement but is something the petitioner is voluntarily committing to.

Lighting: A lighting and photometric plan will have to be submitted which shows the site meets the UDO requirements for maximum light trespass and fixture types before a building permit will be granted. No deviations from the lighting code are allowed.

20.04.090 PUD Final Plan- The UDO does not list specific findings criteria for PUD Final Plans, but does list what items shall be considered by the Plan Commission in a review:

(A) The written statement and supportive material submitted by the petitioner;

Recommended Finding: The petitioner has provided all required materials.

(B) The PUD District Ordinance;

Recommended Finding: The proposed petition meets the original PUD District Ordinance guidance and the Department has used the current Industrial General development standards for any items that were not addressed in the district ordinance.

(C) The Preliminary Plan;

Recommended Finding: The approved preliminary plan showed this lot as a partially developed commercial lot with parking and an allowable amount of impervious surface coverage. A .81 acre tree preservation/conservancy easement will help ensure that the lot will not go over the impervious surface maximum.

(D) The Final Plan;

Recommended Finding: The petition is the Final Plan for the site.

(E) Any commitments or conditions of approval attendant to prior approvals;

Recommended Finding: There were no previous commitments or conditions that were imposed on the final plan approval.

(F) Any applicable section of the Unified Development Ordinance;

Recommended Finding: The petition is subject to the current standards of the UDO for architecture, height, and environmental standards as well as any other current standards in the UDO that were lacking in the original PUD.

(G) Additional information as may be required by the Plan Commission to evaluate the application.

Recommended Finding: No additional information has so far been requested by the Plan Commission for this site.

ENVIRONMENTAL COMMISSION RECOMMENDATIONS:

1.) Ensure no fugitive hazardous materials are released by at least constructing a soil berm at the downslope side of soil disturbance, planting a thick cover of vegetation that could adsorb hydrocarbons planted at the downslope edge of the disturbance limits but upslope of the berm, additional monitoring for releases/spills, and developing a culture of environmental protection that permeates the work place.

STAFF RESPONSE: This will be reviewed prior to issuance of a grading permit.

2.) The Petitioner should work with staff to revise the Landscape Plan to at least meet the minimum standards of the UDO.

STAFF RESPONSE: The petitioner will need to submit UDO compliant landscape plan prior to issuance of a grading permit.

3.) The Petitioner should incorporate best practices for green building.

STAFF RESPONSE: Although not required, the Department encourages the petitioner to incorporate as many green building features as possible.

RECOMMENDATION: Staff recommends approval of this petition with the following condition:

1. All portions of site not disturbed to be placed in conservation easement.
2. A grading permit is required prior to any site disturbance.

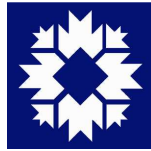

City of Bloomington
Bloomington Environmental Commission

MEMORANDUM

Date: March 18, 2019

To: Bloomington Plan Commission

From: Bloomington Environmental Commission

Subject: PUD-06-19: R&B Construction
2917 S. McIntyre Dr.
Lot 6 Southern Indiana Medical Park

The purpose of this memo is to convey the environmental concerns and recommendations provided by the City of Bloomington Environmental Commission (EC) with the hope that action will be taken to enhance the project's environment-enriching attributes. The EC reviewed the petition and offers the following comments and requests for your consideration.

1.) HAZARDOUS MATERIALS PROTECTIONS

The storage and maintenance of construction equipment at this site is likely to result in increased potential for hazardous materials making their way to the stream downslope. For this reason, the EC believes this tucked-away site, sloping to a tributary of the West Fork of Clear Creek, is a poor choice for this type of use; however, it is an allowed use per its PUD. For this reason, the EC believes that precautions should be taken that exceed those of other uses on similar sites.

The remedial actions listed by the Petitioner in the Storm Water Pollution Prevention Plan are not sufficient for day to day activities after construction is complete and business begins. At the end of a busy day, some of these actions may be overlooked. Examples include: seal drains and inlets with plastic and or tape and collect excess cleaning solvents; care should be taken to minimize overspray of paint; equipment washing shall be executed in a location which does not cause wastewater to drain directly to storm sewers or ditches; and using 3 ft. by 3 ft. by 6 inch spill pans during fueling of gasoline, diesel fuel, and kerosene.

The list of possible pollutants provided by the Petitioner include the following.

- Cleaning solvents
- Wastewater from washing construction equipment
- Hydraulic oils and fluids
- Gasoline
- Diesel fuel
- Kerosene

Antifreeze coolant asphalt
 Concrete
 Curing compounds
 Solid waste (trash)
 Soil erosion
 Liquid or granular fertilizers

The EC recommends that a soil berm be constructed, thick vegetation that could adsorb hydrocarbons be planted at the downslope edge of the disturbance limits but upslope of the berm, additional monitoring for releases/spills, and development of a strong culture of environmental protection permeate the work place.

2.) LANDSCAPE PLAN

The Landscape Plan needs a few small changes before it meets the Unified Development Ordinance (UDO) regulations, and can be approved. The Petitioner must have an approved plan in place prior to being granted a Grading Permit. The EC recommends the site be designed with plantings that benefit local pollinating insects and birds, reduce the heat island effect, and slow and cleanse rainwater. Using native plants provides food and habitat for birds, butterflies and other beneficial insects, promoting biodiversity in the city. Native plants do not require chemical fertilizers or pesticides and are water efficient once established.

3.) GREEN/ENVIRONMENT-ENHANCING BUILDING PRACTICES

The EC understands that this building is office, garage, and storage space for a construction company. That is all the more reason to build it using green building practices. The EC recommends incorporating all of the green building practices available, including some specific ones listed below.

a. Reduce the Heat Island Effect The roof material should have a minimum initial Solar Reflective Index (SRI) of 0.65, and an aged index of 0.55. *SRI* is a value that incorporates both solar reflectance and emittance in a single value to represent a material's temperature in the sun. *SRI* quantifies how hot a surface would get relative to standard black and standard white surfaces. It is calculated using equations based on previously measured values of solar reflectance and emittance as laid out in the American Society for Testing and Materials Standard E 1980. It is expressed as a fraction (0.0 to 1.0) or percentage (0% to 100%). This can be achieved by choosing a membrane that is not only white, but also embedded with reflective material.

b. Solar energy generation Install solar photovoltaic cells to reduce the use of greenhouse-gas emitting pollutants, which harm the environment and contribute to common health problems such as asthma. Using solar energy helps protect the user against volatile utility rates, adds value to the property, and supports the local economy. This building is ideal for photovoltaic (PV) solar panels because it has a very low pitch roof. Solar power is now competitive with coal, especially considering the full-cost accounting price.

c. Building envelope The EC recommends that the building envelope be constructed with higher insulation values than the minimums in the Building Code. The HVAC system also should exceed standards for this type of business.

d. Recycling The EC recommends that space be allocated for recyclable materials collection, which will reduce the facility's carbon footprint and promote healthy indoor and outdoor environments.

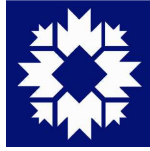

City of Bloomington Bloomington Environmental Commission

Recycling has become an important norm that has many benefits in energy and resource conservation. Recycling is an elementary environmental practice, given that the City of Bloomington has been promoting it since the early seventies; thus, an important contributor to Bloomington's environmental quality and sustainability and is expected in a 21st-century structure.

EC RECOMMENDATIONS:

- 1.) Ensure no fugitive hazardous materials are released by at least constructing a soil berm at the downslope side of soil disturbance, planting a thick cover of vegetation that could adsorb hydro carbons planted at the downslope edge of the disturbance limits but upslope of the berm, additional monitoring for releases/spills, and developing a culture of environmental protection that permeates the work place.
- 2.) The Petitioner should work with staff to revise the Landscape Plan to at least meet the minimum standards of the UDO.
- 3.) The Petitioner should incorporate best practices for green building.

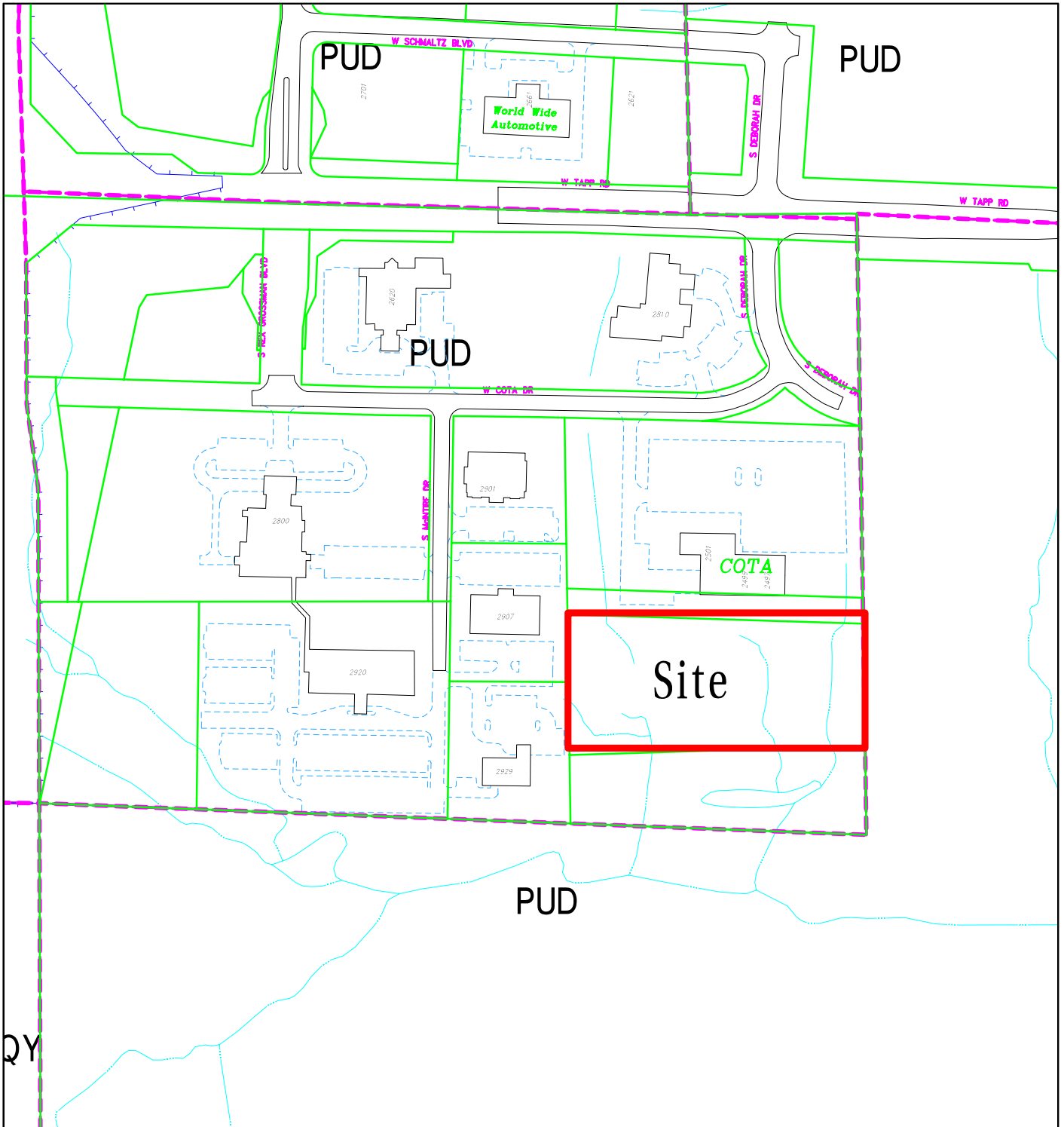

PUD-06-19 Southern Indiana Medical Park

2917 S. McIntire Drive

Plan Commission

Site Location, Zoning, Parcels

By: greulice

1 Feb 19

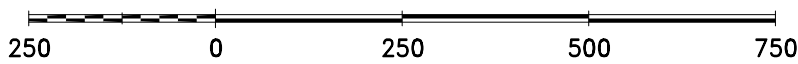

City of Bloomington
Planning & Transportation

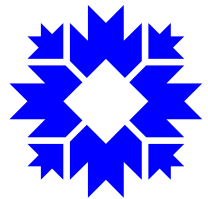

Scale: 1" = 250'

For reference only; map information NOT warranted.

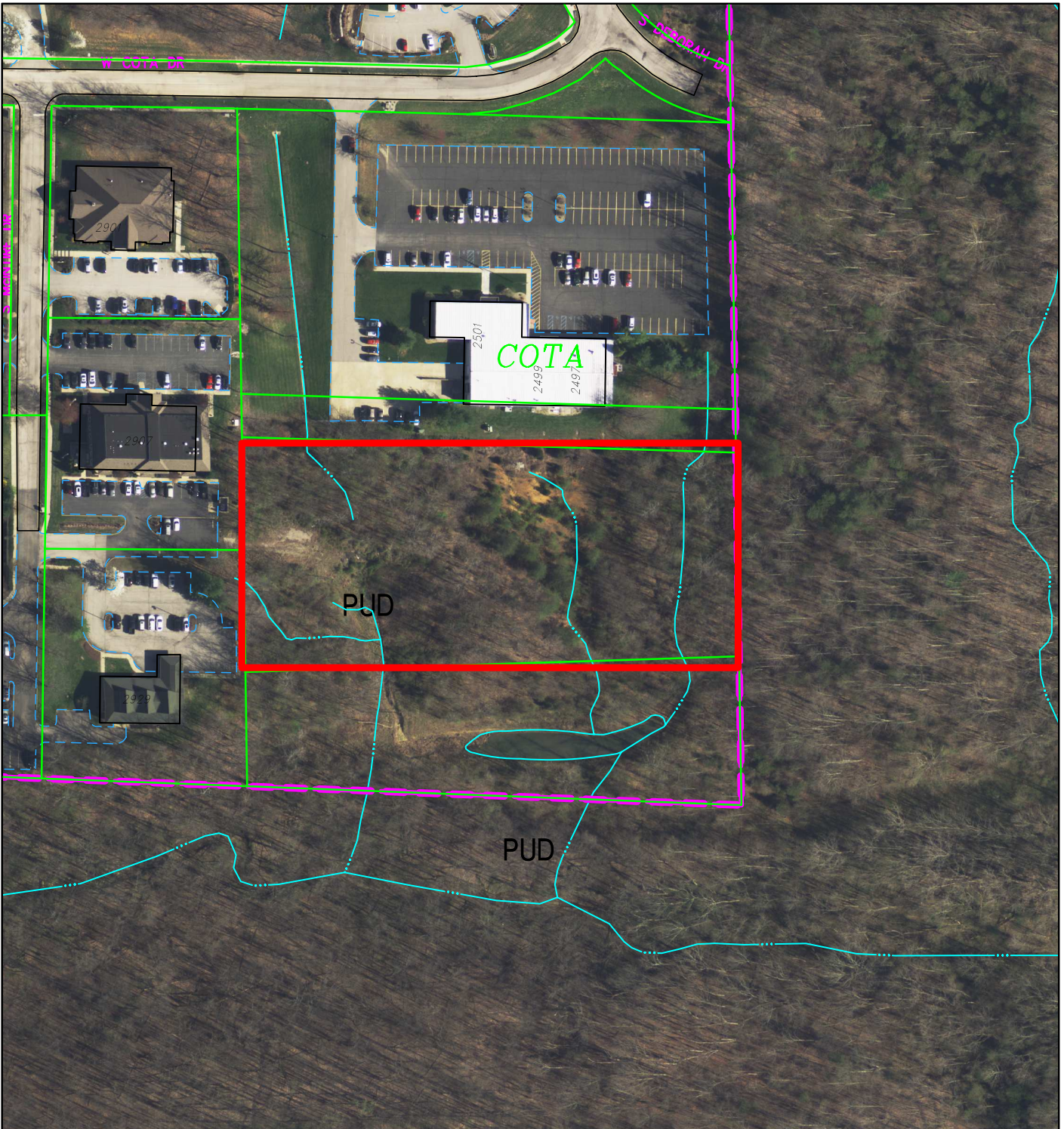

PUD-06-19 Southern Indiana Medical Park

2917 S. McIntire Drive

Plan Commission

2016 Aerial Photograph

By: greulice

1 Feb 19

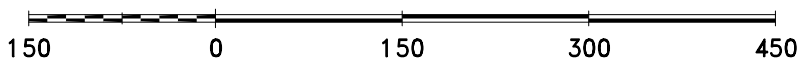

For reference only; map information NOT warranted.

City of Bloomington
Planning & Transportation

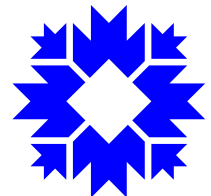

Scale: 1" = 150'



PROPOSED: PROGRESS CONSTRUCTION & DEVELOPMENT, INC. - SIMP

2917 S. MCINTIRE DRIVE
BLOOMINGTON, IN 47403

UTILITY CONTACT INFORMATION	
GAS	SCENE AND WATER
VECTREN	CITY OF BLOOMINGTON UTILITIES
295 S. MASON ST.	DAVE ENERGY
BLOOMINGTON, IN 47403	169 N. DORTCHMOUTH ROAD
6300 ANDERSON (317)335-4000	BLOOMINGTON, IN 47404
	600 E. MILLER DR.
	BLOOMINGTON, IN 47404
	400 W. WASHINGTON (317)337-5011
	400 W. WASHINGTON (317)337-5011
TELEPHONE	CABLE TELEVISION
COMCAST	2940 SOUTH HENDERSON STREET
2940 SOUTH HENDERSON STREET	BLOOMINGTON, IN 47403
BLOOMINGTON, IN 47403	BLOOMINGTON, IN 47403
800N MAGACRE (317)334-4201	3001 TILBURNTON (317)335-3922
	1-(800)337-5344
	UNDERGROUND UTILITY LOCATION
	MANUAL UNDERGROUND
	PLANT PROTECTION
	1-(800)337-5344

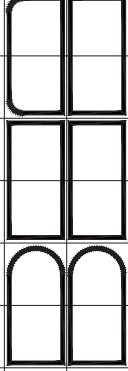

BYNUM FANYO & ASSOCIATES, INC.
528 North Walnut Street

Bloomington, Indiana 47404 (812) 332-8030

OWNER/DEVELOPER:
ROBERT STANCOMBE
7637 S. OLD SR 37
BLOOMINGTON, IN 47403

THE CURRENT EDITION OF THE INDIANA DEPARTMENT OF
TRANSPORTATION, MANUAL ON UNIFORM TRAFFIC CONTROL
DEVICES & CITY OF BLOOMINGTON UTILITIES STANDARD
SPECIFICATIONS IS TO BE USED WITH THESE PLANS

SHEET INDEX

SHEET NO.	SHEET NO.
C101	GENERAL NOTES & MISCELLANEOUS DETAILS
C201	DEMOLITION & SITE PLAN
C202	GRADING & UTILITY PLAN
C203	SWPP (EROSION CONTROL) PLAN
C204	LANDSCAPE PLAN
C301	MISCELLANEOUS DETAILS
C401	SWPPP (EROSION CONTROL) NARRATIVE & DETAILS
C402 & C403	SWPPP (EROSION CONTROL) DETAILS

VICINITY/LOCATION MAP
SCALE: 1"=1,000'

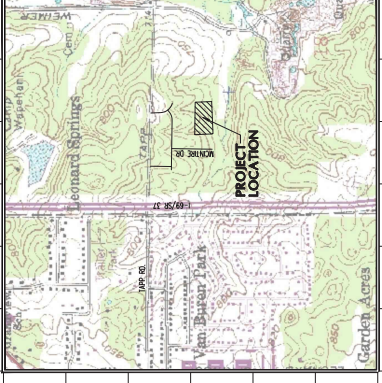

architecture
civil engineering
planning

Certified By: Revisions

2.11.19
JEFFREY S. FANYO, P.E.
IND. REG. NO. 60018283

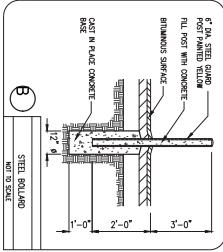
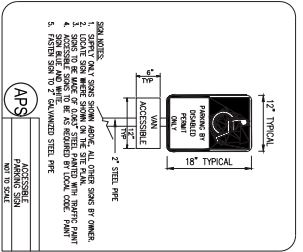
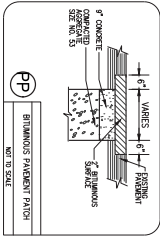
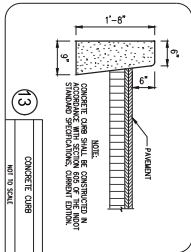
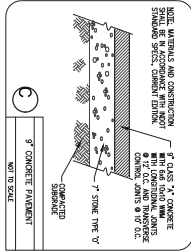
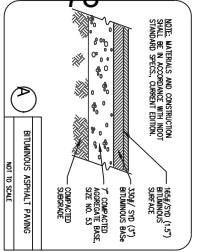

GENERAL NOTES

1. BOUNDARY AND TOP OF BRUMA FANED AND ASSOCIATES, 528 NORTH WALNUT STREET, BLOOMINGTON, INDIANA 47404. PHONE (812) 332-8030
2. DEVELOPER: ROBERT STAMCHOR, 7251 S. OLD ST. 37, BLOOMINGTON, IN 47403
3. PROJECT ADDRESS: 2917 S. MCINTIRE DR., BLOOMINGTON, INDIANA 47403
4. ALL WORK IS TO BE IN ACCORDANCE WITH ALL STATE AND LOCAL REGULATIONS.
5. ALL PERMITS ARE TO BE OBTAINED BY THE CONTRACTOR PRIOR TO THE START OF CONSTRUCTION.
6. IMPROVED LOCATIONS SHALL BE APPROVED BY THE LOCAL PERMITS OFFICE.
7. EXISTING UTILITIES ON SITE SHALL BE RECORDED AS REQUIRED BY CONSTRUCTION PERMITS AND ALL COSTS ASSOCIATED WITH RELOCATION.
8. SHEET CLEARLY MARKED REVISIONS AND VENDOR ACCESS TO ALL ADJACENT PROPERTIES MUST BE MAINTAINED THROUGHOUT THE CONSTRUCTION PROCESS.

PARKING AND PAVEMENT NOTES

1. ALL SIGNS, PAVEMENT MARKINGS, AND OTHER TRAFFIC CONTROL DEVICES SHALL BE IN ACCORDANCE WITH THE MANUAL ON UNIFORM TRAFFIC DEVICES, CURRENT EDITION AS APPLICABLE.
2. ALL DIMENSIONS ARE TO FACE OF PAVEMENT UNLESS INDICATED OTHERWISE.
3. CONTRACTOR SHALL FURNISH AND INSTALL PAVEMENT MARKINGS AS SHOWN ON THESE PLANS. CONTRACTOR SHALL BE RESPONSIBLE FOR THE PROTECTION OF ALL EXISTING UTILITIES AND OTHER TRAFFIC CONTROL DEVICES WITH OTHER CONTRACTORS ON THE SITE.
5. JOBS OR SCORE MARKS ARE TO BE SHARP AND CLEAR WITHOUT SHOWING EVIDENCE OF JAMMING TOOLS.
6. CONTRACTOR SHALL SOW-CUT TREES AT EXISTING CORNERS AS NECESSARY TO MAINTAIN EXISTING PAVEMENT AS NECESSARY AND AS DIRECTED BY INSPECTOR TO INSURE PROPER DRAINAGE (TYPICAL AT ALL INTERSECTIONS).
7. CONTRACTOR SHALL COMPLY WITH ALL PERTINENT PROVISIONS OF THE MANUAL ON UNIFORM TRAFFIC DEVICES, CURRENT EDITION AS APPLICABLE, WHICH ARE THE BASIS OF THE DESIGN AND CONSTRUCTION OF THIS PROJECT AS SET FORTH IN THE US DEPARTMENT OF LABOR.

GRADING NOTES

1. NEW FINISHED CONTOURS SHOWN ARE TO BE FURNISHED IN AREAS TO RECEIVE PAVEMENT AND TOP OF TOPSOIL IN AREAS TO BE SEEDED OR PLANTED.
2. AREAS OUTSIDE OF THE FINISHED LOT BOUNDARIES SHALL NOT BE SEEDED OR PLANTED UNLESS SPECIFICALLY NOTED ON THESE PLANS.
3. CONTRACTOR SHALL NOTIFY AND COOPERATE WITH ALL UTILITY COMPANIES OR AGENCIES HAVING FACILITIES ON OR ADJACENT TO THE SITE BEFORE DIGGING, ATTEMPTING TO LOCATE AND MARK ALL UTILITIES PRIOR TO CONSTRUCTION. THESE UTILITIES SHALL PAY ALL COSTS IN CONNECTION WITH ALTERATION OF OR RELOCATION OF THE FACILITY.
4. ALL AREAS NOT COVERED BY BUILDING OR PAVING ARE TO BE REVEALED (SEED OR REVEGETATION PLAN).
5. UNDESIRABLE EXCAVATED MATERIALS AND ALL WASTE RESULTING FROM CLEANING AND GRADING SHALL BE REMOVED FROM THE SITE.
6. BEFORE ANY WORK BEGINS, CONTRACTOR SHALL STAKE OUT AND MARK ALL POINTS DURING THE COURSE OF CONSTRUCTION. THE LACK OF PROPER MARKING SHALL BE RESPONSIBILITY OF THE CONTRACTOR.
7. THESE DOCUMENTS ARE SPECIFIC IN NATURE AND CANNOT SHOW EVERY ITEM NEEDED FOR A COMPLETE OPERATIONAL STORM SYSTEM. THE CONTRACTOR SHALL BE RESPONSIBLE FOR PROVIDING A COMPLETE OPERATIONAL STORM SYSTEM.
8. OTHER DETENTION MATERIALS TO BE USED SHALL BE APPROVED BY THE DESIGNER AND NOT TO EXCEED 30 (30) INCHES IN LOOSE THICKNESS AND SHOULD BE SPANNED WITH UNBURNED COMPACTED OR BLENDED SURFACE EQUIPMENT AS DIRECTED BY THE DESIGNER. EXCESS OF WATER SHOULD BE SPREAD AND DRED TO 4 INCHES. CONTRACTOR SHALL REMOVE EXCESS OF WATER FROM CONSTRUCTION. ALL TIES SHOULD BE CONDUCTED TO THE SPECIFIED POINTS OF CONNECTION. CONTRACTOR SHALL BE RESPONSIBLE FOR THE PROTECTION OF ALL UTILITIES DURING THE CONSTRUCTION. CONTRACTOR SHALL BE RESPONSIBLE FOR THE PROTECTION OF ALL UTILITIES DURING THE CONSTRUCTION.

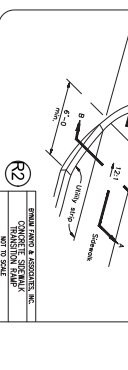
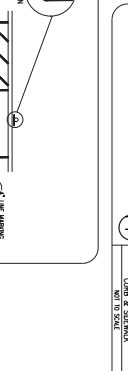
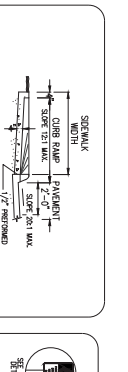
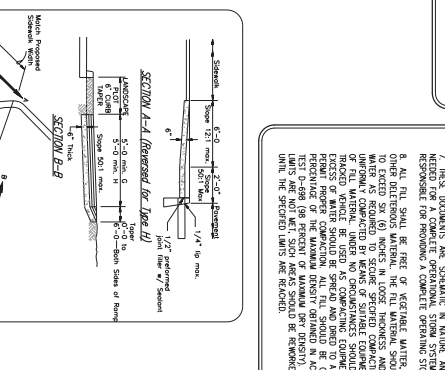
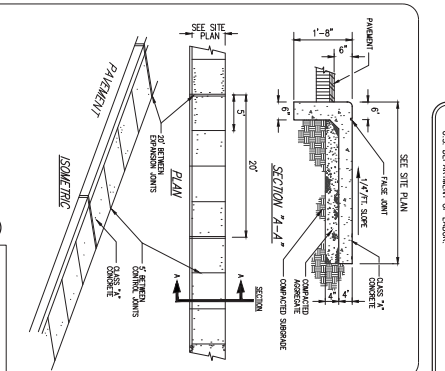
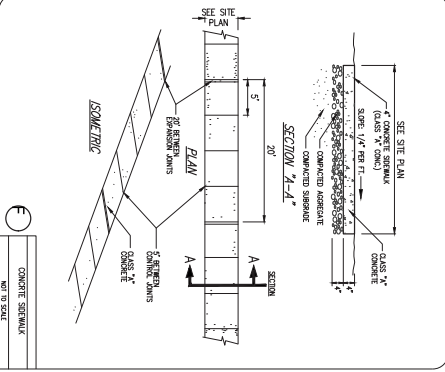

ON-SITE UTILITY NOTES

1. ALL WATER PIPE 6" AND LARGER SHALL BE PRESSURE CLASS 350 PER WATER PIPE COMPOUND TO ALL STATE AND LOCAL REGULATIONS.
2. WATER MAINS SHALL BE 6" AND LARGER SHALL BE DUCTILE IRON CONFORMING TO AASHTO M 254 OR 255 (ASTM A 1332) LATEST REVISION.
3. 4" AND 6" WATER MAINS SHALL BE 4" AND 6" PERMITS SHALL BE OBTAINED BY THE CONTRACTOR PRIOR TO THE START OF CONSTRUCTION.
4. RELOCATION, REPAIRS, SHALL BE INSTALLED ON ALL WATER MAINS. JOINTS AT BENDS, OFFSETS, AND TEES, ETC., WITHIN THE LENGTHS SPECIFIED IN THE MECHANICAL JOINT RESTRAINT TABLE ON SHEET 2022. EXISTING WATER MAINS SHALL BE CUT AND RELOCATED TO THE NEW LOCATION. THE CONTRACTOR SHALL BE RESPONSIBLE FOR THE PROTECTION OF ALL UTILITIES DURING THE CONSTRUCTION.
5. AIR RELEASE VALVES SHALL BE PROVIDED AT ALL HIGH POINTS OF WATER MAINS AND SHALL BE VALVE-LESS BRAND AND SHALL INCORPORATE THE ORIGINAL MANUFACTURER'S CHECK FEATURE.
7. ALL FIRE HYDRANTS SHALL BE MANUFACTURED BY KENNEDY GRADYON OR KENNEDY GRADYON.
8. ALL WATER MAINS SHALL BE PROTOTYPICALLY TESTED AND DIRECTED BEFORE CONSTRUCTION.
9. WATER AND SEWER SERVICES SHALL HAVE A MINIMUM COVER OF 4'-0" ABOVE TOP OF PIPE.
10. ALL SPOCKERS, HOISTERS, AND SIMILAR LOADS TO THE BUILDING SHALL NOT BE SHOWN ON PLAN AND SHALL BE PROVIDED WITH A TEMPORARY PLUG AT THE END (FOR HORIZONTAL SEPARATION BETWEEN THE CLOSEST TWO POINTS OF SEPARATION BETWEEN THE CLOSEST TWO POINTS OF THE WATER AND SEWER LINES OF EIGHTEEN INCHES (18").
12. GRAVITY SANITARY SEWER PIPE 6" TO 15" SHALL BE CONSTRUCTED OF SMP-35 PVC.
13. ALL TRENCHING, PIPE LAYING, AND BACKFILLING SHALL BE IN ACCORDANCE WITH LOCAL CODE REGULATIONS.
15. SEE SITE SPECIFICATIONS FOR BOUNDARIES AND COMPACTING REQUIREMENTS.
16. SET CONTRACTOR SHALL HAVE APPROVAL OF ALL CONVEYING AGENCIES HAVING JURISDICTION OVER THIS SYSTEM PRIOR TO INSTALLATION.
17. CONTRACTOR SHALL COMPLY WITH ALL PERTINENT PROVISIONS OF THE MANUAL ON UNIFORM TRAFFIC DEVICES, CURRENT EDITION AS APPLICABLE, WHICH ARE THE BASIS OF THE DESIGN AND CONSTRUCTION OF THIS PROJECT AS SET FORTH IN THE US DEPARTMENT OF LABOR.
18. ALL CATCH BASIN GRATE AND FRAMES ARE TO BE BY CAST IRON PER MANS.
19. LOCATIONS OF EXISTING BURIED UTILITY LINES SHOWN ON THE PLANS ARE BASED UPON BEST AVAILABLE INFORMATION AND ARE TO BE CONSIDERED AS APPROXIMATE. CONTRACTOR SHALL VERIFY THE LOCATION OF ALL UTILITIES PRIOR TO CONSTRUCTION. CONTRACTOR SHALL BE RESPONSIBLE FOR THE PROTECTION OF ALL UTILITIES DURING THE CONSTRUCTION.
20. BEFORE CONSTRUCTION SHALL REMOVE A MINIMAL A MINIMUM DISTANCE OF 20' FROM ALL UTILITIES. CONTRACTOR SHALL BE RESPONSIBLE FOR THE PROTECTION OF ALL UTILITIES DURING THE CONSTRUCTION.
21. ALL PROJECTS WILL REQUIRE A PRE-CONSTRUCTION MEETING WITH THE CITY OF BLOOMINGTON AND THE CITY OF BLOOMINGTON UTILITIES ENGINEERING DEPARTMENT. THE MEETING SHALL BE HELD AT THE CITY OF BLOOMINGTON AND/OR DEVELOPER MUST CONTACT THE UTILITIES ENGINEERING DEPARTMENT AT (812) 334-2676 TO SCHEDULE THE MEETING WHICH WILL BE HELD AT THE CITY OF BLOOMINGTON UTILITIES ENGINEERING OFFICE.
22. CONTRACTOR SHALL NOTIFY THE CITY OF BLOOMINGTON UTILITIES ENGINEERING DEPARTMENT AND THE CITY OF BLOOMINGTON UTILITIES ENGINEERING DEPARTMENT PRIOR TO THE START OF CONSTRUCTION. CONTRACTOR SHALL BE RESPONSIBLE FOR THE PROTECTION OF ALL UTILITIES DURING THE CONSTRUCTION.
23. CONTRACTOR SHALL NOTIFY THE CITY OF BLOOMINGTON UTILITIES ENGINEERING DEPARTMENT AND THE CITY OF BLOOMINGTON UTILITIES ENGINEERING DEPARTMENT PRIOR TO THE START OF CONSTRUCTION. CONTRACTOR SHALL BE RESPONSIBLE FOR THE PROTECTION OF ALL UTILITIES DURING THE CONSTRUCTION.

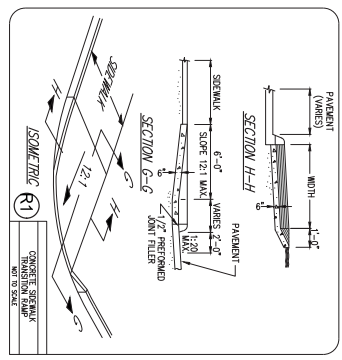
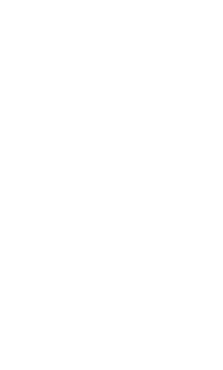
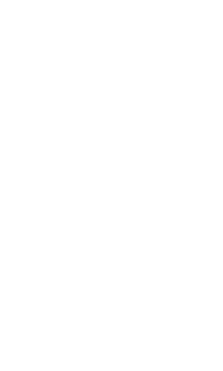
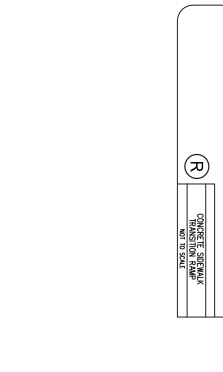
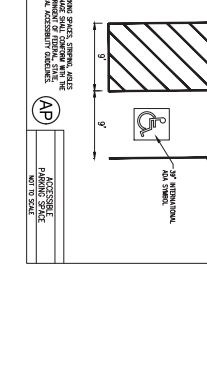
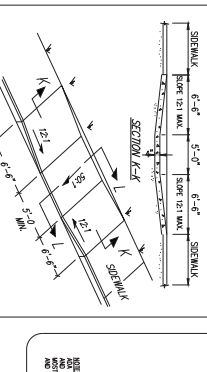

PROPOSED PROGRESS CONSTRUCTION & DEVELOPMENT, INC - SIMP
 2917 S. MCINTIRE DRIVE
 BLOOMINGTON, INDIANA 47403

ARCHITECTURE CIVIL ENGINEERING PLANNING
 BRYNUM FANYO & ASSOCIATES, INC.
 528 North Walnut Street
 (812) 332-8030
 Bloomington, Indiana
 (812) 336-2990 (FAX)

Designed by: JBT
 Drawn by: JBT
 Checked by: JSF
 Sheet no: C101
 Project no.: 401542

Checked by:
 2/1/19

DEMOLITION LEGEND

T.B.R.	TO BE REMOVED
T.R.U.	TO REMAIN UNDISTURBED

EXISTING LEGEND

---	PROPERTY LINE
X	FENCE
W/W	WATER LINE PIPE, SIZE AS INDICATED
CONTOUR	CONTOUR & ELEVATION
SSS	SANITARY SEWER PIPE
XSS	STORM SEWER PIPE, SIZE AS INDICATED
XOHE	OVERHEAD ELECTRIC LINES
XUGE	UNDERGROUND ELECTRIC LINES
XOHT	OVERHEAD TELEPHONE LINES
XUGT	UNDERGROUND TELEPHONE LINES
XGAS	GAS LINE PIPE

SITE LEGEND

A	BITUMINOUS PAVEMENT
AP	ADA ACCESSIBLE PARKING SPACE
APC	ADA ACCESSIBLE PARKING SIGN
R	REINFORCED CONCRETE PAVING
S	CONCRETE SIDEWALK
M	MONOLITHIC CONCRETE CURB AND SIDEWALK
L	LAWN OR LANDSCAPE AREA
W	MATCH EXISTING CURB, SIDEWALK, PAVEMENT ELEVATIONS
PR	STANDARD ROAD PAVEMENT PATCH
PS	3 FT WIDE CONCRETE PAVED SIDE DITCH
RA	SIDEWALK ADA ACCESSIBLE RAMP, STYLES 1-4
VA	VAN ACCESSIBLE SUPPLEMENTAL SIGN
1	6-IN WIDE CONCRETE CURB
2	4-IN WIDE SOLID BLUE PAINTED ADA PAVEMENT MARKING
3	4-IN WIDE SOLID WHITE PAINTED ADA PAVEMENT MARKING
CL	OR CL CONSTRUCTION LIMITS

UTILITY LEGEND

6W	6" DIP FIRE SERVICE LINE (PRIVATELY OWNED)
DSL	8" SDR-27 PVC DOMESTIC WATER SERVICE LINE (PRIVATELY OWNED)
M	6" WATER LINE GATE VALVE
6SL	6" SDR-35 PVC SANITARY SEWER LATERAL (PRIVATELY OWNED)
ST	48" BRAND SERIES N-12 HOPE STORM SEWER PIPE (PRIVATELY OWNED)
BD	50K-35 PVC BUILDING/DOWNSPOUT DRAIN PIPE (PRIVATELY OWNED)
GAS	GAS SERVICE LINE
ELEC	ELECTRIC SERVICE LINE - SEE NOTE THIS SHEET

revisions:

SCALE: 1"=20'

ARCHITECTURE
CIVIL ENGINEERING
PLANNING

BBS
BRUNNEN FANTO S. ASSOCIATES, INC.

2017 S. MOUNTAIN DRIVE
BLOOMINGTON, INDIANA 47403
(812) 332-6030

certified by:

**PROPOSED
PROGRESS CONSTRUCTION &
DEVELOPMENT, INC. - SIMP**

2017 S. MOUNTAIN DRIVE
BLOOMINGTON, INDIANA 47403

title: SITE & DEMOLITION
PLANS

designed by: JBT
drawn by: JBT
checked by: JSF
sheet no: C201
project no: 401542

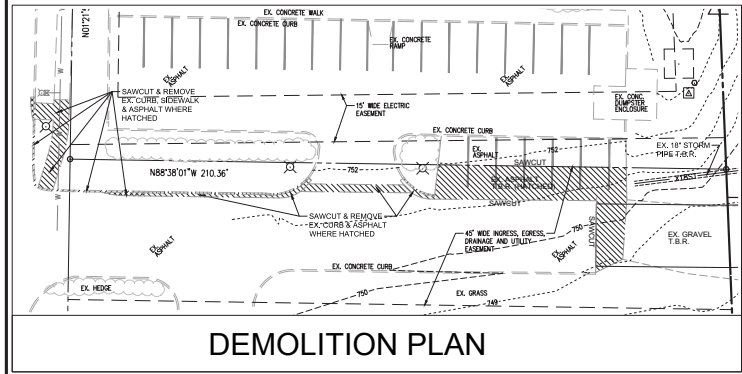
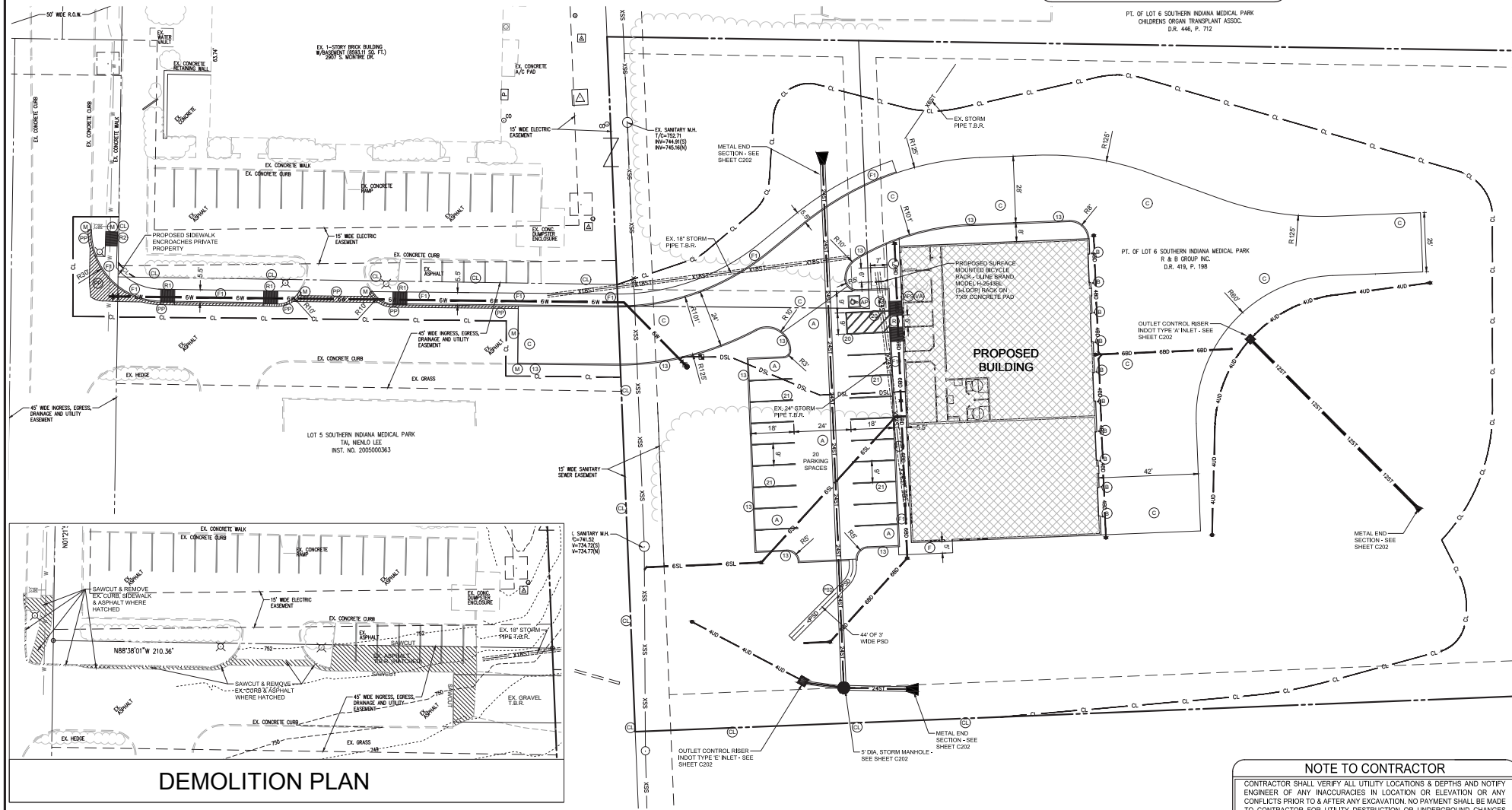

NOTE TO CONTRACTOR

CONTRACTOR SHALL VERIFY ALL UTILITY LOCATIONS & DEPTHS AND NOTIFY ENGINEER OF ANY INACCURACIES IN LOCATION OR ELEVATION OR ANY CONFLICTS PRIOR TO & AFTER ANY EXCAVATION. NO PAYMENT SHALL BE MADE TO CONTRACTOR FOR UTILITY DESTRUCTION OR UNDERGROUND CHANGES REQUIRED DUE TO CONFLICTING ELEVATIONS.

revisions:

SCALE: 1"=20"

ARCHITECTURE
CIVIL ENGINEERING
PLANNING

Bloomington, Indiana
(812) 338-2880 (PB)

BRUNNEN FANTO S. ASSOCIATES, INC.

528 North Central Street
(812) 332-8018

certified by:

2/1/19

PROPOSED
PROGRESS CONSTRUCTION &
DEVELOPMENT, INC. - SIMP

2017 S. MOUNTAIN DRIVE
BLOOMINGTON, INDIANA 47403

Title: GRADING & UTILITY
PLAN

designed by: JBT
drawn by: JBT
checked by: JSF
sheet no: C202
project no: 401542

NOTES:
ALL PROJECTS WILL REQUIRE A PRE-CONSTRUCTION MEETING WITH THE CITY OF BLOOMINGTON UTILITIES PRIOR TO THE START OF CONSTRUCTION. THE CONTRACTOR AND/OR DEVELOPER MUST CONTACT THE UTILITIES TO OBTAIN ALL UTILITIES TO BE SCHEDULED. THE MEETING WHICH WILL BE HELD AT THE CITY OF BLOOMINGTON UTILITIES OFFICE.
CONTRACTOR SHALL NOTIFY THE CITY OF BLOOMINGTON UTILITIES ENGINEERING DEPARTMENT ONE (1) WORKING DAY PRIOR TO CONSTRUCTION OF ANY WATER, STORM OR SANITARY SEWER UTILITY WORK. A CSU INSPECTOR MUST HAVE NOTICE OF WORK ON BE INSPECTED, DOCUMENTED, AND PROPER ASBESTOS TAGS. WHEN A CONTRACTOR WORKS WITHIN A CBU IDENTIFIED AS LAY, OR BEYOND NORMAL CBU WORK HOURS, THE CONTRACTOR WILL ADVISE FOR THE INSPECTORS OVERTIME, FOR CBU WORK HOURS AND HOLIDAY INFORMATION, PLEASE CONTACT THE CITY OF BLOOMINGTON UTILITIES ENGINEERING DEPARTMENT AT (317) 264-8860.

EXISTING LEGEND

---	PROPERTY LINE
X	FENCE
X W	WATER LINE PIPE, SIZE AS INDICATED
---	CONTOUR & ELEVATION
XSS	SANITARY SEWER PIPE
X ST	STORM SEWER PIPE, SIZE AS INDICATED
X HE	OVERHEAD ELECTRIC LINES
X MT	OVERHEAD TELEPHONE LINES
X GT	UNDERGROUND TELEPHONE LINE
X GAS	GAS LINE PIPE

GRADING LEGEND

---	PROPOSED ELEVATION CONTOUR
FL >	FLOWLINE
---	SPOT GRADE ELEVATION
XXX.XX	TOP OF CURB ELEVATION OVER PAVEMENT ELEVATION
FF=XXX.XX	FINISH FLOOR ELEVATION
FG=XXX.XX	FINISH EARTH GRADE ELEVATION
FP=XXX.XX	FINISH PAVEMENT ELEVATION
FW=XXX.XX	FINISH WALK ELEVATION
T/C or TC=XXX.XX	FINISH TOP OF CASTING AT THE FLOW LINE

UTILITY LEGEND

---	6" DP FIRE SERVICE LINE (PRIVATELY OWNED)
---	6" DSL
M	6" SDR-21 PVC DOMESTIC WATER SERVICE LINE (PRIVATELY OWNED)
---	6" WATER LINE GATE VALVE
---	6" SDR-20 PVC SANITARY SEWER LATERAL (PRIVATELY OWNED)
---	5T
---	SDR-35 PVC BUILDING/DOWNPOUT DRAIN PIPE (PRIVATELY OWNED)
---	GAS
---	ELEC
---	ELECTRIC SERVICE LINE - SEE NOTE THIS SHEET

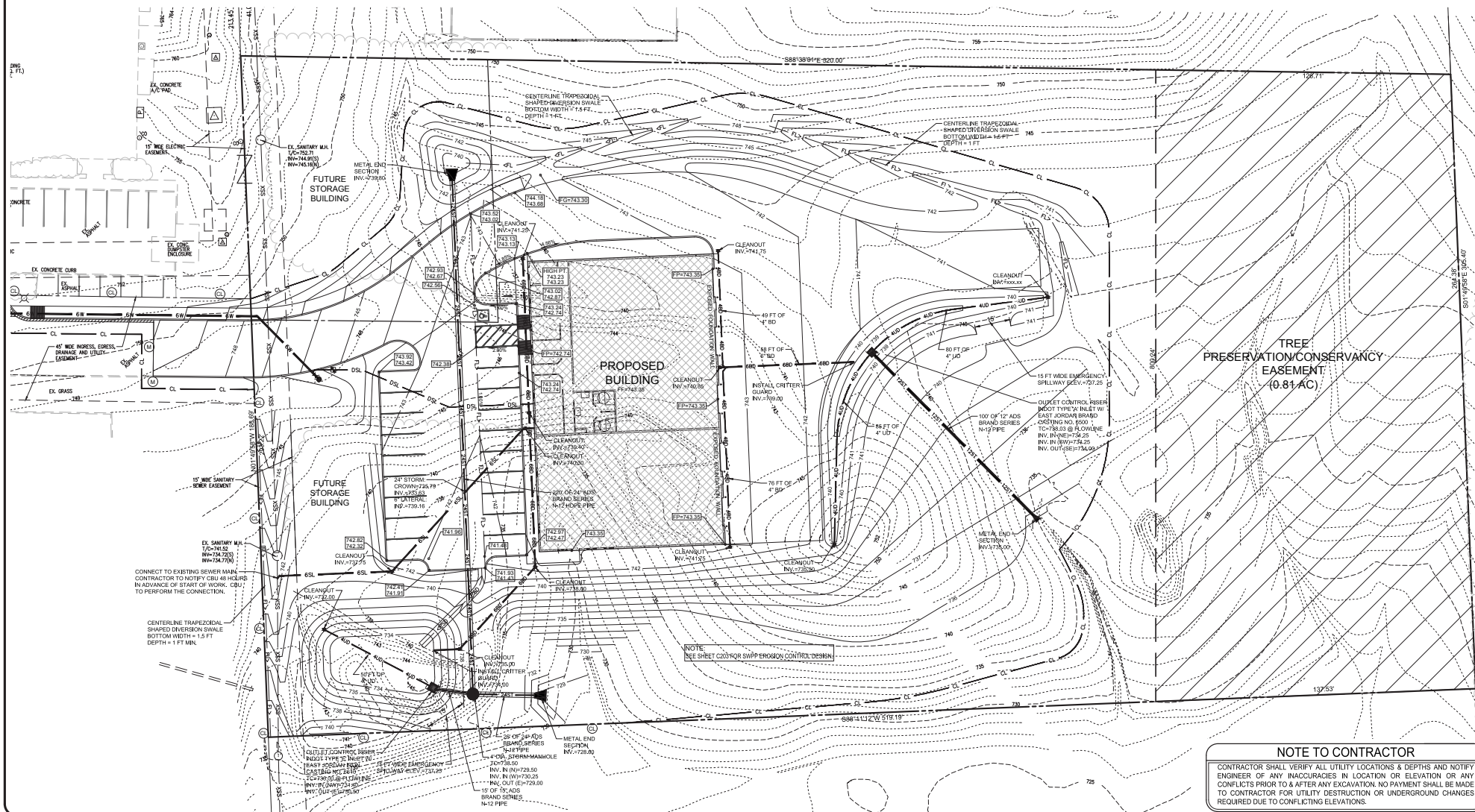

NOTE TO CONTRACTOR

CONTRACTOR SHALL VERIFY ALL UTILITY LOCATIONS & DEPTHS AND NOTIFY ENGINEER OF ANY INACCURACIES IN LOCATION OR ELEVATION OR ANY CONFLICTS PRIOR TO & AFTER ANY EXCAVATION. NO PAYMENT SHALL BE MADE TO CONTRACTOR FOR UTILITY DESTRUCTION OR UNDERGROUND CHANGES REQUIRED DUE TO CONFLICTING ELEVATIONS.

revisions:

SCALE: 1"=20"

EXISTING LEGEND

---	PROPERTY LINE
x	FENCE
---#---	WATER LINE PIPE, SIZE AS INDICATED
---###---	CONTOUR & ELEVATION
---	SANITARY SEWER PIPE
---	STORM SEWER PIPE, SIZE AS INDICATED
---	OVERHEAD ELECTRIC LINES
---	UNDERGROUND ELECTRIC LINES
---	OVERHEAD TELEPHONE LINES
---	UNDERGROUND TELEPHONE LINES
---	GAS LINE PIPE

EROSION CONTROL LEGEND

CL	CONSTRUCTION LIMITS
SF	SILTATION FENCE (TEMPORARY)
CD	ROCK CHECK DAM (TEMPORARY)
ECB	CONCRETE WASHOUT AREA (TEMPORARY)
MS	EROSION CONTROL BLANKET (TEMPORARY)
MS	MULCH SEEDING - SEE SPECIFICATIONS (TEMPORARY & PERMANENT)
RR	ROCK RIP RAP ON FILTER FABRIC (PERMANENT)
SW	WATER QUALITY POND SEEDING (PERMANENT)
SP	20' x 100' STONE PAD, 6" DEEP (TEMPORARY)
TRM	TURF REINFORCEMENT MATTING (PERMANENT)

ARCHITECTURE
CIVIL ENGINEERING
PLANNING

BFA
BRUNLUN FANTO & ASSOCIATES, INC.

528 North Walnut Street
Bloomington, Indiana 47403
(812) 332-2800 (FAX)

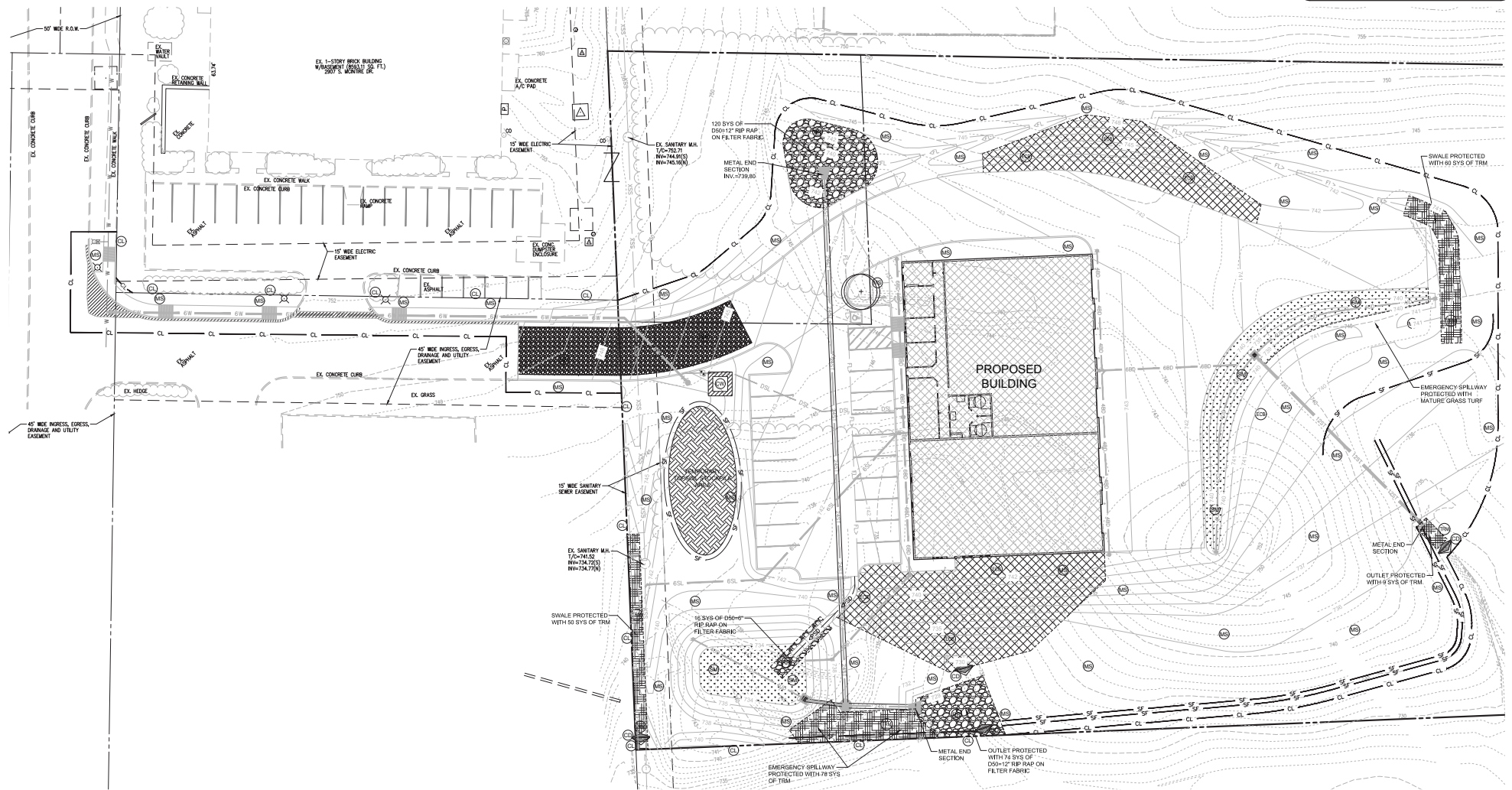

certified by:

2.11.19

**PROPOSED
PROGRESS CONSTRUCTION &
DEVELOPMENT, INC. - SIMP**

2817 S. MOUNTAIN DRIVE
BLOOMINGTON, INDIANA 47403

title: SWPP (EROSION CONTROL) PLAN

designed by: JBT
drawn by: JBT
checked by: JSF
sheet no.: C203
project no.: 401542

NOTE TO CONTRACTOR

CONTRACTOR SHALL VERIFY ALL UTILITY LOCATIONS & DEPTHS AND NOTIFY ENGINEER OF ANY INACCURACIES IN LOCATION OR ELEVATION OR ANY CONFLICTS PRIOR TO & AFTER ANY EXCAVATION. NO PAYMENT SHALL BE MADE TO CONTRACTOR FOR UTILITY DESTRUCTION OR UNDERGROUND CHANGES REQUIRED DUE TO CONFLICTING ELEVATIONS.

LANDSCAPE CALCULATIONS

LOT IS WITHIN A "PUD" ZONING WAS USED.
 FOR THESE CALCULATIONS "MD" ZONING WAS USED.
 OVERALL OPEN SPACE = 111,155.95 SF (2.55 AC)
 TOTAL PARKING SPACES = 20
STREET TREES (REQUIRED): NONE REQUIRED.
PERIMETER PLANTINGS (REQUIRED):
 TOTAL TREES = (7)(1) = 5
 LARGE CANOPY TREES = 75%(5) = 4 (8 PROVIDED)
 ORNAMENTAL TREES = 5 - 4 = 1 (1 PROVIDED)
 TOTAL SHRUBS = (20)(3) = 60
 EVERGREEN SHRUBS = 50%(60) = 30 (30 PROVIDED)
 DECIDUOUS SHRUBS = 60 - 30 = 30 (30 PROVIDED)
INTERIOR PLANTINGS (REQUIRED):
 LARGE CANOPY TREES = 2.55(9) = 23 (FULL CREDIT FOR TREE PRESERVATION AREA)
 EVERGREEN TREES = 2.55(3) = 8 (8 EVERGREEN TREES PROVIDED)
 SMALL DECIDUOUS TREES = 2.55(3) = 8 (8 PROVIDED)
 TOTAL SHRUBS = 2.55(27) = 69 (CREDIT FOR 50% OF SHRUBS FROM TREE PRESERVATION AREA)
 EVERGREEN SHRUBS = 50%(69) = 35 (18 PROVIDED)
 DECIDUOUS SHRUBS = 69 - 35 = 34 (17 PROVIDED)

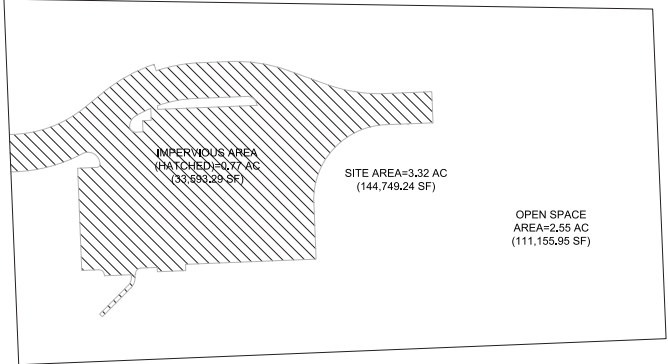

NOTE TO CONTRACTOR

CONTRACTOR SHALL VERIFY ALL UTILITY LOCATIONS & DEPTHS AND NOTIFY ENGINEER OF ANY INACCURACIES IN LOCATION OR ELEVATION OR ANY CONFLICTS PRIOR TO & AFTER ANY EXCAVATION. NO PAYMENT SHALL BE MADE TO CONTRACTOR FOR UTILITY DESTRUCTION OR UNDERGROUND CHANGES REQUIRED DUE TO CONFLICTING ELEVATIONS.

PLANT LIST

LARGE CANOPY DECIDUOUS TREES							
LEGEND	KEY	BOTANICAL NAME	COMMON NAME	QTY	SIZE & CONDITION		
[Symbol]	AN	ACER NEGUNDO	BLACK MAPLE	2	2" CAL. 8' & 8'		
	AR	ACER RUBRUM	RED MAPLE	1	2" CAL. 8' & 8'		
	LT	LIRIODENDRON TULIPIFERA	TULIP TREE	1	2" CAL. 8' & 8'		
	AG	ACER SACCHARINUM	SUGAR MAPLE	1	2" CAL. 8' & 8'		
					AMERICAN BEECH	1	2" CAL. 8' & 8'
SMALL (ORNAMENTAL) DECIDUOUS TREES							
LEGEND	KEY	BOTANICAL NAME	COMMON NAME	QTY	SIZE & CONDITION		
[Symbol]	OC	EASTERN REDBUD	CERES CANADENSE	5	2" CAL. 8' & 8'		
	FD	CORNUS FLORIDA	FLOWERING DOGWOOD	4	2" CAL. 8' & 8'		
SMALL (ORNAMENTAL) DECIDUOUS TREES							
LEGEND	KEY	BOTANICAL NAME	COMMON NAME	QTY	SIZE & CONDITION		
[Symbol]	PV	PRINUS VIRGINIANA	VIRGINIA PINE	4	6" HEIGHT		
	PS	PRINUS STROBOS	WHITE PINE	4	6" HEIGHT		
DECIDUOUS SHRUBS							
LEGEND	KEY	BOTANICAL NAME	COMMON NAME	QTY	SIZE & CONDITION		
[Symbol]	I	ILEX VERTICILLATA	WINTERBERRY HOLLY	11	3 GAL. CONTAINER OR 18" HT		
	CD	COFFEA ARABICA	COFFEE	10	3 GAL. CONTAINER OR 18" HT		
	HO	HYDRANGIA QUERCIFOLIA	OH OLEAF HYDRANGIA	7	3 GAL. CONTAINER OR 18" HT		
	LB	LINDERA BENZONIN	SPICE BUSH	6	3 GAL. CONTAINER OR 18" HT		
					PHYSCARPUS OPULENTOSUS	13	3 GAL. CONTAINER OR 18" HT
EVERGREEN SHRUBS							
LEGEND	KEY	BOTANICAL NAME	COMMON NAME	QTY	SIZE & CONDITION		
[Symbol]	RS	RHODODENDRON SPECIES	RHODODENDRON	15	3 GAL. CONTAINER OR 18" HT		
	TC	TAXUS CANADENSIS	CANADIAN YEW	17	3 GAL. CONTAINER OR 18" HT		
	BC	BOUXIA GREEN VELVET	GREEN VELVET BOXWOOD	16	3 GAL. CONTAINER OR 18" HT		

[Symbol] PLANT QUANTITY
 [Symbol] PLANT TYPE
 [Symbol] REQUIREMENT DESIGNATION
 [Symbol] EXISTING TREE
 [Symbol] STREET TREES
 [Symbol] PARKING LOT PERIMETER PLANTINGS
 [Symbol] INTERIOR PLANTINGS

*CONTAINER OR BALL AND BURLAP CONDITION ACCEPTABLE

revisions:



ARCHITECTURE
 CIVIL ENGINEERING
 PLANNING

B&B
 BRUNNEN FANTO S. ASSOCIATES, INC.
 528 North Walnut Street
 Bloomington, Indiana
 (812) 339-2390 (FAX)

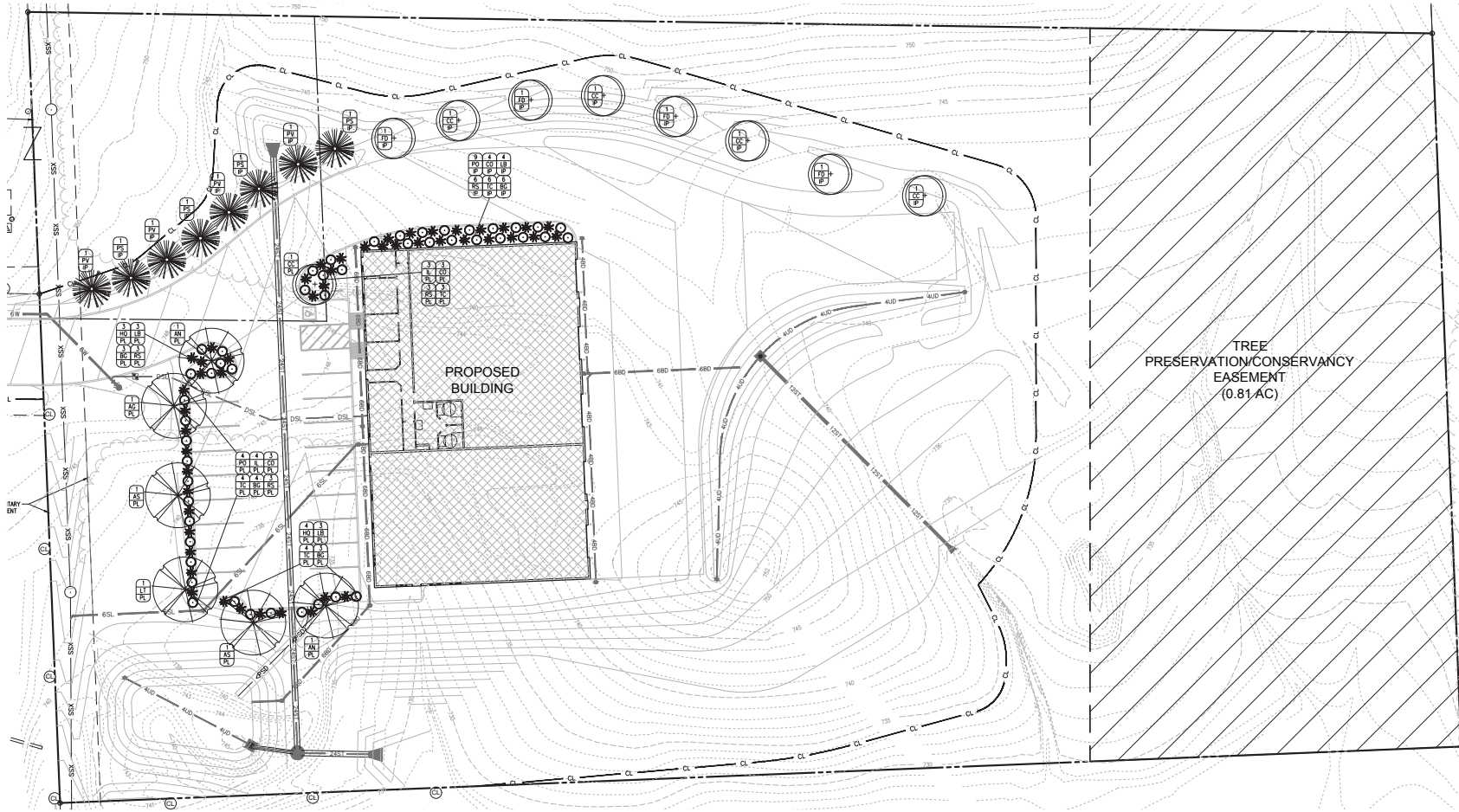

certified by:

**PROPOSED
 PROGRESS CONSTRUCTION &
 DEVELOPMENT, INC. - SIMP**
 2017 S. MOUNTAIN DRIVE
 BLOOMINGTON, INDIANA 47403

Title: LANDSCAPE PLAN

designed by: DJB
 drawn by: DJB
 checked by: JSF
 sheet no: C204
 project no: 401542

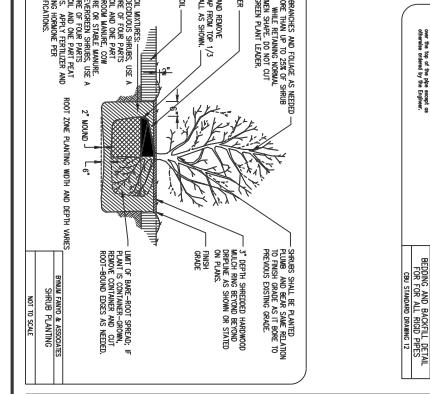
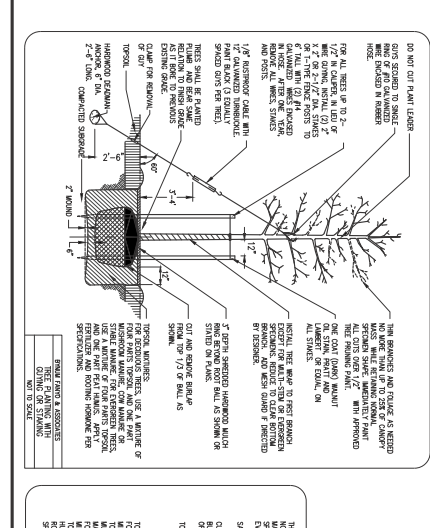
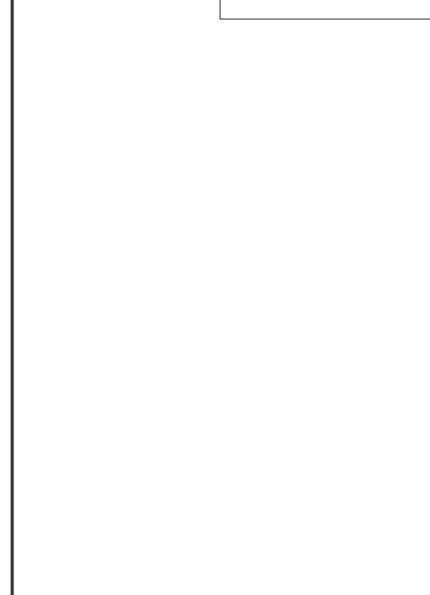
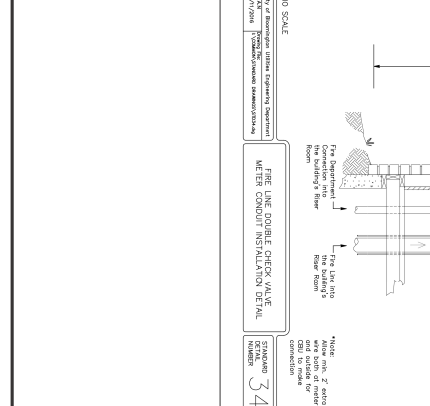
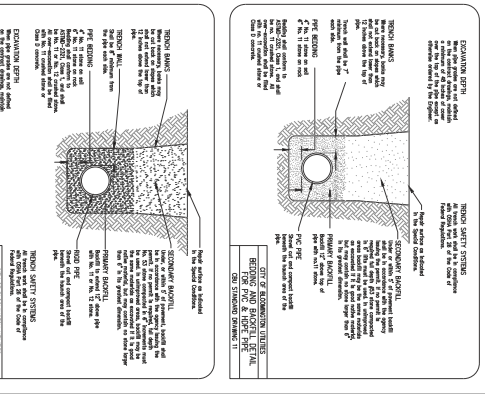
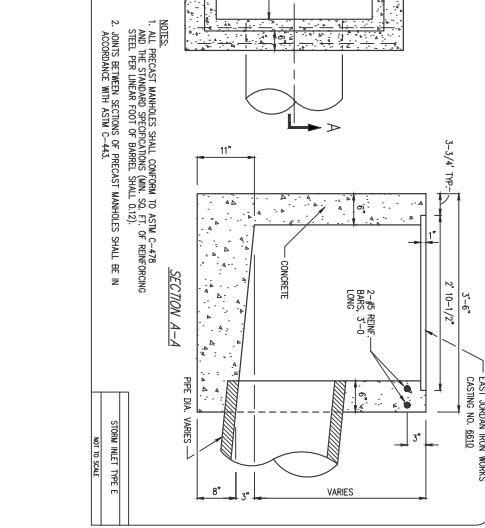
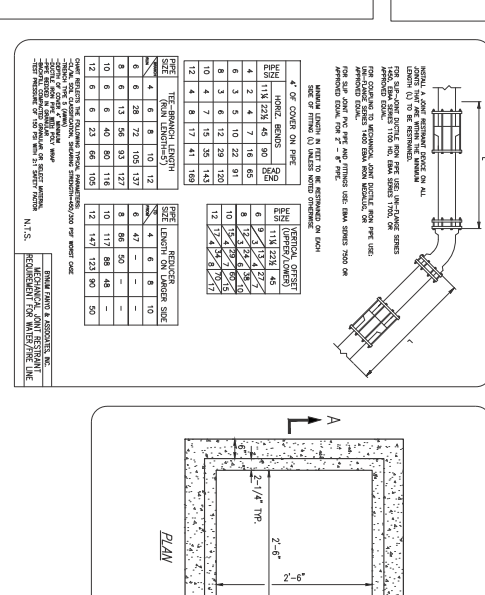
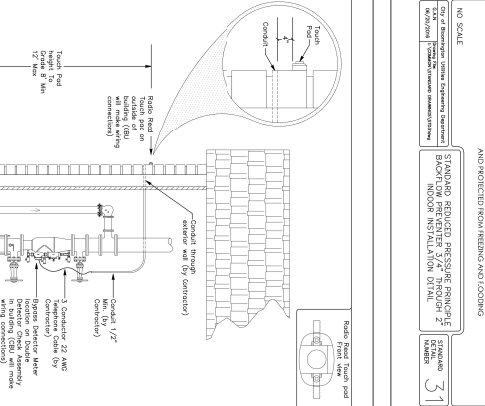
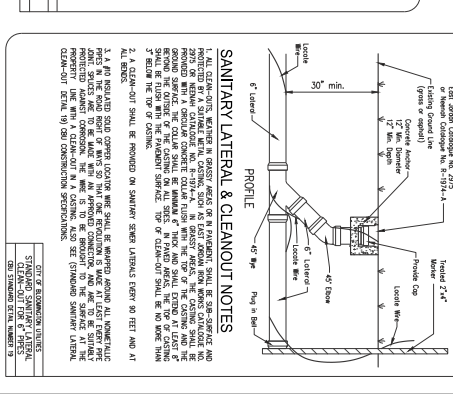
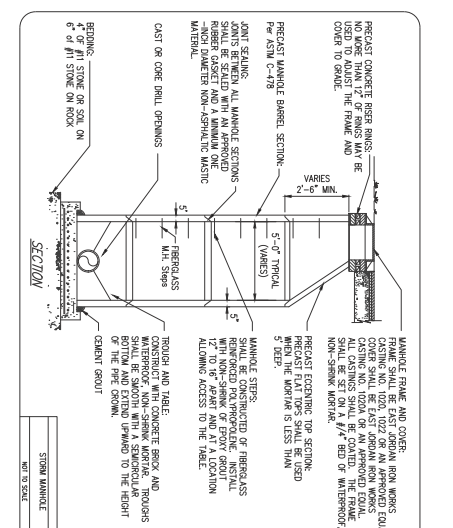
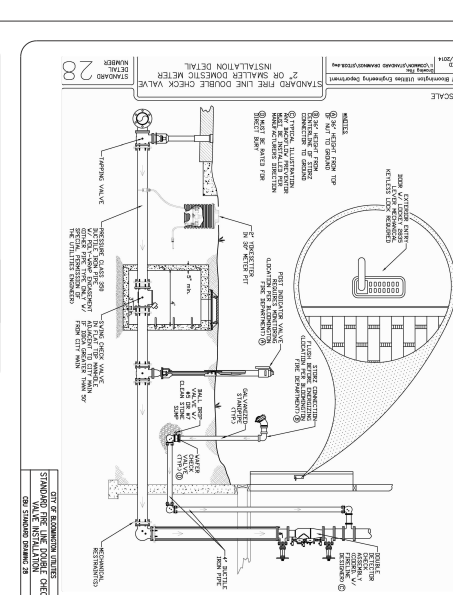
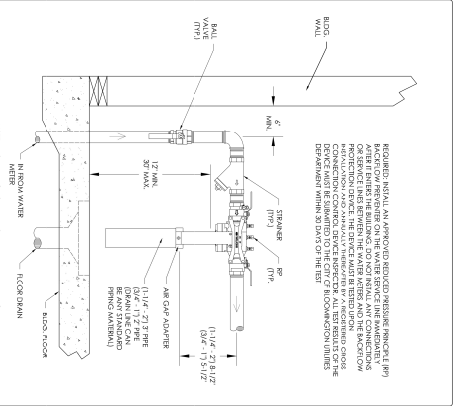

DESIGNED BY: JBT
 DRAWN BY: JBT
 CHECKED BY: JSF
 SHEET NO: C201
 PROJECT NO.: 401542

PROPOSED
 PROGRESS CONSTRUCTION &
 DEVELOPMENT, INC - SIMP
 2917 S. MCINTIRE DRIVE
 BLOOMINGTON, INDIANA 47403

ARCHITECTURE
 CIVIL ENGINEERING
 PLANNING
 BYNUM FANYO & ASSOCIATES, INC.
 528 North Walnut Street
 (812) 332-8030
 Bloomington, Indiana
 (812) 339-2990 (Fax)

City of Bloomington Engineering Department
 Engineering Division
 1300 W. Washington Blvd.
 Bloomington, Indiana 47403
 Project No. 401542

RULE 5 NARRATIVE

SECTION A - CONSTRUCTION PLAN ELEMENTS

- A1. PLAN INDEX SHOWING LOCATIONS OF REQUIRED ITEMS: REFER TO THIS NARRATIVE.
- A2. 11 X 17 INCH PLAT SHOWING BUILDING LOT NUMBER/BOUNDARIES AND ROAD LAYOUT/NAMES UNDER SEPARATE COVER
- A3. NARRATIVE DESCRIBING PROJECT NATURE AND PURPOSE: THIS PROJECT WILL CONSIST OF THE CONSTRUCTION OF A NEW COMMERCIAL BUILDING AND PARKING LOT IMPROVEMENTS INCLUDING BUT NOT LIMITED TO THE FOLLOWING: ROADWAY INTERSECTION IMPROVEMENTS.
- A4. VONITY MAP SHOWING PROJECT LOCATION: REFER TO COVER SHEET.
- A5. LEGAL DESCRIPTION: NW QUARTER SECTION 18, TOWNSHIP 8 NORTH, RANGE 1 WEST IN PERRY TWP, MONROE COUNTY, INDIANA. 39.1343220 / 86758148.W.
- A6. LOCATION OF ALL LOTS AND PROPOSED SITE IMPROVEMENTS: LOCATION OF PROPOSED SITE IMPROVEMENTS IS INDICATED ON PLAN SHEETS C201 THROUGH C204. DEMOLITION AND RECONSTRUCTION OF EXISTING OFFSITE CURB, SIDEWALK AND PAVEMENT IS SHOWN ON SHEET C201.
- A7. HYDROLOGIC UNIT CODE: 0512020809010.
- A8. NOTATION OF ANY STATE OR FEDERAL WATER QUALITY PERMITS: NO OTHER STATE OR FEDERAL PERMITS ARE REQUIRED FOR THIS PROJECT.
- A9. SPECIFIC POINTS WHERE STORM WATER DISCHARGE WILL LEAVE THE SITE: SEE PLAN SHEET C202 & C203 FOR DETAILS.
- A10. LOCATION AND NAME OF ALL WETLANDS, LAKES, AND WATERCOURSES ON/OR ADJACENT TO THE SITE: THERE ARE NO WETLANDS, LAKES OR WATERCOURSES ON OR IMMEDIATELY ADJACENT TO THE SITE.
- A11. IDENTIFY ALL RECEIVING WATERS: WEST FORK CLEAR CREEK.
- A12. IDENTIFICATION OF POTENTIAL DISCHARGES TO GROUNDWATER: THERE IS NO EVIDENCE OF ANY CAVES OR SINHOLES WITHIN THE CONSTRUCTION LIMITS.
- A13. 100 YEAR FLOOD PLAINS, FLOODWAYS, AND FLOODWAY FRANCES: THERE ARE NO REGULATED FLOODPLAINS, FLOODWAYS OR FRANCES WITHIN THE PROPERTY LIMITS.
- A14. PRE-CONSTRUCTION AND POST CONSTRUCTION ESTIMATE OF PEAK DISCHARGE: 100 YEAR PRE=4.72 / 100 YEAR POST=12.08 CFS
- A15. ADJACENT LAND USE, INCLUDING UPSTREAM WATERSHEDS: ADJACENT LAND USES CONSIST OF MEDICAL USES TO THE NORTH AND WEST, MATURE FOREST TO THE SOUTH AND EAST.
- A16. LOCATIONS AND APPROXIMATE BOUNDARIES OF ALL DISTURBED AREAS: SEE THE CONSTRUCTION LIMITS ON PLAN SHEETS C201 - C204.
- A17. IDENTIFICATION OF EXISTING VEGETATIVE COVER: THE SITE PRIMARILY CONSISTS MATURE TREES.
- A18. SOIL MAP INCLUDING DESCRIPTIONS AND LIMITATIONS: SEE THIS SHEET.
- A19. LOCATION, SIZE AND DIMENSIONS OF PROPOSED STORMWATER SYSTEMS: SEE PLAN SHEET C202 AND THE DETAILS ON THIS SHEET AND SHEET C203.
- A20. PLAN FOR ANY OFF-SITE CONSTRUCTION ACTIVITIES ASSOCIATED WITH THIS PROJECT: SEE SHEETS C201 - C203. AN EXISTING ACCESS DRIVEWAY WILL BE IMPROVED JUST WEST OF THE SITE.
- A21. LOCATIONS OF PROPOSED SOIL STOCKPILES, BORROW AND/OR DISPOSAL AREAS: SEE SHEET C203.
- A22. EXISTING SITE TOPOGRAPHY AT AN INTERVAL APPROPRIATE TO SHOW DETAILED DRAINAGE PATTERNS: SEE PLAN SHEET C202. EXISTING CONTOURS SHOWN ARE AT 1 FT INTERVALS.
- A23. PROPOSED FINAL TOPOGRAPHY AT AN INTERVAL APPROPRIATE TO SHOW DETAILED DRAINAGE PATTERNS: SEE PLAN SHEET C202. PROPOSED CONTOURS SHOWN ARE AT 1 FT INTERVALS.

SECTION B - CONSTRUCTION COMPONENT

- B1. DESCRIPTION OF POTENTIAL POLLUTANT SOURCES ASSOCIATED WITH THE CONSTRUCTION ACTIVITIES: SEE THE TABLE ENTITLED "POTENTIAL STORMWATER POLLUTANTS MATERIAL HANDLING AND SPILL PREVENTION" ON SHEET C203.
- B2. MOST ABUNDANT POLLUTANT CAUSED BY CONSTRUCTION WOULD BE SOIL SUSPENDED IN STORM WATER RUNOFF.
- B3. FUEL, OILS, AND OTHER FLUIDS ASSOCIATED WITH THE CONSTRUCTION EQUIPMENT COULD POSSIBLY RUNOFF AS WELL.
- B4. TRASH ASSOCIATED WITH HUMAN ACTIVITY, INCLUDING CONSTRUCTION MATERIALS.
- B5. SEQUENCE DESCRIBING STORMWATER QUALITY MEASURE IMPLEMENTATION RELATIVE TO LAND DISTURBING ACTIVITIES: THE FOLLOWING IS THE SEQUENCE FOR STORMWATER IMPLEMENTATION:
 1. THE CONTRACTOR SHALL ENSURE ALL PERSONNEL ON THE PROJECT ARE FAMILIAR WITH THE APPROPRIATE EROSION CONTROL MEASURES. THIS SHALL INCLUDE A VISUAL PRESENTATION OF SATISFACTORY AND UNSATISFACTORY EXAMPLES OF EROSION CONTROL FEATURES AND METHODS.
 2. CONTACT THE CITY OF BLOOMINGTON DEPT. OF PUBLIC WORKS PRIOR TO COMMENCING CONSTRUCTION.
 3. CONSTRUCT BOTH DETENTION PONDS WITH PERFORATED OUTLET RISERS AS TEMPORARY SEDIMENT STORAGE BASINS.
 4. REMOVE TREES AND VEGETATION WITHIN THE CONSTRUCTION LIMITS ONLY. STUMP TOP SOIL WHERE REQUIRED AND STOCKPILE AT LOCATIONS ABOVE SILT FENCE IF NEEDED. SEED WITH TEMPORARY SEED MIXTURE TYPE C. IMMEDIATELY MAINTAIN SILT FENCE DURING CONSTRUCTION AND KEEP CLEAR OF DEBRIS.
 5. PERFORM CONSTRUCTION ACTIVITIES AS SHOWN ON THE PLANS. DO NOT DISTURB TURF AREAS OUTSIDE OF CONSTRUCTION LIMITS SO THAT TURF ACTS AS A VEGETATIVE FILTER STRIP.
 6. PROTECT CONSTRUCTION STRUCTURES SHALL BE KEPT IN WORKING ORDER AND EROSION CONTROL COMPLETED EVERY RAIN EVENT.
 7. UPON COMPLETION OF CONSTRUCTION OF ALL IMPROVEMENTS REDISTRIBUTE TOP SOIL TO ALL PROPOSED GRASSED AREAS. MULCH SEED ALL DISTURBED AREAS WITH SEED MIXTURE OF ALL EARTHMOVING AND UNDERGROUND UTILITY WORK IN ACCORDANCE WITH INDOT SS-621 SEED MIXTURE TYPE U. FERTILIZE AND WATER SEEDED AREAS UNTIL MATURE TURF IS ESTABLISHED.
 8. REMOVE ALL TEMPORARY EROSION CONTROL MEASURES UPON THE ESTABLISHMENT OF MATURE GRASS TURF.
- B6. STABLE CONSTRUCTION ENTRANCE LOCATIONS AND SPECIFICATIONS: SEE SHEET C203 AND THE DETAIL ON SHEET C204.
- B7. SEDIMENT CONTROL MEASURES FOR SHEET FLOW AREAS: RIP RAP AND TURF REINFORCEMENT MATTING ARE SHOWN AT CONCENTRATED FLOW AREAS ON SHEET C203.
- B8. STORM SEWER INLET PROTECTION MEASURE LOCATION: DOES NOT APPLY.
- B9. RUNOFF CONTROL MEASURES: SEE SHEET C203.
- B10. STORMWATER OUTLET PROTECTION SPECIFICATIONS: METAL PIPE END SECTIONS, RIP RAP AND TURF REINFORCEMENT MATTING ARE TO BE USED WHERE SPECIFIED FOR OUTLET PROTECTION.
- B11. GRADE STABILIZATION STRUCTURE LOCATIONS AND SPECIFICATIONS: DOES NOT APPLY TO THIS PROJECT.
- B12. LOCATION, DIMENSIONS, SPECIFICATIONS AND CONSTRUCTION DETAILS OF EACH STORMWATER QUALITY MEASURE: SEE PLAN SHEETS C202, C203 AND THE DETAILS ON THIS SHEET AND SHEET C204.
- B13. TEMPORARY SURFACE STABILIZATION METHODS APPROPRIATE FOR EACH SEASON: SEE SHEET C202. TEMPORARY SEEDING SHOULD USE FERTILIZER

SECTION C - POST CONSTRUCTION COMPONENT

- C1. DESCRIPTION OF POLLUTANTS AND THEIR SOURCES ASSOCIATED WITH THE PROPOSED LAND USE: THE MAIN POST CONSTRUCTION POLLUTANTS WILL COME FROM THE PROPOSED EXISTING PARKING LOTS. THE POLLUTANTS MAY INCLUDE CAR FUEL, OIL, WASTEWATER, SUSPENDED SOLIDS, NITROGEN, PHOSPHORUS, COPPER, LEAD, AND ZINC.
- C2. SEQUENCE DESCRIBING STORM WATER QUALITY MEASURE IMPLEMENTATION RELATIVE TO LAND DISTURBING ACTIVITIES: WHEN ALL SITE WORK IS NEARLY COMPLETE AND BARE EARTH IS ESTABLISHED WITH GRASS INSTALL THE UNDERDRAIN COMPONENTS OF THE TWO BIO-RETENTION SWALE AND PLANT AS SPECIFIED. SEE SHEET C203.
- C3. DESCRIPTION OF PROPOSED POST CONSTRUCTION STORMWATER QUALITY MEASURES: SEE SHEET C203 FOR THE PROPOSED BIO-RETENTION SWALE LOCATION AS WELL AS THE DETAILS BEGINNING ON THIS SHEET. THE SITE WILL HAVE A NET REDUCTION OF YUKES IN ASPHALT/PAVING SURFACE (IMPERVIOUS SURFACE) FROM PREDEVELOPMENT TO POST DEVELOPMENT CONDITIONS. THE SITE WILL CONTAIN MORE GRASSED AREAS AND LANDSCAPING.
- C4. LOCATION, DIMENSIONS, SPECIFICATIONS AND CONSTRUCTION DETAILS OF EACH STORMWATER QUALITY MEASURE: SEE PLAN SHEET C203 AS WELL AS THE EROSION CONTROL DETAIL SHEETS BEGINNING ON THIS SHEET.
- C5. DESCRIPTION OF MAINTENANCE GUIDELINES FOR PROPOSED POST CONSTRUCTION WATER QUALITY MEASURES: SEE THE DETAIL FOR THE BIO-RETENTION SWALES ON THIS SHEET.

SECTION D - EROSION CONTROL COMPONENT

- D1. MONITORING AND MAINTENANCE GUIDELINES FOR EACH PROPOSED POLLUTION PREVENTION MEASURE: MONITORING AND MAINTENANCE OF ALL POLLUTION PREVENTION MEASURES SHALL BE THE RESPONSIBILITY OF THE CONTRACTOR. THE CONTRACTOR SHALL INSPECT ALL MEASURES AT LEAST ONCE A WEEK AND AFTER EACH STORM EVENT. THE CONTRACTOR SHALL PREPARE A WRITTEN REPORT FOR EACH INSPECTION NOTING CONDITIONS AND MAINTENANCE PROVIDED. A COPY OF EACH REPORT SHALL BE KEPT ON FILE AT THE PROJECT SITE. REFER TO EACH PREVENTION MEASURE DETAIL FOR CONSTRUCTION AND MAINTENANCE GUIDELINES.
- D2. EROSION & SEDIMENT CONTROLS SPECIFICATIONS FOR INDIVIDUAL BUILDING LOTS: THIS ITEM DOES NOT APPLY TO THIS PROJECT.



SOILS MAP

OC - Odrer silt loam, 6 to 12 percent slopes. This moderately sloping, deep, well drained soil is on narrow and broad convex ridges/tops of the uplands. Areas are generally elongated. They range from 3 to 200 acres and have a dominant size of about 40 acres. The available water capacity of this Odrer soil is high, and permeability is moderate. Runoff from cultivated areas is medium. The organic matter content of the surface layer is low. This soil is moderately limited for dwellings with and without basements because of slope. This soil is severely limited for local roads and streets by low strength. Limitations are moderate for septic tank absorption fields because of slope and moderate permeability.

HD - Hogestown silt loam, 12 to 18 percent slopes. This strongly sloping, deep, well drained soil is on side slopes of the uplands. Areas are generally long and narrow. They range from 3 to 200 acres and have a dominant size of about 20 acres. The available water capacity of the Hogestown soil is moderate, and permeability is moderate. Surface runoff from cultivated areas is rapid. The organic matter content of the surface layer is low. This soil is severely limited for building sites because of slope. This soil is severely limited for local roads and streets by low strength and slope. The limitation for septic tank absorption fields is severe because of slope.

- 1. MAINTENANCE NOTES:
 1. INSPECT THE POND AFTER EACH STORM EVENT TO ENSURE PROPER DRAINAGE.
 2. REMOVE AND PROPERLY DISPOSE OF SEDIMENT WHEN IT ACCUMULATES TO ONE HALF THE DESIGN VOLUME.
 3. PERIODICALLY CHECK THE UNDERDRAIN, EMERGENCY SPILLWAY, AND OUTLET FOR EROSION DAMAGE. PIPE SETTING, STORAGE, OR SLUMPING ALONG SOI OR MOUND BARREL: REPAIR IMMEDIATELY.
 4. REMOVE DEBRIS FROM THE POND, EMERGENCY SPILLWAY AND POOL AREA.
 5. CLEAN/REPLACE GRAVEL/SAND IN THE POND IF THE POOL DOES NOT DRAIN PROPERLY.

NOTE: THE POND POST-CONSTRUCTION UNDERDRAINS, BACKFILL, SAND, AND POND SEEDING SHALL BE COMPLETED AFTER THE SITE HAS BEEN STABILIZED WITH MATURE GRASS AND PLANTINGS.

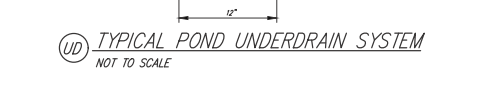

- 1. POINT CONSTRUCTION: UPON COMPLETION OF ALL SITE IMPROVEMENTS AND THE ESTABLISHMENT OF MATURE GRASS TURF AREAS THE SITE, REPLACE THE 6" RISER AND ELBOW WITH AN 8" TO 12" RISER AND INSTALL THE UNDERDRAIN SYSTEM DETAIL.
- 2. DURING CONSTRUCTION (ONLY):
 - 1-TEMPORARY OUTLET CONTROL STRUCTURE - 6" ADS IN-12 HOE PIPE. DO NOT INSTALL THE ARMORED SOIL UNDERDRAIN AND/OR PERFORATED RISER BEFORE UNTIL CONSTRUCTION IS COMPLETE AND THE CENTRE CISE IS PROTECTED WITH MATURE GRASS TURF.

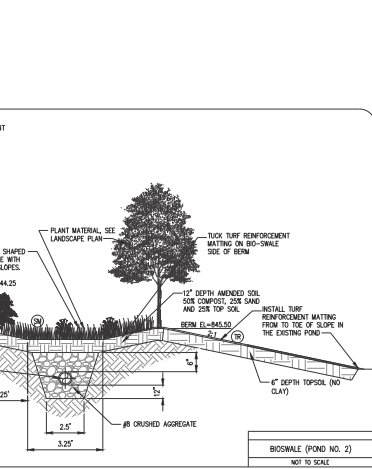
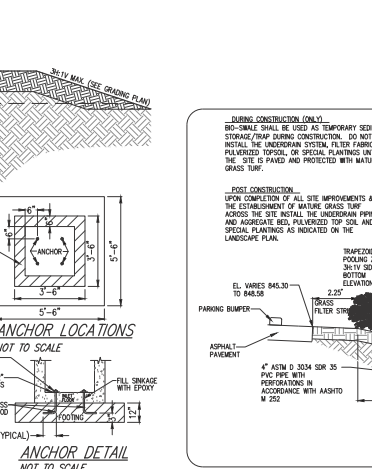
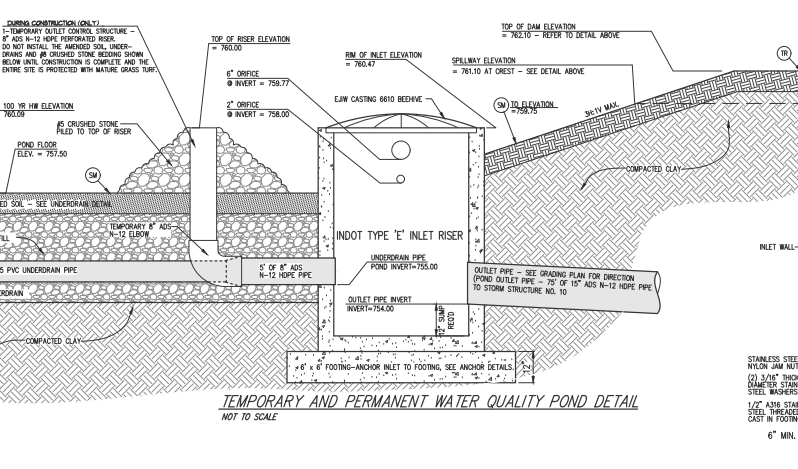

revisions:

ARCHITECTURE	PLANNING
CIVIL ENGINEERING	LANDSCAPE ARCHITECTURE
ENVIRONMENTAL ENGINEERING	SOILS
HYDROLOGIC	TRAIL
WATER QUALITY	WATER SUPPLY

BRUNNEN FANTO S. ASSOCIATES, INC.

2917 S. MOUNTAIN DRIVE
BLOOMINGTON, INDIANA 47403
(812) 383-2180
(812) 352-5600

certified by:

**PROPOSED
PROGRESS CONSTRUCTION &
DEVELOPMENT, INC. - S.I.M.P**

2917 S. MOUNTAIN DRIVE
BLOOMINGTON, INDIANA 47403

title: SWPPP NARRATIVE & DETAILS

designed by: JBT
drawn by: JBT
checked by: JSF
sheet no: C401
project no: 401542

MS PRACTICE 3.12 PERMANENT SEEDING

REQUIREMENTS Site and seeded preparation: Graded and line fertilizer applied. Plant species: Selected on the basis of soil type, soil pH, region of the state, time of year, planned use and how it will be seeded (see Exhibit 3.11-C).

APPLICATOR (ANSI 312-B, C and 6) Personally select all first grade areas (e.g., landscape benches, drainage swales, erosion control structures, etc.) as soon as completed and all areas where additional seed is not required for a period of more than a year.

- 1. SITE PREPARATION: ... 2. SEEDING: ... 3. MAINTENANCE: ...

Optimum seeding dates from May 1-May 10 and Aug 10-Sept. 30. Permanent seeding done between May 10 and Aug. 10 must be irrigated. As an alternative, use temporary seeding (Practice 3.11) until the preferred date for permanent seeding.

Exhibit 3.12-A. Permanent Seeding Recommendations. This table provides several seeding options. Additional seed species and mixtures are available commercially...

Table with columns: Seed species and mixtures, Rate per acre, Optimum soil pH. Includes rows for 2.Kentucky bluegrass, 3.Pernambuco ryegrass, etc.

Table with columns: LAMING AND HIGH MAINTENANCE AREAS. Includes rows for 1.Bulgarian, 2.Pernambuco ryegrass, etc.

Table with columns: CHANNELS AND AREAS OF CONCENTRATED FLOW. Includes rows for 1.Pernambuco ryegrass, 2.Kentucky bluegrass, etc.

* For best results, (a) ligumae seed should be broadcast; (b) seeding mixtures containing ligumae should preferably be sowing-seeded; (c) seeding mixtures containing ligumae should be sowing-seeded.

APPLICATOR An end of wheel compaction or area crop may be used with any of the above permanent seeding mixtures. If you do, be sure to seed during the fall seedling period, especially after Sept. 15, and at the following rates: spring 1.4 to 3.4 lbs./acre; wheel-no more than 1/2 lb./acre.

MAINTENANCE * Inspect periodically, especially after storm events, until the stand is successfully established. (Characteristics of a successful stand include vigorous dark green or bluish-green seedlings; uniform identity with parent plants; ligumae and grasses well inter-mixed; green leaves; and the perennial remaining green throughout the summer, at least at the start.)

PRACTICE 3.13 DORMANT AND FROST SEEDING

PURPOSES * To provide early germination and soil stabilization in the spring. * To stabilize seedlings until the end of the construction period. * To improve the visual aesthetics of the construction area. * To reduce erosion.

REQUIREMENTS Site and seeded preparation: Graded as needed, and line and fertilizer applied. Plant species: Selected on the basis of soil type, soil pH, region of the state, and planned use of the area (see Exhibits 3.11-B and 3.11-C).

APPLICATION (Exhibit 3.13-A) 1. DROVE THE AREA TO BE SEEDING: ... 2. SEEDING: ... 3. MAINTENANCE: ...

FOR DORMANT SEEDING Site and seeded preparation and mulching can be done months ahead of road seeding or at the existing ground cover is adequate, seeding can be directly into soil.

Table with columns: Seed species, Rate per acre, Optimum soil pH. Includes rows for 1.Pernambuco ryegrass, 2.Kentucky bluegrass, etc.

Table with columns: LAMING AND HIGH MAINTENANCE AREAS. Includes rows for 1.Bulgarian, 2.Pernambuco ryegrass, etc.

Table with columns: CHANNELS AND AREAS OF CONCENTRATED FLOW. Includes rows for 1.Pernambuco ryegrass, 2.Kentucky bluegrass, etc.

MAINTENANCE * Apply 200-300 lbs./acre of 12-12-12 equivalent fertilizer between Apr. 15 and May 10 or during periods of vigorous growth.

APPLICATION (Exhibit 3.13-B) 1. INITIAL PREPARATION: ... 2. SEEDING: ... 3. MAINTENANCE: ...

MAINTENANCE * Inspect periodically, especially after storm events, until the stand is successfully established. (Characteristics of a successful stand include vigorous dark green or bluish-green seedlings; uniform identity with parent plants; ligumae and grasses well inter-mixed; green leaves; and the perennial remaining green throughout the summer, at least at the start.)

PRACTICE 3.11 TEMPORARY SEEDING

REQUIREMENTS Site and seeded preparation: Graded and fertilizer applied. Plant species: Selected on the basis of soil type, soil pH, region of the state, and planned use of the area (see Exhibits 3.11-B and 3.11-C).

APPLICATION (Exhibit 3.11-A) 1. INITIAL PREPARATION: ... 2. SEEDING: ... 3. MAINTENANCE: ...

FOR FROST SEEDING Site and seeded preparation and mulching can be done months ahead of road seeding or at the existing ground cover is adequate, seeding can be directly into soil.

Table with columns: Seed species, Rate per acre, Optimum soil pH. Includes rows for 1.Pernambuco ryegrass, 2.Kentucky bluegrass, etc.

Table with columns: LAMING AND HIGH MAINTENANCE AREAS. Includes rows for 1.Bulgarian, 2.Pernambuco ryegrass, etc.

Table with columns: CHANNELS AND AREAS OF CONCENTRATED FLOW. Includes rows for 1.Pernambuco ryegrass, 2.Kentucky bluegrass, etc.

APPLICATION (Exhibit 3.11-B) 1. INITIAL PREPARATION: ... 2. SEEDING: ... 3. MAINTENANCE: ...

APPLICATION (Exhibit 3.11-C) 1. INITIAL PREPARATION: ... 2. SEEDING: ... 3. MAINTENANCE: ...

MAINTENANCE * Inspect periodically, especially after storm events, until the stand is successfully established. (Characteristics of a successful stand include vigorous dark green or bluish-green seedlings; uniform identity with parent plants; ligumae and grasses well inter-mixed; green leaves; and the perennial remaining green throughout the summer, at least at the start.)

PRACTICE 3.25 ROCK CHECK DAM

REQUIREMENTS Contributing drainage area: 2 acre maximum. Dam crest: 2 ft maximum height but at least 9 in. lower than the outer edge of natural ground elevation.

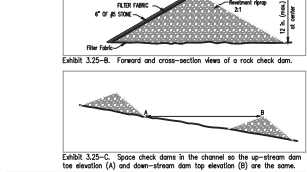
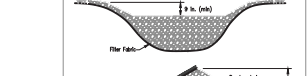

INSTALLATION 1. Excavate a cutoff trench into the ditch channel, and extend it a minimum of 18 in. beyond the abutments.

MAINTENANCE * Inspect check dams and the channel after each storm event, and repair and improve drainage after each event.

PRACTICE 3.01 TEMPORARY GRAVEL CONSTRUCTION ENTRANCE/EXIT PAD

PURPOSE * To provide a stable entrance/exit condition from the construction site. * To keep mud and sediment off public roads.

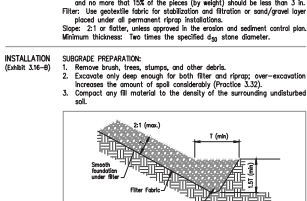

INSTALLATION 1. Remove brush, trees, stumps, and other debris. 2. Excavate the area enough for both filter and riprap, over-excavation increases the amount of soil potential (Practice 3.32).

REQUIREMENTS Rock: Hard, angular, and weather-resistant, having a specific gravity of about 1.65. Material: Well-graded stone, 3/8 to 1/2 inch larger than the specified size; however, the larger pieces should not exceed two times the specified size.

MAINTENANCE * Inspect periodically for displaced rock material, slumping, and erosion of abutment, especially downstream or downstream. (Properly designed and installed riprap usually requires very little maintenance if properly installed.)

TEMPORARY CONCRETE WASHOUT AREA

REQUIREMENTS Capacity: Temporary washout facilities shall be constructed above and below grade at the sites of the contractor. Temporary washout facilities shall be constructed and maintained in sufficient capacity and area to contain all liquid and concrete waste generated by construction activities.

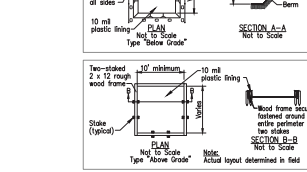
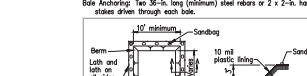

INSTALLATION 1. Excavate a cutoff trench into the ditch channel, and extend it a minimum of 18 in. beyond the abutments.

MAINTENANCE * Temporary concrete washout facilities shall be constructed as shown in the above details, and as described below. All temporary washout facilities shall have a minimum of 10 min. depth, 3' depth, and sufficient length to contain all liquid and concrete waste generated.

PRACTICE 3.16 RIPRAP

PURPOSE * To protect slopes, streambanks, channels, or similar areas subject to erosion by water.

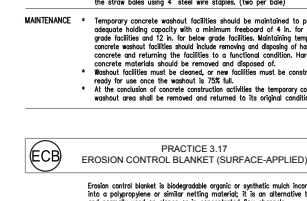

REQUIREMENTS Rock: Hard, angular, and weather-resistant, having a specific gravity of about 1.65. Material: Well-graded stone, 3/8 to 1/2 inch larger than the specified size; however, the larger pieces should not exceed two times the specified size.

INSTALLATION 1. Remove brush, trees, stumps, and other debris. 2. Excavate the area enough for both filter and riprap, over-excavation increases the amount of soil potential (Practice 3.32).

MAINTENANCE * Inspect periodically for displaced rock material, slumping, and erosion of abutment, especially downstream or downstream. (Properly designed and installed riprap usually requires very little maintenance if properly installed.)

PRACTICE 3.74 SILT FENCE (SEDIMENT FENCE)

PURPOSE * To retain sediment from mud, silt, and debris by reducing the velocity of sheet flow.

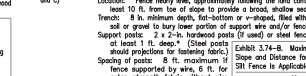

REQUIREMENTS Drainage Area: Limited to 1/4 acre per 100 ft. of fence; further restricted by slope (maximum length Exhibit 3.74-C).

INSTALLATION 1. Plan for the fence to be at least 10 ft. from the toe of the slope to provide a sediment storage area.

MAINTENANCE * Inspect the silt fence periodically and after each storm event. Remove sediment from the fence immediately.

PRACTICE 3.17 EROSION CONTROL BLANKET (SURFACE-APPLIED)

PURPOSE * To prevent erosion by protecting the soil from rainfall impact, outward water flow, concentrated runoff, or wind.

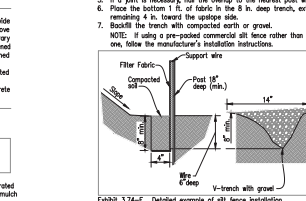

REQUIREMENTS Material: Fiber or organic (straw, mulch, wood, peat, etc.) or synthetic (polypropylene, polyethylene, or polypropylene).

INSTALLATION 1. Select the type and weight of erosion control blanket to fit the site conditions (e.g., slope, channel, flow velocity).

MAINTENANCE * Inspect the silt fence periodically and after each storm event. Remove sediment from the fence immediately.

PROPOSED PROGRESS CONSTRUCTION & DEVELOPMENT, INC. - SIMP 2017 S. MOUNTAIN DRIVE BLOOMINGTON, INDIANA 47403

For replacement matting, it is specified that the contractor shall ensure that the matting is installed in accordance with the following requirements:

- The matting shall be installed in a manner that allows for proper drainage of water.
- The matting shall be installed in a manner that allows for proper ventilation of the matting.
- The matting shall be installed in a manner that allows for proper protection of the matting.
- The matting shall be installed in a manner that allows for proper maintenance of the matting.

REQUIREMENTS: The contractor shall ensure that the matting is installed in accordance with the following requirements:

1. Install any protection needed to control erosion and runoff, such as (SWS 334-9)
2. Control the site as specified in the construction plan.
3. Prepare the matting, verify the matting, and seal the area.
4. Follow manufacturer's directions for the matting on the sealed area.
5. The matting shall be installed in a manner that allows for proper drainage of water.
6. The matting shall be installed in a manner that allows for proper ventilation of the matting.
7. The matting shall be installed in a manner that allows for proper protection of the matting.

WARNING: The contractor shall ensure that the matting is installed in accordance with the following requirements:

- The matting shall be installed in a manner that allows for proper drainage of water.
- The matting shall be installed in a manner that allows for proper ventilation of the matting.
- The matting shall be installed in a manner that allows for proper protection of the matting.
- The matting shall be installed in a manner that allows for proper maintenance of the matting.

Trade Name	Source	Characteristics	Storm Water	Removal Action
Material	Construction Material	Construction Material	Construction Material	Construction Material
Clearing	Storm Runoff	Storm Runoff	Storm Runoff	Storm Runoff
Soil	Soil	Soil	Soil	Soil
Asphalt	Asphalt	Asphalt	Asphalt	Asphalt
Concrete	Concrete	Concrete	Concrete	Concrete
Paint	Paint	Paint	Paint	Paint
Oil	Oil	Oil	Oil	Oil
Construction Equipment	Construction Equipment	Construction Equipment	Construction Equipment	Construction Equipment
Generator	Generator	Generator	Generator	Generator
Excavator	Excavator	Excavator	Excavator	Excavator
Tractor	Tractor	Tractor	Tractor	Tractor
Skid Steer Loader	Skid Steer Loader	Skid Steer Loader	Skid Steer Loader	Skid Steer Loader
Backhoe	Backhoe	Backhoe	Backhoe	Backhoe
Excavator	Excavator	Excavator	Excavator	Excavator
Generator	Generator	Generator	Generator	Generator
Excavator	Excavator	Excavator	Excavator	Excavator
Tractor	Tractor	Tractor	Tractor	Tractor
Skid Steer Loader	Skid Steer Loader	Skid Steer Loader	Skid Steer Loader	Skid Steer Loader
Backhoe	Backhoe	Backhoe	Backhoe	Backhoe
Excavator	Excavator	Excavator	Excavator	Excavator
Generator	Generator	Generator	Generator	Generator
Excavator	Excavator	Excavator	Excavator	Excavator
Tractor	Tractor	Tractor	Tractor	Tractor
Skid Steer Loader	Skid Steer Loader	Skid Steer Loader	Skid Steer Loader	Skid Steer Loader
Backhoe	Backhoe	Backhoe	Backhoe	Backhoe
Excavator	Excavator	Excavator	Excavator	Excavator

DESIGNED BY: JBT
 CHECKED BY: JBT
 PROJECT NO.: 401542

PROPOSED
 PROGRESS CONSTRUCTION &
 DEVELOPMENT, INC. - SIMP
 2917 S. MCINTIRE DRIVE
 BLOOMINGTON, INDIANA 47403

ARCHITECTURE
 CIVIL ENGINEERING
 PLANNING
 BYNUM FANYO & ASSOCIATES, INC.
 528 North Walnut Street
 (812) 332-8030
 Bloomington, Indiana
 (812) 339-2990 (Fax)

2119

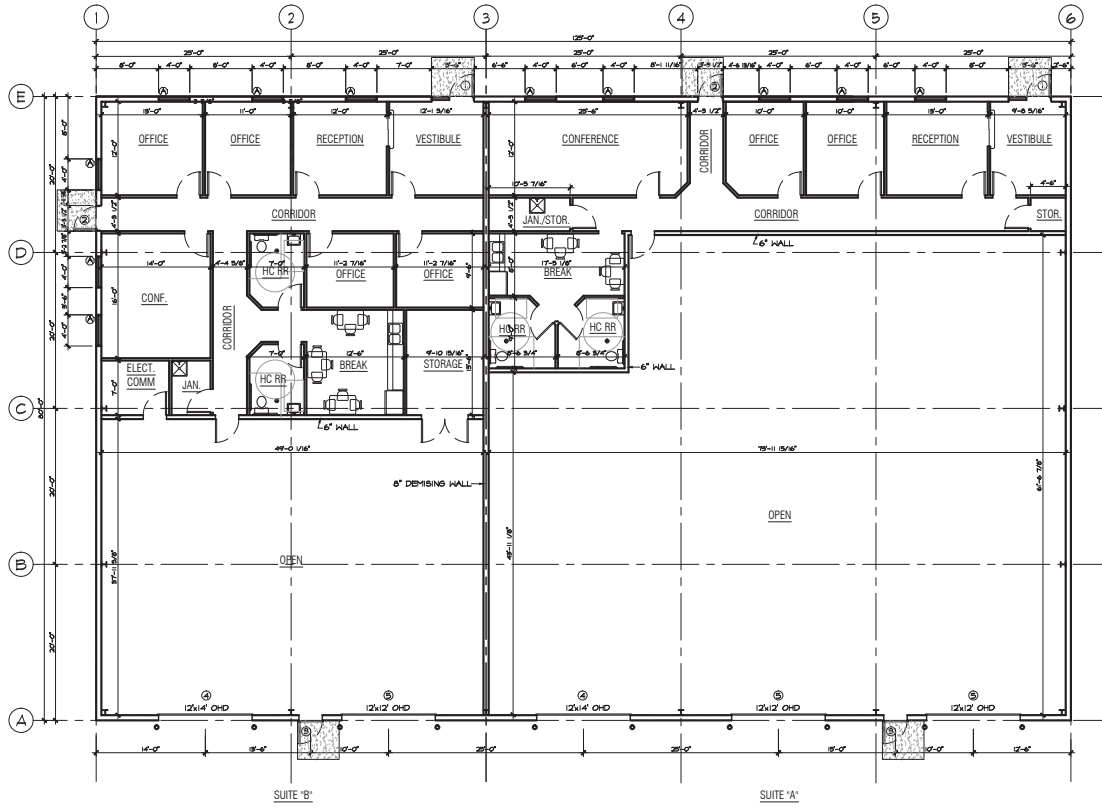

FLOOR PLAN
 SCALE: 1/8" = 1'-0"



TAPP ROAD FACILITY
 Bloomington, Indiana 47403

PRELIMINARY DOCUMENT

Stephen C. Hoffman - Engineer
 IN # PE600188

DESIGNED BY	JHD
CHECKED BY	
DATE	
SHEET TITLE	

FLOOR PLAN

PROJECT NO.	SHEET NUMBER
0476	1
DATE	
13 Sept. 18	

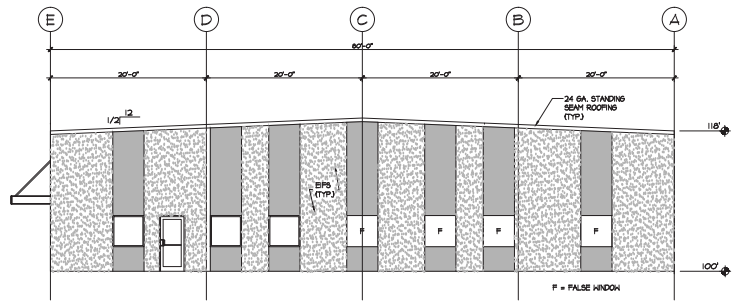

SOUTH ELEVATION
 SCALE: 1/8" = 1'-0"

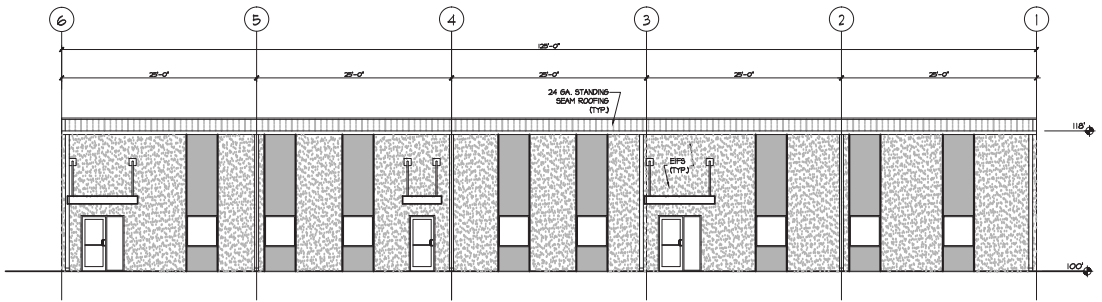

SOUTH ELEVATION
 SCALE: 1/8" = 1'-0"

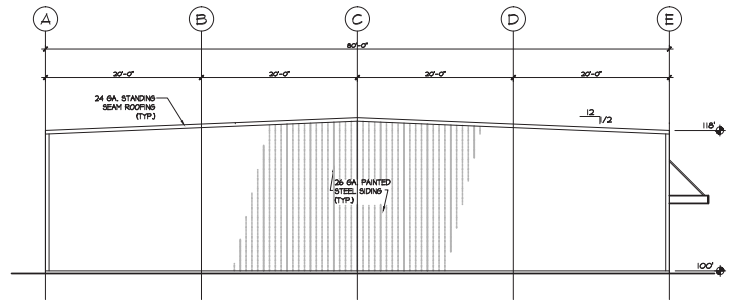

NORTH ELEVATION
 SCALE: 1/8" = 1'-0"

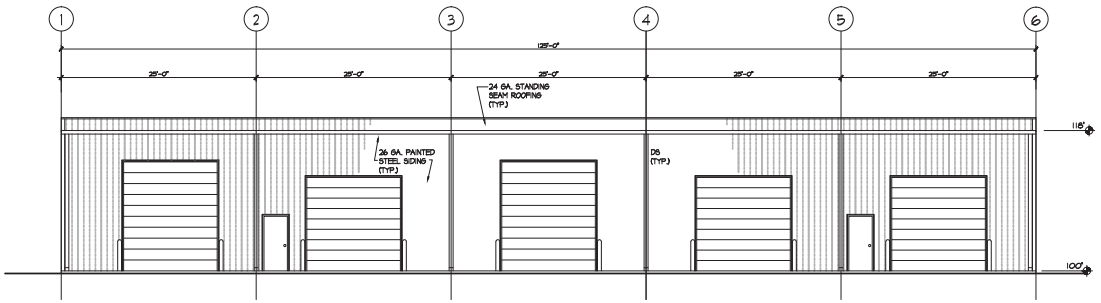

EAST ELEVATION
 SCALE: 1/8" = 1'-0"

TAPP ROAD FACILITY
 Bloomington, Indiana 47403

PRELIMINARY DOCUMENT

PROJECT: TAPP ROAD

Stephen C. Hoffman - Engineer
 IN # PE600188

DESIGNED BY: JCH

REVISED:

- ▲
- ▲
- ▲
- ▲

SHEET TITLE

ELEVATIONS

PROJECT NO.	SHEET NUMBER
DATE	2
13 Sept. 18	