

**Bloomington Historic Preservation Commission Showers City Hall  
McCloskey Room, Thursday August 8, 2019, 5:00 P.M. AGENDA**

**I. CALL TO ORDER**

**II. ROLL CALL**

**III. APPROVAL OF MINUTES**

A. July 25, 2019 Minutes

**IV. CERTIFICATES OF APPROPRIATENESS**

**Staff Review**

**A. COA 19-46**

326 S. Fairview Street (Greater Prospect Hill Historic District)

Petitioner: Janis Price

*Remove chimney below roof deck level.*

**Commission Review**

**A. COA 19-44**

346 S. Buckner Street (Greater Prospect Hill Historic District)

Petitioner: Chris Valliant

*Full demolition of primary structure on the lot.*

**B. COA 19-45**

324 S. Rogers Street (Prospect Hill Historic District)

Petitioner: Jaime Galvan

*Two story addition to the rear of the home. Addition of decorative shingles and round vents to east and south facing gables. Renovate shed structure.*

**C. COA 19-47**

1113 E. 1st Street (Elm Heights Historic District)

Petitioner: Emily Black

*Replace steel casement window on front of the home with Pella Lifestyle casement window.*

**V. DEMOLITION DELAY**

**Staff Review**

**A. Demo-Delay 19-12**

1301 S. Washington Street

Petitioner: Tucker Jarrol (Loren Wood Builders)

*Partial demolition: Creation of a new window or door opening.*

**VI. NEW BUSINESS**

**A. Changes to Demolition Delay in New UDO**

**VII. OLD BUSINESS**

**B. Historic Designation Review Proceedings (523 W. 7th)**

**C. Demolition Delay 19-12 (521 N. Dunn)**

**VIII. COMMISSIONER COMMENTS**

**IX. PUBLIC COMMENTS**

**X. ANNOUNCEMENTS**

**XI. ADJOURNMENT**

*Auxiliary aids for people with disabilities are available upon request with adequate notice. Please call 812-349-3429 or email, [human.rights@bloomington.in.gov](mailto:human.rights@bloomington.in.gov).*

Next meeting date is August 22, 2019 at 5:00 P.M. in the McCloskey Room. **Posted:** 8/1/2019

# Bloomington Historic Preservation Commission

Showers City Hall, McCloskey Room

Thursday July 25, 2019

## MINUTES

Meeting was called to order by Jeff Goldin @ 5:00pm

### ROLL CALL

#### Present

Doug Bruce  
Susan Dyer  
Jeff Goldin  
Deb Hutton  
Lee Sandweiss  
John Saunders  
Chris Sturbaum (5:02)

#### Absent

Leslie Abshier  
Sam DeSollar  
Ernesto Casteneda  
Duncan Campbell  
Jenny Southern  
Derek Richey

#### Staff

Eric Sader, HAND  
Angela Van Rooy, HAND  
Mike Rouker, Legal

#### Guests

Joe La Mantia, COA 19-42 Petitioner  
Jeannine Butler  
Judy Fulford

### APPROVAL OF MINUTES

**John Saunders** made a motion to approve July 11<sup>th</sup>, 2019 Minutes, **Deb Hutton** seconded.  
**Motion carried 4-0-2 (Yes-No-Abstain)**

### CERTIFICATES OF APPROPRIATENESS

#### Commission Review

##### A. COA 19-42

820 W. Howe Street (Greater Prospect Hill Historic District)  
Petitioner: Joe La Mantia  
*Removal of historic sidewalk in front of 820 W. Howe and 401 S. Euclid.*

**Eric Sader** gave presentation. See packet for details.

#### Commissioner Questions

**Chris Sturbaum** asked whether the neighbor's sidewalk is also included in this petition, as that area is in similar condition. **Eric Sader** confirmed that 820 W Howe and 401 S Euclid are both included. **Chris Sturbaum** stated that this is a critical precedent setting action by the HPC because in the past the HPC protected the sidewalks so that nobody could repair them. When the City did repairs it was expensive and they decayed rapidly (~10 years). Considering the condition of many

of the stones in this 80 year old sidewalk, the best strategy for HPC is to let go of the stones that are beyond repair and focus on saving that portion which can be saved and repaired.

**Deb Hutton** said on 13<sup>th</sup> St between Indiana Ave and Woodward Ave. the sidewalk is similar to the one in this petition. IU is now building new sidewalks in that area and using stamped, poured concrete.

#### Commissioner Comments

**Chris Sturbaum** stated that it is important and sensible to know when to let something go and when to fix it. That makes HPC be more reasonable and allows continued cooperation with Public Works. This also makes the sidewalks safer for the public.

**John Saunders** stated he appreciates saving the date-stamped portion of the sidewalk.

**Deb Hutton** asked if there could be a plaque added to the retaining wall stating the history of the 1939 sidewalk. Maybe it could become part of an historic tour.

**Doug Bruce** stated that he appreciates **Chris Sturbaum's** comments about the balance between saving structures and letting them go. This is a good compromise because public safety is an issue. HPC is setting up a good precedent for future historic sidewalk repair and preservation.

**Lee Sandweiss** agrees with others' comments.

**Susan Dyer** agreed that retention of the 9-foot stretch is a good compromise, and that the current sidewalk is a public safety issue.

**Jeff Goldin** stated that the petition represents a great balance between historic preservation, public safety, and realistic cost for homeowners. It's great to be saving as many stones as possible so they are available for others to use to fix sidewalks on their properties.

**Chris Sturbaum** stated that the City has program to share costs with homeowners as an incentive to make sidewalk repairs. **Eric Sader** clarified that this program is currently only available in designated neighborhoods based on low-income census tracts.

**John Saunders** made a motion to approve COA 19-42, **Susan Dyer** seconded. Motion carried **7-0-0 (Yes-No-Abstain)**.

## **DEMOLITION DELAY**

### Commission Review

#### **A. Demo-Delay 19-12**

521 N. Dunn Street

Petitioner: David Howard

*Full demolition of the structure*

**Eric Sader** gave presentation. See packet for details.

**Jeannine Butler** asked HPC to reject releasing this demolition permit. McCalla school is across the street. This was a neighborhood for African American workers, before they moved to the westside. May have been an African American fraternity in this neighborhood, as well as boarding houses. Demolition of this house would destroy the integrity of a core neighborhood. It would start a trend for high rise apartments to be built in this area. Preserve this house to stop incursion of multi-story apartments.

### Commissioner Questions

**Chris Sturbaum** asked if this area this zoned multifamily (**Eric Sader** confirmed that zoning is *residential, multi-family*), as the proposed UDO would turn all multi-family into high-density.

**Judy Fulford** lived in neighborhood for over 30 years, and expressed her concern that demolition of this house would begin the process of destroying the character of neighborhood. What replaces this house matters. There is a disconnect between what is torn down and what gets built in its place.

**Eric Sader** reminded everyone that HPC is only focusing on the designation of this particular property, not what might replace it.

**Jeannine Butler** reiterated her request that HPC not release the Demolition Delay, and

asked Conor to conduct an “in-depth survey” to determine whether this house is worthy of historic designation.

**Eric Sader** cautioned that preserving this property on the basis of neighborhood character rather than benefits of this particular house may set a precedent for how other properties in this neighborhood might be handled in the future.

#### Commissioner Comments

**Chris Sturbaum** noted that a *contributing structure* means that it has value in being a part of the other houses, and what happens in that area is relevant to the decision about this house. Residential/multi-family zoning (5-unrelated individuals) was introduced to moderate neighborhoods that were too dense to down zone to single-family. The proposed zoning change is to do away with Residential/multi-family and make is residential high-density. This is a radical change, if it goes through anything could be built on this property. Advocated tabling until next meeting.

**John Saunders** said it’s important to retain the character of the neighborhood, and would like to see this property protected.

**Deb Hutton** advocated tabling until next meeting, and asked that Conor conduct more research.

**Doug Bruce** concurred. Jeannine’s comments are important, and if there might be more information on the house, HPC should delay a decision in order for Conor to conduct more research.

**Lee Sandweiss** agreed that HPC should not release the demo delay at this time, and asked if the area could be designated as historic. **Jeff Goldin** clarified that HPC cannot unilaterally designate historic districts. **Chris Sturbaum** said HPC can recommend designations to the City Council, but it’s “messy”. **Lee Sandweiss** suggested that tabling until next meeting would allow Advisory members (who were absent) to contribute what they know about the neighborhood.

**Jeff Goldin** stated that HPC can start designation process, which would protect the property from today, or HPC can table until the next meeting to allow Conor to conduct further research. **Doug Bruce** advocated tabling because there is no precedent to begin formal designation with a staff report being what it is.

**John Saunders** made a motion to table Demo Delay 19-12, **Chris Sturbaum** seconded. **Motion carried 7-0-0 (Yes-No-Abstain).**

#### **B. Demo-Delay 19-13**

801 S. Walnut Street

Petitioner: David Howard

*Full demolition of the structure*

**Eric Sader** gave presentation. See packet for details.

Commissioners reviewed the street view map to get a sense of the surrounding area. Zoning is Commercial Arterial, one of the least restrictive.

#### Commissioner Questions

**Chris Sturbaum** asked if the petitioner could explore moving the house.

#### Commissioner Comments

**Chris Sturbaum** stated that this is an example of “strayed from the herd house”

**John Saunders** said that the condition of the inside of the house is not good.

**Doug Bruce** said this is an example of how HPC looks at “contributing” structures. There is nothing to contribute to in this area, so there is no basis to designate.

**Lee Sandweiss** agreed that this is the last house of its kind in the area. HPC should let it go.

**Jeff Goldin** stated that this is a difficult area, and redevelopment could be a positive thing. He sees no reason to save it. Could someone reach out to petitioner to see if he



would be willing to donate it?

**Chris Sturbaum** added that this is a good example of how Demolition Delay works. Some properties are not worth saving, but Demo Delay gives HPC one more chance to think about it.

**John Saunders** made a motion to release Demo-Delay 19-13, **Chris Sturbaum** seconded. **Motion carried 7-0-0 (Yes-No-Abstain).**

## **OLD BUSINESS**

### **Update on “523 W. 7th” historic designation review proceedings**

Conor will give an in depth update on the status of 523 W. 7th at the next HPC meeting.

## **COMMISSIONER COMMENTS**

**Deb Hutton** asked how HPC can ask owner of 523 W. 7<sup>th</sup> to preserve the central passage house if HPC deals only with the outside of structures. **Jeff Goldin** clarified that HPC is only asking that the owner retain the exterior, and can only hope they save the inside. HPC can only advise.

**Doug Bruce** invited everyone to come to the Indianapolis Speedway next week Th/F/S/S to see him race his 1972 Formula 4.

**Jeff Goldin** expressed his appreciation for Jeannine Butler’s presence at the meeting. She served on the HPC for many years and he misses her experience.

## **PUBLIC COMMENTS**

**Jeannine Butler** stated that when she was on the HPC there was great effort to save every possible property, and in the long run it has been a positive for the City. She is happy to know that the current HPC has released only a small number of Demo Delays.

## **ADJOURNMENT**

Meeting was adjourned by **Jeff Goldin** @ 5:52 pm.

**END OF MINUTES**

**COA: 19-46**  
**Staff Decision**

Address: 326 S. Fairview Street  
Petitioner: Janis Price  
Parcel #: 53-08-05-102-004.000-009

**Rating:** Contributing

**Structure;** Gabled Ell c. 1910



**Background:** A slightly altered Gable-Ell style home located in the Greater Prospect Hill Historic District. The chimney is not structurally stable and has been leaking.

**Request:** Removal of brick chimney below roof deck level.

**Guidelines:** Greater Prospect Hill Historic District Design Guidelines, (See next page)

**Staff Decision:** Staff approved COA 19-40 for the following reasons:

1. According to the Greater Prospect Hill Historic District, “Chimneys may be removed unless they are an outstanding characteristic of the property.” Staff does not find that the chimney qualifies as an “outstanding” feature.
2. Many of the homes in the vicinity have had their chimneys removed.
3. There is precedent for staff approved chimney removal in Greater Prospect Hill:

(COA 18-82 & 18-85)

## B. CHANGES TO THE PUBLIC WAY FAÇADE

*The following Public Way Façade guidelines are new and were not found in the 2008 Prospect Hill Conservation District Guidelines. The addition of these guidelines is necessary to address the elevation of the Prospect Hill Conservation District to a Historic District.*

Changes to the public way façade shall be reviewed for COA (Certificate of Appropriateness) approval by HAND (Housing and Neighborhood Development) staff. Either the homeowner or HAND staff may appeal to the BHPC (Bloomington Historic Preservation Commission) for further review.

The following guidelines relate to the above actions and they are enforceable by the BHPC.

**Definition:** The **public way façade** refers to the side of the house that faces the street to which the house has a public postal address. In the case of corner lots, both the postal street as well as the cross street are considered public way façades.

The intent of the GPHHD (Greater Prospect Hill Historic District) is to encourage homeowner improvements and maintenance of properties that are compatible with the original character of the homes.

Existing architectural details (specifically original historic elements) for windows, porches, doors and eaves on the public way façade shall be retained or replaced in the same style or in a design appropriate to the character of the house or streetscape.

1. Retain the proportions of all original openings (e.g., doors, windows, etc.). Replacement of windows and doors determined to be original should duplicate the original in size and scale in ways that do not visually impact the public way façade of the house and continue to reflect the period of the house. (For issues regarding accessibility, see Section VII, Safety and Access, found on page 27.)
2. Retain siding determined to be original. If using alternative materials as siding, the homeowner should use material that is compatible with the original material's character. For example, horizontal fiber cement siding with identical lap reveal is appropriate. When hardboard or concrete board siding is used to simulate wood clapboard siding, it should reflect the general directional and dimensional characteristics found historically in the neighborhood. No products imitating the "grain" of wood should be used. Brick, limestone, clapboard, cement board, wood, shingles, stucco are recommended materials.
3. Vinyl and aluminum siding may be used, although care should be taken during installation to retain original materials where they exist (e.g., door and window trim and underlying siding if it is original).

Retain historical character-defining architectural features and detailing, and retain detailing on the public way façade such as brackets, cornices, dormer windows, and gable end shingles. (See Section C, Removal of Original Materials, found on page 26).

Prioritize the retention of the roof's original shape as viewed from the public way façade.  
**Chimneys may be removed unless they are an outstanding characteristic of the property.**

APPLICATION FORM  
CERTIFICATE OF APPROPRIATENESS

RECEIVED  
JUL 26 2019

BY: .....

Case Number: 19-46

Date Filed: 7-26-19

Scheduled for Hearing: 8-8-19

\*\*\*\*\*

Address of Historic Property: 326 S. Fairview St., Bloomington 47403

Petitioner's Name: Janis E. Price

Petitioner's Address: 326 S. Fairview St., Bloomington, IN. 47403

Phone Number/e-mail: janis3777@aht.net ; 818.300.3475

Owner's Name: same as above

Owner's Address: " " "

Phone Number/e-mail: " " "

Instructions to Petitioners

The petitioner must attend a preliminary meeting with staff of the Department of Housing and Neighborhood Development during which the petitioner will be advised as to the appropriateness of the request and the process of obtaining a Certificate of Appropriateness. The petitioner must file a "complete application" with Housing and Neighborhood Department Staff no later than seven days before a scheduled regular meeting. The Historic Preservation Commission meets the second Thursday of each month at 5:00 P.M. in the McCloskey Room. The petitioner or his designee must attend the scheduled meeting in order to answer any questions or supply supporting material. You will be notified of the Commission's decision and a Certificate of Appropriateness will be issued to you. Copies of the Certificate must accompany any building permit application subsequently filed for the work described. If you feel uncertain of the merits of your petition, you also have the right to attend a preliminary hearing, which will allow you to discuss the proposal with the Commission before the hearing during which action is taken. Action on a filing must occur within thirty days of the filing date, unless a preliminary hearing is requested.



Please respond to the following questions and attach additional pages for photographs, drawings, surveys as requested.

A "Complete Application" consists of the following: Parcel No.: 53.08.05.102.004.000.009

1. A legal description of the lot. 015.47660-00 Prospect Hill Lot 39  
Section: 05, Township: 08N, Lot #: 39

2. A description of the nature of the proposed modifications or new construction:

Remove chimney below roof deck level.  
After inspection of chimney, it was determined  
to be unsafe condition and beyond reasonable repair.

3. A description of the materials used.

1 x 8 pine plank board  
2 x 8 pine (ridge beam)  
Asphalt shingle

4. Attach a drawing or provide a picture of the proposed modifications. You may use manufacturer's brochures if appropriate.

5. Include a scaled drawing, survey or geographic information system map showing the footprint of the existing structure and adjacent thoroughfares, Geographic Information System maps may be provided by staff if requested. Show this document to Planning Department Staff in order to ascertain whether variances or zoning actions are required.

6. Affix at least three photographs showing the existing full facade at each street frontage and the area of modification. If this petition is a proposal for construction of an entirely new structure or accessory building, include photographs of adjacent properties taken from the street exposure.

\*\*\*\*\*

If this application is part of a further submittal to the Board of Zoning Appeals for a Conditional Use or development standard variance, please describe the use proposed and modification to the property which will result.













**COA: 19-44**

Address: 346 S. Buckner Street

Petitioner: Chris Valliant

Parcel #: 53-08-05-110-018.000-009

**Rating:** Non-Contributing

**Structure;** Pyramid Roof Cottage

c. 1915



**Background:** A heavily altered Pyramid roof cottage style home located in the Greater Prospect Hill Historic District. The exterior of the home is severely deteriorated with open holes in the roof.

**Request:** Full demolition.

**Guidelines:** Greater Prospect Hill Historic District Design Guidelines, (See next page)

**Recommendation:** Staff recommends approval of COA 19-40 for the following reasons:

1. Staff finds that the structure meets Criteria #2 for demolition as found in the Greater Prospect Hill Design Guidelines because it is Non-Contributing: “The historic or architectural significance of the structure is such that, upon further consideration by the Commission, it does not contribute to the historic character of the district.
2. The structure is in an advanced state of disrepair and would likely be found to be a substantial threat to public safety if investigated by the proper authorities.

### III. GUIDELINES FOR DEMOLITION

*The following Demolition Guidelines were copied directly from the 2008 Prospect Hill Conservation District Guidelines that were approved by over 51% of the neighbors who voted. They have not been modified in any way.*

#### STANDARDS FOR DEMOLITION

A Certificate of Appropriateness must be issued by the Bloomington Historic Preservation Commission before a demolition permit is issued by other agencies of the city and work is begun on the demolition of any building in the Prospect Hill Conservation District. This section explains the type of work considered in this plan to be demolition as well as the criteria to be used when reviewing applications for Certificates of Appropriateness that include demolition.

#### SUBJECT TO REVIEW AND APPROVAL:

1. **Demolition of primary structures within the boundaries of the Greater Prospect Hill Historic District.**
2. **Demolition of contributing accessory buildings within the boundaries of the Greater Prospect Hill Historic District.**

The following guidelines relate to the above actions and they are enforceable by the BHPC.

Definition: **Demolition** shall be defined as the complete or substantial removal of any historic structure which is located within a historic district. This specifically excludes partial demolition as defined by Title 8 “Historic Preservation and Protection”

([https://bloomington.in.gov/code/level2/TIT8HIPRPR\\_CH8.12DEPUSA.html](https://bloomington.in.gov/code/level2/TIT8HIPRPR_CH8.12DEPUSA.html)).

#### CRITERIA FOR DEMOLITION

When considering a proposal for demolition, the BHPC shall consider the following criteria for demolition as guidelines for determining appropriate action. The HPC shall approve a Certificate of Appropriateness or Authorization for demolition as defined in this chapter only if it finds one or more of the following:

1. The structure poses an immediate and substantial threat to public safety as interpreted from the state of deterioration, disrepair, and structural stability of the structure. The condition of the building resulting from neglect shall not be considered grounds for demolition.
2. **The historic or architectural significance of the structure is such that, upon further consideration by the Commission, it does not contribute to the historic character of the district.**
3. The demolition is necessary to allow development which, in the Commission’s opinion, is of greater significance to the preservation of the district than is retention of the structure, or portion thereof, for which demolition is sought.
4. The structure or property cannot be put to any reasonable economically beneficial use without approval of demolition.
5. The structure is accidentally damaged by storm, fire or flood. In this case, it may be rebuilt to its former configuration and materials without regard to these guidelines if work is commenced within 6 months.

APPLICATION FORM  
CERTIFICATE OF APPROPRIATENESS

Case Number: 19-414  
Date Filed: 7-26-19  
Scheduled for Hearing: 8-8-19

\*\*\*\*\*

Address of Historic Property: 346 S. Buckner  
Petitioner's Name: Chris Valliant  
Petitioner's Address: 2591 S. Garrison Chapel Rd  
Phone Number/e-mail: 812-320-2139  
Owner's Name: Same as above  
Owner's Address: \_\_\_\_\_  
Phone Number/e-mail: \_\_\_\_\_

Instructions to Petitioners

The petitioner must attend a preliminary meeting with staff of the Department of Housing and Neighborhood Development during which the petitioner will be advised as to the appropriateness of the request and the process of obtaining a Certificate of Appropriateness. The petitioner must file a "complete application" with Housing and Neighborhood Department Staff no later than seven days before a scheduled regular meeting. The Historic Preservation Commission meets the second Thursday of each month at 5:00 P.M. in the McCloskey Room. The petitioner or his designee must attend the scheduled meeting in order to answer any questions or supply supporting material. You will be notified of the Commission's decision and a Certificate of Appropriateness will be issued to you. Copies of the Certificate must accompany any building permit application subsequently filed for the work described. If you feel uncertain of the merits of your petition, you also have the right to attend a preliminary hearing, which will allow you to discuss the proposal with the Commission before the hearing during which action is taken. Action on a filing must occur within thirty days of the filing date, unless a preliminary hearing is requested.

Please respond to the following questions and attach additional pages for photographs, drawings, surveys as requested.

A "Complete Application" consists of the following:

1. A legal description of the lot. 015-07160-00 Prospect Park 3rd Lot 15

2. A description of the nature of the proposed modifications or new construction:  
Full demolition of structure

House has bene left for 20 years falling into disrepair. The floors and ceilings are both falling in.

3. A description of the materials used.

4. Attach a drawing or provide a picture of the proposed modifications. You may use manufacturer's brochures if appropriate.

5. Include a scaled drawing, survey or geographic information system map showing the footprint of the existing structure and adjacent thoroughfares, Geographic Information System maps may be provided by staff if requested. Show this document to Planning Department Staff in order to ascertain whether variances or zoning actions are required.

6. Affix at least three photographs showing the existing full facade at each street frontage and the area of modification. If this petition is a proposal for construction of an entirely new structure or accessory building, include photographs of adjacent properties taken from the street exposure.

\*\*\*\*\*

If this application is part of a further submittal to the Board of Zoning Appeals for a Conditional Use or development standard variance, please describe the use proposed and modification to the property which will result.



**COA: 19-45**

Address: 324 S. Rogers Street

Petitioner: Jaime Galvan

Parcel #: 53-08-05-102-039.000-009

**Rating:** Contributing

**Structure;** Free Classic Queen Anne c. 1890



**Background:** This home is one of five in Prospect Hill Historic District designed by Bloomington architect John Nichols. The Free Classic style was favored by Nichols and is prevalent in many of the buildings he designed.

**Request:** Major renovations. (See packet for specifications and materials.)

1. Add decorative roof shingles and round venting windows to the east and west facing gables.
2. Reconstruct rear addition by expanding the footprint to the south and west and adding a second level.
3. Add door access to level 2 of the addition and add deck railings which will meet code height.
4. Add door access and build balcony and deck railing on level 3 of the north elevation.
5. Addition of shed dormer and balcony on level 3.
6. Rehabilitation of shed. Add foundation to shed and straighten and stabilize walls. Update and replace windows and doors, and replace siding where required.

# COA: 19-45

**Guidelines:** Immediately following staff report in the Packet.

1. Prospect Hill Historic District Design Guidelines, pg. 13, 21, 22
2. Secretary of the Interiors Standards for Rehabilitation

**Recommendation: Staff recommends conditioned approval of COA 19-45**

Staff Recommends **Approval** of the following items:

1. *The use of decorative shingles on the gable ends.* This is a visual feature commonly found on Victorian style homes and this home may have featured decorative shingles in the past before it was sided with aluminum.
2. *Reconstruct rear addition by expanding the footprint to the south and west and adding a second level.* The rear addition will be still subordinate to the original structure in size, height, and mass. The siding, windows, foundation, and color are compatible to the original structure. Staff recommends that a visual break be used to help delineate old from new and that the applicant should consider pairing the windows on the addition in a fashion similar to the windows on the east and south elevations of the original structure.
3. *Rehabilitation of the shed.* The shed is not original to the home. It is not on the 1927 Sanborn but it does appear on a 1947 aerial photograph. Staff finds no reason to object to the applicant's proposed rehabilitation of this structure.

Staff Recommends **Denial** of the following items:

1. *Add door access and build balcony and deck railing on level 3 of north elevation.* This would lead to the destruction of original materials and dramatically alter the gable end of the north façade. This is in conflict with the Secretary of the Interior Standards for Rehabilitation #2, “The historic character of a property shall be retained and preserved. The removal of historic materials or alterations of features and spaces that characterize a property shall be avoided.
2. *Addition of shed dormer and balcony on level 3.* A shed dormers is not a Queen Anne architectural feature. This conflicts with Secretary of the Interior Standards for Rehabilitation #3 “Changes that create a false sense of historical development, such as adding conjectural features or architectural elements from other buildings, shall not be undertaken”.
3. *Add door access to level 2 of the addition, create a balcony space, and add deck railings.* Staff finds no precedent in the district for a balcony running the full length of a wall.

# **GUIDELINES FOR EXISTING BUILDINGS**

## **BUILDING MATERIALS**

Paint color and exterior finish materials give a building distinct texture, presentation and character. Alterations to buildings and structures should take into consideration the careful balance that is achieved through selection of building materials.

### **WOOD**

#### **Appropriate**

Retain and restore original exterior wood siding materials (typically clapboard) through repair, cleaning, painting, and routine maintenance. If original architectural details and trim features are deteriorated beyond repair, they should be replaced with components of the same material and design.

#### ***Inappropriate***

*Avoid application of siding materials not consistent with the character or style of the building, or materials that were unavailable at the time the building was constructed.*

### ***FOR YOUR INFORMATION***

*Artificial sidings such as artificial stone or brick, asphalt shingle and brick, plywood, particle board, hard board and aluminum or vinyl siding have been documented to cause and cover up serious, costly and often irreparable damage to buildings. (See also synthetic siding, pages 26-27.)*

### **MASONRY**

#### **Appropriate**

Maintain masonry by proper tuckpointing and appropriate cleaning. Tuckpoint mortar joints with mortar that duplicates the original in strength, composition, color, texture, joint size, method of application, and joint profile. Remove deteriorated mortar by hand raking or other means equally sensitive to the historic material.



---

## EXISTING BUILDINGS

### SHUTTERS

#### Appropriate

When shutters are appropriate to the building style and supported Porches are often the focus of historic buildings, particularly when they occur on primary elevations. Together with their functional and decorative features such as doors, steps, **balustrades**, **pilasters**, **entablatures**, and trim work, they can be extremely important in defining the overall historic character of a building. Their retention, protection, and repair always should be considered carefully when planning rehabilitation work.

### PORCHES AND DECKS

Porches are often the focus of historic buildings, particularly when they occur on primary elevations. Together with their functional and decorative features such as doors, steps, Balustrades, pilasters, entablatures, and trim work, they can be extremely important in defining the overall character of a building. Their retention, protection, and repair always would be considered carefully when planning rehabilitation work.

## DISTINCTIVE DESIGN AND STRUCTURAL ELEMENTS

#### Appropriate

Retain existing original porch features and details. Repair missing or deteriorated elements or replace them with elements that duplicate the originals in design and materials. Paint new porch work.

#### *Inappropriate*

*It is inappropriate to alter details that help define the character and construction of the porch and the overall style and historical development of the building.*



---

## EXISTING BUILDINGS

### PRESERVATION OF PORCHES

#### **Appropriate**

If possible, preserve porches that contribute to the historical character of the property or have developed architectural or significance in their own right even if they are not original.

#### *For Your Information*

*The most common porches in the Prospect Hill Local Historic District are either Victorian porches with turned columns and spindles or later bungalow style porches with brick columns and limestone caps. Wrought iron is not a characteristic building material of historic porches in Bloomington.*

#### **Inappropriate**

*Avoid creating a false historical appearance by introducing porch elements that represent different construction periods, methods, or styles.*

## NEW CONSTRUCTION OR RECONSTRUCTION OF PORCHES

#### **Appropriate**

Reconstruct missing porches based on photographs, written documentation or existing physical evidence of their existence. Reconstructed porches must conform to present zoning setback requirements. In the absence of documented or physical evidence, reconstructed porches should be simple in design and ornamentation, following the guidelines for new construction.

#### **Inappropriate**

*Enclosed front porches and decks that are visible from public view are inappropriate.*

**Rehabilitation** is defined as the act or process of making possible a compatible use for a property through repair, alterations, and additions while preserving those portions or features which convey its historical, cultural, or architectural values.

1. A property will be used as it was historically or be given a new use that requires minimal change to its distinctive materials, features, spaces, and spatial relationships.
2. The historic character of a property will be retained and preserved. The removal of distinctive materials or alteration of features, spaces, and spatial relationships that characterize a property will be avoided.
3. Each property will be recognized as a physical record of its time, place, and use. Changes that create a false sense of historical development, such as adding conjectural features or elements from other historic properties, will not be undertaken.
4. Changes to a property that have acquired historic significance in their own right will be retained and preserved.
5. Distinctive materials, features, finishes, and construction techniques or examples of craftsmanship that characterize a property will be preserved.
6. Deteriorated historic features will be repaired rather than replaced. Where the severity of deterioration requires replacement of a distinctive feature, the new feature will match the old in design, color, texture, and, where possible, materials. Replacement of missing features will be substantiated by documentary and physical evidence.
7. Chemical or physical treatments, if appropriate, will be undertaken using the gentlest means possible. Treatments that cause damage to historic materials will not be used.
8. Archeological resources will be protected and preserved in place. If such resources must be disturbed, mitigation measures will be undertaken.
9. New additions, exterior alterations, or related new construction will not destroy historic materials, features, and spatial relationships that characterize the property. The new work shall be differentiated from the old and will be compatible with the historic materials, features, size, scale and proportion, and massing to protect the integrity of the property and its environment.
10. New additions and adjacent or related new construction will be undertaken in a such a manner that, if removed in the future, the essential form and integrity of the historic property and its environment would be unimpaired.

**APPLICATION FORM  
CERTIFICATE OF APPROPRIATENESS**

Case Number: 19-45

Date Filed: 7-25-19

Scheduled for Hearing: 8-8-19

\*\*\*\*\*

Address of Historic Property: 324 S. Rogers Street

Petitioner's Name: Jaime Galvan

Petitioner's Address: 324 S. Rogers Street

Phone Number/e-mail: 812-219-3117 / jaime.galvan@navy.mil

Owner's Name: Jaime Galvan

Owner's Address: 324 S. Rogers Street

Phone Number/e-mail: 812-219-3117 / jaime.galvan@navy.mil

Instructions to Petitioners

The petitioner must attend a preliminary meeting with staff of the Department of Housing and Neighborhood Development during which the petitioner will be advised as to the appropriateness of the request and the process of obtaining a Certificate of Appropriateness. The petitioner must file a "complete application" with Housing and Neighborhood Department Staff no later than seven days before a scheduled regular meeting. The Historic Preservation Commission meets the second Thursday of each month at 5:00 P.M. in the McCloskey Room. The petitioner or his designee must attend the scheduled meeting in order to answer any questions or supply supporting material. You will be notified of the Commission's decision and a Certificate of Appropriateness will be issued to you. Copies of the Certificate must accompany any building permit application subsequently filed for the work described. If you feel uncertain of the merits of your petition, you also have the right to attend a preliminary hearing, which will allow you to discuss the proposal with the Commission before the hearing during which action is taken. Action on a filing must occur within thirty days of the filing date, unless a preliminary hearing is requested.

Please respond to the following questions and attach additional pages for photographs, drawings, surveys as requested.

A "Complete Application" consists of the following:

1. A legal description of the lot. 015-24243-00 Prospect Hill Lot 7
  
2. A description of the nature of the proposed modifications or new construction:  
- add decorative round shingles and round geometric venting window to the east and south facing gables. Color to remain as current (white). Reconstruct/ addition of west side porch enclosed and canopy shed to add foundation walls and reconstruct and build addition with larger base floor. remodel attic and add access to deck built on second story addition.  
- Add foundation to shed/carriage house and straighten and stabilize walls. Update and replace carriage house windows, doors and patch/replace siding where required due to decay.
  
3. A description of the materials used.  
shed/carriage house foundation walls to be faced with limestone. windows and doors replaced with wood or wood clad.  
Siding replacement to be wood installed on the vertical. Window/doors/siding replacement style to mimic original style  
new addition siding to be wood or cement board siding. window and doors to be wood or clad. foundation to be  
faced with limestone to mimic original structure. deck railing to be wood for second and third floor decks.
  
4. Attach a drawing or provide a picture of the proposed modifications. You may use manufacturer's brochures if appropriate.
  
5. Include a scaled drawing, survey or geographic information system map showing the footprint of the existing structure and adjacent thoroughfares, Geographic Information System maps may be provided by staff if requested. Show this document to Planning Department Staff in order to ascertain whether variances or zoning actions are required.
  
6. Affix at least three photographs showing the existing full facade at each street frontage and the area of modification. If this petition is a proposal for construction of an entirely new structure or accessory building, include photographs of adjacent properties taken from the street exposure.

\*\*\*\*\*

If this application is part of a further submittal to the Board of Zoning Appeals for a Conditional Use or development standard variance, please describe the use proposed and modification to the property which will result.

**COA: 19-47**

Address: 1113 E. 1st Street

Petitioner: Emily Black

Parcel #: 53-08-04-100-074.000-009

**Rating:** Contributing

**Structure;** Colonial Revival, c. 1915



**Background:** A slightly altered Colonial Revival style home located in the Elm Heights Historic District.

**Request:** Replace steel casement and transom windows in the front of the home due to rust and general deterioration. The replacement window will be Pella Lifestyle, aluminum clad wood. The replacement will have the same size, shape, and configuration as the window being replaced.

**Guidelines:** Elm Heights Historic District Design Guidelines: Architectural Metals, pg. 22 (See next page)

**Staff Recommendation:** Staff recommends approved COA 19-47 for the following reasons:

1. **COA 24-12**, which included replacement of the front casement and transom windows, was recommended for approval by Staff and approved by the HPC at the August 9, 2012 meeting.
2. According to the district design guidelines, “Consider compatible substitute materials only if using the original material is not technically feasible”. The steel window has deteriorated and the repair of steel casement windows can be tricky and cost prohibitive. The metal clad wood replacement windows are a compatible substitute material and since the size, shape and pane configuration are not changing they will be almost indistinguishable from the original windows.

## 4.3 Architectural Metals

Architectural metals hold a significant place in the history of Elm Heights. Metals have been an integral part of the detailing and the surfacing of homes, street elements, and site features since the original development of the neighborhood. The shapes, textures, and detailing of these metals reflect the nature of their manufacture, whether wrought, cast, pressed, rolled, or extruded. Traditional architectural metals, as well as more contemporary metals, are found throughout Elm Heights. These include copper, tin, terneplate, cast iron, wrought iron, lead, brass, and aluminum.

Metals are commonly used for roofing and guttering applications, such as standing-seam roofs, flashing, gutters, downspouts, finials, cornices, copings, and crestings. Original copper guttering and steel windows retain the charm and maintain the historical character of our area. Other architectural elements, including storm doors, vents and grates, casement windows and industrial sash, railings, hardware, decorative features, and trim work, are often crafted or detailed in metal. These details make Elm Heights not only spectacular to look at but also unique in appearance. Architectural metals also appear throughout Elm Heights in the form of fences, gates, streetlights, signs, site lighting, statuary, fountains, and grates.

Our neighborhood is also home to three Lustron houses. These prefabricated, enameled steel homes were produced following World War II in an effort to reduce housing shortages due to the return of service personnel.

### Preservation Goals for Architectural Metals

To retain and restore the original architectural metals of buildings and sites through repair, coating, and routine maintenance.

## Things to Consider as You Plan

Preserving architectural metal surfaces and details requires routine maintenance and regular inspection to prevent their deterioration due to the elements or structural fatigue. Early detection of corrosion in metal surfaces is therefore essential to reduce costs. Maintaining a watertight paint film is critical to the life of metal details. The removal of all rust, followed by priming with a zinc-based primer or other rust inhibitor is an important first step. Copper and bronze surfaces should never be painted as they develop a characteristic patina over time. When corroded metals become fragile, coating with a rust converter may be the best solution to halting further damage. Unpainted soft metal elements like brass or bronze hardware may be protected from corrosion with a clear lacquer following a proper cleaning.

If a feature of a painted metal element, such as a decorative cornice, is missing or deteriorated, replacement in kind may not be feasible. In such a case, the replication of the detail in fiberglass, wood, or aluminum may be appropriate.

Asphalt products such as roofing tar can corrode metals and should never be used to patch flashing or other metal surfaces.

The care of metals can be a complicated and complex task. Consult with a specialist or the Historic Preservation Commission to best restore or maintain all metal features.



### *Guidelines for Architectural Metals*

A Certificate of Appropriateness (COA) is required for the following bolded, numbered items. The bullet points that follow each numbered item assist applicants with the COA process.

- I. Removal, replacement, or restoration of existing architectural metal elements including roofing and gutter applications, steel windows, casement windows and industrial sash, storm doors, vents, grates, railings, fencing, and all decorative features of architectural metal elements that are integral components of the building or site and visible from the right-of-way.**
  - Replace missing elements based on accurate documentation of the original or use a compatible new design. Consider compatible substitute materials only if using the original material is not technically feasible.
- II. Addition of permanent metal features including but not restricted to: buildings, roofs, doors, windows, trim, fencing, and other architectural elements.**
  - The installation of new metal garden artwork or decorative item(s) does not require a COA.

**APPLICATION FORM  
CERTIFICATE OF APPROPRIATENESS**

Case Number: COA 19-47

Date Filed: July 25, 2019

Scheduled for Hearing: 8-8-19

\*\*\*\*\*

Address of Historic Property: 1113 East First Street

Petitioner's Name: Emily Black

Petitioner's Address: 605 S Meadowbrook Dr, Bloomington, IN

Phone Number/e-mail: (202)255-8705 / mleblack@aol.com

Owner's Name: Tom Black

Owner's Address: 1113 East First St, Bloomington, IN

Phone Number/e-mail: (812) 336-2801

Instructions to Petitioners

The petitioner must attend a preliminary meeting with staff of the Department of Housing and Neighborhood Development during which the petitioner will be advised as to the appropriateness of the request and the process of obtaining a Certificate of Appropriateness. The petitioner must file a "complete application" with Housing and Neighborhood Department Staff no later than seven days before a scheduled regular meeting. The Historic Preservation Commission meets the second Thursday of each month at 5:00 P.M. in the McCloskey Room. The petitioner or his designee must attend the scheduled meeting in order to answer any questions or supply supporting material. You will be notified of the Commission's decision and a Certificate of Appropriateness will be issued to you. Copies of the Certificate must accompany any building permit application subsequently filed for the work described. If you feel uncertain of the merits of your petition, you also have the right to attend a preliminary hearing, which will allow you to discuss the proposal with the Commission before the hearing during which action is taken. Action on a filing must occur within thirty days of the filing date, unless a preliminary hearing is requested.



Please respond to the following questions and attach additional pages for photographs, drawings, surveys as requested.

A "Complete Application" consists of the following:

1. A legal description of the lot, 015-15420-00 Seminary Pt Lot 99 .13a & (27'X 50'8") LOT

2. A description of the nature of the proposed modifications or new construction:

We need to replace the picture window on the front of the home (southern exposure). The same size, style and configuration as the existing window.

3. A description of the materials used.

The new window will be Pella five -wide Lifestyle casement with five-wide transom. The exterior of the window will be white.

4. Attach a drawing or provide a picture of the proposed modifications. You may use manufacturer's brochures if appropriate.

5. Include a scaled drawing, survey or geographic information system map showing the footprint of the existing structure and adjacent thoroughfares, Geographic Information System maps may be provided by staff if requested. Show this document to Planning Department Staff in order to ascertain whether variances or zoning actions are required.

6. Affix at least three photographs showing the existing full facade at each street frontage and the area of modification. If this petition is a proposal for construction of an entirely new structure or accessory building, include photographs of adjacent properties taken from the street exposure.

\*\*\*\*\*

If this application is part of a further submittal to the Board of Zoning Appeals for a Conditional Use or development standard variance, please describe the use proposed and modification to the property which will result.

**Demo Delay: 19-14**  
**Staff Decision**

Address: 1301 S. Washington

Petitioner: Tucker Jarrol

Parcel Number: 53-08-04-310-120.000-009

Property Rating: Contributing

Circa. 1950



*Background:* This Ranch style home is listed as “Contributing” on the 2001 Interim Report and is located in the Monon Railroad Study Area.

*Request:* This is considered *partial demolition* due to the enlargement of a door, and removal of porch stoop.

*Guidelines:* According to the demolition delay ordinance, BHPC has 90 days to review the demolition permit application from the time it is forwarded to the Commission for review. The BHPC may thus employ demolition delay for 90 day from the date the application was received and may request an additional 30 days if necessary for further investigation within the first 30 days of the review period. During the demolition delay waiting period, the BHPC must decide whether to apply Local Designation to the property.

*Staff Decision:* Staff releases **Demo Delay 19-14**. Since this is a partial demolition of a Contributing structure that is zoned single family residential, staff has authority to release.



RESIDENTIAL PERMIT APPLICATION "One & Two Family Residence"

MONROE COUNTY BUILDING DEPARTMENT
501 N. Morton St RM 220, Bloomington, Indiana 47404
Phone Number:(812) 349-2580 FAX: (812) 349-2967

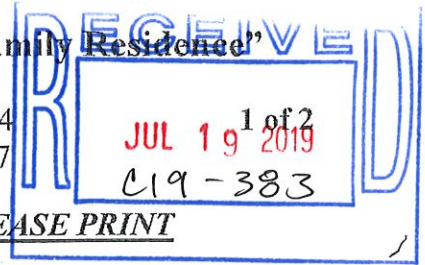

Handwritten notes: 05562, BL, 7/18/19

APPLICATION MUST BE FILLED OUT COMPLETELY; PLEASE PRINT

Parcel No. 53-08-04-310-120.000-809 Subdivision NA Lot No. NA
Project Address 1301 S. WASHINGTON City BLOOMINGTON Zip Code 47401
Township PERRY Section No.

Property Owners Name LOREN WOOD BUILDERS / SW HOLDINGS Phone No. 812-287-7575
Property Owners Address 4535 E. 3rd ST. B City BLOOMINGTON Zip Code 47401

Applicants Name TUCKER JAROLL Phone No. 219-707-9347
Applicants Address 802 N. WALNUT City BLOOMINGTON Zip Code 47408

General Contractor LOREN WOOD BUILDERS Phone No. 812-287-7575

Please check applicable boxes and fill in blanks as required:

Proposed Work: [ ] New Construction [ ] Addition [X] Remodel (area) ENTIRE Other (explain)
Rental: [ ] Yes [X] No Flood Plain: [ ] Yes [X] No Sink Holes: [ ] Yes [X] No Watershed: [ ] Yes [X] No
Building use (i.e. personal residence, duplex, storage bldg., barn, garage, etc., (explain)

PERSONAL RESIDENCE

Total number of bedrooms 3 Number of residential units 1 Estimated construction cost (census) \$150,000
Total Square Footage of proposed structure 1210
First floor square footage 1210 Garage/Carport square footage [ ] Attached [ ] Detached
Second floor square footage Covered Deck(s)/Porch(s) square footage
Third floor square footage Other Floor square footage (explain)
Basement square footage Grading area (area of soil disruption)
Elevated deck (>30") square footage N/A

Driveway Permit No. N/A [ ] State of Indiana [ ] Monroe County [ ] City of Bloomington
Wastewater system to be connected to: [X] City of Bloomington Sewer [ ] Other sanitary system
Septic System: Permit no. N/A Number of bedrooms on permit 2

The applicant hereby certifies and agrees as follows: (1) I am authorized to make application. (2) I have read this application and attest that the information furnished is correct, including that contained in plans. (3) If there is any misrepresentation in this application, or associated documents, Monroe County may revoke any permit or Certificate of Occupancy issued based upon this misinformation. (4) I agree to comply with all Monroe County Ordinances, permit conditions and State statutes which regulate building construction, use, occupancy and site development. (5) I grant and will request Monroe County Officials to enter onto the property listed on this application for the purpose of inspecting the work permitted by this application and posting notices. (6) I will retain the Certificate of Occupancy in my records upon completion of the project. NOTE: Plans shall mean all site and construction plans and specifications, whether furnished prior to or subsequent to the application date. All plans furnished subsequent to application date constitute an amendment to the original application and must be specifically approved by the County with an appropriate endorsement and the signature of the approving official prior to plan implementation. The Permit is not valid, and work is not permitted until signed and issued by the agent of the Monroe County Building Department.

Signature of Applicant: Tucker Jaroll Date: 07/11/19
Email address tucker@lorenwoodbuilders.com 08/26/2016/Bldg/Reviews/Forms

13  
3  
16

Jim Fielder  
Monroe County Recorder IN  
IN 2001023518 WAR  
11/06/2001 09:42:04 2 PGS  
Filing Fee: \$16.00

TAX ID # 012-10900-00

Send tax statements to:  
3955 N. Hinkle Road  
Bloomington IN 47408

WARRANTY DEED

THIS INDENTURE WITNESSETH, That Hilda G. Head, as Trustee, under the Hilda G. Head Revocable Trust dated March 12, 1997, Grantor, of MONROE County, in the State of Indiana, CONVEYS AND WARRANTS to Jill Leigh Hundley and Robert Joel Keefer, as joint tenants with rights of survivorship and not as tenants in common of MONROE County, in the State of Indiana, in consideration of the sum of One Dollar (\$1.00) and other valuable consideration, the receipt whereof is hereby acknowledged, the following described Real Estate in MONROE County, in the State of Indiana, to-wit:

A part of the Northwest quarter of the Northeast quarter of Section 22, Township 9 North, Range 1 West, Monroe County, Indiana more particularly described as follows: Commencing at a 4-inch by 7-inch stone with a scribed "X", marking the Northwest corner of the Northwest quarter of the Northeast quarter of said Section 22, Township 9 North, Range 1 West; thence South 00 degrees 09 minutes 00 seconds East, along the West line of said Northwest quarter section, (basis of bearings per Dann and Brenda Small Deed Record 397, page 39, Office of the Recorder of Monroe County), 748.69 feet to the point of beginning, being marked by a 5/8 inch rebar with yellow cap stamped "Bledsoe Tapp PC50920004" (BT rebar), said point of beginning also being on the West line of Hilda G. Head Deed Record 104, page 563 as found in the office of said Recorder; thence through said Head South 81 degrees 45 minutes 00 seconds East, 1012.81 feet to a railroad spike in the center of Hinkle Road; thence along said centerline of Hinkle Road the following 4 courses: 1. South 15 degrees 05 minutes 59 seconds West, 151.47 feet; 2. South 33 degrees 20 minutes 19 seconds West, 48.21 feet; 3. South 50 degrees 38 minutes 39 seconds West, 51.11 feet; 4. South 56 degrees 32 minutes 36 seconds West, 26.64 feet to a railroad spike; thence North 76 degrees 13 minutes 52 seconds West, 30.41 feet to a 3/4 inch iron pipe; thence continuing North 76 degrees 13 minutes 52 seconds West, 801.52 feet to a 3/4 inch iron pipe; thence continuing North 76 degrees 13 minutes 52 seconds West, 68.18 feet to the West line of said Head and the West line of said Northwest quarter of the Northeast quarter of said Section 22; thence North 00 degrees 09 minutes 00 seconds West, along said West line 164.43 feet to the point of beginning, containing 4.67 acres, more or less.

Subject to a 25 foot dedicated right-of-way along Hinkle Road.

The undersigned hereby represents that this real estate is not "property" as defined in Indiana Code 13-11-2-174, and is not, and has not been used as a landfill or dump, and contains no underground storage tanks or toxic or hazardous

DULY ENTERED  
FOR TAXATION

NOV 6 2001

*Roberta M. Clark*  
Auditor Monroe County, Indiana

waste or materials, and that no disclosure statement under Indiana Code 13-25-3-7, et. seq. (Indiana Responsible Property Transfer Law), is required for this transaction.

Subject to the real estate taxes for the year 2002 due and payable in May and November 2001, and all subsequent taxes thereto.

Subject to an Easement from Emma D. Glaubke, single granted to Morgan County Rural Electric Membership Corporation dated January 15, 1948 and recorded February 5, 1948 in Miscellaneous Record 25 pages 20-21 in the office of the Recorder of Monroe County, Indiana.

Subject to the Right of Way Easement from Hilda G. Head granted to Morgan County Rural Electric Membership Corporation dated July 19, 1979 and recorded September 11, 1979 in Deed Record 270 pages 469-470 in the office of the Recorder of Monroe County, Indiana.

The undersigned Hilda G. Head, Trustee, now executes this Trustee's Deed on behalf of the grantor and represents and certifies that she is the Trustee of the Hilda G. Head Revocable Trust dated March 12, 1997, and that she has full authority and power to execute this deed pursuant to the terms and conditions as set out in the above described trust.

In Witness Whereof, The said Hilda G. Head, Trustee has hereunto set her hand and seal, this 1st day of November, 2001.

*Hilda G. Head*  
Hilda G. Head, Trustee  
BY: *Thomas E. Dent*  
SUCCESSION TRUST  
ATTORNEY IN FACT.

2001020681

STATE OF INDIANA        )  
                                  ) SS:  
COUNTY OF MONROE     )

Before me, the undersigned, a Notary Public in and for said County and State, this 1st day of November, 2001, came Hilda G. Head, Trustee, and acknowledged the execution of the foregoing instrument.

Witness my hand and seal.

*Mark G. Peters*  
MARK G. PETERS  
a Notary Public

A Resident of MONROE County, IN

My Commission Expires: 01/18/2008

This Instrument Prepared By Vincent S. Taylor, Attorney at Law T11581





E Driscoll DR

S Washington ST

Perry

S Washington ST

Bloomington

E Driscoll DR

**HUNDLEY/KEEFER**  
Project - HUNDLEY/KEEFER-RES REM-1301  
Address - 1301 WASHINGTON ST S  
Parcel - 53-08-04-310-120,000-009  
App # - 66582 Twp - PR-4  
JUL 1 2019  
RECEIVED

RECEIVED  
JUL 1 2019  
BY: [unclear]

Proposed Remodel

# 1301 S WASHINGTON

1301 S Washington , Bloomington Indiana ° July, 2019

1301 S WASHINGTON

**GENERAL DEMOLITION NOTES**

- A. ALL DASHED ITEMS TO BE REMOVED.
- B. CONTRACTOR SHALL VERIFY IN FIELD LIMITS OF DEMOLITION REQUIRED BASED ON NEW WORK.
- C. COORDINATE CIVIL, MECHANICAL, PLUMBING AND ELECTRICAL FOR ADDITIONAL ITEMS TO BE DEMOLISHED AND FOR ADDITIONAL INFORMATION REQUIRED TO PREPARE FOR NEW WORK.
- D. PROTECT AND SECURE STRUCTURE WHEN REMOVING ITEMS. NOTIFY ENGINEER OF ANY STRUCTURAL CONCERNS.
- E. WHERE REMOVAL OF ITEMS LEAVES HOLES AND DAMAGED SURFACES THAT WILL BE EXPOSED IN FINISHED WORK, PATCH AND REPAIR TO MATCH ADJACENT FINISHED SURFACES.

**DEMOLITION NOTES**

- 1. REMOVE ALL EXISTING FENCING
- 2. REMOVE EXISTING DRIVEWAY CONCRETE
- 3. REMOVE EXISTING SIDEWALK
- 4. REMOVE EXISTING ANTENNA

S WASHINGTON

E DRISCOLL

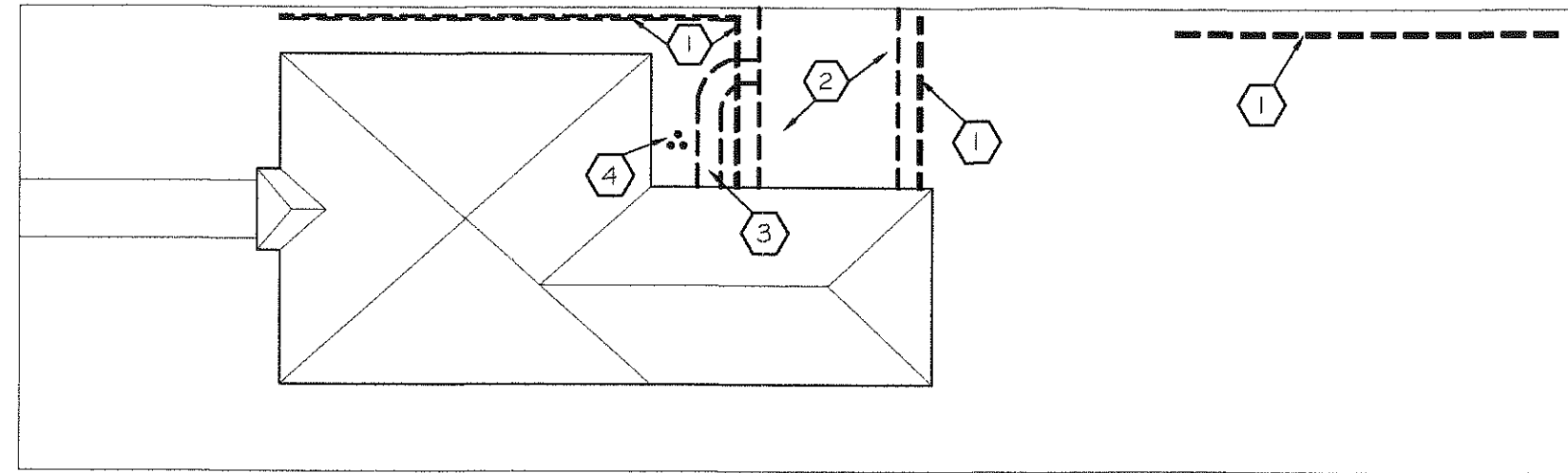

**A** EXISTING / DEMO  
**SITE PLAN**  
SCALE: 1" = 15'

**LOREN WOOD BUILDERS**  
4635 E 9th St  
Bloomington, IN 47401  
LORENWOODBUILDERS.COM

CERTIFIED

REVISIONS

PROPOSED REMODEL  
**1301 S WASHINGTON**  
1301 S WASHINGTON  
BLOOMINGTON INDIANA

PROJECT NO.: 2019  
DATE: 07/17/19  
DRAWN BY: TMJ  
CHECKED BY: ECC

EXISTING  
DEMOLITION  
SITE PLAN

**SITE**



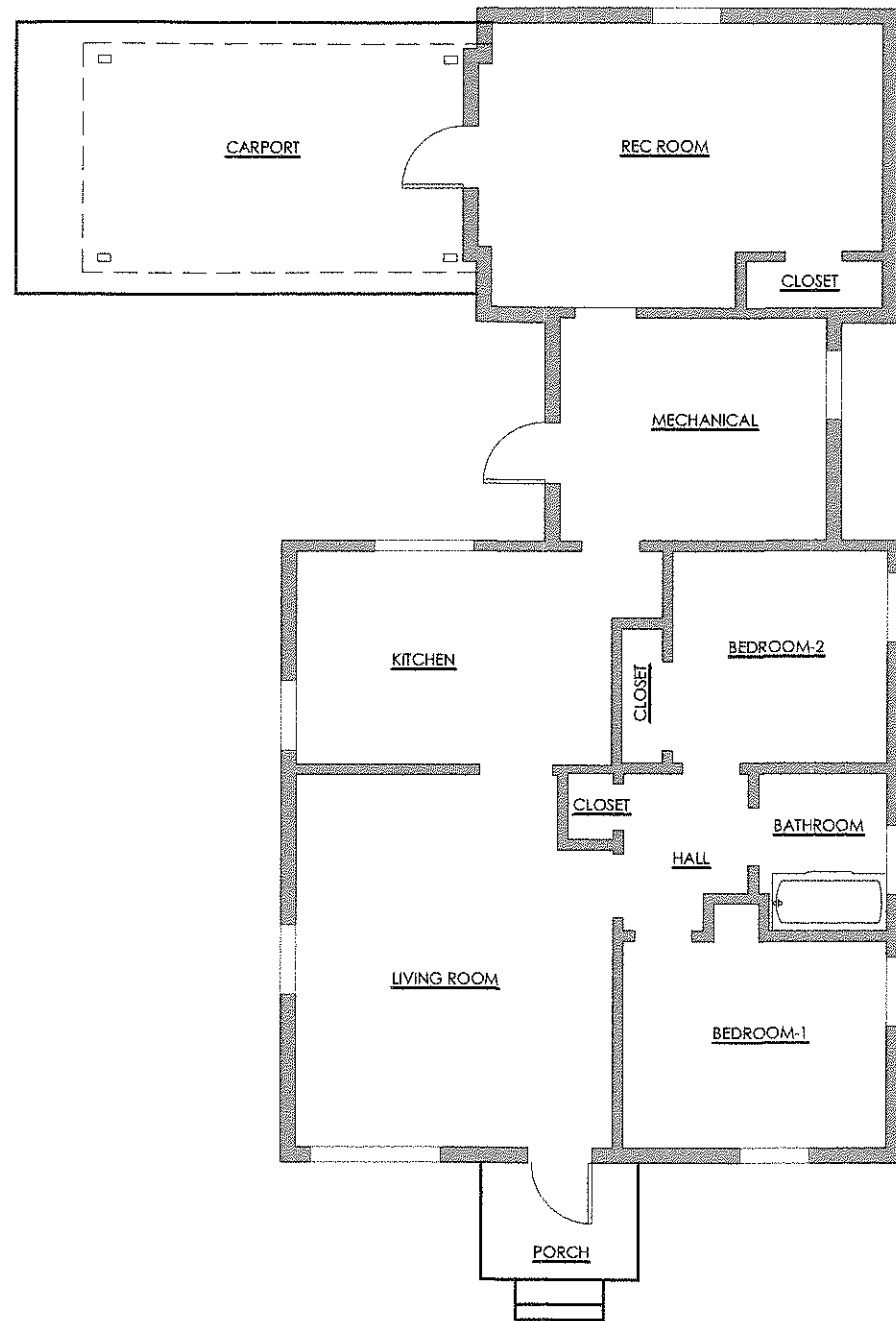

**A** EXISTING FLOOR PLAN  
SCALE: 1/8" = 1'-0"

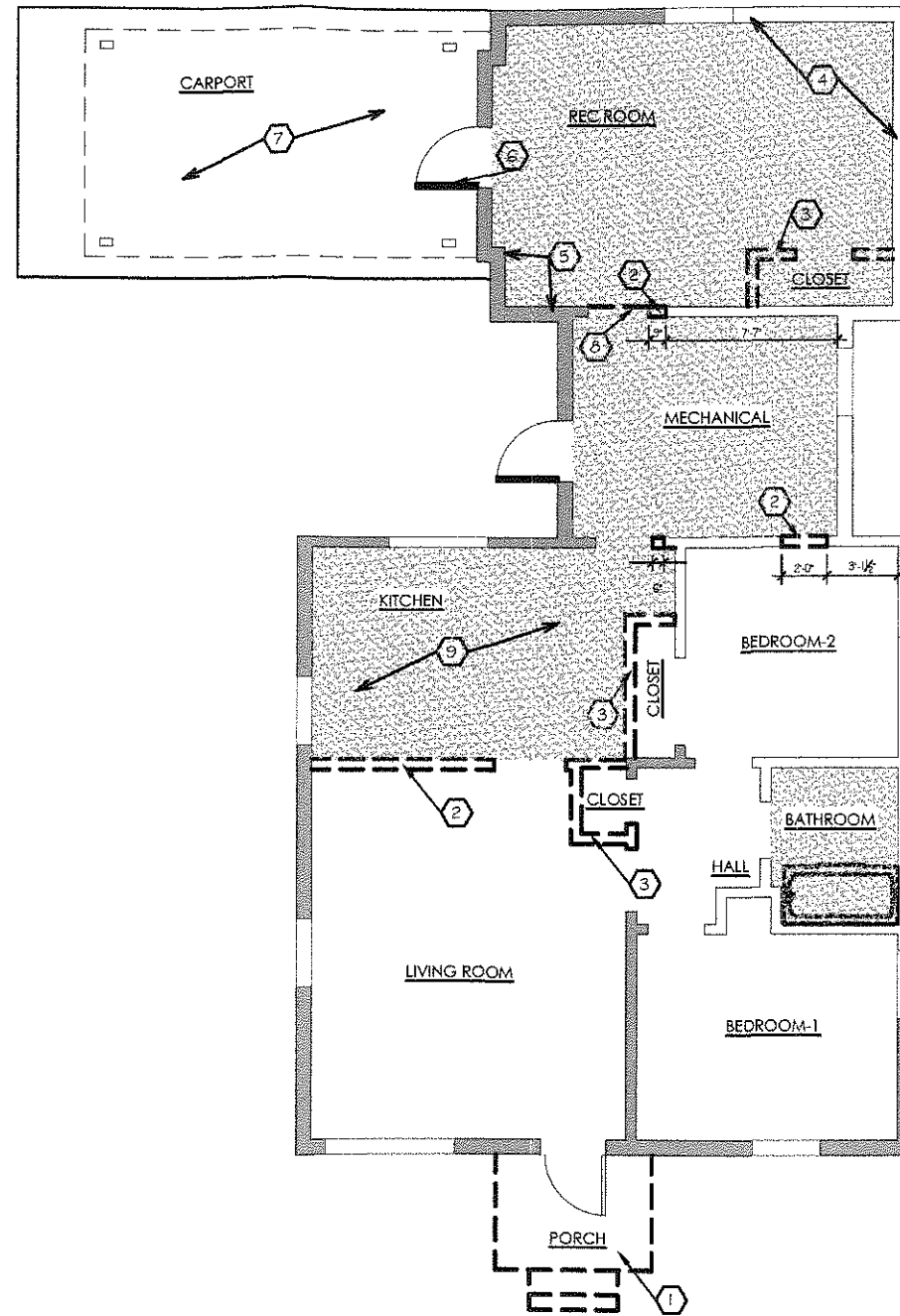

**B** DEMO FLOOR PLAN  
SCALE: 1/8" = 1'-0"

**GENERAL DEMOLITION NOTES**

- A. ALL DASHED ITEMS TO BE REMOVED.
- B. CONTRACTOR SHALL VERIFY IN FIELD LIMITS OF DEMOLITION REQUIRED BASED ON NEW WORK.
- C. COORDINATE CIVIL, MECHANICAL, PLUMBING AND ELECTRICAL FOR ADDITIONAL ITEMS TO BE DEMOLISHED AND FOR ADDITIONAL INFORMATION REQUIRED TO PREPARE FOR NEW WORK.
- D. PROTECT AND SECURE STRUCTURE WHEN REMOVING ITEMS. NOTIFY ENGINEER OF ANY STRUCTURAL CONCERNS.
- E. WHERE REMOVAL OF ITEMS LEAVES HOLES AND DAMAGED SURFACES THAT WILL BE EXPOSED IN FINISHED WORK, PATCH AND REPAIR TO MATCH ADJACENT FINISHED SURFACES.

**DEMOLITION NOTES**

- 1. REMOVE EXISTING CEMENT PORCH
- 2. REMOVE EXISTING WALL
- 3. REMOVE EXISTING CLOSET AND DOOR FRAME
- 4. REMOVE EXISTING FLOORING [SHADED AREA]
- 5. REMOVE EXISTING SHIPLAP SIDING
- 6. REMOVE EXISTING DOOR AND FRAME
- 7. REMOVE EXISTING CARPORT
- 8. REMOVE EXISTING STAIR IN ORDER TO PREPARE FOR INSULATING AND FRAMING UP EXISTING REC ROOM
- 9. DEMO EXISTING KITCHEN

**WALL LEGEND**

- WALLS TO REMAIN
- WALL TO BE DEMOLISHED

**LOREN WOOD BUILDERS**  
 4535 E. 34th St  
 B12, 287, 7895  
 BLOOMINGTON, IN 47401  
 LORENWOODBUILDERS.COM

CERTIFIED

REVISIONS

PROPOSED REMODEL  
**1301 S WASHINGTON**  
 1301 S WASHINGTON  
 BLOOMINGTON  
 INDIANA

PROJECT NO.: 2019  
 DATE: 07/19  
 DRAWN BY: TAU  
 CHECKED BY: ECC

EXISTING DEMOLITION FLOOR PLAN

**D.101**

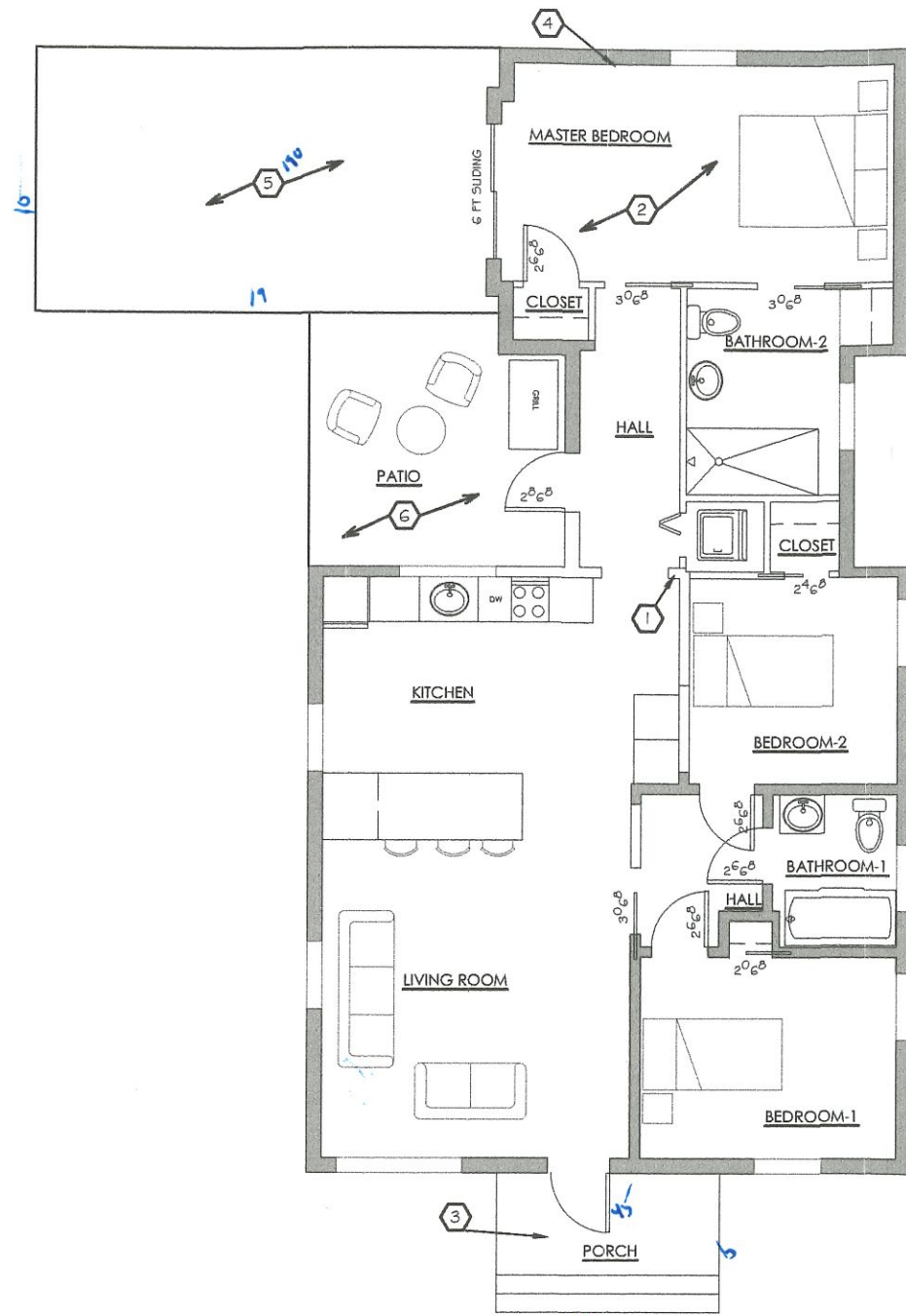

**A** PROPOSED FLOOR PLAN  
 SCALE: 1/8" = 1'-0"

**GENERAL PLAN NOTES**

- A. GENERAL CONTRACTOR TO FIELD CHECK AND VERIFY ALL DIMENSIONS AND CONDITIONS. REPORT DISCREPANCIES TO ARCHITECT BEFORE PERFORMING WORK.
- B. COORDINATE WORK OF OTHER TRADES WITH YOUR TRADE PRIOR TO STARTING ANY CONSTRUCTION.
- C. ALL DIMENSIONS SHOWN ARE FROM FACE OF STUD, FACE OF MASONRY OR CENTERLINE OF COLUMN, UNLESS OTHERWISE NOTED.
- D. ALL EXISTING HARDWOOD FLOORS TO BE REFINISHED

**MAIN FLOOR PLAN NOTES**

- 1. NEW CASED OPENING
- 2. EXISTING FLOOR TO BE FRAMED UP AND INSULATED IN ORDER TO MATCH THE REST OF HOME
- 3. NEW 8' CONCRETE PORCH
- 4. NEW DRYWALL
- 5. NEW CONCRETE SLAB
- 6. NEW LIMESTONE PATIO

**WALL LEGEND**

- EXISTING WALL
- NEW WALL

**LOREN WOOD BUILDERS**  
 4635 E 2nd St  
 Bloomington, IN 47401  
 LORENWOODBUILDERS.COM

CERTIFIED

REVISIONS

PROPOSED REMODEL  
**1301 S WASHINGTON**  
 1301 S WASHINGTON  
 BLOOMINGTON INDIANA

PROJECT NO.: 2019  
 DATE: 07/17/19  
 DRAWN BY: TMJ  
 CHECKED BY: ECC

PROPOSED FLOOR PLAN  
**A101**

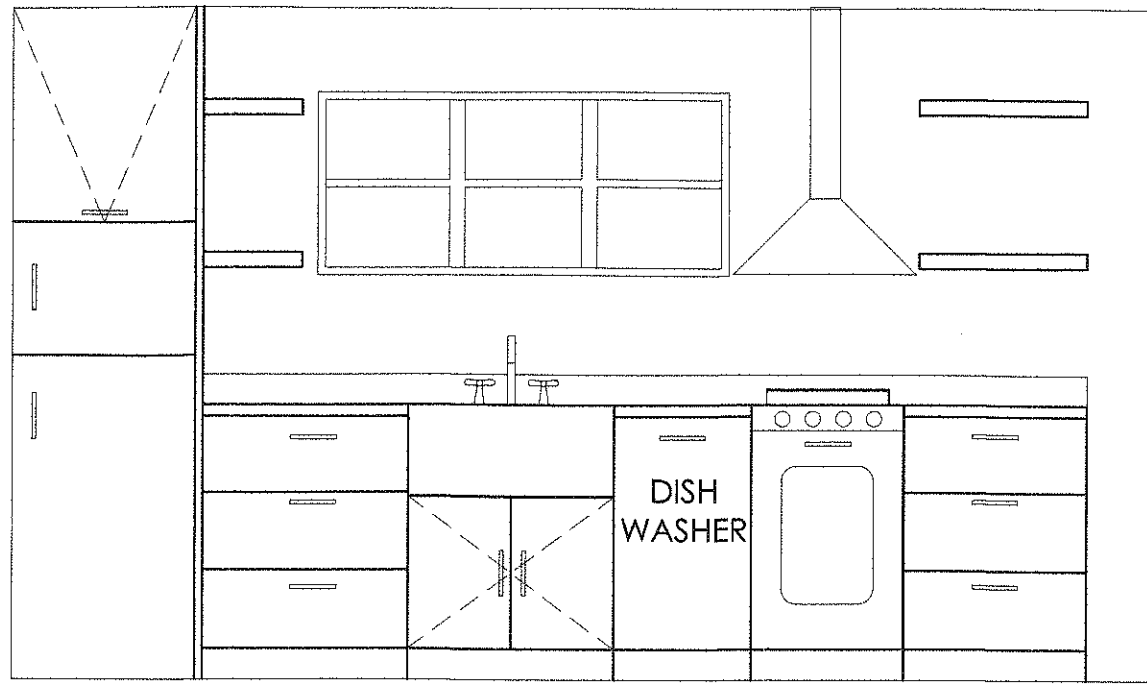

FRIDGE 24      B27      SINK27    DW18      OVEN20      B24

**D** PROPOSED  
**KITCHEN ELEVATION**  
SCALE: 1/4" = 1'-0"

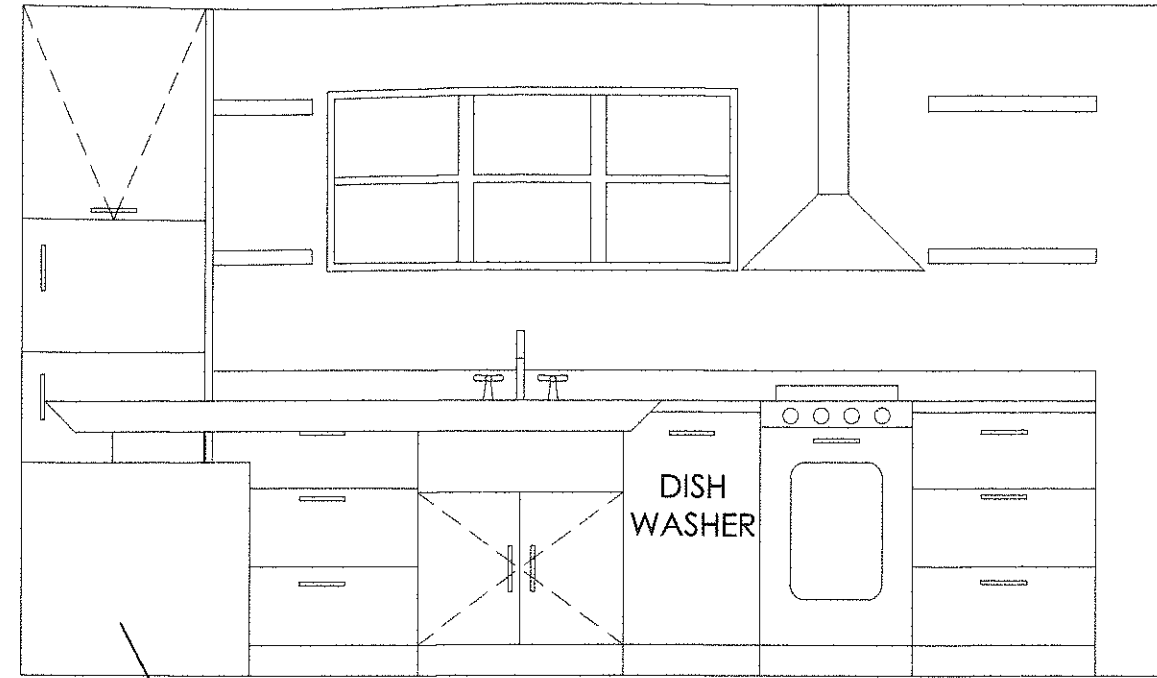

**C** PROPOSED  
**KITCHEN ELEVATION**  
SCALE: 1/4" = 1'-0"

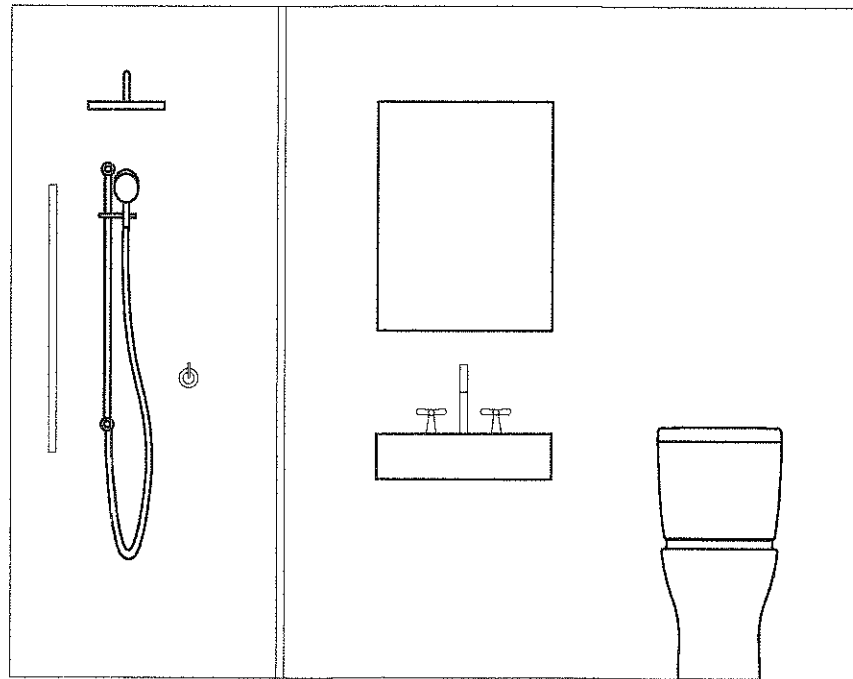

**B** PROPOSED  
**BATHROOM-2 ELEVATION**  
SCALE: 1/4" = 1'-0"

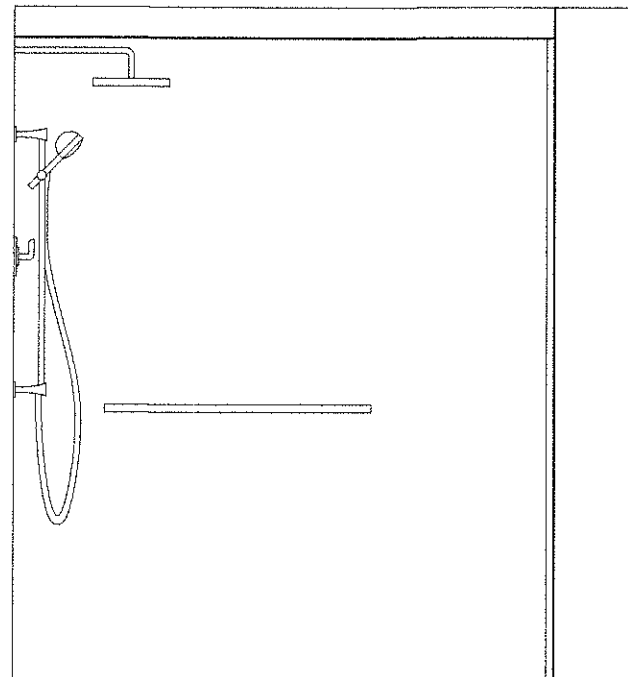

**A** PROPOSED  
**BATHROOM-2 ELEVATION**  
SCALE: 1/4" = 1'-0"

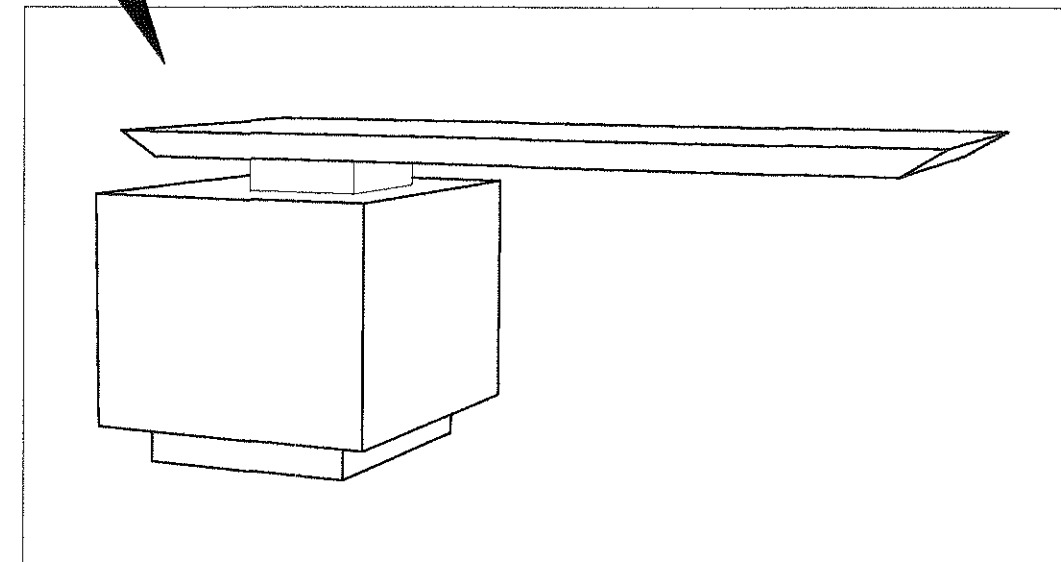

LOREN WOOD BUILDERS

4335E 34th St  
817.287.7575  
BLOOMINGTON, IN 47401  
LORENWOODBUILDERS.COM

CERTIFIED

REVISIONS

PROPOSED REMODEL  
**1301 S WASHINGTON** INDIANA  
1301 S WASHINGTON  
BLOOMINGTON

PROJECT NO.: 2019  
DATE: 07/17/19  
DRAWN BY: TAJ  
CHECKED BY: ECC

PROPOSED ELEVATION

**A.201**



**GENERAL DEMOLITION NOTES**

- A. ALL DASHED ITEMS TO BE REMOVED.
- B. CONTRACTOR SHALL VERIFY IN FIELD LIMITS OF DEMOLITION REQUIRED BASED ON NEW WORK.
- C. COORDINATE CIVIL, MECHANICAL, PLUMBING AND ELECTRICAL FOR ADDITIONAL ITEMS TO BE DEMOLISHED AND FOR ADDITIONAL INFORMATION REQUIRED TO PREPARE FOR NEW WORK.
- D. PROTECT AND SECURE STRUCTURE WHEN REMOVING ITEMS. NOTIFY ENGINEER OF ANY STRUCTURAL CONCERNS.
- E. WHERE REMOVAL OF ITEMS LEAVES HOLES AND DAMAGED SURFACES THAT WILL BE EXPOSED IN FINISHED WORK, PATCH AND REPAIR TO MATCH ADJACENT FINISHED SURFACES.

**DEMOLITION NOTES**

- 1. BURY EXISTING POWER LINES
- 2. REMOVE EXISTING CARPORT
- 3. REMOVE EXISTING DOOR; PREP FOR 6' SLIDER
- 4. REMOVE EXISTING DOOR; TO BE REPLACED
- 5. NEW ROOF, GUTTERS, DOWNSPOUTS
- 6. REMOVE EXISTING CONCRETE STOOP
- 7. REMOVE STORM DOOR

**WALL LEGEND**

-  WALLS TO REMAIN
-  WALL TO BE DEMOLISHED

LOREN WOOD BUILDERS

ASS # 38833  
 BIZ. 282.7295  
 BLOOMINGTON, IN 47401  
 LORENWOODBUILDERS.COM

CERTIFIED

REVISIONS

PROPOSED REMODEL  
**1301 S WASHINGTON**  
 1301 S WASHINGTON  
 BLOOMINGTON INDIANA

PROJECT NO.: 2019  
 DATE: 07/17/19  
 DRAWN BY: TAJ  
 CHECKED BY: ECC

EXISTING  
 ELEVATIONS  
**D.201**

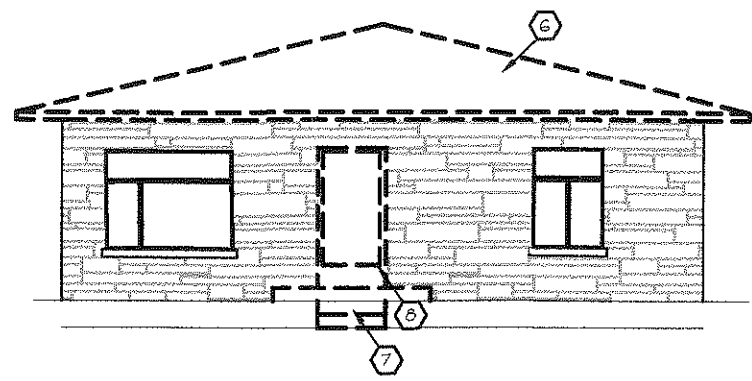

**D** EXISTING / DEMO  
**EAST ELEVATION**  
SCALE: 1/8" = 1'-0"

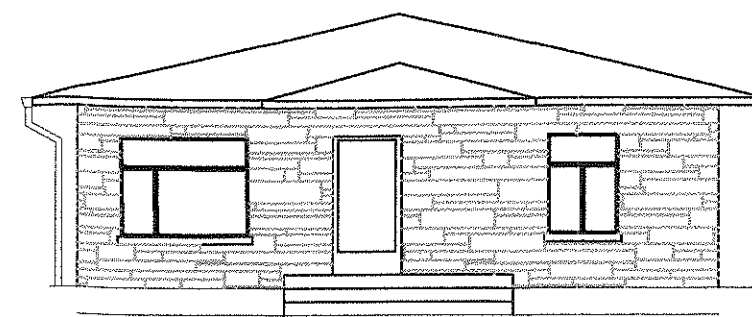

**C** PROPOSED  
**EAST ELEVATION**  
SCALE: 1/8" = 1'-0"

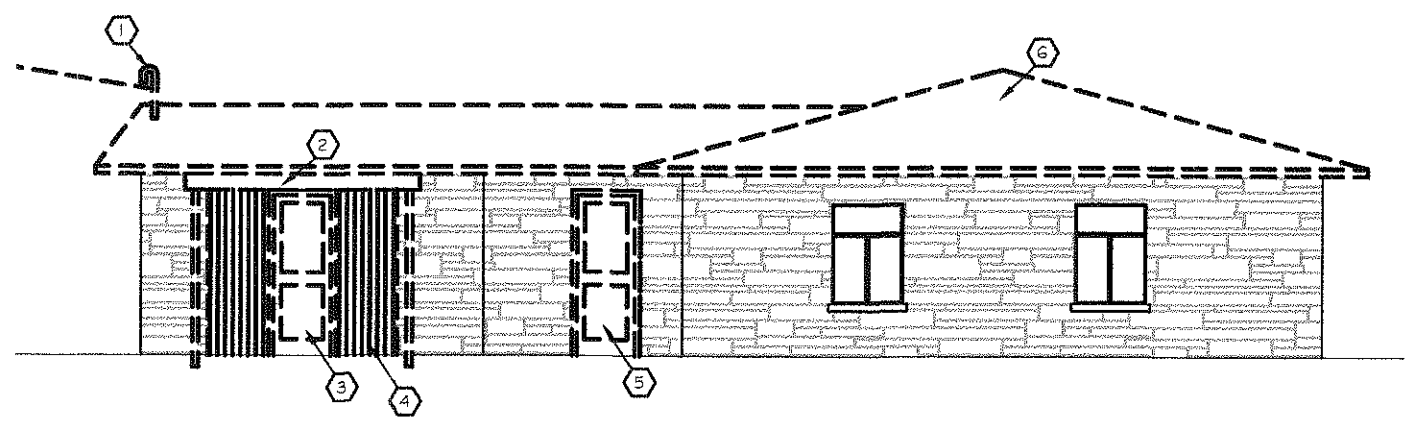

**B** EXISTING / DEMO  
**SOUTH ELEVATION**  
SCALE: 1/8" = 1'-0"

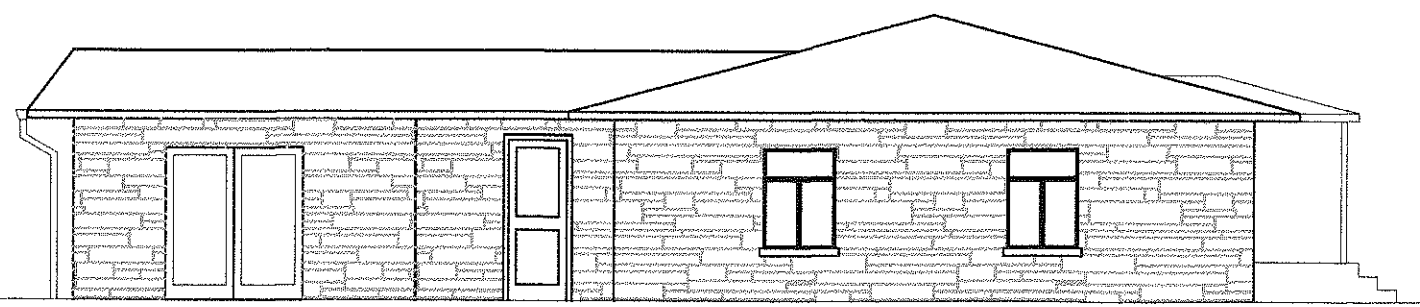

**A** PROPOSED  
**SOUTH ELEVATION**  
SCALE: 1/8" = 1'-0"

1. Any modification or intensification of a conditional use that alters the essential character or operation of the use in a way not intended by the Board of Zoning Appeals or Hearing Officer at the time the conditional use was granted shall require a new conditional use approval.
2. The Planning and Transportation Director shall determine in writing whether the proposed modification or intensification represents an alteration in the essential character of the original conditional use as approved. The operator of the conditional use shall provide the Planning and Transportation Director with all the necessary information to render this determination.
3. In the case where the Planning and Transportation Director determines a new conditional use permit is required, a petition shall be submitted, accepted, and revised, and may be withdrawn, in accordance with Section 20.06.040(c) (Petition Submittal and Processing) and this Section 20.06.050(b) (Conditional Use Permit).
4. The Hearing Officer may hear requests for amendments to a conditional use, if authorized by the Plan Commission.

---

### (c) Demolition Delay Permit<sup>1226</sup>

---

#### (1) Purpose<sup>1227</sup>

The demolition delay permit procedure is intended to ensure that no certificate of zoning compliance authorizing release of a permit allowing the demolition, substantial demolition, or partial demolition of a structure that is listed as "Outstanding" or "Notable," or demolition or substantial demolition of a structure listed as "Contributing" on the City of Bloomington Survey of Historic Sites and Structures, or any accessory structure of the same era of construction as the principal structure that is so listed, shall be issued prior to review pursuant to this Subsection C.

#### (2) Applicability<sup>1228</sup>

This Section 20.06.050(c) shall not apply to any structure that is within a property or group of properties locally designated as a historic district or a conservation district pursuant to Title 8 (Historic Preservation and Protection) of the Bloomington Municipal Code.

#### (3) Demolition Delay Permit Review Process

Figure 6.05-4 identifies the applicable steps from 20.06.040 (Common Review Procedures) that apply to demolition delay permit review. Additions or modifications to the common review procedures are noted below.

**Figure 6.05-4: Summary of Demolition Delay Permit Procedure**

<sup>1226</sup> From current 20.09.230. Did not carry forward language related to the "demolition" permit. This permit is issued at the counter and is typically associated with other petition requests. That content will be relocated to an Administrative Manual.

<sup>1227</sup> New. *Consolidated Draft: Added "demolition or substantial demolition of a structure listed as "contributing." Adoption Draft: Added "substantial demolition."*

<sup>1228</sup> Did not carry forward current 20.09.230(a). The landscaping requirements for demolition sites are already included in Section 20.04.080(l) (Vacant Lot Landscaping).

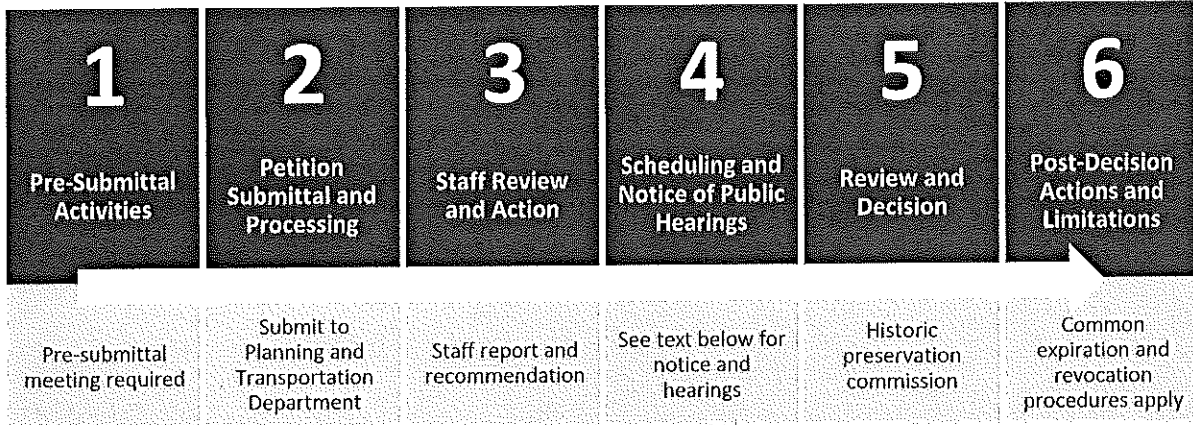

**(A) Pre-Submittal Activities**

A pre-submittal meeting is required in accordance with Section 20.06.040(b)(1) (Pre-Submittal Meeting).

**(B) Petition Submittal and Processing**

- i. The demolition delay permit petition shall be submitted, accepted, and revised, and may be withdrawn, in accordance with Section 20.06.040(c) (Petition Submittal and Processing).
- ii. If a petition for demolition or partial demolition that is subject to the demolition delay procedures of this UDO is withdrawn by the petitioner, the demolition delay period shall be terminated and no certificate of zoning compliance for the withdrawn petition shall be issued.

**(C) Staff Review and Action**

**i. Notice to Property Owner and Housing and Neighborhood Development Director**

- 1. Upon receiving a petition for a demolition or partial demolition covered by this Section 20.06.050(c), the Planning and Transportation Director shall give notice to the Housing and Neighborhood Development Director and to the property owner, or his/her representative. Such notice shall advise the property owner that the permit petition may need to be amended to include materials required by Section 20.06.050(a)(Site Plan Review) and the rules and regulations of the Historic Preservation Commission, in order for the petition to be considered complete.
- 2. Not later than 30 days after such notice is given by the Planning and Transportation Director, the Housing and Neighborhood Development Director shall give notice to the chairperson of the Historic Preservation Commission and to the property owner, if the 120 day waiting period is to be imposed pursuant to section 20.06.050(c)(3)(C)ii.

**ii. Waiting Period**

**1. Determination of Waiting Period**

The 90-day period shall apply in all cases unless the Housing and Neighborhood Development Director, or his/her designee, finds that an additional 30-day delay period is needed in order for the Historic Preservation Commission to responsibly consider and determine whether to recommend designation of the property. The

Housing and Neighborhood Development Director shall make such finding only where:

- [a] There are multiple demolition permits and/or historic designation proposals pending or expected to come before the Historic Preservation Commission during the 90-day period; or,
- [b] The demolition request presents unusually complex public policy issues due to the location or survey classification of the structure; or
- [c] The structure is located within an area that contains multiple surveyed properties, it is located within an area designated on the National Register of Historic Places, or the survey classification of the structure proposed for demolition or partial demolition is "Notable" or "Outstanding."

2. **Early Termination of Waiting Period**<sup>1229</sup>

The remainder of the waiting period shall be considered waived and the certificate of zoning compliance shall be issued if within the 90- or 120-day period one of the following occurs and all other requirements of this UDO are satisfied:

- [a] The Historic Preservation Commission votes affirmatively not to recommend local historic designation to the Common Council; or
- [b] The Historic Preservation Commission votes on a motion to recommend local designation and the motion fails; or
- [c] In cases of contributing structures in a single family district, staff for the Historic Preservation Commission decides not to recommend local historic designation to the Historic Preservation Commission and Common Council based on the same review criteria used by the Historic Preservation Commission when determining if a property should be recommended for local historic designation; or<sup>1230</sup>
- [d] The Common Council disapproves a recommended local historic designation of the subject property.

3. **Waiting Period Limited to Once per Year**

- [a] No structure that has been subjected to the waiting period under this section shall be subject to a second waiting period until one year has passed from the date of expiration of the first waiting period.
- [b] During this one-year period, no action of the Historic Preservation Commission or the Common Council may prevent issuance or effect revocation of a certificate of zoning compliance or demolition permit that is otherwise properly issued or petition that meets all requirements of the Bloomington Municipal Code and this UDO.
- [c] This provision shall not apply except to the extent that the work covered by the certificate of zoning compliance or demolition or partial demolition permit, or petition for such a certificate or permit, is substantially identical to the work shown in the submission that occasioned the first waiting period.
- [d] For purposes of this Section 20.06.050(c)(3)(C)ii:

<sup>1229</sup> Reworded for clarity and consistency.

<sup>1230</sup> Consolidated Draft: Added "In cases of contributing structures in a single family district.."



- i. "Work" includes the proposed demolition, partial demolition and any proposed construction, reconstruction, or alteration associated therewith;
- ii. "Substantially identical" means without significant deviation in any detail of any elevation or in the type, design, or location of materials that will be subject to public view; and
- iii. "Submission" shall mean the submission that is authorized to receive approval pursuant to 20.06.040(c) (Petition Submittal and Processing) of this Chapter 20.06.

4. **Emergency Waiver of Waiting Period**

The waiting period may be waived upon a written determination by the City's Housing and Neighborhood Development Department that there is an emergency condition dangerous to life, health, or property that requires demolition prior to the expiration of the waiting period.

(D) **Scheduling and Notice of Hearings**

i. **Discretionary Hearing**

The Historic Preservation Commission may conduct a hearing, at its sole discretion, during the waiting period, to determine if any structure described below should be recommended for local designation by the Common Council:

1. A "Contributing" structure located in any of multifamily or nonresidential zoning district.
2. A "Contributing" structure located in any single-family district if the staff for the HPC determines that a review of the petition necessitates full HPC review.
3. A "Notable" structure located in any zoning district of the city.
4. An "Outstanding" structure located in any zoning district of the city.

ii. **Posted Notice Required**

1. **Generally**

- [a] Within three business days of receiving notice by the Planning and Transportation Director that his/her property is subject to the waiting period provisions of this section, the owner shall place upon the property where the structure is located, in plain public view, a notice to the public of the proposed demolition or partial demolition of the structure.
- [b] The notice shall be in such form as approved by the staff and shall remain in place until termination of the waiting period.
- [c] Noncompliance with this provision shall result in the delay period being extended by an amount of time equal to the amount of time, as reasonably determined or estimated by the Planning and Transportation Director, during which the notice was not properly in place.

2. **Exemption to Posted Notice**

- [a] This section shall not apply to a petition for partial demolition of a property classified as "Contributing" in any single-family district if staff for the Historic Preservation Commission reviews and releases the petition.
  - i. Staff, for purposes of this subsection, shall be those persons who have the same or equivalent technical expertise as the members of the Historic



Preservation Commission as outlined in Section 2.16.010(c) of the Bloomington Municipal Code.

- ii. If within seven business days of the receipt of a petition the staff has not taken steps to forward the matter to the Historic Preservation Commission for further review, the petition shall be released automatically and the provisions of Section 20.06.050(c) shall apply.<sup>1231</sup>
- iii. Staff's decision shall be based on the same criteria used by the Historic Preservation Commission when it renders a determination about whether or not a property should be recommended for local historic designation.

[b] If staff for the Historic Preservation Commission determines that full Historic Preservation Commission review of a petition for a partial demolition of a property classified as "Contributing" in a single-family district is necessary, then the owner shall post the notice described in subsection ii.1 above on the property.

iii. **Published Notice Required**<sup>1232</sup>

Published notice pursuant to Section 20.06.040(e) is required except as modified to comply with Indiana State Code § 36-7-9-7. Notice must be published at least three times before demolition, with the first publication no more than 15 days after a petition to demolish the structure is filed, and the final publication at least 15 days before the issuance of a demolition permit.

**(E) Review and Decision**

- i. After expiration of the waiting period, which shall include early termination of the waiting period, a certificate of zoning compliance authorizing demolition shall be issued if the property owner has submitted a complete petition and all other requirements of the Bloomington Municipal Code and this UDO are met.
- ii. For any structure that is exempt from the waiting period of this section, a certificate of zoning compliance authorizing release of a demolition or partial demolition permit shall be issued within a reasonable time following receipt by the Planning and Transportation Department of a complete petition, provided all other requirements of the Bloomington Municipal Code and this UDO are met.
- iii. If within the 90 or 120 day waiting period the property is placed under interim protection or is locally designated as a historic or conservation district pursuant to Chapter 8.08, (Historic Districts and Standards) of the Bloomington Municipal Code, then no certificate of zoning compliance authorizing demolition or partial demolition may be issued except:
  1. Upon termination of interim protection without historic or conservation district designation being placed upon the property; or,
  2. Where historic or conservation district designation is placed upon the property, in accordance with and after all approvals required by Chapter 8.08 (Historic Districts and Standards) of the Bloomington Municipal Code.

<sup>1231</sup> Consolidated Draft: Changed from "staff has forwarded" to "staff has taken steps to forward."

<sup>1232</sup> Consolidated Draft: New to comply with Indiana State Code § 36-7-9-7.

**(F) Post-Decision Actions and Limitations<sup>1233</sup>**

Post-decision actions and limitations in Section 20.06.040(h) shall apply with the following modifications:

- i. The recipient of a permit or other approval subject to this section shall be bound to the details of the elevations, and the design, type, and location of materials depicted in the submission and may not deviate from such depiction, except as modified and approved at one or more public meetings of the Historic Preservation Commission, without applying for a new certificate of zoning compliance, petition for which shall commence a new waiting period.
- ii. No action of the Historic Preservation Commission may prevent issuance or effect revocation of such certificate of zoning compliance, or a demolition permit issued in reliance upon such certificate of zoning compliance, for a period of one year from the end of the waiting period.

---

**(d) Floodplain Development Permit<sup>1234</sup>**

---

**(1) Purpose**

The floodplain development permit procedure is intended to minimize public and private losses due to flood conditions in specific areas and to provide a mechanism to ensure compliance with this UDO by providing a thorough permitting and inspection process for all floodplain development activities.

**(2) Applicability**

- (A) No development shall occur in any special flood hazard area (SFHA) and known flood prone areas, unless a grading permit for such activity has been issued.
- (B) Compliance with the standards in this UDO shall not relieve any person of the independent obligation to comply with all applicable standards and practices established in federal and state law and all other applicable rules, regulations, standards and specifications of the City regarding development within a floodplain.

**(3) Floodplain development permit Review Process**

Figure 6.05-6 identifies the applicable steps from 20.06.040 (Common Review Procedures) that apply to floodplain development permit review. Additions or modifications to the common review procedures are noted below.

---

<sup>1233</sup> Replaces current 20.09.040(b). Reworded for clarity and consistency.

<sup>1234</sup> Consolidated Draft: New procedure to align with the state model floodplain ordinance.

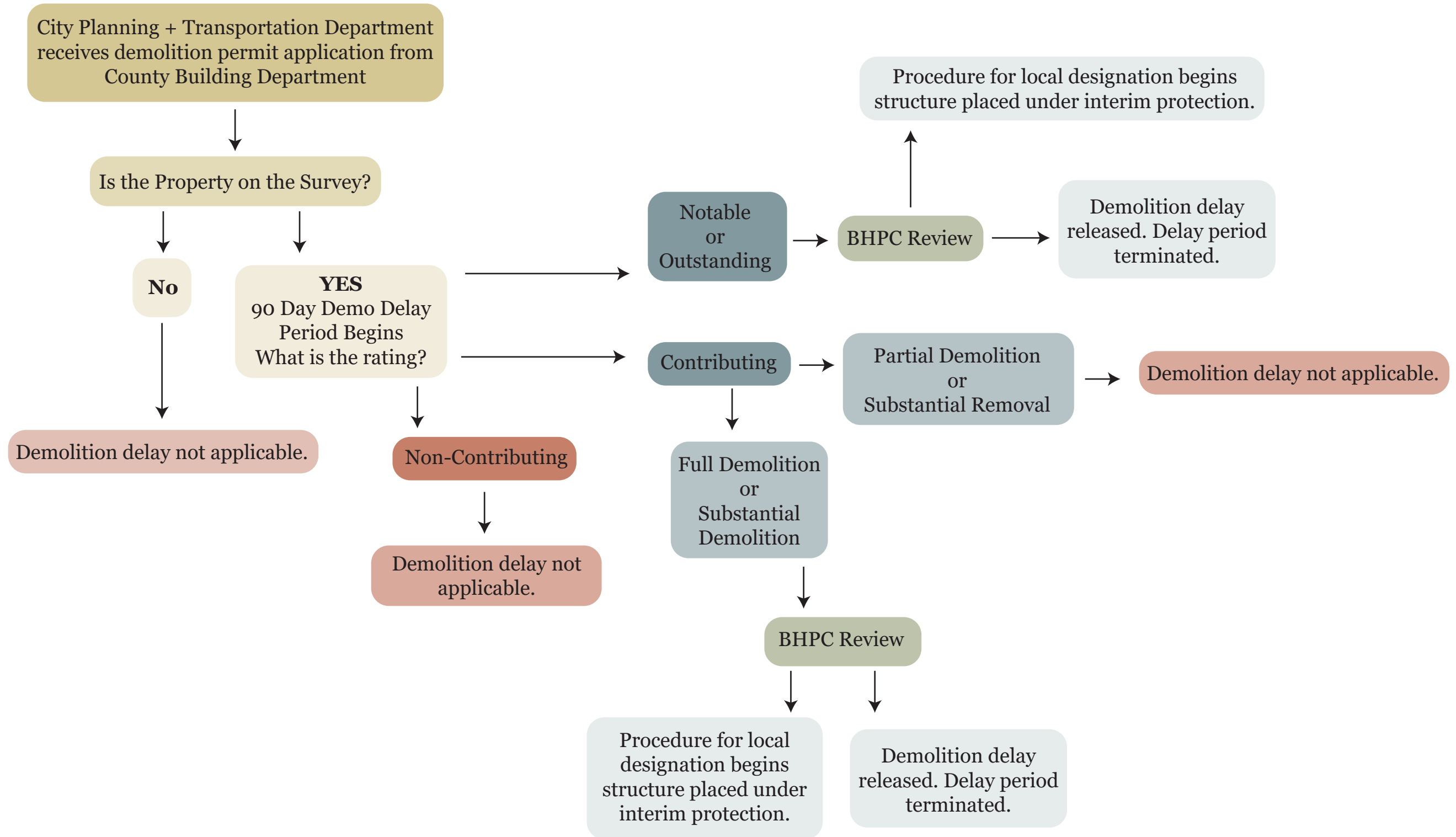

**Demolition** - the complete removal or destruction of any structure excluding its foundation

**Substantial Demolition** - the moving or razing of a building including the removal or enclosure of fifty percent or more of the structure

**Partial Demolition** - means the complete or substantial removal or destruction of any exterior portion of a structure, which shall include but not be limited to:

1. Complete or substantial removal or destruction of a porch, wing, cupola, addition, or similar feature
2. Partial demolition of a roof shall include work that results in any change to the pitch of any portion of the roof, or; covering or otherwise obscuring the existing roof with a new roof of different pitch or material, or; adding any gable, dormer or other similar feature to an existing roof
3. Any work resulting in the obscuring from view of forty percent or more of the exterior of any facade on the structure; or, removal or destruction of the exterior surface of forty percent or more of the area of any exterior facade on the structure
4. Construction or attachment of any addition to a structure
5. Replacement of any window or door where the window or door opening is enlarged or obscured from view
6. Creation of any new window or door opening

**Substantial Removal** - as used in the definition of “partial demolition” means an alteration, pulling down, destruction or removal of a portion of a structure which jeopardizes a structure’s individual eligibility for listing in the National Register of Historic Places, or its status as a contributing structure in a national, state or local register of historical places, which shall include, but not be limited to, the removal of a defining architectural feature or element which defines or contributes to the historic character of the structure

**The property at 523 W. 7th Street qualifies for local designation under the following highlighted criteria found in Ordinance 95-20 of the Municipal Code (2) a, e, g:**

- (1) Historic:
  - a) Has significant character, interest, or value as part of the development, heritage, or cultural characteristics of the city, state, or nation; or is associated with a person who played a significant role in local, state, or national history; or
  - b) Is the site of an historic event; or
  - c) Exemplifies the cultural, political, economic, social, or historic heritage of the community.
  
- (2) Architectural:
  - a) **Embodies distinguishing characteristics of an architectural or engineering type; or**
  - b) Is the work of a designer whose individual work has significantly influenced the development of the community; or
  - c) Is the work of a designer of such prominence that such work gains its value from the designer's reputation; or
  - d) Contains elements of design, detail, materials, or craftsmanship which represent a significant innovation; or
  - e) **Contains any architectural style, detail, or other element in danger of being lost; or**
  - f) Owing to its unique location or physical characteristics, represents an established and familiar visual feature of the city; or
  - g) **Exemplifies the built environment in an era of history characterized by a distinctive architectural style**

**Background:** The proposed single-property district at 523 W. 7th Street is an approximately 1,300 square foot single-family home located on a 0.21 acre parcel in the West Side National Register Historic District. The home was constructed in 1895 and first noted in the 1907 Sanborn Fire Insurance Maps. The structure is a vernacular architectural form known as the Central Passage with Queen Anne stylistic details. It has been altered with vinyl siding and an addition to the east side. The home is currently in a dilapidated condition due to neglect by the owners who have intentionally left the home vacant for at least fifteen years. The property was given a “Notable” rating on the 2003 City of Bloomington Interim Report but was downgraded to “Contributing” on the 2015 SHAARD survey possibly due to its deteriorated condition and the surveyor’s failure to incorporate the significance of the architectural form in the survey’s evaluation of the home. The most recent historic survey conducted by Bloomington Restorations Inc. in 2018 rated the structure as “Notable” due to its architectural significance. The owners have proposed full demolition of the home. After undergoing demolition delay review, the BHPC made a motion at the July 11, 2019 meeting to start the designation review process.



**Architectural Significance:**

(A) *Embodies distinguishing characteristics of an architectural or engineering type.*

(Picture of the Stancombe House. Taken c. 2010.)

The structure at 523 W. 7th can be categorized as a Central Passage form with Queen Anne details. The Central Passage is a vernacular architectural form constructed through the colonial period up until the late nineteenth-century in the United States. It is an adaptation of the Hall and Parlor form brought by British colonists to the United States during the colonial period. The Hall and Parlor form is named after its characteristic two room wide, one story tall arrangement. It consisted of a larger common space known as a “hall” that was the center of household activity and a smaller private room called the “parlor” that was often used for sleeping. The single front entry door opened directly into the hall, welcoming guests directly into the home and forgoing any pretensions of privacy.

American hall and parlor house floor plan

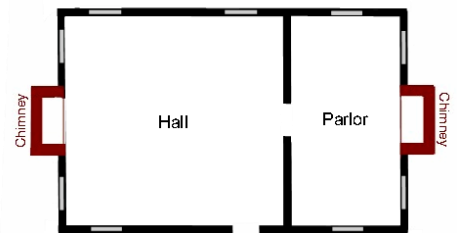

The Central Passage is a climactic adaptation of the British Hall and Parlor form in order to accommodate the warmer summers of the Upper South. The addition of a central passage through the middle of the building created air currents that pulled cooler outside air into the interior which effectively cooled the home in an era before air-conditioning.

Central-passage house floorplan

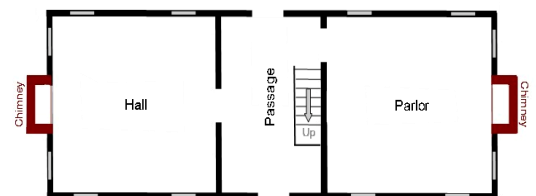

While the form of the home is Central Passage, stylistically it is Queen Anne. Two projecting bay windows flanking the front door and the use of decorative shingles material to create a textured wall surface on the gable of the front porch are elements common to the Queen Anne style which would have been in vogue when the structure was built in 1895.

(E) *Contains any architectural style, detail, or element in danger of being lost.*

The Stancombe House is the only remaining Central Passage home identified in Bloomington. Adjacent to the home is 513 W. 7th, which has a similar date of construction and is built in the double pen form—another vernacular architectural form. Taken together, these two homes offer a rare glimpse into the lived experience of nineteenth century working class Bloomingtonians.



*(G) Exemplifies the built environment in an era of history characterized by a distinctive architectural style.*

(Saddlebag home on Old State Road 37 outside Bloomington, Indiana)

The Central Passage is one of several vernacular forms including I-Houses, Saddlebags, and Double Pens, which according to Dr. Henry Glassie, were transported to Bloomington from the Upper South along distinct migration routes. It should be noted that vernacular forms were built using construction techniques and building proportions that were shared by a common cultural group and passed down orally through the centuries with little deviation or change. Cultural geographer Fred Kniffen and folklorist Henry Glassie traced the diffusion of cultural groups from several distinctive cultural nodes west across the United States using these easily distinguishable forms of vernacular architecture.

As railroads increasingly connected the country in the decades after the Civil War, materials were sourced from distant sawmills and catalogues containing the latest architectural styles became available to working class consumers. From 1860 to 1910, a unique phenomenon in house construction emerged. Labeled by Virginia McAlester as “National” in her seminal work on American architecture, vernacular forms and shapes persisted but were built using different materials and construction techniques and were combined with stylistic architectural elements such as Victorian bay windows and decorative shingles. It is within this distinct period of the built environment that the Stancombe house belongs.

Ensuring the survival of these exceedingly rare architectural forms is crucial to reading the material culture of Bloomington’s earliest residents while also adding a rich layer of historical context in which to place Bloomington and south central Indiana within the larger narrative of U.S. history.

(Staff recommendation on the next page)



---

**Staff Recommendation: Meets criteria for historic designation. Forward application to Common Council.**

Staff recommends property parcel 53-05-32-413-080.000-005 (The Stancombe House) be designated as a local historic district. After careful consideration of the application and review of the Historic District Criteria as found in Ordinance 95-20 of the Municipal Code, staff finds that the property not only meets but exceeds the minimum criteria listed in the code.

The property meets Criteria 2(a) due to the distinct architectural form which is characterized as “Central Passage” with Queen Anne stylistic details.

The property meets Criteria 2(e) because the home is the only identified Central Passage home located in Bloomington. If the structure is not historically designated it will be demolished by the property owners and the last known example of this vernacular architectural form will be lost

The property meets Criteria 2(g) because it is a specific type of building form built in the United States between 1850 and 1910. This form was based on earlier vernacular building traditions that can be traced back to English colonists in the 17th century.

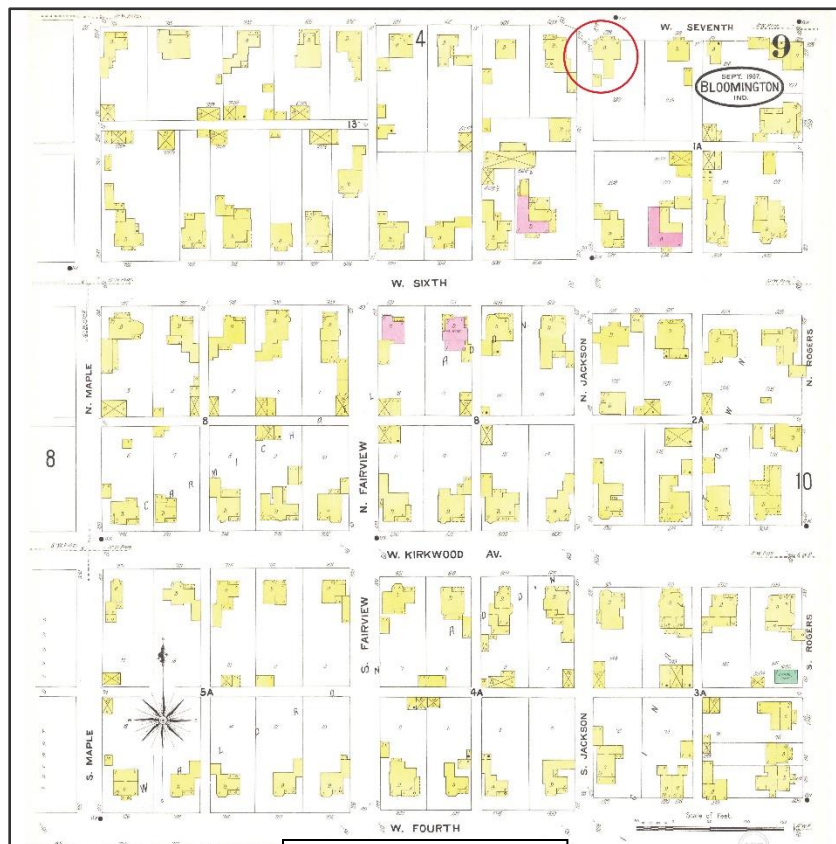

1907 Sanborn Fire Insurance Map