

# CITY OF BLOOMINGTON



October 17, 2019 @ 5:30 p.m.  
COUNCIL CHAMBERS #115  
CITY HALL

**CITY OF BLOOMINGTON  
BOARD OF ZONING APPEALS  
October 17, 2019 at 5:30 p.m.**

**◆Council Chambers - Room #115**

---

**ROLL CALL**

**APPROVAL OF MINUTES:** September 2019

**REPORTS, RESOLUTIONS, AND COMMUNICATIONS:**

**PETITIONS CONTINUED TO:** November 21, 2019

V-17-19      **City of Bloomington**  
105/111 W. 4<sup>th</sup> St., and 222 S. Walnut St.  
Request: Variances from entrance and drive standards in the Commercial  
Downtown (CD) zoning district.  
Case Manager: Jackie Scanlan

UV-26-19      **Kimberly Carballo**  
1300 S. Lincoln St.  
Request: Use variance to allow the raising of goats on a single lot in the  
Residential Core (RC) zoning district.  
Case Manager: Ryan Robling

---

**PETITIONS:**

UV/V-31-19      **Rimrock Companies**  
1901 W. 3<sup>rd</sup> St., and 307 S. Cory Lane  
Request: Use variance to allow for larger units in the 'Mini-warehouse Facility'  
use in the Commercial Arterial (CA) zoning district. Also requested is a variance  
from non-residential sign standards.  
Case Manager: Jackie Scanlan

V-38-19      **City of Bloomington**  
1649 E. Rhorer Rd.  
Request: Variance from riparian buffer requirements 20.05.041 for the purposes  
of a trail.  
Case Manager: Eric Greulich

**\*\*Next Meeting: November 21, 2019**

**Auxiliary aids for people with disabilities are available upon request with adequate notice. Please call 812-349-3429 or e-mail human.rights@bloomington.in.gov.**

**BLOOMINGTON BOARD OF ZONING APPEALS**  
**STAFF REPORT**  
**Location: 1901 W. 3<sup>rd</sup> Street / 307 S. Cory Lane**

**CASE #: UV/V-31-19**  
**DATE: October 17, 2019**

**PETITIONER:** Rimrock Companies  
 1000 Riverside Avenue, Suite 250 Jacksonville FL

**CONSULTANT:** Bynum Fanyo Associates, Inc.  
 528 N. Walnut Street, Bloomington

**REQUEST:** The petitioner is requesting use variance approval to allow for larger units than allowed in the ‘mini-warehouse facility’ use in the Commercial Arterial zoning district. The petitioner is also requesting a development variance from sign standards.

**BACKGROUND:**

<b>Area:</b>	2.93 Acres
<b>Zoning:</b>	CA
<b>Comprehensive Plan Designation:</b>	Urban Corridor
<b>Existing Land Use:</b>	Vacant/Wooded
<b>Proposed Land Use:</b>	Mini-Warehouse Facility
<b>Surrounding Uses:</b>	North - Vacant / Culver’s Restaurant
	South - Vacant / Dwelling, Single-Family (Sunset Hill)
	East - Commercial
	West - Dwelling, Single-Family

**REPORT:** The petition site is zoned Commercial Arterial (CA) and is located on the south side of 3<sup>rd</sup> Street, east of Cory Lane. Surrounding land uses include single-family residences both in the City and outside of City limits to the west; Culver’s and vacant land to the north; commercial to the east; and a vacant parcel with more single-family development outside of the City to the south. The property is currently vacant with some wooded areas and a billboard.

The petitioner proposes to develop this site with three mini-warehouse facility buildings containing 41,600 square feet of storage space, as well as a 6,000 square foot office building on the petition site. Six parking spaces are included near the office building. One 32,325 square foot mini-warehouse facility building is also planned for the County parcel to the south.

The Unified Development Ordinance allows a maximum of 200 square feet per unit in a mini-warehouse facility. The petitioner would like to have 300 square foot units. A size limit is included in the definition of mini-warehouse facility to help limit the impacts of such facilities on surrounding properties and to differentiate the use from a general warehousing use as the impacts of the two uses (mini-warehouse facility and warehousing) can be quite different. The petitioner is requesting a use variance to allow for the larger units.

The petitioner is also requesting a development variance related to freestanding signage. There is a legal non-conforming billboard located at the northeast corner of the petition site. The billboard lease is set to expire in 2020. According to a 2014 City survey, the sign is upwards of 500 square feet. The number of freestanding signs and square footage maximum are based on the amount of frontage that the parcel has on 3<sup>rd</sup> Street. The presence of the billboard prohibits any other freestanding signs for the site. The details are discussed below.

---

**PLAN COMMISSION RECOMMENDATION:** The Plan Commission reviewed the use variance request at its October 7, 2019 meeting. The Plan Commission voted 6-0 to forward the use variance request to the Board of Zoning Appeals with a positive recommendation.

---

**SITE PLAN ISSUES:**

**Proposed Use:**

The UDO defines ‘mini-warehouse facility’ as: “A structure or group of structures containing individual storage units of two hundred (200) square feet or less with access to each unit only for the storage and warehousing of personal property. Mini-warehouses do not include activities of any kind including wholesaling, retailing, servicing or repair of household or commercial goods in conjunction with storage.” The use is permitted in the CA zoning district. However, the size of this site and its adjacency to existing single-family residences causes some concern. Intensifying that use by allowing larger units than are included in the UDO definition could exacerbate the issues by allowing larger items to be stored than those that would otherwise fit in a 200 square foot unit. Larger units also increase the opportunity and likelihood that the units can be used for more intensive uses beyond the storage of personal property that is intended.

Additionally, nothing about the property is unique and the petitioner will be able to operate successfully meeting UDO requirements.

**Sign Standards:** The CA zoning district allows one (1) freestanding stand for properties with between thirty (30) and five hundred (500) feet of frontage on a public road. The petition site has roughly 355 feet. Lots with one used and at least seventy-five (75) feet of public frontage shall be allowed to have up to forty-five (45) square feet. The height maximum allowed is six (6) feet. So, the site is allowed one forty-five (45) square foot, six (6) foot tall freestanding sign. The site contains one (1) billboard that the 2014 City Billboard Inventory lists as 26 feet tall and 576 square feet per side. (Staff is attempting to verify these dimensions as they are much different than presented by the petitioner.) The sign already located on the site (billboard) far exceeds allowable freestanding signage on this site.

The petitioner does not have a contract with the billboard company. However, the billboard company does have a lease with a previous owner. That lease is still current, but runs out some time in 2020. The Department believes that a property’s sign rights cannot be sold, and then a variance received for additional sign allotment. Until such time that the billboard is removed, no additional freestanding signs can be added to the site.

The petitioner can add wall signs to the site.

---

**20.09.140 CRITERIA AND FINDINGS FOR USE VARIANCE:  
Larger Units in Mini-Warehouse Facility**

Pursuant to IC 36-7-4-918.4., the Board of Zoning Appeals or the Hearing Officer may grant a variance from use if, after a public hearing, it makes findings of fact in writing, that:

- (1) *The approval will not be injurious to the public health, safety, morals, and general welfare of the community; and*

**PROPOSED FINDING:** No injury to the public health, safety, morals, and general welfare of the community is found in the approval of the proposed larger units. However, intensification of the use by allowing larger units may have negative effects on the neighbors.

- (2) *The use and value of the area adjacent to the property included in the variance will not be affected in a substantially adverse manner; and*

**PROPOSED FINDING:** Substantial adverse impacts to the use and value of the adjacent area are found. While the redevelopment of an underutilized property typically has a positive impact on the adjacent area, allowing larger units could intensify the use on the site which may have negative impacts on the immediately adjacent residences.

- (3) *The need for the variance arises from some condition peculiar to the property involved; and*

**PROPOSED FINDING:** No peculiar condition of the property is found that requires the need for larger units than allowed by the UDO. The petitioner is proposing 41,600 square feet of dedicated storage space on the petition site and a total of almost 74,000 square feet of storage space on the combined larger site. By the petitioner's own admission, the project can go forward without the variance, indicating no need.

- (4) *The strict application of the terms of the Unified Development Ordinance will constitute an unnecessary hardship if applied to the property for which the variance is sought; and*

**PROPOSED FINDING:** Strict application of the UDO does not constitute an unnecessary hardship because the use can still occur on the site, within the bounds of the existing regulations.

- (5) *The approval does not interfere substantially with the Growth Policies Plan (Comprehensive Plan).*

**PROPOSED FINDING:** The Comprehensive Plan designates this property as Urban Corridor. The Urban Corridor area is designed to transform strip retail and commercial corridors along major roadways into a more urban mixed-use district that will serve as an appropriate transition area from higher more intensive uses to other districts, Focus Areas, and regional activity centers. The area is intended to transform the existing auto-centric context into a mixed-use district. Allowing the intensification of an already auto-centric use

does not support the goals of the Comprehensive Plan. The Plan Commission voted to forward the petition to the Board of Zoning Appeals with a positive recommendation.

---

## CRITERIA AND FINDINGS FOR DEVELOPMENT STANDARDS VARIANCE

### 20.09.130 e) Standards for Granting Variances from Development Standards (Sign):

A variance from the development standards of the Unified Development Ordinance may be approved only upon determination in writing that each of the following criteria is met:

- 1) *The approval will not be injurious to the public health, safety, morals, and general welfare of the community.*

**PROPOSED FINDING:** Injury is found with this petition. The sign number and maximum standards are in place, in part, in order to protect the landscape from visual clutter, especially along high-speed roadways where the distraction can be dangerous. The petition site contains a sign that far exceeds the allowable freestanding sign maximum square footage. One freestanding sign is the maximum allowed on the site.

- 2) *The use and value of the area adjacent to the property included in the Development Standards Variance will not be affected in a substantially adverse manner.*

**PROPOSED FINDING:** No adverse impacts to the use and value of surrounding properties as a result of the requested variance are found. Freestanding signs are utilized by other uses in the area, but within the restrictions of the UDO.

- 3) *The strict application of the terms of the Unified Development Ordinance will result in practical difficulties in the use of the property; that the practical difficulties are peculiar to the property in question; that the Development Standards Variance will relieve the practical difficulties.*

**PROPOSED FINDING:** No peculiar conditions are found at the site. The site contains a lawful nonconforming freestanding sign, and the petitioner is requesting more. The billboard on site operates under an existing lease and has been located at the location for many years. The site allows for up to 45 square feet of freestanding signage and the site already maintains more than 10 times that amount. A previous property owner entered into a contract with the billboard company which utilizes and exceeds the freestanding sign allowance for the site. There are no practical difficulties related to signage on site. The user could use the existing sign, and is also able to utilize wall signage.

---

**RECOMMENDATION:** The Department recommends that the Board of Zoning Appeals adopts the proposed findings and denies UV/V-31-19.

IN

CA

Site

PUD

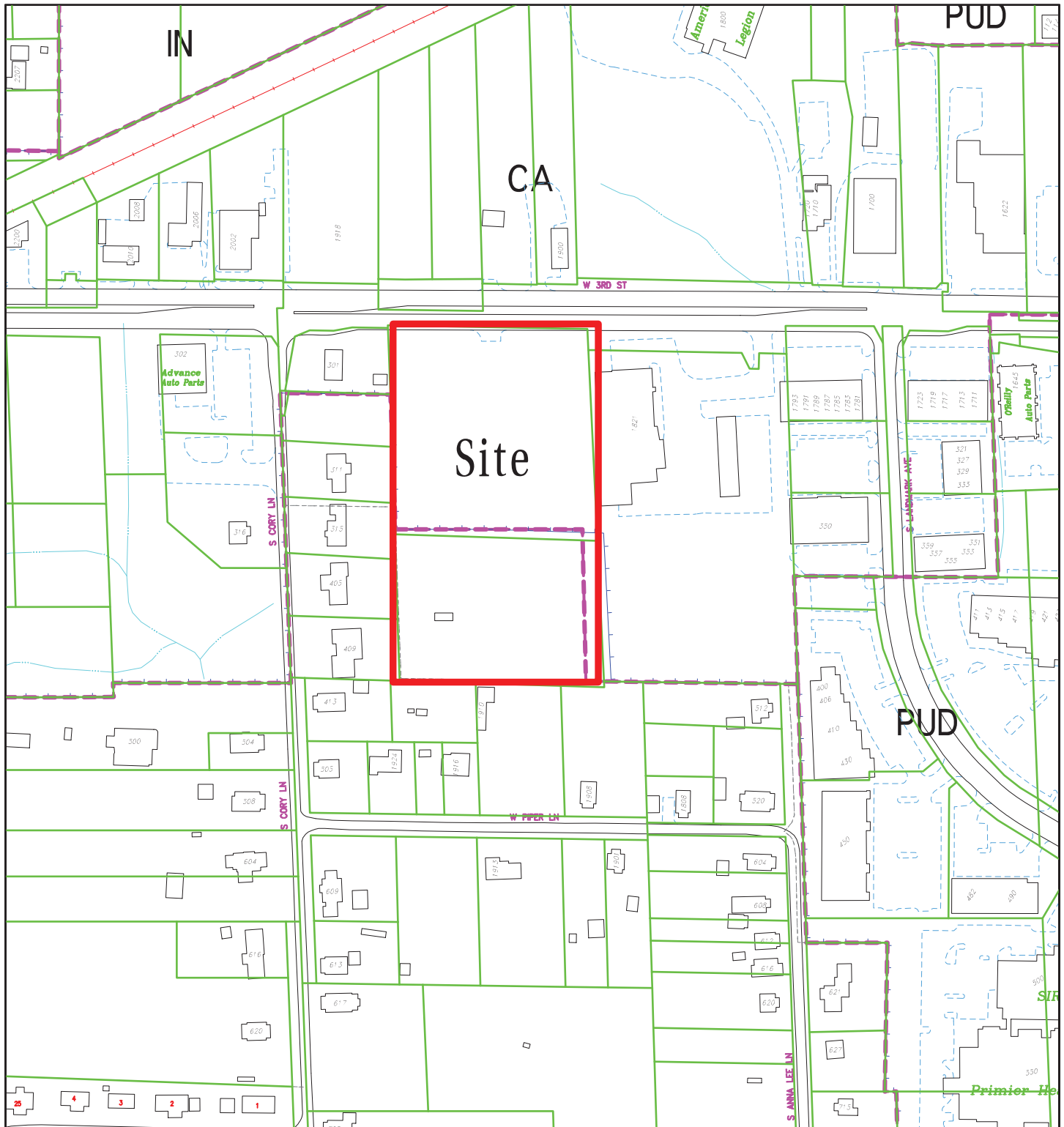

By: greulice  
21 Jun 19

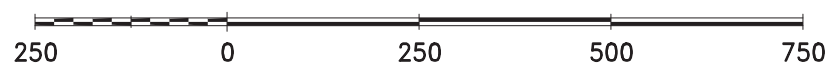

City of Bloomington  
Planning & Transportation

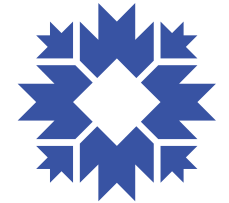

Scale: 1" = 250'

For reference only; map information NOT warranted.



By: greulice  
21 Jun 19

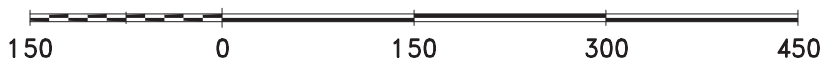

City of Bloomington  
Planning & Transportation

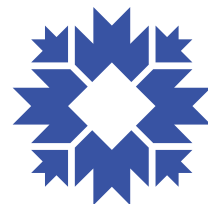

Scale: 1" = 150'

For reference only; map information NOT warranted.





BYNUM FANYO & ASSOCIATES, INC.

ARCHITECTURE  
CIVIL ENGINEERING  
PLANNING

August 26, 2019

Jackie Scanlan  
City of Bloomington Planning Department  
401 N. Morton Street  
Bloomington, Indiana 47404

RE: Rimrock Companies Self-Storage (Mini-Warehouse Facility) Site  
Final Plan Approval Petitioner's Statement

Jackie Scanlan or To Whom It May Concern:

Our client, Rimrock Companies, respectfully request final plan approval for the referenced project and to be placed on the next Plan Commission agenda for the plan to be approved by the Plan Commission members.

**Project Narrative:**

The proposed development at 1901 West 3<sup>rd</sup> Street consists of developing 4 new structures for purposes of commercial development. The commercial application will include self-storage units with an associated office space. This proposed development will also contain 6 parking spaces for parking at the office space. The total square footage for the site's structures totals approx. 45,250. We plan to treat most of the drainage within our property with a drainage pond facility at the northeast corner of the site. This location will help keep the proposed site at reasonable grading patterns to match the existing drainage patterns. The total project site is 5.50 acres (2.93 area in City of Bloomington's current planning jurisdiction). We will be working toward approvals through the Monroe County Planning Department with the other 2.57 acreage currently in the Monroe County Planning jurisdiction. The entire site is within the City's 'CA' zoning boundary.

This proposed development is proposing two (2) variances from the current UDO:

1. UDO Section 20.05.079 - Signage.
  - a. The project would like to propose signage that would adhere to the follow standards from the UDO:
    - i. Wall sign on north face of building #1- 75 square feet max.
    - ii. Wall sign on north face of building #2- 180 square feet max.
    - iii. North property line free standing sign - Allowed one sign 45 square feet max. and 6 feet in height max. (Must be located 2' min. from property line)
  - b. Existing billboard at northeast corner on site is already 160 sq. ft.
  - c. Existing billboard contract goes through 2020.

528 NORTH WALNUT STREET  
812-332-8030

BLOOMINGTON, INDIANA 47404  
FAX 812-339-2990

- d. Place new signage that would meet UDO while keeping the duration of billboard contract.
2. UDO Section 20.02.330 – Mini Warehouse max. size.
    - a. The project would like to propose 300 sq. ft. max.
    - b. The current UDO standard is 200 sq. ft. max. unit size.

After you have had a chance to review our petition please feel free to contact us at anytime questions regarding our submission.

Sincerely,  
Bynum Fanyo & Associates, Inc.

A handwritten signature in black ink, appearing to read 'Daniel Butler', written in a cursive style.

Daniel Butler, P.E., Project Engineer

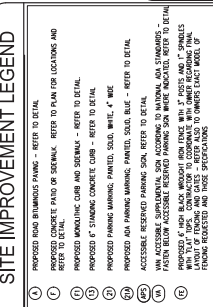
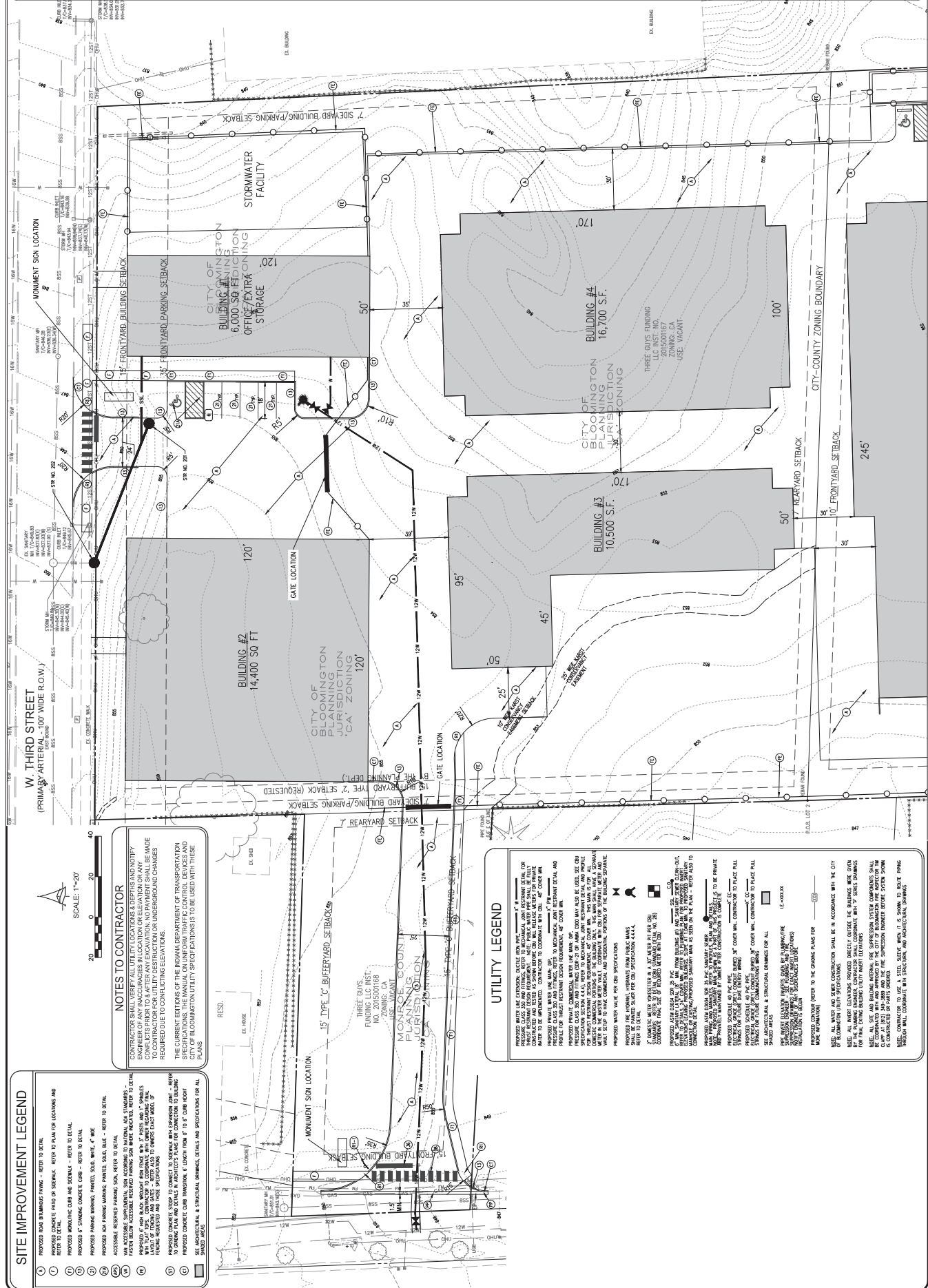

**NOTES TO CONTRACTOR**  
CONTRACTOR SHALL VERIFY ALL UTILITY LOCATIONS & DEPTHS AND NOTIFY ENGINEERS OF ANY INCONGRUENCES IN LOCATION OR ELEVATION OR ANY CHANGES TO CONTRACTOR FOR UTILITY DESTRUCTION OR UNDERGROUND CHANGES REQUIRED DUE TO CONFLICTING ELEVATIONS.  
THE CURRENT EDITIONS OF THE INDIANA DEPARTMENT OF TRANSPORTATION SPECIFICATIONS, THE MANUAL ON UNIFORM TRAFFIC CONTROL DEVICES AND PLANS, BLOOMINGTON UTILITY SPECIFICATIONS IS TO BE USED WITH THESE PLANS.

15' TYPE 'C' BUFFER YARD SETBACK  
7' REAR YARD SETBACK  
10' SIDE YARD SETBACK  
7' FRONT YARD SETBACK  
12' SIDE YARD SETBACK

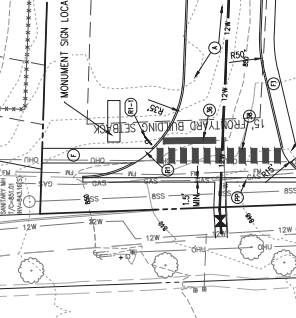

**UTILITY LEGEND**

PROPOSED WATER LINE EXTENSION...  
PROPOSED SANITARY SEWER...  
PROPOSED FIRE SUPPLY...  
PROPOSED GAS...  
PROPOSED TELEPHONE...  
PROPOSED CABLE...  
PROPOSED FIBER OPTIC...  
PROPOSED STRUCTURAL...  
PROPOSED SIGNAGE...  
PROPOSED LIGHTING...  
PROPOSED ELECTRICAL...  
PROPOSED MECHANICAL...  
PROPOSED PLUMBING...  
PROPOSED HVAC...  
PROPOSED INTERIORS...  
PROPOSED EXTERIORS...  
PROPOSED LANDSCAPE...  
PROPOSED PAVING...  
PROPOSED CONCRETE...  
PROPOSED METALS...  
PROPOSED GLASS...  
PROPOSED MASONRY...  
PROPOSED WOOD...  
PROPOSED OTHER...





REVISIONS:

**ZONING INFORMATION**

JURISDICTION: MONROE COUNTY FOR PROPERTY TO WEST AND SOUTH -  
 CITY OF BLOOMINGTON AREA & CITY OF BLOOMINGTON FOR  
 PROPERTY TO EAST AND NORTH

ZONING: COMMERCIAL, ARTERIAL (CA)

PROPOSED USE: COMMERCIAL USE, RESTAURANTS/FOOD SERVICE,  
 BUS STORAGE, 10 5000'

MAXIMUM HEIGHT: 80'

USABLE OPEN SPACE PER DWELLING UNIT: 1,000 SF

FLOOR AREA RATIO: 1.5

SIDE YARD SETBACK: 10' UNLESS OTHERWISE NOTED TO RESIDENTIAL,  
 ADD 4' FOR EACH ADDITIONAL BUILDING STORY

REAR YARD SETBACK: 10', 25' IF ADJACENT TO RESIDENTIAL

SIDE YARD SETBACK: IF ADJACENT TO NONRESIDENTIAL, THEN  
 SETBACK SHALL BE 0.05 TIMES THE LOT WIDTH, ROUNDED TO THE NEXT  
 WHOLE NUMBER, BUT NOT LESS THAN 5'. IF ADJACENT TO RESIDENTIAL,  
 MINIMUM OF 25', 10' IF ADJACENT TO RESIDENTIAL

REAR YARD SETBACK: 4', 10' UNLESS OTHERWISE NOTED TO  
 RESIDENTIAL

**EXISTING LEGEND**

- X EXISTING FENCE
- EXISTING WATER LINE
- EXISTING OVERHEAD ELECTRIC LINES
- EXISTING UNDERGROUND ELECTRIC LINES
- EXISTING UNDERGROUND TELEPHONE LINES
- EXISTING OVERHEAD TELEPHONE LINES
- EXISTING UNDERGROUND TELEPHONE LINES
- EXISTING GAS LINE
- EXISTING CONTOUR & ELEVATION
- FLOW LINE
- EXISTING MANHOLE SEWER AND  
 MANHOLE
- EXISTING STORM SEWER AND ALEET

- 1 X 14,400 S.F. = 14,400 S.F.
- 1 X 16,700 S.F. = 16,700 S.F.
- 1 X 10,500 S.F. = 10,500 S.F.
- 1 X 32,875 S.F. = 32,875 S.F.
- TOTAL = 74,925 S.F. STORAGE SPACE

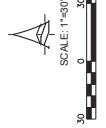

**NOTE TO CONTRACTOR**

CONTRACTOR SHALL VERIFY ALL UTILITY LOCATIONS & DEPTHS AND NOTIFY  
 ENGINEER OF ANY INCORPORATIONS IN LOCATION OR ELEVATION OR ANY  
 OTHER INFORMATION THAT MAY AFFECT THE PROJECT. CONTRACTOR SHALL  
 NOTIFY ENGINEER OF ANY UTILITY DESTRUCTION OR UNDERGROUND CHANGES  
 IMMEDIATELY TO AVOID DELAYS TO THE PROJECT.

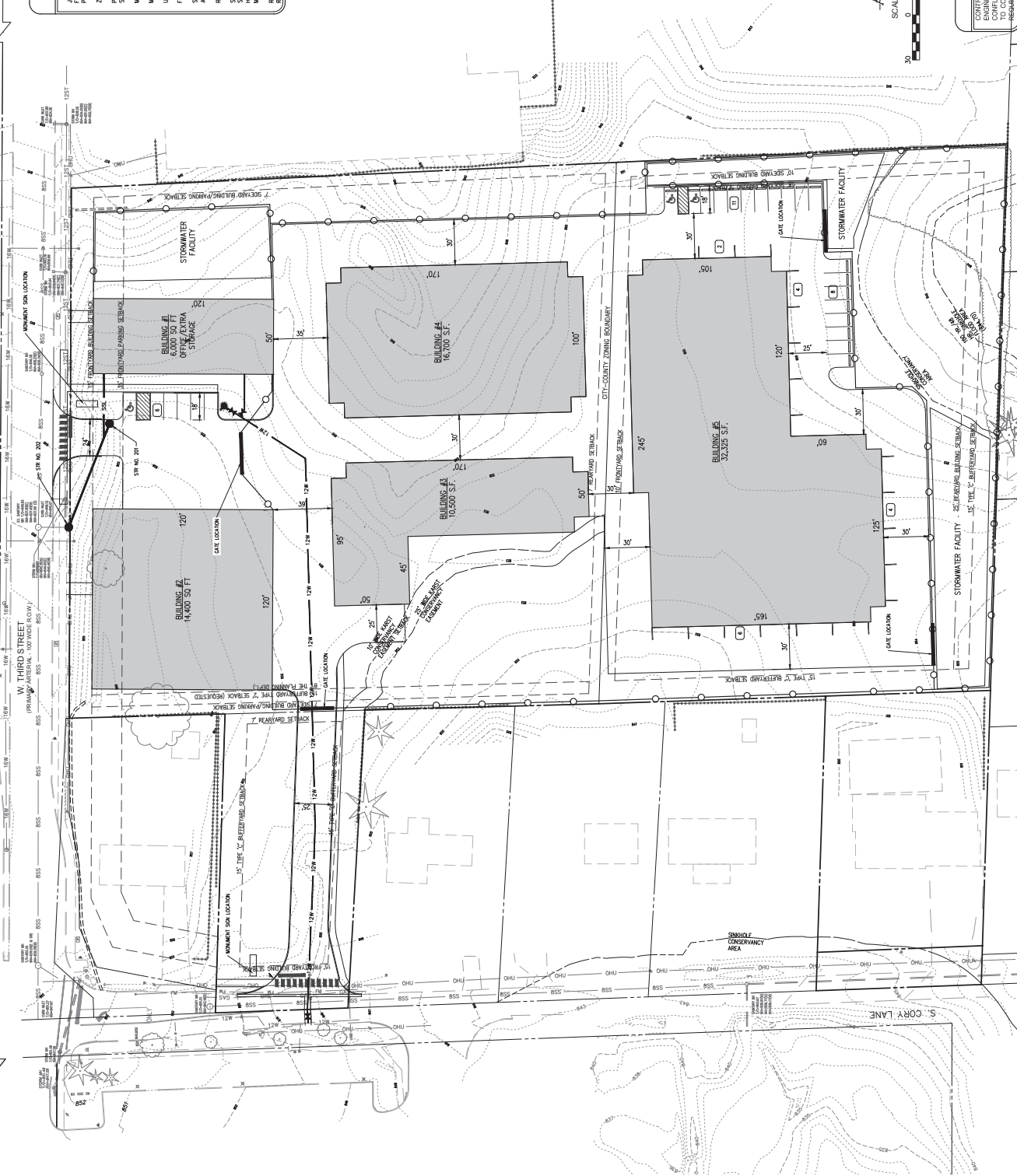

BYNUM FAYND & ASSOCIATES, INC.  
 CIVIL ENGINEERING  
 ARCHITECTURE  
 PLANNING

528 North Walnut Street  
 Bloomington, Indiana 47404  
 (317) 332-8030  
 (317) 339-2900 (fax)

certified by:

PROPOSED  
 WEST THIRD & CORY LANE  
 RIMROCK COMPANIES  
 BLOOMINGTON, INDIANA

11000 OVERALL  
 SCHEMATIC SITE  
 PLAN

13  
 designed by: DJB  
 drawn by: DJB  
 checked by: JSP  
 sheet no.: C-001  
 project no.: 161918



**SAA** architects

Client centered • Smart solutions  
August 26th 2019

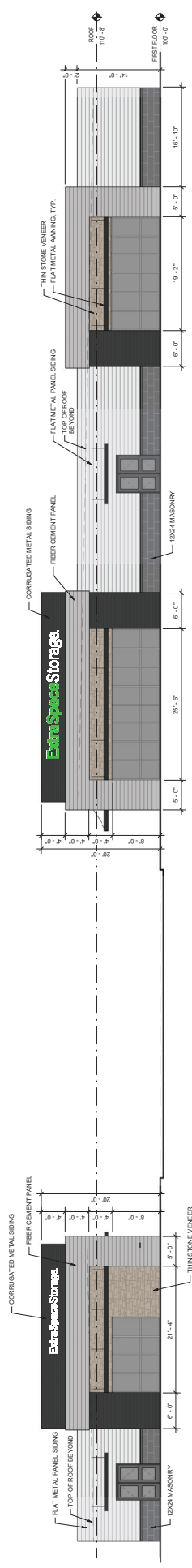

1 NORTH EXTERIOR ELEVATION - W. THIRD STREET  
 1/32" SCALE: 1/8" = 1'-0"

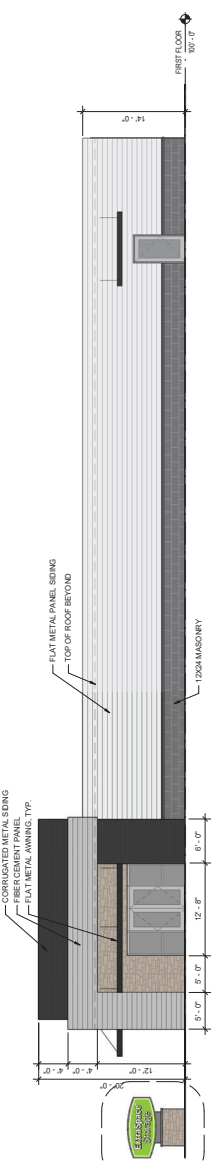

2 WEST EXTERIOR ELEVATION - BUILDING #1 - OFFICE  
 1/32" SCALE: 1/8" = 1'-0"

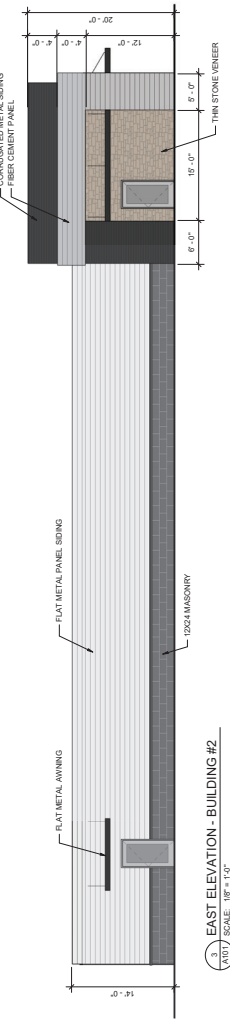

3 EAST EXTERIOR - BUILDING #2  
 1/32" SCALE: 1/8" = 1'-0"

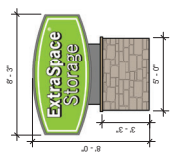

4 SIGN DETAIL  
 1/32" SCALE: 1/8" = 1'-0"

MATERIAL LEGEND

	FIBER CEMENT PANEL
	THIN STONE VENEER NONA MESSURINE
	CORRUGATED METAL SIDING
	FLAT METAL PANEL SIDING
	12X24 MASONRY

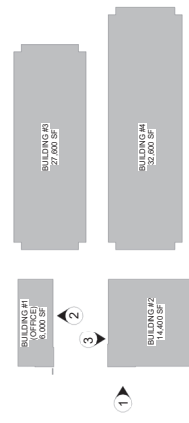

KEY PLAN

08/21/2019

15  
**SAA** architects

**A101- EXTERIOR ELEVATIONS - BUILDING #1, #2**

**BLOOMINGTON SELF STORAGE**  
 301-307 SOUTH CORY LANE  
 BLOOMINGTON, IN 47403

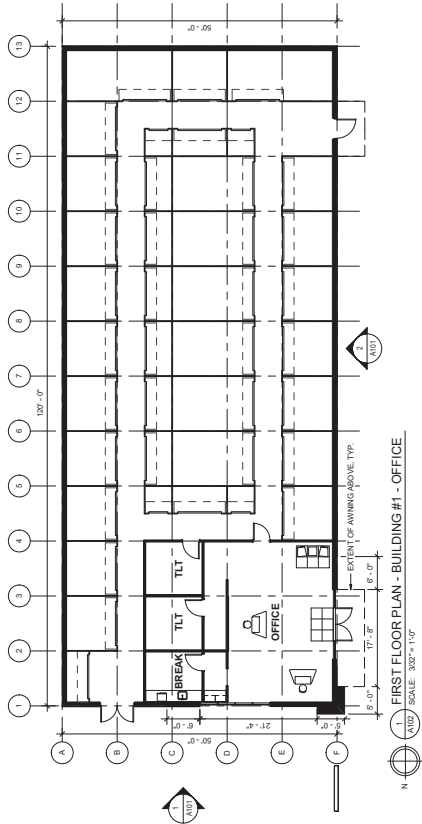

	TC	TOTAL
5x5	4	4
5x10	8	8
7.5x10	0	0
10x10	18	18
10x15	7	7
10x20	2	2
10x30	0	0
TOTAL	39	39

1 FIRST FLOOR PLAN - BUILDING #1 - OFFICE  
SCALE: 3/32" = 1'-0"

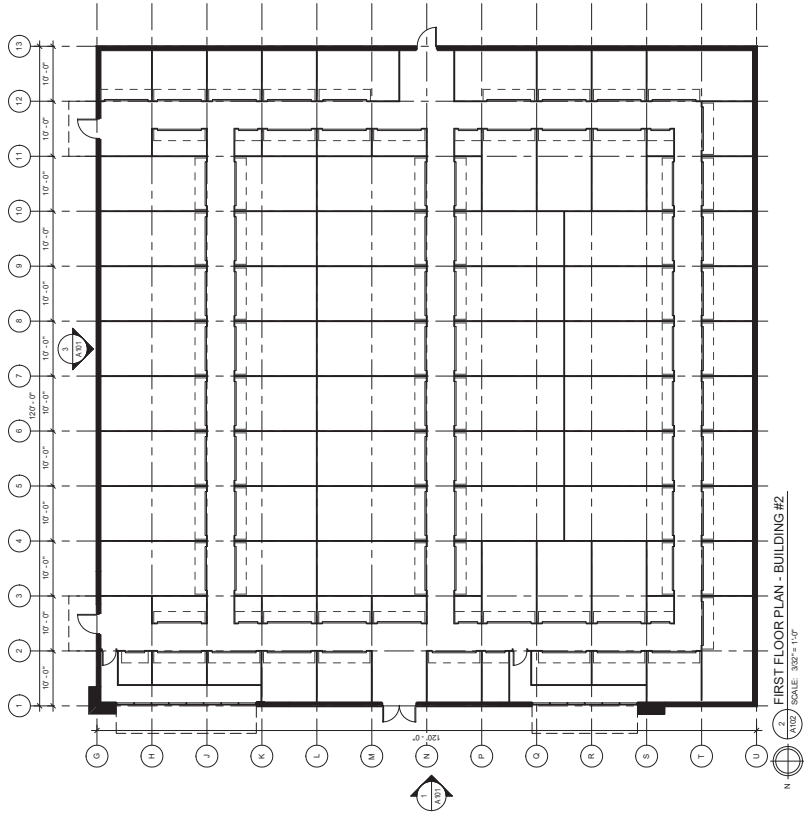

	TC	TOTAL
5x6	7	7
5x10	17	17
7.5x10	0	0
10x10	20	20
10x15	16	16
10x20	30	30
10x30	0	0
TOTAL	90	90

2 FIRST FLOOR PLAN - BUILDING #2  
SCALE: 3/32" = 1'-0"

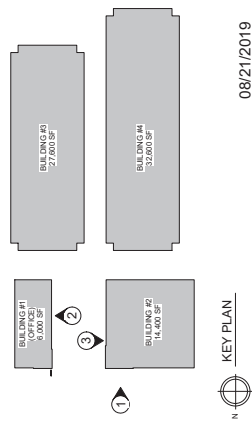

KEY PLAN

**A102 - FIRST FLOOR PLAN - BUILDING #1 & #2**



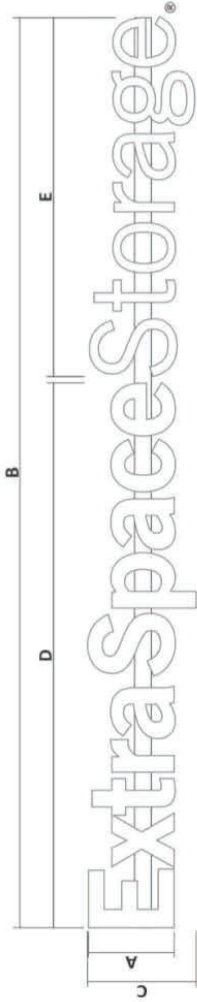

- A** MEASURED FROM OVERALL HEIGHT OF THE LETTER 'E'.
- B** MEASURED FROM OVERALL LENGTH WITH OUT TRADE MARK.

A	B	C	D	E	SQ. FT.	AMPS	NUMBER OF POWER SUPPLIES
12"	10'-7 3/4"	15 1/4"	6'-4 3/8"	4'-2 1/2"	10.65	1.26	2
18"	15'-11 3/4"	22 7/8"	9'-6 5/8"	6'-3 3/4"	23.96	1.26	2
24"	21'-3 5/8"	30 1/2"	12'-8 7/8"	8'-5"	42.60	1.26	2
30"	26'-7 1/2"	38"	15'-11"	10'-6 1/4"	66.56	1.89	3
36"	31'-11 3/8"	45 5/8"	19'-1 1/4"	12'-7 1/2"	95.84	2.52	4
42"	37'-3 1/4"	53 1/4"	22'-3 1/2"	14'-8 3/4"	130.45	2.52	4
48"	42'-7 1/8"	60 7/8"	25'-5 3/4"	16'-10"	170.37	3.78	6
60"	53'-2 7/8"	76 1/8"	31'-10 1/8"	21'-1 1/2"	266.19	5.04	8

# ExtraSpaceStorage®

## SPECIFICATION

- NON-CORROSIVE INSTALLATION HARDWARE: GALVANIZED
- 5" FABRICATED ALUMINUM LETTER RETURNS SEE MFG. NOTE FOR GAUGE. GLOSS BLACK PAINT INTERIOR WITH LIGHT ENHANCING PAINT
- TRIM CAP RETAINER DOVE GREY
- FLAT ALUMINUM BACK
- 1/4" THICK METAL FLAT BAR FOR A SECURE INSTALLATION
- US LED SV3-3-12-W
- 3/16" #7328 ACRYLIC FACE WHITE
- LOW VOLTAGE ELECTRONIC POWER SUPPLY MOUNTED IN A 7" x 4 1/2" EXTRUDED .050 ALUM. RACEWAY SUPPORT/WIRING BOX PAINTED
- VISIBLE CUT-OFF SWITCH WITH FLIP-UP COVER
- 1/4" WEEP HOLES (2) TWO PER LETTER GROUNDED WALL PASS-THRU SEALED WATER TIGHT. WHIP ON LEFT SIDE.
- 

## SECTION DETAIL

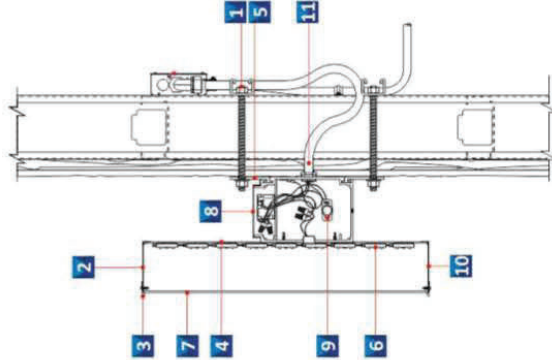

## MOUNTING DETAILS

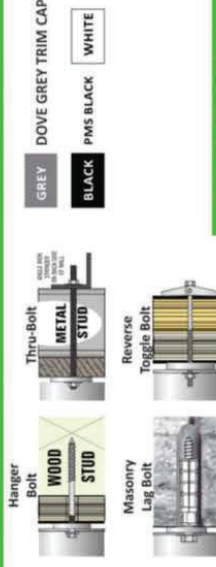

## COLOR SCHEDULE

### BRACING DETAIL

WHEN NEEDED SUPPORTS TO BE .090" ALUMINUM PAINTED TO MATCH RW POP-RIVETED TO RETURN (FACING UP TO HIDE FROM SIGHT)

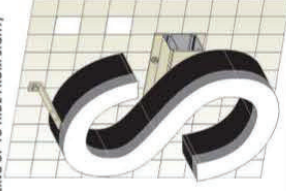

### MANUFACTURING NOTES

CHANNEL LETTER SETS SMALLER THAN 48" WILL BE CONSTRUCTED USING .040 ALUMINUM RETURNS & .063 ALUMINUM BACKS  
 CHANNEL LETTER SETS 48"-71" WILL BE CONSTRUCTED USING .063 ALUMINUM RETURNS & .090 ALUMINUM BACKS



120V CIRCUITS ARE REQUIRED FOR ALL SIGNS

FLUSH MOUNT CHANNEL LETTERS

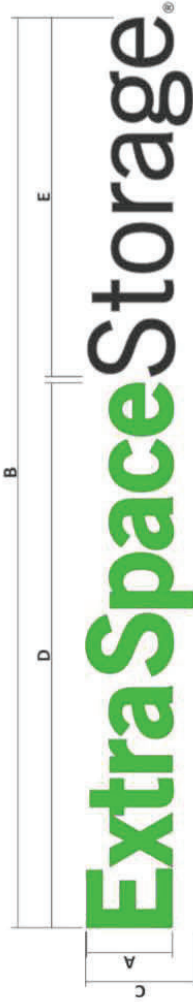

- A** MEASURED FROM OVERALL HEIGHT OF THE LETTER 'E'.
- B** MEASURED FROM OVERALL LENGTH WITH OUT TRADE MARK.

A	B	C	D	E	SQ. FT.	AMPS	NUMBER OF POWER SUPPLIES
12"	10'- 7 3/4"	15 1/4"	6'- 4 3/8"	4'- 2 1/2"	10.65	1.26	2
18"	15'- 11 3/4"	22 7/8"	9'- 6 5/8"	6'- 3 3/8"	23.96	1.26	2
24"	21'- 3 5/8"	30 1/2"	12'- 8 7/8"	8'- 5"	42.60	1.26	2
30"	26'- 7 1/2"	38"	15'- 11"	10'- 6 1/4"	66.56	1.89	3
36"	31'- 11 3/8"	45 5/8"	19'- 1 1/4"	12'- 7 1/2"	95.84	2.52	4
42"	37'- 3 1/4"	53 1/4"	22'- 3 1/2"	14'- 8 3/4"	130.45	2.52	4
48"	42'- 7 1/8"	60 7/8"	25'- 5 3/4"	16'- 10"	170.37	3.78	6
60"	53'- 2 7/8"	76 1/8"	31'- 10 1/8"	21'- 1/2"	266.19	5.04	8

# ExtraSpaceStorage®

SPECIFICATION

- 5" FABRICATED ALUMINUM LETTER RETURNS SEE MFG. NOTE FOR GUAGE. GLOSS BLACK PAINT INTERIOR WITH LIGHT ENHANCING PAINT
- TRIM CAP RETAINER DOVE GREY
- NON-CORROSIVE INSTALLATION HARDWARE: GALVANIZED
- 3/16" #7328 ACRYLIC FACE WHITE WITH 1ST SURFACE TRANSLUCENT & PERFORATED VINYL AS SHOWN
- US LED SV3-3-12-W
- FLAT ALUMINUM BACK
- 3/8" WEEP HOLES (2) TWO PER LETTER
- GROUNDED WALL PASS-THRU SEALED WATER TIGHT. WHIP ON LEFT SIDE.
- LOW VOLTAGE ELECTRONIC POWER SUPPLY LOCATED IN INTERIOR WALL AREA INSIDE A PROTECTIVE CASE BOX
- WATERPROOF FLEXIBLE CONDUIT FOR WIRING
- VISIBLE DISCONNECT SWITCH

MOUNTING DETAILS

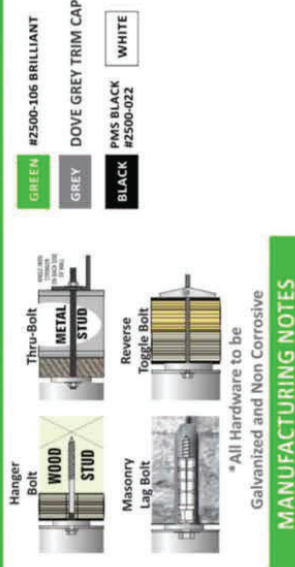

MANUFACTURING NOTES

CHANNEL LETTER SETS SMALLER THAN 48" WILL BE CONSTRUCTED USING .040 ALUMINUM RETURNS & .063 ALUMINUM BACKS

CHANNEL LETTER SETS 48"-71" WILL BE CONSTRUCTED USING .063 ALUMINUM RETURNS & .090 ALUMINUM BACKS

SECTION DETAIL

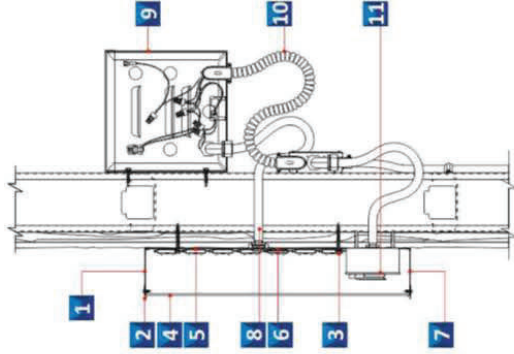

120V CIRCUITS ARE REQUIRED FOR ALL SIGNS

Sept 5, 2019

To the City of Bloomington Plan Commission Dept,

I have been a resident of Anna Lee Lane south of west 3rd street for many years, 1979. And over the years have seen some flooding, but it has grown much worse. I believe by cutting down these trees + paving over the land would only make the flooding worse in our peaceful neighborhood. And who would want the bright lights + noise at night. Please don't do this to us.

Sincerely, Barbara Bringer

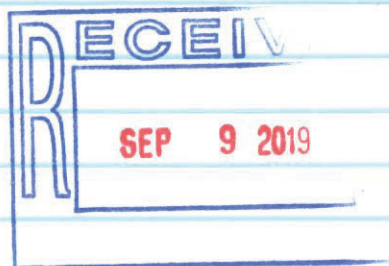

RECEIVED  
SEP - 6 2019

**City of Bloomington Plan Commission:**

**As property owners on S. Cory Ln. in Bloomington, we are greatly concerned about the proposed development by Rimrock Companies for the properties located at 1901 W 3<sup>rd</sup> St. & 307 S. Cory Ln.**

**Our property will be affected in multiple ways by this variance. Some of our concerns are privacy, security, noise, traffic and flooding. Mainly, this will cut our property by about half of what we originally were told we were purchasing when we bought here.**

**Therefore, we oppose the zoning variance proposed from Nonresidential Standards.**

Sincerely, *Wayne Shuffitt*  
*Patricia J. Shuffitt*

1808 W PIPER LN  
BLOOMINGTON, IN 47403

September 6, 2019

To Bloomington Plan Commission/Board of Zoning Appeals members:

I am a homeowner living near the properties located at 1901 W 3rd St. and 307 S. Cory Ln. on which Rimrock Companies seeks to build a "mini-warehouse facility." I and several of my neighbors have significant concerns about the proposed development and respectfully request that this use variance be denied for four specific reasons outlined within this letter.

First, for context, Indiana statute IC 36-7-4-918.4 lists five criteria which must be met, in order for a use variance to be approved.

**IC 36-7-4-918.4 Board of zoning appeals; variance of use**

Sec. 918.4. ADVISORY—METRO. A board of zoning appeals shall approve or deny variances of use from the terms of the zoning ordinance. The board may impose reasonable conditions as a part of its approval. A variance may be approved under this section only upon a determination in writing that:

- (1) the approval will not be injurious to the public health, safety, morals, and general welfare of the community;
- (2) the use and value of the area adjacent to the property included in the variance will not be affected in a substantially adverse manner;
- (3) the need for the variance arises from some condition peculiar to the property involved;
- (4) the strict application of the terms of the zoning ordinance will constitute an unnecessary hardship if applied to the property for which the variance is sought; and
- (5) the approval does not interfere substantially with the comprehensive plan adopted under the 500 series of this chapter.

As added by P.L.357-1983, SEC.13.

I believe approval of the use variance for the proposed plan by Rimrock Companies 1) would be injurious to public health, our safety, and the general welfare of the community and 2) would substantially, adversely affect both the use and value of our properties. Here's how:

•**FLOODING**—As it is, our neighborhood frequently floods—even with small amounts of rain. For your convenience, I have included photos of just a couple of areas near the would-be development with standing water due to rainfall. Additionally, many of us have septic systems. Regular, excessive flooding can damage these and can also contribute to the release of untreated wastewater into the environment.

By removing the mature trees and paving over such a large amount of nearby greenspace, our drainage issues will only worsen, potentially flooding our homes. In addition to the proposed development, we're all contending with an increase in extreme weather events, thanks to climate change.



Dr. Rich Phillips from IU's Department of Biology has worked with the Purdue Climate Change Research Center (PCCRC) and was recently quoted in "Under the Weather: How Climate Change Is Messing with Monroe County" from the April/May 2019 issue of Bloom Magazine: "Essentially, where we might only have gotten one of these [heavy rainfall] events every five or 10 years in the past, we'll get two or three of those a year."

(Continued on other side.)

•**LIGHT POLLUTION**—Those of us with properties closest to the would-be development are also concerned about bright lighting. Often, such facilities feature 12-or even 24-hour floodlighting. This would be generally disruptive—especially to our sleep. It could also decrease the resale value of our homes.

•**INCREASED TRAFFIC AND CRIME**—A nearby storage facility would also bring traffic at all hours and would be an attractive target for criminal activity. According to a 2013 ABC News feature, "Crime rates at self-storage units are on the rise. According to former FBI agent and ABC news consultant Brad Garrett, 'The locking systems are extremely poor, and the ability for people to go into them twenty-four hours a day make them ripe for people to steal items.' Further, Agent Garrett says, much of the crime does not get reported, so crime rates are likely even higher than we know and cannot truly be quantified."

•**ENVIRONMENTALLY SENSITIVE TERRAIN**—Please see the city map overlaid with karst features and natural springs at right. (The karst map itself comes from the November 2003 *City of Bloomington Environmental Resource Inventory*.)

Our neighborhood (circled in red) happens to sit on an unusually large, environmentally sensitive karst area.

Not only is this area environmentally sensitive, but it is also among some of the near-west side's last relatively pristine land. It naturally helps to slow and filter stormwater for my neighborhood, and its mature trees serve as a carbon sink in our changing climate.

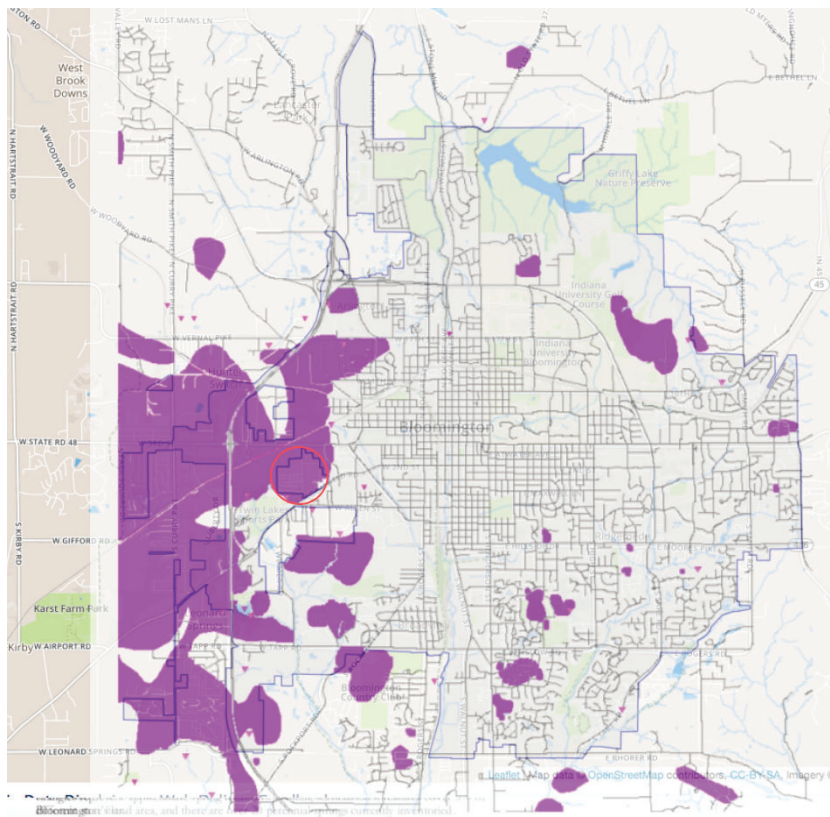

**Figure 5. Map of karst areas and springs in Bloomington and surrounding areas**  
The dark shaded areas above represent the larger karst areas in Bloomington. The shaded triangles represent approximate spring locations. Overall, surficial karst features cover 3% of Bloomington's land area, and there are over 20 perennial springs currently inventoried.

With all of this in mind, rather than grant this variance, perhaps you at the City—along with your County counterparts—should jointly acquire these parcels and re-designate them as "No Disturbance" areas instead.

Thank you for your consideration,

*Susan M. Brackney*

Susan M. Brackney

1808 W. Piper Ln.  
Bloomington, IN 47403

**BLOOMINGTON BOARD OF ZONING APPEALS**  
**STAFF REPORT**  
**Location: 1649 E. Rhorer Road**

**CASE #: V-38-19**  
**DATE: October 17, 2019**

**PETITIONER:** City of Bloomington  
 401 N. Morton Street, Bloomington

**CONSULTANT:** Butler, Fairman, & Seufert  
 8450 Westfield Blvd, Indianapolis

**REQUEST:** The petitioner is requesting a variance from riparian buffer standards to allow a 12' wide asphalt multiuse trail within the riparian buffer of Jackson Creek.

**SITE DESCRIPTION:** The petition site is located on the north side of Rhorer Road on the west side of Jackson Creek. Surrounding land uses are predominantly single family residences with the Jackson Creek Middle School on the east side of the creek. The petition site spans from Rhorer Road to Sherwood Oaks Park to the north. The property is zoned Planned Unit Development (PUD-55-87).

The City is continuing work to expand the Jackson Creek trail system based on the approved plan outlined in the Jackson Creek Trail Master Plan and the Transportation Plan. To accomplish the design outlined in those plans, there will be a new extension of the trail constructed south from Sherwood Oaks Park to Rhorer Road. The construction of the trail would involve a new 12' wide, asphalt multiuse trail. The trail would be constructed predominantly at existing grade with only minimal grading necessary for installation. The trail will be located on property owned by the Utilities Department and Parks Department along the corridor. The section of land owned by the Utilities Department is very narrow and is constrained by an existing access drive to single family residences, an underground utility line, and Jackson Creek. The petitioner has attempted to locate the new trail as far from Jackson Creek as possible, however given the narrow property width and existing constraints, it is not possible to meet the 25' riparian buffer setback required by the UDO for all of the sections of the trail.

Portions of the trail cross through the floodway and floodway fringe of Jackson Creek and a permit from the Indiana Department of Natural Resources for Construction in a Floodway is required prior to issuance of a grading permit.

The petitioner is requesting a variance from riparian buffer standards to allow a multiuse trail within the 25' wide Zone 1 area of the adjacent creek.

**CRITERIA AND FINDINGS FOR DEVELOPMENT STANDARDS VARIANCE**

**20.09.130 e) Standards for Granting Variances from Development Standards:** A variance from the development standards of the Unified Development Ordinance may be approved only upon determination in writing that each of the following criteria is met:

- 1) *The approval will not be injurious to the public health, safety, morals, and general welfare of the community.*

**PROPOSED FINDING:** No injury is found with this petition. The majority of the trail will be located outside of the Zone 1 area. The trail will improve public health by promoting alternative transportation and outdoor recreation opportunities which will greatly increase the general welfare of the community. The extension of the trail through this area was desired with the creation of the Jackson Creek Trail master plan and the recently adopted Transportation Plan.

2) *The use and value of the area adjacent to the property included in the Development Standards Variance will not be affected in a substantially adverse manner.*

**PROPOSED FINDING:** No negative effects from this proposal on the areas adjacent to the property are found. The construction of the trail will improve access of adjacent properties to the overall pedestrian network in this area. The petitioner has worked to maximize the setback from the creek and there will be minimal grading necessary to allow the construction of the trail. A heavy replanting and mitigation plan is required by the State for any trees removed which will offset any trees removed for this construction. Adjacent properties will benefit from having access to an extended multiuse trail in this area.

3) *The strict application of the terms of the Unified Development Ordinance will result in practical difficulties in the use of the property; that the practical difficulties are peculiar to the property in question; that the Development Standards Variance will relieve the practical difficulties.*

**PROPOSED FINDING:** Practical difficulty is found in that there is limited area to work within on the land owned by the City. The section of land owned by the Utilities Department is very narrow and is constrained by an existing access drive to single family residences, an underground utility line, and Jackson Creek. The petitioner has attempted to locate the new trail as far from Jackson Creek as possible, however given the narrow property width and existing constraints, it is not possible to meet the 25' riparian buffer setback required by the UDO for all of the sections of the trail. Utilizing existing city-owned property decreases the cost to taxpayers and eliminates the need to acquire private property for a public amenity. The construction of the trail will not require any substantial grading or disturbance. Peculiar condition is found in the limited amount of area along this portion of the site because of the existing driveway and amount of land owned by the Utilities Department.

---

**RECOMMENDATION:** Based upon the written report, staff recommends the Board adopt the proposed findings and approve the variance with the following condition of approval:

1. A permit from the Indiana Department of Natural Resources is required prior to any work within the floodway.



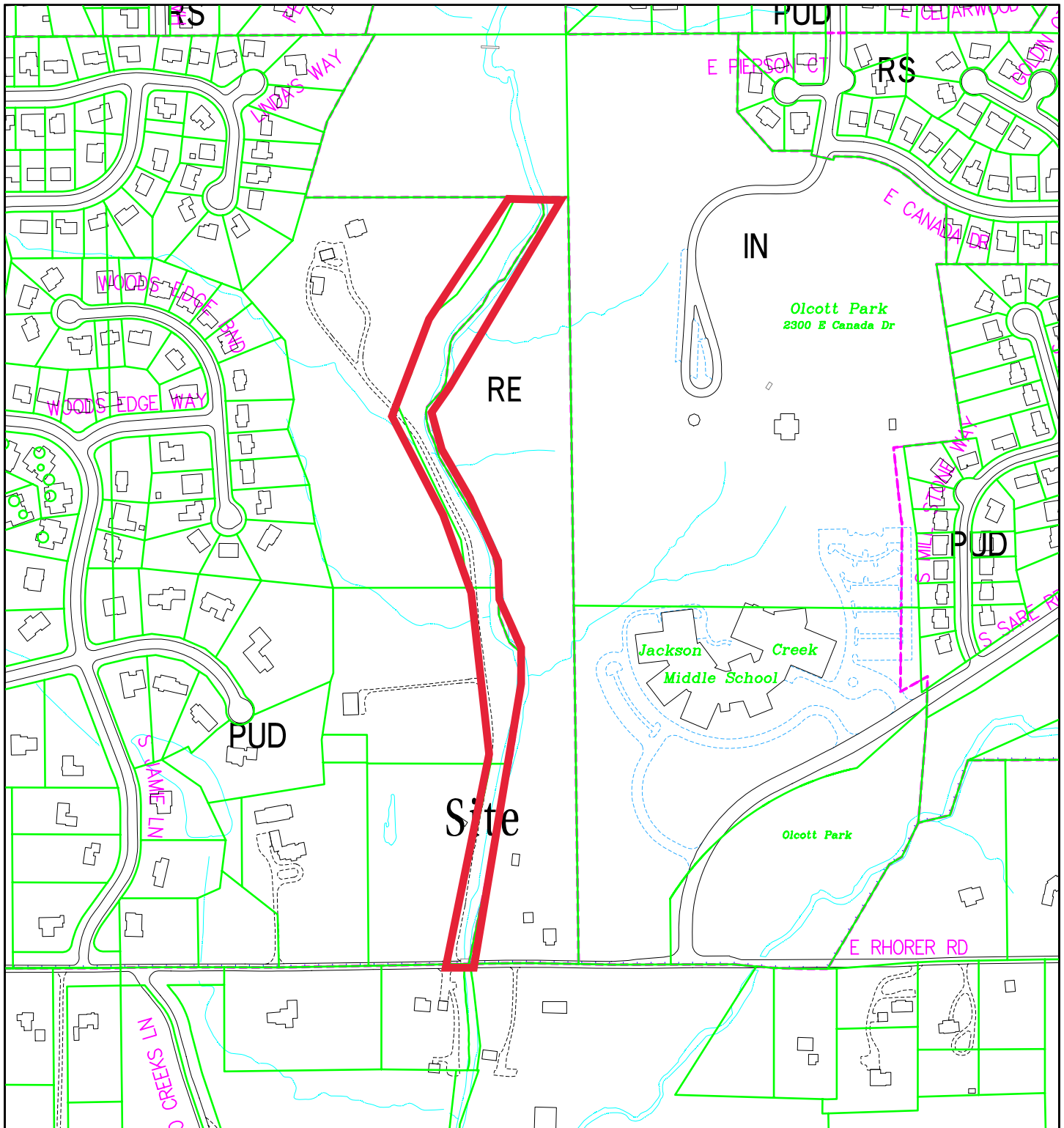

V-38-19 City of Bloomington  
 1649 E Rhorer Road  
 Board of Zoning Appeals  
 Site Location, Parcels, Zoning

By: greulice  
 11 Oct 19

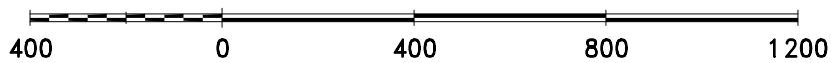

City of Bloomington  
 Planning & Transportation

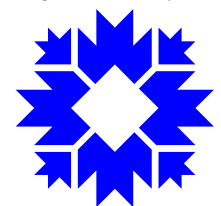

Scale: 1" = 400'

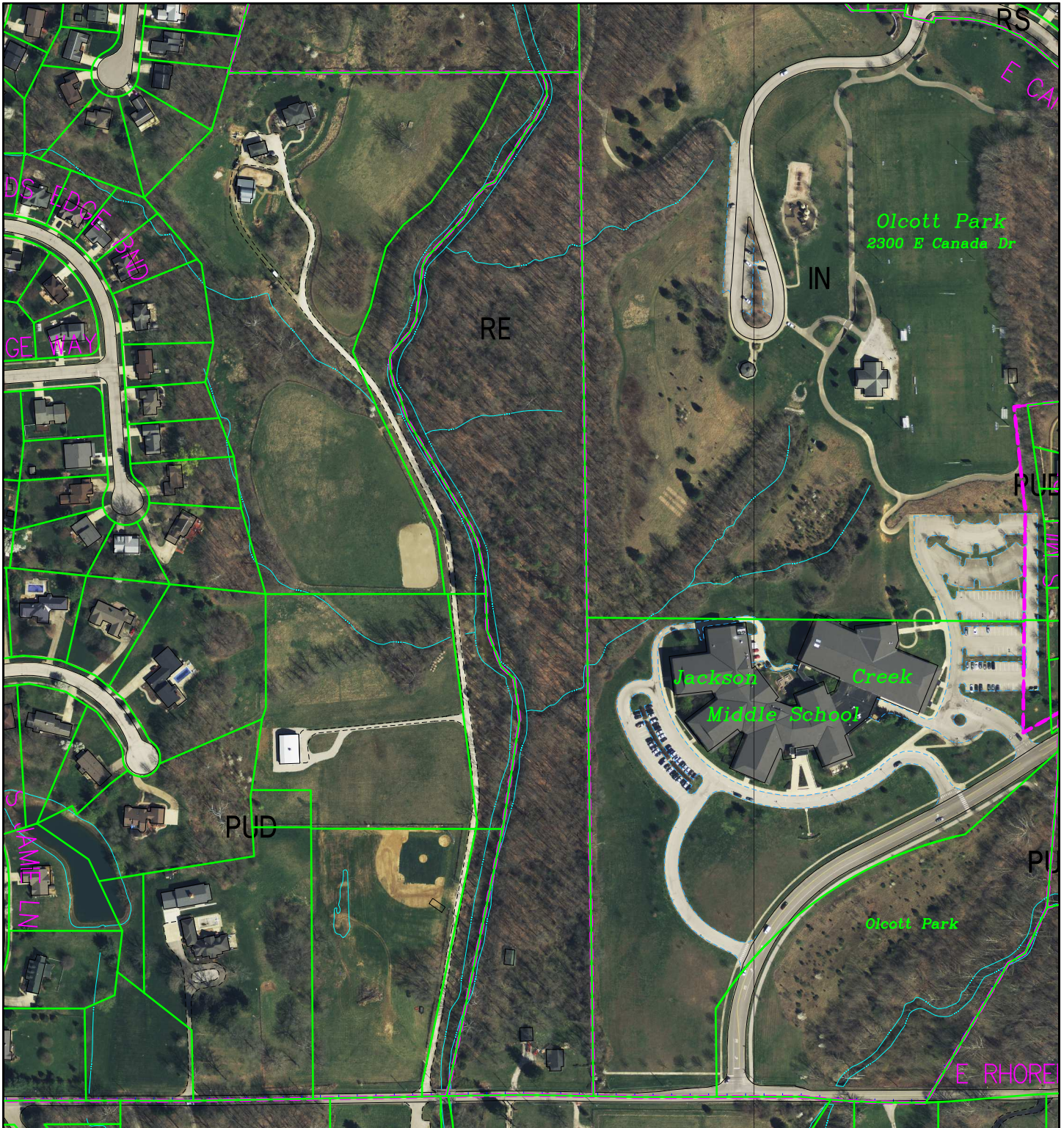

V-38-19 City of Bloomington  
 1649 E Rhorer Road  
 Board of Zoning Appeals  
 2016 Aerial Photograph

By: greulice  
 11 Oct 19

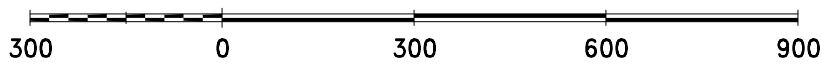

City of Bloomington  
 Planning & Transportation

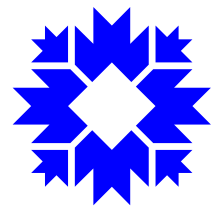

Scale: 1" = 300'

For reference only; map information NOT warranted.



**City of Bloomington**  
**Planning and Transportation Department**  
**Engineering Division**

City of Bloomington Board of Zoning Appeals  
401 N. Morton Street  
Bloomington, IN 47403

September 11<sup>th</sup>, 2019

Re: City of Bloomington Jackson Creek Trail Phase II Project  
Variance from Environmental Standards

Dear BZA Members:

The City Planning and Transportation Department is currently in the design phase for an extension of the Jackson Creek Trail. This new trail construction will start at the Sare Road multiuse path terminus at Rhorer Road, proceed westward along Rhorer Road across Jackson Creek, and then continue northward along the creek to the south end of the existing Jackson Creek Trail in Sherwood Oaks Park. A section of the new trail will be constructed on a narrow portion of City Parks Department property between an existing driveway and Jackson Creek.

On behalf of the City of Bloomington Planning and Transportation Department, we respectfully request your consideration of a variance from the Environmental Standards Section 20.05.041, Riparian Buffer of the Unified Development Ordinance.

Due to the limited availability of land and the need to accommodate this trail separated from the existing driveway, the proposed 12 ft wide asphalt trail will infringe within Zone 1 of the Riparian Buffer. The design of the trail will minimize this infringement to the maximum extent feasible while maintaining separation from vehicular facilities. The proposed trail will be constructed in an area that has been previously disturbed with the installation of a driveway, utility pole line, and sanitary sewer main.

Your positive consideration of this request is greatly appreciated.

Sincerely,

A handwritten signature in blue ink, appearing to read "Roy Aten", with a long horizontal flourish extending to the right.

Roy Aten  
Senior Project Manager  
City of Bloomington



\\s16162700.0000\Proj\Development\Design\Drawings\Exhibits\2019-09-17\Jackson Creek South - Trail - Preliminary Drawings - Volume Plot:9/17/2019 4:08 PM Show:9/17/2019 4:05 PM

# JACKSON CREEK PHASE 2





W:\16162700.0000\Proj\Development\Design\Drawings\Exhibits\2019-09-17\Jackson Creek South - Trail & Private Drive.dwg Douglas A. Mahore Plot: 9/17/2019 4:08 PM Show: 9/17/2019 4:05 PM

## JACKSON CREEK PHASE 2

