

# CITY OF BLOOMINGTON



## PLAN COMMISSION

December 14, 2020 @ 5:30 p.m.  
Zoom Meeting:

[https://www.google.com/url?q=https://bloomington.zoom.us/j/92271731937?pwd%3DM1p0MFIxVVR1a1picGtLT0pZck9udz09&sa=D&source=hangouts&ust=1607808638697000&usg=AFQjCNE\\_rhhzthQef6Op\\_MSz5CY8wSYDUw](https://www.google.com/url?q=https://bloomington.zoom.us/j/92271731937?pwd%3DM1p0MFIxVVR1a1picGtLT0pZck9udz09&sa=D&source=hangouts&ust=1607808638697000&usg=AFQjCNE_rhhzthQef6Op_MSz5CY8wSYDUw)

**CITY OF BLOOMINGTON  
PLAN COMMISSION  
December 14, 2020 at 5:30 p.m.**

<https://bloomington.zoom.us/j/92271731937?pwd=M1p0MFIxVVR1a1picGtLT0pZck9udz09>

**ROLL CALL**

**MINUTES TO BE APPROVED:** October 2020

**REPORTS, RESOLUTIONS AND COMMUNICATIONS:**

Appoint Hearing Officer

Sign Fee Amendment

**PETITIONS:**

PUD-17-20     **McDoel Business Center, LLC**

300 W. Hillside Drive

Request: Amendment to the preliminary plan and district ordinance for the Thomson PUD to allow 88 multi-family dwelling units and 21 single-family lots on Parcel E.

*Case manager: Eric Greulich*

ZO-23-20     **Bill C. Brown Revocable Trust**

3100 W. Fullerton Pike

Request: Rezone 87 acres from Planned Unit Development (PUD) to Mixed-Use Corridor (MC). Also requested is a waiver from the required second hearing.

*Case manager: Eric Greulich*

ZO-25-20     **Bill C. Brown – Trustee**

300 S. State Road 446

Request: Rezone

*Case manager: Ryan Robling*

**GIS MAP LINK:** <https://arcg.is/1qPLKO>

**\*\*Next Meeting January 2021**

**Last Updated: 12/11/2020**

**Auxiliary aids for people with disabilities are available upon request with adequate notice.  
Please call [812-349-3429](tel:812-349-3429) or e-mail [human.rights@bloomington.in.gov](mailto:human.rights@bloomington.in.gov).**



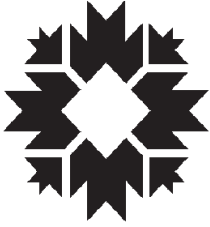

**CITY OF BLOOMINGTON  
LEGAL DEPARTMENT  
MEMORANDUM**

This memorandum may contain confidential information. If you are not the intended recipient of this memorandum, you may not read, disclose, copy, or distribute this memorandum.

**TO: Plan Commission**  
**FROM: Michael Rouker, City Attorney**  
**RE: Waiving Fees – Sign Applications**  
**DATE: December 14, 2020**

**MEMORANDUM**

As the Commission may recall, during its June 8, 2020 meeting and then again during its September 14, 2020 meeting, the Plan Commission exercised its authority under Section 20.06.040(c)(3)(E) of the Unified Development Ordinance to waive sign application fees for temporary signs (\$75 per application) and permanent signs (\$125 per application). The sign application fee waiver was part of a package of temporary measures designed to mitigate the impact of the ongoing pandemic on the Bloomington business community. The package of measures included, in addition to waiver of sign application fees, temporary road closures from the Board of Public Works to allow parklets and a relaxation of merchandising encroachment requirements from the City Council. The measures have been popular, and the response from the business community has been positive.

These proactive steps to assist our local businesses were originally put into place during the week of June 8, 2020, and were designed to sunset on September 30, 2020. In September, they were extended through December 31 of this year. As the pandemic continues, the City and business community have requested that these measures be further extended. This month, the City Council will consider a resolution to extend the relaxation of sign and merchandising encroachment requirements, and this Commission is being asked to consider a motion to further extend the waiver of sign application fees through August 6, 2021, the same date through which the Council will be asked to extend its measures.

Therefore staff respectfully requests that the Plan Commission, pursuant to its authority under Section 20.06.040(c)(3)(E) of the Unified Development Ordinance, extend the waiver of sign application fees for temporary and permanent signs through August 6, 2021.

**CBLOOMINGTON PLAN COMMISSION**  
**STAFF REPORT – Second Hearing**  
**Location: 300 W. Hillside Drive**

**CASE #: PUD-17-20**  
**DATE: December 14, 2020**

**PETITIONER:** McDoel Business Center, LLC  
 300 W. Hillside Dr., Bloomington, IN

**CONSULTANT:** Tabor/Bruce Architecture & Design, Inc.  
 1101 S. Walnut St., Bloomington

**REQUEST:** The petitioner is requesting an amendment to the preliminary plan and district ordinance for the Thomson PUD to allow 19 townhomes and 104 multi-family residences on Parcel E.

**BACKGROUND:**

**Area:** 3.7 acres  
**Current Zoning:** Planned Unit Development  
**Comp Plan Designation:** Urban Corridor and Switchyard North Focus Area  
**Existing Land Use:** Office and Warehouse  
**Proposed Land Use:** Mixed Use  
**Surrounding Uses:** North – Warehouse (Storage Express)  
 West – Single family residences (McDoel Neighborhood)  
 East – Switchyard Park  
 South – Crosley Warehouse (community center)

**CHANGES SINCE FIRST HEARING:** At the first hearing the petitioner proposed a site plan that featured a mix of multi-family residences with 88 dwelling units and 21 single family lots. The Plan Commission expressed a desire for more dwelling units on the property and urged the petitioner to pursue a site plan with more units and less single family residences. The petitioner revised the proposed site plan to remove the single family residences and is instead proposing 4 townhome buildings with a total of 19 units in the townhome buildings. In addition, the petitioner did not have full renderings for any of the proposed buildings at the first hearing. These renderings have now been prepared and submitted.

**REPORT:** The site is located at 300 E. Hillside Drive and is zoned Planned Unit Development (Thomson PUD). The petition site is at the east end of the Hillside Drive stub and includes a 2.85 acre property on the north side of Hillside Drive and a 0.85 acre property on the south side of Hillside Drive. Surrounding zoning includes the Thomson PUD to the north and south, Residential Small Lot (R3) to the west, and Mixed Use Institutional (MI) to the east. The surrounding properties have been developed with a mix of single family residences to the west, a storage warehouse to the north, Crosley Warehouse (community center) to the south, and the Switchyard Park to the east. This site has been developed with a 150,000 square foot warehouse that has a property line about 2/3 through the warehouse and a surface parking lot. The northern 1/3 of the warehouse, which is owned separately and contains Storage Express, is not part of this petition.

The petitioner is proposing to remove the southern 2/3 of the warehouse and redevelop the property north of Hillside Drive with several buildings, including a four-story, mixed-use building with 5,000 square feet of commercial space, 18 internal parking spaces, and 30 units; a five-story, mixed-use building with 2,000 square feet of commercial space, 16 internal parking spaces, and

32 units; and 4, three-story owner-occupied townhome buildings with a total of 19 units. A surface parking lot behind the units with 60 parking spaces would span all of the development north of Hillside Drive to be used by the residents. The property to the south of Hillside Drive would feature a five-story, multi-family building with 42 units and 90 internal parking spaces. The bottom two floors of the building south of Hillside Drive would be entirely parking. A 5' wide tree plot and 5' wide sidewalk from this site to Rogers Street has been shown along the north side of Hillside Drive. No sidewalk or tree plot on the south side of Rogers Street has been shown yet. The petitioner has committed that the mixed-use and multi-family buildings will be LEED silver certified. The townhome buildings will also be built to a comparable requirement. Each building will have a minimum of 15% of the units set aside for affordable housing as required by the UDO.

One of the main continuing areas for discussion with this petition has been the desired housing type, density, and building design along the Switchyard Park. Last year, at the request of the Administration, a conceptual design for the redevelopment of two large areas adjacent to Switchyard Park was envisioned by the design consultant of Switchyard Park. One of the two areas in the study was this location. The other location in that study is the area where Night Moves was located and Meineke currently exists on S. Walnut Street. The desire of the Administration was to explore redevelopment opportunities of these important properties. The study aimed to provide a guide for appropriate development that would place as many eyes as possible on the trail for security, provide optimal utilization of a public open space and park, add housing stock to the community, and provide high quality development along a major open space and trail system reflective of the City's substantial investment in the Park. The Consultant's design showed four story buildings along the entire frontage of the park with the 4<sup>th</sup> floors stepped back. The design also showed buildings directly facing the trail. A commercial component along the ground floor of the buildings is also desired to provide services to the residents, neighborhood, and trail users. The plan scaled back to two stories closer to the neighborhood to the west with a parking area along the back for further separation from the neighborhood. Although that study and conceptual design was an internal request and not a publicly approved document, it showed a design that complimented the Switchyard Park and its purpose was to envision a development that placed an appropriate design and density along the Park.

The petitioner's redesigned site plan more closely matches that document and desire to place more units along the Switchyard Park. The location of this property directly on the Switchyard Park creates an important need for architecture and interaction along the facades facing the Park and the Department feels that possible additional improvements can be made to the townhome buildings to improve the look of them along the Park façade.

---

**COMPREHENSIVE PLAN:** This property is designated as *Urban Corridor* and within the *Switchyard North Focus Area*. The Comprehensive Plan identifies several characteristics and provides land use guidance for this area.

Additional guidance specifically includes-

- The City is making a long-term investment in the Switchyard Park, and redevelopment efforts along the Park must focus on capitalizing on both the direct and indirect benefits of that commitment. These interests must serve multiple needs related to entrepreneurship, employment, single family and multifamily housing, and green building.
- Increases in residential density around the Switchyard Park are strongly supported for both market rate and sustainably affordable units.

- Secondly, locations should also utilize the underlying Land Use District designations within this chapter and apply the Transform theme for approvals.
- Optimize street, bicycle, and pedestrian connectivity to adjacent neighborhoods and other 20-minute walking destinations.
- Ensure that appropriate linkages to neighborhood destinations are provided.

One of the predominant themes throughout the Comprehensive Plan is the need to add housing stock to meet the community's housing needs. Especially housing for families and young professionals. The Comprehensive Plan is clear that areas adjacent to Switchyard Park should be planned with increased residential densities, for the benefit of a wide array of residents, not a select few.

---

### PRELIMINARY PLAN:

**Uses/Development Standards:** A specific zoning district has not been stated to govern any of the proposed buildings or lots, other than stating the MN district list of land uses shall be allowed. This must be corrected prior to the next hearing. A proposed property line is shown running through the bicycle storage building and should be adjusted, likewise with some of the proposed parking spaces. Neither the site plan nor subdivision plat are being approved at this time, only the standards that will govern those later approvals. A 14' landscaped buffer yard is shown along the west side of the development to provide a landscape buffer between this development and the single family neighborhood. No specific details or requirements have been submitted for this landscape buffer area yet and must be submitted prior to the next hearing.

**Parking, Streetscape, and Access:** The petitioner is showing a 24' wide parking aisle running through the site with perpendicular parking spaces on either side. The parking aisle connects to Hillside Drive and stubs to the north property line for future extension once the adjacent property to the north redevelops. A roundabout is shown interior to the parking area to meet Fire Department needs. There is a 5' wide sidewalk and 5' wide tree plot proposed along the north side of Hillside Drive that would connect from Rogers Street to the Park, although this is an off-site improvement, this is essential to connecting this development to Rogers Street. No sidewalk or tree plot are shown along the south side of Hillside Drive along the property frontage and must be shown. There are 4 internal pedestrian connections, including a central courtyard, shown to connect this development to Switchyard Park. Approval from the Parks Department must be received prior to any work on Park's property.

**Alternative Transportation:** This petition would be required to meet all of the standards of the UDO for bicycle parking and would require one bicycle parking space per five bedrooms. The Department encourages the petitioner to incorporate several areas of covered bicycle parking spaces along the Park frontage for the residents of the development.

**Architecture/Materials:** Renderings of all of the proposed buildings have been submitted and are included in the packet. The Department believes that additional improvements can be made for the portions of the townhome buildings facing the Switchyard Park. Additional renderings were submitted after the revision deadline that show balconies along the trail and better entrance design, however the Department wants to insure a high level of design and pedestrian interaction along the Park facades. Another concern of the Department is the bottom two floors of the building proposed south of Hillside Drive. The bottom two floors of that building consist entirely of parking

with no active ground floor use, especially along the Park façade. This should be modified to include a different use along the trail façade. A brief description of the exterior finishing materials has been listed, however this list should be amended to specifically state what the approved exterior finishing materials are and to prohibit EIFS as a primary material.

**Environmental Considerations:** There are no known environmental constraints on this property.

---

**CONCLUSION:** The Department has concerns regarding the current design of the petition, specifically the sections of the townhomes facing the Switchyard Park and the ground floor of the building on the south side of Hillside Drive. The Department has reiterated multiple times the need for improvement to the rules for the interface of buildings at this location, adjacent to the B-Line. The facades facing the trail should look like front entrances, not after thoughts, as we have seen done successfully in other development along the B-Line. While there have been substantial improvements made to the petition since the previous hearing, some additional work is needed to improve the buildings as noted before making a recommendation to the Council. In addition, design standards must be included in the district ordinance to govern setbacks, building materials, and building design.

---

**RECOMMENDATION:** The Planning and Transportation Department recommends that the Plan Commission forward this petition to the January 11, 2021 hearing.



City of Bloomington  
Bloomington Environmental Commission

## MEMORANDUM

Date: August 10, 2020  
To: Bloomington Plan Commission  
From: Bloomington Environmental Commission  
Subject: PUD-17-20: W. Hillside Warehouse redevelopment  
300 West Hillside Drive, Tract E of Thomson PUD

---

The purpose of this memo is to convey the environmental concerns and recommendations for conditions of approval from the Environmental Commission (EC) with the hope that action will follow to enhance its environment-enriching attributes. The request is to amend the Preliminary Plan and District Ordinance for the Thomson PUD to allow 88 multi-family dwelling units and 21 single-family lots.

The EC applauds the Petitioner for requiring all structures in this PUD to be designated LEED for homes and LEED silver (the lowest) rating for the commercial buildings. Redeveloping this much of a neighborhood using these requirements is what the citizens of Bloomington want to see for our environmental sustainability. However, we do not think it should come at the expense of losing so much potential greenspace. Greenspace is an important ecosystem service that is part of the city's infrastructure portfolio. Given there is little an individual town can do to combat the climate crisis, planting more native vegetation, especially trees, is something we can, and should do.

As much as the EC supports the LEED construction requirements, we question supporting housing within an established neighborhood with so little greenspace.

### Comments

#### 1.) LANDSCAPE PLAN

A Landscape Plan including street trees should be designed at this point in the process so that City staff and the Plan Commission can envision the ecosystem services and aesthetics that will result at completion. The Landscape Plan will have to be approved prior to the issuance of a grading permit.

## 2.) LOT CLARIFICATION

The Thomson PUD amendment zoning rules are confusing because the first amendment addresses lots 3 through 33. Yet the second amendment heading shows lots 15 through 33. Please clarify and correct this confusion.

## 3.) IMPERVIOUS SURFACE COVERAGE

The proposed amendments for the single-family homes (lots 3–23) calls for lot sizes almost half the size as the minimum size the UDO R4 Zoning District allows. The UDO minimum is 4,000 square feet and the PUD District Ordinance revision calls for 2,100 sq. ft. The setbacks in the UDO are 15 ft. for the front yard and 25 ft. for the back yard, while the DO calls for 0 setbacks for both the front and back yards. They also propose to reduce the impervious surface percentage by 10%. The EC believes these lots are too small and the structures will be too big for the lots to accommodate single family homes. The EC is in favor of compact urban form, and that is what the newly revised UDO has accomplished; however, these setbacks don't allow sufficient greenspace.

The second amendment for residential lots 15–33, also using UDO R4 zoning standards, calls for the lots to be 2,700 sq. ft. while the UDO requires 4,000 sq. ft. The front setback is proposed to be 5 ft. instead of 15 ft. and the rear setback is 0 ft. instead of 25 ft. Impervious surface is again 10% more than the UDO allows.

The third amendment for Commercial Lots 1 and 24 proposes a 0 ft. setback where the UDO calls for 15-25 ft., and the rear setback recalls for 0 ft. and the UDO requires 7 ft. The impervious surface request is for 10% more than the UDO, and the 20% landscaped area does not add up to 100%.

## **Recommended Conditions of Approval**

The EC recommends that the following list be included as conditions of approval.

- 1.) Provide a Landscape Plan at this point in the review process, but it will not need to be approved until the issuance of a grading permit.
- 2.) Clarify and correct the conflicting proposals in the Thomson PUD amendment zoning rules.
- 3.) Increase the pervious surface, otherwise called greenspace or landscaped areas, and reduce the amount of impervious area in all areas of the site.



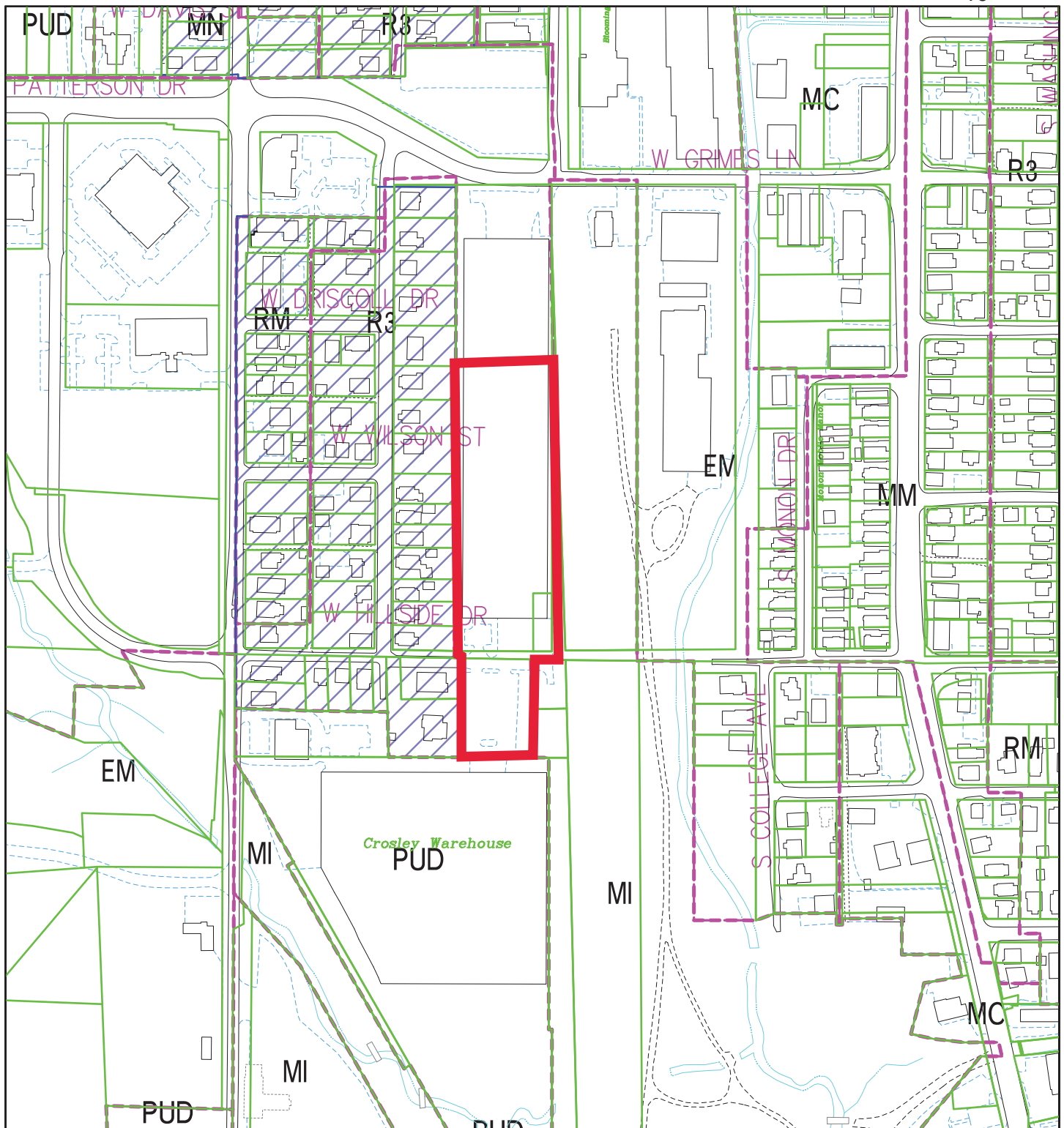

By: greulice  
11 Dec 20



City of Bloomington  
Planning & Transportation

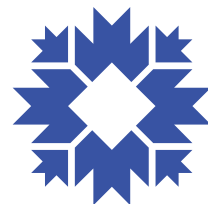

Scale: 1" = 300'





By: greulice  
11 Dec 20



For reference only; map information NOT warranted.



City of Bloomington  
Planning & Transportation



Scale: 1" = 300'





## **Thompson PUD Narrative**

### **300 West Hillside Drive Tract E-Thompson PUD**

#### **Overview-Existing site**

The site as it exists, is a large industrial use site with access only from Hillside drive along it's south border. The parcel is 208 ft x 618 ft or 2.95 acres in size, and a .7 acre site currently entirely paved as a parking lot. The North parcel currently contains a single story steel building that was long used as a warehouse with loading docks, while the rail yard was used as a hub for the RCA TV manufacturing facility.

Currently, the structure is used as a mixed-use industrial complex for storage, warehousing and light manufacturing. It has some office spaces and is bordered at its north portion by a self-storage business, located on a separate parcel that is not a part of this PUD request.

#### **Location**

The location of this site and the changes that have occurred adjoining it, are the reasons for bringing this PUD request forward. The initial purchase by the city of Bloomington and the conversion of the rail yard into the city's largest park, with a new future, have not only made the redevelopment of this site feasible, but necessary. The city's investment in the new Switchyard park has changed forever, the need to have an industrial or warehouse use at this site. The entire western border of the site borders on many existing, small scale, single family homes. No connections to any existing city blocks exist along this western border. The site is adjacent to the McDoel Gardens historic district, a district consisting of a diversity of home sizes and styles. The site is the last few remaining sites, not in a flood plain, that a mixed-use community may be built along the new Switchyard park and the B-Line trail. This is an ideal location for a new, walk-able neighborhood, away from the traditional student housing and connected to the park.

#### **Changes not foreseen in the initial Thompson PUD**

The Thompson PUD was created to keep a healthy balance of industrial uses within Monroe County and a way to ensure it remained where we had access to rail service and even a newly constructed Patterson Drive, which was created to connect this warehouse and truck traffic, to highway 37 for better access to these industrial uses. Residential uses were not included within this PUD because they were not seen as compatible with the industrial uses and their needed warehouses and rail yard. All of this changed when the RCA (Thompson Consumer Electronics) plant was closed and removed, and the park idea was generated as a new use. Like that change from rail to a park, this change from warehouse, to residential just makes sense.

## Key PUD Attributes

### Architectural Character

While it is important that the new uses be compatible with the traditions exhibited by vernacular rail yard structures, the larger commercial structures will be a more modern interpretation of these building archetypes. These structures will be of larger sized brick masonry veneers, metal and cement board panels, and large, metal framed windows to imitate older building styles. The residential town home structures on lot 3 (Buildings 3,4,5,6) will be of similar style and materials to the mixed-use apartment structures with smaller scale brick veneers, cement board panels and siding.

### Uses

Commercial spaces will be provided at a portion of the ground floor of the two larger, mixed use structures with residential apartments on the upper floors. Some parking will be provided within these mixed use buildings, along with some on-street parking. These commercial spaces will be the closest commercial spaces to Switchyard park and should be uses that complement the park visitor's experience. The neighborhood will be a mix of apartment structures and owner occupied town homes. First floor uses shall be those uses as allowed in the MN requirements in the UDO. This site is the closest site to Switchyard park for access to small scale retail services, so it is hoped that smaller square foot ground floor spaces will provide amenities for both users of the park and the existing neighborhood.

### Site

A new, two-way street will connect the south end of the site to Hillside Drive for parking and access to the site and act as part of a buffer between the existing residential homes along South Madison Street. This buffer will also have a 14 foot bufferyard. Currently, the existing warehouse sits within 2 feet of the west existing property line, with no real buffer yard. The access drive will have a potential for extension to the north parcel for future connectivity if that lot were to be developed at a future time. The new site plan is also designed for a future pedestrian path to connect near West Wilson Street, if a connection would be possible in the future to allow for neighborhood access to the park. Within lot 3, will be a large green space of over 70 feet in width, that will act as a main connector from this development to the park and as a landscaped rain garden. Two other large paths will connect the park to this development and vice versa, to provide access to the B-line and the community connectivity of our linear park system.

### Mass, Scale and Form

The project is a medium scale density and structures. Building heights will vary as they do in Downtown Bloomington and yet there will be a strong sense of similarity in scale, through the use of banding and materials. Setting upper floors back from the building front along the park will also contribute to a visual reduction in height.

The residential Town home structures, with smaller footprints, will be three stories, and are orientated to project their short facade along the park and allow for more views from each unit into the park and keep the site from presenting itself as a long wall of structures. This will allow for a better connectivity through the site to the park.

## **LEED requirements**

The residential Town home single family units will require all units to meet the LEED for homes designation with items such as:

- Heat Island effect
- Rainwater management
- Non-toxic pest control
- Water efficiency
  - Outdoor water
  - Indoor water
- Minimum energy performance
- Energy Monitoring
- Homeowner education
- Annual energy use
  - Solar panels
- Efficient hot water distribution
- HVAC systems
- Materials and resources
  - Durable materials
  - Recycled content
- Construction waste management
- Material efficient framing
- Indoor environmental quality
- Solar compatibility
- Heat Island effect-Roofing
- Ventilation
- Radon resistant construction
- Air filtering
- Low emitting products

The commercial structures will also require at a minimum, LEED Silver designations and many of the LEED for homes requirements as well as other more detailed requirements.

This will include at a minimum:

- Green roofs and rooftop Solar Panels
- Rainwater management
- Minimum energy performance
- Energy efficient HVAC and plumbing systems

## **Affordability**

The multifamily structures would provide at a minimum, 15% of the apartment units as affordable units per the City of Bloomington's definition and requirements as defined in the UDO. This would also include a total of 3 of the Town home units. (15% of the 19 townhome units). The south parcel is proposed to be Senior or affordable housing, or apartments as well and 15% of those units or 7 of the proposed 42 units, will be designated affordable as well.

## Site Breakdown

### Lot 1 structure

4 stories (1 grade level parking/commercial level-3 residential stories)  
 14,300 sq feet footprint  
 24- Two bedroom units  
 6- One bedroom units  
 54 total bedrooms  
 30 total units  
 5 units affordable per city requirements  
 5,000 sq ft available, ground floor commercial space  
 18 total parking spaces within building  
 Parking available maximum 34 spaces = .62 ratio

### Lot 2 structure

5 stories (1 grade level parking/Commercial level-4 residential stories)  
 10,000 sq feet footprint  
 24-Two bedroom units  
 8-One bedroom units  
 56 total bedrooms  
 32 total units  
 5 units affordable per city requirements  
 2,000 sq ft available, ground floor commercial space  
 16 total in-building parking spaces  
 Parking available maximum 33 spaces = .58 ratio

### Lot 4-South Hillside structure

.7 acres  
 5 stories (2 grade level parking levels-3 residential stories)  
 21,600 sq feet footprint  
 39-Two bedroom units  
 3-One bedroom units  
 81 Total bedrooms  
 7 units affordable per city requirements  
 90 total in-building parking spaces  
 Parking available maximum 90 spaces = 1.10 ratio (Parking available for commercial uses and 20 spaces are reserved to Storage Express per a use agreement).

### Residential Town home lot 3 (19 total units)

3 story-single family Town homes (Owner occupied)  
 785 sq ft footprint (2,400 sq ft total unit-each)  
 Each Town home has a maximum of 4 bedrooms  
 Total 19 units and 76 bedrooms  
 Parking available maximum 31 spaces = .40 ratio

Our vision, and even outlined in the existing Thompson PUD, is to “minimize negative land use impacts on adjacent residential properties”, and “increase the viability of the PUD and its industrial component by providing office, retail, AND RESIDENTIAL USES. The existing PUD does not reduce truck traffic along Hillside Drive. The existing PUD does recognize that Tract E is adjacent to a core neighborhood and will require special design challenges if the use changes-it is this very reason we feel that the plan as presented meets and enhances the existing PUD as well as the adjacent McDoel neighborhood. No other development has the ability to provide the community access, diversified housing types, or affordable entry into home ownership as this proposal along the B-Line and Switchyard park. Our proposal with affordable homes, apartments, commercial uses, and green design, is an appropriate mix that will encourage investment and home ownership. This development will provide an attractive landscape along the edge of the park and respect the homes that border it to the west.

Thank you for your consideration.

---

Doug Bruce NCARB-LEED AP  
TABOR/BRUCE ARCHITECTURE & DESIGN, Inc.  
1101 S Walnut Street  
Bloomington, IN 47401  
(812) 332-6258

## Thompson Tract E PUD amendment zoning rules

### Commercial Lot 1-Building 1

Utilizing MM-Mixed-Use Medium Scale zoning district

Changes to the following:

Impervious surface coverage (maximum) 90%

Landscape area (minimum) 10%

Primary structure height G (maximum) 65 feet or 5 stories

Low slope roofs allowed with parapets

No minimum vehicle parking requirements

Surface parking lots minimum 14 foot buffer yard from adjacent residential units.

Neighborhood transition zoning does not apply

20.02.060 Overlay district requirements to be met

(2) Building entrances

(5) Upper floor setbacks. Any facade along the B-Line trail, above the 4<sup>th</sup> story, shall set back a minimum of 5 feet.

(6) Windows and doors on the primary facade. 60% required for first floor facing the B-Line trail and a public street.

(7) Primary Entrances. Meet UV, DE, DS, DT Standards.

(8) Facade articulation. Meet the requirements for (B). Require minimum offset depth of 4 feet.

(9) Facade materials. Prohibited materials. Vinyl, Highly reflective, wood, smooth or split faced concrete block.

Allowed uses (upper floors only)

Multifamily apartments

Allowed commercial uses (Ground floor only) per 20.02.020 Table for MN including parking within the ground level floor of the building.

## Commercial Lot 2-Building 2

Utilizing MM-Mixed-Use Medium Scale zoning district

Changes to the following:

Impervious surface coverage (maximum) 90%

Landscape area (minimum) 10%

Primary structure height G (maximum) 65 feet or 5 stories

Low slope roofs allowed with parapets

No minimum vehicle parking requirements

Surface parking lots minimum 14 foot buffer yard from adjacent residential units.

Neighborhood transition zoning does not apply

20.02.060 Overlay district requirements to be met

(2) Building entrances

(5) Upper floor setbacks. Any facade along the B-Line trail, above the 4<sup>th</sup> story, shall set back a minimum of 10 feet.

(6) Windows and doors on the primary facade. 60% required for first floor facing the B-Line trail and a public street.

(7) Primary Entrances. Meet UV, DE, DS, DT Standards.

(8) Facade articulation. Meet the requirements for (B). Require minimum offset depth of 4 feet.

(9) Facade materials. Prohibited materials. Vinyl, Highly reflective, wood, smooth or split faced concrete block.

Allowed uses (upper floors only)

Multifamily apartments

Allowed commercial uses (Ground floor only) per 20.02.020 Table for MN including parking within the ground level floor of the building.



**LOT 3-Townhome buildings 3-4-5-6 (19 units total in 4 buildings)**

Utilizing RM-Residential Multifamily zoning district

Changes only to the following:

Setbacks

Front 5 feet minimum

Rear 10 feet Minimum

Side yard 8 feet Minimum

No garage or carport allowed

Surface parking lots minimum 14 foot buffer yard from adjacent residential units.

Impervious surface coverage (Maximum) 60%

Allowed uses:

Dwelling Multi Family units (Townhomes) allowed. Maximum number of units for Lot 3, 20 units. per 20.03.030 Residential uses

**Commercial Lot 4-Building 7**

Utilizing MM-Mixed-Use Medium Scale zoning district

Changes to the following:

Impervious surface coverage (maximum) 90%

Landscape area (minimum) 10%

Primary structure height G (maximum) 65 feet or 5 stories

Low slope roofs allowed with parapets

No minimum vehicle parking requirements

Neighborhood transition zoning does not apply

20.02.060 Overlay district requirements to be met

(2) Building entrances

(5) Upper floor setbacks. None required.

(6) Windows and doors on the primary facade. 60% required for first floor facing a public street.

(7) Primary Entrances. Meet UV, DE, DS, DT Standards.

(8) Facade articulation. Meet the requirements for (B). Require minimum offset depth of 4 feet.

(9) Facade materials. Prohibited materials. Vinyl, Highly reflective, wood, smooth or split faced concrete block.

Allowed uses (upper floors only)

Multifamily apartments

Allowed commercial uses (Ground floor only) per 20.02.020 Table for MN including parking within the ground level floor of the building.

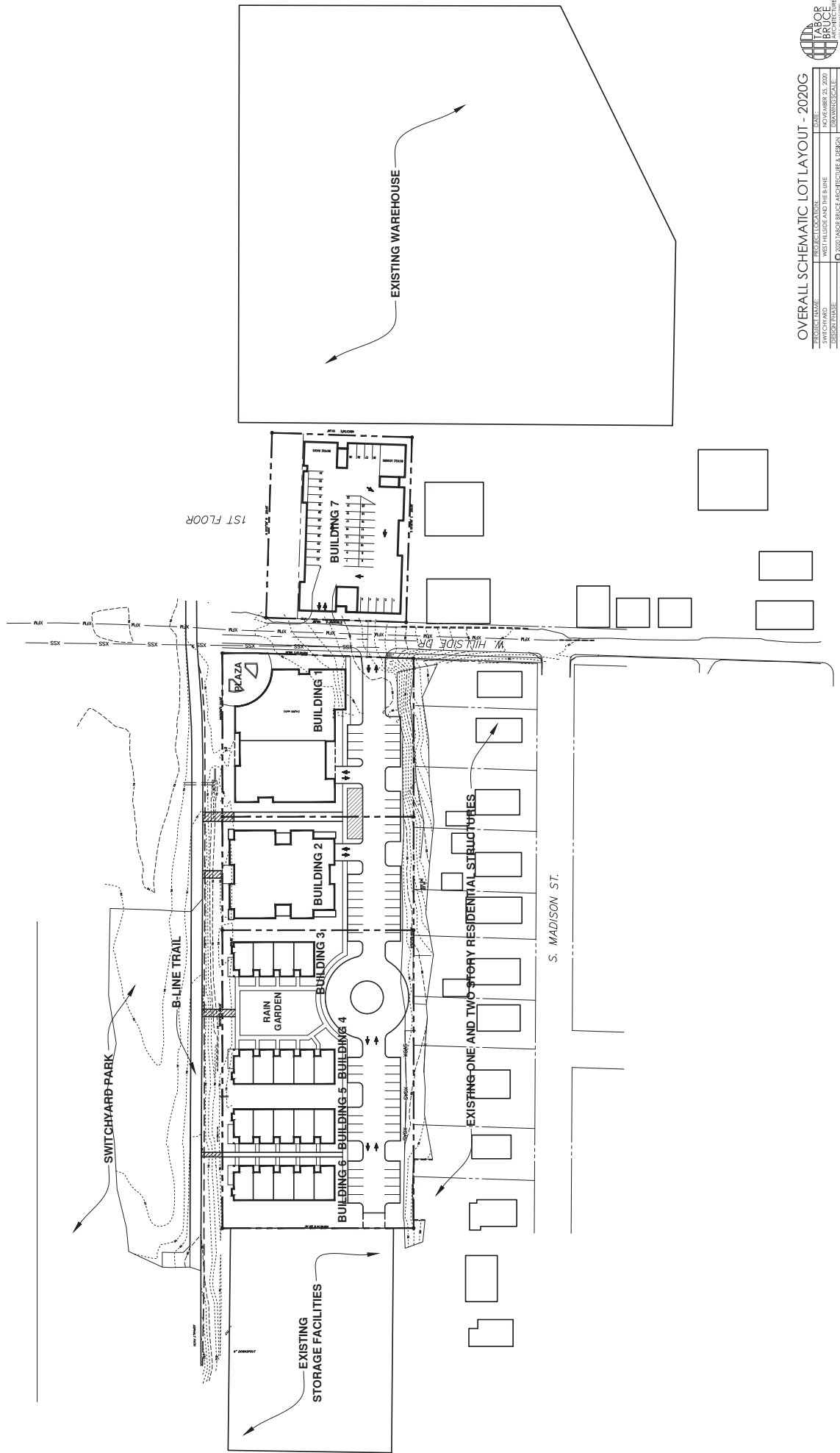





PROJECT NAME	PROJECT LOCATION	DATE
SWITCHYARD	WEST HILLSIDE AND THE BLINE	NOVEMBER 25, 2020
DRAWN BY	SCALE	DATE
ARCHITECTURE & DESIGN INC.	CONCEPT PLANNING	11-25-20

SCHEMATIC LOT LAYOUT - 2020G

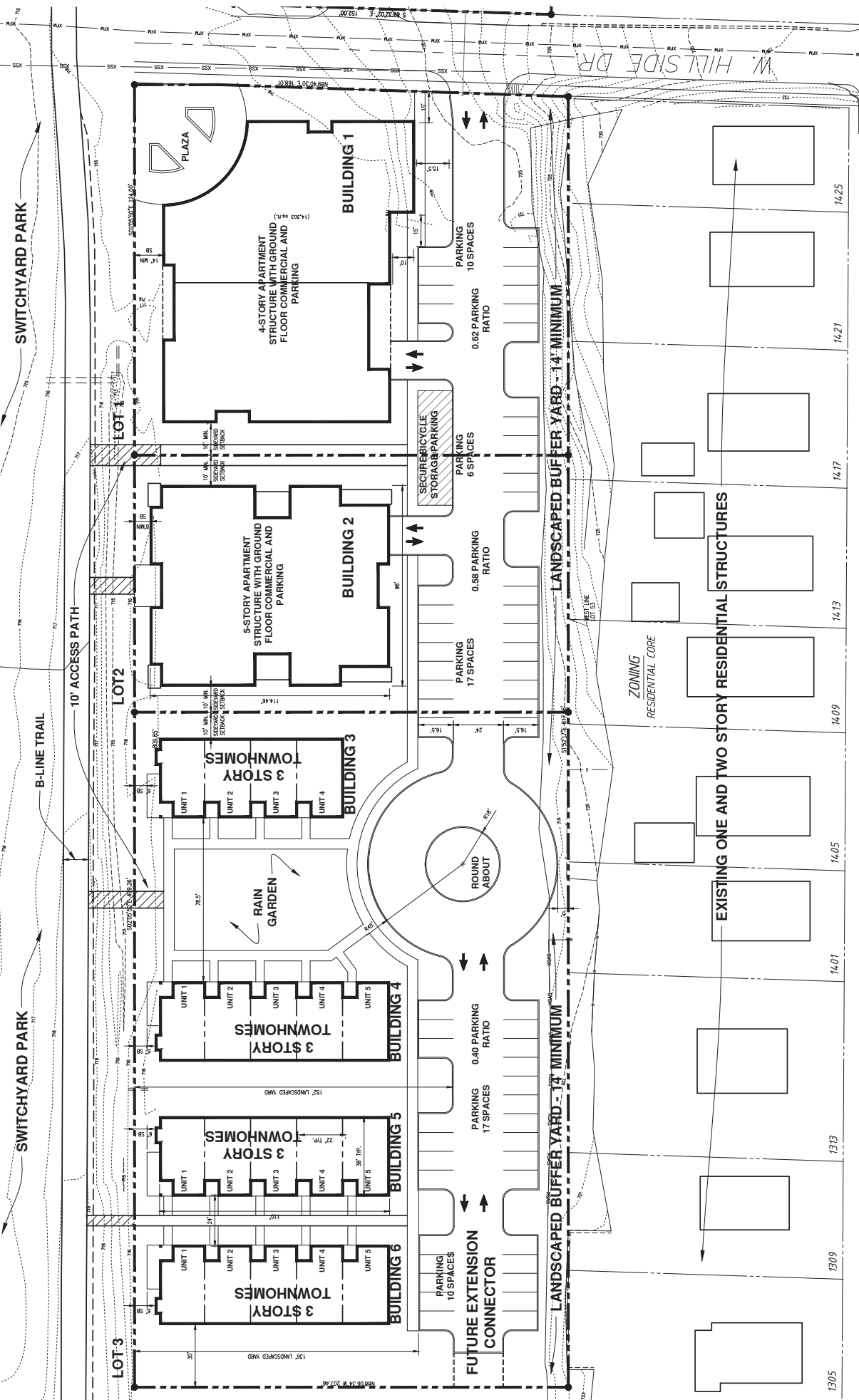

S. MADISON ST.

W. WILSON ST.



**SCHEMATIC LOT LAYOUT - SOUTH LOT**

PROJECT NAME: WEST HILLSIDE AND THE BLIND  
 PROJECT LOCATION: WEST HILLSIDE AND THE BLIND  
 DATE: NOVEMBER 4, 2020  
 DESIGN SCALE: ARCHITECTURE & DESIGN  
 CONCEPT PLANING: ARCHITECTURE & DESIGN  
 DRAWING SCALE: 1" = 20'-0"

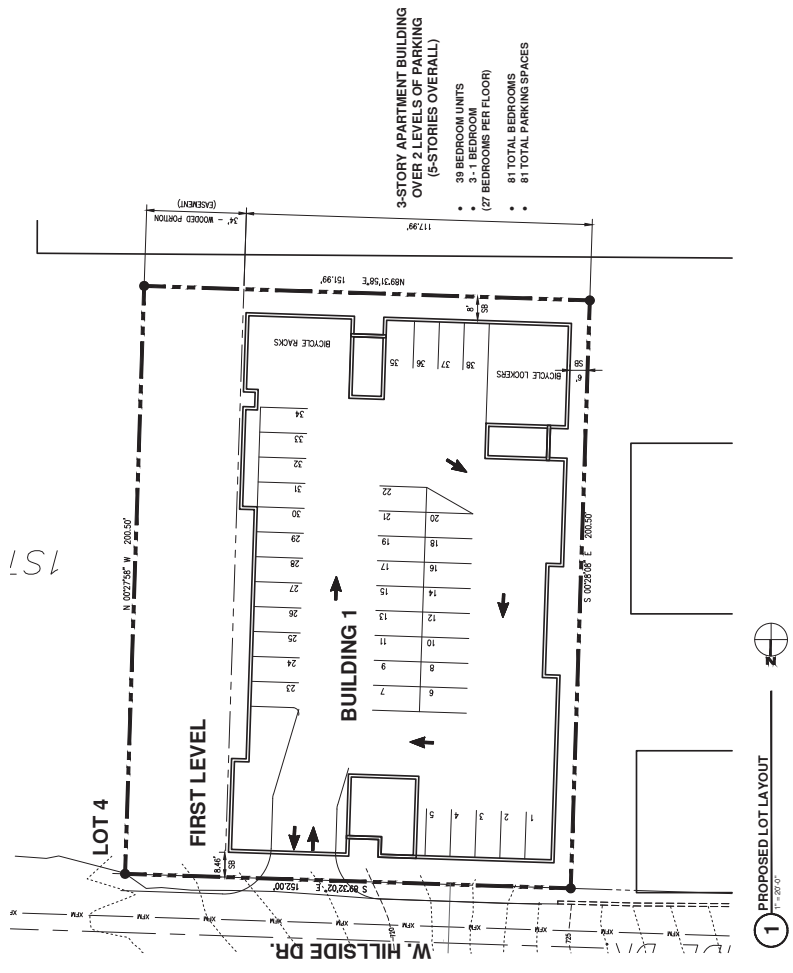

**3-STORY APARTMENT BUILDING  
OVER 2 LEVELS OF PARKING  
(5-STORIES OVERALL)**

- 39 BEDROOM UNITS
- 27 BATHS
- 27 BEDROOMS PER FLOOR
- 81 TOTAL BEDROOMS
- 81 TOTAL PARKING SPACES

**1** PROPOSED LOT LAYOUT  
1" = 20'-0"





































Legend  
Photo







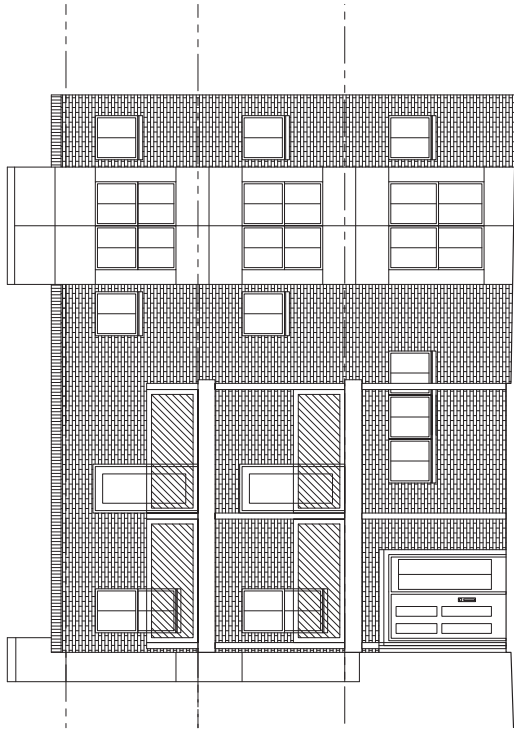

ELEVATION FACING PARK



TOWNHOME BUILDINGS

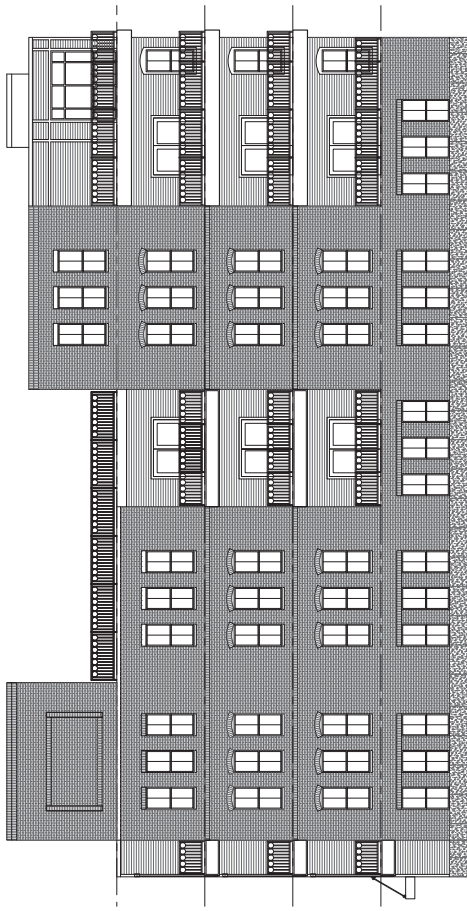

BUILDING 2

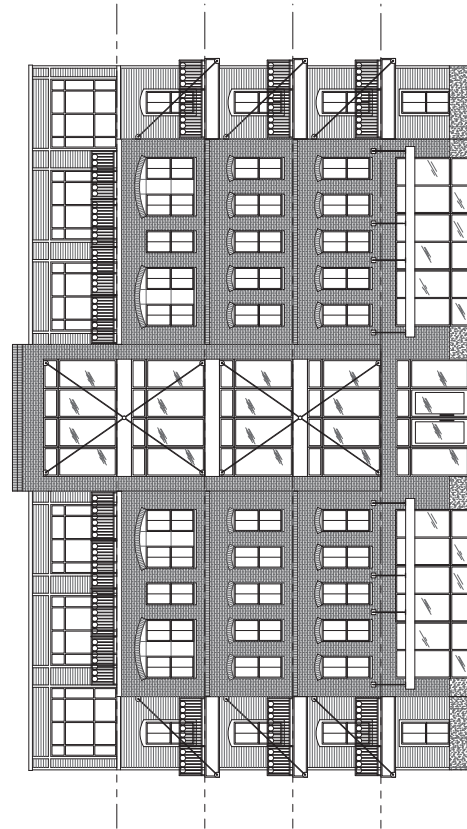

BUILDING 1

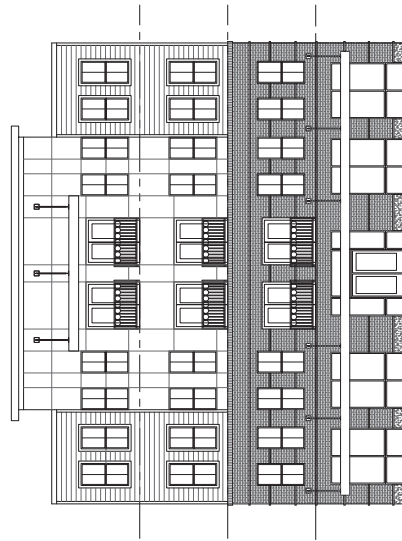

**PROPOSED BUILDING ELEVATIONS**

PROJECT NAME	DATE
SWITCHBOARD	NOVEMBER 12, 2009
DESIGN PHASE	EXAMINE AND RE-DESIGN
CONCEPT PLANING	1/8" = 1'-0"

PROJECT LOCATION: WEST HILLSIDE AND THE BLINE

DESIGNER: TAYLOR BRUCE ARCHITECTURE & DESIGN, INC.

1000 HARBOR BRUCE ARCHITECTURE & DESIGN, INC.



PROPOSED BUILDING ELEVATIONS	
PROJECT NAME:	WEST HARBOR AND THE BLINE
PROJECT LOCATION:	WEST HARBOR AND THE BLINE
DATE:	NOVEMBER 14, 2020
DESIGN PHASE:	CONCEPT PLANNING
DRAWING SCALE:	1/8" = 1'-0"
ARCHITECTURE & DESIGN:	TABOR BRUCE ARCHITECTURE & DESIGN, INC.
ARCHITECT:	TABOR BRUCE ARCHITECTURE & DESIGN, INC.

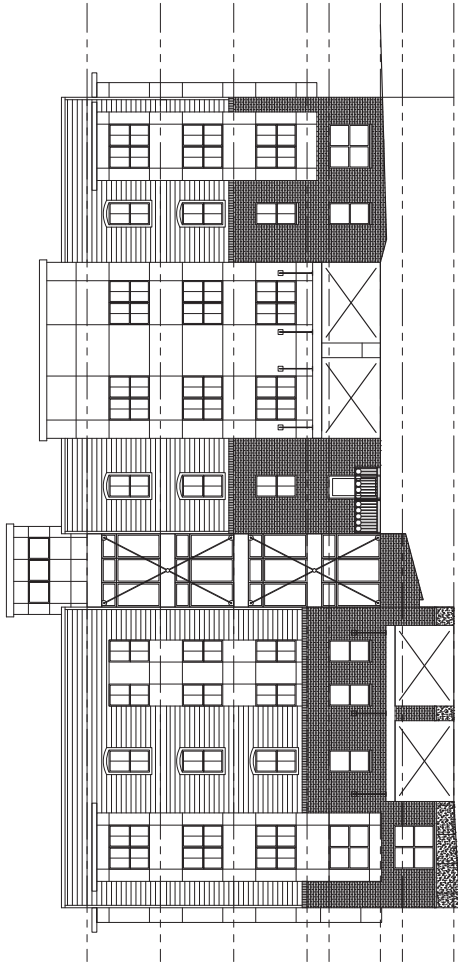

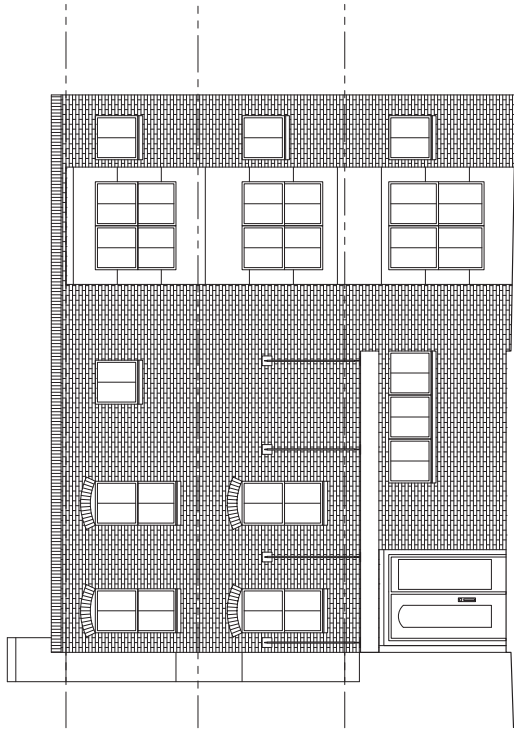

ELEVATION FACING PARK

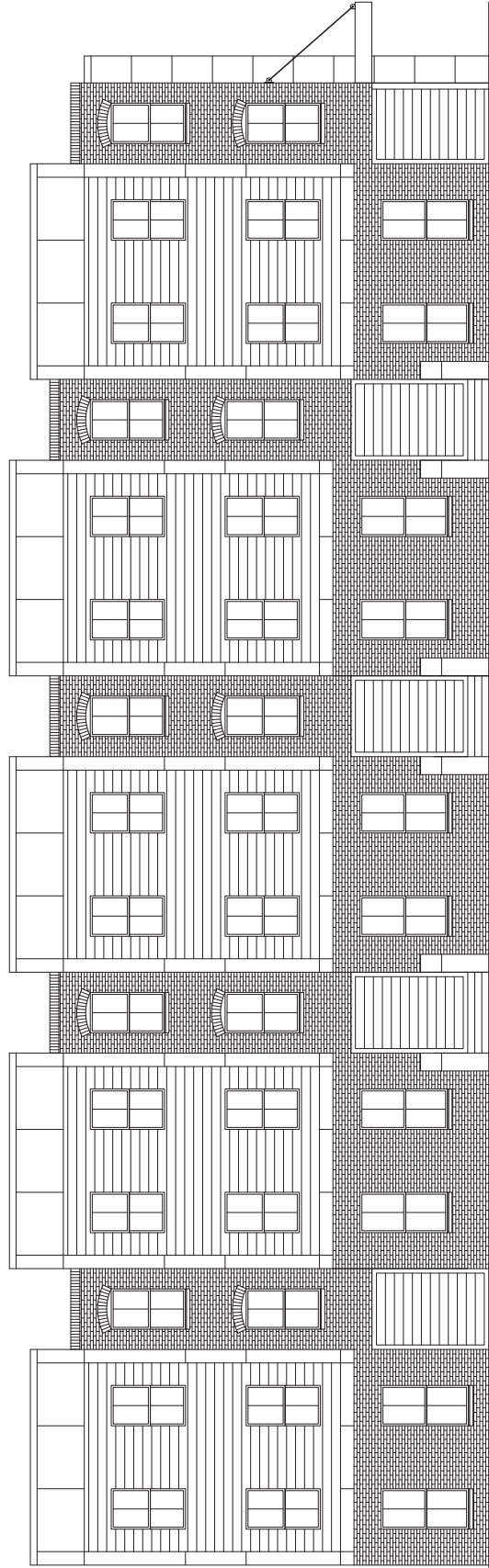

TOWNHOME BUILDINGS

**PROPOSED BUILDING ELEVATIONS**

PROJECT NAME:	PROJECT LOCATION:	DATE:
SWITCHYARD	WEST HILLSIDE AND THE PLAZA	NOVEMBER 23, 2021
DESIGN TITLE:	ARCHITECT:	DRAWING SCALE:
CONCEPT PLANNING	2020 FABOR BRUCE ARCHITECTURE & DESIGN	1/4" = 1'-0"

FABOR BRUCE ARCHITECTURE & DESIGN INC.  
 1000 WEST HILLSIDE AVENUE, SUITE 100, RALEIGH, NC 27601  
 TEL: 919.873.1100 FAX: 919.873.1101

**PROPOSED LAYOUT - FIRST LEVEL**

PROJECT NAME: MAJOR BRUCE ARCHITECTURE & DESIGN INC.  
 PROJECT LOCATION: WEST HILSDALE AND THE BLIND  
 DATE: NOVEMBER 14, 2020  
 DESIGNER: MAJOR BRUCE ARCHITECTURE & DESIGN  
 DRAWING SCALE: 1/8" = 1'-0"  
 CONCEPT PLANING

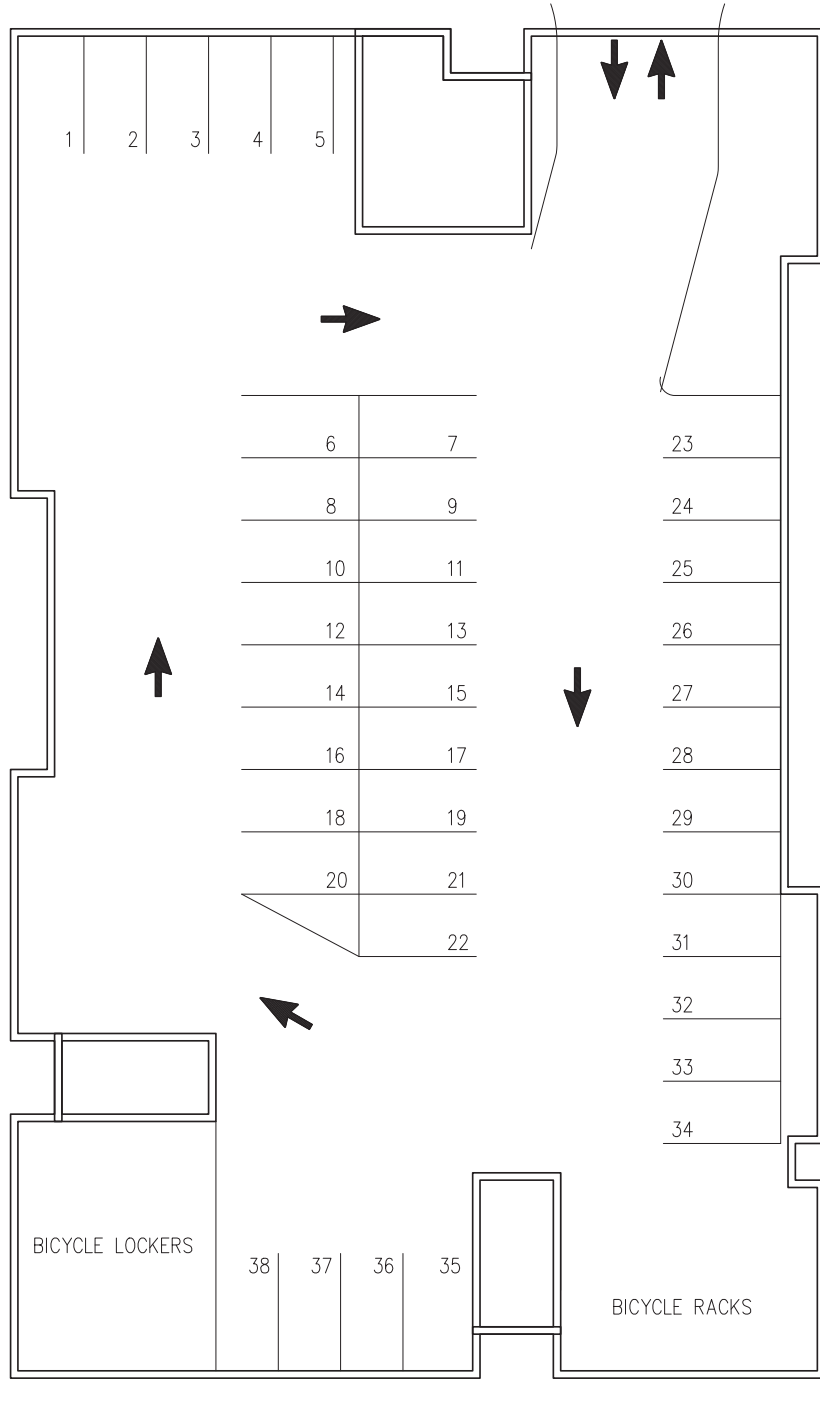





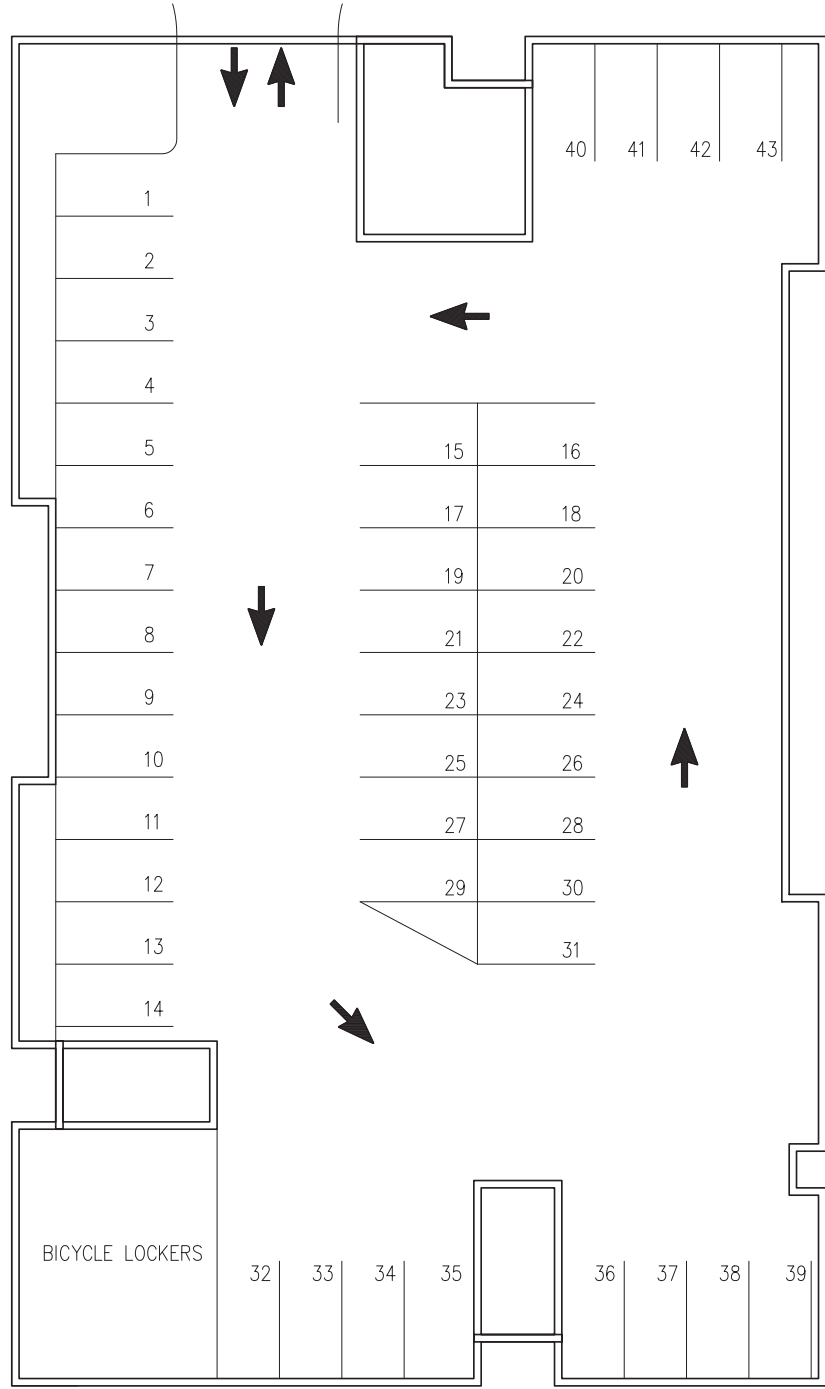

**PROPOSED LAYOUT - SECOND LEVEL**

PROJECT NAME: WEST HILLSIDE AND THE BLIND  
 PROJECT LOCATION: WEST HILLSIDE AND THE BLIND  
 DATE: NOVEMBER 14, 2020  
 DESIGN PHASE: CONCEPT PLANNING  
 DRAWING SCALE: 1/8" = 1'-0"



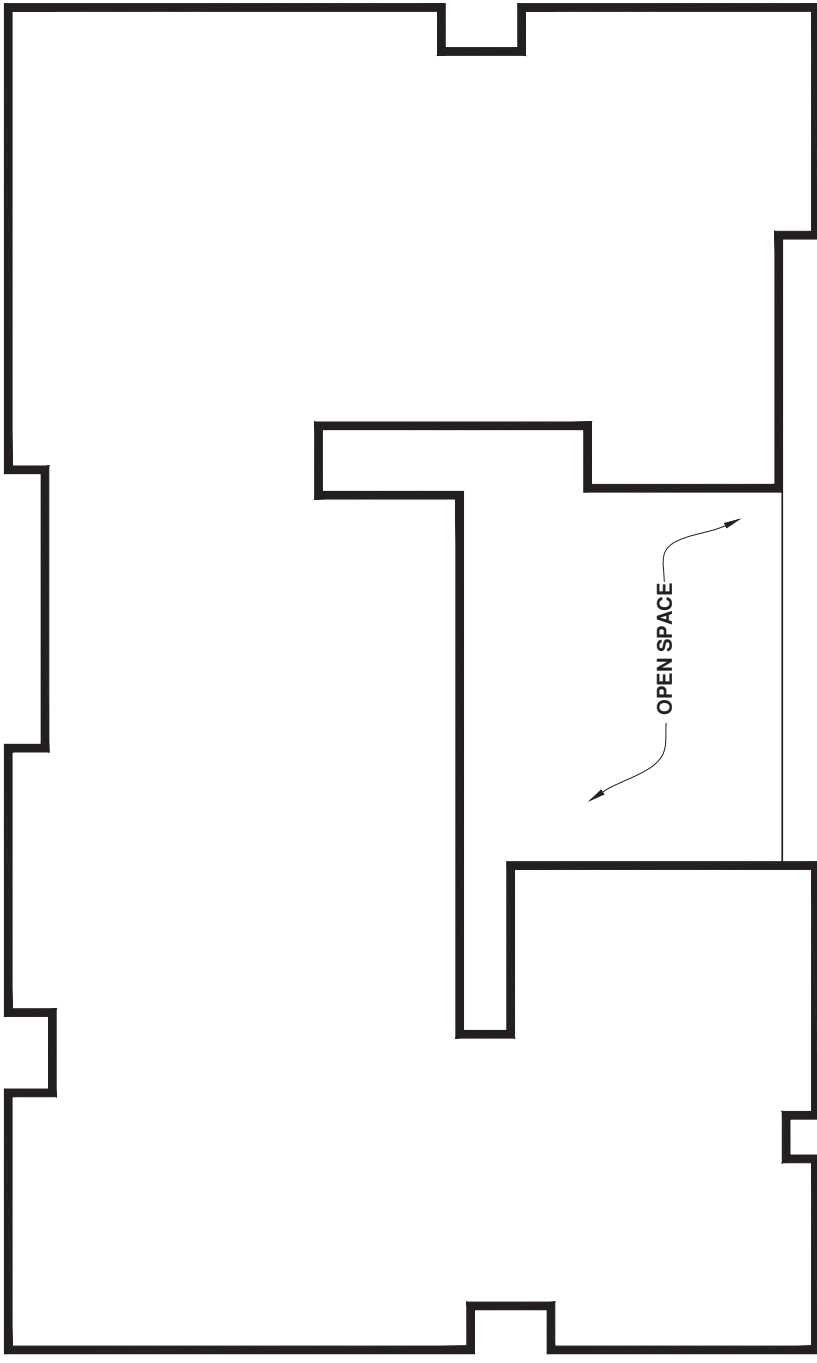

BUILDING 7

**PROPOSED LAYOUT - THIRD LEVEL - FIFTH LEVEL**

PROJECT NAME:	WEST HILLSIDE AND THE BLIND	DATE:	NOVEMBER 14, 2020
PROJECT LOCATION:	WEST HILLSIDE AND THE BLIND	DRAWING SCALE:	1/8" = 1'-0"
DESIGN FASE:	CONCEPT PLANNING		

  
 MAJOR BRUCE ARCHITECTURE & DESIGN, INC.  
 ARCHITECTURE & DESIGN, INC.  
 1000 WEST HILLSIDE AVENUE, SUITE 100  
 WEST HILLSIDE, ILLINOIS 60090

**BLOOMINGTON PLAN COMMISSION  
STAFF REPORT – Second Hearing  
LOCATION: 3100 W. Fullerton Pike**

**CASE #: ZO-23-20  
DATE: December 14, 2020**

**PETITIONER:** Bill C. Brown Revocable Trust  
300 S. State Road 446, Bloomington

**CONSULTANT:** Michael L. Carmin.  
116 W. 6<sup>th</sup> Street, Bloomington

**REQUEST:** The petitioner is requesting to rezone 87 acres from Planned Unit Development (PUD) to Mixed Use Corridor (MC).

**BACKGROUND:**

**Area:** 87 acres  
**Current Zoning:** Planned Unit Development  
**Comp Plan Designation:** Employment  
**Existing Land Use:** Undeveloped  
**Proposed Land Use:** None  
**Surrounding Uses:** North – Southern Indiana Medical Park  
South – Undeveloped (County Jurisdiction)  
East – Quarry (County Jurisdiction)  
West – Interstate 69 (County Jurisdiction)

**CHANGES SINCE FIRST HEARING:** This petition was heard at the November 9<sup>th</sup> Plan Commission meeting. At that time the Plan Commission discussed the proposal and expressed concern regarding preserving land for Employment uses. The petitioner mentioned the possibility of restricting possible uses, however no proposal for restricting uses was given to the Department. The petition remains as previously presented with no changes.

**REPORT:** This 87 acre property is located at the northeast corner of State Road 37 and W. Fullerton Pike. The site is currently undeveloped. This property was zoned Planned Unit Development (PUD) in 1988 (PCD-36-88) largely for industrial uses. The property received a final plan approval for an assisted care living facility in 1997 (PUD-6-97) and a PUD amendment in 1999 (PUD-15-99) to include a nine-hole, Par 3 golf course to the list of approved uses. This site was also evaluated in 2003 and 2004 in association with rezoning requests for the large vacant property to the north (Southern Indiana Medical Park II). No formal approvals for this parcel were sought at that time. A site plan approval (PUD-10-15) was approved in 2015 to allow for some of the topsoil from this site to be removed for the construction of I-69. The portions of the site that contain tree canopy coverage and riparian buffers were set aside in the required easements with the 2015 site plan approval.

The petitioner is requesting to rezone this property from a Planned Unit Development to Mixed-Use Corridor (MC). No development plan is being requested at this time and no conceptual site plan has been submitted. For reference, on the draft zoning map that has been proposed, this area is proposed to be rezoned to Mixed-Use Employment. While there are some uses within the Mixed-Use Corridor that are also allowed in the Mixed-Use Employment district, there are some specific uses that may or may not be appropriate for this area including big box retail, vehicle fuel station (e.g. truck stop), car washes, vehicle sales, and vehicle repair. Through the map update and text

amendment process, the Department is evaluating possible changes to the use list for the Mixed-Use Employment district, however it is unlikely that the uses listed above would be proposed additions.

---

**20.06.070(b)(3)(E)(i)(1) ZONING MAP AMENDMENT PLAN COMMISSION REVIEW AND RECOMMENDATION:**

The following criteria are those that the Plan Commission must consider when reviewing a zoning map amendment request.

[a] The recommendations of the Comprehensive Plan;

**PROPOSED FINDING:** The Comprehensive Plan designates this site as ‘Employment’. The Employment district includes professional and business offices, light assembly plants, flex-tenant facilities, and research and development centers. The Plan also states that the Employment district should contain a mix of office and light/high-tech manufacturing uses that provide quality employment opportunities for the Bloomington community. The proposed district, MC, would not align as well with the Employment category as the Employment or Mixed-Use Employment zoning districts would.

[b] Current conditions and character of structures and uses in each zoning district;

**PROPOSED FINDING:** The site is undeveloped and is in a prime location for employment uses with direct access from Interstate 69. This ease of access to a regional interstate makes this an ideal location for employment uses that would employ people from a wide area surrounding this site.

[c] The most desirable use for which the land in each zoning district is adapted;

**PROPOSED FINDING:** The most desirable use for this land is to follow the recommendations of the recently adopted Comprehensive Plan that call out for employment uses. The Comprehensive Plan recommendation for this site is in keeping with the Employment designation for this entire area along Interstate 69 and continues the employment uses to the north of this site. In addition, the amount of undeveloped property within the community that is zoned for Mixed Use Employment is much less than the amount of land zoned for Mixed Use Corridor, which places a great importance on preserving land for Employment uses.

[d] The conservation of sensitive environmental features;

**PROPOSED FINDING:** The environmental features on this site were set aside in the 2015 approval and placed in the required easements.

[e] The conservation of property values throughout the jurisdiction; and

**PROPOSED FINDING:** The rezoning of this PUD to either the Mixed Use Employment district or the Mixed Use Corridor are not anticipated to have any negative impacts on adjacent property values throughout the jurisdiction.



[f] Responsible development and growth

**PROPOSED FINDING:** The rezoning of this property to Mixed Use Corridor would result in the loss of a large area of property that is appropriately located to a regional interstate system that would best be served for Employment Uses. This location is not easily accessed from within the City and therefore not ideal for uses with high daily vehicular traffic. It is essential to protect property that is best served for Employment uses to maintain responsible development and growth for the community by providing areas for office parks and other employment uses to locate.

---

**CONCLUSION:** The Department believes that the rezoning of this site to Mixed Use Corridor would not match the Comprehensive Plan designation of the site as Employment. While some of the uses in MC are conducive to employment, many more uses are not and the EM or ME zoning districts are more appropriate for this prominent intersection, and in line with the Comprehensive Plan. In addition, the Department has already proposed to rezone this Planned Unit Development to Mixed Use Employment in the proposed draft zoning map.

---

**RECOMMENDATION:** The Department recommends forwarding this petition to the Common Council with a denial recommendation.



City of Bloomington  
Bloomington Environmental Commission

## MEMORANDUM

Date: November 9, 2020

To: Bloomington Plan Commission

From: Bloomington Environmental Commission

Subject: ZO-23-20: Bill C. Brown Revocable Trust Rezone  
3100 W. Fullerton Pike

The purpose of this memo is to convey the environmental concerns and recommendations for conditions of approval from the Environmental Commission (EC) with the hope that action will follow to enhance its environment-enriching attributes. The request is to rezone the property from PUD to Mixed-Use Corridor (MC).

The EC has no objection to the rezoning of this property with the following conditions of approval.

### COMMENTS

#### 1. Conservation Easement signs

All easements shall be identified with public signs located along the boundary of the easement. Public signs shall be placed at intervals of no more than two hundred feet, and each sign shall be a maximum of one and one-half square feet in area. A minimum of one public sign is required, regardless of easement size. The property owner shall be responsible for installing and maintaining required signage.

#### 2. Additional information regarding the karst geology

At the time of the previous petitioner's request, the EC recommended a through geologic investigation. The reason is that the soil is very thin and there are sinkholes and springs on the site and the surrounding area. Excavation of the soil and bedrock will likely expose more sensitive features. Because karst features that are not now obvious should also be protected if exposed, the EC believes the geologic investigation should be conducted. The staff report from 2015 states that staff thinks this investigation should be completed at the time of rezone, which is now.

Below you find the part of the staff report referred to. Additionally, you will find the 2015 EC memo requesting further investigations. The part that is struck out, does not relate to this petition.

**BLOOMINGTON PLAN COMMISSION CASE NO: PUD-10-15****STAFF REPORT DATE: April 13, 2015****LOCATION: 3100 W. Fullerton Pike****PETITIONER: Bill C. Brown**

300 S. SR 446, Bloomington

**ENVIRONMENTAL COMMISSION:** The Environmental Commission has reviewed this petition and offered the following recommendations:

1.) The Petitioner should get a geological evaluation to describe what karst features are hidden beneath the ground surface and describe how the surface and subsurface water regime will be impacted with soil excavation.

2.) The Petitioner should get an evaluation from a Soil Scientist that describes the health and vitality of the subsurface soil that will eventually be on the surface.

**Staff's Response (1 & 2):** Staff finds that the proposed testing would only be appropriately required if it were attached through a rezoning process and not at a final plan stage. The proposed grading meets the environmental standards and will be protected in a manner consistent with the UDO and the PUD.

3.) The Petitioner should reconsider the location of the road bed to avoid the high quality woods to the north.

**Staff's Response:** Staff finds that the proposed location is both appropriate and consistent with the past approvals for this property and the property to the north. Furthermore, no construction of the road is proposed and future construction will be reviewed by the Plan Commission.

**CONCLUSION:** As previously stated, this proposal does not include any buildings or use of the property and only proposes grading activities. The proposal must receive Plan Commission approval only because no grading can occur without a PUD final plan approval. The proposed grading will not excessively denude the site of usable soil and will not encroach into environmentally sensitive portions of the site as regulated by the Unified Development Ordinance. Therefore, staff is supportive of this request.

**RECOMMENDATION:** Staff recommends approval of PUD-10-15 with the following conditions:

1. The petitioner must retain 50 percent of the topsoil for use on-site to promote stabilization of the soil after grading.
2. No grading is permitted without an approved grading permit.
3. Required easements for slopes over 18 percent, riparian buffers, and karst features must be identified and recorded prior to the release of a grading permit



City of Bloomington  
Bloomington Environmental Commission

**MEMORANDUM**

**Date:** April 6, 2015

**To:** Bloomington Plan Commission

**From:** Bloomington Environmental Commission

**Through:** Linda Thompson, Senior Environmental Planner

**Subject:** PUD-10-2015, Bill Brown Trust, Fullerton Pike  
South SR 37 and West Fullerton Pike

*This memorandum contains the Environmental Commission's (EC) input and recommendations regarding a request for a PUD Final Plan for grading work. The request includes removal of several feet of topsoil and road bed preparation. The EC believes this project will have negative environmental effects that may not be apparent at first glance, thus does not support the proposal.*

**ISSUES OF SOUND ENVIRONMENTAL DESIGN:**

**1.) KARST PROTECTION:**

*There are two sinkholes on the western edge of the site where it is nearly the highest point on the property. The sinkholes will be protected during excavation, and afterwards the outer edge of the sinkholes will be higher than the surrounding surface. To help envision this after grading is complete, imagine a volcano that extends upward from the ground surface, or perhaps a sump drain that is elevated above the floor. What this means is that no water will be able to flow into the sinkholes, thus cutting off the existing water supply to the subsurface karst system. The UDO (20.05.042 (a) (6)) states "Stormwater discharge into a karst feature shall not be increased over its pre-development rate. In addition, such discharge into a karst feature shall not be substantially reduced from pre-development conditions." The EC fears that depleting the sinkholes of their current water infiltration will diminish the water reaching the spring just downslope and change the entire water regime leading to the wetlands near the bottom of the watershed.*

*Because of the probable negative impact to this entire ecosystem, the EC believes that the Petitioner should do more research regarding the effects of changing the hydrologic behavior in the entire watershed. Some information to be gleaned before approval include the following.*

*A geotechnical audit that identifies karst features that may be uncovered with excavation, thus revealing the limitations such features impose on site development, and predict changes in hydrologic behavior.*

*This will require a geologic investigation conducted by a Professional Geologist. The investigation results need to include, depict, illustrate, and/or portray at least the following to the satisfaction of the EC and the Senior Environmental Planner.*

- a. A karst inventory for the whole sub watershed. The site is an integral part of a regional karst system and does not stand alone; therefore, it cannot be evaluated without considering the whole surface and subsurface drainage system. This includes all karst features (sinkholes, springs, grikes, underground water conduits, fracture liniments, voids, caves, etc.) expressed on the surface and in the subsurface.*
- b. Due to the intensity of karst features in the vicinity, any soil borings used to portray the bedrock surface should be drilled on a grid spaced more densely than typically used to identify a bedrock surface.*
- c. After identifying any newly-found karst features, which will contribute to the control and form the drainage regime, the stormwater and groundwater flow patterns must be identified and mapped.*
- d. Map the bedrock topography (this means the top of the subsurface rock and not the surface soil topography) and locate bedrock voids.*
- e. The results of the research and methods used to reach the conclusions of the above suggestions should be included within the environmental review plan. Examples of research methods that could be employed are:*

*Natural Potential (NP)  
 Electrical Resistivity Tomography (ERT)  
 Seismic  
 Electromagnetic (EM)  
 Microgravity  
 Infrared Thermal Scanning  
 Dye Tracing  
 Exploratory Soil Boring  
 Exploratory Rock Coring  
 Ground-Penetrating Radar*

## 2.) DENUDED SOIL BIOLOGY:

*Because there are so many living organisms in soil, the EC recommends that a Soil Scientist be employed to describe what the remaining surface will contain and whether or not it will be able to support life. If terra Rosa is all that is left on the surface, amendments may need to be applied in order for plant life to regenerate. The soil ecosystem is teaming with biodiverse organisms that enable plants to take up nutrients necessary for survival. A chart from Colorado State University Extension <http://www.ext.colostate.edu/mg/gardennotes/212.html> exemplifies this.*





City of Bloomington  
Bloomington Environmental Commission

*Table 1.  
Organisms typically found in one cup of undisturbed native soil*

<i>Organism</i>	<i>Number</i>
<i>Bacteria</i>	<i>200 billion</i>
<i>Protozoa</i>	<i>20 million</i>
<i>Fungi</i>	<i>100,000 meters</i>
<i>Nematodes</i>	<i>100,000</i>
<i>Arthropods</i>	<i>50,000</i>

**3.) ROAD CONNECTION:**

*The EC is not in favor of the future road stubbing into the adjoining woods at the location shown on the plans. In the past, there was much discussion regarding saving the mature woodland to the north of this property. The EC would still recommend protecting that woods.*

**EC RECOMMENDATIONS:**

- 1.) The Petitioner should get a geological evaluation to describe what karst features are hidden beneath the ground surface and describe how the surface and subsurface water regime will be impacted with soil excavation.*
- 2.) The Petitioner should get an evaluation from a Soil Scientist that describes the health and vitality of the subsurface soil that will eventually be on the surface.*
- 3.) The Petitioner should reconsider the location of the road bed to avoid the high quality woods to the north.*

**RECOMMENDED CONDITIONS OF APPROVAL for November 9, 2020**

1. All signs that were required to be installed at the edges of the Conservancy Easements shall be installed now. This requirement is found in both the previous and current UDOs.
2. A geologic evaluation of the hydrology, soil health, and karst features will be conducted by a Licensed Professional Geologist (LPG) per the request in the April 6, 2015 EC memo to the Plan Commission before the issuance of any permits.

PCL-36-8688

Permitted Uses

MP Zone

MP Manufacturing--Park

## 20.07.05.00 BUSINESS

A. Commercial, Retail

NA

B. Commercial Trade

1. Business Service
2. Business & Prof. \*23
3. Schools (Trade & Bus.)
4. Building Trades Shop
5. Warehouses

C. Commercial, Wholesale

1. Building Material \*24
2. Farm Products \*24
3. Farm Supplies \*24
4. Food Products
5. Household Goods

## 20.07.06.00 INDUSTRIAL

A. Manufacturing, Processing

1. Apparel
2. Bakery, Dairy Products, Confectionary
3. Beverage, Bottling
4. Chemicals & Chemical Products
5. Clock, Scientific Instruments
6. Drugs & Pharmaceuticals
7. Electronic Equipment
8. Furniture
9. Machinery, tool & die \*25
10. Meat, Poultry, Seafood \*18
11. Medical Equipment
12. Metal Fabrication \*25
13. Musical Instruments
14. Paper Products
15. Printing/Newspapers
16. Research Laboratories
17. Misc. Small Products
18. Sporting Goods, Toys, Novelties

B. Industrial Non-processing

1. Warehouse, Storage

\*18 Processing or freezing of dressed meat and poultry permitted in all M zones. Slaughter or dressing must receive special permission of the Plan Commission and is permitted only in the MG zone.

\*23 Corporate only; consumer-oriented offices prohibited.

\*24 All activities and storage must be conducted within a fully enclosed building.

\*25 Proposed facility shall be reviewed by Plan Commission and may be permitted only if its impacts are found to be consistent with those of other uses permitted in the MP district.

PETITION OF BILL C. BROWN

## Fullerton Pike and State Road 37 By-Pass

The Petitioner submits the following additional statement in support of his Petition.

ADDITIONAL USES.

Professional corporate and commercial offices  
 Health care (extended care)  
 Motel with sit down restaurant (limited to 100 lodging units and 125 seating capacity for restaurant. Restaurant will have no drive-up or carry-out)  
 Mail order sales offices and storage with limited retail (retail will be a secondary or ancillary use only and will be limited to 3,000 square feet of sales and display)

COVENANTS. (to be part of the approval and made a covenant on the plat)

1. No tract shall be smaller than two (2) acres.
2. Buildings shall cover no more than thirty-five percent (35%) of the site.
3. All open space will be landscaped.
4. Existing vegetation/topography will be maintained to the maximum extent reasonably possible.
5. Loading docks and outside storage shall be screened by landscaping or decorative fence (if fence, the appearance and design shall be subject to the Architectural Committee approval)
6. All buildings and their maintenance will be subject to architectural approval by a committee selected by the developer. The following minimum standards shall be required:
  - a. No smooth surface concrete block will be used more than eighteen inches (18") above grade.
  - b. No pole barn construction will be permitted. No exterior walls giving the appearance of pole barn construction will be permitted.
  - c. One Hundred percent (100%) of exterior walls visible from State Road 37 By-Pass and Fullerton Pike shall be of masonry or glass construction. Use of metal for exterior walls will be permitted only if the metal has architectural style and is approved by the developer's architectural committee.
7. No structure or building shall be erected within fifty feet (50') of the right-of-way of State Road 37 By-Pass or Fullerton Pike.

OTHER AGREEMENT: Developer agrees to phase in the improvement of the Fullerton Pike entrance as the traffic generation of the development requires to meet accepted standards.

## CONDITIONS OF APPROVAL FOR BROWN INDUSTRIAL PARK - FULLERTON PIKE

1. Eliminate hotel/restaurant
2. Limit mail order/retail to
  - one only
  - maximum retail 3,000 sq. ft.
  - minimum mail order 12,000 sq. ft.
  - retail limited to products distributed by mail order component of business
3. Road access north and east - location to be determined at development plan
4. Fullerton access to be 390' east of east edge of northbound 37 pavement
5. Upgrade Fullerton from east end of entrance improvements to 3 lanes and improved pavement specifications
6. The design standards in the packet will govern development plan approval by Plan Commission. MP landscape requirements apply.

Motion for approval carried 6-4 (no's were: Behnke, Bonnell, Cooksey, Kiesling)

## Interdepartmental Memo

To: Members of the Common Council

From: <sup>TM</sup> Tom Micuda, Planning Department

Subject: Case # PUD-15-99

Date: May 25, 1999

Attached are the staff reports, petitioner's statements, location maps, and site plan exhibits which pertain to Plan Commission Case # PUD-15-99. The Plan Commission voted 9-0 to send the petition to the Council with a favorable recommendation.

---

### BACKGROUND

The petitioners are requesting a preliminary plan amendment to the permitted land use list for this 90 acre Planned Unit Development (PUD). This amendment would allow a nine-hole, Par 3 golf course to be constructed on the central 30 acres of this tract.

The property in question is located at the northeast corner of Fullerton Pike and State Road 37. This parcel was originally granted PUD approval in 1988. The focus of the 1998 PUD was to create pre-zoned land for both light and heavy manufacturing land uses. In addition to these uses, the petitioner was granted the right to develop health care facilities at this location.

For nine years, no final plan approvals were ever granted by the Plan Commission and the property remained vacant. However, on April 28, 1997, a final plan was approved which would have allowed the construction of a large assisted care facility. More specifically, the final plan authorized construction of a 96 unit assisted care facility on five acres, 32 condominium units on an additional 10 acre tract, future business park/office uses along SR 37 and Fullerton Pike, and future elderly housing on approximately 37 acres of sensitive wooded area to the east.

The owner of the PUD has since informed staff that the 1997 final plan approval will not be acted upon by the petitioner. This is due to a lack of sewer service. The nearest sewer line with adequate capacity is located at Tapp Road and cannot be realistically extended until adjacent property is developed. With this limitation in mind, the petitioner is seeking a PUD amendment to allow a nine hole, Par 3 golf



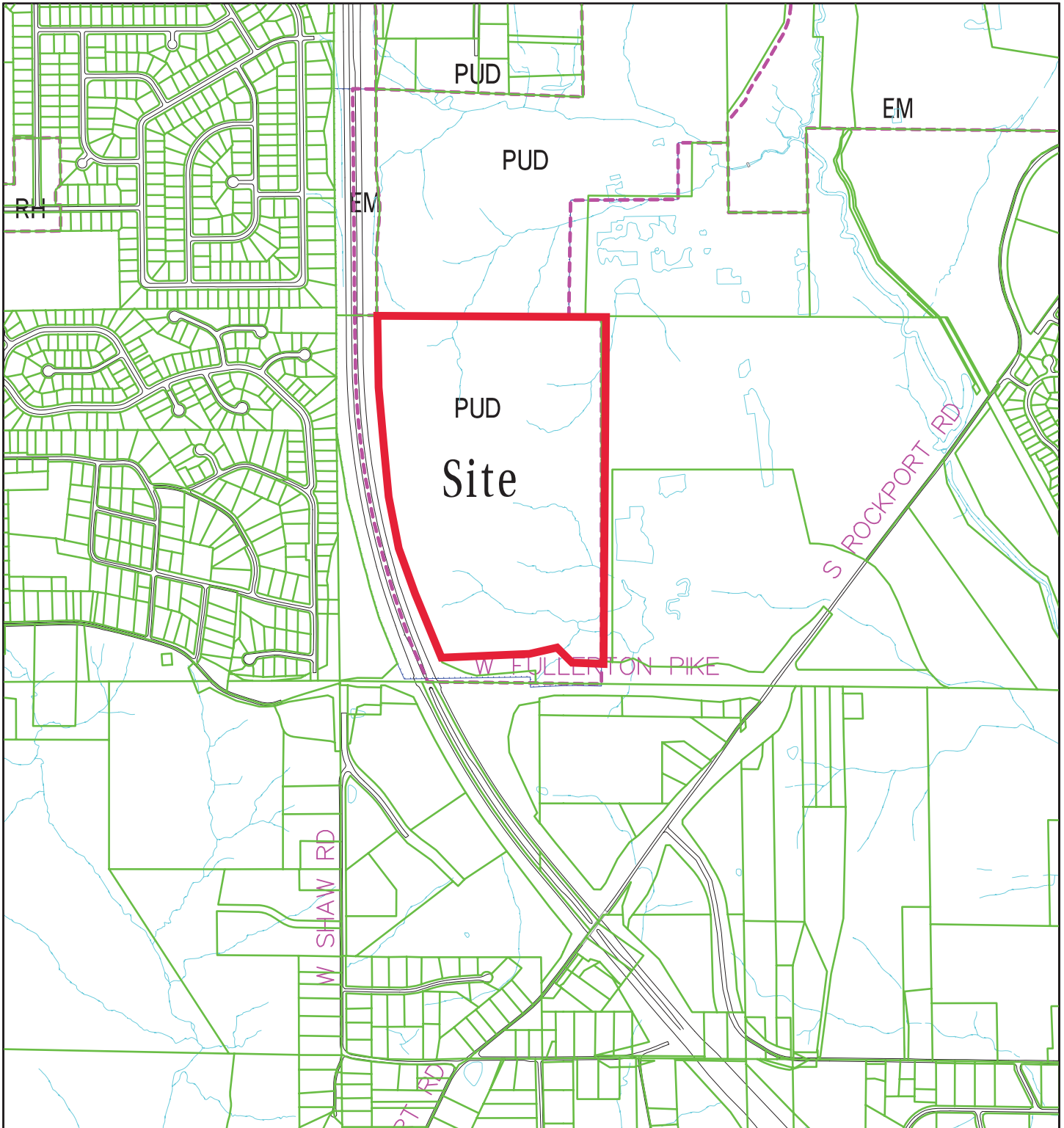

Bill Brown Fullerton Pike

By: greulice  
9 Oct 20

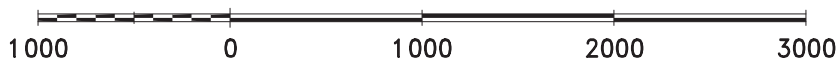

For reference only; map information NOT warranted.

City of Bloomington  
Planning & Transportation

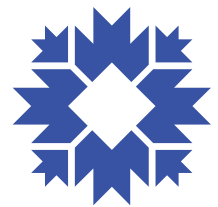

Scale: 1" = 1000'





By: greulice  
9 Oct 20

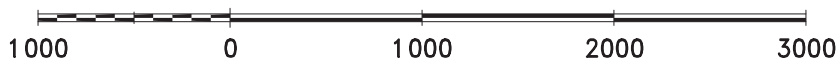

For reference only; map information NOT warranted.



City of Bloomington  
Planning & Transportation

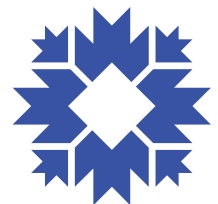

Scale: 1" = 1000'



## PETITIONER'S REZONING STATEMENT

Bill C. Brown Revocable Trust, Petitioner, requests rezoning of the PUD land located at Fullerton Pike and I-69 (northeast corner) consisting of 87.12 acres to mixed use-corridor (MC).

Unified Development Ordinance states the purpose for the MC zone as “intended to accommodate medium scaled developments with a mix of store front retail, professional office, and/or residential dwelling units along arterial and collector corners at a scale larger than the neighborhood-scale uses accommodated by the MN zoning district.”

**Current Planned Unit Development zone.** The existing PUD contains a variety of permitted uses, including:

- ◆ Commercial, retail
- ◆ Commercial, trade
- ◆ Commercial, wholesale
- ◆ Industrial – manufacturing and processing uses
- ◆ Industrial – non-processing use (warehouse)
- ◆ Professional, corporate and commercial offices
- ◆ Healthcare (extended care)
- ◆ Mail order sales offices and storage with limited retail

**PUD Development.** The Fullerton Pike PUD remains undeveloped. Approximately three acres of the PUD land along the south property line adjacent to Fullerton Pike was acquired by State of Indiana in connection with the I-69 development project. West Fullerton Pike adjacent to the PUD was widened and a roundabout constructed.

Proposed/Anticipated future development of the property includes:

- ◆ Hotel/motel
- ◆ Trade offices
- ◆ Governmental uses, including a training center
- ◆ Other employment uses
- ◆ Multi-family apartments

**Adjacent and surrounding uses.** The property is bordered on the east by a limestone quarry operation, on the north by vacant, undeveloped land, on the west by I-69 and west of I-69 are single family home developments, southwest is the Monroe Hospital development and the remaining land bordering on the south side of Fullerton Pike is one single family lot and undeveloped ground.

**Environmental Issues.** In August, 2015, Petitioner granted to the City of Bloomington conservancy and karst easements encumbering the PUD to identify, protect and preserve natural areas, slope areas, drainage ways and karst features.

**Petitioner's Intent.** The MC zone closely matches the PUD permitted uses. The property is bordered by I-69, an established corridor through the Monroe County community. Fullerton Pike is under development and is projected with land improvements and further development east to become a corridor from I-69 to South Walnut Street/Old State Road 37. The permitted uses in the MC zone are closely aligned with the breadth and scope of permitted uses in the existing PUD. Development standards for the MC zone are suitable for future development at this location. A specific development of the property is not planned at this time. Petitioner has been approached for possible development of a hotel in the southwest corner of the property, adjacent to I-69. Petitioner has also been approached to develop a large part of the property as a training center for fire and emergency services. It is expected that the City of Bloomington will seek to rezone the PUD at a future date. In order to promote development of the property, Petitioner seeks to clarify the zoning classification consistent with the recently adopted new Unified Development Ordinance with permitted uses appropriate to the zone without undue delay.

Petitioners request waiver of second hearing before the Plan Commission.

  
Michael L. Carmin  
Attorney for Petitioners

423648

2015011604 EASE \$36.00  
 08/18/2015 12:26:50P 12 PGS  
 Eric Schmitz  
 Monroe County Recorder IN  
 Recorded as Presented



## CONSERVANCY AND KARST EASEMENTS

THIS INDENTURE WITNESSETH, that Bill C. Brown Revocable Trust, hereinafter called GRANTOR, of Monroe County, State of Indiana grants to The City of Bloomington, the Grantee, for and in consideration of One Dollar (\$1.00) and other valuable consideration, the receipt of which is hereby acknowledged, Conservancy Easements and Karst Easements as defined below and as described on the attached exhibit "A"

**Conservancy Easement** – This easement is to protect natural areas and includes wooded areas, sloped areas, drainage ways and karst features. The following restrictions apply within the easement area;

- Any land disturbing activity including the placement of a fence, or alteration of any vegetative cover, including mowing, is prohibited in the easement area.
- Removal of dead or diseased trees that pose a safety risk or impede drainage as well as allowing the removal of exotic species is allowed only after first obtaining written approval from the City of Bloomington Planning & Transportation Department.
- In cases where removal of exotic invasive species is proposed, the restoration of disturbed areas with native plant material is allowed with written approval from the City of Bloomington Planning & Transportation Department prior to any proposed removal and restoration.
- Karst areas within this Conservancy Easement are also subject to any additional restrictions provided by the Karst Conservancy Easement.

**Karst Easement** – This easement is to protect the Karst features. The following restrictions apply within the easement area;

- No land disturbing activity, including the placement of a fence or the placement of any fill material is allowed within the easement area.
- No structures shall be located within 10 of the easement.
- Storm water discharge into the easement area shall not be substantially changed. The easement are shall not be used for storm water detention.
- Spring or cave entrances shall not be modified except for the placement of a gate to prevent human access.
- Mowing is allowed in the easement area. Removal of dead or diseased trees that pose a safety risk or impede draining as well as removal of exotic invasive species is allowed only after first obtaining written approval from the City of Bloomington Planning & Transportation Department.
- Right is granted to the City of Bloomington to enter the property to inspect the easement and alter or repair the karst feature.
- Any use of pesticides, herbicides, or fertilizers is prohibited within the easement area.



- Where removal of exotic invasive species is proposed, the restoration of the disturbed area with native plant material is allowed. Written approval of the City of Bloomington Planning & Transportation Department is required prior to any proposed removal and restoration.

IN WITNESS WHEREOF, the said Grantor has executed this instrument this \_\_\_\_\_ day of August, 2015.

Bill C. Brown Revocable Trust

By: 

Bill C. Brown, Trustee

STATE OF INDIANA        )  
  ) SS:  
COUNTY OF MONROE    )

SUBSCRIBED AND SWORN TO before me this 17<sup>th</sup> day of August, 2015.

My Commission Expires:

August 10, 2016

Larry J. Beckman / Larry J. Beckman  
Notary Public

Resident of Monroe County

I affirm, under penalties of perjury that I have taken reasonable care to redact each social security number from this document unless required by law.

  
Stephen L. Smith



This instrument prepared by Smith Brehob & Associates, Inc.  
453 South Clarizz Boulevard, Bloomington, IN 47401

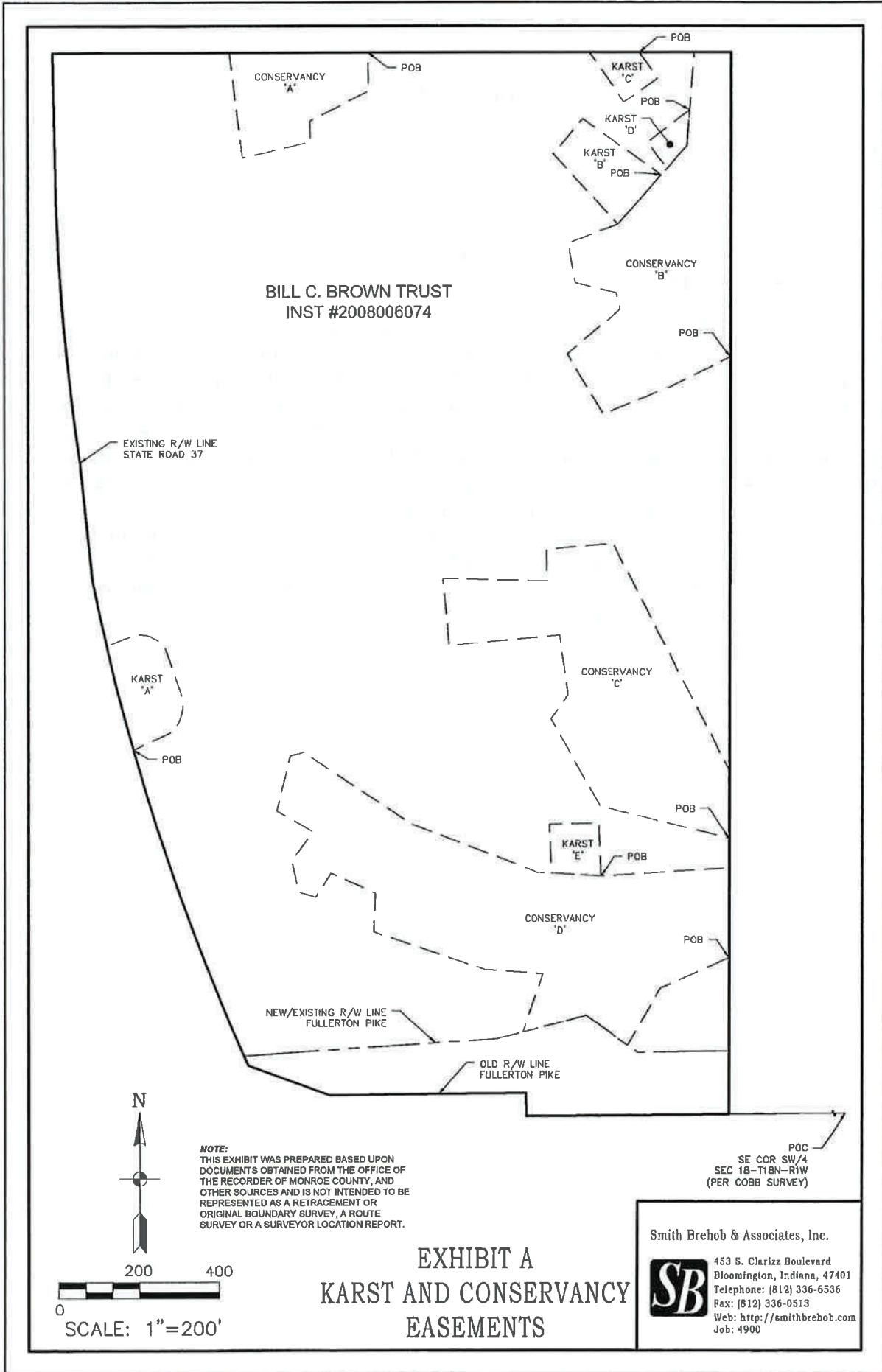

**Exhibit "A"**  
**"Conservancy Easement A"**

Project Number: 4900

LEGAL DESCRIPTION:

A part of the Southwest Quarter of Section 18, Township 9 North, Range 1 West, in Monroe County, Indiana, more particularly described as follows:

COMMENCING at the southeast corner of said quarter section; thence South 89 degrees 30 minutes 53 seconds West 885.32 feet on the south line of said quarter section to the southeast corner of Bill C. Brown Trust Fullerton Pike (Instrument #2008006074, in the Office of the Recorder, Monroe County, Indiana), thence leaving said south line and following east line of said property North 00 degrees 01 minutes 11 seconds East 2628.76 feet, thence leaving said east line and following north line of said property South 89 degrees 56 minutes 28 seconds West 901.21 feet to the POINT OF BEGINNING; thence continuing along said north line South 89 degrees 56 minutes 28 seconds West 341.42 feet; thence South 06 degrees 53 minutes 17 seconds East 261.41 feet; thence North 76 degrees 41 minutes 22 seconds East 171.94 feet; thence North 01 degrees 40 minutes 08 seconds West 50.99 feet; thence North 62 degrees 58 minutes 56 seconds East 164.48 feet; thence North 01 degrees 23 minutes 27 seconds West 94.63 to the POINT OF BEGINNING, containing 1.45 acres more or less.

**Exhibit "A"**  
**"Conservancy Easement B"**

Project Number: 4900

LEGAL DESCRIPTION:

A part of the Southwest Quarter of Section 18, Township 9 North, Range 1 West, in Monroe County, Indiana, more particularly described as follows:

COMMENCING at the southeast corner of said quarter section; thence South 89 degrees 30 minutes 53 seconds West 885.32 feet on the south line of said quarter section to the southeast corner of Bill C. Brown Trust Fullerton Pike (Instrument #2008006074, in the Office of the Recorder, Monroe County, Indiana), thence leaving said south line and following east line of said property North 00 degrees 01 minutes 11 seconds East 1875.23 feet to the POINT OF BEGINNING; thence continuing on said east line of said property North 00 degrees 01 minutes 11 seconds East 753.53; thence leaving said east line and following the north line of said property South 89 degrees 56 minutes 28 seconds West 90.98 feet; thence leaving the north line of said property South 04 degrees 21 minutes 56 seconds West 231.89 feet; thence South 41 degrees 22 minutes 46 seconds West 259.24 feet; thence South 69 degrees 32 minutes 56 seconds West 131.82 feet; thence South 10 degrees 29 minutes 21 seconds East 100.61 feet; thence South 76 degrees 26 minutes 07 seconds East 105.45 feet; thence South 14 degrees 04 minutes 29 seconds East 40.30 feet; thence South 49 degrees 51 minutes 40 seconds West 173.60 feet; thence South 31 degrees 06 minutes 21 seconds East 173.72 feet; thence North 67 degrees 57 minutes 31 seconds East 184.23 feet; thence North 63 degrees 22 minutes 02 seconds East 162.02 feet to the POINT OF BEGINNING, containing 4.71 acres more or less.

**Exhibit "A"**  
**"Conservancy Easement C"**

Project Number: 4900

**LEGAL DESCRIPTION:**

A part of the Southwest Quarter of Section 18, Township 9 North, Range 1 West, in Monroe County, Indiana, more particularly described as follows:

COMMENCING at the southeast corner of said quarter section; thence South 89 degrees 30 minutes 53 seconds West 885.32 feet on the south line of said quarter section to the southeast corner of Bill C. Brown Trust Fullerton Pike (Instrument #2008006074, in the Office of the Recorder, Monroe County, Indiana), thence leaving said south line and following east line of said property North 00 degrees 01 minutes 11 seconds East 683.70 feet to the POINT OF BEGINNING; thence leaving east line of said property North 76 degrees 08 minutes 59 seconds West 331.31 feet; thence North 29 degrees 35 minutes 48 seconds West 249.48 feet; thence North 35 degrees 30 minutes 41 seconds East 73.49 feet; thence North 08 degrees 02 minutes 01 seconds West 148.13 feet; thence South 84 degrees 43 minutes 31 seconds West 277.39 feet; thence North 05 degrees 21 minutes 35 seconds West 166.77 feet; thence South 88 degrees 38 minutes 10 seconds East 261.19 feet; thence North 01 degrees 24 minutes 29 seconds West 77.69 feet; thence North 84 degrees 51 minutes 42 seconds East 166.16 feet; thence South 27 degrees 17 minutes 23 seconds East 632.66 feet to said east line; thence South 00 degrees 01 minutes 11 seconds West along said east line 167.37 feet to the POINT OF BEGINNING, containing 5.52 acres more or less.



**Exhibit "A"**  
**"Conservancy Easement D"**

Project Number: 4900

LEGAL DESCRIPTION:

A part of the Southwest Quarter of Section 18, Township 9 North, Range 1 West, in Monroe County, Indiana, more particularly described as follows:

COMMENCING at the southeast corner of said quarter section; thence South 89 degrees 30 minutes 53 seconds West 885.32 feet on the south line of said quarter section to the southeast corner of Bill C. Brown Trust Fullerton Pike (Instrument #2008006074, in the Office of the Recorder, Monroe County, Indiana), thence leaving said south line and following the east line of said property North 00 degrees 01 minutes 11 seconds East 388.00 feet to the POINT OF BEGINNING; thence continuing on the east line of said property North 00 degrees 01 minutes 11 seconds East 222.40 feet; thence leaving the east line of said property South 86 degrees 18 minutes 32 seconds East 320.63 feet; thence North 86 degrees 24 minutes 33 seconds West 159.11 feet; thence North 69 degrees 14 minutes 20 seconds West 333.42 feet; thence North 56 degrees 32 minutes 29 seconds West 325.46 feet; thence South 73 degrees 43 minutes 37 seconds West 33.43 feet; thence South 13 degrees 51 minutes 44 seconds West 139.77 feet; thence South 59 degrees 58 minutes 16 seconds East 103.04 feet; thence South 36 degrees 17 minutes 33 seconds West 87.83 feet; thence South 12 degrees 13 minutes 16 seconds East 80.84 feet; thence South 73 degrees 34 minutes 39 seconds East 44.21 feet; thence North 32 degrees 16 minutes 02 seconds East 70.27 feet; thence South 65 degrees 49 minutes 55 seconds East 120.47 feet; thence South 02 degrees 24 minutes 30 seconds West 96.59 feet; thence South 71 degrees 25 minutes 46 seconds East 293.77 feet; thence South 86 degrees 04 minutes 49 seconds East 145.63 feet; thence South 19 degrees 22 minutes 08 seconds West 152.98 feet to existing right-of-way line of Fullerton Pike, the next (2) calls are along said right-of-way; thence (1) North 75 degrees 42 minutes 16 seconds East 163.63 feet; thence (2) South 54 degrees 36 minutes 23 seconds East 125.98 feet; thence North 30 degrees 20 minutes 41 seconds East 163.31 feet; thence North 66 degrees 09 minutes 05 seconds East 163.63 feet to the POINT OF BEGINNING, containing 7.68 acres more or less.

**Exhibit "A"**  
**"Karst Easement A"**

Project Number: 4900

LEGAL DESCRIPTION:

A part of the Southwest Quarter of Section 18, Township 9 North, Range 1 West, in Monroe County, Indiana, more particularly described as follows:

COMMENCING at the southeast corner of said quarter section; thence South 89 degrees 30 minutes 53 seconds West 885.32 feet on the south line of said quarter section to the southeast corner of Bill C. Brown Trust Fullerton Pike (Instrument #2008006074, in the Office of the Recorder, Monroe County, Indiana), thence continuing on said south line South 89 degrees 30 minutes 53 seconds West 505.39 feet; thence leaving said south line and following on the old right-of-way of Fullerton Pike the following three (3) courses: (1) North 01 degrees 09 minutes 42 seconds West 57.41 feet; thence (2) South 89 degrees 16 minutes 53 seconds West 488.72 feet; thence (3) North 69 degrees 50 minutes 09 seconds West 215.25 feet to the east right-of-way line of State Road 37; thence following said east right of way 834.38 feet along a 5584.58 foot radius curve to the right whose chord bears North 20 degrees 08 minutes 28 seconds West 833.61 feet to the POINT OF BEGINNING; thence continuing on said east right of way 266.36 feet along a 5584.58 foot radius curve to the right whose chord bears North 14 degrees 29 minutes 40 seconds West 266.33 feet; thence leaving said east right-of-way, North 69 degrees 14 minutes 58 seconds East 65.38 feet; thence 99.33 feet along a 75.00 foot radius curve to the right whose chord bears South 69 degrees 47 minutes 12 seconds East 92.23 feet; thence South 19 degrees 19 minutes 25 seconds East 128.66 feet; thence 90.65 feet along a 100.00 foot radius curve to the right whose chord bears South 19 degrees 43 minutes 29 seconds West 90.65 feet; thence South 65 degrees 29 minutes 03 seconds West 102.22 feet to the POINT OF BEGINNING, containing 0.83 acres more or less.

**Exhibit "A"**  
**"Karst Easement B"**

Project Number: 4900

LEGAL DESCRIPTION:

A part of the Southwest Quarter of Section 18, Township 9 North, Range 1 West, in Monroe County, Indiana, more particularly described as follows:

COMMENCING at the southeast corner of said quarter section; thence South 89 degrees 30 minutes 53 seconds West 885.32 feet on the south line of said quarter section to the southeast corner of Bill C. Brown Trust Fullerton Pike (Instrument #2008006074, in the Office of the Recorder, Monroe County, Indiana), thence leaving said south line and following east line of said property North 00 degrees 01 minutes 11 seconds East 2628.76, thence leaving said east line and following north line of said property South 89 degrees 56 minutes 28 seconds West 90.98 feet, thence leaving said north line, South 04 degrees 21 minutes 56 seconds West 231.89 feet, thence South 41 degrees 22 minutes 46 seconds West 96.09 feet to the POINT OF BEGINNING; thence North 54 degrees 42 minutes 31 seconds west 239.53 feet; thence South 40 degrees 17 minutes 55 seconds West 113.89 feet; thence South 42 degrees 50 minutes 38 seconds East 237.24 feet; thence North 41 degrees 22 minutes 46 seconds East 163.15 feet to the POINT OF BEGINNING, containing 0.75 acres more or less.



**Exhibit "A"**  
**"Karst Easement C"**

Project Number: 4900

LEGAL DESCRIPTION:

A part of the Southwest Quarter of Section 18, Township 9 North, Range 1 West, in Monroe County, Indiana, more particularly described as follows:

COMMENCING at the southeast corner of said quarter section; thence South 89 degrees 30 minutes 53 seconds West 885.32 feet on the south line of said quarter section to the southeast corner of Bill C. Brown Trust Fullerton Pike (Instrument #2008006074, in the Office of the Recorder, Monroe County, Indiana), thence leaving said south line and following east line of said property North 00 degrees 01 minutes 11 seconds East 2628.76, thence leaving said east line and following north line of said property South 89 degrees 56 minutes 28 seconds West 227.30 feet to the POINT OF BEGINNING; thence continuing along said north line South 89 degrees 56 minutes 28 seconds West 123.29 feet; thence South 34 degrees 53 minutes 29 seconds East 148.62 feet; thence North 55 degrees 47 minutes 03 seconds East 102.05 feet; thence North 35 degrees 30 minutes 02 seconds West 79.41 feet to the POINT OF BEGINNING, containing 0.27 acres more or less.

**Exhibit "A"**  
**"Karst Easement D"**

Project Number: 4900

**LEGAL DESCRIPTION:**

A part of the Southwest Quarter of Section 18, Township 9 North, Range 1 West, in Monroe County, Indiana, more particularly described as follows:

COMMENCING at the southeast corner of said quarter section; thence South 89 degrees 30 minutes 53 seconds West 885.32 feet on the south line of said quarter section to the southeast corner of Bill C. Brown Trust Fullerton Pike (Instrument #2008006074, in the Office of the Recorder, Monroe County, Indiana), thence leaving said south line and following east line of said property North 00 degrees 01 minutes 11 seconds East 2628.76, thence leaving said east line and following north line of said property South 89 degrees 56 minutes 28 seconds West 90.98 feet, thence leaving said north line, South 04 degrees 21 minutes 56 seconds West 143.21 feet to the POINT OF BEGINNING; thence South 52 degrees 42 minutes 22 seconds West 131.34 feet; thence South 37 degrees 12 minutes 37 seconds East 80.78 feet; thence North 41 degrees 22 minutes 46 seconds East 73.95 feet; thence North 04 degrees 21 minutes 56 seconds East 88.69 feet to the POINT OF BEGINNING, containing 0.17 acres more or less.

**Exhibit "A"**  
**"Karst Easement E"**

Project Number: 4900

**LEGAL DESCRIPTION:**

A part of the Southwest Quarter of Section 18, Township 9 North, Range 1 West, in Monroe County, Indiana, more particularly described as follows:

COMMENCING at the southeast corner of said quarter section; thence South 89 degrees 30 minutes 53 seconds West 885.32 feet on the south line of said quarter section to the southeast corner of Bill C. Brown Trust Fullerton Pike (Instrument #2008006074, in the Office of the Recorder, Monroe County, Indiana), thence leaving said south line and following east line of said property North 00 degrees 01 minutes 11 seconds West 610.40 feet, thence leaving said east line South 86 degrees 18 minutes 32 seconds West 320.63 feet to the POINT OF BEGINNING; thence North 02 degrees 01 minutes 59 seconds West 131.01 feet; thence South 88 degrees 52 minutes 18 seconds West 123.52 feet; thence South 02 degrees 30 minutes 11 seconds East 120.91 feet; thence South 86 degrees 24 minutes 33 seconds East 123.11 feet to the POINT OF BEGINNING, containing 0.36 acres more or less.



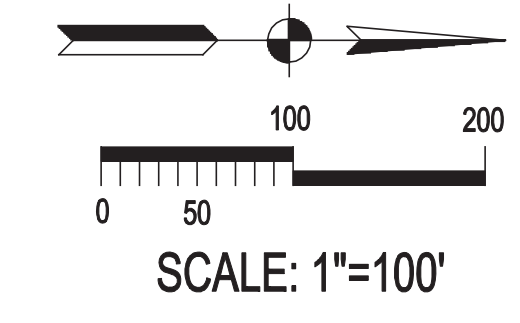

Smith Brehob & Associates, Inc.  
 453 S. Claritz Boulevard  
 Bloomington, Indiana, 47401  
 Telephone: (812) 336-6536  
 Fax: (812) 336-0513  
 Web: <http://smilbrehob.com>



CERTIFICATION DATE  
 / /

JOB TITLE  
**BILL C. BROWN TRUST**  
**FULLERTON PIKE**  
**BLOOMINGTON, INDIANA**

REVISIONS	BY	DATE

DESIGNED <b>JL</b>	DRAWN <b>WDW</b>	CHECKED <b>WDW</b>	DATE
-----------------------	---------------------	-----------------------	------

JOB NUMBER <b>4900</b>
SHEET <b>2 OF 7</b>
DATE <b>03/13/15</b>

EXISTING TOPOGRAPHY

**TOPOGRAPHIC LEGEND**

- 1' CONTOUR INTERVAL      - - - - -
- 5' CONTOUR INTERVAL      - - - - -
- FLOW LINE      - - - - -
- EDGE OF WATER      - - - - -
- SPOT ELEVATION      123.45
- TEST BORING      ⊕
- BENCHMARK      ⊕
- CONCRETE MONUMENT      ⊕
- GPS MONUMENT      ⊕
- IRON PIPE MONUMENT      ⊕
- IRON ROD MONUMENT      ⊕
- RAILROAD SPIKE      ⊕
- REBAR w/ PLASTIC CAP      ⊕
- STONE MONUMENT      ⊕
- STONE MONUMENT w/ "X"      ⊕
- SIGN      ⊕
- TELEPHONE POLE      ⊕
- CONIFEROUS TREE      ⊕
- DECIDUOUS TREE      ⊕
- SOIL BORING      ⊕

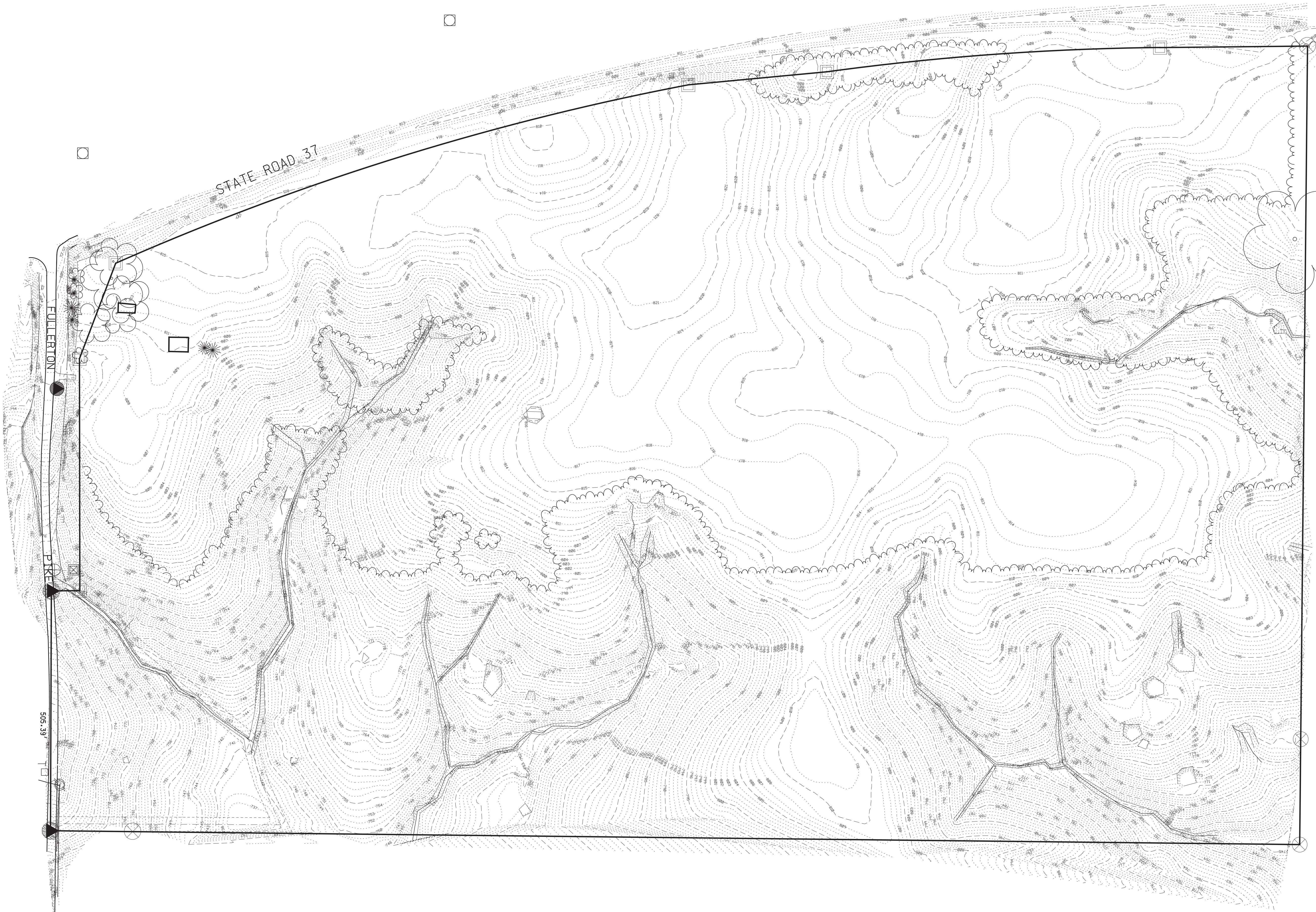



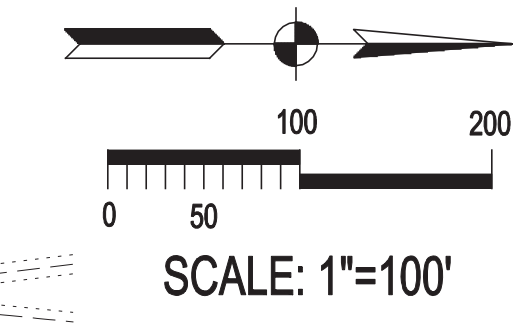

Smith Breth & Associates, Inc.  
 453 S. Clairitz Boulevard  
 Bloomington, Indiana, 47401  
 Telephone: (812) 336-6536  
 Fax: (812) 336-0613  
 Web: <http://smibbreth.com>

CERTIFICATION DATE  
 / /

JOB TITLE  
**BILL C. BROWN TRUST**  
**FULLERTON PIKE**  
**BLOOMINGTON, INDIANA**

REVISIONS	BY	DATE

DESIGNED BY  
**WDW**

CHECKED BY  
**WDW**

DATE

JOB NUMBER  
**4900**

SHEET  
**3** OF **7**

DATE  
**03/13/15**

GRADING PLAN

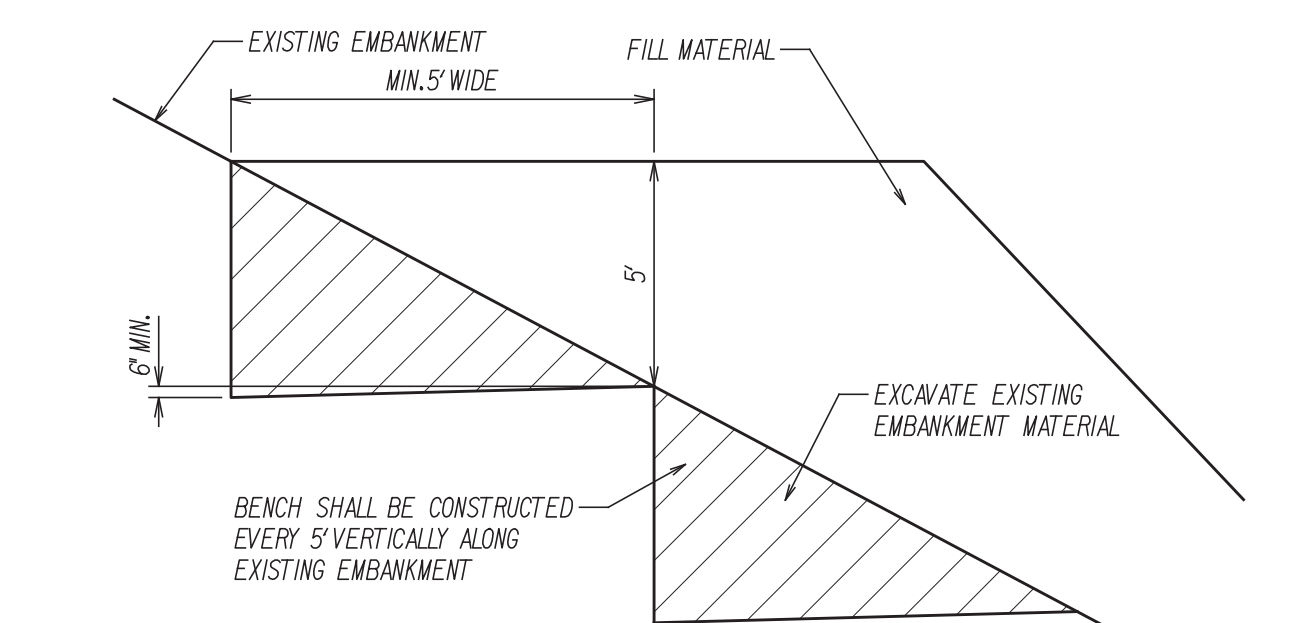

**BENCHING DETAIL FOR STABILITY BERM**  
 NO SCALE



- GRADING & EROS. CTRL LEGENDS**
- PROPOSED 1' CONTOUR
  - PROPOSED 5' CONTOUR
  - PROPOSED SPOT ELEVATION
  - SOIL BORING
  - RIP-RAP
  - SILT TRAP
  - INLET PROTECTION
  - DETENTION BASIN
  - STRAW BALE DAM
  - ROCK CHECK DAM
  - PAVED SIDE DITCH
  - DIVERSION DITCH
  - TREE PROTECTION FENCE
  - FLOOD LINE
  - FLOW LINE
  - GRADING LIMITS
  - SEDIMENT BASIN
  - SILT FENCE

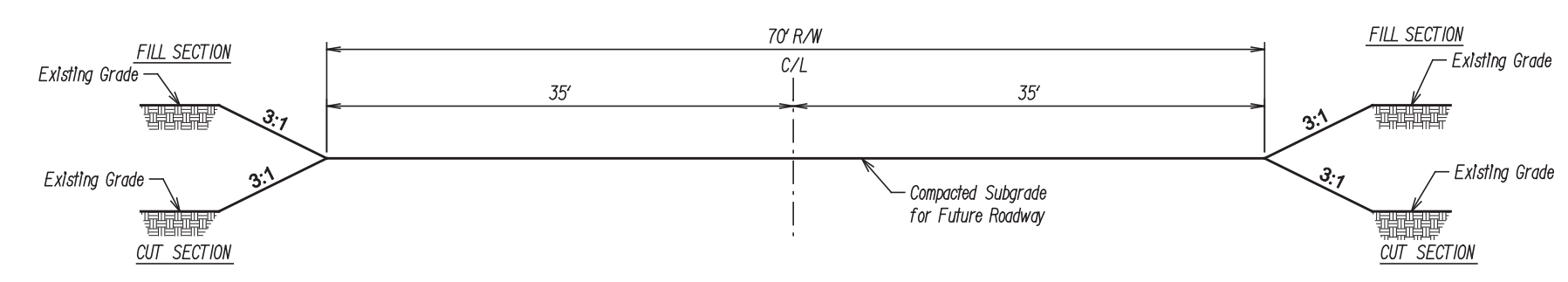

**TYPICAL CROSS SECTIONS FOR FUTURE ROADWAY**  
 NO SCALE

- GRADING NOTES**
- 100YR. F.E.L. = IF SHOWN ON THE PLANS, = 100YR. FLOOD ELEV.
  - GRADING LIMITS: IF SHOWN ON THE PLANS, INDICATE THE LINE AT WHICH THE PROPOSED GRADING MEETS THE EXISTING GRADE AND THE EDGE OF THE AREA THAT SHOULD BE DISTURBED DURING THE CONSTRUCTION PROCESS.
  - PROPOSED SPOT ELEVATIONS, IF SHOWN, ARE AT FINISH GRADE UNLESS NOTED OTHERWISE ON THE PLANS



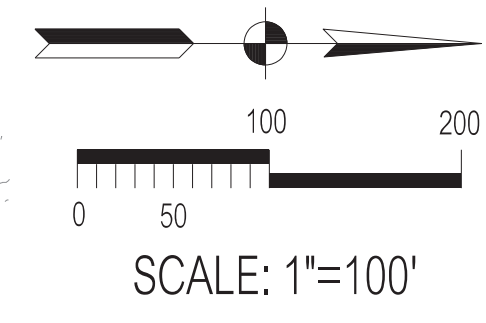
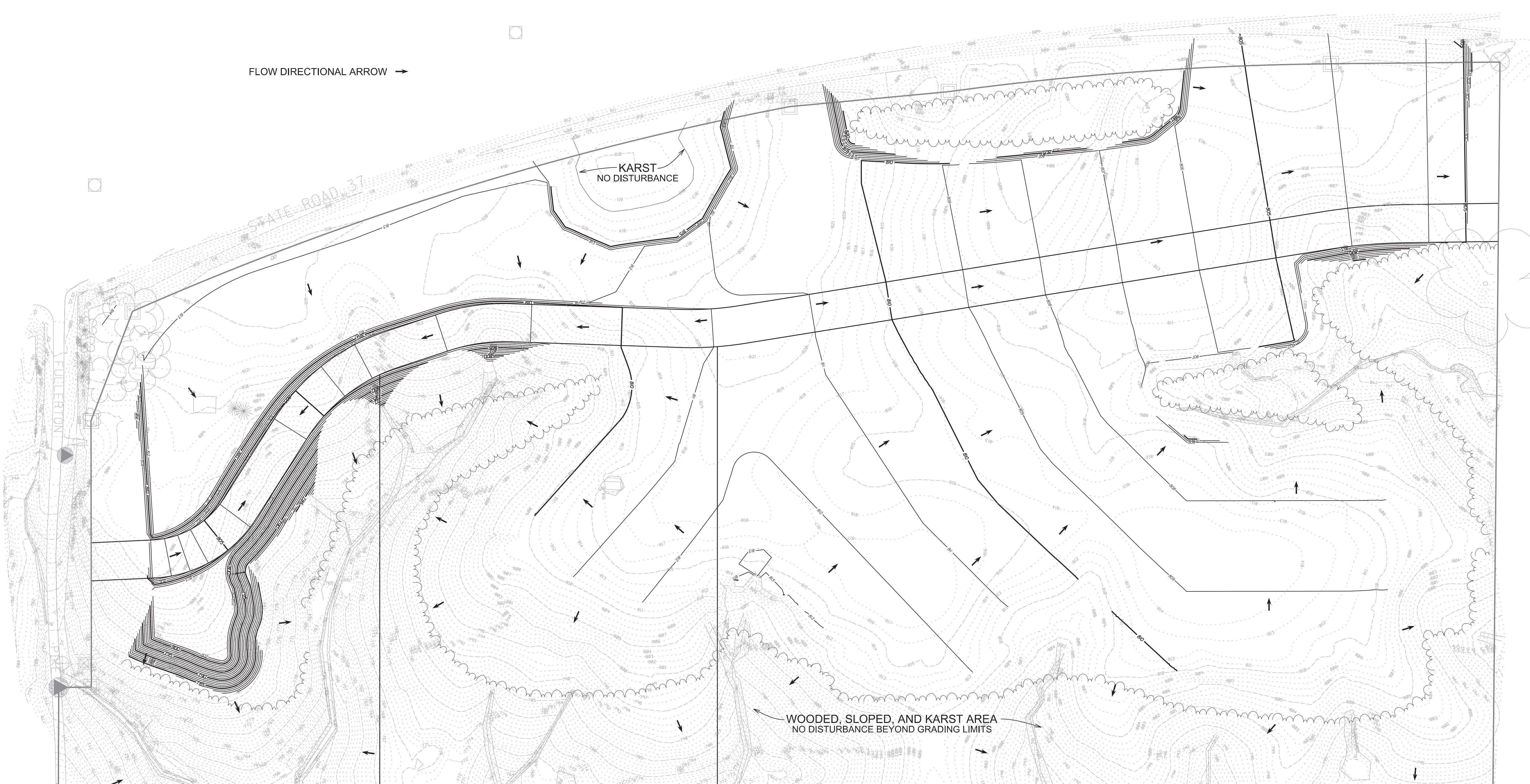

Smith Brubaker & Associates, Inc.  
 453 S. Claitor Boulevard  
 Bloomington, Indiana 47401  
 Telephone: (812) 336-6536  
 Fax: (812) 336-0613  
 Web: http://smithbrubaker.com



CERTIFICATION DATE  
 / /

JOB TITLE  
**BILL C. BROWN TRUST**  
**FULLERTON PIKE**  
**BLOOMINGTON, INDIANA**

**SEC. A CONSTRUCTION PLAN ELEMENTS**

- A2 - Recorded Final Plat  
Not applicable. No legal subdivision of land is occurring as part of this project.
- A3 - Narrative describing nature and purpose of project  
The parcel of land described in this application is anticipated to be future commercial and industrial development. The property lies on the northeast corner of West Fullerton Pike and the future I69 where an interchange will be constructed over the next several years. The work proposed with this application is for mass grading and erosion control measures only. The site will be cut down several feet where possible and the excavation utilized as embankment for the ongoing I69 project.
- A4 - Vicinity Map  
A vicinity map is shown on Sheet 1.
- A5 - Legal Description  
Please see title sheet
- A6 - Location of lots and proposed improvements  
No lots are being created. The location of the project can be seen on the location map shown on Sheet 1.
- A7 - Hydrologic Units Code (HUC14)  
05120208090010
- A8 - Notation of any State or Federal water quality permits  
No State or Federal water quality permits are required for this project other than the IDEM Storm Water NPDES NOI.
- A9 - Specific points where storm water discharge leaves the site  
Noted on the drainage map.
- A10 - Location & name of all wetlands, lakes & water courses on and adjacent to the site - (if they exist).  
No wetlands were noted on the National Wetlands Inventory mapper within the project area. Water courses are noted on the drainage map.
- A11 - Identification of all receiving waters  
Noted on the drainage map. Discharge leaves the site via sheet flow to limestone quarry areas within the Clear Creek watershed.

- A12 - Identification of potential discharges to ground water  
There is one known sinkhole on the property. It is noted on the drainage map.
- A13 - 100 yr floodplains, floodways, and flood fringes - if they exist  
There are no mapped floodways within the project area, based on the FEMA FIRM for the area.
- A14 - Pre & Post construction estimates of peak discharge (10 yr)  
Using the SCS Runoff Method and TR55, the pre-development discharge is approximately 28 cfs and the post-development is approximately 18 cfs due to the reduction in land slope.
- A15 - Adjacent land use, including upstream watershed  
The use of adjacent land is visible on Sheet 1. Adjacent land to the project is either undeveloped land that is composed of open fields or wooded area or is used for the NSWC purposes that is undisclosed.
- A16 - Location & approximate boundary of all disturbed areas  
All disturbed areas are shown on Sheet 2 as a stippled pattern to denote areas requiring re-vegetation after construction or through a hard surfaced area such as pavement.
- A17 - Identification of existing vegetative cover  
Noted on Sheet 1. The existing vegetation consists of farm and pasture land with trees along the north, east and south perimeter of the property.
- A18 - Soils map including soil descriptions and limitation  
Soils map is shown on Sheet 1. Soil types indicated below:  
BdB Bedford Silt Loam, 2 to 6 percent slopes  
CxD Caneyville Silt Loams, 12 to 18 percent slopes  
Cb Caneyville-Hagerstown Silt Loam, Karst  
CrC Crider Silt Loam, 6 to 12 percent slopes  
HdD Hagerstown Silt Loam, 12 to 18 percent slopes
- A19 -Proposed storm water system location, size & dimension  
No new permanent storm water collection systems or control systems are being proposed or are required. Culverts will be placed within the diversion ditches to convey runoff underneath the access road. Their locations and sizes are shown on Sheet 5.
- A20 - Plans for off-site constr. Activities assoc. w/project  
Not applicable. No offsite work is proposed or required.

- A21 - Proposed stockpile and/or borrow/disposal area locations  
A stockpile location is shown in Sheet 5.
  - A22 - Existing topography  
The existing topography is shown on Sheet 3.
  - A23 - Proposed final topography  
The proposed final topography is shown on Sheet 3.
- SECTION B STORMWATER POLLUTION PREVENTION PLAN - CONSTRUCTION COMPONENT**
- B1 - Description of potential pollutant sources assoc. w/constr.  
Pollutants associated with this project will be minimal due to the scope of the project. Possible pollutants associated with construction include trucks used for delivery of fuel and maintenance of vehicles. Some pollutants associated with construction include grit and sediment due to grading and clearing, rust and brake dust from the construction vehicles and various fluids that may be used to lubricate or maintain construction equipment. Other pollutants may be possible, but are not foreseeable at this time. The SBA 2015 Specifications cover recommendations used for spills and other groundwater contaminants due to construction.
  - B2 - Sequence describing storm water quality measures implementation relative to land disturbing activity  
Indicated in the Erosion Control Notes on Sheet 5.
  - B3 - Stable construction entrance location and specifications  
The location is shown on Sheet 5. Specifications are shown on Sheet 6 and details are located on Sheet 7.
  - B4 - Sediment control measures for sheet flow  
Silt fence will be utilized. Diversion ditches, temporary sediment basins and traps will be utilized throughout the site. Locations are shown on Sheet 5. Specifications are shown on Sheet 6 and details are located on Sheet 7.
  - B5 - Sediment control measures for concentrated flow areas  
Diversion ditches will be used throughout the site to direct runoff to the appropriate sediment basin or trap. Locations are shown on Sheet 5. Specifications are shown on Sheet 6 and details are located on Sheet 7.

- B6 - Storm sewer inlet protection measure location & spec's.  
Not applicable. There are no storm sewer inlets on or adjacent to the project location.
- B7 - Runoff control measures  
Diversion ditches will be used throughout the site and will direct runoff to the appropriate sediment basin or trap within the site. The locations of such measures are shown on Sheet 5. Specifications are shown on Sheet 6 and details are located on Sheet 7.
- B8 - Storm water outlet protection specifications  
Not applicable. No new storm water culverts or storm sewer systems will be installed for this project.
- B9 - Grade stabilization structure locations and specifications  
Not applicable. Retaining walls or other grade stabilization features are not included for this project.
- B10 - Location, dimensions, specifications, & constr. Details of each storm water quality measure  
Storm water quality measures and erosion control measures are shown on Sheet 5. Specifications are shown on Sheet 6 and details are located on Sheet 7.
- B11 - Temporary surface stabilization methods appropriate for each season  
Locations requiring seeding will be the disturbed areas shown on Sheet 5. Specifications for such are shown on Sheet 6.
- B12 - Permanent surface stabilization specifications  
All disturbed areas other than hard surface pavement areas will be finished lawn seeded. The specifications for which are noted by reference on Sheet 6.
- B13 - Material handling and spill prevention plan  
Specifications for material handling and spill prevention are noted on Sheet 6
- B14 - Monitoring and maintenance guidelines for each proposed storm water quality measure  
Specifications for temporary erosion control devices are noted on Sheet 6.
- B15 - Erosion & sediment control specifications for individual building lots  
Not applicable. No single family building lots are being created.

**SEC. C STORMWATER POLLUTION PREVENTION PLAN - POST CONSTRUCTION**

- C1 - Description of pollutants & their sources associated with the proposed land use  
Possible pollutants associated with a project such as this will be minimal and may include grit, dust or fluids from the vehicles accessing the project area for testing or maintenance of the facility.
- C2 - Sequence describing storm water quality measures implementation  
Storm water quality implementation will consist of re-establishment of vegetative cover. Seeding sequence is described in the Erosion Control Notes on Sheet 3.
- C3 - Description of proposed post-construction storm water quality measures  
Post construction storm water quality will consist of re-establishment of vegetative cover.
- C4 - Location, dimensions, specifications, and construction details of each storm water quality measure  
Post construction storm water quality will consist of re-establishment of vegetative cover. All disturbed areas within the site not including the road will require permanent seeding as shown on sheets 5. Specifications are noted by reference on Sheet 6.
- C5 - Description of maintenance guidelines for post construction storm water quality measures  
Not applicable. Areas may require mowing or re-seeding as no post-construction water quality measures other than re-establishment of vegetative cover are proposed or required. Future maintenance of lawn areas will be at the discretion of the Owner and subject to any maintenance program currently in place or implemented in the future.

BY	DATE	REVISIONS
SLS	08/03/15	

APPROVED	DATE
WDW	
DISCOVERED	
WDW	
CHECKED	

JOB NUMBER  
**4900**

SHEET  
**4 OF 7**

DATE  
 03/13/15

**DRAINAGE MAP**



**BLOOMINGTON PLAN COMMISSION  
STAFF REPORT  
LOCATION: 300 S. SR 446**

**CASE #: ZO-25-20  
DATE: December 14, 2020**

**PETITIONER:** Bill C. Brown Revocable Trust  
300 S. State Road 446, Bloomington

**CONSULTANT:** Michael L. Carmin.  
116 W. 6<sup>th</sup> Street, Bloomington

**REQUEST:** The petitioner is requesting to rezone 10.097 acres from PUD (70 – Century Village) to (MC) Mixed-use Corridor. A waiver of the required 2<sup>nd</sup> hearing is also requested.

**BACKGROUND:**

<b>Area:</b>	10.0097 acres
<b>Current Zoning:</b>	PUD (70 – Century Village) and (21 – Baker/Stephens)
<b>Comprehensive Plan Designation:</b>	Urban Corridor
<b>Existing Land Use:</b>	Vacant
<b>Proposed Land Use:</b>	Undetermined
<b>Surrounding Uses:</b>	North – Commercial/Dwelling, Multifamily South – Dwelling, Multifamily East – Communication Tower/Commercial/ Dwelling, Single-family West – Commercial/Restaurant

**REPORT:** The 10.0097 acre property is located at the southwest corner of E. 3<sup>rd</sup> St. and State Road 446. The properties are currently zoned (PUD) Planned Unit Development; a majority of the site is within PUD 70 (Century Village) which was originally approved in 1975 as PCD-10-75. The remainder of the site is within PUD 21 (Baker/Stephens). The developed portions of the PUDs (Lots 1, 2, 3, and 5, as well as Century Suites Phase I-A, and Phase I-B) are not included in this petition. The excluded portions will remain within PUD 70 and PUD 21. The properties to the north across E. 3<sup>rd</sup> Street are zoned MC and are currently developed with mixture of commercial and multifamily dwelling units and are home to Summerhouse. The properties to the south are zoned RM and PUD and have both been developed with multifamily dwelling units. The properties to the west are zoned PUD and have been developed with a multitenant center and restaurant. The adjacent properties to the east are zoned within PUD 70 and have been developed with a communication tower, hotel, and offices. The property fronts along E. 3<sup>rd</sup> St and S. SR 446.

The petitioner is requesting to rezone the property from PUD to (MC) Mixed-Use Corridor. No development plan is being requested at this time. The properties being proposed to be rezoned are largely undeveloped with the exception of two surface level parking areas. Roughly 5 acres of the current Century Village PUD have been excluded from the proposed rezone and will remain a PUD. The proposed rezone would allow for all uses allowed in the MC district to be used on the site.

A conceptual site plan has been submitted with the petition, but is representative and seeks to show what a potential development would look like once the area is rezoned. While the petitioner has a conceptual site plan, any uses allowed in the MC district would be allowed on the site. Any future

developments that met the threshold for a major site plan review would be required to undergo further Plan Commission review. The current conceptual site plan shows a potential development which features four multifamily buildings with a mixture of 1 and 2 bedroom units proposed, for a total of 164 units. Ground floor non-residential units are shown along E. 3<sup>rd</sup> St. The conceptual site plan also shows a planned 32,000 square foot self-storage building at the southern end of the site. All of the uses shown in the conceptual plan are allowed in the MC district.

---

**COMPREHENSIVE PLAN:** The majority of this site is designated as ‘Urban Corridor’ with some ‘Neighborhood Residential’ on the southern rear portion. The lines and edges in the Comprehensive Plan are intended to be fluid, so as to be flexible as areas in the City develop. Given the existing development on and around the site, the Department feels that ‘Urban Corridor’ is the most appropriate district to analyze this proposal. The Comprehensive Plan notes the following about the intent of the ‘Urban Corridor’ area and its redevelopment:

- *Designed to transform strip retail and commercial corridors along major roadways into a more urban mixed-use district that will serve as an appropriate transition from higher, more intensive uses to other districts, Focus Areas, and regional activity centers.*
- *Integrating multifamily residential uses into existing retail and commercial areas within the district can apply a mixed-use approach within individual buildings sites or between adjacent properties.*
- *It is intended to incorporate a balance of land uses by taking advantage of the proximity to other land uses and urban services.*
- *The district is expected to change by incorporating mixed uses and increasing activity.*
- *Buildings should be developed with minimal street setbacks, with parking located behind the building, and with an emphasis on minimizing pedestrian obstacles to accessing businesses.*
- *Development and redevelopment within the district is particularly suited to high-density residential and mixed residential/commercial use and taller building heights, with the possibility of three or four-story buildings.*

The proposed rezoning from PUD to MC will allow the site to more easily achieve the intent of the Urban Corridor designation. The properties front along two major roadways (E. 3<sup>rd</sup> St. and S. SR 446), but the current PUD does not allow for the increased residential density that the Comprehensive Plan calls for in this area. The MC district was intended to be along major arterial and collector corridors at a larger scale than other commercial zoning districts. The MC district is intended to accommodate medium-scaled developments with a mix of retail, office, and residential uses. The MC district would allow for a greater opportunity for a mixed-use approach to development than the current, commercial focused PUD. The MC district allows for taller buildings than most other base zoning district at 4 stories (not to exceed 50 feet).

---

**20.06.070(b)(3)(E)(i)(1) ZONING MAP AMENDMENT PLAN COMMISSION REVIEW AND RECOMMENDATION:**

[a] The recommendations of the Comprehensive Plan;

**Proposed Finding:** The Comprehensive Plan designates these properties as ‘Urban Corridor’ and ‘Neighborhood Residential.’ The Comprehensive Plan acknowledges that the lines of the Future Land Use map are intended to be fluid, and that when petition sites span multiple



designations, the best suited designation should be identified using the petition details and surroundings. This petition includes five parcels under single ownership that front along two major corridors in the City. Therefore the ‘Urban Corridor’ designation is believed to be the most align with the petition site.

The Comprehensive Plan gives guidance to land use decisions for the ‘Urban Corridor’ that include mixed-use developments at heights and intensities higher than smaller less intense areas of the city. The MC district’s purpose is to “accommodate medium-scaled developments with a mix of storefront retail, professional office, and/or residential dwelling units along arterial and collector corridors at a scale larger than the neighborhood-scale uses accommodated by the MN zoning district.” The MC district is the base zoning district that most closely aligns with the intent and goals of ‘Urban Corridor’ areas of the Comprehensive Plan.

[b] Current conditions and character of structures and uses in each zoning district;

**Proposed Finding:** The site is undeveloped and is in a prime location for a mixture of commercial and residential uses with direct access to two major corridors (E. 3<sup>rd</sup> St. and S. SR 446). The proximity to both major area commercial uses, and multifamily and single-family areas makes this an ideal location for mixed-use development.

[c] The most desirable use for which the land in each zoning district is adapted;

**Proposed Finding:** The most desirable use for this land is to follow the recommendations of the Comprehensive Plan which calls for commercial, higher density residential, and mixed-use developments throughout the ‘Urban Corridor.’ The MC district was intended to allow for a variety of commercial and residential units to be developed throughout. The standards and allowed uses within the MC district would allow for the most desirable uses of this area.

[d] The conservation of sensitive environmental features;

**Proposed Finding:** The properties currently have a tree preservation area on the southeast portion of the site. This area on the site was set aside during the rezone to a PUD. A conditional of approval has been included which will further ensure that the tree preservation area will be maintained in perpetuity.

[e] The conservation of property values throughout the jurisdiction; and

**Proposed Finding:** The rezoning of these portions of PUDs to MC are not anticipated to have any negative impacts on the adjacent property values throughout the jurisdiction.

[f] Responsible development and growth

**Proposed Finding:** The rezoning of this property to MC would allow for mixed-use developments along two major corridors. The MC district was intended to allow for a mixture of uses, including multifamily residential uses, along major corridors. The Comprehensive Plan has identified this area as ideal for a mixture of commercial uses and higher-density residential uses. This location is easily accessed from both E. 3<sup>rd</sup> St. and S. SR 446. This petition would allow for more uses than the current PUDs, and match the goals of the

Comprehensive Plan.

---

**CONCLUSION:** The Department promotes rezoning properties which have been largely undeveloped since 1975. The Comprehensive Plan gives guidance which supports a mixture of uses along major corridors in the city. The Mixed-Use Corridor (MC) district allows for a variety of commercial and residential uses. The petition site fronts along two major corridors (E. 3<sup>rd</sup> St. and S. SR 446), allowing excellent access possibilities for future development. Allowing additional uses, particularly multifamily residential, would allow a site along a heavily traveled portion of the city to be developed in line with the Comprehensive Plan's long term goals of the City.

---

**RECOMMENDATION:** Based on the findings of fact in the report, the Department recommends forwarding this petition to the Common Council with a positive recommendation, and waiving the required second hearing, with the following conditions:

1. A Tree Preservation Easement shall be confirmed by survey and recorded in the Monroe County Recorder's Office as a recordable commitment, and the easement will be in compliance with Unified Development Ordinance easement standards, including but not limited to signage.

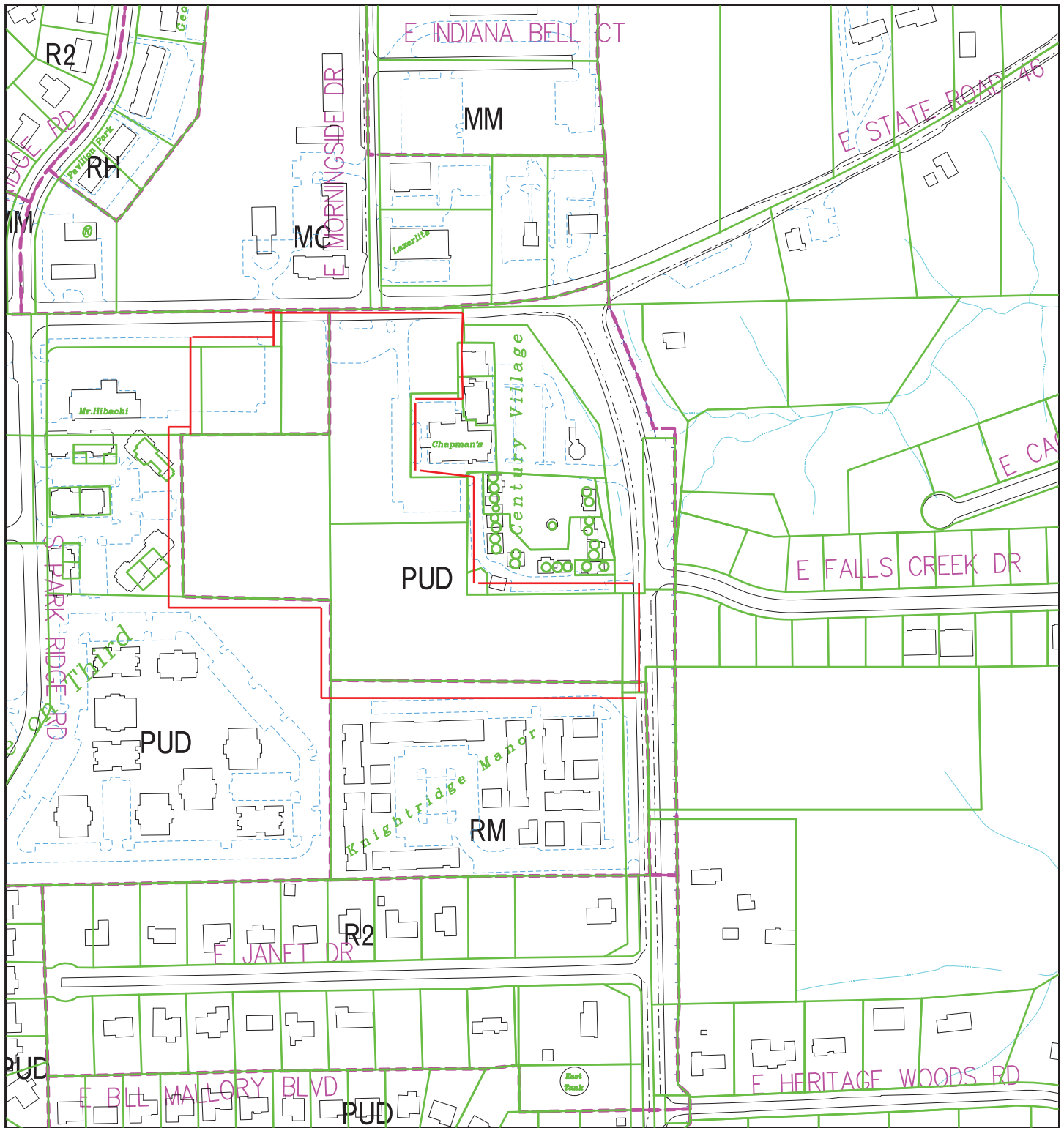

By: roblingr  
11 Dec 20



City of Bloomington  
Planning & Transportation

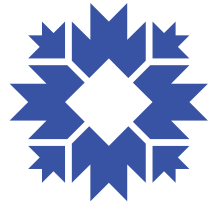

Scale: 1" = 300'

For reference only; map information NOT warranted.





By: roblingr  
11 Dec 20



City of Bloomington  
Planning & Transportation

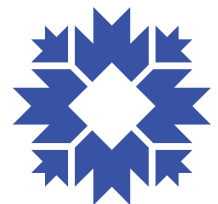

Scale: 1" = 300'

For reference only; map information NOT warranted.



## PETITIONERS' REZONING STATEMENT

Petitioners request for rezoning of the Century Village Planned Unit Development to mixed use – corridor (MC). This petition excludes rezoning Lot 1, Century Village Phase 1 as shown by the plat in Cabinet C in the Envelope 164 (Radio Station Office Building) and the small tract on which the radio station transmission tower was erected.

Uniform development ordinance states the purpose for the MC zone as “intended to accommodate medium-scaled developments with a mix of store front retail, professional office, and/or residential dwelling units along arterial and collector corners at a scale larger than the neighborhood-scale uses accommodated by the MN zoning district.

Current Planned Unit Development Zone. The Century Village II planned unit development was approved on October 1, 2004 as ordinance 04-32. The Century Village PUD encompassed 14.32 acres and identified a list of permitted uses as:

- Assisted Living Facility
- Day Care Centers
- Financial Institutions with a drive thru
- Hotel/Motel
- Office, including medical and professional
- Personal Services (hair care, tanning, etc.)
- Radio/TV Stations
- Retail Sales in enclosed buildings, limited to first floor and five thousand square feet per user
- Banquet Facility
- Restaurants, sit down, with pickup only window for carryout orders being allowed
- Restaurant, limited service
- Group Hub – limited to a minimum of 50% floor area committed to tavern/restaurant area
- Social Services
- Covered Offices

The PUD also permitted multifamily use located on second floor and above and limited to a maximum of fifty units. Site design required access to the development from East 3<sup>rd</sup> Street via single access point with the interior road to Century Village directly aligned with the existing E. Morningside Drive street connection to E. 3<sup>rd</sup> Street. East access to Century Village Complex was authorized two connections at South State Road 446.

PUD Development. The Century Village PUD acreage was subsequently platted and replatted or by amended plats created eleven lots. Seven lots are developed with the following uses:

- Office Buildings (three lots)
- Common Parking and Overflow Parking (two lots)

- Condominiums (Century Suites short-term and transient rentals)
- Restaurant
- Banquet Facility
- Radio Station Office and Transmission Tower

Development Land. The undeveloped lots and undeveloped portions of lots total approximately eleven acres.

Proposed/anticipated future development of the eleven acres includes:

- Multifamily Housing (primarily located on the northern one-half of the development ground in Century Village Complex. The multifamily buildings would be along the E 3<sup>rd</sup> Street frontage.
- Business and personal services offices (first floor use in the multifamily buildings adjacent to E 3<sup>rd</sup> Street frontage)
- Storage/Self-service Units (developed on the southern approximate one-half of the development land/Century Village PUD area). The Storage units would have direct access to South State Road 46.

Adjacent and Surrounding Uses. The Century Village PUD is bordered on the north by E 3<sup>rd</sup> Street/East State Road 46. Uses on the north side of E. 3<sup>rd</sup> Street include a convenience mart/gas station, a multifamily apartment development, a commercial building, an ice cream store and a general contractor trade office. The PUD is bordered on the east by State Road 446. On the east side of 446 is a single-family residential home, undeveloped strip of land, a connecting road at East Fall Creek Drive which extends eastward and is bordered on the north and south side by single-family homes. Adjacent to the south side of Century Village is a multifamily apartment complex. The PUD is bordered to the west by multifamily apartments and a restaurant at the northwest corner of Century Village frontage on E 3<sup>rd</sup> Street.

Environmental Issues. No karst features or environmentally sensitive features or areas are known to exist within Century Village. The eleven acres of development area is primarily open space, vacant land with few trees. The development of the eleven acres in addition to adding a treescape, is expected to preserve all existing specimen trees. On site drainage controls and water quality measures would be developed in conjunction with any further development of the project.

Petitioners' Intent: A planning policy for the City of Bloomington is to examine the existing PUD zones upon adoption of the new Uniform Development Ordinance. The City will examine the existing PUD zones carried forward with the new zoning map and consider appropriate rezonings to identify specific zoning classifications in the new UDO. Prior to development of the remaining eleven acres in the Century Village PUD, petitioners seek to advance the consideration of rezoning of the Century Village PUD to an appropriate zone in accordance with the recently approved UDO. The mixed use corridor zone is the most appropriate zoning classification for the Century Village PUD. The property is located on two corridors – E 3<sup>rd</sup> Street and South State Road 446. The permitted uses in the Century Village PUD are most closely aligned with the uses permitted for the MC zone in accordance with the use table. The



anticipated development for the eleven acres in the Century Village PUD is consistent with the MC table of permitted uses. The development standards applicable to the MC zone are appropriate for the existing developments as well as anticipated development of the eleven acres.

Development would utilize the MC development standards for multifamily housing. It is expected that the development would maintain the current PUD standard for first floor nonresidential use in multifamily buildings along the E 3<sup>rd</sup> Street frontage.

Petitioner requests waiver of second hearing before the Plan Commission.

A handwritten signature in blue ink that reads "Michael L. Carmin". The signature is fluid and cursive, with a horizontal line extending to the right.

Michael L. Carmin  
Attorney for Petitioner

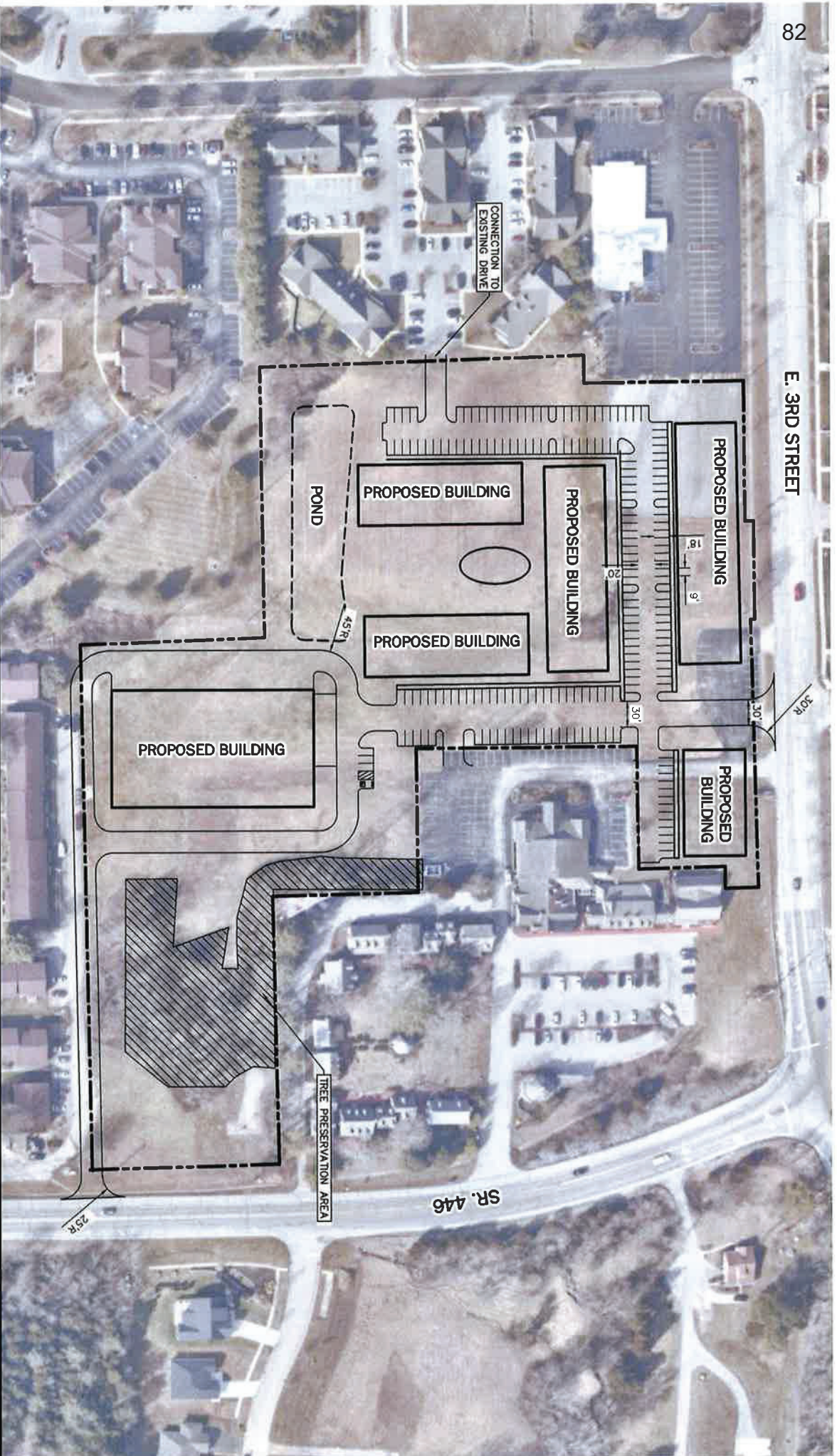

SCALE: 1" = 100'

October 8, 2020

### Site Exhibit

Bloomington Century Village PUD - Rezone  
 E. 3rd Street & SR. 446  
 Bloomington, IN

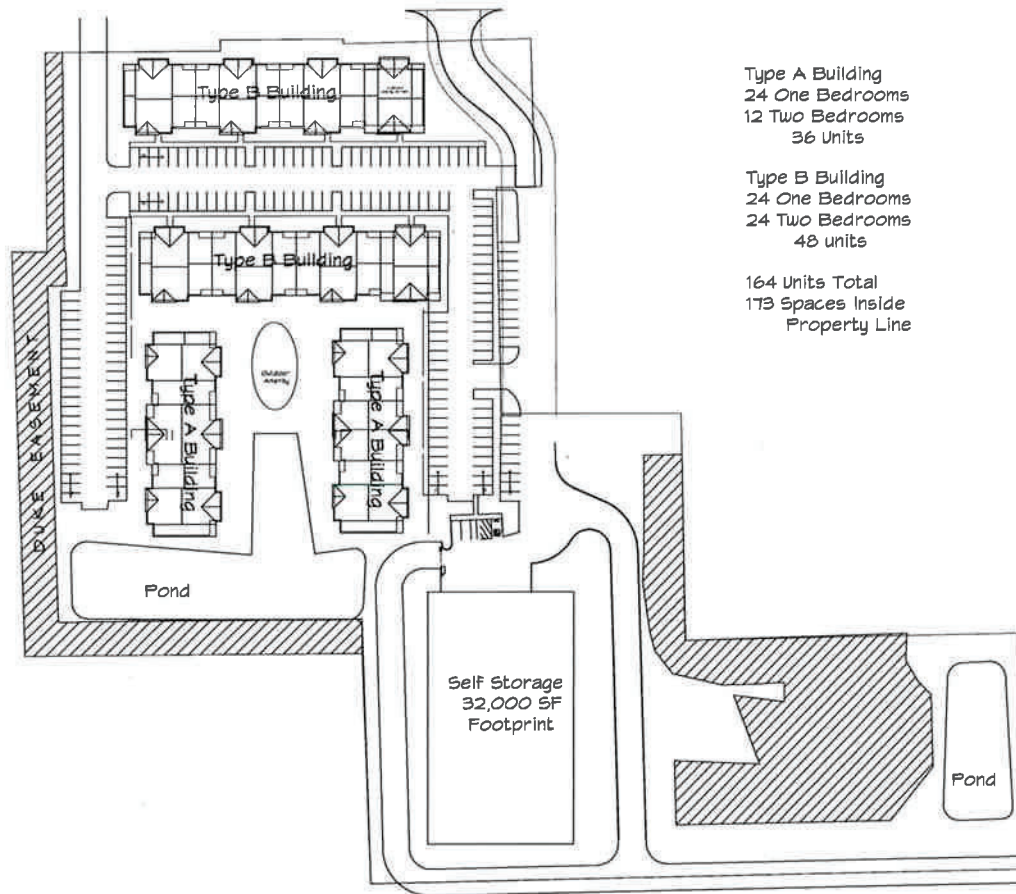

Type A Building  
24 One Bedrooms  
12 Two Bedrooms  
36 Units

Type B Building  
24 One Bedrooms  
24 Two Bedrooms  
48 units

164 Units Total  
173 Spaces Inside  
Property Line



Type A Building  
 24 One Bedrooms  
 12 Two Bedrooms  
 36 units  
  
 Type B Building  
 24 One Bedrooms  
 24 Two Bedrooms  
 48 units  
  
 164 Units Total  
 173 Spaces inside  
 Property Line

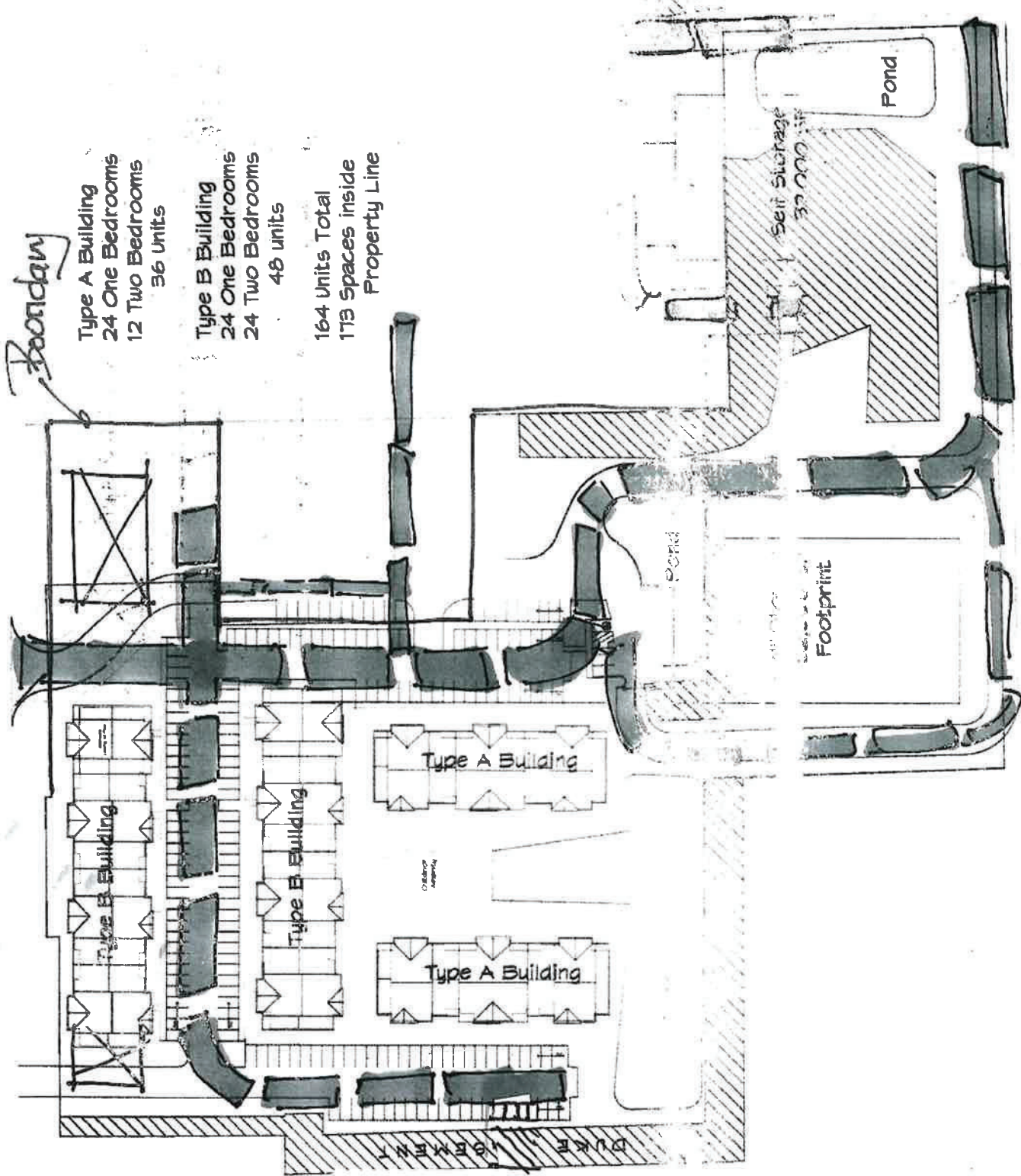



**Front Elevation Concept - Building B**

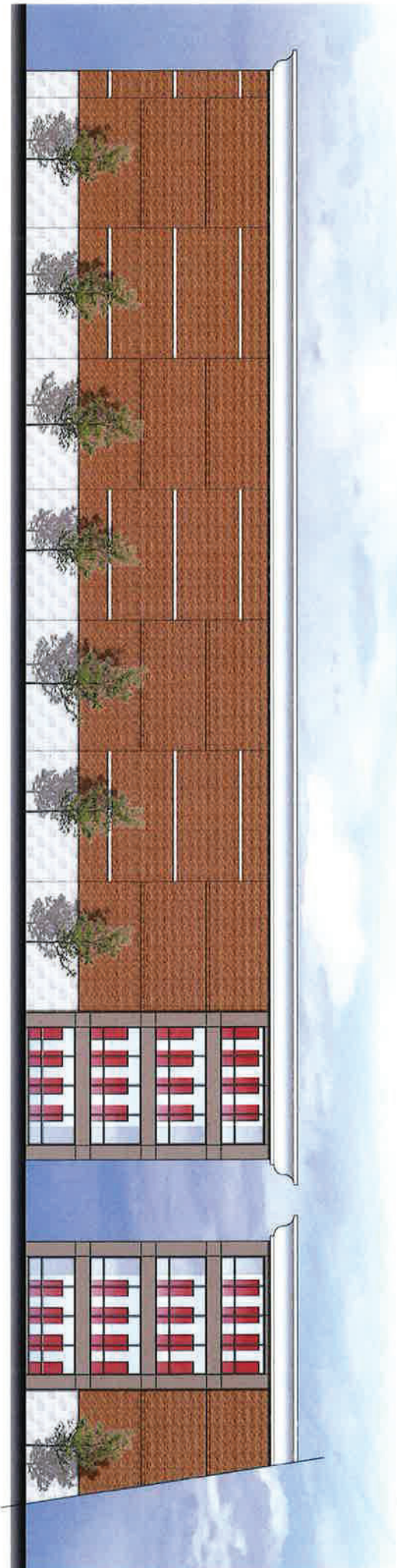

**US Architects**  
(765) 405-1220

A Concept Sketch for  
**Century Village Storage**  
Bloomington, Indiana  
September 2020



**BOSE  
McKINNEY  
& EVANS LLP**

ATTORNEYS AT LAW

**Robert T. Wildman**

Direct Dial: (317) 684-5377

Fax: (317) 223-0377

E-Mail: [RWildman@boselaw.com](mailto:RWildman@boselaw.com)

December 11, 2020

City of Bloomington Plan Commission  
c/o Ryan Robling

Re: Century Village PUD Rezoning

Dear Mr. Robling:

I am writing on behalf of Sound Management, LLC ("Sound Management"). Sound Management is the owner of Century Village Phase 1, Lot 1 which contains a broadcast office and studio for its radio stations. It also leases a .058 acre parcel in Century Village for its broadcast tower. Call, LLC, an affiliated entity, actually owns the tower. There is an easement for a transmission line that runs between the broadcast studio and the tower. Sound Management's predecessor, University Broadcasting Company, LLP, acquired the property and tower in 1996 from a prior radio operator. Its broadcast operations and the tower are specifically permitted uses in the Century Village PUD. Sound Management has made a substantial investment in its assets and operation and anticipates continuing operations from Lot 1 and the broadcast tower that is located in the Century Village PUD for years to come.

We are aware that Bill Brown has initiated a rezoning petition to covert the Century Village PUD (exclusive of Lot 1 and the broadcast tower) to an appropriate zone under the recently adopted City of Bloomington Unified Development Ordinance. Sound Management declined to join the rezoning petition as to Lot 1 and the tower site. We understand that in all of the possible zones in the new zoning ordinance, the communication tower is permitted only as a conditional use. As you can imagine operation of the broadcast tower as it currently exists is critical to the continued operation of Sound Management's business.

While Sound Management, LLC does not object to Mr. Brown's petition, it does object to any change which would restrict Sound Management's current operations or cause the broadcast tower to be a conditional use now or in the future. It is not reasonable to expect Sound Management to voluntarily or intentionally subject its use of the property to a zoning change that imposes conditional use standards on its business critical communication tower. Sound Management, LLC and Call, LLC have far too much invested in the radio station's site and communication tower as a permitted use.

Sincerely,

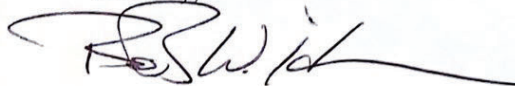

Robert T. Wildman

3976822\_1