

CITY OF BLOOMINGTON



PLAT COMMITTEE

February 8, 2021 @ 4:00 p.m.

Via Zoom:

<https://bloomington.zoom.us/j/91659591372?pwd=ZGg4RzBNWkZST3pXWHA3K2hqSk5TUT09>

**CITY OF BLOOMINGTON
PLAT COMMITTEE
February 8, 2021 at 4:00 p.m.**

❖ **Virtual Meeting:**

<https://bloomington.zoom.us/j/91659591372?pwd=ZGg4RzBNWkZST3pXWHA3K2hqSk5TUT09>

ROLL CALL

MINUTES TO BE APPROVED: None at this time

REPORTS, RESOLUTIONS, AND COMMUNICATIONS:

DP-11-02 Butcher Subdivision Sidewalk Waiver

PETITIONS:

DP-28-20 **Trinitas Development**
1550 N. Arlington Park Drive
Request: Secondary plat approval of 45 single-family lots, one common area lot,
and four multifamily lots.
Case Manager: Eric Greulich

<https://arcg.is/j4i9q>

**BLOOMINGTON PLAN COMMISSION
STAFF REPORT
Location: 1550 N. Arlington Park Drive**

**CASE #: DP-28-20
DATE: February 8, 2021**

PETITIONER: Trinitas Development
201 Main Street Suite 1000 Lafayette IN

CONSULTANTS: Bynum Fanyo & Associates, Inc.
528 N. Walnut Street, Bloomington

REQUEST: The petitioner is requesting secondary plat approval of 45 single family lots, one common area lot, and four multifamily lots.

BACKGROUND:

Area: 40.75 acres
Current Zoning: Planned Unit Development
GPP Designation: Neighborhood Residential
Existing Land Use: Undeveloped
Proposed Land Use: Dwelling, Multi-Family/Single Family Residential
Surrounding Uses: North – Dwelling, Single-Family
West – State Road 37 / Interstate 69
East – Dwelling, Single-Family
South – Office / Industrial Use

REPORT: The property is located north of West 17th Street at the north end of Arlington Park Drive. The property is north of offices and industrial development and a multifamily development that maintain frontage on 17th Street and is bounded by single family lots to the north and east and State Road 37/Interstate 69 to the west. The site received approval of a preliminary plan and district ordinance last year under case #PUD-36-19 and final plan approval and primary plat approval under PUD-12-20.

The petitioner is now requesting secondary plat approval to allow the platting of 45 single family lots, one common area lot (Lot #46), and four multi-family parcels. Approximately 13.89 acres of preservation will also be platted and set aside in a conservation easement. Access to the site will come from the two public road connections to 17th Street to the south and a connection to Arlington Road to the east. All of the proposed connections are shown in dedicated right-of-way with this plat. The proposed secondary plat has not deviated from the approved primary plat. This project would be constructed in all one phase.

The petition still involves 4 areas of development and land uses-

Area A- This area will be developed consistent with the R4 zoning district in an area of 45 lots on 7.61 acres. The lots are approximately 40'x120' and will be dedicated to the City to help meet the diverse housing needs of the Community. The area must be graded with all roads and infrastructure installed before acceptance by the City. The lots have been designed in a grid-like pattern and a majority of them will utilize alley access along the rear of the lots. A 50' wide buffer and conservation area has been shown along the east sides of Area C between this PUD and the adjacent residential houses. All lots will front on a public street. This area will be governed by the standards of the R4 district and will allow for R4 uses which include attached single family and

plexes in order to give the most flexibility toward possible development. The City is in the process of seeking input from potential developers on a creative design for the space. The petitioner will only be required to have the site infrastructure ready before the area can be developed.

Area B- This area will be developed with 114 units and 255 bedrooms in a mix of duplexes and townhomes on 7.11 acres. The proposed density utilizing DUEs was approved at 13 units per acre, which this petition meets. There will be 76 private parking spaces for the 255 bedrooms in this area, which equals 0.3 parking spaces per bedroom. The interior roads in this area will be private, but have been designed with parallel, on-street spaces rather than perpendicular parking that was shown with the preliminary plan. This is a design improvement that was encouraged by the Common Council. There are sidewalks shown along both sides of the street, however the tree plot is proposed to be located behind the sidewalk in order to minimize impacts to the adjacent riparian buffers and wetlands. Since these are private drives, the Department finds this to be an appropriate design in this area only to minimize environmental impacts.

There is an intermittent stream with associated riparian buffer that runs through part of this property as well as several wetlands that are being set-aside in conservation easements. There are 3 road crossings through the riparian buffer areas, however those are allowed and were approved with the preliminary plan. There will not be any disturbance in the required wetland conservation areas. These buildings will be two to three-stories in height.

Area C- This area will be developed with 95 units and 240 bedrooms on 13.54 acres. The proposed density utilizing DUEs was approved at 8 units per acre and the proposed units meets that allowance. This area will be developed with one building, approximately 65' tall, which is consistent with what was approved with the preliminary plan. This area is immediately adjacent to the State Road 37/Interstate 69 highway. There are proposed to be 12 one-bedroom units, 57 two-bedroom units, 41 three-bedroom units, and 3 four-bedroom units. There will be 50 parking spaces within the building for the 240 bedrooms, which equals 0.15 parking spaces per bedroom.

Area D- This area will be developed with 128 duplex units and 330 bedrooms on 11.13 acres. The proposed density utilizing DUEs was approved at 9.75 units per acre. There are proposed to be 26 one-bedroom units, 38 two-bedroom units, 12 three-bedroom units, and 36 four-bedroom units. These units will all front on a public street with on-street parking spaces along the front. The main parking areas have been designed to be located in the rear of the structures. There will be 161 on-site parking spaces for the 330 bedrooms which equals 0.48 parking spaces per bedroom, there will also be 137 on-street parking spaces in this phase. These buildings will be one and two-stories in height. A portion of this area has an intermittent stream and wetland that have been shown to be placed in a conservation easement. This area also has an electric line that runs along the east side of the area with a 100' wide easement.

SECONDARY PLAT:

Access: There are two proposed vehicular and pedestrian accesses roughly 335 feet apart on 17th Street that were approved with the final plan. The western access connects to 17th Street through an existing platted right-of-way, while the eastern access utilizes an access easement that will be dedicated as public right-of-way. There is an additional vehicular and pedestrian access proposed through an existing parcel to Arlington Road to the east of the site that would also be dedicated as right-of-way. Sidewalks are planned on the internal public and private rights-of-way and a multi-use path is included to connect the project to 17th Street.

Streetscape: The project is proposing that a majority of the internal streets be public. The internal proposed roads (both public and private) contain parallel, on-street parking and sidewalks. Due to the several environmental constraints on Parcel B, the Plan Commission approved a cross section with not requiring the tree plot along the parking spaces and to allow the tree plot behind the sidewalk. All public streets have a minimum 5' wide concrete sidewalk and minimum 5' wide tree plot with street trees not more than 40' from center. The petitioner will be following the Transportation Plan and Complete Streets design guidelines for the new internal public roads. All cross sections of the internal roads were reviewed and approved with the grading permit. The petitioner is currently working with the Engineering Department on improvements to the design of the Arlington Road access, as required in the grading permit.

Alternative Transportation: This petition would feature a 10' wide multi-use path that runs through the property and connects from Arlington Road all the way to 17th Street. There will also be internal sidewalks along all of the public and private streets.

Environmental Considerations: There are multiple environmental constraints on the site, including streams and steep slopes, and potential sinkholes and wetlands. These have all been shown to be placed in the required easements on the plat. All portions of the site that have intermittent streams present or wetlands are set aside in conservation easements.

Lot Arrangement: This petition involves the platting of 45 single family lots with one common area lot that will serve as a pocket park and four individual lots that will contain multi-family buildings. The single family lots were approved with R4 district standards that have a minimum lot size of 4,000 square feet and 35' wide. All of the proposed single family lots meet those requirements.

Facilities Maintenance Plan: A Facilities plan has been submitted with this petition. The Facilities Maintenance Plan meets the UDO requirements. The Facilities Plan was reviewed with the grading permit as well.

Right-of-way Dedication: The majority of the interior roads will be public and placed in dedicated right-of-way. The cross sections for these roads was approved with the final plan and include pedestrian facilities on both sides and tree plots with some modifications in Area B. Most of the internal roads feature on-street parking on both sides. There is only 50' of right-of-way shown for the streets with proposed on-street parking and this must be expanded to include the sidewalks within the right-of-way. This must be adjusted on the secondary plat.

General Compliance Criteria [20.06.040(d)(6)(B)]

i. Compliance with this UDO

The proposed use and development shall comply with all applicable standards in this UDO, unless the standard is lawfully modified or varied. Compliance with these standards is applied at the level of detail required for the subject submittal.

PROPOSED FINDINGS: The proposed site plat meets all of the requirements of the UDO. The secondary plat is identical to the approved primary plat that the Plan Commission approved.

ii. Compliance with Other Applicable Regulations

The proposed use and development shall comply with all other city regulations and with all applicable regulations, standards, requirements, or plans of the federal or state governments and other relevant entities with jurisdiction over the property or the current or proposed use of the property. This includes, but is not limited to, floodplain, water quality, erosion control, and wastewater regulations

PROPOSED FINDINGS: A grading permit and final plan approval have already been given and the site plan complies with all of the UDO standards. Permits from IDEM were secured with the grading permit.

iii. Compliance with Utility, Service, and Improvement Standards

1. As applicable, the proposed use and development shall comply with federal, state, county, service district, city, and other regulatory authority standards, and design/construction specifications for roads, access, drainage, water, sewer, schools, emergency/fire protection, and similar standards
2. Municipal sewer and water hookup are required for all developments except for instances where written approvals by the City Utilities Department and the County Health Department grant an exception to the hookup requirement. All sewer and water facilities shall meet the design specifications of the City Utilities Department
3. When public improvements are required, the petitioner or authorized representative shall post performance and maintenance guarantees for such improvements. Such financial guarantees shall be submitted, reviewed, and approved per 20.06.060(c)(3)(E)iii (Financial Bond Required).

PROPOSED FINDINGS: As mentioned previously, the utility and stormwater requirements were approved by the City of Bloomington Utility Department with the grading permit. Public improvements will be bonded for prior to signature of the plat. A public improvements bond will be submitted if needed for the sidewalk and street tree work in the rights-of-way.

iv. Compliance with Previous Approvals

The proposed use and development shall be consistent with the terms and conditions of any prior land use approval, plan, or plat approval for all or part of the property that is in effect and not proposed to be changed. This includes consistency with any approved phasing plan for development and installation of public improvements and amenities.

PROPOSED FINDINGS: As mentioned previously, the proposed secondary plat is identical to the primary plat. The final site plan was approved by the Plan Commission and in compliance with that approved plan, a grading permit has been issued to allow site work.

CONCLUSION: The petitioner has designed this secondary plat to align with the approved final plan and primary plat. This overall petition has attempted to be sensitive to the neighboring existing uses, while addressing diverse housing concerns, and providing public benefit.

RECOMMENDATION: The Department recommends that the Plat Committee adopt the proposed findings and approve the secondary plat with the following conditions:

1. Petitioner will work with the Planning and Transportation Department and the Engineering Department to finalize plans for the right-of-way connection to Arlington Road within the terms of the approved grading permit.
2. A public improvement bond must be approved and submitted to the Department prior to signature of the secondary plat.

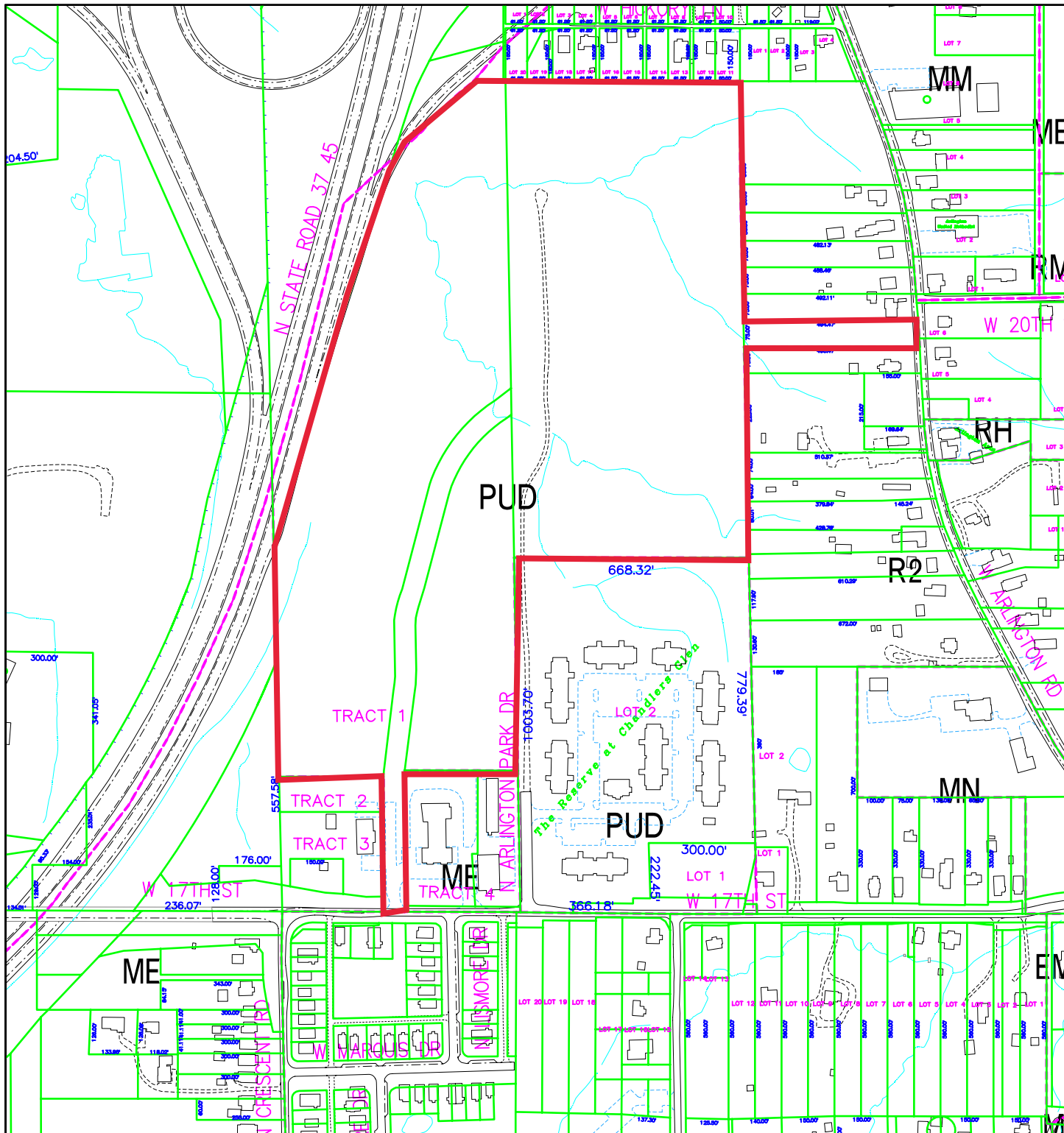

By: greulice
1 Dec 20

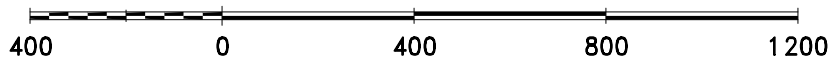

For reference only; map information NOT warranted.

City of Bloomington
Planning & Transportation



Scale: 1" = 400'

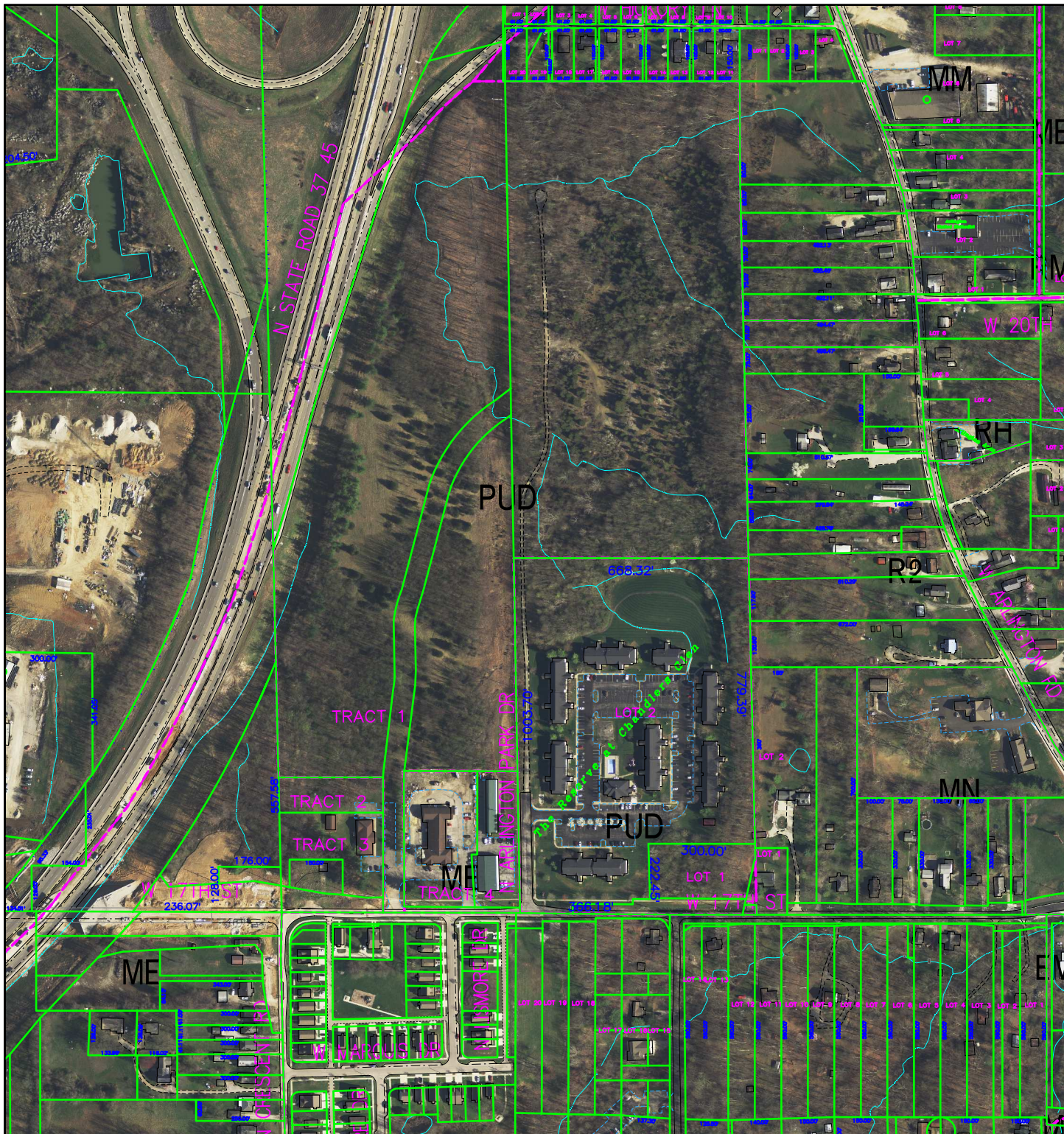

By: greulice
1 Dec 20

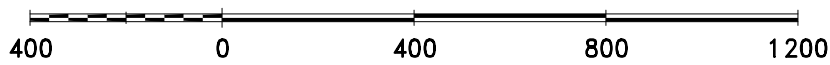

City of Bloomington
Planning & Transportation

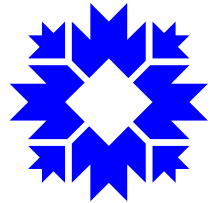

Scale: 1" = 400'

For reference only; map information NOT warranted.

**TRINITAS**[®]

Corporate HQ
201 Main Street, Suite 1000
Lafayette, IN 47901

www.trinitas.ventures
phone: (765) 807-2700

Indianapolis Office
6300 Cornell Avenue
Indianapolis, IN 46220

November 12, 2020

Eric Greulich
Senior Zoning Planner
City of Bloomington
401 N. Morton Street
Bloomington, IN 47404

RE: Trinitas Final Plat Submittal, "W. 17th Street."

Dear Mr. Greulich,

Trinitas Ventures is pleased to submit the enclosed Final Plat submittal for the subject project. The District Ordinance and Preliminary Plan for this development was approved by City Council as Ordinance 20-04 on March 5, 2020. The Preliminary Plat and Final Plan for this development was approved by Plan Commission as PUD 12-20 on June 8, 2020. Enclosed in this submittal are the revised Final Plat and Facilities Maintenance Plan for review. The final plat encompasses a total of 52 lots. These lots include 45 single family lots to be dedicated to the City of Bloomington, 6 lots for multifamily buildings, and 1 lot encompassing the conservation areas on site.

Thank you for your time and consideration of this final plat, and we look forward to continuing to work with Staff on this development. If you require any additional information at this time, please contact me at khansen@trinitas.ventures.

Sincerely,

Kimberly Hansen

cc: Daniel Butler
Jeff Fanyo
Jeffrey Kanable
Daniel Moriarity

- PROPERTY LINE -----
- EASEMENT LINE -----
- FENCE X-----X
- OVERHEAD UTILITIES -OHU-----
- OVERHEAD ELECTRIC LINE -E-----
- UNDERGROUND ELECTRIC LINE -UGE-----
- UNDERGROUND GAS LINE -GAS-----
- UNDERGROUND TELEPHONE LINE -UGT-----
- WATER LINE -W-----
- SANITARY SEWER LINE -S-----
- DEED RECORD BOOK AND PAGE XXX/XXX
- 5/8" REBAR WITH CAP SET ○ 5
- MAG NAIL SET ○ MN
- RECORD ○ R
- MEASURED ○ M
- RIGHT-OF-WAY ○ ROW
- UTILITY POLE ○
- FIRE HYDRANT ○
- ELECTRIC METER ○
- WATER METER ○
- TELEPHONE RISER ○
- ELECTRIC TRANSFORMER ○
- STORM BASIN ○
- WATER VALVE ○
- SIGN ○
- AREA LIGHT ○
- SANITARY SEWER CLEAN OUT ○
- CABLE T.V. BOX ○
- GAS METER ○
- LANDSCAPE AREA ○
- INGRESS AND EGRESS EASEMENT L.S.
- DRAINAGE AND UTILITY EASEMENT L. & E.
- UTILITY POLE ANCHOR ○
- ANTENNA ○
- MAIL BOX ○
- AIR CONDITIONING PAD AC
- GENERATOR ○
- L.P. GAS TANK ○
- HANDICAP PARKING SPACE ○

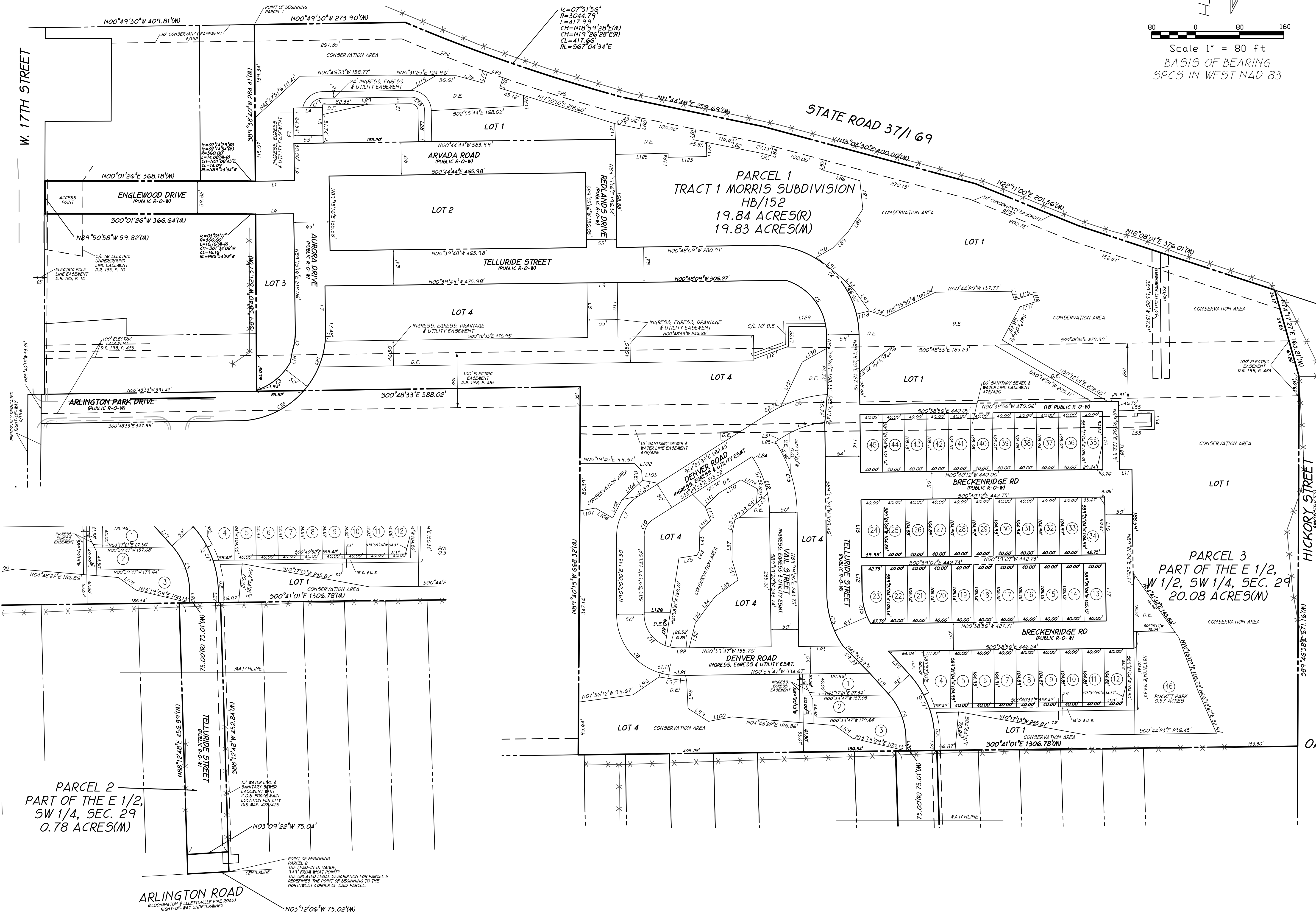
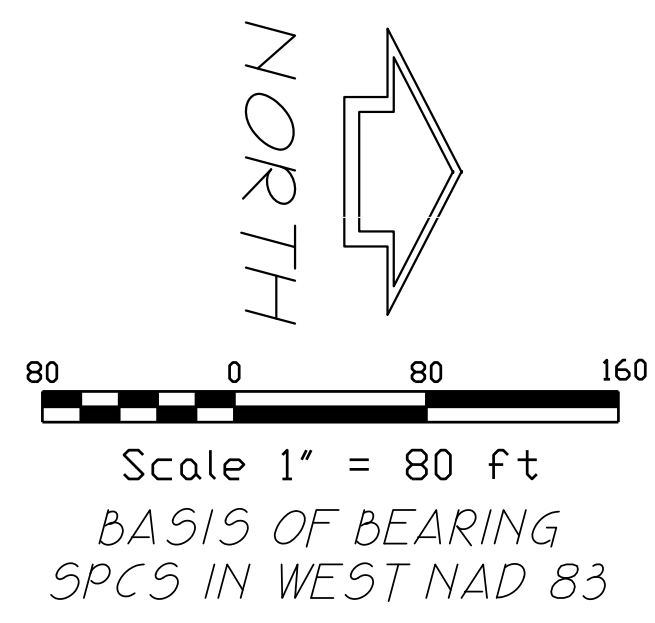

PARCEL 2
PART OF THE E 1/2,
SW 1/4, SEC. 29
0.78 ACRES(M)

PARCEL 3
PART OF THE E 1/2,
SW 1/4, SEC. 29
20.08 ACRES(M)

ARLINGTON ROAD
(BLOOMINGTON & GLETTVILLE PIKE ROAD)
RIGHT-OF-WAY UNDETERMINED

17TH & ARLINGTON
PRELIMINARY PLAT
W 17TH STREET,
ARLINGTON ROAD &
STATE ROAD 37

DRAWING NO. 401334
SHEET 1 OF 2

NUMBER	DELTA ANGLE	RADIUS	ARC LENGTH	CHORD DIRECTION	CHORD LENGTH
C1	17°33'55"	105.00	32.19	N80°30'52"W	32.06
C3	42°07'20"	110.00	80.87	S39°31'42"E	79.06
C4	87°36'09"	164.00	250.75	N45°31'16"E	227.03
C5	72°05'24"	105.00	132.11	S53°16'38"W	123.57
C6	28°15'15"	225.00	110.95	S17°39'32"E	109.83
C7	57°36'27"	85.00	85.46	S61°11'47"E	81.91
C8	90°00'02"	110.00	172.79	N44°59'59"E	155.56
C9	41°18'11"	125.00	90.11	N68°40'23"E	88.17
C10	57°36'03"	35.00	35.19	S61°11'35"E	33.72
C11	90°00'02"	60.00	94.25	N44°59'59"E	84.85
C12	30°53'14"	185.00	99.73	S73°52'43"W	98.53
C13	30°53'14"	235.00	126.68	S73°52'43"W	125.16
C14	25°37'21"	175.00	78.26	N18°47'53"W	77.61
C15	35°25'33"	166.00	102.64	N73°01'40"E	101.01
C16	29°27'04"	116.00	59.63	N74°35'49"E	58.97
C17	41°18'11"	177.00	127.59	N68°40'23"E	124.85
C18	90°00'00"	25.00	39.27	S44°15'16"W	35.36
C19	70°54'32"	25.00	30.94	S36°12'00"E	29.00
C21	41°44'24"	160.01	116.57	S69°49'32"E	114.01
C23	00°33'52"	3074.79	30.30	N19°25'21"E	30.30
C24	03°06'05"	3074.79	166.44	N21°15'20"E	166.42
C25	04°05'53"	3074.79	219.92	N17°05'28"E	219.87

SOURCE OF TITLE: INST. NO. 2019014929, D.R. 392, P. 63 & D.R. 199, P. 315

OWNERS: ROGERS MANAGEMET, INC., ROGERS GROUP INC & JAMES T. MORRIS REVOCABLE TRUST
 ZONING: PUD - PLANNED UNIT DEVELOPMENT, BP-BUSINESS PARK & RS-RESIDENTIAL SINGLE FAMILY

The undersigned, as owners of the real estate described on this plat, for and in consideration of the City of Bloomington, Indiana, granting to the undersigned the right to tap into and connect to the sewer system of the City of Bloomington for the purpose of providing sewer service to the described real estate, now release the right of the undersigned as owners of the platted real estate and their successors in title to remonstrate against any pending or future annexation by the City of Bloomington, Indiana, of such platted real estate.

_____, the owners of the real estate shown and described herein, does hereby lay off, plat, and subdivide said real estate in accordance with the within plat.

This subdivision shall be known and designated as _____, an addition to the City of Bloomington. All streets and alleys shown, and not heretofore dedicated are dedicated to the public.

Front and side yard building setback lines are established as shown on the plat, between which lines and the property lines of the adjacent streets no building or other structure shall be erected or maintained.

The strips of ground that are shown on the plat and marked "easement" are owned by the owners of the lots that they respectively affect, subject to the rights of public utilities for the installation and maintenance of water and sewer mains, poles, ducts, lines, and wires. Buildings or other structures shall not be erected or maintained on these strips.

This subdivision shall be subject to the Declaration Of Covenants, Conditions, and Restrictions as set forth in Instrument Number _____ in the Office of the Recorder of Monroe County, Indiana.

Signed and Sealed _____, 20____.

Signature _____ Office _____

Name Printed _____

STATE OF INDIANA)
) SS:
 COUNTY OF MONROE)

Before me, the undersigned Notary Public, in and for the said county and state, personally appeared _____, and acknowledged the execution of the foregoing for the purposes therein expressed.

Witness my hand and notarial seal this _____ day of _____, 20____.

County of Residence _____ Commission Expiration _____

Notary Public, Written _____ Notary Public, Printed _____



PROJECT LOCATION

LOCATION MAP

NUMBER	DIRECTION	DISTANCE
L1	N00°44'44"W	70.93'
L2	S89°16'54"W	37.64'
L3	S89°12'01"W	94.57'
L4	N00°47'50"W	53.00'
L5	N89°12'01"E	64.59'
L6	N00°44'44"W	69.34'
L7	N89°15'16"E	83.03'
L8	N89°15'16"E	99.26'
L9	N00°26'53"W	55.00'
L10	S89°15'16"W	98.92'
L11	N00°40'46"W	22.83'
L12	S89°20'29"W	48.11'
L13	S89°20'29"W	104.85'
L14	S89°19'20"W	105.16'
L15	N89°20'53"E	105.00'
L16	N89°19'20"E	104.99'
L17	N89°21'04"E	105.16'
L18	S79°34'14"E	21.46'
L19	N48°01'18"E	50.38'
L20	N89°19'29"E	21.40'
L21	N00°00'02"W	15.22'
L22	N00°00'02"W	14.93'
L23	N00°39'47"W	80.67'
L24	S58°26'07"W	8.22'
L25	S58°26'07"W	8.95'
L26	N48°01'18"E	57.82'
L27	N89°19'29"E	21.39'
L28	S89°15'16"W	56.39'
L29	S00°44'44"E	160.25'
L31	S32°23'33"E	19.39'
L76	N15°08'03"E	51.92'
L77	N72°33'45"W	20.90'
L78	S71°48'47"E	19.72'
L79	N11°30'25"E	46.56'
L80	N78°15'11"W	19.58'
L81	S78°15'11"E	19.40'
L82	N11°31'39"E	126.54'
L83	N15°30'02"E	16.19'
L84	N74°56'30"W	17.70'
L85	S74°56'30"E	18.47'
L86	N15°45'41"E	68.32'
L87	N84°01'21"E	51.79'
L88	S57°02'05"E	50.85'
L89	S45°59'07"E	39.40'
L90	S29°46'33"E	33.62'
L91	N39°00'13"E	59.67'
L92	N45°15'59"E	33.34'
L93	N54°10'59"E	44.56'
L94	N17°42'59"E	31.85'
L96	N34°20'58"W	57.39'
L97	N08°24'02"E	50.78'
L98	N87°11'42"E	49.78'
L99	N32°15'44"E	43.86'
L100	N10°39'35"W	43.96'
L101	N35°27'18"E	39.59'
L102	N46°21'01"E	17.90'
L103	N85°41'20"E	17.51'
L104	S43°21'00"E	50.69'
L105	S63°00'26"E	37.46'
L106	S29°44'55"W	36.18'
L107	S10°14'59"E	29.03'
L108	N85°52'47"W	25.95'
L109	S28°49'23"W	34.17'
L110	S31°17'10"E	47.65'
L111	S44°59'24"E	34.28'
L112	N68°23'36"E	26.64'
L113	S46°23'35"E	30.02'
L114	N70°28'26"E	16.70'
L115	N18°00'55"W	34.79'
L116	N71°59'05"E	15.00'
L117	S18°00'55"E	28.86'
L118	N13°41'59"W	23.99'
L119	N30°21'59"W	53.72'
L120	N88°44'11"E	19.01'
L121	S87°16'18"W	28.46'
L122	N88°44'11"E	25.66'
L123	S01°15'49"E	70.06'
L124	S88°44'11"W	7.46'
L125	S01°15'49"E	95.34'
L126	N00°14'57"W	47.51'
L127	N20°01'10"W	61.62'
L128	N89°12'22"W	37.56'
L129	N00°10'10"W	71.47'
L130	S29°11'25"E	50.64'
L131	S64°04'08"E	90.47'

LEGAL DESCRIPTION

Updated Parcel 1:
 Tract 1 in Morris Subdivision, as per plat thereof, recorded in Plat Book 115, in the Office of the Recorder of Monroe County, Indiana, recorded May 12, 1999, more particularly described as follows:
 A part of the Southwest Quarter of Section 29, Township 9 North, Range 1 West, Monroe County, Indiana being more particularly described as follows: commencing at the Southwest corner of the aforesaid Quarter section; thence on the West line of said Quarter section North 00 degrees 49 minutes 30 seconds West 409.81 feet to the point of beginning;
 Thence continuing North 00 degrees 49 minutes 30 seconds West 273.90 feet to a point on the Easterly right-of-way of State Road No. 37 and the beginning on a non-tangent curve concave northwesterly having a radius of 3044.79 feet to which a radial line bears South 67 degrees 04 minutes 34 seconds East; thence on said curve and right-of-way Northeastly 417.99 feet through a central angle of 07 degrees 51 minutes 56 seconds; thence North 11 degrees 44 minutes 44 seconds East 201.56 feet; thence North 15 degrees 03 minutes 30 seconds East 400.00 feet; thence North 18 degrees 08 minutes 01 seconds East 376.01 feet; thence leaving said right-of-way North 74 degrees 17 minutes 27 seconds East 163.21 feet; thence South 00 degrees 48 minutes 33 seconds East 1893.54 feet; thence South 89 degree 38 minutes 40 seconds West 321.37 feet to the beginning of a curve concave southeasterly having a radius of 300.00 feet to which a radial line North 86 degrees 53 minutes 22 seconds West; thence on said curve Southerly 16.16 feet through a central angle of 03 degrees 05 minutes 11 seconds; thence South 00 degrees 01 minutes 26 seconds West 366.64 feet; thence North 89 degrees 50 minutes 58 seconds West 59.82 feet thence North 00 degrees 01 minutes 26 seconds West 368.18 feet to the beginning of a curve concave southeasterly having a radius of 360.00 to which a radial line bears North 89 degrees 53 minutes 34 seconds West; thence on said curve Northwesterly 14.08 feet through a central angle of 02 degrees 14 minutes 34 seconds; thence North 89 degrees 38 minutes 40 seconds East 284.41 feet to the point of beginning, containing 19.83 acres, more or less.

Updated Parcel 2:
 A part of the East half of the Southwest Quarter of Section 29, Township 9 North, Range 1 West, Monroe County, Indiana being more particularly described as follows:
 Commencing at the Southwest corner of the aforesaid Quarter section; thence on the West line of said Quarter section North 00 degrees 49 minutes 30 seconds West 409.81 feet; thence continuing North 00 degrees 49 minutes 30 seconds West 273.90 feet to a point on the Easterly right-of-way of State Road No. 37 and the beginning on a non-tangent curve concave northwesterly having a radius of 3044.79 feet to which a radial line bears South 67 degrees 04 minutes 34 seconds East; thence on said curve and right-of-way Northeastly 417.99 feet through a central angle of 07 degrees 51 minutes 56 seconds; thence North 11 degrees 44 minutes 44 seconds East 201.56 feet; thence North 15 degrees 03 minutes 30 seconds East 400.00 feet; thence North 22 degrees 11 minutes 00 seconds East 201.56 feet; thence North 18 degrees 08 minutes 01 seconds East 376.01 feet; thence leaving said right-of-way North 74 degrees 17 minutes 27 seconds East 163.21 feet to the southwest corner of the plat of Chanderville as shown by the plat recorded in Plat Cabinet B, Envelope 23 in the office of the Recorder of Monroe County, Indiana; thence on and along the south line of said plat South 89 degrees 46 minutes 58 seconds East 671.16 feet; thence leaving said south line South 00 degrees 41 minutes 01 second East 655.22 feet and the Point of beginning;
 Thence continuing South 00 degrees 41 minutes 01 second East 75.01; thence North 88 degrees 12 minutes 48 seconds East 456.89 to the west right-of-way line of Arlington Road; thence on said right-of-way line North 03 degrees 09 minutes 22 seconds West 75.04 feet; thence leaving said right-of-way South 88 degrees 12 minutes 48 seconds West 452.84 feet to the point of beginning, containing within said bounds 0.78 acres, more or less.

Updated Parcel 3:
 A part of the East half of the west half of the Southwest Quarter of Section 29, Township 9 North, Range 1 West, Monroe County, Indiana being more particularly described as follows:
 Commencing at the Southwest corner of the aforesaid Quarter section; thence on the West line of said Quarter section North 00 degrees 49 minutes 30 seconds West 409.81 feet; thence continuing North 00 degrees 49 minutes 30 seconds West 273.90 feet to a point on the Easterly right-of-way of State Road No. 37 and the beginning on a non-tangent curve concave northwesterly having a radius of 3044.79 feet to which a radial line bears South 67 degrees 04 minutes 34 seconds East; thence on said curve and right-of-way Northeastly 417.99 feet through a central angle of 07 degrees 51 minutes 56 seconds; thence North 11 degrees 44 minutes 44 seconds East 201.56 feet; thence North 15 degrees 03 minutes 30 seconds East 400.00 feet; thence North 22 degrees 11 minutes 00 seconds East 201.56 feet; thence North 18 degrees 08 minutes 01 seconds East 376.01 feet; thence leaving said right-of-way North 74 degrees 17 minutes 27 seconds East 163.21 feet to the southwest corner of the plat of Chanderville as shown by the plat recorded in Plat Cabinet B, Envelope 23 in the office of the Recorder of Monroe County, Indiana and the Point of beginning;
 Thence on and along the south line of said plat South 89 degrees 46 minutes 58 seconds East 671.16 feet; thence leaving said south line South 00 degrees 41 minutes 01 second East 1306.78 feet to the north line of Lot 2 Arlington Park Phase 1 as shown by the plat recorded in Plat Cabinet C, Envelope 96, in said office of the Recorder; thence on and along said north line North 89 degrees 40 minutes 15 seconds West 668.32 feet; thence leaving said north line North 00 degrees 48 minutes 33 seconds West 1305.52 feet to the point of beginning, containing within said bounds 20.08 acres, more or less.

Easements to be vacated per this plat:
 1. 60' Roadway and Utility Easement recorded in HB 152 in the office of the Recorder of Monroe County, IN, as granted in that certain Warranty Deed from James T. Morris and Donetta S. Morris, husband and wife, to James T. Morris, as Trustee under the James T. Morris Revocable Trust Agreement dated October 25, 1999, an undivided 50% interest and Donetta S. Morris, as Trustee under the Donetta S. Morris Revocable Trust Agreement dated October 25, 1999 an undivided 50%, dated February 11, 2000 and recorded February 15, 2000 as Document No. 2000002353.
 2. 15' Waterline and Sanitary Sewer Easement record in Deed book 478, Page 426 in the office of the Recorder of Monroe County, IN.

These easements are being vacated at the request of the property owners and with consent and approval of City of Bloomington Utilities.

I affirm under penalties of perjury, that I have taken reasonable care to redact each social security number in this document, unless required by law.
 Charles D. Graham
 This instrument prepared by Charles D. Graham

According to Flood Insurance Rate Map (FIRM) Community-Panel Number: 18105C 0141D, Map Revised: December 17, 2010 subject Property is not located in a floodplain.
 Source: FEMA

EASEMENT LEGEND
 UE = Utility Easement
 (A) Shall allow both private and public utility providers access associated with the installation, maintenance, repair, or removal of utility facilities.
 (B) Prohibits the placement of any unauthorized obstructions within the easement area.
 DE = Drainage Easement
 (A) Shall be required for any surface swales or other minor improvements that are intended for maintenance by the lots on which they are located.
 (B) Shall prohibit any alteration within the easement that would hinder or redirect flow.
 (C) Shall provide that the owner of the lot on which the easement is placed shall be responsible for maintenance of the drainage features within such easement.
 (D) Shall be enforceable by the City Utilities Department and by owners of properties that are adversely affected by conditions within the easement.
 (E) Shall allow the City Utilities Department to enter upon the easement for the purpose of maintenance, to charge the cost of such maintenance to the responsible parties, to construct drainage facilities within the easement, and to assume responsibility for the drainage features at its discretion.
 P55E = Private Sanitary Sewer Easement
 (A) Shall allow the Property owner or their assigns exclusive access for installation, maintenance, repair, or removal of sanitary sewer facilities.
 (B) Trees and structures including, but not limited to, buildings, fences, retaining walls, signs, and light fixtures, shall not be located within the Sanitary Sewer Easement.
 (C) Grading activity shall be prohibited within Sanitary Sewer Easements without written permission from the Property owner.
 W.L.E. = Waterline Easement.
 (A) Shall allow the city utilities department exclusive access for installation, maintenance, repair, or removal of potable water facilities.
 (B) Encroachment by other utilities is prohibited, unless such encroachment is approved by the city utilities department in conjunction with the preliminary plat. Upon written permission from the city utilities department, encroachments may be permitted after the recording of the final plat.
 (C) Trees and structures including, but not limited to, buildings, fences, retaining walls, signs, and light fixtures, shall not be located within waterline easements.
 (D) Grading activity shall be prohibited within waterline easements without written permission from the city utilities department.
 (E) Signs shall not be located within waterline easements unless the sign is a public sign authorized by Section 20.05.079(01) or is further authorized by the city.

CERTIFICATE OF APPROVAL OF PLANNING AND TRANSPORTATION

Under the authority of Indiana code 36-7-4 700 series, enacted by the General Assembly of the State of Indiana and Ordinance adopted by the Common Council of the City of Bloomington, Indiana, this plat was given approval by the City of Bloomington, as follows:

Approved by the City Planning and Transportation at a meeting held _____, 20____.

(Scott Robinson, Director of Planning and Transportation)

I certify that I am a Registered Land Surveyor licensed under the laws of Indiana; that this plat accurately represents a survey made by me on October 22, 2020 _____ and that the monuments shown on it exist; and that their locations, sizes, types, and materials are accurately shown.

Charles D. Graham
 Indiana L.S. 29500014
 Bynum Fanyo & Associates, Inc.
 528 North Walnut Street
 Bloomington, Indiana 47404-3804
 812-332-8030



17TH & ARLINGTON PRELIMINARY PLAT W 17TH STREET, ARLINGTON ROAD & STATE ROAD 37

DRAWING NO. 5118008 SHEET 2 OF 2



ARCHITECTURE
CIVIL ENGINEERING
PLANNING

BYNUM FANTO & ASSOCIATES, INC.
528 north walnut street
Bloomington, Indiana
(812) 332-8030

PROJECT:
**WEST 17TH STREET
PLANNED UNIT
DEVELOPMENT**
BLOOMINGTON, INDIANA

SCOPE DRAWINGS:
These drawings indicate the general scope of the project as well as architectural design, structural, mechanical, electrical and plumbing systems. The drawings do not necessarily indicate the details of work required for full performance and completion of the requirements of the contract. The contractor shall verify all items required for the proper installation and completion of the work.

REVISIONS:

NO.	DATE	DESCRIPTION

ISSUE DATE	DRAWN BY	CHECKED BY
09/22/2020	DJB	JSF

DRAWING TITLE:
**OVERALL
PROPOSED SITE
PLAN**

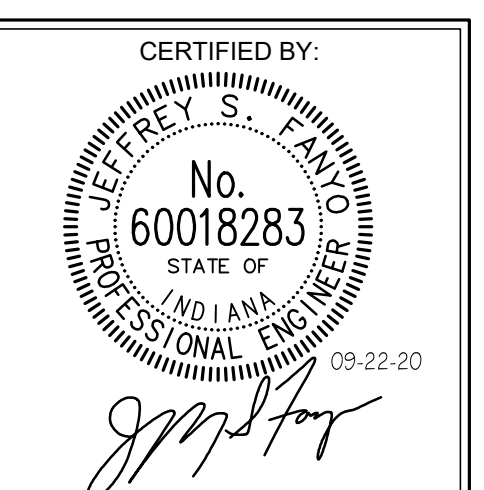

DRAWING NUMBER
C301

PROJECT NUMBER
401334

SITE INFORMATION

PROPOSED NUMBER OF *SITE* PARKING SPACES: 379 + 9 ADA = 388 TOTAL
TOTAL LOT AREA = 39.29 ACRES
PROPOSED IMPERVIOUS AREA: 15.73 ACRES
PROPOSED IMPERVIOUS COVERAGE %: 40.0%

EXISTING LEGEND

EXISTING FENCE	---
EXISTING WATER LINE	— W —
EXISTING OVERHEAD UTILITY LINES	— OHU —
EXISTING UNDERGROUND ELECTRIC LINES	— USE —
EXISTING UNDERGROUND TELEPHONE LINES	— UGT —
EXISTING UNDERGROUND FIBER OPTIC LINES	— FO —
EXISTING GAS LINE	— GAS —
EXISTING SANITARY FORCEMAIN	— FM —
EXISTING ELEVATION CONTOUR LINE	--- XXX ---
EXISTING SANITARY SEWER AND MANHOLE	— S —
EXISTING STORM SEWER AND INLET	— SI —
PROPERTY LINE	---
GEOTECHNICAL REPORT BORE HOLE LOCATION - SEE SEPARATE GEOTECHNICAL REPORT BY "PSI" FOR MORE INFORMATION	○ GEOTECHNICAL BORING KEY GROUND ELEV.=XXX ROCK ELEV.=XXX

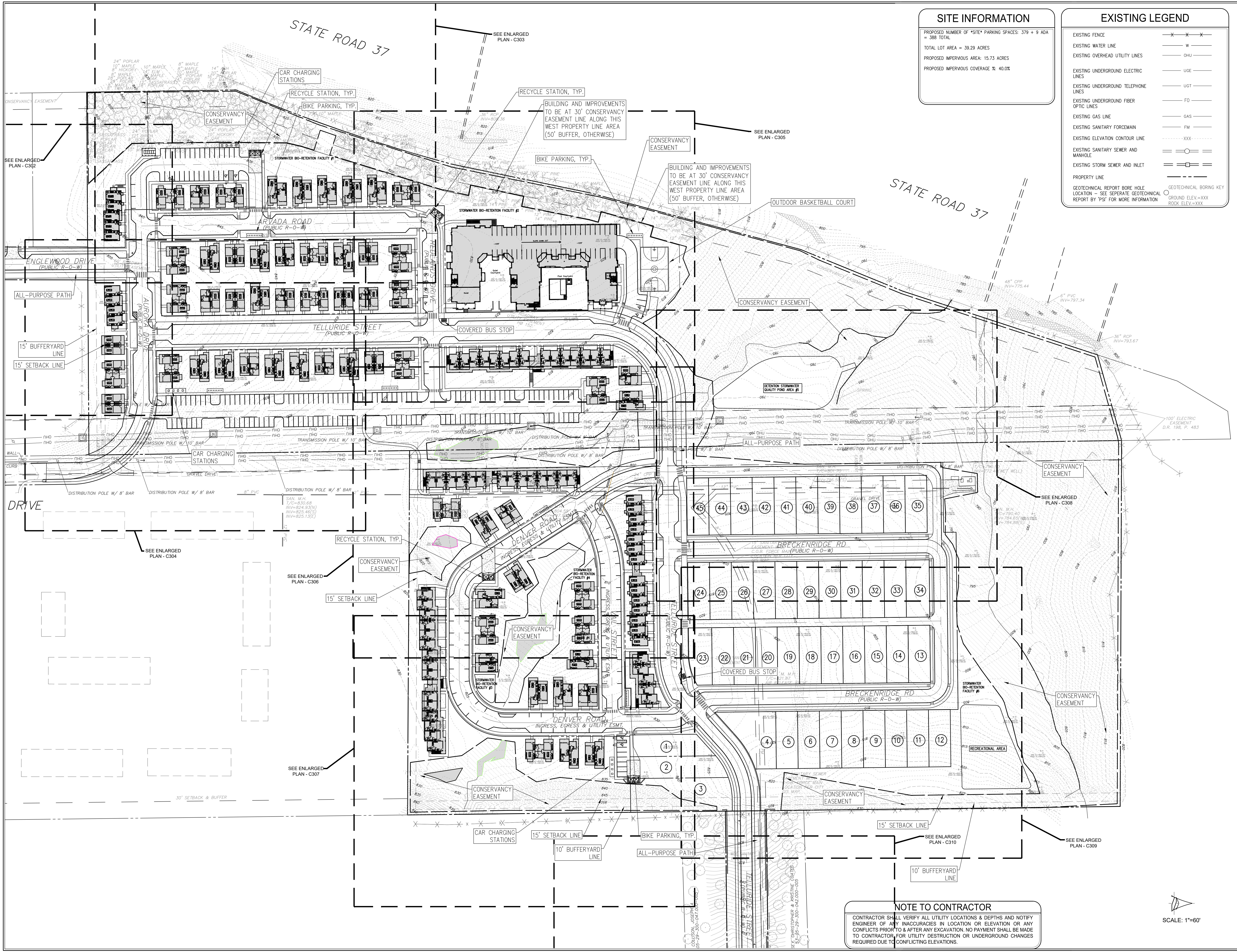

NOTE TO CONTRACTOR

CONTRACTOR SHALL VERIFY ALL UTILITY LOCATIONS & DEPTHS AND NOTIFY ENGINEER OF ANY INACCURACIES IN LOCATION OR ELEVATION OR ANY CONFLICTS PRIOR TO & AFTER ANY EXCAVATION. NO PAYMENT SHALL BE MADE TO CONTRACTOR FOR UTILITY DESTRUCTION OR UNDERGROUND CHANGES REQUIRED DUE TO CONFLICTING ELEVATIONS.

SCALE: 1"=60'



ARCHITECTURE
CIVIL ENGINEERING
PLANNING
BYNUM FANTO & ASSOCIATES, INC.
528 north walnut street
Bloomington, Indiana
(812) 339-2996 (Fax)
(812) 332-8030

PROJECT:
**WEST 17TH STREET
PLANNED UNIT
DEVELOPMENT**
BLOOMINGTON, INDIANA

SCOPE DRAWINGS:
These drawings indicate the general scope of the project in terms of structural design, materials, the dimensions of structures, mechanical and electrical systems, etc. They are not intended to be used for construction or to describe all work required for full performance and completion of the project. The contractor shall verify all items required for the proper design and construction of the work.

REVISIONS:
CCD 03 - COB AND IDEM COMMENTS - SHIFT CURB ONE FOOT WITHIN ON-STREET PARKING AREAS 12-23-20 DJB

ISSUE DATE	DRAWN BY	CHECKED BY
09/22/2020	DJB	JSF

DRAWING TITLE:
TYPICAL ROAD CROSS-SECTIONS & DETAILS

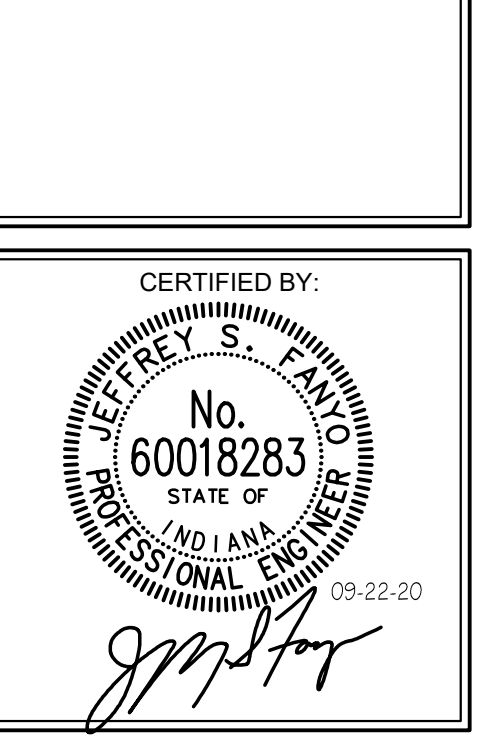

DRAWING NUMBER
C801

PROJECT NUMBER
401334

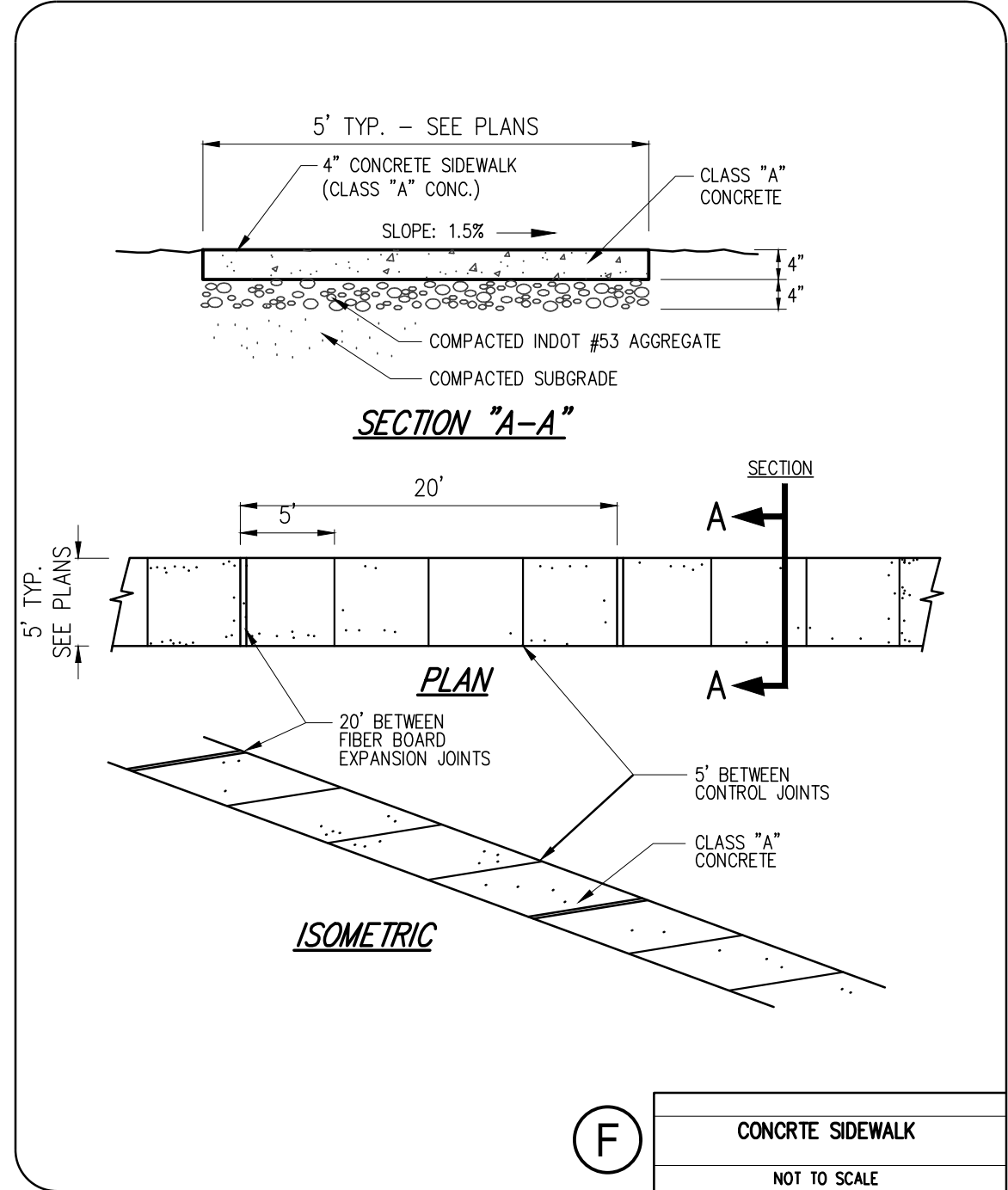
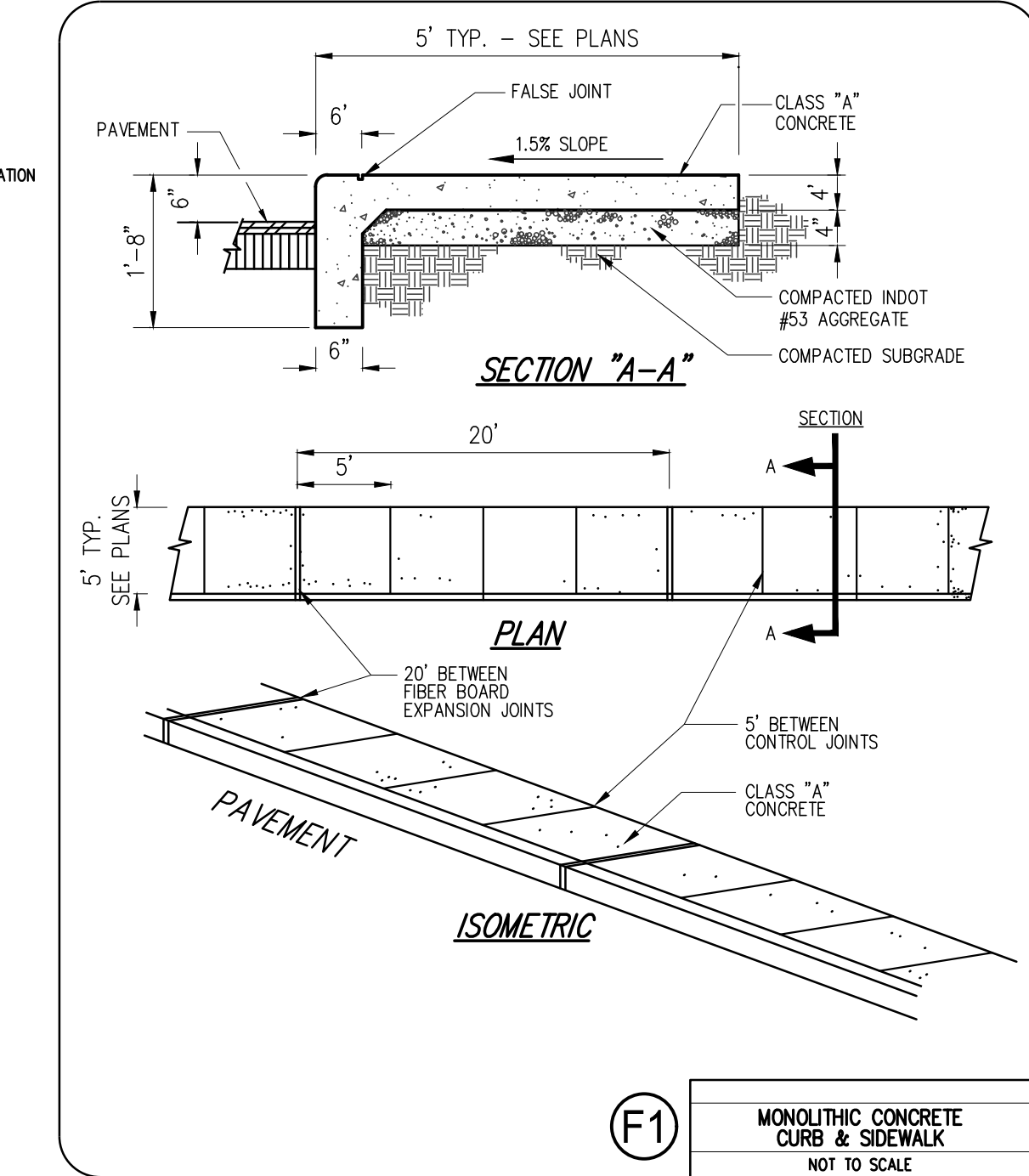
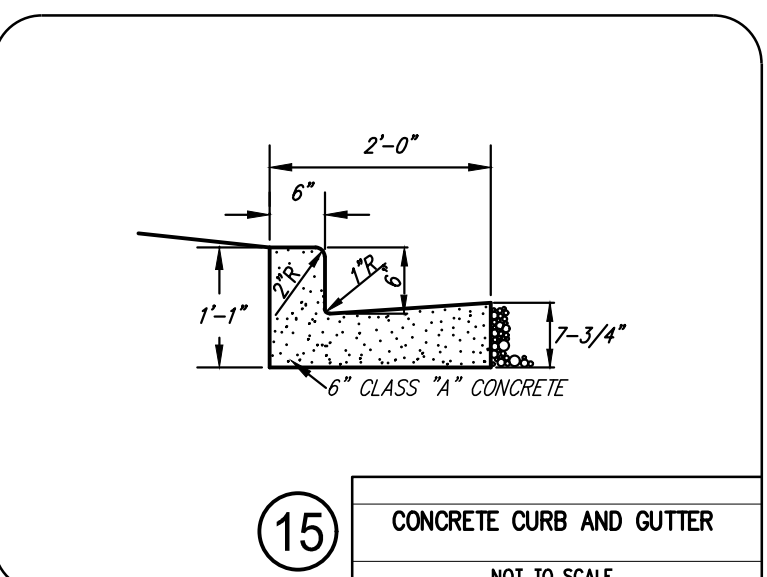
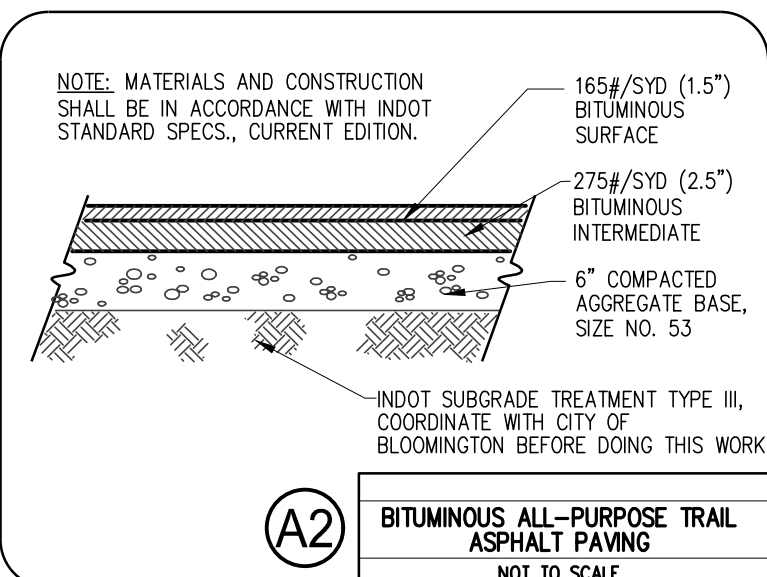
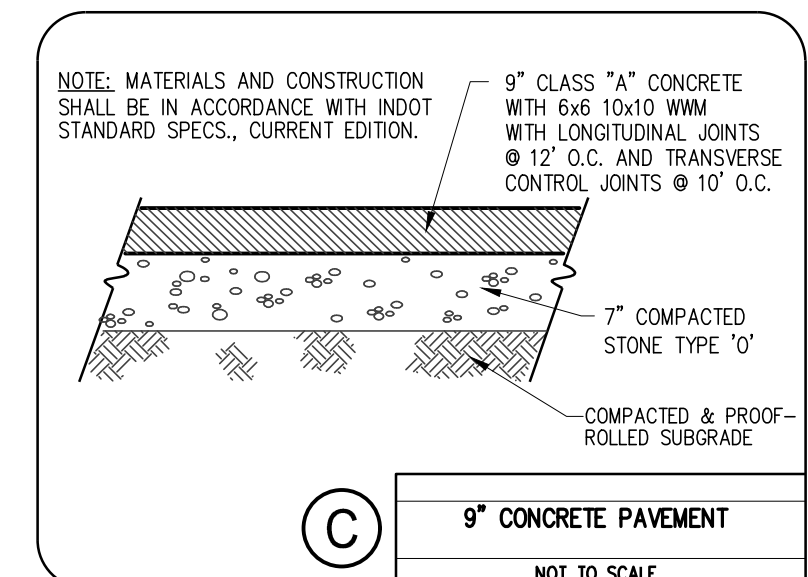
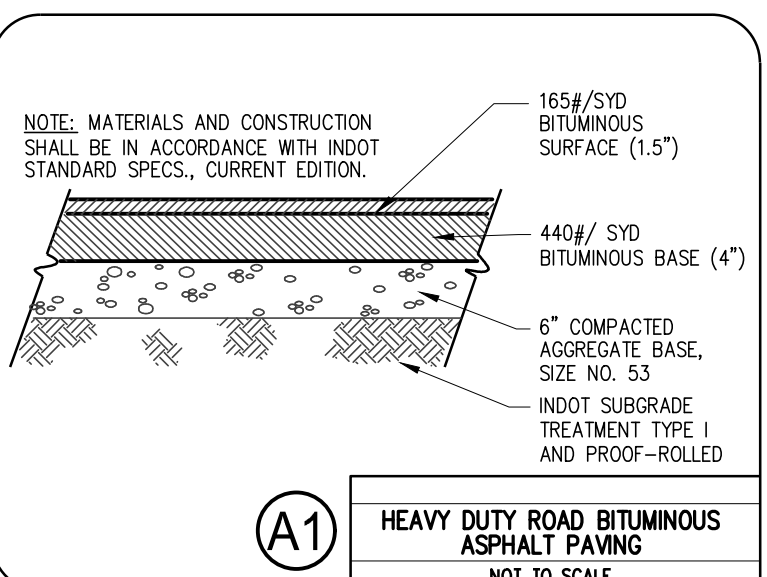
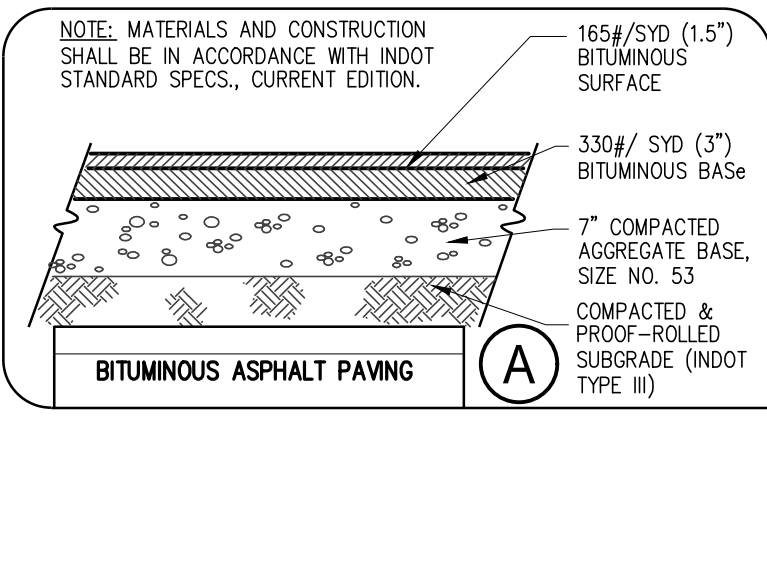
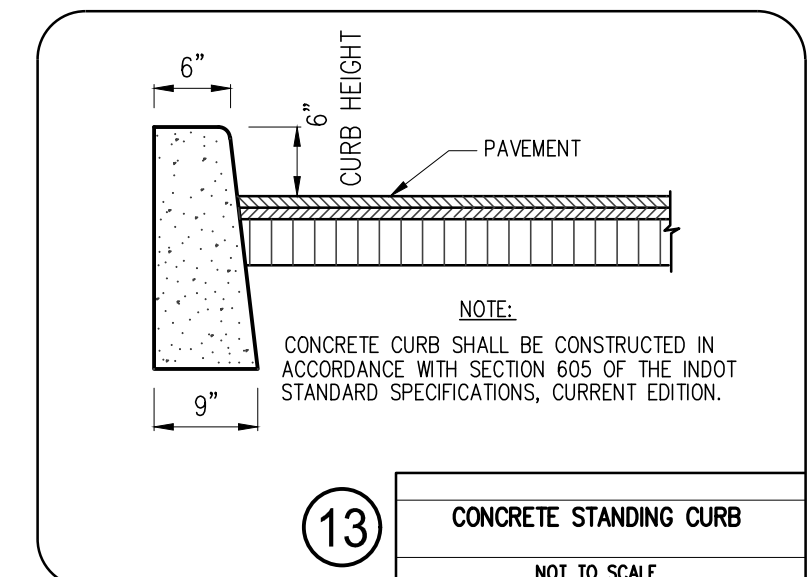

ALL WORK WITHIN EXISTING AND PROPOSED RIGHT-OF-WAY MUST BE CONDUCTED IN ACCORDANCE WITH CITY STANDARDS AND SPECIFICATIONS. THE CONTRACTOR SHALL BE RESPONSIBLE TO COORDINATE WITH THE CITY ALL REQUIRED INSPECTIONS AND TESTS. ALL REQUIRED TESTS SHALL BE PROVIDED AND PAID FOR BY THE CONTRACTOR

THE CURRENT EDITION OF THE PROPOSED ACCESSIBILITY GUIDELINES FOR PEDESTRIAN FACILITIES IN THE PUBLIC RIGHT-OF-WAY (PROWAG) TO BE USED WITH THESE PLANS FOR ALL RAMPS, SIDEWALKS, AND OTHER PEDESTRIAN FACILITIES. NO SLOPE OF ANY SECTION OF STREET, RAMPS, SIDEWALKS, AND OTHER WALKABLE FACILITIES SHALL BE MORE THAN 8.33% SLOPE LONGITUDINALLY (2% CROSS-SLOPE MAX. FOR STOP CONTROLLED, 5% CROSS-SLOPE MAX. FOR NON-STOP CONTROLLED) CONTRACTOR WILL BE ASKED TO REMOVE AND REPLACED IF ANY ARE CONSTRUCTED WITH A SLOPE GREATER THAN 8.33% LONGITUDINALLY OR 2% CROSS-SLOPE FOR STOP CONTROLLED, 5% CROSS-SLOPE MAX. FOR NON-STOP CONTROLLED. COORDINATE WITH ENGINEER BEFORE ANY AREA IS CONSTRUCTED IF ANTICIPATED TO BE IN VIOLATION OF THIS POLICY.

THESE TYPICAL CROSS-SECTIONS SHOWN ON THIS SHEET ARE FOR REFERENCE FOR GENERAL WIDTH AND SLOPING PATTERNS. FINAL GRADING SHALL BE FOLLOWED ON ENLARGED SITE SHEETS AND PLAN AND PROFILE SHEETS OF THIS PLAN SET.

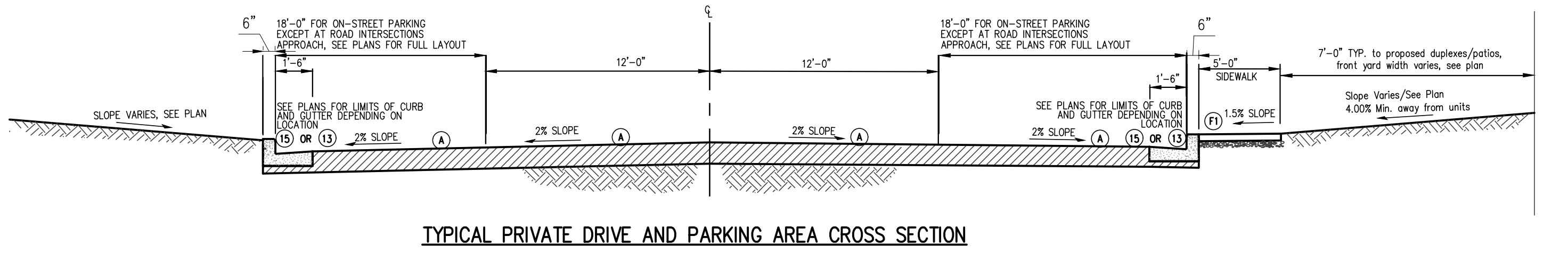
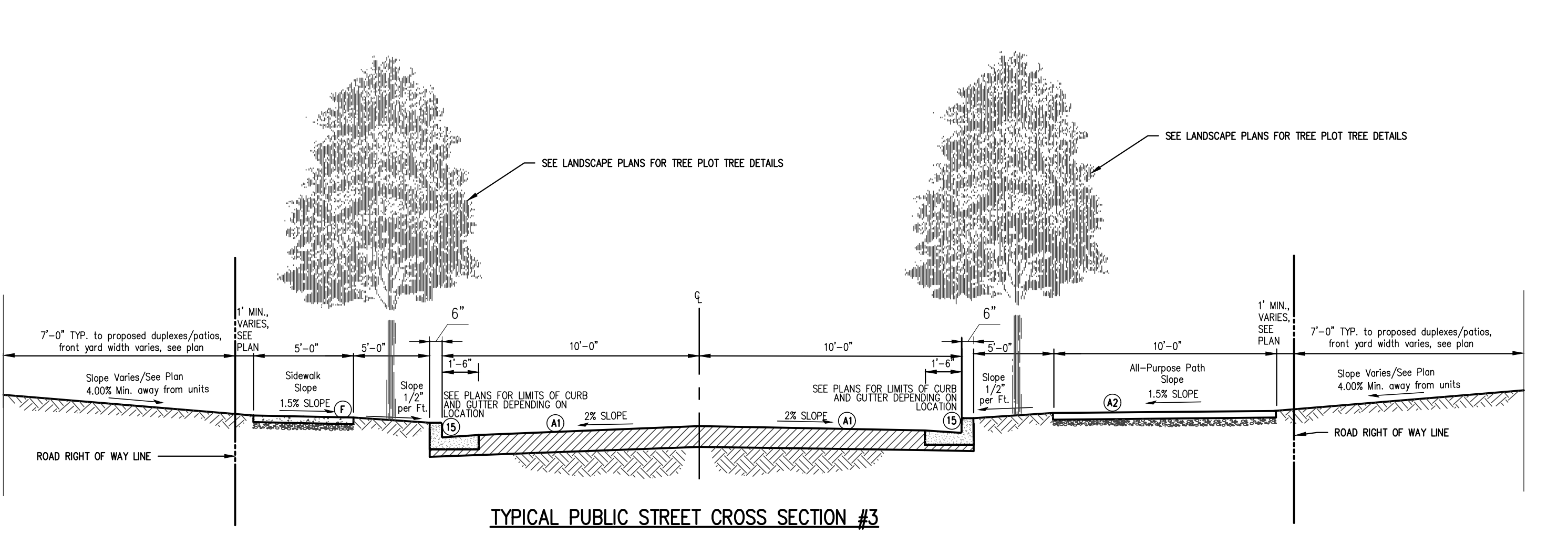
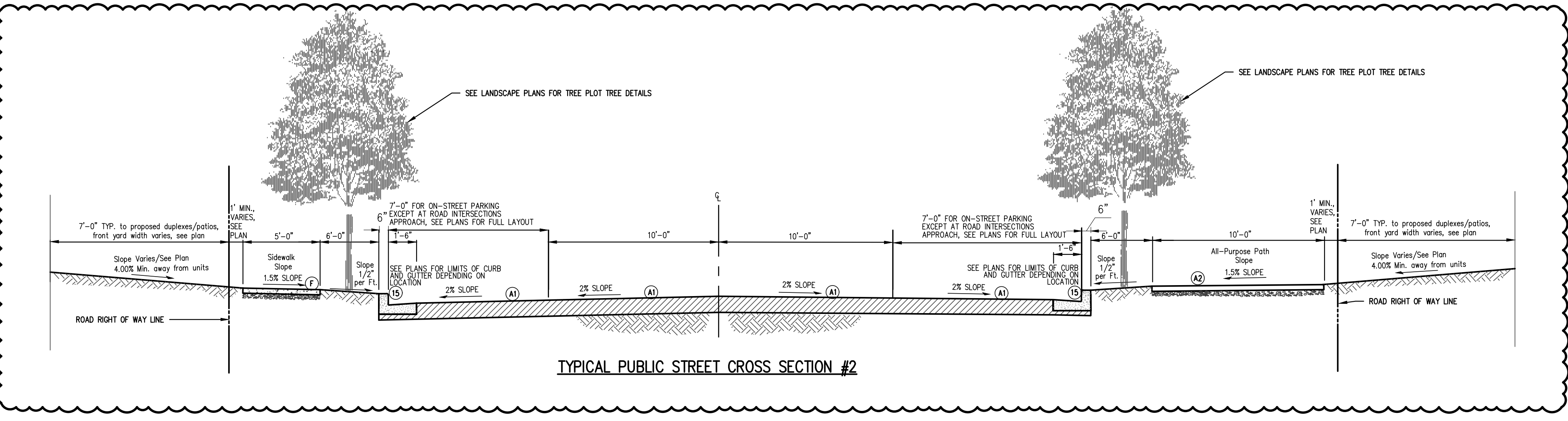
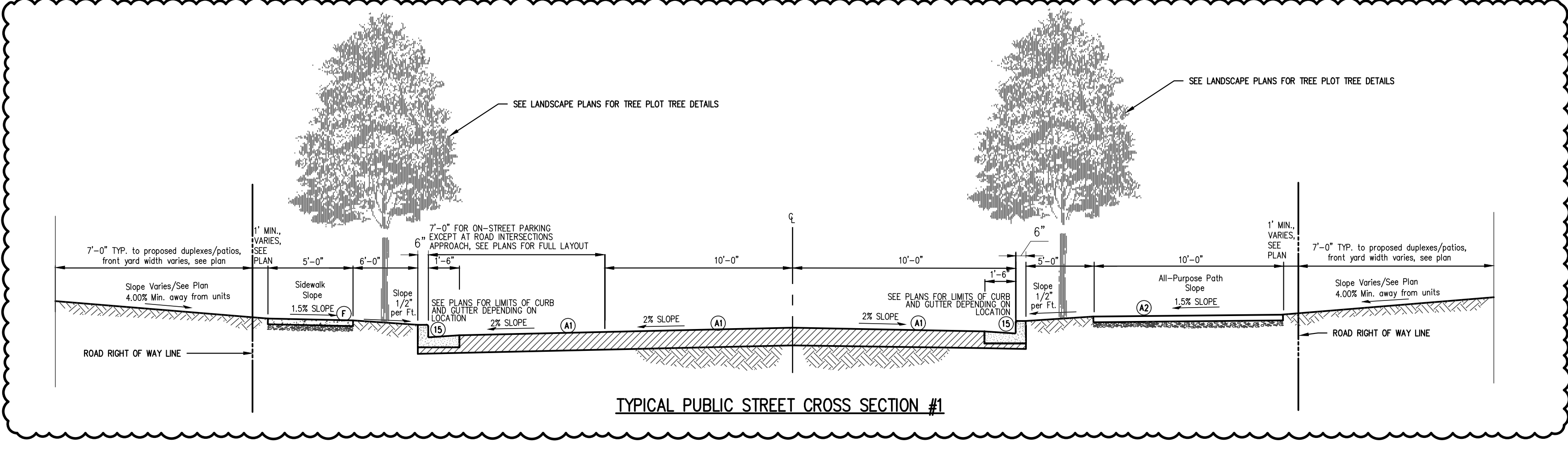
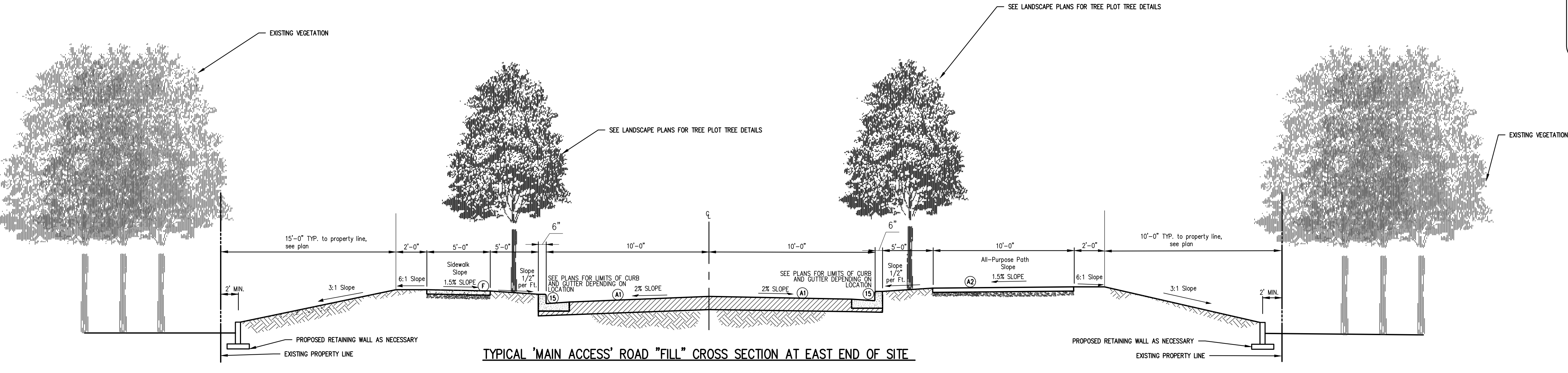
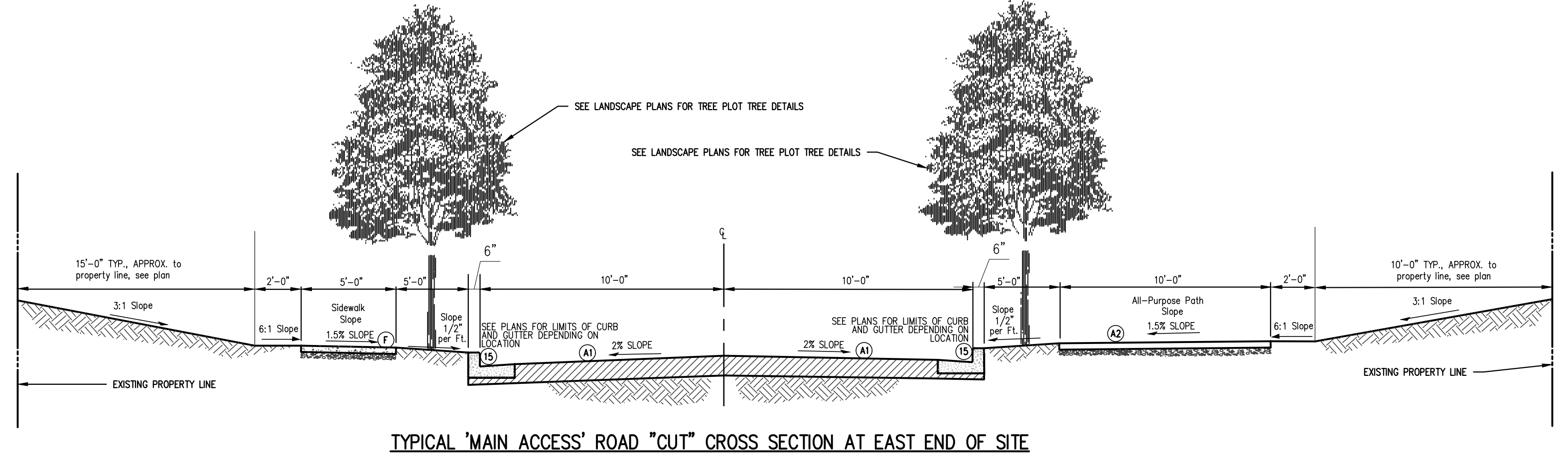
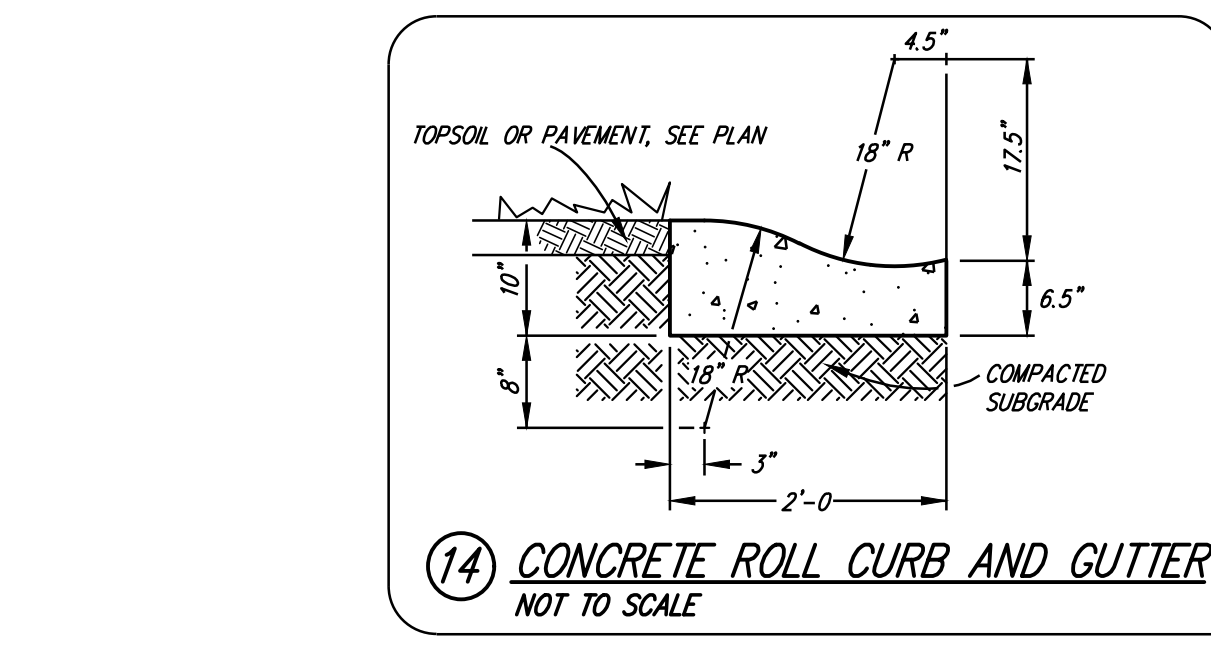
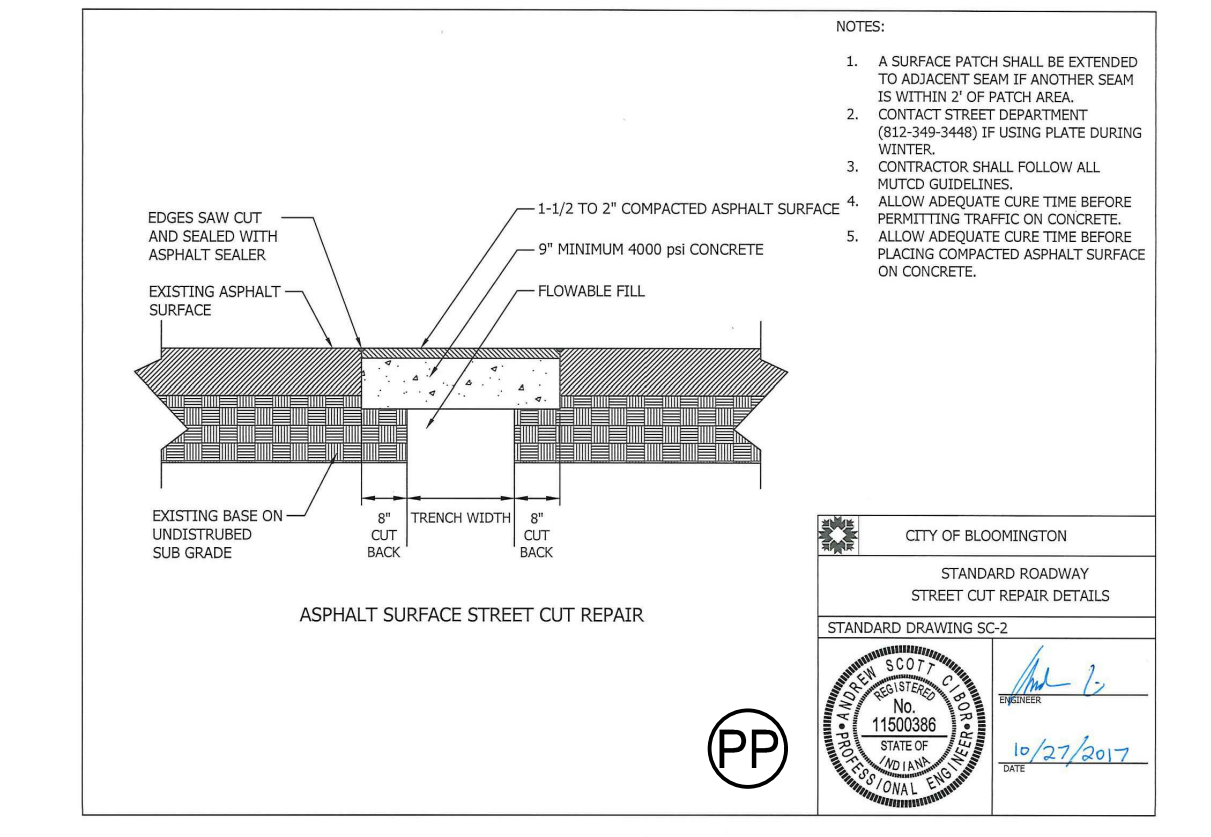



ARCHITECTURE
CIVIL ENGINEERING
PLANNING

BYNUM FANTO &
ASSOCIATES, INC.

528 north walnut street
Bloomington, Indiana
(812) 332-8030

PROJECT:
**WEST 17TH STREET
PLANNED UNIT
DEVELOPMENT**
BLOOMINGTON, INDIANA

SCOPE DRAWINGS:
These drawings indicate the general scope of the project as shown on architectural drawings, contracts, the determination of structural, mechanical and electrical systems, and form the basis for the design of the project. The drawings do not necessarily include all details and work required for full performance and completion of the requirements of the contract.
To the extent of the original design, including all revisions, the single contractor shall furnish all items required for the proper installation and completion of the work.

REVISIONS:

NO.	DATE	DESCRIPTION

ISSUE DATE	DRAWN BY	CHECKED BY
09/22/2020	DJB	JSF

DRAWING TITLE:
**'MAIN ACCESS'
ROAD'
CROSS-SECTIONS**



DRAWING NUMBER
C805

PROJECT NUMBER
401334

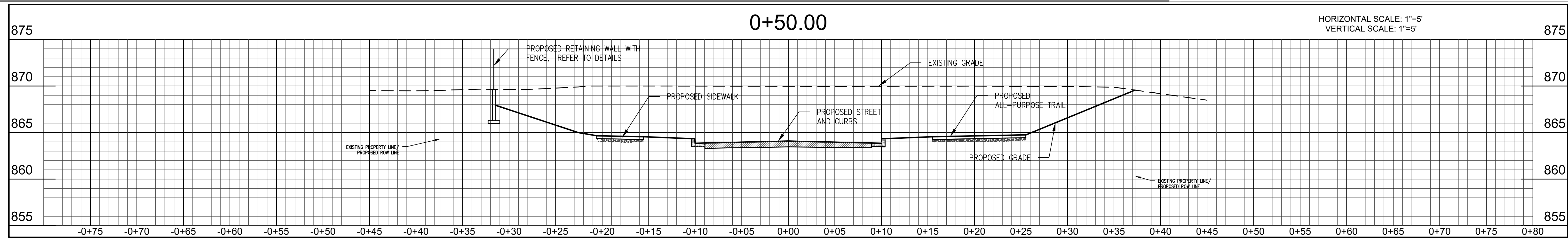

'MAIN ACCESS' ROAD CROSS SECTION AT STATION 0+50.00 FROM SHEET C501 STATIONING

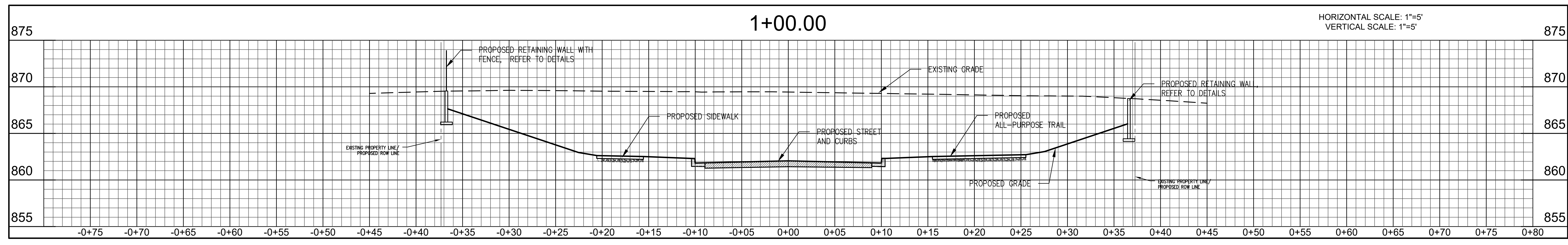

'MAIN ACCESS' ROAD CROSS SECTION AT STATION 1+00.00 FROM SHEET C501 STATIONING

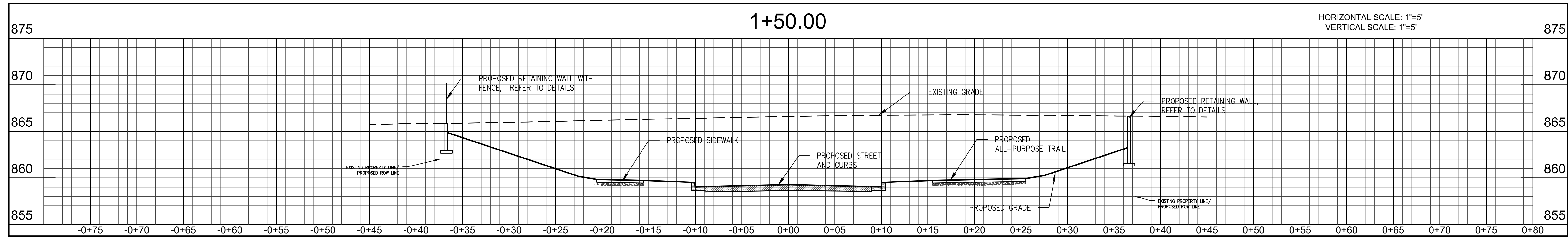

'MAIN ACCESS' ROAD CROSS SECTION AT STATION 1+50.00 FROM SHEET C501 STATIONING

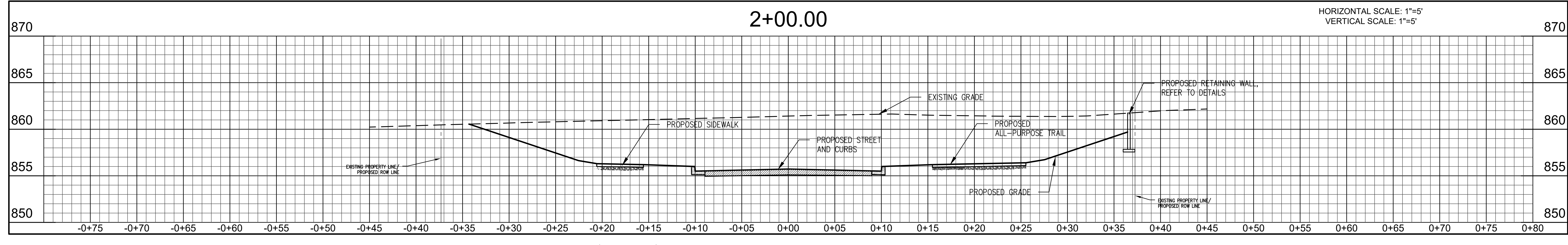

'MAIN ACCESS' ROAD CROSS SECTION AT STATION 2+00.00 FROM SHEET C501 STATIONING

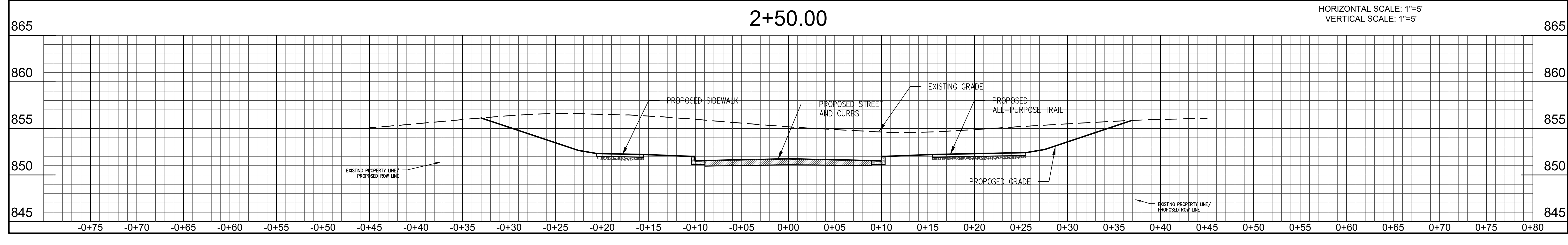

'MAIN ACCESS' ROAD CROSS SECTION AT STATION 2+50.00 FROM SHEET C501 STATIONING

Trinitas Development
West 17th Street PUD
17th & Arlington Plat
Bloomington, Indiana 47404
Facility Operation & Maintenance Plan
BFA Project Number 401334
January 5, 2021

Prepared by:
Bynum Fanyo & Associates, Inc.
528 N. Walnut Street
Bloomington, Indiana 47404

Introduction:

The property is located just north of the intersection of Arlington Park Drive and West 17th Street in Bloomington, Indiana in the SW quarter of Section 29, T9N, R1W, Bloomington Township (the "Property"). Six (6) new public access roads that will be dedicated public right of way will be established along with two (2) private access streets. The Property will contain 337 new units within new duplex buildings, apartment buildings, and townhome buildings. That will total 825 bedrooms along with access drives, 458 on-site parking stalls that are between street parking and private parking lots, and sidewalks. The property will also contain 45 new single family lots within these areas. Also, the Property will contain five new stormwater quality/detention ponds with sand filter strips for percolating stormwater through. These will be located on the western, northern, and southeast sides of the Property. There will also be a swimming pool courtyard with additional drainage structures located in the vicinity.

Purpose:

This facility maintenance plan was developed to specify pre-construction and construction standards as well as post-construction maintenance standards for the Property.

Pre-Construction:

Prior to commencement of construction activities a pre-construction meeting will be held with the contractor (operators & laborers), owner, engineer, architect, City Inspectors to go over the construction plans, erosion control plan, any necessary City Planning conditions and the expectations for the project in accordance with **327 IAC 15-5-7 (9)**.

During Construction:

Prior to commencing grading activities the contractor will be required to read and follow 'sequence' as outlined on the erosion control plan of the approved civil plan set. These practices will then be inspected and approved by the City of Bloomington Drainage Department as grading activities commence.

It is vital that the existing streams/conservancy areas on the Property be protected from sediment during construction. Install silt fence along the project side of this stream area prior to any grading activity. Install the sediment ponds/stormwater quality facilities and then a temporary drainage swales/berms with leading to it as described in the 'sequence' as it relates to grading activity. If after five years from the date of approval of this document, the project is not complete and the sediment ponds have not yet been converted into permanent water quality facilities or filled in as seen on the plans,

they shall be converted and planted with native seeds, native plugs, or native plantings at that time as indicated on the plan set.

During construction the contractor will be required to inspect and perform necessary maintenance of all erosion control structures weekly with weekly reports and also upon completion of every "major" rainfall event per **327 IAC 15-5-7 (18 A-C)**. A construction site inspection and maintenance log is required to document all information and inspection dates. Coordinate log with the City of Bloomington Utilities Drainage Department.

The contractor shall be responsible for maintaining each erosion control device in accordance with the erosion control plan prepared by Bynum Fanyo & Associates, Inc. and the October, 2007 edition of the **Indiana Department of Environmental Management Manual on Stormwater Quality**.

In order to prevent erosion of soil off site temporary seeding will be required in areas that are left inactive for fifteen (15) days or more in accordance with **327 IAC 15-5-7 (16)**. Specific seeding types will be dependant on the weather. During times of the year when soil temperatures are less than 50°F a Dormant and Frost Seeding mix shall be employed as detailed in the construction plans. When soil temperatures are above 50°F a Temporary Seeding Mix shall be employed as also specified in the construction plans.

Post-Construction (Owner Responsibilities):

At the completion of construction it will be the responsibility of the individual owners of the newly created lots by the plat to inspect, maintain and repair all landscaping, hardscaping, the water-quality/detention ponds, the swimming pool, and private watermains within their respective Areas of ownership. In the event that the Owner fails to meet these responsibilities the city is hereby granted the right to enter these lots and make any necessary maintenance repairs and recover its costs by billing the Owner of the lot or place a lien on the property when payment is not made in a timely manner. These will not be the responsibility of the 45 single family owner's lots.

All responsibilities for inspection, maintenance, and repair as well as their associated costs which shall be borne by the owner of each lot shall also be borne by any successors in interest to the lots.

Landscaping:

Once the site has been established all landscape maintenance will be provided by the Owner. The use of fertilizers and pesticides shall be used sparingly on the site.

The following is a listing of routine landscaping tasks and their maintenance frequency.

<u>Task</u>	<u>Frequency</u>
Mowing & Trimming	As needed depending upon growing season (once every two weeks min.)
Tree Pruning	As needed
Turf reseeding	as needed to maintain mature turf

These responsibilities will also include maintenance of tree plot mowing grass (not tree maintenance within the public ROW tree plots) within the public ROW within property limits along with the mowing and maintenance (not tree maintenance within the public ROW tree plots) of all the ROW green spaces that leads from the property premises to Arlington Road entrance (known as Telluride Street).

Hard-Scaping:

Hard-scaping includes sidewalks, all-purpose trails, patios, decks, and private parking surfaces. Surfaces shall not be allowed to accumulate significant amounts of debris such as leaves, sand, trash, and grass clippings. Surfaces shall also be cleared of snow in accordance with the City of Bloomington's Street Department guidelines by the owner. Weeds shall be manually removed from cracks in sidewalks and other concrete surfaces as needed. Graffiti shall be removed immediately after an occurrence. These responsibilities will also include maintenance of the all-purpose trail and sidewalk that leads from the property premises to Arlington Road entrance (known as Telluride Street).

Water Quality Detention Ponds located on-site (after construction completed):

Bi-Monthly inspections by the owner of the sand filter strips, under drains, plantings, and earthen dams will be completed. If any damage that has caused functionality to cease to these features then repairs or replacement shall be immediate. The underdrains and sand filter strips/filter fabric shall be replaced as detailed in the construction plan set if functionality has ceased even after cleaning them out. Functionality has ceased if the pooled water in the facilities does not drain within 24 hours of no additional rain events.

Sediment levels within the basin area shall also be monitored to not be allowed to accumulate to a depth above the 12" mark located on the permanent 2" diameter aluminum sediment stake. When sediment accumulates to the 12" mark then said sediment shall be removed and properly disposed to restore the pond to its design capacity.

The ponds were or will be planted with a native grass/forbe seed mix suitable for wet areas which assists in the stormwater quality treatment process. This planting shall be

monitored monthly and maintained by the owner or a company experienced with native plants to ensure a healthy establishment. Mowing in the stormwater quality facilities shall be permitted only in March or April. When sediment is removed as discussed above, the pond shall be replanted with the same or a City of Bloomington approved native seed/forbe mix.

Swimming Pool:

The owner or successors in interest to the Property shall check the pool area regularly to maintain cleanliness and standards set forth by:

Public and Semi-Public Swimming Pools Rule

410 IAC 6-2.1

**Indiana State Department of Health
Environmental Public Health Division**

2 N. Meridian St., 5-E

Indianapolis, IN 46204

Revision Effective: August 26, 2010

Easements:

All easements shall be per the City of Bloomington Unified Development Ordinance Standards as seen on the exhibits 1-3 except for the easements around the site as follows:

The area shown as Proposed Vail Street and Denver Road Ingress/Egress, Parking & Utility Easement on Exhibit 1 attached hereto and made a part hereof (the “Denver and Vail Easements”) shall be subject to the following:

- The general public shall have the right to access the Denver and Vail Easements for purposes of walking, running, bicycling, skating, and motorized vehicle use.
- The owner or successors in interest to the Property shall be responsible for snow removal, landscape maintenance, and hard-scape maintenance until such date as the Ronson Street Easement is dedicated to the City of Bloomington as right-of-way.
- The Property’s tenants, owners, or managers as authorized by the owner or successors in interest to the property shall be allowed to park vehicles in an area designated on the recorded plat.
- No unauthorized (by the property owner or successors in interest to the property) obstruction shall be placed within the easement area.

The area shown as Common Area Conservancy, Drainage & Floodplain Easement (the “Preservation Area”) on Exhibit 1 shall be subject to the following:

- Those certain standards set forth in Section 20.07.070(e)(10) of the Bloomington Unified Development Ordinance (“UDO”).
- No grading fill material of any kind shall be placed within the preservation area Easement.
- No obstruction that would impede stormwater drainage flow shall be placed within the preservation area Easement.

Private Water Main:

Within the property line of the Property, the 8” or 12” water main is private and shall be the owner’s responsibility or successors in interest to the Property for ongoing maintenance. All underground piping, hydrants, control valves, fire department connection and backflow devices located on the Property will be maintained per NFPA 25 including the operating and inspection of all control valves, fire hydrants, and fire department connections as well as testing of all double check valve assemblies annually. The reduced pressure backflow devices shall be tested semi-annually.

OWNER SIGNATURE:

The Property owner hereby agrees to the terms of this Facility Operation and Maintenance Plan and agrees to abide by the regulations set forth in this plan/recorded plat in perpetuity.

Owner of Lot #1:

Name _____ Representing: _____ Title: _____
Signature _____ Date: _____

Owner of Lot #2:

Name _____ Representing: _____ Title: _____
Signature _____ Date: _____

Owner of Lot #3:

Name _____ Representing: _____ Title: _____
Signature _____ Date: _____

Owner of Lot #4:

Name _____ Representing: _____ Title: _____
Signature _____ Date: _____

Exhibit 1:

PROPERTY LINE	---
EASEMENT LINE	---
FENCE	X-X
OVERHEAD UTILITIES	OHU
OVERHEAD ELECTRIC LINE	-E-
UNDERGROUND ELECTRIC LINE	UGE
UNDERGROUND GAS LINE	-GAS-
UNDERGROUND TELEPHONE LINE	UGT
WATER LINE	-W-
SANITARY SEWER LINE	-S-
DEED RECORD BOOK AND PAGE	XXX/XXX
5/8" REBAR WITH CAP SET	o 5
MAG NAIL SET	o MN
RECORD	R
MEASURED	M
RIGHT-OF-WAY	ROW
UTILITY POLE	o
FIRE HYDRANT	o
ELECTRIC METER	o
WATER METER	o
TELEPHONE RISER	o
ELECTRIC TRANSFORMER	o
STORM BASIN	o
WATER VALVE	o
SIGN	o
AREA LIGHT	o
SANITARY SEWER CLEAN OUT	o
CABLE T.V. BOX	o
GAS METER	o
LANDSCAPE AREA	o
INGRESS AND EGRESS EASEMENT	o
DRAINAGE AND UTILITY EASEMENT	o
UTILITY POLE ANCHOR	o
ANTENNA	o
MAIL BOX	o
AIR CONDITIONING PAD	o
GENERATOR	o
L.P. GAS TANK	o
HANDICAP PARKING SPACE	o

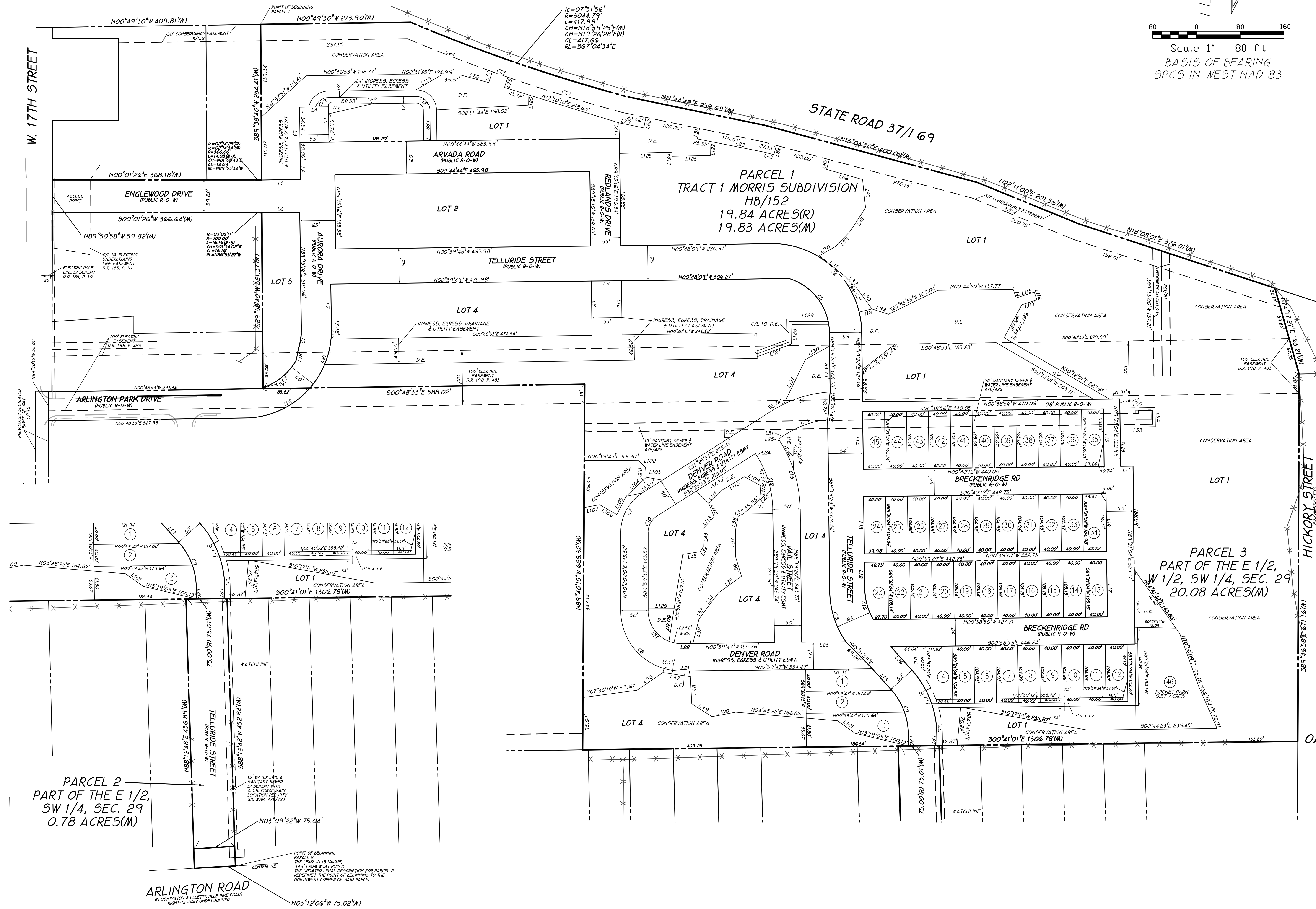
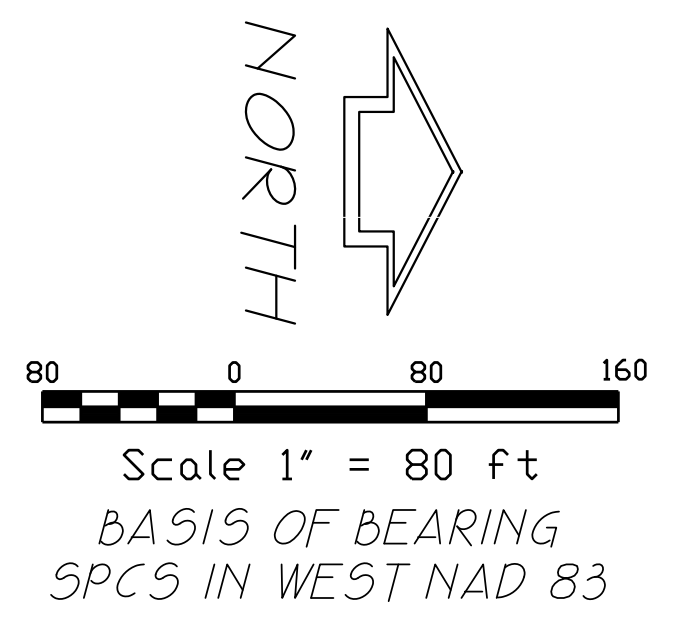

PARCEL 2
PART OF THE E 1/2,
SW 1/4, SEC. 29
0.78 ACRES(M)

ARLINGTON ROAD
(BLOOMINGTON & GLETTVILLE PIKE ROAD)
RIGHT-OF-WAY UNDETERMINED

17TH & ARLINGTON
PRELIMINARY PLAT
W 17TH STREET,
ARLINGTON ROAD &
STATE ROAD 37

DRAWING NO. 401334
SHEET 1 OF 2