

CITY OF BLOOMINGTON



May 20, 2021 @ 5:30 p.m.

Zoom Meeting:

<https://bloomington.zoom.us/j/96326624125?pwd=NjhrdE1va0JzOHlvcXpKcDg3MmlxZz09>

**CITY OF BLOOMINGTON
BOARD OF ZONING APPEALS
May 20, 2021 at 5:30 p.m.**

❖**Virtual Meeting:**

<https://bloomington.zoom.us/j/96326624125?pwd=NjhrdE1va0JzOHlvcXpKcDg3MmlxZz09>

ROLL CALL

APPROVAL OF MINUTES: November 19, 2021

REPORTS, RESOLUTIONS, AND COMMUNICATIONS:

PETITIONS CONTINUED TO: June 24, 2021

- CU/V-19-20 **Robert Iatarola**
1504 W. Arlington Rd.
Request: Conditional Use approval for a Home Occupation in the R2 zoning district. Also requested are variances to allow a Home Occupation to be located within an accessory structure and to allow deliveries (of pallets) to the property.
Case Manager: Ryan Robling
- V-05-21 **Nancy Armstrong**
619 S. Fess Ave.
Request: Variance from rear yard setback requirements for a detached Accessory Dwelling Unit (ADU).
Case Manager: Ryan Robling
- V-06-21 **David Kerber**
2400 W. 3rd St.
Request: Variance from front yard parking setback requirements.
Case Manager: Keegan Gulick
-

PETITIONS:

- AA-02-21 **Acacia Investments, LLC (Fairview Terrace)**
615 W. 15th St.
Request: Administrative Appeal of the Notice of Violation (NOV) for failure to comply with outdoor storage standards.
Case Manager: Liz Carter
- AA-03-21 **Whitehall Associates, L.P.**
3175 and 3755 W. 3rd St.
Request: Administrative Appeal of an administrative decision to deny a sign permit application.
Case Manager: Keegan Gulick

Petition Map: <https://arcg.is/1y18by>

****Next Meeting: June 24, 2021**

Auxiliary aids for people with disabilities are available upon request with adequate notice. Please call [812-349-3429](tel:812-349-3429) or e-mail human.rights@bloomington.in.gov.

BLOOMINGTON BOARD OF ZONING APPEALS
STAFF REPORT
Location: 615 W. 15th St.

CASE #: AA-02-21
DATE: May 20, 2021

PETITIONER: Acacia Investments LLC
403 E. 6th St. Bloomington, IN

REQUEST: The petitioner is requesting an administrative appeal from a Notice of Violation issued by staff.

REPORT: This appeal request is the result of issuance of a Notice of Violation related to outdoor storage compliance at 615 W. 15th Street. The property is located on the southeast corner of N. Fairview Street and W. 15th Street. This property is currently zoned Residential Small Lot (R3). The properties to the north, east, south, and west are zoned Residential Small Lot (R3). The violation is a result of a dumpster enclosure that does not meet development standards.

A grading permit was issued on July 17, 2019 for parking lot and site work taking place at 615 W. 15th Street, known as Fairview Terrace. The work included repaving and restriping the parking lot along with landscaping, bicycle parking, a dumpster enclosure, internal sidewalks, and compliant ADA-accessible parking.

On or about November 18, 2019, Planning and Transportation (the Department) staff inspected the site at 615 W. 15th Street for final occupancy at the request of a representative of the property management team. During the course of the inspection, a handful of deficiencies were identified that would prevent the site from receiving a final occupancy recommendation from the Department. One of the deficiencies was that the dumpster was not fully enclosed.

According to Unified Development Ordinance (UDO) Section 20.05.067 OT-03 [Outdoor Storage Standards; Trash Receptacles];

(b) Outdoor trash receptacles, dumpsters, compactors and similar containers shall be effectively screened on all sides by a fence or wall that is constructed of wood, brick, stone, chain link with opaque slats, or exterior building materials similar to those used on the primary structure. At least one (1) side of such fence or wall shall incorporate a movable gate for access.

(c) The height of the enclosure shall be a minimum of six (6) feet, and shall be high enough to ensure that the contents of the enclosure are not visible from adjacent parcels or public rights-of-way.

The UDO reference above is from the version of the UDO that was in place both when the grading permit was issued and when the occupancy inspection was conducted. The current UDO has the same requirements as they relate to dumpster enclosures found in Section 20.04.080(m)(3) [Development Standards & Incentives; Landscaping, Buffering, and Fences; Screening; Loading, Service, and Refuse Areas].

After delivering the findings from the inspection, the property manager communicated to staff that they did not agree with the Department's interpretation of the UDO. They wished to keep the

non-screened area to allow for the dumpster to be easily accessed by people with disabilities. Additionally, they felt that the enclosure was sturdy and aesthetically pleasing.

The enclosure was shown on the approved grading and site plan set as having a gap in the fencing material that enclosed it. However, there is also a retaining wall shown on the plans adjacent to the fencing enclosure location. The retaining wall is shown as surrounding the dumpster on 3 sides. Heights of neither the enclosure fencing nor the retaining wall were shown on the plan set. To meet UDO requirements either the enclosure or the retaining wall needed to create a complete six foot tall enclosed space around the dumpster area. Neither the enclosure nor the retaining wall do that.

A Notice of Violation warning was issued on January 6, 2021 so that the decision made by the Department that the dumpster enclosure was non-compliant could be appealed. Counsel for the property owner notified the Department in writing that they wished to appeal the Notice of Violation warning on January 13, 2021.

The owner has requested an appeal of the decision to that the dumpster enclosure is not compliant with Outdoor Storage Requirements as outlined in the UDO. The site has been out of compliance since at least November of 2019 when staff performed a requested occupancy inspection.

RECOMMENDATION: Based on the findings in this report, the Department recommends denial of Case # AA-02-21.

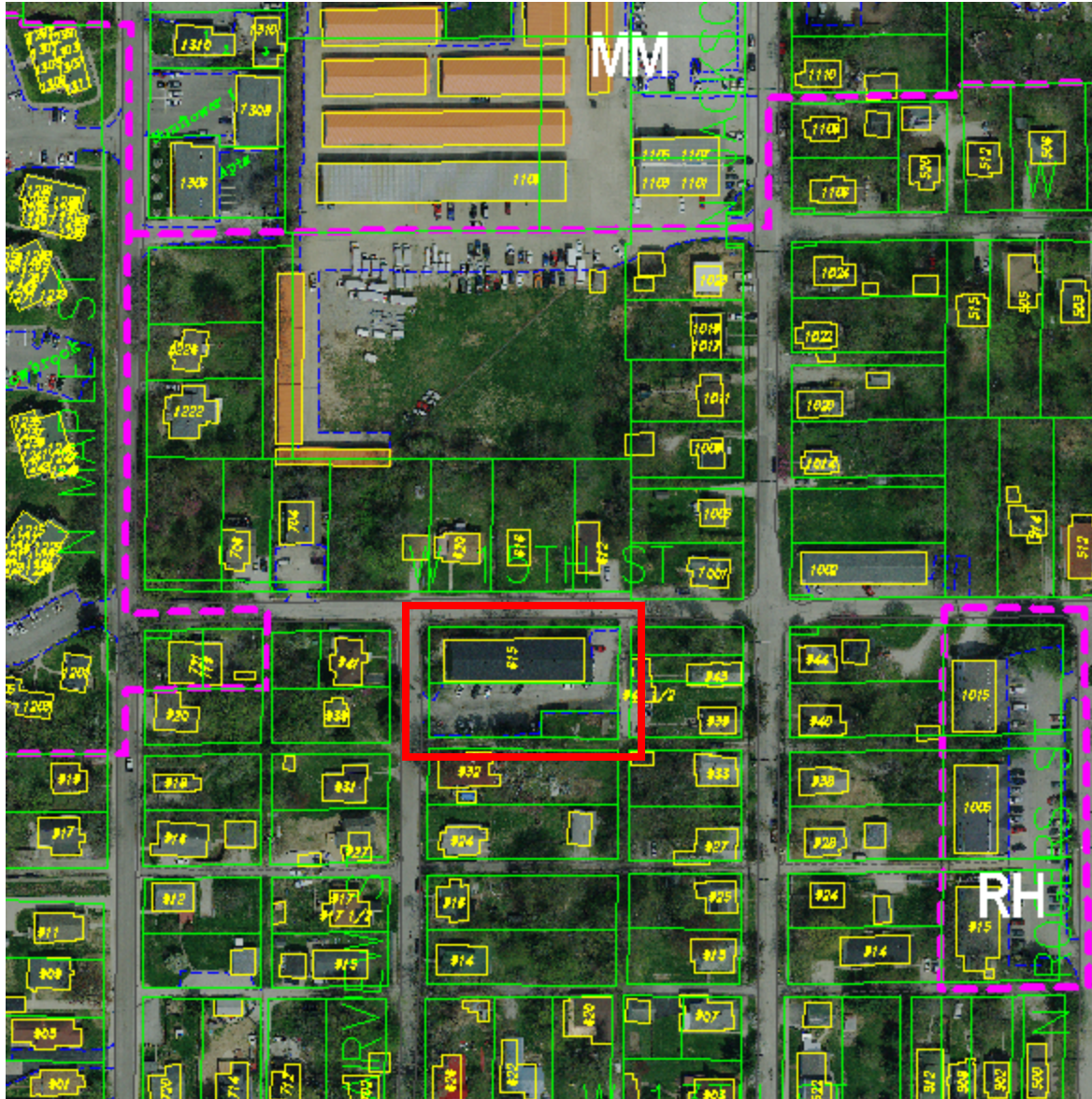

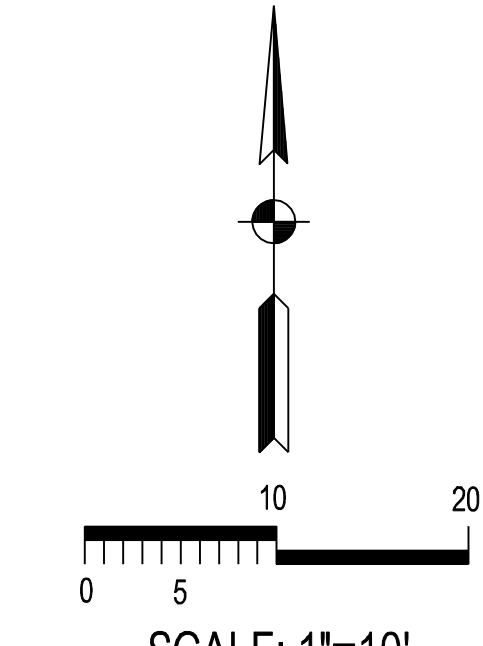
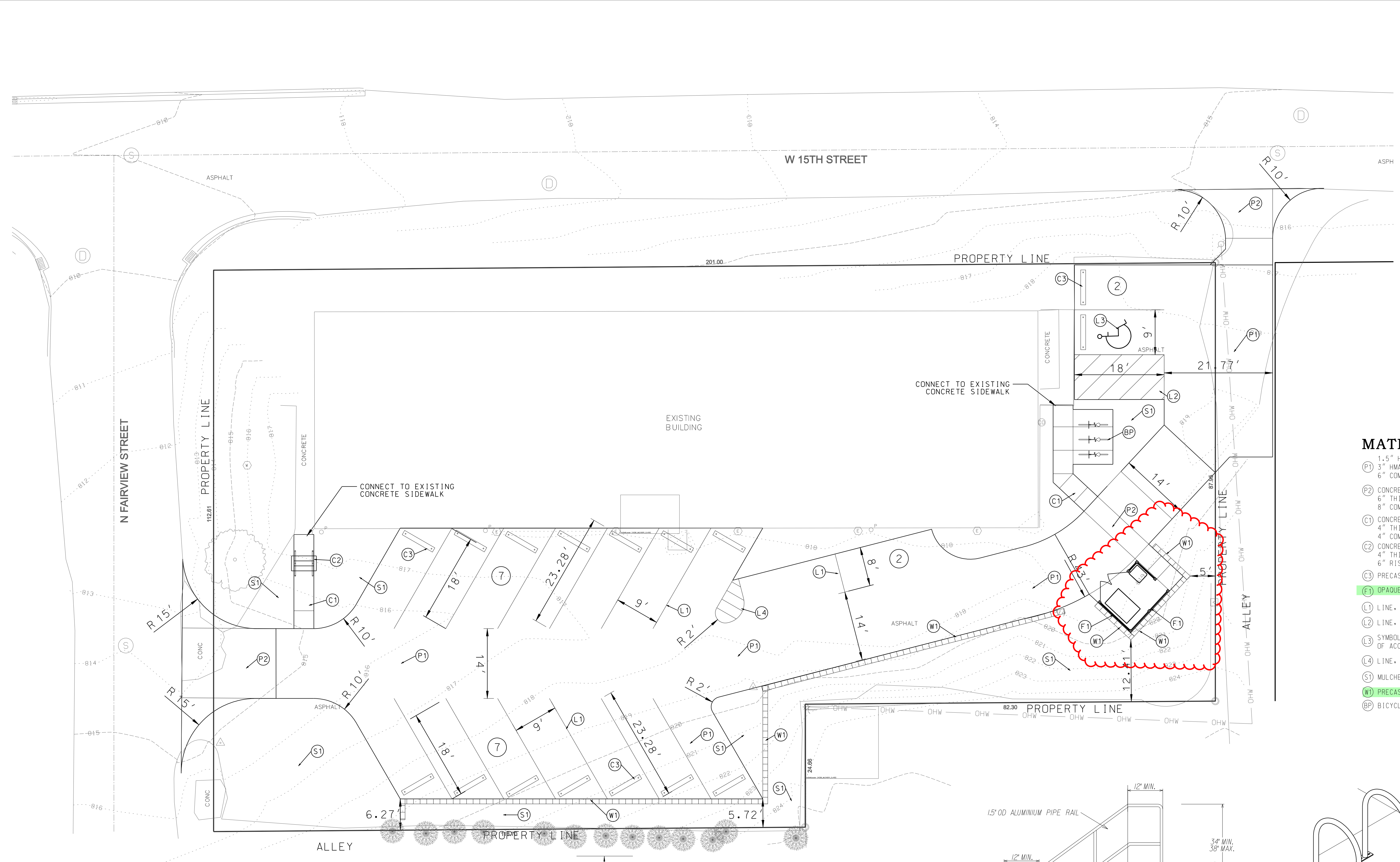

SCALE: 1"=10'

SITE LEGEND

- 10' DE DRAINAGE EASEMENT
- 10' DE UTILITY EASEMENT
- 10' DE DR. & UT. EASEMENT
- 2" ROLL CURB
- 2' CURB AND GUTTER
- 6" STANDING CURB
- CONCRETE SIDEWALK
- HANDICAPPED RAMP
- HANDICAPPED RAILING
- RET. WALL (CONCRETE)
- RET. WALL (MASONRY)
- RET. WALL (STONE)
- RET. WALL (WOOD)
- FENCE (BARB WIRE)
- FENCE (CHAIN LINK)
- FENCE (SMOOTH WIRE)
- FENCE (POST & RAIL)
- FENCE (WOOD SLAT)
- GUARD RAIL
- PROPOSED STREET TREE
- BOLLARD
- DUMPSTER (WOOD)
- DUMPSTER (MASONRY)

MATERIALS LEGEND

- 1.5" HMA SURFACE ON
- 3" HMA BASE ON
- 6" COMPACTED AGGREGATE BASE #53 / CRUSHED PAVEMENT
- CONCRETE SLAB
- 6" THICK, 4000 PSI CONCRETE
- 8" COMPACTED AGGREGATE BASE #53
- CONCRETE SIDEWALK - WIDTH VARIES
- 4" THICK CONCRETE
- 4" COMPACTED AGGREGATE BASE #53, TYPE "0"
- CONCRETE STAIRS
- 4" THICK CONCRETE
- 6" RISER, 12" TREAD
- PRECAST CONCRETE WHEEL STOPS
- OPAQUE WOODEN DUMPSTER ENCLOSURE
- LINE, PAINT, SOLID, WHITE, 4"
- LINE, PAINT, SOLID, BLUE, 6"
- SYMBOL, PAINT, BLUE, INTERNATIONAL SYMBOL OF ACCESSIBILITY
- LINE, PAINT, SOLID, YELLOW, 6" CROSSHATCH
- MULCHED SEEDING
- PRECAST CONCRETE MODULAR BLOCK WALL
- BICYCLE PARKING - HOOP RACK

Smith Brubaker & Associates, Inc.
 453 S. Claitor Boulevard
 Bloomington, Indiana 47401
 Telephone: (812) 336-6336
 Fax: (812) 336-0613
 Web: http://smibrubaker.com

STEPHEN L. SMITH
 REGISTERED PROFESSIONAL ENGINEER
 NO. PE60016166
 STATE OF INDIANA
 CERTIFICATION DATE: 11/08/17

**15TH AND FAIRVIEW
 PARKING LOT IMPROVEMENTS**

REVISIONS	BY	DATE

DESIGNED	CHECKED	DATE
SAB	SAB	

JOB NUMBER: 5547
 SHEET: C200
 DATE: 11/08/17
 SITE PLAN

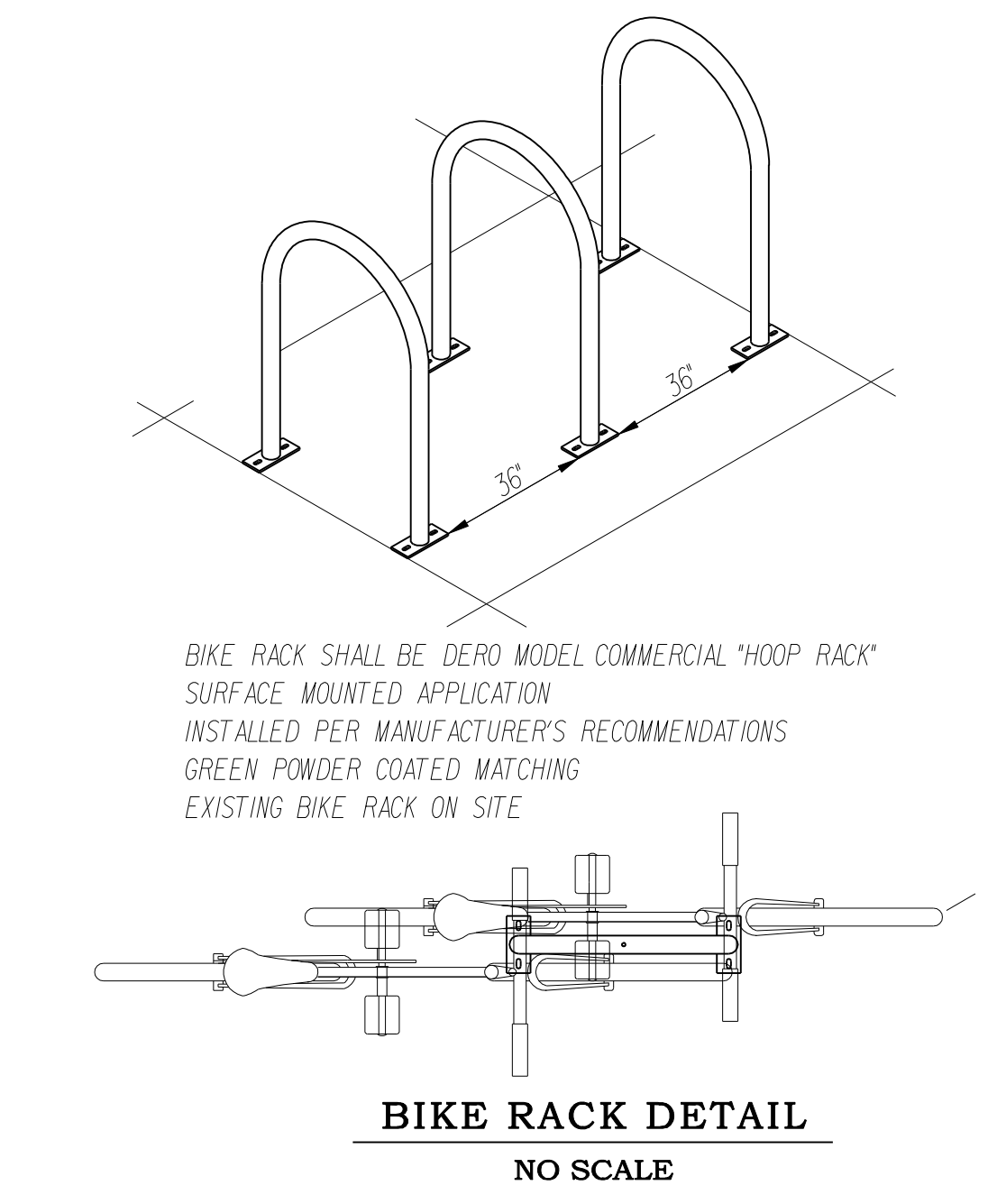
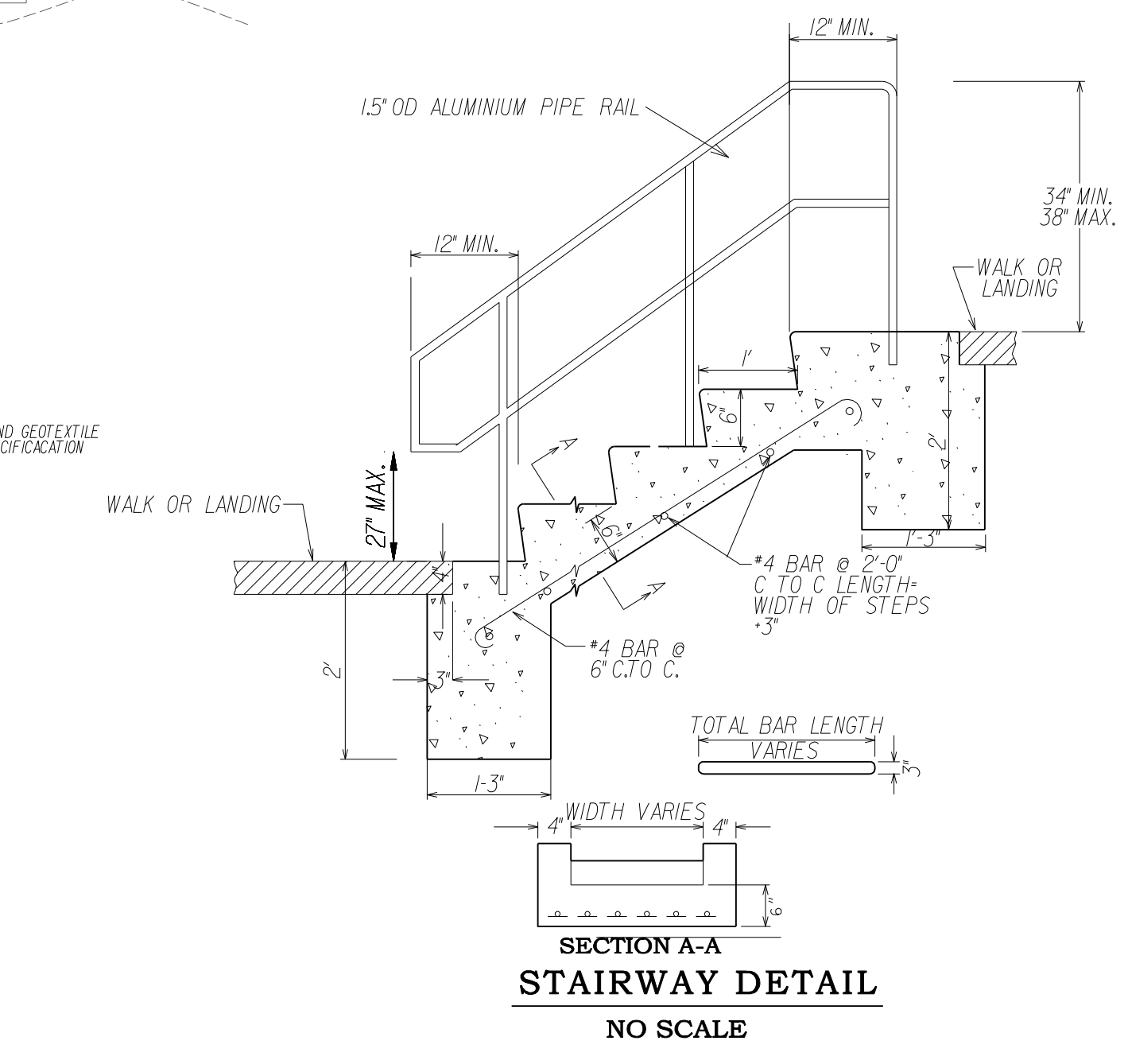
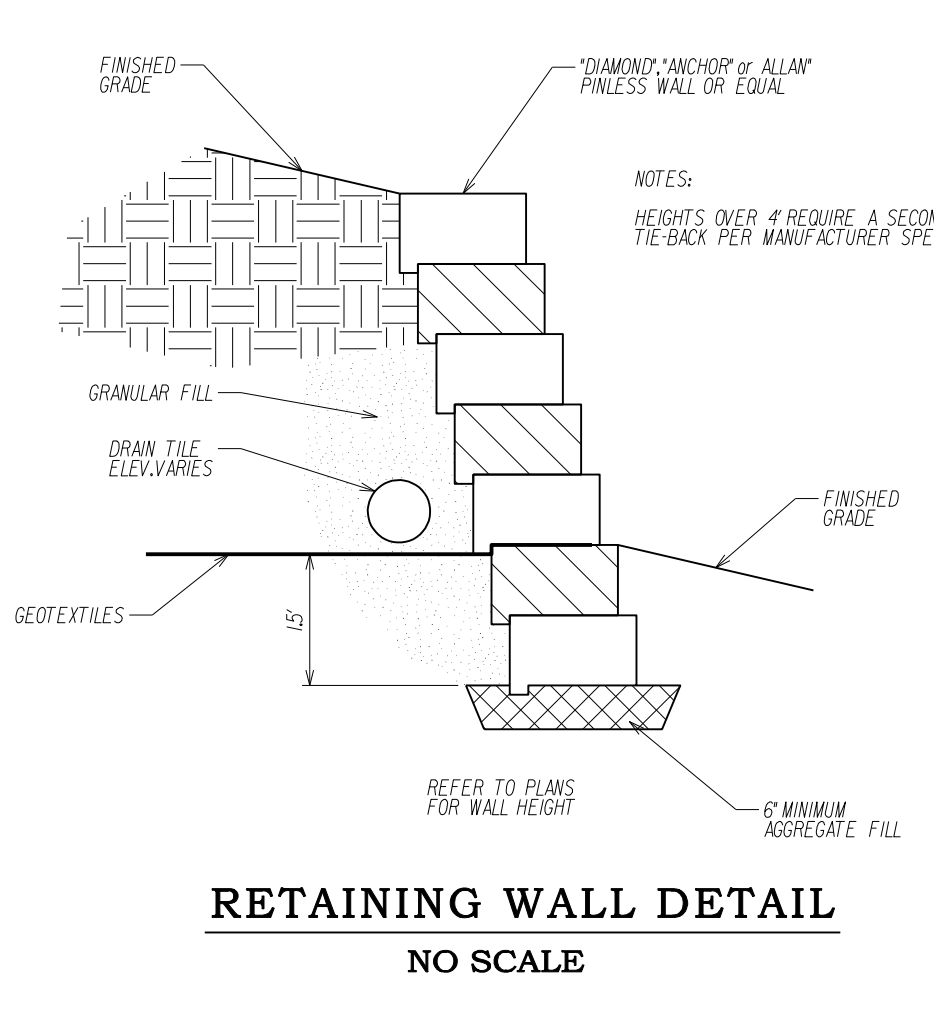
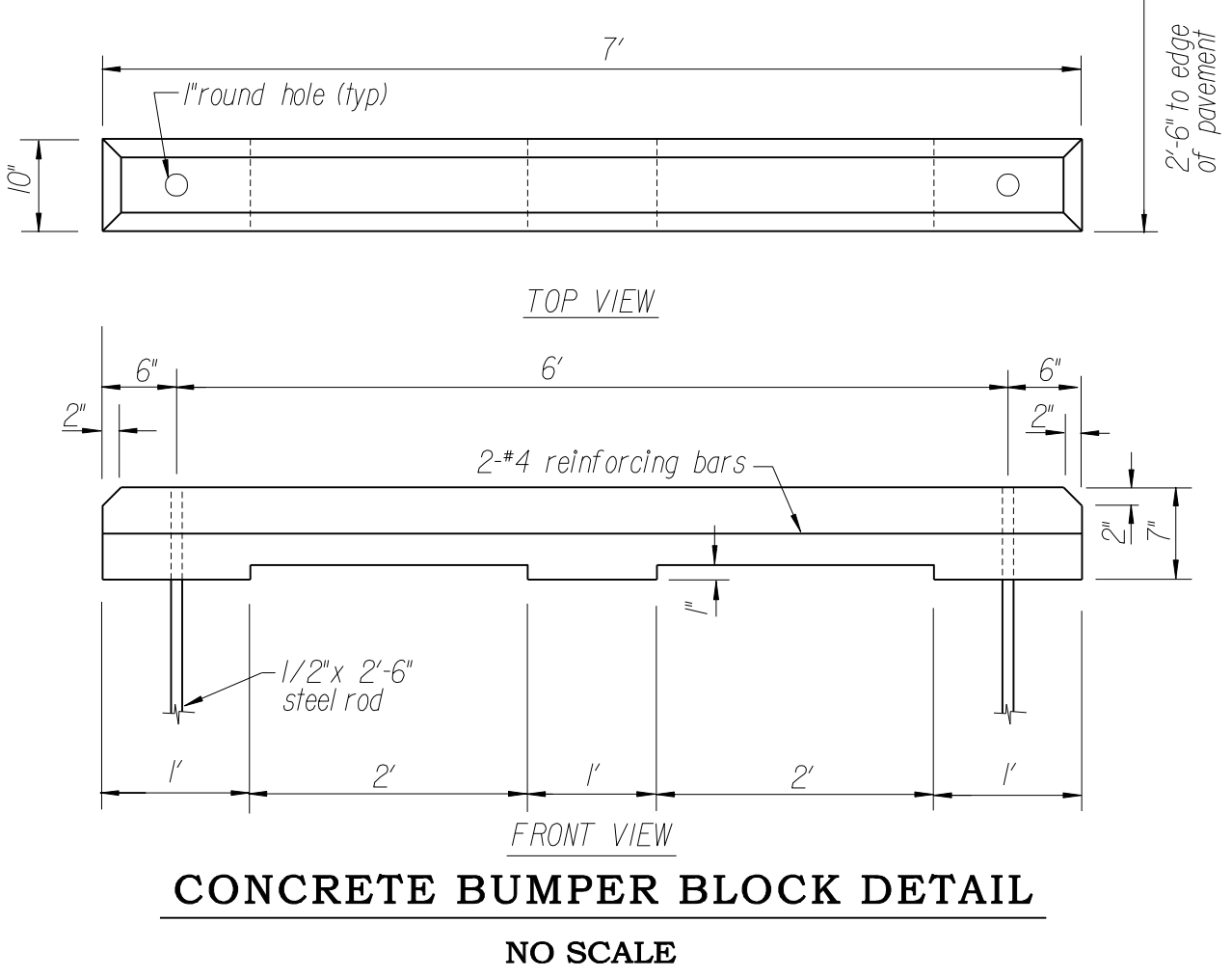
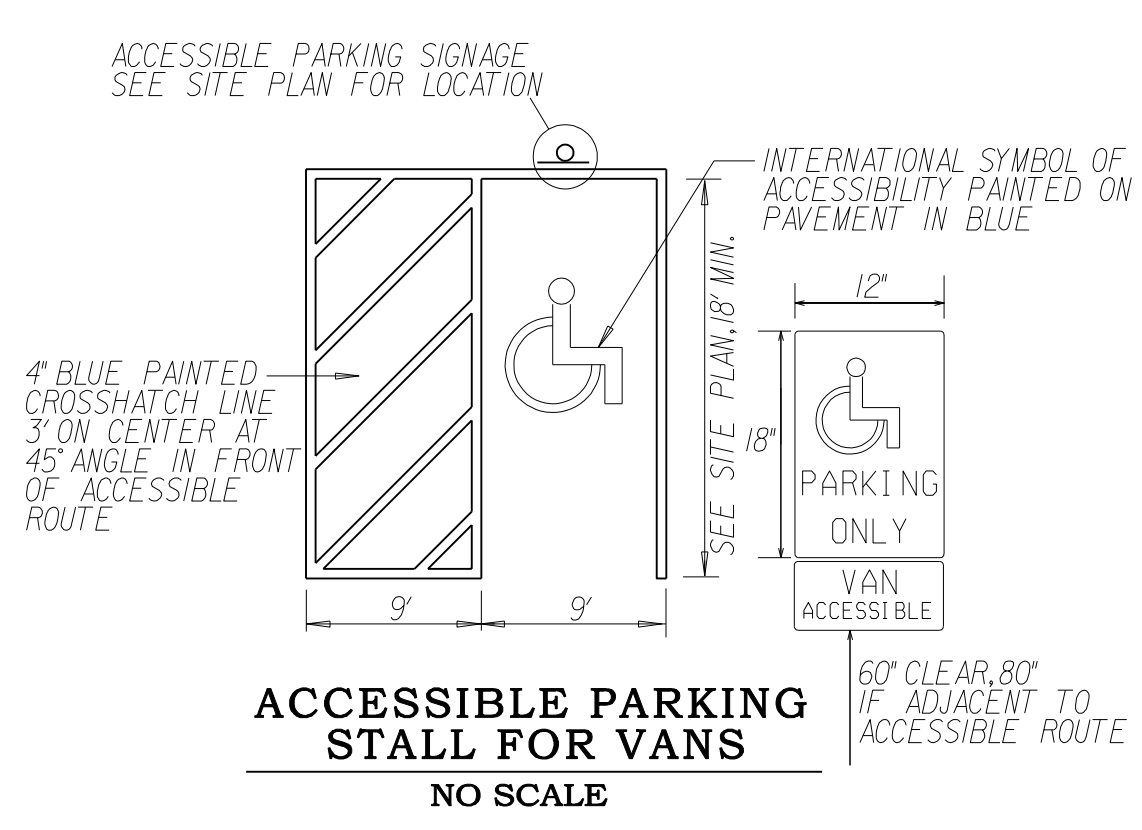



City of Bloomington
Planning and Transportation Department

January 6, 2021

Acacia Investments, LLC & Thomas Seeber
403 E. 6th St.
Bloomington, IN 47408

Fairview Terrace Apartments
615 W. 15th St.
Bloomington, IN 47404

Re: **Notice of Violation (Warning)**
Outdoor Storage Standards – 615 W. 15th St.

Dear Sir or Madam:

This Notice of Violation (NOV) serves as a formal warning of non-compliance with Unified Development Ordinance (UDO) **Section 20.05.067 OT-03 [Outdoor Storage Standards; Trash Receptacles]** at 403 E. 6th St. Records show that you are the owner of this property (or business) and the owner of the dumpster.

The City of Bloomington Planning and Transportation Department received an application for a final occupancy inspection for the site located at 615 W. 15th Street. Staff conducted an occupancy inspection on 11/19/2019 with the plan set that was approved with grading permit C17-462. Staff communicated that the dumpster enclosure observed on site was not compliant. Property management for the site did not agree that the dumpster enclosure was noncompliant. However, per the reference below, the existing enclosure does not meet UDO requirements.

According to Unified Development Ordinance (UDO) **Section 20.05.067 OT-03 [Outdoor Storage Standards; Trash Receptacles]**

- (a) Outdoor trash receptacles, dumpsters, compactors and similar containers shall be placed on a paved slab.
- (b) Outdoor trash receptacles, dumpsters, compactors and similar containers shall be effectively screened on all sides by a fence or wall that is constructed of wood, brick, stone, chain link with opaque slats, or exterior building materials similar to those used on the primary structure. At least one (1) side of such fence or wall shall incorporate a movable gate for access.
- (c) The height of the enclosure shall be a minimum of six (6) feet, and shall be high enough to ensure that the contents of the enclosure are not visible from adjacent parcels or public rights-of-way.
- (d) Outdoor trash receptacle or dumpster, compactor, and similar container enclosures shall meet the setback requirements in Chapter 20.05; §SB: Setback Standards.
- (e) Screened outdoor storage facilities shall be adequately protected from damage by vehicles through the installation of bollards and shall be properly maintained and kept in good repair at all times.

In accordance with UDO Section 20.10, a violation of this nature may result in a one-hundred dollar (\$100) fine. Each day a violation is allowed to continue is considered a distinct and separate violation. Subsequent violations are twice the previous fine, up to a maximum daily fine of seven thousand five hundred dollars (\$7,500).

No fines have been issued at this time. You have the following options to remedy the situation.

1. Complete the dumpster enclosure such that the dumpster is effectively screened on all sides by 1/20/2021 **OR**;
2. Make a phone appointment with a Planner to discuss filing a variance request. The appointment must be on or before 1/20/2021 for the 3/18/2021 Board of Zoning Appeals hearing.

If you dispute the City's assertion that the property is in violation of the above referenced sections of the Unified Development Ordinance, you may file an appeal with the City's Board of Zoning Appeals. Said appeal shall be filed with the Planning and Transportation Department within five (5) days of your receipt of this Notice of Violation and shall conform to the requirements of UDO Section 20.09.350.

Failure to resolve this violation may result in further enforcement action. If a fine is issued, the final fine amount shall be paid to the City of Bloomington. All fines may be contested in the Monroe County Circuit Courts.

Please contact the Planning and Transportation Department at planning@bloomington.in.gov or 812-349-3423 with any questions or concerns.

Sincerely,



Elizabeth Carter
Senior Zoning Compliance Planner, Planning and Transportation

CC: Scott Robinson, AICP
Jackie Scanlan, AICP



Figure 1: Dumpster is not enclosed on all sides with a minimum 6 foot enclosure.



Elizabeth Carter <cartere@bloomington.in.gov>

Fairview Terrace Apartments: Grading Permit Status

Christine Bartlett <CLB@ferglaw.com>
To: Liz Carter <cartere@bloomington.in.gov>
Cc: Property Manager <manager@olympusproperties.com>

Wed, Jan 8, 2020 at 3:19 PM

Ms. Carter,

I am writing regarding the dumpster enclosure at [615 W. 15th Street](#) (Fairview). I understand the City has not yet issued a Notice of Violation, but contends the new trash enclosure is in violation of Code.

We would like the City to reconsider its position on this. Fairview is considered a lawful nonconforming property. Before the parking lot work was done at Fairview, the dumpster had no enclosure and was placed back in different positions when it was emptied by the trash servicer. When the owner decided to improve the parking lot, the owner could have elected to not move the dumpster and not build an enclosure for the dumpster, as the parking lot work did not involve an addition to an existing building, a change of use, expansion, enlargement, or relocation of any use. The owner decided to move the dumpster because, in its original location, the elevations would not comply with the Americans with Disabilities Act (ADA). Rather than just moving the existing dumpster, the owner decided to build an enclosure.

Plans for the parking lot and the trash enclosure were submitted for approval to the City. The plans were approved and the enclosure was built according to those plans. As the plans indicated, the trash enclosure has a gate in front of the dumpster, which hides the dumpster from nearly every vantage point. The new enclosure was designed without a gate in front of the pedestrian entrance to comply with the ADA. An individual in a wheelchair or with limited strength or mobility would have difficulty opening up the large gate, so the pedestrian access allow greater accessibility.

The trash enclosure looks great and is a noticeable improvement. I am including a photograph of the dumpster before the parking lot work and several of the enclosure. As you can see, the dumpster is not visible from most vantage points. The pedestrian opening, which is only 3 feet wide, does not provide much visibility of the dumpster, as the dumpster area is separately walled off other than an L shaped pedestrian access. The dumpster is not visible from the public road. The dumpster is only visible from a very limited vantage point in the alley/driveway next to the property. If you are standing in the spot where the dumpster is visible and turn around, there are three trash toters sitting next to a house with no enclosure and no attempt has been made to conceal them from the public road or the neighboring properties.

We believe the enclosure has improved the appearance of the property and has improved accessibility for individuals with disabilities to access the dumpster. Requiring a gate will limit that accessibility and we ask that the City reconsider its position on the property's compliance.

Thank you,
Christine





[Quoted text hidden]

--

Christine L. Bartlett
Ferguson Law
403 E Sixth Street
Bloomington, IN 47408
p: 812.332.2113 ext 205
f: 812.334.3892
e: clb@ferglaw.com

[Quoted text hidden]

 **Fairview Lot.pdf**
3223K

BLOOMINGTON BOARD OF ZONING APPEALS**STAFF REPORT****Location:** 3477 W 3rd St.**CASE #: AA-03-21****DATE: May 20, 2021**

PETITIONER: Whitehall Associates LP
3175 W 3rd St. Bloomington, IN

REQUEST: The petitioner is requesting an administrative appeal from a decision to deny a sign permit application.

REPORT: This appeal request is the result of an administrative decision to deny a sign permit application at 3477 W 3rd Street. The property is located on the southwest corner of W 3rd Street and I-69. This property is currently zoned as a Planned Unit Development (PUD). The properties to the north, east, south, and west are zoned Planned Unit Development (PUD).

The PUD allows four pole signs to be developed. Three pole signs have been permitted and existing on site since the 1980s. The fourth and final pole sign was applied for on November 25, 2020 and permitted on February 9, 2021.

A sign permit application for the property at 3477 W 3rd St. was received on February 9, 2021 and denied on February 23, 2021 because the allowable signage for the PUD has been used, so no new signage could be permitted at this time.

The petitioner has requested an appeal of the decision to deny sign permit application C21-060.

RECOMMENDATION: Based on the findings in this report, the Department recommends denial of Case # AA-03-21.

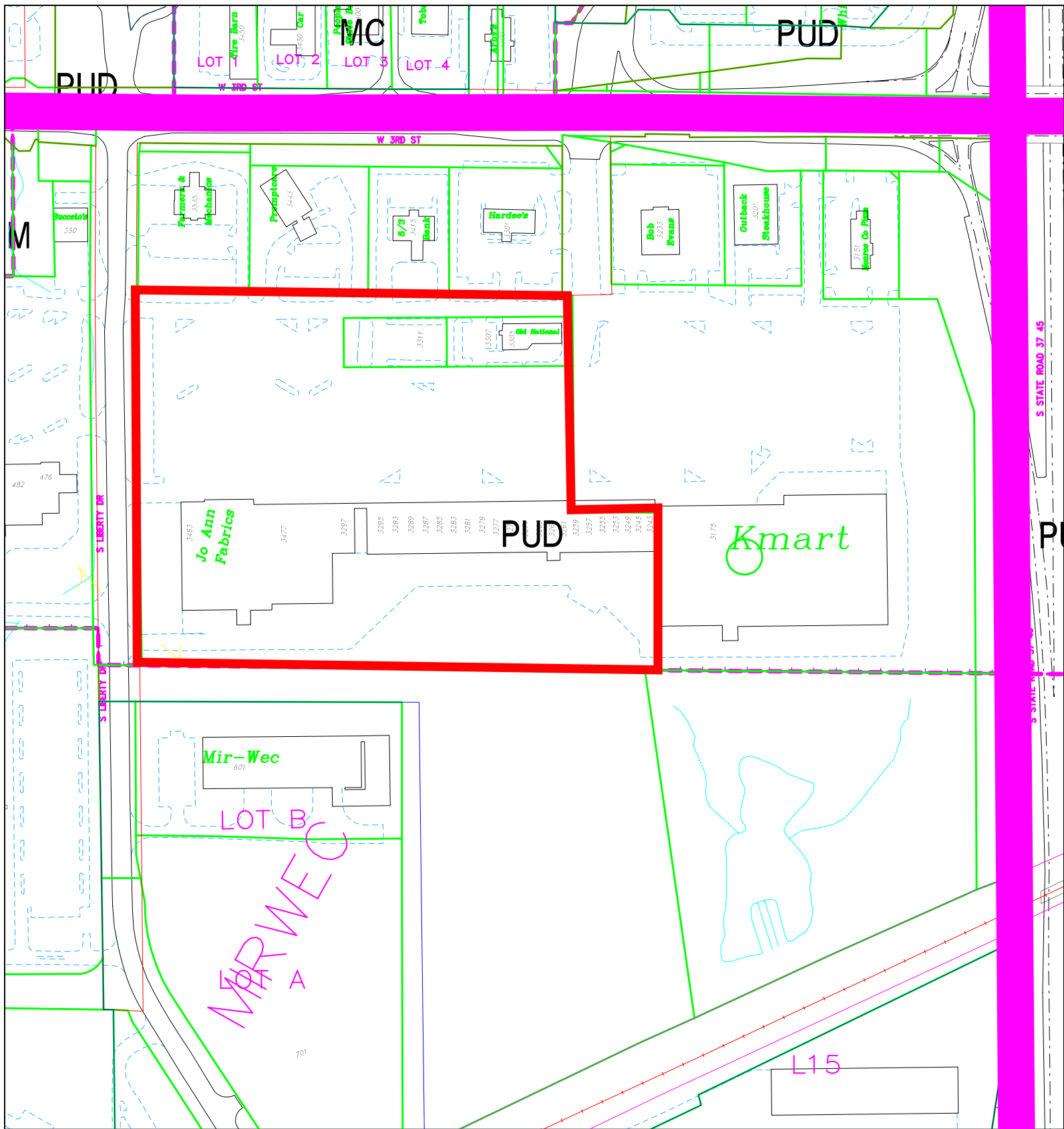

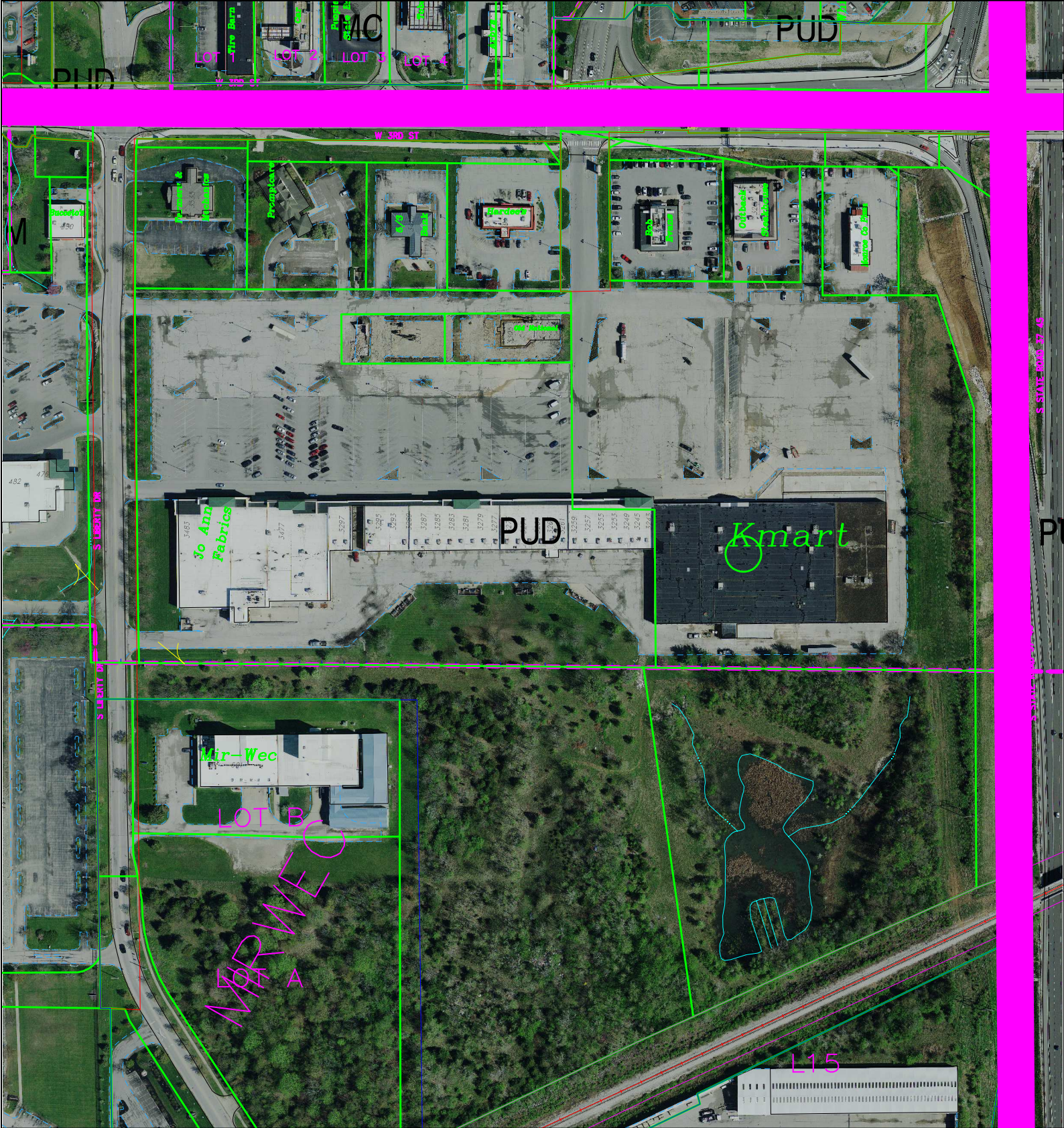



CITY OF BLOOMINGTON
Planning and Transportation Department
401 N. Morton St., Bloomington, Indiana 47404



Phone: 812-349-3423

Fax: 812-349-3520

Email: planning@bloomington.in.gov

APPLICATION FOR PERMANENT SIGN PERMIT

*** MAKE CHECKS PAYABLE TO THE CITY OF BLOOMINGTON**

Date Applied: _____
 Name of Business: _____
 Type of Business Use: _____
 Address of Business: _____
 Business Phone: _____
 Alternative Phone/Fax: _____
 Name of Applicant: _____
 Applicant Phone: _____

<p>(OFFICE USE ONLY) Application #: _____ Permit Fee: \$125.00 per sign Total Fee: _____ Date Issued: _____ Permit Reviewer: _____</p>
--

A SCALED SITE PLAN IS REQUIRED WITH YOUR APPLICATION.

In order to receive a **permanent sign permit**, the applicant shall submit a site plan containing the following elements:

1. Scale and North arrow;
2. Location of building(s), driveway(s), and parking area(s);
3. Location and size (in square feet) of all existing sign(s);
4. Indicate type of existing sign(s): wall, pole, or ground signage;
5. Location and dimensions of proposed sign(s);
6. Distance between building and proposed sign location(s);
7. Name and location of adjacent street frontage(s), if applicable; and
8. Distance between curb edge and sign location.

CERTIFICATION

I am the owner or authorized agent responsible for compliance, and hereby acknowledge the following:

1. I have read this application and all related documentation and I represent that the information furnished is correct.
2. I agree to comply with all City ordinances and State statutes, which regulate construction, land use, and occupancy.
3. Any changes made to sign dimensions or location shall be submitted to the City of Bloomington for review.
4. If any misrepresentation is made in this application, the City may revoke any Certificate issued based upon this misinformation.
5. No sign installation is allowed until a permit has been issued by the Planning and Transportation Department.

Applicant's Signature _____

Date _____

If you have questions about sign ordinance requirements, please call the **Bloomington Planning and Transportation Department @ 812-349-3423.**



City of Bloomington
Planning and Transportation Department
Permanent Sign Permit

Application #:	C20-677	Property Address:	3175 W 3rd Street
Date Received:	11/25/2020	Date Issued:	2/9/2021
Zoning District:	PUD	Proposed Use:	Retail sales, big box

This permit approves:

125 Square Foot	Freestanding Sign
-----------------	-------------------

The attached plans have been reviewed for compliance with applicable provisions of Title 20, Bloomington Unified Development Ordinance, and conformance with the terms of any approvals which have been granted under authority of the Ordinance. The Planning and Transportation Department finds the plans to be in compliance. The following terms and conditions apply:

- Signs that have intermittent blinking, flashing, or fluttering lights, including any device that has a changing light intensity, brightness of color, or gives such illusion, including but not limited to strobe lights. [BMC 20.04.100(e)(6)]
- For new freestanding signs, a landscaped area consisting of shrubs, spread no greater than 3 feet on center, and densely planted ground cover is required. The landscaped area shall be greater than or equal to the sign face area. [BMC 20.04.100(g)(1)(E)]
- Window signs shall not exceed 25 percent of the glass area of any individual window or glass door frame and shall not count towards the wall sign allowance of the use or property. [BMC 20.04.100(c)(2)(E)]
- All lighting fixtures shall be installed so that light trespass from any property line, except a property line abutting a public street, shall not exceed one footcandle at a point one meter beyond the property line. [BMC 20.040.090(c)(4)(A)]

This permit does not constitute the issuance of any additional required permits nor exempt the property from compliance with any requirements of other governmental entities.

Keegan Gulick
 Long Range and Zoning Planner
 City of Bloomington
 Planning and Transportation Department

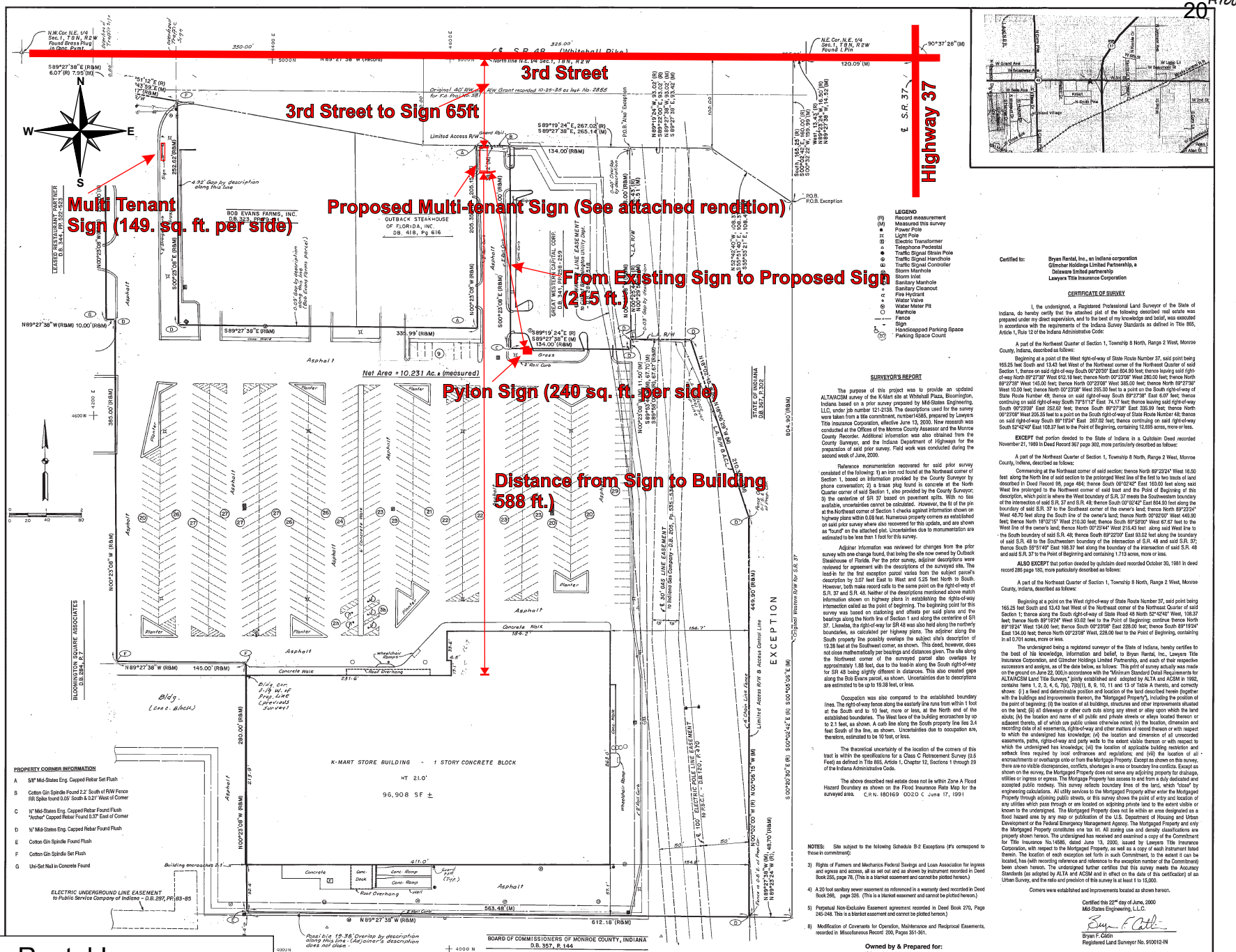

**Bryan Rental Inc.
3175 W. Third St.
Proposed New Sign
In addition to Existing Signs**

465	Regular
5	Handicapped
470	TOTAL

Revisions and Dates:	

Designed by:
Drawn by:
Checked by:
Approved by:



Mid-States
ENGINEERING
350 E. New York St., Suite 300
Bloomington, Indiana 47404
(317) 834-1434 Phone
(317) 834-3576 Fax

Title: **ALTA/ACSM LAND TITLE SURVEY**
K-Mart at Whitehall Plaza
S.R. 37 and S.R. 48
Bloomington, Indiana
Pt. of the N.E. 1/4 Sec. 1, T.8N, R.2W of the 2nd P.M.
Van Buren Township, Monroe County, Indiana
Scale: 1"=40'±

LEGEND

- (R) Record measurement
- (M) Measured the Survey
- (P) Power Pole
- (L) Light Pole
- (E) Electric Transformer
- (T) Telephone Pedestal
- (C) Traffic Signal Control Pole
- (S) Storm Manhole
- (F) Traffic Signal Handhole
- (I) Inlet
- (M) Manhole
- (W) Water Meter Pit
- (V) Valve
- (F) Fence
- (S) Sign
- (H) Handicapped Parking Space
- (C) Parking Space Count

SURVEYORS REPORT

The purpose of this project was to provide an updated ALTA/ACSM survey of the K-Mart at Whitehall Plaza, Bloomington, Indiana based on a prior survey prepared by Mid-States Engineering, L.L.C. on number 02-2338. The descriptions used for the survey were taken from a file commitment, number 0465, prepared by Lawyers Title Insurance Corporation, effective June 13, 2000. New research was conducted at the Office of the Monroe County Assessor and the Monroe County Recorder. Additional information was also obtained from the State Surveyor, and the Indiana Department of Highway for the preparation of said prior survey. Field work was conducted during the second week of June 2000.

CERTIFICATE OF SURVEY

I, the undersigned, a Registered Professional Land Surveyor of the State of Indiana, do hereby certify that the attached plat of the following described real estate was prepared under my direct supervision, and to the best of my knowledge and belief, was associated in accordance with the requirements of the Indiana Survey Statutes as defined in The 856, Article 4, Title 2 of the Indiana Administrative Code:

A part of the Northeast Quarter of Section 1, Township 8 North, Range 2 West, Monroe County, Indiana, described as follows:
Beginning at a point of the West right-of-way of State Route 37, said point being 165.25 feet South and 134.5 feet West of the Northeast corner of the Northeast Quarter of said Section 1, thence on said right-of-way South 00°29'30" East 804.30 feet, thence bearing said right-of-way North 89°27'36" East 415.18 feet, thence North 00°29'30" West 280.00 feet, thence North 89°27'36" West 145.00 feet, thence North 00°29'30" West 385.00 feet, thence North 89°27'36" West 100.00 feet, thence North 00°29'30" East 141.19 feet, thence bearing said right-of-way South 00°29'30" East 252.62 feet, thence South 89°27'36" East 335.99 feet, thence North 00°29'30" West 205.00 feet to a point on the South right-of-way of State Route 48, thence on said right-of-way South 89°19'24" East 207.25 feet, thence on said right-of-way South 52°42'49" East 103.87 feet to the Point of Beginning, containing 12,699 acres, more or less.

A part of the Northeast Quarter of Section 1, Township 8 North, Range 2 West, Monroe County, Indiana, described as follows:
Commencing at the Northeast corner of said section, thence North 89°27'36" West 16.50 feet along the North line of said section to the prolonged West line of the two-block of land described in Deed Record 58, page 486, thence South 00°29'30" East 150.00 feet along said West line prolonged to the Northeast corner of said tract and the Point of Beginning of the description, which point is where the West boundary of S.R. 37 meets the Southwest boundary of the intersection of said S.R. 37 and S.R. 48, thence South 00°29'30" East 684.58 feet along the boundary of said S.R. 37 to the Southeast corner of the owner's land, thence North 89°27'36" West 48.70 feet along the South line of the owner's land, thence North 00°29'30" West 448.00 feet, thence North 13°32'17" West 13.38 feet, thence North 89°27'36" West 87.18 feet to the South line of the owner's land, thence North 00°29'30" West 215.43 feet, along said West line to the South boundary of said S.R. 48, thence North 89°27'36" East 610.02 feet to the boundary of said S.R. 48 to the Southwest boundary of the intersection of S.R. 48 and said S.R. 37, thence South 89°19'24" East 103.87 feet along the boundary of the intersection of said S.R. 37 and said S.R. 48 to the Point of Beginning, containing 1.713 acres, more or less.

The undersigned being a registered surveyor of the State of Indiana, hereby certifies to the best of his knowledge and belief, by Bryan Rental, Inc., Lawyers Title Insurance Corporation, and Glenhairs Holdings Limited Partnership, and each of their respective successors and assigns, as of the date hereof, that the survey was made by a duly qualified and associated public professional. This survey reflects boundary lines of the land, which "shown" by engineering calculations. An ally service to the Mortgaged Property either after the Mortgaged Property through adjoining public streets, or this survey shows the point of entry and location of any utility which passes through or is located on adjoining private land in the extent visible or known to the undersigned. The Mortgaged Property does not include any area designated as a flood hazard area by any map or publication of the U.S. Department of Housing and Urban Development or the Federal Emergency Management Agency. The Mortgaged Property and only the Mortgaged Property constitutes one tax lot. All zoning and density classifications are hereby shown hereto. The undersigned has received and assumed a copy of the Commitment for Title Insurance No. 0465, dated June 13, 2000, issued by Lawyers Title Insurance Corporation, with respect to the Mortgaged Property, and has assumed a copy of the Commitment for Title Insurance No. 0465, dated June 13, 2000, issued by Lawyers Title Insurance Corporation, with respect to the Mortgaged Property, and has assumed a copy of the Commitment. The location of each exception set forth in such Commitment, to the extent it can be located, has with necessary reference and reliance on the accession number of the Commitment been shown hereto. The undersigned further certifies that this survey meets the Minimum Standards (as adopted by ALTA and ACSM and in effect on the date of this certification) of an Urban Survey, and the date and condition of this survey is at least to 1:10,000.

Conveyors were established and improvements located as shown herein.

Noted: Site subject to the following Subchapter B Exemptions (if so corresponded to those in commitment):
 1) Rights of Farmers and Mechanics Federal Savings and Loan Association for liens on real estate.
 2) Partial Non-Exclusive Easement agreement recorded in Deed Book 270, Page 264.
 3) Modification of Easements for Operation, Maintenance and Pedestrian Easements, recorded in Miscellaneous Record 200, Pages 351-351.

Owned by & Prepared for:
Glenhairs Holdings Limited Partnership

Created this 22nd day of June, 2000
Mid-States Engineering, L.L.C.
Brian F. Glan
Registered Land Surveyor No. 910012-N



CITY OF BLOOMINGTON
Planning and Transportation Department
401 N. Morton St., Bloomington, Indiana 47404



Phone: 812-349-3423

Fax: 812-349-3520

Email: planning@bloomington.in.gov

APPLICATION FOR PERMANENT SIGN PERMIT

*** MAKE CHECKS PAYABLE TO THE CITY OF BLOOMINGTON**

Date Applied: February 9, 2021
 Name of Business: Whitehall Associates
 Type of Business Use: Location signage
 Address of Business: 3477 W. Third Street
 Business Phone: (317) 595-8600
 Alternative Phone/Fax: (317) 223-1309
 Name of Applicant: Whitehall Assoc. LP
 Applicant Phone: (317) 595-8600

(OFFICE USE ONLY)
Application #: _____
Permit Fee: <u>\$125.00 per sign</u>
Total Fee: _____
Date Issued: _____
Permit Reviewer: _____

A SCALED SITE PLAN IS REQUIRED WITH YOUR APPLICATION.

In order to receive a **permanent sign permit**, the applicant shall submit a site plan containing the following elements:

1. Scale and North arrow;
2. Location of building(s), driveway(s), and parking area(s);
3. Location and size (in square feet) of all existing sign(s);
4. Indicate type of existing sign(s): wall, pole, or ground signage;
5. Location and dimensions of proposed sign(s);
6. Distance between building and proposed sign location(s);
7. Name and location of adjacent street frontage(s), if applicable; and
8. Distance between curb edge and sign location.

CERTIFICATION

I am the owner or authorized agent responsible for compliance, and hereby acknowledge the following:



1. I have read this application and all related documentation and I represent that the information furnished is correct.
2. I agree to comply with all City ordinances and State statutes, which regulate construction, land use, and occupancy.
3. Any changes made to sign dimensions or location shall be submitted to the City of Bloomington for review.
4. If any misrepresentation is made in this application, the City may revoke any Certificate issued based upon this misinformation.
5. No sign installation is allowed until a permit has been issued by the Planning and Transportation Department.

Applicant's Signature _____

Date _____

2/8/2021

If you have questions about sign ordinance requirements, please call the **Bloomington Planning and Transportation Department @ 812-349-3423.**

 South Branch & Associates, Inc. 1515 W. 10th Street Bloomington, MN 55408 Tel: 612-251-2222 Fax: 612-251-2228 www.southbranch.com	SCALE: 1"=40'  N	WHITEHALL PLAZA OUTLET SEC 1-T8N-R2W	REVISIONS <table border="1"> <tr> <th>NO.</th> <th>DATE</th> <th>DESCRIPTION</th> </tr> <tr> <td> </td> <td> </td> <td> </td> </tr> </table>	NO.	DATE	DESCRIPTION				DRAWN BY: DK CHECKED BY: DK DATE: 06/25/2018 SHEET: 2 of 6 EXISTING CONDITIONS
NO.	DATE	DESCRIPTION								

- LEGEND**
- 1. 2" LINE
 - 2. 4" LINE
 - 3. 6" LINE
 - 4. 8" LINE
 - 5. 10" LINE
 - 6. 12" LINE
 - 7. 14" LINE
 - 8. 16" LINE
 - 9. 18" LINE
 - 10. 20" LINE
 - 11. 22" LINE
 - 12. 24" LINE
 - 13. 26" LINE
 - 14. 28" LINE
 - 15. 30" LINE
 - 16. 32" LINE
 - 17. 34" LINE
 - 18. 36" LINE
 - 19. 38" LINE
 - 20. 40" LINE
 - 21. 42" LINE
 - 22. 44" LINE
 - 23. 46" LINE
 - 24. 48" LINE
 - 25. 50" LINE
 - 26. 52" LINE
 - 27. 54" LINE
 - 28. 56" LINE
 - 29. 58" LINE
 - 30. 60" LINE
 - 31. 62" LINE
 - 32. 64" LINE
 - 33. 66" LINE
 - 34. 68" LINE
 - 35. 70" LINE
 - 36. 72" LINE
 - 37. 74" LINE
 - 38. 76" LINE
 - 39. 78" LINE
 - 40. 80" LINE
 - 41. 82" LINE
 - 42. 84" LINE
 - 43. 86" LINE
 - 44. 88" LINE
 - 45. 90" LINE
 - 46. 92" LINE
 - 47. 94" LINE
 - 48. 96" LINE
 - 49. 98" LINE
 - 50. 100" LINE
 - 51. 102" LINE
 - 52. 104" LINE
 - 53. 106" LINE
 - 54. 108" LINE
 - 55. 110" LINE
 - 56. 112" LINE
 - 57. 114" LINE
 - 58. 116" LINE
 - 59. 118" LINE
 - 60. 120" LINE
 - 61. 122" LINE
 - 62. 124" LINE
 - 63. 126" LINE
 - 64. 128" LINE
 - 65. 130" LINE
 - 66. 132" LINE
 - 67. 134" LINE
 - 68. 136" LINE
 - 69. 138" LINE
 - 70. 140" LINE
 - 71. 142" LINE
 - 72. 144" LINE
 - 73. 146" LINE
 - 74. 148" LINE
 - 75. 150" LINE
 - 76. 152" LINE
 - 77. 154" LINE
 - 78. 156" LINE
 - 79. 158" LINE
 - 80. 160" LINE
 - 81. 162" LINE
 - 82. 164" LINE
 - 83. 166" LINE
 - 84. 168" LINE
 - 85. 170" LINE
 - 86. 172" LINE
 - 87. 174" LINE
 - 88. 176" LINE
 - 89. 178" LINE
 - 90. 180" LINE
 - 91. 182" LINE
 - 92. 184" LINE
 - 93. 186" LINE
 - 94. 188" LINE
 - 95. 190" LINE
 - 96. 192" LINE
 - 97. 194" LINE
 - 98. 196" LINE
 - 99. 198" LINE
 - 100. 200" LINE

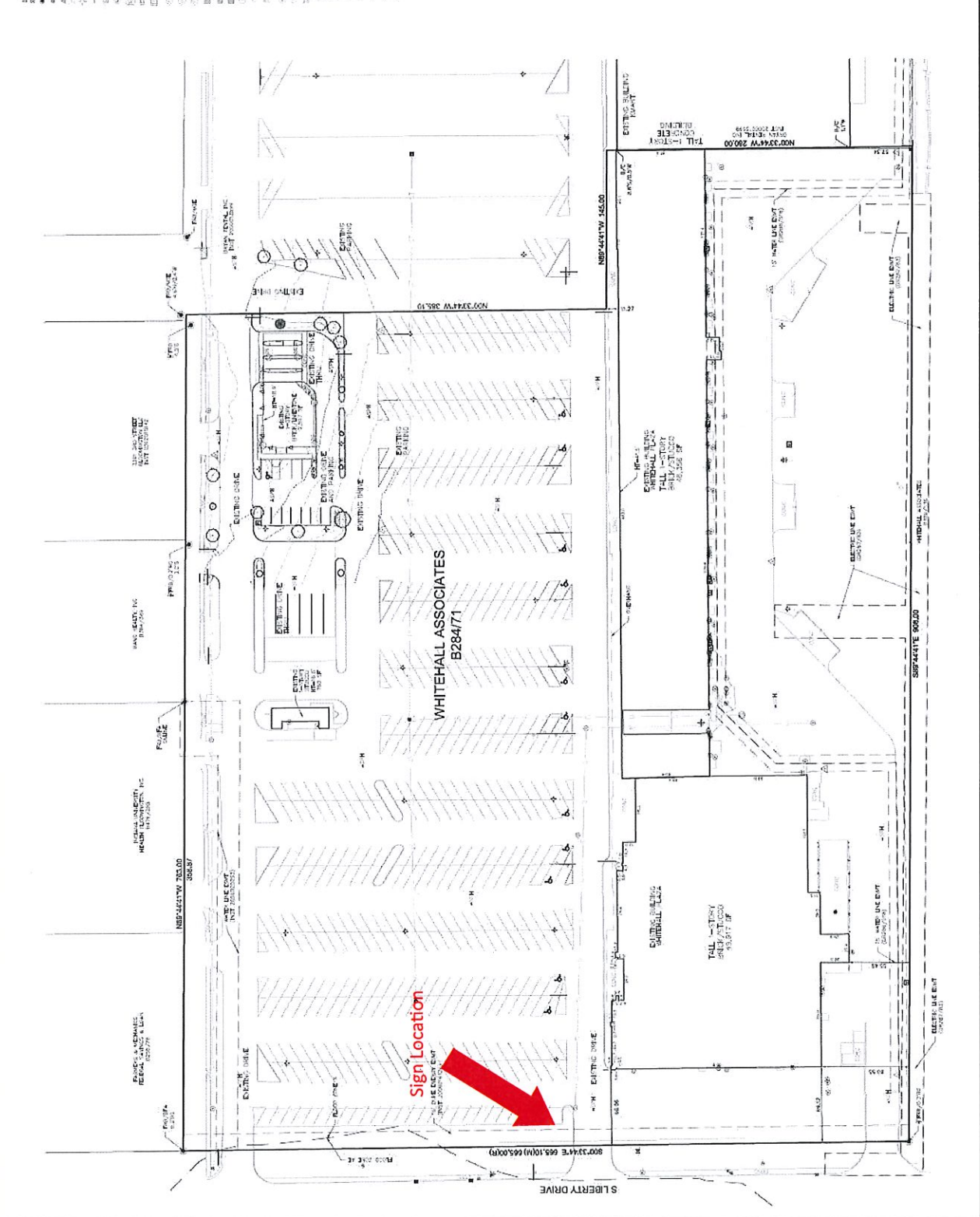

Urbahns Development
Whitehall Plaza
3175 W. 3rd St.
Bloomington, IN 47404

Pole Sign
- w/ 10 Tenant Panels
Scale: ARC 1/4

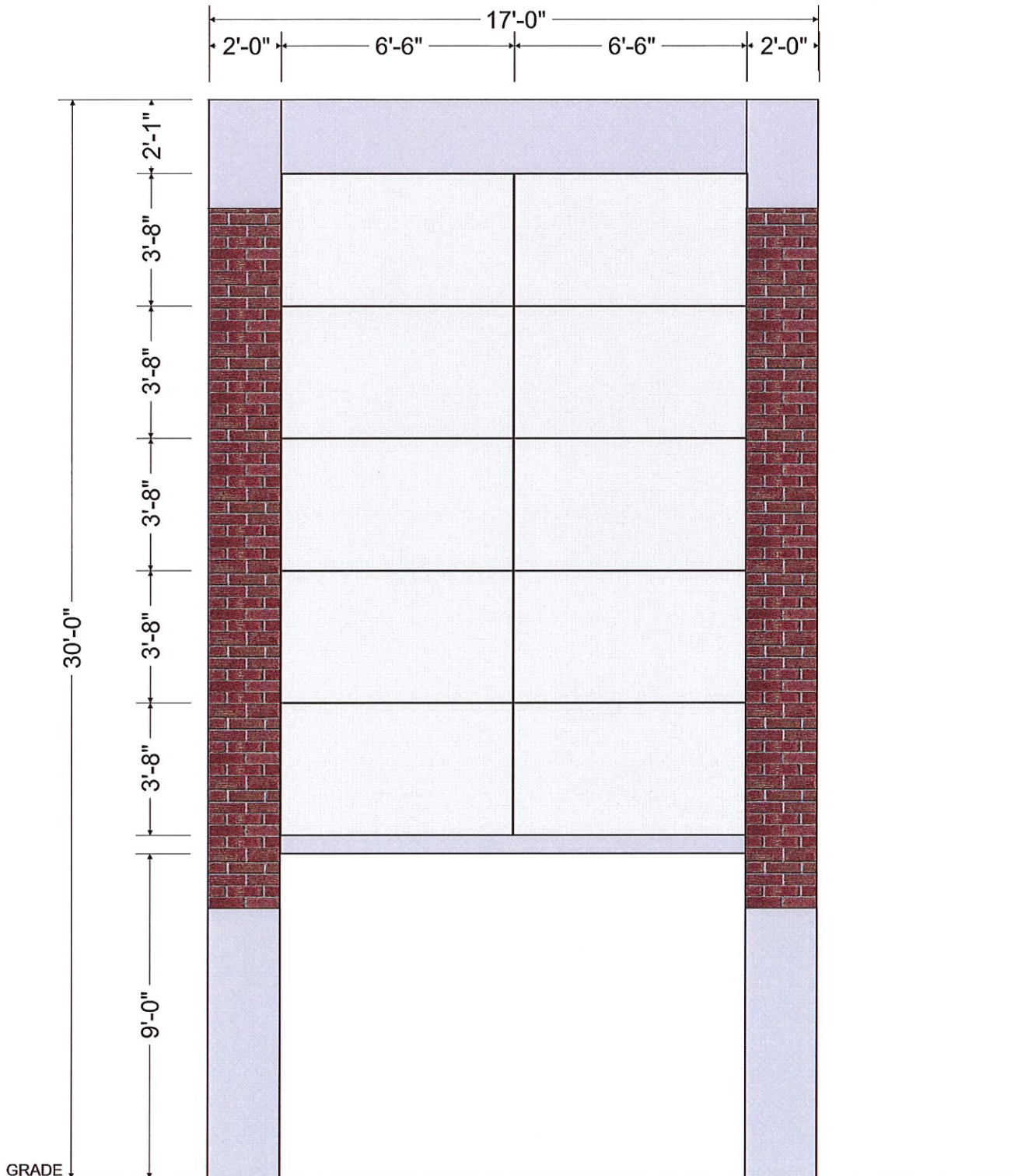



**City of Bloomington
Planning and Transportation Department**

NOTICE OF PERMIT HOLD/DENIAL

2/23/2021
Whitehall Associates
3477 W 3rd Street
Bloomington, IN 47404

To Whom It May Concern:

Your Permit Application #C21-060 for a permanent sign at, 3477 W 3rd Street is being denied for the following reason(s).

- The proposed project violates the terms of the Unified Development Ordinance
- The proposed project requires Approval from the Choose an item.
- The proposed erosion control plan is not in compliance with the terms of the UDO
- Additional information is needed in order to complete plan review
- See attachment or addendum

Comments:

Per the terms of the PUD, allowed signage has already been used.

We cannot approve your application at this time. Please contact the Planning and Transportation Department at (812) 349-3423 with your questions concerning your permit application.

Keegan Gulick
Zoning & Long Range Planner



116 West 6th Street, Suite 200
P.O. Box 2639
Bloomington, Indiana 47402-2639
TEL: 812.332.6556
FAX: 812.331.4511
michael@carminparker.com

February 26, 2021

Board of Zoning and Appeals:

Whitehall Associates appeals the denial of sign permit application No. C21-060 and the approval of application for permanent sign permit No. C20-677.

The sign at issue is a pole sign authorized under the terms of the Planned Unit Development zoning for Whitehall Plaza.

Whitehall Associates is the developer of the Planned Unit Development. In accordance with the PUD approval, four pole signs were permitted and allocated to the development.

Whitehall Associates applied for a permit for a pole sign in accordance with the signs permitted under the PUD. The signage rights were owned by Whitehall Associates.

The City of Bloomington Planning Department Administrator has denied the sign application. The Planning Department appears to have approved a sign permit application, No. C20-677 permitting a pole sign at the Whitehall Plaza area to be installed by a party other than Whitehall Associates, the developer. Whether that permit application can be approved under the current UDO is not a decision for Whitehall Associates. However, it appears that the Planning Department has issued a sign permit to Brian Rentals, Inc. for the fourth pole sign, owned by Whitehall Associates.

The City of Bloomington records establish Whitehall Associates as the developer and owner of the development rights for the Whitehall Plaza PUD. For example, minutes and correspondence pertaining to the PUD approval, variances and amendments to the PUD that have taken place over the last 40 years are attached. These excerpts from public records identify Whitehall Associates as the developer and owner of the PUD. A prior opinion by the City of Bloomington Corporation Council reiterated that the signage rights for the fourth pole sign permitted in the Whitehall Plaza PUD was owned or controlled by the owner of the PUD. Whitehall Associates is the owner of the PUD. Brian Rentals, Inc. is not the owner of the PUD. Brian Rentals, Inc. is a part owner of only one (1) lot in the PUD.

The denial of the sign application submitted by Whitehall Associates is an error. The issuance of the sign permit No. C20-677 to Brian Rentals Inc. is an error. Brian Rentals is an owner of a



February 26, 2021
Page 2

partial interest in one (1) lot of the PUD. The application for a sign permit by Brian Rentals, Inc. was defective and not compliant. The permit should not have been issued to Brian Rentals, Inc.

Whitehall Associates requests that the Planning Department be directed to issue the sign permit to Whitehall Associates permit No. C21-060.

Very truly yours,

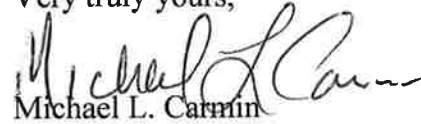

Michael L. Carmin

MLC/nem
Enclosures

Cc: Bryan Rentals, Inc.
3175 W. 3rd Street
Bloomington, IN

426714



Index of Documents

1. Corporation counsel email acknowledging Whitehall Associates' consent required
2. Whitehall Associates/Developer letter for PUD development
3. Whitehall Associates/Developer letter for PUD development
4. Minutes of Plan Commission meeting, January 8, 1980

PCD-60-79 recognizes Whitehall Associates as the developer of the PUD. Development standards and requirements to be imposed as part of the approval are reviewed and discussed with and accepted by Whitehall Associates. The Minutes demonstrate that Whitehall Associates was the party responsible for and in control of the components of the development in the PUD.

5. Board of Zoning Appeals Minutes, June 26, 1980

Minutes demonstrate that Planning Staff recognized that the developer controlled the pole signs. Staff states: The Staff is not opposed to the use of the permitted pole signs by individual tenants where this is within the scope of the developer's overall signage plans.

6. Application for Permanent Sign Permit C20-677
7. Notice to permit holder – denial of permit application C21-060
8. June 6, 1980 letter from Geoffrey Grodner

The Petitioner for the sign variance to allow use of one pole sign on what became the K-Mart property and is now the property owned by Bryan Rentals, Inc. and Crane, LLC, includes acknowledgment that the variance petitioner obtained consent from Whitehall Associates, as the developer, to the use of the pole sign on that property.

9. Warranty Deed to Bryan Rental, Inc. and Crane, LLC.

Deed demonstrates that Bryan Rental, Inc. is not the sole owner of the property identified in Sign Permit issued to Brian Rentals, Inc. Co-owner of the subject property did not join in the application for the sign permit.



Eric Greulich <greulice@bloomington.in.gov>

Fwd: Sign at former K-Mart location

1 message

Philippa Guthrie <guthrie@bloomington.in.gov>
To: Jacqueline Scanlan <scanlanj@bloomington.in.gov>, Eric Greulich <greulice@bloomington.in.gov>

Mon, Dec 17, 2018 at 4:20 PM

FYI

	<p>Philippa M. Guthrie Corporation Counsel, Legal Department City of Bloomington, IN guthrie@bloomington.in.gov 812.348.3547 Office 812.326.7512 Cell philippa@bloomington.in.gov</p>
---	---

CONFIDENTIALITY NOTICE

This transmission (including any attachments) may contain information which is confidential, attorney work product and/or subject to the attorney-client privilege, and is intended solely for the recipient(s) named above. If you are not a named recipient, any interception, copying, distribution, disclosure or use of this transmission or any information contained in it is strictly prohibited, and may be subject to criminal and civil penalties. If you have received this transmission in error, please immediately call us collect at (812) 348-3428, delete the transmission from all forms of electronic or other storage, and destroy all hard copies. Do NOT forward this transmission. Thank you.

----- Forwarded message -----
From: Philippa Guthrie <guthrie@bloomington.in.gov>
Date: Mon, Dec 17, 2018 at 4:20 PM
Subject: Re: Sign at former K-Mart location
To: Andrew Sheff <Andrew@shefflegal.com>

Hi, Andy. Here is our determination:

- The Kmart property and the property to the west were approved as one zoning lot under the Planned Unit Development approval. The overall development is regulated by the PUD, approved variances, and the current UDO regulations for multi-tenant signage (because of how signage was addressed in the PUD).
- Staff has determined that the variance that was granted for Kmart allows for the existing pole sign to be torn down and rebuilt to the same specifications as the original pole sign at 300 sq. feet maximum on each side, and the height can be 35' as measured from the crown of the roadway. It also appears that the pole sign is on the property of "Monroe County Pizza" and would therefore need to be relocated a few feet south.
- We will want some evidence, e.g. a survey, demonstrating what the height of the crown of the roadway is.
- Under both the old UDO and the current UDO, this PUD was allowed 4 signs in total. The variance for the Farmers and Mechanics pole sign was based on this limit of 4 multi-tenant signs and the pole sign used one of those allotted signs. The variance for Kmart also used that justification for the pole sign—it is clear in the documentation. So out of the 4 allotted signs for the PUD, 3 of those have already been placed, counting the F&M and KMart pole signs, and the large sign on 3rd Street. Staff would agree to an additional free-standing sign on 3rd St that is 125 square feet per side and 15 feet tall measured from the crown of the roadway. Again, we will need evidence of the height of the crown of the roadway. Mr. Kamen's tenant is restricted to a single 36 square foot sign on that multi-tenant sign. The placement of this 4th sign would use the remaining allowance for the entire development, and we would therefore require a letter of approval from the other owner of the PUD for this 4th sign.

Thanks for your patience as we worked through this.

	<p>Philippa M. Guthrie Corporation Counsel, Legal Department City of Bloomington, IN guthrie@bloomington.in.gov 812.348.3547 Office 812.326.7512 Cell philippa@bloomington.in.gov</p>
---	---

CONFIDENTIALITY NOTICE

This transmission (including any attachments) may contain information which is confidential, attorney work product and/or subject to the attorney-client privilege, and is intended solely for the recipient(s) named above. If you are not a named recipient, any interception, copying, distribution, disclosure or use of this transmission or any information contained in it is strictly prohibited, and may be subject to criminal and civil penalties. If you have received this transmission in error, please immediately call us collect at (812) 348-3428, delete the transmission from all forms of electronic or other storage, and destroy all hard copies. Do NOT forward this transmission. Thank you.

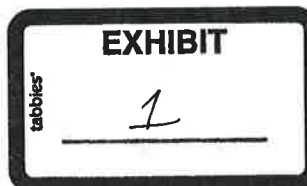

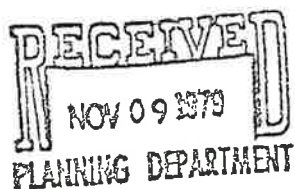

211 North Delaware Street
 Indianapolis, Indiana 46204
 November 9, 1979

Mr. Tim Mueller
 Department of Planning & Zoning
 City of Bloomington
 Bloomington, Indiana 47401

RE: Whitehall Associates - Southwest Corner
 of S.R. 37 Bypass and Whitehall Pike.

Dear Tim,

In response to our recent meetings concerning our proposed development plan for the referenced 82 acre site, please accept this letter as the written statement of Whitehall Associates as to our current development plan for the proposed site.

In keeping with our prior conversation concerning the phase type development for the 30 acre parcel located on the immediate corner, we consider the first phase of that development to be the existing free-standing location for Farmers and Mechanics Savings & Loan Association which was developed during calendar year 1977. That site consists of approximately 1½ acres which is currently owned in fee simple by Farmers and Mechanics Savings & Loan Association.

As a second phase of the overall development, we intend to construct a K Mart department store consisting of approximately 72,879 square feet plus two free-standing buildings all of which shall be located at the immediate interchange of S.R. 48 and S.R. 37 Bypass and located on approximately 15 acres of the aforementioned 30 acres. We hope to commence construction of the K Mart facility this fall with an expected opening of late summer, 1980. Construction of the two free-standing buildings will not be commenced until the spring of 1980 and completed approximately six months thereafter. As part of that development, we intend to provide island type landscaping in the K Mart parking lot with a rather elaborate landscape plan for each of the free-standing buildings. Our storm water run off will be carried in a southeasterly direction and will be accomplished by a series of catch basins located in the K Mart parking lot. All surface water run off from that development will ultimately be channeled under the railroad tracks toward the S.R. 37 Bypass. Access to the shopping center will be accomplished by construction of a right-in/right-out curb cut approximately 425 feet west of the interchange with a full curb cut approximately 825 feet west of the interchange. In order to facilitate traffic movement, we propose to complete one additional acceleration/deceleration lane between the location of Farmers and Mechanics Savings & Loan and the proposed right-in/right-out lane.

EXHIBIT

tabbles
 2

Mr. Tim Mueller
Department of Planning & Zoning

November 9, 1979
Page Two

The third and fourth phases of the proposed development will consist of one outlot located west of the main entrance of the shopping center as well as development of approximately 80,000 square feet of additional retail space. Construction of the third and fourth phases is planned for commencement in the spring of 1980 with completion in the fall of 1980.

Storm drainage from the fourth phase, namely the free-standing building will be carried into the drainage swale located in the southern right-of-way for Whitehall Pike with the shopping center parking lot for Phase 3 drained by catch basins. Water from the third phase will be retained on the southeast portion of the overall 82 acre tract by use of a storm water retention basin. The intent of the developer is to contain its own storm water and to release that water through a storm pipe at the southeast corner of its property. The overall drainage plan for the entire shopping complex will serve to reduce the amount of storm water drainage running to the southwest by diverting the natural pattern of the west half of the shopping center from the southwest to the southeast.

Phase 5 of the development, namely two additional free-standing buildings located to the west of the free-standing facility known as Phase 4, will be developed at a later time most likely calendar years 1981 and 1982.

As far as the remaining acreage is concerned, the developer has no current plans for its immediate development but wishes to express its desire to work with the City of Bloomington in obtaining an urban development action grant or other similar type financing such that it may be developed into an industrial or commercial park.

Sincerely,

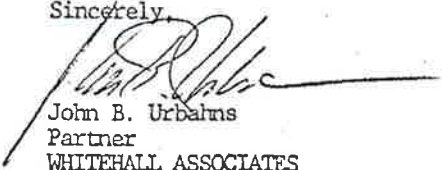
John B. Urbahns
Partner
WHITEHALL ASSOCIATES

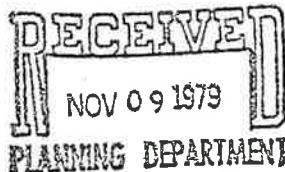

/csf

JOHN B. URBAHNS
 ATTORNEY-AT-LAW
 211 NORTH DELAWARE
 INDIANAPOLIS, INDIANA 46204
 317-639-1833

December 27, 1979

Mr. Tim Mueller
 Director
 City Planning
 Bloomington, Indiana 47401

RE: Development by Whitehall Associates -
 Southwest Corner of S.R. 48 and S.R.37
 By-Pass.

Dear Mr. Mueller:

At your request, please accept the following as a descriptive outline of the phasing Whitehall Associates intends to use in development of its 82-acre tract located on the southwest corner of the above referenced interchange. In addition, we will accompany reference to each phase of development with a corresponding statement concerning roadway and drainage improvements and the coordination of those improvements with each phase as shown on the attached site plan.

- 1) We consider Phase I of our development to be a free-standing Farmers and Mechanics Savings & Loan already existing and located on approximately 1.2 acres of real estate located at the southeast corner of Whitehall Pike and Drive "C" as shown on the attached site plan. This development was undertaken in 1977 and is a completed improvement except for the fact that sidewalks will be added along the southern boundary of said parcel in coordination with Phase IV development of the adjacent pad sites. No additional roadway or drainage improvements are contemplated as a result of Phase I.
- 2) Phase II of our development consists of a free-standing 72,897 square foot K Mart facility located on the immediate southwest portion of the referenced interchange and in connection with that development we propose to construct Drive "A" and Drive "B", Drive "A" to include a completed deceleration lane and acceleration lane. Drive "B" will be a right-in/right-out cut planned for connection to the already widened S.R. 48 with a further provision that those immediate areas of S.R. 48 connecting with the curb cut be re-surfaced upon completion. In addition, we propose to re-surface the north side of S.R. 48 in such a manner as to have two full width 12-foot lanes to a point approximately 50 feet west of Drive "A". Our intention is to use the

EXHIBIT

tabbles

3

Mr. Tim Mueller

December 27, 1979

Page Two

southern lane of those two lanes for left turning movements and the northern lane for through traffic. The northern 12-foot lane already exists but would require an additional inch of topping material in order to satisfy the intent of two 12-foot lanes. In summation, we propose to build in connection with Phase II, Drive "A" and Drive "B" with appropriate acceleration and deceleration lanes as well as additional improvements on the north side of S.R. 48 for purposes of providing left turn movements. As indicated, those street improvements would be made in accordance and in connection with our plans for the K Mart facility. Concerning storm water drainage, we propose to construct a drainage basin on the immediate southeast portion of the overall 82-acre tract for storm water retention and detention and intend to construct that basin in a sufficient size to handle storm water drainage from Phase II and Phase III C as shown per the attached.

- 3) Phase III A and Phase III B will be developed simultaneously with or immediately after construction of Phase II and will consist of a free-standing restaurant or financial institution, however, additional proposed uses shall include all other free-standing retail uses such as a paint and wall paper store, tire and battery store or other comparables. No additional improvements to S.R.48 will be made as a result of Phase III A or B. Storm water drainage of those two phases will be accomplished by taking surface water run off into the existing drainage swale located on the southern portion of S.R. 48.
- 4) Phase III C of our development will consist of a supermarket and other retail shops and will have approximately 75,000 gross square feet. Phase III C will be connected to Phase II by use of a party wall and will be constructed immediately after Phase II. Proposed retail uses for Phase III C shall include a supermarket and drug store, plus all other conventional retailers such as a hardware store, music store, barber shop, dry cleaning and laundry pick up, fabric shop, florist, gift shop, hobby shop, pet shop and other comparable tenants. In connection with development of Phase III C, we propose to extend the existing Drive "C" as constructed to the southern point of the Phase III C development. Storm water drainage for Phase III C will be accomplished by a storm pipe running in a southeasterly direction and connecting with the to-be-constructed retention/detention basin constructed as part of Phase II. No additional improvements to S.R.48 would be undertaken as part of Phase III C.

Mr. Tim Mueller

December 27, 1979

Page Three

- 5) Phase 3D will consist of three free-standing pad site developments none of which to be undertaken until commencement of Phase III C. All pad sites will have access off the parking lot constructed in connection with Phase III C and upon their development would carry the proposed sidewalk for Phase I in a complete easterly direction to the point of connection with Phases III A and III B. Phase III A will also have a sidewalk located on its southern boundary line and will be connected with a sidewalk to be constructed through the parking lot on Phase II. No additional improvements to S.R. 48 will be constructed as the result of Phase 3D development. Anticipated uses in Phase 3D would likely be free-standing restaurants, financial institutions, or other retail and service businesses. All buildings constructed on S.R. 48 will be fully improved with four sides of brick or stone and will have totally contained trash pick up areas.
- 6) Phase IV is currently an unplanned phase of the overall development, however, it is the intention of the developer to develop recreational or commercial uses comparable to those contained in Phase III C of the shopping center or entertainment functions consisting of possible bowling alley, handball court, movie theater, or other comparable uses. No additional roadway improvements would be required during this phase due to the fact that Drive "C" will be extended as part of the development of Phase III C. All drainage in Phase IV shall be carried in a generally southerly direction to retention/detention basin to be located on the far southwest corner of the overall 82-acre tract.
- 7) Phase V, or the balance of the 82 acres, will be developed into a light industrial area consisting of high quality free-standing buildings and will specifically exclude heavy industrial uses, housing or further commercial development. Proposed uses for the light industrial area would include assembly operations for pre-manufactured parts or assemblies of components or its comparables. Such uses might also include assembly, repair and/or manufacturing of light component parts or products; manufacture of soft drink beverages and its bottling; manufacture of office machinery, electrical and mechanical; manufacture of light, portable household appliances and/or related electrical tools and components; manufacturing of jewelry and leather products, manufacturing of pharmaceutical, biological, medical and cosmetic goods; manufacturing of optical goods, recording instruments,

Mr. Tim Mueller

December 27, 1979
Page Four

phonograph records and/or distribution of operations with warehousing facilities. In connection with the development of the light industrial park, the roadway extended as part of Phase III C shall be completed with a connection to Curry Pike. Construction of the Curry Pike connection shall include a passing blister on the west side of Curry Pike. All drainage for the light industrial area shall in large be contained in a storm drainage basin located at the southwest corner of the 82 acre property with approximately 25% of the light industrial area, namely that area located immediately south of Phase III C being drained to the catch basin constructed as part of Phase II and located at the southeast portion of the 82 acre tract.

The attached drawing and site plan is the latest and most complete drawing of all intended development for the property owned by Whitehall Associates. Should you have any questions concerning this development or the explanations herein contained, kindly contact the undersigned.

Sincerely,



John B. Urbahns
Attorney-at-Law

/csf
Encl.

**PCD-60-79 - WHITEHALL ASSOCIATES, southwest corner of Whitehall Pike and the Highway 37 Bypass, request for overall plan outline and development plan approval for the K-Mart. Mr. Mueller gave the staff report. He explained the surrounding zoning and the layout of the proposed planned development for Whitehall. Phase 2, the K-Mart, is to be the first one built, followed by Phase 3A and 3B (2 front lots), then by Phase 3C and 3D. Phase 4, 8.2 acres of retail or commercial recreational site, Phase 5, 38 acres of light industrial subdivision are to be flexible in terms of timing. The major point of concern has been the traffic improvements to Whitehall. He went into detail on the improvements to Whitehall, using a drawing: pointing out entrances and new lanes. There will be two full lanes plus left turn lane at the main K-Mart entrance. Another entrance to the east will have right turns in and out only, controlled by the existing median barrier. With phase 3C, the existing west entrance will be extended into the center. A westbound left turn lane will be provided in addition to the two westbound lanes now there. With phase 5, the street access to Curry Pike will be developed, with a new left turn lane on Curry. The developers have agreed to accept this scheme as of 1/8/80. The State's comment on the easterly entrance on (December 27th) was to ask if the City could deny that entrance. The Staff had expressed no objection up to this point, but had expressed the need for the State's input on this. The State's position is that it is only 400' from the Bypass, where they are studying a grade separation. They are studying this feature and will not have the answers for a while. They feel that this driveway will interfere with some of their alternatives, but they are not inclined to deny it on their own authority. The staff report lists some alternatives, recommending elimination of all but right turns in and require that Phase 3B follow 3A and 3D to give the State more time to study the intersection. However, the developers have indicated that this would not be negotiable to K-Mart.

PCD-60-79
APPROVED

Mr. Mueller discussed drainage, landscaping, and sidewalks.

He stated the staff recommends approval with the following conditions:

For Outline Plan:

1. Commission's decision on East driveway (if odds with applicant's request).
2. Asphalt overlay at main entrance as per staff exhibit (west of drive to west end of existing median island, both sides of street).
3. West drive to have westbound left turn lane in addition to the two existing westbound lanes, as per staff exhibit or any other configuration required by the State Highway Commission.

EXHIBIT

4

tabbies

Plan Commission Meeting, January 8, 1980

14

4. Sidewalks on south side of outlots to be part of Phase 3C. Sidewalk configuration on Phase 3B to be determined at development plan approval for 3B.
5. Plans submitted on January 4, 1980, govern in instances of conflict with John Urbahns' letter of December 27, 1979.
6. Construction of Phase 2 is to be assured before permits for Phases 3A and 3B. Construction of Phase 3C is to be assured before permits for Phase 3D.
7. Geoffrey Grodner's letter of January 7, 1980, to be incorporated in approval with the change suggested by Steve Ferguson on drainage: Whitehall Assoc. agrees to leave to City discretion the size of the drainage retention basin for future phases in accordance with applicable City storm drainage retention standards, in effect at the time of application for the building permits or if there is no established standard, then as the City shall in its discretion determine.
8. Dedication of 50' from Whitehall centerline.
9. 50' setback from r.o.w. on Phase 3B.

For Development plan - Phase 2

1. Landscaping plan to be revised as per staff letter of January 8, 1980.
2. State Highway Commission approval of Phase 2 Whitehall changes.
3. Conditioned on Council approval of revised outline plan.

Mr. Zabriskie stated he was afraid there would be a big bottleneck after coming through the intersection going west where the road comes down to one lane for that short distance. He stated cars go through that intersection at high speeds. He asked if there was enough r.o.w. there to make 2 lanes all the way.

Mr. Mueller stated this project did not do anything to affect this bottleneck that already exists.

Mr. Zabriskie stated he thought someone should go ahead and make the north side 2 lanes all the way instead of leaving 400' in one lane.

Mr. Mueller stated that the State controls the highway.

Geoffrey Grodner, Attorney representing Whitehall, stated they believe they have resolved all the problems and agree with the conditions stated by the staff, the State, and the developer.

Plan Commission Meeting, January 8, 1980

15

He stated the only remaining concern for the Commission is the eastern most entrance. He stated that since Mr. Mueller had written the 3 alternatives the developer and the staff have met and agreed K-Mart will not build without this entrance. He stated that Phase 3A and 3B must be developed in the near future after the K-Mart store to allow the developer to pay for the great amount of road improvements and parking that will be done as part of Phase 2 (K-Mart).

Mr. Steve Ferguson stated that Cook is very concerned about the drainage for Phase 4 and Phase 5 that are to be developed at a later time. He would like something committed at this point on what they intend to do with the drainage at that time. They feel that the standard that should be required for this area should be higher than the 10-year storm.

Mr. Grodner stated that they are in agreement with Mr. Ferguson's comments to the extent that they believe the drainage plans for Phase 4 and 5 should be discussed at the time of development plan approval for those phases. He feels that they might have disagreement on what standard should be applied. He did indicate that they have made changes in the Phase 3 to accommodate Cook - they are diverting all the drainage away from Cook and into the Twin Lakes watershed.

Mr. Ferguson stated that it is a much improved plan over what proposed back a few years ago.

Mr. Dro asked Mr. Ferguson where the water goes from the Cook watershed.

Mr. Ferguson stated that after crossing Gifford Road the water goes underground.

Mr. Zabriskie asked if the developer and Mr. Ferguson all agreed with the conditions stated.

Both indicated they did.

Mr. Zabriskie moved to approve PCD-60-79 outline plan and development plan for Phase II with the following conditions:

(Please see outline plan and development plan for Phase II with conditions on the previous 2 pages of this case.)

Mr. Irie seconded.

Mr. Grodner asked what the Commission decided about the east entrance.

Ms. Wilson stated she had not heard any comment about this. She realized this is mandatory for K-Mart to build.

Plan Commission Meeting, January 8, 1980

16

*Mr. Zabriskie stated he would include in his motion to approve the east driveway with a right-turn-in and right-turn-out lane.

Mr. Grodner also wanted to clarify that the 50' setback for Phase 3B runs from the existing right-of-way and not any increased r.o.w. which may occur as a result of dedication by the developer.

Mr. Mueller stated that one thing has been agreed to by all but is not on the plans yet. This is a little island to channelize the right turns out of the easterly entrance.

Mr. Urbahns stated that they did agree to provide it.

*Vote was taken. Motion passed unanimously.

**Z0-70-79 RUSSELL DUNCAN, east side of 3300 block of South Rogers, request for change of zone from RS to BA. Mr. Klotz gave the staff report. He pointed out the problems of rezoning this to BA in a residential zone -- BA would allow many commercial uses that would not be appropriate for this location. Staff recommended the Commission forward a denial to the Council.

Z0-70-79
DENIED

Mr. Ed McCrea, Attorney for petitioner, stated the son, Roger Duncan, would like to sell a few used cars from this location and then take care of the existing trailer park. He pointed out that there are businesses to the north of Country Club Road and a few businesses south of Country Club Road. They would agree to a condition of zoning or to a separate agreement to prevent another use from going in there later. Since it is so small there should not be a threat of any other kind of business wanting to go in there. He has not heard of any opposition from the neighbors. They don't feel it would have any negative impact on the area to sell a few used cars at this location.

Discussion ensued.

Mr. Mueller stated they could not make a condition of zoning or have a separate agreement -- contract zoning is not enforceable. He explained what spot zoning is.

Mr. Dro asked what zoning is for a mobile home park.

Mr. Mueller stated it should be in a multi-family district. There are many scattered around the City in RS zones -- these are pre-existing non-conforming, such as this one of Mr. Duncan's.

*Mr. Irie moved to deny Z0-70-79. Mrs. Pryor seconded. Motion passed unanimously.

**PCD-2-79 JERRY GATES, southeast corner of East 10th Street and Highway 46 Bypass, request for a change of zone and PCD designation. Mr. Mueller stated that this one item has been carried the whole year and that the petitioner has never returned to place it on the agenda. We were asked to table this before the preliminary hearing. The staff suggested that this be dropped from the docket until further notice. Mr. Gates would have to

PCD-2-79
REMOVED FROM
DOCKET

Mr. Mueller stated that he wanted to qualify that approval by the Board does not relieve Goodrich of access control obligations for decel lane construction. That will be worked out to the satisfaction of the City Engineer.

- *** Ms. Pryor amended her motion to the effect that Goodrich is not relieved of access control obligations, Mr. Sturbaum seconded, motion passed unanimously.
- ** Mr. Wise moved for a 5 minute recess, Ms. Pryor seconded, motion passed unanimously.

HO-39-80 JACK D. CASSIDY
916 Park Ridge Court
Request for special exception permit to operate a home occupation
(woodburning stoves, telephone sales)

CONTINUED

- *** Mr. Cunningham made a motion that HO-39-80 be continued since the petitioner was not present. Ms. Wilson seconded, motion passed unanimously.

V-40-80 WAREHOUSE FURNITURE
1320 North College
Request for variance from signage and setback requirements.

APPROVED
as per
staff
modificati

Mr. Klotz presented the petition for V-40-80, Warehouse Furniture proposal to convert an existing changeable letter portable sign into a permanent, fixed base, ground type sign. The minimum required setback for this type of sign is one-half of that required for a building, or 15' in the BG zone. Zoning and land uses were presented.

The staff recommended approval with the modification that the sign shall be located north of, and directly adjoining; the private sidewalk on the north (17th Street) side of the building.

Ms. Richmond asked if there was anyone to speak in favor of this petition.

Dan Slusz, owner, spoke in favor of the petition. He stated that the sign would help to identify the business, and to help distinguish Warehouse Furniture from Warehouse Carpet. The sign will also help with identification since advertising costs are always going up.

- *** Ms. Pryor made a motion that V-40-80 be approved as per staff modifications, Mr. Cunningham seconded, motion passed unanimously.

V-42-80 WALDORF ASSOCIATES/ALIG ASSOCIATES
Whitehall Plaza
Request for variance from signage requirements.

APPROVED

Mr. Klotz presented the petition for Waldorf Associates, proposal for a very substantial (565 sq. ft.) individual pole sign for K-Mart as an element of the overall signage package for Whitehall Plaza PCD. Based on the proposed future size of the PCD, four pole signs of up to 300 sq. ft. total area each would be permitted. One pole sign has already been erected in the PCD. Based on the proposed future size of the PCD, Farmers and Mechanics Savings and Loan Association, with the question of individual tenant use of the permitted pole signs being considered by the Board as V-25-75. This requested sign would be the

EXHIBIT

5

~~second of the permitted pole signs to be erected for the PCD with a third to follow as a center identification sign that would include identification of some of the major tenants (other than K-Mart and Farmers and Mechanics). Use of the fourth permitted sign is undecided at this time.~~

He explained that as a policy, the staff is not opposed to the use of the permitted pole signs by individual tenants where this is within the scope of the developer's overall signage plans. However, it is the staff's feeling that all attempts should be made to keep the size of individual tenant pole signs within the 300 sq. ft. maximum. If a facility that is a tenant of PCD in this instance was a free standing operation, then that facility would be permitted only 144 sq. ft. (72 sq. ft. per side) of total pole signage. An overall center identification sign, with opportunities for smaller scale identification of individual major tenants, would be far more appropriate for size variance consideration than is an individual tenant sign.

Zoning and land uses were presented.

The staff recommended approval of the individual tenant pole sign for K-Mart but recommended denial of the size request variance. The staff would support and recommend approval of an individual tenant pole sign for K-Mart at this location if it were restricted to approximately 300 square feet in size to conform to planned commercial development regulations.

Ms. Richmond asked if there was anyone to speak in favor of this petition.

Mr. Geoffrey Grodner spoke in favor of Waldorf Associates (distinct from Whitehall Associates). He stated that there is, between the property line of Whitehall Associates (K-Mart property line) and the 37 Bypass a utility easement of 100 feet. Beyond that there is a very heavy tree line. He stated that there will be substantial screening of the K-Mart store from the 37 Bypass especially during the vegetation season. He stated that K-Mart originally came to the department with a request for a 50' high sign (standard K-Mart sign). The staff informed them that there is a 35' limitation, therefore the sign has been revised down. In order to do that and still obtain adequate visibility of the sign from the 37 Bypass they have proposed the standard K-Mart sign. He stated that they desire for the sign to face east and west rather than just north. He went on to say that only one other sign is now being planned for the shopping center (Whitehall Plaza) listing the stores. K-Mart, he said is the anchor store.

Ms. Richmond asked if there was anyone else to speak in favor of this petition. There was no one.

Ms. Richmond asked if there was anyone to speak in opposition to this petition. There was no one.

Ms. Richmond asked if Members of the Board had questions.

Mr. Sturbaum stated that the ordinance says that the sign can be 35' above grade (above the centerline of the highway). He stated that he thinks the lane is higher than the bypass.

Bob Neely of Waldorf Associates was present and explained the grading on the site. Their question was where do they establish the 35' from the center of the highway. He stated that they would be glad to abide by whatever point the staff requested that they use.



CITY OF BLOOMINGTON
Planning and Transportation Department
401 N. Morton St., Bloomington, Indiana 47404



Phone: 812-349-3423

Fax: 812-349-3520

Email: planning@bloomington.in.gov

APPLICATION FOR PERMANENT SIGN PERMIT

*** MAKE CHECKS PAYABLE TO THE CITY OF BLOOMINGTON**

Date Applied: 11/25/20
 Name of Business: Brian Rentals, Inc.
 Type of Business Use: Commercial
 Address of Business: 3175 W. 3rd St.
 Business Phone: _____
 Alternative Phone/Fax: _____
 Name of Applicant: Hi-Rise & Sign Services
 Applicant Phone: 317-546-1111

<small>(OFFICE USE ONLY)</small>	
Application #:	<u>C20-677</u>
Permit Fee:	<u>\$125.00 per sign</u>
Total Fee:	<u>WAIVED</u>
Date Issued:	<u>2/9/2021</u>
Permit Reviewer:	<u>Keegan Gulick</u>

A SCALED SITE PLAN IS REQUIRED WITH YOUR APPLICATION.

In order to receive a **permanent sign permit**, the applicant shall submit a site plan containing the following elements:

1. Scale and North arrow;
2. Location of building(s), driveway(s), and parking area(s);
3. Location and size (in square feet) of all existing sign(s);
4. Indicate type of existing sign(s): wall, pole, or ground signage;
5. Location and dimensions of proposed sign(s);
6. Distance between building and proposed sign location(s);
7. Name and location of adjacent street frontage(s), if applicable; and
8. Distance between curb edge and sign location.

CERTIFICATION

I am the owner or authorized agent responsible for compliance, and hereby acknowledge the following:

1. I have read this application and all related documentation and I represent that the information furnished is correct.
2. I agree to comply with all City ordinances and State statutes, which regulate construction, land use, and occupancy.
3. Any changes made to sign dimensions or location shall be submitted to the City of Bloomington for review.
4. If any misrepresentation is made in this application, the City may revoke any Certificate issued based upon this misinformation.
5. No sign installation is allowed until a permit has been issued by the Planning and Transportation Department.

Applicant's Signature _____

Date _____

If you have questions about sign ordinance requirements, please call the **Bloomington Planning and Transportation Department @ 812-349-3423.**





**City of Bloomington
Planning and Transportation Department**

NOTICE OF PERMIT HOLD/DENIAL

2/23/2021

Whitehall Associates
3477 W 3rd Street
Bloomington, IN 47404

To Whom It May Concern:

Your Permit Application #C21-060 for a permanent sign at, 3477 W 3rd Street is being denied for the following reason(s).

- The proposed project violates the terms of the Unified Development Ordinance
- The proposed project requires Approval from the Choose an item.
- The proposed erosion control plan is not in compliance with the terms of the UDO
- Additional information is needed in order to complete plan review
- See attachment or addendum

Comments:

Per the terms of the PUD, allowed signage has already been used.

We cannot approve your application at this time. Please contact the Planning and Transportation Department at (812) 349-3423 with your questions concerning your permit application.

Keegan Gulick
Zoning & Long Range Planner



ATTORNEYS AT LAW

ROGERS, McDONALD AND GRODNER

DAVID ROGERS
 THOMAS M. McDONALD
 GEOFFREY M. GRODNER
 SCOTT E. FORE
 MARC R. KELLAMS

P. O. BOX 279
 WORKINGMENS FEDERAL BUILDING
 BLOOMINGTON, INDIANA 47402
 812/332-4431

June 6, 1980

Board of Zoning Appeals
 City of Bloomington
 P. O. Box 100
 Bloomington, IN 47402

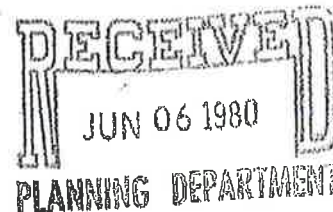

RE: Waldorf Associates
 Sign Variance

Dear Board Members:

Waldorf Associates has submitted its application for approval of a variance to permit the erection of a sign for the K-Mart Department Store being constructed in Whitehall Plaza on Whitehall Pike. The variance requested is from the provisions for signs for Planned Commercial Developments which require all signs to bear the name of the development only and which limit the signs to a total of 300 square feet each.

Whitehall Associates, the developers of Whitehall Plaza, have agreed to permit Waldorf Associates to utilize one sign for the K-Mart Store which would ordinarily be used only for the full development. Therefore, this request will not result in a greater number of signs at Whitehall Plaza than permitted by ordinance.

Waldorf Associates is also requesting a variance from the 300 square foot limitation so that the sign, as shown on the enclosed plans, may have surfaces of approximately 282.5 feet facing both east and west. While the ordinance does not specifically state that total sign surface shall include both sides of the sign, your staff has so interpreted the ordinance. In requesting this variance, Waldorf Associates considered designing a smaller but taller sign, but concluded that the plan submitted is most consistent with the City's Sign Ordinance.

Very truly yours,

ROGERS, McDONALD & GRODNER

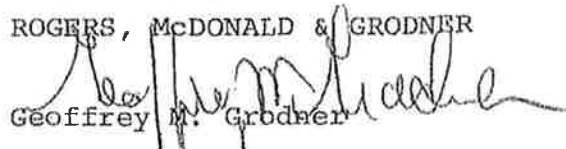
 Geoffrey M. Grodner

GMG:NR



V-42-80

PETITIONERS STATEMENT

Jim Fielder
Monroe County Recorder IN
IN 2000012081 WAR
08/01/2000 14:25:55 7 PGS
Filing Fee: \$28.00

**LIMITED WARRANTY DEED
(BUILDING)**

This Instrument is being re-recorded to reflect

Treasurer's stamp

WITNESSETH:

Jim Fielder
Monroe County Recorder IN
IN 2000013598 RERE
08/11/2000 11:40:52 7 PGS
Filing Fee: \$29.00

THIS DEED, made effective as of the 27th day of July, 2000, by and

between GLIMCHER HOLDINGS LIMITED PARTNERSHIP, A Delaware limited partnership having an address c/o Glimcher Properties Limited Partnership, 20 South Third Street, Columbus, Ohio 43215 (hereinafter referred to as "**Grantor**"), and Tenants in Common, BRYAN RENTAL, INC. (with a 2/3 undivided interest) and CRANE, LLC (with a 1/3 undivided interest) having a mailing address c/o Bryan Rental, Inc., at 2356 Industrial Drive, Bloomington, Indiana 47404 (hereinafter referred to as "**Grantee**").

017-05250 03

WITNESSETH:

That Grantor for and in consideration of the sum of TEN and NO/100 (\$10.00) DOLLARS and other good and valuable consideration to it in hand paid by Grantee, the receipt whereof is hereby acknowledged, has quitclaimed, given, granted, bargained, sold and conveyed and by these presents does quitclaim, give, grant, bargain, sell, convey and confirm unto the Grantee, its successors and assigns, without warranty, all of Grantor's right, title and interest, if any, in and to all those certain buildings, structures, footings, foundations, fixtures, equipment, columns, piles, improvements and other installations (collectively the "**Improvements**") at or above the surface of that certain lot or parcel of ground which is described on Exhibit "A" annexed hereto

DULY ENTERED
FOR TAXATION

AUG 1 2000

Robert H. Clark
Auditor Monroe County, Indiana

EXHIBIT
9

and made a part hereof, together with any and all tenements, hereditaments and appurtenances belonging to the improvements or any part thereof or in any appertaining thereto, and all rights to enforce the maintenance thereof and all other rights, liberties and privileges of whatsoever kind or character, and the reversions and remainders, income, rents, issues and Improvements or any part thereof; and together also with the right, if any, to surface support by and from the land located at or below the surface of said lot or piece of ground; and together also with the right, if any, to enter and invade the surface and subsurface of the said lot or piece of ground to maintain, repair, replace and restore the Improvements (collectively, the **"Improvement Rights"**).

TO HAVE AND TO HOLD the above described Improvements and Improvement Rights, with all the appurtenances thereunto belonging or in any way appertaining, unto the Grantee, it successors and assigns forever.

IN WITNESS WHEREOF, the Grantor has hereunto set its hand and seal, as of the 27th day of July, 2000.

Witnesses:
Barbara Howison
 Barbara Howison

GLIMCHER HOLDINGS LIMITED PARTNERSHIP, a Delaware limited partnership

Laura E. Bordeau
 Stacy Keyerleber Laura E. Bordeau

By: Glimcher Holdings, Inc.,
 General Partner

By: [Signature]
 George A. Schmidt
 Executive Vice President

STATE OF OHIO)
)
COUNTY OF FRANKLIN) SS.:

Before me, a Notary Public in and for said County and State, personally appeared George A. Schmidt, Executive Vice President of Glimcher Holdings, Inc., General Partner of Glimcher Holdings Limited Partnership, who acknowledged the execution of the foregoing Limited Warranty Deed for an on behalf of said corporation.

Joyce D. Hunter

Notary Public

My commission expires: _____



JOYCE D. HUNTER
Notary Public, State of Ohio
My Commission Expires 03-26-06

INSTRUMENT PREPARED BY:

David J. Deely, Senior Counsel
Glimcher Properties Limited Partnership
20 South Third Street
Columbus, Ohio 43215

RECORD AND RETURN TO:

David H. Kamen
Bryan Rental, Inc.
2356 Industrial Drive
Bloomington, Indiana 47404

EXHIBIT A

Legal Description of Real Property

A part of the Northeast Quarter of Section One (1), Township Eight (8) North, Range Two (2) West, Monroe County, Indiana, described as follows:

Beginning at a point of the West right of way of State Route Number 37, said point being 165.25 feet South and 13.43 feet West of the Northeast corner of the Northeast Quarter of said Section 1, thence on said right of way South 00 degrees 20 minutes 30 seconds East 804.90 feet; thence leaving said right of way North 89 degrees 27 minutes 38 seconds West 612.18 feet; thence North 00 degrees 23 minutes 08 seconds West 280.00 feet, thence North 89 degrees 27 minutes 38 seconds West 145.00 feet; thence North 00 degrees 23 minutes 08 seconds West 385.00 feet, thence North 89 degrees 27 minutes 38 seconds West 10.00 feet; thence North 00 degrees 23 minutes 08 seconds West 265.00 feet to a point on the South right of way of State Route Number 48; thence on said right of way South 89 degrees 27 minutes 38 seconds East 6.07 feet; thence continuing on said right of way South 79 degrees 51 minutes 12 seconds East 74.17 feet; thence leaving said right of way South 00 degrees 23 minutes 08 seconds East 252.62 feet; thence South 89 degrees 27 minutes 38 seconds East 335.99 feet; thence North 00 degrees 23 minutes 08 seconds West 205.35 feet to a point on the South right of way of State Route Number 48; thence on said right of way South 89 degrees 19 minutes 24 seconds East 267.02 feet; thence continuing on said right of way South 52 degrees 42 minutes 40 seconds East 108.37 feet to the point of beginning, containing 12.695 acres, more or less.

EXCEPT that portion deeded to the State of Indiana in a Quitclaim Deed recorded November 21, 1989 in Deed Record 367, Page 302, more particularly described as follows:

A part of the Northeast Quarter of Section 1, Township 8 North, Range 2 West, Monroe County, Indiana, described as follows:

Commencing at the Northeast corner of said section; thence North 89 degrees 23 minutes 24 seconds West 16.50 feet along the North line of said section to the prolonged West line of the first of two tracts of land described in Deed Record 98, Page 484; thence South 0 degrees 02 minutes 42 seconds East 160.00 feet along said West line prolonged to the Northwest corner of said tract and the point of beginning of this description, which point is where the West boundary of S.R. 37 meets the Southwestern boundary of the intersection of said S.R. 37 and S.R. 48; thence South 0 degrees 02 minutes 42 seconds East 804.90 feet along the boundary of said S.R. 37 to the Southeast corner of the owner's land; thence North 89 degrees 23 minutes 24 seconds West 48.70 feet along the South line of the owner's land; thence North 0 degrees 02 minutes 00 seconds West 449.90 feet; thence North 18 degrees 02 minutes 15 seconds

West 210.30 feet; thence South 89 degrees 58 minutes 00 seconds West 67.67 feet to the West line of the owner's land; thence North 00 degrees 25 minutes 44 seconds West 216.43 feet along said West line to the South boundary of said S.R. 48; thence South 89 degrees 22 minutes 00 seconds East 93.02 feet along the boundary of said S.R. 48 to the Southwestern boundary of the intersection of S.R. 48 and said S.R. 37; thence South 55 degrees 51 minutes 40 seconds East 108.37 feet along the boundary of the intersection of said S.R. 48 and said S.R. 37 to the point of beginning and containing 1.713 acres, more or less.

EXCEPT that portion deeded by quitclaim deed recorded October 30, 1981 in Deed Record 286, Page 180, more particularly described as follows:

A part of the Northeast quarter of Section One (1), Township Eight (8) North, Range Two (2) West, Monroe County, Indiana, described as follows:

Beginning at a point on the West right-of-way of State Route Number 37, said point being 165.25 feet South and 13.43 feet West of the Northeast corner of the Northeast quarter of said Section 1; thence along the South right-of-way of State Road 48 North 52 degrees 42 minutes 40 seconds West, 108.37 feet; thence North 89 degrees 19 minutes 24 seconds West 93.02 feet; to the point of beginning; continue thence North 89 degrees 19 minutes 24 seconds West 134.00 feet; thence South 00 degrees 23 minutes 08 seconds East 228.00 feet; thence South 89 degrees 19 minutes 24 seconds East 134.00 feet; thence North 00 degrees 23 minutes 08 seconds West 228.00 feet to the point of beginning. Containing in all 0.701 acre, more or less.

EXHIBIT B**Permitted Exceptions**

1. Real estate taxes for the year 1999 due and payable in November, 2000 and all subsequent taxes and assessments.
2. Gas Line Easement by and between Charles McGinnis, Louis B. McGinnis, Grantor, and Indiana Gas Company, Inc., and Indiana corporation, dated July 29, 1971 and recorded August 19, 1971 in Deed Record 205, Page 535 in the Office of the Recorder of Monroe County, Indiana.
3. Rights for ingress and egress and access, all as set out in that certain Corporate Warranty Deed by and between Monroe Development Corporation, an Indiana corporation, Grantor, and Rights of Farmers and Mechanics Federal Savings and Loan Association, dated October 6, 1977 and recorded October 7, 1977 in Deed Record 255, Page 78, in the Office of the Recorder of Monroe County, Indiana.
4. A 20 foot sanitary sewer easement granted by that certain Warranty Deed by and between Timothy Winger, Betty Winger, husband and wife, of Monroe County, in the State of Indiana, and Marianne W. Bungler, of Monroe County, in the State of Indiana, dated December 2, 1977 and recorded December 3, 1977 in Deed Record 256, Page 326, in the Office of the Recorder of Monroe County, Indiana.
5. Perpetual non-exclusive easement granted by that certain Easement Agreement by and between David E. Schnoor, Trustee, as Grantor to Whitehall Associates, an Indiana limited partnership, Grantee, dated August 23, 1979 and recorded August 28, 1979, in Deed Record 287, Page 83, in the Office of the Recorder of Monroe County, Indiana.
6. Water Line Easement by and between Bloomington Square Associates, Grantor, in favor of City of Bloomington, Indiana Utility Department, and their successor and assigns, Grantee, dated November 17, 1981 and recorded December 8, 1981 in Deed Record 286, Page 518, in the Office of the Recorder of Monroe County Indiana.
7. Electric Underground Line Easement by and between Bloomington Square Associates, Grantor, in favor of Public Service Company of Indiana, Inc., an Indiana corporation, and its successor and assigns, Grantee, dated November 17, 1981 and recorded December 22, 1981 in Deed Record 287, Page 83, in the Office of the Recorder of Monroe County, Indiana.

- 8. Modification of Covenants for Operation, Maintenance and Reciprocal Easements, by and between Hardee's Food Systems, Inc., Kmart Corporation, a Michigan corporation, Whitehall Associates, an Indiana limited partnership, Bank One, Bloomington, N.A., American Drugstores, Inc., an Illinois corporation, Great Western Capital Corporation, a California corporation, Bloomington Square Associates, an Indiana limited partnership, city of Bloomington, a municipal corporation and Quincy Plaza Associates, L.P., dated May 8, 1990 and recorded June 19, 1990, in Miscellaneous Record 200, Page 350, in the Office of the Recorder of Monroe County, Indiana.
- 9. Warranty Assignment and Assumption of Vendee's Interest in Installment Sale Agreement, by and between Quincy Plaza Associates, an Illinois limited partnership, Assignor, and Glimcher Holdings Limited Partnership, a Delaware limited partnership, Assignee, dated November 22, 1993 and recorded February 4, 1994 in Release and Assignment Record 122, Page 346, in the Office of the Recorder of Monroe County, Indiana.
- 10. Memorandum of Lease by and between Waldorf and Associates, a Texas limited partnership, Landlord, and Kmart Corporation, a Michigan corporation, Tenant, dated January 17, 1980a and recorded September 11, 1980 in Miscellaneous Record 117, Page 402, in the Office of the Recorder of Monroe County, Indiana.

**Indiana Gross Income Tax on
Sale of Real Estate**

Paid by Glimcher Holdings

Date Paid 8/11/2000

Amount Paid \$ 9,837.74

Treasurer's No. 418264

Monroe County