

ADDENDUM NO. 1
TO THE
DRAWINGS AND SPECIFICATIONS
FOR THE
10th Street Pedestrian Improvement Project

ISSUED FROM: The City of Bloomington
Planning and Transportation Department
Post Office Box 100
401 North Morton Street, Suite #130
Bloomington, Indiana 47402

Issue Date: November 9th, 2017

Letting Date: November 14th, 2017

This Addendum No.1 to the drawings and specifications shall supplement, amend and become a part of the bidding documents, plans, and specifications for the 10th Street Pedestrian Improvement Project. All bids and construction contracts shall be based on these modifications to the original contract documents. Bidders shall acknowledge receipt of this Addendum on the Bid Form. Failure to do so may subject the Bidder to disqualification.

Item No. 1: The Tamarron Homeowners Association (HOA) installed an irrigation system within the right-of-way. The contractor shall contact the HOA (Dave Gentry) and coordinate any possible conflicts with the system and the proposed work. It is not anticipated that any relocation work will be required. Any damage to the system will be repaired by the contractor at no cost to the City.

Item No. 2: All submitted drug testing policies must demonstrate that the policy applies to all employees, including both union and non-union employees. If some employees are subject to drug testing under a collective bargaining agreement, the bidder must submit the drug testing policy from the CBA along with their general drug testing policy.

Item No. 3: For informational purposes, an exhibit has been published that depicts the Subsurface Underground Engineering (SUE) that was used in the development of the plans.

Item No. 4: A Pre-Bid Conference was conducted on November 2nd, 2017. A copy of the agenda, along with notes from the conference, has been published and is attached to this addendum.

Item No. 5: A statement from Barbara McKinney, Director, Human Rights Commission, in regards to the affirmative action plan submittal requirements, has been published and is attached to this addendum.

Item No. 6: Signs 1, 2, and 3 on drawing sheet 12 of 18 shall be florescent yellow green in accordance with MUTCD Section 7B.07 – Sign Color for School Warning Signs Standard. This includes the "SCHOOL" portion of the speed limit sign shown on drawing sheet 11 of 18.

Item No. 7: Questions and Answers

- (Q) What is the completion date for the project?
- (A) The Contractor will have 90 calendar days from the Notice-to-Proceed (NTP) to complete the project. A NTP will be issued shortly after the execution of the contract. Due to winter weather, no days will be charged between December 1st and March 31st. Calendar days will resume to be charged on April 1st, 2018, and the anticipated completion date is June 30th, 2018.
- (Q) If rock is encountered how will excavation be paid for?
- (A) It is anticipated that an unknown quantity rock will need to be removed for the installation of the storm sewer. The contractor shall include the removal of 150 CYDs of rock in the lump sum bid. Any rock amount removed above 150 CYDs will be paid via a change order at a cost of \$62.18/CYD. In the event that less than 100 CYDs of rock is removed, there will be a deduct from the contract price of \$62.18/CYD for each cubic yard of rock below 100 CYDs that was not removed. Rock removal quantities are to be measured daily and verified by the City in order to be considered for payment.
- (Q) Can the 2' area in front of all the curbs be concrete equivalent to the asphalt thickness plus 1 1.2" HMA surface over the concrete? This should be a cost savings and would allow contractor to get this area filled back in quicker.
- (A) The 2 foot area in front of all curbs shall be 9-inch PCCP for patching with a 1.5 IN. HMA overlay. Compacted stone shall be used as needed to adjust grade.
- (Q) Will all disturbed areas require sod or just the area indicated on plans?
- (A) No sodding is required on this project. Seed and mulch shall be used for all disturbed areas. Seed shall be seed mixture type U-modified, and contain 100% turf-type tall fescue comprised of 3 elite, blue tag certified, rhizomatous type seeds placed with an application rate of 10 LBS per 1000 SFT.
- (Q) Are there details about the HAWK signal?
- (A) No. The HAWK (PHB) will be installed by others.
- (Q) Are there boring logs, will there be an allotment for rock excavation?
- (A) No geotechnical borings were completed. Item No. 3 covers the amount of sub-surface investigation that was completed for the design. Rock excavation will be paid as described above.
- (Q) The storm trench in the road does not have a detail for the repair, will this require a 9 in. concrete patch?
- (A) The trench shall be filled with flowable fill, capped with a 9 inch PCCP for Patching cap, and 1.5-inch HMA overlay. The City standard detail for patching shall be used and is attached to this addendum.
- (Q) There is an existing storm pipe that crosses E. Deckard Drive and the utility entrance, will that pipe need to be removed?
- (A) There are two separate existing CMP storm pipes; one crossing E. Deckard Drive and one crossing the utility entrance. Both pipes shall be removed. Once the pipe under E. Deckard Drive is removed, the trench shall be filled with flowable fill, capped with a 9-inch PCCP for Patching cap, and 1.5-inch HMA overlay.
- (Q) Does the curb require stone under it?
- (A) Yes, per INDOT standard detail.

- (Q) Usually INDOT has 6" of stone under HMA for Approaches. The plans do not show stone. Can you please clarify?
- (A) Yes, 6" stone is required under the HMA for Approaches per INDOT standard details.
- (Q) Do you want stone under the HMA patch?
- (A) Stone is not required between the flowable fill and PCCP for Patching cap.
- (Q) Will Deckerd Road be able to be closed to install storm sewer across the intersection?
- (A) Temporary closures of East Deckard Drive will be permitted during working hours in order to facilitate construction across the roadway. The roadway must be re-opened at the end of each day. Road closures must be in compliance with current MUTCD, INDOT and City standards. Contractor will be responsible for coordinating these closures with the City's Project Manager and notifying the neighborhood in advance of any closures.

	<p>CERTIFIED BY: <u> 11/9/2017</u></p> <p>ANDREW CIBOR TRANSPORTATION & TRAFFIC ENGINEER CITY OF BLOOMINGTON, IN</p>
--	---

Acknowledge receipt of the addendum by representing it on the Bid form in Section B and submitting a signed copy with your bid proposal.

RECEIVED BY: CONTRACTOR (FIRM AND ADDRESS)

SIGNATURE: _____

DATE: _____

PRINTED NAME: _____

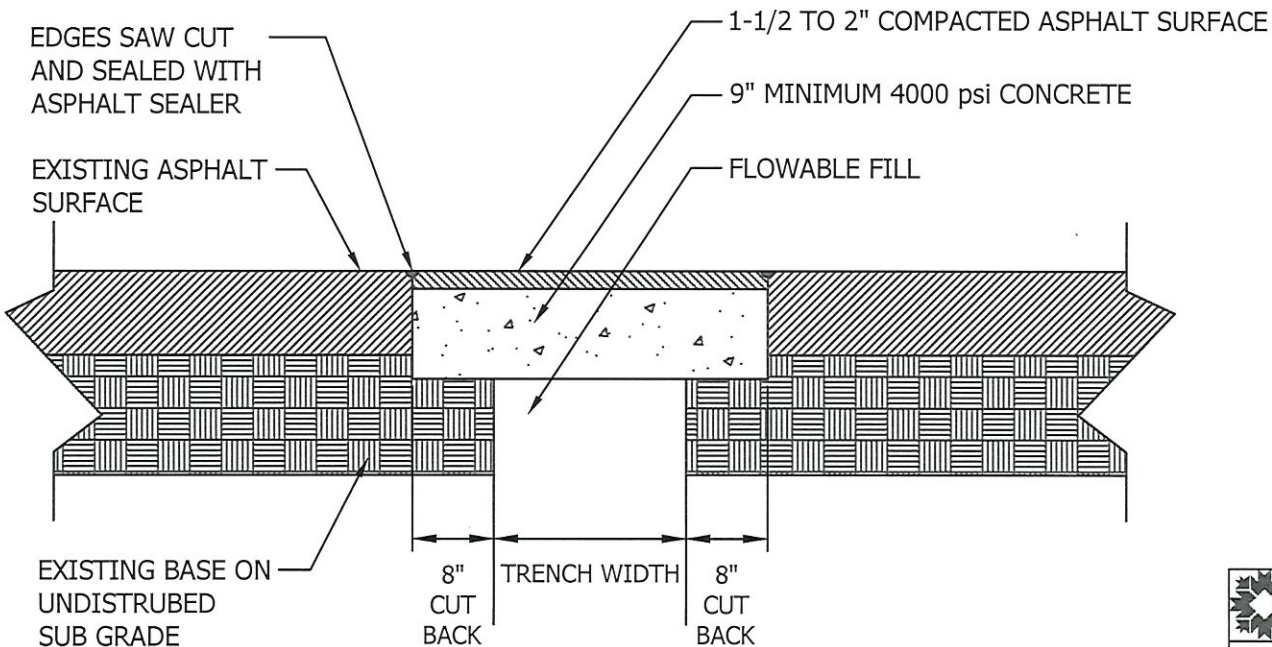

TITLE: _____



ASPHALT SURFACE STREET CUT REPAIR

NOTES:

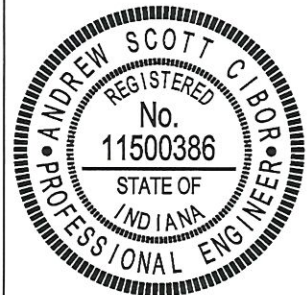
1. A SURFACE PATCH SHALL BE EXTENDED TO ADJACENT SEAM IF ANOTHER SEAM IS WITHIN 2' OF PATCH AREA.
2. CONTACT STREET DEPARTMENT (812-349-3448) IF USING PLATE DURING WINTER.
3. CONTRACTOR SHALL FOLLOW ALL MUTCD GUIDELINES.
4. ALLOW ADEQUATE CURE TIME BEFORE PERMITTING TRAFFIC ON CONCRETE.
5. ALLOW ADEQUATE CURE TIME BEFORE PLACING COMPACTED ASPHALT SURFACE ON CONCRETE.

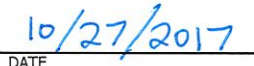
	CITY OF BLOOMINGTON
STANDARD ROADWAY STREET CUT REPAIR DETAILS	
STANDARD DRAWING SC-2	
	 ENGINEER  DATE



10th Street Pedestrian Improvements Project

Pre-Bid Conference November 2nd, 2017

1. Introduction
 - a. Coordination
 - i. INDOT
 - ii. MCCSC
 - iii. Community
 - b. Project overview
2. Affirmative Action Plan Requirements ([Statement from Barbara McKinney](#))
3. Schedule
 - a. Addendum will be posted next week.
 - b. Bids are due November 14th, 2017 at or before 4:30 PM
 - i. Bids will be opened at the 5:30PM Board of Public Works Meeting
 - c. Award, November 28th, 2017 Board of Public Works Meeting.
 - d. NTP
 - e. Construction
4. Bid requirements
 - a. Affirmative action plan on file.
 - b. Questionnaire Form 96, Parts I through IV
 - c. Bid Guarantee (5% of total bid amount)
 - d. Trench Safety Systems Affidavit
 - i. Located at the end of the sample agreement.
 - ii. Remember to include the cost of the trench system on the bid sheet.
 - e. Drug Testing Program Affidavit
 - i. Required at time of bidding for bids over \$150,000
 - ii. Located at the end of the sample agreement.
 - f. Performance bond
 - i. Required prior to award of the contract.
 - g. Payment bond
 - i. Required prior to the award of the contract.
 - h. Escrow agreement (Prior to NTP)
 - i. E-Verify
 - j. Non-collusion Affidavit
 - k. City Approved Vendor (Prior to award)
 - l. Certificate of Insurance (Prior to NTP)
5. MOT
 - a. INDOT controlled roadway.
 - b. Two phases as depicted in the plans.
6. Utilities
 - a. One relocation that is currently underway. Street light pole is being relocated.



- b. Multiple utilities in the construction limits.
7. Special Provisions
 - a. Review prior to submitting bid.
 - b. Sidewalks constructed to INDOT Standards, with the exception of 4" compacted aggregate, NO. 53, as shown on the typical sections.
8. Material Testing and Submittals
9. Invoicing
 - a. Lump sum, no escrow
 - b. Progressive, need escrow agreement
10. Trench Safety
 - a. Attachment 'B' at the end of the bidding documents
 - b. OSHA trench safety standard, 29 C.F.R 1926, Subpart P.
 - c. Include the cost of the trench system in bid.
 - d. Show the cost of the system on the bid sheet and Attachment 'B'.
11. Drug Testing Program
 - a. Attachment 'D' at the end of the bidding documents
 - b. Submitted plan in accordance with IC 4-13-18.
12. Questions
 - i. (Q) Can you please let me know a construction schedule so we can gauge our interest and ability to bid this job?
 - (A) Both this project and the Rockport Road project is expected to winter-out (Dec thru March). The City's goal is to get both awarded this year and the funds secured. We will also work with the contractor on the notice-to-proceed so that they can begin, if they choose, this winter. However, it is anticipated that construction will begin on or about April 1st, 2018.
 - ii. (Q) Can the 2' area in front of all the curbs be concrete equivalent to the asphalt thickness plus 1 1/2" HMA surface over the concrete? This should be a cost savings and would allow contractor to get this area filled back in quicker.
 - (A) See Addendum.

(Q) Will all disturbed areas require sod or just the area indicated on plans?

(A) Sod is not required, (see addendum)

(Q) Are there details about the HAWK signal?

(A) The HAWK (PHB) will be installed by others as part of another project.

(Q) Are there boring logs, will there be an allotment for rock excavation?

(A) See Addendum.

(Q) The storm trench in the road does not have a detail for the repair, will this require a 9 in. concrete patch?

(A) The standard City patch details will be provided. See Addendum.



**City of Bloomington
Planning and Transportation Department
Engineering Division**

(Q) There is existing storm pipe that crosses E Deckard Drive and the utility entrance, will that pipe need to be removed?

(A) [Yes, they must be removed. See Addendum.](#)

(Q) Does the curb require stone under it?

(A) [Yes, curb has 6" of compacted 53'2 under it. See Addendum.](#)

(Q) Usually INDOT has 6" of stone under HMA for Approaches. The plans do not show stone. Can you please clarify?

(A) [Yes, approaches must have stone under HMA. See Addendum.](#)

(Q) Do you want stone under the HMA patch?

(A) [See Addendum.](#)

13. Conclusion

Pre-bid meeting for 10th street pedestrian improvements
Hooker 11/2/17

To be eligible to bid, every bidder has to have an affirmative action plan on file with city legal at least 24 hours before the bid, or by 11/13.

This plan has to include all of the protected classifications required by the City, has to have a non-retaliation statement, has to include a workforce breakdown that is not more than six months old, etc.

If your company has submitted an affirmative action plan to the city before, they should still have it on file, but it may well need to be updated to comply with new rules. It is your responsibility to touch base with the contract compliance officer (Barbara McKinney, 349-3429, mckinneb@bloomington.in.gov) so she can let you know the City has your plan on file and if it does, if your plan needs to be updated. This has to be done by 11/13.

If your company does not have an affirmative action plan, you can use the model affirmative action plan included in your packet. You will need to fill in the blanks on the plan, complete the workforce breakdown, get appropriate signatures and get that to Barbara by 11/13.

If your company has an affirmative action plan that it created on its own, again, you need to get that to Barbara so she can make sure it meets the City requirements. We ask that you do that as soon as possible so there's time to make any changes, if necessary.

Any questions, please call Barbara.



10th Street Pedestrian Improvements Project

Pre-Bid Meeting

At City Hall – 401 North Morton Street
 Thursday, November 2nd, 2017
 Hooker Conference Room
 10 AM

Name:	Company:	Phone:	Email Address:
1. Jane Fleig	CBU	812 349 3631	fleigj@bloomington.in.gov
2. Brent Foster	Milestone	[REDACTED]	[REDACTED]
3. Garnett Gough	E+B		
4. KEITH SPENNER	E&B PAVING		
5. Richard Groomer	Groomer const.		
6. Ralph Groomer	Groomer const		
7. Andrew Cibur	City P&T		
8. Neil Kopper	City P&T	812-349-3423	koppern@bloomington.in.gov
9. Jackie Moore	City Legal	812 349-3551	moorej@bloomington.in.gov
10. Russell White	City P&T	812-349-3525	whiter@bloomington.in.gov
11. Renee Goff	Shrewsbury	317-841-4799	rgoff@shrewsusa.com
12.			
13.			
14.			
15.			
16.			
17.			
18.			
19.			
20.			